



INTERNATIONAL DICTIONARY OF

# PSYCHOANALYSIS

PSYCHOANALYSIS



ALAIN de MIJOLLA  
Editor in Chief

# **INTERNATIONAL DICTIONARY OF PSYCHOANALYSIS**

**DICTIONNAIRE INTERNATIONAL DE LA PSYCHANALYSE**

# EDITORIAL BOARD AND TRANSLATORS

## EDITORIAL BOARD AND TRANSLATORS

### EDITOR IN CHIEF

Alain de Mijolla

*President and founder of the International Association for the History of Psychoanalysis*

*Neuropsychiatrist and psychoanalyst*

*Member of the Société psychanalytique de Paris (Paris Psychoanalytic Society)*

*Member of the International Psychoanalytic Association (IPA)*

*Member of the Conceptual and Empirical Research Committee of the IPA*

### EDITORIAL BOARD (French Edition)

Sophie de Mijolla-Mellor

*Psychoanalyst and professor of psychopathology and psychoanalysis*

*University of Paris VII, Denis-Diderot*

*Member of the Quatrième groupe (O.P.L.F.)*

Roger Perron

*Director of Honors Research at National Center for Scientific Research, Paris*

*Member of the International Psychoanalytic Association (IPA)*

Bernard Golse, MD

*Pediatric psychiatrist and psychoanalyst*

*Chief of staff of Pediatric psychiatry, Saint-Vincent de Paul Hospital, Paris*

*Professor of Child and Adolescent Psychiatry*

*University of Paris V, René Descartes*

### U.S. ADVISORY BOARD

Edward Nersessian, MD

*Training and Supervising Analyst*

*New York Psychoanalytic Institute*

*Clinical Associate Professor of Psychiatry*

*New York Hospital-Cornell Medical Center*

Paul Roazen, Ph.D.

*Professor Emeritus, Social and Political Science*

*York University*

### BOARD OF TRANSLATORS

Philip Beitchman

Jocelyne Barque

Robert Bononno

Andrew Brown

Dan Collins

Liam Gavin

John Galbraith Simmons

Sophie Leighton

Donald Nicholson-Smith

Scott Savaiano

Paul Sutton

Gwendolyn Wells

# **INTERNATIONAL DICTIONARY OF PSYCHOANALYSIS**

**DICIONNAIRE INTERNATIONAL DE LA PSYCHANALYSE**

**VOLUME ONE**

**A–F**

**ALAIN DE MIJOLLA**

**EDITOR IN CHIEF**

**MACMILLAN REFERENCE USA**

*An imprint of Thomson Gale, a part of The Thomson Corporation*

**THOMSON**  
—★—™  
**GALE**



# **INTERNATIONAL DICTIONARY OF PSYCHOANALYSIS**

**DICIONNAIRE INTERNATIONAL DE LA PSYCHANALYSE**

**VOLUME TWO**

**G-PR**

**ALAIN DE MIJOLLA**

**EDITOR IN CHIEF**

**MACMILLAN REFERENCE USA**

*An imprint of Thomson Gale, a part of The Thomson Corporation*

**THOMSON**  
—\*—™  
**GALE**

# **INTERNATIONAL DICTIONARY OF PSYCHOANALYSIS**

**DICIONNAIRE INTERNATIONAL DE LA PSYCHANALYSE**

**VOLUME THREE**

**PS-Z**

**ALAIN DE MIJOLLA**

**EDITOR IN CHIEF**

**MACMILLAN REFERENCE USA**

*An imprint of Thomson Gale, a part of The Thomson Corporation*

**THOMSON**  
—★—™  
**GALE**



INTERNATIONAL DICTIONARY OF PSYCHOANALYSIS  
DICTIONNAIRE INTERNATIONAL DE LA PSYCHANALYSE

Editor in Chief  
Alain de Mijolla

©2005 Thomson Gale, a part of the Thomson Corporation.

Thomson Star Logo and Macmillan Reference USA are trademarks and Gale is a registered trademark used herein under license.

Originally published as  
*Dictionnaire international de la psychanalyse*  
© 2002, Editions Calmann-Lévy

*This book was published with the support of the French Ministry of Culture—National Book Center. Cet ouvrage a été publié avec l'assistance du Ministère chargé de la culture—Centre National du Livre.*

**ALL RIGHTS RESERVED**

No part of this work covered by the copyright hereon may be reproduced or used in any form or by any means—graphic, electronic, or mechanical, including photocopying, recording, taping, Web distribution, or information storage retrieval systems—without the written permission of the publisher.

*For more information, contact*  
Macmillan Reference USA  
An imprint of the Gale Group  
27500 Drake Road  
Farmington Hills, MI 48331-3535  
Or you can visit our Internet site at  
<http://www.gale.com>

For permission to use material from this product, submit your request via Web at <http://www.gale-edit.com/permissions>, or you may download our Permissions Request form and submit your request by fax or mail to:  
*Permissions Department*  
Thomson Gale  
27500 Drake Road  
Farmington Hills, MI 48331-3535  
Permissions Hotline:  
248-699-8006 or 800-877-4253 ext. 8006  
Fax: 248-699-8074 or 800-762-4058

Cover photographs reproduced by permission of The ArtArchive/Dagli Orti (A) and C. Herscovivi, Brussels/Artists Rights Society ("La Traverse difficile" by René Magritte), and Hulton-Deutsch Collection/Corbis (City of Vienna and Oedipus statue).

While every effort has been made to ensure the reliability of the information presented in this publication, Thomson Gale does not guarantee the accuracy of the data contained herein. Thomson Gale accepts no payment for listing; and inclusion in the publication of any organization, agency, institution, publication, service, or individual does not imply endorsement of the editors or publisher. Errors brought to the attention of the publisher and verified to the satisfaction of the publisher will be corrected in future editions.

**LIBRARY OF CONGRESS CATALOGING-IN-PUBLICATION DATA**

Dictionnaire international de la psychanalyse. English.  
International dictionary of psychoanalysis = Dictionnaire international de la psychanalyse / Alain de Mijolla, editor in chief.  
p. ; cm.  
Enhanced version of the 2002 French edition.  
Includes bibliographical references and index.  
ISBN 0-02-865924-4 (set hardcover : alk. paper) -- ISBN 0-02-865925-2 (v. 1) -- ISBN 0-02-865926-0 (v. 2) -- ISBN 0-02-865927-9 (v. 3)  
1. Psychoanalysis--Encyclopedias. I. Mijolla, A. de. II. Title. III. Title: Dictionnaire international de la psychanalyse.  
[DNLM: 1. Psychoanalysis--Encyclopedias--English. WM 13 D5555 2005a]  
RC501.4.D4313 2005  
616.89'17'03--dc22

2005014307

This title is also available as an e-book  
ISBN 0-02-865994-5 (set)  
Contact your Thomson Gale sales representative for ordering information.

Printed in the United States of America  
10 9 8 7 6 5 4 3 2 1

# CONTENTS

## CONTENTS

Preface to the French Edition . . . . .	vii
Preface to the American Edition . . . . .	xv
Introduction to the American Edition . . . . .	xix
List of Entries . . . . .	xxiii
Directory of Contributors . . . . .	lv
Thematic Outline . . . . .	lxix
Chronology . . . . .	lxxxv

### INTERNATIONAL DICTIONARY OF PSYCHOANALYSIS

A–B . . . . .	1
Photograph Insert . . . . .	following p. 238
C–F . . . . .	239
G–L . . . . .	663
Photograph Insert . . . . .	following p. 998
M–Pr . . . . .	999
Ps–S . . . . .	1345
Photograph Insert . . . . .	following p. 1722
T–Z . . . . .	1723
Freudian Bibliography . . . . .	1893
General Bibliography . . . . .	1903
Translation of Concepts/Notions . . . . .	2013
Acknowledgements . . . . .	2045
Index . . . . .	2049

# EDITORIAL AND PRODUCTION STAFF

## EDITORIAL AND PRODUCTION STAFF

Frank Menchaca  
*Publisher*

Nathalie Duval  
*Acquisitions and Development Editor*

Rachel J. Kain  
*Project Editor*

Patricia Kamoun-Bergwerk, Pamela A. Dear, and Nancy Matuszak  
*Editorial Support*

David Gassaway, Samera Nasereddin, Alan Thwaites, Shauna Toh, and John Yohalem  
*Copyeditors*

Eleanor Stanford and Shanna Weagle  
*Proofreaders*

Matthew von Unwerth and Clayton Simmons  
*Bibliographic Researchers*

Do Mi Stauber  
*Indexer*

Luann Brennan  
*Editorial Systems Implementation Specialist*

Lezlie Light  
*Imaging Coordinator*

Denay Wilding  
*Editor, Imaging and Multimedia Content*

Margaret Abendroth and Ron Montgomery  
*Rights Acquisition Management*

Jennifer Wahi  
*Art Director*

Evi Seoud  
*Assistant Manager, Composition*

Wendy Blurton  
*Senior Manufacturing Specialist*

# PREFACE TO THE FRENCH EDITION

## PREFACE TO THE FRENCH EDITION

*This preface outlines the history and options of an editorial undertaking which, since it took shape gradually over a ten-year period, could naturally not be brought up to date in every detail. I hope that what follows will answer most of the questions of readers taken aback by such and such an omission or such and such an editorial decision. My most important concern, however, is that these remarks should help elicit the indispensable additions and corrections that it is to be hoped will be submitted as time goes on.*

To participate in the step-by-step construction of an international dictionary of psychoanalysis is a strange adventure, marked not only by enthusiasm but also from time to time by disillusion. The process might well be compared to the education of children, a realistic view of which (sometimes attributed to Freud) asserts that one may be almost certain that one's hopes will not be fully realized. All the same, the years I spent with the editorial board assigning and patiently gathering in the more than fifteen hundred articles comprising this work, and the subsequent years preparing all this material for publication, have been among the most exciting I have known. One reason was the variety and cordiality of the international connections that the project created; another was the growing awareness of the vigorous multifacetedness of psychoanalysis as a whole, which has been evolving for over a century now within so many different nations, languages and cultures.

The charge of dogmatism, too often leveled at psychoanalysis, simply evaporates in face of the heterogeneity apparent to anyone who explores the many ways in which psychoanalytic theory and practice are understood and experienced around the world. Freud's metapsychological concepts, which he called "*Grundbegriffe*"—a set of foundations few in number but solidly anchored—have constantly demonstrated their usefulness, and they have endured almost unchanged. On the other hand, most Freudian, post-Freudian or even para-Freudian notions are like so many living organisms—ever prone to modification, and tending to be forgotten and (sometimes) resurrected; above all, they are subject to divergent interpretations, reflecting the element of the unforeseeable that is inevitably present for any analyst who refuses to be tied down by rigid theoretical models. Such divergences result too from the lessons of clinical practice and the temporary or permanent changes which that experience imposes on analytic theory; they are the traces of an empirical inquiry that has continued unabated from Freud's earliest tentative explorations to the confrontation with life as it is lived today. The coexistence in this dictionary of ideas that are oftentimes in contradiction with one another, or that have been developed in different ways from one continent to another, is testimony to their main characteristic: they are provisional conceptual tools, and their ephemeral quality indicates that in psychoanalysis, in one sense at least, everything always remains to be discovered, for the questions asked are forever being posed anew.

Once the idea of this dictionary had been conceived, based on the principle of a diversity of viewpoints, I proposed to the publishers, Calmann-Lévy, that an editorial board be formed, to be made up of recognized colleagues belonging to French psychoanalytic schools of differing orientations. I owe a great debt of gratitude to the friends who constituted that small group: Professors Sophie de Mijolla-Mellor, Roger Perron, and Bernard Golse, joined during the first stages by Dr. Jacques Angelergues. They all made vital contributions during those crucial early days. It is in their name, moreover, that I shall now describe our work methods and the route we took.

At a very early stage, thanks to a letter announcing our plan, we won the allegiance of a number of distinguished psychoanalysts. They became a kind of support committee, and their prestige lent weight to our approach to potential contributors. Simultaneously, we solicited the participation and counsel of not a few researchers known to us from our years as practitioners of psychoanalysis; we were also able to draw on connections built up over the fifteen-year existence of the International Association for the History of Psychoanalysis (IAHP). In this way a group of “advisors” was assembled, each of whom was asked to assume responsibility for a particular segment of our vast field of operations, to suggest to the editorial committee those concepts or individuals that they felt should absolutely be included as entries in the panoramic vision of the dictionary, and to identify the authors who in their view would be the best fitted to write those articles. Their advice was gratefully received and closely followed.

At the same time, we consulted a good number of indexes of existing psychoanalytic works in order to reach a first list of concepts; and the IAHP’s *Revue Internationale d’histoire de la psychanalyse* (International Review of the History of Psychoanalysis; discontinued in 1992) was a good source in determining which figures or events were the most frequently cited. In 1995 and 1996, at our editorial committee meetings, we debated all the proposed topics thus accumulated, rejecting some and adding others, until we arrived at a list that, truth to tell, was never completely finalized until the very last days before the manuscript was delivered. Our choices were made in a collegial spirit, before each of us was put in charge of a variable number of entries to assign to their respective authors along with general composition and format guidelines intended to impose some measure of uniformity on the immensely varied material to be produced.

Since almost a third of the entries commissioned were written in languages other than French, our commitment to an international approach was indeed undeviating, but there is no denying that this dictionary was conceived and realized by psychoanalysts trained and practicing in France. The selection of topics and the content of the entries may well reveal a somewhat “French” cast of mind. How indeed could it be otherwise? But it is my sincere hope that foreign readers will adopt an actively critical attitude in this connection, by suggesting, even contributing, additions. Nothing could be more in tune with our desire for the widest possible opening onto the world at large.

On the other hand, of course, by opting for a great diversity of contributors we risked losing a sense of unity, and unity is reassuring. We were quite aware that alert critics were bound to underscore the lacunae, the inadequacies, even the outright contradictions that would appear among entries written, say, by a French author, an English or American analyst, and a colleague from South America—each loyal, moreover, to a particular theoretical orientation. Similarly, the very topics chosen by our advisors must perforce reflect their personal judgments rather than ours. Occasionally we editors proposed additional subjects, but by and large we allowed the advisors’ selection to stand, out of respect for the agreement we had with them; in any event, it would have ill behooved the editorial board or the editor-in-chief to claim a knowledge superior to that of the advisors whom we had chosen as our guides in the matter.

It should be noted that despite our request that authors abide by specified space limitations, some were so carried away by their attachment to their assigned topic that they turned in longer contributions than anticipated. In some cases we were obliged to ask for significant cuts, and I should like to thank all contributors concerned for their good-natured and prompt acquiescence to what were surely painful self-amputations. As for those who found it easier to abide by our space constraints, their contributions were retained unmodified, at the risk of giving readers the mistaken impression, in view of disparities of length, that we meant either to downplay or to highlight some particular concept or individual.

Such editorial changes to submitted manuscript as we made were minor, concerned chiefly with formal aspects (style, ordering of paragraphs, standardization of references, etc.). In no case was any kind of censorship exercised by me or by any member of the editorial board, and no important revision was made without first suggesting it to the author concerned. It was out of the question that any article be published in seriously modified form without the writer's full approval. All articles are signed, and while the editors are responsible for their publication in the context of this dictionary, they belong in the moral and literary senses to their individual authors. With this in mind, each contributor had a contract and was remunerated appropriately, the main purpose being to acknowledge his or her authorship and to keep our collaboration, friendships notwithstanding, within a clearly legal framework.

Let me reiterate, as a last point, that this dictionary was created over a period of years. As with all such enterprises, and especially one involving so many contributors sprinkled across the globe, it was bound to be overtaken here and there by events, with no realistic prospect of a complete updating prior to publication. We must hope that such time-related shortcomings will be rectified as future editions appear.

Why is a dictionary of psychoanalysis needed? Interestingly, it was rather late on in the history of psychoanalysis that the call for a clearer definition of Freudian terms, whose precision was threatened by their wider and wider currency, was first heard. The teaching offered before the Second World War at the Berlin and later at the Vienna Institute of Psychoanalysis certainly helped show up the need for analysts in training to have to hand a work that, though not a manual, would furnish precise information on a still vigorously evolving body of theory. The fact that Freud lent his support to the idea, coupled no doubt with the anxiety aroused by the defections and misapplications then plaguing the young discipline of psychoanalysis, provided added impetus.

Thanks to Richard F. Sterba's *Reminiscences of a Viennese Psychoanalyst* (Detroit: Wayne State U. P., 1982), we are acquainted with the circumstances under which the first tentative attempt to compile a dictionary of psychoanalysis was made:

In 1931, at the suggestion of A. J. Storfer, I had undertaken the task of writing a psychoanalytic dictionary (*Handwörterbuch der Psychoanalyse*). Storfer actually began this work with the definition of a few terms beginning with the letter A, but he found the task too time consuming. He asked me to continue the work with him, to which I agreed. It was a project for which my experience in 1925 and 1926, working on the index of the *Gesammelte Schriften von Sigmund Freud* (Collected Works of Sigmund Freud) was an enormous help. Soon, however, Storfer lost interest in or courage for the enormous project and dropped out of our partnership. As ransom for dissolving the partnership, he gave me the index galleys and typescript pages and all of the eleven volumes of the *Gesamtausgabe*. I carried on the work alone. The dictionary was supposed to appear gradually in sixteen issues, of which the first was published on the occasion of Freud's eightieth birthday, 6 May 1936.

The preface to the first issue was the facsimile of a letter Freud wrote to me. When I had finished the letter A of the dictionary, I had given a copy to Anna Freud and asked her to submit it for Freud's scrutiny. After a short while I received this letter from Freud, which I quote here in English translation: "Your 'dictionary' gives me the impression of being a valuable aid to learners and of being a fine



achievement on its own account. The precision and correctness of the individual entries is in fact of commendable excellence. English and French translations of the headings are not indispensable but would add further to the value of the work. I do not overlook the fact that the path from the letter A to the end of the alphabet is a very long one, and that to follow it would mean an enormous burden of work for you. So do not do it unless you feel an internal obligation—only obey a compulsion of that kind and certainly not any external pressure” (pp. 99–100; Freud’s letter translated by James Strachey, *Standard Edition*, Vol. 22, p. 253).

In the wake of this first effort, and very soon in the case of North America, there appeared several dictionaries, or lexicons presenting select passages from Freud’s writings, designed to help define psychoanalytic concepts for analysts in training in the institutes; some went further, offering explanations meant to make psychoanalytic theory more accessible to the general reader. Important works falling under this general rubric are the *Glossary of Psycho-Analytical Terms* published under the editorship of Ernest Jones in 1924, a harbinger of the *Standard Edition*; the lists generated by the *French Commission Linguistique pour le Vocabulaire Pschanalytique* in 1923–24; or the *New German-English Psycho-Analytical Vocabulary* of 1943. It is also well worth citing the *Encyclopedia of Psychoanalysis* edited by Ludwig Eidelberg (New York: Free Press, 1968) and Charles Rycroft’s idiosyncratic *Critical Dictionary of Psychoanalysis* (London: Nelson, 1968).

In France, the initiatives of Daniel Lagache began as early as the 1950s, with the start of a dictionary in installments published in Maryse Choisy’s journal *Psyché*, and they culminated in that matchless work tool, the *Vocabulaire de la psychanalyse*, by Jean Laplanche and Jean-Bertrand Pontalis (Paris: PUF, 1967; translated as *The Language of Psycho-Analysis*, London: Institute of Psycho-Analysis/Hogarth, 1973). It should be borne in mind, however, that Laplanche and Pontalis’s in-depth study was restricted for the most part to the concepts of psychoanalysis as developed in Freud’s work alone.

Later French dictionaries of psychoanalysis were also intentionally circumscribed in one way or another. Pierre Fédida’s *Dictionnaire abrégé, comparatif et critique des notions principales de la psychanalyse* (Paris: Larousse, 1974) is a case in point. Some works pointed up the theoretical contributions of Jacques Lacan, such as the *Dictionnaire de la psychanalyse* edited by Roland Chemama and Bernard Vandermersche (Paris: Larousse, 1993; expanded edition, 1998), or Pierre Kaufmann’s *L’Apport freudien* (The Freudian Contribution). Kaufmann’s book (Paris: Bordas, 1993) is presented as a psychoanalytic encyclopedia rather than a dictionary, which would presumably be more condensed. In fact, despite the inclusion of a few biographical sketches, very brief, and limited to the main figures in the history of psychoanalysis, the work does not display the diversity and world-wide scope what we have pursued in our own dictionary. Nor does it deal with the principal concepts developed on the basis of practices derived from or collateral to psychoanalysis, such as those of Jungian analytical psychology.

Outside France, noteworthy titles—among many others which we have made no attempt to inventory here—include *A Dictionary of Kleinian Thought* by Robert K. Hinshelwood (London: Free Association Books, 1989), the *Bibliographisches Lexicon der Psychoanalyse* of Elke Mühlleitner (Tübingen: Diskord, 1992), and Dylan Evans’s *Introductory Dictionary of Lacanian Psychoanalysis* (London: Routledge, 1996), the first restricted to Kleinians, the second to members of the Vienna Society between 1902 and 1938, and the third to the thought of Jacques Lacan. More recently, in the United States, Burness E. Moore and Bernard D. Fine have edited *Psychoanalysis: The Major Concepts* (New Haven: Yale University Press, 1995), which elaborates in a distinctly encyclopedic manner on some forty major psychoanalytic themes.

The present dictionary differs markedly in fact from all its predecessors in the field, including Elizabeth Roudinesco and Michel Plon’s *Dictionnaire de la psychanalyse* (Paris:

Fayard, 1997) or the collected psychoanalytic articles of the French *Encyclopaedia Universalis* (1997).

It is the only work that presents not just some nine hundred concepts or ideas, but also three hundred and sixty biographies of eminent psychoanalysts from around the world, one hundred and seventy of their most noted works, and fifty countries where psychoanalysis has taken root; more than a hundred entries deal with events that have punctuated the history of psychoanalysis in its multifarious lines of development; the institutions that have embodied that development are likewise described in detail, as are the contributions of movements, such as analytical psychology and individual psychology, which stemmed from psychoanalysis.

A chronological approach was a guiding principle, and even if it could not be followed in every single entry, our contributors were urged to hew fast to a historical perspective. Only thus can theoretical choices be relativized so that they lose their rigidly fixed character and reveal themselves to be variable according to time and place. By offering a dais to a large number of psychoanalysts of different theoretical and practical persuasions, moreover, we hoped to arrive at a kind of overall picture that was contradictory precisely because it was alive—a candid shot, as it were, of psychoanalysis today, complete with the more or less conflict-prone schools in the context of which it has developed up to now and, it is to be hoped, will continue to evolve in the future. Our intention was to distinguish our dictionary as clearly as possible from works written by a small number of collaborators expressing the point of view of a particular psychoanalytic group or tendency.

All the same, it must be understood that we believe unequivocally that psychoanalysis was conceived and has developed in the context of Freudian ideas. The reference to Freud is cardinal in this work, and other theoretical and practical options have a place here only insofar as they have a direct or indirect, temporary or permanent connection with Freud, with Freud's history, or with the history of the psychoanalytic movement that Freud founded.

Psychoanalysis was created as the twentieth century opened, and it developed along with that century, affecting its historical, cultural and moral character by reason of the new way of thinking it represented. The reader should not therefore be surprised to find entries here whose subjects are writers, philosophers—even a literary movement like Surrealism, or such events as the First and Second World Wars. But in such cases we chose not to offer a detailed and biographical or historical account, or a complete account of an individual's work, but rather to confine ourselves to the subject's relationship to psychoanalysis. This also makes it possible, however, to trace the ways in which the sound and fury of the world reverberated within psychoanalysis, causing it to change or readapt. It should be remembered, too, that if psychoanalysis has a closer intimacy with the individual's psychic suffering than do other approaches, this is attributable to the intense personal involvement of those who helped refine its powers; for this reason we paid particular attention to the biography of the pioneers and their chief successors. Readers who find certain biographical details merely anecdotal are urged to bear in mind that no theoretical proposition should be entirely detached from the conscious and unconscious life of its originator, and this goes for Freud as much as for anyone else. We have nevertheless refrained from any hasty or "wild" interpretations of individual figures: nothing could be more radically at odds with the psychoanalytic approach than to pass judgment on a human being in just a few lines.

It was indeed never the mission of this dictionary to rank individuals or tendencies. Of course, it is impossible to avoid assuming criteria of worth, but even these cannot claim to exist *sub specie aeternitatis*; rather, they are mainly reflections—setting aside the enthusiasm of a particular author for his or her subject—of the spirit of the times or of geogra-

phical context. The articles concerned with Jung or Jungian notions were thus assigned to colleagues belonging to the societies of analytical psychology. Matters Adlerian were handled likewise. And topics relating to a Sándor Ferenczi, Melanie Klein, Jacques Lacan or Françoise Dolto were entrusted to writers close to them and their ideas. All is not told—and gossip hounds are likely to be disappointed. In our view, a dictionary such as this is neither holy writ nor pamphlet, but a kind of mirror held up to the time of its writing, bearing all the signs of that time's fashions and conformities, and addressed to future generations, who with the benefit of hindsight will assuredly be able to read far more between the lines than is discernible to us.

With respect to our handling of Freud's works, we decided that the best way to avoid entanglement in the thickets of editions and translations around the world was to adopt as our basic system of reference the chronological bibliographical tags updated in Ingeborg Meyer-Palmedo and Gerhard Fichtner's *Freud-Bibliographie mit Werkkonkordanz* (Frankfurt on the Main: S. Fischer, 1989). Our "Freud Bibliography" lists works of Freud according to this system; in each case the title is given in German and in English, along with a reference where applicable to the *Gesammelte Werke* and to the Standard Edition. It should be noted that we list only those works of Freud that are mentioned in the dictionary. Similarly, the "General Bibliography" is confined to works referred to in the text, and is in no sense intended to replace Alexander Grinstein's *Index of Psychoanalytic Writings* (New York: International Universities Press, 1956-75).

"A strange adventure," I wrote at the beginning of this preface, and the reader will perhaps have surmised on the basis of the above description of our *modus operandi* that the going was not always painless, or without its conflicts and clashes, even its moments of despondency. Yet we were always boosted by encouraging words from friends and colleagues who had got wind of our project in its earliest days and, from near or far, followed its progress throughout. Nor did we ever relinquish the conviction that this dictionary would answer a clear need in the analytic profession and among students or researchers who would find it to be a tool unlike any produced thus far.

If there is such a thing as a "language of psychoanalysis," albeit one considered opaque at times by its critics, we are confident that the present work will show it to be neither a wooden nor a dead language. It has grown up from roots shared by all psychoanalysts, but, as the range of our entries shows, from these common origins have sprung a variety of "dialects." Each of them—Adlerian, Jungian, Rankian, Ferenczian, Lacanian, or Bionian—has developed in its own way, and inevitably affected the others in the process. Each, to a greater or lesser degree, has weathered conflict, or eclipse and revival—testimony to a salutary psychoanalytic "heteroglossia," and to the kind of freedom that stimulates thought. The infinite variety of human beings, the diversity of their personal histories and the complexity of a psychological approach that encompasses the dimension of the unconscious can never be forced into the mold of a hypostasized language or submit to the dictates of some Big Brother preparing the "Newspeak" dictionary.

You think, I dare say, that our chief job is inventing new words. But not a bit of it! We're destroying words—scores of them, hundreds of them, every day. We're cutting the language down to the bone. . . .

Don't you see that the whole aim of Newspeak is to narrow the range of thought? In the end we shall make thoughtcrime literally impossible, because there will be no words in which to express it. Every concept that can ever be needed will be expressed by exactly one word, with its meaning rigidly defined. . . . Every year fewer and fewer words, and the range of consciousness always a little smaller (George Orwell, 1984. London: Secker and Warburg, 1987 [1949], pp. 53–54, 55).

*Alea jacta est.* This work is now in the hands of its readers. They are invited to handle it as they will. To contribute notes or offer corrections. To convey to us their critical thoughts and to suggest topics they would like to see dealt with in the future. Such active expressions

of interest would be the best possible reward for me personally and indeed for all those who have lent their hand over these last years to this portrait of psychoanalysis in the world of today.

ALAIN DE MIJOLLA  
PARIS, JUNE 19, 2001

# PREFACE TO THE AMERICAN EDITION

## PREFACE TO THE AMERICAN EDITION

I am thrilled and honored to be a part of the initiative Thomson Gale (represented by Frank Menchaca as well as the highly-effective and ever-smiling Nathalie Duval) has undertaken to share this Dictionary, whose production I directed in France, with an American audience. This enormous and very difficult work has been successfully completed by a highly-motivated team, including (amongst the many others whom I shall not name): Rachel J. Kain, Rita Runchock, and Patricia Kamoun-Bergwerk; the remarkable American advisors Edward Nersessian and Paul Roazen who reviewed all the texts; Nellie Thompson, whose aid was invaluable at various stages in the project; Matthew von Unwerth, who compiled the “Further Readings” sections, and above all, the translators and revisers who fulfilled the difficult task of rendering texts into English that had for the most part been written by authors from France, Spain, Germany, and Portugal.

These translators encountered difficulties raised by more than just the languages in which the authors wrote about these psychoanalytic concepts or biographies they were charged with. Despite a common foundation stemming directly from Freud’s ideas, divergent conceptions leading them to be grasped from slightly more theoretical versus clinical viewpoints, depending on where one is standing, were necessarily in evidence—a fact that had to be both respected and, at the same time, made more accessible to American readers.

However the sheer number of authors and the scope of their starting-points, as much national as related to different schools of psychoanalysis, nonetheless help us to avoid any sort of monolithic thinking, and beckon the reader to go beyond his or her reading of these dictionary entries with research that deepens their insight. For example, we have avoided repeating the precise definitions of terms cited by specific entries that the dictionary defines elsewhere. We have instead trusted that this dictionary would avail itself from page to page, concept to concept, psychoanalyst to psychoanalyst, to the likings of the systematic research or slightly poetic wanderings that constitute the most effective, or the most enlivened, approaches to getting to know a work such as this.

In the Preface to the French edition I offer detailed “directions for use” to readers of this work, so there is no need to revisit that subject. Let me rather use the few lines afforded me here to reiterate the particular importance of this American edition—in my eyes at any rate. It speaks English, like most of the countries in the world today, and English is, of course, an indispensable vector for any thought with claims to universality. Since its humble beginnings in Vienna, psychoanalysis has obviously had a global impact not only in the clinical and therapeutic realms, but also in the arenas of culture and thought. The twentieth and early twenty-first centuries have been marked by ideas whose development has deeply affected the existence of each and every one of us. Our sexual and political lives, our

morality, our ways of understanding our relationships with others—all bear the unmistakable stamp of Freud's legacy. By virtue of his family background and his many-sided education and training, Freud ended up at the point of intersection of cultural influences out of (and against) which psychoanalysis was gradually forged. This dual process, by no means painless, ensured the new discipline a position and multiple functions, which, as we may now plainly see as we look back over the years, have themselves been subject to continual evolution.

A procedure for psychopathological investigation, a method with therapeutic aims, or a conceptual apparatus to account for the workings of the psyche (*l'esprit*) in its external productions as well as its corporeal bonds—out of this ideological and scientific past which Freud conveyed, psychoanalysis has, in turn, modified the conditions of research into the most varied domains of knowledge and none, today, may pretend to be totally beyond its influence.

No matter what position pharmacology assumes, (and we must believe in its progress), the encounter with the mentally ill, the listening to their discourse and the decryption of their delusional sayings in order to glean their secret message, like the patient reestablishing vanished relational capacities, will forever remain an affair that takes place between two human beings, from one psychical apparatus to another. The hope that inspired Jung and Bleuler when they first took responsibility for the schizophrenics in the Burghölzli Asylum was as great as their disappointment. This phenomena repeated itself always and everywhere: Psychoanalysis began by appearing as “The Solution” to the unsolvable problems of mental illness. The example of America, beacon of enthusiasms and of disappointments, is illustrative in this respect—even more spectacularly so in that the all-powerful American Psychoanalytic Association permitted only doctors, psychiatrists for the most part, to join its ranks for the better part of 60 years.

Such is not the case today. Yet even though this puncturing of belief-systems might make us think of a destructive tidal wave, this investigatory drive remains—a drive that mobilizes psychoanalysts for their research into new clinical terrain, as they attempt to shed light on and treat ever more diverse and grave pathological conditions. One day, no doubt, new psychopathological conceptions will effect another exploratory synthesis of the psyche and its dysfunctions, thereby authorizing new avenues of approach that will once again appear to us as nothing short of miraculous. But in the meantime, the patient and modest relational exchange, which underpins the psychoanalytic approach to patients in the psychical domain, remains today's most developed adjuvant therapy, whose ever-greater efficacy and more precise pinpointing may be looked for in the progress of the neurosciences, neurobiology, genetics or immunology.

Although it continues to furnish, as Freud suggested, a “yield of knowledge” for other scientific domains, psychoanalysis gains its creative power and persistent originality from its position on the margins, due to the fact of its being the “other” that cannot be integrated into these disciplines, including literature, history, philosophy, etc. It is the “other” which disrupts through its theoretical *a priori* of a subversive discourse subjacent to all manifest discourse and which, (as the example of Freud himself proves), can never forget that its own words, as well as its thoughts, are condemned to expressing double-meanings, to contradiction, to interrogation; and which could therefore never be thought of as a finished product, a self-enclosed theory, still less a dogma.

The turbulent political events of recent years have refueled the diffusion of psychoanalysis into territories that had previously been closed to it. Therefore both theory and practice will have to rub shoulders with new cultures, languages and other philosophical, religious, medical and scientific traditions. No doubt they will thereby come to brave new storms, know new successes and, fleeting declines. But we must always hope they will be capable of enriching themselves with these various contributions. For only thus is the never-ending

research into the human psyche and its creations embarked upon anew—a quest that constitutes the psychoanalyst's true place in the world of yesterday, today and, for an unforeseeable time still, tomorrow.

Once again, I am particularly pleased and proud that the American edition of this dictionary is contributing, more so than all those that came before it, to extending and diffusing this perpetual renewal of Freudian thought throughout the world.

ALAIN DE MIJOLLA

# INTRODUCTION TO THE AMERICAN EDITION

## INTRODUCTION TO THE AMERICAN EDITION

Psychoanalysis is over 100 years old. Over the course of the 20th century, many new terms and concepts have been added to Freud's original constructs. This evolution has occurred not just in Vienna, Berlin, or Europe, but rather, all over the world. Consequently, new ideas have been formulated throughout and across the increasingly far-flung psychoanalytic community, and despite the existence of an international organization with a rich scientific program, regularly published journals, and an abundance of meetings and exchanges, the language of psychoanalysis is not as uniform as one would expect. Some concepts are understood differently and more importantly, have varying implications in different parts of the world. Other ideas are highly developed and given special status in some countries, while they are unknown or rarely utilized in others. To complicate matters further, schools of thought have developed with variant degrees of deviation from Freud's metapsychology.

A student entering the field of psychoanalysis today has a more difficult task than students of previous generations, in that there is much more to learn and understand, and a greater imperative to be in communication with colleagues in other parts of the world. To integrate the disparate concepts elaborated in different parts of the world, today's practitioner and anyone interested in the history of psychoanalysis must know, understand, and be capable of evaluating many divergent ideas and theoretical constructs. Well-informed dialogue among colleagues from different countries with other perspectives demands that psychoanalysts have a resource—a handbook, so to speak—that provides a brief, concise, but nevertheless sufficiently rigorous exposition of the lexicon of the field.

There have been some attempts in the past to create a dictionary and a glossary of psychoanalysis; *The Language of Psychoanalysis* by Laplanche and Pontalis is one such major effort in this direction; another is the glossary prepared under the aegis of the American Psychoanalytic Association. However, neither of these two works, as useful as they have been, has been able to cover all the disparate concepts, and many analysts have felt the need for an international encyclopedia of psychoanalysis. This need has become even more acute as psychoanalysts have become increasingly interested in facilitating an international exchange of ideas.

When Dr. de Mijolla decided to embark on this project, he was undertaking a Herculean task, but one whose value is unquestionable. Naturally, it would be impossible for one person to develop such an encyclopedia alone, and therefore, it was essential that he obtain the help of psychoanalysts from all over the world. Thus, the 1569 entries in this volume are the work of many contributors, with some contributing more than one entry. While such an arrangement made the timely development of an encyclopedia possible, it also created difficulties in the achievement of a uniform style. On the other hand, there is an



important advantage to this way of proceeding, in that authors known to be experts on a particular subject could contribute an entry in their area of specialization, enhancing the quality of the entries.

A second challenge, and one more specific to the English edition, is the difficulty in translating from the original French text. The team working on this edition has done its best to make the translations as fluid and easily comprehensible as possible. Nevertheless, given the number of translators and the inherent difficulties of interpretation, there may occasionally be a certain degree of rigidity to the sentences or differences from entry to entry. The final product, however, manages to offer a text that is simultaneously eminently approachable and extremely useful.

It will also become clear upon perusing the dictionary that a substantial number of the authors are French. As a result, there is more material on areas of psychoanalysis that have either developed more fully in France or are mostly used by French analysts. This, of course, makes the dictionary a unique source for anyone interested in understanding specific notions and concepts that are prevalent in the thinking of French psychoanalysts. It does, however, engender less coverage of ego psychology, conflict theory, and relational theory by the French authors; moreover, the impression of a negative view of ego psychology, in particular, and American psychoanalysis in general may be an artifact of the composition of the group of contributors. This is not surprising, given the lack of acceptance of Hartman's views in France, particularly by Lacan. Additionally, the animosity that developed between Rudolph Loewenstein and Jacques Lacan had no small hand in the increasingly critical attitude taken by the latter towards ego psychology. Some in France consider ego psychology to be too close to the conscious, and perhaps even too superficial, and therefore are dismissive of it, a viewpoint for which the reader may see evidence in some of the entries. On the other hand, American analysts, if writing about French psychoanalysis, could possibly take a prejudicial attitude and accuse French psychoanalysts of doing "wild analysis." However, with the increase in dialogue and exchange between French and American analysts, these sorts of prejudices are diminishing, and the sharing of perspectives has enriched the members of both groups. As one example of such cross-fertilization, this current edition of the encyclopedia has attempted to present ego psychology and compromise theory in a more balanced way, with the addition of a number of new entries, such as that of Dr. Charles Brenner on modern conflict theory. In addition, to supplement those entries that refer too exclusively to French works, this edition has added a list of suggested readings with references to American sources, compiled by Matthew von Unwerth.

The reader may also notice that the biographies of some prominent psychoanalysts are not mentioned in this volume, as only deceased analysts are included. Unfortunately, some omissions are unavoidable in any reference work that attempts to be as comprehensive as this encyclopedia. Hopefully, the reader will find the addition of photos from the archives of psychoanalysis enlivening and enriching.

Finally, I would like to thank those whose beneficent help made this work not only possible, but even enjoyable. Alain de Mijolla is of course, first and foremost, not only for entrusting me with this task, but also for allowing me a free hand, to a large extent, and for trusting my opinion on those occasions when independent judgment was needed. Nathalie Duval was another important anchor, enormously supportive and unfailingly good-humored, even at the most difficult moments. Her staff, too, was of great help, always in the background, unassuming, but faithfully executing the necessary tasks to ensure the work could proceed smoothly. A special word of thanks goes to the editors and translators whose work could not have been easy, considering the amount of highly technical material that required faithful interpretation. I would particularly like to single out the work of Donald Nicholson-Smith who never ceased to amaze me with his understanding of the semantics of psychoanalytic

language and the elegance and precision of his translations. And, finally, in the end, my gratitude and I am sure that of yours, the reader, goes to the men and women who penned the original entries, as well as a special grateful acknowledgment to those analysts who have added their contributions to this new edition of the encyclopedia.

EDWARD NERSESSIAN

# LIST OF ENTRIES

## LIST OF ENTRIES

### A

“A. Z.”

*Álvaro Rey de Castro*

*Translated by Liam Gavin*

Abandonment

*Jean-Claude Arfouilloux*

*Translated by Liam Gavin*

Abel, Carl

*Laurent Danon-Boileau*

*Translated by Robert Bononno*

Aberastury, Arminda, also known as

“La Negra”

*Eduardo J. Salas*

*Translated by Robert Bononno*

Abraham, Karl

*Johannes Cremerius*

*Translated by Robert Bononno*

Abraham, Nicolas

*Nicholas Rand and Maria Torok*

*Translated by Robert Bononno*

Abstinence/rule of abstinence

*Alain de Mijolla*

*Translated by Dan Collins*

Act/action

*Roger Perron*

*Translated by Robert Bononno*

Acting out/acting in

*Sophie de Mijolla-Mellor*

*Translated by Donald*

*Nicholson-Smith*

Action-(re)presentation

*Roger Perron*

*Translated by Gwendolyn Wells*

Action-language

*Simone Valantin*

*Translated by Gwendolyn Wells*

Action-thought (H. Kohut)

*Agnès Oppenheimer*

*Translated by Donald Nicholson-Smith*

Active imagination (analytical  
psychology)

*Joan Chodorow*

Active technique

*Jean-François Rabain*

*Translated by Dan Collins*

Activity/passivity

*Serge Gauthier*

*Translated by Robert Bononno*

Act, passage to the

*Sophie de Mijolla-Mellor*

*Translated by Dan Collins*

Actual neurosis/defense neurosis

*Claude Smadja*

*Translated by Donald Nicholson-Smith*

Acute psychoses

*Michel Demangeat*

*Translated by Gwendolyn Wells*

Adaptation

*Roger Perron*

*Translated by Robert Bononno*

Addiction

*David Rosenfeld*

*Translated by Robert Bononno*

Adhesive identification

*Robert D. Hinshelwood*

Adler, Alfred

*Helmut Gröger*

*Translated by Robert Bononno*

Adolescence

*Alain Braconnier*

*Translated by Robert Bononno*

Adolescent crisis

*Philippe Jeammet*

*Translated by Robert Bononno*

Adorno, Theodor and Freud

*Sergio Paulo Rouanet*

*Translated by John Galbraith Simmons*

*and Jocelyne Barque*

Agency

*Roger Perron*

*Translated by Gwendolyn Wells*

Aggressiveness/aggression

*Jean Bergeret*

*Translated by Dan Collins*

Aichhorn, August

*Jeanne Moll*

*Translated by Robert Bononno*

Aimée, case of

*Bernard Toboul*

*Translated by Donald Nicholson-Smith*

Ajase complex

*Keigo Okonogi*

Alchemy (analytical psychology)

*Beverley D. Zabriskie*

Alcoholism

*Jean-Paul Descombey*

*Translated by Robert Bononno*

Alexander, Franz Gabriel

*Elke Mühlleitner*

*Translated by Robert Bononno*

Alienation

*Sophie de Mijolla-Mellor*

*Translated by Dan Collins*

Allendy, René Félix Eugène

*Jean-Pierre Bourgeron*

*Translated by Robert Bononno*

Allendy-Nel-Dumouchel, Yvonne

*Jean-Pierre Bourgeron*

*Translated by Robert Bononno*

- Allergic object relationship  
*Robert Asséo*  
*Translated by Robert Bononno*
- Allergy  
*Robert Asséo*  
*Translated by Robert Bononno*
- Allgemeine Ärztliche Gesellschaft für  
Psychotherapie  
*Geoffrey Cocks*  
*Almanach der Psychoanalyse*  
*Andrea Huppke*  
*Translated by Robert Bononno*
- Alpha function  
*Hanna Segal*  
*Translated by Gwendolyn Wells*
- Alpha-elements  
*Hanna Segal*
- Alter ego  
*Agnès Oppenheimer*  
*Translated by Robert Bononno*
- Althusser, Louis  
*Michèle Bertrand*  
*Translated by Robert Bononno*
- Altruism  
*Bernard Golse*  
*Translated by Robert Bononno*
- Alvarez de Toledo, Luisa Augusta  
Rebeca Gambier de  
*Augusto M. Picollo*  
*Translated by Robert Bononno*
- Amae, concept of  
*Takeo Doi*
- Ambivalence  
*Victor Souffir*  
*Translated by Robert Bononno*
- Amentia  
*Augustin Jeanneau*  
*Translated by Robert Bononno*
- American Academy of Psychoanalysis  
*Samuel Slipp*
- American Imago  
*Martin J. Gliserman*
- American Psychoanalytic  
Association  
*Leon Hoffman and Sharon Zalusky*
- Amnesia  
*François Richard*  
*Translated by Donald Nicholson-Smith*
- Amphimixia/amphimixis  
*Pierre Sabourin*  
*Translated by Gwendolyn Wells*
- Amplification (analytical psychology)  
*Andrew Samuels*
- Anaclisis/anaclitic  
*Jean Laplanche*  
*Translated by Donald Nicholson-Smith*
- Anaclitic depression  
*Bernard Golse*  
*Translated by Donald Nicholson-Smith*
- Anagogical interpretation  
*Jacques Angelergues*  
*Translated by Dan Collins*
- Anality  
*Dominique J. Arnoux*  
*Translated by Robert Bononno*
- Anal-sadistic stage  
*Jean-François Rabain*  
*Translated by Donald  
Nicholson-Smith*
- Analysand  
*Alain de Mijolla*  
*Translated by Robert Bononno*
- “Analysis of a Phobia in a  
Five-year-old Boy” (Little Hans )  
*Veronica Mächtlinger*
- “Analysis Terminable and  
Interminable”  
*René Pérán*  
*Translated by Dan Collins*
- Analytic psychodrama  
*Nadine Amar*  
*Translated by John Galbraith Simmons  
and Jocelyne Barque*
- Analytical psychology  
*Murray Stein*
- Analyzability  
*Alain de Mijolla*  
*Translated by Robert Bononno*
- Andersson, Ola  
*Per Magnus Johansson*  
*Translated by Robert Bononno*
- Andreas-Salomé, Louise (Lou)  
*Inge Weber*  
*Translated by Robert Bononno*
- Animal magnetism  
*Jacqueline Carroy*  
*Translated by Robert Bononno*
- Animistic thought  
*Sophie de Mijolla-Mellor*  
*Translated by Liam Gavin*
- Animus-Anima  
*Betty De Shong Meador*
- Anna O., case of  
*Alain de Mijolla*  
*Translated by Robert Bononno*
- Année psychologique, L’-*  
*Annick Ohayon*  
*Translated by Robert Bononno*
- Annihilation anxiety  
*Marvin S. Hurvich*  
*Translated by Liam Gavin*
- Anorexia nervosa  
*Philippe Jeammet*  
*Translated by Liam Gavin*
- Anthropology and psychoanalysis  
*Michèle Porte*  
*Translated by Robert Bononno*
- Anticathexis/counter-cathexis  
*Paul Denis*  
*Translated by Dan Collins*
- Anticipatory ideas  
*Alain de Mijolla*  
*Translated by Gwendolyn Wells*
- Antilibidinal ego/internal  
saboteur  
*Jennifer Johns*
- Antinarcissism  
*Michèle Bertrand*  
*Translated by Dan Collins*
- Anti-Oedipus: Capitalism and  
Schizophrenia*  
*Sylvie Gosme-Séguret*  
*Translated by Gwendolyn Wells*
- Anxiety  
*Francisco Palacio Espasa*  
*Translated by Donald Nicholson-Smith*
- Anxiety dream  
*Roger Perron*  
*Translated by John Galbraith Simmons  
and Jocelyne Barque*
- Anzieu, Didier  
*René Kaës*  
*Translated by Robert Bononno*
- Aphanisis  
*Bernard Golse*  
*Translated by Dan Collins*
- Aphasia  
*Georges Lantéri-Laura*  
*Translated by Robert Bononno*
- Applied psychoanalysis and the  
interaction of psychoanalysis  
*Sophie de Mijolla-Mellor*  
*Translated by Robert Bononno*

- Apprenti-historien et le maître-sorcier (L'-)* [The apprentice historian and the master sorcerer]  
*Ghyslain Charron*  
Translated by Gwendolyn Wells
- Archaic  
*Cléopâtre Athanassiou-Popesco*  
Translated by Robert Bononno
- Archaic mother  
*Sylvain Missonnier*  
Translated by Donald Nicholson-Smith
- Archeology, the metaphor of  
*Sophie de Mijolla-Mellor*  
Translated by Robert Bononno
- Archetype (analytical psychology)  
*Murray Stein*
- Archives de psychologie, Les*  
*Annick Ohayon*  
Translated by Robert Bononno
- Argentina  
*Roberto Doria-Medina Jr, Samuel Arbiser, and Moisés Kijak*  
Translated by Robert Bononno
- Arlow, Jacob  
*Harold P. Blum*
- Armand Trousseau Children's Hospital  
*Frédérique Jacquemain*  
Translated by Liam Gavin
- Arrogance  
*James S. Grotstein*
- As if personality  
*Alain de Mijolla*  
Translated by Liam Gavin
- Association psychanalytique de France  
*Jean-Louis Lang*  
Translated by Robert Bononno
- Asthma  
*Robert Asséo*  
Translated by Liam Gavin
- Asthma in contemporary medicine and psychoanalysis  
*John Galbraith Simmons*
- Attachment  
*Antoine Guédény*  
Translated by Robert Bononno
- Attention  
*Bernard Golse*  
Translated by Dan Collins
- Aubry Weiss, Jenny  
*Marcelle Geber*  
Translated by Robert Bononno
- Aulagnier-Spairani, Piera  
*Sophie de Mijolla-Mellor*  
Translated by Gwendolyn Wells
- Australia  
*O.H.D. Blomfield*
- Austria  
*August Ruhs*  
Translated by Robert Bononno
- Autism  
*Didier Houzel*  
Translated by Dan Collins
- Autistic capsule/nucleus  
*Geneviève Haag*  
Translated by Gwendolyn Wells
- Autistic defenses  
*Elsa Schmid-Kitsikis*  
Translated by Dan Collins
- "Autobiographical Study, An"  
*Sophie de Mijolla-Mellor*  
Translated by Robert Bononno
- Autobiography  
*Sophie de Mijolla-Mellor*  
Translated by Robert Bononno
- Autoeroticism  
*Roger Perron*  
Translated by Robert Bononno
- Autohistorization  
*Sophie de Mijolla-Mellor*  
Translated by Gwendolyn Wells
- Automatism  
*Pascale Michon-Raffaitin*  
Translated by Dan Collins
- Autoplastic  
*Steven Wainrib*  
Translated by Donald Nicholson-Smith
- Autosuggestion  
*Jacqueline Carroy*  
Translated by Robert Bononno
- B**
- Bachelard, Gaston  
*Roger Bruyeron*  
Translated by Robert Bononno
- Baginsky, Adolf  
*Johann Georg Reicheneder*  
Translated by Robert Bononno
- Bak, Robert C.  
*Hungarian Group*
- Balint group  
*Michelle Moreau Ricaud*  
Translated by Dan Collins
- Balint, Michael (Bálint [Bergsmann], Mihály)  
*Judith Dupont*  
Translated by Dan Collins
- Balint-Szekely-Kovács, Alice  
*Judith Dupont*  
Translated by Dan Collins
- Baranger, Willy  
*Madeleine Baranger*  
Translated by Robert Bononno
- Basic assumption  
*Bernard Defontaine*  
Translated by Gwendolyn Wells
- Basic fault  
*Corinne Daubigny*  
Translated by Gwendolyn Wells
- Basic Neurosis, The—Oral Regression and Psychic Masochism*  
*Melvyn L. Iscove*
- Basic Problems of Ethnopsychiatry*  
*Simone Valantin*  
Translated by Robert Bononno
- Baudouin, Charles  
*Mireille Cifali*  
Translated by Robert Bononno
- Bauer, Ida  
*Patrick Mahony*  
Translated by John Galbraith Simmons and Jocelyne Barque
- Beirnaert, Louis  
*Jacques Sédât*  
Translated by Robert Bononno
- Belgium  
*André Alsteens*  
Translated by Robert Bononno
- Belief  
*Odon Vallet*  
Translated by Robert Bononno
- Benedek, Therese  
*Delphine Schilton*  
Translated by Robert Bononno
- Benign/malignant regression  
*Michelle Moreau Ricaud*  
Translated by Gwendolyn Wells
- Berge, André  
*Alain de Mijolla*  
Translated by Robert Bononno
- Berggasse 19, Wien IX

- Ingrid Scholz-Strasser*  
Translated by Robert Bononno
- Bergler, Edmund  
*Melvyn L. Iscove*
- Berliner Psychoanalytische Poliklinik  
*Regine Lockot*  
Translated by Liam Gavin
- Berliner Psychoanalytisches Institut  
*Regine Lockot*  
Translated by John Galbraith Simmons  
and Jocelyne Barque
- Berman, Anne  
*Jean-Pierre Bourgeron*  
Translated by Robert Bononno
- Bernays-Freud, Minna  
*Albrecht Hirschmüller*  
Translated by Robert Bononno
- Bernfeld, Siegfried  
*R. Horacio Etchegoyen*  
Translated by Robert Bononno
- Bernheim, Hippolyte  
*Jacqueline Carroy*  
Translated by Robert Bononno
- Beta-elements  
*Hanna Segal*
- Beta-screen  
*Hanna Segal*
- Bettelheim, Bruno  
*Nina Sutton*  
Translated by Sophie Leighton
- Beyond the Pleasure Principle*  
*Michèle Porte*  
Translated by Robert Bononno
- Biblioteca Nueva de Madrid (Freud,  
S., *Obras Completas*)  
*José Gutiérrez Terrazas*  
Translated by Robert Bononno
- Bibring, Edward  
*Elke Mühlleitner*  
Translated by Robert Bononno
- Bibring-Lehner, Grete  
*Elke Mühlleitner*  
Translated by Robert Bononno
- Bick, Esther  
*Bernard Golse*  
Translated by Robert Bononno
- Bigras, Julien Joseph Normand  
*Élisabeth Bigras*  
Translated by Robert Bononno
- Binding/unbinding of the instincts  
*Pierre Delion*
- Translated by Gwendolyn Wells
- Binswanger, Ludwig  
*Ruth Menahem*  
Translated by Robert Bononno
- Biological bedrock  
*Michèle Porte*  
Translated by Donald Nicholson-Smith
- Bion, Wilfred Ruprecht  
*Parthenope Bion Talamo*
- Bipolar self  
*Agnès Oppenheimer*  
Translated by Gwendolyn Wells
- Birth  
*Didier Houzel*  
Translated by Liam Gavin
- Birth, dream of  
*Roger Perron*  
Translated by Gwendolyn Wells
- Bisexuality  
*Paulo R. Ceccarelli*  
Translated by Dan Collins
- Bizarre object  
*Edna O'Shaughnessy*
- Bjerre, Poul  
*Per Magnus Johansson*  
Translated by Robert Bononno
- Black hole  
*Bernard Golse*  
Translated by Donald Nicholson-Smith
- Blackett-Milner, Marion  
*Didier Rabain*  
Translated by Liam Gavin
- Blank/nondelusional psychoses  
*Michel Demangeat*  
Translated by Gwendolyn Wells
- Blanton, Smiley  
*Alain de Mijolla*  
Translated by Robert Bononno
- Bleger, José  
*Susana Beatriz Dupetit*  
Translated by Robert Bononno
- Bleuler, Paul Eugen  
*Bernard Minder*  
Translated by Robert Bononno
- Bloc—Notes de la psychanalyse*  
*Mario Cifali*  
Translated by Robert Bononno
- Bloch, Jean-Richard  
*Michelle Moreau Ricaud*  
Translated by Robert Bononno
- Blos, Peter
- Florian Houssier*  
Translated by Robert Bononno
- Body image  
*David Rosenfeld*
- Boehm, Felix Julius  
*Regine Lockot*  
Translated by John Galbraith Simmons  
and Jocelyne Barque
- Bonaparte, Marie Léon  
*Jean-Pierre Bourgeron*  
Translated by Robert Bononno
- Book of the It, The*  
*Herbert Will*  
Translated by Liam Gavin
- Borderline conditions  
*Augustin Jeanneau*  
Translated by Robert Bononno
- Boredom  
*Sophie de Mijolla-Mellor*  
Translated by Robert Bononno
- Borel, Adrien Alphonse Alcide  
*Nadine Mespoulhès*  
Translated by Robert Bononno
- Bornstein, Berta  
*Simone Valantin*  
Translated by Liam Gavin
- Bose, Girindrasekhar  
*Sudhir Kakar*  
Translated by Robert Bononno
- Boston Psychoanalytic Society  
*Sanford Gifford*
- Boundary violations  
*Glen O. Gabbard*
- Bouvet, Maurice Charles Marie  
Germain  
*Alain de Mijolla*  
Translated by Robert Bononno
- Bowlby, Edward John Mostyn  
*Nicole Guédény*  
Translated by Robert Bononno
- Brain and psychoanalysis, the  
*Daniel Widlöcher*  
Translated by Robert Bononno
- Brazil  
*Marialzira Perestrello*  
Translated by Liam Gavin
- Breakdown  
*Denys Ribas*  
Translated by Robert Bononno
- Breast, good/bad object  
*Robert D. Hinshelwood*

- Breastfeeding  
*Joyceline Siksou*  
Translated by Robert Bononno
- Brentano, Franz von  
*Alain de Mijolla*  
Translated by Robert Bononno
- Breton, André  
*Nicole Geblesco*  
Translated by Robert Bononno
- Breuer, Josef  
*Albrecht Hirschmüller*  
Translated by Robert Bononno
- Brierley, Marjorie Flowers  
*Anne Hayman*
- Brill, Abraham Arden  
*Arnold D. Richards*
- British Psycho-Analytical Society  
*Pearl King and Riccardo Steiner*
- Brücke, Ernst Wilhelm von  
*Helmut Gröger*  
Translated by Robert Bononno
- Brun, Rudolf  
*Kaspar Weber*  
Translated by Robert Bononno
- Brunswick, Ruth Mack  
*Paul Roazen*
- Bulimia  
*Christine Vindreau*  
Translated by Liam Gavin
- Bullitt, William C.  
*Paul Roazen*
- Burghölzli Asylum  
*Bernard Minder*  
Translated by Robert Bononno
- Burlingham-Tiffany, Dorothy  
*Bernard Golse*  
Translated by John Galbraith Simmons  
and Jocelyne Barque
- Burrow, Trigant  
*Malcolm Pines*
- C**
- Cäcilie M., case of  
*Alain de Mijolla*  
Translated by Robert Bononno
- Cahiers Confrontation, Les*  
*Chantal Talagrand*
- Canada  
*Jacques Vigneault*  
Translated by Robert Bononno
- Capacity to be alone  
*Jean-Bertrand Pontalis*  
Translated by Donald Nicholson-Smith
- Cárcamo, Celes Ernesto  
*Roberto Doria-Medina Jr*  
Translated by Robert Bononno
- Caruso, Igor A.  
*August Ruhs*  
Translated by Robert Bononno
- Case histories  
*Sophie de Mijolla-Mellor*  
Translated by Liam Gavin
- Castration complex  
*Jean Bergeret*  
Translated by Donald Nicholson-Smith
- Catastrophe theory and  
psychoanalysis  
*Michèle Porte*  
Translated by Robert Bononno
- Catastrophic change  
*James S. Grotstein*
- Cathartic method  
*Alain de Mijolla*  
Translated by John Galbraith Simmons  
and Jocelyne Barque
- Cathectic energy  
*Paul Denis*  
Translated by Dan Collins
- Cathexis  
*Paul Denis*  
Translated by Gwendolyn Wells
- Cénac, Michel  
*Jean-Pierre Bourgeron*  
Translated by Robert Bononno
- Censoring the lover in her  
*Michel Ody and Laurent*  
*Danon-Boileau*  
Translated by Liam Gavin
- Censorship  
*Roger Perron*  
Translated by Liam Gavin
- Centre Alfred-Binet  
*Gérard Lucas*  
Translated by Liam Gavin
- Centre de consultations et de  
traitements psychanalytiques  
*Jean-Favreau*  
*Jean-Luc Donnet*  
Translated by Liam Gavin
- Centre psychopédagogique  
*Claude-Bernard*  
*Claire Doz-Schiff*  
Translated by Liam Gavin
- Certainty  
*Sophie de Mijolla-Mellor*  
Translated by Robert Bononno
- Certeau, Michel de  
*François Dosse*  
Translated by Robert Bononno
- Change  
*Daniel Widlöcher*  
Translated by Gwendolyn Wells
- Character  
*Robert Asséo*  
Translated by Gwendolyn Wells
- Character Analysis*  
*Roger Dadoun*  
Translated by Dan Collins
- Character formation  
*Sophie de Mijolla-Mellor*  
Translated by Gwendolyn Wells
- Character neurosis  
*Robert Asséo*  
Translated by Gwendolyn Wells
- Charcot, Jean Martin  
*Alain de Mijolla*  
Translated by Robert Bononno
- Chentrier, Théodore  
*André Michel*  
Translated by Robert Bononno
- Chertok, Léon (Tchertok, Lejb)  
*Alain de Mijolla*  
Translated by Robert Bononno
- Chicago Psychoanalytic Institute  
*John Galbraith Simmons*
- Child analysis  
*Antoine Guédeney*  
Translated by Gwendolyn Wells
- Childhood  
*Claudine Geissmann*  
Translated by Robert Bononno
- Childhood and Society*  
*Paul Roazen*  
Translated by Gwendolyn Wells
- Children's play  
*Nora Kurts*  
Translated by Donald Nicholson-Smith
- Chile  
*Omar Arrué*  
Translated by Robert Bononno
- China  
*Geoffrey H. Blowers and Teresa Yuan*
- Choice of neurosis  
*Daniel Widlöcher*  
Translated by Robert Bononno

- Choisy, Maryse  
*Jacqueline Cosnier*  
Translated by Robert Bononno  
*Christians and Jews: A Psychoanalytical Study*  
*Michelle Moreau Ricaud*  
Translated by John Galbraith Simmons and Jocelyne Barque
- Cinema and psychoanalysis  
*Pierre-Jean Bouyer and Sylvain Bouyer*  
Translated by Robert Bononno
- Cinema criticism  
*Glen O. Gabbard*
- Civilization (*Kultur*)  
*Sophie de Mijolla-Mellor*  
Translated by Robert Bononno  
*Civilization and its Discontents*  
*Michèle Porte*  
Translated by Robert Bononno
- “Claims of Psychoanalysis to Scientific Interest”  
*Alain de Mijolla*  
Translated by Liam Gavin
- Claparède, Édouard  
*Mireille Cifali*  
Translated by Robert Bononno
- Clark University  
*Robert Shilkret*
- Clark-Williams, Margaret  
*Georges Schopp*  
Translated by John Galbraith Simmons and Jocelyne Barque
- Claude, Henri Charles Jules  
*Alain de Mijolla*  
Translated by Robert Bononno
- Claustrophobia  
*Laurent Muldworf*  
Translated by Robert Bononno
- Clinging instinct  
*Hungarian Group*
- Cocaine and psychoanalysis  
*David Rosenfeld*  
Translated by Liam Gavin
- Cognitivism and psychoanalysis  
*Daniel Widlöcher*  
Translated by Robert Bononno  
*Collected Papers on Schizophrenia and Related Subjects*  
*Richard M. Waugaman*
- Collective psychology  
*Michèle Porte*
- Translated by Gwendolyn Wells
- Collective unconscious (analytical psychology)  
*David I. Trésan*
- Collège de psychanalystes  
*Jacques Sédat*  
Translated by Robert Bononno
- Colloque sur l’ inconscient  
*Georges Lantéri-Laura*  
Translated by Robert Bononno
- Colombia  
*Guillermo Sanchez Medina*  
Translated by Liam Gavin
- Combined parent figure  
*Robert D. Hinshelwood*
- Compensation (analytical psychology)  
*Peter Mudd*
- Compensatory structures  
*Arnold Goldberg*  
Translated by Andrew Brown
- Complemental series  
*Bernard Golse*  
Translated by Liam Gavin
- Complex  
*Roger Perron*  
Translated by Dan Collins
- Complex (analytical psychology)  
*Verena Kast*  
Translated by Dan Collins
- Compromise formation  
*Roger Perron*  
Translated by Dan Collins
- Compulsion  
*Gérard Bonnet*  
Translated by Robert Bononno
- Concept  
*Pedro Luzes*  
Translated by Robert Bononno
- Condensation  
*Laurent Danon-Boileau*  
Translated by Liam Gavin
- Conflict  
*Roger Perron*  
Translated by Gwendolyn Wells
- Confrontation  
*Chantal Talagrand*
- “Confusion of Tongues between Adults and the Child”  
*Pierre Sabourin*  
Translated by Sophie Leighton
- Congrès des psychanalystes de langue française des pays romans  
*Alain de Mijolla*  
Translated by Liam Gavin
- Congrès international de l’hypnotisme expérimental et scientifique, Premier  
*François Duyckaerts*  
Translated by Robert Bononno
- Conscious processes  
*Raymond Cahn*  
Translated by Donald Nicholson-Smith
- Consciousness  
*Raymond Cahn*  
Translated by Donald Nicholson-Smith
- Constitution  
*Claude Smadja*  
Translated by Liam Gavin  
*Construction de l’espace analytique (La-)[Constructing the analytical space]*  
*Sophie de Mijolla-Mellor*  
Translated by Liam Gavin
- Construction/reconstruction  
*Sophie de Mijolla-Mellor*  
Translated by Liam Gavin
- “Constructions in Analysis”  
*Christian Seulin*  
Translated by Robert Bononno
- Contact and psychoanalysis  
*Bernard This*  
Translated by Robert Bononno
- Contact-barrier  
*Hanna Segal*
- Container-Contained  
*Jean-Claude Guillaume*  
Translated by Gwendolyn Wells
- Contradiction  
*Michèle Porte*  
Translated by Dan Collins
- “Contributions to the Psychology of Love”  
*Roger Perron*  
Translated by Donald Nicholson-Smith
- Controversial Discussions  
*Riccardo Steiner*
- Convenience, dream of  
*Roger Perron*  
Translated by Gwendolyn Wells
- Conversion  
*Roger Perron*  
Translated by Robert Bononno



- Coprophilia  
*Dominique J. Arnoux*  
*Translated by Liam Gavin*
- Coq-Héron, Le*  
*Judith Dupont*  
*Translated by Robert Bononno*
- Corrao, Francesco  
*Anna Maria Accerboni*  
*Translated by Robert Bononno*
- Counter-identification  
*Alain de Mijolla*  
*Translated by Dan Collins*
- Counter-Oedipus  
*Roger Perron*  
*Translated by Dan Collins*
- Counterphobic  
*Francis Drossart*  
*Translated by Gwendolyn Wells*
- Counter-transference  
*Claudine Geissmann*  
*Translated by Dan Collins*
- “Creative Writers and Day-Dreaming”  
*Sophie de Mijolla-Mellor*  
*Translated by Robert Bononno*
- Creativity  
*Sophie de Mijolla-Mellor*  
*Translated by Robert Bononno*
- Criminology and psychoanalysis  
*Daniel Zagury*  
*Translated by Robert Bononno*
- Cruelty  
*Annette Fréjaville*  
*Translated by Robert Bononno*
- Cryptomnesia  
*Erik Porge*  
*Translated by Gwendolyn Wells*
- Cultural transmission  
*Madeleine Baranger*  
*Translated by Gwendolyn Wells*
- Cure  
*Alain de Mijolla*  
*Translated by Dan Collins*
- Czech Republic  
*Michael Sebek*
- D**
- Dalbiez, Roland  
*Annick Ohayon*  
*Translated by Robert Bononno*
- Danger  
*Claude Barrois*  
*Translated by Robert Bononno*
- Dark continent  
*Julia Kristeva*  
*Translated by Robert Bononno*
- Darwin, Darwinism, and psychoanalysis  
*Roger Perron*  
*Translated by Robert Bononno*
- Day's residues  
*Roger Perron*  
*Translated by Gwendolyn Wells*
- Dead mother complex  
*André Green*  
*Translated by Sophie Leighton*
- Death and psychoanalysis  
*Sophie de Mijolla-Mellor*  
*Translated by Robert Bononno*
- Death instinct (Thanatos)  
*Pierre Delion*  
*Translated by Sophie Leighton*
- Decathexis  
*Paul Denis*  
*Translated by Liam Gavin*
- Defense  
*Elsa Schmid-Kitsikis*  
*Translated by Gwendolyn Wells*
- Defense mechanisms  
*Elsa Schmid-Kitsikis*  
*Translated by Gwendolyn Wells*
- Deferred action  
*Jean Laplanche*  
*Translated by Donald Nicholson-Smith*
- Deferred action and trauma  
*Odile Lesourne*  
*Translated by Donald Nicholson-Smith*
- Déjà vu  
*Sophie de Mijolla-Mellor*  
*Translated by Robert Bononno*
- Delay, Jean  
*Claude Delay*  
*Translated by Robert Bononno*
- Delboeuf, Joseph Rémi Léopold  
*François Duyckaerts*  
*Translated by Robert Bononno*
- Delgado, Honorio  
*Álvaro Rey de Castro*  
*Translated by Robert Bononno*
- Delusion  
*Augustin Jeanneau*  
*Translated by Robert Bononno*
- Delusions and Dreams in Jensen's*  
*“Gradiva”*  
*Roger Perron*
- Translated by Sophie Leighton*
- Demand  
*Gabriel Balbo*  
*Translated by Dan Collins*
- Dementia  
*Richard Uhl*  
*Translated by Gwendolyn Wells*
- Denmark  
*Ole Andkjær Olsen*  
*Translated by Robert Bononno*
- Dependence  
*Bénédicte Bonnet-Vidon*  
*Translated by Robert Bononno*
- Depersonalization  
*Paul Denis*  
*Translated by Robert Bononno*
- Depression  
*Francisco Palacio Espasa*
- Depressive position  
*Robert D. Hinshelwood*
- Deprivation  
*Grazia Maria Fava Vizziello*  
*Translated by Robert Bononno*
- Desexualization  
*Marc Bonnet*  
*Translated by Robert Bononno*
- Desoille, Robert  
*Jacques Launay*  
*Translated by Robert Bononno*
- Destrudo  
*Bernard Golse*  
*Translated by Robert Bononno*
- Determinism  
*Dominique Auffret*  
*Translated by Robert Bononno*
- Detski Dom  
*Irina Manson*  
*Translated by Robert Bononno*
- Deuticke, Franz  
*Lydia Marinelli*  
*Translated by Robert Bononno*
- Deutsch, Felix  
*Paul Roazen*
- Deutsches Institut für Psychologische  
Forschung und Psychotherapie  
(Institut Göring)  
*Geoffrey Cocks*
- Deutsch-Rosenbach, Helene  
*Paul Roazen*  
*Development of Psycho-Analysis*

- Corinne Daubigny*  
*Translated by Gwendolyn Wells*
- Developmental disorders  
*Roger Perron*  
*Translated by Liam Gavin*
- Devereux, Georges  
*Simone Valantin*  
*Translated by Robert Bononno*
- Diatkine, René  
*Florence Quartier-Frings*  
*Translated by Robert Bononno*
- Dipsomania  
*Jean-Paul Descombey*  
*Translated by Gwendolyn Wells*
- Direct analysis  
*Roger Perron*  
*Translated by Robert Bononno*
- Directed daydream (R. Desoille)  
*Jacques Launay*  
*Translated by Gwendolyn Wells*
- Disavowal  
*Bernard Penot*  
*Translated by Robert Bononno*
- Discharge  
*Alain Fine*  
*Translated by Gwendolyn Wells*
- Disintegration products  
*Arnold Goldberg*  
*Translated by Andrew Brown*
- Disintegration, feelings of, anxieties  
*Alain de Mijolla*  
*Translated by Gwendolyn Wells*
- Dismantling  
*Geneviève Haag*  
*Translated by Gwendolyn Wells*
- Disorganization  
*Claude Smadja*  
*Translated by Robert Bononno*
- Displacement  
*Elsa Schmid-Kitsikis*  
*Translated by Gwendolyn Wells*
- Displacement of the transference  
*François Duparc*  
*Translated by Dan Collins*
- Disque vert, Le*  
*Alain de Mijolla*  
*Translated by Robert Bononno*
- “Disturbance of Memory on the Acropolis, A”  
*Henri Vermorel*  
*Translated by Donald Nicholson-Smith*
- Documents et Débats*  
*Jean-Yves Tamet*  
*Translated by Robert Bononno*
- Dolto-Marette, Françoise  
*Bernard This*  
*Translated by Sophie Leighton*
- Don Juan and The Double*  
*Sophie de Mijolla-Mellor*  
*Translated by Robert Bononno*
- Doolittle-Aldington, Hilda (H.D.)  
*Alain de Mijolla*  
*Translated by John Galbraith Simmons*  
*and Jocelyne Barque*
- “Dostoyevsky and Parricide”  
*Marie-Thérèse Neyraut-Sutterman*  
*Translated by Robert Bononno*
- Dosuzkov, Theodor  
*Eugenie Fischer and René Fischer*  
*Translated by Liam Gavin*
- Double bind  
*Jean-Pierre Caillot*  
*Translated by Liam Gavin*
- Double, the  
*Sophie de Mijolla-Mellor*  
*Translated by Robert Bononno*
- Doubt  
*Sophie de Mijolla-Mellor*  
*Translated by Robert Bononno*
- Dream  
*Roger Perron*  
*Translated by Robert Bononno*
- Dream interpretation  
*Roger Perron*  
*Translated by Robert Bononno*
- Dream-like memory  
*Didier Houzel*  
*Translated by Liam Gavin*
- “Dream of the Wise Baby, The”  
*Pierre Sabourin*  
*Translated by Liam Gavin*
- Dream screen  
*Bernard Golse*  
*Translated by Donald Nicholson-Smith*
- Dream symbolism  
*Roger Perron*  
*Translated by Donald Nicholson-Smith*
- Dream work  
*Roger Perron*  
*Translated by Sophie Leighton*
- Dreams and Myths*  
*Johannes Cremerius*  
*Translated by Gwendolyn Wells*
- Dream’s navel  
*Roger Perron*  
*Translated by Liam Gavin*
- Drive/instinct  
*Michèle Porte*  
*Translated by Dan Collins*
- Dualism  
*Michèle Porte*  
*Translated by Robert Bononno*
- Dubal, George  
*Mario Cifali*  
*Translated by Liam Gavin*
- Dugautiez, Maurice  
*Daniel Luminet*  
*Translated by Liam Gavin*
- Dynamic point of view  
*René Roussillon*  
*Translated by Liam Gavin*
- ## E
- Early interactions  
*Bernard Golse*  
*Translated by Liam Gavin*
- Eckstein, Emma  
*Bertrand Vichyn*  
*Translated by Robert Bononno*
- École de la Cause freudienne  
*Jacques Sédat*  
*Translated by Dan Collins*
- École expérimentale de Bonneuil  
*Michel Polo*  
*Translated by Gwendolyn Wells*
- École freudienne de Paris (Freudian School of Paris)  
*Jacques Sédat*  
*Translated by Dan Collins*
- Economic point of view  
*René Roussillon*  
*Translated by Liam Gavin*
- Écrits  
*Jacques Sédat*  
*Translated by Dan Collins*
- Eder, David Montagu  
*Michelle Moreau Ricaud*  
*Translated by Robert Bononno*
- Ego  
*Alain de Mijolla*  
*Translated by Donald Nicholson-Smith*
- Ego, alteration of the  
*Ernst Federn*  
*Translated by Donald Nicholson-Smith*

- Ego (analytical psychology)  
Mario Jacoby  
*Translated by Sophie Leighton*
- Ego and the Id, The*  
Jean-Luc Donnet  
*Translated by Donald Nicholson-Smith*
- Ego and the Mechanisms of Defense, The*  
Elsa Schmid-Kitsikis  
*Translated by Donald Nicholson-Smith*
- Ego autonomy  
Marvin S. Hurvich
- Ego boundaries  
Marvin S. Hurvich
- Ego, damage inflicted on  
Ernst Federn  
*Translated by Donald Nicholson-Smith*
- Ego (ego psychology)  
Ernst Federn  
*Translated by Donald Nicholson-Smith*
- Ego feeling  
Marvin S. Hurvich
- Ego functions  
Ernst Federn  
*Translated by Donald Nicholson-Smith*
- Ego ideal  
Sophie de Mijolla-Mellor  
*Translated by Robert Bononno*
- Ego ideal/ideal ego  
Bernard Penot  
*Translated by Andrew Brown*
- Ego identity  
Paul Roazen  
*Translated by Gwendolyn Wells*
- Ego-instinct  
Pierre Delion  
*Translated by Dan Collins*
- Ego interests  
Ernst Federn  
*Translated by Donald Nicholson-Smith*
- Ego-libido/object-libido  
Alain de Mijolla  
*Translated by Gwendolyn Wells*
- Ego psychology  
Marvin S. Hurvich  
*Ego Psychology and the Problem of Adaptation*  
Ernst Federn  
*Translated by Donald Nicholson-Smith*  
*Ego Psychology and the Psychoses*  
Marvin S. Hurvich
- Ego states  
Marvin S. Hurvich
- Ego-syntonic  
Ernst Federn  
*Translated by Donald Nicholson-Smith*
- Eissler, Kurt Robert  
Clifford Yorke
- Eissler-Selke, Ruth  
Elke Mühlleitner  
*Translated by John Galbraith Simmons and Jocelyne Barque*
- Eitingon, Max  
Michelle Moreau Ricaud  
*Translated by Robert Bononno*
- Elasticity  
Pierre Sabourin  
*Translated by Liam Gavin*
- Elementi di psiocoanalisi*  
Anna Maria Accerboni  
*Translated by Robert Bononno*
- Elisabeth von R., case of  
Alain de Mijolla  
*Translated by Robert Bononno*
- Ellenberger, Henri Frédéric  
Alain de Mijolla  
*Translated by Robert Bononno*
- Embirikos, Andreas  
Anna Potamianou  
*Translated by Robert Bononno*
- Emden, Jan Egbert Gustaaf van  
Jaap Bos and Christien Brinkgreve
- Emmy von N., case of  
Alain de Mijolla  
*Translated by Robert Bononno*
- Emotion  
Didier Houzel  
*Translated by Robert Bononno*
- Empathy  
Daniel Widlöcher  
*Translated by Robert Bononno*
- Empty Fortress, The*  
Nina Sutton  
*Translated by Donald Nicholson-Smith*
- Encopresis  
Gérard Schmit  
*Translated by Gwendolyn Wells*
- Encounter  
Sophie de Mijolla-Mellor  
*Translated by Sophie Leighton*
- Enriquez-Joly, Micheline Eugène  
Enriquez  
*Translated by Robert Bononno*
- Enuresis  
Gérard Schmit  
*Translated by John Galbraith Simmons and Jocelyne Barque*
- Envy  
Robert D. Hinshelwood  
*Envy and Gratitude*  
Robert D. Hinshelwood
- Erikson, Erik Homburger  
Paul Roazen
- Eros  
Roland Gori  
*Translated by Robert Bononno*
- Eroticism, anal  
Dominique J. Arnoux  
*Translated by Dan Collins*
- Eroticism, oral  
Dominique J. Arnoux  
*Translated by Philip Beitchman*
- Eroticism, urethral  
Dominique J. Arnoux  
*Translated by Dan Collins*
- Erotogenic masochism  
Denys Ribas  
*Translated by Gwendolyn Wells*
- Erotogenic zone  
Sophie de Mijolla-Mellor  
*Translated by Donald Nicholson-Smith*
- Erotogenicity  
Roland Gori  
*Translated by Liam Gavin*
- Erotomania  
Michel Demangeat  
*Translated by Robert Bononno*
- Erythrophobia (fear of blushing)  
Bernard Golse  
*Translated by Liam Gavin*
- Essential depression  
Alain Fine  
*Translated by Gwendolyn Wells*
- Estrangement  
Sophie de Mijolla-Mellor  
*Translated by Robert Bononno*
- Ethics  
Roland Gori  
*Translated by Dan Collins*
- Ethnopsyoanalysis  
Marie-Rose Moro  
*Translated by Robert Bononno*
- Ethology and psychoanalysis

- Boris Cyrulnik*  
*Translated by Robert Bononno*
- Études Freudiennes*  
*Danièle Brun*  
*Translated by Sophie Leighton*
- European Psychoanalytical  
Federation  
*Alain Gibeault*  
*Translated by Robert Bononno*
- Evenly-suspended attention  
*Alain de Mijolla*  
*Translated by Sophie Leighton*
- Évolution psychiatrique (I' -)*  
(Developments in Psychiatry)  
*Jean Garrabé*  
*Translated by Liam Gavin*
- Examination dreams  
*Roger Perron*  
*Translated by Liam Gavin*
- Excitation  
*Alain Fine*  
*Translated by Gwendolyn Wells*
- Exhibitionism  
*Delphine Schilton*  
*Translated by Donald Nicholson-Smith*
- Experience of satisfaction  
*Bernard Golse*  
*Translated by Gwendolyn Wells*
- Externalization-internalization  
*Delphine Schilton*  
*Translated by Gwendolyn Wells*
- Extroversion/introversion (analytical  
psychology)  
*Marie-Laure Grivet-Shillito*  
*Translated by Gwendolyn Wells*
- Ey, Henri  
*Jean Garrabé*  
*Translated by Robert Bononno*
- F**
- Face-to-face situation  
*Alain de Mijolla*  
*Translated by Gwendolyn Wells*
- Facilitation  
*Bertrand Vichyn*  
*Translated by Gwendolyn Wells*
- Fackel, Die*  
*Erik Porge*  
*Translated by Robert Bononno*
- Failure neurosis  
*Alain de Mijolla*  
*Translated by Liam Gavin*
- Fairbairn, William Ronald Dodds  
*Jennifer Johns*
- False self  
*Jennifer Johns*
- Family  
*Alberto Eiguer*  
*Translated by Robert Bononno*
- Family romance  
*Sophie de Mijolla-Mellor*  
*Translated by John Galbraith Simmons*  
*and Jocelyne Barque*
- Fanon, Frantz  
*Guillaume Suréna*  
*Translated by Robert Bononno*
- Fantasy  
*Roger Perron*  
*Translated by Robert Bononno*
- Fantasy, formula of  
*Bernard Penot*  
*Translated by Dan Collins*
- Fantasy (reverie)  
*Roger Perron*  
*Translated by Robert Bononno*
- Fascination  
*Catherine Desprats-Péquignot*  
*Translated by Robert Bononno*
- Fate neurosis  
*Alain de Mijolla*  
*Translated by Sophie Leighton*
- Father complex  
*Roger Perron*  
*Translated by Sophie Leighton*
- Fatherhood  
*Anne Aubert-Godard*  
*Translated by Sophie Leighton*
- Favez, Georges  
*Bernard Golse*  
*Translated by Robert Bononno*
- Favez-Boutonier, Juliette  
*Bernard Golse*  
*Translated by Robert Bononno*
- Favreau, Jean Alphonse  
*Marie-Thérèse Montagnier*  
*Translated by Gwendolyn Wells*
- Fear  
*Claude Bursztejn*  
*Translated by Robert Bononno*
- Feces  
*Dominique J. Arnoux*  
*Translated by Gwendolyn Wells*
- Fechner, Gustav Theodor  
*Bernd Nitzschke*
- Translated by John Galbraith Simmons*  
*and Jocelyne Barque*
- Federación psicoanalítica de  
América latina  
*Cláudio Laks Eizirik*  
*Translated by Gwendolyn Wells*
- Federn, Paul  
*Anna Maria Accerboni*  
*Translated by Robert Bononno*
- Fedida, Pierre  
*Sophie de Mijolla-Mellor*  
*Translated by Sophie Leighton*
- Female sexuality  
*Julia Kristeva*  
*Translated by Donald Nicholson-Smith*
- Feminine masochism  
*Denys Ribas*  
*Translated by Gwendolyn Wells*
- Femininity  
*Monique Schneider*  
*Translated by Sophie Leighton*
- Femininity, rejection of  
*Monique Schneider*  
*Translated by Dan Collins*
- Feminism and psychoanalysis  
*Rosine Jozef Perelberg*  
*Translated by Donald Nicholson-Smith*
- Fenichel, Otto  
*Elke Mühlleitner*  
*Translated by Robert Bononno*
- Ferenczi, Sándor  
*Éva Brabant-Gerö*  
*Translated by Robert Bononno*
- Fetishism  
*André Lussier*  
*Translated by Robert Bononno*
- Finland  
*Per Magnus Johansson*  
*Translated by Robert Bononno*
- First World War: The effect on the  
development of psychoanalysis  
*Alain de Mijolla*  
*Translated by Robert Bononno*
- Five Lectures on Psycho-Analysis*  
*Maité Klahr and Claudie Millot*  
*Translated by Sophie Leighton*
- Fixation  
*Claude Smadja*  
*Translated by Dan Collins*
- Fliess, Wilhelm  
*Erik Porge*  
*Translated by Robert Bononno*

- Flight into illness  
*Alain Fine*  
*Translated by John Galbraith Simmons and Jocelyne Barque*
- Flournoy, Henri  
*Olivier Flournoy*  
*Translated by Robert Bononno*
- Flournoy, Théodore  
*Olivier Flournoy*  
*Translated by Robert Bononno*
- Flower Doll: *Essays in Child Psychotherapy*  
*Bernard This*  
*Translated by Liam Gavin*
- Flügel, John Carl  
*Alain de Mijolla*  
*Translated by Robert Bononno*
- Fluss, Gisela  
*Alain de Mijolla*  
*Translated by Robert Bononno*
- Foreclosure  
*Charles Melman*  
*Translated by Gwendolyn Wells*
- Forgetting  
*François Richard*  
*Translated by Robert Bononno*
- Formations of the unconscious  
*Alain Vanier*  
*Translated by Dan Collins*
- Fornari, Franco  
*Giancarlo Gramaglia*  
*Translated by Robert Bononno*
- Fort-Da  
*Gérard Bonnet*  
*Translated by Donald Nicholson-Smith*
- Foulkes (Fuchs), Siegmund Heinrich  
*Malcolm Pines*
- Four discourses  
*Joël Dor*  
*Translated by Dan Collins*
- Fourth analysis  
*Sophie de Mijolla-Mellor*  
*Translated by Dan Collins*
- “Fragment of an Analysis of a Case of Hysteria” (Dora/Ida Bauer)  
*Patrick Mahony*
- Fragmentation  
*Agnès Oppenheimer*  
*Translated by Gwendolyn Wells*
- Framework of the psychoanalytic treatment  
*Alain de Mijolla*  
*Translated by Robert Bononno*
- France  
*Alain de Mijolla*  
*Translated by Robert Bononno*
- Franco da Rocha, Francisco  
*Fabio Herrmann and Roberto Yutaka Sagawa*  
*Translated by Gwendolyn Wells*
- Frankl, Viktor  
*Jacques Sédard*  
*Translated by John Galbraith Simmons and Jocelyne Barque*
- Free association  
*Alain de Mijolla*  
*Translated by Robert Bononno*
- Free energy/bound energy  
*Bertrand Vichyn*  
*Translated by Sophie Leighton*
- Freud, Anna  
*Clifford Yorke*
- Freud-Bernays, Martha  
*Clifford Yorke*
- Freud, Ernst  
*Alain de Mijolla*  
*Translated by Robert Bononno*
- Freud, Jakob Kolloman (or Keleman or Kallamon)  
*Alain de Mijolla*  
*Translated by Robert Bononno*
- Freud, (Jean) Martin  
*Alain de Mijolla*  
*Translated by Robert Bononno*
- Freud, Josef  
*Alain de Mijolla*  
*Translated by Robert Bononno*
- Freud: Living and Dying*  
*Roy K. Lilleskov*
- Freud Museum  
*Michael Molnar*
- Freud-Nathanson, Amalia Malka  
*Alain de Mijolla*
- Freud, Oliver  
*Alain de Mijolla*  
*Translated by Robert Bononno*
- Freud, The Secret Passion*  
*Alain de Mijolla*  
*Translated by Gwendolyn Wells*
- Translated by John Galbraith Simmons and Jocelyne Barque*
- Freud’s Self-Analysis*  
*Sophie de Mijolla-Mellor*  
*Translated by Dan Collins*
- Freud, Sigmund (siblings)  
*Alain de Mijolla*  
*Translated by John Galbraith Simmons and Jocelyne Barque*
- Freud, Sigmund Schlomo  
*Alain de Mijolla*  
*Translated by Robert Bononno*
- Freund Toszeghy, Anton von  
*Michelle Moreau Ricaud*  
*Translated by Gwendolyn Wells*
- Friedländer-Fränk, Kate  
*Clifford Yorke*
- Friendship  
*Sophie de Mijolla-Mellor*  
*Translated by Robert Bononno*
- Fright  
*Claude Barrois*  
*Translated by Robert Bononno*
- Frink, Horace Westlake  
*Paul Roazen*
- “From the History of an Infantile Neurosis” (Wolf Man)  
*Patrick Mahony*
- Fromm, Erich  
*Paul Roazen*
- Fromm-Reichmann, Frieda  
*Ann-Louise S. Silver*
- Frustration  
*Luiz Eduardo Prado de Oliveira*  
*Translated by Sophie Leighton*
- Functional phenomenon  
*Alain de Mijolla*  
*Translated by Gwendolyn Wells*
- Fundamental rule  
*Jean-Luc Donnet*  
*Translated by Sophie Leighton*
- Fusion/defusion  
*Cléopâtre Athanassiou-Popesco*  
*Translated by Gwendolyn Wells*
- Fusion/defusion of instincts  
*Josette Frappier*  
*Translated by Donald Nicholson-Smith*
- Future of an Illusion, The*  
*Odon Vallet*  
*Translated by Robert Bononno*

**G**

Gaddini, Eugenio

*Anna Maria Accerboni**Translated by Robert Bononno*

Gain (primary and secondary)

*Dominique Blin**Translated by Liam Gavin*

Gardiner, Muriel M.

*Nellie L. Thompson*

Garma, Angel

*R. Horacio Etchegoyen**Translated by Robert Bononno*

Gattel, Felix

*Nicolas Gougoulis**Translated by Robert Bononno*

Geleerd, Elisabeth

*Nellie L. Thompson*

Gender identity

*Christopher Gelber*

General theory of seduction

*Jean Laplanche**Translated by Donald Nicholson-Smith*

Genital love

*Jean-François Rabain**Translated by Robert Bononno*

Genital stage

*Jean-François Rabain**Translated by Donald Nicholson-Smith*German romanticism and  
psychoanalysis*Madeleine Vermorel and**7Henri Vermorel**Translated by Gwendolyn Wells*

Germany

*Regine Lockot**Translated by Robert Bononno**Gesammelte Schriften**Ilse Grubrich-Simitis**Translated by Donald Nicholson-Smith**Gessammelte Werke**Ilse Grubrich-Simitis**Translated by Donald Nicholson-Smith*

Gestapo

*Alain de Mijolla**Translated by Robert Bononno*

Gift

*Dominique J. Arnoux**Translated by Robert Bononno*

Glover, Edward

*Clifford Yorke*

Glover, James

*Malcolm Pines*

Goethe and psychoanalysis

*Henri Vermorel**Translated by Robert Bononno*

Goethe Prize

*Thomas Plänklers**Translated by Robert Bononno*

Good-enough mother

*Jennifer Johns*

Göring, Matthias Heinrich

*Geoffrey Cocks*

Graf, Herbert

*Veronica Mächtlinger*

Graf, Max

*Elke Mühlleitner**Translated by Robert Bononno*

Grandiose self

*Agnès Oppenheimer**Translated by Gwendolyn Wells*

Granoff, Wladimir Alexandre

*Jacques Sédot**Translated by Robert Bononno*

Graph of Desire

*Bernard Penot**Translated by Dan Collins*

Great Britain

*Malcolm Pines*

Greece

*Anna Potamianou**Translated by Gwendolyn Wells*

Greenacre, Phyllis

*Nellie L. Thompson*

Greenson, Ralph

*Daniel Greenson*

Gressot, Michel

*Jean-Michel Quinodoz**Translated by Robert Bononno*

Grid

*Pedro Luzes**Translated by Gwendolyn Wells*

Groddeck, Georg Walther

*Herbert Will**Translated by Robert Bononno*

Gross, Otto Hans Adolf

*Alain de Mijolla**Translated by Robert Bononno*

Group analysis

*René Kaës**Translated by Gwendolyn Wells*

Group phenomenon

*Bernard Defontaine**Translated by Gwendolyn Wells**Group Psychology and the Analysis of  
the Ego**Michèle Porte**Translated by Gwendolyn Wells*

Group psychotherapies

*René Kaës**Translated by Gwendolyn Wells*

Guex, Germaine

*Jean-Michel Quinodoz**Translated by Gwendolyn Wells*

Guilbert, Yvette

*Jean-Pierre Bourgeron**Translated by John Galbraith Simmons  
and Jocelyne Barque*

Guilt, feeling of

*Léon Grinberg**Translated by John Galbraith Simmons  
and Jocelyne Barque*

Guilt, unconscious sense of

*Léon Grinberg**Translated by John Galbraith Simmons  
and Jocelyne Barque***H**

Halberstadt-Freud, Sophie

*Alain de Mijolla**Translated by Robert Bononno*

Hall, Granville Stanley

*Florian Houssier*

Hallucinatory, the

*César Botella and Sara Botella**Translated by Gwendolyn Wells*

Hallucinosi

*Edna O'Shaughnessy**Hamlet and Oedipus**François Sacco**Translated by Robert Bononno*

Hampstead Clinic

*Delphine Schilton**Translated by Donald Nicholson-Smith*

Handling

*Campbell Paul*

Happel, Clara

*Alain de Mijolla**Translated by John Galbraith Simmons  
and Jocelyne Barque*

Hard science and psychoanalysis

*Michèle Porte**Translated by Philip Beitchman*

Hartmann, Heinz

*Lawrence Hartmann*

- Hatred  
*Nicole Jeammet*  
*Translated by Gwendolyn Wells*
- Heimann, Paula  
*Margaret Tonnesmann*
- Held, René  
*Alain de Mijolla*  
*Translated by Robert Bononno*
- Heller, Hugo  
*Lydia Marinelli*  
*Translated by Liam Gavin*
- Hellman Noach, Ilse  
*Clifford Yorke*  
*Translated by Liam Gavin*
- Helplessness  
*Anne Aubert-Godard*  
*Translated by Gwendolyn Wells*
- “Heredity and the Etiology of the  
Neuroses”  
*Alain de Mijolla*  
*Translated by Liam Gavin*
- Heredity of acquired characters  
*Roger Perron*  
*Translated by Liam Gavin*
- Hermann, Imre  
*Hungarian Group*
- Hermeneutics  
*Dominique Auffret*  
*Translated by Robert Bononno*
- Heroic identification  
*Bernard Golse*  
*Translated by Gwendolyn Wells*
- Heroic self  
*Riccardo Steiner*
- Hesnard, Angéolo Louis Marie  
*Alain de Mijolla*  
*Translated by Robert Bononno*
- Heterosexuality  
*Bertrand Vichyn*  
*Translated by Liam Gavin*
- Heuyer, Georges  
*Jean-Louis Lang*  
*Translated by Robert Bononno*
- Hietzing Schule/Burlingham-Rosen-  
feld School  
*Alain de Mijolla*  
*Translated by John Galbraith Simmons*  
*and Jocelyne Barque*
- Hilferding-Hönigsberg, Margarethe  
*Elke Mühlleitner*  
*Translated by Robert Bononno*
- Hirschfeld, Elfriede  
*Nicolas Gougoulis*  
*Translated by Robert Bononno*
- Historical reality  
*René Roussillon*  
*Translated by Robert Bononno*
- Historical truth  
*Sophie de Mijolla-Mellor*  
*Translated by Gwendolyn Wells*
- History and psychoanalysis  
*Roger Perron*  
*Translated by Sophie Leighton*
- Hitschmann, Eduard  
*Harald Leupold-Löwenthal*  
*Translated by John Galbraith Simmons*  
*and Jocelyne Barque*
- Hoffer, Willi (Wilhelm)  
*Clifford Yorke*
- Hogarth Press  
*Clifford Yorke*
- Holding  
*Campbell Paul*
- Hollitscher-Freud, Mathilde  
*Alain de Mijolla*  
*Translated by John Galbraith Simmons*  
*and Jocelyne Barque*
- Hollós, István  
*Michelle Moreau Ricaud*  
*Translated by Liam Gavin*
- Homosexuality  
*Bertrand Vichyn*  
*Translated by Sophie Leighton*
- Horney-Danielson, Karen  
*Bernard Paris*
- Hospitalism  
*Léon Kreisler*  
*Translated by Gwendolyn Wells*
- Hug-Hellmuth-Hug von  
Hugenstein, Hermine  
*Elke Mühlleitner*  
*Translated by John Galbraith Simmons*  
*and Jocelyne Barque*
- Humor  
*Jean-Pierre Kamierniak*  
*Translated by Sophie Leighton*
- Hungarian School  
*Hungarian Group*
- Hungary  
*Éva Brabant-Gerö*  
*Translated by Robert Bononno*
- Hypercathexis  
*Richard Uhl*
- Translated by Donald Nicholson-Smith*
- Hypnoid states  
*Roger Perron*  
*Translated by Gwendolyn Wells*
- Hypnosis  
*Jacqueline Carroy*  
*Translated by Robert Bononno*
- Hypochondria  
*Alain Fine*  
*Translated by Gwendolyn Wells*
- Hypocritical dream  
*Roger Perron*  
*Translated by Dan Collins*
- Hysteria  
*Jacqueline Schaeffer*  
*Translated by Robert Bononno*
- Hysterical paralysis  
*Augustin Jeanneau*  
*Translated by Dan Collins*
- I**
- I  
*Sophie de Mijolla-Mellor*  
*Translated by Dan Collins*
- Id  
*Michèle Porte*  
*Translated by Donald Nicholson-Smith*
- Idea/representation  
*Roger Perron*  
*Translated by Robert Bononno*
- Idealization  
*Sophie de Mijolla-Mellor*  
*Translated by Dan Collins*
- Idealized parental imago  
*Agnès Oppenheimer*  
*Translated by Gwendolyn Wells*
- Idealizing transference  
*Agnès Oppenheimer*  
*Translated by Dan Collins*
- Ideational representation  
*Sophie de Mijolla-Mellor*  
*Translated by Gwendolyn Wells*
- Ideational representative  
*Roger Perron*  
*Translated by Gwendolyn Wells*
- Identification  
*Alain de Mijolla*  
*Translated by Robert Bononno*
- Identification fantasies  
*Alain de Mijolla*  
*Translated by Gwendolyn Wells*
- Identification with the aggressor

- Clifford Yorke*  
 Identificatory project  
*Sophie de Mijolla-Mellor*  
 Translated by *Gwendolyn Wells*
- Identity  
*Agnès Oppenheimer*  
 Translated by *Robert Bononno*
- Ideology  
*Dominique Auffret*  
 Translated by *Robert Bononno*
- Illusion  
*Sophie de Mijolla-Mellor*  
 Translated by *Robert Bononno*
- Imaginary identification/symbolic identification  
*Marc Darmon*  
 Translated by *Dan Collins*
- Imaginary, the (Lacan)  
*Marie-Christine Laznik*  
 Translated by *Dan Collins*
- Imago  
*Antoine Ducret*  
 Translated by *Gwendolyn Wells*
- Imago Publishing Company  
*Clifford Yorke*
- Imago. Zeitschrift für die Anwendung der Psychoanalyse auf die Geisteswissenschaften*  
*Lydia Marinelli*  
 Translated by *Robert Bononno*
- Imposter  
*Andrée Bauduin*  
 Translated by *Robert Bononno*
- Incest  
*Roger Perron*  
 Translated by *John Galbraith Simmons and Jocelyne Barque*
- Incompleteness  
*René Pérán*  
 Translated by *Gwendolyn Wells*
- Inconscient, L'*  
*Alain de Mijolla*  
 Translated by *Robert Bononno*
- India  
*Sudhir Kakar*
- Indications and contraindications for psychoanalysis for an adult  
*Alain de Mijolla*  
 Translated by *Sophie Leighton*
- Individual  
*Henri Vermorel*
- Translated by *Robert Bononno*
- Individuation (analytical psychology)  
*Christian Gaillard*  
 Translated by *Sophie Leighton*
- Infans  
*Sophie de Mijolla-Mellor*  
 Translated by *Gwendolyn Wells*
- Infant development  
*Monique Piñol-Douriez and Maurice Despinoy*  
 Translated by *Gwendolyn Wells*
- Infant observation  
*Robert D. Hinshelwood*
- Infant observation (direct)  
*Drina Candilis-Huisman*  
 Translated by *Gwendolyn Wells*
- Infant observation (therapeutic)  
*Christine Anzieu-Premereur*  
 Translated by *Gwendolyn Wells*
- Infantile amnesia  
*François Richard*  
 Translated by *Dan Collins*
- Infantile neurosis  
*Serge Lebovici*  
 Translated by *Sophie Leighton*
- Infantile omnipotence  
*Sophie de Mijolla-Mellor*  
 Translated by *John Galbraith Simmons and Jocelyne Barque*
- Infantile psychosis  
*Bernard Touati*  
 Translated by *Sophie Leighton*
- Infantile schizophrenia  
*Serge Lebovici*  
 Translated by *Gwendolyn Wells*
- Infantile sexual curiosity  
*Sophie de Mijolla-Mellor*  
 Translated by *Dan Collins*
- Infantile, the  
*Cléopâtre Athanassiou-Popesco*  
 Translated by *Gwendolyn Wells*
- Inferiority, feeling of  
*Roger Perron*  
 Translated by *Gwendolyn Wells*
- Inferiority, feeling of (individual psychology)  
*François Compan*  
 Translated by *Liam Gavin*
- Inhibition  
*Nicolas Dissez*  
 Translated by *Liam Gavin*
- Inhibitions, Symptoms, and Anxiety*  
*Bernard Golse*  
 Translated by *Robert Bononno*
- Initial interview(s)  
*Alain de Mijolla*  
 Translated by *Gwendolyn Wells*
- Innervation  
*Bertrand Vichyn*  
 Translated by *Liam Gavin*
- Insight  
*Roger Perron*  
 Translated by *Robert Bononno*
- Instinct  
*Claude Smadja*  
 Translated by *Dan Collins*
- “Instincts and their Vicissitudes”  
*Michèle Porte*  
 Translated by *Dan Collins*
- Instinctual impulse  
*Michèle Porte*  
 Translated by *Gwendolyn Wells*
- Instinctual representative  
*Roger Perron*  
 Translated by *Dan Collins*
- Institut Claparède  
*Simone Decobert*  
 Translated by *Robert Bononno*
- Institut Max-Kassowitz  
*Carlo Bonomi*  
 Translated by *Robert Bononno*
- Integration  
*Bernard Golse*  
 Translated by *Gwendolyn Wells*
- Intellectualization  
*Sophie de Mijolla-Mellor*  
 Translated by *Liam Gavin*
- Intergenerational  
*Haydée Faimberg*  
 Translated by *Gwendolyn Wells*
- Internal object  
*Marie Eugénie Jullian Muzzo Benavides*  
 Translated by *John Galbraith Simmons and Jocelyne Barque*
- Internal/external reality  
*Jean-Pierre Chartier*  
 Translated by *Gwendolyn Wells*
- International Association for the History of Psychoanalysis  
*Alain de Mijolla*  
 Translated by *Robert Bononno*



- International Federation of  
Psychoanalytic Societies  
*Carlo Bonomi*  
*Translated by Liam Gavin*
- International Journal of  
Psychoanalysis, The*  
*Riccardo Steiner*
- International Psychoanalytical  
Association  
*Robert S. Wallerstein*
- Internationale Zeitschrift für  
(ärztliche) Psychoanalyse*  
*Lydia Marinelli*  
*Translated by Liam Gavin*
- Internationaler Psychoanalytischer Verlag  
*Lydia Marinelli*  
*Translated by Robert Bononno*
- Interpretation  
*Jacques Angelergues*  
*Translated by Sophie Leighton*
- Interprétation*  
*Josette Garon*  
*Translated by Sophie Leighton*
- Interpretation of dreams (analytical  
psychology)  
*Thomas B. Kirsch*
- Interpretation of Dreams, The*  
*Roger Perron*  
*Translated by Robert Bononno*
- Intersubjective/intrasubjective  
*Bernard Golse*  
*Translated by Gwendolyn Wells*
- Introductory Lectures on  
Psychoanalysis*  
*Sophie de Mijolla-Mellor*  
*Translated by Robert Bononno*
- Introjection  
*Pierre Sabourin*  
*Translated by Gwendolyn Wells*
- “Introjection and Transference”  
*Pierre Sabourin*  
*Translated by Gwendolyn Wells*
- Introspection  
*Roger Perron*  
*Translated by Liam Gavin*
- Invariant  
*Jean-Claude Guillaume*  
*Translated by Gwendolyn Wells*
- Irma’s injection, dream of  
*Roger Perron*  
*Translated by Robert Bononno*
- Isaacs-Sutherland, Susan  
*Riccardo Steiner*
- Isakower phenomenon  
*Bernard Golse*  
*Translated by Liam Gavin*
- Isakower, Otto  
*Alain de Mijolla*  
*Translated by John Galbraith Simmons  
and Jocelyne Barque*
- Isolation  
*Elsa Schmid-Kitsikis*  
*Translated by John Galbraith Simmons  
and Jocelyne Barque*
- Israel  
*Yolanda Gampel*
- Italy  
*Rosario Merendino*  
*Translated by Robert Bononno*
- J**
- Jacobson, Edith  
*Nellie L. Thompson*
- Jahrbuch der Psychoanalyse*  
*Lydia Marinelli*  
*Translated by Liam Gavin*
- Jalousie amoureuse, La*  
*Régine Prat*  
*Translated by Liam Gavin*
- Janet, Pierre  
*Annick Ohayon*  
*Translated by Robert Bononno*
- Jankélévitch, Samuel  
*Annick Ohayon*  
*Translated by Robert Bononno*
- Japan  
*Keigo Okonogi*
- Jekels (Jekeles), Ludwig  
*Harald Leupold-Löwenthal*  
*Translated by Robert Bononno*
- Jelliffe, Smith Ely  
*Alain de Mijolla*  
*Translated by Robert Bononno*
- Jokes  
*Sophie de Mijolla-Mellor*  
*Translated by Robert Bononno*
- Jokes and their Relation to the  
Unconscious*  
*Sophie de Mijolla-Mellor*  
*Translated by Robert Bononno*
- Jones, Ernest  
*Riccardo Steiner*
- Jouissance (Lacan)  
*Marie-Christine Laznik*  
*Translated by Dan Collins*
- Journal de la psychanalyse de l’enfant*  
*Jean-Claude Guillaume*  
*Translated by Liam Gavin*
- Journal d’un médecin malade*  
*Marguerite Frémont*  
*Translated by Robert Bononno*
- Journal of the American Psychoanaly-  
tic Association*  
*Arnold D. Richards*
- Jouve, Pierre Jean  
*Jean-Pierre Bourgeron*  
*Translated by Robert Bononno*
- Judaism and psychoanalysis  
*Jacques Ascher and Pèrel Wilgowicz*  
*Translated by Liam Gavin*
- Judgment of condemnation  
*Sophie de Mijolla-Mellor*  
*Translated by Gwendolyn Wells*
- Jung, Carl Gustav  
*Thomas B. Kirsch*
- Jung-Rauschenbach, Emma  
*Brigitte Allain-Dupré*  
*Translated by Liam Gavin*
- Jury, Paul  
*André Michel*  
*Translated by Robert Bononno*
- K**
- Kantianism and psychoanalysis  
*Bernard Lemaigre*  
*Translated by Robert Bononno*
- Kardiner, Abram  
*Ethel S. Person*
- Katan, Maurits  
*Robert A. Furman*
- Katan-Rosenberg, Anny  
*Robert A. Furman*
- Katharina, case of  
*Alain de Mijolla*  
*Translated by Robert Bononno*
- Kemper, Werner Walther  
*René Péran*  
*Translated by Liam Gavin*
- Kestenberg, Jean  
*Liliane Abensour*  
*Translated by Liam Gavin*
- Kestenberg-Hassin, Evelyne  
*Liliane Abensour*

- Translated by Gwendolyn Wells*  
 Khan, Mohammed Masud Rasa  
*Bernard Golse*  
*Translated by Robert Bononno*
- Klein-Reizes, Melanie  
*Robert D. Hinshelwood*
- Klinische Studie über die halbseitiger Cerebrallähmung der Kinder*  
 [Clinical study of infantile cerebral diplegia]  
*Johann Georg Reicheneder*  
*Translated by Gwendolyn Wells*
- Knot  
*Henri Cesbron Lavau*  
*Translated by Gwendolyn Wells*
- Knowledge or research, instinct for  
*Sophie de Mijolla-Mellor*  
*Translated by Gwendolyn Wells*
- Koch, Adelheid Lucy  
*Leopold Nosek*  
*Translated by John Galbraith Simmons and Jocelyne Barque*
- Kohut, Heinz  
*Agnès Oppenheimer*  
*Translated by Robert Bononno*
- Korea  
*Geoffrey H. Blowers*
- Kosawa, Heisaku  
*Keigo Okonogi*
- Kouretas, Démétrios  
*Anna Potamianou*  
*Translated by Liam Gavin*
- Kovács-Prosznitz, Vilma  
*Judith Dupont*  
*Translated by Liam Gavin*
- Kraus, Karl  
*Erik Porge*  
*Translated by Robert Bononno*
- Kris, Ernst  
*Elke Mühllleitner*  
*Translated by Robert Bononno*
- Kris-Rie, Marianne  
*Ernst Federn*  
*Translated by Liam Gavin*
- L**
- L and R schemas  
*Patrick Delaroche*  
*Translated by Dan Collins*
- Lacan, Jacques-Marie Émile  
*Jacques Sédat*  
*Translated by Dan Collins*
- Lack of differentiation  
*Bernard Golse*  
*Translated by Gwendolyn Wells*
- Laforgue, René  
*Jean-Pierre Bourgeron*  
*Translated by Robert Bononno*
- Lagache, Daniel  
*Eva Rosenblum*  
*Translated by John Galbraith Simmons and Jocelyne Barque*
- Lainé, Tony  
*Patrice Huerre*  
*Translated by Liam Gavin*
- Laing, Ronald David  
*James R. Hood*
- Lampl, Hans  
*Elke Mühllleitner*  
*Translated by Liam Gavin*
- Lampl-de Groot, Jeanne  
*Elizabeth Verhage-Stins*
- Landauer, Karl  
*Hans-Joachim Rothe*  
*Translated by John Galbraith Simmons and Jocelyne Barque*
- Langer, Marie Glass Hauser de  
*Janine Puget*  
*Translated by Liam Gavin*
- Language and disturbances of language  
*Georges Lantéri-Laura*  
*Translated by Donald Nicholson-Smith*
- Language of Psychoanalysis, The*  
*Jean-Louis Brenot*  
*Translated by Donald Nicholson-Smith*
- Lanzer, Ernst  
*Patrick Mahony*
- Latency period  
*Rodolfo Urribarri*  
*Translated by Sophie Leighton*
- Latent  
*André Missenard*  
*Translated by Sophie Leighton*
- Latent dream thoughts  
*Roger Perron*  
*Translated by Sophie Leighton*
- Laurent-Lucas-Championnière-Maugé, Odette  
*Jean-Pierre Bourgeron*  
*Translated by Liam Gavin*
- Law and psychoanalysis  
*Marie-Dominique Trapet*  
*Translated by Robert Bononno*
- Law of the father  
*Patrick De Neuter*  
*Translated by Robert Bononno*
- Lay analysis  
*Roger Perron*  
*Translated by Dan Collins*
- Le Bon, Gustave  
*Annick Ohayon*  
*Translated by Robert Bononno*
- Learning from Experience*  
*James S. Grotstein*
- Lebovici, Serge Sindel Charles  
*Alain de Mijolla*  
*Translated by Robert Bononno*
- Lechat, Fernand  
*Daniel Luminet*  
*Translated by Liam Gavin*
- Leclaire (Liebschutz), Serge  
*Jacques Sédat*  
*Translated by Dan Collins*
- Leeuw, Pieter Jacob Van der  
*Elizabeth Verhage-Stins*
- Lehrinstitut der Wiener psychoanalytischen Vereinigung  
*Eva Laible*  
*Translated by Liam Gavin*
- Lehrman, Philip R.  
*Michelle Moreau Ricaud*  
*Translated by Liam Gavin*
- Leonardo da Vinci and a Memory of his Childhood*  
*Sophie de Mijolla-Mellor*  
*Translated by Robert Bononno*
- Letter, the  
*Jean-Paul Hilttenbrand*  
*Translated by Robert Bononno*
- Leuba, John  
*Jean-Pierre Bourgeron*  
*Translated by Gwendolyn Wells*
- Levi Bianchini, Marco  
*Anna Maria Accerboni*  
*Translated by Robert Bononno*
- Lieberman, David  
*Gilda Sabsay Foks*  
*Translated by Liam Gavin*
- Libidinal development  
*Michèle Pollak Cornillot*  
*Translated by Liam Gavin*

- Libidinal stage  
*Jean-François Rabain*  
Translated by Donald Nicholson-Smith
- Libido  
*Alain de Mijolla*  
Translated by Sophie Leighton
- Lie  
*Sophie de Mijolla-Mellor*  
Translated by Gwendolyn Wells
- Liebeault, Ambroise Auguste  
*Jacqueline Carroy*  
Translated by Liam Gavin
- Life and Work of Sigmund Freud*  
*Riccardo Steiner*
- Life and Works of Edgar Allen Poe: A  
Psychoanalytic Interpretation*  
*Anne-Marie Mairesse*  
Translated by Robert Bononno
- Life instinct (Eros)  
*Isaac Salem*  
Translated by Donald Nicholson-Smith
- Lifting of amnesia  
*François Richard*  
Translated by Philip Beitchman
- Limentani, Adam  
*Moses Laufer*
- “Lines of Advance in Psycho-Analytic  
Therapy”  
*Alain de Mijolla*  
Translated by Donald Nicholson-Smith
- Lingüística, Interacción  
comunicativa y Proceso  
psicoanalítico*  
*David Rosenfeld*  
Translated by Liam Gavin
- Linguistics and psychoanalysis  
*Anne-Marie Houdebine*  
Translated by Robert Bononno
- Linking, attacks on  
*Edna O’Shaughnessy*
- Listening  
*Marie-France Castarède*  
Translated by Liam Gavin
- Literary and artistic creation  
*Sophie de Mijolla-Mellor*  
Translated by Robert Bononno
- Literature and psychoanalysis  
*Anne Roche*  
Translated by Robert Bononno
- Little Arpåd, the boy pecked by a cock  
*Pierre Sabourin*
- Translated by Liam Gavin
- Loewenstein, Rudolph M.  
*Michelle Moreau Ricaud*  
Translated by Gwendolyn Wells
- Logic(s)  
*Sophie de Mijolla-Mellor*  
Translated by Gwendolyn Wells
- Look/gaze  
*Jean-Michel Hirtt*  
Translated by Dan Collins
- Lorand, Sándor  
*Michelle Moreau Ricaud*  
Translated by Liam Gavin
- Los Angeles Psychoanalytic Societies  
and Institutes  
*John Galbraith Simmons*
- Lost object  
*Jacques Sédat*  
Translated by Gwendolyn Wells
- Love  
*Jacques Sédat*  
Translated by Robert Bononno
- Love-Hate-Knowledge (L/H/K links)  
*Bernard Golse*  
Translated by Philip Beitchman
- Low, Barbara  
*Clifford Yorke*
- Lucy R., case of  
*Alain de Mijolla*  
Translated by Robert Bononno
- M**
- Maeder, Alphonse E.  
*Kaspar Weber*  
Translated by Liam Gavin
- Magical thinking  
*Sophie de Mijolla-Mellor*  
Translated by Robert Bononno
- Mahler, Gustav (meeting with  
Sigmund Freud)  
*Dominique Blin*  
Translated by Robert Bononno
- Mahler-Schönberger, Margaret  
*Philippe Mazet*  
Translated by John Galbraith Simmons  
and Jocelyne Barque
- Main, Thomas Forrest  
*Malcolm Pines*
- Mâle, Pierre  
*Pierre Bourdier*  
Translated by Gwendolyn Wells
- Malinowski, Bronislaw Kaspar  
*Bertrand Pulman*  
Translated by Robert Bononno
- Mania  
*Alban Jeanneau*  
Translated by Gwendolyn Wells
- Manic defenses  
*Elsa Schmid-Kitsikis*  
Translated by Philip Beitchman
- Manifest  
*André Missenard*  
Translated by Gwendolyn Wells
- Mann, Thomas  
*Didier David*  
Translated by Robert Bononno
- Mannoni, Dominique-Octave  
*Jacques Sédat*  
Translated by John Galbraith Simmons  
and Jocelyne Barque
- Mannoni-Van der Spoel, Maud  
(Magdalena)  
*Jacques Sédat*  
Translated by John Galbraith Simmons  
and Jocelyne Barque
- Marcinowski, Johannes (Jaroslaw)  
*Elke Mühlleitner*  
Translated by Liam Gavin
- Marcondes, Durval Bellegarde  
*Fabio Herrmann and Roberto Yutaka  
Sagawa*  
Translated by Liam Gavin
- Marcuse, Herbert  
*Roger Dadoun*  
Translated by Robert Bononno
- Martinique  
*Guillaume Suréna*  
Translated by Liam Gavin
- Martins, Cyro  
*Germano Vollmer Filho*
- Marty, Pierre  
*Rosine Debray*  
Translated by Robert Bononno
- Marxism and psychoanalysis  
*Michèle Bertrand*  
Translated by Dan Collins
- Masculine protest (individual  
psychology)  
*François Compan*  
Translated by Liam Gavin
- Masculinity/femininity  
*Philippe Metello*  
Translated by Robert Bononno
- Masochism  
*Denys Ribas*

- Translated by Robert Bononno*  
*Mass Psychology of Fascism, The*  
*Roger Dadoun*  
*Translated by Donald Nicholson-Smith*
- Mastery**  
*Marc Bonnet*  
*Translated by Gwendolyn Wells*
- Mastery, instinct for**  
*Paul Denis*  
*Translated by Gwendolyn Wells*
- Masturbation**  
*Franck Zigante*  
*Translated by Dan Collins*
- Maternal**  
*Anne Aubert-Godard*  
*Translated by Robert Bononno*
- Maternal care**  
*Yvon Gauthier*  
*Translated by Donald Nicholson-Smith*
- Maternal reverie, capacity for**  
*Bernard Golse*  
*Translated by Gwendolyn Wells*
- Matheme**  
*Henri Cesbron Lavau*  
*Translated by Dan Collins*
- Mathilde, case of**  
*Albrecht Hirschmüller*  
*Translated by Robert Bononno*
- Matte-Blanco, Ignacio**  
*Jorge L. Ahumada*
- Maturation**  
*Roger Perron*  
*Translated by Liam Gavin*
- Mauco, Georges**  
*Jean-Pierre Bourgeron*  
*Translated by Liam Gavin*
- Mead, Margaret**  
*Bertrand Pulman*  
*Translated by Robert Bononno*
- Megalomania**  
*Marc Bonnet*  
*Translated by Gwendolyn Wells*
- Melancholia**  
*Alban Jeanneau*  
*Translated by Robert Bononno*
- Melancholic depression**  
*Francisco Palacio Espasa*  
*Translated by Gwendolyn Wells*
- Memoirs of the future**  
*James S. Grotstein*
- Memories**  
*François Richard*  
*Translated by Robert Bononno*
- Memory**  
*Yvon Brès*  
*Translated by Robert Bononno*
- Meng, Heinrich**  
*Thomas Plänklers*  
*Translated by Liam Gavin*
- Menninger Clinic**  
*Glen O. Gabbard*
- Menninger, Karl A.**  
*Glen O. Gabbard*
- Mentalization**  
*Alain Fine*  
*Translated by Gwendolyn Wells*
- Merleau-Ponty, Maurice**  
*Georges Lantéri-Laura*  
*Translated by Robert Bononno*
- Metaphor**  
*Joël Dor*  
*Translated by Dan Collins*
- “Metapsychological Supplement to the Theory of Dreams”**  
*Alain de Mijolla*  
*Translated by Sophie Leighton*
- Metapsychology**  
*René Roussillon*  
*Translated by Robert Bononno*
- Metonymy**  
*Joël Dor*  
*Translated by Dan Collins*
- Mexico**  
*Luis Féder*
- Meyer, Adolf F.**  
*Elke Mühlleitner*  
*Translated by John Galbraith Simmons and Jocelyne Barque*
- Meyerson, Ignace**  
*Annick Ohayon*  
*Translated by Liam Gavin*
- Meynert, Theodor**  
*Eva Laible*  
*Translated by Liam Gavin*
- Midlife crisis**  
*Bernard Golse*  
*Translated by Liam Gavin*
- Minkowska-Brokman, Françoise**  
*Jean Garrabé*  
*Translated by Liam Gavin*
- Minkowski, Eugène**
- Jean Garrabé*  
*Translated by Robert Bononno*
- Minutes of the Vienna Psychoanalytic Society**  
*Ernst Federn*  
*Translated by Gwendolyn Wells*
- Mirror stage**  
*Marie-Christine Laznik*  
*Translated by Donald Nicholson-Smith*
- Mirror transference**  
*Agnès Oppenheimer*  
*Translated by Gwendolyn Wells*
- Mitscherlich, Alexander**  
*Hans-Martin Lohmann*  
*Translated by John Galbraith Simmons and Jocelyne Barque*
- Mnemonic symbol**  
*François Richard*  
*Translated by Dan Collins*
- Mnemonic trace/memory trace**  
*François Richard*  
*Translated by Dan Collins*
- Modern conflict theory**  
*Charles Brenner*
- Modesty**  
*Jean-Jacques Rassial*  
*Translated by Gwendolyn Wells*
- Mom, Jorge Mario**  
*Gilda Sabsay Foks*  
*Translated by Liam Gavin*
- Money and psychoanalytic treatment**  
*Ghyslain Levy*  
*Translated by Robert Bononno*
- Money-Kyrle, Roger Earle**  
*Riccardo Steiner*
- Monism**  
*Michèle Porte*  
*Translated by Gwendolyn Wells*
- Moral masochism**  
*Denys Ribas*  
*Translated by Gwendolyn Wells*
- Moreno, Jacob Levy**  
*Nadine Amar*  
*Translated by Liam Gavin*
- Morgenstern-Kabatschnik, Sophie**  
*Frédérique Jacquemain*  
*Translated by Liam Gavin*
- Morgenthaler, Fritz**  
*Kaspar Weber*  
*Translated by Liam Gavin*
- Morichau-Beauchant, Pierre Ernest René**

- Michelle Moreau Ricaud*  
*Translated by Liam Gavin*
- Morselli, Enrico  
*Giancarlo Gramaglia*  
*Translated by Liam Gavin*
- Moser-van Sulzer-Wart, Fanny  
Louise  
*Alain de Mijolla*  
*Translated by Liam Gavin*
- Moses and Monotheism*  
*Pierre Ferrari*  
*Translated by Robert Bononno*
- “Moses of Michelangelo, The”  
*Brigitte Lemérar*  
*Translated by Robert Bononno*
- Mother goddess  
*Odon Vallet*  
*Translated by Robert Bononno*
- Mourning  
*Benjamin Jacobi*  
*Translated by Dan Collins*
- “Mourning and Melancholia”  
*Sophie de Mijolla-Mellor*  
*Translated by Robert Bononno*
- Mourning, dream of  
*Roger Perron*  
*Translated by Gwendolyn Wells*
- Mouvement lacanien français  
*Jacques Sédat*  
*Translated by Dan Collins*
- Müller-Braunschweig, Carl  
*Regine Lockot*  
*Translated by Liam Gavin*
- Multilingualism and psychoanalysis  
*Juan-Eduardo Tesone*  
*Translated by Robert Bononno*
- Murray, Henry A.  
*Paul Roazen*
- Musatti, Cesare  
*Giancarlo Gramaglia*  
*Translated by Liam Gavin*
- Music and psychoanalysis  
*Marie-France Castarède*  
*Translated by Gwendolyn Wells*
- Mutative interpretation  
*Jacques Angelergues*  
*Translated by Gwendolyn Wells*
- Mutual analysis  
*Pierre Sabourin*  
*Translated by Dan Collins*
- Mysticism
- Odon Vallet*  
*Translated by Robert Bononno*
- Myth of origins  
*Julia Kristeva*  
*Translated by Gwendolyn Wells*
- Myth of the Birth of the Hero, The*  
*René Kaës*  
*Translated by Andrew Brown*
- Myth of the hero  
*René Kaës*  
*Translated by Robert Bononno*
- Mythology and psychoanalysis  
*Nicos Nicolaïdis*  
*Translated by Robert Bononno*
- Mythomania  
*Bernard Golse*  
*Translated by Gwendolyn Wells*
- Myths  
*Nicole Belmont*  
*Translated by Liam Gavin*
- N**
- Nacht, Sacha Emanoel  
*Alain de Mijolla*  
*Translated by Liam Gavin*
- Nakedess, dream of  
*Roger Perron*  
*Translated by Gwendolyn Wells*
- Name-of-the-Father  
*Charles Melman*  
*Translated by Gwendolyn Wells*
- Narcissism  
*Michel Vincent*  
*Translated by Robert Bononno*
- Narcissism of minor differences  
*Alain de Mijolla*  
*Translated by Liam Gavin*
- Narcissism, primary  
*Michel Vincent*  
*Translated by Donald Nicholson-Smith*
- Narcissism, secondary  
*Michel Vincent*  
*Translated by Philip Beitchman*
- Narcissistic defenses  
*Elsa Schmid-Kitsikis*  
*Translated by Philip Beitchman*
- Narcissistic elation  
*Marie-France Castarède*  
*Translated by Gwendolyn Wells*
- Narcissistic injury  
*Panos Alopis*  
*Translated by Philip Beitchman*
- Narcissistic neurosis  
*Michel Vincent*  
*Translated by Donald Nicholson-Smith*
- Narcissistic rage  
*Agnès Oppenheimer*  
*Translated by John Galbraith Simmons*  
*and Jocelyne Barque*
- Narcissistic transference  
*Paul Denis*  
*Translated by Donald Nicholson-Smith*
- Narcissistic withdrawal  
*Martine Myquel*  
*Translated by Gwendolyn Wells*
- Narco-analysis  
*Vassilis Kapsambelis*  
*Translated by Liam Gavin*
- National Psychological Association  
for Psychoanalysis  
*Gerald J. Gargiulo*
- Need for causality  
*Sophie de Mijolla-Mellor*  
*Translated by Dan Collins*
- Need for punishment  
*Léon Grinberg*  
*Translated by Dan Collins*
- Negation  
*Laurent Danon-Boileau*  
*Translated by Donald Nicholson-Smith*
- “Negation”  
*Monique Schneider*  
*Translated by Gwendolyn Wells*
- Negative capability  
*James S. Grotstein*
- Negative hallucination  
*François Duparc*  
*Translated by Gwendolyn Wells*
- Negative therapeutic reaction  
*Jean-François Rabain*  
*Translated by Dan Collins*
- Negative transference  
*Paul Denis*  
*Translated by Donald Nicholson-Smith*
- Negative, work of  
*André Green*  
*Translated by Robert Bononno*
- Neopsychoanalysis  
*Irma Gleiss*  
*Translated by Gwendolyn Wells*
- Nervous Anxiety States and their Treatment*  
*Francis Clark-Lowes*

- Netherlands  
*Han Groen-Prakken*
- Neurasthenia  
*Georges Lantéri-Laura*  
*Translated by Gwendolyn Wells*
- “Neurasthenia and ‘Anxiety  
Neurosis’”  
*Alain de Mijolla*  
*Translated by Gwendolyn Wells*
- Neuro-psychosis of defense  
*Elsa Schmid-Kitsikis*  
*Translated by Gwendolyn Wells*
- Neurosis  
*Francis Drossart*  
*Translated by Donald Nicholson-Smith*
- Neurosis and Human Growth*  
*Bernard Paris*
- Neurotic defenses  
*Elsa Schmid-Kitsikis*  
*Translated by Dan Collins*
- Neurotica  
*Didier Anzieu*  
*Translated by Robert Bononno*
- Neutrality/benevolent neutrality  
*Alain de Mijolla*  
*Translated by Liam Gavin*
- New Introductory Lectures on  
Psychoanalysis*  
*Alain de Mijolla*  
*Translated by Gwendolyn Wells*
- New York Freudian Society  
*Joseph Reppen*
- New York Psychoanalytic Institute  
*Manuel Furer*
- Night terrors  
*Philippe Metello*  
*Translated by Gwendolyn Wells*
- Nightmare  
*Philippe Metello*  
*Translated by Robert Bononno*
- Nin, Anaïs  
*Gunther Stuhlmann*
- Nirvana  
*Clifford Yorke*
- Nodet, Charles-Henri  
*Marcel Houser*  
*Translated by Robert Bononno*
- Nonverbal communication  
*Bernard Golse*  
*Translated by Robert Bononno*
- North African countries  
*Jalil Bennani*  
*Translated by Liam Gavin*
- Norway  
*Sverre Varvin*
- Nostalgia  
*André Bolzinger*  
*Translated by Robert Bononno*
- “Note upon the ‘Mystic Writing Pad,’  
A”  
*Dominique Auffret*  
*Translated by Robert Bononno*
- “Notes upon a Case of Obsessional  
Neurosis” (Rat Man)  
*Patrick Mahony*
- Nouvelle Revue de psychanalyse*  
*Edmundo Gomez Mango*  
*Translated by Gwendolyn Wells*
- Nuclear complex  
*Roger Perron*  
*Translated by Dan Collins*
- Numinous (analytical psychology)  
*Aimé Agnel*  
*Translated by Gwendolyn Wells*
- Nunberg, Hermann  
*Harald Leupold-Löwenthal*  
*Translated by John Galbraith Simmons  
and Jocelyne Barque*
- O**
- Oberholzer, Emil  
*Kaspar Weber*  
*Translated by Robert Bononno*
- Object  
*Nora Kurts*  
*Translated by Dan Collins*
- Object *a*  
*Valentin Nusinovič*  
*Translated by Dan Collins*
- Object relations theory  
*Otto F. Kernberg*
- Object, change of/choice of  
*Maité Klahr and Claudie Millot*  
*Translated by Gwendolyn Wells*
- Obsession  
*Marc Hayat*  
*Translated by Robert Bononno*
- Obsessional neurosis  
*Marc Hayat*  
*Translated by Dan Collins*
- Occultism  
*Odon Vallet*
- Translated by Robert Bononno*
- Oceanic feeling  
*Henri Vermorel and Madeleine Vermorel*  
*Translated by Gwendolyn Wells*
- Odier, Charles  
*Jean-Michel Quinodoz*  
*Translated by Liam Gavin*
- Oedipus complex  
*Roger Perron*  
*Translated by Donald Nicholson-Smith*
- Oedipus complex, early  
*Robert D. Hinshelwood*
- Omnipotence of thoughts  
*Sophie de Mijolla-Mellor*  
*Translated by John Galbraith Simmons  
and Jocelyne Barque*
- “On Dreams”  
*Roger Perron*  
*Translated by Dan Collins*
- “On Narcissism: An Introduction”  
*Alain de Mijolla*  
*Translated by Gwendolyn Wells*
- “On the History of the Psychoanalytic  
Movement”  
*Alain de Mijolla*  
*Translated by Robert Bononno*
- “On the Origin of the ‘Influencing  
Machine’ in Schizophrenia”  
*Marie-Thérèse Neyraut-Sutterman*  
*Translated by Donald Nicholson-Smith*
- “On the Sexual Theories of Children”  
*Sophie de Mijolla-Mellor*  
*Translated by Donald Nicholson-  
Smith*
- “On Transience”  
*Sophie de Mijolla-Mellor*  
*Translated by Robert Bononno*
- Ontogenesis  
*Jean-François Rabain*  
*Translated by Gwendolyn Wells*
- Operational thinking  
*Alain Fine*  
*Translated by Gwendolyn Wells*
- Opere* (Writings of Sigmund Freud)  
*Giancarlo Gramaglia*  
*Translated by Robert Bononno*
- Ophuijsen, Johan H. W. Van  
*Han Groen-Prakken*  
*Translated by Liam Gavin*
- Optical schema  
*Marie-Christine Laznik*

*Translated by Dan Collins*

**Orality**

*Dominique J. Arnoux*

*Translated by Gwendolyn Wells*

**Oral-sadistic stage**

*Jean-François Rabain*

*Translated by Donald Nicholson-Smith*

**Oral stage**

*Jean-François Rabain*

*Translated by Donald Nicholson-Smith*

**Organ pleasure**

*Claude Smadja*

*Translated by Philip Beitchman*

**Organic psychoses**

*Vassilis Kapsambelis*

*Translated by Gwendolyn Wells*

**Organic repression**

*Jean-François Rabain*

*Translated by Philip Beitchman*

**Organization**

*Claude Smadja*

*Translated by Liam Gavin*

**Orgasm**

*Sophie de Mijolla-Mellor*

*Translated by Robert Bononno*

**Orgone**

*Roger Dadoun*

*Translated by John Galbraith Simmons  
and Jocelyne Barque*

**Ornicar?**

*Jacques Sédat*

*Translated by Dan Collins*

**OSSIPOV, Nikolai Legrafovitch**

*Eugenie Fischer and René Fischer*

*Translated by Liam Gavin*

**Other, the**

*Charles Melman*

*Translated by Dan Collins*

**Otherness**

*Yvon Brès*

*Translated by Robert Bononno*

**Outline of Psychoanalysis, An**

*Christian Seulin*

*Translated by Robert Bononno*

**Overdetermination**

*Mathieu Zannotti*

*Translated by Donald Nicholson-Smith*

**Over-interpretation**

*Delphine Schilton*

*Translated by Dan Collins*

**P**

**Pain**

*Drina Candilis-Huisman*

*Translated by Gwendolyn Wells*

**Pair of opposites**

*Roger Perron*

*Translated by Dan Collins*

**Pankejeff, Sergueï**

*Patrick Mahony*

**Pankow, Gisela**

*Marie-Lise Lacas*

*Translated by Robert Bononno*

**Pappenheim, Bertha**

*Alain de Mijolla*

*Translated by John Galbraith Simmons  
and Jocelyne Barque*

**Parade of signifiers**

*Joël Dor*

*Translated by Dan Collins*

**Paradox**

*Jean-Pierre Caillot*

*Translated by Robert Bononno*

**Paranoia**

*Harold P. Blum*

**Paranoia (Freudian formulas of)**

*Luiz Eduardo Prado de Oliveira*

*Translated by Sophie Leighton*

**Paranoid position**

*Robert D. Hinshelwood*

**Paranoid psychosis**

*Bernard Touati*

*Translated by Philip Beitchman*

**Paranoid-schizoid position**

*Robert D. Hinshelwood*

**Paraphrenia**

*Nicolas Gougoulis*

*Translated by Dan Collins*

**Parapraxis**

*Sophie de Mijolla-Mellor*

*Translated by John Galbraith Simmons  
and Jocelyne Barque*

**Parcheminey, Georges**

*Jean-Pierre Bourgeron*

*Translated by Liam Gavin*

**Parenthood**

*Geneviève Delaisi de Parseval*

*Translated by Gwendolyn Wells*

**Parricide**

*Marie-Dominique Trapet*

*Translated by Robert Bononno*

**Partial drive**

*Michèle Porte*

*Translated by Dan Collins*

**Pasche, Francis Léopold Philippe**

*Michèle Bertrand*

*Translated by Liam Gavin*

**Pass, the**

*Jacques Sédat*

*Translated by Dan Collins*

**Passion**

*Sophie de Mijolla-Mellor*

*Translated by Robert Bononno*

**Payne, Sylvia May**

*Pearl H. M. King*

**Penis envy**

*Colette Chiland*

*Translated by Liam Gavin*

**Peraldi, François**

*Jacques Vigneault*

*Translated by Robert Bononno*

**Perception-consciousness**

(Pcpt.-Cs.)

*Dominique Auffret*

*Translated by Dan Collins*

**Perceptual identity**

*Dominique Auffret*

*Translated by Gwendolyn Wells*

**Perestrello, Danilo**

*Maria de Lourdes Soares O'Donnell*

*Translated by Liam Gavin*

**Perrier, François**

*Jacques Sédat*

*Translated by Gwendolyn Wells*

**Perrotti, Nicola**

*Anna Maria Accerboni*

*Translated by Robert Bononno*

**Persecution**

*Vassilis Kapsambelis*

*Translated by John Galbraith Simmons*

*and Jocelyne Barque*

**Peru**

*Moisés Lemlij*

*Translated by Liam Gavin*

**Perversion**

*Joyce McDougall*

*Translated by Donald Nicholson-Smith*

**Perversion (metapsychological approach)**

*Luiz Eduardo Prado de Oliveira*

*Translated by Sophie Leighton*

**Pfister, Oskar Robert**

*David D. Lee*

- Phallic mother  
*Sylvain Missonnier*  
*Translated by Dan Collins*
- Phallic stage  
*Jean-François Rabain*  
*Translated by Donald Nicholson-Smith*
- Phallic woman  
*Catherine Desprats-Péquignot*  
*Translated by Dan Collins*
- Phallus  
*Bernard Penot*  
*Translated by Dan Collins*
- Phantom  
*Bernard Golse*  
*Translated by Robert Bononno*
- Phenomenology and psychoanalysis  
*Georges Lantéri-Laura*  
*Translated by Donald Nicholson-Smith*
- Philippines  
*Geoffrey H. Blowers*
- Philippson Bible  
*Eva Laible*  
*Translated by Gwendolyn Wells*
- Philosophy and psychoanalysis  
*Bernard Lemaigre*  
*Translated by Robert Bononno*
- Phobia of committing impulsive acts  
*Christiane Guitard-Munnich and Philippe Turmond*  
*Translated by Gwendolyn Wells*
- Phobias in children  
*Claude Bursztejn*  
*Translated by Gwendolyn Wells*
- Phobic neurosis  
*Francis Drossart*  
*Translated by Gwendolyn Wells*
- Phylogenesis  
*Roger Perron*  
*Translated by Liam Gavin*
- Phylogenetic Fantasy, A: Overview of the Transference Neuroses*  
*Ilse Grubrich-Simitis*  
*Translated by Donald Nicholson-Smith*
- Physical pain/psychic pain  
*Laurence Croix*  
*Translated by Gwendolyn Wells*
- Piaget, Jean  
*Fernando Vidal*  
*Translated by John Galbraith Simmons and Jocelyne Barque*
- Pichon, Édouard Jean Baptiste  
*Jean-Pierre Bourgeron*
- Translated by Liam Gavin*
- Pichon-Rivière, Enrique  
*Samuel Arbiser*  
*Translated by Liam Gavin*
- Pictogram  
*Sophie de Mijolla-Mellor*  
*Translated by Gwendolyn Wells*
- Pleasure ego/reality ego  
*Ernst Federn*  
*Translated by Donald Nicholson-Smith*
- Pleasure in thinking  
*Sophie de Mijolla-Mellor*  
*Translated by Philip Beitchman*
- Pleasure/unpleasure principle  
*Francisco Palacio Espasa*  
*Translated by Gwendolyn Wells*
- Poland  
*Michel Vincent*  
*Translated by Liam Gavin*
- Politics and psychoanalysis  
*Roger Dadoun*  
*Translated by Robert Bononno*
- Politzer, Georges  
*Roger Bruyeron*  
*Translated by Robert Bononno*
- Porto-Carrero, Julio Pires  
*Marialzira Perestrello*  
*Translated by Liam Gavin*
- Portugal  
*Pedro Luzes*  
*Translated by Liam Gavin*
- Postnatal/postpartum depression  
*Monique Bydłowski*  
*Translated by Gwendolyn Wells*
- Pötzl, Otto  
*Elke Mühlleitner*  
*Translated by Liam Gavin*
- Preconception  
*Pedro Luzes*  
*Translated by Gwendolyn Wells*
- Preconscious, the  
*Andrée Bauduin*  
*Translated by Gwendolyn Wells*
- Pregenital  
*Dominique J. Arnoux*  
*Translated by Gwendolyn Wells*
- Pregnancy, fantasy of  
*Marie Claire Lanctôt Bélanger*  
*Translated by Gwendolyn Wells*
- Prehistory  
*François Sacco*  
*Translated by Gwendolyn Wells*
- Premature-Prematurity  
*Anne Frichet*  
*Translated by Gwendolyn Wells*
- Premonitory dreams  
*Roger Perron*  
*Translated by Sophie Leighton*
- Prepsychosis  
*Paul Denis*  
*Translated by Gwendolyn Wells*
- Prereflective unconscious  
*Robert D. Stolorow*
- Primal fantasies  
*Sophie de Mijolla-Mellor*  
*Translated by Donald Nicholson-Smith*
- Primal repression  
*Jean-François Rabain*  
*Translated by Donald Nicholson-Smith*
- Primal scene  
*Sophie de Mijolla-Mellor*  
*Translated by Donald Nicholson-Smith*
- Primal, the  
*Sophie de Mijolla-Mellor*  
*Translated by Gwendolyn Wells*
- Primary identification  
*Alain de Mijolla*  
*Translated by Sophie Leighton*
- Primary love  
*Michelle Moreau Ricaud*  
*Translated by Robert Bononno*
- Primary masochism  
*Denys Ribas*  
*Translated by Gwendolyn Wells*
- Primary need  
*Bernard Golse*  
*Translated by Dan Collins*
- Primary object  
*Marie Eugénie Jullian Muzzo Benavides*  
*Translated by Philip Beitchman*
- Primary process/secondary process  
*Roger Perron*  
*Translated by Philip Beitchman*
- Primitive  
*Sophie de Mijolla-Mellor*  
*Translated by Gwendolyn Wells*
- Primitive agony  
*Jennifer Johns*
- Primitive horde  
*Eugène Enriquez*  
*Translated by Robert Bononno*



- Principle of constancy  
*Bertrand Vichyn*  
*Translated by Philip Beitchman*
- Principle of identity preservation  
*Agnès Oppenheimer*  
*Translated by Gwendolyn Wells*
- Principle of (neuronal) inertia  
*Bertrand Vichyn*  
*Translated by Gwendolyn Wells*
- Principles of mental functioning  
*René Roussillon*  
*Translated by Gwendolyn Wells*
- Privation  
*Luiz Eduardo Prado de Oliveira*  
*Translated by Gwendolyn Wells*
- Process  
*Bernard Golse*  
*Translated by Robert Bononno*
- Processes of development  
*Roger Perron*  
*Translated by Liam Gavin*
- Progressive neutralization  
*Arnold Goldberg*
- Prohibition  
*Roger Perron*  
*Translated by Robert Bononno*
- “Project for a Scientific Psychology, A”  
*Bertrand Vichyn*  
*Translated by Donald Nicholson-Smith*
- Projection  
*Roger Perron*  
*Translated by Gwendolyn Wells*
- Projection and “participation mystique” (analytical psychology)  
*Christian Gaillard*  
*Translated by Gwendolyn Wells*
- Projective identification  
*Robert D. Hinshelwood*
- Protective shield  
*Josiane Chambrier*  
*Translated by Gwendolyn Wells*
- Protective shield, breaking through the  
*Josiane Chambrier*  
*Translated by Gwendolyn Wells*
- Proton-pseudos  
*Bernard Golse*  
*Translated by Liam Gavin*
- Protothoughts  
*Pedro Luzes*
- Translated by Gwendolyn Wells*
- Psi( $\psi$ ) system  
*Bertrand Vichyn*  
*Translated by Philip Beitchman*
- Psychanalyse et les nevroses, La  
*Jean-Pierre Bourgeron*  
*Translated by Philip Beitchman*
- Psychanalyse et Pédiatrie* (psychoanalysis and pediatrics)  
*Bernard This*  
*Translated by Liam Gavin*
- Psychanalyse, La*  
*Jacques Sédot*  
*Translated by Dan Collins*
- Psyché, revue internationale de psychanalyse et des sciences de l’homme* (Psyche, an international review of psychoanalysis and human sciences)  
*Jacqueline Cosnier*  
*Translated by Liam Gavin*
- Psyche. Zeitschrift für Psychanalyse und ihre Anwendungen*  
*Hans-Martin Lohmann*  
*Translated by Liam Gavin*
- Psyche/psychism  
*Yvon Brès*  
*Translated by Robert Bononno*
- Psychic apparatus  
*Yvon Brès*  
*Translated by Philip Beitchman*
- Psychic causality  
*Jean-Pierre Chartier*  
*Translated by Robert Bononno*
- Psychic energy  
*Paul Denis*  
*Translated by Philip Beitchman*
- Psychic envelope  
*Didier Anzieu*  
*Translated by Robert Bononno*
- Psychic reality  
*René Roussillon*  
*Translated by Robert Bononno*
- Psychic representative  
*Roger Perron*  
*Translated by Gwendolyn Wells*
- Psychic structure  
*Augustin Jeanneau*  
*Translated by Gwendolyn Wells*
- Psychic temporality
- Sophie de Mijolla-Mellor*  
*Translated by Philip Beitchman*
- Psychoanalyse des névroses et des psychoses, La*  
*Alain de Mijolla*  
*Translated by Philip Beitchman*
- Psychoanalysis  
*Alain de Mijolla*  
*Translated by Robert Bononno*
- Psychoanalysis of Children, The*  
*Francisco Palacio Espasa*  
*Translated by Gwendolyn Wells*
- Psychoanalysis of Dreams*  
*Gilda Sabsay Foks*  
*Translated by Philip Beitchman*
- Psychoanalysis of Fire, The*  
*Bernard Golse*  
*Translated by Robert Bononno*
- Psychoanalyst  
*Alain de Mijolla*  
*Translated by Dan Collins*
- Psychoanalytic epistemology  
*Roland Gori*  
*Translated by Robert Bononno*
- Psychoanalytic family therapy  
*Françoise Diot and Joseph Villier*  
*Translated by Philip Beitchman*
- Psychoanalytic filiations  
*Paul Ries*
- Psychoanalytic nosography  
*Augustin Jeanneau*  
*Translated by Donald Nicholson-Smith*
- “Psycho-Analytic Notes on an Autobiographical Account of a Case of Paranoia (Dementia Paranoides)”  
*Roger Perron*  
*Translated by Donald Nicholson-Smith*
- Psychoanalytic Quarterly, The*  
*Owen Renik*
- Psychoanalytic research  
*Sophie de Mijolla-Mellor*  
*Translated by Robert Bononno*
- Psychoanalytic Review, The*  
*Martin A. Schulman*
- Psychoanalytic semiology  
*Augustin Jeanneau*  
*Translated by Robert Bononno*
- Psychoanalytic Study of the Child, The*  
*George Downing*

*Psychoanalytic Theory of Neuroses, The*

Elke Mühlleitner

Translated by Donald Nicholson-Smith

## Psychoanalytic treatment

Alain de Mijolla

Translated by John Galbraith Simmons and Jocelyne Barque

*Psychoanalytical Treatment of Children*

Frédérique Jacquemain

Translated by Donald Nicholson-Smith

*Psychoanalytische Bewegung, Die*

Lydia Marinelli

Translated by Liam Gavin

## Psychobiography

Larry Shiner

## "Psychogenesis of a Case of Homosexuality in a Woman, The"

Sophie de Mijolla-Mellor

Translated by Sophie Leighton

## Psychogenesis/organogenesis

Claude Smadja

Translated by Gwendolyn Wells

## Psychogenic blindness

Jean-Michel Hirtt

Translated by Liam Gavin

## Psychohistory

Larry Shiner

## Psychological tests

Roger Perron

Translated by Liam Gavin

## Psychological types (analytical psychology)

John Beebe

## Psychology and psychoanalysis

Roger Perron

Translated by Liam Gavin

*Psychology of Dementia præcox*

Bernard Minder

Translated by Liam Gavin

*Psychology of the Unconscious, The*

Viviane Thibaudier

Translated by Liam Gavin

*Psychology of Women, The. A Psychoanalytic Interpretation*

Jacqueline Lanouzière

Translated by Liam Gavin

*Psychopathologie de l'échec (Psychopathology of Failure)*

Jean-Pierre Bourgeron

Translated by Liam Gavin

*Psychopathology of Everyday Life, The*

Gisèle Harrus-Revidi

Translated by Robert Bononno

## Psychoses, chronic and delusional

Michel Demangeat

Translated by Gwendolyn Wells

## Psychosexual development

Jean-François Rabain

Translated by Liam Gavin

## Psychosomatic

Alain Fine

Translated by Robert Bononno

## Psychosomatic limit/boundary

Gisèle Harrus-Revidi

Translated by Gwendolyn Wells

*Psychoterapia (Psixoterapija-Obozrenie voprosov lecenija I prikladnoji psixologii)*

Alexandre Mikhalevitch

Translated by Liam Gavin

## Psychotherapy

Serge Frisch

Translated by Dan Collins

## Psychotic defenses

Elsa Schmid-Kitsikis

Translated by Philip Beitchman

## Psychotic panic

Edna O'Shaughnessy

## Psychotic part of the personality

Edna O'Shaughnessy

## Psychotic potential

Sophie de Mijolla-Mellor

Translated by Philip Beitchman

## Psychotic transference

David Rosenfeld

Translated by Donald Nicholson-Smith

## Psychotic/neurotic

Georges Lantéri-Laura

Translated by Donald Nicholson-Smith

## Puberty

Jean-Jacques Rassial

Translated by Philip Beitchman

## Puerperal psychoses

Odile Cazas

Translated by Gwendolyn Wells

## Punishment, dream of

Roger Perron

Translated by John Galbraith Simmons and Jocelyne Barque

## Purified-pleasure-ego

Alain de Mijolla

Translated by Liam Gavin

## Purposive idea

Roger Perron

Translated by Gwendolyn Wells

## Putnam, James Jackson

Edith Kurzweil

**Q**

## Quantitative/qualitative

Philippe Metello

Translated by Gwendolyn Wells

## Quasi-independence/transitional stage

Jennifer Johns

## Quatrième groupe (O.P.L.F.), Fourth group

Sophie de Mijolla-Mellor

Translated by Dan Collins

*Qu'est-ce que la suggestion?*  
[What is suggestion?]

Mireille Cifali

Translated by Liam Gavin

*Question of Lay Analysis, The*

Roger Perron

Translated by Liam Gavin

## Quota of affect

Francisco Palacio Espasa

Translated by Robert Bononno

**R**

## Racamier, Paul-Claude

Roger Perron

Translated by Gwendolyn Wells

## Racism, antisemitism, and psychoanalysis

Jacques Ascher and Perel Wilgowitz

Translated by Donald Nicholson-Smith

## Racker, Heinrich

R. Horacio Etchegoyen

Translated by Liam Gavin

## Radó, Sándor

Paul Roazen

## Raimbault, Émile

Michelle Moreau Ricaud

Translated by Liam Gavin

## Rambert, Madeleine

Alain de Mijolla

Translated by Robert Bononno

## Rank (Rosenfeld) Otto

E. James Lieberman

- Rank-Minzer (Münzer), Beata  
*Helene Rank-Veltfort*
- Rapaport, David  
*Alain de Mijolla*  
*Translated by Robert Bononno*
- Rascovsky, Arnaldo  
*Elfriede S. Lustig de Ferrer*  
*Translated by Liam Gavin*
- Rationalization  
*Michèle Bertrand*  
*Translated by Robert Bononno*
- Reaction-formation  
*Michèle Bertrand*  
*Translated by John Galbraith Simmons and Jocelyne Barque*
- Real trauma  
*Françoise Brette*  
*Translated by Donald Nicholson-Smith*
- Real, Symbolic, and Imaginary father  
*Patrick De Neuter*  
*Translated by Dan Collins*
- Real, the (Lacan)  
*Martine Lerude*  
*Translated by Dan Collins*
- Reality principle  
*René Roussillon*  
*Translated by Robert Bononno*
- Reality testing  
*René Roussillon*  
*Translated by Dan Collins*
- Realization  
*James S. Grotstein*
- Reciprocal paths of influence  
(libidinal coexcitation)  
*Sophie de Mijolla Mellor*  
*Translated by Gwendolyn Wells*
- “Recommendations to Physicians  
Practicing Psychoanalysis”  
*Alain de Mijolla*  
*Translated by Robert Bononno*
- Rees, John Rawlings  
*Malcolm Pines*
- Régis, Emmanuel Jean-Baptiste  
Joseph  
*Gérard Bazalgette*  
*Translated by Robert Bononno*
- Regression  
*Martine Myquel*  
*Translated by Gwendolyn Wells*
- Reich, Annie  
*Lilli Gast*
- Translated by John Galbraith Simmons and Jocelyne Barque*
- Reich, Wilhelm  
*Roger Dadoun*  
*Translated by Robert Bononno*
- Reik, Theodor  
*Joseph Reppen*
- Relations (commensalism, symbiosis, parasitism)  
*Didier Houzel*  
*Translated by Liam Gavin*
- Relaxation principle and neo-catharsis  
*Pierre Sabourin*  
*Translated by Liam Gavin*
- Relaxation psychotherapy  
*Marie-Lise Roux*  
*Translated by John Galbraith Simmons and Jocelyne Barque*
- Religion and psychoanalysis  
*Odon Vallet*  
*Translated by Robert Bononno*
- Remembering  
*Claude Barrois*  
*Translated by Sophie Leighton*
- “Remembering, Repeating and Working-Through”  
*René Péran*  
*Translated by Sophie Leighton*
- Reminiscences  
*Claude Barrois*  
*Translated by Robert Bononno*
- Reparation  
*Robert D. Hinshelwood*
- Repetition  
*Gérard Bonnet*  
*Translated by Dan Collins*
- Repetition compulsion  
*Gérard Bonnet*  
*Translated by Dan Collins*
- Repetitive dreams  
*Roger Perron*  
*Translated by Sophie Leighton*
- Representability  
*Katia Varenne*  
*Translated by Dan Collins*
- Representation of affect  
*Roger Perron*  
*Translated by Gwendolyn Wells*
- Repressed  
*Jean-François Rabain*
- Translated by Dan Collins*
- Repressed, derivative of the; derivative of the unconscious  
*Jean-François Rabain*  
*Translated by Gwendolyn Wells*
- Repression  
*Jean-François Rabain*  
*Translated by Gwendolyn Wells*
- “Repression”  
*Sophie de Mijolla-Mellor*  
*Translated by Gwendolyn Wells*
- Repression, lifting of  
*Jean-François Rabain*  
*Translated by Dan Collins*
- Repudiation  
*Bernard Penot*  
*Translated by Gwendolyn Wells*
- Rescue fantasies  
*Roger Perron*  
*Translated by Gwendolyn Wells*
- Resistance  
*Michèle Pollak Cornillot*  
*Translated by Dan Collins*
- Resolution of the transference  
*Paul Denis*  
*Translated by Donald Nicholson-Smith*
- Return of the repressed  
*Jean-François Rabain*  
*Translated by Donald Nicholson-Smith*
- Reverchon-Jouve, Blanche  
*Jean-Pierre Bourgeron*  
*Translated by Robert Bononno*
- Reverie  
*Roger Perron*  
*Translated by Dan Collins*
- Reversal into the opposite  
*Roger Perron*  
*Translated by Gwendolyn Wells*
- Revista de psicoanálisis*  
*Carlos Mario Aslan*
- Revista de psiquiatria y disciplinas conexas*  
*Álvaro Rey de Castro*  
*Translated by Liam Gavin*
- Revue française de psychanalyse*  
*Alain de Mijolla*  
*Translated by Dan Collins*
- Richard, case of  
*Robert D. Hinshelwood*
- Rickman, John  
*Pearl H. M. King*

Rie, Oskar  
*Alain de Mijolla*  
Translated by John Galbraith Simmons  
and Jocelyne Barque

Rite and ritual  
*Michèle Porte*  
Translated by Gwendolyn Wells

Rittmeister, John Friedrich Karl  
*Ludger M. Hermanns*  
Translated by Liam Gavin

Rivalry  
*Steven Wainrib*  
Translated by Gwendolyn Wells

Riviere-Hodgson Verrall, Joan  
*Athol Hughes*

*Rivisita di psicoanalisi*  
*Rosario Merendino*  
Translated by Robert Bononno

Robertson, James  
*Jennifer Johns*

Róheim, Géza  
*Éva Brabant-Gerő*  
Translated by John Galbraith Simmons  
and Jocelyne Barque

Rolland, Romain Edme Paul-Émile  
*Henri Vermorel and Madeleine Vermorel*  
Translated by John Galbraith Simmons  
and Jocelyne Barque

Romania  
*Michel Vincent*  
Translated by Liam Gavin

Rorschach, Hermann  
*Mireille Cifali*  
Translated by John Galbraith Simmons  
and Jocelyne Barque

Rosenfeld, Eva Marie  
*Alain de Mijolla*  
Translated by Liam Gavin

Rosenfeld, Herbert Alexander  
*Riccardo Steiner*

Rosenthal, Tatiana  
*Anna Maria Accerboni*  
Translated by Liam Gavin

Ross, Helen  
*Nellie L. Thompson*

Rubinstein, Benjamin B.  
*Robert R. Holt*

Russia/USSR  
*Alexandre Mikhalevitch*  
Translated by John Galbraith Simmons  
and Jocelyne Barque

Rycroft, Charles Frederick  
*Paul Roazen*

## S

Sachs, Hanns  
*Reiner Wild*  
Translated by Gwendolyn Wells

Sadger, Isidor Isaak  
*Bertrand Vichyn*  
Translated by John Galbraith Simmons  
and Jocelyne Barque

Sadism  
*Denys Ribas*  
Translated by Gwendolyn Wells

Sadomasochism  
*Denys Ribas*  
Translated by Gwendolyn Wells

Sainte-Anne Hospital  
*Jean Garrabé*  
Translated by Dan Collins

Salpêtrière Hospital, La  
*Daniel Widlöcher*  
Translated by Robert Bononno

San Francisco Psychoanalytic Society  
*Robert S. Wallerstein*

San Francisco Psychotherapy  
Research Group and Control-Mas-  
tery Theory  
*Robert Shilkret*

Sandler, Joseph  
*Riccardo Steiner*

Sarasin, Philipp  
*Kaspar Weber*  
Translated by Liam Gavin

Sartre and psychoanalysis  
*Georges Lantéri-Laura*  
Translated by John Galbraith Simmons  
and Jocelyne Barque

Saussure, Raymond de  
*Jean-Michel Quinodoz*  
Translated by Liam Gavin

Schiff, Paul  
*Claire Doz-Schiff*  
Translated by John Galbraith Simmons  
and Jocelyne Barque

Schilder, Paul Ferdinand  
*Alain de Mijolla*  
Translated by Gwendolyn Wells

Schiller and psychoanalysis  
*Madeleine Vermorel*  
Translated by Gwendolyn Wells

Schizophrenia

*Michel Demangeat*  
Translated by Robert Bononno

Schlumberger, Marc  
*Jean-Pierre Bourgeron*  
Translated by Liam Gavin

Schmideberg-Klein, Melitta  
*Pearl H. M. King*

Schmidt, Vera Federovna  
*Irina Manson*  
Translated by Liam Gavin

Schneider, Ernst  
*Jeanne Moll*  
Translated by Gwendolyn Wells

Schreber, Daniel Paul  
*Zvi Lothane*

Schultz-Hencke, Harald Julius Alfred  
Carl-Ludwig  
*Regine Lockot*  
Translated by Liam Gavin

Schur, Max  
*Roy K. Lilleskov*

Schweizerische Ärztegesellschaft für  
Psychoanalyse  
*Mireille Cifali*  
Translated by Liam Gavin

Science and psychoanalysis  
*Roland Gori*  
Translated by Robert Bononno

Scilicet  
*Jacques Sédat*  
Translated by Andrew Brown

Scoptophilia/scopophilia  
*Alain de Mijolla*  
Translated by Dan Collins

Scotomization  
*Alain de Mijolla*  
Translated by Dan Collins

Screen memory  
*François Richard*  
Translated by Donald Nicholson-Smith

Sechehaye-Burdet, Marguerite  
*Mario Cifali*  
Translated by John Galbraith Simmons  
and Jocelyne Barque

Second World War: The effect on the  
development of psychoanalysis  
*Alain de Mijolla*  
Translated by Robert Bononno

Secondary revision  
*François Duparc*  
Translated by Gwendolyn Wells

- Secret  
*Anne-Marie Mairesse*  
Translated by Robert Bononno
- Secret Committee  
*Gerhard Wittenberger*  
Translated by Robert Bononno
- Secrets of a Soul*  
*Paul Ries*
- Seduction  
*Henri Sztulman*  
Translated by Donald Nicholson-Smith
- Seduction scenes  
*Roger Perron*  
Translated by Donald Nicholson-Smith
- Selected fact  
*Didier Houzel*  
Translated by Gwendolyn Wells
- Self  
*Maurice Despinoy and Monique Piñol-Douriez*  
Translated by Gwendolyn Wells
- Self-analysis  
*Didier Anzieu*  
Translated by Dan Collins
- Self (analytical psychology)  
*Joseph L. Henderson*
- Self-consciousness  
*Marie Claire Lanctôt Bélange*  
Translated by Gwendolyn Wells
- Self-esteem  
*Raymond Cahn*  
Translated by Liam Gavin
- Self-hatred  
*Nicole Jeammet*  
Translated by Gwendolyn Wells
- Self-image  
*Philippine Meffre*  
Translated by Gwendolyn Wells
- Self-mutilation in children  
*Claude Bursztejn*  
Translated by Robert Bononno
- Self-object  
*Agnès Oppenheimer*  
Translated by Gwendolyn Wells
- Self-preservation  
*Roger Perron*  
Translated by Liam Gavin
- Self-punishment  
*Bertrand Étienne and Dominique Deyon*  
Translated by Philip Beitchman
- Self psychology
- Agnès Oppenheimer*  
Translated by Gwendolyn Wells
- Self-representation  
*Raymond Cahn*  
Translated by Gwendolyn Wells
- Self-state dream  
*Arnold Goldberg*
- Self, the  
*Bernard Golse*  
Translated by Philip Beitchman
- Self (true/false)  
*Jennifer Johns*
- Seminar, Lacan's  
*Jacques Sédat*  
Translated by Dan Collins
- Sense/nonsense  
*Sophie de Mijolla-Mellor*  
Translated by Gwendolyn Wells
- Servadio, Emilio  
*Anna Maria Accerboni*  
Translated by Robert Bononno
- "Seventeenth-Century Demonological Neurosis, A"  
*Roger Perron*  
Translated by Gwendolyn Wells
- Sex and Character*  
*Erik Porge*  
Translated by Liam Gavin
- Sexual differences  
*Paulo R. Ceccarelli*  
Translated by Robert Bononno
- Sexual drive  
*Michèle Porte*  
Translated by Dan Collins
- "Sexual Enlightenment Of Children, The"  
*Sophie de Mijolla-Mellor*  
Translated by Robert Bononno
- Sexual theories of children  
*Sophie de Mijolla-Mellor*  
Translated by Donald Nicholson-Smith
- Sexual trauma  
*Françoise Brette*  
Translated by Donald Nicholson-Smith
- Sexuality  
*Colette Chiland*  
Translated by Donald Nicholson-Smith
- Sexualization  
*Arnold Goldberg*
- Sexuation, formulas of  
*Alain Vanier*  
Translated by Dan Collins
- Shadow (analytical psychology)  
*Hans Dieckmann*  
Translated by Robert Bononno
- Shakespeare and psychoanalysis  
*Margaret Ann Fitzpatrick Hanly*
- Shame  
*Serge Tisseron*  
Translated by Dan Collins
- Sharpe, Ella Freeman  
*Pearl H. M. King*
- Sigmund Freud Archives  
*Harold P. Blum*
- Sigmund Freud Copyrights Limited  
*Thomas Roberts and Mark Paterson*
- Sigmund Freud Institute  
*Michael Laier*  
Translated by John Galbraith Simmons and Jocelyne Barque
- Sigmund Freud Museum  
*Ingrid Scholz-Strasser*  
Translated by John Galbraith Simmons and Jocelyne Barque
- Signal anxiety  
*Bernard Golse*  
Translated by Robert Bononno
- Signifier  
*Julia Kristeva*  
Translated by Donald Nicholson-Smith
- Signifier/signified  
*Joël Dor*  
Translated by Gwendolyn Wells
- Signifying chain  
*Joël Dor*  
Translated by Dan Collins
- Silberer, Herbert  
*Alain de Mijolla*  
Translated by John Galbraith Simmons and Jocelyne Barque
- Silberstein, Eduard  
*Alain de Mijolla*  
Translated by John Galbraith Simmons and Jocelyne Barque
- Silence  
*Pearl Lombard*  
Translated by Andrew Brown
- Simmel, Ernst  
*Ludger M. Hermanns and Ulrich Schultz-Venrath*  
Translated by John Galbraith Simmons and Jocelyne Barque
- Skin  
*Didier Anzieu*

- Translated by Donald Nicholson-Smith*
- Skin-ego  
*Didier Anzieu*  
*Translated by Donald Nicholson-Smith*
- Sleep/wakefulness  
*Philippe Metello*  
*Translated by Gwendolyn Wells*
- Slips of the tongue  
*Sophie de Mijolla-Mellor*  
*Translated by Robert Bononno*
- Smell, sense of  
*Dominique J. Arnoux*  
*Translated by Gwendolyn Wells*
- Smirnoff, Victor Nikolaïevitch  
*Hélène Trivouss-Widlöcher*  
*Translated by Donald Nicholson-Smith*
- Social feeling (individual psychology)  
*François Compan*  
*Translated by Gwendolyn Wells*
- Société française de psychanalyse  
*Jean-Louis Lang*  
*Translated by Gwendolyn Wells*
- Société psychanalytique de Genève  
*Jean-Michel Quinodoz*  
*Translated by Liam Gavin*
- Société psychanalytique de Montréal  
*Jacques Vigneault*  
*Translated by Liam Gavin*
- Société psychanalytique de Paris and  
Institut de psychanalyse de Paris  
*Alain de Mijolla*  
*Translated by Gwendolyn Wells*
- Sociology and psychoanalysis/  
sociopsychanalysis  
*Eugène Enriquez*  
*Translated by Liam Gavin*
- Sokolnicka-Kutner, Eugénie  
*Alain de Mijolla*  
*Translated by Liam Gavin*
- Somatic compliance  
*Alain Fine*  
*Translated by Gwendolyn Wells*
- “Some Psychical Consequences of  
the Anatomical Distinction  
between the Sexes”  
*Colette Chiland*  
*Translated by Donald Nicholson-Smith*
- Somnambulism  
*Philippe Metello*  
*Translated by Gwendolyn Wells*
- Spain  
*Maria Luisa Muñoz*  
*Translated by Liam Gavin*
- Specific action  
*Roger Perron*  
*Translated by Philip Beitchman*
- Spielrein, Sabina  
*Nicolle Kress-Rosen*  
*Translated by John Galbraith Simmons  
and Jocelyne Barque*
- Spinoza and psychoanalysis  
*Michèle Bertrand*  
*Translated by John Galbraith Simmons  
and Jocelyne Barque*
- Spitz, René Arpad  
*Kathleen Kelley-Lainé*  
*Translated by John Galbraith Simmons  
and Jocelyne Barque*
- Split object  
*Panos Aloupis*  
*Translated by Dan Collins*
- Splits in psychoanalysis  
*Alain de Mijolla*  
*Translated by Dan Collins*
- Splitting  
*Sophie de Mijolla-Mellor*  
*Translated by Dan Collins*
- Splitting of the ego  
*Sophie de Mijolla-Mellor*  
*Translated by Donald Nicholson-Smith*
- “Splitting of the Ego in the Process of  
Defense, The”  
*Sophie de Mijolla-Mellor*  
*Translated by Sophie Leighton*
- Splitting of the object  
*Robert D. Hinshelwood*
- Splitting of the subject  
*Alain Vanier*  
*Translated by Gwendolyn Wells*
- Splitting, vertical and horizontal  
*Arnold Goldberg*
- Squiggle  
*Jennifer Johns*
- Stage (or phase)  
*Jean-François Rabain*  
*Translated by Donald Nicholson-Smith*
- Stammering  
*Christiane Payan*  
*Translated by Liam Gavin*
- Standard Edition of the Complete Psy-  
chological Works of Sigmund Freud*  
*Riccardo Steiner*
- State of being in love  
*Laurent Danon-Boileau*  
*Translated by Robert Bononno*
- Stekel, Wilhelm  
*Francis Clark-Lowes*
- Sterba, Richard F.  
*Elke Mühlleitner*  
*Translated by John Galbraith Simmons  
and Jocelyne Barque*
- Sterba-Radanowicz-Hartmann,  
Editha  
*Elke Mühlleitner*  
*Translated by John Galbraith Simmons  
and Jocelyne Barque*
- Stoller, Robert J.  
*Christopher Gelber*
- Stone, Leo  
*Zvi Lothane*
- Storfer, Adolf Josef  
*Ingrid Scholz-Strasser*  
*Translated by Liam Gavin*
- Strachey, James Beaumont  
*Riccardo Steiner*
- Strachey-Sargent, Alix  
*Riccardo Steiner*
- Stranger  
*Léon Kreisler*  
*Translated by Gwendolyn Wells*
- Strata/stratification  
*Michèle Porte*  
*Translated by Gwendolyn Wells*
- Structural theories  
*Roger Perron*  
*Translated by Donald Nicholson-Smith*
- Structuralism and psychoanalysis  
*Dominique Auffret*  
*Translated by Andrew Brown*
- Studienausgabe  
*Ilse Grubrich-Simitis*  
*Translated by Donald Nicholson-Smith*
- Studies on Hysteria*  
*Alain de Mijolla*  
*Translated by Robert Bononno*
- Subconscious  
*Annick Ohayon*  
*Translated by Philip Beitchman*
- Subject  
*Raymond Cahn*  
*Translated by Gwendolyn Wells*
- Subject of the drive  
*Marie-Christine Laznik*

- Translated by Dan Collins*  
 Subject of the unconscious  
*Bernard Penot*  
*Translated by Philip Beitchman*
- Subject's castration  
*Luiz Eduardo Prado de Oliveira*  
*Translated by Dan Collins*
- Subject's desire  
*Patrick Delaroche*  
*Translated by Dan Collins*
- Sublimation  
*Sophie de Mijolla-Mellor*  
*Translated by Robert Bononno*
- Substitute/substitutive formation  
*Mathieu Zannotti*  
*Translated by Gwendolyn Wells*
- Substitutive formation  
*Roger Perron*  
*Translated by Philip Beitchman*
- Sucking/thumbsucking  
*Anne-Marie Mairesse*  
*Translated by John Galbraith Simmons and Jocelyne Barque*
- Sudden involuntary idea  
*Sophie de Mijolla-Mellor*  
*Translated by Gwendolyn Wells*
- Suffering  
*Drina Candilis-Huisman*  
*Translated by Donald Nicholson-Smith*
- Suggestion  
*Jacqueline Carroy*  
*Translated by Robert Bononno*
- Suicidal behavior  
*Sophie de Mijolla-Mellor*  
*Translated by Gwendolyn Wells*
- Suicide  
*Sophie de Mijolla-Mellor*  
*Translated by Philip Beitchman*
- Sullivan, Harry Stack  
*Marco Conci*
- Sum of excitation  
*Michèle Porte*  
*Translated by Donald Nicholson-Smith*
- Superego  
*Jean-Luc Donnet*  
*Translated by Donald Nicholson-Smith*
- Supervised analysis (control case)  
*Roger Perron*  
*Translated by Liam Gavin*
- Suppression  
*Francisco Palacio Espasa*
- Translated by Dan Collins*  
 Surrealism and psychoanalysis  
*Nicole Geblesco*  
*Translated by Robert Bononno*
- Sweden  
*Per Magnus Johansson and David Titelman*  
*Translated by Liam Gavin*
- Switzerland (French-speaking)  
*Jean-Michel Quinodoz*  
*Translated by Liam Gavin*
- Switzerland (German-speaking)  
*Kaspar Weber*  
*Translated by Liam Gavin*
- Swoboda, Hermann  
*Erik Porge*  
*Translated by John Galbraith Simmons and Jocelyne Barque*
- Symbiosis/symbiotic relation  
*Cléopâtre Athanassiou-Popesco*  
*Translated by Andrew Brown*
- Symbol  
*Alain Gibeault*  
*Translated by Dan Collins*
- Symbolic equation  
*Hanna Segal*
- Symbolic realization  
*Jean-Michel Quinodoz*  
*Translated by Liam Gavin*
- Symbolic, the (Lacan)  
*Jean-Paul Hiltenbrand*  
*Translated by Dan Collins*
- Symbolism  
*Harold P. Blum*
- Symbolization, process of  
*Alain Gibeault*  
*Translated by Robert Bononno*
- Symptom  
*Augustin Jeanneau*  
*Translated by Dan Collins*
- Symptom-formation  
*Augustin Jeanneau and Roger Perron*  
*Translated by Donald Nicholson-Smith*
- Symptom/sinthome  
*Valentin Nusinovic*  
*Translated by Dan Collins*
- Synchronicity (analytical psychology)  
*John Beebe*
- System/systemic  
*Françoise Diot and Joseph Villier*
- Translated by Dan Collins*  
 Szondi, Leopold  
*Jacques Schotte*  
*Translated by John Galbraith Simmons and Jocelyne Barque*
- T**
- Taboo  
*Michèle Porte*  
*Translated by Robert Bononno*
- "Taboo of Virginity, The"  
*Roger Perron*  
*Translated by John Galbraith Simmons and Jocelyne Barque*
- Tact  
*Pierre Sabourin*  
*Translated by Philip Beitchman*
- Tausk, Viktor  
*Marie-Thérèse Neyraut-Sutterman*  
*Translated by John Galbraith Simmons and Jocelyne Barque*
- Tavistock Clinic  
*Marcus Johns*
- Technique with adults,  
 psychoanalytic  
*Alain de Mijolla*  
*Translated by Philip Beitchman*
- Technique with children,  
 psychoanalytic  
*Bernard Golse*  
*Translated by Philip Beitchman*
- Tegel (Schloss Tegel)  
*Ludger M. Hermanns and Ulrich Schultz-Venrath*  
*Translated by Liam Gavin*
- Telepathy  
*Sophie de Mijolla-Mellor*  
*Translated by Robert Bononno*
- Tenderness  
*Régine Prat*  
*Translated by Robert Bononno*
- Termination of treatment  
*Alain de Mijolla*  
*Translated by Dan Collins*
- Thalassa. A Theory of Genitality*  
*Pierre Sabourin*  
*Translated by Donald Nicholson-Smith*
- "Theme of the Three Caskets, The"  
*Ilse Grubrich-Simitis*  
*Translated by Sophie Leighton*
- Therapeutic alliance  
*Alain de Mijolla*

- Translated by Robert Bononno*
- Thing, the  
*Jean-Paul Hiltenbrand*  
*Translated by Dan Collins*
- Thing-presentation  
*Alain Gibeault*  
*Translated by Donald Nicholson-Smith*
- Thomas Woodrow Wilson, Twenty-eighth President of the United States. A Psychological Study*  
*Alain de Mijolla*  
*Translated by Robert Bononno*
- Thompson, Clara M.  
*Sue A. Shapiro*
- Thought  
*Sophie de Mijolla-Mellor*  
*Translated by Donald Nicholson-Smith*
- Thought identity  
*Dominique Auffret*  
*Translated by Gwendolyn Wells*
- “Thoughts for the Times on War and Death”  
*Sophie de Mijolla-Mellor*  
*Translated by Robert Bononno*
- Thought-thinking apparatus  
*Pedro Luzes*  
*Translated by Gwendolyn Wells*
- Three Essays on the Theory of Sexuality*  
*Roger Perron*  
*Translated by John Galbraith Simmons and Jocelyne Barque*
- Tics  
*Christiane Payan*  
*Translated by Gwendolyn Wells*
- Time  
*Sophie de Mijolla-Mellor*  
*Translated by Robert Bononno*
- Tomasi di Palma di Lampedusa-Wolff  
Somerset, Alessandra  
*Anna Maria Accerboni*  
*Translated by Robert Bononno*
- Topique*  
*Sophie de Mijolla-Mellor*  
*Translated by Philip Beitchman*
- Topographical point of view  
*René Roussillon*  
*Translated by Donald Nicholson-Smith*
- Topology  
*Bernard Vandermersch*  
*Translated by Dan Collins*
- Torok, Maria  
*Jacques Sédot*  
*Translated by Gwendolyn Wells*
- Tosquelles, François  
*Pierre Delion*  
*Translated by Liam Gavin*
- Totem and Taboo*  
*Michèle Porte*  
*Translated by Robert Bononno*
- Totem/totemism  
*Michèle Porte*  
*Translated by Robert Bononno*
- Training analysis  
*Alain de Mijolla*  
*Translated by Dan Collins*
- Training of the psychoanalyst  
*Jean-Luc Donnet*  
*Translated by Robert Bononno*
- Trance  
*Jacqueline Carroy*  
*Translated by Gwendolyn Wells*
- Transcultural  
*Marie-Rose Moro*  
*Translated by Gwendolyn Wells*
- Transference  
*Paul Denis*  
*Translated by Donald Nicholson-Smith*
- Transference and Countertransference*  
*Fidias Cesio*  
*Translated by Gwendolyn Wells*
- Transference/counter-transference (analytical psychology)  
*Jean Kirsch*
- Transference depression  
*Jean-François Rabain*  
*Translated by Gwendolyn Wells*
- Transference hatred  
*Jean-François Rabain*  
*Translated by Gwendolyn Wells*
- Transference in children  
*Bernard Golse*  
*Translated by Gwendolyn Wells*
- Transference love  
*Jean-François Rabain*  
*Translated by Donald Nicholson-Smith*
- Transference neurosis  
*Gail S. Reed*
- Transference of creativity  
*Agnès Oppenheimer*  
*Translated by Gwendolyn Wells*
- Transference relationship  
*Paul Denis*  
*Translated by Donald Nicholson-Smith*
- Transformations  
*James S. Grotstein*
- Transgression  
*Simon-Daniel Kipman*  
*Translated by Andrew Brown*
- Transitional object  
*Nora Scheimberg*  
*Translated by Donald Nicholson-Smith*
- Transitional object, space  
*Jennifer Johns*
- Transitional phenomena  
*Campbell Paul and Ann Morgan*
- Translation  
*Michèle Pollak Cornillot*  
*Translated by Robert Bononno*
- Transmuting internalization  
*Arnold Goldberg*
- Transsexualism  
*Colette Chiland*  
*Translated by Liam Gavin*
- Trattato di psicoanalisi*  
*Giancarlo Gramaglia*  
*Translated by Robert Bononno*
- Trauma  
*Françoise Brette*  
*Translated by Donald Nicholson-Smith*
- Trauma of Birth, The*  
*Didier Houzel*  
*Translated by Donald Nicholson-Smith*
- Traumatic neurosis  
*Françoise Brette*  
*Translated by Donald Nicholson-Smith*
- Truth  
*Sophie de Mijolla-Mellor*  
*Translated by Dan Collins*
- Tube-ego  
*Bernard Golse*  
*Translated by Liam Gavin*
- Turning around  
*Roger Perron*  
*Translated by Dan Collins*
- Turning around upon the subject's own self  
*Jean-Baptiste Déthieux*  
*Translated by Gwendolyn Wells*
- Tustin, Frances  
*Didier Houzel*



*Translated by Gwendolyn Wells*

Twinship transference/alter ego  
transference

*Agnès Oppenheimer*

*Translated by Gwendolyn Wells*

Typical dreams

*Roger Perron*

*Translated by Sophie Leighton*

## U

Ulcerative colitis

*Alain Fine*

*Translated by Gwendolyn Wells*

Unary trait

*Marc Darmon*

*Translated by Dan Collins*

“‘Uncanny,’ The”

*Sophie de Mijolla-Mellor*

*Translated by Robert Bononno*

*Unconscious as Infinite Sets, The: An  
Essay in Bi-Logic*

*Juan Francisco Jordan Moore*

*Translated by Philip Beitchman*

Unconscious concept

*Sophie de Mijolla-Mellor*

*Translated by Dan Collins*

Unconscious fantasy

*Robert D. Hinshelwood*

Unconscious, the

*Michèle Porte*

*Translated by Dan Collins*

“Unconscious, The”

*Sophie de Mijolla-Mellor*

*Translated by Robert Bononno*

Undoing

*Elsa Schmid-Kitsikis*

*Translated by Robert Bononno*

United States

*Edith Kurzweil*

Unpleasure

*Michèle Pollak Cornillot*

*Translated by Gwendolyn Wells*

Unvalidated unconscious

*Robert D. Stolorow*

Urbantschitsch (Urban), Rudolf von

*Elke Mühlleitner*

*Translated by Liam Gavin*

Uruguay

*Sélika Acevedo de Mendilaharsu*

*Translated by Liam Gavin*

## V

“Vagina dentata,” fantasy of

*Marie Claire Lanctôt Bélanger*

*Translated by Dan Collins*

Valdizán, Hermilio

*Álvaro Rey de Castro*

*Translated by Liam Gavin*

Venezuela

*Rafael E. López-Corvo*

*Translated by Liam Gavin*

Vertex

*Didier Houzel*

*Translated by Gwendolyn Wells*

Videman, Serge

*Alain de Mijolla*

*Translated by Gwendolyn Wells*

Vienna General Hospital

*Eva Laible*

*Translated by John Galbraith Simmons*

*and Jocelyne Barque*

Vienna, Freud’s secondary  
school in

*Eva Laible*

*Translated by Gwendolyn Wells*

Vienna, University of

*Eva Laible*

*Translated by Liam Gavin*

*Violence of Interpretation, The: From  
Pictogram to Statement*

*Sophie de Mijolla-Mellor*

*Translated by Gwendolyn Wells*

Violence, instinct of

*Jean Bergeret*

*Translated by Gwendolyn Wells*

Visual

*Jean-Michel Hirtt*

*Translated by Dan Collins*

Visual arts and psychoanalysis

*Michel Artières*

*Translated by Robert Bononno*

Voyeurism

*Jean-Michel Hirtt*

*Translated by Robert Bononno*

## W

Waelder, Robert

*Elke Mühlleitner*

*Translated by John Galbraith Simmons*

*and Jocelyne Barque*

Wagner-Jauregg, Julius (Julius

Wagner Ritter von Jauregg)

*Eva Laible*

*Translated by John Galbraith Simmons  
and Jocelyne Barque*

Walter, Bruno

*Nicolas Gougoulis*

*Translated by John Galbraith Simmons*

*and Jocelyne Barque*

Want of being/lack of being

*Alain Vanier*

*Translated by Dan Collins*

War neurosis

*Anne Bizot*

*Translated by Dan Collins*

Washington Psychoanalytic Society

*John Galbraith Simmons*

Weaning

*Grazia Maria Fava Vizziello*

*Translated by Gwendolyn Wells*

Weininger, Otto

*Erik Porge*

*Translated by John Galbraith Simmons*

*and Jocelyne Barque*

Weiss, Edoardo

*Anna Maria Accerboni*

*Translated by Robert Bononno*

*Weltanschauung*

*Sophie de Mijolla-Mellor*

*Translated by Philip Beitchman*

“Why War?”

*Alain de Mijolla*

*Translated by Gwendolyn Wells*

Wiener psychoanalytische  
Vereinigung

*Wilhelm Burian*

*Translated by John Galbraith Simmons*

*and Jocelyne Barque*

Wilbur, George B.

*Paul Roazen*

“‘Wild’ Psycho-Analysis”

*Alain de Mijolla*

*Translated by Donald Nicholson-Smith*

Winnicott, Donald Woods

*Jennifer Johns*

Winterstein, Alfred Freiherr von

*Harald Leupold-Löwenthal*

*Translated by John Galbraith Simmons*

*and Jocelyne Barque*

Wish for a baby

*Christine Petit*

*Translated by Donald Nicholson-Smith*

Wish, hallucinatory satisfaction of a

*Roger Perron*

*Translated by Philip Beitchman*

Wish/yearning

*Gérard Bonnet*

*Translated by Philip Beitchman*

Wish-fulfillment

*Delphine Schilton*

*Translated by Philip Beitchman*

Witch of Metapsychology, the

*Roger Perron*

*Translated by Liam Gavin*

Wittels, Fritz (Siegfried)

*Elke Mühlleitner*

*Translated by John Galbraith Simmons  
and Jocelyne Barque*

Wittkower, Eric

*Patrick Mahony*

Wolfenstein, Martha

*Nellie L. Thompson*

Wolff, Antonia Anna

*Thomas B. Kirsch*

Word association

*Renos K. Papadopoulos*

Word-presentation

*Alain Gibeault*

*Translated by Donald Nicholson-Smith*

Work (as a psychoanalytical notion)

*Michèle Pollak Cornillot*

*Translated by Donald Nicholson-Smith*

Working-off mechanisms

*Elsa Schmid-Kitsikis*

*Translated by Gwendolyn Wells*

Working over

*François Duparc*

*Translated by Gwendolyn Wells*

Working-through

*René Péran*

*Translated by Gwendolyn Wells*

Wulff, Mosche (Woolf, Moshe)

*Ruth Kloocke*

*Translated by John Galbraith Simmons  
and Jocelyne Barque*

## Y

*Young Girl's Diary, A*

*Alain de Mijolla*

*Translated by Robert Bononno*

Yugoslavia (ex-)

*Michel Vincent*

*Translated by Liam Gavin*

## Z

Zavitzianos, Georges

*Anna Potamianou*

*Translated by John Galbraith Simmons  
and Jocelyne Barque*

*Zeitschrift für psychoanalytische  
Pädagogik*

*Jeanne Moll*

*Translated by Liam Gavin*

*Zentralblatt für Psychoanalyse*

*Lydia Marinelli*

*Translated by Liam Gavin*

Zetzel-Rosenberg, Elizabeth

*Nellie L. Thompson*

Zulliger, Hans

*Jeanne Moll*

*Translated by Liam Gavin*

Zweig, Arnold

*Bernard Golse*

*Translated by John Galbraith Simmons  
and Jocelyne Barque*

Zweig, Stefan

*Christine de Kerchove*

*Translated by John Galbraith Simmons  
and Jocelyne Barque*

# DIRECTORY OF CONTRIBUTORS

## ДИРЕКТОРЪ ОЕ КОНТРИБУТОРЪ

With texts originating from regions all over the world, each possessing its own unique conventions, and in order to maintain the Dictionary's character as an international work, we have refrained from standardizing the biographies sent to us by the 463 authors who contributed to it.

Liliane Abensour  
*Psychoanalyst*  
*Member*  
*Société psychanalytique de Paris*

Anna Maria Accerboni  
*Instructor of Dynamic Psychology*  
*University of Trieste*  
*Psychotherapist*  
*Member*  
*International Association for the History of Psychoanalysis*

Sélika Acevedo de Mendilaharsu, M.D.  
*Professor Emeritus*  
*Titular Member*  
*Psychoanalytic Association of Uruguay*

Aimé Agneel  
*Psychoanalyst*  
*Member*  
*Société française de psychologie analytique*

Jorge L. Ahumada  
*Training Analyst*  
*Buenos Aires Psychoanalytic Association*  
*Editor for Latin America, International Journal of Psychoanalysis*

Brigitte Allain-Dupré  
*Psychoanalyst*  
*Member*  
*Société française de psychologie analytique*

*Director*  
*Institut C. G. Jung (Paris)*

Panos Aloupis  
*Psychiatrist and Psychoanalyst*  
*Member*  
*Société psychanalytique de Paris*

André Alsteens  
*Former President*  
*Société belge de psychanalyse*  
*Director*  
*Centre de guidance pour enfants et adolescents à Uccle-Bruxelles*

Nadine Amar  
*Psychoanalyst*  
*Titular Member*  
*Société psychanalytique de Paris*

Jacques Angelergues  
*Doctor, Psychiatrist and Child Psychiatrist*  
*Member*  
*Société psychanalytique de Paris*

Didier Anzieu  
*Psychoanalyst*  
*Member*  
*Association psychanalytique de France*

Christine Anzieu-Premereur  
*Psychoanalyst and Child Psychiatrist*  
*Doctor at the Centre Alfred-Binet, Paris*

Samuel Arbiser  
*Doctor*  
*Titular Training Member*

*Asociación Psicoanalítica de Buenos Aires*

Jean-Claude Arfouilloux  
*Doctor, Psychiatrist, and Psychoanalyst*  
*Member*  
*Association psychanalytique de France*

Dominique J. Arnoux  
*Psychiatrist and Psychoanalyst*  
*Titular Member*  
*Société psychanalytique de Paris*

Omar Arrué  
*Full Member*  
*International Psychoanalytical Association*  
*Titular Member, Training Analyst, and Past President*  
*Asociación Psicoanalítica Chilena*

Michel Artières  
*Doctor and Psychoanalyst*  
*Member*  
*Quatrième Groupe-O.P.L.F.*

Jacques Ascher  
*Doctor*  
*Centre hospitalier et universitaire de Lille*  
*Member*  
*Société psychanalytique de Paris*

Carlos Mario Aslan  
*President, Member, and Training Analyst*  
*Argentine Psychoanalytic Association*  
*Member*

- International Psychoanalytical Association*
- Robert Asséo  
*Psychiatrist and Psychoanalyst  
Medical Director  
Institut de psychosomatique*
- Cléopâtre Athanassiou-Popesco  
*Psychoanalyst*
- Anne Aubert-Godard  
*Professor of Psychopathology  
Director, Laboratory of Health and  
Psychopathology  
University of Haute-Normandie*
- Dominique Auffret  
*Docteur d'Etat in Letters and the  
Human Sciences  
Professor of Fundamental Psychology  
EFP in Lyon*
- Gabriel Balbo  
*Psychoanalyst and Psychodramatist  
Director  
Psychanalyse de l'enfant*
- Madeleine Baranger  
*Member  
Argentine Psychoanalytic Association*
- Claude Barrois  
*Tenured Professor of Psychiatry  
Val-de-Grâce  
Member  
Association psychanalytique de France*
- Andrée Bauduin  
*Psychiatrist and Psychoanalyst  
Titular Member, Société psychanaly-  
tique de Paris*
- Gérard Bazalgette  
*Psychiatrist-Member  
Quatrième Groupe-O.P.L.F.*
- John E. Beebe  
*Jungian Analyst  
Assistant Clinical Professor  
Department of Psychiatry  
University of California Medical School,  
San Francisco*
- Nicole Belmont  
*Curriculum Director  
Ecole des hautes études en sciences  
socials*
- Jalil Bennani  
*Psychiatrist-Psychoanalyst  
Rabat, Morocco*
- Jean Bergeret, M.D., Ph.D.  
*Psychoanalyst (Société psychanalytique  
de Paris)  
Professor  
University of Lyon II*
- Jean Bergès  
*Neuropsychiatrist  
Psychoanalyst (Association freudienne  
internationale)*
- Bertrand, Michèle  
*Professor  
Université de Franche-Comté  
Psychoanalyst  
Member  
Société psychanalytique de Paris and  
International Psychoanalytical  
Association*
- Elisabeth Bigras  
*Psychiatrist and Psychoanalyst  
Société psychanalytique de Montreal  
and Société canadienne de  
psychanalyse*
- Parthenope Bion Talamo  
*Psychoanalyst*
- Anne Bizot  
*Psychologist and Psychoanalyst*
- Dominique Blin  
*Psychoanalyst and Psychologist*
- Owen Hugh D. Blomfield  
*Member  
Australian Psychoanalytical Society and  
International Psychoanalytical  
Association*
- Geoffrey H. Blowers  
*Senior Lecturer, Director, and P.C.  
Psychiatrist  
University of Hong Kong*
- Harold P. Blum, M.D.  
*Clinical Professor of Psychiatry  
NYU School of Medicine  
Training Analyst  
New York Psychoanalytic Institute  
Member  
International Psychoanalytical  
Association*
- André Bolzinger  
*Doctor, Psychiatrist, and Psychoanalyst  
Member of Evolution psychiatrique  
Member  
Société de psychanalyse freudienne*
- Gérard Bonnet  
*Psychoanalyst  
Member  
Association psychanalytique de France*
- Marc Bonnet  
*Clinical Psychologist  
Analyst-Member  
Quatrième Groupe-O.P.L.F.*
- Bénédicte Bonnet-Vidon  
*Psychiatrist*
- Carlo Bonomi  
*Dr. of Psychology and Dr. of Philosophy  
Training Analyst  
H.S. Sullivan Institute, Florence*
- Jaap Bos  
*Doctor and Psychologist*
- César Botella  
*Psychoanalyst  
Titular Member  
Société psychanalytique de Paris  
Member  
International Psychoanalytical  
Association*
- Sára Botella  
*Psychoanalyst  
Titular Member  
Société psychanalytique de Paris  
Member  
International Psychoanalytical  
Association*
- Pierre Bourdier  
*Psychiatrist and Psychoanalyst  
Titular Member  
Société psychanalytique de Paris*
- Jean-Pierre Bourgeron  
*Member  
Société psychanalytique de Paris*
- Pierre-Jean Bouyer  
*Scriptwriter*
- Sylvain Bouyer  
*Psychoanalyst  
Member of Espace analytique*
- Eva Brabant-Gero  
*Psychoanalyst, Historian*
- Alain Braconier  
*Doctor, Psychiatrist, and Psychoanalyst  
Association psychanalytique de France*
- Charles Brenner  
*Training Analyst  
New York Psychoanalytic Institute*

- Former President*  
*American Psychoanalytic Association*
- Jean-Louis Brenot  
*Member*  
*Société psychanalytique de Paris*
- Yvon Brès  
*Professor Emeritus*  
*Université de Paris-VII*
- Françoise Brette  
*Titular Member*  
*Société psychanalytique de Paris*
- Christien Brinkgreve  
*Professor, Doctor, and Sociologist*
- Danièle Brun  
*Psychoanalyst*  
*Professor*  
*Université de Paris-VII*  
*Member of Espace analytique*
- Roger Bruyeron  
*Aggregated Philosopher*
- Wilhelm Burian  
*Psychiatrist*  
*Member and Training Analyst*  
*Vienna Psychoanalytical Society*
- Claude Bursztein  
*Psychiatrist and Psychoanalyst*  
*Professor of Psychiatry*  
*Université Louis-Pasteur*
- Monique Bydlowski  
*Psychiatrist and Psychoanalyst*  
*Director of Research INSERM*
- Raymond Cahn  
*Titular Member and former President*  
*Société psychanalytique de Paris*
- Jean-Pierre Caillot  
*Psychiatrist*  
*Member*  
*Société psychanalytique de Paris*
- Drina Candilis-Huisman  
*Psychologist*
- Jacqueline Carroy  
*Curriculum Director*  
*École des hautes études en sciences sociales (EHESS)*
- Marie-France Castarède  
*Doctor in Letters and Human Sciences*  
*Université de Paris-V*
- Odile Cazas  
*Psychiatrist and Psychotherapist*
- Roberto Paulo Ceccarelli  
*Psychologist and Psychoanalyst*
- Henri Cesbron Lavau  
*Psychoanalyst*  
*Member*  
*Association freudienne internationale*
- Fidias R. Cesio  
*Doctor and Psychoanalyst*  
*Titular and Training Member*  
*Asociación Psicoanalítica Argentina*
- Josiane Chambrier  
*Psychiatrist and Psychoanalyst*  
*Member*  
*Société psychanalytique de Paris*
- Ghyslain Charron  
*Psychoanalyst*
- Jean-Pierre Chartier  
*Psychoanalyst*  
*Member*  
*Quatrième Groupe-O.L.P.F.*
- Colette Chiland  
*Professor Emeritus of Clinical Psychology*  
*Université de Paris-V*  
*Titular Member*  
*Société psychanalytique de Paris*
- Joan Chodorow, Ph.D.  
*Analyst Member*  
*C. G. Jung Institute of San Francisco*
- Mario Cifali  
*Psychoanalyst*  
*Geneva, Switzerland*
- Mireille Cifali  
*Professor*  
*Université de Genève*
- Francis Clark-Lowes  
*B.S. (Sociology), London University*  
*M.A. (Psychology, Therapy, and Counseling)*
- Geoffrey Cocks  
*Royal G. Hall Professor of History*  
*Albion College, Michigan*
- François Compan  
*Psychiatrist and Psychoanalyst*  
*President*  
*Société française de psychologie individuelle*
- Marco Conci, M.D.  
*Assistant Professor of Psychiatry*  
*Brescia School of Medicine*
- Psychiatric Associate*  
*American Academy of Psychoanalysis*
- Jacqueline Cosnier  
*D.E.S. in Philosophy*  
*Member*  
*Société psychanalytique de Paris*
- Jean Cournut  
*Titular Member*  
*Société psychanalytique de Paris*
- Johannes Cremerius, M.D.  
*Psychiatrist*  
*Member*  
*Deutsche Psychoanalytische Vereinigung*
- Laurence Croix  
*Psychoanalyst and Doctor in Psychology*  
*Université de Paris-V and XIII*
- Boris Cyrulnik  
*Director of Ethological Studies*  
*Faculty of Medicine, Marseille*
- Roger Dadoun  
*Professor Emeritus*  
*Université de Paris-VII*  
*Writer and Philosopher*
- Laurent Danon-Boileau  
*Professor*  
*Université de Paris-V*
- Marc Darmon  
*Psychiatrist and Psychoanalyst*  
*Member*  
*Association freudienne internationale*
- Corinne Daubigny  
*Psychoanalyst*
- Didier David  
*Pediatric Psychiatrist*
- Patrick De Neuter  
*Member*  
*Association freudienne internationale*
- Betty De Shong Meador, Ph.D.  
*Analyst Member*  
*C. G. Jung Institute, San Francisco*
- Rosine Debray  
*Psychoanalyst*  
*Professor of Clinical Psychology*  
*Université de Paris-V*
- Simone Decobert  
*Pediatric Psychiatrist and Psychoanalyst*  
*Titular Member*  
*Société psychanalytique de Paris*

- Bernard Defontaine  
*Psychoanalyst (Société psychanalytique de Paris)*  
*Psychotherapist*  
*Institut Edouard-Claparède de Neuilly*
- Geneviève Delaisi De Parseval  
*Psychoanalyst*
- Patrick Delaroché  
*Psychoanalyst*  
*Former Member*  
*École freudienne de Paris*  
*Member of Espace Analytique*
- Claude Delay-Tubiana  
*Psychoanalyst and Writer*  
*Member*  
*Société psychanalytique de Paris*
- Pierre Delion  
*Psychiatrist*  
*Angers, France*
- Michel Demangeat  
*Psychiatrist and Psychoanalyst*  
*Former Member*  
*École freudienne de Paris*
- Paul Denis  
*Member*  
*Société psychanalytique de Paris*
- Jean-Paul Descombey  
*Psychoanalyst*  
*Member*  
*Société psychanalytique de Paris*  
*Chief Doctor*  
*Centre Henri-Rousselle (Saint-Anne, Paris)*
- Maurice Despinoy  
*Hospital Practitioner*  
*Marseilles*
- Catherine Desprats-Péquignot  
*Psychoanalyst*  
*Lecturer*  
*Université de Paris-VII*  
*Member*  
*Association freudienne internationale*
- Jean-Baptiste Déthieux  
*Psychiatrist*
- Dominique Deyon  
*Psychiatrist and Psychoanalyst*
- Hans Dieckmann  
*Doctor and Training Analyst*  
*C. G. Jung Institute, Berlin*
- Françoise Diot  
*Psychiatrist, Psychoanalyst, and Family Therapist*
- Nicolas Dissez  
*Psychiatrist*
- Karin A. Ditrich, Ph.D., Psy.D.  
*Psychoanalyst*  
*Munich*
- Takeo Doi, M.D.  
*Psychiatrist*  
*Member and Training Analyst*  
*Japan Psychoanalytic Society*
- Jean-Luc Donnet  
*Psychoanalyst*  
*Titular Member*  
*Société psychanalytique de Paris*
- Joël Dor  
*Lecturer and Director of Resesarch at the U.F.R.*  
*Université de Paris-VII*  
*Member of Espace analytique*
- Robert Doria-Median, Jr.  
*Doctor*  
*Titular Member and Training Analyst*  
*Asociación psicoanalítica Argentina*
- François Dosse  
*Historian*  
*Co-animator of Espaces Temps*
- George Downing  
*Psychologist and Clinical Supervisor*  
*Pitié-Salpêtrière*
- Claire Doz-Schiff  
*Doctor of Clinicial Psychology*  
*Centre psycho-pédagogique Claude-Bernard*
- Francis Drossart  
*Psychiatrist and Psychoanalyst*
- Antoine Ducret  
*Psychiatrist and Psychoanalyst*
- François Duparc  
*Titular Member*  
*Société psychanalytique de Paris*  
*President*  
*Groupe lyonnais de psychanalyse*
- Susana Beatriz Dupetit  
*Doctor, Psychiatrist, and Psychoanalyst*  
*Member*  
*Buenos Aires Psychoanalytic Association*
- Judith Dupont  
*Doctor and Psychoanalyst*  
*Associate Member*  
*Association psychanalytique de France*
- François Duyckaerts, Ph.D.  
*Professor Emeritus*  
*Universités de Liège et Bruxelles*  
*Psychoanalyst*
- Alberto Eiguer  
*Psychiatrist and Psychoanalyst*  
*Member*  
*Société psychanalytique de Paris*
- Cláudio Laks Eizirik, M.D., Ph.D.  
*Member and Training Analyst*  
*Sociedade Psicanalítica de Porto Alegre*
- Eugène Enriquez  
*Professor Emeritus of Sociology*  
*Université de Paris-VII*
- R. Horacio Etchegoyen  
*Doctor*  
*Titular Member, Training Analyst, and Past President*  
*Asociación Psioanalítica de Buenos Aires*  
*Past President*  
*International Psychoanalytical Association*
- Bertrand Etienne  
*Psychiatrist*  
*ASM 12*
- Haydée Faimberg  
*Doctor and Psychoanalyst*  
*Titular Member*  
*Société psychanalytique de Paris*
- Grazia Maria Fava Vizziello  
*Professor of Psychopathology*  
*University of Padua*
- Luis Féder, Psy.D., M.Psy, B.A.  
*Founding Member*  
*Asociación Psicoanalítica de Mexico*  
*Training and Supervising*  
*Psychoanalyst*  
*Academy of Medical Sciences,*  
*Instituto Mexicano de cultura*
- Ernst Federn  
*Social work therapist in the U.S. (1948–1972)*  
*Social therapist with the Austrian correctional system (1972–)*
- Pierre Ferrari  
*Professor of Child Psychiatry and Psychoanalyst*
- Alain Fine  
*Doctor and Psychoanalyst*

- Member*  
*Société psychanalytique de Paris*
- Eugenie Fischer, M.D.  
*Psychiatrist and Psychoanalyst*  
*Member*  
*Deutsche Psychoanalytische*  
*Vereinigung and the International*  
*Psychoanalytical Association*
- René Fischer, M.D.  
*Psychoanalyst*  
*Deutsche Psychoanalytische Vereinigung*  
*and International Psychoanalytical*  
*Association*
- Margaret Ann Fitzpatrick Hanly, Ph.D.  
*Psychoanalyst*  
*Member*  
*Canadian Psychoanalytic Society*  
*Member*  
*Toronto Psychoanalytic Institute*
- Olivier Flournoy, M.D.  
*Psychiatrist and Psychoanalyst*  
*Université de Lausanne*
- Josette Frappier  
*Psychoanalyst*  
*Member*  
*Société psychanalytique de Paris*
- Annette Fréjaville  
*Psychiatrist and Psychoanalyst*  
*Member*  
*Société psychanalytique de Paris*
- Marguerite Frémont  
*Assistant to Dr. René Allendy*  
*(1932–1942)*
- Anne Frichet  
*Clinical Psychologist*  
*Centre de guidance infantile (Paris)*
- Serge Frisch  
*Psychiatrist*  
*Psychoanalyst (Belgian Society)*  
*Former President*  
*EFPP*
- Manuel Furer  
*Training Analyst and Supervisor*  
*New York Psychoanalytic Institute*
- Robert A. Furman, M.D.  
*Psychoanalyst*  
*Training Analyst*  
*Cleveland Psychoanalytic Institute*
- Glen O. Gabbard, M.D.  
*Director*
- Baylor Psychiatry Clinic*  
*Training Analyst and Supervisor*  
*Houston/Galveston Psychoanalytic*  
*Institute*
- Christian Gaillard  
*Professor, Psychologist, and Psychoanalyst*
- Yolanda Gampel  
*Training Analyst*  
*Israeli Psychoanalytic Society*  
*Professor*  
*Tel Aviv University*
- Gerald J. Gargiulo  
*Psychoanalyst*  
*Fellow at IPTAR*  
*Member*  
*International Psychoanalytical*  
*Association*
- Josette Garon  
*Psychoanalyst*  
*Member*  
*Canadian Psychoanalytic Society*
- Jean Garrabé  
*Psychiatrist*  
*President*  
*Evolution psychiatrique*
- Lilli Gast, Ph.D.  
*Psychologist*  
*Freiberufliche Wissenschaftlerin, Berlin*
- Serge Gauthier  
*Psychiatrist and Psychoanalyst*
- Yvon Gauthier  
*Doctor, Pediatric Psychiatrist, and*  
*Psychoanalyst*  
*Member*  
*Canadian Psychoanalytic Society*
- Marcelle Geber  
*Pediatric Psychiatrist and Psychoanalyst*
- Nicole Geblesco  
*Psychoanalyst*  
*Member*  
*Société internationale de poïétique*
- Claudine Geissmann  
*Psychiatrist*  
*Curriculum Director*  
*Université Victor-Segalen Bordeaux-II*  
*Member*  
*Association psychanalytique de France*
- Christopher Gelber, Ph.D.  
*Psychologist and Psychoanalyst*
- Alain Gibeault  
*Titular Member*
- Société psychanalytique de Paris*  
*Secretary General*  
*International Psychoanalytical*  
*Association*
- Sanford Gifford, M.D.  
*Director of Archives*  
*Boston Psychoanalytic Society and*  
*Institute*
- Irma Gleiss, Ph.D.  
*Psychoanalyst*
- Martin J. Gliserman, Ph.D.  
*Psychoanalyst, (NAAP-certified)*
- Arnold I. Goldberg, M.D.  
*Professor of Psychiatry*  
*Rush Medical School*
- Bernard Golse  
*Pediatric Psychiatrist and Psychoanalyst*
- Edmundo Gomez Mango  
*Psychoanalyst*
- Roland Gori  
*Psychoanalyst*  
*Professor of Psychopathology*  
*Université d'Aix-Marseille-I*
- Sylvie Gosme-Séguret  
*Psychologist and Psychotherapist*
- Nicolas Gougoulis  
*Psychiatrist, Hospital practitioner, and*  
*Psychoanalyst*  
*Member*  
*Société psychanalytique de Paris*
- Giancarlo Gramaglia  
*Psychoanalyst*  
*Torino, Italy*
- André Green  
*Doctor, Psychiatrist, and Psychoanalyst*  
*Past President*  
*International Psychoanalytical*  
*Association*  
*Past President*  
*Société psychanalytique de Paris*
- Daniel Greenson  
*Physician and Psychoanalyst*
- Léon Grinberg  
*Training Analyst*  
*Psychoanalytic Association of Madrid*
- Marie-Laure Grivet-Shillito  
*Doctor of Psychoanalysis and*  
*Psychopathology*  
*Member*

- International Society of Psychoanalytic Psychology*  
 Han Groen-Prakken, M.D.  
*Full Member and Training Analyst  
 Dutch Psychoanalytic Society*
- Helmut Gröger  
*Art and Medical Historian  
 Assistant Professor and Lecturer  
 Institut fuer Geschichte der medizien der  
 Universitaet Wien*
- James S. Grotstein, M.D.  
*Clinical Professor of Psychology  
 School of Medicine at the University of  
 California, Los Angeles  
 Psychoanalyst  
 Past Vice-President  
 International Psychoanalytical  
 Association*
- Hungarian Group  
*Gábor Flaskay, M.D.  
 Gyoergy Hidas, M.D.  
 Livia Nemes, Ph.D. (pdt)  
 Gyoergy Vikar, M.D.*
- Ilse Grubrich-Simitis  
*Psychoanalyst  
 Member  
 International Psychoanalytical  
 Association  
 Training Analyst and Supervisor  
 German Psychoanalytic Association*
- Antoine Guédéney  
*Psychiatrist and Psychoanalyst  
 Member  
 Société psychanalytique de Paris*
- Nicole Guédéney  
*Child Psychiatrist*
- Jean-Claude Guillaume  
*Pediatric Psychiatrist-Psychoanalyst*
- Christiane Guitard-Munnich  
*Doctor, Psychiatrist, and  
 Psychoanalyst  
 Member  
 Société psychanalytique de Paris*
- José Gutiérrez Terrazas  
*Psychoanalyst  
 Titular Member  
 Universidad Autonoma de Madrid  
 Member  
 Asociación Psicoanálisis de Madrid*
- Geneviève Haag  
*Psychiatrist and Psychoanalyst*
- Member  
 Société psychanalytique de Paris*
- Gisèle Harrus-Revidi  
*Member  
 Société psychanalytique de Paris*
- Lawrence Hartmann, M.D.  
*Past President  
 American Psychiatric Association*
- Marc Hayat  
*Psychiatrist and Psychoanalyst  
 Past President  
 Association Ecart*
- Anne Hayman  
*Psychiatrist and Psychoanalyst  
 Member  
 British Psycho-Analytical Society  
 Archivist  
 International Psychoanalytical  
 Association*
- Joseph L. Henderson  
*Training Analyst and Past President  
 C. G. Jung Institute in San Francisco*
- Ludger M. Hermanns  
*Psychoanalyst  
 Member  
 German Psychoanalytic Association  
 Lecturer and Honorary Archivist  
 Karl Abraham Institute of Berlin*
- Fabio Herrmann, M.D.  
*Titular Member and Training  
 Analyst  
 Sociedade Brasileira de Psicanalise de  
 Sao Paolo*
- Jean-Paul Hiltenbrand  
*Psychiatrist and Psychoanalyst  
 Member  
 Association freudienne internationale*
- Robert D. Hinshelwood  
*Member  
 British Psychoanalytical Society*
- Albrecht Hirschmuller  
*Consultant Psychiatrist and Neurologist  
 Psychotherapist*
- Jean-Michel Hirt  
*Psychoanalyst  
 Lecturer in Psychopathology  
 Université de Paris-Nord*
- Leon Hoffman, M.D.  
*Training and Supervising Analyst  
 New York Psychoanalytic Institute*
- Robert R. Holt  
*Psychologist  
 Founding director  
 Research Center for Mental Health  
 Professor of Psychology Emeritus  
 New York University*
- James R. Hood, M.D.  
*MBCHM Glas and MRC Psychology  
 Member  
 British Psychoanalytical Society*
- Anne-Marie Houdebine  
*Psychoanalyst and Doctor of Letters and  
 Human Sciences  
 Professor of Linguistics and Semiology  
 Université René Descartes, Paris-V*
- Marcel Houser  
*Doctor and Psychoanalyst  
 Member  
 Société psychanalytique de Paris*
- Florian Houssier  
*Psychologist and Psychotherapist  
 Research Professor  
 Université de Paris-VII*
- Didier Houzel  
*Pediatric Psychiatrist and  
 Psychoanalyst  
 Member  
 Association psychanalytique de France*
- Patrice Huerre  
*Psychiatrist  
 Medical Director  
 University Medical Clinic Georges-  
 Heuyer (Paris)*
- Athol Hughes, Ph.D.  
*Member  
 British Psychoanalytical Society*
- Andrea Hupke, Psy.D.  
*Independent Scholar*
- Marvin S. Hurvich, Ph.D.  
*Professor of Psychology  
 Long Island University*
- Melvyn L. Iscove  
*Fellow  
 Royal College of Physicians (Canada)*
- Benjamin Jacobi  
*Psychologist and Psychoanalyst  
 Lecturer  
 University Medical Clinic  
 Georges-Heuyer, Université de  
 Provence*



- Mario Jacoby, Ph.D.  
*Faculty, Board of Directors (Curatorium),  
and Training and Supervising Analyst  
C. G. Jung Institute in Zurich*
- Frédérique Jacquemain  
*Pediatric Psychiatrist*
- Nicole Jeammet  
*Lecturer in Psychopathology  
Université de Paris-V*
- Philippe Jeammet  
*Psychiatrist and Psychoanalyst  
Professor of Psychiatry  
Université de Paris-VI*
- Alban Jeanneau  
*Psychiatrist*
- Augustin Jeanneau  
*Psychiatrist  
Titular Member  
Société psychanalytique de Paris*
- Per Magnus Johansson  
*Psychoanalyst and Doctor in the History  
of Science*
- Jennier Johns  
*Physician and Psychoanalyst  
Member  
British Psychoanalytical Society*
- Marcus Johns, M.D.  
*Child and Family Psychiatrist  
Member  
British Psychoanalytical Society*
- Juan Francisco Jordan Moore  
*Psychiatrist  
Past President, Titular Member, and  
Training Analyst  
Asociación Psicoanálisis Chilena*
- Rosine Jozef Perelberg, Ph.D.  
*Training Analyst  
British Psychoanalyst Society*
- Marie Eugénie Jullian Muzzo  
Benavides  
*Psychoanalyst and Psychologist  
Member  
Société psychanalytique de Paris*
- René Kaës  
*Psychoanalyst  
Professor Emeritus  
Université Lumière Lyon-II*
- Sudhir Kakar  
*Professor and Doctor*
- Jean-Pierre Kamieniak  
*Psychoanalyst*
- Lecturer  
Université de Rouen*
- Vassilis Kapsambelis  
*Psychiatrist and Psychoanalyst*
- Verena Kast  
*Professor of Psychology  
University of Zurich  
Training Analyst  
C. G. Jung Institute in Zurich*
- Kathleen Kelley-Lainé  
*Psychoanalyst  
Member  
Société psychanalytique de Paris*
- Christine de Kerchove  
*Psychologist and Psychoanalyst  
Member  
Société psychanalytique de Paris*
- Otto F. Kernberg, M.D.  
*Director  
Personality Disorders Institute, New  
York Presbyterian Hospital, Cornell  
University  
Professor of Psychiatry  
Cornell University (Westchester)  
Training and Supervising Analyst  
Columbia University Center for Psycho-  
analytic Training and Research*
- Moisés Kijak  
*Doctor  
Titular Member and Training Analyst  
Asociación Psicoanálisis de Argentina*
- Pearl H. M. King  
*Psychoanalyst  
Member  
British Psychoanalytical Society*
- Simon-Daniel Kipman  
*Past President  
Association française de psychiatrie*
- Jean Kirsch, M.D.  
*Past President  
C. G. Jung Institute in San Francisco  
Member  
International Psychoanalytical  
Association*
- Thomas Kirsch, M.D.  
*Psychiatric Training  
Stanford University  
Diplomat  
C. G. Jung Institute in San Francisco*
- Maïté Klahr  
*Psychologist-Psychoanalyst*
- Saint-Vincent-de-Paul Hospital,  
Paris*
- Ruth Kloocke, M.D.  
*Independent Scholar*
- Léon Kreisler  
*Pediatric Doctor and Psychiatrist  
Co-founder  
Institut de psychosomatique (Paris)*
- Nicolle Kress-Rosen  
*Psychoanalyst  
DESS in Psychology (Spain)*
- Julia Kristeva  
*Psychoanalyst  
Member  
Société psychanalytique de Paris  
Professor in Linguistics  
Université de Paris-VII  
Permanent Visiting Professor, Depart-  
ment of French  
Columbia University and at the Univer-  
sity of Toronto*
- Nora Kurts  
*Psychologist  
Psychoanalyst Member  
Société psychanalytique de Paris*
- Edith Kurzweil  
*University Professor and Director  
Center for Humanities and Social  
Thought at Adelphi University*
- Marie-Lise Lacas  
*Neuropsychiatrist and Psychoanalyst  
Member  
Société psychanalytique de Paris*
- Eva Laible  
*Doctor  
Member  
Vienna Psychoanalytic Society*
- Michael Laier, M.D.  
*Medical Historian  
Senckenbergischen Institut fuer Medizin  
der Universitaet Frankfurt*
- Marie Claire Lanctôt Bélanger  
*Philosopher and Psychoanalyst  
Member  
Société psychanalytique de Paris of  
Montréal and Société canadienne de  
psychanalyse*
- Jean-Louis Lang  
*Former Head  
Clinical Faculty at Université de  
Paris-VII*

- Jacqueline Lanouzière  
*Doctor of Letters and Human Sciences*  
*Professor Emeritus of Psychopathology*  
*Université de Paris-XIII*  
*Member*  
*Société psychanalytique de Paris*
- Georges Lantéri-Laura  
*Honorary Chief*  
*Esquirol Hospital*  
*Honorary President*  
*Evolution psychiatrique*
- Jean Laplanche  
*Titular Member*  
*Association psychanalytique de France*
- Moses Laufer, Ph.D.  
*Past President*  
*British Psychoanalytical Society*
- Jacques Launay  
*Past President*  
*Groupe Internationale du Rêve éveillé en psychanalyse*
- Marie-Christine Laznik  
*Psychoanalyst*  
*Member*  
*Bureau de l'Association freudienne internationale*
- Serge Lebovici  
*Pediatric Psychiatrist*  
*Titular Member*  
*Société psychanalytique de Paris*  
*Past President*  
*International Psychoanalytical Association*
- David D. Lee, Ph.D.  
*Independent Scholar*
- Bernard Lemaigre  
*Affiliated Member*  
*Société psychanalytique de Paris*
- Brigitte Lemérier  
*Psychoanalyst*  
*Former Member*  
*École freudienne de Paris*
- Moisés Lemlij, M.D., DPM, MRC  
*Training Analyst and Titular Member*  
*Sociedad Peruana de Psicoanálisis*
- Martine Lerude  
*Psychiatrist and Psychoanalyst*  
*Member*  
*Association freudienne internationale*
- Odile Lesourne, Ph.D.  
*Psychoanalyst*
- Harald Leupold-Löwenthal  
*Psychoanalyst*  
*Member*  
*Vienna Psychoanalytic Society*
- Ghyslain Levy  
*Psychoanalyst*  
*Member*  
*Quatrième Groupe-O.P.L.F.*
- E. James Lieberman  
*Clinical Professor of Psychiatry*  
*George Washington University*
- Roy K. Lilleksov, M.D.  
*Independent Scholar*
- Regine Lockot, Ph.D.  
*Psychoanalyst*
- Hans-Martin Lohmann  
*Lecturer, Editor, and Author*
- Pearl Lombard  
*Psychiatrist*  
*Titular Member*  
*Société psychanalytique de Paris*
- Rafael E. López-Corvo  
*Associate Professor*  
*Mc Gill University*  
*Training Analyst*  
*Asociación Venezola de Psicoanálisis*
- Zvi Lothane, M.D.  
*Clinical Associate Professor of Psychiatry*  
*Mount Sinai School of Medicine, CUNY*
- Gérard Lucas  
*Psychiatrist AIHP*  
*Member*  
*Société psychanalytique de Paris*
- Daniel Luminet  
*Psychiatrist and Psychoanalyst*  
*Member*  
*Société psychanalytique de Belge*  
*Honorary Professor*  
*Université de Liège*
- André Lussier  
*Doctor in Psychology*  
*Former Titular Professor*  
*Université de Montréal*  
*Former Vice President*  
*International Psychoanalytical Association*
- Elfriede S. Lustig de Ferrer, M.D.  
*Full Member*  
*Asociación Psicoanálisis Argentina and International Psychoanalytical Association*  
*Training Analyst and Past Vice President*  
*International Psychoanalytical Association*
- Pedro Luzes  
*Professor of Clinical Psychology*  
*University of Lisbon*
- Veronica Mächtlinger  
*Dip. Clin. Psychology (London)*
- Patrick J. Mahony, Ph.D.  
*Member*  
*Société royale du Canada*  
*Training Analyst*  
*Société canadienne de psychanalyse*
- Anne-Marie Mairesse  
*Lecturer in Clinical Psychology*  
*Psychoanalyst (Société psychanalytique de Paris)*
- Irina Manson  
*Psychoanalyst*  
*Vice President*  
*Pérénos*
- Lydia Marinelli  
*Cultural Historian*  
*Archivist at the Freud Museum, Vienna*
- Philippe Mazet  
*Professor of Psychiatry*  
*AP-HP, Paris*
- Joyce McDougall  
*D.Ed. and Titular Member*  
*Société psychanalytique de Paris*  
*Full Member*  
*International Psychoanalytical Association*  
*Member*  
*New York Freudian Society*
- Philippine Mefre  
*Psychologist and Psychotherapist*
- Charles Melman  
*Former Hospital Psychiatrist*  
*Former Director of Scilicet*  
*Founder*  
*Association freudienne internationale*
- Ruth Menahem  
*Director of Research at the CNRS*

- Psychoanalyst*  
*Member*  
*Société psychanalytique de Paris*
- Rosario Merendino  
*Psychoanalyst*  
*Member*  
*Società Psicoanalitica Italiana*
- Nadine Mespoulhès  
*Psychotherapist-Psychoanalyst*
- Philippe Metello  
*Pediatric Psychiatrist*
- André Michel  
*Writer*  
*Honorary Professor of Classical Letters*
- Pascale Michon-Raffaitin  
*Psychiatrist and Psychoanalyst*
- Alain de Mijolla  
*Neuropsychiatrist and Psychoanalyst*  
*Titular Member*  
*Société psychanalytique de Paris*  
*President*  
*International Association for the History*  
*of Psychoanalysis*  
*Member*  
*International Psychoanalytical Association*
- Sophie de Mijolla-Mellor  
*Psychoanalyst*  
*Professor of Psychopathology*  
*Université de Paris-VII*  
*Member*  
*Quatrième Groupe-O.P.L.F.*
- Alexandre Mikhalevitch  
*Doctor of Psychoanalysis*  
*Université de Paris-VII*
- Claude Millot  
*Psychologist-Psychoanalyst*
- Bernard Minder, M.D.  
*Psychiatrist*
- André Missenard  
*Psychoanalyst and Psychiatrist*  
*Quatrième Groupe-O.P.L.F.*
- Sylvain Missonnier  
*Lecturer in Psychology*  
*Université de Paris-X, Nanterre*
- Jeanne Moll, M.A., German, DESS  
*IUFM, Alsace*
- Michael Molnar  
*Research Director*  
*Freud Museum, London*
- Marie-Thérèse Montagnier  
*Psychoanalyst*  
*Titular Member*  
*Société psychanalytique de Paris*
- Michelle Moreau Ricaud  
*Psychoanalyst*  
*Member*  
*Quatrième Groupe-O.P.L.F.*
- Ann Morgan  
*Private Practice*  
*Melbourne*
- Marie-Rose Moro  
*Child Psychiatrist and Psychoanalyst*
- Peter Mudd  
*Jungian Psychoanalyst*
- Elke Mühlleitner, Ph.D.  
*Psychologist*  
*Researcher, History of Psychoanalysis*
- Laurent Muldworf, M.D.  
*Psychiatrist*
- María Luisa Muñoz  
*Training Analyst*  
*Asociación Psicoanálisis de Madrid*
- Martine Myquel  
*Professor of Pediatric Psychiatry*  
*Member*  
*Société psychanalytique de Paris*
- Marie-Thérèse Neyraut-Sutterman  
*Psychiatrist, DESS, and Psychoanalyst*  
*Member*  
*Société psychanalytique de Paris*
- Nicos Nicolaïdis  
*Doctor*  
*Titular Member*  
*Société Suisse de Psychanalyse*
- Bernd Nitzschke, PsyD., Ph.D.  
*Psychoanalyst*
- Janine Noël  
*Consultant Psychiatrist*  
*C.O.P.E.S.*  
*Member*  
*Société psychanalytique de Paris*
- Leopold Nosek, M.D.  
*Training Analyst and Past President*  
*Brazilian Psychoanalytic Society*
- Valentin Nusinovic  
*Psychoanalyst*  
*Member*  
*Association freudienne internationale*
- Edna O'Shaughnessy  
*Training Analyst*  
*British Psychoanalytical Society*
- Michel Ody  
*Psychoanalyst*  
*Titular Member*  
*Société psychanalytique de Paris*
- Annick Ohayon  
*Psychology Instructor*  
*Université de Paris-VIII*
- Keigo Okonogi, M.D.  
*Training Analyst*  
*Japan Psychoanalytic Society*
- Ole Andkjaer Olsen, Ph.D.  
*Senior Research Worker and Writer*
- Agnès Oppenheimer  
*Lecturer in Psychopathology*  
*Université de Paris-V*
- Francisco Palacio Espasa  
*Ordinary Member*  
*Société Suisse de Psychanalyse*
- Renos K. Papadopoulos  
*Professor of Analytical Psychology*  
*University of Essex*
- Bernard J. Paris, Ph.D.  
*Director*  
*International Karen Horney Society*
- Mark Paterson  
*Director*  
*Sigmund Freud Copyrights*
- Campbell Paul  
*Consultant Infant Psychiatrist*  
*Royal Children's Hospital, Melbourne*
- Christiane Payan  
*Pediatric Psychiatrist*
- Bernard Penot  
*Psychiatrist and Psychoanalyst*  
*Titular Member*  
*Société psychanalytique de Paris*
- René Péran  
*Doctor, Psychiatrist, and Psychoanalyst*  
*Member*  
*Quatrième Groupe-O.P.L.F.*
- Marialzira Perestrello  
*Doctor, Psychoanalyst, and Poet*  
*Pioneer of Psychoanalysis in Rio de Janeiro*
- Roger Perron  
*Honorary Director of Research*

- National Center for Scientific Research,  
Paris  
Former Director of Research  
Université de Paris-V*
- Christine Petit  
*Psychiatrist and Hospital Practitioner*
- Augusto M. Picollo  
*Titular Member and Training Analyst  
Asociación Psicoanálisis Argentina*
- Malcolm Pines  
*Bachelor of Medicine and Surgery  
(Cambridge)  
Fellow  
Royal College of Physicians (London)  
Fellow  
Royal College of Psychiatrists*
- Monique Piñol-Douriez  
*Member  
Société psychanalytique de Paris  
Professor Emeritus  
Université de Provence*
- Tomas Plänklers, Ph.D., Psy.D.  
*Psychoanalyst*
- Michèle Pollak Cornillot  
*Lecturer  
Université de Paris-V*
- Michel Polo  
*Psychoanalyst  
Member  
Espace analytique*
- Pontalis, Jean-Bertrand  
*Titular Member  
Association psychanalytique de France  
Series Editor at Éditions Gallimard  
Writer*
- Erik Porge  
*Psychoanalyst  
Former Member  
École freudienne de Paris*
- Michèle Porte  
*Psychoanalyst and Psychotherapist  
Paul-Brosse Hospital  
Instructor  
École Normale Supérieure*
- Anna Potamianou, Ph.D.  
*Psychoanalyst  
Training Analyst  
Société psychanalytique de Paris*
- Luiz Eduardo Prado de Oliveira  
*Doctor of Clinical Psychology*
- Member  
Sociedade de Psicanálise Iracy Doyle-Rio  
de Janiero*
- Régine Prat  
*Psychologist-Psychoanalyst*
- Janine Puget  
*Doctor  
Founding Member  
Argentine Group Therapy Association  
Titular Member  
Buenos Aires Psychoanalytic Association*
- Bertrand Pulman  
*Lecturer, Social Sciences Department  
Université de Paris-V*
- Florence Quartier-Frings  
*Founding Titular Member  
Société Suisse de psychanalyse (International Psychoanalytical Association)*
- Jean-Michel Quinodoz  
*Titular Member and Training Analyst  
Société Suisse de psychanalyse*
- Didier Rabain  
*Pediatric Psychiatrist  
Salpêtrière Hospital*
- Jean-François Rabain  
*Psychiatrist and Psychoanalyst  
Titular Member  
Société psychanalytique de Paris*
- Nicholas Rand  
*Professor of French Literature and  
Senior Research Fellow  
University of Wisconsin-Madison*
- Helene Rank-Veltfort, Ph.D.  
*Psychotherapist  
ex-teacher at the Proctorship Committee  
Mills-Peninsula Hospital*
- Jean-Jacques Rassial  
*Professor of Psychopathology  
Université de Paris-XIII  
Member of Espace analytique*
- Gail S. Reed, Ph.D.  
*Training and Supervising Analyst  
New York Freudian Society*
- Johann Georg Reicheneder  
*Doctor*
- Owen Renik  
*Training and Supervising Analyst  
San Francisco Psychoanalytic Institute  
Associate Editor  
The Psychoanalytic Quarterly*
- Joseph Reppen, Ph.D.  
*Editor  
Psychoanalytic Books  
Member  
International Psychoanalytical Association  
New York Freudian Society*
- Alvaro Rey de Castro  
*Psychoanalyst  
Professor  
Catholic University of Peru  
Titular Member and Past President  
Sociedad Peruana de Psicoanálisis*
- Denys Ribas  
*Doctor  
Titular Member  
Société psychanalytique de Paris*
- François Richard  
*Psychologist and Psychoanalyst  
Professor of Psychopathology  
Université de Paris-VII*
- Arnold D. Richards, M.D.  
*Training and Supervising Analyst  
New York Psychoanalytic Institute*
- Paul Ries, M.A., Ph.D.  
*University Lecturer, Faculty of Modern  
and Medieval Languages  
University of Cambridge  
Psychoanalytic-Psychotherapist*
- Paul Roazen  
*Professor Emeritus, Social and Political  
Science  
York University (Toronto)*
- Thomas Robert  
*Archivist  
Sigmund Freud Copyrights*
- Anne Roche  
*Former student at the École Normale  
Supérieure  
Professor  
Université de Provence*
- Eva Rosenblum  
*Psychoanalyst, Paris  
Research Attache  
CNRS*
- David Rosenfeld  
*Doctor  
Training Analyst  
Professor of Mental Health, Faculty of  
Medicine  
University of Buenos Aires*

- Hans-Joachim Rothe, M.D.  
*Independent Scholar*
- René Roussillon  
*Professor*  
*Université Lyon-II*  
*Titular Member*  
*Société psychanalytique de Paris*
- Marie-Lise Roux  
*Titular Member*  
*Société psychanalytique de Paris*
- August Ruhs  
*Psychiatrist and Psychoanalyst*  
*Wiener Arbeitskreis für Psychoanalyse*
- Pierre Sabourin  
*Psychiatrist and Psychoanalyst*
- Gilda Sabsay Foks  
*Psychiatrist and Psychoanalyst*  
*(Argentina)*  
*Titular Member*  
*Argentine Psychoanalytic Association*
- François Sacco  
*Psychiatrist and Psychoanalyst*  
*Member*  
*Société psychanalytique de Paris*
- Eduardo J. Salas  
*Doctor*  
*Psychiatrist and Psychoanalyst*  
*Training Analyst*  
*Argentine Psychoanalytic Association*
- Isaac Salem  
*Psychiatrist and Psychoanalyst*  
*Member*  
*Société psychanalytique de Paris*
- Andrew Samuels  
*Professor of Analytical Psychology*  
*University of Essex*  
*Training Analyst*  
*Society of Analytical Psychology,*  
*London*
- Guillermo Sanchez Medina  
*Doctor and Psychoanalyst*  
*Titular Member and President*  
*Colombian Psychoanalytic Society*
- Jacqueline Schaeffer  
*Titular Member*  
*Société psychanalytique de Paris*
- Nora Scheimberg  
*Psychologist and Psychoanalyst*
- Delphine Schilton  
*Psychoanalyst*
- Elsa Schmid-Kitsikis  
*Professor of Clinical Psychology*  
*University of Geneva*
- Gérard Schmit  
*Professor of Child Psychiatry and*  
*Psychoanalyst*  
*UFR of Medicine at Reims*
- Monique Schneider  
*Psychoanalyst*  
*Research Director at the CNRS*
- Ingrid Scholz-Strasser  
*General Secretary*  
*Sigmund Freud Society*
- Georges Schopp  
*Psychoclinician and Psychoanalyst*
- Jacques Schotte  
*Psychiatrist-Psychoanalyst*  
*Professor Emeritus of Clinical*  
*Psychology*  
*Universities of Louvain-la-Neuve and*  
*Louvain-Leuven*
- Martin A. Schulman, Ph.D.  
*Editor*  
*Psychoanalytic Review*  
*Former Dean of Faculty and*  
*Curriculum*  
*The National Psychological Association*  
*for Psychoanalysis*
- Ulrich Schultz-Venrath  
*M.D. of Psychotherapeutic Medicine,*  
*Neurology, and Psychiatry*  
*Professor*  
*University Witten/Herdecke*
- Michael Šebek  
*Direct Member*  
*International Psychoanalytical*  
*Association*  
*Training Analyst*  
*Czech Study Group*
- Jacques Sédat  
*Psychoanalyst*  
*Member of Espace analytique*  
*Secretary General*  
*International Association for the History*  
*of Psychoanalysis*
- Hanna Segal  
*Doctor*  
*Fellow*  
*Royal College of Psychiatry*  
*Training Analyst and Past President*  
*British Psychoanalytic Society*
- Christian Seulin  
*Psychiatrist*  
*Psychoanalyst*  
*Member*  
*Société psychanalytique de Paris*
- Sue A. Shapiro, Ph.D.  
*Supervising Analyst*  
*NYU Postdoctoral Program in Psychoanalysis*
- Robert Shilkret  
*Professor of Psychology and Education*  
*Mount Holyoke College*
- Larry Shiner  
*Professor of Philosophy*  
*University of Illinois at Springfield*
- Joyceline Siksou  
*Psychoanalyst*  
*Member*  
*Société psychanalytique de Paris*
- Ann-Louise S. Silver, M.D.  
*Psychiatrist and Psychoanalyst*  
*Chestnut Lodge/C.P.C. Faculty:*  
*Washington Psychoanalytic Institute*
- John Galbraith Simmons  
*Writer, Screenwriter, and Independent*  
*Scholar*
- Jöel Sipos  
*Psychoanalyst*  
*Member*  
*Institut de formation de l'Association*  
*psychanalytique de France*
- Samuel Slipp, M.D.  
*Past President*  
*American Academy of Psychoanalysis*
- Claude Smadja  
*Doctor, Psychiatrist, and Psychoanalyst*  
*Member*  
*Société psychanalytique de Paris*
- María de Lourdes Soares O'Donnell  
*Doctor and Psychoanalyst*  
*Titular Member*  
*Brazilian Psychoanalytic Society of Rio*  
*de Janeiro*
- Victor Souffir  
*Former Chief Doctor of Psychiatry*  
*Member*  
*Société psychanalytique de Paris*
- Michel Soulé  
*Honorary Professor of Child Psychiatry*  
*Université de Paris-V*  
*Titular Member*  
*Société psychanalytique de Paris*

Ethel Spector Person, M.D.  
*Training and Supervising Analyst*  
*Columbia University Center for Training and Research*

Murray Stein, Ph.D.  
*Training Analyst*  
*C. G. Jung Institute of Chicago*

Riccardo Steiner  
*Psychoanalyst*  
*Member*  
*British Psychoanalytical Society*

Robert D. Stolorow, Ph.D.  
*Training Analyst and Director of Supervision*  
*Institute of Contemporary Psychoanalysis, Los Angeles*

Gunther Stuhlmann  
*Writer*  
*Founder and Editor*  
*Anais: An International Journal*

Guillaume Suréna  
*Orthophonist and Psychoanalyst*

Nina Sutton  
*Writer and journalist*

Henri Sztulman  
*Dean of Professors (Toulouse-II)*  
*Member*  
*Société psychanalytique de Paris*

Jean-Yves Tamet  
*Psychiatrist*  
*Psychoanalyst (Association psychanalytique de France)*

Juan-Eduardo Tesone  
*Doctor, Psychiatrist, and Psychoanalyst*  
*Member*  
*Société psychanalytique de Paris*

Viviane Thibaudier  
*Psychoanalyst*  
*Training Analyst*  
*Société française de psychologie analytique*

Bernard This  
*Psychoanalyst*

Nellie L. Thompson, Ph.D.  
*Psychoanalyst and Historian*  
*Member*  
*New York Psychoanalytical Society*

Serge Tisseron  
*Psychiatrist and Psychoanalyst*

David Titleman  
*Doctor of Psychology*  
*Training Analyst*  
*Swedish Psychoanalytic Society*

Bernard Toboul  
*Psychoanalyst*  
*Member of Espace analytique*  
*Member*  
*International Association for the History of Psychoanalysis*

Margret Tonnesmann, M.D.  
*Psychoanalyst*  
*British Psychoanalytical Society*

Maria Torok  
*Psychoanalyst*  
*Member*  
*Société psychanalytique de Paris*

Bernard Touati  
*Pediatric Psychiatrist and Psychoanalyst*  
*Centre Alfred-Binet*  
*Member*  
*International Association for the History of Psychoanalysis*

Marie-Dominique Trapet  
*Docteur d'Etat in Law and Doctor of Common Law*  
*Psychoanalyst and Magistrate*

David I. Tresan, M.D.  
*Member*  
*C. G. Jung Institute of Northern California*

Hélène Trivouss-Widlöcher  
*Psychoanalyst and Neuropsychiatrist*  
*Titular Member, Association psychanalytique de France*

Philippe Turmond  
*Psychiatrist and Psychoanalyst*

Richard Uhl  
*Psychiatrist*  
*Member*  
*Société psychanalytique de Paris,*

Rodolfo Urribarri  
*Professor*  
*University of Buenos Aires*  
*Member*  
*Argentine Psychoanalytical Society*

Simone Valantin  
*Senior Lecturer*  
*Université de Paris-VII*

*Member*  
*Société psychanalytique de Paris*

Odon Vallet  
*Former student at the ENS*  
*Doctor of Law and Religious Studies*  
*Director of Curriculum*  
*Paris-I and Paris-VII*

Bernard Vandermersch  
*Psychiatrist and Psychoanalyst*  
*Member*  
*Association freudienne internationale*

Alain Vanier  
*Professor*  
*Université de Paris-VII*  
*Psychoanalyst*  
*Member of Espace analytique*

Katia Varenne  
*Psychologist and Psychoanalyst*  
*Titular Member at the EPS*

Sverre Varvin, M.D.  
*Psychoanalyst*  
*President*  
*Norwegian Psychoanalytic Society*

Elizabeth Verhage-Stins  
*Psychologist, Psychoanalyst, and Training Analyst*  
*Amsterdam*

Henri Vermorel  
*Former hospital Psychiatrist and Psychoanalyst*  
*Titular Member*  
*Société psychanalytique de Paris*

Madeleine Vermorel  
*Psychoanalyst*  
*Chambéry*

Bertrand Vichyn  
*Psychoanalyst*  
*Doctor of Psychoanalysis*  
*Instructor*  
*Université de Paris-VII*

Fernando Vidal  
*Université of Geneva*

Jacques Vigneault  
*Sociologist and Psychoanalyst*  
*Member*  
*Société psychanalytique de Montréal*

Joseph Villier  
*Psychoanalyst and Family Therapist*  
*Member*  
*Société psychanalytique de Paris,*

Michel Vincent  
*Psychoanalyst*  
*Titular Member*  
*Société psychanalytique de Paris*

Christine Vindreau  
*Former Chief Clinician,*  
*Psychiatrist, and Hospital*  
*Practitioner*  
*Analyst-in-Training*  
*Association psychanalytique de France*

Germano Vollmer Filho  
*Training and Supervising Analyst*  
*Past-President*  
*Porto Alegre Psychoanalytic Society*

Steven Wainrib  
*Psychiatrist*  
*Titular Member*  
*Société psychanalytique de Paris*  
*Curricular Director*  
*Université de Paris-VII*

Robert S. Wallerstein  
*Training and Supervising Analyst*  
*San Francisco Psychoanalytic Institute*  
*Professor Emeritus and Former Chair,*  
*Department of Psychiatry*  
*University of California, San Francisco*  
*School of Medicine*

Richard M. Waugaman, M.D.  
*Training and Supervising Analyst*

*Washington Psychoanalytic Institute*

Inge Weber, Psy.D.  
*Doctor of Natural Sciences*  
*Psychoanalyst (German Psychoanalytic*  
*Society)*

Kaspar Weber, M.D.  
*FMG specialist in Psychiatry and*  
*Psychotherapy*  
*Psychoanalyst*  
*Member*  
*Société Suisse de Psychanalyse*

Daniel Widlöcher, M.D., Psy.D.  
*Professor Emeritus*  
*Université Pierre-et-Marie-Curie, Paris-VI*

Reiner Wild  
*Doctor of Philosophy*  
*Professor of New German Literary*  
*History*  
*University of Mannheim*

Pérel Wilgowicz  
*Titular Member*  
*Société psychanalytique de Paris*

Herbert Will, M.D.  
*Theologian*  
*Psychoanalyst*

Gerhard Wittenberger, Ph.D., DGSV  
*Group-dynamics Trainer*  
*Psychoanalyst*

Clifford Yorke  
*Physician*  
*Training Analyst*  
*British Psychoanalytical Society*

Roberto Yutaka Sagawa  
*Assistant Professor and Clinical*  
*Supervisor*  
*Psychology Department*  
*Universidade Estadual Paulista (Sao*  
*Paulo)*

Beverley D. Zabriskie, MSW  
*Jungian Analyst*

Sharon Zalusky, Ph.D.  
*North American Regional Editor*  
*International Psychoanalysis*  
*International Psychoanalytical Associa-*  
*tion Newsletter Chair*  
*The American Psychoanalytic*  
*Association*

Mathieu Zannotti  
*Pediatric Psychiatrist*

Franck Zigante  
*Psychiatrist*  
*Assistant Chief Clinician, Faculty of*  
*Medicine*  
*Université de Paris-VI*

# THEMATIC OUTLINE

## THEMATIC OUTLINE

*This outline provides a general overview of the conceptual structure of the International Dictionary of Psychoanalysis. The outline is organized by four major categories: Concepts/Notions, Biographies, Works, and History. All categories are subcategorized, with the exception of Biographies. The entries are listed alphabetically within each category or subcategory. For ease of reference, one entry may be listed under several categories.*

### **I. Concepts/Notions**

Abandonment  
Absence  
Abstinence/rule of abstinence  
Act, action  
Acting out/acting in  
Action-language  
Action-(re)presentation  
Action-thought (H. Kohut)  
Active technique  
Activity/passivity  
Actual neurosis/defense neurosis  
Acute psychoses  
Adaptation  
Addiction  
Adhesive identification  
Adolescence  
Adolescent crisis  
Adoption  
Affects, quota of affect  
Agency  
Alpha-elements  
Aggressiveness/aggression  
Alchemy  
Alcoholism  
Alienation  
Allergic object relationship  
Allergy  
Alpha function  
Alter ego  
Altruism  
Amae, concept of

Ambivalence  
Amentia  
Amnesia  
Amphimixia/amphimixis  
Anaclisis/anaclitic  
Anality  
Anagogical interpretation  
Analyzability  
Analysand  
Analyse quatrième  
  
**Analytical Psychology (Jung)**  
Active imagination  
Amplification  
Analytical psychology  
Archetype  
Collective unconscious  
Compensation  
Complex  
Ego  
Extroversion/introversion  
Individuation  
Interpretation of dreams  
Numinous  
Psychological types  
Projection and “participation mystique”  
Self  
Shadow  
Synchronicity  
Transference/counter-transference  
  
Animal magnetism  
Animistic thought

Animus-Anima  
Anorexia nervosa  
Anticathexis/counter-cathexis  
Anticipatory ideas  
Antinarcissism  
  
**Anxiety**  
Annihilation anxiety  
Anxiety  
Anxiety dream  
Anxiety, development of  
Signal anxiety  
  
Aphanisis  
Aphasia  
Applied psychoanalysis and the interaction  
of psychoanalysis  
Archaic  
Archaic mother  
Archeology, the metaphor of  
Arrogance  
As if personality  
Asthma  
Attachment  
Attention  
Autistic capsule/nucleus  
Autistic defenses  
Autobiography  
Autoeroticism  
Automatism  
Autoplastic  
Autosuggestion  
Basic assumption



Basic fault  
 Belief  
 Benign/malignant regression  
 Beta-elements  
 Beta-screen  
 Binding/unbinding of the instincts  
 Biological bedrock  
 Birth  
 Bisexuality  
 Bizarre object  
 Black hole  
 Blank/non-delusional psychoses  
 Body image  
 Borderline conditions  
 Boredom  
 Boundary violations  
 Breakdown  
 Breastfeeding  
 Breast, good/bad object  
 Bulimia  
 Capacity to be alone  
 Catastrophic change  
 Cathartic method  
 Cathectic energy  
 Cathexis  
 Censoring the lover in her  
 Censorship  
 Certainty  
 Change

**Character**

Character formation  
 Character neurosis  
 Child analysis  
 Childhood  
 Children's play  
 Civilization (*Kultur*)  
 Claustrophobia  
 Clinging instinct  
 Collective psychology  
 Combined parent figure  
 Compensatory structures  
 Complementary series

**Complex**

Castration complex  
 Complex  
 Dead mother complex  
 Father complex  
 Nuclear complex  
 Oedipus complex  
 Oedipus Complex, early  
 Compromise formation  
 Compulsion

Concept  
 Condensation  
 Conflict  
 Conscious processes  
 Consciousness  
 Constitution  
 Construction-reconstruction  
 Contact and psychoanalysis  
 Contact-barrier  
 Container-Contained  
 Contradiction  
 Conversion  
 Coprophilia  
 Counter-identification  
 Counter-Oedipus  
 Counterphobic  
 Counter-transference  
 Creativity  
 Cruelty  
 Cryptomnesia  
 Cultural transmission  
 Cure  
 Danger  
 Dark continent  
 Daydream  
 Day's residues  
 Death instinct (Thanatos)  
 Decathexis

**Defense**

Defense  
 Defense mechanisms  
 Manic defenses  
 Neuro-psychosis of defense  
 Neurotic defenses  
 Deferred action  
 Deferred action and trauma  
 Déjà-vu  
 Delusion  
 Demand  
 Dementia  
 Depersonalization

**Depression**

Basic depression  
 Depressive position  
 Postnatal/postpartum depression  
 Transference depression  
 Deprivation  
 Desexualization  
 Destrudo  
 Determinism  
 Developmental disorders  
 Dipsomania

Direct analysis  
 Directed daydream (R. Desoille)  
 Disavowal  
 Discharge  
 Discourse  
 Disintegration, feelings of, anxieties  
 Disintegration products  
 Dismantling  
 Disorganisation  
 Displacement  
 Doing/Undoing  
 Double bind  
 Double, The  
 Doubt

**Dream**

Birth, dream of  
 Convenience, dream of  
 Dream  
 Dream-like memory  
 Dream screen  
 Dream symbolism  
 Dream work  
 Dream's navel  
 Examination dreams  
 Hypocritical dream  
 Irma's injection, dream of  
 Latent dream thoughts  
 Mourning, dream of  
 Nakedness, dream of  
 Punishment, dream of  
 Premonitory dreams  
 Repetitive dreams  
 Typical dreams

**Drive**

Drive/instinct  
 Partial drive  
 Sexual drive  
 Subject of the drive  
 Dualism  
 Dynamic point of view  
 Early interactions  
 Economic point of view  
 Elasticity

**Ego**

Antilibidinal ego/internal saboteur  
 Ego  
 Ego, alteration of the  
 Ego autonomy  
 Ego boundaries  
 Ego, damage inflicted on  
 Ego (ego psychology)  
 Ego feeling

- Ego functions  
 Ego ideal  
 Ego ideal/ideal ego  
 Ego identity  
 Ego-instinct  
 Ego interests  
 Ego-libido/object-libido  
 Ego psychology  
 Ego, splitting of the  
 Ego states  
 Ego-syntonic  
 Pleasure ego/reality ego  
 Tube-ego
- Emotion  
 Empathy  
 Encopresis  
 Encounter  
 Enuresis  
 Envy  
 Eros
- Eroticism**  
 Eroticism, anal  
 Eroticism, oral  
 Eroticism, urethral
- Erotogenic masochism  
 Erotogenic zone  
 Erotogenicity  
 Erotomania  
 Erythrophobia (fear of blushing)  
 Estrangement  
 Ethics  
 Event  
 Excitation  
 Exhibitionism  
 Experience of satisfaction  
 Externalization-internalization  
 Face-to-face situation  
 Facilitation  
 Family  
 Family romance
- Fantasy**  
 Fantasy  
 Fantasy, formula of  
 Fantasy (reverie)  
 Pregnancy, fantasy of  
 Primal fantasy  
 Rescue fantasies  
 Unconscious fantasy  
 “Vagina dentata,” fantasy of
- Fascination  
 Fatherhood
- Fear  
 Feces  
 Female sexuality  
 Feminine masochism  
 Femininity  
 Feminity, rejection of  
 Fetishism  
 Fixation  
 Flight into illness  
 Foreclosure  
 Forgetting  
 Formations of the unconscious  
 Fort-Da  
 Fragmentation  
 Framework of the psychoanalytic treatment  
 Free association  
 Free energy/bound energy  
 Free-floating attention  
 Friendship  
 Fright  
 Frustration  
 Functional phenomenon  
 Fundamental rule  
 Fusion/defusion  
 Fusion/defusion of Instincts  
 Gain (primary and secondary)  
 Gender identity  
 General theory of seduction  
 Genital love  
 Gift  
 Gifts  
 Good-enough mother  
 Graph of Desire  
 Grid  
 Group analysis  
 Group phenomenon  
 Group psychotherapies  
 Guilt, feeling of  
 Guilt, unconscious sense of  
 Hallucinosi  
 Hallucinatory, the  
 Handling  
 Hatred  
 Helplessness  
 Heredity of acquired characters  
 Hermeneutics  
 Heterosexuality  
 Historical reality  
 Holding  
 Homosexuality  
 Hospitalism  
 Humor  
 Hypercathexis
- Hypnoid states  
 Hypnosis  
 Hyponchondria  
 Hysteria  
 Hysterical paralysis  
 I  
 Id  
 Idealization  
 Idealized parental imago  
 Ideational representation  
 Ideational representative
- Identification**  
 Heroic identification  
 Identification  
 Identification fantasies  
 Identification with the aggressor  
 Imaginary identification/symbolic identification  
 Projective identification
- Identificatory project  
 Identity  
 Ideology  
 Illusion  
 Imaginary, the (Lacan)  
 Imago  
 Imposter  
 Impulsive acts or impulsivity  
 Incest  
 Incompleteness  
 Indications and contraindications for psychoanalysis for an adult  
 Individual  
*Infans*  
 Infant development  
 Infant observation  
 Infant observation (direct)  
 Infant observation (therapeutic)  
 Infantile amnesia  
 Infantile psychosis  
 Infantile schizophrenia  
 Infantile sexual curiosity  
 Infantile, the  
 Inferiority, feeling of  
 Inferiority, feeling of (individual psychology)  
 Inhibition  
 Initial interview(s)  
 Innervation  
 Insight  
 Instinct  
 Instinct for knowledge or research  
 Instinctual impulse  
 Instinctual representative

- Integration  
 Intellectualization  
 Intergenerational  
 Internal object  
 Internal/external reality  
 interpretation  
 Interpretation of dreams  
 Intersubjective/intrasubjective  
 Introjection  
 Introspection  
 Invariant  
 Isakower phenomenon  
 Isolation  
 Jokes  
 Jouissance (Lacan)  
 Judgment of condemnation  
 Knot  
 L and R schemas  
 Lack of differentiation  
 Language and disturbances of language  
 Latency period  
 Latent  
 Law of the father  
 Lay analysis  
 Letter, the  
 Libidinal development  
 Libido  
 Lie  
 Life instinct (Eros)  
 Lifting of amnesia  
 Linking, attacks on  
 Listening  
 Logic(s)  
 Look/gaze  
 Lost object  
 Love  
 Love-Hate-Knowledge ( L/H/K links)  
 Magical thinking  
 Mania  
 Manic defenses  
 Manifest  
 Masculine protest (individual psychology)  
 Masculinity/femininity  
 Masochism  
 Mastery  
 Mastery, instinct for  
 Masturbation  
 Maternal  
 Maternal reverie, capacity for  
 Matheme  
 Maturation  
 Megalomania  
 Melancholia  
 Melancholy
- Memoirs of the future  
 Memory  
 Mentalization  
 Metaphor  
 Metapsychology  
 Metonymy  
 Midlife crisis  
 Mnemic symbol  
 Mnemic trace/memory trace  
 Model  
 Modesty  
 Money and psychoanalytic treatment  
 Moral masochism  
 Mother goddess  
 Mothering  
 Motricity, psychomotricity  
 Mourning  
 Mutative interpretation  
 Mutual analysis  
 Mysticism  
 Myth of the hero  
 Myth of origins  
 Mythomania  
 Myths  
 Name-of-the-Father
- Narcissism***  
 Narcissism  
 Narcissism of minor differences  
 Narcissism, primary  
 Narcissism, secondary  
 Narcissistic defenses  
 Narcissistic elation  
 Narcissistic injury  
 Narcissistic neurosis  
 Narcissistic rage  
 Narcissistic transference  
 Narcissistic withdrawal  
 Narco-analysis  
 Need for Ccusality  
 Need for punishment  
 Negation  
 Negative capability  
 Negative hallucination  
 Negative therapeutic reaction  
 Negative, work of the  
 Neopsychoanalysis
- Neurosis***  
 Actual neurosis/defense neurosis  
 Choice of neurosis  
 Failure neurosis  
 Fate neurosis  
 Infantile neurosis
- Neurosis  
 Obsessional neurosis  
 Phobic neurosis  
 Traumatic neurosis  
 War neurosis
- Neurotica  
 Neutrality, benevolent neutrality  
 Nightmare  
 Nirvana Neurasthenia  
 Nocturnal/night terrors  
 Nonverbal communication  
 Normality  
 Nostalgia  
 Object  
 Object *a*  
 Object relations theory  
 Object, change of/choice of  
 Obsession  
 Occultism  
 Oceanic feeling  
 Omnipotence of thoughts  
 Omnipotence, infantile  
 Ontogenesis  
 Operative thinking  
 Optical schema  
 Orality  
 Organ pleasure  
 Organic psychoses  
 Organic repression  
 Organization  
 Orgasm  
 Orgone  
 Other, the  
 Otherness  
 Overdetermination  
 Over-interpretation  
 Pain  
 Pair of opposites  
 Parade of the signifier  
 Paradox  
 Paranoia  
 Paranoid position  
 Paranoid psychosis  
 Paranoid-schizoid position  
 Paraphrenia  
 Parapraxis  
 Parenthood  
 Parricide  
 Pass, the  
 Passion  
 Penis envy  
 Perceptual identity  
 Persecution  
 Perversion

- Phallic mother  
 Phallic woman  
 Phallus  
 Phantom  
 Phobia of committing impulsive acts  
 Phobias in children  
 Phylogenesis  
 Physical pain/psychic pain  
 Pleasure in thinking  
 Pleasure/unpleasure principle  
 Preenatal  
 Prehistory  
 Premature-prematurity  
 Prepsychosis  
 Prereflective unconscious  
 Primal repression  
 Primal scene  
 Primal, the  
 Primary identification  
 Primary love  
 Primary masochism  
 Primary need  
 Primary object  
 Primary process/secondary process  
 Primitive  
 Primitive agony  
 Primitive horde  
 Principle of (neuronal) inertia  
 Principle of constancy  
 Principle of identity preservation  
 Principles of mental functioning  
 Perception-consciousness (Pcpt.-Cs.)  
 Pictogram  
 Preconception  
 Preconscious, the  
 Privation  
 Process  
 Processes of development  
 Progressive neutralization  
 Prohibition  
 Projection  
 Protective shield  
 Protective shield, breaking through the  
 Proton-pseudos  
 Protothoughts  
 Psychodrama  
 Psi system  
 Psyche/psychism  
 Psychic apparatus  
 Psychic causality  
 Psychic energy  
 Psychic envelope  
 Psychic reality  
 Psychic structure
- Psychic temporality  
 Psychical representative  
 Psychoanalyst  
 Psychoanalytic epistemology  
 Psychoanalytic family therapy  
 Psychoanalytic filiations  
 Psychoanalytic treatment  
 Psychoanalytical nosography  
 Psychobiography  
 Psychogenesis/organogenesis  
 Psychogenic blindness  
 Psychohistory  
 Psychological tests  
 Psychoses  
 Psychoses, chronic and delusional  
 Psychosexual development  
 Psychosomatic  
 Psychotherapy  
 Psychotic defenses  
 Psychotic/neurotic  
 Psychotic panic  
 Psychotic part of the personality  
 Psychotic potential  
 Purposive idea  
 Puberty  
 Puerperal psychoses  
 Purified-pleasure-ego  
 Quantitative/qualitative  
 Rationalization  
 Reaction-formation  
 Real, the (Lacan)  
 Real, Symbolic, and Imaginary father  
 Real trauma  
 Reality principle  
 Reality testing  
 Realization  
 Reciprocal paths of influence (libidinal coexcitation)  
 Regression  
 Relations (commensalism, parasitism, symbiosis)  
 Relaxation principle and neo-catharsis  
 Relaxation psychotherapy  
 Remembering  
 Reminiscences  
 Reparation  
 Repetition  
 Repetition compulsion  
 Representability  
 Representation  
 Representation of affect  
 Representative  
 Repressed
- Repressed, derivative of the; derivative of the unconscious  
 Repression  
 Repression, lifting of  
 Repudiation  
 Resistance  
 Return of the repressed  
 Reversal into the opposite  
 Rite and ritual  
 Rivalry  
 Sadism  
 Sadoomasochism  
 Schizophrenia  
 Scopophilia/scopophilia  
 Scotomization  
 Screen Memory  
 Secondary revision  
 Secret  
 Seduction  
 Seduction scenes  
 Selected fact  
 Sense/nonsense  
 Sexual theories of children  
 Sexual trauma  
 Sexuality  
 Sexualization  
 Sexuation, formulas of  
 Shame  
 Signifier  
 Signifier/signified
- Self**  
 Bipolar self  
 False self  
 Grandiose self  
 Heroic self  
 Self  
 Self-analysis  
 Self-consciousness  
 Self-esteem  
 Self-hatred  
 Self-image  
 Self mutilation in children  
 Self-object  
 Self-preservation  
 Self psychology  
 Self-punishment  
 Self-representation  
 Self-state dream  
 Self (true/false)  
 Self, the  
 Turning around on the subject's own self  
 Sexual differentiation  
 Signifying chain

- Skin-ego  
 Silence  
 Sleep/wakefulness  
 Slips of the tongue  
 Smell, sense of  
 Skin  
 Social feeling (individual psychology)  
 Somatic compliance  
 Somnambulism  
 Specific action  
 Split object  
 Splitting  
 Splitting of the subject  
 Splitting of the object  
 Splitting, vertical and horizontal  
 Squiggle
- Stages**  
 Anal-sadistic stage  
 Genital stage  
 Libidinal stage  
 Mirror stage  
 Oral-sadistic stage  
 Oral stage  
 Phallic stage  
 Quasi-independence/transitional Stage  
 Stage (or phase)  
 Stammering  
 State of being in love  
 Stranger  
 Strata/stratification  
 Structural theories  
 Subconscious  
 Subject  
 Subject of the unconscious  
 Subject's castration  
 Subject's desire  
 Sublimation  
 Substitute/substitutive formation  
 Substitutive formation  
 Sucking/thumbsucking  
 Sudden involuntary idea  
 Suffering  
 Suggestion  
 Suicidal behavior  
 Suicide  
 Sum of excitation  
 Superego  
 Supervised analysis (control case)  
 Suppression  
 Symbiosis/symbiotic relation  
 Symbol  
 Symbolic Equation  
 Symbolic realization
- Symbolic, the (Lacan)  
 Symbolism  
 Symbolism, process of  
 Symptom  
 Symptom/sinthome  
 Symptom-formation  
 System/systemic  
 Tenderness  
 Time  
 Taboo  
 Taboo of virginity  
 Tact  
 Technique with adults, psychoanalytic  
 Technique with children, psychoanalytic  
 Telepathy  
 Termination of treatment  
 Therapeutic alliance  
 Thing, the  
 Thing-presentation  
 Thought  
 Thought-thinking apparatus  
 Thought identity  
 Tics  
 Topographical point of view  
 Topology  
 Totem/totemism  
 Training analysis  
 Training of psychoanalysts  
 Trance  
 Transcultural
- Transference**  
 Idealizing transference  
 Lateral transference  
 Mirror transference  
 Negative transference  
 Psychotic transference  
 Resolution of the transference  
 Transference depression  
 Transference  
 Transference/counter-transference (analytical psychology)  
 Transference hatred  
 Transference in children  
 Transference love  
 Transference neurosis  
 Transference of creativity  
 Transference relationship  
 Twinship transference/alter ego  
 transference  
 Transformations  
 Transgression  
 Transitional object  
 Transitional object, space
- Transitional phenomena  
 Translation  
 Transmuting internalization  
 Transsexualism  
 Trauma  
 Truth  
 Turning around  
 Ulcerative colitis  
 Unary trait  
 Unconscious, the  
 Unconscious concepts  
 Unpleasure  
 Unvalidated unconscious  
 Vertex  
 Violence, instinct of  
 Visual  
 Voyeurism  
 Want of being/lack of being  
 Weaning  
*Weltanschauung*  
 Wish  
 Wish for a baby  
 Wish-fulfillment  
 Wish, hallucinatory satisfaction of a  
 Wish/yearning  
 Witch of Metapsychology, the  
 Word association  
 Work (as a psychoanalytical notion)  
 Word-presentation  
 Working over  
 Working-off mechanisms  
 Working-through

## II. Biographies

- Abel, Carl  
 Aberastury, Arminda, also known as "La Negra"  
 Abraham, Karl  
 Abraham, Nicolas  
 Adler, Alfred  
 Aichhorn, August  
 Alexander, Franz Gabriel  
 Allendy, René Félix Eugène  
 Allendy-Nel-Dumouchel, Yvonne  
 Althusser, Louis  
 Alvarez de Toledo, Luisa Augusta Rebeca  
 Gambier de  
 Andersson, Ola  
 Andreas-Salomé, Louise, dite Lou  
 Anzieu, Didier  
 Arlow, Jacob A.  
 Aubry Weiss, Jenny  
 Aulagnier-Spairani, Piera  
 Bachelard, Gaston

- Baginsky, Adolf  
 Bak, Robert C.  
 Balint, Michael (Bálint [Bergsmann], Mihály)  
 Balint-Szekely-Kovács, Alice  
 Baranger, Willy  
 Baudouin, Charles  
 Beirnaert, Louis  
 Benedek, Therese  
 Berge, André  
 Bergler, Edmund  
 Berman, Anne  
 Bernays, Minna  
 Bernfeld, Siegfried  
 Bernheim, Hippolyte  
 Bettelheim, Bruno  
 Bibring, Edward  
 Bibring-Lehner, Grete  
 Bick, Esther  
 Bigras, Julien Joseph Normand  
 Binswanger, Ludwig  
 Bion, Wilfred Ruprecht  
 Bjerre, Poul  
 Blanton, Smiley  
 Bleger, José  
 Bleuler, Paul Eugen  
 Bloch, Jean- Richard  
 Blos, Peter  
 Boehm, Felix Julius  
 Bonaparte, Marie Léon  
 Borel, Adrien Alphonse Alcide  
 Bornstein, Berta  
 Bose, Girindrasekhar  
 Bouvet, Maurice Charles Marie Germain  
 Bowlby, Edward John Mostyn  
 Brentano, Franz von  
 Breton, André  
 Breuer, Josef  
 Brierley, Marjorie Flowers  
 Brill, Abraham Arden  
 Brücke, Ernst Wilhelm von  
 Brun, Rudolf  
 Brunswick, Ruth Mack  
 Bullitt, William C.  
 Burlingham-Tiffany, Dorothy  
 Burrow, Trigant  
 Cárcamo, Celes Ernesto  
 Caruso, Igor A.  
 Cénac, Michel  
 Certeau, Michel de  
 Charcot, Jean Martin  
 Chentrier, Théodore  
 Chertok, Léon (Tchertok, Lejb)  
 Choisy, Maryse  
 Claparède, Édouard  
 Clark-Williams, Margaret  
 Claude, Henri Charles Jules  
 Corrao, Francesco  
 Dalbiez, Roland  
 Delay, Jean  
 Delboeuf, Joseph Rémi Léopold  
 Delgado, Honorio  
 Desoille, Robert  
 Deuticke, Franz  
 Deutsch, Felix  
 Deutsch-Rosenbach, Helene  
 Devereux, Georges  
 Diatkine, René  
 Dolto-Marette, Françoise  
 Doolittle-Aldington, Hilda (H.D.)  
 Dosuzkov, Theodor  
 Dubal, George  
 Dugautiez, Maurice  
 Eckstein, Emma  
 Eder, David Montagu  
 Eissler, Kurt Robert  
 Eissler-Selke, Ruth  
 Eitington, Max  
 Ellenberger, Henri Frédéric  
 Embirikos, Andreas  
 Emden, Jan Egbert Gustaaf Van  
 Enriquez-Joly, Micheline  
 Erikson, Erik Homburger  
 Ey, Henri  
 Fairbairn, William Ronald Dodds  
 Fanon, Frantz  
 Favez, Georges  
 Favez-Boutonier, Juliette  
 Favreau, Jean Alphonse  
 Fechner, Gustav Theodor  
 Federn, Paul  
 Fenichel, Otto  
 Ferenczi, Sándor  
 Fliess, Wilhelm  
 Flournoy, Henri  
 Flournoy, Théodore  
 Flügel, John Carl  
 Fluss, Gisela  
 Fornari, Franco  
 Foulkes (Fuchs), Siegmund Heinrich  
 Franco da Rocha, Francisco  
 Frankl, Viktor  
 Freud, (Jean) Martin  
 Freud-Nathanson, Amalia Malka  
 Freud, Anna  
 Freud-Bernays, Martha  
 Freud, Ernst  
 Freud, Jakob Kolloman (ou Keleman ou Kallamon)  
 Freud, Josef  
 Freud, Oliver  
 Freud, Sigmund Schlomo  
 Freud, Sigmund, (siblings)  
 Freund Toszeghy, Anton von  
 Friedländer-Fränk, Kate  
 Frink, Horace Westlake  
 Fromm, Erich  
 Fromm-Reichmann, Frieda  
 Gaddini, Eugenio  
 Gardiner, Muriel M.  
 Garma, Angel  
 Gattel, Felix  
 Glover, Edward  
 Glover, James  
 Göring, Matthias Heinrich  
 Graf, Herbert  
 Graf, Max  
 Granoff, Wladimir Alexandre  
 Greenacre, Phyllis  
 Greenson, Ralph  
 Gressot, Michel  
 Groddeck, Georg Walther  
 Gross, Otto Hans Adolf  
 Guex, Germaine  
 Guilbert, Yvette  
 Halberstadt-Freud, Sophie  
 Hartmann, Heinz  
 Heimann, Paula  
 Held, René  
 Heller, Hugo  
 Hellman Noach, Ilse  
 Hermann, Imre  
 Hesnard, Angélo Louis Marie  
 Heuyer, Georges  
 Hilferding-Hönigsberg, Margarethe  
 Hirschfeld, Elfriede  
 Hirschmann, Eduard  
 Hoffer, William (Wilhelm)  
 Hollitscher-Freud, Mathilde  
 Hollós, István  
 Horney-Danielson, Karen  
 Hug-Hellmuth-Hug von Hugenstein, Hermine  
 Isaacs-Sutherland, Susan  
 Isakower, Otto  
 Jacobson, Edith  
 Janet, Pierre  
 Jankélévitch, Samuel  
 Jekels (Jekeles), Ludwig  
 Jelliffe, Smith Ely  
 Jones, Ernest

- Jouve, Pierre Jean  
 Jung, Carl Gustav  
 Jung-Rauschenbach, Emma  
 Jury, Paul  
 Kardiner, Abram  
 Katan, Maurits  
 Katan-Rosenberg, Anny  
 Kemper, Werner Walther  
 Kestemberg-Hassin, Evelyne  
 Kestemberg, Jean  
 Khan, Mohammed Masud Rasa  
 Klein-Reizes, Melanie  
 Koch, Adelheid Lucy  
 Kohut, Heinz  
 Kosawa, Heisaku  
 Kouretas, Démétrios  
 Kovács-Prosznitz, Vilma  
 Kraus, Karl  
 Kris, Ernst  
 Kris-Rie, Marianne  
 Lacan, Jacques-Marie Émile  
 Laforgue, René  
 Lagache, Daniel  
 Lainé, Tony  
 Laing, Ronald David  
 Lampl, Hans  
 Lampl-de Groot, Jeanne  
 Landauer, Karl  
 Langer, Marie Glass Hauser de  
 Lanzer, Ernst  
 Laurent-Lucas-Championnière-Maugé,  
 Odette  
 Le Bon, Gustave  
 Lebovici, Serge Sindel Charles  
 Lechat, Fernand  
 Leclair (Liebschutz), Serge  
 Leeuw, Pieter Jacob Van der  
 Lehrman, Philip R.  
 Leuba, John  
 Levi Bianchini, Marco  
 Liberman, David  
 Liebeault, Ambroise Auguste  
 Limentani, Adam  
 Lorand, Sándor  
 Low, Barbara  
 Lowenstein, Rudolph M.  
 Maeder, Alphonse E.  
 Mahler-Schönberger, Margaret  
 Main, Thomas Forrest  
 Mâle, Pierre  
 Malinowski, Bronislaw Kaspar  
 Mann, Thomas  
 Mannoni, Dominique-Octave  
 Mannoni-Van der Spoel, Maud  
 (Magdalena)  
 Marciniowski, Johannes (Jaroslaw)  
 Marcondes, Durval Bellegarde  
 Marcuse, Herbert  
 Martins, Cyro  
 Marty, Pierre  
 Matte-Blanco, Ignacio  
 Mauco, Georges  
 Mead, Margaret  
 Meng, Heinrich  
 Menninger, Karl A.  
 Merleau-Ponty, Maurice  
 Meyer, Adolf F.  
 Meyerson, Ignace  
 Meynert, Theodor  
 Milner-Blackett, Marion  
 Minkowska-Brokman, Françoise  
 Minkowski, Eugène  
 Mitscherlich, Alexander  
 Mom, Jorge Mario  
 Money-Kyrle, Roger Earle  
 Moreno, Jacob Levy  
 Morgenstern-Kabatschnik, Sophie  
 Morgenthaler, Fritz  
 Morichau-Beauchant, Pierre Ernest René  
 Morselli, Enrico  
 Moser-van Sulzer-Wart, Fanny Louise  
 Müller-Braunschweig, Carl  
 Murray, Henry A.  
 Musatti, Cesare  
 Nacht, Sacha Emanoil  
 Nin, Anaïs  
 Nodet, Charles-Henri  
 Nunberg, Hermann  
 Oberholzer, Emil  
 Odier, Charles  
 Ophuijsen, Johan H. W. Van  
 Ossipov, Nikolai Iegrafovitch  
 Pankejeff, Sergueï  
 Pankow, Gisela  
 Pappenheim, Bertha  
 Parcheminey, Georges  
 Pasche, Francis Léopold Philippe  
 Payne, Sylvia May  
 Peraldi, François  
 Perestrello, Danilo  
 Perrier, François  
 Perrotti, Nicola  
 Pfister, Oskar Robert  
 Piaget, Jean  
 Pichon, Édouard Jean Baptiste  
 Pichon-Rivière, Enrique  
 Politzer, Georges  
 Porto-Carrero, Julio Pires  
 Pötzl, Otto  
 Putnam, James Jackson  
 Racamier, Paul-Claude  
 Racker, Heinrich  
 Radó, Sándor  
 Raimbault, Émile  
 Rambert, Madeleine  
 Rank (Rosenfeld) Otto  
 Rank-Minzer (ou Münzer), Beata  
 Rapaport, David  
 Rascovsky, Arnaldo  
 Rees, John Rawlings  
 Régis, Emmanuel Jean-Baptiste Joseph  
 Reich, Annie  
 Reich, Wilhelm  
 Reik, Theodor  
 Reverchon-Jouve, Blanche  
 Rickman, John  
 Rie, Oksar  
 Rittmeister, John Friedrich Karl  
 Riviere-Hodgson Verrall, Joan  
 Robertson, James  
 Róheim, Géza  
 Rolland, Romain Edme Paul-Émile  
 Rorschach, Hermann  
 Rosenfeld, Eva Marie  
 Rosenfeld, Herbert Alexander  
 Rosenthal, Tatiana  
 Ross, Helen  
 Rubinstein, Benjamin B.  
 Rycroft, Charles Frederick  
 Sachs, Hanns  
 Sadger, Isidor Isaak  
 Sandler, Joseph  
 Sarasin, Philipp  
 Saussure, Raymond de  
 Schiff, Paul  
 Schilder, Paul Ferdinand  
 Schlumberger, Marc  
 Schmideberg-Klein, Melitta  
 Schmidt, Vera Federovna  
 Schneider, Ernst  
 Schreber, Daniel Paul  
 Schultz-Hencke, Harald Julius Alfred Carl-  
 Ludwig  
 Schur, Max  
 Sechehaye-Burdet, Marguerite  
 Servadio, Emilio  
 Sharpe, Ella Freeman  
 Silberer, Herbert  
 Silberstein, Eduard  
 Simmel, Ernst  
 Smirnoff, Victor Nikolaïevitch

Sokolnicka-Kutner, Eugénie  
 Spielrein, Sabina  
 Spitz, René Arpad  
 Stekel, Wilhelm  
 Sterba, Richard F.  
 Sterba-Radanowicz-Hartmann, Editha  
 Stoller, Robert J.  
 Stone, Leo  
 Storfer, Adolf Josef  
 Strachey, James Beaumont  
 Strachey-Sargent, Alix  
 Sullivan, Harry Stack  
 Swoboda, Hermann  
 Szondi, Leopold  
 Tausk, Viktor  
 Thompson, Clara M.  
 Tomasi di Palma di Lampedusa-Wolff  
 Somersee, Alessandra  
 Torok, Maria  
 Tosquelles, François  
 Tustin, Frances  
 Urbantschitsch (Urban), Rudolf von  
 Valdizán Hermilio  
 Viderman, Serge  
 Waelder, Robert  
 Wagner-Jauregg, Julius (Julius Wagner Ritter von Jauregg)  
 Walter, Bruno  
 Weininger, Otto  
 Weiss, Edoardo  
 Wilbur, George B.  
 Winnicott, Donald Woods  
 Winterstein, Alfred Freiherr von  
 Wittels, Fritz (Siegfried)  
 Wittkower, Eric  
 Wolfenstein, Martha  
 Wolff, Antonia Anna  
 Wulff, Mosche (Woolf, Moshe)  
 Zavitzianos, Georges  
 Zetzel-Rosenberg, Elizabeth  
 Zulliger, Hans  
 Zweig, Arnold  
 Zweig, Stefan

### III. Works

#### A) Freud

“Analysis of a Phobia in a Five-year-old Boy” (little Hans)  
 “Analysis Terminable and Interminable”  
 “Autobiographical Study, An”  
*Beyond the Pleasure Principle*  
*Civilization and its Discontents*  
 “Claims of Psychoanalysis to Scientific Interest”

“Constructions in Analysis”  
 “Contributions to the Psychology of Love”  
 “Creative Writers and Day-Dreaming”  
*Delusions and Dreams in Jensen's “Gradiva”*  
 “Disturbance of Memory on the Acropolis, A”  
 “Dostoyevsky and Parricide”  
*Ego and the Id, The*  
*Five Lectures on Psycho-Analysis*  
 “From the History of an Infantile Neurosis” (Wolf Man)  
*Future of an Illusion, The*  
*Gesammelte Schriften*  
*Gessammelte Werke*  
*Group Psychology and the Analysis of the Ego*  
 “Heredity and the Aetiology of the Neuroses”  
*Inhibitions, Symptoms and Anxiety*  
 “Instinct and their Vicissitudes”  
*Interpretation of Dreams, The*  
*Introductory Lectures on Psychoanalysis*  
*Jokes and their Relation to the Unconscious*  
*Klinische Studie über die halbseitiger Cerebrallähmung der Kinder* [Clinical study of infantile cerebral diplegia]  
*Leonardo da Vinci and a Memory of his Childhood*  
 “Lines of Advance in Psycho-Analytic Therapy”  
 “Metapsychologic Complement to the Theory of Dreams”  
*Moses and Monotheism”*  
 “Moses of Michelangelo, The”  
 “Mourning and Melancholia”  
 “Negation”  
*Nervous Anxiety States and their Treatment*  
 “Neurasthenia and ‘Anxiety Neurosis””  
*New Introductory Lectures on Psychoanalysis*  
 “Note upon the ‘Mystic Writing Pad,’ A”  
 “Notes upon a Case of Obsessional Neurosis” (Rat Man)  
 “On Dreams”  
 “On Narcissism: An Introduction”  
 “On the History of the Psychoanalytic Movement”  
 “On the Sexual Theories of Children”  
 “On Transience”  
*Opere ( writing of Sigmund Freud)*  
 “Outline of Psychoanalysis, An”  
*Phylogenetic Fantasy, A :Overview of the Transference Neuroses*  
 “Project for a Scientific Psychology, A”

“Psycho-Analytic Notes on an Autobiographical Account of a Case of Paranoia (Dementia Paranoides)”  
 “Psychogenesis of a Case of Homosexuality in a Woman, The”  
*Psychopathology of Everyday Life, The*  
*Question of Lay Analysis, The*  
 “Recommendations to Physicians Practicing Psychoanalysis”  
 “Remembering, Repeating and Working-Through”  
 “Repression”  
 “Seventeenth-century Demonological Neurosis, A”  
 “Some Psychical Consequences of the Anatomical Distinction between the Sexes”  
 “Splitting of the Ego in the Process of Defense, The”  
*Standard Edition of the Complete Psychological Works of Sigmund Freud*  
*Studies on Hysteria*  
 “Sexual Enlightenment Of Children, The”  
 “‘Uncanny,’ The”  
 “Unconscious, The”  
 “Theme of the Three Caskets, The”  
*Thomas Woodrow Wilson, Twenty-eighth President of the United States. A Psychological Study*  
 “Thoughts for the Times on War and Death”  
*Three Essays on the Theory of Sexuality*  
*Totem and Taboo*  
 “Why War?”  
 “‘Wild’ Psycho-Analysis”

#### B) Other Works

*Anti-Oedipus: Capitalism and Schizophrenia* (Gilles Deleuze et Felix Guattari)  
*Apprenti-historien et le maître-sorcier (L-)* [The apprentice historian and the master sorcerer] ( *Piera Aulagnier*)  
*Basic Neurosis, The—Oral Regression and Psychic Masochism* (Edmund Bergler)  
*Basic Problems of Ethnopsychiatry* (Georges Devereux)  
*Book of the It, The* (Georg Groddeck)  
*Character Analysis* (Wilhelm Reich)  
*Childhood and Society* (Erik H. Erikson)  
*Christians and Jews: A Psychoanalytical Study* (Rudolf M. Loewenstein)  
*Collected papers on schizophrenia and related subjects* (Harold F. Searles)  
 “Confusion of Tongues between Adults and the Child” (Sándor Ferenczi)



- Construction de l'espace analytique (La-)*  
[Constructing the analytical space]  
(Serge Viderman)
- Development of Psycho-Analysis, The* (Sándor Ferenczi and Otto Rank)
- Don Juan and the Double* (Otto Rank)
- Dreams and Myths* (Abraham Karl)
- "Dream of the Wise Baby, The" (Sandor Ferenczi)
- Écrits* (Jacques Lacan)
- Ego and the Mechanisms of Defence, The*  
(Anna Freud)
- Ego Psychology and the Problem of Adaptation* (Heinz Hartmann)
- Ego Psychology and Psychosis* (Paul Federn)
- Elementi di psicoanalisi* (Eduardo Weiss)
- Empty Fortress, The* (Bruno Bettelheim)
- Envy and Gratitude* (Melanie Klein)
- Estudios sobre técnica psicoanalítica* (Heinrich Racker)
- Freud: Living and Dying* (Max Schur)
- Freud's Self-Analysis* (Didier Anzieu)
- Freud, the Secret Passion* (John Huston)
- Hamlet and Oedipus* (Ernest Jones)
- "Introjection and Transference" (Sandor Ferenczi)
- Jalousie amoureuse, La* (Amorous jealousy)(Daniel Lagache)
- Language of Psychoanalysis, The* (Jean Laplanche and Jean-Bertrand Pontalis)
- Learning from Experience* (Wilfred R. Bion)
- Lingüística, Interacción comunicativa y Proceso psicoanalítico* (David Liberman)
- Life and Work of Sigmund Freud* (Ernest Jones)
- Life and Works of Edgar Allen Poe, The: A Psychoanalytic Interpretation* (Marie Bonaparte)
- Mass Psychology of Fascism, The* (Wilhelm Reich)
- Minutes of the Vienna Psychoanalytic Society* (Hermann Numberg and Ernst Federn)
- Nervous Anxiety States and their Treatment*  
(Wilhelm Stekel)
- Neurosis and Human Growth* (Karen Horney)
- "On the Origin of the 'Influencing Machine' in Schizophrenia" (Viktor Tausk)
- Philippson Bible
- Psychanalyse et Pédiatrie* [Psychoanalysis and pediatrics] (Francoise Dolto)
- Psychoanalyse des névroses et des psychoses, La* (Regis Emmanuel and Angelo Hesnard)
- Psycho-Analysis of Children, The* (Melanie Klein)
- Psychoanalysis of Dreams* (Angel Garma)
- Psychoanalysis of Fire, The* (Gaston Bachelard)
- Psychoanalysis and the Neuroses* (René Laforgue and René Allendy)
- Psychoanalytic Theory of Neuroses, The*  
(Otto Fenichel)
- Psychoanalytical Treatment of Children*  
(Anna Freud)
- Psychology of Women, The. A Psychoanalytic Interpretation* (Helene Deutsch)
- Psychology of Dementia præcox* (Carl Gustav Jung)
- Psychology of the Unconscious, The* (Carl Gustav Jung)
- Psychopathologie de l'échec (Psychopathology of Failure)* (René Laforgue)
- Qu'est-ce que la suggestion?* [What is suggestion?] (Charles Baudouin)
- Secrets of a Soul* (Georg Wilhelm Pabst)
- Seminar, Lacan's (Jacques Lacan)
- Sex and Character* (Otto Weininger)
- Thalassa. A Theory of Genitality* (Sandor Ferenczi)
- Transference and Countertransference*  
(Heinrich Racker)
- Trattato di psicoanalisi* (Cesare Musatti)
- Trauma of Birth, The* (Otto Rank)
- Unconscious as Infinite Sets, The: An Essay in Bi-Logic* (Ignacio matte-Blanco)
- Violence of Interpretation, The: From Pictogram to Statement* (Piera Castoriadis-Aulagnier)
- Young Girl's Diary, A* (Hermine von Hugel-Hellmuth)
- C) Journals and other publications**
- Almanach der Psychoanalyse*
- American Imago*
- Année psychologique, L'*
- Archives de psychologie, Les*
- Bloc—Notes de la psychanalyse*
- Coq-Héron*
- Disque vert, Le*
- Documents et Débats*
- Études Freudiennes*
- Évolution psychiatrique, L'* (Developments in Psychiatry)
- Fackel, Die*
- Imago. Zeitschrift für die Anwendung der Psychoanalyse auf die Geisteswissenschaften*
- Inconscient, L'*
- International Journal of Psychoanalysis, The*
- Internationale Zeitschrift für (ärztliche) Psychoanalyse*
- Internationaler Psychoanalytischer Verlag*
- Interprétation*
- Jahrbuch der Psychoanalyse*
- Journal de la psychanalyse d'enfants*
- Journal of the American Psychoanalytic Association*
- Nouvelle Revue de psychanalyse*
- Ornicar?*
- Psychanalyse, La*
- Psyché, revue internationale de psychanalyse et des sciences de l'homme* (Psyche, an international review of psychoanalysis and human sciences)
- Psyche. Zeitschrift für Psychanalyse und ihre Anwendungen*
- Psychoanalytic Bewegung, Die*
- Psychoanalytic Quarterly, The*
- Psychoanalytic Review, The*
- Psychoanalytic Study of the Child, The*
- Psychoterapia (Psixoterapija-Obozrenie voprosov lecenija I prikladnoj psixologii)*
- Revista de psicoanálisis*
- Revista de psiquiatria y disciplinas conexas*
- Revue française de psychanalyse*
- Rivista di psicoanalisi*
- Topique*
- Zeitschrift für psychoanalytische Pädagogik*
- Zentralblatt für Psychoanalyse*

**IV. History****A) COUNTRIES****ARGENTINA**

Aberastury, Arminda, also known as "La Negra"

Alvarez de Toledo, Luisa Augusta Rebeca Gambier de

Argentina

Baranger, Willy

Bleger, José

Cárcamo, Celes Ernesto

Langer, Marie Glass Hauser de

Liberman, David

Mom, Jorge Mario

Pichon-Rivière, Enrique

Racker, Heinrich

Rascovsky, Arnaldo

**AUSTRALIA**

Australia

**AUSTRIA**

Adler, Alfred  
 Aichhorn, August  
 Almanach der Psychoanalyse  
 Austria  
 Berggasse 19, Wien IX  
 Bernays, Minna  
 Bernfeld, Siegfried  
 Breuer, Josef  
 Caruso, Igor A.  
 Committee, The  
 Deuticke, Franz  
 Eckstein, Emma  
 Eissler, Kurt Robert  
 Fluss, Gisela  
 Frankl, Viktor  
 Freud, Amalie  
 Freud, Anna  
 Freud, Bernays, Martha  
 Freud, Ernst  
 Freud, Jakob Kolloman  
   (ou Keleman ou Kallamon)  
 Freud, (Jean) Martin  
 Freud, Josef  
 Freud Museum  
 Freud, Oliver  
 Freud, Sigmund Schlomo  
 Freud, Sigmund, ( siblings)  
 Friedländer-Fränk, Kate  
 Graf, Herbert  
 Graf, Max  
 Gross, Otto Hans Adolf  
 Halberstadt-Freud, Sophie  
 Hartmann, Heinz  
 Heller, Hugo (et éditions)  
 Hellman Noach, Ilse  
 Hietzing Schule/Burlingham-Rosenfeld  
 Hilferding-Hönigsberg, Margarethe  
 Hitschmann, Eduard  
 Hollitscher-Freud, Mathilde  
 Hug-Hellmuth-Hug von Hugenstein,  
   Hermine  
 Institut Max-Kassowitz  
 Jekels (Jekeles), Ludwig  
 Kraus, Karl  
 Kris-Rie, Marianne  
 Lanzer, Ernst  
 Lehrinstitut der Wiener  
   psychoanalytischen Vereinigung  
 Meynert, Theodor  
 Pappenheim, Bertha

Pötzl, Otto  
 Rank (Rosenfeld) Otto  
 Rank-Minzer (ou Münzer), Beata  
 Reich, Annie  
 Reich, Wilhelm  
 Reik, Theodor  
 Rie, Oksar  
 Sadger, Isidor Isaak  
 Schilder, Paul Ferdinand  
 Schur, Max  
 Sigmund Freud Museum  
 Silberer, Herbert  
 Stekel, Wilhelm  
 Sterba, Richard F.  
 Swoboda, Hermann  
 Tausk, Viktor  
 Urbantschitsch (Urban), Rudolf von  
 Vienna, Freud's secondary school in  
 Vienna General Hospital  
 Vienna, University of  
 Waelder, Robert  
 Wagner-Jauregg, Julius (Julius Wagner  
   Ritter von Jauregg)  
 Weininger, Otto  
 Wiener psychoanalytische Vereinigung  
 Winterstein, Alfred Freiherr von  
 Wittels, Fritz (Siegfried)  
 Zweig, Stefan

**BELGIUM**

Belgium  
 Delboeuf, Joseph Rémi Léopold  
 Dugautiez, Maurice  
 Lechat, Fernand

**BRAZIL**

Brazil  
 Franco da Rocha, Francisco  
 Kemper, Werner Walther  
 Koch, Adelheid Lucy  
 Marcondes, Durval Bellegarde  
 Martins, Cyro  
 Perestrello, Danilo  
 Porto-Carrero, Julio Pires

**CANADA**

Bigras, Julien Joseph Normand  
 Canada  
 Lainé, Tony  
 Peraldi, François  
 North America  
 Société psychanalytique de Montréal

**CHILE**

Blanco, Ignacio

Chile

**CHINA**

China

**COLOMBIA**

Colombia

**CZECH REPUBLIC**

Czech Republic

**DENMARK**

Denmark

**FINLAND**

Finland

**FRANCE**

Allendy, René Félix Eugène  
 Allendy-Nel-Dumouchel, Yvonne  
 Althusser, Louis  
 Association psychanalytique de France  
 Aulagnier-Spairani, Piera  
 Dolto-Marette, Françoise  
 Enriquez-Joly, Micheline  
 Ey, Henri  
 Favez, Georges  
 Favez-Boutonier, Juliette  
 Favreau, Jean Alphonse  
 Anzieu, Didier  
 Aubry Weiss, Jenny  
 Bachelard, Gaston  
 Beirnaert, Louis  
 Berge, André  
 Berman, Anne  
 Bernheim, Hippolyte  
 Bloch, Jean- Richard  
 Bonaparte, Marie Léon  
 Borel, Adrien Alphonse Alcide  
 Bouvet, Maurice Charles Marie Germain  
 Breton, André  
 Cénac, Michel  
 Centre Alfred-Binet  
 Centre de consultations et de traitements  
   psychanalytiques Jean-Favreau  
 Centre psychopédagogique Claude-  
   Bernard  
 Collège de psychanalystes  
 Colloque sur l' inconscient  
 Certeau, Michel de  
 Charcot, Jean Martin  
 Chentrier, Théodore  
 Chertok, Léon (Tchertok, Lejb)  
 Choisy, Maryse  
 Claude, Henri Charles Jules  
 Dalbiez, Roland

Delay, Jean  
 Desoille, Robert  
 Diatkine, René  
 Flournoy, Henri  
 Flournoy, Théodore  
 France  
 Granoff, Wladimir Alexandre  
 Guilbert, Yvette  
 Held, René  
 Hesnard, Angélo Louis Marie  
 Heuyer, Georges  
 Janet, Pierre  
 Jankélévitch, Samuel  
 Jouve, Pierre Jean  
 Kestemberg-Hassin, Evelyne  
 Kestenber, Jean  
 Jury, Paul  
 Lacan, Jacques-Marie Émile  
 Laforgue, René  
 Lagache, Daniel  
 Lainé, Tony  
 Laurent-Lucas-Championnière-Maugé,  
 Odette  
 Le Bon, Gustave  
 Lebovici, Serge  
 Leclair (Liebschutz), Serge  
 Liebeault, Ambroise Auguste  
 Leuba, John  
 Mâle, Pierre  
 Mannoni, Dominique-Octave  
 Mannoni-Van der Spoel,  
 Maud (Magdalena)  
 Marty, Pierre  
 Mauco, Georges  
 Merleau-Ponty, Maurice  
 Meyerson, Ignace  
 Minkowska-Brokman, Françoise  
 Minkowski, Eugène  
 Morichau-Beauchant, Pierre Ernest René  
 Mouvement lacanien française  
 Nacht, Sacha Emanoel  
 Nodet, Charles-Henri  
 Pankow, Gisela  
 Parcheminey, Georges  
 Pasche, Francis Léopold Philippe  
 Perrier, François  
 Pichon, Édouard Jean Baptiste  
 Politzer, Georges  
 Racamier, Paul-Claude  
 Raimbault, Émile  
 Reverchon-Jouve, Blanche  
 Régis, Emmanuel Jean-Baptiste Joseph  
 Rolland, Romain Edme Paul-Émile  
 Sainte-Anne Hospital

Salpêtrière, hospital  
 Schiff, Paul  
 Schlumberger, Marc  
 Smirnoff, Victor Nikolaïevitch  
 Société française de psychanalyse  
 Société psychanalytique de Paris and Institut  
 de psychanalyse de Paris  
 Torok, Maria  
 Tosquelles, François  
 Viderman, Serge

**GERMANY**

Abel, Carl  
 Abraham, Karl  
 Allgemeine Ärztliche Gesellschaft für  
 Psychotherapie  
 Baginsky, Adolf  
 Berliner Psychoanalytische Poliklinik  
 Berliner Psychoanalytisches Institut  
 Brentano, Franz von  
 Brücke, Ernst Wilhelm von  
 Deutsches Institut für Psychologische For-  
 schung und Psychotherapie (Institut  
 Göring)  
 Eittington, Max  
 Eissler-Selke, Ruth  
 Eittington, Max  
 Fechner, Gustav Theodor  
 Foulkes (Fuchs), Siegmund Heinrich  
 Fromm, Erich  
 Fromm-Reichmann, Frieda  
 Gattel, Felix  
 Germany  
 Goethe (prize)  
 Gross, Otto Hans Adolf  
 Göring, Matthias Heinrich  
 Groddeck, Georg Walther  
 Hirschfeld, Elfriede  
 Horney-Danielson, Karen  
 Jacobson, Edith  
 Kemper, Werner Walther  
 Landauer, Karl  
 Mann, Thomas  
 Marcinowski, Johannes (Jaroslaw)  
 Meng, Heinrich  
 Mitscherlich, Alexander  
 Müller-Braunschweig, Carl  
 Pankow, Gisela  
 Rittmeister, John Friedrich Karl  
 Rosenfeld, Eva Marie  
 Sachs, Hanns  
 Schreber, Daniel Paul  
 Schultz-Hencke, Harald Julius Alfred  
 Carl-Ludwig

Sigmund Freud Institute  
 Tegel (Schloss Tegel)  
 Walter, Bruno  
 Zweig, Arnold

**GREECE**

Embirikos, Andreas  
 Greece  
 Kouretas, Démétrios  
 Zavitzianos, Georges

**HUNGARY**

Abraham, Nicolas  
 Alexander, Franz Gabriel  
 Bak, Robert C.  
 Balint group  
 Balint, Michael (Bálint [Bergsmann],  
 Mihály)  
 Balint-Szekely-Kovács, Alice  
 Benedek, Therese  
 Devereux, Georges  
 Ferenczi, Sándor  
 Freund Toszeghy, Anton von  
 Hermann, Imre  
 Hollós, István  
 Hungarian School  
 Hungary  
 Kovács-Prosznitz, Vilma  
 Lorand, Sándor  
 Radó, Sándor  
 Rapaport, David  
 Róheim, Géza  
 Spitz, René Arpad

**INDIA**

Bose, Girindrasekhar  
 India  
**ISRAEL**  
 Israel  
 Wulff, Mosche (Woolf, Moshe)

**ITALY**

Corrao, Francesco  
 Fornari, Franco  
 Gaddini, Eugenio  
 Italy  
 Levi Bianchini, Marco  
 Morselli, Enrico  
 Musatti, Cesare  
 Perrotti, Nicola  
 Servadio, Emilio  
 Tomasi di Palma di Lampedusa-Wolff  
 Somersee, Alessandra  
 Weiss, Edoardo

**JAPAN**

Japan  
Kosawa, Heisaku

**KOREA**

Korea

**MARTINIQUE**

Martinique

**MEXICO**

Mexico

**NETHERLANDS**

Emden, Jan Egbert Gustaaf Van  
Lampl, Hans  
Lampl-de Groot, Jeanne  
Leeuw, Pieter Jacob Van der  
Netherlands  
Ophuijsen, Johan H. W. Van

**NORTH AFRICA**

North African countries

**NORWAY**

Norway

**Peru**

“A. Z.”  
Delgado, Honorio  
Peru

**PHILIPPINES**

Philippines

**POLAND**

Bornstein, Berta  
Deutsch-Rosenbach, Helene  
Bick, Esther  
Morgenstern-Kabatschnik, Sophie  
Poland

**PORTUGAL**

Portugal

**ROMANIA**

Nacht, Sacha Emanoel  
Romania

**RUSSIA**

Andreas-Salomé, Louise, dite Lou  
Detski Dom  
Dosuzkov, Theodor  
Ossipov, Nikolai Iegrafovitch  
Pankejeff, Sergueï  
Rosenthal, Tatiana  
Russia/USSR

Schmidt, Vera Federovna  
Spielrein, Sabina

**SOUTH AFRICA**

Ellenberger, Henri Frédéric

**SPAIN**

Garma, Angel  
Spain

**SWEDEN**

Andersson, Ola  
Bjerre, Poul  
Sweden

**SWITZERLAND**

Baudouin, Charles  
Binswanger, Ludwig  
Bleuler, Paul Eugen  
Brun, Rudolf  
Burghölzli asylum  
Claparède, Édouard Dubal, George  
Dubal, George  
Gressot, Michel  
Guex, Germaine  
Jung, Carl Gustav  
Jung-Rauschenbach, Emma  
Maeder, Alphonse E.  
Morgenthaler, Fritz  
Moser-van Sulzer-Wart, Fanny Louise  
Oberholzer, Emil  
Odier, Charles  
Pfister, Oskar Robert  
Piaget, Jean  
Rambert, Madeleine  
Rorschach, Hermann  
Sarasin, Philipp  
Saussure, Raymond de  
Schneider, Ernst  
Schweizerische Ärztegesellschaft für  
Psychoanalyse  
Sechehaye-Burdet, Marguerite  
Société psychanalytique de Genève  
Switzerland (French-speaking)  
Switzerland (German-speaking)  
Zulliger, Hans

**UNITED KINGDOM**

Bion, Wilfred Ruprecht  
Bowby, Edward John Mostyn  
Brierley, Marjorie Flowers  
British Psycho-Analytical Society  
Controversial Discussions  
Eder, David Montagu  
Fairbairn, William Ronald Dodds

Flügel, John Carl  
Glover, Edward  
Glover, James  
Great Britain  
Hampstead Clinic  
Heimann, Paula  
Hoffer, William (Wilhelm)  
Hogarth Press  
Imago Publishing Company  
Isaacs-Sutherland, Susan  
Khan, Mohammed Masud Rasa  
Klein-Reizes, Melanie  
Low, Barbara  
Milner-Blackett, Marion  
Money-Kyrle, Roger Earle  
Payne, Sylvia May  
Rees, John Rawlings  
Rickman, John  
Riviere-Hodgson Verrall, Joan  
Robertson, James  
Rosenfeld, Eva Marie  
Rosenfeld, Herbert Alexander  
Rycroft, Charles Frederick  
Sandler, Joseph  
Schmideberg-Klein, Melitta  
Sharpe, Ella Freeman  
Strachey, James Beaumont  
Strachey-Sargent, Alix  
Tavistock Clinic  
Tustin, Frances  
Winnicott, Donald Woods  
Wittkower, Eric

**UNITED STATES**

Alexander, Franz Gabriel  
American Academy of Psychoanalysis  
American Imago  
American Psychoanalytic Association  
Arlow, Jacob A.  
Blanton, Smiley  
Brill, Abraham Arden  
Brunswick, Ruth Mack  
Bullit, William C.  
Burrow, Trigant  
Chicago Psychoanalytic Institute  
Clark-Williams, Margaret  
Doolittle-Aldington, Hilda (H.D.)  
Eissler, Kurt Robert  
Eissler-Selke, Ruth  
Ellenberger, Henri Frédéric  
Erikson, Erik Homburger  
Frink, Horace Westlake  
Gardiner, Muriel M.  
Greenacre, Phyllis

Greenson, Ralph  
 Halberstadt-Freud, Sophie  
 Hartmann, Heinz  
 Horney-Danielson, Karen  
 Jacobson, Edith  
 Jelliffe, Smith Ely  
 Jekels (Jekeles), Ludwig  
 Kardiner, Abram  
 Katan, Maurits  
 Katan-Rosenberg, Anny  
 Kris, Ernst  
 Lehrman, Philip R.  
 Los Angeles Psychoanalytic Institute and Society  
 Lowenstein, Rudolph M.  
 Mahler-Schönberger, Margaret  
 Marcuse, Herbert  
 Mead, Margaret  
 Menninger, Karl A.  
 Meyer, Adolf F.  
 Moreno, Jacob Levy  
 National Psychological Association for Psychoanalysis  
 New York Freudian Society  
 New York Psychoanalytic Institute  
 Nin, Anaïs  
 North America  
 Nunberg, Hermann  
 Putnam, James Jackson  
 Róheim, Géza  
 Rubinstein, Benjamin B.  
 Sachs, Hanns US  
 San Francisco Psychoanalytic Society  
 San Francisco Psychotherapy Research Group and Control-Mastery Theory  
 Schilder, Paul Ferdinand  
 Simmel, Ernst  
 Spitz, René Arpad  
 Sterba, Richard F.  
 Sterba-Radanowicz-Hartmann, Editha Hungary  
 Stoller, Robert J.  
 Stone, Leo  
 Sullivan, Harry Stack  
 Thompson, Clara M.  
 Waelder, Robert  
 Weiss, Edoardo  
 Walter, Bruno  
 Washington Psychoanalytic Society  
 Zetzel-Rosenberg, Elizabeth

**URUGUAY**

Uruguay

**VENEZUELA**

Venezuela

**WEST INDIES**

Fanon, Frantz

**YUGOSLAVIA**

Yugoslavia (ex)

**B) Case histories**

Aimée, the case of  
 Ajase complex  
 Anna O., case of  
 Cäcilie M., case of  
 Elisabeth von R., case of  
 Emmy von N., case of  
*Flower Doll: Essays in Child Psychotherapy*  
 “Fragment of an analysis of a case of hysteria” (Dora, Ida Bauer)  
 Katharina, case of  
 Little Arpád, the boy pecked by a cock  
 Lucy R. case  
 Mathilde, case of

**C) Events**

Clark University  
 Congrès international de l’hypnotisme expérimental et scientifique, First  
 Congress of French-speaking psychoanalysts from Romance-language-speaking countries  
 Controversial Discussions  
 First World War  
 Gestapo  
 Mahler, Gustav (meeting with Sigmund Freud)  
 Second World War

**D) Psychoanalysis and Other Disciplines**

Anthropology and psychoanalysis  
 Cinema and psychoanalysis  
 Cinema criticism  
 Cocaine and psychoanalysis  
 Feminism and psychoanalysis  
 Multilingualism and psychoanalysis  
 Music and psychoanalysis  
 Brain and psychoanalysis, the  
 Catastrophe theory and psychoanalysis  
 Cognitivism and Psychoanalysis  
 Darwin, darwinism and psychoanalysis  
 Death and psychoanalysis  
 Ethnopsychanalysis  
 Ethology and psychoanalysis  
 German romanticism and psychoanalysis  
 Goethe and psychoanalysis  
 Hard science and psychoanalysis

Historical truth  
 History and psychoanalysis  
 Judaism and psychoanalysis  
 Kantianism and psychoanalysis  
 Law and psychoanalysis  
 Linguistics and psychoanalysis  
 Literary and artistic creation  
 Literature and psychoanalysis  
 Marxism and psychoanalysis  
 Monism  
 Mythology and psychoanalysis  
 Phenomenology and psychoanalysis  
 Philosophy and psychoanalysis  
 Politics and psychoanalysis  
 Psychoanalysis  
 Psychoanalytic research  
 Psychoanalytic semiology  
 Psychoanalytic splits  
 Psychology and psychoanalysis  
 Racism, anti-Semitism and psychoanalysis  
 Religion and psychoanalysis  
 Sartre and psychoanalysis  
 Schiller and psychoanalysis  
 Science and psychoanalysis  
 Shakespeare and psychoanalysis  
 Sociology and psychoanalysis, sociopsychanalysis  
 Spinoza and psychoanalysis  
 Structuralism and psychoanalysis  
 Surrealism and psychoanalysis  
 Visual arts and psychoanalysis

**E) Organizations and Institutions**

Allgemeine Ärztliche Gesellschaft für Psychotherapie  
 American Academy of Psychoanalysis  
 American Psychoanalytic Association  
 Armand Trousseau Children’s Hospital  
 Association psychanalytique de France  
 Berliner Psychoanalytische Poliklinik  
 Berliner Psychoanalytisches Institut  
 Burghölzli Asylum  
 British Psycho-Analytical Society  
 Centre Alfred-Binet  
 Centre de consultations et de traitements psychanalytiques Jean-Favreau  
 Centre psychopédagogique Claude-Bernard  
 Chicago Psychoanalytic Institute  
 Collège de psychanalystes  
 Colloque sur l’inconscient  
 Detski Dom

- Deutsches Institut für Psychologische Forschung und Psychotherapie (Institut Göring)
- École de la Cause Freudienne
- Ecole experimentale de Bonneuil
- École Freudienne de Paris (Freudian school of Paris)
- Fédération européenne de psychanalyse
- Federación psicoanalítica de américa latina
- Freud Museum
- Hampstead Clinic
- Goethe Prize
- Hietzing Schule/Burlingham-Rosenfeld
- Hogarth Press
- Hungarian School
- Imago Publishing Company
- Institut Claparède
- Institut Max-Kassowitz
- International Federation of Psychoanalytic Societies
- International Association for the History of Psychoanalysis
- International Psychoanalytical Association
- Internationaler Psychoanalytischer Verlag
- Los Angeles Psychoanalytic Institute and Society
- Lehrinstitut der Wiener psychoanalytischen Vereinigung
- Menninger Clinic
- National Psychological Association for Psychoanalysis
- New York Freudian Society
- New York Psychoanalytic Institute Sainte-Anne Hospital
- Quatrième Groupe (O.P.L.E.), Fourth Group
- Salpêtrière Hospital, La
- Schweizerische Ärztesgesellschaft für Psychoanalyse
- San Francisco Psychoanalytic Society
- San Francisco Psychotherapy Research Group and Control-Mastery Theory
- Société française de psychanalyse
- Société psychanalytique de Genève
- Société psychanalytique de Montréal
- Société psychanalytique de Paris and Institut de psychanalyse de Paris
- Sigmund Freud Archives
- Sigmund Freud Copyrights Limited
- Sigmund Freud Institute
- Sigmund Freud Museum
- Tavistock Clinic
- Tegel (Schloss Tegel)
- Vienna General Hospital
- Vienna, University of
- Washington Psychoanalytic Society
- Wiener psychoanalytische Vereinigung

# CHRONOLOGY

## ΧΡΟΝΟΛΟΓΙΑ

*This chronological list was based upon the 17,000 sources of historical data that I have gathered for over twenty years and upon the articles published in this Dictionary. It can neither presume completion, since my choices were necessarily arbitrary, nor absolute precision, which does not exist in any work of history, no matter the scrutiny and rigor of its author. As with the Dictionary, it will indefinitely remain subject to additions and revisions. It should therefore only be considered as a point of departure for the more thorough research of our vigilant readers, to benefit future publications. —Alain de Mijolla*

DATE	EVENT
1815–1855	<p>December 18, 1815 – Jakob (Kallamon Jacob) Freud, Sigmund Freud's father, son of Schlomo Freud and Peppi [Pesel] (née Hoffmann), is born in Tysmenitz, Galicia (Poland)</p> <p>1833 – Presumed date of birth of Emanuel Freud, Sigmund's half-brother, in Tysmenitz, Galicia (Poland)</p> <p>1834 or 1835 – Presumed date of birth of Philipp Freud, Sigmund's half-brother, in Tysmenitz, Galicia (Poland)</p> <p>August 18, 1835 – Amalie (Amalia, Malka) Nathanson, Sigmund Freud's mother, daughter of Jacob Nathanson and Sara (née Wilenz), born in Brody</p> <p>January 15, 1842 – Josef Breuer born in Vienna (Austria)</p> <p>October 3, 1846 – James J. Putnam born in Boston, Massachusetts (USA)</p> <p>July 29, 1855 – Jakob Freud and Amalie Nathanson marry in Vienna</p> <p>August 18, 1855 – Johann (John) Freud, son of Emanuel Freud and Maria Freud-Rokach, Sigmund's nephew and playmate, born in Freiberg (Moravia)</p>
1856–1860	<p>May 6, 1856 – Sigismund Schlomo born in Freiberg (Moravia) at 6:30 pm, delivered, as all of Emmanuel and Maria's children, by the midwife Căcilia Smolka; circumcised on May 13</p> <p>October 1857 – Julius, Sigmund Freud's first brother, born in Freiberg (died on April 15, 1858 at the age of six months)</p> <p>October 24, 1858 – Wilhelm Fliess born in Arnswalde (Choszczno)</p> <p>December 31, 1858 – Anna, Sigmund's first sister, born in Freiberg</p>

- August 1859–March 1860 – Jakob Freud leaves for Vienna; Amalia, Sigmund, and Anna follow, stopping in Leipzig en route. Emanuel Freud's family emigrates to Manchester (England) with Philipp Freud
- March 21, 1861 – Regine Debora (Rosa) Freud, Sigmund Freud's second sister, fourth child of Jakob and Amalie, born in Vienna
- August 23 – Francisco Franco da Rocha born in Amparo, State of São Paulo (Brazil)
- 1861–1865
- February 12, 1861 – Louise Andreas-Salomé, called "Lou," born in St. Petersburg (Russia)
- March 22, 1861 – Maria (Mitzi) Freud, Sigmund Freud's third sister, fifth child of Jakob and Amalie, born in Vienna
- July 26, 1861 – Martha Bernays, Sigmund Freud's future wife, daughter of Berman Bernays and Emmeline (née Philipps), born in Hamburg
- July 23, 1862 – Esther Adolfine (Dolfi) Freud, Sigmund Freud's fourth sister, sixth child of Jakob and Amalie, born in Vienna
- May 3, 1864 – Pauline Regine (Paula) Freud, Sigmund Freud's fifth sister, seventh child of Jakob and Amalie, born in Vienna
- June 18, 1865 – Minna Bernays, the younger sister of Martha, Sigmund Freud's wife, born in Hamburg
- June 20, 1865 – Josef Freud (Sigmund Freud's uncle) arrested for trafficking counterfeit rubles in Vienna
- October 1865 – Sigmund Freud admitted to the Leopoldstatter Real- and Obergymnasium
- 1866–1870
- April 15 or 19, 1866 – Alexander Gotthold Efraim Freud, Sigmund Freud's brother, eighth and last child of Jakob and Amalie, born in Vienna
- October 13, 1866 – Georg Groddeck born in Bad Kösen an der Saale (Germany)
- March 18, 1868 – Wilhelm Stekel born in Boyan (Bukovnia)
- February 7, 1870 – Alfred Adler, second of six brothers, born in the Viennese suburb of Rudolfsheim (Austria)
- 1871–1875
- August 31, 1871 – Hermine Hug-Hellmuth-Hug von Hugenstein born in Vienna (Austria)
- October 13, 1871 – Paul Federn born in Vienna (Austria)
- August–September 15, 1872 – Along with two school friends (Eduard Silberstein, Horaz Ignaz Rosanes) Freud visits the Fluss family in Freiburg. Freud claims to be in love with Gisela Fluss
- February 23, 1873 – Oskar Pfister born in Zurich (Switzerland)
- March 24, 1873 – Edouard Claparède born in Geneva (Switzerland)
- July 7, 1873 – Sándor Ferenczi born in Miskolc (Hungary), the eighth of eleven children of Baruch Fraenkel (who will adopt the name Bernát Ferenczi), bookseller, printer, concert agent, and Róza Eibenschütz's agent
- July 1873 – Freud is accepted to his *Matura* (excellently "vorzüglich")



- October 1873 – Freud attends the Wiener Universität, at the medizinischen Fakultät
- October 12, 1874 – Abraham A. Brill born in Kanczugv (Austria)
- July 26, 1875 – Carl Gustav Jung born in Kesswill (Switzerland)
- August 1875 – Freud travels to England to the Manchester home of his half-brothers Emanuel and Philipp Freud
- August 28, 1875 – Marco Levi Bianchini born in Rovigo (Italy)
- 1876
- March – Freud studies in Trieste at Karl Claus’s Institute of Comparative Anatomy
- May 24 – Poul Bjerre born in Göteborg (Sweden)
- October – Freud attends the Ernst Brücke Physiologische Institut as “Famulus”
- 1877
- January 4 – Freud’s first publication: “Über den Ursprung der hinteren Nervenwurzeln im Rückenmarke von Ammocoetes (Petromyzon Planeri)” (1877a)
- May 3 – Karl Abraham born in Bremen (Germany)
- October 12 – Nikolai Ossipov born in Moscow (Russia)
- 1878
- January 22 – Ernst Lanzer (the Rat Man) born in Vienna (dies in Russia in 1918)
- May 10 – Mosche Wulff (or Moshe Woolf) born in Odessa (Russia)
- July 27 – August Aichhorn born in Vienna (Austria)
- 1879
- January 1st – Ernest Jones born in Gowerton, Glamorgan, Wales (Great Britain)
- March 12 – Viktor Tausk born in Zsilina (Slovakia)
- 1880
- November 6 – Sylvia May Payne born in Wimbledon, Surrey (Great Britain)
- December – Treatment of Bertha Pappenheim begins (Anna O.) under Josef Breuer
- 1881
- January 10 – Hanns Sachs born in Vienna (Austria)
- March 31 – Freud becomes a medical doctor
- April 5 – Ludwig Binswanger born in Kreuzlingen, canton of Thurgovia (Switzerland)
- April 8 – Carl Müller-Braunschweig born in Braunschweig (Germany)
- June 25 – Felix Boehm born in Riga (Lithuania)
- June 26 – Max Eitingon born in Mohilev (Russia)
- November 28 – Stefan Zweig born in Vienna (Austria)
- 1882
- March 30 – Melanie Klein-Reizes born in Vienna (Austria)
- April – Freud first meets Martha Bernays
- April 4 – Ernst Simmel born in Wroclaw (Poland)
- July 2 – Marie Bonaparte, princess of Greece and Denmark, born in Saint-Cloud (France)
- October – Freud, having given up a career in research, goes to work in different capacities at the General Hospital of Vienna

- November 1 – Ida Bauer (Dora) born (dies in New York in 1945)
- November 12 – Johan H.W. van Ophuijsen born in Sumatra (Dutch East Indies)
- Jean-Martin Charcot is named Professor of the Clinic of Mental Illnesses
- 1883
- June 28 – Joan Riviere-Hogson Verrail born in Brighton (Great Britain)
- July 13 – Josef Breuer tells Freud about the case of Anna O.
- December 24 – Emil Oberholzer born in Zweibrücken (Switzerland)
- 1884
- January 23 – Hermann Nunberg born in Bendzin, Galicia (Poland)
- April 22 – Otto Rank (Rosenfeld) born in Vienna (Austria)
- June 14 – Eugenia Sokolnicka-Kutner born in Varsovia (Poland)
- October 9 – Helene Deutsch-Rosenbach born in Przemysl (Poland)
- 1885
- March 24 – Susan Isaacs-Sutherland born in Bolton, Lancashire (Great Britain)
- April 1885 – Freud’s research and publications on cocaine
- April 28 – Freud tells Martha that he destroyed his old notes, letters, and manuscripts
- June 19 – A traveling stipend is awarded to Freud for a six-month stay in Paris and Berlin
- July 18 – Freud is named Privatdozent in Neuropathology, a decision that will not become official until September 5
- September 15 – Karen Horney-Danielsen born in Hamburg (Germany)
- October 13 – Freud begins his internship under Professor Jean-Martin Charcot at the Salpêtrière Hospital in Paris
- 1886
- February 28–April 3 – Freud leaves Paris for Berlin and an internship with professor Baginsky, at the Clinic of Children’s Diseases, to prepare for his future post at the Kassowitz Clinic in Vienna
- March 28 – Henri Flournoy born in Geneva (Switzerland)
- April 25 – Freud opens his medical practice in Vienna on Easter Day, at No. 7 Rathausstrasse
- May 22 – Angélo Hesnard born in Pontivy, Morbihan (France)
- September 13 – Civil marriage of Sigmund Freud and Martha Bernays at the Wandsbek Rathaus. Brief religious ceremony on September 15
- October 16 – Adelheid Lucy Koch born in Berlin (Germany)
- 1887
- January 6 – Sergei Pankejeff, the Wolf Man, born in Russia on January 6 in the Gregorian Calendar (December 24, 1886, in the Julian Calendar), died in Vienna in 1979
- January 29 – René Spitz born in Vienna (Austria)

- July 9 – Heinrich Meng born in Hohenhurst (Germany)  
 September 7 – Julio Pires Porto-Carrero born in Pernambuco (Brazil)  
 September 26 – James Strachey born in London (Great Britain)  
 October 12 – Karl Landauer born in Munich (Germany)  
 October 16 – Mathilde Freud (first child of Sigmund and Martha) born in Vienna, Maria-Theresienstrasse 8  
 November 10 – Arnold Zweig born in Glogau (Silesia)  
 November 24 – Freud's first letter to Wilhelm Fliess
- 1888  
 January 13 – Edward Glover born in Lesmahagow, Scotland (Great Britain)  
 May 12 – Theodor Reik born in Vienna (Austria)
- 1889  
 February 19 – René Allendy born in Paris (France)  
 May 1 – First day of treatment of Emmy von N . . . "Don't move! Don't say anything! Don't touch me!"  
 July 19–August 9 – Freud travels to Nancy to visit Hippolyte Bernheim, then to Paris  
 August 8–12 – First International Congress of Experimental Hypnotism and Therapy in Paris, for which Freud is registered  
 August 11 – William R. Fairbairn born in Edinburgh, Scotland (Great Britain)  
 September 21 – Edoardo Weiss born in Trieste (Italy)  
 October 23 – Frieda Fromm-Reichmann born in Karlsruhe (Germany)  
 November 13 – Imre Hermann born in Budapest (Hungary)  
 December 6 – Jean Martin Freud (second child of Sigmund and Martha) born in Vienna, Maria-Theresia-Str. 8  
 Clark University founded (USA); Stanley Hall (1844–1924) is named president
- 1891  
 January 22 – Franz Alexander born in Budapest (Hungary)  
 February 19 – Oliver Freud (third child of Sigmund and Martha) born in Vienna, Maria-Theresia-Str. 8  
 May 2 – Freud publishes his first book, dedicated to Breuer, *Zur Auffassung der Aphasien* (Towards an Interpretation of Aphasia)  
 August 17 – Abram Kardiner born in New York (USA)  
 September – The Freud family moves to 19 Berggasse, where they will reside until 1938  
 September 12 – Géza Róheim born in Budapest (Hungary)  
 October 11 – Dorothy Burlingham-Tiffany born in New York (USA)
- 1892  
 March 7 – Siegfried Bernfeld born in Lemberg, Galicia (Poland)  
 April 6 – Ernst Freud (fourth child of Sigmund and Martha) born in Vienna, 19 Berggasse  
 May 6 – Jacob Freud gives Sigmund the second volume of the Philippon Bible for his thirty-fifth birthday

- June 28 – First letter in which Freud uses the familiar “you” with Wilhelm Fliess
- October – In the case of Frl E. von R., Freud renounces hypnotism and creates the “concentration technique” for what he calls “psychic analysis”
- November 8 – Therese Benedek born in Budapest (Hungary)
- 1893
- February – Translated in Spanish in the Barcelona *Medical Sciences Review*, volume XIX, no. 3, “Psychic Mechanisms of Hysterical Phenomena: Preliminary Communication.” The article is also published in the *Gaceta Médica de Granada* (“Grenada Medical Gazette”), volume XI, 232 and 233. According to James Strachey, it’s “the very first publication of a translation of a psychological work by Freud in the world”
- April 12 – Sophie Freud (fifth child of Sigmund and Martha) born in Vienna, 19 Berggasse
- July 22 – Karl A. Menninger born in Topeka, Kansas (USA)
- July 29 – Pierre Janet defends his medical thesis in Paris: “Contribution to the Study of Mental Accidents Among the Hysterical”
- August 16 – Jean-Martin Charcot dies suddenly in Quarré-les-Tombes in the Morvan (France)
- October 3 – Clara M. Thompson born in Providence, Rhode Island (USA)
- 1894
- April – Frederick W. H. Myers reports on the “Preliminary Communication” during a session at the Society for Psychological Research (London). Jones states that this report was the basis for his interest in Freud’s work (Great Britain)
- April 20 – Edward Bibring born in Stanislaw, Galicia (Poland)
- May 3 – Phyllis Greenacre born in Chicago, Illinois (USA)
- August 2 – Raymond de Saussure born in Geneva (Switzerland)
- November 4 – Heinz Hartmann born in Vienna (Austria)
- November 5 – René Laforgue born in Thann, Alsace (Germany)
- William James writes a summary of the “Psychic Mechanisms of Hysterical Phenomena: Preliminary Communication” in the *Psychological Review* (USA)
- 1895
- February – Wilhelm Fliess operates on Emma Eckstein, Freud’s patient, and forgets a dressing in the operating room
- March 4 – First account of a dream as “wish fulfillment,” Rudi Kaufmann’s dream on sleeping (Frau Breuer’s nephew)
- May 15 – Freud and Josef Breuer publish *Studies on Hysteria*
- July 24 – Freud’s first complete analysis of one of his own dreams about “the injection given to Irma” on the night of July 23–24 during his vacation at the Bellevue Hotel, near Vienna
- August – Freud goes to Italy for the first time, accompanied by his brother Alexander

- September 21 – While returning to Berlin in the train, after a meeting with W. Fliess, Freud edits the beginning of the “Outline of a Scientific Psychology”
- November 29 – Minna Bernays, Martha’s sister, comes to stay with the Freuds and remains with them until the end of her life
- December 3 – Anna Freud, sixth and last child of Sigmund and Martha, born in Vienna, 19 Berggasse
- 1896
- March 30 – First appearance of the word “psycho-analysis” in an article by Freud in French on “L’Hérédité et l’étiologie des névroses” (Heredity and Etiology of Neuroses) in the *Revue neurologique* (1896a)
- April 7 – Donald W. Winnicott born in Plymouth (Great Britain)
- October 23 – Jakob Freud dies after four months of illness. He is buried two days later (dream: “We are asked to close our eyes/an eye”)
- December 3 – Michael Balint (Bàlint, Mihály) born in Budapest (Hungary)
- 1897
- January – Freud’s first four dreams of Rome date from January of this year
- March 27 – Wilhelm Reich born in Dobrzycynica, Galicia (Poland)
- May 10 – Margaret Mahler-Schönberger born in Sopron (Hungary)
- July – Beginning of Selbstanalyse (self-analysis)
- July 17 – Heisaku Kosawa born in Atsugi, Kanagawa (Japan)
- September 8 – Wilfred R. Bion born in Mattra (United Provinces, India)
- September 21 – Cesare Musatti born in Dolo, Venice (Italy)
- September 21 – Letter to Wilhelm Fliess: “I don’t believe anymore in my neurotica”
- September 23 – Freud joins the B’nai-B’rith-Gesellschaft
- September 26 – Max Schur born in Stanislav (Ivano-Frankovsk, Ukraine)
- October 15 – Letter to Wilhelm Fliess: first mention of the future “Oedipus complex”
- December 2 – Otto Fenichel born in Vienna (Austria)
- December 5 – First conference on dreams at the B’nai-B’rith-Gesellschaft
- December 22 – Nicola Perrotti born in Penne, Pescara (Italy)
- December 25 – In Breslau Freud meets with Wilhelm Fliess, who talks to him about bisexuality and bilaterality
- 1898
- February 9 – Rudolph M. Loewenstein born in Lodz (Poland)
- February 9 – “I am giving up self-analysis to devote myself to a book on dreams” writes Freud to W. Fliess
- May 6 – Richard F. Sterba born in Vienna (Austria)
- August 21 – John Rittmeister born in Hamburg (Germany)

- September 22 – First analysis, written to Wilhelm Fliess, on forgetting the name of Signorelli, the painter of the “Last Judgment” in Orvieto
- 1899
- January 11 – Grete Bibring-Lehner born in Vienna (Austria)
- February 3 – Paula Heimann-Glatzko born in Danzig (Germany)
- July 20 – Edmund Bergler born in Austria
- August 6 – Werner Kemper born in Hilgen, Rhenania (Germany)
- August 27 – Final writing and first corrections to the drafts of *The Interpretation of Dreams*
- September 11 – The manuscript of *The Interpretation of Dreams* is delivered to the printer
- October 24 – Date of the dedication in the copy of *The Interpretation of Dreams* sent to Wilhelm Fliess: “Seinem theuern Wilhelm z. 24 OKT 1899”
- November 27 – Durval Marcondes born in São Paulo (Brazil)
- 1900
- January 8 – “The new century, which interests us especially owing to the fact that it includes in itself the date of our death, only brought me a stupid report in the Zeit,” wrote Freud to Wilhelm Fliess
- March 23 – Erich Fromm born in Frankfurt (Germany)
- April 24 – Freud gives a conference on *Fécondité* by Emile Zola before the B’nai-B’rith-Gesellschaft
- April 26 – Ernst Kris born in Vienna (Austria)
- May 27 – Marianne Kris-Rie born in Vienna (Austria)
- September 24 – “I’m slowly writing the ‘Psychopathology of Everyday Life,’” writes Freud to Wilhelm Fliess
- October 14 – The beginning of Dora’s treatment announced; it ends on December 31
- 1901
- April 14 – Jacques Lacan born in Paris (France)
- August 7 – “You side against me saying that ‘he who read the thoughts of others only finds his own thoughts,’ which takes away all validity from my research,” Freud writes to Wilhelm Fliess, their distance more pronounced day by day.
- August 30–September 14 – Freud’s first trip to Rome accompanied by his brother Alexander
- September 23 – Sacha Nacht born in Racacini, Bacau (Romania)
- November 23 – Muriel M. Gardiner born in Chicago, Illinois (USA)
- The *Archives de psychologie* founded in Geneva by Edouard Claparède and his uncle Théodore Flournoy (Switzerland)
- Freud publishes *Zur Psychopathologie des Alltagslebens (Über Vergessen, Versprechen, Vergreifen, Aberglaube und Irrtum)* (The Psychopathology of Everyday Life, 1901b)
- 1902
- March 5 – Freud is named “outstanding professor”
- March 11 – Freud’s last letter to Wilhelm Fliess before Swoboda affair in 1904

- April 9 – Annie Reich-Pink born in Vienna (Austria)  
 June 15 – Erik Homburger Erikson born in Frankfurt (Germany)  
 October – Freud sends postcards inviting Alfred Adler, Wilhelm Stekel, Max Kahane, and Rudolph Reitler to scientific meetings entitled “Psychological Wednesday Society” (“*Psychologischen Mittwoch-Vereinigung*”). Alfred Meisl and Paul Federn will join him in 1903
- 1903
- February 14 – Marriage of Carl G. Jung and Emma Rauschenbach  
 June – Otto Weininger’s book, *Geschlecht und Charakter* (Sex and Character) published. He commits suicide on October 4  
 August 11 – Celes Ernesto Cárcamo born in La Plata (Argentina)  
 August 28 – Bruno Bettelheim born in Vienna (Austria)  
 August 3 – Daniel Lagache born in Paris (France)
- 1904
- April 26 – Freud resumes contact with Wilhelm Fliess, but Fliess later accuses Freud of being at the source of the plagiarism of his discovery on bisexuality, for which Hermann Swoboda is later found guilty  
 June 24 – Angel Garma born in Bilbao (Spain)  
 August 14 – Emilio Servadio born in Sestri, Genoa (Italy)  
 August 17 – Sabina Spielrein is admitted to the Burghölzli Shelter, where she will be treated by Jung in a method inspired by Freud (Switzerland)  
 September 4 – Freud’s improvised voyage with his brother Alexander in Greece. Trip to the Acropolis in Athens
- 1905
- Eduard Hitschmann joins the “*Psychologischen Mittwoch-Vereinigung*”  
 Otto Rank and Eugen Bleuler write to Freud  
 Publication of two books by Freud: *Der Witz et seine Beziehung zum Unbewußten* (The Joke and its Relationship with the Unconscious, 1905c), *Drei Abhandlungen zur Sexualtheorie* (Three Essays on the Theory of Sexuality, 1905d), and of two articles, “*Über Psychotherapie*” (On Psychotherapy, 1905a) and “*Bruchstück einer Hysterie-Analyse*” (Dora: An Analysis of Case of Hysteria, 1905e), begun in 1901  
 Ragnar Vogt, future leading professor of psychiatry in Norway, draws on Freud’s psycho-cathartic method in *Psykiatriens grundtræk* (Outline of Psychiatry) (Norway)
- 1906
- February – First article on psychoanalysis in the USA written by James J. Putnam in the *Journal of Abnormal Psychology* (USA)  
 April 11 – Carl Gustav Jung’s first letter to Freud  
 May 8 – In Freud’s letter to Arthur Schnitzler: “I have often asked myself with astonishment where you gather knowledge of such and such a hidden point, when I only acquired it after tedious investigative work, and I came to envy the writer that I already admired.”  
 September – Freud’s *Sammlung kleiner Schriften zur Neurosenlebre aus den Jahren 1893–1906*, Volume I (Collection of Articles on Neuroses, Dating from 1893 to 1906) published

1907

October 10 – First meeting of the Psychological Wednesday Society where Otto Rank “functions as paid secretary.” The sessions take place every Wednesday at 8:30 pm at Freud’s home. The conferences begin at 9:00 pm. The order of the speakers in the discussion is determined by drawing lots.

January 1 – After the publication of *Psychologie der Dementia praecox* by Carl G. Jung, Freud writes to him: “Please quickly renounce this error that your writing on dementia praecox did not very much please me. The simple fact that I expressed criticism can prove it to you. Since, if it were otherwise, I would find sufficient diplomacy to hide it from you. It would really be wiser to go against the best that were ever associated with me. I see, in reality, in your essay on d. pr. the most important and rich contribution to my work that I have come across, and I don’t see among my students in Vienna, who probably have a non univocal advantage over you from personal contact with me, in fact only one can put himself on the same rank as you for comprehension, and none are up to do as much for the cause as you, and ready to do it.”

January 30 – Max Eitingon visits Freud, with a patient

February 26 – John Bowlby born in London (Great Britain)

March 3 – Carl G. Jung and Ludwig Binswanger’s first visit with Freud on Sunday, March 3 at 10:00 am

June 8 – Edouard Claparède, the director of the laboratory of experimental psychology in Geneva, visits Carl G. Jung to be introduced to the technique of association (Switzerland)

June 25 – Enrique Pichon-Rivière born in Geneva (Switzerland)

June 25 – Karl Abraham’s first letter to Freud

July 4 – First reading in France of “The Psycho-Analytical Method and Freud’s ‘*Abwehr Neuropsychosen*’” by Adolf Schmiergeld and P. Provotelle during the session of the Neurology Society in Paris

September 2–7 – First International Congress of Psychiatry, Psychology and Assistance for the Insane in Amsterdam. Carl G. Jung responds to attacks against Freud (Netherlands)

September 27 – First session of the Freud-Gesellschaft in Zurich, founded by Carl G. Jung (Switzerland)

October 1 – First consultation of the Rat Man

October 9 – Freud announces his intention to dissolve the Psychological Wednesday Society to create the Vienna Psychoanalytical Society

November 6 – Freud presents the case of the Rat Man to the Vienna Psychoanalytical Society and Otto Rank notes: “The technique of the analysis has changed in the sense that the psychoanalyst no longer seeks to obtain the material that interests himself, but allows the patient to follow the natural and spontaneous course of his thoughts”

December 15 – Karl Abraham’s first visit with Freud

*Studie über Minderwertigkeit von Organen* (Study on the Inferiority of Organs) by Alfred Adler published (Austria)



- 1908
- February 2 – Sándor Ferenczi, accompanied by Fülöp Stein, visits Freud for the first time
  - April 15 – The Wiener Psychoanalytische Vereinigung (Vienna Psychoanalytical Society) founded
  - April 26–27 – Zusammenkunft für Freudsche Psychologie, first international congress on Freudian psychology in Salzburg, a meeting suggested by Carl G. Jung. Freud's conference on the Rat Man lasts four hours
  - April 30 – Ernest Jones and Abraham A. Brill visit and lunch with Freud in Vienna
  - May 3 – Freud's first letter to Stefan Zweig
  - May 8 – Cyro Martins born in Porto Alegre (Brazil)
  - June 2 – Kurt Eissler born in Vienna (Austria)
  - August 27 – First meeting of the Berlin Psychoanalytical Association founded by Karl Abraham with Iwan Bloch, Magnus Hirschfeld, and Otto Juliusburger (Germany)
  - September 2–15 – Freud travels to England to visit his elder brothers
  - September 20 – Alexander Mitscherlich born in Munich (Germany)
  - September 26 – Ernest Jones settles in Toronto at the Toronto Lunatic Asylum (Canada)
  - October 3 – Ignacio Matte-Blanco born in Santiago (Chile)
  - November 6 – Françoise Dolto-Marette born in Paris (France)
  - Nikolai Ossipov meets Freud in Vienna. He edits the translations of Freud's works and founds the first psychoanalytical circle in Moscow, the "little Fridays" (Russia)
  - Ludwig Jekels edits the first publications of Freud in the Polish language (Poland)
  - Nervöse Angstzustände und ihre Behandlung* (Nervous Anxiety States and Their Treatment) by Wilhelm Stekel published (Austria)
- 1909
- January 18 – Freud's first letter to Oskar Pfister
  - February 7 – Marriage of Mathilde, the first of Freud's children to marry, to Robert Hollitscher
  - March – First half-volume of the *Jahrbuch für psychopathologische und psychoanalytische Forschungen*. Directors: Eugen Bleuler and Freud. Editor-in-chief: Carl G. Jung
  - March 10 – Alfred Adler gives a conference at the Vienna Society: "From Psychology to Marxism"
  - April 25 – Oskar Pfister's first visit with Freud
  - May 30 – Sabina Spielrein's first letter to Freud for an interview on the subject of his relationship with Carl G. Jung
  - July 2 – Pieter van der Leeuw born in Zutphen (Netherlands)
  - August 27 – Freud, Carl G. Jung and Sándor Ferenczi arrive in New York, at the invitation of G. Stanley Hall. Freud is named Doctor Honoris Causa at Clark University (Worcester, Massachusetts) where he gives, beginning on September 6, five conferences on psychoanalysis. On November 9, 1909, Putnam writes to him: "Your visit to America had a profound impact on me; I work and I read your writings with an even greater interest." (USA)

October 16 – Jeanne Lampl-de Groot born in Schiedam (Netherlands)

November 17 – Correspondence begins between Freud and James Jackson Putnam

Study Group in Sydney founded by Dr. Donald Frazee (Australia)

First article on psychoanalysis written by a Spanish psychiatrist, Dr. Gayarre, “Sexual Origin of Hysteria and General Neurosis,” published in the *Clinical Review of Madrid* (Spain)

*Psychoterapia (Psixoterapija – Obozrenie voprosov lecenija i prikladnoj psixologii)* founded. It is published until 1917 (Russia)

Freud publishes “Analyse der Phobie eines fünfjährigen Knaben (Der kleine Hans)” (Little Hans) 1909b, first study of the case from which the clinical material, originating from the cure of a child by his father, Max Graf, confirms the Freudian theories of child sexuality

Freud publishes “Bemerkungen über einen Fall von Zwangsneurose (Der Rattenmann)” (Remarks on a Case of Obsessional Neurosis (The Rat Man), 1909d)

*Der Mythos der Geburt des Helden. Versuch einer psychologischen Mythendeutung (The Myth of the Birth of the Hero)* by Otto Rank published (Austria)

*Traum und Mythos. Eine Studie zur Völkerpsychologie. Schriften zur angewandten Seelenkunde (Dreams and Myths)* by Karl Abraham published (Germany)

1910

February – Beginning of the first analysis of the “Wolf Man,” Sergei Konstantinovich Pankejeff. It concludes on July 14, 1914

March 30 – First public definition of countertransference in Freud’s conference at the Nuremberg Congress: “Our attention is directed to the ‘counter-transference’ which registers with the physician as a consequence of the influence the patient exerts upon the unconscious feelings of his analyst. We are all ready to require that the physician recognizes and controls in himself this counter-transference.” (1910d)

March 30 – Berliner Psychoanalytische Vereinigung (Berlin Psychoanalytic Society) founded (Germany)

March 30–31 – 2nd Congress of the International Psychoanalytical Association in Nuremberg (Germany) during which the International Psychoanalytical Association is founded with its headquarters in Zurich (Switzerland). President: Carl G. Jung. Secretary: Franz Riklin. The existing psychoanalytical associations become local branches. Its official monthly mouthpiece, the *Korrespondenzblatt*, founded. The *Zentralblatt für Psychoanalyse; Medizinische Monatsschrift für Seelenkunde* (Central sheet for psychoanalysis; Medical monthly for Psychology) is founded; Freud is the editor-in-chief and the editors are Alfred Adler and Wilhelm Stekel

April – The Wiener Psychoanalytische Vereinigung (Vienna Psychoanalytical Society) leaves Freud’s residence and meets at Doktorenkollegium, Rothenturmstr. 19 (Austria)

April 10 – Margarethe Hilferding-Hönigsberg becomes the first female member of the Viennese Psychoanalytical Society (Austria)

May 2 – The American Psychopathological Association founded by Ernest Jones, in conjunction with A.A. Brill, August Hoch, Morton Prince, and James Putnam. President: Morton Prince (USA)

July 2 – Herbert Rosenfeld born in Nuremberg (Germany)

August 23 – Freud's letter to Poul Bjerre (Sweden) marks the beginning of their correspondence

August 30 – Freud "analyzes" Gustav Mahler during his stay in Leiden (Holland)

September 24 – Arminda Aberastury born in Buenos Aires (Argentina)

October 12 – Alfred Adler is elected president and Wilhelm Stekel vice-president of the Viennese Psychoanalytical Society (Austria)

December – Freud's first letter from France, from Dr. Pierre Morichau-Beauchant, in Poitiers: "This letter will show you that you also have disciples in France who passionately follow your work" (France)

Germán Greve Schlegel publishes the first psychoanalytical article known in Latin America, in Chile: "Sobre Psicología y Psicoterapia de Ciertos Estados Angustiosos." The presentation of this study in Buenos Aires in 1910 was noted by Freud in the *Zentralblatt für Psychoanalyse* (1911) and in *Contribution to the History of the Psychoanalytical Movement* (1914d) (Chile)

The term *Oedipus complex* appears in Freud's article entitled "Contribution to the Psychology of Love" (1910h)

The Flexner report, underlining the lack of teaching standards in teaching medicine, is published in America. It becomes one of the bases for refusing non-doctors in American psychoanalytical associations (USA)

Freud publishes *Über psychoanalyse* (Five Lectures on Psycho-Analysis, 1910a), deriving from conferences given in the United States

Freud publishes *Eine Kindheitserinnerung des Leonardo da Vinci* (Leonardo da Vinci and a Memory of His Childhood, 1910c)

1911

January – Psychoanalytical group in Munich founded by Leonhard Seif (Germany)

January 17 – Poul Bjerre gives a conference on "Freud's Psychoanalytical Method" before the Association of Swedish Doctors (Sweden)

February 12 – New York Psychoanalytic Society founded by Abraham A. Brill with fifteen physicians, in opposition to the American Psychoanalytic Association that Ernest Jones founds in May (USA)

February 22 – Alfred Adler and Wilhelm Stekel resign from their posts at the head of the Vienna Society; Freud resumes the presidency with Eduard Hitschmann as vice-president and Hanns Sachs as librarian

May – Jan van Emden and August Stärke visit Freud (Holland)

May 2 – Leonid Drosnes visits Freud (Odessa)

May 9 – American Psychoanalytic Association founded in Baltimore by Ernest Jones with James Putnam and eleven members, the majority physicians (USA)

June – Alfred Adler leaves the Vienna Psychoanalytical Society (Wiener Psychoanalytischen Vereinigung). Nine members and the editorial staff of *Zentralblatt* follow suit in July (Austria)

June 28 – First psychoanalytical lecture addressed to the medical community by David Eder at a conference of the British Medical Association: while he speaks, the audience leaves (Great Britain)

August 14 – Maurice Bouvet born in Eu, Seine Maritime (France)

September – Sigmund Freud writes “On Psycho-Analysis” (1913n [1911]), at the request of Andrew Davidson, secretary of the Branch of Psychological Medicine and Neurology at the Australian Medical Congress in Sydney (Australia) where, in addition, lectures are given by Carl G. Jung and Havelock Ellis

September 20 – Ralph Greenson born in Brooklyn, New York (USA)

September 21–22 – 3rd Congress of the International Psychoanalytical Association in Weimar (Germany). President: Carl G. Jung

October 30 – Emma Jung writes to Freud about the uneasiness between her and her husband since the publication in the *Jahrbuch* of the beginning of “Wandlungen und Symbole der Libido” (Metamorphosis and Symbols of the Libido) by Carl G. Jung

December – Eugen Bleuler resigns from the International Psychoanalytical Association

Freud, A. Einstein, D. Hilbert, E. Mach, etc., sign a Call (*Aufruf*) for the creation of an association to express positivist philosophy

1912

March – *Imago. Zeitschrift für die Anwendung der Psychoanalyse auf die Geisteswissenschaften* founded (1912–1941). Editorial Director: Sigmund Freud. Editors-in-chief: Otto Rank and Hanns Sachs

July 30 – Ernest Jones suggests, at Sándor Ferenczi’s instigation, the founding of a Secret Committee excluding Carl G. Jung and including as members himself, Freud, Karl Abraham, Ferenczi, Otto Rank, Hanns Sachs, and, starting in 1919, Max Eitingon

September – Carl G. Jung is invited by Smith Ely Jelliffe to give nine conferences at Fordham University, in New York (USA)

September 3 – Jacob A. Arlow born in New York (USA)

September 27 – Lou Andreas Salomé first letter to Freud

November 6 – Wilhelm Steckel resigns from the Vienna Psychoanalytical Society (Austria)

November 24 – Presidents’ conference in Munich: Carl G. Jung and Franz Riklin for the IPA, Freud, Ernest Jones, Karl Abraham, and J.H.W. van Ophuijsen. Freud faints (Germany)

December 18 – Carl G. Jung’s letter to Freud marks the rupture: “I am in fact not at all neurotic—good thing (. . .) You know well how far the patient can go in his self-analysis, he doesn’t come out of his neurosis—like you. One day when you will be completely freed from complexes and you no longer play the father towards your sons, in whom you constantly sight the weaknesses, that you will put yourself into that position, then I want to

1913

reverse myself and eliminate all at once the sin of my disagreement with you.”

Jean-Jacques Rousseau Institute founded in Geneva by Edouard Claparède (Switzerland)

January 15 – To replace the *Zentralblatt für Psychoanalyse*, the *Internationale Zeitschrift für ärztliche Psychoanalyse* is founded at the instigation of S. Ferenczi and O. Rank

May 19 – Budapest Psychoanalytic Society founded by Sándor Ferenczi. President: S. Ferenczi, Vice-president: I. Hóllós, Secretary: S. Rádo, Treasurer: Lajos Lévy (Hungary)

May 25 – First meeting of the Secret Committee. Freud offers to each a Greek intaglio taken from his own collection that they will have mounted in signet rings. Ernest Jones is the president

August 5 – Carl G. Jung uses the expression “analytical psychology” for the first time in a conference (“General Aspects of Psychoanalysis”) before the London Psycho-medical Society (Great Britain)

August 6–12 – 17th International Medical Congress in London. Confrontation between Pierre Janet and Ernest Jones to whom Freud then wrote: “I will not know how to say how much I was overcome by your report to the Congress and by the way in which you had undone Janet in front of your compatriots” (Great Britain)

September 7–8 – 4th Congress of the International Psychoanalytical Association in Munich. President: Carl G. Jung, who resigns from his post as editor-in-chief of the *Jahrbuch* (Germany)

October – *The Psychoanalytic Review* in New York founded by Smith Ely Jelliffe and William Alanson White, Director of the Government Hospital for the Insane, Washington, DC (USA)

October – Freud publishes *Totem and Taboo* (1912–1913) as a book

October 15 – Frances Tustin born in Darlington (Great Britain)

October 30 – The London Psycho-Analytic Society founded by Ernest Jones. President: E. Jones, Vice-president: Douglas Bryan, Secretary: M. D. Eder

Alfred Adler transforms the Verein für Freie Psychoanalytische Forschung (Society for Psychoanalytical Research), founded after his secession, into Verein für Individualpsychologie (Society for Individual Psychology) (Austria)

A. A. Brill (New York) publishes the first English translation of *The Interpretation of Dreams* (USA)

1914

April 20 – Carl G. Jung resigns from the International Psychoanalytical Association. Karl Abraham is elected as provisional president of the association

May – Boston Psychoanalytic Society founded. President: James Putnam, Secretary: Isador Coriat (USA)

June – Freud publishes “Zur Einführung des Narzißmus” (On Narcissism: An Introduction, 1914c) and “Zur Geschichte der psychoanalytischen Bewegung” (On the History of the Psychoanalytical Movement, 1914d)

- June 28 – The Serbian nationalist Gavrilo Princip assassinates Archduke Franz Ferdinand in Sarajevo
- July 6 – The Washington Psychoanalytic Society founds St. Elizabeth’s Hospital in Washington, DC, with acting president William Alanson White, Hospital Superintendent (USA)
- July 10 – The Zurich local branch (Carl G. Jung, Eugen Bleuler, Alfons Maeder, etc.) vote fifteen to one for its definitive withdrawal from the International Psychoanalytical Association (Switzerland)
- July 28 – Austria-Hungary declares war on Serbia, the first stage of the First World War
- November 2 – Beginning of the First World War
- December – Publication of the *Jahrbuch der Psychoanalyse* is suspended by Deuticke, the editor
- First official recognition of psychoanalysis in Europe with a lecture by Gerbrandus Jelgerma at the University of Leyde (Netherlands)
- Publication of *La psycho-analyse des névroses et des psychoses. Ses applications médicales et extra-médicales* (Psychoanalysis of Neuroses and Psychoses. Their Medical and Extra-Medical Applications) by Emmanuel Régis and Angélo Hesnard, first book in France devoted to psychoanalysis (France)
- 1915
- March–July – Freud works on twelve essays on metapsychology of which only five will be published between 1915 and 1917
- June 10 – Serge Lebovici born in Paris (France)
- September 15 – Freud observes his grandson Ernst Wolfgang Halberstadt, eighteen months old, indulge in the game “fort-da” with a spindle
- October–March 1916 – Last series of conferences during the winter semester at the University published under the title of *Vorlesungen zur Einführung in die Psychoanalyse* (*Introductory Lectures on Psychoanalysis*, 1916–1917a [1915–17]), “in front of an auditorium of around 70 people, among which were two of my daughters and one daughter-in-law,” writes Freud. Otto Fenichel takes part
- Sulla psicoanalisi, Cinque Conferenze sulla psicoanalisi*, the first work of Freud translated into Italian by Marco Levi Bianchini published for the “Biblioteca Psichiatrica Internazionale” (Italy)
- Genserico Pinto publishes his thesis, *Da Psicanálise. A sexualidade das Neuroses*, in Rio de Janeiro (Brazil)
- 1916
- February 28 – Danilo Perestrello born in Rio de Janeiro (Brazil)
- May 6 – Freud’s sixtieth birthday, celebrated discreetly because of the war. Edouard Hitschmann gives him an “undelivered speech”
- September 15 – Serge Viderman born in Rimnic-Sarat (Romania)
- 1917
- March 24 – Neederlandsche Vereeniging voor Psychoanalyse (Netherlands Society for Psychoanalysis) founded by Gerbrandus Jelgersma, Jan van Emden, Johan H.W. van Ophuijsen, and Johann Stärke (Netherlands)

- May 27 – Georg Groddeck’s first letter to Freud, who replies on June 5: “Whoever recognized that transference and resistance constitute the pivot of treatment belong forever to our uncivilized horde”
- November 7 – The Bolsheviks take power in Russia (October Revolution)
- Ruíz Castillo, at the suggestion of José Ortega y Gasset, buys the publishing rights for the complete works of Sigmund Freud in Spanish, past and future. López Ballesteros is responsible for the translation (Spain)
- Geza Róheim publishes in *Imago* the first psychoanalytical article written by an anthropologist, “Spiegelzauber” (The Magic Mirror), an excerpt of a book that will be published in 1919
- 1918
- March 11 – Pierre Marty born in St. Céré, Lot (France)
- September 28–29 – 5th Congress of the International Psychoanalytical Association, in the Great Room of the Academy of Sciences of Hungary, in Budapest (Hungary). Freud’s conference: “Wege der psychoanalytischen Therapie” (Paths of Psychoanalytical Therapy). Sándor Ferenczi is elected president of the IPA but the political situation in Hungary will lead Ernest Jones to succeed him in October 1919 as “acting president”
- November 4 – James Jackson Putnam dies in Boston, Massachusetts (USA)
- November 11 – The Armistice ends the First World War
- December 3 – In the name of the foundation created by Anton von Freund, Freud awards a medical prize for the article by Karl Abraham on the pregenital phase of the libido, in part, as well as for the brochure by Ernst Simmel on the neuroses of war, and the Imago prize for the article by Theodor Reik on the puberty rites of primitive societies
- The *Revista de Psiquiatria y Disciplinas Conexas*, founded by Hermilio Valdizán and Honorio Delgado in Lima (Peru)
- Freud publishes “Aus der Geschichte einer infantilen Neurose” (From the History of an Infantile Neurosis, The Wolf Man, 1918b [1914])
- 1919
- January 15 – The publishing house Internationaler Psychoanalytischer Verlag founded. Editorial Board: S. Freud, S. Ferenczi, A. von Freund, and O. Rank. Otto Rank is the director of the organization; Theodor Reik, assistant.
- February 20 – British Psycho-Analytical Society founded by Ernest Jones (Great Britain)
- March 24 – Schweizerische Gesellschaft für Psychoanalyse (Swiss Society for Psychoanalysis) founded by Oskar Pfister, Ludwig Binswanger, Herman Rorschach, Emil and Mira Oberholzer, etc. (Switzerland)
- April 29 – Sándor Ferenczi receives his nomination as professor with the creation of the first Psychoanalysis Chair at the University of Budapest. In August, the Miklós Horthy’s anti-Semitic government removes Ferenczi from this post, then from the management of the Batizfalvy Sanatorium on May 28, 1920. He will finally be expelled from the Royal Association of Medicine in Budapest for “collaboration with the Bolsheviks” (Hungary)
- July 3 – Viktor Tausk commits suicide in Vienna (Austria)

October – Max Eitingon becomes a member of the Secret Committee

Kinderheim Baumgarten founded by Siegfried Bernfeld. Nearly three hundred Polish-Jewish refugees, boys and girls, are taken in, a model for future psychoanalytical teaching institutions (Germany)

Geneva Psychoanalytical Circle founded by Edouard Claparède, who becomes president (Switzerland)

Tatiana Rosenthal becomes director of the Polyclinic for the Treatment of Psychoneuroses in connection with the V. Bechterev Research Institute in St. Petersburg (Russia)

“Über die Entstehung des Beinflussungsapparate in der schizophrenie” (On the Origin of the “Influencing Machine” in Schizophrenia) by Viktor Tausk published (Austria)

*Tagebuch eines halbwüchsigen Mädchens (A Young Girl's Diary)* by Hermine von Hug-Hellmuth published (Austria)

1920

January 25 – Freud's daughter, Sophie Halberstadt, dies during the epidemic of the Spanish flu

February 14 – Poliklinik für psychoanalytische Behandlung nervöser Krankheiten (Polyclinic for Psychoanalytical Treatment of Mental Illness), known as the Berliner Poliklinik (Berlin Polyclinic), situated at 29 Potsdamerstrasse, founded by Max Eitingon, Ernst Simmel, and Karl Abraham. It was arranged by Ernst Freud (Germany)

September – Genfer Psychoanalytische Gesellschaft (Geneva Psychoanalytic Society), founded with the participation of Pierre Bovet, Henri Flournoy, Charles Odier, Pierre Morel, Sabina Spielrein, W. Boven, and Raymond de Saussure. President: Edouard Claparède (Switzerland)

September 8–11 – 6th Congress of the International Psychoanalytical Association in The Hague (Netherlands). President: Ernest Jones (acting president), Introduction by Freud “Ergänzungen zur Traumlehre” (Additions to the Dream Doctrine)

September 20 – Beginning of the 361 *Rundbriefe* (circular letters) exchanged between the members of the Secret Committee until March 14, 1926

October 15 – Meeting of the Kommission für Kriegsneurosenbehandlung (Commission for the Treatment of War Neuroses). Freud presents his expertise

December – Publication of Freud's first book translated into French, “Five Lectures from 1909,” under the title “Origin and Development of Psychoanalysis” in the *Geneva Review*. Translator is Yves Le Lay and the preface is by Edouard Claparède. (Switzerland)

Melanie Klein's first publication “Der Familienroman in Statu Nascendi” in the *Internationale Zeitschrift für Psychoanalyse*

The Italian review *Archivio generale di neurologia, psichiatria e psicoanalisi* and the American journal *Psyche and Eros* founded (Italy–USA)

*O pansexualismo na doutrina de Freud* by Franco da Rocha, first professor of neuro-psychiatry at the Medical School of São Paulo, published (Brazil)



- The Tavistock Clinic, 51 Tavistock Square, Bloomsbury, London, founded by Crichton-Miller (Great Britain)
- International Journal of Psycho-Analysis*, the English publication of *Die Internationale Zeitschrift für Aerztliche Psychoanalyse*, and of the “Glossary Committee,” with Joan Riviere, James and Alix Strachey, with an eye to the future *Standard Edition*, founded by Ernest Jones (Great Britain)
- “Biblioteca Psicoanalitica Internazionale” founded by Marco Levi Bianchini (Italy)
- Freud publishes *Jenseits des Lustprinzips* (Beyond the Pleasure Principle, 1920g)
- 1921
- March – Eugénie Sokolnicka, Polish psychoanalyst analyzed by S. Ferenczi and Freud, establishes herself in Paris with Freud’s endorsement (France)
- April 18 – Franco Fornari born in Rivergaro, Piacenza (Italy)
- August – Detski Dom (Children’s Home) founded in Moscow, under the authority of Ivan Ermakov, President of the Society and of the Psychoanalytical Institute, but directed by Vera Schmidt. Sabina Spielrein practices there upon their return to Russia in 1923 (Russia)
- August 6 – Freud publishes *Massenpsychologie und Psychoanalyse des Ich* (*Group Psychology and the Analysis of the Ego*, 1921c)
- André Breton visits Freud in Vienna (France)
- The New Library of Psycho-Analysis founded by Ernest Jones. The publication is ensured by Leonard and Virginia Woolf at the Hogarth Press (Great Britain)
- A psychoanalytical association founded in Moscow with Vera and Otto Schmidt, Ivan Ermakov, Mosche Wulff, I.W. Kannabich, Alexander Riom Luria. It was not be recognized at the 7th Congress of the IPA (Russia)
- 1922
- January 22 – Indian Psycho-Analytical Society in Calcutta founded by Girindrasekhar Bose (India)
- February 20 – Berliner Psychoanalytische Institut (BPI) (Berlin Psychoanalytical Institute) founded, comprised of the polyclinic, a training institute (conferences, seminars on case studies, didactic and controlled analyses) and a commission on the cursus (Germany)
- May 14 – Freud’s letter to Arthur Schnitzler: “I think that I avoided you from a kind of fear of meeting my double”
- May 22 – Lehrinstitut der Wiener Psychoanalytischen Vereinigung (“Ambulatorium,” the Vienna psychoanalytical polyclinic) opens under Eduard Hitschmann’s direction (Austria)
- June 13 – Anna Freud becomes a member of the Vienna Psychoanalytical Society
- July 25 – François Perrier born in Paris (France)
- August 13 – Willy Baranger born in Bône (Algeria)
- September – A psychoanalytical work group is created in Leipzig around Therese Benedek (Germany)
- September 25–27 – Seventh Congress of the International Psychoanalytical Association in Berlin (Germany). President: Ernest Jones. A prize is created for a competition whose subject is: “Relationship of analytical technique and analytical theory”

- December 14 – Francesco Corrao born in Palermo (Italy)  
 The first volume of the Spanish translation of Freud's works published, translated by López Ballesteros with a foreword by José Ortega y Gasset. Published in seventeen volumes between 1922 and 1932 (Spain)
- 1923
- March 4 – Freud's first letter to Romain Rolland: "I will keep until the end of my days the joyful memory of having been able to exchange a greeting with you. Since for us your name is associated with the most precious of all the beautiful illusions, the one of love expanding for all humanity." (France)
- April – Freud publishes *Das Ich und das Es* (*The Ego and the Id*, 1923b)
- April 20 – Freud's first operation by the oto-rhino-laryngologist Marcus Hajek, Schnitzler's brother-in-law: excision on the right side of the upper jaw of a leucoplast. Freud writes to Jones on the April 25: "I still have not begun working again, and I cannot swallow anything. They assured me the thing is benign, but as you know, nobody can guarantee the evolution when it will begin again to develop. Personally, I had diagnosed an epithelioma, but they didn't go along with me. Tobacco is the suspect in the etiolation of this tissue in rebellion."
- June 19 – Heinz Rudolf Halberstadt ("Heinerle" or "Heinele"), Sophie's second son, dies in Vienna at four and a half years old, from military tuberculosis. Freud writes to Ludwig Binswanger on October 15, 1926: "He was the favorite of my children and grandchildren, and since Heinele's death I can no longer stand my grandchildren, and I no longer have a taste for life. That's the secret of my indifference—what was called courage—facing my own risk of death."
- July 8 – Didier Anzieu born in Melun (France)
- August 2–7 – Angélo Hesnard presents the annual psychiatric report during the 17th Congress of Alienists and Neurologists of France and of French-language countries (Besançon): "Psychoanalysis. Etiological, methodological, therapeutic and psychiatric value of doctrine." In its conclusion he writes: "It is there that Psychoanalysis, relieved from its terminological errors, from its doctrinaire utterances, and from the symbolic artifice of semiological research, is connected with Psychiatry, of which it is tributary, and with clinical psychology (...) It is there that this doctrine-method, still awkward, but very perfectible, has its incontestable rights to our scientific and French sympathy." (France)
- August 26 – Meeting of the Secret Committee at the Castel Toblino, then at San Cristoforo, at the Lago Caldorazzo. This will be the last, due to the dissensions, particularly between Ernest Jones and Otto Rank, and the Committee will be dissolved in April 1924. This is likewise Freud's last stay in Italy
- October – Edoardo Weiss gives a conference on psychoanalysis at the Florence Congress of the Italian Society of Psychology (Italy)
- October 4 and 11 – Operations on Freud's tumor at the Auersperg Sanatorium. He is henceforth required to wear a prosthesis that makes eating and speaking painful for him
- October 22 – Maud (Magdalena) Mannoni-van der Spoel born in Courtrai (Belgium)

- October 25 – René Laforgue's first letter to Freud (France)
- November 19 – Piera Aulagnier-Spairani born in Milan (Italy)
- December – *Das Trauma der Geburt (The Trauma of Birth)* by Otto Rank published (Austria)
- Because of Freud's illness, Paul Federn will assume the vice-presidency of the Vienna Psychoanalytical Society from 1923 to 1938
- Buch vom Es. Psychoanalytische Briefe an eine Freundin* by Georg Groddeck published (Germany)
- The New York Psychoanalytic Society designates the first Educational Committee, in charge of organizing and improving its pedagogical activities (USA)
- 1924
- April 21–23 – 8th Congress of the International Psychoanalytical Association in Salzburg, for the first time in the absence of Freud (Austria). President: Karl Abraham
- April 27 – Otto Rank's departure for several months in America (USA)
- May 14 – Romain Rolland visits Freud in Vienna (France)
- July 6 – Serge Leclair (Liebschutz) born in Strasbourg (France)
- September 9 – Dr. Hermine Hug-Hellmuth is murdered by her eighteen-year-old nephew, Rudolph Hug, her sister's illegitimate child whom she took care of after her sister's death (Austria)
- 1925
- February 24 – The Viennese municipality, by decree, forbids Theodor Reik to practice psychoanalysis (Austria)
- April – First publication of the future review *L'Evolution psychiatrique, Psychanalyse—psychologie clinique* (Psychiatric Evolution, Psychoanalysis—Clinical Psychology) edited by Angélo Hesnard and René Laforgue (France)
- June 7 – Società Psicoanalitica Italiana (S.P.I.) founded by Marco Levi Bianchini. The journal *Archivio Generale di Neurologia, Psichiatria e Psicoanalisi* becomes its official mouthpiece (Italy)
- June 20 – Josef Breuer dies in Vienna (Austria)
- July – Melanie Klein is invited to London where she gives a series of six conferences in English on "*Frühanalyse*" (Great Britain)
- August 14 – The Narkompros (Ministry of Public Instruction) orders the closing of Detski Dom (Children's Home), founded and directed by Véra Schmidt (Russia)
- September 2–5 – 9th Congress of the International Psychoanalytical Association in Bad Homburg (Germany). President: Karl Abraham. Training Committee founded by Max Eitingon, who becomes president and states the rules of supervision
- September 30 – Freud begins the analysis of princess Marie Bonaparte; he writes of her to Sándor Ferenczi on October 18: "She not at all an aristocrat, rather *ein Mensch* and the work with her is going marvelously." (France)
- October – Rudolph M. Loewenstein settles in Paris as a didactician. He eventually becomes the analyst of Sacha Nacht, Jacques Lacan, and Daniel Lagache (France)

December 15 – Robert J. Stoller born in Crestwood, New York (USA)

December 25 – Karl Abraham dies in Berlin. Freud writes to Ernest Jones five days later: “Abraham’s death was without a doubt the biggest loss that could hit us, and it hit us. I called him, in jest, in certain letters ‘mon rocher de bronze.’ I felt reassured in the absolute trust he inspired in me as well as all the others. I applied to him the words of Horace: ‘Integer vitae scelerisque purus’ (The onewhose life has integrity and is without reproach). Max Eitingon succeeds him in the presidency of the IPA

Lehrinstitut der Wiener Psychoanalytischen Vereinigung (Training Institute of the Vienna Psychoanalytical Society) is created by the Vienna Psychoanalytical Society under the direction of Helene Deutsch, Anna Freud, and Siegfried Bernfeld. The committee consists of P. Federn, H. Nunberg, W. Reich, and E. Hitschmann (Austria)

The analytical cure is recognized by the new Prussian enactment on honorarium and the German general convention of physicians (Germany)

Adolf Josef Storfer succeeds Otto Rank as director of the Internationalen Psychoanalytischen Verlag. Max Eitingon, Sandor Rado, and Sándor Ferenczi replace Rank at the editorial desk of the *Internationale Zeitschrift für (ärztliche) Psychoanalyse*

Freud publishes *Selbstdarstellung* (An Autobiographical Study, 1925d [1924])

1926

January 21 – Freud publishes *Hemmung, Symptom und Angst* (Inhibitions, Symptoms and Anxiety, 1926d [1925])

March 24 – *Geheimnisse einer Seele* (Mysteries of a Soul), first film on psychoanalysis, produced by G. W. Pabst, presented in Berlin (Germany)

April 13 – Last meeting between Otto Rank and Freud, who writes to Sándor Ferenczi: “I found no motive to show a particular tenderness, at the time of his parting visit; I was frank and hard. But we don’t have to put a cross on him.”

April 24 – The Berliner Psychoanalytische Vereinigung becomes the Deutsche Psychoanalytische Gesellschaft (D.P.G.) (Germany)

August 1 – First Conference of Psychoanalysts in the French Language (Geneva), presided over by Raymond de Saussure (Geneva) with reports by René Laforgue (Paris) on “Schizophrenia and Schizonoia” and by Charles Odier (Geneva), “Contribution to the Study of Superego and Moral Phenomenon.” The creation of a Linguistic Commission is decided upon to unify French psychoanalytic vocabulary (Switzerland)

September – Freud publishes *Die Frage der Laienanalyse* (The Question of Lay Analysis, 1926e)

September – *Sigmund Freud*, a biography by Honorio Delgado, published (Peru)

September – Melanie Klein leaves Berlin for London (Great Britain)

September 22 – Sándor Ferenczi leaves for America for a six-month stay (USA)

September 28 – The Psychoanalytical Clinic founded in London with the donation of an ex-patient, Prynns Hopkins. Ernest Jones states: “The team includes a director, myself, an assistant director, Dr. Edward Glover, nine physicians, the Doctors Bryan, Cole, Eder, Herford, Inman, Payne, Rickman, Riggall and Stofddart, with five assistants” (Great Britain)

October – The Wolf Man begins analysis again with Ruth Mack Brunswick

November 4 – Société psychanalytique de Paris founded by Marie Bonaparte, Eugénie Sokolnicka, Angélo Hesnard, René Allendy, Adrien Borel, René Laforgue, Rudolph Loewenstein, Georges Parcheminey, and Edouard Pichon (France)

November 23 – A circular letter written by Anna Freud under her father’s dictation reestablishes the *Rundbriefe* (circular letters), and the Secret Committee acts henceforth as the “central management of the International Psychoanalytical Association”

November 28 – Freud is named Honorary Member of the Swiss Society of Psychiatry in place of Emil Kraepelin

*Zeitschrift für psychoanalytische Pädagogik* founded by Heinrich Meng (Germany) and Ernst Schneider (Switzerland)

*Almanach der Psychoanalyse* founded and published by the Internationaler Psychoanalytischer Verlag (International Psychoanalytical Publishers). Thirteen volumes appear before the Nazis liquidate the publishing house in 1938

1927

January 10 – Joseph Sandler born in Cape Town (South Africa)

April 10 – Schloss Tegel—Psychoanalytische Klinik Sanatorium (Tegel Castle—Psychoanalytical Clinic Sanatorium) founded by Ernst Simmel (Germany)

June 25 – Revue française de psychanalyse (French Review of Psychoanalysis) founded (France)

September – Tenth Congress of the International Psychoanalytical Association in Innsbruck (Austria). President: Max Eitingon

Sociedade Brasileira de Psicanálise founded in São Paulo by Durval B. Marcondes. President: Franco da Rocha. It will be recognized provisionally in 1929 by the International Psychoanalytical Association but without final establishment (Brazil)

Freud publishes *Die Zukunft einer Illusion* (*The Future of an Illusion*, 1927c)

The Burlingham-Rosenfeld/Hietzing Schule (Burlingham-Rosenfeld School or Hietzing School) founded in Vienna by Dorothy Burlingham and Eva Rosenfeld, a private school placed under Anna Freud’s care (Austria)

Melanie Klein becomes member of the British Psychoanalytical Society (Great Britain)

1928

September 30 – Ernst Simmel inaugurates the new premises of the Berliner Psychoanalytische Institut (BPI) (Berlin Psychoanalytical Institute), arranged under Ernst Freud’s direction (Germany)

October – Sándor Ferenczi gives conferences in Spain. He writes to Georg Groddeck on October 17: “Aside from

that, the doctors, here, are still half-Breuerians, already half-Jungians, without having ever been Freudians.” (Spain)

Tokyo Psychoanalytic Institute founded by Kenji Otsuki. It is recognized by the International Psychoanalytical Association in 1931 (Japan)

A subsidiary of the Sociedade Brasileira de Psicanálise de São Paulo founded in Rio by V. Rocha, Durval B. Marcondes, and Julio Pires Porto-Carrero (Brazil)

Schweizerische Ärtegesellschaft für psychoanalyse (Swiss Medical Association for Psychoanalysis) founded by Emil Oberholzer and Rudolf Brun. It is never recognized by the IPA and dissolves in 1938 (Switzerland)

1929

February 10 – Frankfurter Institut der “Südwestdeutsche Psychoanalytische Arbeitsgemeinschaft” (Frankfurt Institute of Psychoanalysis) founded by Karl Landauer, Frieda Fromm-Reichmann, and Heinrich Meng. It is tied to the Institut für Sozialforschung (Institute for Social Research) of Max Horkheimer and Theodor Adorno (Germany) and its role is to disseminate the ideas of psychoanalysis by didactic analyses and theoretical courses at the university without therapeutic training (Germany)

July 28–31 – Eleventh Congress of the International Psychoanalytical Association in Oxford (Great Britain). President: Max Eitingon. The New York Psychoanalytical Society, through the intervention of A. A. Brill, its president, agrees to welcome analysts who are not doctors (USA). La Sociedade Brasileira de Psicanálise de São Paulo is recognized provisionally (Brazil)

August – Freud writes *Das Unbehagen in der Kultur* (Civilization and Its Discontents, 1930a [1929]), which is published at the end of December but dated 1930

October 24 – The stock market crash in New York ruins Max Eitingon

December 25 – Sándor Ferenczi distances himself from Freud and writes to him: “Psychoanalysis practices too unilaterally the analysis of obsessional neurosis and the analysis of character, that is to say, the psychology of the ego, neglecting the organic-hysterical base of the analysis; the cause is the overestimation of fantasy—and the underestimation of traumatic reality in pathogenesis.”

The first translation in Japanese of Freud’s work published (Japan)

Lehrinstitut der Wiener Psychoanalytischen Vereinigung founded from a department for borderline and psychotic patients by Paul Schilder; Eduard Bibring succeeds its management after Schilder’s emigration to America (Austria)

Adolf J. Storfer founds the bi-monthly journal *Die Psychoanalytische Bewegung* at the International Psychoanalytical Publishers. It is published until December 1933 (Austria)

Franz Alexander emigrates from Germany and settles in Chicago (USA)

1930

May 9 – Otto Rank excluded from the list of honorary members of the American Psychoanalytical Association at the time of his business meeting during the 1st Inter-

national Congress of Mental Hygiene in Washington (May 5–10)

August 28 – Anna Freud accepts the Goethe Prize from the town of Frankfurt-am-Main for her father (Germany)

September 12 – Freud's mother, Amalia (Malka) Freud, née Nathanson, dies in Vienna, at the age of ninety-five

Washington-Baltimore Psychoanalytic Society founded. It is comprised of, among other members, Ernest E. Hadley, Adolf Meyer, Harry Stack Sullivan, Clara Thompson, and William A. White, and is accepted as Constituent Society by the American Psychoanalytic Association

Psychoanalytical Institute founded in The Hague (Netherlands)

*The Psychopathology of Everyday Life* translated into Japanese by Kiyoyasu Marui

1931

August 22 – A Study Circle, which will become the Nordisk Psykoanalytisk Samfund (Nordic Psychoanalytical Society) founded in 1933 at the initiative of the Dane Sigurd Naesgaard, the Norwegian Harald Schjelderup, the Finn Vriö Kulovesi, and the Swede Alfhild Tamm

September 24 – The New York Psychoanalytic Institute, the first on the American continent, founded with the support of Abram A. Brill. Sándor Radó, who just emigrated, becomes the director

October 25 – A commemorative plaque is placed on Freud's birthplace at Pribor-Freiberg at the initiative of Dr. Emmanuel Windholz, Jaroslav Stuchlik, and Nicolai Ossipow

November – Angel Garma, after her training in Berlin, settles in Madrid until 1936

December – Henri Claude creates the post Head of Laboratory of Psychotherapy and Psychoanalysis at the Clinic of Mental Illnesses at the Paris Faculty of Medicine. Sacha Nacht holds the post

December 18 – Official opening of the Budapest Psychoanalytical Polyclinic, 12 Mészáros Street, founded with the support of Frédéric and Vilma Kovács. It will be directed by Sándor Ferenczi with Michael Balint as his assistant who will succeed him in 1933

Richard F. Sterba, at the suggestion of Adolf J. Storfer, undertakes the publication of the first dictionary of psychoanalysis (*Handwörterbuch der Psychoanalyse*) of which the first installment will be published on May 6, 1936, for Freud's eightieth birthday

First translation in Brazil of a Freud work, *Five Lectures*, by Durval B. Marcondes and J. Barbosa Correia

Edoardo Weiss publishes *Elementi di psicoanalisi* in Milan (Italy) with a preface by Sigmund Freud

Wilhelm Reich founds the German Association for a Sexual Proletarian Policy (Sex-Pol)

Martin Freud succeeds Adolf J. Storfer as commercial director of the Internationaler Psychoanalytischer Verlag

1932

June – The *Psychoanalytic Quarterly* founded by Dorian Feigenbaum, Bertram D. Lewin, Johns Hopkins, and Gregory Zilboorg, all members of the American Psychoanalytic Association and the New York Psychoanalytic Society

September 4–7 – Twelfth Congress of the International Psychoanalytical Association in Wiesbaden (Germany)

President: Max Eitingon. Affiliation of the Tokyo Psychoanalytical Institute and of the Chicago and Washington-Baltimore Societies. Ernest Jones is elected president of the IPA, Johan H.W. van Ophuijsen and Anna Freud remain vice-presidents, A.A. Brill is named third vice-president. Sándor Ferenczi presents his lecture "The Confusion of Tongues between Adults and the Child. The Language of Tenderness and of Passion"

September 7 – Date of the medical thesis presented by Jacques Lacan *De la psychose paranoïaque dans ses rapports à la personnalité* (Of paranoid psychosis in its relationship to personality) (France)

October 1 – Società Psicoanalitica Italiana (SPI) founded in Rome by Edoardo Weiss, Nicola Perrotti, and Emilio Servadio. Marco Levi Bianchini becomes honorary president. It is recognized by the IPA in 1935. The first issue of the *Rivista italiana di psicoanalisi* is published in April 1935, and immediately forbidden by the fascist regime. The Society is dissolved in 1938

Chicago Institute of Psychoanalysis founded by Franz Alexander, who remains president until 1952. Karen Horney, recently emigrated from Berlin, becomes the associate director

*Die Psycho-Analyse des Kindes (The Psycho-Analysis of Children)* by Melanie Klein published

Heisaku Kosawa (Japan) visits Freud and presents an account of his theory of the Ajase Complex

American Psychoanalytic Association is reorganized into a federation of associations. A "Council on Professional Training" created (USA)

Publication of the first *Czech Directory of Psychoanalysis*, under the direction of E. Windholz (Czechoslovakia)

*Verwahrloste Jugend (Wayward Youth)* by August Aichhorn published (Austria)

1933

January 30 – Adolf Hitler is elected chancellor of the Reich (Germany)

April 8 – Francisco Franco da Rocha dies in Amparo, State of São Paulo (Brazil)

May 10 – Freud's books are burned in Berlin

May 22 – Sándor Ferenczi dies in Budapest (Hungary)

June 21 – Carl G. Jung becomes president of the Allgemeine Ärztliche Gesellschaft für Psychotherapie (AAGP) after Ernst Kretschmer's resignation (Germany)

November 18 – Felix Boehm and Carl Müller-Braunschweig take the presidency of the Berlin Psychoanalytical Society, Max Eitingon having been dismissed as a Jew (Germany)

December – Psykoanalytisk Samfund founded, with the Swede Poul Bjerre, the Dane Sigurd Naesgaard, and the Norwegian Irgens Stromme (Denmark)

December 31 – Max Eitingon leaves Berlin for Jerusalem, where he founds the Palestine Psychoanalytical Society with Mosche Wulff (emigrated from Berlin the same year), Ilja Schalit, Anna Smelianski, Gershon and Gerda Barag, Vicky Ben-Tal, Ruth Jaffe, etc. (Israel)

The Prague Psychoanalytical Study Group founded and directed by Frances Deri until 1935, the year of his emigration to Los Angeles. Otto Fenichel succeeds him until 1938 (Czechoslovakia)



- Johan H.W. van Ophuijsen resigns from the Netherlands Psychoanalytical Society (NVP) to found the Netherlands Society of Psychoanalysts (VPN) with Van Emden and Maurits Katan (Netherlands)
- Freud publishes *Neue Folge der Vorlesungen zur Einführung in die Psychoanalyse* (*New Introductory Lectures on Psycho-Analysis*, 1933a [1932])
- Charakteranalyse* (*Character Analysis*) and *Die Massenpsychologie des Faschismus* (*The Mass Psychology of Fascism*) by Wilhelm Reich published (Austria)
- Life and Works of Edgar Poe: A Psycho-Analytical Study* by Marie Bonaparte published
- 1934
- January 10 – Institute of Psychoanalysis inaugurated in Paris. Director: Marie Bonaparte (France)
- February 19 – Nikolai Ossipov dies in Prague (Czech Republic)
- May 19 – Eugenia Sokolnicka-Kutner commits suicide in Paris (France)
- June 11 – Georg Groddeck dies in Knonau bei Zürich (Switzerland)
- August 26–31 – Thirteenth Congress of the International Psychoanalytical Association in Lucerne (Switzerland). President: Ernest Jones. Wilhelm Reich is expelled from the International Psychoanalytical Association. A Dano-Norwegian association and a Finn-Swedish association Svensk-Finska Psykoanalytiksla Foereningen (Otto Fenichel, Ludwig Jekels) are created
- 1935
- May 15 – Freud is named Honorary Member of the Royal Society of Medicine of London (Great Britain)
- October 24 – Edith Jacobsohn, militant in the socialist resistance group *Neu Beginnen* (New Beginnings) is arrested and imprisoned (Germany)
- December 1 – Meeting of the Berlin Psychoanalytic Society, under Ernest Jones's presidency. The Jewish members leave "voluntarily" (*freiwillig Rücktritt*) (Germany)
- 1936
- March 28 – The Internationaler Psychoanalytischer Verlag repository in Leipzig is sequestered by the Nazis (Germany)
- April – A psychoanalytical polyclinic founded in Paris by John Leuba and Michel Cénac (France)
- May – Deutsches Institut für Psychologische Forschung und Psychotherapie (1936–1945) founded under the direction of Matthias Heinrich Göring. Felix Boehm is named dean (Germany)
- May 5 – Ernest Jones inaugurates the new home of the Vienna Psychoanalytical Association, 7 Berggasse, designated for Association meetings, the Viennese Psychoanalytical Institute, consultation, and a library
- May 6 – Celebration of Freud's eightieth birthday
- June 30 – Freud is named "Foreign Member, Royal Society" of Great Britain, a supreme scientific honor in England (Great Britain)
- July – Beginning of the civil war in Spain (1936–1939), followed by Franco's dictatorship
- August 2–8 – Fourteenth Congress of the International Psychoanalytical Association in Marienbad (Czechoslo-

- vakia). President: Ernest Jones. The Czech Study Group is officially recognized. The American Psychoanalytical Association obtains exclusive power over its composition in North America (exclusion of non-doctors)  
 Anna Freud publishes *Das Ich und die Abwehrmechanismen* (*The Ego and the Mechanisms of Defense*)
- 1937
- January – Marie Bonaparte acquires the correspondence between Sigmund Freud and Wilhelm Fliess
- February 5 – Lou Andreas-Salomé dies in his house “Loufried” in Göttingen (Germany)
- May 30 – Alfred Adler dies in Aberdeen, Scotland (Great Britain)
- July 27 – The Russian Psychoanalytic Society halts its activities. Twenty years of silence on psychoanalysis will follow in Russia
- December 30 – Julio Pires Porto-Carrero dies in Rio de Janeiro (Brazil)
- Philadelphia Psychoanalytic Society founded (USA)
- Adelheid L. Koch, recent émigrée from Germany endorsed by Ernest Jones and Otto Fenichel (her analyst), begins the didactic analyses of Durval Marcondes, Darcy Mendonça Uchôa, Virginia Bicudo, Flavio Dias, Frank Philips, etc., in São Paulo (Brazil)
- Freud publishes “Die endliche und die unendliche Analyse” (“Analysis Terminable and Interminable”, 1937c)
- 1938
- March 10 – The German Army invades Austria. On March 12, Vienna is occupied and Hitler arrives on the 14th. March 15, the “Anschluss,” the connecting of Austria to Germany, is proclaimed
- March 20 – Vienna Psychoanalytic Society dissolved in the presence of Sigmund Freud; the commissioner appointed by the NSDAP (National Socialist [Nazi] Party), Dr. Anton Sauerwald; Ernest Jones, President of the International Psychoanalytical Association; Marie, Princess of Greece, Vice-President of the International Psychoanalytical Association; Anna Freud, Vice-President of the International Psychoanalytical Association and Vice-President of the Viennese Psychoanalytical Society; Carl Müller-Braunschweig, Secretary of the German Society of Psychoanalysis and administrative council member of the German Institute of Psychological Research and Psychotherapy in Berlin; Paul Federn, Vice-President of the Viennese Psychoanalytical Society, Eduard Hitschmann, Edward Bibring, Heinz Hartmann, Ernst Kris, Robert Waelder, Willi Hoffer, B. Steiner, members of the board of directors; and Martin J. Freud, of the Internationaler Psychoanalytischer Verlag. The Society will be officially liquidated under an ordinance of the Magistrate of the city of Vienna, September 1, 1938
- March 22 – Freud notes in his journal: “Anna bei Gestapo” (“Anna with Gestapo”)
- May – Hanns Sachs founds *American Imago* in Boston, Massachusetts. The first issue will be published in November 1939 (USA)
- May 29 – Bruno Bettelheim is arrested by the Gestapo. He spends ten and a half months in Dachau then in Buchenwald, where meets Ernst Federn again (Austria)
- June 4 – Freud leaves Vienna on June 4 with Martha, Anna, Paula Fischl, and Dr. Josephine Stross. Arriving in

- Paris the next day, he stays with Marie Bonaparte before leaving for London, where he arrives on June 6
- June 23 – Three secretaries of the Royal Society (Sir Albert Steward, A. V. Hill, Griffith Davies) bring Freud the Charter Book to sign (Great Britain)
- June 23 – Freud receives Stefan Zweig, who presents to him Salvador Dali. Freud remarks on Dali’s “candid and fanatical eyes and his undeniable technical mastery”
- August 1–5 – Fifteenth Congress of the International Psychoanalytical Association in Paris (France). President: Ernest Jones. The American Psychoanalytic Association appeals and assumes the right, on account of the war and citing the “1938 rule,” to total autonomy concerning standards in the United States, in excluding non-doctors, with the exception of those who had trained before 1938
- September 27 – Freud and Anna move to 20 Maresfield Gardens, which Martha and Paula Fischl fix up in two days
- November 19 – The Deutsche Psychoanalytische Gesellschaft (D.P.G.) is dissolved and carries on as Arbeitsgruppe A (Work Group A) within the Deutsches Institut für psychologische Forschung und Psychotherapie (Germany)
- 1939
- March 10 – *Der Mann Moses und die monotheistische Religion: Drei Abhandlungen (Moses and Monotheism: Three Essays, 1939a [1934–38])* published in Amsterdam
- September 1 – Hitler invades Poland. Beginning of the Second World War
- September 23 – Sigmund Freud dies before midnight after morphine injections given at his request by his doctor Max Schur, after a day and a half in a coma. He is cremated on the September 26 at the Golder’s Green Crematorium
- October 31 – Otto Rank (Rosenfeld) dies in New York (USA)
- Franz Alexander publishes the journal *Psychosomatic Medicine*, with Flanders Dunbar, Stanley Cobb, Carl Binger, and others (USA)
- Philadelphia Association for Psychoanalysis founded (USA)
- Ichpsychologie und Anpassungsproblem (Ego Psychology and the Problem of Adaptation)* by Heinz Hartmann published (Germany)
- 1940
- June 25 – Wilhelm Stekel commits suicide in London (Great Britain)
- September 31 – Edouard Claparède dies in Geneva (Switzerland)
- October 10 – Melbourne Institute for Psychoanalysis founded (Australia), inaugurated by Judge Foster at 111 Collins Street. Due to the generosity of Miss Lorna Traill, the first meeting takes place at the home of Hal Maudsley, a prominent figure in Australian psychiatry
- The Detroit Psychoanalytic Society founded by Richard F. Sterba with Leo H. Bartemeier and Klara Happel-Pinkus. Sterba is president from 1946 to 1952 (USA)

- Carl G. Jung retires from the Allgemeine Ärztliche Gesellschaft für Psychotherapie (AAGP) (Germany)  
*Psicoanalisis de los sueños (Psychoanalysis of Dreams)* by Angel Garma published (Argentina)  
*Abriss der psychoanalyse* ("An Outline of Psychoanalysis," 1940a [1938]) by Sigmund Freud published
- 1941
- February 13 – Minna Bernays dies in London (Great Britain)
- April 2 – Karen Horney is excluded from the didacticians of the New York Psychoanalytic Society. She will found the Association for Advancement of Psychoanalysis, accompanied by Clara M. Thompson, Harry Stack Sullivan, and Erich Fromm. She will also organize the American Institute for Psychoanalysis, where she will be Dean until her death in 1952
- December 7 – Attack on Pearl Harbor by Japanese aircraft
- Abram Kardiner leaves the New York Psychoanalytic Institute (USA)
- 1942
- February 22 – Stefan Zweig commits suicide in Petropolis (Brazil)
- July 12 – René Allendy dies in Montpellier (France)
- December 15 – Asociacion Psicoanalitica de Argentina (APA) founded by Angel Garma, who becomes the first president, with Celes Ernesto Càrcamo, Guillermo Ferrari Hardoy, Marie Glas de Langer, Enrique Pichon-Rivière, and Arnaldo Rascovsky
- San Francisco Psychoanalytic Society founded by Otto Fenichel and others (USA)
- Freud's sisters Marie (Mitzi), Pauline (Pauli), and Rosa killed in deportation
- Topeka Institute for Psychoanalysis founded by Karl Menninger in the hospice of the Menninger Clinic (USA)
- 1943
- January 27 – Susan Isaacs presents her writing on the "Nature and Function of Fantasy," first contribution to *Controversial Discussions* that oppose the students of Anna Freud and Melanie Klein before an ad hoc commission of the British Psycho-Analytical Society until 1944 (Great Britain)
- February 2 – The German Army surrenders in Stalingrad (USSR)
- February 5 – Adolfine (Dolfi) Freud killed by the Nazis in the Treblinka concentration camp
- May 13 – John Rittmeister is guillotined by the Nazis in Berlin-Plötzensee (Germany)
- July 3 – Max Eitingon dies in Jerusalem (Israel)
- Psychoanalytical Institute of the Asociacion Psicoanalitica de Argentina (APA), the *Revista de Psicoanálisis* (Arnaldo Rascovsky is the first editor-in-chief), and the Biblioteca de Psicoanálisis founded (Argentina)
- The Palestine Psychoanalytic Society, founded in 1933, is recognized by the IPA (Israel)
- William Alanson White Institute, the New York branch of the Washington School of Psychiatry, founded by Harry Stack Sullivan, Clara Thompson, Frieda Fromm-Reichman, and Eric Fromm, who leave Karen Horney (USA)

- Publication of the *New German-English Psychoanalytical Vocabulary*, by Alix Strachey-Sargant, and of the first volume of the *Standard Edition of the Complete Psychological Works of Sigmund Freud (SE)*. Twenty-four volumes are published between 1943 and 1974 (Great Britain)
- Finno-Swedish Psychoanalytic Society dissolved after the death of Yrjö Kulovesi (Finland–Sweden)
- Az ember ősi ösztönei Pantheon* (The Filial Instinct) by Imre Hermann published (Hungary)
- 1944
- June 6 – Landing of Allied troops in Normandy (D-Day) (France)
- August 25 – Liberation of Paris (France)
- December 30 – Romain Rolland dies in Vézelay (France)
- Adelheid L. Koch founds the Grupo Psicanalítico de São Paulo, and young psychiatrists in Rio found the Centro de Estudos Juliano Moreira (Brazil)
- Sándor Radó is dismissed as Education Director then stripped from the list of didacticians at the New York Psychoanalytic Institute
- Bruno Bettelheim is named director of the Orthogenic School at the University of Chicago (USA)
- The Psychology of Women. A Psychoanalytic Interpretation* by Helene Deutsch published. The second volume appears in 1945
- 1945
- January 15 – The Psychoanalytic Clinic for Training and Research in the Department of Psychiatry at Columbia University, College of Physicians and Surgeons, founded by Sándor Radó, who becomes director, with Abram Kardiner, George Daniels, and David Levy. This Clinic is the first psychoanalytic institution affiliated with the American Psychoanalytic Association to be created in a university and medical school(USA)
- January 27 – Karl Landauer dies in the Bergen-Belsen concentration camp (Germany)
- April 30 – Adolf Hitler's suicide, after Benito Mussolini's execution on April 24
- May 4 – Harald Schultz-Hencke (with Werner Kemper) founds and becomes the director of the Institut für Psychopathologie und Psychotherapie (IPP), to teach "neoanalysis," as opposed to classic psychoanalysis (Germany)
- May 8 – Allied victory proclaimed, ending the Second World War in Europe
- August 6 – The first American atomic bomb is dropped on Hiroshima (Japan)
- October – The Grupo Psicanalítico de São Paulo is accepted provisionally as Sociedade Brasileira de Psicanálise de São Paulo (SBPSP) by Ernest Jones (Brazil)
- October 19 – The Deutsche Psychoanalytische Gesellschaft (DPG) is recreated (as the Berliner Psychoanalytische Gesellschaft until December 3, 1950) with Carl Müller-Braunschweig as the first president; Felix Boehm, his deputy; and Werner Kemper as third member of the bureau (Germany)
- November – The Neederlandsche Vereeniging voor Psychoanalyse (Netherlands Society for Psychoanalysis) is

- recreated. The Amsterdam Institute of Psychoanalysis is founded in 1946 (Netherlands)
- December 1 – The dissolution of the Viennese Psychoanalytical Society is appealed in 1938
- The review *The Psychoanalytic Study of the Child* (USA) created by Anna Freud, Heinz Hartmann, and Ernst Kris (USA)
- The Psychoanalytic Theory of Neurosis* by Otto Fenichel published (USA)
- 1946
- February 16 – A provisional executive committee established for the re-creation of the Wiener Psychoanalytische Vereinigung (Vienna Psychoanalytical Society). President: August Aichhorn (Austria)
- April 15 – The Sigmund Freud Copyrights Limited is established by Freud's beneficiary executors, Ernst, Martin, and Anna, in order to collect the rights and to distribute them to Freud's grandchildren (Great Britain)
- May 14 – First issue of the journal *Psyché, Revue internationale de Psychanalyse et des Sciences de l'Homme* (Psyche, International Review of Psychoanalysis and the Sciences of Man), created by Maryse Choisy. It is published until 1963 (France)
- July 22 – Otto Fenichel dies in Los Angeles (USA)
- July 25 – First post-war congress of French language psychoanalysts, in Montreux (Switzerland)
- December 24 – Maurice Dugautiez and Fernand Lechat found the Belgian Association of Psychoanalysts under the patronage of the Paris Society. It will be recognized by the IPA in 1947 (Belgium)
- The Indian Psychoanalytic Society publishes a journal entitled *Samiksa* (India)
- The Los Angeles Institute for Psychoanalysis founded (USA)
- Montreal Psychoanalytic Club (or Cercle psychanalytique de Montréal) founded by Miguel Prados (Canada)
- Ernest Jones resigns from his post at the British Psychoanalytical Society (Great Britain)
- The Psychopathology and Psychotherapy Society founded by Ion Popesco-Sibiu and Doctor Constantin Vlad (Romania)
- The Society for the Study of Psychoanalysis is recreated by Theodor Dosuzkov, but it will be forced to dissolve in 1950 (Czech Republic)
- The Società Psicoanalitica Italiana (SPI) is recreated by Nicola Perrotti, Emilio Servadio, Cesare Musatti, and Alessandra Tomasi di Palma di Lampedusa-Wolf Stomersee. The first National Congress of Psychoanalysis is organized in Rome (Italy)
- The American Psychoanalytic Association reorganized into a "Board on Professional Standards," responsible for all the affairs of analytical training, and an "Executive Council," responsible for membership and practical problems (USA)
- 1947
- January 10 – Hanns Sachs dies in Boston (USA)
- May 9 – Institut für Psychotherapie founded in Berlin by Felix Boehm (Germany)
- November 11 – Ernst Simmel dies in Los Angeles (USA)

The journal *Psyche. Jahrbuch für Tiefenpsychologie und Menschenkunde in Forschung und Praxis* (Annals for Depth Psychology and Human Sciences, Research and Practice) founded by Alexander Mitscherlich, Hans Kunz, and Felix Schottlaender (Germany)

Instituto Brasileiro de Psicanálise (IBP) founded in Rio de Janeiro to accommodate the arrival of foreign analysts (Brazil)

The first Greek psychoanalytical group, centered around the princess Bonaparte, founded by Andreas Embirikos and Demetrios Kouretas (Greece)

The Norwegian-Danish society recreated by Harald Schjelderup, Trygve Braatøy, and Hjørdis Simonsen. It remains active until 1953 (Norway–Denmark)

The Dutch Association of Psychoanalysis founded by Westerman Holstijn and Van der Hoop (Netherlands)

Anna Freud and her collaborators and the British Psychoanalytic Society reach a common agreement that the *International Journal of Psychoanalysis* is the official mouthpiece of the IPA, but the British Psychoanalytic Society remains the guardian of the journal and it continues to be published by a British editor

Wiener Arbeitskreis für Tiefenpsychologie (Viennese Work Circle for Depth Psychology) founded by Igor Caruso (Austria)

1948

March 2 – Abraham Arden Brill dies in New York (USA)

October 12 – Susan Isaacs-Sutherland dies in London (Great Britain)

December – Arriving in Rio de Janeiro, Werner Kemper, analyzed by Carl Müller-Braunschweig, supervised by Felix Boehm, Otto Fenichel, Jenö Hárnik, and Ernst Simmel, comes to complete the instructional work undertaken by Mark Burke, who arrived on February 2 (Brazil)

The Deutsche Gesellschaft für Psychoanalyse, Psychotherapie, Psychosomatik und Tiefenpsychologie, an organization covering all the tendencies of depth psychology (Jungians and Adlerians), founded by W. Bitter (Germany)

The *Revue Française de Psychanalyse* (French Review of Psychoanalysis) begins publication again at the Presses Universitaires de France (France)

Palestine Psychoanalytic Society becomes the Israel Psychoanalytic Society (Israel)

The National Psychological Association for Psychoanalysis (NPAP) is founded by Theodor Reik. It becomes official in 1950 (USA)

The journal *Psiche* founded by Nicola Perrotti (Italy)

1949

July 15–17 – Sixteenth Congress of the International Psychoanalytical Association, first post-war congress, in Zurich (Switzerland). President: Ernest Jones, succeeded by Leo Bartemeier: the beginning of alternating presidents from Europe and North America. Affiliation of the Argentine Psychoanalytical Association (APA) and the Chilean Association of Psychoanalysis. A provisional admission for the Deutsche Psychoanalytische Gesellschaft (DPG) to the IPA is decided. To this date, twelve societies are affiliated with the American Psychoanalytic Association (APA): New York, Washington-Baltimore, Chicago, Boston, Philadelphia-Society, Topeka,

- Detroit, San Francisco, Columbia University, Los Angeles, Baltimore, and Philadelphia-Association.  
 October 13 – August Aichhorn dies in Vienna (Austria)  
*The Basic Neurosis. Oral Regression and Psychic Masochism* by Edmund Bergler published (USA)  
*Trattato di psicoanalisi* by Cesare Musatti published (Italy)
- 1950
- May 4 – Paul Federn, diagnosed with cancer, commits suicide in New York  
 May 31 – Johan H.W. van Ophuijsen dies in Detroit (USA)  
 June 10 – The Deutsche Psychoanalytische Vereinigung (D.P.V.) founded by Carl Müller-Braunschweig, followed by the creation of the Karl Abraham Institut (Germany)  
 The Society for Psychoanalytic Medicine of Southern California founded with Franz Alexander, Samuel Eisenstein, Martin Grotjahn, etc.  
 First World Conference in Psychiatry in Paris organized by Henri Ey, with the participation of Anna Freud and Melanie Klein  
*The British Journal of Delinquency* (later *The British Journal of Criminology*) founded by Edward Glover (Great Britain)  
*Sigmund Freud, Aus den Anfängen der Psychoanalyse, Briefe an Wilhelm Fließ, Abhandlungen und Notizen aus den Jahren 1887–1902*, edited by M. Bonaparte, A. Freud, and E. Kris, published in London by Imago (1950a [1887–1902])  
*Childhood and Society* by Erik H. Erikson published (USA)  
*Neurosis and Human Growth: The Struggle toward Self-Realization* by Karen Horney published (USA)
- 1951
- August – 17th Congress of the International Psychoanalytical Association in Amsterdam (Netherlands). President: Leo Bartemeier. Definitive acceptance of the Sociedade Brasileira de Psicanálise de São Paulo (SBPSP) (Brazil) and the Deutsche Psychoanalytische Vereinigung (D.P.V.) (Germany). Heinz Hartmann is elected president  
 November 2 – Martha Freud-Bernays dies  
 December 4 – Beginning of the Mrs. Clark-Williams trial in Paris; she is accused of the illegal practice of medicine, is acquitted March 31, 1952, but is found guilty in an appeal in June 1953 in the “franc symbolique” (France)  
 The Western New England Psychoanalytic Society founded (USA)  
 The Rio de Janeiro Society of Psychoanalysis founded by Alcyon Baer Bahia, Danilo Perestrello, Marialzira Perestrello, and Walderedo Ismael de Oliveira, called the “Argentines.” It is not recognized by the IPA (Brazil)  
 The Hampstead Child Therapy Clinic (21 Maresfield Gardens, London) founded by Anna Freud in collaboration with Helene Ross and Dorothy Burlingham (Great Britain)  
 Sydney Institute of Psychoanalysis founded by Roy Coupland Winn with Andrew Peto, originally from Hungary (Australia)



- Maternal Care and Mental Health* by John Bowlby published (Great Britain)
- 1952
- June 17 – The Institut de Psychanalyse de Paris (Paris Institute of Psychoanalysis) founded under the direction of Sacha Nacht
- December 4 – Karen Horney-Danielsen dies in New York (USA)
- Kurt Eissler creates the Anna Freud Foundation to profit the Hampstead Child Therapy Course and the Hampstead Clinic (USA)
- Psychoanalysis*, the first journal representing an institution of non-medical training, founded by the National Psychological Association for Psychoanalysis (NPAP). Theodor Reik is the editor-in-chief (USA)
- The Instituto di Psicoanalisi di Roma founded by Nicola Perrotti (Italy)
- The Sigmund Freud Archives, a depository in the Library of Congress, founded in Washington, DC; Kurt Eissler becomes director (USA)
- Ego Psychology and the Psychoses* by Paul Federn published (USA)
- 1953
- April 2 – Siegfried Bernfeld dies in San Francisco (USA)
- April 15 – Pope Pius XII gives an address through which the Church recognizes the validity of psychotherapy and psychoanalysis (Rome)
- June 7 – Géza Róheim dies in New York (USA)
- June 16 – Juliette Favez-Boutonier, Françoise Dolto, and Daniel Lagache, followed by Jacques Lacan, resign from the Paris Psychoanalytical Society and announce the creation of the French Society of Psychoanalysis, Study and Freudian Research Group (France)
- July 26 – 18th Congress of the International Psychoanalytical Association in London. President: Heinz Hartmann. A committee is formed by Kurt Eissler, Phyllis Greenacre, Hedwig Hoffer, Jeanne Lampl-de-Groot and Donald Winnicott to judge the application for admission requested by the French Society of Psychoanalysis (France). The Norwegian Society's application is rejected in part because of the didactic practice of Harald Schjelderup (Norway). The Danish Society of Psychoanalysis obtains the status of Work Group (Denmark). Werner Kemper's Centro de Estudos Psicanalíticos is recognized as Study Group under the sponsorship of the São Paulo Society (Brazil)
- September 26–27 – Following the 16th Conference of Romance Language Psychoanalysts, Jacques Lacan gives his "Rome Report": "Function and Range of Speech and Language in Psychoanalysis" (France)
- October 17 – The Canadian Society of Psychoanalysts/Société des psychanalystes canadiens is dissolved and replaced by the Société canadienne de psychanalyse/Canadian Psychoanalytic Society (Canada)
- The New Orleans Psychoanalytic Society founded (USA)
- Publication of the first volume of *Life and Work of Sigmund Freud* that Ernest Jones will publish in three volumes from 1953 to 1957, in London, at Hogarth Press

*JAPA, Journal of the American Psychoanalytic Association*, official mouthpiece of the American Psychoanalytic Association, founded. John Frosch is the editor-in-chief for twenty years, assisted by Nathaniel Ross (USA)

1954

June 1 – Official inauguration of the Institute of Psychoanalysis of the Paris Psychoanalytical Society and creation of a Center for Consultation and Psychiatric Treatment (France)

First International Congress of Psychotherapy of the Group in Toronto (Canada)

1955

May 6 – Henri Flournoy dies in Geneva (Switzerland)

July 26 – Nineteenth Congress of the International Psychoanalytical Association in Geneva (Switzerland). President: Heinz Hartmann. The French Society of Psychoanalysis is not recognized as a society belonging to the IPA (France). Affiliation of the Sociedade Psicanalítica do Rio de Janeiro (SPRJ), founded by Werner Kemper, Katrin Kemper, Fabio Leite Lobo, Gerson Borsoi, Inaura Carneiro Leão Vetter, Luiz Guimarães Dahlheim, and Noemy Rudolfer (Brazil)

September 27 – Under the influence of Willy Baranger, the Asociación Psicoanalítica del Uruguay is founded

The Psychoanalytic Association of New York and the Michigan Psychoanalytic Association founded (USA)

Cesare Musatti founds the *Revista di psicoanalisi*, official mouthpiece of the Società Psicoanalitica Italiana (SPI) (Italy)

Heisaku Kosawa founds the Psychoanalytical Society of Japan

The Washington Psychoanalytic Institute is accredited by the American Psychoanalytic Association (USA)

The Association Internationale de Psychologie Analytique (International Association of Analytical Psychology) (AIPA) founded

*The Technique of Psycho-Analysis* by Edward Glover published (Great Britain)

1956

May 6 – For the hundredth anniversary of Freud's birth, Ernest Jones unveils a commemorative plaque on Freud's Maresfield Gardens house, Hampstead (Great Britain). In Paris, a plaque is placed at the Salpêtrière and on the façade of the little Latin Quarter hotel, rue Le Goff, where Freud lived in 1885–1886 (France)

May 6 – The Colombian Psychoanalytical Study Group founded, with Arnaldo Rascovsky (Colombia)

August 6 – Oskar Pfister dies in Zurich (Switzerland)

The Western New York Psychoanalytic Society founded (USA)

First issue of *La Psychanalyse*, review of the French Society of Psychoanalysis (France)

American Academy of Psychoanalysis founded by Franz Alexander, R. Orinker, and Frieda Fromm-Reichmann. Its first president is Janet Rioch Bard (USA)

First Latin-American Congress of Psychoanalysis in Buenos Aires (Argentina)

Toronto Psychoanalytic Study Circle founded by Alan Parkin (Canada)

- Primary Love and Psycho-Analytic Technique* by Michael Balint published (Great Britain)
- 1957
- February 27 – Ernst Kris dies in New York (USA)
- April 28 – Frieda Fromm-Reichmann dies in Rockville, Maryland (USA)
- July 28–31 – 20th Congress of the International Psychoanalytical Association in Paris (France). President: Heinz Hartmann. Affiliation of the Canadian Psychoanalytic Society (CPS), the Dansk Psykoanalytisk Selskat (DPS), and the Asociación Psicoanalítica Mexicana (A.P.M.). Recognized as Study Group: the Luso-Iberian Psychoanalytical Society, patronized by the Swiss Society of Psychoanalysis (SSP) and the Paris Psychoanalytical Society (SPP), the Study Group of the Asociación Psicoanalítica del Uruguay and the Colombian Psychoanalytical Study Group. William H. Gillespie is elected president of the IPA
- November 3 – Wilhelm Reich dies in the Lewisburg penitentiary, Connecticut (USA)
- The Cleveland Psychoanalytic Society and the Seattle Psychoanalytic Society founded (USA)
- First Latin-American congress of psychotherapy of the Buenos Aires group (Argentina)
- Sydney Institute of Psychoanalysis founded (Australia)
- A Research Committee founded by the British Psycho-Analytical Society (Great Britain)
- Envy and Gratitude* by Melanie Klein published (Great Britain)
- 1958
- February 11 – Ernest Jones dies in London (Great Britain)
- May 4 – Emil Oberholzer dies in New York (USA)
- September 20 – Felix Boehm dies in Berlin (Germany)
- October 12 – Carl Müller-Braunschweig dies in Berlin (Germany)
- December 20 – Clara M. Thompson dies in New York (USA)
- The “Groupe Lyonnais de Psychanalyse” founded around Charles-Henri Nodet within the Paris Psychoanalytical Society (France)
- The Association of Mental Health of the 13th arrondissement in Paris founded by Philippe Paumelle, Serge Lebovici, and René Diatkine (France)
- Institute for Psychoanalytic Training and Research founded (IPTAR) (USA)
- 1959
- January 11 – Edward Bibring dies in Boston (USA)
- July 26–30 – 21st Congress of the International Psychoanalytical Association in Copenhagen (Denmark). President: William H. Gillespie. Affiliation of the Sociedade Brasileira de Psicanálise de Rio de Janeiro (SBPRJ) (Brazil) and the Sociedad Luso-española de Psicoanálisis (Spain–Portugal)
- The Pittsburgh Psychoanalytic Society and the New Jersey Psychoanalytic Society founded (USA)
- New York Freudian Society (NYFS) founded under the name of New York Society of Freudian Psychologists (its name is changed because of provisions in the law of con-

- firmation in the State of New York concerning psychology) (USA)
- 1960
- April 27 – Official inauguration of the Institut und Ausbildungszentrum für Psychoanalyse und Psychosomatische Medizin (Institute and Training Center for Psychoanalysis and Psychosomatic Medicine) in Frankfurt-am-Main (Germany)
- May 5 – Maurice Bouvet dies in Paris (France)
- September – The French Society of Psychoanalysis (France) organizes its first international colloquium on female sexuality in Amsterdam (Netherlands)
- September 22 – Melanie Klein-Reizes dies in London (Great Britain)
- Jahrbuch der Psychoanalyse* founded (Germany)
- A coordination committee of the Latin-American Organizations of Psychoanalysis (C.O.P.A.L.) is founded at the 3rd Latin-American Congress of Psychoanalysis, in Santiago, Chile, by the Argentine Societies of Psychoanalysis, from São Paulo and Rio de Janeiro, and from Chile and Mexico. President: Arnaldo Rascovsky (Chile)
- The Belgian Association of Psychoanalysts takes the name of Belgian Society for Psychoanalysis/Belgische Vereniging voor Psychoanalyse (Belgium)
- Estudios sobre técnica psicoanalítica* (Transference and Countertransference) by Heinrich Racker published (Argentina)
- 1961
- March 17 – The Canadian Institute of Psychoanalysis is officially incorporated in the province of Québec (Canada)
- June 6 – Carl Gustav Jung dies in Küsnacht (Switzerland)
- July 31–August 3 – 22nd Congress of the International Psychoanalytical Association in Edinburgh (Great Britain). President: William H. Gillespie. Elected President: Maxwell Gitelson. Affiliation of the Sociedad Colombiana de Psicoanálisis (Colombia) and the Asociación Psicoanalítica del Uruguay. The Study Group from Porto Alegre, patronized by the SPRJ, is recognized (Brazil). The French Society of Psychoanalysis obtains the status of Study Group under the sponsorship of an ad hoc committee (France)
- August 21 – Marco Levi Bianchini dies in Nocera Inferiore (Italy)
- The Centro de investigación y tratamiento Enrique Racker (Enrique Racker Center of Research and Treatment) founded by the Asociación Psicoanalítica de Argentina (APA) (Argentina)
- The *Revista de psicología y psicoterapia de grupo* founded (Argentina)
- 1962
- February 6 – Edmund Bergler dies in New York (USA)
- March 6 – René Laforgue dies in Paris (France)
- May 10 – Joan Riviere-Hogson Verrail dies in London (Great Britain)
- July 30 – The International Federation of Psychoanalytic Societies (I.F.P.S.) founded in Amsterdam by the Deutsche Psychoanalytische Gesellschaft, the Sociedad Psicoanalítica Mexicana, the Wiener Arbeitskreis für Tie-

- fenpsychologie, and the William Alanson White Psychoanalytic Society (Netherlands)
- September 21 – Marie Bonaparte dies in Saint-Tropez (France)
- The Rome Psychoanalytical Center founded by Emilio Servadio (Italy)
- Freud, the Secret Passion*, the film by John Huston, released (USA)
- Learning from Experience* by Wilfred R. Bion published (Great Britain)
- 1963
- July 28–August 1 – 23rd Congress of the International Psychoanalytical Association in Stockholm (Sweden). President: Maxwell Gitelson. Elected President: William H. Gillespie and Phyllis Greenacre, pro tem. The Study Group from Porto Alegre is recognized as the Sociedade Psicanalitica de Porto Alegre (SPPA) (Brazil). Affiliation of the Colombian Society of Psychoanalysis (Colombia)
- 1964
- March 8 – Franz Alexander dies in Palm Springs, California (USA)
- May 25 – The French Study Group founded, organized into the Psychoanalytical Association of France (APF), presided over by Daniel Lagache and descended from the French Society of Psychoanalysis, marking the second schism of the French psychoanalytical movement (France)
- June 21 – Jacques Lacan founds the École Française de Psychanalyse (French School of Psychoanalysis), which will be renamed École freudienne de Paris (Freudian School of Paris) in September 1964
- July 15 – Poul Bjerre dies in Göteborg, in Vårsta (Sweden)
- December 31 – Ronald Fairbairn dies in Edinburgh (Great Britain)
- The Institut und Ausbildungszentrum für Psychoanalyse und psychosomatische Medizin in Frankfurt-am-Main is named the Sigmund-Freud-Institut. The first director is A. Mitscherlich (Germany)
- Stig Björk and Veikko Tähkä create the IPA Study Group that will become the Finnish Psychoanalytic Society (Finland)
- First International Congress of Psychodrama in Paris, organized by Jacob Moreno (France)
- Papers on Psychoanalytic Psychology* by Heinz Hartmann, Ernst Kris, and Rudolf M. Loewenstein published (USA)
- 1965
- January 19 – French Society of Psychoanalysis (Société française de Psychanalyse) dissolved (France)
- July 25–30 – 24th Congress of the International Psychoanalytical Association in Amsterdam (Netherlands). President: William H. Gillespie and Phyllis Greenacre, pro temp. Elected President: P.J. van der Leeuw. The Psychoanalytical Association of France becomes constituent Society of the IPA (France). For the first time a Latin American is elected vice-president of the IPA
- The Associação Brasileira de Medicina Psicosomática (ABMP) founded in São Paulo. First president: Danilo Perestrello (Brazil)

- 1966
- February 3 – The éditions Gallimard with Jean-Bertrand Pontalis, the éditions Payot with Michel de M'Uzan and Marthe Robert, and the Presses universitaires de France with Jean Laplanche jointly undertake the publication of the complete works of Freud in French. The editorship will be granted to J. Laplanche and J.-B. Pontalis on April 12, 1967 (France)
- February 7 – Ludwig Binswanger dies in Kreuzlingen, canton of Thurgovia (Switzerland)
- October 2–3 – The Fédération Européenne de psychanalyse (FEP, European Psychoanalytical Federation) founded in Paris, under the impetus of Raymond de Saussure (Switzerland). Honorary President: Anna Freud. Secretary: Evelyne Kestemberg (France)
- The Sociedad Luso-española de Psicoanálisis spawns the Sociedad Española de Psicoálisis (Spain) and the Portuguese Study Group (Portugal)
- Publication of *Opere di Sigmund Freud* in twelve volumes begins under the direction of Cesare Musatti (Italy)
- Écrits* by Jacques Lacan published (France)
- 1967
- May 6 – The Associação Brasileira de Psicanálise (ABP) founded, joining four IPA societies into a federation. First president: Durval B. Marcondes, who has the *Revista Brasileira de Psicanálise* republished (Brazil)
- July 3 – James Strachey dies in London (Great Britain)
- July 24–28 – 25th Congress of the International Psychoanalytical Association in Copenhagen (Denmark). President: P.J. Van der Leeuw. The Australian Society of Psychoanalysis, branch of the British Psychoanalytic Society, gains the status of an IPA Study Group (Australia). A Work Group created in Venezuela
- October 9 – Jacques Lacan proposes under the name “la passe” an enabling process adapted to the Freudian School of Paris (France)
- Vocabulaire de la psychanalyse (The Language of Psychoanalysis)* by Jean Laplanche and Jean-Bertrand Pontalis published (France)
- The Canadian Psychoanalytic Society is organized into three branches: the Canadian Psychoanalytic Society (English Québec), called CPS (QE), the Société Canadienne de Psychanalyse (French branch), and the Canadian Psychoanalytic Society (Ontario)
- The Los Angeles Institute for Psychoanalysis becomes the Los Angeles Psychoanalytic Society and Institute (LAPSI) (USA)
- Société Médicale Balint founded (France)
- The Association des Psychanalystes du Québec (Quebec Association of Psychoanalysts) (A.D.P.Q.) founded with reference to Jacques Lacan
- The Empty Fortress: Infantile Autism and the Birth of the Self* by Bruno Bettelheim published (USA)
- 1968
- October – Serge Leclaire founds the Psychoanalysis Department at the University of Paris VIII, Vincennes, linked to the Center for the Teaching and Research of Philosophy. Creation of the U.E.R. of Human Sciences, clinics at the University of Paris VII by Juliette Favez-

- Boutonier, Jacques Gagey, and Claude Prévost joined by Jean Laplanche and Pierre Fédida (France)
- October 5 – Heisaku Kosawa dies in Tokyo (Japan)
- November 26 – Arnold Zweig dies in East Berlin (Germany)
- The Sigmund Freud-Gesellschaft (Sigmund Freud Society), founded in Vienna, with the support of Harald Leupold-Löwenthal and Hans Strotzka (Austria)
- The Swedish Society for Holistic Psychotherapy and Psychoanalysis (SSHPP), which will belong to the International Federation of Psychoanalytic Societies (IFPS) in 1972 (Sweden)
- An Association of Yugoslav Psychotherapists founded in Split at the impetus of Stjepan Betlheim (Yugoslavia)
- 1969
- March 17 – The Fourth Group founded—a French language psychoanalytical organization. President: François Perrier, Secretary: Piera Aulagnier (France)
- April 17 – Angélo Hesnard dies in Rochefort-sur-Mer (France)
- July 8 – The Belgische School voor Psychoanalyse/École belge de psychanalyse (Lacanian) (Belgian School for Psychoanalysis) founded by Antoine Vergote, Jacques Schotte, Paul Duquenne, Jean-Claude Quintart. Honorary President: Alphonse de Waelhens (Belgium)
- July 30–August 3 – 26th Congress of the International Psychoanalytical Association in Rome (Italy). Subject: “Recent developments in psychoanalysis.” President: P.J. Van der Leeuw. Elected President: Leo Rangell. Affiliation of the Società Psicanalitica Italiana (SPI). Affiliation of the Suomen Psykoanalyttinen Yhdistys (SPY, Finnish Psychoanalytic Society) (Finland). The founding of the European Psychoanalytical Federation officially recognized
- October 12 – Max Schur dies in New York (USA)
- December 31 – Theodor Reik dies in New York (USA)
- The conference of European psychoanalysts (in English—every two years) founded by the British Psycho-Analytical Society (Great Britain)
- The Círculo Psicanalítico do Rio de Janeiro founded (affiliated with the I.F.P.S.) (Brazil)
- The French-speaking branch from the Canadian Society of Psychoanalysis adopts the name Société psychanalytique de Montréal; it is recognized by the IPA in 1972 (Canada)
- The journal *Topique* founded by Piera Aulagnier (France)
- 1970
- April – *La Nouvelle Revue de Psychanalyse* (The New Review of Psychoanalysis) founded by Jean-Bertrand Pontalis (France)
- May 17 – Heinz Hartmann dies in Stony Point, New York (USA)
- May 20 – Hermann Nunberg dies in New York (USA)
- June – First annual scientific congress of the French branch of the Société Psychanalytique de Montréal (S.P.M.) (Canada)
- September 7 – Nicola Perrotti dies in Rome (Italy)
- December 14 – Edoardo Weiss dies in Chicago (USA)

December 31 – Michael Balint (Bálint, Mihály) dies in London (Great Britain)

Jean Laplanche founds a Laboratory for psychoanalysis and psychotherapy and in 1980 institutes a doctorate of psychoanalysis and psychopathology, University of Paris VII (France)

The International College of Psychosomatic Medicine founded (Canada)

The *Bulletin Intérieur de l'Association Psychanalytique de France*, created in 1964, becomes *Documents et Débats* (France)

*La construction de l'espace analytique* by Serge Viderman published (France)

1971

January 5 – Annie Reich dies in Pittsburgh (USA)

January 25 – Donald Winnicott dies in London (Great Britain)

May 1 – First Franco-British Colloquium in le Touquet (France), co-organized by the British Psycho-Analytical Society, the Psychoanalytical Association of France, and the Psychoanalytical Society of Paris

July – Sigmund Freud Museum, 19 Berggasse, inaugurated by Anna Freud, managed by the Sigmund Freud Gesellschaft (Austria)

July 26–30 – 27th Congress of the International Psychoanalytical Association in Vienna, the first in Austria since 1927. Subject: “The psychoanalytical concept of aggression: theoretical, clinical aspects and applications.” President: Leo Rangell. The Asociación Venezolana de Psicoanálisis (ASOVEP) is affiliated with the IPA (Venezuela). The Norwegian Society obtains the status of Study Group (Norway). The Australian Psychoanalytical Society obtains the status of Provisional Society (Australia)

October 19 – Raymond de Saussure dies in Geneva (Switzerland)

November 1 – Mosche Wulff (or Moshe Woolf) dies in Tel Aviv (Israel)

The Sociedade de Psicologia Clínica founded in Rio de Janeiro. The president is Maria Regina Domingues de Moraes (Brazil)

The Institute of Depth Psychology and Psychotherapy founded at the Vienna Faculty of Medicine, at Hans Strotzka's initiative (Austria)

*Lingüística, interacción comunicativa y proceso psicoanalítico* by David Liberman published (Argentina)

*Playing and Reality* by Donald W. Winnicott published (Great Britain)

1972

August 10 – Heinrich Meng dies in Basle (Switzerland)

August 16 – Edward Glover dies in London (Great Britain)

September – In September 1972, the British Psycho-Analytical Society is registered as a Charity No. 264314 (Great Britain)

December 3 – Daniel Lagache dies in Paris (France)

December 24 – Arminda Aberastury, called “La Negra,” dies in Buenos Aires (Argentina)



- December 26 – The Institut de Psychosomatique (Institute of Psychosomatic Medicine) founded by Michel Fain and Pierre Marty. It is comprised of a center for education and research in psychosomatic medicine (CERP) (France)
- The Scuola freudiana, of Lacanian orientation, founded by Giacomo Contri (Italy)
- The Toronto Psychoanalytic Society (TPS) and the Ottawa Psychoanalytic Society founded (Canada)
- Bulletin de la Fédération européenne de psychanalyse* (European Psychoanalytical Federation) founded. Editor-in-chief: Peter Hildebrand (Great Britain), Editorial staff: Michel de M'Uzan (France), Samir Stephanos (Germany), and Daniel Widlöcher (France)
- 1973
- July 22–27 – 28th Congress of the International Psychoanalytical Association in Paris (France). President: Leo Rangell. Elected President: Serge Lebovici, first French president of the IPA. Affiliation of the Australian Psychoanalytical Society (APS). The Mendoza Psychoanalytical Society is recognized as a Study Group
- December 16–19 – First international colloquium in Milan, organized by Armando Verdiglione (Italy)
- Centre Psychoanalytique Raymond de Saussure founded in Geneva (Switzerland)
- Le Discours vivant. La conception psychanalytique de l'affect* (The Living Discourse. The Psychoanalytical Conception of the Affect) by André Green published (France)
- 1974
- June 28 – The Escuela Freudiana de Buenos Aires (EFBA), of Lacanian orientation, founded with Oskar Masotta and Isodoro Vegh (Argentina)
- September 14 – René Spitz dies in Denver, Colorado (USA)
- October 31 – Congress of the Freudian School of Paris in Rome (Italy)
- The Cosa Freudiana, of Lacanian orientation, founded by Giacomo Contri, Muriel Drazien, Giuseppe Musotto (Palermo), and Armando Verdiglione (Italy)
- Center for the Development of Psychoanalysis founded (Peru)
- Göteborgs Psykoterapi Institut (Göteborg Psychotherapy Institute) founded by Angel and Dora Fiasché (Sweden)
- La jalousie amoureuse* by Daniel Lagache published (France)
- 1975
- July 20–25 – 29th Congress of the International Psychoanalytical Association in London (Great Britain). Subject: "Change in Psychoanalytic Practice and Experience: Theoretical, Technical and Social Implications" President: Serge Lebovici. Affiliation of the Norsk Psykoanalytisk Forening (NPF) (Norway)
- September 27 – Werner Kemper dies in Berlin (Germany)
- The Société Belge de psychologie analytique (S.B.P.A.) (Belgian Society of Analytical Psychology), of Jungian orientation, with Gilberte Aigrisse founded (Belgium)
- A Freud Professorship created at the University College in London (Great Britain)

- The Antilles Group for Psychoanalytical Research, Study and Training founded (GAREFP), with Héliane Bourgeois, Luce Descoueyte (Martinique)
- The Institute for Psychoanalysis of the Portuguese Society of Psychoanalysis founded (Portugal)
- A Hungarian Study Group founded (Hungary)
- Ornicar?* founded by Jacques-Alain Miller (France)
- L'auto-analyse de Freud et la découverte de la psychanalyse* (Freud's Self-Analysis and the Discovery of Psychoanalysis) by Didier Anzieu published (France)
- The Unconscious as Infinite Sets. An Essay in Bi-Logic* by Ignacio Matte-Blanco published (Chile)
- La violence de l'interprétation. Du pictogramme à l'énoncé* by Piera Castoriadis-Aulagnier published (France)
- 1976
- April 14 – Rudolph M. Loewenstein dies in New York (USA)
- July 30 – Sylvia May Payne dies in Tunbridge Wells, Sussex (Great Britain)
- The *Revista de la Sociedad Colombiana de Psicoanalisis* (Review of the Colombian Society of Psychoanalysis) founded (Colombia)
- The Austrian Society for the study of Child Psychoanalysis, founded in Salzburg (Austria)
- The International Freudian Movement founded by Armando Verdiglione in Milan (Italy)
- The review *Psychanalyse à l'université* created by Jean Laplanche (France)
- 1977
- July 16 – Enrique Pichon-Rivière dies in Buenos Aires (Argentina)
- July 21–26 – 30th Congress of the International Psychoanalytical Association in Jerusalem (Israel). President: Serge Lebovici. Elected President: Edward D. Joseph. Affiliation of the Asociación Psicoanalítica de Buenos Aires (A.P.D.E.B.A.) (Argentina). The Portuguese Study Group Portugais becomes a provisional Society (Portugal)
- August 10 – Grete Bibring-Lehner dies in Cambridge, Massachusetts (USA)
- August 25 – Sacha Nacht dies in Paris (France)
- October 27 – Therese Benedek dies in Chicago (USA)
- The Biblioteca Freudiana in Barcelona, of Lacanian orientation, founded with Oscar Masotta (Spain)
- A chair of psychoanalysis at the Hebrew University created in Jerusalem. Titular: Joseph Sandler (Israel)
- The Psychoanalytisches Seminar Zürich (Zurich Psychoanalytical Seminary) (P.S.Z.), of Lacanian orientation founded (Switzerland)
- 1978
- The Institute of Psychoanalysis of the Ottawa Psychoanalytic Society founded (Canada)
- The CPS/Western Canadian Branch created (Canada)
- 1979
- February – The Champ freudien (CF) founded by Jacques Lacan. Director: Judith Miller (France)

July 27 – 31st Congress of the International Psychoanalytical Association in New York (USA). Subject: "Clinical data in psychoanalysis." President: Edward D. Joseph. Affiliation of the Asociación Psicoanalítica de Madrid (Spain) and the Psychoanalytical Association of Buenos Aires (Argentina)

October 1–5 – Tbilisi Colloquium, at the initiative of L. Chertok and Philippe Bassine and under the sponsorship of the Georgian Academy of Sciences (Russia/USSR)

November 8 – Wilfred R. Bion dies in Oxford (Great Britain)

November 19 – Dorothy Burlingham-Tiffany dies in London (Great Britain)

November 24 – Ralph Greenson dies in Los Angeles, California (USA)

The Adelaide Institute of Psychoanalysis, a branch of the Australian Society of Psychoanalysis, founded with Dr. Harry Southwood (Australia)

Division 39 of the American Psychological Association founded (USA)

The Asociación Regiomontana de Psicoanálisis (A.R.P.A.C.) created to service northern Mexico

The Dutch Society of Psychoanalytical Psychotherapy founded (Netherlands)

The Center for the Development of Psychoanalysis (Peru)

Serie Psicoanalítica in Madrid, of Lacanian orientation, founded by Jorge Alemán (Spain)

1980

January 5 – The Freudian School of Paris dissolved by Jacques Lacan (France)

February 21 – Jacques Laçan founds the Cause freudienne, which becomes the École de la Cause freudienne, French School of Psychoanalysis, October 23, 1980 (France)

March 18 – Erich Fromm dies in Locarno (Switzerland)

June 6 – The Federación psicoanalítica de América latina (FEPAL) founded in Rio de Janeiro (Brazil). First president: Joel Zac

July 12–15 – Caracas Colloquium of the Champ Freudien, co-organized by Jacques Alain Miller and Diana Rabinovitch under the auspices of the Atenso de Caracas and the Paris Department of Psychoanalysis, Paris VIII (Venezuela)

July 29 – Adelheid Lucy Koch dies in São Paulo (Brazil)

November 3 – The College of Psychoanalysts founded. President: Dominique J. Geahchan (France)

November 23 – Marianne Kris-Rie dies in London (Great Britain)

The Sociedad Peruana de Psicoanálisis founded (Peru)

Creation of the Toulousan Group, tied to the Paris Psychoanalytical Society (France)

First translation of a work by Freud, *An Introduction to Psychoanalysis*, to be published in Romania

1981

July 20 – Abram Kardiner dies in Easton, Connecticut (USA)

July 26–31 – 32nd Congress of the International Psychoanalytical Association in Helsinki (Finland). Subject:

- “The first psychic development.” President: Edward D. Joseph. President elect: Adam Limentani. Affiliation of the Portuguese Society of Psychoanalysis. The Mendoza Society is promoted to Provisional Society (Argentina)  
September 27 – Durval Bellegarde Marcondes dies in São Paulo (Brazil)
- 1982
- January 28–30 – First Congress of Armando Verdiglione’s International Freudian Movement, in Rome (Italy). Subject: “Culture”  
March 29 – Helene Deutsch-Rosenbach dies in Cambridge, Massachusetts (USA)  
June – The Association freudienne, becoming thereafter the Association freudienne internationale, of Lacanian orientation, founded by Charles Melman (France)  
June 5 – South Western Ontario Psychoanalytic Society founded, sixth section of the Canadian Psychoanalytic Society (Canada)  
June 26 – Alexander Mitscherlich dies in Frankfurt am Main (Germany)  
July 9 – The Centre de Formation et de Recherches Psychanalytiques (C.F.R.P.) (Center for Training and Psychoanalytical Research) founded by Octave Mannoni, Maud Mannoni, and Patrick Guyomard (France)  
July 10–11 – First Psychoanalytical Meetings in Aix-en-Provence. Subject: “Suffering, Pleasure and Thought.” Presidents: Jacques Caïn and Alain de Mijolla (France)  
October – The Bulletin of the Paris Psychoanalytical Society founded by Michel Fain (France)  
October 9 – Anna Freud dies in London at the age of eighty-six (Great Britain)  
October 11 – Creation of a Study Group in Greece, recognized by the IPA (Greece)  
October 22 – Paula Heimann-Glatzko dies in London (Great Britain)  
The *Revue Belge de psychanalyse* (Belgian Review of Psychoanalysis) founded. Director: Maurice Haber (Belgium)  
Congress of the fiftieth anniversary of the founding of the Società Psicoanalitica Italiana (S.P.I.), in the presence of the president of the Republic Pertini, in Rome (Italy)
- 1983
- July 25–29 – 33rd Congress of the International Psychoanalytical Association in Madrid (Spain). Subject: “The psychoanalyst at work.” President: Adam Limentani. Affiliation of the Asociación Psicoanalítica de Mendoza (APM) (Argentina). The Hungarian Psychoanalytical Society becomes a Provisional Society (Hungary)  
December – The International Society of the History of Psychiatry, created in December 1982, adds to its name “and Psychoanalysis.” Directors: Michel Collée, Claude Quézel, and Jacques Postel (France)  
Lima Center of Psychoanalytical Psychotherapies founded (Peru)
- 1984
- June – The group “Psychoanalysts for the Prevention of Nuclear War” founded by Hanna Segal (Great Britain)  
“Werkstatt für Psychoanalyse und Gesellschaftskritik” (Workshop for Psychoanalysis and Social Criticism) created in Salzburg (Austria)

- The bilingual review *Psycho-analyse* founded by the l'École Belge de Psychanalyse (Belgian School of Psychoanalysis) (Belgium)
- Psychoanalytic Center of California founded by James Gooch (USA)
- L'image inconsciente du corps* (The Unconscious Image of the Body) by Françoise Dolto published (France)
- 1985
- February 6 – Muriel M. Gardiner dies in Princeton, New Jersey (USA)
- March – A public lawsuit is filed by four psychologists within the framework of an antitrust law against the American Psychoanalytic Association, the New York Psychoanalytic Institute, the Columbia University Center for Psychoanalytic Training and Research, and the International Psychoanalytical Association for “restrictive practices and monopolies at state and international levels in the presentation materials and psychoanalytical services delivered to the public.” A negotiated settlement is reached in October 1988 (USA)
- May 20 – Franco Fornari dies in Milan (Italy)
- June 25 – Association Internationale d'Histoire de la Psychanalyse (AIHP-IAHP) (International Association of the History of Psychoanalysis) founded by Alain de Mijolla (France)
- July 28–August 2 – 34th Congress of the International Psychoanalytical Association in Hamburg (Germany). Subject: “Identification and its vicissitudes.” President: Adam Limentani. Elected President: Robert S. Wallerstein. The Peruvian Society of Psychoanalysis will acquire the status of Provisional Society (Peru)
- September 27 – Eugenio Gaddini dies in Rome (Italy)
- October 2 – Margaret Mahler-Schönberger dies in New York (USA)
- November 20 – Pieter van der Leeuw dies in Amsterdam (Netherlands)
- The Association des psychothérapeutes psychanalytiques du Québec (Quebec Association of Psychoanalytical Psychotherapists) founded (A.P.P.Q.) (Canada)
- The association Le texte freudien founded by Jalil Benani (Morocco)
- The *Portuguese Review of Psychoanalysis* founded by the Portuguese Society of Psychoanalysis (Portugal)
- 1986
- March 22 – Inauguration of the new seat of the International Psychoanalytical Association in “Broomhills” by Adam Limentani, William H. Gillespie, and Robert S. Wallerstein (Great Britain)
- May 6 – The Institut de Psychanalyse and the Société Psychanalytique de Paris merge into a single society. President: André Green (France)
- July 17 – The second chamber of the correctional tribunal in Milan condemns Armando Verdiglione to four and a half years in prison. After an appeal, he is released tentatively on February 18, 1987 (Italy)
- July 28 – Inauguration of the Freud Museum in London, by Princess Alexandra of Kent (Great Britain)
- October 27 – Herbert Rosenfeld dies in London (Great Britain)

- The Réseau des cartels, of Lacanian orientation, founded by François Peraldi (Canada)  
 The Center for Psychoanalysis and Society founded (Peru)
- 1987
- 5 April – Jeanne Lampl-de Groot dies in Schiedam (Netherlands)
- May 1–3 – 1st International Meeting of the Association Internationale d'Histoire de la Psychanalyse (International Association of the History of Psychoanalysis) (AIHP-IAHP) in Paris. Subject: "Psychoanalysis and psychoanalysts during the Second World War." President: Alain de Mijolla (France)
- July 26–31 – 35th Congress of the International Psychoanalytical Association in Montréal (Canada). Subject: "Analysis Terminable and Interminable: Fifty Years Later." President: Robert S. Wallerstein. Affiliation of the Psychoanalytical Society of Peru (Peru)
- 1988
- May – The first issue of the *Revue internationale d'histoire de la psychanalyse* published (1988–1993). Editor: Alain de Mijolla
- August 25 – Françoise Dolto-Marette dies in Paris (France)
- The Société psychanalytique de Québec founded, branch of the Société canadienne de psychanalyse – Canadian Psychoanalytic Society (Canada)
- The Bulletin of the Montreal Psychoanalytical Society founded (Canada)
- 1989
- February 10 – Danilo Perestrello dies in Rio de Janeiro (Brazil)
- March 20 – Cesare Musatti dies in Milan (Italy)
- April 1 – Evelyne Kestemberg-Hassin dies in Paris (France)
- June 8 – Masud R. Khan dies in London (Great Britain)
- July 30 – Octave Mannoni dies in Paris (France)
- July 30–August 4 – 36th Congress of the International Psychoanalytical Association in Rome (Italy). Subject: "Common bases of psychoanalysis." President: Robert S. Wallerstein. Elected President: Joseph Sandler. Affiliation of the Hungarian Society of Psychoanalysis (Hungary) and the Australian Psychoanalytical Society (Australia). The New York Freudian Society (NYFS), the California Psychoanalytical Center, and the Psychoanalytical Training and Research Institute (New York) become Provisional Societies (USA)
- August 23 – Ronald Laing dies in Saint-Tropez (France)
- September 23 – Worldwide ceremonies for the fiftieth anniversary of Freud's death
- October – Angel Garma is decorated in Buenos Aires by the Spanish Ambassador in the name of King Juan Carlos with the Great Cross of Civil Merit (Spain–Argentina)
- October 7 – Ruth Eissler-Selke dies in New York (USA)
- October 21 – Homage paid to Wilfred Bion, on the tenth anniversary of his death, Francesca Bion presides (France)
- October 24 – Phyllis Greenacre dies in Ossining, New York (USA)

October 24 – Richard F. Sterba dies in Grosse Pointe, Michigan (USA)

November 25–26 – 1st Italian-French psychoanalytical colloquium organized by the Italian Society of Psychoanalysis and the Paris Psychoanalytical Society. Subject: “Contretransference and transference” (France–Italy)

December 15 – The APUI, “Association pour une instance,” founded by Serge Leclair, Jacques Sédat, Danièle Lévy, Lucien Israël, and Philippe Girard (France)

Signing of a compromise bringing the American Psychoanalytic Association and the International Psychoanalytic Association to admit qualified American psychologists and non-medical psychoanalysts (USA)

The Wiener Psychoanalytische Vereinigung (Viennese Psychoanalytical Society) belongs to the “Dachverband für Psychotherapie” (Umbrella Organization for Psychotherapy) and will participate in the “Psychotherapiebeirat” (Psychotherapy Advisory Board) (Austria)

The Sociedade de Psicologia Clínica, of Rio de Janeiro, takes the name of Sociedade de Psicanálise da Cidade (Brazil)

Mary S. Sigourney Award established. The first laureates are Jacob A. Arlow, Harold Blum and Otto Kernberg (USA)

A Forum Brasileiro de Psicanálise founded (Brazil)

The “Société Algérienne de Recherches en Psychologie” (Algerian Society of Research in Psychology) founded by M.A. Aït Sidhoum, F. Arar, and D. Haddadi (Algeria)

The European Interassociative of Psychoanalysis, of Lacanian orientation, founded (Europe)

The Psychoanalysis and Culture Foundation created (Netherlands)

The Iberian Congress of Psychoanalysis founded, bi-annually gathering the Madrid Psychoanalytic Association, the Spanish Psychoanalytic Society, and the Portuguese Psychoanalytic Society. An Iberian directory of psychoanalysis in the Castilian language published (Spain–Portugal)

The review *Psychoanalytický sborník* created by the future IPA Czech Study Group (Czech Republic)

1990

February 15 – The Psychanalytic Association of the USSR founded in Moscow by Aaron Belkine (Russia)

March 13 – Bruno Bettelheim commits suicide in Silver Spring, Maryland (USA)

March 31 – Piera Aulagnier-Spairani dies in Paris (France)

April 7 – Celes E. Cárcamo dies in Buenos Aires (Argentina)

July 18 – Karl A. Menninger dies in Topeka, Kansas (USA)

September 2 – E. John Bowlby dies in Skye Ball (Great Britain)

September 5 – Luisa Gambier de Alvarez de Toledo dies in Buenos Aires (Argentina)

September 22–23 – A European School of psychoanalysis founded in Barcelona, by Jacques-Alain Miller, E. Laurent, and C. Soler. It is linked to the Ecole de la Cause (France–Spain)

- December – The Association Forum founded by Benedetta Jumpertz, Marcel Manquant, and Guillaume Sur-éna (Martinique)  
 The Société d'Études et de Recherches en Psychanalyse (Society for Study and Research in Psychoanalysis) founded by Mohamed Halayem (Tunisia)  
 Romanian Psychoanalytical Society founded (Romania)
- 1991
- March – First colloquium of psychoanalysis in Martinique organized by the association FORUM (Martinique)  
 July 28–August 2 – 37th Congress of the International Psychoanalytical Association in Buenos Aires (Argentina), first congress in Latin America. Subject: “Psychic Change: developments in theory of psychoanalytical technique.” President: Joseph Sandler. La Sociedad Psicoanalítica de Caracas is recognized as a Provisional Society (Venezuela)  
 September 6 – Robert J. Stoller dies in Los Angeles (USA)  
 September 24 – Edward D. Joseph dies (USA)  
 September 30 – Martin Grotjahn dies in Los Angeles (USA)  
 November 3 – Serge Viderman dies in Paris (France)  
 A Committee for the IPA archives and history founded by Joseph Sandler  
 The Polish Society for the Development of Psychoanalysis founded (Poland)
- 1992
- February 1 – World Association of Psychoanalysis (WAP) founded in Paris (France), by Jacques-Alain Miller. It unites the Escuela del Campo Freudiano of Caracas (ECF, Caracas, 1985), the École européenne de psychanalyse (EEP, Barcelona-Paris, 1990), the Ecole de la Cause Freudienne (France, 1981), and the Escuela de la Orientacion del Campo Freudiano (Buenos Aires, Argentina, 1992)  
 November 1 – The Association de la Cause freudienne (A.C.F.) founded by Jacques-Alain Miller (France)  
 The bilingual review *Canadian Journal of Psychoanalysis/Revue Canadienne de Psychanalyse* founded. Editor-in-chief: Eva Lester, of Montreal (Canada)  
 Wissenschaftliche Gesellschaft der Arbeitskreise für Psychoanalyse in Österreich (Scientific Society of work circles for psychoanalysis in Austria) and its journal *Texte. Psychoanalyse. Ästhetik. Kulturkritik*, edited by E. List, J. Ranefeld, G.F. Zeilinger, and A. Ruhs, founded (Austria)  
 The journal *International Forum of Psychoanalysis* founded by the International Federation of Psychoanalytic Societies (I.F.P.S.)  
 Institute of Psychoanalysis and Psychotherapy founded by Katarzyna Walewska (Poland)  
 Freudian Praxis of Lacanian orientation founded in Athens (Greece)
- 1993
- January 29 – Angel Garma dies in Buenos Aires (Argentina)  
 June 14 – Pierre Marty dies in Paris (France)



- July 25–30 – 38th Congress of the International Psychoanalytical Association in Amsterdam (Netherlands). Subject: “The psychoanalyst’s mind: from listening to interpretation.” President: Joseph Sandler. Elected President: Horacio Etchegoyen (first South American president). Affiliation of the Institute for Psychoanalytic Training and Research of New York (USA), the Monterey Psychoanalytic Society (USA), the New York Freudian Society (NYFS) (USA), and the Psychoanalytic Center of California (USA). The Associazione Italiana di Psicoanalisi (A.I.Psi), created in 1992 by E. Servadio and A. Giannotti (Italy), is recognized as a Provisional Society. The Asociación Regiomontana de Psicoanálisis (A.R.P.A.C.) is recognized as an independent affiliated member (Mexico). The Czech Group becomes a Study Group (Czech Republic)
- The Wiener Psychoanalytische Vereinigung (W.P.V., Viennese Psychoanalytical Society) is recognized as first training organization in the framework of legislation on psychotherapy voted upon in 1992 (Austria)
- 1994
- May – The École de Psychanalyse Sigmund Freud (Sigmund Freud School of Psychoanalysis), of Lacanian orientation, founded (France)
- May 12 – Erik Homburger Erikson dies in Cape Cod, Massachusetts (USA)
- July 25–26 – First Meeting of the House of Delegates at the International Psychoanalytical Association in London. President: Henk Jan Dalewijk (Great Britain)
- August 8 – Serge Leclair (Liebschutz) dies in Argentine, Haute-Savoie (France)
- October 16 – Espace analytique (Analytical Space) founded by Maud Mannoni (France)
- October 29 – Willy Baranger dies in Buenos Aires (Argentina)
- November 11 – Frances Tustin dies in London (Great Britain)
- Emilio Servadio dies in Rome (Italy)
- The École belge de psychanalyse jungienne (E.B.P.J.) (Belgian School of Jungian Psychoanalysis) founded (Belgium)
- Frankfurter Psychoanalytische Institut founded, affiliated with the Deutsche Psychoanalytische Vereinigung (Germany)
- Sigmund Freud Library opened by the Paris Psychoanalytical Society (France)
- 1995
- January 11 – Ignacio Matte-Blanco dies in Rome (Italy)
- February – Société de psychanalyse freudienne (Society of Freudian Psychoanalysis) founded by Patrick Guyomard (France)
- June – The Escola Brasileira de Psicanálise do Campo Freudiano (E.B.P.), member of the Global Association of Psychoanalysis, founded in Rio de Janeiro, at the impetus of Jacques-Alain Miller (Brazil)
- July 30–August 4 – 39th Congress of the International Psychoanalytical Association in San Francisco (USA). President: Horacio Etchegoyen. Elected President: Otto Kernberg. Affiliation of the Sociedad Psicoanalítica de Caracas (Venezuela), Sociedad Psicoanalítica de Cor-

- doba (Argentina) and of the Los Angeles Institute and Society for Psychoanalytic Studies (USA). The Sociedade Psicanalítica de Recife and the Sociedade Psicanalítica de Pelotas are recognized as Provisional Societies (Brazil)
- December 12 – Cyro Martins dies in Porto Alegre (Brazil)
- Federation of Independent Psychoanalytic Societies (FIPAS) founded by independent psychoanalysts of Southern California (USA)
- The psychoanalytical institutes of the Netherlands Psychoanalytic Society and the Netherlands Association for Psychoanalysis merge into the Netherlands Psychoanalytic Institute (NPI) (Netherlands)
- 1996
- September 30 – Latin-American Association of the History of Psychoanalysis founded by Gilda Sabsay y Foks (Argentina)
- October 17–19 – First European Congress of Psychopathology of the Child and the Adolescent in Venice (Italy)
- 1997
- July 27–August 1 – 40th Congress of the International Psychoanalytical Association in Barcelona (Spain). Subject: “Psychoanalysis and Sexuality.” President: R. Horacio Etchegoyen. Affiliation of the Italian Association of Psychoanalysis (Italy). The Porto Alegre Study Group (Brazil) and the Hellenic Group of Psychoanalysis (Greece) are recognized as Provisional Societies. Formation of the Polish Psychoanalytical Study Group, the psychoanalytical center of Mato Grosso do Sul à Campo Grande, and the third group from Buenos Aires that will form the Argentine Psychoanalytical Society (SAP)
- August 20 – Paris Psychoanalytical Society is recognized for “public service” by a decree published in the official journal of the French Republic (France)
- October – First issue of *Psychoanalysis and History*. Editor: Andrea Sabbadini (Great Britain)
- November 2 – René Diatkine dies in Paris (France)
- Archives of the International Federation of Psychoanalytic Societies (I.F.P.S.) founded for the history of psychoanalysis
- 1998
- March 15 – Maud (Magdalena) Mannoni-van der Spoel dies in Paris (France)
- April 3–5 – First Psychoanalytical Conference in South Africa, organized in Cape Town by the South African Psychoanalytical Society. Subject: “Change: Psychoanalytic Perspectives” (South Africa)
- May 29 – Marion Milner-Blackett dies in London (Great Britain)
- August 14 – Gisela Pankow dies in Berlin (Germany)
- October 3 – Foundation of Convergencia, a Lacanian movement for Freudian psycholanaysis in Barcelona (Spain)
- October 6 – Joseph Sandler dies in London (Great Britain)
- October 14 – Opening of “Sigmund Freud: Conflict and Culture,” exhibition at the Library of Congress in Washington (USA)

- 1999  
 February 17 – Kurt Eissler dies in New York (USA)  
 July 25–30 – 41st Congress of the International Psychoanalytical Association in Santiago (Chile). Subject: “Affect in theory and practice.” President: Otto Kernberg. Affiliation of the Recife Psychoanalytical Society (Brazil). Recognized as Provisional Societies—the Brasília Psychoanalytical Study Group, the Study Group of the Colombian Psychoanalytical Association and the Prague Study Group. The Romanian Psychoanalytical Study Group is recognized, as is the Psychoanalytical Study Group visiting from South Korea.  
 November 25 – Didier Anzieu dies in Paris (France)
- 2000  
 February 2 – Wladimir Granoff dies in Paris (France)  
 August 12 – Serge Lebovici dies in Marvejols (France)
- 2001  
 June 30 – William H. Gillespie dies (Great Britain)  
 July 22–27 – 42nd Congress of the International Psychoanalytical Association in Nice (France). Subject: “Psychoanalysis: Method and Practice.” President: Otto Kernberg. Elected President: Daniel Widlöcher. The Deutsche Psychoanalytische Gesellschaft is admitted as a Provisional Society (Germany)  
 September 11 – Terrorist attack on the World Trade Center in New York and the Pentagon in Washington (USA)  
 December 7 – Moroccan Psychoanalytic Society founded in Rabat. President: Jalil Bennani (Morocco)
- 2002  
 February 9–10 – First Franco-Argentine colloquium in Paris (France), organized by the Argentine Psychoanalytical Association (APA) and the Paris Psychoanalytical Society (SPP). Subject: “The Framework in Psychoanalysis”  
 November 1 – Pierre Fédida dies in Paris (France)
- 2003  
 December 27 – Jean Cournut dies in Paris (France)
- 2004  
 March 9–14 – 43rd Congress of the International Psychoanalytical Association in New Orleans (USA). President: Daniel Widlöcher. Elected President: Cláudio Laks Eizirik  
 May 21 – Jacob A. Arlow dies in New York (USA)  
 August 9 – Article 57 of the August 9, 2004 law allows the use of the title of psychotherapist by “psychoanalysts regularly registered in their associations’ directories” (France)



## “A. Z.”

“A. Z.” is the pseudonym used by the author of “Tratamiento psicoanalítico de un caso de neurosis compulsiva” (Psychoanalytic treatment of a case of compulsive neurosis), a text published in Peru in 1919 in *Revista de psiquiatría y disciplinas conexas* (Review of psychiatry and associated disciplines).

The first account of psychoanalytic treatment ever published in Spanish, this case history concerned a thirty-year-old patient with a curious “intermittent obsession related to double vision produced by a strabismus resulting from incorrectly performed tenotomies; an obstinate attachment to the false (unclear and deflected) image perceived by the eye affected. The subject felt subjectively attracted by this sensation.” Having tried in vain to relieve his malaise in Europe the patient undertook a course of treatment with the author, who came to the conclusion that the patient persisted in seeing the false image in order to avoid confronting the fantasies that derived from his perverse infantile polymorphism.

There is strong evidence to suggest that “A. Z.” was the dermatologist Carlos Aubry (1882–1996), a physician known to have been so eccentric and unmercenary that he died penniless, having refused to accept payment from his patients. Valdizán (1923) states in his *Diccionario*: “Apart from his specialty [dermatology], he mastered several psychological disciplines, as witnessed by his contribution to the Review.” Aubry confined himself to reports and never published another article in the Review. His thesis (1906) dealt with the reflex of convergence, and the use of striped projection to illustrate double vision.

ÁLVARO REY DE CASTRO

*See also:* Obsessional neurosis; Peru.

## Bibliography

A. Z. (1919). Tratamiento psicoanalítico de un caso de neurosis compulsiva. *Revista de psiquiatría y disciplinas conexas*, II (1), p. 22–25.

Rey de Castro, Álvaro. (1991). Freud y Honorio Delgado: una aproximación psicoanalítica a la prehistoria del psicoanálisis peruano y sus escuelas. *El múltiple interés del psicoanálisis—77 años después*, Talleres de Artes Gráficas Espino, p. 203–237.

Valdizán, Hermilio. (1923). *Diccionario de medicina peruana*. t. I, Lima, Talleres gráficos del asilo “Victor Larco Herrera,” p. 346.

---

## ABANDONMENT

Strictly speaking, the notion of abandonment is not a psychoanalytic concept. It was initially applied in situations where very young children were deprived of care, education, and affective support, and were neglected by or separated prematurely from their maternal environment, with no reference to the causes of this deprivation. From a purely descriptive point of view, pediatricians and psychologists taking an interest in child development have long recognized the somatic and psychic effects of such states of deprivation.

The notion is nevertheless appropriately included in a dictionary of psychoanalysis, for two reasons. Firstly, the concept of abandonment is not applied solely to children, but also to adults who experience the feeling of abandonment, separation, or bereavement, whether real or imaginary. Secondly, certain

psychoanalysts very quickly developed an interest in the mental disorders and disturbances observed in the emotional development of children subjected to such traumatic experiences, as well as the possible pathogenic role of the family environment. Abandonment raises the fundamental problem of object loss and renunciation of the love object, or the work of mourning. It also calls into question the metapsychological status of anxiety.

In a primary and passive sense, abandonment refers to the experience of a state that is imposed by loss or separation: being or feeling abandoned. In a secondary and active sense, the complement of the previous one, it applies to the psychic process that leads a person to deny the cathected object, separate from it, and abandon it.

Published in 1950, Germaine Guex's *La Névrose d'abandon* (Abandonment neurosis) contributed considerably to propagating the notions of the abandonment complex and the abandonment-type personality. Although now dated, this work nevertheless had the virtue of stressing the influence of disturbances and conflicts occurring during pre-oedipal phases of psychic development in the causation of certain forms of neurotic character disorders and depression, which Guex related to affective frustration experienced during childhood, essentially in relation to the mother. Subjects thus frustrated turn out to be both affectively insatiable and extremely dependent on others, so that every separation is a major crisis for them. Other more recent writers, particularly Otto Kernberg and Heinz Kohut, have studied narcissistic personality disorders and borderline states between neurosis and psychosis from a similar perspective. They stress the difficulties that arise when the analytic treatment of these patients reproduces their affective dependence in the transference, thus rendering the analysis interminable.

Among clinical work by child psychoanalysts we have to bear in mind Anna Freud's and Dorothy Burlingham's observations of young children who were separated from their families during World War II, as well as René Spitz's work on the severe consequences of hospitalism and anaclitic depression in infants. John Bowlby's study of children's mourning led to attachment theory, which is amply developed in a book that is both a comprehensive survey and a reference, although his views are sometimes closer to psychobiology and behaviorism than to psychoanalysis.

Abandonment is also at the root of a certain number of asocial or delinquent behaviors linked to educational deprivation and indicating a defect in the organization of the ego and the superego. On this subject Donald Winnicott referred to the "antisocial tendency" as an alarm signal that is sounded by distressed children. These problems had already attracted the attention of some of Freud's collaborators in the period between the two World Wars. In Austria in the 1920s August Aichhorn initiated an educational experience in the light of analytic practice and aimed at children who were victims of exclusion. His book *Verwahrloste Jugend* (1925) (*Wayward Youth*, 1935), prefaced by Freud, recounts this experiment, which still retains much of its pertinence.

Psychoanalysis must never underestimate the importance of objective reality either in theory or practice, but it owes it to itself to remain especially attentive to the manifestations of unconscious psychic reality, to the activity of the representations and fantasies that constitute it, and to its verbal and affective modes of expression in conscious life. From this point of view, abandonment or separation anxiety is an inevitable condition of existence that appears very early on in the course of psychic development and whose ongoing influence varies from one individual to the other, depending on the situations they encounter. In his second theory of anxiety, as outlined in *Inhibitions, Symptoms, and Anxiety* (1926d [1925]), Freud shows that for the ego, the emergence of this affect takes on the value of a danger signal, a danger that may be real or imaginary, but whose prototype is the threat of castration linked to the development of the Oedipus complex. Here the ego feels threatened with the loss of the love object or the loss of the love of the object.

According to Freud, this fundamental anxiety expresses the original state of distress (*Hilflosigkeit*, literally: helplessness) linked to the prematurity of an individual at the start of life, which renders him or her completely dependent on another for the satisfaction of both vital and affective needs. The resulting need to feel loved will never cease throughout life. This need seems to be more narcissistic than object related because through it is expressed a nostalgic desire that precedes any differentiated object relationship: the desire to recover, in a fantasied fusion with the mother, a state of internal well-being and complete satisfaction, protected from the outside world, free of all conflict,

of all ambivalence and all splitting. For Melanie Klein, the internal feeling of loneliness is born out of the inevitable dissatisfaction of this aspiration for an impossible narcissistic completeness, one that takes the form of a definitively unattainable ideal. However, the feeling of being alone can also be a source of satisfaction for the child, marking the acquisition, through games for example, of a certain degree of autonomy in relation to the presence of the mother. Donald Winnicott stressed this capacity to be alone in the presence of the mother, which he considered to be a decisive stage in the evolution of the child.

Over and above the shock it produces, object loss initiates a process of intrapsychic work, which Freud identified as the work of mourning and which results, in the best cases, in renunciation of the lost object. But the success of this long and painful process is quite variable, depending on the individual, the degree of maturation of the psychical apparatus, and the solidity of the narcissistic organization. Bereavement or loss often leave indelible traces on the ego, a sense of being abandoned is only one of many aspects, since mourning is clinically multifaceted. In his 1915 essay, *Mourning and Melancholia* (1916–17g [1915]), Freud compares two responses, in order to better highlight their differences in relation to the loss of the object and the ambivalence of the ego with respect to it. In melancholia, the lost object is neither conscious nor real: it is a part of the ego, unconsciously identified with the lost object, which becomes the target for guilt feelings and self-accusing projections. “The shadow of the object fell upon the ego,” wrote Freud (p. 249). But it must be added that all mourning, all loss, all separation, affects the ego at its narcissistic base: being separated from the object is also being deprived of a part of one’s self (Rosolato, 1975).

Logically, we should differentiate more between the work of mourning (with the tragic dimension given by the death of the object), and the work of separation (which brings into play the presence, whether real or imaginary, of a third party separator and does not mobilize the same affects as mourning). Additionally, separation, with all the intrapsychic conflicts it gives rise to, is a normal process that leads to the individuation and autonomy of the child. It is the father, in this case, or the authority replacing him, who is the third party separator. Lastly, the problem of separation and abandonment is not merely a question of vicissitudes in the primary relation with the mother. Freud insisted

on the crucial importance of the need to be protected by the father, and on the intensity of the feeling of nostalgia that is directed toward him in his absence. He considered the identification with the prehistoric father as a “direct and immediate identification” that “takes place earlier than any object-cathexis” (1923b, p. 31). Clinical experience of depression both in adults and children confirms the importance of the feeling of being abandoned by the father, and of the absence of the father in the mother’s desire.

JEAN-CLAUDE ARFOUILLOUX

*See also:* Aichhorn, August; Guex, Germaine; Helplessness; Hospitalism; Spitz, René Arpad.

### **Bibliography**

- Aichhorn, August. (1935). *Wayward youth*. New York: The Viking Press.
- Bowlby, John. (1969). *Attachment and loss*. London: Hogarth.
- Freud, Sigmund. (1916–17g [1915]). Mourning and melancholia. *SE*, 14: 237–258.
- (1923b). The ego and the id. *SE*, 19: 1–66.
- (1926d [1925]). Inhibitions, symptoms and anxiety. *SE*, 20: 75–172.
- Guex, Germaine. (1950). *La Névrose d'abandon: le syndrome d'abandon*. Paris: Presses Universitaires de France.
- Klein, Melanie. (1959). On the sense of loneliness. In her *Envy and Gratitude and Other Works, 1946–1963*. New York: The Free Press.
- Rosolato, Guy. (1975). L'axe narcissique des dépressions. *La Relation d'inconnu*. Paris: Gallimard.

### **Further Reading**

- Pollock, George H. (1988). Notes on abandonment, loss, and vulnerability. *Annual of Psychoanalysis*, 16, 341–370.

---

## **ABEL, CARL (1837–1906)**

Carl Abel was a German linguist known for his research on Indo-European and Hamito-Semitic lexicology, which was published in his *Einleitung in ein Aegyptisch-semitisch indoeuropäisches Wurzelwörterbuch* (1886).

It was his theory of the “opposite meanings of primitive words” that interested Freud when, after alluding to the idea in the *Interpretation of Dreams* (1900a), he wrote an article on the subject ten years later,

entitled "The Antithetical Meaning of Primal Words" (1910e). The theory appeared in Abel's article "Über den Gegensinn der Urworte," which appeared in *Sprachwissenschaftliche Abhandlungen*, published in Leipzig in 1885.

Basing his thesis on the fact that a Latin word such as *sacer* signified both "sacred" and "taboo," Abel proposed a theory of the way vocabulary evolves in languages. For Abel, a word in its primitive state can have opposite meanings, which are gradually distinguished through the progress of the rational intellect. "When learning to think about force, we have to separate it from weakness; to conceive of darkness, we must isolate it from light."

For Freud, primitive words mark a stage of symbolization that precedes the separation of opposites brought on by the reality principle. This cultural phenomenon is comparable to the dream process, which enables a representational content to assume a value as the expression of a desire and an antithetical desire. Consequently, the logic of the primary process is felt in a cultural formation as fully developed as language.

Is there a linguistic basis to Abel's theory? Some eminent linguists such as Émile Benveniste have claimed the entire theory to be false. If Latin has only one word for "sacred" and "taboo," they claim, it is because Roman culture doesn't differentiate between them. It is translation that creates the illusion of opposite meanings. According to Benveniste, the Latin concept corresponding to the word *sacer* simply characterizes a field that extends beyond the frontiers of the human and constitutes the undifferentiated domain of the sacred and the taboo.

Benveniste's reasoning is rigorous but it is worth pointing out that there are rhetorical figures such as euphemism or antiphrasis designed to create a reversal of meanings similar to that of primitive words. So when someone remarks of an idiot "What a genius!," they assign an antiphrastic value to the word "genius," which, in conjunction with its primary value, turns the signifier "genius" into a good example of a primitive word combining the opposite meanings of "intelligent" and "stupid." The fact remains, however, that the rhetorical figure is based on an initial disjunction of opposite values rather than the confusion that Abel assigns to his construction. For we can only refer to an idiot as a "genius" if "genius" initially means genius, not if the term refers to any unit that incorporates the meanings of both "genius" and "idiot." The process

works by an enrichment of the opposite meanings assigned from the outset. It is also possible that the lack of differentiation that occurs in dreams results in a conjunction of opposed values that is closer to the mechanism described above than to any initial blurring, which, according to Abel, is characteristic of the meanings of primitive words.

LAURENT DANON-BOILEAU

*See also:* Linguistics and psychoanalysis; Reversal into the opposite.

### **Bibliography**

Abel, Carl. (1885). Über den Gegensinn der Urworte. *Sprachwissenschaftliche Abhandlungen*, 313–367.

Freud, Sigmund. (1900a). The interpretation of dreams. *SE*, 5: 1–338; *SE*, 5: 339–625.

———. (1910e). The antithetical meaning of primal words. *SE*, 11: 155–161.

---

## **ABERASTURY, ARMINDA, KNOWN AS "LA NEGRA," (1910–1972)**

The Argentine psychoanalyst Arminda Aberastury was born on September 24, 1910, in Buenos Aires, and died there on December 24, 1972, by committing suicide. Because of her dark hair she was affectionately known as "La Negra," and it was this name that others used when they referred to her.

In 1937 she married the psychiatrist Enrique Pichon-Rivière, a pioneer of psychoanalysis in Argentina. The couple had three children: Enrique, Joaquin, and Marcelo. In 1953, she became a training analyst with the Asociación psicoanalítica argentina (APA). She taught for nearly twenty years at the Teaching Institute, where she was the director, and introduced the teaching of child psychoanalysis as part of the training of the analyst candidate.

She later held the chair of child and adolescent psychology in the School of Philosophy and Literature at the University of Buenos Aires. In Latin America she distributed psychoanalytic information to pediatricians, child care workers, teachers, doctors, and pediatric dentists. She corresponded with Melanie Klein, whom she met in London in 1952. She translated Klein's *The Psychoanalysis of Children* and became a spokeswoman for Klein's theories.

Aberastury believed that genital libido developed before the anal stage, leading to the existence of a “primary genital stage,” chronologically situated between the sixth and eighth month of life, which became a key theoretical concept for psychoanalysis. The growth of genital instincts, weaning, teething, the development of the musculature, learning to walk, the acquisition of language, the disruption of the mother-child symbiosis were all said to constitute a complementary series that structured this phase of development, and which would explain specific symptoms and dysfunctions. The genital origin of erogenous manifestations was found in the activity of play. The theory, which included genital identity and the father in the mother-child relation from the first moments of life, helped refine Kleinian theory. Aberastury’s ideas on paternity were published posthumously.

The chair of pediatric dentistry in Buenos Aires provided Aberastury with an excellent opportunity for developing and applying her theories. It was here at the Hospital Británico that she began to make use of psychodrama and group psychotherapy in her work with children. Aberastury extended the treatment to their guardians, basing her methods on her observations of the application of psychoanalysis to groups of fathers and mothers.

Between 1946 and 1974 the APA review published twenty-four articles by Aberastury on a wide range of subjects: infant psychoanalysis; treatment indications; applied psychoanalysis; the creation of a diagnostic test, “El constructor infantil,” based on a construction game familiar to children in Argentina; clinical cases; transference; music; technique; philosophy; language; unconscious fantasies; supervision; etc. A year after her death by suicide, a chronological list of her 145 published works appeared in the APA review (no. 3/4, 1973). Aberastury also published articles in the reviews of associations in Uruguay, Brazil, and France, as well as in *The International Journal of Psycho-Analysis* and, in Argentina, in reviews of child and adolescent psychiatry and psychology.

EDUARDO J. SALAS

See also: Argentina; Brazil; Pichon-Rivière, Enrique.

### Bibliography

Aberastury, Arminda. (1959). Una experiencia psicodramática con niños. In E. J. Salas, G. Smolensky, L. Grinberg,

M. Langer, and E. Rodrigue (eds.), *El grupo psicológico*. Buenos Aires: Nova, APA, 1959.

———. (1978). *La paternidad*, Buenos Aires: Kargieman, 2nd ed., 1985; A. Aberastury, E. J. Salas, *A paternidade: Um enfoque psicanalítico*.

Aberastury, Arminda, Aberastury, Marcelo, and Cesio, Fidas. (1967). *Historia enseñanza y ejercicio legal del psicoanálisis*. Buenos Aires: Bibliografica Omeba.

---

## ABRAHAM, KARL (1877–1925)

Karl Abraham, a German psychoanalyst and doctor, was born May 3, 1877, and died December 25, 1925, in Berlin. The son of Nathan Abraham, a businessman, and Ida Oppenheim, he was the youngest of two sons in an Orthodox Jewish family. After studying medicine in Würzburg, Berlin, and Freiburg-im-Breisgau, he married his cousin Hedwig Bürgner in 1906. They had two children; his daughter was the well-known psychoanalyst Hilda Abraham.

Abraham began his training in psychiatry in Berlin, then in Zurich with Eugen Bleuler, where the physician-in-chief was Carl Gustav Jung. It was here that he became familiar with Freud’s writings. In 1907 he opened an office in Berlin and, in 1910, founded the Berlin Institute of Psychoanalysis. From 1914 to 1918 he was mobilized as chief physician in a psychiatric unit. It was during this time that he grew interested in studying war neuroses. He was president of the International Psychoanalytic Association (IPA) from 1918 to 1925.

A student and friend of Freud, he was a member of the secret “Committee” from its inception. In 1918, he received an award in recognition of his work in analysis. Co-editor of the *Jahrbuch für Psychoanalyse*, *Internationale Zeitschrift für Psychoanalyse*, and *Zentralblatt für Psychoanalyse*, he was the analyst and teacher of Felix Boehm, Helene Deutsch, Edward and James Glover, Karen Horney, Melanie Klein, Carl Müller-Braunschweig, Sándor Radó, Theodor Reik, and Ernst Simmel.

In addition to his research on collective psychology (“Dreams and Myths,” 1909/1949), Abraham made important original contributions to the study of the development of the libido, including *Versuch einer Entwicklungsgeschichte der Libido auf Grund der Psychoanalyse seelischer Störungen* (1924) (*A Short Study of the Development of the Libido Viewed in the Light of*



*Mental Disorders*, 1929). Abraham's starting point was Freud's theory of the stages of pregenital organization (1916–1917). He introduced a differentiation in the phase of libido development designated by Freud as oral-cannibalistic by proposing the existence of two aspects of oral activity—sucking and biting. Based on this hypothesis, he inferred two different modes of infantile object relation, incorporation by sucking and destruction by biting. This last relation was said to introduce the conflict of ambivalence into the infant's life. Starting with this conflict, Abraham interpreted the ego disturbances of the melancholic adult: the ambivalence of the instinctual life causes a withdrawal of libidinal cathexis from the object; the liberated libido then turns toward the ego, which introjects the object. Abraham links the psychogenesis of melancholy with the disappointing mother during the early infantile phase of libido development. If it occurs before the successful mastery of oedipal wishes, that is, during the phase preceding the triumph of the narcissistic stage, then an associative link is made between the Oedipus complex and the cannibalistic stage of libido development. This would make possible the consecutive introjection of the two love objects, the father and mother.

Even before Abraham had begun to study manic-depressive psychosis (from 1916 to 1924), he had made an important discovery in the research on schizophrenia in *Die psychosexuelle Differenz der Hysterie und der Dementia Praecox* (1908) (*Psychosexual Differences between Hysteria and Dementia Praecox*, 1949): Disturbances of ego functions are secondary with respect to the disturbances in the libidinal area. Thus Abraham could make use of libido theory to understand dementia praecox. In this same work Abraham introduced the concept of “autism,” which was later taken up by Eugen Bleuler (1911).

Abraham is one of the founders of psychoanalytic research on psychoses, on collective psychoanalytic psychology and, with Sándor Ferenczi and Ernst Simmel, on the psychoanalysis of war neuroses. His principal work, “Examination of the Earliest Pregenital Stage of Libido Development,” has continued to stimulate research in the field down to the present day. The Psychoanalytic Training Institute he created in Berlin has become a model for other institutes throughout the world and the current Institute of Psychoanalysis in Berlin bears his name. Abraham published five books and 115 articles and made numerous presentations at

IPA congresses. His complete works have been collected and translated into several languages.

JOHANNES CREMERIUS

*Work discussed:* “Dreams and Myths.”

*See also:* Depression; Germany; Libidinal stage; Libido; Mania; Melancholia; Visual and psychoanalysis; Secret Committee; Work of mourning.

### **Bibliography**

Abraham, Karl. (1949). Dreams and myths: A study in race psychology. In *Selected papers of Karl Abraham, M.D.* (Douglas Bryan and Alix Strachey, Trans.). London: Hogarth Press and the Institute of Psycho-Analysis. (Original work published 1909)

———. (1949). A short study of the development of the libido viewed in the light of mental disorders. In *Selected papers of Karl Abraham, M.D.* (Douglas Bryan and Alix Strachey, Trans.). London: Hogarth Press and the Institute of Psycho-Analysis. (Original work published 1924)

Cremerius, Johannes. (1969–1971). *Karl Abraham: psychoanalytische Studien*. Frankfurt am Main: S. Fischer.

Freud, Sigmund. (1926). Karl Abraham. *SE*, 20: 277–278.

Grinstein, Alexander. (1968). *On Sigmund Freud's dreams*. Detroit: Wayne State University Press.

---

## **ABRAHAM, NICOLAS (1919–1975)**

Nicolas Abraham, a psychoanalyst and philosopher, was born on May 23, 1919, in Kecskemet, Hungary, and died on December 18, 1975, in Paris. He came from an educated family, and his father was a rabbi and printer. After spending his childhood in Hungary, he studied philosophy in Paris. He worked in the Department of Aesthetics of the Centre National de la Recherche Scientifique (French National Center for Scientific Research) during the 1940s and 1950s and was trained in analysis at the Psychoanalytic Society of Paris. He worked closely with Maria Torok, who continued their research activity after Abraham's death.

Between 1959 and 1975 Abraham's work contributed to the renewal of psychoanalytic theory and practice. Together with Maria Torok he introduced several key concepts of contemporary psychoanalysis: the family secret, transmitted from one generation to the next (theory of the phantom), the impossibility of mourning following the emergence of shameful libidinal impulses

in the bereaved before or after the death of someone (mourning disorder), secret identification with another (incorporation), the burial of an inadmissible experience (crypt). In *The Wolf Man's Magic Word* (1986) and *The Shell and the Kernel* (1994), Nicolas Abraham explored the ravages of trauma and the other enemies of life, and his discoveries flesh out Freud's theories and help expand the limits of analysis.

Abraham's clinical experience forced him to modify some of the fundamental assumptions of Freudian theory (oedipal fantasies, the castration complex, the death impulse) and isolate hitherto unknown sources of human suffering. The principle of trauma that emerges, trauma that arrests spontaneous self-creation (or introjection in the sense defined by Sándor Ferenczi in 1909 and 1912), constitutes the fulcrum around which these discoveries were organized. Abraham also redirected the focus of classic psychoanalysis, centered on libidinal conflicts, to the possibility of psychic development and discovery that can be realized at any age, as well as to the obstacles to such development encountered in catastrophes such as social shame, war, mourning, racial or political persecution, hate crimes, and concentration camps.

In France, Abraham's work constituted a third way between orthodox Freudianism and Lacanianism. Overcoming various forms of resistance, it has achieved worldwide recognition and has been translated into English, German, and Italian; translations into Swedish, Hungarian, and other languages are currently underway. His influence can be found in the growing interest of contemporary psychoanalysis in the transgenerational point of view and in the analysis of the singular traumas of the individual within the family environment.

NICHOLAS RAND AND MARIA TOROK

See also: Introjection; Phantom; Torok, Maria; Secret.

### Bibliography

Abraham, Nicolas, and Torok, Maria. (1986). *The Wolf Man's magic word* (Nicholas Rand, Trans.). Minneapolis: University of Minnesota Press. (Original work published 1976)

———. (1994). *The shell and the kernel: Renewals of psychoanalysis* (Nicholas Rand, Trans.). Chicago: University of Chicago Press. (Original work published 1978)

Ferenczi, Sandor. (1968). Transfert et introjection. *O.C., Psychoanalyse I* (Vol. I : 1908-1912, pp. 93–125). Paris: Payot. (Original work published 1909)

———. (1968). Le concept d'introjection. *O.C., Psychoanalyse I* (Vol. I : 1908-1912, pp. 196–198). Paris: Payot. (Original work published 1912)

Rand, Nicholas, and Torok, Maria. (1995). *Questions à Freud: du devenir de la psychanalyse*. Paris: Les Belles Lettres.

## ABSTINENCE/RULE OF ABSTINENCE

The term “abstinence/rule of abstinence” designates a number of technical recommendations that Freud stated regarding the general framework of the psychoanalytic treatment. As is the case with the fundamental rule, these recommendations have two symmetrical sides, that of the patient and that of the analyst.

The problems posed when acting out takes the place of remembering led Freud to recommend, “One best protects the patient from injuries brought about through carrying out one of his impulses by making him promise not to take any important decisions affecting his life during the time of his treatment—for instance not to choose any profession or definitive love-object—but to postpone all such plans until after his recovery. At the same time one willingly leaves untouched as much of the patient's personal freedom as is compatible with these restrictions, nor does one hinder him from carrying out unimportant intentions, even if they are foolish” (Freud 1914g, p. 153). This advice to abstain from all important decisions was, for a long time, stated at the beginning of each treatment, even while reflections on the place and function of “acts” in the course of a treatment, both within and outside the analytic situation, continued to stimulate much theoretical and practical debate.

Freud described the need for the analyst to observe abstinence in his article “Observations on Transference-Love”: “I have already let it be understood that analytic technique requires of the physician that he should deny to the patient who is craving for love the satisfaction she demands. The treatment must be carried out in abstinence. By this I do not mean physical abstinence alone, nor yet the deprivation of everything that the patient desires, for perhaps no sick person could tolerate this. Instead, I shall state it as a fundamental principle that the patient's need and longing should be allowed to persist in her, in order that they may serve as forces impelling her to do work and to make changes” (Freud 1915a, pp. 164–165).

Thus it is after years of psychoanalytic practice that the notion of abstinence appeared as such in Freud's work. The theory of unconscious desire and of the transference had to be elaborated and their application to the progression of the treatment put to the test in order for their technical consequences to be recognized. The transferential demands and the counter-transferential responses that Freud's followers made him become aware of, such as the case of Jung and Sabina Spielrein, as well as what he then learned about the practice of "wild analysis," quickly persuaded him to enunciate a recommendation. His followers subsequently and little by little transformed the recommendation into a "principle," and then a "rule," which became quite rigid.

It is clear that, from the beginning, it was never a matter of moral prescription, but a technical one that accorded with the metapsychological demands, particularly the economic ones, involved in the psychoanalytic situation. In the twenties, when Freud and then Sándor Ferenczi experimented with the "active technique," frustration (*Versagung*) resulting from interdictions or injunctions that, it was hoped, would turn the patient away from modes of satisfaction judged to be pathological. In 1918, Freud wrote, "By abstinence, however, is not to be understood doing without any and every satisfaction—that would of course not be practicable; nor do we mean what it popularly connotes, refraining from sexual intercourse; it means something else which has far more to do with the dynamics of falling ill and recovering. You will remember that it was a *frustration* that made the patient ill, and that his symptoms serve him as substitutive satisfactions. [...] Cruel though it may sound, we must see to it that the patient's suffering, to a degree that is in some way or other effective, does not come to an end prematurely." (Freud 1919a [1918], pp. 162–163) And Ferenczi continued, "[...] the 'active therapy,' hitherto regarded as a single entity, breaks up into the systematic issuing and carrying out of *injunctions* and of *prohibitions*, Freud's 'attitude of abstinence' being constantly maintained" (Ferenczi, pp. 193–194). It is in this sense, then, that Rudolph Lowenstein—and also Anna Freud—explained that while some analysts think it necessary to prohibit their patients from performing this or that perverse sexual practice, it would not be wise to recommend the same to homosexual patients (Lowenstein).

It was chiefly in the United States that a slippage took place that turned the recommendation of

abstinence into an increasingly restrictive "rule." Karl Menninger and Phillip Holzman (1973) even considered it the "second fundamental rule" of psychoanalysis. But the risk of insinuating a moral judgment left a lingering ambiguity, and proponents of relaxing the rule argued that some analysts used it to prohibit their patients from having sexual relations or extramarital affairs.

Over the years, the notion of abstinence came to be invoked less and less, and it has even been proposed that analysts speak instead of a "rule of the reality principle." Above all, it has been replaced by "neutrality," a concept not explicitly mentioned by Freud (Mijolla), and even a "benevolent neutrality" (Stone, 1961) or a "compassionate neutrality" (Greenson; Weigert 1970). In the evolution of these attitudes, the mark of Sándor Ferenczi's important influence on matters of practice is obvious, since the prescriptions of abstinence pushed to the extreme were those of the "active technique" and since the frequent tendency of "benevolent neutrality" to drift towards more and more established "benevolence" of the maternal type characterized the last years of his practice.

ALAIN DE MIJOLLA

*See also:* Act, passage to the; Benevolent neutrality; Frustration; Neutrality; Technique with adults, psychoanalytic; Transference love.

### **Bibliography**

- Ferenczi, Sándor. (1921) The further development of the "active technique" in psychoanalysis. In *Selected Writings*. London: Penguin, 1999: 187–204.
- Freud, Sigmund. (1919a [1918]). Lines of advance in psycho-analytic therapy. *SE*, 17: 157–168.
- . (1915a [1914]). Observations on transference love (further recommendations on the technique of psychoanalysis III). *SE*, 12: 157–171.
- Greenson, Ralph R. (1958). Variations in classical psychoanalytic technique. *International Journal of Psycho-Analysis*, 29, 200–201.
- Loewenstein, Rudolph M. (1958). Remarks on some variations in psycho-analytic technique. *International Journal of Psycho-Analysis*, 39, 202–210.
- Mijolla, Alain de. (1998). Le "conflit thérapeutique" et la "neutralité." In G. Diatkine and J. Schaeffer (Eds.), *Psychothérapies psychanalytiques* (pp. 110–119). Paris: Presses Universitaires de France.

## ACT/ACTION

The terms “act” and “action” are related, both referring to a form of behavior (motor, verbal, etc.) intended to modify the environment, either to avoid a danger or unpleasure, or to satisfy a need or desire. The term “act,” however, refers primarily to this event in its uniqueness and effectiveness, whereas “action” designates both a process, which can be more or less complex and durable, and the result of that process. These definitions are not psychoanalytic in themselves, and there is no coherent body of thought in psychoanalysis concerning them, in spite of the rather fragmentary references found in Freud and subsequent attempts to give these concepts a theoretical status.

The first psychoanalytic use of the term by Freud is probably his reference to “specific action,” that is, the behavior that results in the satisfaction of a need (Manuscript E, 1894, and “Project for a Scientific Psychology,” 1895, in 1950a). This idea, which he returned to only intermittently, may seem narrowly behaviorist. However, even in these early works, Freud gives the term an entirely different dimension. He writes that since the infant is incapable of satisfying its own needs, “specific action” by another person is needed, and he elaborates on what he considers essential to the process: “If the satisfaction of the need is not satisfied in this way, it is manifested as desire through hallucinatory satisfaction. But the impossibility of maintaining this hallucinatory satisfaction in the face of the persistence of the need gives rise to the representation; the object is born, within the movement of desire, from its presence-absence.” A preliminary version of these ideas is found in the following comment by Freud that appears in the “Project”: “The initial helplessness of human beings is the primal source of all moral motives.”

Freud would return to and develop these ideas in his “Formulations on the Two Principles of Mental Functioning” (1911b), where he attempts to show that, whenever the reality principle gets the upper hand of the pleasure principle, “motor discharge was now employed in the appropriate alternation of reality; it was converted into *action*. Restraint upon motor discharge (upon action) which then became necessary, was provided by means of the process of *thinking*, which was developed from the presentation of ideas” (1911b, p. 221).

This idea, whereby thought is a suspension of adaptive perceptual-motor activity, a “trial activity” involving representations, was in fact familiar to a number of

authors at the beginning of the twentieth century, as has been shown by Henri Wallon (1942). It was discussed at greater length by Freud in the last part of *Totem and Taboo* (1912–13a), which he concludes with this quote from Goethe: “In the beginning was the deed.”

Although the topic was not fully developed by Freud, the terms “act” and “action” appear frequently in his writings, whether he is discussing failed acts, compulsive acts, symptoms, repetitive acts (1914g), the suspension of motor activity during dreams, etc. The prohibition against action within the analytic situation stimulated, both during Freud’s lifetime and after, a number of reflections on the infractions constituted by *actings*.

Since Freud’s day, there have been many attempts to understand these issues. Heinz Kohut advanced the concept of “action-thought,” a concrete thought process halfway between action and thought. Roy Schafer (1976) attempted to refine metapsychology in terms of the actions that constituted thought acts. Daniel Widlöcher (1986) attempted to reformulate it in terms of “unconscious presentations of actions” that generate thought actions.

Throughout these approaches the reference to impulse is vague or explicitly eliminated. However, there are no benefits to this. To understand the problem of action and its relationship with mental activity, we must take account of representation and fantasy. If “in the beginning was the deed,” (from Goethe’s *Faust*, part I, scene 3, quoted by Freud in 1912–13a, p. 161) this indeed involves understanding the development and functioning of psychic activity within two closely related points of view: representations and symbolization processes that terminate in secondary thought, and the organization of fantasy, where fantasies can be considered to be “representations of actions” (Perron-Borelli, 1997; Perron-Borelli, and Perron, 1997).

ROGER PERRON

*See also:* Acting out/acting in; Action-thought (H. Kohut); Reality principle; Specific action; *Totem and Taboo*.

### Bibliography

- Perron-Borelli, Michèle. (1997). *Dynamique du fantasme*. Paris: Presses Universitaires de France.
- Perron-Borelli, Michèle, and Perron, Roger. (1997). *Fantasme, action, pensée*. Alger: Éditions de la Société algérienne de psychologie.

- Schafer, Roy. (1976). *A new language for psychoanalysis*. New Haven, CT: Yale University Press.
- Wallon, Henri. (1970). *De l'acte à la pensée*. Paris: Flammarion. (Original work published 1942)
- Widlöcher, Daniel. (1986). *Métapsychologie du sens*. Paris: Presses Universitaires de France.

### Further Reading

- Ellman, J., rep. (2000). Panel: The mechanism of action of psychoanalytic treatment. *Journal of the American Psychoanalytic Association*, 48, 919–928.
- Grand, Stanley. (2002). Action in the psychoa situation: internal & external reality. *Psychoanalytic Psychology*, 19, 254–280.
- Katz, Gil. (1998). Where the action is: the enacted dimension of analytic process., *Journal of the American Psychoanalytic Association*, 46, 1129–1168.
- Ogden, Thomas H. (1994). The concept of interpretive action. *Psychoanalytic Quarterly*, 63, 219–245.

## ACTING OUT/ACTING IN

The term “acting out” corresponds to Freud’s use of the German word “agieren” (as a verb and as a noun). It should be distinguished from the closely related concept of “passage à l’acte,” inherited from the French psychiatric tradition and denoting the impulsive and usually violent acts often addressed in criminology.

“Acting out” refers to the discharge by means of action, rather than by means of verbalization, of conflicted mental content. Though there is this contrast between act and word, both sorts of discharge are responses to a return of the repressed: repeated in the case of actions, remembered in the case of words. Another distinction occasionally drawn is between acting out and acting in, used to distinguish between actions that occur outside psychoanalytic treatment (often to be explained as compensation for frustration brought on by the analytic situation, by the rule of abstinence, for example) and actions that occur within treatment (in the form of nonverbal communication or body language, but also of prolonged silences, repeated pauses, or attempts to seduce or attack the analyst).

Freud first mentioned acting out in connection with the case of “Dora” (1905e [1901]), noting with

respect to her transference that his patient took revenge on him just as she wanted to take revenge on Herr K.: Dora “deserted me as she believed herself to have been deceived and deserted by him. Thus she acted out an essential part of her recollections and phantasies instead of reproducing them in the treatment” (p. 119).

The notion of acting out is closely bound up with the theory of the transference and its development. Though Freud treated the transference as the cause of acting out—and as an obstacle to treatment—in the Dora case, he subsequently described transference as a great boon to analysis, provided it could be successfully recognized and its significance conveyed to the patient. Acting out is thus attributable to a failure of the interpretive work or to the patient’s failure to assimilate it. In his paper “Remembering, Repeating, and Working-Through” (1914g), Freud revisited the distinction between remembering and acting out: “The patient does not *remember* anything of what he has forgotten and repressed, but *acts* it out. He reproduces it not as a memory, but as an action; he *repeats* it, without, of course, knowing that he is repeating it” (p. 150). The examples that Freud gave here involved the repetition of feelings (feeling rebellious and defiant, or “helpless and hopeless”) that had formerly been directed at a person or situation in childhood but that now manifested themselves, either directly or indirectly (through dreams, silences, and so on), vis-à-vis the analyst. Freud’s assessment of such instances of acting out was nuanced, for he realized that they were at once a form of resistance against the emergence of a memory and a particular “way of remembering” (p. 150).

Inasmuch as acting out occurs outside as well as inside the analytic situation, Freud went on, “We must be prepared to find, therefore, that the patient yields to the compulsion to repeat, which now replaces the impulsion to remember, not only in his personal attitude to his doctor but also in every other activity and relationship which may occupy his life at the time—if, for instance, he falls in love or undertakes a task or starts an enterprise during the treatment” (p. 151). Acting out and repeating are ultimately the same process, involving “everything that has already made its way from the sources of the repressed into [the patient’s] manifest personality—his inhibitions and unserviceable attitudes and his pathological characteristics” (p. 151).

All the same, acting out in reality could have grave consequences, precipitating disasters in the patient's life and dashing any hope of cure through psychoanalysis. It is thus up to the analyst, relying on the patient's transference-based attachment, to control the patient's impulses and repetitive acts, notably by extracting a promise to refrain, while under treatment, from making any serious decisions regarding professional or love life. The analyst, however, must be "prepared for a perpetual struggle with his patient to keep in the psychical sphere all the impulses which the patient would like to direct into the motor sphere; and he celebrates it as a triumph for the treatment if he can bring it about that something that the patient wishes to discharge in action is disposed of through the work of remembering" (p. 153).

In Freud's thinking, then, acting out was long associated with the transference. In *An Outline of Psycho-Analysis* (1940a [1938]) Freud emphasized the need to clearly demarcate between "actualization" in the transference from acting out, whether inside or outside the analytic session: "We think it most undesirable if the patient *acts* outside the transference instead of remembering. The ideal conduct for our purposes would be that he should behave as normally as possible outside the treatment and express his abnormal reactions only in the transference" (p. 177).

Many other authors have deployed the notion of acting out, typically when considering personalities more inclined to act out than to remember in the context of the transference. Thus Anna Freud (1968) saw pre-oedipal pathologies in this light, and León Grinberg hypothesized that acting out is a reaction to inadequate mourning for the loss of an early object. Such approaches take acting out to be inappropriate or even disruptive acts precipitated by the pressure of unconscious wishes.

SOPHIE DE MIJOLLA-MELLOR

*See also:* Abstinence/rule of abstinence; Active technique; Act, passage to the; "Fragment of an Analysis of a Case of Hysteria" (Dora, Ida Bauer); Technique with adults, psychoanalytic.

### **Bibliography**

- Freud, Anna. (1968). "Acting out." *International Journal of Psycho-Analysis*, 49 (2–3), 165–170.
- Freud, Sigmund. (1905e [1901]). "Fragment of an analysis of a case of hysteria." *SE*, 7: 1–122.

———. (1914g). "Remembering, repeating, and working-through (further recommendations on the technique of psycho-analysis II)." *SE*, 12: 145–156.

———. (1940a [1938]). An outline of psycho-analysis. *SE*, 23: 139–207.

Grinberg, León. (1968). "On acting out and its role in the psychoanalytic process." *International Journal of Psycho-Analysis*, 49, 171–178.

### **Further Reading**

Chasseguet-Smirgel, Janine. (1990). On acting out. *International Journal of Psychoanalysis*, 71, 77–86.

Eagle, Morris. (1993). Enactments, transference, and symptomatic cure: a case history. *Psychoanalytic Dialogues*, 3, 93–110.

De Blecourt, Abraham. (1993). Transference, countertransference, and acting out in analysis. *International Journal of Psychoanalysis*, 74, 757–774

Gill, Merton M., disc. (1993). On "Enactments": Interaction and interpretation. *Psychoanalytic Dialogues*, 3, 111–122.

Goldberg, Arnold. (2002). Enactment as understanding and misunderstanding. *Journal of the American Psychoanalytic Association*, 50, 869–884.

Paniagua, Cecilio. (1998). Acting in revisited. *International Journal of Psychoanalysis*, 79, 499–512.

Roughton, Ralph E. (1993). Useful aspects acting out: repetition, enactment, actualization. *Journal of the American Psychoanalytic Association*, 41, 443–472.

---

## **ACTION-LANGUAGE**

The notion of "action-language" was proposed by Roy Schafer to refer to a code or group of rules, within the framework of a conceptualization that aims to legitimize existence to all conscious or unconscious activity, and all mental acts capable of being externalized by means of words or gestures, so that these mental acts can be related to unconscious conflicts (slips of the tongue, parapraxes), representations of self and object, bodily fantasies, feelings and emotions, desires and beliefs, or courses of action that the subject uses to "put aside" certain ideas or invest others.

Action-language involves a strategy (favoring the use of action verbs and adverbs over nouns, adjectives,

and the verbs *have* and *be*) for listening to, acknowledging, translating, retranslating, interpreting, and organizing the data or the modalities of action of the agent or his or her person, that is, the analysand, within the context of the transference and resistance.

The analysand acts in a conflicted way, whether at the unconscious, preconscious, or conscious level. He or she follows actions of thinking or ideas that possess mental qualities, and verbalizes according to different narrative registers. According to Schafer, the concept's originator, who drew his inspiration from the works of Ludwig Wittgenstein and Jean-Paul Sartre, action-language is an alternative to the traditional, mechanistic terminology of metapsychology, encumbered by psychoeconomic, spatial, biological, physiochemical, or anthropomorphic metaphors. Such metaphors, according to Schafer, are devoid of content, anachronistic, attributive and conducive to fragmentation, archaic and childish. Terms such as *motives*, *propulsive energy forces*, *regulating principles*, *structures*, *functions*, *instincts*, and *objects*, used by Sigmund Freud and psychoanalysts in a general way, can only very partially account for the mind's activities of ideation and speech (including inner thoughts, associations, and substitutive formations).

By contrast, action-language purports to bring, through the rigorous descriptions of mental acts it entails, greater clarity and effectiveness to treatment, in that the causal explanation based on the concrete and active "existence" of the person ostensibly leads to a personal recharacterization of his or her psychic reality. Further, by getting away from notions of the "mind-machine," action and its language can supposedly bring us back to the true hermeneutics that is psychoanalysis. The idea, moreover, is not to replace or alter psychoanalytic technique, but to find a metalanguage that is faithful to its origins.

A number of charges (psychologism, personalism, phenomenological reductionism, disregard of the unconscious, a flattening of discourse, the inadequacy of the rules of transcription) have been leveled against this undertaking "in the first person," which aims to provide a foundation for psychoanalysis and to oppose any reification of the subject.

SIMONE VALANTIN

*See also:* Act/action; Action-(re)presentation; Interpretation.

### **Bibliography**

- Schafer, Roy. (1976). *A new language for psychoanalysis*. New Haven, CT: Yale University Press.
- . (1978). *Language and insight*. New Haven, CT: Yale University Press.
- . (1980). Action language and the psychology of the self. *Annual of Psychoanalysis* (Chicago Institute). 8, 83–92.

### **Further Reading**

- Spence, Donald P. (1982). Some clinical implications of action language. *Journal of the American Psychoanalytic Association*, 30, 169-184.

---

## **ACTION-(RE)PRESENTATION**

The notion of action-presentation (or action-representation) is based on two Freudian models: on the one hand, the idea that representation derives from the failure of hallucinatory wish-fulfillment, developed in *The Interpretation of Dreams* (1900), and on the other, the model that establishes the unconscious "thing-presentation" as a mental "representative" of the instinct, elaborated in "Repression" (1915d) and "The Unconscious" (1915e). Such a grouping of concepts aims to bring out the dynamic functions of fantasies within the general realm of a theory of representation (Perron-Borelli, 1997).

Action-presentations, which are ubiquitous in dreams because of the hallucinatory process induced by the inhibition of motor discharges, are at the core of fantasmatic organization. Indeed, fantasies cannot be reduced to object-presentations: They originate in a dynamic organization that from the outset brings together intrapsychic processes and, at their most basic level, an action-presentation and an object-presentation.

The action-presentation occupies a central position in the "fundamental structure of fantasy," the product of a later and more complex elaboration, that makes possible the representation of all forms of the subject's desire toward the object. This involves a representational structure, made up of three parts (subject-action-object) and based on an elaboration of the primal scene, which allows all its variants to be represented. This structure thus takes on the role of a system of transformations capable of representing the plurality

and mobility of desires and the identifications (bisexual) that characterize the oedipal organization.

Within the dynamics of this fundamental structure, the action-presentation is the pivot point around which the displacement of objects, as well as the inversion of subject and object positions linked to the related dynamics of drives and identifications (inversion of active/passive or sadistic-masochistic movements, among others), can be effected.

The role played by action-presentations in fantasies sheds light on the dynamic links between fantasies and effective actions (Perron-Borelli 1997; Perron & Perron-Borelli 1987). This allows for a clearer understanding of behaviors enacted during treatment (Freudian *agieren*, or acting out), compulsive behaviors, phobias of impulsive acts, and the like. Such an approach emphasizes the importance of fantasy elaboration inasmuch as it prepares and makes possible fulfillments (satisfactions) through action.

This concept of action-presentations, closely linked to the dynamics of fantasy, can be compared to the idea of “unconscious action-presentation” used by Daniel Widlöcher in *Métapsychologie du sens* (Metapsychology of meaning; 1986). However, this author adopted a very different theoretical framework. Far from seeing the action-representation as being articulated with an underlying drive, he seemed to attempt to erase the very notion of the drive. According to him, the unconscious is made up of a sort of “memory of actions” that can only be grasped through the analytic listening process.

The conceptions of Roy Schafer and Heinz Kohut are even further from the fundamental bases of Freudian metapsychology. In *A New Language for Psychoanalysis* (1976), under the label “action language,” Schafer essentially reduced mental processes as a whole to mental “activities” of representation and speech that are connotable by action verbs. For its part, Kohut’s idea of “action-thought,” put forward in *The Analysis of the Self* (1971), is the expression of a concrete, creative thought in which action and thought are conflated.

ROGER PERRON

*See also:* Act/action; Acting out/acting in; Action-thought (H. Kohut); Fantasy; Thing-presentation; Wish, hallucinatory satisfaction of a.

### **Bibliography**

- Freud, Sigmund. (1900a). The interpretation of dreams. Part I. *SE*, 4: 1–338; The interpretation of dreams. Part II. *SE*, 5: 339–625.
- . (1915d). Repression. *SE*, 14: 141–158.
- . (1915e). The unconscious. *SE*, 14: 159–204.
- Kohut, Heinz. (1971). *The analysis of the self*. New York: International Universities Press.
- Perron, Roger, and Perron-Borelli, Michelle. (1987). Fantasme et action. *Revue française de psychanalyse*, 51 (2), 539–637.
- Perron-Borelli, Michèle. (1997). *Dynamique du fantasme*. Paris: Presses Universitaires de France.
- Schafer, Roy. (1976). *A new language for psychoanalysis*. New Haven: Yale University Press.
- Widlöcher, Daniel. (1986). *Métapsychologie du sens*. Paris: Presses Universitaires de France.

---

### **ACTION-THOUGHT (H. KOHUT)**

*Action-thought* is the expression of a concrete, creative kind of thought merged with action. This category has its origin in pioneering experiments that illustrate a new scientific principle by which psychoanalytic patients reveal insights they are in the process of acquiring. In the psychoanalytic context, action-thought is creative—and thus quite distinct from resistance, from acting out, or from the thinking that replaces memories dismantled by interpretation. The notion is part of the theory of the autonomous development of narcissism, as worked out by Heinz Kohut and his followers.

Action-thought was first considered by Kohut in *The Analysis of the Self* (1971), where he spoke of a kind of sublimation presupposing the modification of archaic narcissistic fantasies. He expanded on the idea of nonreplicable scientific experiments expressing the concrete, creative thought of genius in his later work *The Restoration of the Self* (1977, pp. 36ff; see also Koyré, Alexandre, 1968). The notion advanced was that creation sometimes takes place in such a way that thought and action are indistinguishable, as when scientists believe they have gleaned knowledge from external reality when in fact that knowledge was already a part of their own mental reality. Kohut addressed the clinical relevance of action-thought in a



letter written on May 16, 1974, in which he recounted that a patient prone to concrete thought carried out a meticulous exploration of the analyst's office; this in no way involved an expression of childlike curiosity, but rather of thinking in and through action.

In 1977, when Kohut was proposing a generalized self psychology, action-thought was a crucial concept that clearly set his approach to the treatment of narcissistic patients and its termination apart from that of ego psychology. Returning to the analogy of scientific discovery and advances in knowledge of reality, Kohut alluded to the moment when facts could not yet be distinguished from theory since thought and action were not yet differentiated.

The concept of action-thought was emblematic of Kohut's new theory of narcissism, according to which the patient acted out the stages leading to a new mental equilibrium dependent on a modification in his or her narcissism. In the clinical context, this changed narcissism was the vehicle of messages interpretable by the patient, messages that would not be ignored but could be transformed. This was a sign of progress, for psychoanalytic treatment could not arrive at change by interpretation alone, but called too for a "transmuting internalization" of the narcissistic functions as assumed and verbalized by the analyst (Kohut, 1977, pp. 30–32).

Action-thought was thus cardinal for Kohut, who felt that narcissism was a factor in all creativity, which he understood to be a positive transformation of some aspect of the individual's narcissism. The repair of narcissism—the essential goal in the psychoanalysis of narcissistic personalities—tended to be seen as the universal road to therapy. And neurosis itself, Kohut felt, was at risk of being reduced to narcissistic weaknesses left over from the oedipal period.

AGNÈS OPPENHEIMER

See also: Kohut, Heinz; Narcissism; Self-analysis

### **Bibliography**

Kohut, Heinz. (1971). *The analysis of the self*. New York: International Universities Press.

———. (1977). *The restoration of the self*. New York: International Universities Press.

Koyré, Alexandre (1968). *Metaphysics and measurement: Essays in scientific revolution*. Cambridge, MA: Harvard University Press.

## **ACTIVE IMAGINATION (ANALYTICAL PSYCHOLOGY)**

Active imagination in Carl Jung's analytical method of psychotherapy involves opening oneself to the unconscious and giving free rein to fantasy, while at the same time maintaining an active, attentive, conscious point of view. The process leads to a synthesis that contains both perspectives, but in a new and surprising way.

"The Transcendent Function" (1916b [1958]) is Jung's first paper about the method he later came to call active imagination. It has two parts or stages: *Letting the unconscious come up* and *Coming to terms with the unconscious*. He describes its starting points (mainly moods, images, bodily sensations); and some of its many expressive forms (painting, sculpting, drawing, writing, dancing, weaving, dramatic enactment, inner visions, inner dialogues). In this early essay he links his method to work with dreams and the therapeutic relationship. The term "transcendent function" encompasses both the method and its inborn dynamic function that unites opposite position in the psyche.

Jung discovered active imagination out of his own need for self-healing in a certain period of his life. It all began with symbolic play: "I had no choice but to...take up that child's life with his childish games" (Jung, 1962/1966, p. 174). He found that as long as he managed to translate his emotions into symbolic images, he was inwardly calmed and reassured. When he opened to the raw material of the unconscious, he did not identify with the affects and images, rather, he turned his curiosity toward the inner world of the imagination. This led to a deep process of renewal, as well as insights that gave him a new orientation. In the years that followed, he recommended it to many of his patients and students. He presents active imagination as an adjunctive technique, but by linking it to his symbolic method of dream interpretation and work with the analytic relationship, Jung laid the groundwork for a comprehensive method of psychotherapy.

Active imagination is a direct extension of Freud's free association (Jung, 1929, p. 47). Other related notions include the transcendent function; the natural healing function of play and imagination; Sandplay; active vs. passive attitudes toward fantasy; reductive and constructive ways to understand the unconscious content; creative formulation vs. understanding; liberation from the analyst (Chodorow, 1997).

Jungian analysts hold a wide range of views on active imagination (Samuels, 1985). For some it is a peripheral technique not much used anymore. For others it is the essence and goal of analysis.

JOAN CHODOROW

*See also:* Amplification (analytical psychology); Analytical psychology.

### **Bibliography**

- Chodorow, Joan. (1997). Introduction. *Jung on active imagination* (pp. 1–20). London: Routledge.
- Jung, Carl Gustav. (1916b [1958]). The Transcendent Function. *Coll. Works* (Vol. VIII). London: Routledge & Kegan Paul.
- . (1929–31). Freud and Jung: Contrasts. *Coll. Works* (Vol. IV). London: Routledge & Kegan Paul.
- . (1966). *Memories, dreams, reflections*. London: Routledge. (Original work published 1962)
- Samuels, Andrew. (1985). *Jung and the Post-Jungians*. London-Boston: Routledge.

---

## **ACTIVE TECHNIQUE**

A method advocated by Sándor Ferenczi starting in 1919, the active technique consisted of formulating to the patient, at certain moments of stagnation in the treatment, injunctions or interdictions concerning his or her behavior in such a way as to provoke tensions within the psychic apparatus, with the aim of reactivating the process and of bringing to light repressed material.

Only the patient was encouraged to perform certain actions. The psychoanalyst remained inactive and attentive to the emergence of new mnemonic material in the associations of the patient. The process was used only as an “adjuvant” in order to precipitate the emergence of new associations, the interpretation of which remained, just as in the classic technique, the principle task of the analysis.

Impasses with the active technique led Ferenczi, several years later, to abandon an economic and authoritarian conception of psychoanalytic treatment and replace it with neocathartic relaxation and technical elasticity, an approach facilitated by empathy and benevolence.

“We owe the prototype of this ‘active technique’ to Freud himself,” wrote Ferenczi in 1919 (p. 157), noting that at the beginning of the Freud’s work, the cathartic method was a technique of great “activity,” as much on the analyst’s part as the patient’s. The idea in those days was to apply pressure as a way of awakening memories and precipitating the abreaction of blocked affects. This approach was succeeded by the technique of free association, a non-directive method founded on the apparently passive listening and receptivity of the analyst.

However, recalled Ferenczi, it was while developing analytic technique that Freud was led, during the analysis of anxiety hysterics, to require of his patients that they directly confront the critical situations that gave rise to their anxieties, not in order to habituate themselves to those situations, but rather to achieve the “ligature of customary, unconscious paths of discharge of excitation and the enforcement of the preconscious cathexis as well as the conscious ones of the repressed material.” (p. 157)

Thus Ferenczi was led, following Freud, to break at certain points in the treatment with the receptive and passive attitude of the analyst monitoring the associative material of patients, and to intervene actively at the level of their psyche.

“The patients, in spite of close compliance with the ‘fundamental rule’ and in spite of a deep insight into their unconscious complexes, could not get beyond ‘dead ends’ in the analysis until they were compelled to venture out from the retreat of their phobia, and to expose themselves experimentally to the situation they had avoided with anxiety, but, in exposing themselves to this affect, they at the same time overcame the resistance to hitherto repressed material which now became accessible to analysis in the form of ideas and reminiscences” (Ferenczi, 1921/1999, p. 189).

“I really meant,” Ferenczi continues, “that the description of ‘active technique’ should be applied to this procedure, which does not so much represent an active interference on the part of the doctor as on the part of the patient upon whom are imposed certain *tasks* besides the keeping to the fundamental rule. In the cases of phobia the task consisted in the *carrying out of unpleasant activities*.” (p. 189)

Thus “[i]n stimulating what is inhibited, and inhibiting what is uninhibited” (p. 201), in demanding that patients renounce certain satisfactions and in advising

them to perform certain unpleasant acts, Ferenczi hoped to provoke an increase in psychic tension, a new distribution within the libidinal economy, and thus to allow new mnemonic material to become accessible, and ultimately to accelerate the course of the analysis.

For Freud, then, the active technique was a kind of “agent provocateur,” the injunctions and the prohibitions serving only as an adjuvant, promoting the repetition that must then be interpreted or reconstructed in memory.

Later, Ferenczi came to have serious reservations about the usefulness of the active technique. Badly applied, or poorly employed by novice analysts, this method risked exacerbating the patient’s resistances and hampering the deployment of the transference. It was liable to reinforce the patient’s masochism by organizing his or her submission (Bokanowski, T. 1994). Ferenczi specifically questioned the wisdom of an arbitrarily decided date for the termination of the treatment.

So Ferenczi progressively distanced himself, above all in his critical study, “Contra-Indications to the ‘Active’ Psychoanalytical Technique” (1926/1999), from an authoritarian orientation of the treatment founded on frustration and abstinences. He introduced the new notions of “elasticity,” that is, patience and empathy, and “relaxation.” He even mentioned (1933/1999) the aggressive features of the active technique that aimed at a “forced relaxation” in the patient (p. 296).

It was no longer up to the analyst, but rather to the patient, to determine the opportune moment when the treatment had sufficiently progressed to allow him or her to tackle the renunciation of neurotic satisfactions and the overcoming of inhibitions.

In “Analysis, Terminable and Interminable” (1937c), Freud criticized in the firmest manner any intervention of the psychoanalyst at the level of material reality for the purposes of moving the analysis along or of making a negative transference appear artificially when it was not yet manifest.

JEAN-FRANÇOIS RABAIN

*See also:* Abstinence/rule of abstinence; Character neurosis; Direct analysis; Elasticity; Framework of the psychoanalytic treatment; “From the History of an Infantile Neurosis” (Wolf Man); Kovács-Prosznitz, Vilma; Mutual analysis; Sokolnicka-Kutner, Eugénie; Tact; Technique with adults, psychoanalytic; Termination of treatment.

## Bibliography

- Bokanowski, Thierry. (1994). *Ensuite survient un trouble*. In Michèle Bertrand (Ed), *Collectif: Ferenczi, patient et psychanalyste*. Paris: L’Harmattan.
- Ferenczi, Sándor. (1994). Contra-indications to the “active” psycho-analytical technique. In *Further contributions to the theory and technique of psycho-analysis* (pp. 217–230). London: Karnac. (Original work published 1926)
- . (1999). The confusion of tongues between adults and the child (The language of tenderness and of passion). In *Selected writings*. (pp. 255–268). London: Penguin. (Original work published 1933)
- . (1999). The elasticity of psychoanalytic technique. In *Selected writings* (pp. 255–268). London: Penguin. (Original work published 1928)
- . (1999). The further development of the “active technique” in psychoanalysis. In *Selected writings* (pp. 187–204). London: Penguin. (Original work published 1921)
- . (1999). On forced fantasies. In *Selected writings* (pp. 222–230). London: Penguin. (Original work published 1924)
- . (1999). Technical difficulties in a case of hysteria. In *Selected writings* (pp. 151–158). London: Penguin. (Original work published 1919)

## ACTIVITY/PASSIVITY

The terms “activity” and “passivity” were already in use before Freud. For example, Richard von Krafft-Ebbing used them to compare sadism and masochism. Freud initially employed the terms within the framework of the theory of psychosexuality and, more specifically, with respect to the drives, creating paired opposites associated with masculine/feminine. He then used these terms in his dynamic analysis of ego as agency.

For both paired opposites, “Instincts and Their Vicissitudes” (Freud, 1915c) is a key reference. In it Freud referred to activity/passivity as one of “three polarities” that govern “our mental life as a whole” (p. 133), along with the pairs ego/outside world and pleasure/unpleasure. But even in 1896 Freud had already evoked the polarity of activity/passivity in his theory of seduction, which he based on clinical findings and individual histories of neuroses. Hysteria, he wrote at the time, results from “sexual passivity during the pre-sexual period” (1896b, p. 163) that is reacted to by indifference, contempt, or fear. In contrast, in obsessional neurosis,

(*Zwangsneurose*) pleasure is active: the seduced infant actively, aggressively, repeats an experienced sexual attack on another infant. This alteration of the sexual attack experienced by the child from passive to active can also occur in masturbatory activity.

Freud subsequently modified his views by acknowledging a “spontaneous” infantile sexuality not forcibly induced by an adult seducer. This was the theme of his *Three Essays on the Theory of Sexuality* (1905d). In this work Freud described libidinal development as proceeding from “a number of separate instincts and erotogenic zones, which, independently of one another, have pursued a certain sort of pleasure as their sole sexual aim” (p. 207) and have gradually unified under genital sexuality, which becomes primary. Therefore, the “opposition found in all sexual life clearly manifests itself” within a development stage, whether it be the second pregenital or anal-sadistic phase. This is an opposition not between masculine and feminine but between active and passive. Freud noted, “The *activity* is put into operation by the instinct for mastery through the agency of the somatic musculature; the organ which, more than any other, represents the *passive* sexual aim is the erotogenic mucous membrane of the anus” (p. 198). This association comes into play during the anal sadistic phase, since, for Freud, earlier sexual activity, that of oral, or “cannibalistic,” organization, does not yet display these “opposing currents.”

Primarily within a clinical framework Freud noted the opposition of active and passive with respect to homosexuality as well as the opposites sadism/masochism and voyeurism/exhibitionism. He wrote that sexual intent “manifests itself in a dualistic form: active and passive.” A 1915 addition to the *Three Essays* generalized these ideas, designating activity and passivity as “universal characteristics of sexual life” (p. 159).

In “Instincts and Their Vicissitudes” (1915c) Freud further elaborated these ideas, which led him from the use of clinical findings to an analysis of the internal mechanism of the drive. Every drive is active in itself; it is a “piece of activity” (p. 122). However, the aim of the drive, which is always satisfaction, can be achieved by various means. One way is the “change from activity to passivity” (p. 127). For instance, in sadism/masochism, the active goal of tormenting and watching is replaced by the passive goal of being tormented, of being watched. Therefore, three simultaneous or successive positions of the subject with respect to the object can result in satisfaction: active, passive (a rever-

sal back to oneself), and “reflected means” (observing oneself, self-inflicted pain). This flexibility of the instinctive aims of the drive contrasts with the fixity of perverse sexuality.

In developing his theory of psychosexuality, Freud closely linked the pairs activity/passivity and masculine/feminine, which he sometimes used as synonyms. In some texts, in fact, Freud’s clinical observations shows them to be nearly indistinguishable, for example, in the Wolf Man’s regression from passive desires to masochistic and feminine desires toward his father (1918b [1914]). Later and in a context less closely associated with individual clinical analysis, Freud insisted on the importance of not “identify[ing] activity with maleness and passivity with femaleness” (1930a, p. 106).

As for the role of active and passive in the theory of the ego, Freud, in 1915, emphasized that transformations of the drive by repression and reversal protect the psychic apparatus. These transformations depend on “the narcissistic organization of the ego and bear the stamp of that phase. They perhaps correspond to the attempts at defense which at higher stages of the development of the ego are effected by other means” (p. 132). The transformations between active and passive imply a narcissistic consistency and a drive that is also no longer “poorly connected and independent” (Freud, 1915c).

After 1920 and his introduction of the structural theory (ego, id, superego), Freud could refer to a passive ego confronting an id, or a masochistic or feminine ego confronting a sadistic superego (1928b). He then renewed his study of psychoses, melancholy, and trauma. It was around this time that Freud introduced the death drive and its essentially destructive effect through unbinding. With the notion of unbinding Freud could better distinguish the activity of the drive from its potential for destructive aggression. The internal organization of sadism/masochism (mastery, sadism, primary and secondary masochism) could then be conceived as protecting the psyche by binding the death drive (1924c). The repetition compulsion also reintroduces psychic binding through the interplay of activity and passivity in the face of trauma. This occurs during the child’s play when the child “makes the transition from passivity to activity [in order to] psychically control her impressions of life.” These perspectives are extensively explored in contemporary psychoanalytic work.

SERGE GAUTHIER

*See also:* Homosexuality; Instinctual impulse; Masculinity/femininity; Sadoomasochism; Turning around.

### **Bibliography**

- Freud, Sigmund. (1896b). Further remarks on the neuro-psychoses of defence. *SE*, 3: 157–185.
- . (1905d). Three essays on the theory of sexuality. *SE*, 7: 123–243.
- . (1915c). Instincts and their vicissitudes. *SE*, 14: 109–140.
- . (1918b [1914]). From the history of an infantile neurosis. *SE*, 17: 1–122.
- . (1924c). The economic problem of masochism. *SE*, 19: 155–170.
- . (1928b). Dostoevsky and parricide. *SE*, 21: 173–196.
- . (1930a). Civilization and its discontents. *SE*, 21: 57–145.

---

## **ACT, PASSAGE TO THE**

A particular kind of action defined by its disruptive and even criminal character. Whether the aggression characterizing such an act is directed at the self or at others, it is generally considered psychopathological. In “passage to the act” it is the idea of “passage” that is important, for it refers to the relationship between the act and the supposed mental process that prepares for and facilitates it.

The French term *passage à l'acte* was borrowed by psychoanalysis from psychiatry and criminology. It is important that this notion not be confused with that of acting-out/acting-in, which should be limited to the framework of the treatment and the dynamics of the transference. More generally speaking, passage to the act, like inhibited action and procrastination, raises the issue of the connection between thought and action. Freud emphasized on several occasions how one could be substituted for the other. In obsessions, for instance, thought replaced action by virtue of a kind of regression (1909d); in the case of primitive peoples, by contrast, the act seemed to replace thought in a way consonant with Goethe's dictum, “In the beginning was the deed” (1912–13a, p. 161).

It was not in a philosophical context that the notion of passage to the act was developed, however, but rather in connection with the often unpredictable

character of certain antisocial and violent acts. What the word “passage” denoted was the sudden lurch from a fantasied act to a real act, a shift that would normally be inhibited by defense mechanisms.

Jacques Lacan drew attention to the way anxiety was resolved by a passage to the act (1962–63). For many authors, passage to the act is the effect of a pre-oedipal mode of psychic functioning dominated by primary processes, by an inability to tolerate frustration, respect reality-testing, or curb a tendency to impulsiveness. In this view a weak ego may be responsible for a propensity to pass to the act; but a grandiose ego, eager to exert omnipotent control over its surroundings, can also be the culprit. The “act” here is more like a motor discharge than an action intended to transform reality, which requires the subject to delay the discharge by means of a thought-process permitting the psychic apparatus to endure tension so long as release is thus deferred (Freud, 1911b).

Passage to the act concerns the relationship between the act and its mentalization; it could indeed be regarded as a near-total exclusion of any mental process from the act. Any understanding of such an act, which is not assumed but rather presented by the agent as passively experienced, must depend on an effort of decipherment (Chasseguet-Smirgel, 1987; Balier, 1988). For this reason passage to the act has been likened to somatization, since both are characterized by a lack of psychic working-out, even by alexithymia.

Alternatively, it might be argued that passage to the act does not rely on an absence of mentalization, but rather on a kind of “telescoping” (Aulagnier, 1975/2001) of fantasy and reality. In this perspective, far from being the consequence of a failure of mentalization, the passage to the act results from an overflowing of the fantasy world into reality because an element of reality has impinged on the fantasy scenario and opened a breach enabling the act to externalize it.

It is hard, therefore, to reduce the notion of passage to the act to a simple causality. Instead, instances of passage to the act should be defined in terms of the particular individual involved, and their specific psychodynamic features examined case by case. Thus schizophrenic and paranoid homicidal passages to the act present considerable differences, even if both embody an inadequate attempt to dissipate unbearable anxiety. A paranoid passage to the act is liable to occur when the persecuting object is lost sight of and the

persecutory system is destabilized (Zagury, 1990). The passage to the act in borderline conditions depends rather on a lack of identifications (Bergeret, 2002), while such acts in adolescents may be fostered by the emergence of destabilizing instinctual impulses conducive to either excess or asceticism.

If one resists the temptation to simplify the notion, it appears that passage to the act may have a large variety of etiologies. Meanwhile, the notion clearly belongs to a very broad philosophical discussion of the relationship between thought and action.

SOPHIE DE MIJOLLA-MELLOR

*See also:* Abstinence/rule of abstinence; Acting out/acting in; Criminology and psychoanalysis; Thought.

### **Bibliography**

- Aulagnier, Piera. (1975). *The violence of interpretation: From statement to pictogram*. East Sussex, Philadelphia: Brunner-Routledge. (Original work published 1975)
- Balier, Claude. (1988). *Psychanalyse des comportements violents*. Paris: Presses Universitaires de France.
- Bergeret, Jean. (2002). Le passage à l'acte de l'état limite. In Frédéric Millaud (Ed.), *Le passage à l'acte: aspects cliniques et psychodynamiques* (pp. 111–117). Paris, Masson.
- Chasseguet-Smirgel, Janine. (1987). *L'acting out: quelques réflexions sur la carence d'élaboration psychique*. *Revue française de psychanalyse*, 51, 4.
- Freud, Sigmund. (1909d). Notes upon a case of obsessional neurosis. *SE*, 10: 151–318.
- . (1911b). Formulations on the two principles of mental functioning. *SE*, 12: 213–226.
- . (1912–13a). *Totem and taboo*. *SE*, 13: 1–161.
- Lacan, Jacques. (2004). *Le séminaire, Livre X: L'angoisse, 1962–1963*. Paris: Seuil.
- Millaud, Frédéric (Ed.). (2002). *Le Passage à l'acte: aspects cliniques et psychodynamiques*. Paris: Masson.

## **ACTUAL NEUROSIS/DEFENSE NEUROSIS**

The distinction between the actual neurosis and the neurosis of defense was made by Freud very early on in the context of his theory of the sexual origins of neurosis. In 1898, in an article entitled “Sexuality in the Aetiology of the Neuroses,” he clearly described these

two categories of neurosis in terms of both aetiology and treatment: “In every case of neurosis there is a sexual aetiology; but in neurasthenia it is an aetiology of a present-day kind, whereas in the psychoneuroses the factors are of an infantile nature” (1898a, p. 268). This contrast between actual and infantile sexuality in the causation of the two kinds of neurosis entailed correspondingly different therapeutic approaches, namely prophylaxis and deconditioning in the case of actual neuroses (pp. 275–76) and psychoanalysis in that of the defense neuroses.

Into the class of actual neuroses fell, chiefly, neurasthenia and anxiety neurosis. Later (1914c, p. 83), Freud added hypochondria. In his view the distinction between neurasthenia and anxiety neurosis depended on the specificity of the sexual noxa in each: “Neurasthenia can always be traced back to a condition of the nervous system such as is acquired by excessive masturbation or arises spontaneously from frequent emissions; anxiety neurosis regularly discloses sexual influences which have in common the factor of reservation or of incomplete satisfaction” (1898a, p. 268). The mechanism of actual neurosis was essentially linked to a disjunction between the somatic sexual excitation and object representations in the unconscious. This failure of somatopsychic communication was caused by particular conditions of mental functioning and generally led to symptoms.

The defense neuroses subsumed conversion hysteria, anxiety hysteria (phobic neurosis), and obsessional neurosis. In contrast to the actual neuroses, they were caused by psychic conflict. In “The Neuro-Psychoses of Defense” (1894a), Freud described the mechanism of these conditions as a disjunction between ideas and affects. The idea, erotic in character, underwent repression, whereas the affect had a specific fate for each type of neurosis: somatic conversion in hysteria, displacement in obsessional neurosis, and projection in phobic neurosis.

Freud rounded out his psychodynamic conception of the defense neuroses in 1906, in “My Views on the Part Played by Sexuality in the Aetiology of the Neuroses,” describing neurotic symptoms as compromises between two mental currents: the libidinal current, determined by the subject’s sexual “constitution,” and the repression carried out by the ego (1906a, p. 277).

The distinction between actual and defense neuroses has taken on fresh significance in present-day

psychoanalysis as a result of new thinking on psychosomatic disorders. The fact that it corresponds so closely with the distinction drawn by Pierre Marty in his classification of psychosomatic conditions between well and badly-mentalized neuroses has led to its becoming both a model for the economic assessment of psychosomatic processes and a frame of reference for the analysis of clinical findings.

In this perspective, the symptoms of actual neuroses belong to the same instinctual framework as those of hysteria and, more generally, those of the transference neuroses. What differentiates them is the specific process affecting sexuality and the relations between the instincts. This postulate is the foundation of Freud's psychosomatic monism and shifts the duality into the instinctual realm.

The somatic symptoms of actual neurosis express more or less far-reaching material degradation of organs and functions. From the psychoanalytical standpoint, however, we must treat them, along with Freud, as resulting from the intensification of the organ's erotogenic function and from the distortion of the action of the instinct in its own terms. It is only logical, if psychosomatic phenomena are to be considered from the standpoint of psychoanalysis, that all reference to any conceptual framework other than the instinctual one be excluded from a comprehensive approach to the somatic symptom or to somatic illness.

Such an approach must be congruent with the internal coherence of the psychoanalytic apparatus, a coherence with three dimensions, clinical, theoretical, and therapeutic. From the psychic point of view, which is to say from the point of view of psychosexuality, the organization of the actual neuroses is characterized by an overall incapacity for working matters out, and this for determinate reasons of both a structural and a developmental kind. This is the reason why patients suffering from such neuroses have been excluded from psychoanalysis intervention, the sole purpose of which for Freud was to uncover the role of the unconscious in mental life—a point about which he was categorical. In his twenty-fourth Introductory Lecture, entitled “The Common Neurotic State,” he noted that, “It was more important for me that you should gain an idea of psycho-analysis than that you should obtain some pieces of knowledge about the neuroses; and for that reason the ‘actual’ neuroses, unproductive so far as psycho-analysis is concerned,

could no longer have a place in the foreground” (1916–17a, p. 389). Thus the classification of actual neurosis could not be applied to any mental organization in which psychoanalysis was led to identify psychic conflicts or defense mechanisms such as repression—these being firm indications, in Freud's eyes, of psychoneurosis.

In his broad conception of the neuroses, however, Freud included the actual neuroses, clearly defining their place and according them an important role with not inconsiderable theoretical consequences: “A noteworthy relation between the symptoms of the ‘actual’ neuroses and of the psychoneuroses makes a further important contribution to our knowledge of the formation of symptoms in the latter. For a symptom of an ‘actual’ neurosis is often the nucleus and first stage of a psychoneurotic symptom” (1916–17a, p. 390). This view of things opens up a whole area of psychosomatic research; it also provides the theoretical context for Freud's notion of somatic compliance.

CLAUDE SMADIA

*See also:* Conversion; Disorganization; Excitation; Hypochondria; Psychosomatic; Symptom-formation.

### **Bibliography**

- Freud, Sigmund. (1894a). The neuro-psychoses of defence. *SE*, 3: 41–61.
- . (1898a). Sexuality in the aetiology of the neuroses. *SE*, 3: 259–285.
- . (1906a). My views on the part played by sexuality in the aetiology of the neuroses. *SE*, 7: 269–279.
- . (1914c). On narcissism: An introduction. *SE*, 14: 67–102.
- . (1916–17a [1915–1917]). Introductory lectures on psycho-analysis. *SE*, 15–16.

### **Further Reading**

- Gediman, Helen K. (1984). Actual neurosis and psychoneurosis. *International Journal of Psychoanalysis*, 65, 191–202.
- Hartocollis, Peter. (2002). “Actual neurosis” and psychosomatic medicine. *International Journal of Psychoanalysis*, 83, 1361–1374.
- Kaplan, Donald B. (1984). Some conceptual and technical aspects of the actual neurosis. *International Journal of Psychoanalysis*, 65, 295–306.

## ACUTE PSYCHOSES

The notion of acute psychosis as envisaged by psychiatry is situated on the border of psychoanalysis. The acute psychoses, sudden and severe disorganizations of the mind, all have in common a disturbance of the relational faculties, a loss of contact with what is commonly accepted as reality, and a diminishing or absence of critical abilities with regard to the pathological.

There are multiple different forms of acute psychosis. Among these are melancholic and manic episodes, which can clinically exist in alternation (hence the framework of manic-depressive psychosis) and which are associated with Freud's writings on the "narcissistic neuroses"; acute delusional psychoses, some of which are linked to the development of chronic psychosis; and finally, dream-confusion disorders, for which the possibility of an organic etiology must always be investigated. As varied as they are, these disorders all have in common the temporal features of an "attack": They are sudden, uncontrollable, incomprehensible, and reversible.

Since antiquity, *melancholia* has referred to a form of madness characterized by "black bile": dejection, sadness, spiritual pain, feelings of abjection and guilt that may be expressed in delusional form, and despair that may lead to suicide. Emil Kraepelin incorporated melancholia into manic-depressive psychosis. Karl Abraham, in his 1912 publication "Notes on the Psycho-Analytical Investigation and Treatment of Manic-Depressive Insanity and Allied Conditions," attempted to apply a psychoanalytic approach to cases that were "cyclical" (1912/1927, p. 138) in their evolution. His way of envisioning the psychogenesis of the attack, and his reference to a "hidden structure" and ambivalence stimulated the thinking of Sigmund Freud, who had been investigating melancholia as early as 1895. In a manuscript sent to Wilhelm Fliess that year, Freud compared it to "mourning—that is, longing for something lost" (Manuscript G, p. 200). In 1917 he published "Mourning and Melancholia," where he envisioned melancholia as the pathological form of mourning. In the work of mourning, the subject is able to gradually achieve detachment from the lost object; in melancholia, by contrast, the subject identifies with the lost object and believes himself or herself to be guilty of its disappearance.

The acute psychoses, and especially attacks of melancholia, owing to their frequent recurrence and

possible alternation with mania, from the outset presented psychoanalysis with the problem of the relationship between attack and structure. "Structure" implies that no term of the field in question can be approached without taking into consideration the terms that are articulated together with it; no single term takes effect without the others. The three conditions that Freud posited as the origin of melancholia—loss of the object, ambivalence, and regression of the libido into the ego—provide the framework of a structure. Whatever may reactivate such a mechanism around the loss of object provokes another melancholic attack, and Freud explored this "struggle of ambivalence" (1916–1917g [1915], p. 257) in which the ego itself becomes carried away in the process of accusation of the object, or even its "condemnation to death." He posited that this process can come to an end in the unconscious, either through exhaustion or through exclusion of the object, which is thereafter deemed worthless. The ego can then revel in the satisfaction of recognizing itself as the best, as superior to the object. The accumulation of a cathexis that is at first bound, and then liberated at the end of the melancholic process—the enabling condition for possible mania—implies regression of the libido to narcissism. In *The Ego and the Id* (1923b), he analyzed the ego's dependency states, writing: "If we turn to melancholia first we find that the excessively strong super-ego which has obtained a hold upon consciousness rages against the ego with merciless violence" (p. 53). What dominates the superego here is "a pure culture of the death instinct" (p. 53). In "Neurosis and Psychosis" (1924b [1923]) he restricted the "narcissistic neuroses," characterized by withdrawal of the libido onto the ego, to disorders of the melancholic type.

In order to envisage acute psychoses as a whole, Melanie Klein's theoretical elaboration must be mentioned. In 1935 Klein stopped referring to "developmental stages" and instead began using the term *position* to differentiate psychotic anxieties in children from psychoses in adults. In this view, psychosis is seen sometimes as a temporal regression reversible to either the paranoid or the depressive position, sometimes as the "fertile moment" of a psychosis arrested in such a "position," and sometimes as a cyclical episode that can be clinically treated, even if the subject's anchorage in such a "position" remains structurally determined.

It should be noted that the various acute psychoses were the object of a clinical and psychopathological



synthesis by Henri Ey (in the third volume of his *Études psychiatriques*) that often challenges psychoanalysis.

Acute psychosis is an expression of the complexity of what is happening on different levels in the patient; the possibility of some severe organic dysfunction cannot be ruled out, nor can the possibility of a reactive crisis. In any event, the patient's acute state requires specific types of care, and his or her history is essentially done away with by the urgency of the circumstances. The anguish of people close to the patient and the team of caregivers in the face of madness must be taken into account. Research confirms the effectiveness of a psychotherapeutic approach based on psychoanalytic conceptions associated with traditional methods of treatment of the acute episode. In the most favorable conditions, such an approach still makes structural study possible.

MICHEL DEMANGEAT

*See also:* Mania; Melancholic depression; Organic psychoses; Postnatal/postpartum depression; Psychotic/neurotic

### **Bibliography**

Abraham, Karl. (1927). Notes on the psycho-analytical investigation and treatment of manic-depressive insanity and allied conditions. In *Selected papers on psycho-analysis*. (Douglas Bryan and Alix Strachey, Trans.). Hogarth Press: London. (Original work published 1912)

Ey, Henri. *Traité de psychiatrie clinique et thérapeutique*. Paris: E.M.-C., 1955.

Freud, Sigmund. (1916–17g [1915]). Mourning and melancholia. *SE*, 14: 237–258.

———. (1923). The ego and the id. *SE*, 19: 1–66.

Klein, Melanie. (1975). A contribution to the psychogenesis of manic-depressive states. In *The writings of Melanie Klein* (Vol. I, pp. 262–289). London: Hogarth. (Reprinted from *International Journal of Psycho-Analysis*, 16 (1935), 145–174.)

### **Further Reading**

Knight, Robert P. (1945). Use of psychoanalytic principles in therapy acute psychosis. *Bulletin of the Menninger Clinic*, 9, 145–154. Anal Sadistic Stage

Shengold, Leonard. (1985). Defensive anality and anal narcissism. *International Journal of Psychoanalysis*, 66, 47–74.

———. (1988). *Halo in the sky: Observations on anality and defense*. New York: Guilford Press.

## **ADAPTATION**

Adaptation is not part of Freudian vocabulary (it does not appear in the index of the Standard Edition, for example). The idea of adaptation, however, is present throughout Freud's work. It appears as early as 1895, in his "Project for a Scientific Psychology" (1950a), when he discusses the mechanisms of perception, attention and memory. The idea runs through all of Freud's subsequent work whenever he discusses the relation between psychic reality and the "reality of the outside world." It is found, for example, in "Instincts and their Vicissitudes" (1915c) and "Repression" (1915d), when he writes that dangers that can't be avoided through behavioral means are "rejected toward the interior." Other texts where the concept appears include "Neurosis and Psychosis" (1924b), "The Loss of Reality in Neurosis and Psychosis" (1924e), and "An Outline of Psycho-Analysis" (1940a). In fact, there are few texts by Freud where the question of adaptation isn't found, even if the word itself rarely appears.

Adaptation and the related theoretical issues are central to the development of ego-psychology, which was, for the most part, based on Freud's structural theory and the work of Anna Freud (1936/1937) and Heinz Hartmann, author of *Ego Psychology and the Problem of Adaptation* (1938/1958). It was in this period that a theoretical schism developed, leading to differences in clinical psychoanalytic practice between those analysts (especially English-speaking) who adapted this point of view and those who preferred other options, either along the lines developed by Melanie Klein and her successors or the rather different approach taken by Lacan and his successors.

Jacques Lacan was, in fact, highly critical of the primacy given to the problems of adaptation in ego-psychology. He emphasized that naively establishing "external reality" as a given prior to and outside of psychic activity is a theoretical absurdity since that exterior reality is constructed through close interaction with psychic reality itself. He also pointed out the dangers of an analytical practice in which the analyst, within the framework of a normative and "normalizing" enterprise, developed mastery, or even a sense of excessive power, in assuming that his or her own "adaptation" is by definition better than that of the patient. Whatever one might think of these criticisms and their rebuttals, there is little doubt that they have had considerable impact, well beyond the field of

Lacanian thought, especially in the French-speaking world. Unfortunately, this has had the effect of “throwing the baby out with the bathwater” through the unjustified condemnation of any psychoanalytic consideration of the problems of adaptation. These problems cannot be avoided, however, to the extent that psychic processes are constantly being adjusted in terms of their internal equilibrium and modified as a result of the impact of outside events.

ROGER PERRON

*See also:* Defense; Ego; *Ego Psychology and the Problem of Adaptation*; Individuation (analytical psychology); Kardiner, Abram; Normality; Pichon-Rivière, Enrique; Self (true/false).

### Bibliography

Canguilhem, Georges. (1989). *The normal and the pathological* (Carolyn R. Fawcett & Robert S. Cohen, Trans.). New York: Zone Books. (Original work published 1966)

Freud, Anna. (1937). *The ego and the mechanisms of defense*. London: Hogarth Press. (Original work published 1936)

Freud, Sigmund. (1915c). Instincts and their vicissitudes. *SE*, 14: 109–140.

———. (1915d). Repression. *SE*, 14: 141–158.

———. (1924b [1923]). Neurosis and psychosis. *SE*, 19: 147–153.

———. (1924e). The loss of reality in neurosis and psychosis. *SE*, 19: 180–187.

———. (1940a [1938]). An outline of psycho-analysis. *SE*, 23: 139–207.

———. (1950a [1887–1902]). Extracts from the Fliess papers. *SE*, 1: 173–280.

Hartmann Heinz. (1958). *Ego psychology and the problem of adaptation* (David Rapaport, Trans.). New York: International Universities Press. (Original work published 1938)

## ADDICTION

The Latin *addictus* refers to a person who is bound and dependent as a result of unpaid debts. Metaphorically, this term came to be used for any behavior that results from a heavy dependence on something, such as a drug. A number of common substances or those that can be freely purchased can be used as drugs or

become addictive substances: medication, alcoholic beverages, glue, and so on. Psychoanalytically, the power of a particular addiction depends both on the unconscious fantasies that underlie the subject’s ingestion, and the substance’s actual chemical effect.

Sigmund Freud refers to addiction in an early paper on “Hypnosis” (1891d, p. 106), and in a letter to Wilhelm Fliess of December 22, 1897, he refers to masturbation as the “primary addiction” (1950a, p. 272; 1985c, p. 287). Karl Abraham (1908/1927) studied alcohol addiction. Sándor Radó (1933) associated addiction with a regression to childhood. Otto Fenichel (1945) developed the concept of addiction as a regression to infantile stages, and his descriptions of alcohol as a means of diluting the superego are especially interesting. Herbert Rosenfeld (1965) referred to the manic-depressive signs that underlie addiction, and connected addiction to pathological narcissism of the Self. Donald Winnicott (1951/1953) associated addiction with a pathology of the transitional. Winnicott’s transitional object, a creation/discovery of the subject, opens up an intermediary zone of experience, which then expands into play and cultural life, while the transitional object is disinvested and loses its meaning. In addiction, this process of opening up and development is held back, and the transitional object continues to carry out its original function (counteracting depressive anxiety), in the form of a continuing disavowal. The transitional object is concretized, is “fetishized,” and becomes susceptible to replacement by a drug as an object that can be manipulated by the omnipotent subject, enabling him to deny the separation and the resulting depression.

A number of authors who have studied compulsive behavior have included a dependence on alcohol or another substance into their inquiry. Dostoyevsky, in *The Brothers Karamazov*, provides a clear description of the motivations that underlie addictive behavior, such as sexual dependency and pathological games.

Addiction to a substance is sometimes replaced with another form of dependence, for example, addictions to food, to sex with prostitutes, to gambling, to spree-buying, to physical exercise, to web surfing, or to playing video games (whereby the internal world is projected onto the characters who fight, kill, love, or hate on screen). There is also the addiction to pseudo-religious cults, which serves as a substitute for a dependence on and subjugation to drugs. It is important to note that the other can also become an addictive object

(McDougall, 1982), serving as a drug might, to fill holes in the subject's identity.

DAVID ROSENFELD

*See also:* Alcoholism; Alienation; Cocaine and psychoanalysis; Dependence; Dipsomania; *Freud: Living and Dying*; Passion.

### **Bibliography**

- Abraham, Karl. (1927). The psychological relations between sexuality and alcoholism. In *Selected papers on psychoanalysis*, London: Hogarth Press. (Original work published 1908)
- Freud, Sigmund. (1891d). Hypnosis. *SE*, 1: 103–114.
- . (1897a). Infantile cerebral paralysis. (Lester A. Russin, Trans.). Coral Gables, FL: University of Miami Press, 1968.
- . (1950a [1887–1902]). Extracts from the Fliess papers. *SE*, 1: 173–280.
- . (1985c [1887–1904]). *The complete letters of Sigmund Freud to Wilhelm Fliess, 1887–1904* (Jeffrey M. Masson Ed. and Trans.). Cambridge, MA, London: Belknap/Harvard University Press.
- Fenichel, Otto. (1945). *The psychoanalytic theory of neurosis*. New York: W.W. Norton.
- McDougall, Joyce. (1982). The narcissistic economy and its relation to primitive sexuality. *Contemporary Psychoanalysis*, 18, 373–396.
- Radó, Sándor. (1933). The psychoanalysis of pharmacothymia. *Psychoanalytic Quarterly*, 2, 1–23.
- Rosenfeld, Herbert. (1965). *Psychotic states: A psychoanalytic approach*. London: Hogarth Press.
- Winnicott, Donald W. (1953). Transitional objects and transitional phenomena, a study of the first not-me possession. *Collected papers, through paediatrics to psycho-analysis* (pp. 229–242). (Reprinted from *International Journal of Psycho-Analysis*, 34 (1951), 89–97.)

---

## **ADHESIVE IDENTIFICATION**

At very early stages the infant fails to develop a sense of a containing skin. It can then only gain a sense of holding together by sticking, in fantasy, to the outside of objects, giving rise to a form of mimicry which Esther Bick termed adhesive identification. The concept first appears in a Donald Meltzer publication (1975).

Esther Bick's infant observation work showed the skin as a primary object stabilizing the ego in the paranoid-schizoid position. She described the most primitive experiences of falling apart in pieces or, even worse, as a shapeless liquid leaking out. She also described protective measures that an infant may perform with its body and its perception in order to give a greater experience of remaining coherent and contained. She noticed various muscular or verbal abilities which developed precociously as if they were methods for substituting a second skin over a leaky primary containing object.

Certain children, however, seem to have been particularly doomed to the experience of leaking, and almost all emotional experience is felt as a rent in the containing skin. Such a raw experience of bleeding and leaking may then be covered by a particular form of sticking to an object, adhering to it. That person is then incorporated as the skin that prevents leaks.

One of the consequences is that while the concentration is upon sustaining a complete surface, there is no sense of depth to the person. He feels literally that he cannot contain. Ordinary projection and introjection are not possible.

This process gives rise then to a form of object-relationship in which there is a very shallow attempt at mimicry of the object, in contrast to an identification in which the identity of the other person is more richly carved into the person's own self. This description of very early phenomena has been useful in understanding infantile autism (Meltzer et. al., 1975; Tustin, 1981).

The "skin ego" concept of Didier Anzieu (1985) is a more versatile notion, being applicable outside the psycho-analytic setting, in groups and organizations. Pierre M. Turquet (1975) also used the notion of the skin as container in large group experience.

The infantile notion of the skin and its deviations (adhesive identification and the "second skin ") can appear to have reductionist properties, since all phenomena at a later stage can be attributed to experiences at the level of developing the skin boundary. In addition, there is a problem in that the theories of the skin and adhesive identification were derived firstly from a non-psychoanalytic setting (infant observation, and in group phenomena) so that its status in psycho-analytic work, practice and theory, is disputed.

ROBERT D. HINSHELWOOD

See also: Autism; Autistic capsule/nucleus; Dismantlement; Infant development; Infant observation (therapeutic).

### **Bibliography**

- Anzieu, Didier (1989) *The skin ego*. New Haven-London: Yale University Press. (Original work published 1985)
- Bick, Esther. (1968). The experience of the skin in early object relations. *International Journal of Psycho-Analysis*, *XLIX*, 558–566.
- . (1986). Further considerations on the functioning of skin in early object relations: findings from infant observation integrated into child and adult analysis. *British Journal of Psychotherapy*, *II*, 292–299.
- Meltzer, Donald. (1975). Adhesive identification. *Contemporary Psycho-Analysis*, *11*, 289–310.
- Turquet, Pierre. (1975). Threats to identity in the large group. In L. Kreeger (Ed.) *The large group* (p. 87–114). London: Constable.
- Tustin, Frances. (1981). *Autistic states in children*. London: Routledge.

## **ADLER, ALFRED (1870–1937)**

An Austrian physician, psychologist, and psychotherapist, Alfred Adler was born February 7, 1870, in Vienna and died May 28, 1937, in Aberdeen, Scotland. The son of a grain merchant, he was raised in Vienna and received his medical degree in 1895. After opening his medical practice, he took an interest in social issues and, in 1902, became part of Sigmund Freud's circle of friends. He was one of the most active members of the group and one of the most original. After creating the International Psychoanalytic Association (IPA) in 1910, he became the head of the Vienna group and, with Stekel, became co-editor of the *Zentralblatt für Psychoanalyse*, founded the same year.

In 1911 he left the IPA with nine other members because of irreconcilable theoretical differences and founded the Verein für Freie Psychoanalytische Forschung (Society for Free Analytic Research), which he transformed in 1913 into the Verein für Individualpsychologie (Society for Individual Psychology). After 1914 he was editor (with Carl Furtmüller) of his own publication, *Zeitschrift für Individualpsychologie* (Journal of Individual Psychology), the publication of which was interrupted in 1916, becoming, in 1923, the *Internationale Zeitschrift für Individualpsychologie*

(International Journal of Individual Psychology). In 1912 he tried to obtain a research position at the University of Vienna, but was refused.

Interested in practice and educational issues in particular, after 1919 he established a number educational clinics (for teachers, parents, and students), which served as models for practitioners abroad. In 1929 he created the first dispensary of individual psychology (for adults and children). He was also involved in the training of teachers, for he had worked at the Vienna teacher's college since 1924, which brought him closer to the city's educators, on whom he exercised considerable influence.

After 1926 he gave lectures throughout Europe and the United States, initially at Columbia University, then, after 1933, as professor of medical psychology at the Long Island College of Medicine in New York, as well as a consultant at the hospital. To honor him for his scientific achievements, he was named an honorary citizen of the city of Vienna in 1930 and was made a doctor *honoris causa* in the United States, to which he had emigrated in 1935, primarily for political reasons.

His two major works are *A Study of Organ Inferiority and its Psychological Compensation: A Contribution to Clinical Medicine* (1907) and *The Neurotic Constitution* (1912/1972), in which he makes a clear break with Freud. *The Practice and Theory of Individual Psychology* (1927), *Understanding Human Nature* (1927), and *Die Technik der Individualpsychologie* (1928–1930) were the result of his many talks, and were intended for a broader public.

Adler rejected Freud's theory of the libido and, with the creation of individual psychology, which was developed as a new direction in psychotherapy, he created the first significant schism in the psychoanalytic movement. He considered the individual as a complete being, including social and sociological aspects that began with the infant's feelings of inferiority, compensation, and the search for power and supremacy, as well as the sense of belonging to a collectivity. Adler considered psychic development to be the formation of an unconscious life plan, or even a lifestyle, starting with early childhood, and that later symptoms had to be taken into account from this point of view—in this sense Adler's approach was teleological. As an ego-centered psychology, Adler's individual psychology has had its greatest influence

on other psychotherapeutic currents, such as humanist psychology and neoanalysis.

HELMUT GRÖGER

*See also:* Aggressiveness; Austria; Femininity, rejection of; Monism; Masculine protest (individual psychology); Aggressive instinct/aggressive drive; Inferiority, feeling of; *Minutes of the Vienna Psychoanalytic Society*; Wiener psychoanalytische Vereinigung.

### **Bibliography**

- Adler, Alfred. (1927). *The practice and theory of individual psychology*. New York: Harcourt Brace.
- . (1927). *Understanding human nature* (Walter Béran Wolfe, Trans.). New York: Greenberg.
- . (1928–1930). *Die Technik der Individualpsychologie*. München: Bergmann.
- . (1972). *The neurotic constitution* (Bernard Glueck and John E. Lind, Trans.). Freeport, N.Y.: Books for Libraries Press (Original work published 1912).
- Hoffman, Edward. (1994). *The drive for self: Alfred Adler and the founding of individual psychology*. Reading, MA: Addison-Wesley.
- Schiferer, H. Rüdiger, Gröger, Helmut, and Skopec, Manfred. (1995). *Alfred Adler: eine Bildbiographie. Mit bisher unbekanntem Original-Dokumenten und zum grössten Teil unveröffentlichten Abbildungen*. Munich-Basel: Ernst Reinhardt.

## **ADOLESCENCE**

In psychoanalysis, adolescence is a developmental stage, a key moment during which three transformations occur: the disengagement from parental ties that have been interiorized since infancy; the sexual impulse discovering object love under the primacy of genital and orgasmic organizations; and identification, the impetus for topographic readjustment and the affirmation of identity and subjectivity. These transformations begin with the onset of adolescence, concluding when infantile sexual activity has reached its final form. Adolescence is, therefore, a completion of the process of ego maturation. It is characterized by the conflict that these transformations bring about and the ensuing crisis resulting from the wish for adult sexual activity and the fear of giving up infantile pleasure.

There is little discussion of the concept of adolescence in Freud's own writing. However, the term

“puberty” is frequently found. More than two hundred and fifty references to the concept have been found in his work, even outside of the *Minutes of the Vienna Psychoanalytic Society*. Referring to the Standard Edition, the majority of entries catalogued for the word “adolescence” are found in the *Studies on Hysteria* (1895d) and half of them are by Joseph Breuer. However, the references do not fully take into account linguistic issues and the associated problems of translation. For example, in the majority of French translations of Freud's work, there is frequent reference to the term “adolescence.”

Although adolescents appear among the first cases of clinical psychoanalysis, such as that of Katharina, who was eighteen at the time, and especially that of Dora, most references to the role of puberty from the perspective of development appear in *Three Essays on the Theory of Sexuality* (1905d). In *Some Reflections on Schoolboy Psychology*, (1914f), a text that is often mentioned in connection with adolescence, the problem of growing up is presented by Freud as an extension of the oedipal complex. The schoolboys see their teachers as substitute parents. They transfer to them the ambivalence of the feelings they once had for their father. From this point of view, adolescence works toward a separation from the father.

Although adolescence in Freud and in subsequent psychoanalytic thought is often presented as an infantile screen-memory, that is, as the formation of a compromise between the repressed elements of infantile sexuality and the defenses typical of adolescence, it is also, through the theory of deferred action, an opportunity for new psychic activity, a kind of rebirth in which the past can only be understood in light of the present. Human history is understood in terms of its past, but its past is illuminated in terms of its present, and, in the case of adolescence, in terms of the traumatic present.

In fact, psychoanalysts have always had, whether manifestly or latently, a bipolar idea of adolescence. First, as the occasion of two instinctual currents through which the adolescent, burdened by the re-emergence of infantile impulses on the one hand and the discovery of orgasm (arising in adolescence) on the other, must confront oedipal conflicts, the now realizable threat of incest, and the parricidal and matricidal feelings as condensations in fantasy of the aggression associated with all growth: “growing up is by nature an aggressive act” (Donald Winnicott).

Second, as an expression of the bipolarity of the ties between impulse and defense (Anna Freud), between identification and identity (Evelyne Kestenberg), between object libido and narcissistic libido (Philippe Jeammet), and between the “pubertary,” which reflects the powerful sensual current that no longer recognizes its goals, and “*adolescens*,” which reflects the category of the ideal (Philippe Gutton). This leads contemporary psychoanalysts to consider that the capacity of the psychic apparatus to perform the work of binding can be seen as a fundamental indicator of the fact that the process of adolescence has been harmoniously completed. Dreams and action represent the creative activities of this capacity (François Ladame) whereas unbinding (Raymond Cahn) is the source of serious psychic pathology. The enigmatic discrepancy between the bipolarity of the impulse and the transformational object (Alain Braconnier) constantly underlies the analysis of transference and counter-transference during adolescence.

There are other theorizations as well: Adolescence as a “crisis” (Pierre Mâle, Evelyne Kestenberg) or breakdown (Moses Laufer), as an impasse in the process of development, that is, in the integration of the sexualized body into the psychic apparatus. These approaches reveal the difficulties and resistances the subject experiences in giving up the forms of libidinal satisfaction in which his infantile body was engaged, difficulties and resistances that are manifest in the transference through the representation and acting out of the “central masturbation fantasy.”

Although it is no longer psychoanalytically possible to consider adolescence in terms of a traditional genetic psychoanalytic psychology, that is, as the final stage of development that makes it possible to access an adult stage, it is still difficult to provide a comprehensive interpretation centered on any given aspect of adolescence. The psychic impact of puberty determines the remodeling of identification, the expression of fantasies, and self and object representations. The psychic impacts of the social and the cultural determine the alterations of these same intrapsychic elements, as well as presenting psychoanalysts with the problem of addressing the contradiction between a focus on external objects versus a focus on internal objects. From the point of view of psychoanalytic practice, the attention given to mental functioning, and to affects in particular, enables psychoanalysts to understand many of the disturbances found in adolescence

in a way that broadens and extends the notion of crisis or the process of individuation, as well as their relationship to anxiety and, especially, depression. The concepts of “depressive threat” and “self-sabotage” help describe, clinically and theoretically, the process of change specific to the adolescent, whose pathology reveals the failures and avatars that are so magnificently exemplified in our culture through the heroic figures of Narcissus, Oedipus, Hamlet and Ophelia, Electra and Orestes, and, of course, Romeo and Juliet.

ALAIN BRACONNIER

*See also:* Acting out/acting in; Adolescent crisis; Anorexia nervosa; Blos, Peter; Bulimia; Fairbairn, William Ronald Dodds; “Fragment of an Analysis of a Case of Hysteria” (Dora/Ida Bauer); Genital love; Identification; Identity; Infantile schizophrenia; Mâle, Pierre; Puberty; Screen memory; Self-representation; Silberstein, Eduard; Suicidal behavior; Transgression; *Young Girl's Diary*, A.

### **Bibliography**

- Blos, Peter. (1987). L'insoumission au père ou l'effort adolescent pour être masculin. *Adolescence*, 6 (21), 19–31.
- Cahn, Raymond. (1998). *L'Adolescent dans la psychanalyse: l'aventure de la subjectivation*. Paris: Presses Universitaires de France.
- Freud, Sigmund. (1905d). Three essays on the theory of sexuality. *SE*, 7: 130–243.
- Freud, Sigmund, and Breuer, Josef. (1895d). Studies on hysteria. *SE*, 2: 48–106.
- Jeammet, Philippe. (1994). Adolescence et processus de changement. In D. Widlöcher (Ed.) *Traité de psychopathologie* (pp. 687–726). Paris: Presses Universitaires de France.
- Laufer, Moses. (1989). *Adolescence et rupture du développement: une perspective psychanalytique*, Paris: Presses Universitaires de France.

### **Further Reading**

- Blos, Peter. (1962). *On adolescence. a psychoanalytic interpretation*, New York: The Free Press of Glencoe.
- . (1979). *The adolescent passage: developmental issues*, New York: International Universities Press.
- Emde, Robert. (1985). From adolescence to midlife: remodeling the structure of adult development. *Journal of the American Psychoanalytic Association*, 33(S), 59–112.
- Esman, Aaron. (ed.) (1975). *The psychology of adolescence, essential readings*, New York: International Universities Press.

Hauser, Stuart T. and Smith, Henry F. (1991). The development and experience of affect in adolescence. *Journal of the American Psychoanalytic Association*, 39(S), 131-168.

Novick, Kerry Kelly and Novick, Jack. (1994). Postoedipal transformations: latency, adolescence, pathogenesis. *Journal of the American Psychoanalytic Association*, 42,143-170.

Sarnoff, Charles. (1987). *Psychotherapeutic strategies in late latency through early adolescence*, Northvale, NJ: Aronson.

## ADOLESCENT CRISIS

The concept of adolescent crisis is not generally found in the vocabulary of psychoanalysis. It was not used by Freud and was not created by any psychoanalyst. In France the concept gained currency following the success of Maurice Debesse's *La crise d'originalité juvénile* (The crisis of juvenile originality; 1941), which helped spread and popularize the concept. Subsequently, authors interested in adolescence, including psychoanalysts, picked up the term for their own uses, supporting it or criticizing it. The initial ambiguity and lack of precision associated with the term probably contributed to its success, but also turned it into a grab-bag of ideas and the source of considerable misunderstanding. It has been used to refer to the culmination of the developmental process at the end of childhood and the beginning of adulthood, as well as to the behavioral manifestations and disturbances that so often occur at this age.

Under the heading of "adolescent crisis" and in the guise of the assumed originality of adolescents, the most atypical behavior has been considered "normal" for this age. This atypical behavior is claimed to be the price paid for the crisis, which has been compared to a temporary disorganization when the young adolescent leaves the stable environment of childhood for an as yet uncertain adulthood. Along with this change in environment must be considered the maturation of the drives, quantitative effects that are said to push the adolescent toward temporary anarchic behavior before it is channeled into more stable pursuits. The crisis, understood from its most obvious expression in a range of boisterous behavioral expressions, is said to be a sign of normality. On the contrary, the lack of such drama in adolescence would be a sign of excessive repression and a portent of a disturbed future. The adolescent would face no psychic work in making the transition to adulthood.

An alternate approach, based largely on the North American developmental school, known through the

work of Peter Blos and Margaret Mahler, sees adolescence as the culmination of a process of maturation. This developmental approach further suggests that we use the concept of crisis sparingly. It belongs more to a romantic vision of adolescence than to any scientific reality. According to this view, some adolescences would be pathological, but most, the silent majority, would not. Follow-up studies of difficult adolescences, although fragmentary, suggest that the evolution in adolescence is far from being as favorable as claimed. Yet the vast majority of adolescences go unnoticed, without any of the customary clinical or subjective manifestations of an adolescent crisis.

The psychoanalytic approach to the intrapsychic changes associated with puberty has developed in several phases. Three main explanatory models have been proposed, each of which can be seen as a confirmation of the others. The initial model of change was based on the first discoveries in psychoanalysis, those associated with *Studies on Hysteria* (1895d) and *The Interpretation of Dreams* (1900a). This model of change enabled the transition from symptoms to representations as a result of the change in the topographical register from the unconscious to the conscious through the lifting of repression. This model characterizes the Freudian approach to adolescence. Action deferred until puberty actualizes and brings into the field of consciousness, more or less disguised, the parameters of infancy and in particular the Oedipus complex, repressed during the latency period. Adolescence becomes a repetition of infancy. The second model of change is based on the displacement of libidinal investment. It was taken up by Anna Freud when she made mourning the central parameter of the process of adolescence. The third model is a structural change of personality.

Freud's view of adolescence is not without ambiguity and seems to alternate between change and continuity, though it leans toward the latter interpretation. Adolescence is essentially defined by its relation to infancy. It represents access to the genital stage and is, in this sense, the culmination of libidinal evolution (Freud, 1905d). Consequently, it clarifies earlier stages and gives deferred meaning to certain infantile experiences that have remained suspended and potentially traumatic until pubertal genital development provides them their fullest expression.

Little has been said concerning the intrapsychic transformations of puberty. In these models, the

understanding of adolescence is filtered through the understanding of childhood. The advantage of adolescence lies in its ability retrospectively to clarify childhood through the retroactive effect of the two-stage evolution of human sexuality and to serve as the doorway to adulthood. As a transitional period, it has no density of its own. The changes of adolescence are seen only as the continuation of a process begun at the start of personality development. Adolescence is not so much a crisis as a culmination of what existed embryonically in the infant.

The real change should be sought within obstacles to development, that is, in pathology and what Moses and Eglé Laufer refer to as “breaks in development.” For these authors, the adolescent’s pubescent body becomes a stand-in for the dangerous incestuous parent. Actualization through transference of this conflict-ridden oedipal bond enables the unconscious or preconscious fantasy that structures this bond to be brought up to date in what the authors refer to as the “central masturbatory fantasy.” They assign this fantasy a key role in the adolescent’s bond with his objects and his own body—a representative of parental objects. In accordance with Freudian ideas, the fantasy is organized during infancy, but the changes to the body in adolescence are what make it traumatic and capable of provoking reactions of repudiation and the various forms of arrested development that can result from such repudiation.

During the decade since 1995, this conception of adolescence as the fulfillment and repetition of infancy has been modified by authors focusing on the specificity of this stage of life. The process of mourning becomes especially important. Anna Freud was the first to draw attention to the similarity of adolescence, emotional disappointments, and periods of mourning. The adolescent libido must detach itself from the parents so it can focus on new objects, and this results in mourning for the nursing mother and the infant body. During this interval between old and new investments, the unattached libido searches for new objects to invest in and returns to the adolescent ego, where it leads to the narcissistic inflation and grandiose fantasies characteristic of this age. Moroseness, biliousness, moments of uncertainty, even depersonalization and periods of depression are signs of the more or less durable vacuity of libido investment.

Can adolescence be better understood with respect to a past that is repeated or fulfilled, or a future to

which it will be subordinated and that will confer subsequent meaning to it? Or should we rather see it as an essential stage in development that can be reduced neither to what came before nor to what will follow? Does adolescence have an identity of its own, such that the nature of the changes that affect it imprint a specific mark on the evolution and destiny of the subject? If so, what is the nature of these changes, and how can they influence the subject’s course of development?

The most specific change in adolescence is navigating between the dual tasks of integrating a genitally mature body in society and partaking an autonomy that appears in this period in life. The effects of puberty on the body modify the adolescent’s relationship to his drives by giving him, along with a pubescent body, a means to discharge them. The adolescent needs autonomy—a distance from earlier objects of attachment, the parents. Autonomy in turn challenges the narcissistic assumptions of the subject and serves to reveal the quality of his internal world, the (secure or insecure) character of his attachments, and the ability of his ego to take control of functions that have until then devolved to his parents. The connections between internal and external reality are questioned and thus undergo important changes.

Adolescence thus corresponds to a need for psychic work in the development of every human being—a need that every individual is confronted with and for which every society must provide a solution. Here we see with particular acuity what Freud defined as a drive, namely a need for work by the psyche owing to its bond to the somatic. Indeed, the origin of this excess of psychic work typical of adolescence is the extra somatic development associated with puberty, but with the particular features that deferred action confer upon it. For the adolescent, the image he constructed of himself during childhood vacillates while he awaits a new cultural and symbolic status. Thus, aside from the conflicts of identification and the Oedipus complex, the most profound strata of personality and the self in its initial period of constitution are summoned and tested during adolescence.

There is indeed a crisis of adolescence in the sense that, psychically, the subject will be different after puberty. But this crisis always has a form and conclusion generally conditioned by culture and the familial systems to which each of us belongs. Consequently, an internal crisis of the psyche is consubstantial with the somatic impact puberty has on the psyche and with



the psychosocial impact of adolescent autonomy, but the external expression of this crisis largely depends on events that transpired during infancy and on the nature and quality of the current social environment.

The family is capable of promoting or interfering with this process. A kind of resonance often occurs between the midlife crisis that parents experience when their children reach adolescence and the problems faced by the adolescent. Such resonance adds to the confusion between generations and blurs limits on behavior for the adolescent. Similar resonance occurs when the adolescent actualizes the parents' unresolved conflicts with their own parents that they then reenact with their children. Such resonance amplifies conflicts and contributes to the adolescent's feeling of being misunderstood and subject to foreign forces.

External reality appears as a possible mediator capable of reinforcing or weakening the structures of the psychic apparatus. Its essential role is to make the growth of object investments associated with the two-fold phenomenon of separation from infantile objects and the resumption of processes of identification narcissistically acceptable. External objects, especially parents, can serve as mediators for internal objects, their concrete attitudes helping to correct whatever is terrifying or constricting in the internal objects, and thus helping to nuance and humanize the superego and ego ideal. They can also create the conditions for pleasure that can be used and exchanged and that authorizes the adolescent libidinally to reinvest object ties without having to become conscious of the importance of those objects. This resembles the conditions typical of the transitional objects of early childhood, or what some authors prefer to call "transformational objects." Because of their diversity, these external objects, coupled with visual reminders of the difference between the sexes, may strengthen a third function that vacillates and is regression and lack of differentiation.

What is true of parents is also true of the mediator figures provided by society: teachers, social workers, friends, ideologies, and religions. These can be temporary supports, offering adolescents a foothold that preserves their need for investment in a narcissistically acceptable self-image before they discover their own way. As with religion and some ideologies, these supports can also provide the adolescent with an outlet that hides discoveries of infantile fusional needs that subjugate the individual to an undifferentiated totalitarian relation.

If the needs for psychic transformation appear to be inherent in adolescence, the forms assumed by these changes are particularly dependent on how society operates. Thus, in this connection, there is an emphasis the role of the generational crisis and modern forms of revolt against the father. We can also raise questions about the impact of a transition from a society structured around precise operational rules and explicit prohibitions to a more liberal society. This transition favors a transition from an adolescence dominated by the problematic of conflicts associated with prohibitions and their possible transgression to an adulthood dominated by the problematic of fear of dissolution of those ties and of expression of needs of dependence. Prohibitions, though they can lead to revolt, lead to misunderstanding the need of dependence. Freedom, together with the requirements of performance and success, brings to light narcissistic uncertainties and needs for completeness.

PHILIPPE JEAMMET

See also: Adolescence.

### Bibliography

- Debesse, Maurice. (1941). *La crise d'originalité juvénile*. Paris: Presses Universitaires de France.
- Freud, Sigmund. (1900). The interpretation of dreams (Parts 1–2). *SE*, 4: 1–338; 5: 339–625.
- (1905). Three essays on the theory of sexuality. *SE*, 7: 123–243.
- Freud, Sigmund, and Breuer, Josef. (1895d [1893–95]). Studies on hysteria. *SE*, 2: 1–310.
- Jeammet, Philippe. (1994). Adolescence et processus de changement. In Daniel Widlöcher (Ed.), *Traité de psychopathologie* (pp. 687–726). Paris: Presses Universitaires de France.
- Laufer, Moses, and Laufer, M. Eglé. (1984). *Adolescence and developmental breakdown: A psychoanalytic view*. New Haven: Yale University Press.

### Further Reading

- Menninger, Walter W. (1988). Introduction: the crises of adolescence and aging. *Bulletin of the Menninger Clinic*, 52, 190–197.

---

## ADORNO, THEODOR AND FREUD

Any serious history of the Frankfurt School requires that a major role be accorded to Freud's significance in the

development of critical theory. Freudian thought played a central role in the works of Herbert Marcuse, Max Horkheimer, and, more recently, Jürgen Habermas. But none was more influenced by Freud than Theodor Adorno. In a sense, Adorno was an orthodox Freudian. He supported instinct theory (*Triebtheorie*), in contrast with the “revisionism” of Erich Fromm and Karen Horney, who faulted Freud for biological determinism, and in contrast with the sociological reductionism of Talcott Parsons, who wanted to integrate psychoanalysis into a more comprehensive theory of “social action.” Yet Adorno also parted ways from Freud in his belief that Freud tended to collapse external reality into a psychological universe. Even here, however, Adorno remained surprisingly well disposed toward Freud. Though he viewed Freud’s psychological atomism as mistaken because it minimized the importance of social factors, he considered it to be profoundly correct in that, under advanced capitalism, humans are reduced to isolated monads. In a sense, Freud was right even when he was wrong.

Though Marxism too played a crucial role in the development of Adorno’s thought, the main features of his version of critical theory can be said to be Freudian. Adorno did not lose sight of the fact that every object is the product of history and that the subject plays an active role in the acquisition of knowledge. This idea clearly fits well with psychoanalytic thought, which, while inheriting some principles of nineteenth-century empiricism and materialism, is fully hermeneutic in its clinical application and adheres to a nonpositivist conception of truth.

Far from presupposing a neutral, knowing, analyst, psychoanalysis requires the analyst actively to intervene and holds that objectivity is attainable only intersubjectively. Similarly, in the methodology of critical theory, the object is observed from an immanent, interior viewpoint, not from a transcendent perspective like the one adopted by the sociology of knowledge. This is precisely the point of view of psychoanalysis, which aims to make conscious the social determinants of individual pathologies by seeking those determinants not in the external world but rather through the imprint that they leave on the mental and emotional life of the patient.

Finally, a fundamental principle of critical theory is the principle of nonidentity—the view that, under present social conditions, no synthesis can unite sub-

ject and object, particular and universal, the individual’s aspirations to happiness and the imperatives of society. This principle of critical theory closely corresponds with Freud’s idea of an insurmountable conflict between desire and fulfillment, between the demands of instinct and the requirements of civilization. The foregoing affinities show that both Adorno’s critique of culture and his theory of personality owe much to Freudian thought.

Adorno’s critique was based on two psychoanalytic categories: identification and projection. Through identification, the individual internalizes the father, his symbolic substitutes, and, in the final analysis, society as a whole. In projection, the individual projects onto the external world impulses, emotions, and ideas. Neither of these mechanisms is intrinsically pathological. Identification is essential for an individual’s social integration; projection is necessary for the individual’s acquisition of knowledge, which arises from assimilating sense data, analyzing it through internal reflection, and transforming it into ideas about external reality.

However, all of this changes in the present state of capitalism or, more generally, in industrialized society. Whereas in earlier stages of social development, identification allowed individuals a margin of autonomy, inasmuch as socialization was achieved through the family and could produce free individuals, now it is directly accomplished by the social order, by industrialized society, and in accordance with other specialized demands aimed at producing social consensus.

Similarly, Projection has ceased to be an instrument for producing useful knowledge of reality because the same demands for conformity that directly subordinate the individual to the group have rendered superfluous the process of inner reflection through which facts about the world are processed. In consequence, modern humans project only resentment, destructive instincts, and inner emptiness, converting the world into a paranoid social order filled with hostile institutions.

In short, in the case of genuine identification, the subject internalizes a social model that creates greater autonomy, while with false identification, typical of advanced capitalism, individuality is effaced. Likewise, with real projection, the subject can acquire knowledge about reality by processing sense data, while with false projection, the subject perceives a illusory reality portraying his inner emptiness.

Another field that Adorno investigated with help from Freud was the theory of personality. He elaborated his ideas in a work he authored with several colleagues, *The Authoritarian Personality* (1950), an empirical study that attempted to explain the correlation between personality structure and viewpoints concerning social and political problems. The hypothesis was that subjects with an authoritarian personality structure, as measured using psychoanalytic variables, are more likely to profess reactionary political ideas, while nonauthoritarian subjects are more likely to hold liberal views. To the great surprise of the authors, the expected correlation did not materialize, because many authoritarian individuals were liberal and many nonauthoritarian individuals were reactionary.

Adorno proposed two possible explanations for this anomaly. One was that the sociological environment, a “general cultural environment,” shapes everyone in it, independently of individual personality structures, requiring all to embrace the values of the established order. Adorno’s other explanation, the orthodox psychoanalytic perspective, was that liberal or conservative authoritarian individuals imperfectly identify with their fathers, in consequence of which their behavior is at once submissive yet rebellious, obedient to authority yet hostile. One is left with either false liberals, whose progressive views are negated by deep-seated destructive tendencies, or faithless conservatives, who are intrinsically fascist rather than genuine supporters of the status quo, which in American society includes freedom of choice and equal opportunity. The reverse is true of nonauthoritarian individuals. In these individuals, the oedipal conflict resulted in an accommodating attitude toward authority. These individuals are liberal in aspiring to authentic change yet conservative in wanting to defend what is best in the American tradition.

The two components of Adorno’s theory—the critique of culture and the theory of personality—are transparently complementary. His critique of culture focused on advanced, postindustrial society and its mechanisms for stabilizing and reproducing itself on the cultural and psychological levels. Similarly, at the core of his theory of personality is the kind of human being that postindustrial society needs and creates in order to perpetuate itself. Adorno linked these components using conceptual tools borrowed from Freud. Perhaps in the early twenty-first century, with Adorno’s exclusive reference to Freud, such analyses appear anachronistic in terms of contemporary analytic thought, but even so they show the impressive and

continual fecundity of psychoanalysis for better understanding modern and postmodern society.

SERGIO PAULO ROUANET

*See also:* Marcuse, Herbert; Marxism and psychoanalysis; Politics and psychoanalysis

### **Bibliography**

Adorno, Theodor. (1973). *Negative dialectics* (E. B. Ashton, Trans.). New York: Seabury Press.

Adorno, Theodor, with Frankel-Brunswick, Else, Levinson, Daniel J.; and Sanford, R. Nevitt. (1950). *The authoritarian personality*. New York: Harper and Row.

Horkheimer, Max, and Adorno, Theodor. (1972). *Dialectic of enlightenment* (John Cumming, Trans.). New York: Continuum.

---

**AFTERWARDNESS.** *See* Deferred action

---

### **AGENCY**

The term “agency” denotes a part of the psychic apparatus that functions as a substructure governed by its own laws, but that is coordinated with the other parts.

In Freud’s work this term first appeared in chapter VII of *The Interpretation of Dreams* (1900a), as a synonym or near-synonym for the term *system*, which he had been using for several years: “Accordingly, we will picture the mental apparatus as a compound instrument, to the components of which we will give the name of ‘agencies’ or (for the sake of greater clarity) ‘systems.’” (pp. 536–537) The term *apparatus*, used in a sense that never changed in Freud’s work, explicitly gives the psyche a status comparable to that of the major organic systems (respiratory, circulatory, etc.).

An agency is thus a functional sub-whole, or, in modern terms, a substructure within an encompassing structure. This idea clearly came from Freud’s extensive prior work in neurophysiology and then neurology. If Freud suggested in this text that the term *system* was “clearer,” this is doubtless because it was more familiar to him. Indeed, he had been using it for years, particularly in “Project for a Scientific Psychology” (1950c [1895]), to evoke this type of functional groupings

within the nervous system, whose workings he was trying to conceptualize at the time. He posited these systems as “producing” perception, consciousness, memory, and so forth. In the passage cited from *The Interpretation of Dreams*, he thus distinguished the agencies, or systems, of memory and perception (envisioned as being mutually exclusive), and censorship, but also the agencies that comprise his first topography: the unconscious, the preconscious, and consciousness (or perception-consciousness).

In Freud’s writings from that point on, the terms *agency* and *system* remained close in meaning. However, *system* tended to be reserved for topographical distinctions, while *agency* was used more broadly to refer to an organization being considered from the topographic, dynamic, and economic viewpoints in combination. It is because they are considered in this way that the id, the ego, and the superego of the structural theory are referred to as agencies rather than as systems. Freud tended to posit the agencies as being exclusive: A single phenomenon cannot at the same time belong to the realm of the id and that of the ego, for example. By virtue of this very fact, when Freud at the end of his life came to see the opposition between conscious and unconscious as being simply a difference in “quality” of certain psychic processes—as described in “An Outline of Psycho-Analysis” (1940a [1938])—those two terms were no longer considered as denoting agencies.

In the conceptual architecture of metapsychology, the term *agency* is therefore situated at a level that makes its definition somewhat uncertain. Béla Grunberger thus generated heated controversy when he proposed, in *Narcissism: Psychoanalytic Essays* (1971/1979), to consider narcissism as an agency having the same status as the id, the ego, and the superego. Similar controversies arose over the concept of the self as developed by Heinz Kohut, for example.

ROGER PERRON

*See also:* System/systemic.

### Bibliography

- Freud, Sigmund. (1900a). The interpretation of dreams. Part I, *SE*, 4: 1–338; Part II, *SE*, 5: 339–625.
- . (1940a [1938]). An outline of psycho-analysis. *SE*, 23: 139–207.

———. (1950c [1895]). Project for a scientific psychology. *SE*, 1: 281–387.

Grunberger, Béla. (1979). *Narcissism: psychoanalytic essays*. (Joyce S. Diamanti, Trans.). New York: International Universities Press. (Original work published 1971)

### Further Reading

Morrison, K. (1999). Agency, ontology, & analysis: R. Schaffer’s hermeneutic conflict. *Psychoanalysis and Contemporary Thought*, 22, 203–220.

---

## AGGRESSIVENESS/AGGRESSION

In the strict sense of the term, aggressiveness corresponds to certain fantasies and behaviors that Freud discovered in the clinical context, but he hesitated at first to give the term a definition that met the requirements of his own subsequent metapsychological signposts. Only after having shown the importance of ambivalence in the transference (Freud, 1912b) was he in a position to think of aggressiveness as a common relational occurrence, but one without a unique or even homogeneous origin. Afterward, his position never changed: he always regarded aggressiveness as the manifestation in fantasy or symptoms of a combination of hostile and erotic affective currents.

In 1900 Freud without hesitation connected aggressiveness to sadism. In 1905 he added a connection to masochism, adopting the position of Joseph Breuer. For Freud, the masculine position in sex led to a degree of sadistic activity, while the feminine position favored masochistic passivity. By 1924 this latter view led to the hypothesis of a specifically feminine masochism. However, Freud moderated this preliminary opinion in a note added to his *Three Essays on the Theory of Sexuality* (1905d) in 1915 after he made the distinction between a triangular genital position and the phallic-narcissistic position, limited to existential conflicts between strong and weak.

In 1908 Freud further clarified aggressiveness with his conception of bisexuality. Moreover, Freud (1914c) was careful to make clear that he reproached Alfred Adler for not having taken into account the libidinal satisfaction linked to aggressiveness, even though it now seems obvious that Adler’s idea was really more about primitive violence than aggressiveness, which, by its nature, appears after sexualization. Thoughts or

behaviors put into motion by aggressiveness require the person to have an imagination capable of integrating a certain level of ambivalence, while the archaic functioning of violence described by Karl Abraham is of a preambivalent nature and involves a more primitive brutality and violence.

The first shift, in 1914, in Freud's theories involving drives, objects, aims, and the particular nature of eroticization had an irreversible effect on his view of the relationship between aggressiveness and narcissism. Narcissistic objects result from primary identifications and defensive violence, while with ego objects, ambivalence causes the person to oscillate between love and its equally eroticized opposites: aggressiveness, hate, and sadism.

In the case of the "Wolf Man" (1918b), as in the case of "little Hans" (1909b), Freud connected a child's early aggressive manifestations with early attempts at seduction. In *The Ego and the Id* (1923b), Freud described how in authentic aggression, eroticization is responsible for modifying the nature of primitive hostility, just as the need for tenderness replaces the need for mastery. In 1925 Freud became interested in the narcissistic exhibitionism that precedes aggressiveness in infantile fantasy. The overly precocious genital quality that Freud attributed to the narcissistic, imaginary phallus by sometimes confusing it with the penis, the real sexual organ specific to the boy, makes it difficult to give a more complete description of the genital specificity of aggressiveness. In contrast, it is easier to describe the early narcissistic forms of hostility that occur prior to a more commingled (and thus ambivalent) manifestation of the two great strains of the drives: sexuality and self-preservation.

Freud did not hesitate, in his theoretical shift of 1932, twelve years after the shift of 1920, to return to the principles of the first theory of the drives by opposing to the libidinal drives the primitive instincts of self-preservation, from which he then derived aggressiveness (1933a). In 1930 he made clear that he discerned in the psyche of the child a brutal original energy that would soon be rapidly sexualized and bring forth aggressiveness, hate, and sadism. Oral and anal metaphors thus came to illustrate this two-stage view of the origin of aggression.

Melanie Klein and her followers insisted on the presence of a precocious affective interaction, one teeming from the first with hostility and mistrust between

the child and its environment and easily recognized in clinical practice. An illustration of this hypothesis is the notion of "projective identification." Proponents of these views have certainly recognized clinically what derives from a violent instinct of self-preservation and what belongs to an already object-related libidinalized aggression, even though they imperfectly distinguish between the two.

The distinction between the dynamics of primitive instinctual violence and the dynamics of drive pressures giving way to aggressive thoughts or behaviors can be understood at three levels: the level of the specific origins of drives, the level of the particular history of the psychogenetic processes in question, and the level of Freudian metapsychology.

Freud never changed his view on the origin of fantasies or behaviors emanating from aggression. What is involved is a particular form of the sexual drives deflected from their primary aim and entangled with the brutal, hostile primitive impulses. These primitive impulses thus lose their initial, purely self-protective aim. The conjunction of these two fundamental instinctual currents in the service of aggressiveness thus constitutes a kind of layering of the drives. Such a layering does not exist in the infant's original genetic equipment in its pure state, though violent instincts, just like the sexual drives, exist in a pure and specifiable state in the basic affective equipment of the newborn.

From the psychogenetic point of view, psychoanalytic research has gradually enriched the study of affective development beginning at the pre-oedipal and pregenital periods. These studies have further clarified and developed Freud's views of the origins and organization of narcissism. The (primary and secondary) narcissistic stages necessarily involve some sort of objects, but Freud clearly demonstrated that narcissistic objects, focused primarily on a relationship of power, differ radically from oedipal objects, which involve dissimilarity, equality, and complementarity. For aggressiveness to come into play, an object relationship must develop out of an organized fantasy arising from the Oedipus complex and genitality. Aggressiveness is a secondary development, as Freud conceived of it.

From the point of view of conflicts, the classical Freudian notion topographically places aggressiveness within the framework of the activities of the ego. From

an economic point of view, aggressiveness is conceived as arising in connection with an already genitalized object. Finally, from a dynamic point of view, aggressiveness occurs when the sexual drives become bound to brutal, primitive impulses. In this way, the sexual drive tinges the brutal impulses with pleasure, with the result that they become sexually perverse and destructive. In a less pathologic course that arises with the start of the Oedipus complex and is finalized during adolescence, violent primitive impulses reinforce the sexual drives in their appropriate purpose in the service of love and creativity. Such is how Freud described aggressiveness in his elaboration of the concept of *anaclysis*.

Aggressive fantasies can involve a simultaneous libidinal satisfaction in attacking an object who represents (consciously or unconsciously) an oedipal rival, whereas in narcissistic conditions, the resulting violent primitive anger (rage) seeks to protect the self without taking into account the injuries inflicted on one who is experienced simply as an external threat and not as a genuine object (other). Confusion in this regard can be avoided through the use of transference and counter-transference.

The notion of aggression directed at the self, so often invoked in clinical practice, implies that an already eroticized sadism is turned back upon the subject, and not simply that partial or full desexualization leads to an act of self-punishment.

JEAN BERGERET

*See also:* Adler, Alfred; Anal-sadistic stage; Essential depression; Conflict; Cruelty; Death instinct (Thanatos); Depressive position; Envy; Narcissistic rage; Oral-sadistic stage; Paranoid position; Phobia of committing impulsive acts; Sadism; Sadomasochism; Splitting of the object; Sublimation; Turning around upon the subject's own self; Violence, instinct of.

### **Bibliography**

- Bergeret, Jean. (1984). *La violence fondamentale*. Paris: Dunod.
- Diatkine, René, (1966). Intervention au 7e séminaire de perfectionnement. *Revue française de psychanalyse*, 30 (3), pp. 324–344.
- Freud, Sigmund. (1900a). The interpretation of dreams. *SE*, 4: 1–338; 5: 339–625.
- . (1905d). Three essays on the theory of sexuality. *SE*, 7: 123–243.

- . (1908). Hysterical phantasies and their relation to bisexuality. *SE*, 9: 156–166.
- . (1909b). Analysis of a phobia in a five-year-old boy. *SE*, 10: 1–149.
- . (1912b). The dynamics of transference. *SE*, 12: 97–108.
- . (1914c). On narcissism: An introduction. *SE*, 14: 67–102.
- . (1918b). From the history of an infantile neurosis. *SE*, 17: 1–122.
- . (1920g). Beyond the pleasure principle. *SE*, 18: 1–64.
- . (1923b). The ego and the id. *SE*, 19: 1–66.
- . (1924c). The economic problem of masochism. *SE*, 19: 155–170.
- . (1933a). New introductory lectures on psychoanalysis. *SE*, 22: 1–182.

### **Further Reading**

- Gray, Paul. (2000). Analysis of conflicted drive derivatives of aggression. *Journal of the American Psychoanalytic Association*, 48, 219–236.
- Fonagy, Peter, et. Al. (1993). Aggression and the psychological self. *International Journal of Psychoanalysis*, 74, 471–486.
- Fosshage, James L. (1998). On aggression: its forms and functions. *Psychoanalytical Inquiry*, 18, 45–54.
- Kernberg, Otto. (1992). *Aggression in personality disorders and perversions*, New Haven/London: Yale University Press.
- Mitchell, Stephen. (1998). Aggression and the endangered self. *Psychoanalytical Inquiry*, 18, 21–30.

---

## **AICHHORN, AUGUST (1878–1949)**

An Austrian educator with an interest in psychoanalysis, the pioneer of a new approach to reeducating problem children, August Aichhorn was born July 27, 1878, in Vienna, Austria, where he spent his entire life, and died October 13, 1949. He was raised, along with a twin brother who died when Aichhorn was 19, in a Catholic family of modest means. He became a teacher and continued his studies at the Technische Hochschule of Vienna.

From 1908 to 1918 he was in charge of managing homes for boys in the Austrian capital. In 1918 he was

made responsible for setting up an educational center for delinquent children in an unused refugee camp. Convinced that the suppression then commonly practiced was not the right approach, and disappointed by the kinds of psychological training taught at the university, he introduced unorthodox methods, based on “warm sympathy with the fate of those unfortunates and was correctly guided by an intuitive perception of their mental needs” (Freud, 1925f). His educational success caught the attention of Anna Freud, and it is through her that he discovered psychoanalysis when he was already past forty. He undertook an analysis with Paul Federn and, in 1922, became a member of the Vienna Psychoanalytic Association. When his experiment in reeducation came to an end, Aichhorn created, in 1923, educational centers that focused on psychoanalysis in each of Vienna’s fourteen districts. He worked in the centers, always at his teacher’s salary, until his retirement in 1930.

Along with his responsibilities as a re-educator, he expended tremendous energy in teaching and training. The conferences at which he discussed his original approach to problem adolescents are collected in his book *Wayward Youth* (1925), with a preface by Sigmund Freud. The book was an international success. He was invited to Zurich, Basel, Bern, Prague, Berlin, Stuttgart, and Lausanne. He collaborated in the *Revue de pédagogie psychanalytique* (Review of Psychoanalytic Pedagogy), which he co-edited from 1932 on. Between 1931 and 1932 he directed the small school created by Dorothy Burlingham. After Freud and his followers fled the city, Aichhorn continued to train doctors and psychologists in psychoanalysis and to organize seminars for education and guidance counselors. Made president of the new Vienna Psychoanalytic Association in 1946, he continued his work among educators, whom he exposed to the importance of psychoanalytic training.

Aichhorn opened a new field of activity in psychoanalysis—social work. He radically renewed the approach to “abandoned” youth, showing that asocial phenomena—latent or manifest—had their origin in the severe lack of social and emotional support experienced during childhood. His ideas on how to use transference as a therapeutic tool, on the importance of the individual, both the educator and the delinquent, and on the necessity of giving marginalized youth a sense of responsibility to help reintegrate them socially are still relevant. “Psycho-analysis could teach

him little that was new of a practical kind, but it brought him a clear theoretical insight into the justification of his way of acting and put him in a position to explain its basis to other people” (Freud, 1925f).

JEANNE MOLL

*See also:* Abandonment; Adolescence; Austria; Burlingham-Tiffany, Dorothy; Puberty; Wiener psychoanalytische Vereinigung; *Zeitschrift für psychoanalytische Pädagogik*.

### **Bibliography**

- Aichhorn, August. (1951). *Wayward youth*. London: Imago Publishing Company.
- Cifali, Mireille, and Moll, Jeanne. (1985). *Pédagogie et Psychanalyse*. Paris: Dunod.
- Freud, Sigmund. (1925f [1951]). Preface to *Wayward youth*. London: Imago Publishing Company.

---

## **AIMÉE, CASE OF**

The full title of the doctoral thesis that signaled Jacques Lacan’s entry into psychiatry was *De la psychose paranoïaque dans ses rapports avec la personnalité* (On paranoid psychosis as it relates to the personality). The work was dated September 7, 1932, when Lacan was thirty-one years old.

Readers of the work were uniformly impressed with the breadth of scientific learning that Lacan displayed. To Georges Heuyer, who had doubts about the sheer quantity of bibliographical references, Lacan responded that he had, in fact, read them all. Furthermore, Lacan claimed to have personally evaluated about forty cases. And his familiarity with German texts clearly distinguished his scholarship from the chauvinism characteristic of the two great schools of psychiatry of the time. The French school was his model because of the high quality of its observation and because of its elegance and precision. But the Germans supplied Lacan with the doctrinal authority required by his goal of methodological synthesis.

“Then came Kraepelin” (Lacan, 1932, p. 23). Emil Kraepelin succeeded in imposing differential diagnoses in the field of the psychoses, where previously the category of paranoia had been extended to every kind of delusion and cognitive disorder in a way clearly contradicted by observation, despite the fact that paranoia

was defined very narrowly. Lacan wrote in glowing terms of Johannes Lange, coauthor of the 1927 edition of Kraepelin's *Manual of Psychiatry*, whose study of eighty-one cases noted that classical paranoia was extremely rare, and assigned the curable cases to the category delineated by Kraepelin. As for "genuine paranoia," the question was whether it could be acute, whether remissions were possible. This was a question that Lacan asked from the outset (1932) and that would still preoccupy him twenty-five years later in "On a Question Prior to Any Possible Treatment of Psychosis" (1959/2004). For Lacan, the work of Robert Gaupp supplied an affirmative answer to this question. In short, Lacan endorsed Kraepelin's inclination toward a psychogenetic conception of paranoia, and what Lacan called "psychogeny" became a main theme of his thesis. Hence Lacan's harsh criticism of organicism, the constitutional theory, and the ideology of degeneracy—all then still prevalent in French psychiatry.

To stymie these tendencies, Lacan chose to speak of "personality." To solidify this notion, he drew upon Ernst Kretschmer, Pierre Janet, Karl Jaspers, and, finally, Eugen Bleuler. Bleuler and the Zurich school were Lacan's main route into psychoanalysis from the psychiatric study of the psychoses. Lacan sought to relate mental disturbances to personality, as Janet did, and, like Kretschmer, to explain them in terms of the individual's history and "experience" (*Erlebnis*) (1932, p. 92), with "its social and ethical stresses," rather than by evoking "congenital defects" (1932, p. 243). All this implied a "comprehensive" approach to psychotics consonant with the phenomenology of Jaspers. For this reason, Lacan enlisted the masters of psychiatry and psychopathology in support the open-minded approach to mental illness characteristic of his friends at the journal *L'évolution psychiatrique*.

Lacan argued that pathological manifestations in psychosis were "total vital responses," which, as "functions of the personality," maintained meaningful connections with the human community (1932, p. 247). In short, they were meaningful—a realization that defined the young Lacan's approach and influenced the choice of his inaugural case, that of "Aimée."

Aimée was a thirty-eight-year-old woman who, with "eyes filled with the fires of hate" (1932, p. 153), had tried to stab the celebrated actress Huguette Duflos. As a result of this attempted "magnicide" on April 18, 1931, she was immediately imprisoned.

Lacan began to see her one month later at Sainte-Anne Hospital. He reconstructed "almost the full gamut of paranoid themes" (1932, p. 158): persecution, jealousy, and prejudice for the most part, themes of grandeur centered chiefly on dreams of escape and a reformatory idealism, along with traces of erotomania. Her cognitive functions were unaffected. To this classic picture, which Lacan established by means of thorough biographical inquiry, Lacan added what he considered a decisive consideration: after twenty days of incarceration, the patient's delusional state diminished dramatically. This development Lacan viewed as evidence of the acute nature of her paranoia. Connecting Aimée's criminal act with this remission, he set out to discover the meaning of her pathology, and with this in mind he proposed a new diagnostic category: "self-punishment paranoia."

Aimée also aroused Lacan's curiosity because of her attempts at writing. Lacan had already evinced an interest in the writing of psychotics, and in his thesis (1932) he published selected passages from "Aimée"—the name being that of the heroine of the patient's projected novel. Aimée's writings and the sensational aspects her case brought Lacan's work to the attention of a public well beyond psychiatry. The spirit of the times saw links among art, madness, and psychoanalysis. The dreams related by André Breton in *Communicating Vessels* date from 1931, and his exchange of letters with Freud, which followed the publication of this book, date from 1932. René Crevel, Paul Éluard, Salvador Dalí, Joë Bousquet all echoed Lacan's thesis. In 1933, in the first issue of the Surrealist magazine *Minotaure*, Dalí cited "Jacques Lacan's admirable thesis" and praised the thesis of "the paranoiac mechanism as the force and power acting at the very root of the phenomenon of personality." Lacan took pride in this acknowledgment. In his *Écrits* (1966), he described his thesis as merely an introduction to "paranoiac knowledge" (p. 65), an unmistakable allusion to Dalí's "paranoiac-critical method." He never revised this attitude: as late as December 16, 1975, he declared, "Paranoid psychosis and personality have no relationship because they are one and the same thing."

Left-wing philosophers likewise fell under the spell of Lacan's book. Paul Nizan, a careful reader of Jaspers, published a summary of it the communist daily *L'humanité* for February 10, 1933; Lacan's talk of a "concrete" psychology related to "social reality" sufficed to open that particular door. Jean Bernier, in *La*



*critique social*, a journal to the left of the Communist Party, offered a brilliant reading of Lacan's thesis, despite being marred by misunderstandings of psychoanalysis so common among revolutionary critics.

Lacan's doctoral thesis was significant in another way too: it was his declaration of allegiance to psychoanalysis. He undertook a personal analysis and trained under the auspices of the recently established Société psychanalytique de Paris (Paris Psychoanalytic Society). In his thesis, he hailed "the scientific import of Freudian doctrine," the only theory capable of apprehending the "true nature of pathology," as opposed to other methods, which, despite their "very valuable observational syntheses," failed to clear up uncertainties (1932, p. 255). Lacan's study of the case of Aimée and his overall view of the psychoses were thoroughly imbued with Freudian teachings. Thus he saw the psychogenesis of Aimée's pathology in light of the theory of the development of the libido, as rounded out a few years earlier by Karl Abraham (1924/1927). And he understood delusion as the unconscious offering itself to the understanding of consciousness. "Ça joue au clair," Lacan reiterated in his seminar on the psychoses (1981/1993, session of 25 January 1956).

For Lacan, the notion of personality certainly implied "a conception of oneself" (1932, p. 42), but in his view this conception was based on "ideal" images brought up into consciousness. Under the acknowledged influence of Angelo Hesnard and René Laforgue's report to the Fifth Conference of French-Speaking Psychoanalysts in June 1930, Lacan advanced his hypothesis of psychosis as "self-punishment" under the influence of the superego. He suggested that a nosological distinction be drawn for cases where an element of hate and a "combative attitude" turn back upon the subject in the shape of self-accusation and self-depreciation, and concluded by proposing the category of "psychoses of the super-ego," to include contentious and self-punishing forms of paranoia (1932, p. 338).

The most striking aspect of Lacan's thesis, in the context of the time, was the evidence it offered of his solid Freudian grounding, gleaned in part, no doubt, from his translation into French, in that same year of 1932, of Freud's paper "Some Neurotic Mechanisms in Jealousy, Paranoia, and Homosexuality" (1922b [1921]). What Lacan drew from this important work underlay his assertion that "Aimée's entire delusion"

could "be understood as an increasingly centrifugal displacement of a hate whose direct object she wished to misapprehend" (1932, p. 282). At the beginning of his discussion, Lacan derived a general proposition from the same source: "The developmental distance, according to Freud, that separates the homosexual drive, the cause of traumatic repression, from the point of narcissistic fixation, which reveals a completed regression, is a measure of the seriousness of the psychosis in any given case" (1932, p. 262).

The case of Aimée continued to play a part in Lacan's life. For one, he had good cause to remember it when, years later, Aimée turned out to be the mother of one of his patients, the psychoanalyst Didier Anzieu. Furthermore, the themes explored in *De la psychose paranoïaque* continued to preoccupy him in his later work. Most significantly, his resolutely psychoanalytic approach to the psychoses was confirmed by his defining work of the 1950s (1993, 2004), whose great theoretical import was rivaled only by what he called "fidelity to the formal envelope of the symptom" (1966, p. 66). This remark does far more than endorse the precepts of a grand clinical tradition; it distills certain constants of Lacan's thinking. As he adds in the same passage, the formal envelope of the symptom may stretch to a "limit where it reverses direction and becomes creative." This was a crucial issue for Lacan throughout his life, and in many different ways. The culmination of this concern was his engagement with the work of James Joyce, which informed his seminar of 1975–1976 on the "sinthome" (1976–1977). On the same page of *Écrits* (p. 66), Lacan, reviewing his own past itinerary, described what might be considered the function of the symptom: to keep up, despite the ever-present risk of slipping, with what he called "confronting the abyss." Psychosis exemplified such confrontation, which was why Lacan returned here to how "passing to the act" may serve to "fan the fire" of delusion—an original theme explored in his thesis. How such acts relate to literary creation, the function of the symptom, and passing to the act were thus just so many issues first broached in the case of Aimée.

BERNARD TOBOUL

See also: Anzieu, Didier; Bleuler, Paul Eugen; *Évolution psychiatrique* (I' -) (Developments in Psychiatry); Lacan, Jacques-Marie Émile; Paranoia.

## Bibliography

- Abraham, Karl. (1927). A short study of the development of the libido, viewed in the light of mental disorders. In *Selected Papers of Karl Abraham* (Douglas Bryan and Alix Strachey, Trans.). London: Hogarth Press. (Original work published 1924)
- Allouch, Jean. (1994). *Marguerite, ou l'aimée de Lacan* (rev. ed.). Paris: E.P.E.L.
- Dalí, Salvador. (1933). Le mythe tragique de l'Angéelus de Millet. *Minotaure*, 1.
- Freud, Sigmund. (1922b [1921]). Some neurotic mechanisms in jealousy, paranoia, and homosexuality. *SE*: 18: 221–232.
- Lacan, Jacques. (1932). *De la psychose paranoïaque dans ses rapports avec la personnalité*. Paris: Librairie le François.
- . (1966). *Écrits*. Paris: Seuil.
- . (1976–1977). Le séminaire XXIII, 1975–76: Le sinthome. *Ornicar?* 2–5.
- . (1993). *The seminar of Jacques Lacan*. Book 3: *The psychoses, 1955–1956* (Russell Grigg, Trans.). London: Routledge. (Original work published 1981)
- . (2002). On a question prior to any possible treatment of psychosis. In his *Écrits: A selection* (Bruce Fink, Trans.). New York: Norton. (Original work published 1959)

## AJASE COMPLEX

Heisaku Kosawa visited Sigmund Freud in 1932 and presented this paper on the Ajase complex. The paper was entitled “Two Kinds of Guilt Feelings” and subtitled “The Ajase Complex.”

The Ajase complex is an original theory developed by Kosawa, and subsequently expanded by Keigo Okonogi. Whereas Freud based his Oedipus complex on a Greek tragedy, Kosawa developed his theory on the Ajase complex from stories found in Buddhist scripture. The story of Ajase centers on the Buddhist concept of reincarnation. Well known to the Buddhist world, Ajase's story appears with many variations in the scriptures of ancient India. Kosawa modeled his theory on the version of Ajase story appearing in the *Kanmuryojukyo*, a Buddhist scripture centering on the salvation of the mother.

Ajase was the son of a king in India. His mother, fearing the loss of her youth and beauty, wanted to bear a child so she could retain her status. A prophet

told her that a hermit who lived in the forest would be reborn as the king's son. The queen, however, wanted the child as soon as possible and killed the hermit, who then entered her womb. The child that she bore was named Ajase. Just before being slain, the hermit had told the queen that he would be reborn as her son and curse his father. The queen, fearful of what she had done, tried to abort and kill the baby, but she failed and Ajase survived. When Ajase grew up and learned the secret surrounding his birth, he became angry with the queen and attempted to slay her, but was dissuaded from this act by a minister. At that moment, Ajase was attacked by a severe guilt feeling and became afflicted with a dreadful skin disease characterized by so offensive an odor that no one dared approach him. Only his mother stood by and lovingly nursed him. Despite his mother's devoted care, Ajase did not readily recover. Seeking relief, the queen went to the Buddha and told him of her sufferings. The Buddha's teachings healed her inner conflict, and she returned to continue to care for her Ajase. Eventually, the Prince was cured to become a widely respected ruler.

This is the version of the Ajase story Kosawa wrote in the 1950s, based on the *Kanmuryojukyo*. The themes of the Ajase complex are as follows:

1. A mother's conflict between her wish for a child and an infanticidal wish;
2. Prenatal rancor and matricidal wish in the child, Ajase. According to the parable of reincarnation, Ajase is the reincarnation of a hermit whom his mother had killed. In other words, he hates his mother for having killed him before his birth. Prenatal rancor means hatred for the origin of one's birth. Prenatal rancor led Ajase to try to kill his mother when he learned the origin of his birth;
3. Two kinds of guilt feelings. Ajase was overcome with strong feelings of guilt after attempting to slay his mother, and became afflicted with a terrible, painful skin disease characterized by foul-smelling abscesses. Kosawa called this feeling of guilt “a punitive guilt feeling.” Only his mother's forgiveness and nursing brought him back to health. Kosawa called the feeling of guilt that Ajase experienced “a forgiven guilt feeling.”

KEIGO OKONOJI

*See also:* Complex; Guilt, unconscious sense of; Guilt, feeling of; Wish for a baby.

### **Bibliography**

Kosawa, Heisaku. (1931). Two kinds of guilt feelings. The Ajase complex. *Japanese Journal of Psycho-Analysis*, 11, 1954.

Kosawa, Heisaku. (1935, March–April). Two types of guilt consciousness—Oedipus and Ajase. *Tokyo Journal of Psychoanalysis*, 11.

---

## **ALCHEMY (ANALYTICAL PSYCHOLOGY)**

Alchemy is a philosophical and chemical “opus” with roots in ancient times and branches throughout the world’s cultures. It is both an experimental and symbolic practice, a technical research into the nature of matter, and an imaginal exercise on the spirit of matter and its potential for change. It is also a mythopoeic meditation and a projective method, a moving Rorschach for the practitioner.

Using its experiments as metaphors, it has sought an enlivening elixir, a healing panacea, and the transformation of base metal into gold through release from crude impure ores. This occurs through producing a transmuting agent, itself a transformation from the *prima materia* of the common “philosopher’s stone” into the precious “stone of the philosophers” or “lapis.”

Alchemy posits an original unitary energy which separated in space-time into distinct physical elements, “falling apart” and differentiating in the four directions. Perceived as transmutable through shared qualities or correspondences, these elements could one day be reunited in a reconstituted wholeness. The dicta—“Return to chaos is essential to the work,” “Volatize the fixed and fix the volatile,” and “Dissolve and Coagulate”—express a dialectic process between complements and opposites in analysis and synthesis.

The alchemists might quicken this process through their outer intervention in matter and their interior practice of soul and spirit. The *opus* is the work of persons or couples, whose integration or dissociation are operative. While using common references, it values the individual and dynamic over the collective and dogmatic. Through the interior change of the adept and his *soror mystica* (mystical sister) and the chemical changes

in the “well closed vessel” of the retort, the microcosm and macrocosm affect and reflect each other.

The Freudian psychoanalyst Herbert Silberer first observed the analogy to transference in the conjunctions and confrontations among sulphurs, mercuries, and salts, between the “masculine” and “feminine” matter, called king and queen, sun and moon, gold and silver, day and night, male and female.

Jung cited Silberer in his work on the “*coniunctio*” (conjunction) of transference and countertransference. In alchemy, Jung found a precursor of depth psychotherapy’s dyadic and interactional model. He came to understand the psyche, the unconscious, and depth analysis as alchemical process, the “stone” as transformational consciousness, both a means and the goal of individuation. He also noted alchemical images in modern dreams.

BEVERLEY D. ZABRISKIE

*See also:* Allendy, René Felix Eugène; Archetype (analytical psychology); Goethe and psychoanalysis; Jung, Carl Gustav; Silberer, Herbert; Transference/countertransference (analytical psychology).

### **Bibliography**

Jung, Carl Gustav. (1946). The psychology of the transference. *Collected Works* (Vol. XVI). London: Routledge & Kegan Paul.

———. (1953). *Psychological reflections: An anthology of the writings of C. G. Jung* (J. Jacobi, Ed.). London: Routledge and Kegan Paul.

———. (1955–56). *Mysterium Coniunctionis*. An inquiry into the separation and synthesis of psychic opposites in alchemy. *Collected Works* (Vol. XIV). London: Routledge & Kegan Paul.

---

## **ALCOHOLISM**

Alcoholism is not a psychoanalytic concept. The most rigorous definition, following from the basic notion of dependence, is the one provided by Pierre Fouquet: “An alcoholic is any man or woman who has lost the ability to do without alcohol.” The word “alcoholism” was introduced by the Swedish physician Magnus Huss (1849) and mentioned in France by M. Gabriel (1866) in his medical dissertation. It appears in Freud’s writings prior to 1900 in association with hysteria and hypnosis, as a form of “subjection,” a “morbid habit,”

falling somewhere “between the organic affections and the disorders of the imagination.” Principal occurrences of the word appear in letters to Wilhelm Fliess (especially that of December 22, 1897), in the attached manuscript (Draft H., 1895), and especially in the key text “Sexuality in the Aetiology of the Neuroses” (1898a). “Habit,” Freud writes, “is a mere form of words, without any explanatory value” and “success will only be an apparent one, so long as the physician contents himself with withdrawing the narcotic substance from his patients, without troubling about the source from which their imperative need for it springs” (p. 276).

It was initially believed (Sigmund Freud, Karl Abraham, Sándor Ferenczi) that alcohol does not create symptoms but only promotes them, removing inhibitions, and destroying sublimation. The theory of alcohol addiction (1905d) is summarized in terms of its predominance among men beginning with the onset of puberty; its relationship to sexuality, and latent homosexuality, already identified as narcissistic and specular by Viktor Tausk (1913) and Lou Andreas-Salomé (1912); oral fixation, and autoerotic behavior. Emphasis later focused on the nature of the defensive process, an immediately effective means, but one that is too accessible, which is why it is so dangerous (1930a [1929]). The economic approach to affects was emphasized next—concepts of alexithymia (McDougall, 1978), instinctual discharge by the body (“resomatization of affects”), and acting out (“dispersion,” “destruction of affects,” “acts-symptoms”), depending on the author—all at the expense of psychic elaboration.

Alcohol plays the role of a unique substitute object and a trap, creating a pseudo-reality; the hallucinations associated with delirium tremens cease with the administration of alcohol. The narcissistic problematic (withdrawal) in fact harbors an autoerotic component and gives rise to defenses, barriers, or narcissistic prostheses, such as an overinvestment in work, children, “friends,” etc., and alcohol. The mechanism of splitting into non-alcoholic (common, neurotic) and alcoholic sectors of the ego has denial as its corollary, but it is a denial that does not involve the perception of an external reality (difference of the sexes, castration) but rather the internal perception of the body itself. There exist silent zones, “matrices of painful, deadly territories that threaten the unity of the ego” (Mijolla and Shentoub, 1973). These are the parts of the body that lie outside symbolization and outside language, as described by Jean Clavreul

(1959). For Paul Schilder and Walter Bromberg (1933), alcoholism is accompanied by a regression from castration that leads to bodily fragmentation. The alcoholic short circuit leaves no room for the establishment of loss, the source of desire, but rather establishes an ensemble of needs and repetitive acts that are without meaning. An analogy can be made with pathological games. Shame or opprobrium are distinguished from guilt. The superego of an alcoholic is demanding but “soluble in alcohol” (Simmel, 1930). There is no strong image with which the subject identifies, but identification can occur with someone hated, which can lead to “self-hatred.” The indulgent and demanding mother who creates insecurity is the object of reverse fantasies (idealization).

The symbolism of alcohol is that of vital fluids (blood, “the blood of the vine,” sperm, milk) or destructive humors (urine, feces), of the breast and the penis, good and/or bad. This symbolism is present in all the myths associated with alcohol, from Dionysus to the Eucharist.

The situation in terms of a psychoanalytic classification is still the subject of controversy. It is a narcissistic disorder, closer to manic-depression and paranoia than to neurosis, psychosis, or perversion. Its issues fall within the framework of addiction.

Intolerance to alcohol can be interpreted as a reaction formation to the excitations that alcohol promotes, or to the frequently negative attitudes toward alcoholics, sometimes as extreme as hatred (Winnicott, D. W., 1947), or even to the most primitive issues of the alcoholic that are awakened in the therapist. From the standpoint of treatment, it is a matter of detoxification or social prohibition (1927c)—“Not all men abandon this toxic supplement with the same facility” (1905c), “the only effective remedy is the resolution that draws its strength from a powerful current of the libido”—as opposed to involvement of the superego (1966b [1932]). The effectiveness of temperance movements appear to be associated with libidinal investments “torn from alcohol” and given expression in exhibitionism, or homosexual and narcissistic masochism.

There is a double risk of using the term “alcoholism”: the risk of turning it into a closed and homogenized entity, or of breaking apart the clinical concept, reductively assimilating it to various diagnostic classifications (neurosis, psychosis, perversion—fetishism,

for example—paranoia, manic-depression, psychopathy, etc.). To compound the problem, concepts such as homosexuality, orality, “disappointment,” and “libidinal viscosity,” risk serving as facile or even completely inappropriate explanations.

Freud himself often superimposed the phenomenology of drunkenness and the psychopathology of alcohol addiction, and even considered the relation of the alcoholic to his poison as nonconflictual, “the purest harmony,” and “an example of a happy marriage” (1912d, p. 188). Blind spots with respect to his own relationship to toxic substances (cocaine, tobacco) led him outside the field of psychoanalysis when he postulated a “toxological theory” in psychopathology, which he did not abandon until the *Outline of Psychoanalysis* (Descombey, 1994).

There are a number of concepts related to alcoholism: addiction, alcoholic intoxication, alcoholic delirium and jealousy, delirium tremens (Viktor Tausk’s delirium of action or occupation), alcohol-associated epilepsy. And it can be asked, as Freud asked about psychosis, if the terms “denial” and “repression” have the same meaning with respect to alcoholism as they do for the psychopathology of the neuroses. The same question could also be asked about the familiar use of the concepts of desire and pleasure when it comes to a clinical practice that is situated “beyond the pleasure principle” or within the register of need.

Post-Freudian authors who have done substantive work on alcoholism include James Glover (1938) and the Kleinians Herbert Rosenfeld (1964) (paranoid-schizoid and depressive positions), Sándor Radó (1933) (pharmacothymia, initial anxiety depression, pharmacogenic orgasm, addiction crisis), and Michael Balint (1977) (basic fault). There has also been renewed interest in the subject in the work of the French psychoanalysts Jean Clavreul (1959), Alain de Mijolla and Salem A. Shentoub (1973); the Lacanians François Perrier (1975), Charles Melman (1976), A. Rigaud (1976), M. Lasselin (1979), and F. Gondolo-Calais (1980); as well as Jacques Ascher (1978), Joyce McDougall (1989), M. Monjauze (1991), and Jean-Paul Descombey (1985–1994).

JEAN-PAUL DESCOMBEY

*See also:* Addiction; Dependence; Dipsomania; Indications and contraindications for psychoanalysis for an adult.

### **Bibliography**

- Bromberg, William, and Schilder, Paul. (1933). Alcoholic hallucinations—castration and dismembering motives. *International Journal of Psychoanalysis*, 14, 206–224.
- Clavreul, Jean. (1959). La parole de l’alcoolique. *Psychanalyse*, 5, 257–280.
- Descombey, Jean-Paul. (1985). *Alcoolique, mon frère, toi: l’alcoolisme entre médecine, psychiatrie et psychanalyse*. Toulouse: Privat.
- . (1994). *Précis d’alcoolologie clinique*. Paris: Dunod.
- Freud, Sigmund. (1898a). Sexuality in the aetiology of the neuroses. *SE*, 3: 259–285.
- . (1905d). Three essays on the theory of sexuality. *SE*, 7: 123–243.
- . (1912d). On the universal tendency to debasement in the sphere of love. *SE*, 11; 177–190.
- Huss, Magnus. (1849). *Alcoholismus chronicus eller kronisk alkoholsjukdom*. Stockholm: n.p.
- McDougall, Joyce. (1989). *Theaters of the body: a psychoanalytic approach to psychosomatic illness*. New York: Norton.
- Mijolla, Alain de, and Shentoub, Salem A. (1973). *Pour une psychanalyse de l’alcoolisme*. Paris: Payot.

### **Further Reading**

- Director, L. (2002). Relational psychoanalysis in the treatment of chronic drug & alcohol abuse. *Psychoanalytic Dialogues*, 12, 551–580.

## **ALEXANDER, FRANZ GABRIEL (1891–1964)**

A doctor and psychoanalyst, Franz Gabriel Alexander was born January 22, 1891, in Budapest, and died March 8, 1964, in Palm Springs, California. The son of Bernard Alexander, a Jewish professor of philosophy, Franz Alexander studied medicine in Göttingen and Budapest, and specialized in research on the physiology of the brain. Following the First World War, he moved to Berlin. It was Sigmund Freud who introduced him to psychoanalysis, but he completed his analytic training with Hanns Sachs in Berlin.

In 1921 he became a member of the German Psychoanalytic Society, an assistant at the Berlin Psychoanalytic Institute, and a training analyst. He undertook a reformulation of the study of neuroses in his *Psychoanalyse der Gesamtpersönlichkeit* (Psychoanalysis of the total personality), which represented the first step

toward a psychology of the psychoanalytic ego. Together with Hugo Staub he published a psychoanalytic study of criminology in 1929, *Der Verbrecher und seine Richter* (*The Criminal, the judge, and the Public: A Psychological Analysis*, 1956). In 1930 he was invited to the United States, where he occupied the first University Chair of psychoanalysis at the University of Chicago. In 1931 he worked at the Judge Baker Institute in Boston on juvenile delinquency and, in 1932, he founded the Chicago Psychoanalytic Institute, where he remained director until 1952. In 1933 he was admitted as a member of the Chicago Psychoanalytic Society and, in 1938, named professor of psychiatry at the University of Illinois. Alexander was one of the best known representatives of medicine seen from the point of view of psychoanalysis.

In 1939, in collaboration with Flanders Dunbar, Stanley Cobb, Carl Binger, and others, he founded the review *Psychosomatic Medicine*. "According to his theory on the specific psychodynamic conflicts associated with certain illnesses, a psychosomatic illness appears whenever there is an encounter between a certain personality type, predisposed to certain illnesses, and a specific conflict situation that lends itself to the formation of specific organic illnesses" (Bonin, 1983).

In 1955 he spent a year at the Center for Advanced Study in Behavioral Science in Palo Alto, California. Following this year, in 1956, he settled in Los Angeles, where he was named head of the Psychiatric Research Department at Mount Sinai Hospital. With support of the Ford Foundation, he organized a research project to study psychotherapeutic process by direct observation of patients and therapists. That same year Alexander became cofounder of the American Academy of Psychoanalysis. He died March 8, 1964, in Palm Springs, California.

Alexander believed that psychoanalysis was a branch of psychiatry, and was also convinced of the efficacy of a shortened course of therapy. Many of his critics considered the new ideas he introduced into analytic theory to be reductive.

ELKE MÜHLEITNER

*See also:* Allergy; Asthma; Criminology and psychoanalysis; Hungarian School; Psychosomatics; United States.

### **Bibliography**

Alexander, Franz Gabriel. (1927). *Psychoanalyse der Gesamtpersönlichkeit; neun Vorlesungen über die Anwendung von*

*Freud's Ich-Theorie auf die Neurosenlehre*. Leipzig, Vienna: Internationaler Psychoanalytischer Verlag.

———. (1961). *The scope of psychoanalysis. Selected papers of Franz Alexander*. New York: Basic Books.

Alexander Franz, and Staub, Hugo. (1956). *The criminal, the judge, and the public: A psychological analysis*, (rev. ed., Gregory Zilboorg, Trans.). Glencoe, IL: Free Press. (Original work published 1929)

Bonin, Werner F. (1983). *Die grossen Psychologen*. Düsseldorf, Germany: Econ Taschenbuch.

Grotjahn, Martin. (1966). Georg Groddeck, the untamed analyst. In Fr. Alexander, S. Eisenstein, M. Grotjahn (eds.), *Psychoanalytic pioneers* (p. 308–320). New York-London: Basic Books.

Hale, Nathan G. (1995). *The rise and crisis of psychoanalysis in the United States: Freud and the Americans, 1917–1985*. New York: Oxford University Press.

---

## **ALIENATION**

Inscribed in the opposition between the Same and the Other, alienation describes the condition of the subject who no longer recognizes himself, or rather can only recognize himself via the Other. The philosophical background of this concept derives from Hegel and then Marx. Classical psychiatry used the term to classify any mental illness in which the subject no longer knew who he was. Thanks to Jacques Lacan's study of Hegel's master/slave dialectic, the term no longer refers only to mental alienation, but retains the meaning it has in philosophy.

For Lacan, who followed Hegel on this point, human desire is constituted by mediation: "Man's desire finds its meaning in the other's desire, not so much because the other holds the keys to the desired object, but because his first objective is to be recognized by the other" (Lacan, p. 58). Specifically, the objective is to be recognized by the Other as a desiring subject, because the first desire is to have one's desire recognized. The conclusion is Lacan's well-known formula: "Man's desire is the desire of the Other," which doesn't mean that one desires another as object, but that one desires another desire, and wants to have one's own desire recognized by the Other. This is an echo of Hegel's master/slave dialectic (a struggle for pure prestige) where each consciousness wants to be recognized by the Other without recognizing it in turn ("each consciousness seeks the death of the other").

In this fight to the death, the one who accepts death in order to win becomes the Master; the other will become the slave. But the Master is taken in a trap, for he owes his status to the recognition of a slave-consciousness. The slave, however, will be liberated by the Master as his work extracts from things the consciousness of self that was lost in the struggle. The slave will end up, in the Marxist perspective, transforming the world in such a way that there is no place for the Master.

Thus the theme of alienation in Lacan refers to what is called a forced choice, or *vel*, which is the Latin word expressing an alternative where it is impossible to maintain two terms at once. The *vel* is alienating in that it gives a false choice, a forced choice (“your money or your life,” “me or you”). The Master’s freedom, which must pass through death to attain consciousness of self, is no freedom. Lacan derived several consequences from this structure of alternative, particularly in his critique of the Cartesian *cogito*, by indicating that thought and being cannot coincide. Thus, “I am where I do not think” and “it thinks there where I am not.”

Piera Aulagnier also took up the notion of alienation, but even though she borrowed from Lacan the relation of desire to the Other, her view more closely approached Freud’s thinking about collective hypnosis and its relation to the ego ideal. However, she worked in an entirely different context, refusing to make alienation one of the givens of human existence, but instead seeing it as one of the ways the psyche attempts to resolve conflict. First, she defined the notion of alienation by its goal, which is “to strive for a non-conflictual state, to abolish all causes of conflict between the identifying subject and the object of identification, between the I and its ideals” (Aulagnier, 1979). Thus she connects the notion to the aims of Thanatos, as a “desire for non-desire” and it can then be used in fields as diverse as collective psychology, passionate love, gambling, and drug addiction.

Nevertheless, Piera Aulagnier insists that alienation rests on an encounter between the desire for self-alienation, on the one hand, and the desire to alienate, on the other. The process of alienation seeks to erase the tension arising from this difference, whether it involves a subject that seeks to identify himself with the object identified, or a subject that wants to bring together the self image that comes back to him from others and the others themselves. Thus alienation appears to be a pathological modality, like neurosis or psychosis, that attempts to regulate the conflict between identifying

subject and the object identified. Whereas the neurotic differentiates between his self and its idealization and the psychotic posits the latter as realized in a delusion, the alienated subject idealizes an other who provides him with certainty. Unable to make these ideals a spur to progress, alienation produces a short circuit through the mediation of an idealized force. Alienation becomes even more effective when the alienated subject misapprehends “the accident occurring in his or her thought” (Aulagnier, 1979). It is as though this subject, once a prisoner, no longer has the objectivity needed to judge the situation.

In cases where a group feels alienated, not only is a group of subjects oppressed by a group of masters, but oppression infiltrates all relationships within the group. “Thus whatever the position one may occupy at the moment, every subject is both a victim and a potential murderer, given that one could always find oneself in the opposite position a moment later” (Aulagnier, 1979). If Jacques Lacan is indebted to Hegel, Piera Aulagnier leans on Aldous Huxley and George Orwell, both of whom revisit the historical experiences that have left their mark on the twentieth century, the Holocaust and the gulag.

But how does it happen that the subject chooses one outcome of alienation, rather than another? Piera Aulagnier would start from the metapsychological perspective on the conflict between the identifying subject and the object identified. This conflict is inscribed at the heart of a pathological relation to the ideal ego and to the ideal agencies in general. Alienation is characterized (as is psychosis, but in a different way) by an asymmetry between the I and its object, with no reciprocity between what the one recognizes and what the other recognizes. Thus a dominant pole is created (passionate investment in an object, the God-drug, Chance) by means of which the subject’s response will be alienated from the object that is seen as invulnerable; conversely the psychotic, who also recognizes the asymmetry in the relation, is going to try to flee from it and create outside of it a delusional object of identification that others refuse to recognize.

The notion of alienation as Piera Aulagnier conceives of it allowed for a reconsideration the nosographical categories. She particularly opened up a domain for renewed investigations on the question of addictions and on the perversions.

SOPHIE DE MIJOLLA-MELLOR

See also: Ego ideal; I; Ideology; Imaginary identification/symbolic identification; Mirror stage; Passion.

### **Bibliography**

- Aulagnier, Piera. (1979). *Les destins du plaisir: aliénation, amour, passion*. Paris: Presses Universitaires de France
- Lacan, Jacques. (2002). The function and field of speech and language in psychoanalysis. In *Écrits: a selection* (Bruce Fink, Trans.). New York: Norton. (Original work published 1953)
- Mijolla-Mellor, Sophie de. (1998). *Penser la psychose. Une lecture de l'œuvre de Piera Aulagnier*. Paris: Dunod.
- Palmier, Jean-Michel. (1969). *Lacan*. Paris: Éditions universitaires.

### **Further Reading**

- Bychowski, Gustav. (1967). The archaic object and alienation. *International Journal of Psychoanalysis*, 48, 384-393.
- Khan, Masud. (1979). *Alienation in perversions*. New York: International Universities Press.

---

## **ALLENDY-NEL-DUMOUCHEL, YVONNE (1890–1935)**

A French writer and art critic (under the pseudonym of Jacques Poisson), Yvonne Allendy-Nel-Dumouchel was born in Paris on September 3, 1890, and died there on August 23, 1935.

Alice Yvonne Nel-Dumouchel (she later gave up the name Alice) married René Allendy, homeopathic doctor and future founding member of the Paris Psychoanalytic Society, on November 19, 1912. In 1922, together with her husband, she created the Groupe d'études philosophiques et scientifiques pour l'examen des idées nouvelles, at the Sorbonne.

She was coauthor with him of *Capitalisme et Sexualité* (Capitalism and sexuality; 1931), a work whose subject matter touched upon communism and feminism. Claiming that life is an ongoing, and one-way, adaptation guided by our instincts, the authors affirm that capitalism intensifies the conflicts between the instincts of possession and those leading to procreation, that economic concerns increase in importance and are substituted, in the relations between the sexes, for values of a sentimental nature. "Woman experiences economic servitude combined with sexual dependence, her illusory emancipation is added to her responsibilities." Faced with these difficulties, they stipulate a kind of economic

regulatory system, national and international, culminating in the abolition of capitalism. As far as the modern family is concerned, they want to see the State substituted for the father as the economic provider. Their analysis cites both Freud and Engels.

Under the pseudonym of Jacques Poisson, Yvonne Allendy published a number of articles on the relationship between art and psychoanalysis. Speaking of the cinema, she affirmed that her subject must include the new field then of concern to researchers: the unconscious psychic apparatus, which dominates drama. Allendy claimed that only the cinema is capable of clearly reproducing the thought-image in all its dizzying rapidity.

In "Littérature moderne et psychanalyse" (April 1923), she makes use of Freud's methods to clarify literature, painting, and especially the work of the avant-garde. Apollinaire, Jean Cocteau, Philippe Soupault, and Blaise Cendrars were all examined for their Freudian symbolism. She suggested that there would be "more to gain in expanding our knowledge of human nature" if psychoanalysts were to study Dadaist texts "than there would be in having professors of literature explain classical texts."

She died in 1935 and her sister Colette became René Allendy's companion. Colette ran a gallery of modern art after the Second World War.

JEAN-PIERRE BOURGERON

See also: Allendy, René Félix Eugène; Cinema and psychoanalysis; Visual arts and psychoanalysis.

### **Bibliography**

- Allendy, René and Yvonne. (1931). *Capitalisme et sexualité*. Paris: Denoël & Steele.
- Poisson, Jacques. (1921, April). Vers une nouvelle unité plastique. *La Vie des lettres et des arts*, IV, 445–448.
- . (1923, April). Littérature moderne et psychanalyse. *La Vie des lettres et des arts*, XIV, 71–74.
- . (1925). Cinéma et psychanalyse. *Les cahiers du mois*, 16–17, 175–176.

---

## **ALLENDY, RENÉ FÉLIX EUGÈNE (1889–1942)**

A French homeopathic doctor and psychoanalyst, René Allendy was one of the founding members of the



Société psychanalytique de Paris. He was born on February 19, 1889, in Paris; his father was a shopkeeper from the Isle of Maurice and his mother was from Picardy. He died in Montpellier on July 12, 1942. When he was three, he contracted bronchial pneumonia from his nurse and during childhood lived through a number of often serious illnesses, including diphtheria complicated by quadriplegia. A student of the Marist brothers at the Collège Saint-Joseph in Paris, he completed his study of the humanities at the Lycée Janson-de-Sailly. He enrolled in the School of Oriental Languages to learn Russian. Later, he received a degree in Swedish from the Scandinavian Language Institute.

After receiving his medical degree from the School of Medicine of Paris on November 12, 1912 (his dissertation was entitled “L’Alchimie et la Médecine” [Alchemy and medicine]), he married Yvonne Nel-Dumouchel, just seven days later. Until her death in 1935, she remained his constant companion and collaborator. In 1936 he married Colette Nel-Dumouchel, Yvonne’s sister.

After being mobilized in 1914, he was gassed in Champagne, later declared tubercular, and given a disability pension. He practiced medicine in Paris at the Léopold-Bellan hospital and at the tuberculosis prevention clinics run by Hygiène Sociale de la Seine and the Saint-Jacques hospital, where he provided homeopathic treatments from 1932 to 1939. With his wife Yvonne he founded, in 1922, the *Groupe d’études philosophiques et scientifiques pour l’examen des idées nouvelles* (Philosophic and scientific study group for the examination of new ideas) at the Sorbonne, where a number of speakers from France and other countries spoke on science, art, and psychoanalysis. He defined the organization’s goals this way: “In order that the great movement of contemporary ideas might lead, without impediment, to practical realizations, it is essential to study the meaning of the future and hasten its spread.”

Analyzed in 1924 by René Laforgue, he practiced medicine, homeopathy, and psychoanalysis, studied esotericism and numerology, and published extensively in all these fields. Aside from his private practice, located at 67, rue de l’Assomption, in Paris, he worked as a psychoanalyst in the department of Professor Claude at Sainte-Anne.

In 1924 he wrote, together with Laforgue, *La Psychoanalyse et les Nevroses* (Psychoanalysis and

neuroses), which appeared with a preface by Professor Claude. The same year, the review *Le Disque vert* published “La Libido” in an issue dedicated to Freud. He wrote more than thirty articles for homeopathy journals and was equally productive in the field of psychoanalysis: *Les Rêves et leur Interprétation psychanalytique* (Dreams and their psychoanalytic interpretation; 1926), *Le Problème de la destinée* (The problem of destiny; 1927), *Orientations des idées médicales* (Orientations of medical ideas; 1928), *La Justice intérieure* (Interior justice; 1931) and *La Psychoanalyse, doctrine et application* (Psychoanalysis: theory and application; 1931). Although he often wrote about unorthodox subjects, his theoretical positions remained fairly orthodox; he was, however, open to many of Jung’s ideas, such as that of the collective unconscious. His book on Paracelsus remains a standard reference for admirers of the “accursed doctor.” With Yvonne he published *Capitalisme et Sexualité* (Capitalism and sexuality) in 1932.

He was a friend of Antonin Artaud, and he was also Artaud’s therapist; other patients included René Crevel and Anaïs Nin, who described Allendy in detail in her *Journal*. With Edouard Pichon, he drafted the first statutes of the Paris Psychoanalytic Society, where he was secretary from 1928 to 1931. In 1942, in Montpellier, he dictated his last thoughts on the illness that would soon take his life. A strange mixture of lucidity and blindness, these were published in 1944 as the *Journal d’un médecin malade* (Journal of a sick doctor).

JEAN-PIERRE BOURGERON

See also: Allendy-Nel-Dumouchel, Yvonne; France; Nin, Anaïs; Surrealism and psychoanalysis.

### Bibliography

- Allendy, René. (1931). *La justice intérieure*. Paris: Denoël & Steele.
- . (1932). *La psychoanalyse, doctrines et applications*. Paris: Denoël & Steele.
- . (1934). *Essai sur la guérison*. Paris: Denoël & Steele.
- . (1937). *Paracelse, le médecin maudit*. Paris: Gallimard.
- . (1944). *Journal d’un médecin malade*. Paris: Denoël.
- Allendy, René, and Allendy, Yvonne. (1931). *Capitalisme et sexualité*. Paris: Denoël & Steele.

Bouvard, Laurent. (1981). *La vie et l'œuvre du Dr René Allendy (1889–1942)*. Medical dissertation, Paris-Val-de-Marne, Créteil School of Medicine.

## ALLERGIC OBJECT RELATIONSHIP

The expression *allergic object relationship* appeared as the title of a talk given by Pierre Marty in 1957, published in the *Revue française de psychanalyse*. Influenced by the work of Maurice Bouvet, it extends the psychosomatic approach found in his work, which remains key for the question of allergies, and entails an asymptomatic model for psychosomatic functioning.

The relationship is characterized by a confusion between the personality of the patient and that of the analyst. A striking, if not total, identification sustains this confusion from the outset. This “communion” (in the sense almost of a transubstantiation) implies both identification and projection. The subject inhabits the object and is inhabited by it. The nature of the object—human, animal, plant, thing—matters little, for it is quickly invested as both host and guest. These patients give the impression and have the feeling of being sponges, possibly endowed with clairvoyance. (Zelig, the hero of Woody Allen’s film, is a striking example.) For Marty, the overlapping of identification and projection implies that such projection must be understood primarily as an extension of the limits of the ego as understood by Paul Federn.

This first step is followed by a lengthier and more nuanced attempt to modify the object, through which the subject tries to obliterate the limits between self and object, always by means of the same two mechanisms: cloaking the object in its own qualities through an act of “projection” and taking on the qualities of the object through identification. However, the qualities of the object must stay close to a certain ideal of the object. So one sees a capacity for object-choice, but the subject can only detach itself from an object by identifying with a new object, which leads to the loss of the previously invested object, but without any pain of loss or consequent work of mourning.

The very idea of a conflict between identifications is avoided in the allergic relation. The oedipal situation is thereby avoided and, when this is impossible, the risk of triggering a somatic crisis becomes manifest. Each of the objects individually can be an object of identification, but conflict (for example, oedipal) results in an interior rift that is avoided by the somatic allergic crisis.

This account, under the heading of “the allergic character,” would lead to a more comprehensive conception of psychosomatics, founded on the work of Pierre Marty, and enabling him to reveal its role in different forms of character splitting. Léon Kreisler (1980) continued this work in his notion of precocious appearance. The role played by the parents in the development of this relationship is more prominent in his conception than in Marty’s, for whom it is almost a given. Michel Fain compared the family dynamics typical of allergics with the constitutional defect discussed in the work of René Spitz: anxiety in the presence of the stranger.

ROBERT ASSÉO

*See also:* Allergy; Asthma.

### Bibliography

- Fain, Michael. (1969). Réflexions sur la structure allergique. *Revue française de psychanalyse*, 33 (2).
- Kreisler, Léon. (1981). *L'enfant du désordre psychosomatique*. Toulouse: Privat.
- Marty, Pierre. (1958). The allergic object relationship. *International Journal of Psycho-Analysis*, 39, 98–103.
- Szwec, Gérard. (1989). Figure de l'étranger, langage et régression formelle. *Revue française de psychanalyse*, 53, 6: 1977–1987.

## ALLERGY

Treatment of allergies became a part of psychosomatics, and subsequently psychoanalysis, following the work of the Chicago School, especially Franz Alexander and Thomas M. French in 1941. Alexander and French focused primarily on asthma rather than cutaneous allergic reactions, but later authors approached these initial studies quite differently. Distancing themselves from the idea of hysterical conversion, they established a link between psychic conflict and analogous somatic conflict. With respect to allergy, they looked for the conflicting elements they considered characteristic. For asthma, these conflicts were primarily conflicts between infants’ dependence on their mothers and instinctual demands that threatened this dependence. The crisis itself was associated with an inhibition of emotional expression, especially tears.

Because these factors were not specific, other authors returned to classical methods of analysis. Phyllis Greenacre (1945) insisted that oral sadism can be masked by streams of crocodile tears; here emotional expression assumes renewed importance in an interpretive framework. Jacob Arlow (1955) considered an allergic attack to be a manifestation of transference essentially associated with sadistic fantasies of incorporation. Melitta Sperling (1963) also demonstrated the links between allergies and pregenital factors. Philip C. Wilson (1968) hypothesized that transferential acting may be involved. In the end, the dimension of conversion returned to the foreground. Michel de M'Uzan (1968) insisted on the need to clarify the formation of somatic symptoms, and he turned to the notion of psychosomatic structure.

Pierre Marty reinvigorated the concept of allergies through his description of the allergic character (1976), which followed his account of the allergic object relation fifteen years earlier. He gave the allergic character the following traits: absence or avoidance of aggressiveness, a capacity for identification, absence or avoidance of conflict, considerable merging with the other, and projection as a mode of identification. To describe these traits in turn, absence or avoidance of aggressiveness gives subjects a socially agreeable cast, but is based on a weak capacity for negation, which in turn indicates a weak superego. The capacity for identification was already included in the allergic object relation. Merging with the other (absence of anxiety in the face of the foreign) is also characteristic of certain forms of primary epilepsy and allergic epilepsy, described by Marie-Thérèse Neyraut-Sutterman. Projection, described in 1957, becomes a mode of identification. As a consequence, subjects are unable to project bad objects or to distinguish good from bad.

Only when the allergic child is able, through stranger anxiety, to be afraid do allergic mechanisms begin to diminish. The features above can be found together in a character neurosis (which Pierre Marty referred to as a common allergy bundle), or they can appear as simple, relatively invasive traits that form a more or less split-off component of the personality, manifested only during regression (Pierre Marty referred to these as lateral lines) or deep splitting (parallel lines).

An allergic crisis can be triggered by the overriding of identificatory possibilities, as when the child is presented with two equally invested objects where the

identifications have been kept separate. For Pierre Marty, a somatic manifestation is seen as a way station within a regressive movement and not, as in the psychogenetic approach, as the somatic expression of a traumatic situation. For Michel Fain, the unconscious of the typical allergic is the seat of the mother's desire to have the child regress to a primary narcissistic stage of feelings of unity with her, a desire that keeps an entire portion of the ego of the allergic patient in an embryonic state.

For Marty, these properties and variations result in distinct therapeutic indications. In typical cases, the allergic individual is very adaptable, also in the allergic's relation to the analyst and to analysis. The downside of this is that there is a risk of an outbreak of somatic manifestations at the end of treatment. He therefore recommends psychotherapy as a prophylactic, which can help the patient to recognize unconscious factors and become aware of the danger of certain object relations. Marty believes that medical treatment is indicated for somatic disorders, and that analysis and psychotherapy should not be recommended for allergic manifestations.

This conception of an allergic quasi-structure has led to more recent work by Léon Kreisler (1982), Michel Fain (1969), and Gérard Szvec (1993), who have addressed these problems in children.

ROBERT ASSÉO

*See also:* Allergic object relationship; Asthma.

### Bibliography

- Alexander, Franz, and French, Thomas M. (1941). *Psychogenic factors in bronchial asthma*. Washington, DC: National Research Council.
- Arlow, Jacob. (1955). Notes on oral symbolism. *Psychoanalytic Quarterly*, 24, 63–74.
- Fain, Michel. (1969). Réflexions sur la structure allergique. *Revue française de psychanalyse*, 33 (2).
- Greenacre, Phyllis. (1945). Pathological weeping. *Psychoanalytic Quarterly*, 14 62–75.
- Kreisler, Léon. (1982). L'économie psychosomatique de l'enfant asthmatique: à propos d'un cas d'asthme grave chez un préadolescent *Psychothérapies*, 2 (1), 15–24.
- Marty, Pierre. (1976). *Les mouvements individuels de vie et de mort. Vol. 1: Essai d'économie psychosomatique*. Paris: Payot.

M'Uzan, Michel de. (1968). Comment on "Psychosomatic Asthma and Acting Out," by Ph. Wilson. *International Journal of Psycho-Analysis*, 49 (2–3), 333–335.

Sperling, Melitta. (1963). Fetishism in children. *Psychoanalytic Quarterly*, 32, 374–392.

Szwec, Gérard. (1993). *La psychosomatique de l'enfant asthmatique*. Paris: Presses Universitaires de France.

Wilson, C. Philip. (1968). Psychosomatic asthma and acting out: A case of bronchial asthma that developed de novo in the terminal phase. *International Journal of Psycho-Analysis*, 49 (2–3), 330–333.

---

## ALLGEMEINE ÄRZTLICHE GESELLSCHAFT FÜR PSYCHOTHERAPIE

The Allgemeine Ärztliche Gesellschaft für Psychotherapie (General Medical Society for Psychotherapy, AÄGP) was an organization of physicians headquartered in Germany dedicated to the promotion of psychotherapeutic theory and practice.

Its membership was comprised primarily of young internists and neurologists concerned with that aspect of a "crisis in medicine" having to do with a "materialist" university psychiatry beholden to abstract research and nosology (classification of diseases) instead of the prevention and treatment of mental disorders. Although there was some diversity of political and ideological opinion within the AÄGP, the membership by and large displayed a conservative medical critique of modern industrial society in general and the democratic Weimar Republic in particular. The AÄGP also sought to differentiate psychotherapy from neighboring disciplines inside and outside medicine; there was significant debate in particular about its relationship to psychiatry.

The AÄGP was founded as an international organization in 1928 with its own journal; its first annual congress had been held in Baden-Baden in 1926. In 1930 the journal was renamed *Zentralblatt für Psychotherapie* and was published in Leipzig until 1944. The society was reorganized in 1934 as a result of the Nazi seizure of power; a new Internationale Ärztliche Gesellschaft für Psychotherapie in Zurich under the presidency of Carl Gustav Jung was created along with the Deutsche Allgemeine Ärztliche Gesellschaft für Psychotherapie under Matthias Heinrich Göring. In 1940 Göring succeeded Jung; the AÄGP was resurrected as a West German entity in 1948 under psychiatrist and former president Ernst Kretschmer.

While some individual psychoanalysts were members of the AÄGP, the German Psychoanalytic Society did not recognize such an organization of "wild analysts." Although—and because—it was one of the purposes of the AÄGP to unify the schools of thought in psychotherapy, criticism within it of psychoanalysis, especially after 1928, was common. The Freudians who were members of the AÄGP tended to be revisionists like Karen Horney, Georg Groddeck, Wilhelm Reich, and Harald Schultz-Hencke, or apostates such as Carl Gustav Jung, Alfred Adler, and Wilhelm Stekel. In this regard, it was ironic that under National Socialism the society, for largely political reasons but still in keeping with Freud's view of the dangers of the medicalization of psychoanalysis, opened its membership to lay practitioners.

GEOFFREY COCKS

See also: Germany; Göring, Matthias Heinrich; Neopsychoanalysis; Schultz-Hencke, Harald Julius Alfred Carl-Ludwig.

### Bibliography

Cocks, Geoffrey. (1997). *Psychotherapy in the Third Reich: The Göring Institute* (2nd rev. ed.). New Brunswick, NJ: Transaction Publishers.

Lockett, Regine. (1985). *Erinnern und Durcharbeiten: zur Geschichte der Psychoanalyse und Psychotherapie im Nationalsozialismus*. Frankfurt am Main: S. Fischer.

---

**ALLOEROTICISM.** See *Autoeroticism*

---

**ALLOPLASTIC.** See *Autoplastic*

---

## ALMANACH DER PSYCHOANALYSE

The first *Almanach der Psychoanalyse* was published in 1926 by Internationaler Psychoanalytischer Verlag in Vienna. The job of publishing the *Almanach*, a highly effective publicity vehicle, was the first editorial decision made by Adolf Josef Storfer after the departure of Otto Rank as director of the press. Storfer's goal was to supply a kind of budget anthology of psychoanalysis

that would provide an overview of the psychoanalytic literature.

The *Almanach* was published once a year from 1926 until 1938, when the Germans entered Austria. There were thirteen volumes in all, comprising between two and three hundred pages each; nine thousand copies of each octavo volume were printed. Each number contained about twenty short articles written by psychoanalysts, scientists, and writers (including Thomas Mann, Stefan Zweig, and Hermann Hesse), articles that had previously appeared in the psychoanalytic literature, pages from books published by Internationaler Psychoanalytischer Verlag, and, in rare cases, unpublished writing. Freud helped support the *Almanach* by publishing “Humor” and “Fetishism,” two unpublished texts of his, in 1928. Each volume also contained portraits of the various psychoanalysts and critiques of works on psychoanalysis excerpted from newspapers and the trade press, as well as a list of new publications by Internationaler Psychoanalytischer Verlag.

ANDREA HUPPKE

See also: Internationaler Psychoanalytischer Verlag.

### **Bibliography**

Freud, Sigmund. (1927d). Humour. *SE*, 21: 159–166.

———. (1927e). Fetishism. *SE*, 21: 147–157.

---

**ALONE.** See *Capacity to be alone*

---

## **ALPHA-ELEMENTS**

Bion used the term “element” first in *Experiences in Groups* (1961), only in very general terms. In *A Theory of Thinking* (1962) Bion describes for the first time (except for an unpublished paper presented at a scientific meeting of the British Psycho-Analytical Society) the use of the concept of alpha-function as a working tool in the analysis of disturbances of thought: “It seemed convenient to suppose an alpha function to convert sense data into alpha-elements and thus provide the psyche with the material for dream thoughts and hence the capacity to wake up or go to sleep, to be conscious or unconscious. According

to this theory consciousness depends on alpha function and it is a logical necessity to suppose that such a function exists if we are to assume that the self is able to be conscious of itself in the sense of knowing itself from experience of itself.”

In this paper he describes how alpha function converts beta-elements (raw sense data) into *alpha-elements*, and he is particularly concerned with the differentiation that is established between the unconscious and the conscious. He considers *alpha-elements* to be elements necessary for consciousness. By “consciousness” he means specifically self-consciousness, since beta-elements in a sense are also conscious as raw perceptions. When the infant’s consciousness is invaded to an unbearable extent by beta-elements, the infant is driven to project these outside. When the beta-elements are transformed into alpha they become consciously apprehended, and a differentiation is established between the conscious and the unconscious. The *alpha-elements* can be consciously experienced, repressed, symbolized, and further worked on.

In *Learning from Experience* (1962), Bion gives the following example:

“If a man has an emotional experience when asleep or awake and is able to convert it into alpha-elements he can either remain unconscious of that emotional experience or become conscious of it. The sleeping man has an emotional experience, converts it into alpha-elements and so becomes capable of dream thoughts. Thus he is free to become conscious (that is wake up) and describe the emotional experience by a narrative usually known as a dream.”

Similarly, a person having a conversation converts the beta-elements into alpha, and thus freed of all the most primitive ways of functioning, he can have a rational conversation while not losing touch with his unconscious. *Alpha-elements* form what Bion calls a contact-barrier, the part of the mind in which beta-elements are transformed into alpha, and this contact-barrier could be seen as a flexible barrier of repression. “Alpha-elements comprise visual images, auditory patterns, olfactory patterns, and are suitable for employment in dream thoughts, unconscious walking, thinking, dreams, contact-barrier, memory.”

Bion developed his thought in a number of later writings, particularly in *Learning from Experience*. Alpha-elements are a product of alpha function. They

can be stored and repressed. They undergo further transformation and abstraction. They are the elements of dream thought, dream, myth, and conscious thought. And they form the contact-barrier between the conscious and the unconscious.

HANNA SEGAL

*See also:* Alpha function; Beta-elements; Bion, Wilfred Ruprecht; Contact-barrier; Grid; Infant development; *Learning from Experience*; Maternal reverie, capacity for; Primal, the; Protothoughts; Idea/representation; Symbolic equation; Transformations.

### **Bibliography**

Bion, Wilfred R. (1961). *Experiences in groups*. London: Tavistock Publications.

Bion, Wilfred R. (1962). *Learning from experience*. London: Heinemann.

---

## **ALPHA FUNCTION**

Wilfred Bion's work on the "alpha function" was based on Melanie Klein's concept of projective identification. He added a further dimension by suggesting that projective identification is not only an all-powerful fantasy in the infant's mind, but also its first means of communication.

Bion discussed the alpha function for the first time in an article titled "A Theory of Thinking" (1962), but the idea had already been prefigured in his work. For example, in "On Arrogance" (1958), he described a patient who perceived his analyst as someone who "could not tolerate it" (the "it" not being defined) (1958, p. 146). From this Bion drew the conclusion that the patient's means of communication was preverbal and occurred through projective identification with the primitive id, and that the patient was experiencing the analyst's insistence on verbalization as an attack on his means of communication.

In "Attacks on Linking" (1959), Bion described a patient who as a young child could not contain his fear of death. He dissociated himself from it and at the same time from a part of his personality, and projected it onto his mother: "An understanding mother is able to experience the feeling of dread, that this baby was striving to deal with by projective identification, and yet retain a balanced outlook"

(p. 313). By projecting its terror onto the mother, the infant makes it into *her* experience and communicates to her its own distress. This situation is repeated in analysis. In this study, Bion stressed that projective identification has a realistic aspect that can elicit an appropriate response from the mother. If this response is not forthcoming, the baby's fear of death is reinforced and cannot be processed.

In "A Theory of Thinking," Bion formed the hypothesis of an alpha function exercised by the mother when she processes the baby's projective identification and converts what he calls "nascent sensory data," including emotional data, or beta elements, into alpha elements—the materials of dream thoughts and conscious thoughts:

It seemed convenient to suppose an alpha-function to convert sense data into alpha-elements and thus provide the psyche with the material for dream thoughts, and hence the capacity to wake up or go to sleep, to be conscious or unconscious. According to this theory, consciousness depends on alpha function, and it is a logical necessity to suppose that such a function exists if we are to assume that the self is able to be conscious of itself in the sense of knowing itself from experience of itself (p. 308).

Bion deliberately refrained from giving a definition of the alpha function, since he could only deduce its elements. He let it be understood that further study of it was needed. Instead of giving definitions, he described the process and provided the following model:

the infant, filled with painful lumps of faeces, guilt, fears of impending death, chunks of greed, meanness and urine, evacuates these bad objects into the breast that is not there. As it does so the good object turns the no-breast (mouth) into a breast, the faeces and urine into milk, the fears of impending death and anxiety into vitality and confidence, the greed and meanness into feelings of love and generosity and the infant sucks its bad property, now translated into goodness, back again. As an abstraction to match this model I propose an apparatus, for dealing with these primitive categories of I, that consists of a container and the contained. The mechanism is implicit in the theory of projective identification in which Melanie Klein formulated her discoveries of infant mentality. (1963, p. 31).

The concept of the alpha function led to that of the container/contained relationship. The internalization

of the latter provides the elementary thought-thinking apparatus. The mother's receptivity to the child's projective identification is a central factor in this process. Her receptivity is dependent upon what Bion called the maternal capacity for reverie—a dreamlike state whose contents are love for the child and its father.

Deficiencies in maternal reverie or excessive feelings of omnipotence or envy on the part of the infant can interfere with the alpha function and the container/contained relationship. The alpha function is related to—conjoined with—the shift from the paranoid-schizoid position to the depressive position.

HANNA SEGAL

*See also:* Alpha-elements; Arrogance; Beta-elements; Beta screen; Bion, Wilfred Ruprecht; Contact-barrier; Hallucination; Infantile psychosis; Lack of differentiation; *Learning from Experience*; Nonverbal communication; Object; Primary object; Protothoughts; Psychotic panic; Realization; Transformations.

### **Bibliography**

- Bion, Wilfred R. (1967). On arrogance. In his *Second thoughts*. London: Heinemann. (Original work published 1953)
- . (1959). Attacks on linking. *International Journal of Psycho-Analysis*, 40 (5–6) 308.
- . (1967). A theory of thinking. In *Second thoughts*. London: Heinemann. (Reprinted from *International Journal of Psycho-Analysis*, 43,(1962) 4–5.)
- . *Elements of psycho-analysis*. London: Heinemann, 1963.

## **ALTER EGO**

The representation of an other complicit in the subject's narcissism, or self-object, the alter ego refers to the narcissistic need of an other similar to the self, a factor in the development of the self. The term appeared in the work of Heinz Kohut in 1971 in the context of alter ego transference, a form of mirror transference. After 1984, given the autonomy of the alter ego transference, it appears as a constituent of the self, along with the grandiose self, the pole of ambitions, and the idealized parental imago, the pole of ideals. Defined as an arc of tension between the two poles, the alter ego takes into account the harmony of

the self, while the mirror affirms the vigor of the self and its idealization and cohesion. The line of development of the alter ego is important throughout the period that extends from the age of four to ten years; friendship, the need for someone like us, sometimes changes into the need for an imaginary companion. The alter ego is associated with humanity and sexual identity through self-identification—the father's true son. The reverse would be a Kafkaesque world of dehumanizing experiences. When this sector is stopped, repressed needs remain fixed and are difficult to verbalize because of the shame they arouse. The alter ego is associated with other needs and narcissistic transferences. Within this context, the concept of identification loses the specificity it has in Freudian metapsychology in terms of the constitution of the ego.

AGNÈS OPPENHEIMER

*See also:* Bipolar self; Compensatory structures; Mirror transference; Narcissistic transference; Self; Twinship transference/alter ego transference.

### **Bibliography**

- Kohut, Heinz. (1971). *The analysis of the self*. New York: International Universities Press.
- . (1977). *The restoration of the self*. New York: International Universities Press.
- . (1984). *How does analysis cure?* Chicago: University of Chicago Press.

---

**ALTERITY.** *See* Otherness

---

## **ALTHUSSER, LOUIS (1918–1990)**

Louis Althusser, a French philosopher, was born in Birmandreïs, Algeria, on October 16, 1918, and died in Le Mesnil-Saint-Denis, Yvelines, France, on October 22, 1990. Born into a family of practicing Catholics, Althusser's secondary schooling took place at the Lycée Saint-Charles in Marseille. He prepared for the entrance competition to the École Normale Supérieure (ENS) at the Lycée du Parc in Lyon, where he was a student of Jean Guilton, then of Jean Lacroix. He was accepted for admission in 1939 but was mobilized in September and became a prisoner of war. He

didn't begin his studies at the ENS until October 1945. It was in the prison camp that he learned about communism. Meetings at the ENS, primarily with Jean-Toussaint Desanti and Tran Duc Thao, gave him a better understanding of Marxist thought. Althusser taught philosophy at the ENS until 1980. There he met Jacques Lacan during the years when Lacan brought his seminar to the school.

Althusser is known as a chief theoretician of ideology. In *Reading "Capital"* (1979) he introduced a new reading of Marx, a "symptomal" reading, which, through a constructed discourse, is able to redefine the operating concepts and formal structure of his thought. This work led him to postulate a break between the works of the young Marx, where theoretical humanism is still present, and the mature works, which display a "theoretical antihumanism."

He criticized the spontaneous ideology that infiltrated so-called scientific discourse and set forth the foundations of a critical epistemology. One of his most important texts is "Ideology and Ideological State Apparatuses" (2001). In it he demonstrates the doubling of the subject and the specular structure of every ideology. Althusser returned to Ludwig Feuerbach's theory of the specular relation, Hegel's theory of recognition, and a theory of guarantees whose origins can be traced back to Spinoza, but gave them a new interpretation. He also made use of psychoanalytic ideas: the question of identification and the Lacanian themes of the split (or barred) subject and alienation from the Big Other in the specular relation. Althusser used this theoretical approach to address psychoanalysis. In his work he also attempted to articulate psychic and social processes outside the conventional patterns of Freudian and Marxist thought.

In addition, Althusser had direct experience of psychotherapy with a psychoanalyst. Althusser suffered from serious psychiatric problems, which required his hospitalization on several occasions. In 1980, in a moment of dementia, he killed his wife, H el ene. In *The Future Lasts Forever* (1993), most of which was written in 1985, Althusser acknowledges his painful efforts at understanding carried out after this tragic event.

Althusser trained an entire generation of scholars to be rigorous and critical in their reading of philosophy. Throughout the 1970s his influence was considerable and international in scope.

MICH ELE BERTRAND

*See also:* France; Ideology; Marxism and psychoanalysis; Structuralism and psychoanalysis.

### Bibliography

Althusser, Louis. (1966). Freud and Lacan. In his *Writings on psychoanalysis: Freud and Lacan* (Jeffrey Mehlman, Trans.). New York: Columbia University Press. (Original work published 1964)

———. (1993). *The future lasts forever: A memoir* (Richard Veasey, trans.). New York: New Press.

———. (2001). Ideology and ideological state apparatuses. In his *Lenin and philosophy and other essays*. New York: Monthly Review Press. (Original work published 1970)

———, and Balibar,  tienne. (1979). *Reading "Capital"* (Ben Brewster, Trans.). New York: Schocken Books. (Original work published 1965)

---

## ALTRUISM

Freud refers to the concept of altruism approximately ten times in his work, most often in a social or cultural context. In "Thoughts for the Times on War and Death" he writes:

Throughout an individual's life there is a constant replacement of external by internal compulsion. The influences of civilization cause an ever-increasing transformation of egoistic trends into altruistic and social ones by an admixture of erotic elements. In the last resort it may be assumed that every internal compulsion which makes itself felt in the development of human beings was originally—that is, in the *history of mankind*—only an external one. Those who are born to-day bring with them as an inherited organization some degree of tendency (disposition) towards the transformation of egoistic into social instincts, and this disposition is easily stimulated into bringing about that result. (1915b, p. 282).

In other cases, Freud uses the term most frequently against a background of what he called, in an exchange with Oskar Pfister, his "joyous pessimism." After pointing out that except when in love, "the opposite of egotism, *altruism*, does not, as a concept, coincide with libidinal object-cathexis" (1916–17a [1915–17], p. 418), he added, rather laconically, in *Civilization and Its Discontents*, "the development of the individual seems to us to be a product of the interaction between



two urges, the urge towards happiness, which we usually call 'egoistic', and the urge towards union with others in the community, which we call 'altruistic'. Neither of these descriptions goes much below the surface. In the process of individual development, as we have said, the main accent falls mostly on the egoistic urge (or the urge towards happiness); while the other urge, which may be described as a 'cultural' one, is usually content with the role of imposing restrictions" (1930a [1929], p. 140).

However, in the third part of *The Ego and the Mechanism of Defence* (1936/1937), Anna Freud provides an example of two types of defense, namely, "identification with the aggressor" and "a form of altruism." And in connection with the mechanism of projection, she conceives of "altruistic surrender" (*altruistische Abtretung*, according to the expression used by Edward Bibring):

The mechanism of projection disturbs our human relations when we project our own jealousy and attribute to other people our own aggressive acts. But it may work in another way as well, enabling us to form valuable positive attachments and so to consolidate our relations with one another. This normal and less conspicuous form of projection might be described as 'altruistic surrender' of our own instinctual impulses in favour of other people (p. 133).

Using a clinical example, Anna Freud analyzes the transference of the subject's own desires to others, a transference that enables the subject to participate in the instinctual satisfaction of another person through projection and identification. In speaking of this process, she refers to Paul Federn's comments concerning identification through sympathy.

The section of the book devoted to the study of two mechanisms of defense is placed between a chapter on the preliminary stages of defense—the avoidance of unpleasure in the face of real dangers (negation through fantasy, negation through acts and words and withdrawal of the ego)—and a chapter on the phenomena of puberty and the defenses arising from fear associated with the intensity of instinctual processes. To Anna Freud, the mechanisms of identification with the aggressor and altruism can be conceived as intermediary stages of defense, centered on the transition from anxieties arising from external dangers to subsequent anxieties arising from internal dangers.

This explains the projection inherent in both types of defense and the role of the superego in the genesis of altruistic surrender: "Analysis of such situations shows that this defensive process has its origin in the infantile conflict with parental authority about some form of instinctual gratification" (p. 141). Other passages in her work support this view: "Her early renunciation of instinct had resulted in the formation of an exceptionally strong super-ego, which made it impossible for her to gratify her own wishes... She projected her prohibited instinctual impulses on to other people, just as the patients did whose cases I quoted in the last chapter... In most cases the substitute has once been the object of envy" (pp. 135-36, 136, 141). She also points out that altruistic surrender is a means for overcoming narcissistic humiliation.

Finally, for Anna Freud, altruism could involve libidinal impulses as well as destructive impulses and, moreover, could affect either the realization of desires or their renunciation. Her analysis of the mechanism of defense finishes with an approach to its connection with the fear of death, by examining the bonds between the hero Cyrano de Bergerac and his friend Christian. Anna Freud provides a concluding note on the similarity between the conditions needed to initiate altruistic surrender and those present during the formation of masculine homosexuality.

Anna Freud's position was subsequently revisited with respect to such concerns as the psychodynamics of anorexic adolescents.

BERNARD GOLSE

See also: Antinarcissism; Burlingham-Tiffany, Dorothy; Identification with the aggressor; Reaction-formation.

### **Bibliography**

- Freud, Anna. (1937). *The ego and the mechanisms of defence*. London: Hogarth. (Original work published 1936)
- Freud, Sigmund. (1915b). Thoughts for the times on war and death. *SE*, 14: 275-300.
- . (1916-17a [1915-17]). Introductory lectures on psycho-analysis. *SE*, 15-16.
- . (1930a [1929]). Civilization and its discontents. *SE*, 21: 64-145.

### Bibliography

- Freud, Anna. (1936). A form of altruism. In *Writings of Anna Freud* (Vol. 2, pp. 122-134).
- McWilliams, Nancy. (1984). The psychology of the altruist. *Psychoanalytic Psychology*, 1, 193–214.
- Seelig, Bud, et. al. (2001). Normal and pathological altruism. *Journal of the American Psychoanalytic Association*, 49, 933–960.

### ALVAREZ DE TOLEDO, LUISA AGUSTA REBECA GAMBIER DE (1915–1990)

An Argentine doctor and psychoanalyst, Luisa Agusta Rebeca Gambier de Alvarez de Toledo was born June 13, 1915, in the 9 de Julio section of Buenos Aires, where she died on September 5, 1990. “Rebe,” as she was known to her friends, expressed an interest in medicine in childhood, which led to her later studies in the capital. She discovered psychoanalysis when still a student, and became a member of the earliest psychoanalytic groups in the country, even before the creation of the Asociación Psicoanalítica Argentina (APA). Her meeting with Matilde and Arnaldo Rascovsky, through whom she became familiar with the field, led to her decision to pursue psychoanalysis as a career. Although she was not a founding member of the APA, she took an active part in the activities of the creators of the Argentine psychoanalytic movement.

She began her training analysis with Celes Cárcamo and was officially supervised by Angel Garma and Enrique Pichon-Rivière. She became a member of the APA in 1945 with the presentation of her study “A Case of Examination Neurosis,” and a fellow in 1950 with the presentation of her “A Contribution to the Understanding of the Symbolic Meaning of the Circle” and “On the Mechanism of Sleep and Dreaming.”

In 1946 she contributed to the creation of the first department of psychoanalytic psychiatry for adolescents at the hospital then known as the Hospicio de las Mercedes, under the direction of Enrique Pichon-Rivière and Arminda Aberastury. Between 1955 and 1958 she made regular trips to Montevideo, where she gave seminars and supervised other psychoanalysts, and in so doing contributed to the formation of the Uruguayan Psychoanalytic Association and helped train its members.

In 1954 she became a training analyst and, on this occasion presented her “Análisis del asociar, del interpretar y de las palabras” (The analysis of associating, interpreting, and words). This study, which became a classic of psychoanalytic literature, was published in the *Revista de psicoanálisis* in 1954 and had long-lasting influence on the evolution of the field. The author saw language as integral to psychoanalysis and showed how “the fact of speaking, as an act and independently of the content of the words, satisfies oral, anal, phallic, and genital libidinal impulses,” and that “by analyzing ‘the fact of associating’ and ‘the fact of interpreting’ in itself, there arises the primitive identity of the act, the image, and the object, which is realized in the act of speaking and listening to the analyst.”

Later she grew interested in the development of psychoanalytic research involving the use of hallucinogenic drugs. It was during this period that she wrote “Ayahuasca” (1960), which addressed the use of LSD in certain communities of Upper Peru. She was forced to interrupt her research when, for reasons beyond her control, the consumption of LSD was made illegal by the then current government.

Within the APA she assumed a number of important roles: secretary of the executive committee (1952–1953), treasurer (1953–1954), and president (1956–1957). She continued to assume positions of responsibility within the organization until 1972. Later in life, she turned her efforts toward providing an analytic space for several of her institutional colleagues.

AUGUSTO M. PICOLLO

*See also:* Argentina; Language and disturbances of language.

### Bibliography

- Alvarez de Toledo, Luisa. (1954). El análisis del “asociar”, del “interpretar” y de “las palabras”. *Revista de psicoanálisis de la Asociación psicoanalítica argentina*, XI (3), 267–313.
- . (1960). Ayahuasca. *Revista de psicoanálisis de la Asociación psicoanalítica argentina*, XVII (1), 1–9.
- . (1996). The analysis of “associating,” “interpreting” and “words,” con comentarios de Janine Puget y María Isabel Siquier. *International Journal of Psycho-Analysis*, LXXVII, 291–322.
- Baranger, Madeleine, Baranger, Willy, and Mom, Jorge M. (1990). Obituario: Luisa Gambier de Alvarez de Toledo.

*Revista de psicoanálisis de la Asociación psicoanalítica argentina, XLVII (3), 410–413.*

Mom, Jorge M., Foks, Gilda, and Suárez, Juan Carlos. (1982). *Asociación psicoanalítica argentina 1942–1982*. Buenos Aires: APA

## AMAE, CONCEPT OF

The concept of *amae* is a concept which derives from a unique Japanese word *amae*, a noun form of *amaeru*, an intransitive verb. It primarily refers to what an infant feels toward the mother when it recognizes and seeks her, hence it is nonverbal to begin with, but it acquires its first-person dimension when a child comes to learn the meaning of *amae*. *Amae* may be applied to an adult in a similar situation involving someone who is supposed to take care of him or her. It is on the basis of these linguistic facts plus the clinical experience that Takeo Doi arrived at the concept of *amae* indicating whatever happens consciously or unconsciously in a person vis-à-vis a possible caretaker.

*Amae* corresponds to what Freud (1912d) calls “the affectionate current,” which should combine with “the sensual current” in love. Also, it should correspond to the process of identification, since Freud (1921c) states that “identification is known to psychoanalysis as the earliest expression of an emotional tie with another person.” What is closest in meaning to *amae* is “primary love or passive object love” defined by Michael Balint (1935/1965). Interestingly, he specifically states that “all European languages...are all so poor that they cannot distinguish between the two kinds of object love, active and passive.” Among the empirical studies of infants, the attachment behavior which John Bowlby focused upon overlap with the behavior of *amae*. It is significant that *amae* is the exact reverse of envy which Melanie Klein emphasized in her thinking of mental life. The self-object needs defined by Heinz Kohut also correspond to *amae*.

*Amae* thus bridges many important concepts in psychoanalysis. Its strength lies in the fact that being a verb-noun it represents something alive, and thus suggests a potential feeling. According to Freud’s earlier formulation of instincts, *amae* can be a representative of the ego instincts.

TAKEO DOI

See also: Japan; Tenderness.

## Bibliography

Balint, Michael. (1965). *Critical notes on the theory of the pregenital organizations of the libido. Primary love and psycho-analytic technique*. New York: Liveright. (Original work published 1935)

Bowlby, John. (1969). *Attachment and loss*. London: The Hogarth Press.

Doi, Takeo. (1980). The concept of *amae* and its psychoanalytic implications. *International Review of Psychoanalysis*, 16, 349–354.

———. (1991). A propos du concept d’*amae*. *Psychiatrie de l’enfant*, 34, 277–284.

Freud, Sigmund. (1912d). On the universal tendency to debasement in the sphere of love. *SE*, 11: 177–190.

———. (1921c). Group psychology and the analysis of the ego. *SE*, 18: 65–143.

## AMBIVALENCE

Ambivalence is the simultaneous presence of conflicting feelings and tendencies with respect to an object. During the winter meeting of Swiss psychiatrists in Berne on November 26–27, 1910, Paul Eugen Bleuler described, with respect to schizophrenia, the simultaneous existence of contradictory feelings toward an object or person and, with respect to actions, the insoluble concurrence of two tendencies, such as eating and not eating. In “The Rat Man” (1909d) Freud had already indicated that the opposition between love and hate for the object could explain the particular features of obsessive thought (doubt, compulsion). In *Totem and Taboo* (1912–13a) he adopted the term “ambivalence” proposed by Bleuler in the text of his conference published in 1911 in the *Zentralblatt*.

For Freud the term, in its most general sense, designated the presence in a subject of a pair of opposed impulses of the same intensity; most frequently this involved the opposition between love and hate, which was often expressed in obsessional neuroses and melancholy. In 1915, in his metapsychological writings, he added that it was the loss of the love object that, through regression, caused the conflict of ambivalence to appear. In 1920 Karl Abraham emphasized the intensity of the sadistic fantasy associated with urinary and digestive functions. In 1924 he extended and transformed the Freudian schema of the evolution of

the libido into a complete picture of the development of the relation to the object along two lines: the partial or total nature of the investment in the object, and ambivalence. The precocious oral stage of sucking is preambivalent, neither love nor hate are felt toward the object. There follow four ambivalent phases: the late oral stage, which is cannibalistic and seeks the total incorporation of the object, the precocious anal-sadistic stage, which seeks the expulsion and destruction of the object, the late anal-sadistic stage, which seeks its conservation and domination, and finally the precocious-phallic genital stage. The final genital phase of love towards a complete object is postambivalent.

Freud integrated Abraham's contributions in the thirty-second of his *New Introductory Lectures on Psycho-analysis* (1933a). Within the oedipal conflict ambivalence is resolved as a neurotic symptom, either through a reaction formation or through displacement (1926d). Reformulated in the second theory of instincts, ambivalence becomes part of the fundamental instinctual dualism: life instinct/death instinct.

For Melanie Klein ambivalence was key in formulating a theory of depression. The interplay of introjection and projection, the dialectic of good and bad objects, and depressive anxiety, signaling the fear of destroying the maternal object, are the apparent manifestations of the conflict of ambivalence. Together they constitute the ego and work toward resolving the oedipal conflict.

For Paul-Claude Racamier (1976), while melancholy is hyperambivalent in that it results from an intense struggle between love and hate, schizophrenia must be considered as a fundamentally antiambivalent process, where "contrary impulses ... radically split, fuse separately in a nearly pure state, presenting themselves alternately to the same object or simultaneously to partial objects that are always distinct and divided."

VICTOR SOUFFIR

*See also:* Bleuler, Paul Eugen; Contradiction; Essential depression; Doubt; Fusion/defusion; "Instincts and their Vicissitudes;" Melancholia; "Mourning and Melancholy;" Parricide Phobias in children; Phobia of committing impulsive acts; Object; Obsessional neurosis; Orality; Oral-sadistic stage; Reaction formation; Schizophrenia; Taboo; Totem/totemism.

## Bibliography

Abraham, Karl. (1927). A short history of the development of the libido. In *Selected papers of Karl Abraham* (Douglas Bryan and Alix Strachey, Trans.). London: Hogarth Press. (Original work published 1924)

Bleuler, Eugen. (1952), *Dementia praecox* (Joseph Zinkin, Trans.). New York: International Universities Press. (Original work published 1911)

Freud, Sigmund. (1909d). Notes upon a case of obsessional neurosis. *SE*, 10: 151–318.

———. (1912–13a). Totem and taboo. *SE*, 13: 1–161.

———. (1926d [1925]). Inhibitions, symptoms, and anxiety. *SE*, 20: 75–172.

———. (1933a [1932]). New introductory lectures on psycho-analysis. *SE*, 22: 1–182.

Klein, Melanie. (1975). A contribution to the psychogenesis of manic-depressive states. In *The writings of Melanie Klein*. London: Hogarth Press, 1975. (Reprinted from *International Journal of Psycho-Analysis*, 16 (1975), 145–174.)

———. (1975). The Oedipus complex in the light of early anxieties. In *The writings of Melanie Klein*. London: Hogarth Press, 1975. (Reprinted from *International Journal of Psycho-Analysis*, 26 (1945), 11–33.)

Racamier, Paul-Claude. (1976). L'interprétation psychanalytique des schizophrénies. In *Encyclopédie médico-chirurgicale*. Paris: EMC.

## Further Reading

Benedek, Therese. (1977). Ambivalence, passion and love. *Journal of the American Psychoanalytic Association*, 25, 53–80.

Eissler, Kurt R. (1971). Death drive, ambivalence, and narcissism. *Psychoanalytic Study of the Child*, 26, 25–78.

Parens, Henri. (1979). Ambivalence: drives, symbiosis—separation-individuation process. *Psychoanalytic Study of the Child*, 34, 385–420.

Schwartz, Charlotte (1989). Ambivalence: relation to narcissism and superego development. *Psychoanalytic Review*, 76, 511–527.

## AMENTIA

Amentia, or confusion, is a state of acute hallucinatory delirium; it was described with this name by Theodor Meynert in *Leçons cliniques de psychiatrie* (1890). Meynert, who had been a professor of psychiatry since 1873 at the University of Vienna, believed in an anatomic-clinical theory of psychiatry and did not

attribute any meaning to the hallucinations that arose during amentia, considering them merely a disorderly flow of “accessory representations” from “cortical exhaustion” and excessive irrigation of subcortical centers, which were considered to be the seat of sensory impressions.

Freud, faithful to his teacher of 1883, also referred to the clinical value of the concept of amentia, in spite of the differences between them (Jones, 1953). He wrote of “a fine daydream” (Freud, 1916–17f) and, as demonstration of this, a “hallucinatory psychosis of desire.”

Although Freud mentioned the concept much earlier (1894a), it is not until his *A Metapsychological Supplement to the Theory of Dreams* (1916–17f) that he would see in amentia an element of comparison, with which to explain the role of belief in the hallucinatory fulfillment of desire in dreams. The regression of the preconscious to mnemonic images of things invested by the unconscious would be unable to explain such belief if, in both cases, the conflict with reality (associated with the functions of consciousness) weren't eliminated. Amentia is unlike the dream state, where it is through the wish to sleep that the subject loses interest in reality. Rather, in the hallucinatory psychosis of desire, the subject denies a reality that is unbearable because of the loss it inflicts, and is thus open to the free play of hallucinatory fantasies.

AUGUSTIN JEANNEAU

*See also:* Delusion; *Metapsychological Supplement to the Theory of Dreams, A*; Meynert, Theodor.

### **Bibliography**

- Freud, Sigmund. (1894a). The neuro-psychoses of defence. *SE*, 3: 45–61.
- . (1916–17f). A metapsychological supplement to the theory of dreams. *SE*, 14: 222–235.
- Jones, Ernest. (1953–1957). *Sigmund Freud: Life and work*. London: Hogarth Press.
- Meynert, Theodor. (1890). L'amentia ou confusion. In C. Levy-Friesacher (Ed.), *Meynert-Freud “L'amentia.”* Paris: Presses Universitaires de France, 1983.

## **AMERICAN ACADEMY OF PSYCHOANALYSIS**

The two major psychoanalytic organizations in the United States, the American Academy of Psychoanalysis

(Academy) and the American Psychoanalytic Association (American), now share similar theoretical orientations and are working closely together in the Psychoanalytic Consortium. However, this has not always been the case.

The Academy was formed as a reaction against perceived thought control efforts by certain officers of the New York Psychoanalytic Institute, a member of the American, which demanded conformity to a sharply restricted view of the intrapsychic libido theory. The Academy's orientation was that, in addition to intrapsychic dynamics, biological facts, interpersonal relations, the family, and the broader culture were all significant in personality development and pathology. Thus instead of a unitary theory, the Academy accepted that multiple interacting factors were significant. From its very beginning, the Academy established a democratic and scientific organization, where divergence, dialogue, and creative growth in psychoanalysis were strongly encouraged.

The split in American psychoanalysis started in 1941, at a business meeting of the New York Psychoanalytic Society, when Karen Horney was disqualified as a training analyst because she was disturbing the candidates with her ideas about culture. A number of analytic institutes split off from the American, and in 1955 Clara Thompson called a meeting of eminent psychoanalysts. Amongst those present were Franz Alexander, Abram Kardiner, Jules Masserman, and Sándor Radó, who all encouraged the formation of another national psychoanalytic organization where there would be freedom to exchange ideas in psychoanalysis and with other scientific disciplines. Franz Alexander (Alexander and Selesnick, 1966), a former president of the American, stated that the premature standardization and rigidity of teaching in the American was too past-oriented and not sufficiently creative and future-oriented. Psychoanalysis was still a developing field and the exchange of clinical experience as well as input from science and the humanities was crucial. Conformity would only stifle the growth and development of psychoanalysis as a science. Tolerance for uncertainty and ambiguity are a necessary condition for creativity.

The Academy was established in 1956. Under its constitution, the Academy admits individual members and not institutes, so as not to interfere with the freedom of each institute's jointly determined theoretical approach and politics. The first president of the

Academy was a woman, Janet Rioch Bard, and many other eminent medical psychoanalysts, both men and women, have been elected president since then.

It is interesting that the Academy was similar to the Kleinian group in England, since both can trace their origins to Sándor Ferenczi, who maintained the importance of interpersonal relations and the culture. Ferenczi focused more on maternal nurturance during infancy and relationships in childhood. He also stressed the importance of empathic connection in treatment, especially with more difficult patients, so as to undo trauma or deprivation and provide a corrective emotional experience. He also explored the transference/counter-transference relationship between therapist and patient. Both Thompson and Klein were analyzed by Ferenczi, who strongly influenced their approach. Horney (1922) had rejected Freud's explanation of feminine psychology as due to penis envy and the castration complex, and she stressed that femininity was inborn, being shaped by interpersonal relations and the culture.

The members of the Academy have made important contributions not only to individual psychoanalytic treatment and theory, especially with more troubled patients, but also in psychosomatics, and family and group therapy. Current research in ethology and direct infant observation have validated the importance of an attuned attachment to the mother during the pre-oedipal period, and anthropological research has found that the oedipal conflict is not universal but culturally variant.

In later years, the American reversed its rigid adherence to a unitary theory and embraced the inclusive and democratic ideals that were the very foundation of the Academy. Now both the Academy and the American consider divergent theoretical orientations and include findings from anthropology, culture, and group and family therapy.

Freud was an accomplished researcher in the neurosciences and published his laboratory findings. He was aware that memory was stored in the brain cells and transmitted through synapses. Freud did attempt to develop a neurophysiological method in his "Project for a Scientific Psychology" (1950c [1895]), but not having the technology to integrate the mind and the brain, he focused on the mind. Part of the problem in psychoanalysis was that it did not have a hard and firm scientific foundation. In the resulting search for certainty, a unitary theory was embraced by classical analysts to give the illusion of scientific validity. This

contributed to the split in the psychoanalytic movement in the United States, and the division in England. However, Freud himself was aware that his metapsychology was weak, and that psychoanalysis was not the hard science that he had hoped it to become.

Increasingly the technology exists that can allow one to integrate understandings of the mind and the brain, especially with imaging techniques. The new findings of neurobiology will serve to provide a scientific foundation to psychoanalysis, and further help to bring the psychoanalytic movement together. Thus, Freud's hope that psychoanalysis could become a hard science is still alive; work that reduces the mind/body split could yet ensure that theory and therapy become grounded on a firm scientific basis.

Both the American Psychoanalytic Association and the American Academy of Psychoanalysis have now continued with similar theoretical orientations concerning biological, intrapsychic, interpersonal, and cultural factors in personality development and pathology. However, they have diverged in their methods of sustaining membership. The American has included psychologists and social workers besides psychiatrists, but has remained wholly psychoanalytic. The Academy has included psychiatrists with some analytic training or who are analytically oriented, but remained medical. Accordingly, the Academy changed its name to reflect this change to the American Academy of Psychoanalysis and Dynamic Psychiatry. During the presidency of Samuel Slipp, the Academy was established as an official Affiliate of the American Psychiatric Association. Now, only the Academy holds its annual meeting in the same location as the American Psychiatric Association. Both the American and the Academy have remained in the Consortium to further psychoanalysis together, and they continue their friendly and cooperative relationship.

SAMUEL SLIPP

*See also:* American Psychoanalytic Association; New York Psychoanalytic Institute.

### ***Bibliography***

- Alexander, Franz, and Selesnick, Sheldon T. (1966). *The history of psychiatry*. New York: Harper and Row.
- Horney, Karen. (1922). On the genesis of the castration complex in women. In H. Kelman (Ed.) *Feminine psychology*. New York: W. W. Norton, 1967.

Rothgeb, Carrie Lee. (1973). *Abstracts of the standard edition of the complete psychological works of Sigmund Freud*. New York: International Universities Press.

---

## AMERICAN IMAGO

Thirty years after Sigmund Freud's 1909 lectures at Clark University, the psychoanalytic community in the United States had grown large enough to support a psychoanalytic journal focused on culture. *American Imago* had its European antecedent in the psychoanalytic journal *Imago* that was, as Freud tells us, "concerned with the application of psycho-analysis to non-medical fields of knowledge" (1926f, p. 269–70). In Felix Deutsch's obituary for Hanns Sachs, he writes, "When this journal [*Imago*] was suppressed in Europe in 1938, Sachs brought it to life again here in the States" (1947, p. 5). Freud wrote to Sachs that he was initially not pleased with the idea for the journal but that was primarily because it was difficult to "let the light be extinguished completely in Germany" (Gay, 1988, p. 634).

*American Imago* was first published in Boston, Massachusetts, in November of 1939. Russell Jacoby (1983) tells us that Otto Fenichel "reported in deepest confidence that... Sachs was beginning a new magazine, *American Imago*... charged by Freud to rally the classical, and now embattled, analysts" (p. 126). Sachs writes, "when the plan for this periodical was proposed to Freud he greeted it wholeheartedly and consented to become its editor" (1939, p. 3).

Hanns Sachs (1881–1947) assumed editorial responsibilities as publisher and editor, and continued in that role until close to his death. From 1946 until 1963 George Wilbur (1887–1976) was the publisher and managing editor. Harry Slochower noted that Wilbur "kept the broad and deep channels of applied psychoanalysis open in the country," and praises Wilbur's "unassuming generosity which... saved the very existence of the journal" (1967, p. 287). Harry Slochower (1900–1991) came to the journal in 1964 and continued as Editor in Chief until his death. He arranged for the journal to be published by Wayne State University Press, thus expanding *American Imago's* original base in the psychoanalytic community to a wider academic audience. In 1987 Martin Gliserman took over editorial responsibility for the journal; he proposed a new format for the journal and approached Johns Hopkins University Press which began publishing the journal in 1991.

From the very beginning *American Imago* has been an interdisciplinary journal that has examined many fields of study—anthropology, art, film, history, literature, music, philosophy, psychoanalysis, religion, society, and politics. For its part, psychoanalysis has served as a prism through which to view a whole range of cultural works. Thus articles in the journal's first volume addressed such diverse subjects as the ritualized games of verbal insult known as "the dozens," masochism, a play by Shakespeare, anti-Semitism, and mythical heroes. The journal has been responsive over the years to changes in the intellectual climate, and has broadened its psychoanalytic vision, without ever abandoning its original purpose of understanding culture.

MARTIN GLISERMAN

See also: *Imago*; Sachs, Hanns.

### Bibliography

- Deutsch, Felix. (1947). In memoriam—Hanns Sachs 1881–1947. *American Imago*, 4 (2), 3–14.
- Freud, Sigmund. (1926f). Psycho-analysis. *SE*, 20: 261–270.
- Gay, Peter. (1988). *Freud: A life for our time*. New York: W.W. Norton.
- Jacoby, Russell. (1983). *The repression of psychoanalysis: Otto Fenichel and the political Freudians*. New York: Basic Books.
- Sachs, Hanns. (1939). Editorial note. *American Imago*, 1 (1), 3
- Slochower, Harry. (1967). George B. Wilbur at 80. *American Imago*, 24 (4), 287–289.

---

## AMERICAN PSYCHOANALYTIC ASSOCIATION

Despite Sigmund Freud's concern about the fate of psychoanalysis in the United States, it has been the country where psychoanalysis, as theory and as therapeutic enterprise, has been most successful during its first century.

Accompanied by Carl Gustav Jung and Sándor Ferenczi, Freud made his first and only trip to the United States in 1909, visiting Clark University at the invitation of G. Stanley Hall. At that time he received an honorary doctorate in law for his contributions to psychology. This visit came at a time of crisis in sexual

morality following the oppression of Victorian sexuality, a time of change in the structure of American family life with a move towards smaller families, and also at a time of crisis in the treatment of nervous and mental disorders. Facing such pressures, American psychiatrists found the psychoanalytic focus on the emotional relations of love and hate among family members to be revealing and important.

Within ten years of Freud's visit, psychoanalysis was broadly accepted in the United States. At first it was seen as another form of the then-current psychotherapies of suggestion. Its increasing popularity, displacing other therapies, was a result in part of the public's welcome of its optimistic view of mental illness, emphasizing environmental causes and its accessibility to "cure," in contrast to European theories of hereditary degeneration.

The year 1910 was of great importance to the history of psychoanalysis. In his paper "Wild Psycho-Analysis," Freud voiced concern that the use of psychoanalytic notions by those psychoanalytically untrained could be harmful to patients. To protect the public, and the scientific integrity of psychoanalysis, he and his followers founded the International Psychoanalytical Association (IPA), in which membership would be available only to those trained in the psychoanalytic method. Those few Americans who were trained psychoanalysts formed the American Psychoanalytic Association (the American) in 1911. The purpose of the American association, like that of the IPA, was to promote communication and to define what constituted a psychoanalyst in order to protect the public from "wild analysis." Ernest Jones (who would become Freud's first official biographer in the 1950s) had written to Freud that "already in America there are many men exploiting it for financial and other reasons, whose knowledge of the subject is minimal, and who only bring discredit on the work. . . . no one will be elected member of the association unless he has shown some competence in the work."

Freud's continuing concern led, in 1918, to the establishment of an Institute for psychoanalytic education and training in Berlin, with Vienna and London following soon thereafter. These institutes offered a well thought out curriculum that consisted of instruction in the scientific theory of psychoanalysis, supervision in the treatment of patients using psychoanalytic methods, and a personal experience of psychoanalysis. This "tri-partite" form of training came to be the

model throughout the psychoanalytic world: personal analysis, psychoanalysis of patients under supervision, and didactic course work.

That same year also witnessed the publication in the United States of the Flexner report, a startling exposé on the absence of standards in medical education. About half of the existing medical schools were forced to close, and in those remaining, great efforts were made to exorcise charlatans from therapeutic activity and guarantee that a medical degree was the hallmark of proper training and competence. German and Viennese medicine was prestigious at the time, and in attempts to upgrade their standards, Americans looked to them to provide models.

The fields of psychiatry and neurology were also in their formative stages, and since the American conception of medical science was then similar to that of Freud's, that is, a reliance on clinical judgment based on observations made in the individual case, psychoanalysis brought a degree of respectability to psychiatry. On the other hand, the leaders of analysis in New York believed that psychoanalysis gained respectability and prestige from an alliance with medicine and assured it a serious hearing. The American Psychoanalytic Association was eager to retain this respectability, and by 1924, under the influence of the New York Psychoanalytic Society and the concerns secondary to avoiding accusations of quackery, the American had adopted the requirement that members be physicians. Freud and most of the European psychoanalysts protested this change. They believed strongly that psychoanalysis did not belong to medicine. Rather they believed that psychoanalysis was part of a general psychology. The issue of the training of lay analysts was an issue that would persist.

World War I brought prominence to Freud's theories of the irrational and the brutal in human nature. His methods and their derivatives also proved to be the most effective then available for the treatment of "shell shock." Many psychiatrists subsequently became interested in psychoanalysis as a treatment method, and travel to Europe for psychoanalytic education at one of the newly established institutes became popular. On their return, those so trained contributed to the establishment of psychoanalytic societies in several American cities. This began another chapter in American psychoanalysis. Freud maintained that although rigorous training was necessary to become a psychoanalyst, psychoanalytic education and training should be



available to a wider group, not simply to psychiatrists. But the Americans held firm, and among those who had traveled to Europe to train at European institutes, only the psychiatrists were eligible for membership in the American Psychoanalytic Association upon their return. Heated international debate about this policy followed and continued for decades.

By the 1930s, psychoanalytic societies had been established in several cities in the United States. However, it was not until 1931 that the first Institute for Psychoanalytic Education was established. New York's was the first, but Chicago, Boston, and Baltimore-Washington followed shortly thereafter. Once established, these institutes were committed to maintaining the highest possible standards of psychoanalytic education. Thus in 1932, with the reorganization of the American Psychoanalytic Association as a federation of constituent societies, a Council on Professional Training was formed to establish and maintain policies and standards of teaching, so that psychoanalytic education would maintain some consistency as the various institutes were established. In 1938, this council published the "Standards and Principles of Psychoanalytic Education." Although many revisions have taken place, this document remains the definitive statement that guides psychoanalytic education at all constituent Institutes of the American Psychoanalytic Association. The model of education continues to be predominant as the model first established in the first Institute in Berlin. It is a tri-partite model, which includes a personal analysis, psychoanalysis under supervision, and class-work. This has been the core training of all subsequent psychoanalytic Institutes (with a total of twenty-nine by the end of the twentieth century). In 1946 the American Psychoanalytic Association again reorganized. This time two governing bodies were established; a Board on Professional Standards became responsible for all matters of psychoanalytic education, and an Executive Council was established to deal with membership and practice issues.

The years following the World War II again saw increased professional status for psychoanalysts, particularly as derivatives of its methods proved to have the greatest success in treating psychological disturbances brought on by war combat. Furthermore, at a time before psychotropic medications became available, psychoanalysis and its derivative therapies proved among the most successful methods of treating many varieties of mental disturbances. As a result,

psychoanalysis became highly influential in psychiatric education and a large number of university psychiatric residency programs had a psychoanalyst as chairman.

Many have described the years between 1945 and 1965 as the golden years for psychoanalysis in the United States. Psychoanalysis in Europe had barely survived outside of London, and many European analysts had found their way to the United States. This brought a wealth of intellectual energy to American psychoanalysis and interest in the theoretical basis of psychoanalysis enjoyed great popularity. In addition, the patient pool was large, not only because of the dearth of alternative methods, but also because artists and intellectuals felt that engaging in psychoanalytic treatment freed their creative minds. The wealth of clinical experiences led to ever-expanding theories to explain the clinical observations. Nathan Hale points out that during this period the "Popular images of Freud revealed him as a painstaking observer, a tenacious worker, a great healer, a truly original explorer, a paragon of domestic virtue, the discoverer of a source of personal energy and a genius" (1995, p. 289). All of these attributes reflected idealized American cultural values. With such an idealized image of Freud and of psychoanalysis, disillusionment was inevitable. However, one must balance the valid criticisms of the pretensions of psychoanalysis to be a globally explanatory treatment with the attendant and inevitable failure of psychoanalysis to deliver the kinds of idealized expectations that had been established during this "golden age."

An account of psychoanalysis in the United States would not be complete without taking into account the issue that would not go away, that of "lay analysis." Psychoanalytic education in the United States was limited to psychiatrists from the beginning. In 1957 a provision was made whereby psychologists of exceptional research talent could gain access to psychoanalytic education under the proviso that they simply use their psychoanalytic skills to further their research and not attempt to treat patients. However, it was not until 1986 that provisions were made to allow certain non-medical clinicians to gain access to psychoanalytic training. The American Psychoanalytic Association has now reached a point where it is striving to define eligibility for psychoanalytic education on more than the basis of an academic degree.

There were major ramifications to the exclusionary policies of the American Psychoanalytic Association. These policies guaranteed that advancements in the

field of academic psychology would exclude a consideration of psychoanalytic theory because psychologists who might have been interested in the integration of psychology and psychoanalysis were not given access to psychoanalytic education. This meant that psychoanalysis could not benefit from the research methodology available to psychology, and as very little emphasis was given to research in medical education until recent years, psychoanalysis has suffered from the paucity of research which might have offered some validity or reliability to its theoretical positions.

A central event for psychoanalysis in the United States was a class-action anti-trust lawsuit filed in 1985 by four psychologists. This group alleged that the American Psychoanalytic Association, the New York Psychoanalytic Institute, the Columbia University Center for Psychoanalytic Training and Research, and the International Psychoanalytical Association had “restrained and monopolized interstate and international trade and commerce in the training of psychoanalysis and in the delivery of psychoanalytic services to the public” (Schneider and Desmond, p. 322). By 1989, a settlement agreement was approved. The terms of the agreement changed the face of psychoanalysis in the United States: (1) Psychologists and other qualified non-medical clinicians were eligible to train in the institutes of the American. (2) Members of the American were permitted to teach in non-American affiliated institutes. (3) Membership in the IPA was now open to all qualified psychologists and non-medical psychoanalysts. As a result of these changes the American Psychoanalytic Association has become a more inclusive organization. In addition, the American has joined a psychoanalytic consortium with psychoanalytic colleagues in other organizations: Division 39 (Division of psychoanalysis) of the American Psychological Association, the Academy of Psychoanalysis, and the National Membership Committee on Psychoanalysis in Clinical Social Work. This Psychoanalytic Consortium has worked jointly on a variety of social and political issues important to all psychoanalysts, including maintaining the privacy of the psychotherapist-patient relationship, and is working towards the development of a board to accredit institutes from the entire spectrum of psychoanalysis, in order to protect the high quality of psychoanalytic education and psychoanalytic treatment.

One hundred years after the publication of the *Interpretation of Dreams*, and over ninety years since

Freud’s memorable visit to the United States, the American Psychoanalytic Association, in the best Freudian tradition, is once again actively reaching out to psychologists, psychiatrists, mental health professionals, academics, and the lay public. These new endeavors have infused the organization with vitality. With an appreciation of its past, the American Psychoanalytic Association has risen to the challenges of the new century.

LEON HOFFMAN AND SHARON ZALUSKY

*See also:* American Academy of Psychoanalysis; Journal of the American Psychoanalytic Association; Law and psychoanalysis, Lay analysis.

### **Bibliography**

Desmond, Helen, and Schneider, Arnold Z. (1994). The psychoanalytic lawsuit: expanding opportunities for psychoanalytic training and practice. In Robert C. Lane and Murray Meisels (Eds.), *A history of the division of psychoanalysis of the American Psychological Association* (pp. 313–335). Hillsdale, NJ: Lawrence Erlbaum Associates Publishers.

Hale, Nathan G. (1971). *Freud and the Americans*. New York: Oxford University Press.

———. (1995). *The rise and crisis of psychoanalysis in the United States*. New York: Oxford University Press.

---

## **AMNESIA**

The notion of *amnesia* is of neuropathological origin, but for Freud it was not functional defect in the registering of memories. Rather, he looked upon amnesia as a symptom resulting from repression, as a phenomenon which could be circumscribed but which was not a defense mechanism. He compared infantile amnesia to hysterical amnesia, of which in his view it was the forerunner, both forms being connected with the child’s sexuality and Oedipus complex. Amnesia concealed mnemonic traces of traumatic events and, more generally, contents of the unconscious. (When defined by Freud simply as the normal “fading of memories,” [1893a, p. 9] by contrast, the idea of amnesia belonged to the psychology of consciousness rather than to the metapsychology of the unconscious.)

Amnesia was not a psychoanalytical discovery, but, beginning with his earliest psychoanalytical writings, notably the *Studies on Hysteria* (1895d), Freud interpreted it in terms of repression; in the *Three*

*Essays on the Theory of Sexuality* (1905d), he extended the discussion to infantile amnesia.

In the development of Freud's thought, it was the neuropathological idea of amnesia that showed the way to his formulation of repression, even though, structurally speaking, amnesia was a result of repression. The phenomenon of the absence of a memory prompted Freud to posit the existence of an unconscious mnemonic trace. Since he did not consider amnesia to be a defense mechanism, he sought to account for it in another way, namely by the mechanism of repression. Thus in the *Three Essays*, comparing infantile amnesia to the hysterical amnesia that he felt it foreshadowed, he saw both as the outcome of the repression of sexuality, especially childhood sexuality, which he described as polymorphously perverse ("Neuroses are, so to say, the negative of perversions." [p. 165]).

The patient was "genuinely unable to recollect" the "event which provoked the first occurrence, often many years earlier, of the phenomenon in question," which is why it was necessary "to arouse his memories under hypnosis of the time at which the symptom made its first appearance" (1893a, p. 3). The lifting of amnesia was the precondition of the cathartic abreaction of the affects bound to the trauma, the memory of which had been effaced: this was Freud's first theory of the neuroses, namely the theory of the traumatic causality of hysteria.

Amnesia, however, did not in this view succeed in completely wiping out the memory of the trauma, for patients suffered from obsessions, from hallucinatory visions, from what seemed like foreign bodies within their psyches. So long as no abreaction of affects took place, a struggle continued to rage between amnesia and hysterical obsessions, giving rise to "hypnotic states" of a consciousness riven by conflict. Such states might range, according to the strength of the repression, from "complete recollection to total amnesia" (1893a, p. 12). In this light, amnesia could be seen as the ultimate outcome of that defense by means of the "dissociation of groups of ideas" which until 1900 Freud held to be typical of hysteria, and which later he described as the result of repression (an adumbration of the notion of splitting might also be discerned here).

In *The Interpretation of Dreams*, Freud argued that the forgetting of dreams was not "a special case of the amnesia attached to dissociated mental states," for in all cases "repression ... is the cause both of the

dissociations and the amnesia attaching to their psychological content" (1900a, p. 521). As Freud moved from the theory of traumatic hysteria to the theory of dreams, therefore, his conception of amnesia evolved from dissociative splitting to repression.

It was on the basis of the durability of the impression attached to the trauma (concealed by amnesia but finding expression in symptoms) that Freud hypothesized the existence of an indestructible unconscious mnemonic trace, which helps us understand how, to begin with, he had conceived of the mnemonic trace as a so-called "unconscious memory." The German term "*Erinnerungsspur*," whose literal meaning is "memory trace," covered both the (paradoxical) idea of an unconscious memory, which is to say a memory that has succumbed to amnesia, and the idea of an unconscious mnemonic trace.

In 1900 Freud asserted that mnemonic traces were indestructible; in 1895 he had observed that impressions associated with traumatic seductions preserved their sensory intensity and freshness when amnesia protected them from the wearing-away process that they would have undergone had they not been buried in the unconscious. By thus insisting upon the sensory vividness of what amnesia concealed, Freud depicted a quasi-hallucinatory mode of psychic representation consonant on the one hand with a post-traumatic accentuation of impressions that led in particular to the constitution of "mnemonic symbols," and, on the other hand, with his later theoretical claim that unconscious ideas were necessarily figurative in nature.

The notion of amnesia, though it cleared the way for the psychoanalytical notions of the unconscious and of repression, itself remained a phenomenological idea belonging to descriptive psychopathology and marked by the idea of deficiency even if it went beyond it. While amnesia certainly meant a contraction of conscious memory that was not attributable to any functional deficiency of mnemonic fixation, it nonetheless implied a diminution of the capacities of the ego. The forgetting imposed by amnesia (for it was not intentional) was the effect of a defense mechanism that was itself unconscious, namely repression. Such forgetting was experienced, painfully, as consciousness of a repression either under way or already completed; and amnesia could also be the outcome of defense mechanisms other than repression (projection, splitting, foreclosure).

Since new repressions are always in the making, remembering does not make it possible to lift the amnesia completely. In “Constructions in Analysis” (1937d), Freud used the same terminology as in 1895 or 1900, but his standpoint had changed. He continued to think, to be sure, that the aim of analysis, starting, say, from “fragments of [the patient’s] memories in his dreams” (p. 258), was to induce remembering, to lift amnesia. But he now felt that this procedure could never be total and that it could not even be embarked upon unless repetition—notably the manifestation of affective impulses in the transference—was taken into account. Inasmuch as amnesia continued to obscure entire aspects of the past, it was impossible ever to reconstitute that past in its entirety, and the analyst must be content to (re)construct it on the basis of what took place during analysis. This is not to say that Freud abandoned his fundamental historical perspective and embraced fictions, but simply that he redefined interpretation, independently of amnesia and its removal, as “probable historical truth” (p. 261).

This “probable” truth, as opposed to the whole truth, belongs to the episteme of modern history. How can the correctness of a construction be proved? One aspect of such a proof is connected to the set of problems surrounding amnesia and its lifting: communicating an accurate construction to the analysand may on occasion cause a temporary aggravation of the symptoms and the production of “lively recollections . . . described [by the patient] as ‘ultra-clear’” and involving not “the subject of the construction but details relating to that subject” (p. 266).

Infantile prehistory, when the infant can barely speak, was in Freud’s view affected by amnesia in a very particular way, and amnesias coming into play in later years, including hysterical amnesia, were derived from this primary structural amnesia, the concept of which brought Freud close to the idea of primal repression. What appeared as amnesia was indeed sometimes attributable to primal repression. In “A Child Is Being Beaten” (1919e), analyzing an infantile beating-fantasy, Freud emphasized, apropos of its most important phase (being beaten by the father), that “it has never had a real existence. It is never remembered, it has never succeeded in becoming conscious. It is a construction of analysis, but it is no less a necessity on that account” (p. 185). Here amnesia affects not a forgotten event but rather a fantasy about which there is no necessity to claim that it was at one time conscious.

In such cases the amnesia could be removed only partially, as for example when “an elaborate superstructure of day-dreams” (p. 190) represented the fantasy in an indirect way. Here at last the notion of amnesia was completely absorbed by that of repression.

As noted above, “amnesia” is a term belonging to phenomenological psychopathology rather than to psychoanalysis: it refers to the symptom rather than the cause, and it connotes a lack (a-mnesia), which places it close to ideas of deficit. With respect to the psychology of consciousness, it points up the existence of the unconscious in one of its most spectacular effects. But if it opens the door to the metapsychological ideas of mnemic traces and repression, its affiliation with phenomenological psychopathology and cognitive psychology means that it belongs at once to several disciplines: amnesia is involved with the mnemonic “recalling” of information concerning a traumatic area, but a psychogenic causality does not exclude a cognitive or neurophysiological one.

Finally, since amnesia is centered entirely on a reduction of conscious memory, it is not compatible with the later developments in Freud’s thinking on constructions in analysis, although it is true that the accuracy of a construction may bring about the removal of amnesia—thus tending to confirm that Freud never completely abandoned the theory of traumatic seduction and the amnesia to which such a seduction gave rise. In “Remembering, Repeating and Working-Through” (1914g), Freud argued that the “fabric of the neurosis” itself provided “compelling evidence” for the reality of events experienced by the subject “in very early childhood and . . . not understood at the time” (p. 149); in other words, neither the lifting of amnesia nor even a reconstruction of the past was required—a proposition that amounts to a radical refutation of any “verificationist” epistemology. Psychoanalysis is concerned with historical truth, with infantile and psychic realities lying on a different plane, ontologically speaking, from amnesia and that which amnesia conceals, even if the latter can indeed show us the way to the former.

FRANÇOIS RICHARD

*See also:* Black hole; “Claims of Psychoanalysis to Scientific Interest”; Forgetting; Infantile amnesia; Lifting of amnesia; Memory; Mnemic symbol; Mnemic trace/memory trace; Psychoanalytic treatment; Remembering; Reminiscence; Repression.

### Bibliography

- Freud, Sigmund. (1900a). The interpretation of dreams. *SE*, 4–5.
- . (1905d). Three essays on the theory of sexuality. *SE*, 7: 123–243.
- . (1914g). Remembering, repeating and working-through (Further recommendations on the technique of psycho-analysis, II). *SE*, 12: 145–156.
- . (1919e). ‘A child is being beaten’: a contribution to the study of the origin of sexual perversions. *SE*, 17: 175–204.
- . (1937d). Constructions in analysis. *SE*, 23: 255–269.
- Freud, Sigmund, and Breuer, Josef. (1893a). On the psychical mechanism of hysterical phenomena: preliminary communication. *SE*, 2: 1–17.

### Further Reading

- Trewartha, M. (1990). On postanalytic amnesia. *Annual of Psychoanalysis*, 18, 153–174.
- Wetzler, S. and Sweeney, J. (1986). Childhood amnesia: a cognitive-psychological conceptualization. *Journal of the American Psychoanalytic Association*, 34, 663–686.

## AMPHIMIXIA/AMPHIMIXIS

Borrowed from the field of embryology and derived from the Greek (*amphi*: “from both sides”; *mixo*: “mixture”), the term *amphimixia* refers to the fusion of gametes during fertilization and was used by Sándor Ferenczi, beginning in 1924 in *Thalassa: A Theory of Genitality*, as a metaphor for the fusion of erotisms, in order to propose a biology of pleasure.

This elaboration resulted from a method of working by analogies that Ferenczi called “utraquism” (a coinage based on the Latin root *uterque*, meaning “both of them” or “each of them”), or viewing the same thing from two opposite perspectives.

In the language of science, *amphimixia* refers to the fusion of male and female gametes during the process of sexual fertilization, and in *Thalassa* it is extrapolated to describe coitus, the moment of the fusion of erotisms: the mutual identification of the protagonists during foreplay, followed by the dissolving of the limits of the participants’ individual egos; sexual

impotency is described as “genital stuttering” (p. 9); “Everything points to the fact that the urethral (i.e., ejaculatory) tendency is at work from the beginning, throughout the entire frictional process, and that in consequence an unceasing struggle occurs between the evacutory and the inhibitory purpose, between expulsion and retention, in which the urethral element is eventually victorious” (p. 8). Ferenczi continues: “[L]et us term such a synthesis of two or more erotisms in a higher unity the *amphimixis* of erotisms or instinct-components” (p. 9). He describes exchanges in roles, in cases of diarrhea or nervous retention of urine: “[I]n nervous diarrhoea the bowel is inundated by urethrality: while in urinary retention of nervous origin the bladder overdoes the inhibition learned from the bowel” (p. 13n). He points out that “biological science has hitherto taught us nothing about such [displacement] mechanisms as these. As effecting the transition to our assumption of *organic displacement and condensation*, the psychoanalytic investigation of hysteria was of service, in that it demonstrated the displacement of ideational energy upon organic activity and function (conversion) and its retransference back into the psychic sphere (analytic therapy). . . . Each organ possesses a certain ‘individuality’; in each and every organ there is repeated that conflict between ego- and libidinal interests” (p. 82). With regard to female sexuality, the displacement of clitoral eroticism by vaginal eroticism is understood in an analogous way, as a displacement from low to high, as is “the tendency to blushing (the erection of the entire head) on the part of the maiden who represses sexual excitement” (p. 14). In perversion, there is a mixture of oral, anal, cutaneous, and visual erotisms. Further, digressions into the realm of linguistics (the breaks that separate vowels from consonants being compared to certain effects of the sphincter) reveal the ambitious scope of Ferenczi’s project: “to set forth my phylogenetic theory of genitality in the form of a kind of fairy tale” (1936, p. 252), but also as if “sexual intercourse . . . contains a suggestion of mnemonic traces of this catastrophe which overtook both the individual and the species” (p. 254).

*Amphimixia* thus enables Ferenczi, in *Thalassa*, to complement physiopathology with what he terms a “physiology of pleasure” (p. 83), bioanalysis being defined as the “analytic science of life” (p. 93). He emphasizes the significance of regression, noting that the final agonies of death seem to present “regressive trends which might fashion dying in the image of birth and so

render it less agonizing. . . . Death exhibits utero-regressive trends similar to those of sleep and coitus” (p. 95). Finally, he adopts a thoroughly modern viewpoint as he concludes *Thalassa*: “[W]e should . . . conceive the whole inorganic and organic world as a perceptual oscillating between the will to live and the will to die in which an absolute hegemony on the part either of life or of death is never attained” (p. 95).

PIERRE SABOURIN

See also: *Thalassa. A Theory of Genitality*.

### **Bibliography**

Ferenczi, Sándor. (1968). *Thalassa: A theory of genitality* (Henry Alden Bunker, Trans.). New York: Norton Library. (Original work published 1924)

———. (1936). Male and female—Psychoanalytic reflections on the “Theory of Genitality” and on secondary and tertiary sex differences. *Psychoanalytic Quarterly*, 5, 249–60.

---

## **AMPLIFICATION (ANALYTICAL PSYCHOLOGY)**

Amplification is a part of Jung’s method of interpretation of clinical and cultural material, especially dreams. Amplification involves the use of mythic, historical, and cultural parallels in order to clarify, make more ample and, so to speak, turn up the volume on material that may be obscure, thin, and difficult to attend to.

Just as the analyst waits for associations to the dream imagery to reach its personal meanings, so, by amplification, the analyst enables the patient to reach beyond the personal content to the wider implications of her or his material. Thereby, the patient feels less alone and can locate their personal neurosis within humanity’s general suffering and generativity.

Amplification is also a means of demonstrating the validity of the concept of the collective unconscious. Jung’s early understanding of the collective unconscious was that it consisted of primordial images that were, to a large degree, consistent across cultures and historical epochs. As amplification involved the assembly of parallels from diverse sources, it could be regarded as performing this evidential function. Present-day Jungian analysts are far less convinced that universal and eternal images exist.

Amplification is a kind of “natural thinking,” proceeding by way of analogy, parallel and imaginative elaboration. In this sense, it may also be seen as a depth psychological approach to scholarship based on what is claimed to be the natural functioning of the mind, which is not linear and orderly.

Jung first introduced the idea in an essay in a collection edited by Freud in 1908, when he stated that he does not wish the process of interpretation to proceed “entirely subjectively.” In 1935, he spoke of the need to find “the tissue that the word or image is embedded in” (Jung, 1968, p. 84). There he makes the claim that amplification follows a kind of natural “logic.” By 1947, the value of amplification lies in the fact that it can enable us to reach, by inference, the archetypal structures of the unconscious mind which, by definition, are unrepresentable in and of themselves, must be distinguished from their appearance in culture, and which therefore can only be assessed by means of techniques such as amplification (Jung, 1947). Gradually, Jung was coming to see amplification more as a technique to be used in a wide variety of contexts and less as a general principle of mental functioning. Hence, amplification lies behind the immense spreads of cultural and historical material that Jung lays out for his readers.

As the related clinical technique of active imagination was refined, amplification acquired a new significance in Jungian clinical theorizing. If sinking down into the unconscious and recording, often by means of artistic activity, what was encountered therein was not to be merely a self-indulgent, aesthetic process, the role of the ego in amplification was important as a critical agency, not to mention as a bulwark against psychosis.

The clearest statements of the clinical uses of amplification are found in relation to dreams.

Amplification as a concept also had a marked effect on the development of analytical psychology as an institution. If patients were to pursue the parallels to their personal material in terms of cultural material, they needed libraries in which to do this. This was one reason for the creation of analytical psychology “clubs” in urban centers. In the clubs, selected patients and the analysts could relate on more-or-less equal terms, in part united by the need for scholarly resources (Samuels, 1994). The main criticism of amplification has been that it can make analysis into much too intellectual a process and sometimes leads

patients into an inflation whereby they equate their personal situation with something much greater, hence not only avoiding the transference but also gratifying omnipotent fantasies (Fordham, 1978, p. 220).

Amplification needs to be discussed in the context of current debates about interpretation: it is best located as part of a hermeneutical approach rather than a causal-positivist one. Recently, the concept has been extended so as to cover much more of the field of interpretation than Jung intended (Samuels, 1993). The ordinary, everyday analytical procedure of interpreting the patient's material in infantile terms may also be seen as a kind of amplification, neither hermeneutic nor causal-positivist.

ANDREW SAMUELS

*See also:* Word association (analytical psychology); Interpretation of dreams (analytical psychology).

### **Bibliography**

- Fordham, Michael. (1978). *Jungian psychotherapy: A study in analytical psychology*. Chichester, U.K.: Wiley.
- Jung, Carl Gustav. (1947 [1954]). On the nature of the psyche. *Coll. Works* (Vol. VIII). London: Routledge & Kegan Paul.
- Samuels, Andrew. (1993). *The political psyche*. London and New York: Routledge.
- . (1994, April). The professionalization of Carl G. Jung's Analytical Psychology Clubs. *Journal of the Historical and Behavioral Sciences*, XXX, 138–147.

## **ANACLISIS/ANACLITIC**

The idea of anaclisis was introduced by Freud to describe the original relationship, in the young child, between the sexual drives and the self-preservative functions. Arising from a specific site in the organism (an erotogenic zone), the sexual drives at first prop themselves on the self-preservative functions, and only later become independent. The self-preservative function thus sometimes offers its own object to the sexual drive; this is what Freud calls “anaclitic object-choice.”

Like the notion of “deferred action” (*Nachträglichkeit*), that of “anaclisis” or “leaning-on” or “propping” (*Anlehnung*) constitutes a major theoretical concept that always remained latent in Freud's own work. Freud devoted no article or complete discussion to it,

and the notion lay undeveloped in psychoanalysis up until the nineteen-sixties (Laplanche & Pontalis, 1967/1973). An important reason for this inattention is doubtless the fact that the *Standard Edition* did not heed the consistent use of the German word nor translate it in a systematic way; its preferred rendering, moreover, was the artificial “anaclisis.” It has to be said that the concept was not identified either, as such, in Freud's texts or in German psychoanalysis. Since the notion was eminently problematical, and since Freud did not set an example by thinking the matter through, things were simply left fallow.

The German substantive *Anlehnung* is derived from the verb *Sich anlehnung*, meaning to “lean on” or “prop oneself on” (Laplanche, 1970/1976, p. 15–16). The term appears regularly in Freud's work, especially prior to 1920. What it describes is the support that sexuality derives, at the beginning, from various functions and bodily zones related to self-preservation: the mouth, the anus, the musculature, and so on. It is thus intimately bound up with the Freudian conception of infantile and adult sexuality as a much-broadened sphere, far more comprehensive than the genital alone, and indeed extending to the entire body.

The notion made its appearance in the first edition of *Three Essays on the Theory of Sexuality* (1905d), and was further explicated in later revisions of that work. It occurs for the very first time as a designation for the way in which anal sexuality is bound to the excretory function. The most explicit account, however, concerns sucking at the breast: “The satisfaction of the erotogenic zone is associated, in the first instance, with the satisfaction of the need for nourishment. To begin with, sexual activity attaches itself to functions serving the purpose of self-preservation and does not become independent of them until later... The need for repeating the sexual satisfaction now becomes detached from the need for taking nourishment” (1905d, pp. 181–82). “At a time at which the first beginnings of sexual satisfaction are still linked with the taking of nourishment, the sexual instinct has a sexual object outside the infant's own body in the shape of his mother's breast. It is only later that the instinct loses that object... As a rule the sexual instinct then becomes auto-erotic” (p. 222).

According to Freud's description of the component instincts, the bodily source, the aim, and the object of an instinct need to be in a particular term-to-term relationship, on the one hand with respect to self-

preservation, and on the other with respect to sexuality. Freud's account is most explicit apropos of the object: self-preservation may show sexuality the way to the "choice of an object," in which case that choice is made on the model of one of the people important for the child's survival—"the woman who feeds" or "the man who protects." This "anaclitic (attachment) type of object-choice" is contrasted, in "On Narcissism: An Introduction," with "narcissistic object-choice," where the object is chosen on the model of the self (1914c, pp. 87–90).

The idea of anaclisis contains the seeds of an interesting theory of the genesis of the sexual drive. It proposes that this drive definitely develops on the basis of an organic factor, namely the self-preservative function, but that it then detaches itself therefrom, so becoming autonomous, and in the first instance autoerotic, bound to sexual fantasy. This incipient theory was never worked out by Freud: it was firmly rooted in his first theory of the drives (which contrasted sexuality and self-preservation), and its integration into the framework of his "second dualism," that between the life and death drives, would have entailed a complete overhaul of that scheme. Its most troublesome aspect, however, lies in the assumption that the self-preservative and the sexual drives can be treated as comparable, as two parallel yet somehow identical processes. For the very idea of *Anlehnung* implies to the contrary that there is an essential disparity here: the sexual drives are assigned their aims and objects by other processes—by bodily functions or needs—and this implies that sexuality is initially indeterminate.

What Freud's introduction, then his abandonment, of the notion of anaclisis encourages us to do, therefore, is revisit the distinction between the notion of drive (*Trieb*) on the one hand, and that of instinct (*Instinkt*) or bodily function on the other. There are three very different ways of approaching such a task.

A first interpretation posits a sort of developmental parallelism between two types of process, equally biological in nature, as for example nourishment and oral sexuality. According to this model, the operation of self-preservation is seen as triggering erotogenic stimulation. This stimulation is then repeated in an endogenous way (what Freud calls "sensual sucking"). This somewhat mechanical model postulates that the sources, the aims, and even the objects of the two kinds of drives are clearly discernible and discrete, even though, to begin with, they operate in parallel.

A second approach looks upon anaclisis as the correlate of a kind of hatching process, with infantile sexuality functioning in two different ways: at a first moment sexuality props itself upon a bodily function (nutrition, say) even to the point of becoming indistinguishable from it; then, in a second mode, it separates and becomes at once autonomous, autoerotic, and of the nature of fantasy. In the course of this complex transformation, the notions of source, aim, and object undergo a kind of mutation and symbolization. In the case of nourishment, for instance, the object of self-preservation is milk, whereas the sexual object is the breast. From this standpoint, it would be inaccurate to speak of a hallucinatory satisfaction, because the shift from the need for milk to the incorporation of the breast is a movement from the order of need to the order of fantasy and desire.

Thirdly and lastly, it may be objected that this second interpretation is inadequate in that the sexual drive could not arise from physiological functions by means, purely and simply, of some mechanism of "mentalization," some kind of endogenous creation. Rather, it is arguable that the intervention of a sexual other—the adult as opposed to the child—is a primordial requirement if symbolization and sexualization is to take place, if the splitting of sexuality, its binding to fantasy and its functional autonomy, are to be achieved. In this view, it is in the context of seduction that the organic source (the lips, the tongue) comes to be defined as erotic, that the object (the mother's erotogenic breast) imposes itself, and that the aim (for example cannibalistic incorporation) is specified—far beyond the simple ingestion of nourishment.

JEAN LAPLANCHE

*See also:* Erotogenic zone; *Language of Psychoanalysis, The*; Narcissism; Object; "On Narcissism: An Introduction"; Oral stage; Primary need; Primary object; Psychosexual development; Reciprocal paths of influence (libidinal coexcitation); Sucking/thumbsucking.

### **Bibliography**

- Freud, Sigmund. (1905d). Three essays on the theory of sexuality. *SE*, 7: 123–243.
- . (1914c). On narcissism: An introduction. *SE*, 14: 67–102.
- Laplanche, Jean. (1976). *Life and death in psychoanalysis* (Jeffrey Mehlman, Trans.). Baltimore: Johns Hopkins University Press. (Original work published 1970).



———. (1993). *Le fourvoisement biologisant de la sexualité chez Freud*. Paris: Les Empêcheurs de Penser en Rond.

———. (1999). *Essays on otherness* (Luke Thurston, Philip Slotkin, and Leslie Hill, Trans.). London and New York: Routledge.

Laplanche, Jean, and Pontalis, Jean-Bertrand. (1973). *The language of psycho-analysis* (Donald Nicholson-Smith, Trans.). London: Hogarth Press/Institute of Psycho-Analysis. (Original work published 1967)

## ANACLITIC DEPRESSION

The term “anaclitic depression” was coined and promoted by René Spitz. Its first significant mention was in Spitz’s article on “Hospitalism” (1945). The kindred concepts of hospitalism and anaclitic depression are described in chapter 14 of *The First Year of Life* (Spitz and Cobliner, 1965) in the context of a discussion of “The Pathology of Object Relations.” Spitz might be said to have opposed both Otto Rank’s thesis of the “trauma of birth” and the Kleinian idea of the “depressive position” in order to emphasize the study of anaclitic depression, weaning, and the development of the ego.

Spitz’s use of the word “anaclitic” in this connection is in fact rooted in the Freudian notion of *Anlehnung*, or “leaning on,” translated in the Standard Edition as “anaclisis.” The etymological origin of “anaclisis” is the Greek *ana-kleinen*, “to support (oneself) on.” The idea underlying Spitz’s “anaclitic” is thus that of a relational object on which the subject can rely for support in the course of self-construction and self-differentiation; the perspective is the same as Freud’s when he said that object-relationships depended anaclitically on the satisfaction of self-preservative needs. It will be recalled, too, that Freud distinguished between two types of object-choice, the anaclitic and the narcissistic: “there are two methods of finding an object. The first . . . is the ‘anaclitic’ or ‘attachment’ one, based on attachment to early infantile prototypes. The second is the narcissistic one, which seeks for the subject’s own ego and finds it again in other people” (1905d, note added in 1915, p. 222n; see also Freud, 1914c, pp. 87–88).

The anaclitic object plays an important part in Spitz’s theoretical model of the genesis of the object, a model taken up in France by such authors as René Diatkine and Serge Lebovici (1960). It may be defined as that object which the young child uses for purchase as he constructs and discovers his ego and as, at the

same time and as part of the same progression, he passes through the three stages described by Spitz: an objectless stage, a pre-objectal stage, and an objectal stage properly so called. To characterize this object as anaclitic is furthermore quite in harmony with the Freudian notion of anaclisis, for it is through the satisfaction of its self-preservative needs that the baby in Spitz’s model discovers the object and the object-relationship, a relationship that obtains not in the world of needs but in the world of wishes.

There can be no doubt that his extremely fruitful theorizing enabled Spitz, in his time, to propose a model of the genesis of mental representations that was at once developmental and metapsychological, and thus sharply distinct from that of John Bowlby, who has indeed been taken to task for somewhat shortcircuiting the issue of mental representations. At all events, two very different theoretical (and clinical) approaches to depression in infants have resulted.

For Spitz, such depressions are attributable to emotional deficiency—a partial deficiency in the case of anaclitic depression (which is reversible), but absolute in the case of hospitalism (irreversible, at least in principle). Mary Ainsworth (1962; see also Spitz, 1965, p. 267) has reiterated that such situations of emotional deficiency may be described as “quantitative” in that they are the outcome of an absence of the anaclitic object in actual historical reality (i.e., the physical separation of mother and child).

When the anaclitic object is missing from the relational environment, the child’s instincts, and notably its aggressive instincts, are turned against the child itself; it has no external object upon which to focus, and at the same time no sufficiently stable and differentiated internal representation of the object yet exists. The danger of anaclitic depression and hospitalism is thus at its most acute between the ages of one and one-and-a-half, or in other words between the objectless stage and the fully objectal one.

Claims to the contrary notwithstanding, such psychopathological situations are by no means rare, and naturally they are very common during times of social disruption (war, displaced populations, natural disasters, etc.). It is interesting to note, historically speaking, that it was roughly at the same moment, in the immediate aftermath of World War II, that two things happened: no sooner had researchers turned their attention for the first time to the unsuspected abilities of babies, than René Spitz, Anna Freud, Dorothy

Burlingham, John Bowlby, and others described depression, and Leo Kanner autism, in early infancy. It was as though according babies the “right” to a mental life of their own immediately entailed the possibility of their experiencing all the difficulties that inevitably attend any real mental activity: pain and suffering in the case of depression, madness in that of autism or early psychoses.

In more recent times the idea of anaclitic conditions has been widely questioned, even dismissed, yet it is still a point of reference for a good many authors, and there is no denying that it has effectively demonstrated the importance of the quality of the infant’s relationship to the primary object in the construction of the ego, in the emergence of a representational capacity, and in the establishment of a psychosomatic equilibrium.

BERNARD GOLSE

*See also:* Abandonment; Anaclisis/anaclitic; Hospitalism; Neurosis; Repetition.

### **Bibliography**

- Ainsworth, Mary D. Salter. (1962). The effects of maternal deprivation: A review of findings and controversy in the context of research strategy. In Mary D. Ainsworth and R. G. Andry (Eds.), *Deprivation of maternal care*. Geneva: World Health Organization.
- Freud, Sigmund. (1905d). Three essays on the theory of sexuality. *SE*, 7: 123–243.
- . (1914c). On narcissism: An introduction. *SE*, 14: 67–102.
- Lebovici, Serge. (1960). La relation objectale chez l’enfant. *Psychiatrie de l’Enfant* 1, 3, 147–226.
- Spitz, René A. (1945). Hospitalism: An enquiry into the genesis of psychiatric conditions in early childhood. *Psychoanalytic Study of the Child*, 1, 53–74.
- Spitz, René A., and Cobliner, W. G. (1965). *The first year of life: A psychoanalytic study of normal and deviant development of object relations*. New York: International Universities Press.

## **ANAGOGICAL INTERPRETATION**

The idea of “anagogical interpretation”—a kind of interpretation which moves, according to the *Robert* dictionary, “from a literal to a mystical

meaning”—derives from theology. An anagoge is a mystical interpretation that implies spiritual elevation, convergence towards a universal symbolic meaning, and an ecstatic feeling. The notion was promoted by Herbert Silberer, author of *Hidden Symbolism of Alchemy and the Occult Arts* (1914/1971).

Anagogical interpretation relates to the “functional phenomenon” that Silberer defined on the basis of his observation of hypnagogic processes. Silberer described three levels of symbolization: somatic, material, and functional. The “functional phenomenon” pertains to the capacity for symbolic generalization: it facilitates the shift from “material” symbolization of the particular contents of thought to a general symbolization, in images, affects, tendencies, intentions, and complexes that reflect the structure of the psyche.

In psychoanalytic treatment, anagogical interpretation aims at strengthening the tendency to form more and more universal symbols, whose ethical value is also reinforced. Silberer claimed that the functional phenomena were bolstered in the course of an analysis.

This idea of interpretation as a generalizing idealization in the here and now is at odds with the Freudian conception based on the personal dimension, the erogenous zones, and deferred action. Freud recognized the utility of Silberer’s hypotheses for explaining the formation of ideas and the dramatic character of dreams, but he criticized his extension of it to the technique of interpretation (as did Ernest Jones, who likened Silberer’s approach to Jung’s). Freud further rebuked Silberer for falling prey to the defense mechanisms of rationalization and reaction-formation.

JACQUES ANGELERGUES

*See also:* Functional phenomenon; Interpretation; Representability; Silberer, Herbert.

### **Bibliography**

- Freud, Sigmund. (1900a). The interpretation of dreams. *SE*, 4–5.
- Jones, Ernest. (1916). The theory of symbolism. *Papers on psychoanalysis*. Boston: Beacon Press, 1961.
- Silberer Herbert. (1951). Report on a method of eliciting and observing certain symbolic hallucination-phenomena. In David Rapaport, Ed., *Organization and pathology of thought. Selected sources* (pp. 195–207). New York: Columbia University Press. (Original work published 1909)

———. (1911). Symbolik des Erwachens und Schwellensymbolik überhaupt. *Jahrbuch für psychoanalytische und psychopathologische*, 3, 621–660.

———. (1971). *Hidden symbolism of alchemy and the occult arts* (Smith Ely Jelliffe, Trans.). New York: Dover. (Original work published 1914)

## ANALITY

The term “anality” may refer to the second stage of libido development, to a feature of the pregenital organization of the libido, to an aspect of sexual life, or to a salient personality trait. In his letter to Wilhelm Fliess of November 14, 1897, Freud indicated that by adulthood the regions of the mouth and throat and of the anus no longer “produce a release of sexuality” (1950a, p. 279). Their appearance and representation no longer excite, but instead provoke the disgust associated with repression. In *Three Essays on the Theory of Sexuality* (1905d), Freud defined anality as sexual activity in the child that is anaclitically dependent on another physiological function: defecation. The erogenous zone, the zone of attachment of the impulse, is in this case the anal region. This is why certain disturbances of a neurotic origin involve a range of digestive disturbances.

In “Character and Anal Eroticism” (1908b, p. 169), Freud discerned some specifically anal character traits: orderliness, parsimony, and obstinacy. These traits, in his view, are the result of the sublimation of anal eroticism. The handling of money, for example, is clearly connected with an interest in excrement.

In a letter to Dr. Friedrich Krauss (1910f), Freud spoke of the universal tendency of people to “dwell with pleasure upon this part of the body [the anus], its performances and indeed the product of its function” (p. 234). In “The Disposition to Obsessional Neurosis” (1913i), Freud distinguishes passivity, fed by anal eroticism, and activity (mastery), which coincides with sadism. Accentuating this eroticism during the stage of pregenital organization will, during the genital stage, leave men with a significant disposition to homosexuality. When he began his fundamental study “Mourning and Melancholia” (1916–1917g [1915]), Freud wrote, “As regards one particular striking feature of melancholia that we have mentioned, the prominence of the fear of becoming poor, it seems plausible to suppose that it is derived from anal erotism which has been torn out of its context and altered in a regressive sense” (p. 252).

In Freud’s correspondence with Karl Abraham (Freud, 1965a [1907–1926]), the study of melancholic depression was a central theme. Abraham (1927), considered object loss to be an anal process. One form of behavior specific to melancholic depression is an impulse for coprophagy (feeding on feces), which is associated with the oral process typical of introjection and central to melancholy. Abraham went on to claim that anal eroticism embodies two diametrically opposed forms of pleasure. The same opposition can be seen in sadistic impulses. His distinction between two anal-sadistic stages—primitive expulsion (a show of hostility toward the object) and late retention (including tendencies to dominate)—therefore seems fundamental. For Abraham, sexual development after the oral phase went through a second, anal-sadistic, phase, reinforcing the ambivalence that arose during the oral-sadistic substage. This phase itself comprises two substages. The first is characterized by destructive tendencies, while in the second the subject seeks to possess and preserve the object. Freud summarized this approach in his *New Introductory Lectures on Psycho-Analysis* (1933a).

Melanie Klein (1940) adopted Freud’s and Abraham’s conception of depression and mourning, and expanded on it. She treated melancholy as associated with loss of the object and theorized that the archaic character of some pathologies is signaled by the mechanisms of projection and splitting. For Klein (1945), fantasies of emptying the breast and penetrating it to steal its milk, or of attacking it to fill it with fecal matter, underlay paranoid anxieties. Klein then describes the mechanism of projective identification, which is based on earlier work of hers (1955). Through this mechanism, parts of the self empty out into various objects. In this connection, anality assumes central importance in pregenitality and the capacity for sublimation.

Donald Meltzer (1966) makes use of the concepts of the false self and the as-if personality, introduced by Donald W. Winnicott and Helene Deutsch, in his investigation of the features of pseudomaturity, which he associates with anality. Meltzer views anality as a defense against a relation to the breast, and later against the total mother-object.

André Green (1973) suggests that anal regression leads to the destructuring of thought. Primary anality provokes, attacks, and discharges until a state of blank psychosis arises. This approach allows Green (1983) to

distinguish two forms of narcissism: a narcissism associated with the life instinct and a narcissism associated with the death instinct (a negative form of narcissism).

DOMINIQUE J. ARNOUX

*See also:* Activity/passivity; Anal-sadistic stage; Asthma; Character; Coprophilia; Encopresis; Eroticism, anal; Eroto-genic zone; Feces; Gift; Mastery; Modesty; “Notes upon a Case of Obsessional Neurosis” (Rat Man); Obsessional neurosis; Partial drive; Preenital; Psychosexual development; Sadism; Stage; *Three Essays on the Theory of Sexuality*.

### Bibliography

Abraham, Karl. (1927). A short history of the development of the libido. In his *Selected papers on psycho-analysis*. London: Hogarth Press.

Donnet, Jean-Luc, and Green, André. (1973). *L'enfant de ça*. Paris: Minuit.

Freud, Sigmund. (1905d). Three essays on the theory of sexuality. *SE*, 7: 123–243.

———. (1908b). Character and anal erotism. *SE*, 9: 167–175.

———. (1910f). Letter to Dr. Friedrich S. Krauss on Anthropophyteia. *SE*, 11: 233 ff.

———. (1913i). The disposition to obsessional neurosis: A contribution to the problem of choice of neurosis. *SE*, 12: 311–326.

———. (1916–1917g [1915]). Mourning and melancholia. *SE*, 14: 237–258.

———. (1933a [1932]). New introductory lectures on psycho-analysis. *SE*, 22: 1–182.

———. (1950a [1887–1902]). Extracts from the Fliess papers. *SE*, 1: 173–280.

———. (1965a [1907–1926]). A psycho-analytic dialogue: The letters of Sigmund Freud and Karl Abraham, 1907–1926 (Bernard Marsh and Hilda C. Abraham, Trans.). New York: Basic Books.

———(1985c [1887–1904]). *The complete letters of Sigmund Freud to Wilhelm Fliess, 1887–1904* (Jeffrey M. Masson, Trans.). Cambridge, MA: Belknap/Harvard University Press, 1985.

Green, André. (2001). The dead mother. In his *Life narcissism, death narcissism* (Andrew Weller, Trans.). New York: Free Association Books. (Original work published 1983)

Klein, Melanie. (1940). Mourning and its relation to manic-depressive states. *International Journal of Psycho-Analysis*, 21, 125–153.

———. (1945). The Oedipus complex in the light of early anxieties. *International Journal of Psycho-Analysis*, 26, 11–33.

Klein, Melanie; Heimann, Paula; and Money-Kyrle, Roger (Eds.). (1955). *New directions in psycho-analysis: The significance of infant conflict in the pattern of adult behaviour*. London: Tavistock Publications.

Meltzer, Donald. (1966). The relationship of anal masturbation to projective identification. *International Journal of Psycho-Analysis*, 47, 335–342.

## ANAL-SADISTIC STAGE

The anal-sadistic stage, the second type of organization of libidinal cathexes, instates the anal zone as the predominant erotogenic zone during the second year of life. The relation to the object during this period is shot through with meanings relating to the function of defecation (expulsion or retention) and to the symbolic value of feces (given or refused).

Freud saw the conflicts of this stage as defining for the sadomasochistic object-relationship and its three characteristic dichotomies: activity/passivity, domination/submission, and retention/expulsion.

The anal-sadistic stage takes form during the second year of life, which is devoted to the mastery of the object and the development of the “drive for mastery.” Anal erotism, anaclitically attached to the retention or evacuation of feces, becomes conflicted during this stage.

The erotogenic zone involved is not confined exclusively to the anal orifice, but extends to the whole ano-recto-sigmoidal mucosae and even to the digestive system as a whole and to the musculature responsible for retention and evacuation. The instinctual object cannot be reduced solely to feces to be retained within the body or expelled into the outside world, for during this time the mother and people around her also function as partial objects to be mastered and manipulated.

The instinctual aims of this period are twofold: to gain erotic pleasure linked to the erotogenic zone and mediated by stools and to explore ways to manipulate and master the mother, who is now beginning to be differentiated. “The child looks upon its stools as a part of itself that it may either expel or retain (a gradual differentiation between inside and outside) and

that thus becomes a medium of exchange between itself and the adult” (Golse, 1992).

Freud placed special emphasis on the symbolic meanings of giving and withholding attached to the activity of defecation. He showed how anal erotism, which is linked to both destructive expulsion and conservative retention, assigns to feces the role of a part-object that the child can use either to please or to challenge the mother. “Defaecation affords the first occasion on which the child must decide between a narcissistic attitude and an object-loving attitude. He either parts obediently with his faeces, ‘sacrifices’ them to his love, or else retains them for purposes of auto-erotic satisfaction and later as a means of asserting his own will” (Freud, 1917c, p. 130). Freud went on to stress the symbolic equivalence of feces, gifts, and money. This equivalence was further extended with the notion of a “little, detachable part of the body” (excrement, the penis, and the baby) that can stimulate a mucosal passage by entering and leaving it. These parts, as detachable parts of the body, are symbolically interchangeable. It is worth noting that even before describing the anal-sadistic pregenital organization, Freud had earlier made a connection between certain character traits in adults (love of order, avarice, and obstinacy) and the child’s anal erotism (1908b).

Following Freud’s lead, Karl Abraham (1927, pp. 422–433) proposed to divide the anal-sadistic stage into two phases on the basis of two contrasting kinds of behavior with respect to the object. In a first, expulsive phase, dependent on the musculature, auto-erotism is associated with evacuation. This period is sadistic in the sense that the expulsion of the destroyed object also acquires the meaning of an act of defiance toward an adult. A second, retentive phase is passive and masochistic in character. The instinctual aim here is mastery of the object, which implies its preservation. This phase is masochistic in that it involves an active search for pleasure through painful retention and dilation of the mucous membranes and anal canal.

The anal stage is thus a time of ambivalence par excellence, when the same fecal object may be either preserved or expelled, and may thus underpin two quite different types of pleasure and assume the qualities by turns of a good or bad object.

For Abraham (1924/1927, p. 433), the dividing line between the first and second phases of the anal stage correspond to the boundary between psychosis and neurosis. In his view, in the psychoses the object is

expelled and lost, whereas in obsessional neurosis it is withheld and preserved. In the neuroses, preservation of the object implies that retention wins out over expulsion and that ambivalence is resolved, with the result that there are fewer splits of various kinds. This underscores the role of an obsessional organization in maintaining the link to the object.

In *The psycho-analysis of children* (1932/1975, pp. 144–146), Melanie Klein described anal-sadistic fantasies in which objects (and the subject too, by way of the law of talion [an eye for an eye]) are attacked by poisoned or explosive fecal matter.

JEAN-FRANÇOIS RABAIN

See also: Anality; Demand; Imago; Stage (or phase).

### Bibliography

Abraham, Karl. (1927). A short study of the development of the libido, viewed in the light of mental disorders. In *Selected papers of Karl Abraham, M.D.*. London: Hogarth. (Originally published 1924)

Freud, Sigmund. (1908b). Character and anal erotism. *SE*, 9: 167–175.

———. (1917c). On transformations of instinct as exemplified in anal erotism. *SE*, 17: 127.

Golse, Bernard. (1992). *Le développement affectif et intellectuel de l’enfant*. Paris: Masson.

Klein, Melanie. (1975). *The psycho-analysis of children* (Alix Strachey, Trans.; revised by H. A. Thorner). Vol. 2 of *The writings of Melanie Klein*. London: Hogarth and the Institute of Psycho-Analysis. (Originally published 1932)

---

## ANALYSAND

During the earliest days of psychoanalytic practice, Freud and his students, excited by their discoveries, put great emphasis on the active role of the psychoanalyst. Even though he showed himself to be less of an inquisitor than in the *Studies on Hysteria*, it was the analyst who intervened, interpreted, “analyzed,” and the patient was, at least in theory, the person on whom some form of therapeutic activity was practiced. The patient was the “analysand” of a psychoanalyst, who possessed the necessary theoretical knowledge from having first “undergone” the initiatory experience of psychoanalysis himself.

British authors were the first to use the gerundive form “analysand” to refer to the patient in analysis. The term is found as early as 1925 in the *International Journal of Psycho-Analysis* and was regularly used by English authors before the Second World War. As psychoanalysis developed and spread, and as increasing emphasis was placed on the transference and countertransference in the dynamics of therapy, the patient turned out to be at least as, and sometimes more, active than the analyst. In 1972 Joyce McDougall created the term “anti-analysand.”

ALAIN DE MIJOLLA

*See also:* Framework of the psychoanalytic treatment; Psychoanalytic treatment; Technique with adults, psychoanalytic.

### **Bibliography**

McDougall, Joyce. (1972). L'anti-analysant en analyse. *Revue française de psychanalyse*, 36, 167–206.

---

## **ANALYSE QUATRIÈME.** *See* Fourth analysis

---

### **“ANALYSIS OF A PHOBIA IN A FIVE-YEAR-OLD BOY” (LITTLE HANS)**

This important publication of 1909 was the first case study in which clinical material, derived directly from the treatment of a child, was presented as evidence in support of Sigmund Freud's theories of infantile sexuality. The somewhat unorthodox treatment was carried out by the child's father under the “supervision,” mainly by way of letters, of Freud himself.

This case study played a significant role for Freud in consolidating his new theories concerning infantile sexuality. While his major findings about the existence of the Oedipus and castration complexes, and the sexual life and theories of children, had originally been derived from the analysis of adults, the case of “Little Hans” (as it has come to be called in the psychoanalytic literature) provided the independent “proof” Freud needed, using clinical material obtained from a child. The case of Little Hans delivered compelling clinical examples which confirmed many of the theoretical statements made in the *Three Essays*

*on the Theory of Sexuality*, which Freud had published in 1905, and which were, at that time, regarded as scandalous.

Little Hans, whose father had been sending Freud reports about his son's interest in sexual matters and his curiosity about his body and the bodies of others—an interest centered especially upon the anatomical differences between the sexes—suddenly developed a phobia (an infantile neurosis). He refused to leave the house and go into the street for fear of being bitten by a horse. The paper “The Analysis of a Phobia in a Five-Year-Old Boy” is the account of the development, the interpretation, the working through, and partial dissolution of the neurotic conflicts from which the phobic symptom originated. This first “child analysis” was conducted, with “supervision” from Freud, by Max Graf, Hans's father, an early follower of Freud's. His wife, Hans's mother, had been in analysis with Freud, while Graf was a participant in the Society's Wednesday meetings.

Freud had Hans and his father in to see him, and realized that the details of the appearance of the horse that so frightened the boy stood in fact for the eye-glasses and moustache of the father. Freud's revelations prompted Hans to ask his father, “Does the Professor talk to God, as he can tell all that beforehand?” (p. 42–43) Freud indeed played the *éminence grise* in this story, and the father reported several times to Freud that Hans had requested him to convey this or that fantasy to him, apparently secure in the feeling that “the Professor” would know how to interpret them.

What the case of Little Hans documented were the now well-known elements of the phallic-oedipal phase of sexual development. Evident were the high esteem in which the penis is held by the child as a source of pleasure; the love of the parent of the opposite sex and the rivalry with the (otherwise loved) same sex parent; the pleasures of looking and being looked at; persistent thoughts about the parents' sexual activities, about pregnancy and birth; and jealousy, death wishes, and castration anxiety.

The case study cannot however be seen simply as a description of a specific clinical syndrome or as the extension of analytic technique to children. It also made clear for the first time, as Anna Freud (1980) pointed out, the complexity of the child's emotions and thinking, and graphically illustrated how inner conflicts arise through the mutually contradictory demands of the drives, the developing ego and

superego structures, and the external world, and how this process can be accompanied by compromise formations in the form of neurotic symptoms. The paper documents the arduous task for the still immature ego of finding compromise solutions to these conflicts. The publication is also considered to be an important step in closing the gap between pathology and normality, between psychic health and psychic illness.

The case study of “Little Hans” proved to be the forerunner of the development of child analysis (in the work of Anna Freud in Vienna and London and Melanie Klein in Berlin and London) and the direct observation of children.

Freud’s explanation of the outbreak of Little Hans’s phobia is as follows: the phobic symptom, that a horse might bite him or fall down, was a compromise formation which was developed in an attempt to solve the oedipal conflict, with which he was struggling. Hans’s sexually excited attachment to his mother and his ambivalent feelings towards his father, whom he loved deeply, but who stood in his way as a rival for the reciprocation of love from his mother, gave rise to castration anxiety and the fear of being punished, as well as to guilt feelings and to repression. The birth of his sister heightened the conflict as she too was seen by Hans to be a rival for his mother’s attention and affection. Hans was able quite openly to express his death wishes towards his sister—but the repression of his aggressive impulses towards his father strengthened his castration anxiety and forced him—through the mechanisms of displacement and externalization—to create a phobic object which could be avoided. In this way Hans’s inner conflict was converted into an external danger, which he could escape through flight. He was thus able to ward off an even greater anxiety, that of castration. The development of the phobic symptom fulfilled the function of helping to maintain Little Hans’s psychic balance.

VERONIKA MÄCHTLINGER

See also: Graf, Herbert; Graf, Max; Infantile neurosis; *Inhibitions, Symptoms, and Anxiety*; Oedipus complex; Phobias in children; *Psychoanalytic Treatment of Children, The*.

### Source Citation

Freud, Sigmund. (1909b). Analyse der Phobie eines fünfjährigen Knaben (“Der kleine Hans”) *Jb. psychoanal. psycho-*

*pathol. Forsch*, I, 1–109; *GW*, VII, p. 241–377; Analysis of a phobia in a five-year-old boy. *SE*, 10: 1–149.

### Bibliography

Freud, Anna. (1980). Introduction. In the paperback edition of *The analysis of a phobia in a five-year-old boy*. Frankfurt am Main: S. Fischer.

Freud, Sigmund. (1905d). Three essays on the theory of sexuality. *SE*, 7: 123–243.

———. (1922c). Postscript to “Analysis of a phobia in a five year old boy.” *SE*, 10: 148.

## “ANALYSIS TERMINABLE AND INTERMINABLE”

In response to Rank’s proposal of providing shorter cures, Freud, using the example of the Wolf Man, makes the central theme of this article the duration of the treatment and “the part of the transference which had not been resolved” (p. 218). The problem of the slow progress of an analysis “leads us to another, more deeply interesting question: is there such a thing as a natural end to an analysis?” (p. 219). A terminated analysis supposes that two conditions are fulfilled: first, the patient must be relieved of symptoms, inhibitions, and anxieties, and second, enough of the repressed must be made conscious and elucidated, and enough of the resistance conquered, so as to banish the risk of repetition.

Three factors affect the length of a treatment: “the constitutional strength of the drive,” “traumas,” and the “alteration of the ego” (pp. 220–221). Freud indicated that if the traumatic factor is preponderant, the situation favors progress towards a “definitively terminated” analysis (p. 220). Two factors are responsible for interminable analyses: “the constitutional strength of the drive” and “an unfavorable alteration of the ego acquired in the defensive struggle” (pp. 220–221) that results in a kind of dissociation or restriction of the ego.

To follow dialectical reasoning by opposing a “terminated analysis” to an “interminable” one might not be of use for theoretical research on the end of analysis. Too much stubbornness on this point could reinforce a somewhat ideological position consisting, as Freud wrote in “Remembering, Repeating and Working-Through,” “in resolving every one of the patient’s repressions” and “in filling all the gaps in his memory” (1914g, p. 220). A failure to achieve this end could result from the constitutional strength of the drive being rooted in biology.

In 1937, the metapsychological model explained most closely the economic and dynamic aspects of clinical experience, aspects that had previously eluded explanations using the notion of opposition of forces. Thus the end of analysis was described by means of a much more complex psychic apparatus involving both the first and second topographies, as well as two classes of drives that place the “psychic conflict” at the center of mental functioning.

When drive is mentioned in this late work, it must be understood in the context of a two-drive model, whether in its relation to the object or to the ego. The pressure of the drives is countered by the ego, which sets up a resistance using various defenses, some of which, as “reaction-formations,” constitute the louder aspects of neurosis. Though Freud used the term “transference-love,” Eros is not the only component in the dynamics of the transference. Various obstacles face the analysis, with the risk of a negative therapeutic reaction always on the horizon. These negative developments might be moderate during the analysis only to flare up at full intensity after its termination.

On the basis of two examples, Freud implicitly introduced two essential ideas regarding the end of the treatment. The first concerns what would now be called the counter-transference in relation to a young female homosexual. The second idea involves the time of exploration necessary for the numerous returns of negative currents.

This article implicitly links the themes of psychic conflict, failure to achieve completion, the negative, and counter-transference. Resistance to the loss of the object and to the constitution of masculine and feminine identifications is grounded in the dynamics of the binding of the two drives, itself influenced by the transference and the analyst’s interpretations.

In this work, Freud did not directly raise the issue of the analysand’s desire to become an analyst, although he very probably was referring to Sándor Ferenczi when he mentions the belated disclosure of the negative transference. The remnant of negative transference that is the desire to become an analyst was made the subject of a study by Jean-Paul Valabrega concerning analytic training (1994).

The negative current is one working perspective outlined by Freud in this late text. Several subsequent authors, each in their own way, revisited the question of the negative. As different as their works might be, one common point becomes clear, namely that an analysis,

even in the favorable case of a transference neurosis, confronts the protagonists with the play of binding and unbinding of the drives and with inevitable negative phenomena. The length of treatment, which has increased over time, is due, in large part to a wish to analyze the negative currents, particularly in the transference.

RENÉ PÉRAN

*See also:* Biological bedrock; Cure; Ferenczi, Sándor; “From the History of an Infantile Neurosis” (Wolf Man); Negative therapeutic reaction; Psychoanalytic treatment; Technique with adults, psychoanalytic; Termination of treatment; Therapeutic alliance.

### Source Citation

Freud, Sigmund. (1937c). Die endliche und die unendliche Analyse. *GW*, 16; Analysis terminable and interminable. *SE*, 23: 209–253.

### Bibliography

- Aulagnier, Piera. (2001). *The violence of interpretation: from pictogram to statement* (Alan Sheridan, Trans.). East Sussex, Philadelphia: Brunner-Routledge. (Original work published 1975)
- Freud, Sigmund. (1914g). Remembering, repeating and working-through (Further recommendations on the technique of psycho-analysis II). *SE*, 12: 145–156.
- Green, André. (1999). *The work of the negative* (Andrew Weller, Trans.). New York: Free Association. (Original work published 1993)
- Guillaumin, Jean. (1987). *Entre blessure et cicatrice*. Seyssel: Éditions Champ Vallon.
- Valabrega, Jean-Paul. (1994). *La formation du psychanalyste*. Paris: Payot.
- Zaltzman, Nathalie. (1986). Baiser la mort, une sexualité mélancolique. *Topique*, 38.

---

## ANALYTIC PSYCHODRAMA

There is a distinction to be made between psychodrama, a method of investigating psychic processes by dramatizing improvised scenes staged and acted by a group of participants, and “analytic psychodrama,” a form of analytic psychotherapy that uses a play and its dramatization as a means of elucidating unconscious phenomena. In analytic psychodrama the emphasis is on the interpretative function of the play: a play leader analyzes transference and resistances. The drama



presented in the play is an invitation to engage in symbolizing, which is often fragile in the kind of patient for whom this therapy is intended.

Psychoanalysis is indebted primarily to Jacob Levy Moreno (1889–1974) for the remarkable insight of deploying theatrical improvisation and its dramatization in plays in the service of psychoanalysis. He continually combined his psychiatric training with his training as an actor to open up new modes of expression that used lively dialogue and developed a rediscovered spontaneity. He anticipated that such a catharsis would lead to an emotional release, facilitated by body language. Later he moved on to a more specific study of interpersonal group relations, which subsequently formed the basis for his theory of roles and interaction (sociometry).

After the Second World War, interest in theories about groups and group methods developed rapidly and found a particularly favorable reception in France. In the wake of the work of Georges Heuyer in child psychoanalysis and Mireille Monod in psychodrama, Serge Lebovici undertook the first analytic psychodramas with children. He based his practice on psychoanalytic findings and thereby instigated the gradual process by which psychodrama, founded on Moreno's theories, became established. Informed by a wealth of observations, the field of psychodrama then grew and was extended to adult psychotherapy.

In Great Britain, the Tavistock Clinic was the source of group therapies, which benefited from Wilfred R. Bion's remarkable contribution. In the United States, group therapy and psychodrama became particularly fashionable, with the American Society for Group Psychotherapy and Psychodrama in New York as its starting base. In Argentina, following the years of repression under the military dictatorship, psychodrama underwent a new expansion. In particular, an association for psychodrama and group psychotherapy was founded there in 1963. Psychodrama also began to emerge in Russia, Czechoslovakia, and Vietnam, where it remains strongly characterized by Moreno's influence.

In practice, an analytic psychodrama is centered around a theme suggested by a patient, which is acted out by him and the other participants. Instead of the free associations used in classical treatment, the patient is invited to act out and stage everything that comes to mind with the help of the other actors. Anything can be acted out, though it has to remain in the realm of the play. Through the reaction that it

produces, the play resuscitates what is often a deficient psychic dynamic. The drama enacts and accomplishes the following:

- The dramatization of conflicts. Affect is connected with words and gestures, which allows the drives to be based in the body.
- Access to representability. The drama enacted by the actors and the interpretation provided by the play leader facilitate the formulation of otherwise inexpressible anxieties and thereby suggest representations often containing affects that are painful to the patient's ego.
- Mediation through the play. By reducing the influence of censorship, the fiction created by the play lifts certain inhibitions and facilitates access to unconscious conflicts. The enjoyment of the play reinforces the subject's narcissism and his confidence.

There are many varieties of psychodrama, which bears witness that the practice is evolving, creative, and receptive. There is the form of group psychodrama in which the theme is one shared by the whole group and is interpreted accordingly. There are also two main varieties of psychodrama with individual themes: individual psychodrama and group psychodrama. In these latter two types of psychodrama, a patient or group of patients meets with a team of therapists. In either case, the theme is always individual, as is the resulting interpretation. There are three types of participant in psychodrama: the patient, who chooses the scene, a character to play, and the roles to be assigned to the other actors; the other actors, who act out the suggested scene (their acting has a primarily interpretative purpose, being closest to the unconscious impulses expressed by the patient); and the play leader, who does not act but interprets and makes connections between the meaning of the different scenes. The play leader also assists in the staging and reinforces the setting. To the play leader falls the task of interpreting the transference.

Whether the use of analytic psychodrama is indicated depends more on the patient's mode of functioning than on nosographic categories. Psychodrama is more often recommended for patients who suffer from sensory deprivation or rigid defensive procedures, who are deficient in their ability to fantasize, or who harbor dominant psychotic fears. Furthermore, since psychodrama was first used in treating child and

adolescent pathologies, it continues to be the treatment of choice for young patients.

NADINE AMAR

*See also:* Idea/representation; Moreno, Jacob Levy; Psychotherapy; Symbolization, process of; Technique with adults, psychoanalytic; Technique with children, psychoanalytic.

### **Bibliography**

- Amar, Nadine; Bayle, Gérard; and Salem, Isaac. (1988). *Formation au psychodrame analytique*. Paris: Dunod.
- Anzieu, Didier. (1956). *Le psychodrame analytique chez l'enfant*. Paris: Presses Universitaires de France.
- Gillibert, Jean. (1985). *Le psychodrame de la psychanalyse*. Paris: Champ Vallon.
- Jeammet, Philippe, and Kestemberg, Evelyne. (1987). *Le psychodrame psychanalytique*. Paris: Presses universitaires de France.
- Moreno, Jacob Levy. (1946–1969). *Psychodrama* (3 vols.). New York: Beacon House.
- . (1947). *The theater of spontaneity: An introduction to psychodrama*. New York: Beacon House.
- . (1959). *Gruppenpsychotherapie und Psychodrama: Einleitung in die Theorie und Praxis*. Stuttgart, Germany: G. Thieme.

## **ANALYTICAL PSYCHOLOGY**

Founded by Carl Gustav Jung, the field of analytical psychology is the descendent of the “Zürich School” of psychoanalysis which Jung spearheaded while still the heir apparent to Freud and the first president of the International Psychoanalytic Association (1910–1914).

The first written occurrence of the name “analytical psychology” is in a lecture delivered by Jung to the Psycho-Medical Society in London on August 5, 1913 (“General Aspects of Psychoanalysis”). Conceived by Jung as a general (depth) psychology, the field grew in size and developed in complexity both during Jung’s lifetime and after his death in 1961. By 1997 it had come to embrace some two thousand professional analysts on five continents.

In the years 1907–20 Jung worked out the main outlines of his theory, which set the course for analytical

psychology. By the end of this period, the theory included psychological types, the theory of complexes and archetypes, the notions of persona, shadow, and anima/animus, and the individuation process.

Among the factors that have distinguished analytical psychology are: (a) a synthetic/symbolic component in analytic treatment; (b) a view of libido that includes a broad range of instinct groups, as well as a theory of culture that sees it based not on sublimation of sexuality but on symbolic transformation processes native to the psyche; (c) a notion of the unconscious that includes strivings toward growth and development, intelligent purpose, and orientation to meaning rather than narrowly limited to a pleasure orientation and a drive to tension release; (d) minimization of the psychosexual stages of development in childhood in favor of lifelong psychological development.

Technique also contributes important distinguishing features to analytical psychology: (a) while retaining a strong sense of the importance of transference and regression, Jung placed patients in a chair vis-à-vis the analyst and asked them to interact and maintain a dialogue; (b) frequency of sessions is variable from twice to five times per week, depending on the need; (c) the personality of the analyst as well as the analyst’s associations (“amplifications”) to dreams and other unconscious material come into play in a more open and explicit fashion, and the analyst seeks to be somewhat transparent and self-disclosing of emotional reactions.

Already when Jung broke with Freud at the end of 1912 he enjoyed an international reputation and quickly attracted his own students from many parts of Europe and the United States. These men and women typically returned to their countries of origin and began Analytical Psychology Clubs or similar study groups in their home cities: London (1922), Paris (1926), New York (1936), San Francisco (1939), Los Angeles (1942), Tel Aviv (1958). Interest in Jung’s ideas was strong also in Berlin, but since many of the physicians drawn to him were Jewish (Gerhard Adler, Ernst Bernhardt, Werner Engel, Jean Kirsch, Ernst Neumann) and fled to the United States, England, Italy, and Israel during the 1930s, and because of the Nazi rise to power and the outbreak of World War II, the founding of a Jungian organization in Germany was delayed until 1962.

Gradually these Analytical Psychology Clubs fostered professional analyst societies which, after the

Second World War, began sponsoring training institutes. The Society of Analytical Psychology, London (1945) led by Gerhard Adler, Michael Fordham, and Edward A. Bennett founded the first training program. Next came the Carl Gustav Jung Institute/Zürich (1948) with Carl A. Meier as President. In the 1960s, training institutes appeared in many parts of the world: Italy (1961), New York (1962), Germany (1962), San Francisco (1964), Los Angeles (1967), and France (1969). In the following decades, professional societies and training institutes also developed in Austria, Australia/New Zealand, Brazil, Israel, South Africa, and many urban centers in the United States. By 1996 there were twenty-three training institutes in existence worldwide.

The International Association for Analytical Psychology (IAAP), founded in 1955 to serve as an international umbrella organization for all professional analyst groups within the field of analytical psychology, provides a network of communication and collegiality for Jungian analysts throughout the world. There are presently thirty-two member groups of IAAP. Every three years the IAAP sponsors a Congress and publishes the papers presented. The Zürich Congress of 1995 was the thirteenth to be held.

As the field of analytical psychology developed, it experienced a vigorous display of diversity and polarization. The issue that has most divided it is the same one that originally caused the rupture between Jung and Freud: a symbolic, prospective approach to interpretation and clinical practice vs. a reductive one. Within analytical psychology this has been referred to variously as the Zurich vs. London, the classical vs. developmental, or the symbolic vs. clinical tension. In every version of this debate, the questions revolve around whether to give more prominence to working synthetically and symbolically with dreams and other direct manifestations of the unconscious or to devote one's efforts exclusively toward technique and the analysis of personal issues involving early childhood and developmental traumas, resistance, and transference. The classical school bases itself centrally on the writings of Jung and his close followers such as Marie Louise von Franz, Carl A. Meier, and Edward Edinger, while the developmental school incorporates many ideas from modern psychoanalysis, particularly object relations theory. The leading figure of the latter movement was Michael Fordham. The most recent generation of analysts has attempted to synthesize these two

opposing trends and to find a balanced approach. Some have carried out investigations of the character disorders, dissociative states, and the interactive field (transference-countertransference). There have also been movements in recent decades to apply analytical psychology to the analysis of children and adolescents, society and politics, art and popular culture, small groups and large corporate organizations, and marriage and family dynamics.

Scientific studies testing the hypotheses of analytical psychology continue in many universities and institutes throughout the world. Journals of analytical psychology appear regularly in English, French, German, Italian, Japanese, Korean, and Portuguese. The most important of these are: *The Journal of Analytical Psychology* (London, est. 1955), *the Cahiers Jungiens de Psychanalyse* (Paris, est. 1974), and *the Zeitschrift für Analytische Psychologie* (Berlin and Zürich, est. 1969).

MURRAY STEIN

*Notions:* Active imagination (analytical psychology); Alchemy (analytical psychology); Amplification (analytical psychology); Animus-Anima; Archetype (analytical psychology); Collective unconscious (analytical psychology); Compensation (analytical psychology); Complex (analytical psychology); Ego (analytical psychology); Extroversion/introversion (analytical psychology); Individuation (analytical psychology); Interpretation of dreams (analytical psychology); Midlife crisis; Numinous (analytical psychology); Projection and "participation mystique" (analytical psychology); Psychological types (analytical psychology); Self (analytical psychology); Shadow (analytical psychology); Synchronicity (analytical psychology); Transference/counter-transference (analytical psychology); Word association (analytical psychology).

*See also:* Belgium; Brazil; France; Germany; Great Britain; Jung, Carl Gustav; Netherlands; Switzerland, (German-speaking).

### **Bibliography**

- Dyer, Donald. (1991). *Cross-currents of Jungian thought: An annotated bibliography*. Boston-London: Shambhala.
- Henderson, Joseph L. (1995). Reflections on the history and practice of Jungian analysis. In Murray Stein (Ed.): *Jungian analysis*. La Salle, IL: Open Court.
- Jung, Carl Gustav. (1966). *Memories, dreams, reflections*. London: Routledge. (Original work published 1962)

Samuels, Andrew (1985). *Jung and the Post-Jungians*. London-Boston: Routledge.

Stein, Murray (Ed.). (1995). *Jungian analysis*. La Salle, IL: Open Court.

## ANALYZABILITY

The concept of “analyzability” appeared late in the psychoanalytic literature and has two different meanings: One was the classical designation, following the medical model, concerning “indications and contraindications” of the psychoanalytic treatment; the other referred to the realization of a limit to interpretation, that is, the recognition that there is an “analyzable” element and an “unanalyzable” element in what the psyche produces. It was the abandonment of the strict medical model and the attempt to take into account purely psychoanalytic factors that led to the emphasis, when discussing the progress of an analysis, on the concept of analyzability. Preliminary interviews are intended to estimate and, depending on the psychopathology of the patient and his capacity for insight, orient the choice of therapy toward a conventional treatment or psychotherapeutic treatment. Some authors, like Elisabeth Zetzel (1968), have, for example, classified hysterical patients into four categories based on their “analyzability.” Other authors, especially when discussing borderline patients, have tried to define precise criteria for prognosis. These include Otto Kernberg, who feels that the ability to experience guilt is “a good prognostic sign in the evaluation of the ‘narcissistic personality’s’ analyzability” (1970). The majority of authors, however, although they do not recommend the use of trial treatments as Heinz Kohut did (1971), following Freud, recognize that the only way to judge a patient’s receptivity to analysis is through the process of analysis itself.

The other meaning refers to the limitations of what can be analyzed. Early in his career Freud put forth the idea that not everything was subject to interpretation and that we had to acknowledge the unknown element in the psychic material studied, even if clinical and theoretical efforts were intended to reduce the impenetrability: “The best-interpreted dreams often have a passage that has to be left in the dark, because we notice in the course of interpretation that a knot of dream-thoughts shows itself just there, refusing to be unraveled, but also making no further contribution to the dream-content.

This is the dream’s navel, and the place beneath which lies the Unknown” (1900a, chap. 7).

To this constraint on the “interpretative frenzy” (as Sándor Ferenczi described it) of some psychoanalysts was later added a discussion and evaluation of the limits of the effectiveness of psychoanalysis. In “Analysis Terminable and Interminable,” aside even from the limits imposed by the resistance of the id, the “viscosity of the libido,” or negative therapeutic reactions, Freud concluded, “We often have the impression, in the case of penis envy and masculine protest, of having opened a passage through the psychological strata to ‘bedrock,’ and to have thereby completed our work. Yet it cannot be otherwise, since for the psychic, the biological indeed plays the role of the underlying bedrock” (1937c).

ALAIN DE MIJOLLA

*See also:* Indications and contraindications of psychoanalysis; Initial interview(s); Preconscious, the; Transference neurosis; Transference relationship.

## Bibliography

Freud, Sigmund. (1900a). The interpretation of dreams. *SE*, 4–5.

———. (1937c). Analysis terminable and interminable. *SE*, 23: 216–253.

Kernberg, Otto. (1970). A psychoanalytic classification of character pathology. *Journal of the American Psychoanalytic Association*, 18 (4), 800–822.

Kohut, Heinz. (1971). *The analysis of the self*. New York: International Universities Press.

Zetzel, Elisabeth. (1968). The so-called good hysteric. *International Journal of Psycho-Analysis*, 49, 256–260.

## Further Reading

Stone, Leo. (1954). The widening scope of indications for psychoanalysis. *Journal of the American Psychoanalytic Association*, 2, 567–594.

Grand, Stanley. (1995). Classic revisited: Stone’s widening scope of indications for psychoanalysis. *Journal of the American Psychoanalytic Association*, 43, 741–764.

## ANDERSSON, OLA (1919–1990)

A Swedish psychologist and psychoanalyst, Ola Andersson was born on June 8, 1919, in Luleå, in

northern Sweden, where his paternal grandparents were landowners; he died in Stockholm on May 15, 1990. Andersson wrote two important works that have served as key references in the literature: his dissertation and an article in which he describes the historical and social context in which Freud's patient Emmy von N. lived.

In 1948 he began an analysis with René de Monchy, recently emigrated from the Netherlands. When Monchy left Sweden in 1952, Ola Andersson continued his psychoanalytic training with the Hungarian psychoanalyst Lajos Székely, who was then living in Stockholm, at a time when the Swedish Psychoanalytic Society was riven by internal conflicts. He devoted himself to research on the history of psychoanalysis and the translation of psychoanalytic texts. His first translation was a work by the English psychoanalyst Charles Berg, *Deep Analysis, the Clinical Study of an Individual Case*, which was followed by translations of Freud over a period of more than thirty years. He again devoted himself to translation when he contracted cancer at the end of the 1980s.

In December 1962, Andersson defended his doctoral dissertation, "Studies in the Prehistory of Psychoanalysis: The Etiology of Psychoneuroses and some Related Themes in Sigmund Freud's Scientific Writings and Letters, 1886-1896," at the University of Uppsala. The dissertation covered the period between Freud's return to Vienna after his stay in Paris and meeting with Jean Martin Charcot, and the first appearance of the word "psychoanalysis."

Andersson insists on the fact that he focused on studying the origins of Freudianism to avoid interpreting them in the light of future discoveries in psychoanalysis. He noted that he did not take into account biographical or psychological information about Freud. His dissertation was written from within the field of psychoanalysis and treats the evolution of psychoanalytic theory as continuous. He shows how Freud, in his attempt to explain clinical observation, formulated ideas that, for the most part, recalled the Herbartian *Vorstellungsmechanik*, a dynamic interaction of ideas. Freud himself never overtly acknowledged the influence of Johann Friedrich Herbart. Before Ola Andersson, researchers like Louise von Karpinska (1914), Maria Dorer (1932), and Ernest Jones (1953) had pointed out the similarities between Herbart's psychology and psychoanalysis, but he was the first to show that Herbart's ideas served as the

dominant psychological tendency in the academic milieu in which Freud worked when he was developing his theory. This dissertation is one of the first attempts to analyze the historical sources of Freud's theories and the circumstances surrounding the birth of psychoanalysis.

In 1960 Andersson was asked by the Sigmund Freud Archives in New York to investigate the case of Emmy von N. and locate any new biographical information about her. The results of his research appeared in an article that was presented in a talk given to the International Psychoanalytic Congress in Amsterdam in 1965, but was not published until 1979 in the *Scandinavian Psychoanalytical Review* (1979, 2, 5). In the article Andersson refers to the existing biographies of those close to Freud's patients, as well as to interviews with his children and family members, and personal documents. Because of the belated publication of the article, the historian Karl Schib was able to reveal the name of Emmy von N. for the first time in 1970. She was Fanny Moser, the widow of a successful manufacturer from Schaffhausen, Switzerland.

Andersson trained with the Swedish Psychoanalytic Society (Svenska Psykoanalytiska Förening), but his professional life was for the most part conducted outside the organization. He was never responsible for training other analysts, even though he was one of the rare Swedish psychoanalysts to have conducted original research, and his clinical activity appears to have been limited. During a period when society was concentrating its efforts on the clinical training of psychoanalysts, Andersson was the only one in Sweden involved in historical research on the origins of psychoanalysis.

Throughout his life he remained in close contact with the university, although he played no official role in the academic training of researchers. His interest later turned to matters of philosophy, psychology, and religion as they related to psychoanalysis. Between 1947 and 1980 he worked in a religious institution, the Stora Sköndal, as a professor of literature, then of psychology. He participated in the activities of another Swedish psychotherapeutic institution with a strongly Protestant tradition.

In an article published in 1990 in English by a member of the Swedish Psychoanalytic Society on the history of psychoanalysis in Sweden, Andersson was not mentioned. Nor is he listed in the Swedish Encyclopedia (1989-1996). His son no longer uses his name

and there is no tombstone to mark the place where he was buried. His obituary, which appeared on May 20, 1990, in the largest daily in the region, the *Dagens Nyheter*, was written by a Swedish psychoanalyst influenced by the Christian psychotherapeutic tradition that impregnated Swedish thought throughout the entire twentieth century.

PER MAGNUS JOHANSSON

See also: Ellenberger, Henri Frédéric; Emmy von N., case of; Moser-von Sulzer-Wart, Fanny Louise; Sweden.

### Bibliography

Andersson, Ola. (1962). *Studies in the prehistory of psychoanalysis*. Stockholm: Svenska Bokförlaget.

———. A supplement to Freud's case history of "Frau Emmy von N.", in "Studies on hysteria, 1895". *Scandinavian Psychoanalytic Review*, 2 (5).

Dorer, Maria. (1932). *Historische Grundlagen der Psychoanalyse*. Leipzig: Meiner.

Johansson, Per M. (1999). *Freuds Psykoanalys, Arvtagare i Sverige*. Göteborg: Daidalos.

Jones, Ernest. (1953–57). *Sigmund Freud. Life and work*. London: Hogarth.

## ANDREAS-SALOMÉ, LOUISE (LOU) (1861–1937)

A Russian writer and essayist, Louise Andreas-Salomé was one of the first practicing psychoanalysts. She was born on February 12, 1861, in St. Petersburg, Russia and died February 5, 1937, in Göttingen, Germany. Louise's father, Gustav von Salomé (57 years old at the time of her birth), of German-French origin, was a general in the service of the tsar. Her mother, Luise Wilm (38 years old at the time of Louise's birth), was from a family of Protestant merchants from Hamburg. Louise, the youngest of four children (she had three older brothers) was raised under feudal family conditions and turned out to be a very willful child. She took refuge in an imaginary world peopled with its own god and threw off the constraints imposed by her family. She refused confirmation and, at the time of her father's death in 1879, turned her back on religion. She shared her existential concerns with her first spiritual teacher, Hendrik Gillot (1836–1916), a fascinating preacher in the Dutch community. It was Gillot who

gave Louise the diminutive "Lou." Together they read authors like Baruch Spinoza, whose philosophy helped structure her research in psychoanalysis. However, Gillot's proposal of marriage destroyed their relationship. Her break with Gillot was unequivocal. Lou von Salomé left for Zurich in 1880, where she studied philosophy, history, art, and theology. She outlined her approach to God in her *Essays*.

When she was 21 she met the philosophers Paul Rée and Friedrich Nietzsche in Rome, at the salon of Malwida von Meysenbug. They wanted to formalize their reciprocal fascination in a working and living community. She replied to Gillot's exhortations, "I am certainly going to shape my own life the way I see it, come what may. . . ." This belief led her to take up psychoanalysis at the age of fifty, after an extremely turbulent life.

Lou Andreas-Salomé's first foray into psychoanalysis was the *Neue Quellen*; she found new answers to old questions in her own life, which she had approached especially through literature, for there are a number of autobiographical traces in her writings. Shortly after participating in the 1911 International Psychoanalytic Congress in Weimar, she went to Vienna to become a student of Freud's. In her journal, *In der Schule bei Freud* (1912–1913), keen observations of social life and critical opinions and personal hypotheses on psychoanalysis appeared side by side. Aside from Freud she was very impressed by Sándor Ferenczi and Viktor Tausk. It was through Tausk that she was able to make her first practical observations at the clinic for nervous disorders in Vienna.

After Vienna, Lou Andreas-Salomé continued to write to Freud on a regular basis and appears to have accepted only Freud as the supervisor of her own cures. After her visit with Freud's family in 1912, she became close with Anna Freud, the focal points of their relationship being Freud the psychoanalyst and Freud the man. They worked together on a subject of common interest, the *Tagtraum-Traumdichtung* (daydream-dream poem). Anna Freud's presentation to the Vienna Psychoanalytic Society for her admission to membership at the society, entitled "Schlagenphantasie und Tagtraum" ("Beating Fantasies and Daydreams"; 1922), was the result of their efforts together and also contributed to Andreas-Salomé's admission to the society. She died on February 5, 1937, in her home in Göttingen, Loufried, where she had lived since 1903 with the Oriental scholar Friedrich Carl Andreas.

Psychoanalysis marked a turning point in the life of Andreas-Salomé, who was immersed in contemporary philosophy, the philosophy of Spinoza, and deeply affected by the theory of the psychoanalytic unconscious and the libido theory. She devoted herself to the insoluble conflict of body and soul, the soma and the psyche, sexuality and the ego, masculine and feminine—subjects that appeared in all her psychoanalytic writing between 1911 and 1931. Her style, as exemplified in *Narzissmus als Doppelrichtung* (1921), was individualistic—capricious, expressive, and poetic. With her representation of a narcissism that was “happy to develop” as a “companion of life that renews being,” she completed her work on primary narcissism as a developmental phase and narcissism as a pathological form of self-love. She emphasized the concept of “double direction” that was present in Freud’s concept of the libido but which he had not developed further. The libido is in the service of the ego instinct and the “beyond-ego” (the death instinct). In this sense she was ahead of her time. *Zum Typus Weib* (On the Feminine Type; 1914) regroups her most important ideas on femininity and psychoanalysis. She introduced the feminine point of view into psychoanalytic discourse and focused her interest on the difference between the sexes, a difference that must be considered beyond individual differences. She emphasized the complementarity of relationships. For Andreas-Salomé an androgynous image signified a loss rather than a gain for both sexes. In her essay on femininity she introduced a utopia of feminine culture.

INGE WEBER

See also: Bjerre, Poul; Germany; Narcissism; Tausk, Viktor.

### Bibliography

- Andreas-Salome, Louise. (1964). *The Freud journal of Lou Andreas-Salome* (Stanley Leavy, Trans.). New York: Basic Books. (Original work published 1958)
- . (1990), *Das “zweideutige” Lächeln der Erotik. Texte zur Psychoanalyse*. Freiburg, Germany: Kore.
- . (1983). *Open letter to Freud*. Paris: Lieu Commun.
- . (1991). *Looking back: memoirs* (Ernst Pfeffer, Ed.; Breon Mitchell, Trans.). Memoirs, New York: Paragon House. (Original work published 1951)
- Freud, Sigmund, and Andreas-Salomé, Lou. (1972). *Sigmund Freud and Lou Andreas-Salomé: letters* (Ernst

Pfeffer, Ed.; William and Elaine Robson-Scott, Trans.). London: Hogarth Press and the Institute of Psycho-Analysis. (Original work published 1966)

Welsch, Ursula, and Wiesner, Michaela. (1988). *Lou Andreas-Salomé. Vom Lebensurgrund zur Psychoanalyse*. München-Wien-Leipzig: Internationaler psychoanalytischer Verlag.

## ANIMAL MAGNETISM

“Animal magnetism” is a term popularized by the Viennese doctor Franz Mesmer. In *Mémoire sur la découverte du magnétisme animal* (Propositions concerning animal magnetism; 1779) he defined it as the “property of the animal body that makes it susceptible to the influence of celestial bodies and the reciprocal action of those around it, made manifest by its analogy with the magnet.” He believed that a cosmic fluid attracted animate beings to one another. He considered poor receptivity to the fluid to be pathogenic, and the cure consisted in transmission of the fluid.

In Paris, Mesmer enjoyed enormous success. Faced with a crush of clients, he installed a “tub,” a round device around which patients sat in a group, and that was designed to concentrate and redistribute the fluid, resulting in beneficial convulsions. Mesmerism claimed to be a scientific discovery as well as a secret associated with initiation into a group of adepts.

In 1784 two committees appointed by the Académies Royales des Sciences et de Médecine (Royal Academies of Science and Medicine) drafted a report for the king on Mesmer’s “discovery.” The astronomer Jean Sylvain Bailly, reporter of the first committee, concluded that the fluid likely did not exist, and he sketched out an explanation in terms of “imagination” and “imitation.” In a secret report, released after the French Revolution, he noted the sexual nature of the convulsions, which he compared to orgasm.

That same year Armand de Puységur, a disciple of Mesmer, discovered (or rediscovered) that one can provoke calm crises that resemble the natural somnambulism of certain sleepers. He referred to this as artificial or induced somnambulism. From this point onward, magnetized subjects were no longer “convulsives,” but “somnambulists,” as in Puységur’s model. The somnambulists appeared changed: they uttered prophecies, showed signs of split personalities, and, under the influence of the fluid, which was supposed

to be transmitted by the “passes” of the magnetizer, exhibited extraordinary signs of “lucidity.” Puységur and his followers developed a standard form of treatment that differed considerably from what was often suggested by medical authorities. The magnetized patient directed the treatment; the magnetizer questioned the patient and let her talk (almost all patients were female). It was assumed that in a somnambulistic state the person had self-healing capacities. Magnetism became a social and cultural phenomenon of considerable importance.

In 1813, in his public lectures, Abbé José Custodio de Faria claimed that there was no need of a fluid to induce sleep, since by a simple command, a state of “lucid sleep” could be brought about in a subject. In 1823 and 1826 the physician Alexandre Bertrand returned to Bailly’s work on imagination and imitation. He connected Mesmeric phenomena to a traditional psychology of ecstasy, currently understood as a trance. An opposition was thus established, before the term “hypnotism” became popular, between orthodox fluidic Mesmeric magnetism and a heterodox psychological movement represented in France by Faria, Bertrand, and Joseph Noizet.

In Mesmeric terminology, the “relationship” refers primarily to the relation between the magnetized patient and the magnetizer. The literature in the field mentioned the sexual aspect of the relationship only rarely and with reticence. Yet love between a magnetizer and a somnambulist did become a distinct theme in fiction. Animal magnetism even became a kind of platitude, if we are to believe the article “Magnetism” in Gustave Flaubert’s *Dictionary of Accepted Ideas*: “An agreeable subject of conversation that can also be used to ‘impress women.’”

JACQUELINE CARROY

*See also:* Hypnosis; Liebeault, Ambroise Auguste; Occultism; Salpêtrière, hospital; Suggestion.

### **Bibliography**

- Darnton, Robert. (1968). *Mesmerism and the end of the Enlightenment in France*. Cambridge, MA: Harvard University Press.
- Ellenberger, Henri F. (1970). *The discovery of the unconscious: the history and evolution of dynamic psychiatry*. New York: Basic Books.

Flaubert, Gustave. (1954). *Dictionary of accepted ideas* (Jacques Barzun, Trans.). Norfolk, CT: New Directions Books.

Mesmer, Anton (1779). *Mémoire sur la découverte du magnétisme animal*. Geneva: P.F. Didot le jeune.

Puységur, Armand Marie Jacques de Chastenet, marquis de. (1786). *Mémoires pour servir à l’histoire et à l’établissement du magnétisme animal*. London: s.n.

Rausky, Franklin. (1977). *Mesmer ou la révolution thérapeutique*. Paris: Payot.

Roussillon, René. (1992). *Du baquet de Mesmer au “baquet” de S. Freud*. Paris: Presses Universitaires de France.

---

## **ANIMISTIC THOUGHT**

Freud drew the concept of animism from anthropologists such as Herbert Spencer, James George Frazer, Andrew Lang, Edward Burnett Tyler, and Wilhelm Wundt, who used it to refer to the tendency, thought to belong to people in primitive cultures and children, of attributing a soul to things and thus ascribing an intentionality to phenomena that would otherwise be understood in mechanistic causal terms. In psychoanalysis, the concept of animism is inextricably connected with projective mechanisms.

The connection between animistic thought and the mechanism of projection appears in 1912 in relation to some details concerning the relation between taboo and danger. This is a psychic danger because in the consistently applied animistic view of the universe of a person in a primitive culture, “every danger springs from the hostile intention of some being with a soul like himself, and this is as much the case with dangers which threaten him from some natural force as it is from other human beings or animals” (Freud, 1918 [1917], p. 200). Freud continued: “But on the other hand he is accustomed to project his own internal impulses of hostility on to the external world” (p. 200).

The concept of animism is further developed in *Totem and Taboo* (1912–1913a), in which it is related to magic and the omnipotence of thoughts. Here Freud attributes a world-view to animism, as an intellectual system, in which it is conceived as a vast whole that starts from a specific point. This first conception of the universe held by humanity is a mythological conception that gives way first to the religious and then to the scientific world-view. Its particular interest for psychoanalysis lies in its psychological aspect,



which is associated with the representation of souls that populate the universe and which, being separable from their original material ties, can be transposed into others. This led Freud on to the common ground that gave rise to superstition, as well as the belief in the existence of unconscious determinations or the negation of chance at an individual psychic level. Far from shying away from this kind of connection, Freud used it in 1915 as the basis for his justification of the hypothesis of the unconscious by recalling that consciousness can only ever be attributed to another person by analogy, just as animism confers a similar consciousness to that of the human being on things, plants or animals. This process of inference, which Freud designates here by the concept of identification, also justifies, with reference to the subject himself, making “the assumption of another, second consciousness which is united in one’s self with the consciousness one knows” (1915e, p. 170). The need to go beyond animism in order to be able to believe in the role of chance in external events—that is, in order not to succumb to superstition—recurs on several occasions in Freud’s work (1933a [1932]), particularly in relation to the inability to conceive of death as anything other than the result of a murder, whether this is through incompetence or negligence in the case of a doctor (Mijolla-Mellor, 1995).

The concept of animism seems to be inextricably linked with Freud’s philosophical reflection on the different forms of world-view *Weltanschauung* in particular the religious form that animism precedes and from which it differs, particularly through its connection with magic based on the belief in the omnipotence of thoughts, a belief that is also found in obsessional neurosis.

Finally, Freud found in animism a foundation not only for suggestion as a therapeutic technique but for the form in which it persists in the conduct of the analytic treatment. In this case it concerns a form of animism without a magical act, which is entirely based on “the overevaluation of the magic of words and the belief that the real events in the world take the course which our thinking seeks to impose on them” (1933a [1932], p. 166).

SOPHIE DE MIJOLLA-MELLOR

*See also:* Certainty; Omnipotence of thought; Primitive; Projection; Thought; *Totem and Taboo*.

### **Bibliography**

- Freud, Sigmund. (1912d). On the universal tendency to debasement in the sphere of love. *SE*, 11: 177–190.
- (1912–13a). Totem and taboo. *SE*, 13: 1–161.
- (1915e). The unconscious. *SE*, 14: 159–204.
- (1918 [1917]). The taboo of virginity (Contributions to the psychology of love III). *SE*, 11: 191–208.
- (1933a [1932]). New introductory lectures on psychoanalysis. *SE*, 22: 1–182.
- Mijolla-Mellor, Sophie de. (1995). *Meurtre familial. Approche psychanalytique d’Agatha Christie*. Paris: Dunod.

### **Further Reading**

- Roheim, Geza. (1930). *Animism, magic, and the divine king*. London: Kegan Paul, Trench, Trubner.

---

## **ANIMUS-ANIMA (ANALYTICAL PSYCHOLOGY)**

Anima and animus are gender specific archetypal structures in the collective unconscious that are compensatory to conscious gender identity. Thus, animus images primarily depict the unconscious masculine in a woman, and anima images primarily depict the unconscious feminine in a man.

The notion first appears in print in Carl Gustav Jung’s *Psychological Types*, in 1921.

One of the most complex and least understood features of his theory, the idea of a contrasexual archetype, developed out of Jung’s desire to conceptualize the important complementary poles in human psychological functioning. From his experiences of the emotional power of projection in his patients and in himself, he conceived first of the anima as a numinous figure in a man’s unconscious. Originally, Jung associated anima with mother and animus with father, but he soon began to identify their roots and effects in a broader spectrum. By 1925 he considered these concepts the two most comprehensive foundation stones of the psyche. Anima and animus, Jung says, are inborn as “virtual images” that acquire form “in the encounter with empirical facts which touch the unconscious aptitude and quicken it to life” (Jung, 1928, p. 300). The initial contrasexual content is introjected from the infant’s relationship with the parental figures.

Developmentally, then, separation from parental figures as primary objects is followed by the idealizing identification of anima and animus with figures in the environment, usually, but not necessarily, persons of the opposite sex. Subsequently, projections can be withdrawn from their objects and the apperception of anima/animus as intrapsychic objects made conscious. At that point anima and animus can act as the ego's interface to the collective unconscious. In most clinical instances, anima and animus figures personify the struggle between the culture-bound, collective images of masculine and feminine and the developmental urge to liberate one's individuality from collective norms.

The concept includes the potential in women and men to develop both masculine and feminine elements in themselves. The contrasexual archetypes fuel the Oedipal predicament. Differentiation between the parental imagoes and anima and animus projections leads out of the Oedipal fixation. A narcissistic identification with the contrasexual figure may result in positive or negative inflation or, alternatively, deteriorate into a state of flooding of the ego by unconscious contents.

Critics fault Jung for his confusion of outer life realities of women and men and the inner world of anima and animus images; for example, his repeated assignment of relatedness (Eros) both to anima and to women, and rationality (Logos) both to animus and to men. This confusion can lead to the false equation of culturally acquired elements with inborn male and female characteristics.

BETTY DE SHONG MEADOR

*See also:* Collective unconscious (analytical psychology); Projection and "participation mystique" (analytical psychology); Analytical psychology.

### **Bibliography**

- Jung, Carl Gustav. (1921). Psychological types. *Coll. Works* (Vol. VI). London: Routledge & Kegan Paul.
- (1928a [1935]). The relations between the ego and the unconscious. *Coll. Works* (Vol. VII). London: Routledge & Kegan Paul.
- (1928b [1948]). On psychic energy. *Coll. Works* (Vol. VIII). London: Routledge & Kegan Paul.
- (1928c [1948]). General aspects of dream psychology. *Coll. Works* (Vol. VIII). London: Routledge & Kegan Paul.

——— (1928d [1948]). Instinct and the unconscious. *Coll. Works* (Vol. VIII). London: Routledge & Kegan Paul.

——— (1951). Aion: Researches into the phenomenology of the self. *Coll. Works* (Vol. IX). London: Routledge & Kegan Paul.

Samuels, Andrew. (1985). *Jung and the Post-Jungians*. London-Boston: Routledge.

Tresan, David. (1992). The anima of the analyst. Its development, gender, and soul. In *Psychotherapy* (pp. 73–110). Wilmette, IL: Chiron Publications.

---

**ANLEHNUNG.** *See* Anaclitic

---

**ANNA-FREUD CENTER.** *See* Hampstead Clinic

---

### **ANNA O., CASE OF**

Anna O. was the first case described by Joseph Breuer in his *Studies on Hysteria* (1895d). Her real name, Bertha Pappenheim, was revealed by Ernest Jones in his 1953 biography of Freud, shocking his contemporaries. When Breuer saw her for the first time toward the end of November 1880, Bertha Pappenheim, a friend of Martha Bernays (Freud's future wife), was about 22 years old. Her problems had been triggered when her father, whom she loved deeply, fell seriously ill. Her symptom was a "nervous cough," which Breuer quickly diagnosed as being of hysterical origin. She soon suffered from other symptoms as well: squinting, partial paralysis, visual disturbances, and a lack of feeling in her right arm. She also exhibited alternating states of consciousness, which drew Breuer's attention as a sign of a self-hypnotic condition that he would gradually use for therapeutic purposes.

These symptoms were followed by speech disturbances (she could only speak English, then became mute), which led Breuer to conclude that she was hiding something and must be made to speak. This therapeutic insight was followed by an improvement in her condition, but the death of her father in April 1881 caused a relapse. It was at this time that she began recounting lengthy stories in a highly dramatic

tone of voice during her self-induced hypnotic states in the evening. These were accompanied by violent affects that highlighted their significance. She referred to this initial “catharsis” as the *talking cure* and sometimes as *chimney sweeping*.

It was most likely during the summer of 1881, probably in mid-August (although Henri Frédéric Ellenberger says it occurred during the first months of 1882), that an incident occurred that was to have profound significance on the future of Breuer’s method. Anna refused to drink liquids, but in her hypnotic state revealed that she had been disgusted to discover her lady companion’s dog drinking out of her glass. When awakened she asked for a glass of water. The etiological function of the “cathartic method” was born and Breuer had her identify, for each of her symptoms, the memory of the “primitive scene” from which they originated but which had apparently been forgotten.

Between December 1881 and June 1882, a new symptom appeared, which led to a renewal of what she had experienced a year earlier, as indicated by Breuer’s notes at the time. This “talking out” (1895d, p. 36), as Breuer referred to it, was not simple, however: “The work of remembering was not always an easy matter and sometimes the patient had to make great efforts. On one occasion our whole progress was obstructed for some time because a recollection refused to emerge” (p. 37). Freud was later to draw significant conclusions about this “resistance” on the part of the patient.

In 1882, however, Breuer had little understanding of “transference,” and this continued as late as 1895, when he completed his description of this intelligent, intuitive, and kind woman: “The element of sexuality was astonishingly undeveloped in her. The patient, whose life became known to me to an extent to which one person’s life is seldom known to another, had never been in love; and in all the enormous number of hallucinations which occurred during her illness that element of mental life never emerged” (1895d, p. 21–22).

In the wake of Breuer’s colorless narrative, a number of mysteries and legends have grown up around the circumstances of the rupture of such a strong affective relationship. In fact, Breuer was apparently called to her bedside the very evening they said goodbye to one another after the conclusion of the treatment. She was in the midst of a hysterical crisis

and pretended to be giving birth “to Doctor Breuer’s child.” Ernest Jones writes that Breuer was “fled the house in a cold sweat. The next day he and his wife left for Venice to spend a second honeymoon, which resulted in the conception of a daughter; the girl born in these curious circumstances was nearly sixty years later to commit suicide in New York” (Jones, 1953, Vol. 1, p. 148).

In fact, historical research has shown that this story is false. Anna O. was hospitalized in the clinic of Kreuzlingen in July 1882 at Breuer’s request. She was suffering from neuralgic pains of the trigeminal nerve, which had led Breuer to administer increasingly strong doses of morphine, from which she eventually had to be weaned. We know that Bertha Pappenheim, even though Breuer was no longer her physician, was gradually healed and devoted her life and her writing after 1895 to helping young Jewish girls, single mothers, and orphans. She was one of the first “social workers” and her work earned her the admiration of everyone who knew her until her death on May 28, 1936.

As for Breuer, that summer he and his wife he did not escape to Venice but spent their vacation in Gmunden, near the Traunsee in Austria. Their daughter Dora was born on March 11, 1882, three months before the end of Anna O.’s treatment. But such legends die hard and the detractors of Freud and psychoanalysis continue to make use of them.

Breuer continued to care for “nervous” patients and described his method of treatment to his young protégé Freud on November 18, 1882, and again in July 1883. This was the point of departure for the etiological research that Freud, somewhat disillusioned by Jean Martin Charcot’s lack of interest in the story, was unable to begin until nearly ten years later.

In his “On the History of the Psycho-analytic Movement” (1914d), Freud, who always reported that the origins of psychoanalysis lay in “J. Breuer’s cathartic method,” (in 1910a, for example), spoke of the transference aspect that, until then, had been neglected: “Now I have strong reasons for suspecting that after all her symptoms had been relieved Breuer must have discovered from further indications the sexual motivation of this transference, but that the universal nature of this unexpected phenomenon escaped him, with the result that, as though confronted by an ‘untoward even,’ he broke off all further investigation” (1914d, 12).

On June 2, 1932, in a letter to Stefan Zweig, Freud gave further details about the end of Anna O.'s treatment while reminiscing about Breuer: "Asked what was wrong with her, she replied: 'Now Dr. B.'s child is coming!' At this moment he held in his hand the key that would have opened the 'doors to the Mothers,' but he let it drop. With all his great intellectual gifts there was nothing Faustian in his nature. Seized by conventional horror he took flight and abandoned the patient to a colleague."

The story of Anna O. has always been a source of contention. In 1895 it was published, primarily to demonstrate that the cathartic method, dating from 1881–1882, preceded the research published by Pierre Janet. In 1953 it was used by Jones to demonstrate Freud's courage and scientific creativity compared to Breuer's presumed cowardice. Following the research of Henri Frédéric Ellenberger and Albrecht Hirschmüller, the real history is better known, and while the romanticized presentation of therapy can no longer escape the notice of the psychoanalytic community, it still contains traces of Freud's later thinking. In any event, the distortions of writing do not justify believing, as the detractors of psychoanalysis such as Mikkel Borch-Jacobsen would have us do, that Breuer and Freud were charlatans and Bertha Pappenheim was simply a "fraud."

ALAIN DE MIJOLLA

See also: Breuer, Josef; Cathartic method; *Five Lectures on Psycho-Analysis*; *Studies on Hysteria*; Hypnoid states; Pappenheim, Bertha.

### Bibliography

- Edinger, Dora. (1963). *Bertha Pappenheim: Leben und Schriften*. Frankfurt: D. Edinger.
- Ellenberger, Henri F. (1970). *The discovery of the unconscious: The history and evolution of dynamic psychiatry*. New York: Basic Books.
- . (1972). "L'histoire d'Anna O.": Étude critique avec documents nouveaux. In *Médecines de l'âme*. Paris: Fayard, 1995. (Reprinted from *L'évolution psychiatrique*, 37 (4), 693–717.)
- Freud, Sigmund, and Breuer, Josef. (1895d). *Studies on hysteria*. SE, 2: 48–106.
- Freeman, Lucy. (1972). *The story of Anna O.* New York: Walker.

Hirschmüller, Albrecht. (1978). *Physiologie und Psychoanalyse in Leben und Werk Josef Breuers*. Bern-Stuttgart: Hans Huber.

Jones, Ernest. (1953–1957). *Sigmund Freud. Life and work*. London: Hogarth.

---

### ANNÉE PSYCHOLOGIQUE, L'

*L'Année psychologique* (AP) is the leading French review of scientific psychology. It was founded in 1894 by Henri Beaunis and Alfred Binet to publish the research activities conducted in the Sorbonne's psychology laboratory. Henri Beaunis was a physiologist and a representative of the School of Nancy. Alfred Binet was a psychologist and worked for seven years with Dr. Féré under Jean Martin Charcot (on animal magnetism, fetishism, and hysteria). He soon succeeded Beaunis as the head of the laboratory and the review.

The review went through three main periods: 1894–1911 (the date of Binet's death); 1912 to the end of the Second World War, when it was under the direction of Henri Piéron; and from the liberation of Paris until today, under the direction of Paul Fraise. It was only during the first period, under Binet's editorship, that psychoanalysis featured prominently in the review, at a time when references to the subject were practically nonexistent in France. The principal center of interest then shifted to experimental psychology. The review consists of three sections: original papers, comments and reviews, and bibliographies.

Alfred Binet, a friend of Édouard Claparède and J Languier des Bancelles, both Swiss, became interested in psychoanalysis early in his career through his relation to psychopathology and forensic psychology. But he didn't read German. In 1908, he commissioned Carl Gustav Jung to write an article on psychoanalysis, "L'analyse des rêves" (The analysis of dreams), which appeared in the 1909 issue of the AP. However, in a letter to Freud, Jung qualified the article as an "insignificant, superficial thing." In 1912 there appeared an article by Alphonse Maeder entitled "Sur le mouvement psychoanalytique" (On the psychoanalytic movement). This much longer article acknowledged the development of a Freudian school that had renewed psychiatry and psychoanalysis.

In the AP under Pieron's direction, after 1912, psychoanalysis played a minor role, and was relegated to reviews of publications by Freud and Jung, written by Pieron. The tone is generally critical. As for the young French psychoanalytic movement, it was ignored by the AP. Following the liberation, Paul Fraise replaced Henri Pieron as the editor-in-chief, reinforcing its experimental bias. After 1949 the term "psychoanalysis" simply disappeared from the bibliographic entries listed in the publication.

ANNICK OHAYON

*See also:* Maeder, Alphonse E.

### **Bibliography**

- Binet, Alfred, and Féré, Charles. (1887). *Animal magnetism*. New York, D. Appleton and Company.
- Jung, Carl G. (1909b). The analysis of dreams. *Coll. Works* (Vol. IV). London: Routledge & Kegan Paul.
- Maeder, Alphonse. (1912). Über die Funktion des Traumes (mit Berücksichtigung der Tagesträume, des Spieles, usw.). *Jahrbuch für psychoanalytische und psychopathologische Forschungen*, IV.
- Ohayon, Annick. (1994). Lectures de la psychanalyse dans *L'Année psychologique* de Piéron, 1913–1945. *Actes du XIIe Congrès annuel de Cheiron Europe*. p. 263–270.

## **ANNIHILATION ANXIETIES**

In annihilation anxieties, the basic danger involves a threat to psychic survival, experienced as a present menace or as an anticipation of an imminent catastrophe. The experience entails fantasies and/or feelings of helplessness in the face of inner and/or outer dangers against which the person feels he can take no protective or constructive action.

The construct derives from Freud's 1926 view of a traumatic situation where the person is faced with a quantity of stimulation that he/she cannot discharge or master, a failure of self-regulation. The experience of overwhelmed helplessness has much in common with Jones' aphanisis, Klein's psychotic anxiety, Schur's primary anxiety, Winnicott's unthinkable anxiety, Bion's nameless dread, Stern's biotrauma, Frosch's basic anxiety, Little's annihilation anxiety, and Kohut's disintegration anxiety. Derivatives of underlying annihilation anxieties are fears of being overwhelmed, destroyed, abandoned, mortified, mutilated, suffocated

or drowned, of intolerable feeling states, losing mental, physical or bodily control, of going insane, dissolving, being absorbed, invaded, or shattered, of exploding, melting, leaking out, evaporating or fading away.

Annihilation experiences and anxieties are universal in early childhood, where psychic dangers are regularly experienced as traumatic. Eight related ideational contents are seen to comprise the major dimensions of annihilation anxieties: fears of being overwhelmed, of merger, of disintegration, of impingement, of loss of needed support, of inability to cope, of concern over survival, and of responding with a catastrophic mentality. Pathological annihilation anxieties are a consequence and correlate of psychic trauma, ego weakness, object loss, and pathology of the self. They can be consequential for the process of psychoanalytic therapy and may influence resistance, transference, and countertransference in a given treatment. Symptoms, thought patterns, affect states, and behaviors are especially resistant to change when they are defending against such anxieties.

The concept is especially relevant to psychoses, borderline and narcissistic character pathology, psychic trauma, nightmares, anxiety states and phobias. Annihilation anxieties under various names are mentioned widely in the psychoanalytic literature, but there has been insufficient systematic exploration of interrelationships with psychic trauma, ego weakness and deficit, regression, hostility, depression, transference, and countertransference.

MARVIN HURVICH

*See also:* Anxiety.

### **Bibliography**

- Freud, Sigmund. (1926d [1925]). Inhibitions, symptoms and anxiety. *SE*: 20: 77–175.
- Hurvich, Marvin. (1989). Traumatic moment, basic dangers, and annihilation anxiety. *Psychoanalytic Psychology*, 6, 309–323.
- Little, Margaret. (1960). On basic unity. *International Journal of Psychoanalysis*, 41, 377–384.
- Stern, Max. (1951). Anxiety, trauma, and shock. *Psychoanalytic Quarterly*, 20, 179–203.
- Winnicott, Donald. (1974). The fear of breakdown. *International Review of Psychoanalysis*, 1, 103–107.

## ANOREXIA NERVOSA

The term “anorexia nervosa” was coined by William Gull in 1873. Although the term has existed for little more than a century, the clinical description of the syndrome is much older. Among other works, we can find a description in Avicenna in the eleventh century, and we have no difficulty recognizing it in Richard Morton’s 1694 account of “nervous consumption.” The first complete description in terms identical to those of Gull can be found in an article written by Dr. Louis Victor Marcé in 1860.

The classic clinical picture of anorexia brings together three factors: weight loss of more than 10 percent, amenorrhea, and the absence of a manifest melancholic or delusional mental disturbance. But the emphasis has changed from these classic symptoms to more specific symptoms, such as a confused body image, denial of being thin, desperate desire to be thin, and fear of putting on weight. Also, two major types of anorexia nervosa have been distinguished: purely restrictive forms and forms associated with bulimic episodes accompanied by weight monitoring, self-induced vomiting, and excessive use of laxatives and diuretics. Anorexia nervosa frequently occurs during adolescence, especially among females (ten girls for every one boy). It affects between 1 and 2 percent of the female adolescent population.

Without ever dealing specifically with eating disorders, Freud did in fact establish all of the perspectives—hysteria, melancholia, and “actual” neurosis—around which the pathological manifestations of anorexia can be understood metapsychologically. As a hysteria, anorexia involves a double polarity: oral fixations of the libido serve as a point of regression, and sexual fantasies become oral and are then repressed. As a melancholia, anorexia involves melancholy over the issue of object loss and a loss of instinctual needs. Freud speaks of an anesthesia that leads to melancholic thinking, which opens up a research path related to the next perspective. As an “actual” neurosis, anorexia poses a threefold question about the importance of the current situation, of somatic and infrarepresentational factors, and of the inadequacy of the ego and capacities for working matters out.

Melanie Klein and her students have stressed the importance of archaic fantasies of sadistic devouring, destruction, and poisoning in anorexia. Psychoanalysts dealing specifically with eating disorders initially considered them to be primarily a symptom and took

little interest in the organization of the personality. But because of the complexity of cases and the frequent severity of the evolution of the disorder, the pathology of the personality assumed a growing importance in their work. The Göttingen symposium, organized by J. E. Meyer and H. Feldmann (1965), recognized anorexia nervosa as having a specific structure and viewed it not so much as an attempt toward compromise formation but rather as an attempt to deal with psychotic failures in the organization of the ego by reestablishing the mother-child unit.

Evelyne Kestenberg et al. (1974) have provided a remarkable description of the specific modes of the regression and instinctual organization in anorexia. This organization is characterized by recourse to a primary erogenous masochism in which pleasure is linked directly to a refusal to satisfy a need. Pleasure does not accompany the feeling of having something inside oneself; rather, anorexia eroticizes not satisfying a vital need. Similarly, relationships become dominated by pleasure in their being not satisfied. The hedonization of refusal becomes the guardian of the feeling of being or existing in one’s own right, corporeal activity and the body being thus liberated from all external holds. The most complete form of this hedonization of refusal is “hunger orgasm.”

Different studies stress the importance of the dependence/autonomy conflict and the fundamental vulnerability of anorexics. This vulnerability is associated with powerful passive desires and, as a consequence, a constant fear of intrusion, particularly an invasion of the body by the object on which these desires depend. To pose the problem in terms that highlight the paradox of anorexia: anorexics destroy themselves to prove their own existence. The destructive effect is not sought after for its own sake, and in this respect anorexia is not a suicidal behavior, although it can be seen as the result of unleashing aggression and turning against the self an incorporation fantasy of an object experienced as destructive for the self. Anorexia is the consequence of using a physiological need indispensable for survival to preserve a feeling of autonomy. In doing so—and this is the second paradox—anorexics find themselves in fact more dependent on an environment from which they sought to free themselves. By making refusal the instrument of their liberation, they alienate themselves from the object of the refusal, which they can neither lose nor interiorize.

The anorexia-bulimia tandem leads to questions about whether a problem of dependence underlies other behaviors grouped under the label “addictive behaviors”: drug addiction, alcoholism, pathological gambling, and shopping, as well as abuse of psychotropic drugs and kleptomania. The fragile narcissistic bases of such addicts makes their object relations difficult to manage, because these object relations become too exciting and too dangerous. Addiction to products or behavioral practices offers addicts a need-satisfying relational substitute that is always accessible and which they believe they can control, while in fact they fall into its grip.

The eating disorder represents a substitute for the object whose loss could plunge these patients into a collapse. This attempt to find a substitute object in addictive behavior represents a perverse organization of a relationship to the object in which the object is not recognized as having its own desires and differences, but is acknowledged only for purposes of narcissistic reassurance. An analogy exists among these patients’ relationship with food, their relationship with their own bodies, and their object relations, as well as their modes of emotional investment in general.

Family-therapy approaches illustrate the sensitivity of these patients to the influences of their environment. These eating disorders can be seen as existing at an intersection between individual psychology, family interactions, the body in its most biological aspect, and society in general. An essentially mental disorder may thus have grave somatic consequences, and these consequences may in turn affect the anorexic’s psychic state and thus contribute to maintaining the disorder.

Addictive behaviors raise questions about the type of society in which we live, particularly with the increase in the frequency of these disorders accompanying the increase in consumerism in our societies.

PHILIPPE JEAMMET

*See also:* Adolescence; Autistic capsule/nucleus; Bulimia; *Flower Doll: Essays in Child Psychotherapy*; Kestenberg-Hassin, Evelyne.

### **Bibliography**

Agman, Gilles; Corcos, Maurice; and Jeammet, Philippe. (1994). Troubles des conduits alimentaires. In *Encyclopédie medico-chirurgicale (Psychiatrie vol., fasc. 37-350-A-10)*. Paris: Encyclopédie medico-chirurgicale.

Brusset, Bernard. (1998). *Psychopathologie de l'anorexie mentale*. Paris: Dunod.

Kestenberg, Evelyne; Kestenberg, Jean; and Decobert, Simone. (1972). *La faim et le corps: une étude psychanalytique de l'anorexie mentale*. Paris: Presses Universitaires de France.

Venisse, Jean-Luc (Ed.). (1991). *Les nouvelles addictions*. Paris: Masson.

### **Further Reading**

Aronson, Joyce K. (ed.) (1993). *Insights in the dynamic psychotherapy of anorexia and bulimia: An introduction to the literature*. Northvale, NJ: Jason Aronson.

Freedman, Norbert, et. al. (2002). Desymbolization: concept & observations on anorexia & bulimia. *Psychoanalysis and Contemporary Thought*, 25,165-200.

Sours, John. (1980). *Starving to death in a sea of objects: the anorexia nervosa syndrome*. New York: Jason Aronson.

Thoma, Helmut. (1967). *Anorexia nervosa*. New York: International Universities Press.

Wilson, Charles, Hogan, C., and Mintz, Ira. (1985). *Fear of being fat: the treatment of anorexia and bulimia (2nd ed)*. Northvale, NJ: Aronson.

Young-Bruehl, Elisabeth. (1993). Feminism and psychoanalysis: in the case of anorexia nervosa. *Psychoanalytical Psychology*, 10, 317-330.

---

## **ANTHROPOLOGY AND PSYCHOANALYSIS**

Anthropology, a term common to the European languages, has several meanings, ranging from the theological—the expression of divine things in human terms—to the modern—the study of humanity as a unit, including an examination of its biological, psychic, and social nature, as well as mankind’s historical and prehistorical development. During Freud’s lifetime, the term acquired new connotations through the expansion of anthropological research, by both Anglo-American and European researchers.

The word “anthropology” was not part of Freud’s vocabulary any more than “sociology,” which Freud integrated (*Sozial-, oder Massenpsychologie*) with psychoanalysis. His avoidance of the terms is significant. In the case of anthropology he used the German *Geisteswissenschaften*, literally the “sciences of mind,” and enumerated the domains in which psychoanalysis was pertinent: the explanation of the “major cultural

institutions,” exogamy, the construction of the state, law, the social order, art, morality and moral awareness, religion. He also refers to research on myths, tales, and legends, cultural history and development, linguistics and ethnology, the history of the development of the human species—in fact, the principal subjects of anthropology.

Freud’s justification of the relevance of psychoanalysis to these fields was systematized after the publication of *Totem and Taboo* (1912–13a). In “The Claims of Psycho-analysis to Scientific Interest” (1913j), there is a lengthy explanation of this, an idea that was further developed by Freud in his later writings (1914d, 1923a, 1924f, 1925d, 1926e, 1933a). Initially a medical specialization concerned with neurotic symptoms, the status of psychoanalysis changed with the publication of *The Interpretation of Dreams* (1900a). “The analysis of dreams gave us an insight into the unconscious processes of the mind and showed us that the mechanisms which produce pathological symptoms are also operative in the normal mind. Thus psychoanalysis became a depth-psychology and capable as such of being applied to the mental sciences” (1923a, p. 253). Moreover, psychoanalysis, which is the science of the genesis of psychic formations, is the basis for all psychology, “since nothing that men make or do is understandable without the co-operation of psychology, the applications of psychoanalysis to numerous fields of knowledge, in particular to those of the mental sciences, came about of their own accord” (1933a, p. 145).

In 1907 Freud found a resemblance between *compulsive activities and religious practices* (1907b) and compared the phenomenology of rituals with a shared etiology of conflict. In 1913 he postulated the identity of the “dynamic source” that generated “the psychic behavior of isolated individuals and societies” (1913j). In *Group Psychology and the Analysis of the Ego* (1921c) and later in *Civilization and Its Discontents* (1930a [1929]), Freud showed how the instinctual dynamic of groups is the same as that of individuals, and excluded any “herd instinct.” This identity enabled psychoanalysis to be applied to (or implied in) the explanation of cultural formations and allowed researchers to exploit the profound analogy between individual psychic formations and cultural formations.

The fundamental analogy is that of the “two wishes which combine to form the Oedipus complex coincide precisely with the two principal prohibitions imposed

by totemism (not to kill the tribal ancestor and not to marry any woman belonging to one’s clan)” (1923a, p. 253). Here Freud’s research makes a direct reference to anthropology.

All the central concepts of psychoanalysis are related to anthropology and to group psychology because of their intrinsic relation to individual psychology, the family being the intermediate term. Aside from the Oedipus complex and ritual, the ego, ego ideal, and superego are derived from this, as are identification and defensive formations, which are associated with education and culture, especially inhibition and sublimation.

The study of myth, religion, and society extended Freud’s work, primarily through the writings of Otto Rank, Theodor Reik, and Géza Róheim. Later, American cultural anthropology made use of the psychoanalytic point of view, although in diluted form. As anthropology evolved and became more interdisciplinary, psychoanalysis became one of its key referents. In France, authors such Georges Devereux, Roger Bastide, and Bernard Juillerat are examples of this interrelation. In *Tristes Tropiques* (1955), Claude Lévi-Strauss insisted on the decisive role played by the discovery of Freud’s theories in his training as an ethnologist.

According to Freud, psychoanalysis discovered universal psychic processes; moreover, it possesses explanatory and not purely descriptive capability. Critics of the relevance of psychoanalysis for anthropology have attacked both aspects of its explanatory powers. In fact the articulation of knowledge through field studies is as complicated as it is in the case of metapsychology and therapeutic methods. However, Freud provided us with a way to move forward in *Moses and Monotheism* (1939a [1934–38]), his masterful analysis of Jewish and Christian monotheistic cultures.

MICHÈLE PORTE

*See also:* *Basic Problems of Ethnopsychiatry*; *Civilization (Kultur)*; *Collective psychology*; Devereux, Georges (born György Dobo); *Ethnopsychanalysis*; Malinowski, Bronislaw Kaspar; Mead, Margaret; *Mythology and psychoanalysis*; *Phylogenesis*; *Primitive*; *Psychoanalysis of Fire, The*; *Racism, anti-Semitism, and psychoanalysis*; Róheim, Géza; *Sociology and psychoanalysis*, *sociopsychanalysis*; *Taboo*; *Totem and Taboo*; *Transcultural*.



### Bibliography

- Bertrand, Michèle, and Doray, Bernard. (1989). *Psychanalyse et Sciences sociales*. Paris: La Découverte.
- Freud, Sigmund. (1923a). The libido theory. *SE*, 18: 255–259.
- . (1933a [1932]). *New introductory lectures on psycho-analysis*. *SE*, 22: 1–182.
- . (1939a [1934–38]). *Moses and monotheism*. *SE*, 23: 7–137.
- Muensterberger, Werner. (1970). *Man and his culture: psychoanalytic anthropology after "Totem and Taboo."* New York: Taplinger.

### Further Reading

- Devereux, George. (1952). Psychiatry and anthropology: some research objectives. *Bulletin of the Menninger Clinic*, 16, 167–177.
- Kardiner, Abraham. (1961). Psychoanalysis and anthropology. *Science and Psychoanalysis*, 4, 21–27.
- LaBarre, Weston. (1961). Psychoanalysis in anthropology. *Science and Psychoanalysis*, 4, 10–20.
- Muensterberger, Warren. (Ed.). (1969). *Man and his culture: psychoanalytic anthropology after "Totem and Taboo."* London: Rapp & Whiting.
- Roheim, Geza. (1950). *Psychoanalysis and anthropology*. New York: International Universities Press.
- Wallace, E. (1983). *Freud and anthropology: a history and reappraisal*. *Psychological Issues. Monograph 55*. New York: International Universities Press.

## ANTICATHEXIS

Counter-investment—translated as anticathexis in the *Standard Edition*—is a particular mode of investment used by the ego for defensive purposes. The term is used to designate the dynamic defensive role of certain cathexes and to take into account the economic dimension of repression.

The term first appeared in *The Interpretation of Dreams*: “There then follows a defensive struggle—for the *Pcs.* in turn reinforces its opposition to the repressed thoughts (i.e., produces an ‘anticathexis’)” (1900a, p. 605). The counter-cathexed elements are the “repressed thoughts” mentioned in the letter to

William Fliess of February 19, 1899. Thus Freud’s conception of repression includes the idea that a counter-position, an investment against, must be set up to keep the undesirable idea in the unconscious. The material that is cathected in order to support repression may consist of an idea linked to the repressed idea, which has thus remained relatively easily accessible to the association of ideas, or it may consist of more remote mental or motor elements. The latter case involves “reaction formations” such as those observed in the character neuroses.

The mental energy deployed in the anticathexis is libido that has been reclaimed by a withdrawal of cathexis from other psychic formations; the pleasure that the realization of a repressed desire might provide is rendered impossible, but the preservation of equilibrium between forces limits the quantity of free energy and implies a form of pleasure that favors the maintenance of the defensive system. Meanwhile, the restrictions on the libido that are involved in anticathexis have a mental cost since they restrict the subject’s thoughts or activities.

Gradually, Freud granted the role of organizing counter-cathexes to the ego: “[When] certain ideas . . . [are] cut off from consciousness, we must, on the psycho-analytic view, assume that these ideas have come into opposition to other, more powerful ones, for which we use the collective concept of the ‘ego’” (1910i, p. 213). He also pointed out the role of “setting up an ideal” as one of the ego’s conditions for repression (1914c).

The theory of anticathexis was taken up again in Freud’s metapsychology and in *Inhibitions, Symptoms, and Anxiety* (1926d [1925]). There he emphasized that the constant pressure of the drives necessitated a continuous counter-pressure. In “The Unconscious” (1915e), he assigned to anticathexis not only the role of maintaining this counter-pressure, but also the task of organizing the permanent point of reference that is the prerequisite of all repression (i.e., “primal repression”): “Anticathexis is the sole mechanism of primal repression. . . . It is very possible that it is precisely the cathexis which is withdrawn from the idea that is used for anticathexis” (1915e, p. 181).

PAUL DENIS

See also: Cathexis; Defense mechanisms; Desexualization; Economic point of view, the; Narcissistic defenses;

Primal repression; Psychic energy; Reaction-formation; Repression.

### **Bibliography**

- Freud, Sigmund. (1900a). The interpretation of dreams. *SE*: 4–5.
- . (1910i). The psycho-analytic view of psychogenic disturbance of vision. *SE*: 11: 209–218.
- . (1915e). The unconscious. *SE*: 14: 159–204.
- . (1926d [1925]). Inhibitions, symptoms and anxiety. *SE*: 20: 75–172.
- Rouart, Julien. (1967). Les notions d'investissement et de contre-investissement à travers l'évolution des idées freudiennes. *Revue française de psychanalyse*, 31 (2), 193–213.

## **ANTICIPATORY IDEAS**

The term *Erwartungsvorstellungen* is generally translated as “anticipatory ideas,” although this term does not reflect “*Erwartung*”’s connotations of waiting, expectancy, or hope. It refers to the hypotheses that the analyst communicates to the patient to incite him or her to pursue in greater depth the interpretation of unconscious content; in this sense, the term is sometimes accompanied by the qualifying adjective *conscious*.

In 1901, in his analysis of the dream-work, Freud invoked this notion when he proposed that secondary revision operates upon the contents of a dream just as it does upon any other content, by apprehending it via anticipatory ideas. But in 1909, this idea assumed its proper place in interpretive analytic work and refuted the accusation of *suggestion* that was beginning to be made about the method. In “Analysis of a Phobia in a Five-Year-Old Boy,” Freud wrote: “In a psycho-analysis the physician always gives his patient (sometimes to a greater and sometimes to a lesser extent) the conscious anticipatory ideas by the help of which he is put in a position to recognize and to grasp the unconscious material. For there are some patients who need more of such assistance and some who need less; but there are none who get through without some of it” (1909b, p. 104).

The following year, in “The Future Prospects of Psycho-Analytic Therapy,” Freud further explained: “The mechanism of our assistance is easy to understand: we give the patient the conscious anticipatory idea [the idea of what he may expect to find] and he

then finds the repressed unconscious idea in himself on the basis of its similarity to the anticipatory one. This is the intellectual help which makes it easier for him to overcome the resistances between conscious and unconscious” (1910d, pp. 141–142). In “The Dynamics of Transference,” Freud emphasized the hope that characterizes anticipation or waiting: “If someone’s need for love is not entirely satisfied by reality, he is bound to approach every new person whom he meets with libidinal anticipatory ideas... th[e] transference has precisely been set up not only by the *conscious* anticipatory ideas but also by those that have been held back or are unconscious” (1912b, p. 100).

Freud’s last mention of this notion is found in two passages of his *Introductory Lectures on Psycho-Analysis* (1916–1917a [1915–1917]). First, in the lecture “Transference,” where he emphasized the participation of intelligence in the process of becoming aware, Freud wrote: “There is no doubt that it is easier for the patient’s intelligence to recognize the resistance and to find the translation corresponding to what is repressed if we have previously given him the appropriate anticipatory ideas. If I say to you: ‘Look up at the sky! There’s a balloon there!’ you will discover it much more easily than if I simply tell you to look up. . . . In the same way, a student who is looking through a microscope for the first time is instructed by his teacher as to what he will see; otherwise he does not see it at all, though it is there and visible” (p. 437). Thus, the mechanism of suggestion is clearly involved in guiding patients. However, in the next lecture, “Analytic Therapy,” Freud emphasized the difference between this technique and suggestion: “After all, his conflicts will only be successfully solved and his resistances overcome if the anticipatory ideas he is given tally with what is real in him. Whatever in the doctor’s conjectures is inaccurate drops out in the course of the analysis; it has to be withdrawn and replaced by something more correct” (p. 452).

The necessity for anticipatory ideas to be appropriate to the patient’s reality was underscored by Ferenczi in his paper “On Forced Phantasies” (1924): “When we interpret the patient’s free associations, and that we do countless times in every analytical hour, we continually deflect his associations and rouse in him expected ideas, we smooth the way so that the connections between his thoughts so far as their content is concerned are, therefore, to a high degree active. . . . The difference between this and the ordinary suggestion

simply consists in this, that we do not deem the interpretations we offer to be irrefutable utterances, but regard their validity to be dependednt on whether they can be verified by material brought forward from memory or by means of repetition of earlier situations” (pp. 71-72).

Although the notion of anticipatory ideas did not reappear in Freud’s later writings, the idea of *constructions* was closely dependent upon it. In “Constructions in Analysis,” he wrote: “The analyst finishes a piece of construction and communicates it to the subject of the analysis so that it may work upon him; he then constructs a further piece out of the fresh material pouring in upon him [and] deals with it [sic] in the same way” (1937d, p. 260), adding, “We do not pretend that an individual construction is anything more than a conjecture which awaits examination, confirmation or rejection” (p. 265).

Thus, there were many safeguards against the excesses of analysts who were overly sure of the absolute accuracy of their interpretations. The dynamic relationship between analyst and patient that Freud highlighted here is that of a jointly undertaken search that, to be sure, presupposes a “historical truth” to be discovered, but with the reminder that this investigation is based on approximations whose limits are sometimes impossible to go beyond and must thus be accepted. It is this idea that Serge Viderman carried to its logical conclusion in his work on the “construction of the analytic space” (1970).

ALAIN DE MIJOLLA

See also: “*Constructions in Analysis*”; Idea/representation; Interpretation.

### **Bibliography**

- Ferenczi, Sándor (1960). On forced phantasies: Activity in the association-technique." In his *Further contributions to the theory and technique of psycho-analysis*. London: Hogarth Press. (Original work published 1924)
- Freud, Sigmund. (1901a). On dreams. *SE*, 5: 629–685.
- . (1909b). Analysis of a phobia in a five-year-old boy. *SE*, 10: 1–149.
- . (1910d). The future prospects of psycho-analytic therapy. *SE*, 11: 139–151.
- . (1912b). The dynamics of transference. *SE*, 12: 97–108.

———. (1916–1917a [1915–1917]). Introductory lectures on psycho-analysis. *SE*, 15–16: 1–463.

———. (1937d). Constructions in analysis. *SE*, 23: 255–269.

Viderman, Serge. (1970). *La Construction de l’espace analytique*. Paris: Denoël.

## **ANTILIBIDINAL EGO/INTERNAL SABOTEUR**

Fairbairn’s thinking on psychic structure began in 1929, with a critical study of Freud’s ideas about the superego (Fairbairn, 1929/1994b), and developed into his mature object-relations theory (1954), modifying the Freudian model. In Fairbairn’s revision (1952/1994a) of Freud’s concepts of endopsychic structure (1923), the term “antilibidinal ego” refers to the split-off and repressed ego-structure related to the rejecting object. In his earlier work it developed from his ideas about the superego and was termed the “internal saboteur.”

According to Fairbairn, the early unitary ego, rather than seeking pleasure, seeks relationships (intimacy) with the external object. Actual environmental failure (which in ideal circumstances maintains integration of the ego) leads to compensatory internalization of the object. The object is then defensively split into three objects. The unrepressed (central) ego, partly conscious and attached to the ideal object, represses the other two objects, the exciting (libidinal) object and rejecting (antilibidinal) object, together with the aspects of the ego related to them (the libidinal ego and antilibidinal ego, known as subsidiary egos). These repressed objects are termed “bad objects” and are unavailable for real object relations.

Fairbairn named the resulting situation the “basic schizoid position,” a term later taken up by Melanie Klein (1946/1952). The antilibidinal ego, attached to the rejecting object and unrelentingly hostile to the libidinal ego, reinforces the central ego in its repression of the libidinal ego. The degree of psychopathology depends on these splits, the amount and strength of central ego remaining, and the many possible patterns of internal relationships. Fairbairn saw disturbance as being due to the return of repressed bad-object experience to consciousness. Fairbairn’s dynamic structure, which differs from that of Freud, is wholly object-related. The concept of the schizoid position is fundamental to his thinking about the many possible variants of psychopathology. The elaboration of the

antilibidinal ego as differing from the superego, together with the theory of a psychic structure made up of many conflicted ego-object relationships, allows a flexible technical approach.

This thinking has been influential in Britain, most notably on the Independent Group, and on self-psychologists and intersubjective theorists in the United States.

JENNIFER JOHNS

See also: Fairbairn, William Ronald Dodds; Quasi-independence/transitional stage.

### Bibliography

Fairbairn, Ronald. (1954). *An object-relations theory of the personality*. New York: Basic Books.

———. (1994a). Endopsychic structure considered in terms of object relationships. In his *Psychoanalytic studies of the personality*. London: Tavistock Publications with Routledge and Kegan Paul. (Original work published 1952)

———. (1994b). What is the superego? In David E. Scharff and Ellinor Fairbairn Birtles (Eds.), *From instinct to self: selected papers of W. R. D. Fairbairn*, Vol. 2, *Applications and early contributions*. Northvale, NJ: Jason Aronson. (Original work published 1929)

Freud, Sigmund. (1923). The ego and the id. *SE*: 19: 19–27.

Grotstein, James, and Rinsley, Donald (Eds.). (1994). *Fairbairn and the origins of object relations*. London: Free Association Books.

Klein, Melanie. (1952). Notes on some schizoid mechanisms. In Joan Riviere (Ed.), *Developments in psycho-analysis*. London: Hogarth Press and the Institute of Psycho-analysis. (Original work published 1946)

---

## ANTINARCISSISM

The concept of *antinarcissism* was proposed by Francis Pasche in 1964. The context was a theoretical debate seeking initially to define narcissism and then to describe its role in psychic development.

The difficulties, complexities, and, for some, the aporias of narcissism led to two antithetical choices. Some abandoned the notion of primary narcissism, giving a fundamental role to the primary object-relation (this was true of the English school, Michael Balint, and John Bowlby). Others, like Paul Federn and Béla Grunberger, were led to separate narcissism

from the libido. This, it seemed to them, was necessary in order to account for the ubiquity of narcissism in mental life. But this was not the opinion of Francis Pasche, who chose to reintroduce a duality, or even a dialectic, into the concept of narcissism itself (1965).

Both narcissism and antinarcissism were characterized for Pasche by an object and a direction. The object was the same for both: the ego. The direction, however, was not the same: centripetal for narcissism, centrifugal for antinarcissism. Antinarcissism could be thought of as a centrifugal investment, in which the subject tends to be divested of the self, to give up their own substance and reserves of love, and to do this independently of any economic factors. In this sense, antinarcissism is actually a manifestation of Thanatos, that is, of unbinding separation and dispersion, but not of aggressiveness.

There is a striking convergence between Francis Pasche's conception of antinarcissism and what Sándor Ferenczi called, in his final writings, the "altruistic drive" (1949, fragment dated 24 August 1930).

André Green's work on narcissism is also germane here. Even if Green's negative narcissism does not correspond precisely to Pasche's antinarcissism, the two notions are akin.

MICHÈLE BERTRAND

See also: Narcissistic neurosis; Pasche, Francis Léopold Philippe; Psychoanalytic family therapy;

### Bibliography

Ferenczi, Sándor. (1949). Notes and fragments (1930–32). *International Journal of Psychoanalysis*, 30, 231–242.

Pasche, Francis. (1965). L'anti-narcissisme. *Revue française de psychanalyse*. XXIX, 5–6: 503–518; reprinted in *À partir de Freud*, Paris: Payot, 1969.

---

## ANTI-OEDIPUS: CAPITALISM AND SCHIZOPHRENIA

Gilles Deleuze and Félix Guattari's *Anti-Oedipus: Capitalism and Schizophrenia*, was originally intended to be the first volume of a two-volume work. The second volume, which was supposed to be entitled *Schizo-analysis*, never appeared under that title but was instead "replaced" by *A Thousand Plateaus*.

At the time of its publication in 1972, *Anti-Oedipus* had an explosive impact. In a state of high excitement, and still shaken by the events of May 1968, the French intelligentsia greeted this work by a renowned philosopher and an antiestablishment psychoanalyst as a revolutionary brick through the window of psychoanalysis. Deleuze said of his collaboration with Guattari, “We don’t work together, we work between the two of us”.

The Oedipus complex, which psychoanalysts describe as a fundamental and unavoidable step in the psychic structuring of the healthy child, was denounced by the authors as an “impasse.” The unconscious was a production, a fabrication, a flow. Accordingly, there was no such thing as a desiring subject, but rather flows of desire that are independent of and that traverse the subject. These points of traversal of desire, this flow, exists in opposition to lack, to the Law. “Lack (manque) is created, planned, and organized through social production.” Being essentially revolutionary, desire is the enemy of capitalist society, which psychoanalysis defends and protects.

The family is the first source of the work of repression operating in the flow of desire: “The family is thus introduced into the production of desire, and from earliest childhood it will effect a displacement of desire, an unheard-of repression.” All of capitalism’s efforts—and those of psychoanalysis—will go toward trying to maintain these flows of desire and “re-territorializing” them by imposing limits; on the interior, Oedipus, on the outside, as “the absolute limit of every society” (p. 266), schizophrenia: “The Oedipal triangle is the personal and private territoriality that corresponds to all of capitalism’s efforts at social reterritorialization” (p. 266).

The “schizo-analysis” invented by the authors is defined as “a whole scouring of the unconscious, a complete curettage” (p. 311). The thesis of schizo-analysis proposes that desire is a machine, in fact, interconnected machines—“desiring-machines.” This assemblage of machines represents the real and constitutes the production of desire. Psychoanalysis is described as a belief in a structural ensemble of the symbolic and the imaginary that Deleuze and Guattari characterize as a mythical belief. They radically challenge the Oedipus complex and accuse psychoanalysis of “beating down all the connections, the entire arrangement” because it “hates desire, hates politics.” The two authors reject the idea of any psychic reality: “There is only desire and the social, and nothing else.”

Schizo-analysis, with its schizophrenic process, a “political and social psychoanalysis” proposes to “undo the expressive oedipal unconscious, which is always artificial, repressive and repressed, and mediated by the family, to gain access to the immediate productive unconscious.”

The authors are careful to distinguish between schizophrenia as a structure and the schizophrenic as an entity. The latter is sick from the oedipalization that society attempts to impose upon him, but he represents the emblematic figure of the revolutionary, who is in a position to say, “Oedipus? Never heard of it” (p. 366). The schizophrenic process is revolutionary; its goal is to “show the existence of an unconscious libidinal investment of socio-historical production.” Here, schizo-analytic production is the opposite of psychoanalytic expression.

Proponents of antipsychiatry, in particular Ronald D. Laing, proved to be valuable allies to Deleuze and Guattari. In effect, madness is described not so much as a collapse but rather as a breakthrough. The goal of schizo-analysis is to enable the flows, to “tirelessly undo/defeat the egos and their assumptions.” and it “makes no distinction in nature between political economy and libidinal economy.”

In taking as their model the schizophrenic process and contrasting it with the oedipalized neurotic process, the authors constructed a seductive theory that was in keeping with its era. Marxist and structuralist elements are discernible. What are now referred to as “the events of May ’68” had not yet been entered into the history textbooks and the collective memory. The metaphor of schizophrenia, stretched to the limit by Deleuze and Guattari, was resonant in the context of a breakdown in the political order and the family. The disillusionments that followed are well known.

It is somewhat surprising to note that in the very extensive index of proper names in *Anti-Oedipus*, Sophocles is not mentioned once. This is of course indicative of the authors’ genuine intent to separate Oedipus as a psychic structure from Oedipus as a dramatic myth. It is the former, structural aspect of Oedipus that is fundamental to all civilizations. It is this Oedipus that is targeted by the authors, and not the dramatic figure of antiquity.

Indeed, *Anti-Oedipus* today appears as an anti-dramatic text, to be read as a comedy deriding capitalism and glorifying a schizophrenia invented and

amplified through the joint writing of a philosopher and a psychoanalyst engaged in critical reflection designed to challenge the bourgeois ideology of their era.

SYLVIE GOSME-SÉGURET

*See also:* France; Oedipus complex; Philosophy and psychoanalysis; Schizophrenia.

### Source Citation

Deleuze, Gilles, and Guattari, Félix. (1977). *Anti-Oedipus: Capitalism and schizophrenia*. (Robert Hurley, Mark Seem, and Helen R. Lane, Trans.). New York: Viking. (Original work published 1972)

### Bibliography

Deleuze, Gilles, and Parnet, Claire. (1977). *Dialogues*. Translated by Hugh Tomlinson and Barbara Habberjam. London: Athlone Press, 1987.

Lecourt, Dominique. (2001). *The mediocracy: French philosophy since the mid-1970s*. (Gregory Elliott, Trans.). London-New York: Verso. (Original work published 1999)

Le Goff, Jean-Pierre. (1998). *Mai 68, l'héritage impossible*. Paris: Le Découverte.

---

**ANTISEMITISM.** *See Racism, anti-Semitism, and psychoanalysis*

---

## ANXIETY

Anxiety is an unpleasurable affect in which the individual experiences a feeling of danger whose cause is unconscious. Freud had already begun considering the problem of anxiety in his correspondence with Wilhelm Fliess at the very start of his psychoanalytic work (1950a [1887–1902]). His subsequent efforts were more and more systematic as he developed two successive theories of anxiety.

In both of Freud's theories of anxiety a fundamental role is played by an absence of discharge, and hence of instinctual satisfaction. In his first account, the sexual instinct, undischarged, was described as being transformed explicitly into anxiety by a seemingly biological mechanism (1895b [1894]). Somatic sexual

excitation with the help of sexual ideas thus could not develop into psychic libido. However, sexual representations could be repressed, and their attendant excitation either diverted toward somatic outlets, so giving rise to hysterical conversion symptoms or, alternatively, redirected into the substitute representations typical of anxiety hysteria or phobic neurosis.

In Freud's second theory of anxiety, set forth in *Inhibitions, Symptoms, and Anxiety* (1926d [1925]), unsatisfied instincts were not explicitly evoked. In this account, anxiety as a signal is developed by the ego as a defensive measure against automatic anxiety. The infant's biological and mental immaturity does not enable it to confront the increase in tension arising from the enormous amounts of instinctual excitation that it cannot discharge and satisfy. This generates a state of distress that is traumatic for the newborn, triggering automatic anxiety. The infant gradually comes to understand that the maternal object can put an end to this state of affairs. It is then that the loss of the mother is experienced as a danger, and this experience constitutes anxiety as a signal.

When the newborn begins to perceive its mother, it is unable to distinguish temporary absence from enduring loss; thus from the moment the mother is lost sight of, the baby behaves as if it is never going to see her again. Repeated experiences of satisfaction have created this object, the mother, which, as need arises, is intensely cathected in a way that might be described as nostalgic. From this moment on, in Freud's view, object-loss provokes psychic pain, while anxiety is the reaction to the danger associated with that loss. Sadness arises whenever reality-testing forces an acknowledgment that the object has been lost. In its various forms, object-loss becomes the prototype of later anxieties, which Freud lists as: anxiety at the loss of the love of the object, castration anxiety, and anxiety at the loss of the love of the superego.

The novelty of this theorization derives, on the one hand, from the genetic notion according to which anxiety is tied to the fear of re-experiencing very early human states of distress, and on the other hand, from the fact that these states are associated during early infancy with various fantasies about the maternal object, and later with fantasies concerning other objects, including the father (castration anxiety or anxiety at the loss of the love of the superego). The close connection thus posited between anxiety

and ideation is radically at odds with Freud's first theory of anxiety.

Anxiety always occupied a central place in the work of Melanie Klein, first of all with respect to technique, and secondly in terms of theory. She stated repeatedly that her chief technical principle was that interpretation must focus on the point of maximum anxiety. Equilibrium between the life instincts and the death instincts was fundamental to Klein's understanding of the different forms of anxiety and the fantasies that expressed them. In her earliest writings, she associated anxiety and its related inhibitions with sexual conflicts of childhood bound up with the Oedipus complex. At the same time, however, she was struck by the scope of aggressive fantasies in young children, especially during what she called the phase of maximal sadism. She gradually came to view the child's aggressiveness towards the mother's body and its fantasy contents (penis, baby, feces, etc.) as responsible for an anxiety based on the fear of the reciprocal aggression it could provoke. The danger intrinsic to anxiety was thus seen as the result of the subject's excessive aggressiveness.

Although to begin with Klein's theory leaned heavily on Freud's *Inhibitions, Symptoms, and Anxiety*, from 1935 on, and especially after 1940, with the gradual working out of the concept of the "depressive position," she assigned object-loss a central role. This implied a change in the conceptualization of anxiety, which acquired a depressive character: anxiety was now seen as expressing "pain," which for Klein included both suffering and sadness in Freud's sense. Anxiety states were engendered by lived experiences of object-loss that were more or less definitive and irreversible.

Since experiences of loss were closely associated with the damage wreaked in fantasy by aggressive impulses, painful feelings were accompanied by feelings of conscious or unconscious guilt. This guilt generally tended to remain unconscious because of the great importance it assumed for the subject, who attributed an all-powerful destructiveness to his own aggression. The ego would then turn to radical (psychotic, manic, or depressive) defenses, which also made it difficult for painful feelings to gain access to consciousness. On the other hand, the more real the guilt, the more vigorously it would be supported by the ego, clearing a path to consciousness by way of feelings of sadness. A basic exception to this rule were the strong guilt feelings manifested by melancholics, whose self-reproach masked an

attempt by the ego to overwhelm the introjected and attacked object with guilt.

After introducing the "paranoid-schizoid position" (1946), which she contrasted with the depressive position as a type of psychic functioning, Melanie Klein was able to develop a systematic theory of anxiety and guilt (1948). The theory relied primarily on Freud's concept of the death instinct, which Klein had adopted. In this view, anxiety was provoked by the danger with which the death instinct threatened the organism. Klein spoke of anxiety about "annihilation" and "fragmentation" with reference to very primitive terrors triggered by the inner working of the death instinct and with reference to the paranoid anxiety generated by persecutory objects or by the primitive superego. In this sense fragmentation anxiety may be considered a very archaic precursor of castration anxiety.

In the face of maternal frustration, Klein contended, the sense of an internal threat created by the death instinct reinforces the projection of destructive impulses by the primitive ego of the paranoid-schizoid position. As a consequence the breast as "bad" part-object becomes the source of "paranoid" or persecutory anxiety. Another portion of the death instinct is used by the ego in the form of aggression to attack the persecutory object. Introjection of both the persecutory breast and the persecutory penis is the foundation of the primitive superego, which is at first difficult to distinguish from internal persecutory objects since it provokes very intense persecutory anxiety (fear of fragmentation). This very early superego, in spite of its aggressiveness, strives to protect the libidinal bonds that the ego is meanwhile forming with good or idealized objects, which are experienced as the source of life.

As progress is made, with the help of libidinal instincts, toward the successful integration of aggression, fantasies arise, characteristic of the early stages of the Oedipus complex, involving part-objects in the process of being made whole: the mother's stomach and its fantasized contents (penis, baby, feces, etc.). If such objects provoke psychotic persecutory anxieties, these will manifest themselves clinically as the outcome of a defensive transformation of intolerable depressive anxieties produced under pressure from an overly aggressive primitive superego. In fact, as Klein indicated in her last writings, the paranoid-schizoid and depressive positions act simultaneously, whether in the service of defense or of integration. In clinical work, this is reflected in the coexistence of paranoid

and depressive anxieties; one or the other will prevail, depending on which position is predominant in the patient.

During the various steps in the integration of the depressive position, a whole range of depressive anxieties is encountered, as distinguished by the particular fantasies that attend the loss of the libidinally cathected object in each type of case (Palacio Espasa, 1993). Thus whenever fantasies of catastrophic destruction come to the fore and the damage is experienced by the subject as irreparable because of the great force of his aggression, as he perceives it, the intensity of the ensuing guilt makes the pain and sadness hard to bear. The ego can only resort to psychotic defenses that transform these disastrous depressive anxieties into persecutory anxieties.

Where fantasies of destruction are less significant, and the subject's aggressiveness is experienced as less destructive, fantasies of the death of libidinally cathected objects may be prevalent. The ego can then use its store of libido, which it experiences as limited, as a massive barrier to any manifestation of aggression. This arouses intense feelings of guilt, and hence of responsibility for fears of death or of object-loss. The ego tends to defend itself against such painful depressive affects either in manic fashion, through identification with idealized and intact objects, or else by melancholic means, such as identification with the dead or destroyed aspects of objects.

When fantasies of loss of the object's love predominate, they center on rejection or abandonment by the object. Death fantasies are less intense and are experienced as more easily reversible because of the greater libidinal capacity available to the ego of subjects in this category. Under these circumstances the ego has a whole panoply of neurotic defenses at its disposal. These include the retroactive denial of the ill consequences of the subject's aggression and reaction-formations against aggression of a typically obsessive-neurotic kind. By means of phobic displacement and symbolization, a predominance of libidinal impulses facilitates the transformation of the conflict provoked by the loss of the object's love into a triangular conflict in which fantasies of exclusion become more prominent. Given well-integrated instinctual relationships with two highly cathected parental imagos, the experienced object-loss may be reduced to that of the loss of the incestuous object's exclusive love. On the other hand, the dangerous aggressiveness deemed

responsible for the loss of the object's love may be projected onto the other parent, who then becomes a rival. An oedipal situation is thus created, along with the various conflicts, directly or indirectly expressed, that characterize the Oedipus complex.

In short, as the intensity of depressive anxieties decreases, the Oedipus complex comes to the fore thanks to the transformation of depressive conflict into a variety of neurotic conflicts that generate castration anxiety. In neurosis, however, along with castration anxiety intense depressive anxieties (especially guilt) may continue to exist with respect to the oedipal parents—more complete objects, often neglected in the literature on neurosis. Such anxieties may indeed occasion significant regression back toward depressive conflict.

In psychoanalytic theory castration anxiety is closely bound up with the Oedipus complex. For Freud castration is one of the primal fantasies. In his view of childhood sexuality, the Oedipus complex makes its appearance during the stage of phallic primacy, which means that castration anxiety is rather similar in the two sexes. Because of the overvaluation of the phallus, the child does not recognize the female sex as such and considers it to be the result of castration. In *Inhibitions, Symptoms, and Anxiety* Freud sees castration as one loss, on the level of genital sexuality, in a series of object-losses: the loss of the mother's breast, the loss of the contents of the intestines, and so on.

For Melanie Klein castration anxiety develops as a fear of reprisal for the child's oedipal rivalry with the parent of the same sex. In boys this becomes an anxiety about the loss of the penis at the hands of a vengeful father; in girls it becomes an anxiety about attacks against her own belly by the persecuting maternal object. From this theoretical standpoint, castration anxiety appears as a form of punishment for the manic and narcissistic fantasies constructed by the young child as protection against its feelings of exclusion from the sexual and genital relations of the parents, to which it does not have access because of its biological immaturity. The infant then takes possession in fantasy of the idealized sexual attributes of the parent of the same sex, who thus becomes a rival, and imagines it is the exclusive recipient of the love of the parent of the opposite sex. Such a fantasy position can only generate castration anxiety, if for no other reason than that it derives from the infant's apprehension of its own biological immaturity as a mutilation.



Separation anxiety appears when the subject experiences separation as a more or less irreversible object-loss. In the descriptions given by Margaret Mahler, the very young infant manifests separation anxieties after the fifth or sixth month, and they become especially significant between 15 and 18 months of age, during the *rapprochement* subphase of the separation-individuation (Mahler et al.). During this time the baby experiences real despair, feelings close to the nascent melancholy that Klein describes as occurring at the height of the depressive position. The presence of the external mother is essential, for her internal image is experienced as very much under threat from the child's aggressive fantasies, perceived by the child as massive and highly destructive. Only after the age of two or three, during the phase of object constancy, does the child become able little by little to overcome separation anxiety; by then it can retain an inner mental representation of the mother that is cathected for the most part by libidinal impulses.

Anxiety in the presence of actual danger, or "realistic anxiety," is a somewhat paradoxical concept employed by Freud in *Inhibitions, Symptoms, and Anxiety*, where (as we have seen) he views anxiety as arising from a felt danger from within occasioned by object-loss. Freud himself resolves the ambiguity when he asserts, in discussing apparently external dangers such as the loss of the object's love, or castration anxiety, that "the loved person would not care to love us nor should we be threatened with castration if we did not entertain certain feelings and intentions within us. Thus such instinctual impulses are determinants of external dangers and so become dangerous in themselves" (p. 145). In other words, all realistic anxiety is also anxiety *tout court*, and not simply fear of an external danger, for it always arouses an internal threat. This idea is crucial, of course, to the Kleinian concept of the depressive position, where every outside loss is accompanied by an experience of the loss of internal objects. Primitive experiences of loss are reactivated by the real loss, so that the working-through of such early internal losses is a prerequisite if objects lost in the outside world are to be successfully mourned.

FRANCISCO PALACIO ESPASA

*See also:* Abandonment; Annihilation anxiety; Anxiety dream; Aphanisis; Claustrophobia; Counterphobic; Defense; Ego; Fear; Hypochondria; Hysteria; *Inhibitions, Symptoms, and Anxiety*; "Neurasthenia and Anxiety

Neurosis"; *Nervous Anxiety States and their Treatment*; Nightmare; Paranoid-schizoid position; Phobias in children; Primitive agony; Quota of affect; Seminar, Lacan's; Signal anxiety; Specific action; Stranger, fear of; Substitutive formation; *Trauma of Birth, The*.

### Bibliography

- Freud, Sigmund. (1895b [1894]). On the grounds for detaching a particular syndrome from neurasthenia under the description "anxiety neurosis." *SE*, 3: 87–115.
- . (1926d [1925]). Inhibitions, symptoms and anxiety. *SE*, 20: 87–172.
- . (1950a [1887–1902]). Extract from the Fliess papers. *SE*, 1: 173–280.
- Klein, Melanie. (1946). Notes on some schizoid mechanisms. *International Journal of Psycho-Analysis*, 27, 99–110.
- . (1948). On the theory of anxiety and guilt. *International Journal of Psycho-Analysis*, 29, 113–123.
- Mahler, Margaret S., Pine, Fred, and Bergman, Anni. (1975). *The psychological birth of the human infant*. New York: Basic Books.
- Palacio Espasa, Francisco. (1993). *La pratique psychothérapeutique avec l'enfant*. Paris: Bayard.

### Further Reading

- Hurvich, Marvin. (1997). "The ego in anxiety" & "Addendum to Freud's theory of anxiety". *Psychoanalytic Review*, 84, 483–504.
- . (2000). Fear of being overwhelmed and psychoanalytic theories of anxiety. *Psychoanalytic Review*, 87, 615–650.
- Roose, Stephen P., and Glick, Robert. A. (Eds.). (1995). *Anxiety as symptom and signal*. Hillsdale, NJ: Analytic Press.

---

**ANXIETY AS SIGNAL.** *See* Signal Anxiety

---

### ANXIETY DREAM

A dream may be so charged with anxiety that the dreamer can escape only through waking. Sometimes the dreamer is then amazed by the disparity between the intensity of emotion and the apparent banality of the dream itself. This is the classic "anxiety dream." Freud offered a detailed analysis of such a dream in his case history of the "Wolf Man" (1918b [1914]).

Freud often returned to the problem of anxiety dreams, because, as he wrote in *The Interpretation of Dreams*, “It does in fact look as though [they] make it impossible to assert as a general proposition . . . that dreams are wish fulfillment; indeed they seem to stamp any such proposition as an absurdity” (1900a, p. 135). Freud’s answer to the puzzle about anxiety dreams holds fast to the basic principle of dream-formation: that even when the content of the dream is clearly distressing, its latent content involves fulfillment of a wish.

From this point of view, Freud analyzed one of Dora’s dreams (1905e [1901]), a dream of Norbert Hanold in *Delusions and Dreams in Jensen’s “Gradiva”* (1907a [1906]), a dream of “Little Hans” (1909b), and most noteworthy, the wolf dream of Sergeï Pankejeff, the “Wolf Man” (1918b [1914]). Freud returned at length to this thesis in the chapter on wish fulfillment in *Introductory Lectures on Psycho-Analysis* (1916–1917a [1915–1917]).

With respect to recurrent anxiety dreams in cases of traumatic neuroses, Freud altered his views somewhat in “Revision of Dream Theory,” chapter 29 of *New Introductory Lectures on Psycho-Analysis* (1933a [1932]), where he asserted, “A dream is an attempt at the fulfillment of a wish. . . . In certain circumstances a dream is only able to put its intention into effect very incompletely, or must abandon it entirely. . . . While the sleeper is obliged to dream, because the relaxation of repression at night allows the upward pressure of the traumatic fixation to become active, there is a failure in the functioning of his dream work, which would like to transform the memory-traces of the traumatic event into the fulfillment of a wish” (p. 29). Although Freud did not highlight the change in this text, the fundamental revision to his theory of dreams perhaps came earlier, in *Beyond the Pleasure Principle* (1920g [1914]).

ROGER PERRON

*See also:* Anxiety; Dream.

### **Bibliography**

- Freud, Sigmund. (1900a). The interpretation of dreams. *SE*, 4: 1–338; 5: 339–625.
- . (1905e [1901]). Fragment of an analysis of a case of hysteria. *SE*, 7: 1–122.

———. (1907a [1906]). Delusions and dreams in Jensen’s “Gradiva.” *SE*, 9: 1–95.

———. (1909b). Analysis of a phobia in a five-year-old boy. *SE*, 10: 1–149.

———. (1916–1917a [1915–1917]). Introductory lectures on psycho-analysis. *SE*, 15–16.

———. (1918b [1914]). From the history of an infantile neurosis. *SE*, 17: 1–122.

———. (1920g). Beyond the pleasure principle. *SE*, 18: 1–64.

———. (1933a [1932]). New introductory lectures on psycho-analysis. *SE*, 22: 1–182.

### **Further Reading**

- Eissler, Kurt R. (1966). A note on trauma, dream, anxiety, and schizophrenia. *Psychoanalytic Study of the Child*, 21, 17–50.

---

**ANXIETY HYSTERIA.** *See* **Hysteria**

---

**ANXIETY NEUROSIS.** *See* “**Neurasthenia and ‘Anxiety Neurosis’**”

---

**ANXIETY SIGNAL.** *See* **Signal anxiety**

---

## **ANZIEU, DIDIER (1923–1999)**

French psychoanalyst and professor of psychology Didier Anzieu was born July 8, 1923, in Melun and died on November 25, 1999, in Paris.

His parents, who worked for the post office, met in Melun, where Didier Anzieu spent his childhood and part of his adolescence. A younger sister died at birth. His parents’ intense investment in Didier, especially on the part of his mother, Marguerite, who became seriously depressed after the stillbirth of her daughter (she herself was a “survivor,” her sister having died when she was a child), led to alternations between “superimposed layers of care” and feelings of

abandonment that would mark Anzieu's life and work. His mother's illness and subsequent treatment in a psychiatric hospital further distanced him from her; he was raised by his maternal aunt, who later moved in with her brother-in-law.

His close, secure, and warm relationship to his father sustained him throughout his childhood and entrance into adult life. He began his secondary school studies in Melun, followed by Paris, where he met Zacharie Tourneur, with whom he edited Pascal's *Pensées*. After the *École Normale Supérieure* and his studies in philosophy, he turned to psychology, which he taught, along with Daniel Lagache, at the Sorbonne, before continuing his academic career in Strasbourg (1955–1964) and Paris (1964–1983). In 1957 he completed his oral defense for the doctoral degree, the subject being Freud's self-analysis and its role in the invention of psychoanalysis.

Before he became a psychoanalyst Didier Anzieu worked as a clinical psychologist. His involvement in psychology led him through several fields of study: psychodrama, dermatology, projective methods, and Rorschach methods, in which he specialized. He made use of the dynamics of Lewinian groups in creating, in 1962, an association—CEFFRAP, the *Centre d'études françaises pour la formation et la recherche active en psychologie*—through which he set up the first French experiments in group psychoanalysis and group psychodrama. Anzieu's various activities supported a brilliant academic career alongside his work as an editor and creative writer (short stories, essays, drama).

As a psychoanalyst, Anzieu's life intersected his personal history, his psychoanalytic history, and the history of the French psychoanalytic movement. His mother, Marguerite Anzieu, had been treated by Jacques Lacan, who had used her treatment as the basis for his medical dissertation *De la psychose paranoïaque dans ses rapports avec la personnalité* (*On Paranoid Psychosis in Its Relations with the Personality*), published in 1932, in which she is known simply as "Aimée." Didier Anzieu began psychoanalysis with Lacan in 1949. After four years of fruitful work, their relationship became problematic when Lacan asked him to remain silent about how therapy was being conducted. Anzieu continued his training (1953) with Daniel Lagache, Juliette Boutonier, and Georges Favez. He participated in the foundation of the French Psychoanalytic Association when it was formed in 1964 following the break with Lacan, and assumed a num-

ber of responsibilities within the association (he was its vice-president).

Anzieu's psychoanalytic writing can't be separated from his other writing, his activity as a psychoanalyst, or his interests. It is both varied and indivisible, always informed by the uncertainties of psychology, literature, and the psychoanalysis of intersubjective bonds.

In his psychoanalytic practice, Anzieu always claimed to be an orthodox analyst, but he was also careful to modulate the mechanism and technique of interpretation according to the treatment needs of the individual patient. As he refined his theoretical understanding through clinical activity, he highlighted the transformations needed in the object of interpretation (the "archaic") and in the handling of a reliable and flexible framework that harmonized with the specific transferences generated by the pathologies of the primal. He gave increasing attention to these areas of practice, which were supported by his contacts with the Anglo-American school (Melanie Klein, Wilfred R. Bion, Donald W. Winnicott, Esther Bick). He was also interested in the unconscious formations and processes involved in group bonds and the work of creation. A statement written in 1975 expresses his fundamental position: "The question is not to repeat what Freud found when faced with the crises of the Victorian era, but to find a psychoanalytic response to mankind's malaise in the civilization in which we live. Work such as that of psychoanalysis needs to be done wherever the unconscious arises, standing, seated or lying down; individually, in a group or in a family, wherever a subject can allow his anxieties and fantasies to speak out to someone who is supposed to listen to them and is likely to help him understand them."

Anzieu's worldwide recognition is largely due to his scrupulous approach to clinical and theoretical work and his intellectual freedom in searching for innovative tools. He renewed the understanding of self-analysis and dream interpretation, primordial models for what he would later theorize as the work of creation and processes of thought.

He introduced new concepts into psychoanalytic theory. With the important concept of the "skin ego" (1985/1989), he referred to "a figuration the child's ego makes use of during the precocious phases of its development to represent itself as an ego containing psychic contents based on its experience of the surface of his body." This concept inaugurated several research projects on psychic interfaces and envelopes,

on the dual prohibition of touching, on formal signifiers and their normal and pathological transformations. These investigations gave rise to a theory of thought processes and a conception of the work in which the dual polarity of creation and destruction is affirmed.

Didier Anzieu made use not only of clinical psychoanalysis but literature (Pascal, Julien Gracq, Alain Robbe-Grillet, Samuel Beckett) and the visual arts as well (Francis Bacon) to bring to light the traces of the body in writing, drama, and painting. Finally, through his work on individual and group psychoanalytic psychodrama, he enriched the instruments derived from psychoanalysis by proposing a new outlook on the operation of the unconscious in groups.

RENÉ KAËS

*Work discussed:* Freud's *Self-Analysis*.

*Notions developed:* Heroic identification; Skin ego.

*See also:* Aimée, case of; Analytic psychodrama; Body image; France; Group analysis; Lacan, Jacques-Marie Émile; Literature and psychoanalysis; *Nouvelle Revue de psychanalyse*; Paradox; Protective shield; Psychic envelope; Psychoanalytic family therapy; Psychological tests; Self-analysis; Skin; Thought.

### **Bibliography**

- Anzieu, Didier. (1959). *L'autoanalyse*. Paris: Presses Universitaires de France.
- . (1989). *The skin ego* (Chris Turner, Trans.). New Haven-London: Yale University Press. (Original work published 1985)
- . (1987). Some alterations of the ego which make analyses interminable. *International Journal of Psycho-Analysis*, 68 (1), 9–20.
- . (1989). Beckett and Bion (Juliet Mitchell, Trans.). *International Review of Psycho-Analysis*, 16 (2), 163–170.
- . (1979). The sound image of the self. *International Review of Psycho-Analysis*, 6 (1), 23–36.
- Kaës, René. (1994). *Les voies de la psyché, hommage à Didier Anzieu*. Paris: Dunod.

## **APHANISIS**

The term “aphanisis” merits an entry in Laplanche and Pontalis's *The Language of Psychoanalysis*, where

its principal definition is as follows: “Term introduced by Ernest Jones: the disappearance of sexual desire. According to Jones aphanisis is the object, in both sexes, of a fear more profound than the fear of castration.”

It was in 1927 that Ernest Jones called upon this concept in his work on the precocious development of feminine sexuality. Etymologically the term comes from the Greek *aphanisis*, which refers to an absence of brilliance in the astronomical sense, to disappearance or becoming invisible (of a star for example).

Jones applied this concept in a psychoanalytic sense in seeking to account for the disappearance of sexual desire in light of the castration complex; at the same time, he stressed that in his view there was no strict correlation between castration and the disappearance of sexuality: “many men wish to be castrated for, among others, erotic reasons, so that their sexuality certainly does not disappear with the surrender of the penis.” (1927, p. 439–440)

In other words, the concept of aphanisis, according to Jones, was much broader than that of castration, and if the two notions sometimes appeared to merge, it was only because the figure of castration was in some way emblematic of the suppression of sexual desire, for which it supplied a concrete (but in fact inaccurate) representation.

Laplanche and Pontalis (1967) observe that in women the fear of aphanisis is discernible beneath the fear of separation from the loved object, which is consistent with the fact that Jones introduced the notion apropos of feminine sexuality.

While Sigmund Freud described the psychosexual development of the boy along phallogocentric lines, Jones, for his part, tried to describe the sexuality of the young girl not by exclusive reference to penis envy (*Penisneid*), but as a sexuality having direct aims and modalities of its own. And it is precisely aphanisis, prior to the castration complex, that can furnish a kind of common basis for the sexual development of both sexes.

About thirty years after Jones introduced it, in 1963, John Bowlby took up the concept of aphanisis again in his critical review of separation anxiety. He made aphanisis one of the possible bases for understanding this developmental phenomenon. The disappearance of the object in fact confronts the infant

with the fear of no longer being able to focus its instinctual impulsive movements, and thus with the risk of losing the very possibility of the pleasure of desire as well.

Today the concept of aphanisis as such is little used in the context of metapsychological work; it has doubtless been relegated to the background by the redoubtable expansion of the theory of attachment.

BERNARD GOLSE

*See also:* Annihilation anxiety; Femininity; Jones, Ernest; Object *a*; Phallus.

### **Bibliography**

Bowlby, John. (1961). Separation anxiety: A critical review of the literature. *Journal of Child Psychology and Psychiatry*, 1, 251–69.

Ernest, Jones. (1950). Early development of female sexuality. In *Papers on psychoanalysis*. London: Bailliere, Tindall and Cox. (Original work published 1927)

Laplanche, Jean, and Pontalis, Jean-Bertrand. (1967). *The language of psychoanalysis*. Paris: Presses Universitaires de France.

---

## **APHASIA**

Aphasia, a word proposed by Armand Trousseau to replace the term “aphemia,” created by Paul Broca, refers to language disturbances that arise from specific cerebral lesions, most often in the cortex. Between 1861 and 1865, when the dispute ended concerning the question of determining whether the cerebral cortex operated as a unit or as a collection of separate elements, Paul Broca showed, through a series of anatomical and clinical observations, that the destruction of the left side of the base of the third circumvolution of the frontal lobe in a right-handed subject who until then was able to speak normally led to the loss of articulate language. The subject was unable to express himself using a sequence of words or phrases.

In 1874 Carl Wernicke extended the field of research by describing two other types of aphasia, all caused by a lesion in the left hemisphere: sensory aphasia from damage to the posterior areas of the second and third circumvolution of the cortex, and conduction aphasia, arising from the disconnection of

the bundles connecting this region to the base of the third circumvolution of the frontal lobe. Afterwards, the disturbance identified by Broca would be known as “motor aphasia.” Later Wernicke identified two other types of aphasia: “motor transcortical aphasia” and “sensory transcortical aphasia.”

By the end of the nineteenth century, three separate approaches to the problem had been developed. Some researchers, such as Jean Martin Charcot and Joseph Grasset, increased the number of types of aphasia; others, like Alfred Vulpian, and later Pierre Marie, renewed the “unitarian” position; the third group, following the important work by Jules Déjerine, demonstrated through the use of clinical and anatomical arguments that the nature of the aphasia would change with the nature and location of the lesion. For example, frontal lesions seemed to primarily affect speech production, posterior lesions seemed to affect speech recognition, and the destruction of the cortex resulted in disturbances of internal language, which affected the subject’s autonomy.

Sigmund Freud’s work on aphasia, published in 1891, accepts the work of Paul Broca but questions Wernicke’s research, which Freud criticizes for being excessively schematic and lacking in clinical observations. Freud did not question the relationship of language function with the brain but was cautious about hastily assigning specific locations to specific functions. Although he accepts that certain clinically based forms of aphasia—“verbal aphasia,” “asymbolic aphasia,” “agnosic aphasia”—can be used to localize the cortical lesion with certainty (which was later confirmed by neurosurgery during the First World War), he refused to extrapolate from pathology to physiology and deduced a cerebral concept of the normal operation of language, with a critical position that was far removed from the scientism that is often attributed to him in this field. In the descriptive sections of his work, Freud distinguished between the representation of words and the representation of things, and their links with auditory images, visual images, and the motor images at work in these phenomena.

GEORGES LANTÉRI-LAURA

*See also:* Brain and psychoanalysis, the; Language and disturbances of language; memory; Thing-presentation; Word-presentation.

### Bibliography

Freud, Sigmund. (1891b [1953]), *On aphasia (A critical study)* (E. Stengel, Trans.). New York: International Universities Press.

Hécaen, H. and Lantéri-Laura, Georges. (1977). *Évolution des connaissances et des doctrines sur les localisations cérébrales*. Paris: Desclée de Brouwer.

———. (1989). *Les fonctions du cerveau*. Paris: Masson.

Lantéri-Laura, Georges. (1993). *Histoire de la phrénologie*. Paris: Presses Universitaires de France.

### Further Reading

Miller, Laurence (1991). On aphasia at 100: the neuropsychodynamic legacy of Freud. *Psychoanalytic Review*, 78, 365-378.

Rizzuto, Anna-Marie. (1990). Origin of Freud's concept of object representation: "On Aphasia." *International Journal of Psychoanalysis*, 71, 241-248.

## APPLIED PSYCHOANALYSIS AND THE INTERACTIONS OF PSYCHOANALYSIS

Aside from being a theory of the unconscious, psychoanalysis as a method is used as an investigative tool in a wide variety of fields, the treatment of neuroses being only one among many. The term *applied psychoanalysis* is often used to refer to fields other than psychoanalysis or psychotherapy, particularly literature, art and culture. The term is therefore likely to have a range of accepted meanings that is either very broad, as in the case of collective phenomena, or narrowly restricted, as in the case of individual works of art.

The idea of *application*, to the extent that it presupposes use outside a field of origin, has often been criticized for introducing the risk that psychoanalysis will be used abstractly or mechanistically. This was certainly not the opinion of Sigmund Freud, who felt that most psychoanalytic concepts were buttressed by the great myths and works of literature, such as Sophocles's *Oedipus the King*, Michelangelo's *Moses*, and Shakespeare's *Hamlet*, which he mentioned in his letter to Wilhelm Fliess on October 15, 1897. Freud's later writings made use of the work of Wilhelm Jensen, Dostoevsky, and others. There are also numerous references to Goethe woven into the fabric of his thought. In this context we cannot really speak of application but, rather, of different modes of expression for the investi-

gation of what it means to be human. This proximity of culture and psychoanalysis also has the effect of mitigating the field's association with medicine, which was indeed one of Freud's objectives.

Freud's writings are interspersed with texts that are not specifically about psychopathology but contribute to its development indirectly. *Jokes and their Relation to the Unconscious* (1905c), "Psycho-Analysis and the Establishment of the Facts in Legal Proceedings" (1906c), *Delusions and Dreams in Jensen's "Gradiva"* (1907a [1906]), "Obsessive Actions and Religious Practices" (1907b), all written over a period of two years, reveal the variety of fields to which Freud applied the psychoanalytic method. More generally, psychoanalysis appears to embrace the fields of both individual therapy and collective phenomena, although we cannot speak of applied psychoanalysis in the latter case. Examples include *Totem and Taboo* (1912–1913a), *Group Psychology and the Analysis of the Ego* (1921c), "The Acquisition and Control of Fire" (1932a[1931]), and *Moses and Monotheism* (1939a [1937–1939]). Given the importance of these texts and their theoretical richness, "applied psychoanalysis" in the broad sense loses its meaning.

An especially rich and frequently examined field is the psychoanalysis of works of literature and the plastic arts. When it turns its attention to the artist or author, the psychoanalytic approach is not really far removed from its psychotherapeutic role. Freud himself emphasized the proximity between the case study and the novel, asserting that his case studies could be read as novels (1895d) and that novelists knew more about the unconscious than psychoanalysts.

Yet, the matter is not quite as simple as it appears. Although studying an author's biography is relevant for understanding his or her writing, such an examination should not be reduced to a form of pathography. Isidor Sadger was referred to as a *bungler* (Nunberg and Federn, 1962–75) and Max Graf, supported by Freud, pointed out that an author's neurosis does not explain his work. In "Creative Writers and Day-dreaming" (1908e [1907]), Freud shifted his focus to the question of the author's creativity with the hypothesis of a relation between the daydream and the themes of literary creation. He also questioned the nature of the reader's pleasure.

In 1912 the review *Imago*, published by Freud with the help of Otto Rank and Hans Sachs, printed articles on psychoanalysis applied to works of art, but even

earlier, in 1910, Freud's study of Leonardo da Vinci (1910c) had shown the protean nature of this type of psychoanalytic investigation. This was a study of a "childhood memory" of da Vinci's, and the earliest impressions of his life; it also provided an occasion to develop the theory of sublimation in its various versions, along with a new approach to male homosexuality.

Freud's paper on da Vinci is a good example of the impossibility, when referring to research devoted to a work of art (*The Virgin, Infant Jesus, and Saint Ann*) and its author, of limiting oneself to a single "application" of the psychoanalytic method. This, with all the risks it entails (mistaking the kite for a vulture), is creative because it directs toward the analysis of the work of art hypotheses and intuitions that could have come into being elsewhere or differently, blending episodes of therapy with a self-analytic approach (Freud's fantasy relationship with Leonardo).

Conversely, Freud's study of Michelangelo's Moses (1914b) ignored the facts of the artist's life. The interpretation is based on the feelings of the viewer, Freud in this case, and his understanding of the Bible. He explicates the work using the same method used for dreams, teasing out what is hidden or secret by means of details that are barely visible. Freud does not sharply distinguish between interpretation of the work of art and reconstruction of the author's fantasies, and when he turns to Jensen's *Gradiva* (1907a [1906]), it is only as an afterthought that he questions the author about the actual existence of a young girl with a club foot whom the author was supposed to have known in childhood.

The term "applied psychoanalysis" does not seem to be appropriate when we consider that for Freud—as for many psychoanalysts like Karl Abraham, Otto Rank, Wilhelm Stekel, Max Graf, Theodor Reik, and Fritz Wittels—it was not a question of demonstrating that the psychoanalytic method could be used outside the context of therapy (Laplanche proposed the expression, "extramural psychoanalysis"), but of developing hypotheses concerning this method within a field of research other than therapy.

Aside from the psychoanalysis of works of art, Freud highlighted the interest of psychoanalysis (1913j) not only for psychology but for the other sciences. By "interest" he meant the implications—being in (*inter-esse*)—of psychoanalysis for the other sciences, which can make use of psychoanalysis as a means of self-enrichment and even self-analysis. Thus

linguistics could draw on dreams and symbols for the study of language, philosophy could make use of the psychography of philosophers, and biology could borrow the opposition between ego instinct and sexual instinct to identify the opposition between an immortal germ plasma and isolated individuals. Similarly, the history of civilization could make use of the psychoanalytic approach to myth to help explain religion.

Nearly fifteen years later, in *The Question of Lay Analysis*, Freud wrote, "As a 'depth psychology,' a theory of the mental unconscious, it can become indispensable to all the sciences which are concerned with the evolution of human civilization and its major institutions such as art, religion, and the social order. It has already, in my opinion, afforded these sciences considerable help in solving their problems. But these are only small contributions compared with what might be achieved if historians of civilization, psychologists of religion, philologists and so on would agree themselves to handle the new instrument of research which is at their service. The use of analysis for the treatment of the neuroses is only one of its applications; the future will perhaps show that it is not the most important one" (1926e, p. 248).

Of course it is not necessarily the case that the benefit of psychoanalysis for the sciences is a one-way process. Just as the "application" of psychoanalysis outside therapy leads to discoveries that affect therapy through a deepening of theory and method, it benefits psychoanalysis to be questioned by the sciences with which it interacts. The "interactions of psychoanalysis" (Mijolla-Mellor, S. de) highlight the fact that it is impossible to focus psychoanalysis on a specific domain without the validity of its own methodology being questioned in turn. Such interactions assume the pursuit of a renewed epistemological investigation of the value of the psychoanalytic method and its ability to encounter other logics. This not only provides new insight into the field of application but also helps clarify the essential nature and potential for growth of psychoanalysis itself. The principal reason for this fecundity lies in the ability of psychoanalysis to allow itself to be questioned, and enriched, by, the fields of inquiry toward which it is directed.

Here, the cultural object or scientific discourse itself may exhibit a certain resistance (much like a patient) because they function according to their own logic and presuppositions, which in principle acknowledge no unconscious dimension. To introduce this dimension

into other domains means that the psychoanalyst must become newly aware of this object suspending the work of interpretation and, above all, questioning its ability not only to account for the facts in question but also for the way in which they are viewed and cathected.

The multidisciplinary interactions of psychoanalysis thus require an ongoing epistemological investigation of major importance, and which risks being undermined if psychoanalysts limit their inquiry to the therapeutic situation alone. This perspective is epistemological first and foremost, opening up the possibility of borrowing other models and allowing for conceptual fusion; but it also shows up the abiding (at times) specificity of fields of knowledge, and even their impermeability—and hence the limits of these interactions.

The common goal of research in the field of “interactions with psychoanalysis” is an awareness not only of the impact of Freud’s discovery of the unconscious on the humanities (*Geisteswissenschaften*) but also of the effects of models specific to those domains on psychoanalysis itself, as theory and as method, whenever it attempts to “interact.”

SOPHIE DE MIJOLLA-MELLOR

*See also:* *American Imago*; Anthropology and psychoanalysis; *Christians and Jews: A Psychoanalytical Study*; Cinema (criticism); Cinema and psychoanalysis; Civilization (*Kultur*); “Claims of Psychoanalysis to Scientific Interest”; Criminology and psychoanalysis; *Delusions and Dreams in Jensen’s “Gradiva”*; Don Juan and the Double; “Dream and Myth”; École Freudienne de Paris; Ethnopsychology; Ethology and psychoanalysis; Hard sciences, psychoanalysis and the; *Freud, the Secret Passion*; Goethe and psychoanalysis; *Hamlet and Oedipus*; *History and psychoanalysis*; *Imago, Zeitschrift für die Anwendung der Psychoanalyse auf die Geisteswissenschaften*; Law and psychoanalysis; *Leonardo da Vinci and a Memory of his Childhood*; Linguistics and psychoanalysis; Literary and artistic creation; Literature and psychoanalysis; Moses and Monotheism; “The Moses of Michelangelo”; *Myth of the Birth of the Hero, The*; Mythology and psychoanalysis; Pedagogy and psychoanalysis; *Psyché, revue internationale de psychanalyse et des sciences de l’homme*; *Psychoanalysis of Fire, The*; *Psychoanalytic Bewegung, Die*; Psychobiography; Psychohistory; Psychology and psychoanalysis; Racism, anti-Semitism, and psychoanalysis; Sartre and psychoanalysis; Schiller and psychoanalysis; “Seventeenth-Century Demonological Neurosis, A”; Shakespeare and psychoanalysis; Sociology

and psychoanalysis, sociopsychology; Spinoza and psychoanalysis; Structuralism and psychoanalysis; Surrealism and psychoanalysis; *The Life and Works of Edgar Allen Poe*; *Thomas Woodrow Wilson, Twenty-Eighth President of the United States*; *Totem and Taboo*; Training of the psychoanalyst; Visual arts and psychoanalysis.

### Bibliography

Freud, Sigmund. (1887–1904). The complete letters of Sigmund Freud to Wilhelm Fliess, 1887–1904, Ed. and Trans. Jeffrey Moussaieff Masson. Cambridge, Mass, and London: The Belknap Press, 1985.

———. (1905c). Jokes and their relation to the unconscious. *SE*, 8.

———. (1906c). Psycho-analysis and the establishment of the facts in legal proceedings. *SE*, 9: 99–114.

———. (1907a [1906]). Delusions and dreams in Jensen’s “Gradiva.” *SE*, 9: 1–95.

———. (1907b). Obsessive actions and religious practices. *SE*, 9: 117–127.

———, (1908e [1907]). “Creative writers and day-dreaming.” *SE*, 9: 143–153.

———. (1910c). Leonardo da Vinci and a memory of his childhood. *SE*, 11: 59–137.

———. (1912–1913). Totem and taboo. *SE*, 13: ix–161.

———. (1913j). The claims of psycho-analysis to scientific interest. *SE*, 13: 163–190.

———. (1914b). The Moses of Michelangelo. *SE*, 13: 209–236.

———. (1921c). Group psychology and the analysis of the ego. *SE*, 18: 67–143.

———. (1926e). The question of lay analysis. *SE*, 20: 179–250.

———. (1932a [1931]). The acquisition and control of fire. *SE*, 22: 183–193.

———. (1939a [1937–1939]). Moses and monotheism: Three essays. *SE*, 23: 1–137.

———. (1950a). Extracts from the Fliess papers. *SE*, 1: 173–280.

Nunberg, Hermann and Federn, Ernst. (1962–1975). *Minutes of the Vienna Psychoanalytic Society* (December 4, 1907 session). New York: International University Press.

### Further Reading

Baudry, Francis. (1984). Essay on method in applied psychoanalysis. *Psychoanalytic Quarterly*, 53, 551–581.



Esman, Aaron. (1998). What is "applied" in "applied" psychoanalysis?. *International Journal of Psychoanalysis*, 79, 741–756.

Gehrie, M.J. (1992). Panel: Methodology of applied psychoanalysis: key issues. *Journal of the American Psychoanalytic Association*, 40, 239–244.

## APPRENTI-HISTORIEN ET LE MAÎTRE-SORCIER (L'-) [THE APPRENTICE HISTORIAN AND THE MASTER SORCERER]

This book's title and subtitle indicate its essential argument. The *I* is the apprentice historian, the psychological space in which identifications or delusional statements are worked out. According to Aulagnier, two questions have inspired her writings, including this book: the function of the *I* as the builder of its own libidinal history; and the relationship between this *I* and the analytic approach, where the concept of "the repressed" is of central importance.

The master sorcerer is another name for the id, for the psychological place where primal and primary processes write a story without words. In some cases, the subject may experience the "telescoping" of an event, a fantasy, and an identification in such a way that the subject is "stuck with" an identification which he is unable to assume, and yet finds it impossible to repress the fantasy. The task of analysis is to seek out the event that marked the infantile psyche, to bring to light how the irruption of affect contributed to fixing the identification in the subject's mind and worked to impede repression. The *I* can then replace this lived/lost moment with a history of the identification that makes sense of the subject's present life and makes an investment in his future possible.

The first part of Aulagnier's book presents the cases of Philippe and Odette, focusing on their relationships to time. Philippe is a young, delusional, psychotic patient who was treated by Aulagnier, initially during his hospitalization and later in her home, with the idea of undertaking an analytic treatment. Odette is a woman of about forty who elected to undergo analysis (which lasted five years) to help her in her struggle against what she called "dehumanization crises."

Aulagnier presents four versions of Philippe's history: that of Philippe himself, which embodies a delusional causality that brings about "temporal

indifferentiation" and seeks to exculpate his parents; that of the parents, who deny the role they have played in Philippe's life; the version that Aulagnier develops based on the preceding two histories, and on her own suspended theoretical attention; and, finally, the history that evolves within the therapeutic relationship.

Behind the claim of Philippe and his mother, that he "had a wonderful childhood," the analyst clearly discerns the annihilation of a birth. When the therapist suggests that the future is not decided in advance, Philippe responds: "I can't tell the difference between the past and the future. I just don't understand all these dichotomies: past/present, life/death, present/future." Aulagnier believes that in trying decathect her child, the mother has "roboticized" her relationship with him. This is reflected in the leitmotiv of Philippe's delusions: "We are all robots." He has been forbidden, he says, to see his birth. This evokes the prohibition against conceptualizing the mother's desire with regard to that birth. "My father has always been a brother to me," says Philippe. In other words, the paternal function has always been a blank in his history.

The act of eating a San Pedro cactus (*Trichocereus pachanoi*), which marks Philippe's entry into a delusional episode, causes him to meet "the unspeakable." His fantasy is to incorporate "a power close to that of God," but this idea opens the way to a characteristic primal metabolization. He acts out a pictogram: He incorporates and "autolyzes" the stone maternal breast, giver of indistinguishable "life-death"; "his bones and his thoughts" disintegrate, and he self-destructs and destroys the forbidden core that is the cactus/breast. The autolysis actualizes the decathexis that will satisfy both his mother's desire, and his own.

Odette, for her part, substitutes "bodily perceptions" for what she should have borrowed from her mother's discourse to construct the first paragraphs of her history. For lack of an ear capable of hearing her mother's words, her *I* was unable to metabolize into ideational representations those representatives of the suffering body that the psyche then metabolized instead into pictograms and fantasies. Her delusional causality is an attempt to fill the void created by the discourse of the spokesperson. To reconstruct her history and account for the events that have marked her, Odette invokes a single causal factor, "the abjection of the father"—a father whose powers of maleficent desire she idealizes. She then constructs an analytic

theory for herself, apparently “the equivalent of a split-up delusional theory” that is compatible with the discourse of her environment.

In the second part of her book, Aulagnier proposes a theoretical outline of the process of identification. She expands and refines the concept of potentiality as elaborated in her earlier works. While psychotic potentiality is characterized by the conflict between the “Identifying *I*” and the “Identified *I*,” neurotic potentiality involves the relationship between the *I* and its ideals; polymorphous potentiality, when it becomes manifest, leads to symptoms such as love relations or alienating relations, certain forms of somatization, and the like. In this theoretical scheme, T0 corresponds to the birth of the infant, T1 to the emergence of the *I*, and T2 to the conclusive moment when the *I* makes a compromise with reality; this compromise determines the type of potentiality. Potentiality is thus a specific organization that under certain circumstances moves from the potential to the manifest.

Faced by an idea that is “unthinkable and impossible to take on,” and that is evoked by a particular book, Philippe eats the cactus and plunges into a delusional state. Similarly, the revelation of “the magic of analytic knowledge about desire” confronts Odette with an unbearable discovery, the analyst becoming for her an idealized, all-powerful mother. Aulagnier uses the expression “encounter effect” to refer to this type of catalyzing cause that prompts a conflict of identification to pass from the potential to the manifest state.

By way of conclusion, Aulagnier shows how George Orwell’s fictional world in *1984* prefigures her theories of repression and of the process of identification. What Orwell calls “doublethink” is meant to produce a kind of repression within the subject that destroys ideas, consuming them utterly. The objective is to strip the *I* of all confidence in its own thinking. The subject is alienated, for he has internalized the mechanism of repression, but it is Big Brother who decides what the repressed object is. This mutilation serves to provide an idealized figure for repression in the psychotic patient: its function is to prevent the revealing of non-repressed elements active in the mother’s psyche. It thus serves an entity that is external to the subject, whereas in neurosis repression is imposed by the *I*s own thinking. The neurotic forbids him- or herself to desire the forbidden, but the psychotic suffers an external prohibition on the thinking of non-repressed

thoughts. The *I*s power of thinking is inhibited in neurosis, whereas in psychosis it is damaged.

In short, Aulagnier’s hypothesis of a ternary system of representational activity, and the notion of potentiality, profoundly transform and reinvigorate the Freudian understanding of possible mental organizations.

GHYSLAIN CHARRON

See also: Aulagnier-Spairani, Piera; Autohistorization; *I*; Identificatory project; Schizophrenia.

### Source Citation

Aulagnier, Piera. (1984). *L’Apprenti-historien et le Maître-sorcier. Du discours identifiant au discours délirant*. (The apprentice historian and the master sorcerer: From the discourse of identification to the discourse of delusion). Paris: Presses Universitaires de France.

### Bibliography

- Aulagnier, Piera. (2001). *The violence of interpretation: From pictogram to statement*. (Alan Sheridan, Trans.). East Sussex, Philadelphia: Brunner/Routledge. (Original work published 1975)
- . (1979). *Les destins du plaisir. Aliénation, amour, passion*. Paris: Presses Universitaires de France.

---

## ARCHAIC

Archaic is the term used in psychoanalysis to refer to an aspect of the psyche that was organized in the distant past and which contrasts with a new or more evolved organization. The term is used in two specific senses. For Freud the term served essentially to refer to a phylogenetic heritage that involved a way of thinking (1933a [1932]), the requirement of a superego (1923b), or an anxiety associated directly with a prehistoric reality. Freud’s theoretical advances did not affect the nature of the archaic understood in this sense. For Melanie Klein the archaic increasingly refers to that which is not reworked by the development of the depressive position, becoming a synonym of sorts for the pregenital.

These two meanings of the archaic do not always intersect. Freud saw in our phylogenetic heritage something underlying the id, a kind of strata of the psyche whose influence on the remainder of the psyche

was only partial or nonexistent. Through the superego, the ego draws on the experiences of the past stored in the id (1923b). But as far as the magical functions of thinking were concerned, Freud considered the resurgence of an ancient mode of communication such as telepathy, which operated in communities of insects and which can still be actualized in crowds (1933a [1932]). One form of “archaic” thinking, Freud claimed, can still be found in dreams, specifically their symbolism. He also associated a number of infantile desires, including oedipal desires, with a “phylogenetic heritage.” In 1925 Freud noted that the horror of incest and the reality of castration imposed by a leader on his rivals date back to prehistoric times (1925j).

This concept of the archaic is not found in Melanie Klein, for whom the term was far more important than it was for Freud. For Klein the term is always associated with ontogenesis. As Klein’s work reached its maturity, the term came to refer to the anxieties and defenses that crystallized during the formation of the paranoid–schizoid position (1946). The archaic is therefore contrasted with what it is not: the binding associated with the constitution of the depressive position.

What place can be given to the archaic within a conception of psychic life in which everything is a reworking of something else? Doesn’t the activity of deferred action bar access to those so-called archaic strata of the psyche? This brings up the question of the association between the archaic and the actual or present. André Green (1982) situates the problem of the observation of the archaic within this context. This observation can only be illusory because the archaic always appears to us in a transformed state. Whether or not this involves regression, “what is brought to the surface is not the faithful record of a prehistory,” wrote Green. Putting aside the wish to lift the veil on certain occasions, as Freud suggested with his metaphor of archeological excavations that would allow us to discover buried strata of psychic life, wouldn’t it be possible to assign to the archaic an influence ranging from what is most proximate to what is untouchable by definition, for in order to reach it we would have to return to the zero point of time and space, to what is most distant? This would revitalize the interest in direct observation of the infant, which is currently burdened with the reputation of being an observation of the archaic.

Jean-Michel Petot (1982), in his study of the archaic in the work of Melanie Klein, warns of the confusion between the “deep” and the archaic. For regressing to an archaic state that would otherwise need to be addressed in actuality is equivalent to creating a field of psychic depth that only the work of mourning associated with the depressive position can be used to bind and, consequently, put in perspective. In this sense the archaic could be said to be contemporaneous with temporal creation itself.

CLÉOPÂTRE ATHANASSIOU-POPESCO

*See also:* Archaic mother; Idealizing transference; Identification; Myth of origins; Nonverbal communication; Operational thinking; *Phylogenetic Fantasy, A: Overview of the Transference Neuroses*; Pictogram; Prehistory; Primal repression; Primitive; Projection and “participation mystique” (analytic psychology); Self-object; Telepathy; *Totem and Taboo*.

### Bibliography

- Freud, Sigmund. (1923b). The ego and the id. *SE*, 19: 12–59.
- . (1933a [1932]). New introductory lectures on psycho-analysis. *SE*, 22: 5–182.
- Green, André. (1982). Après-coup, l’archaïque. *Nouvelle revue de psychanalyse*. 26, 197.
- Klein, Melanie. (1975). Notes on Some Schizoid Mechanisms. In *The writings of Melanie Klein* (Vol. III, 1946–1963, pp. 1–24). London: Hogarth Press, (Reprinted from *International Journal of Psycho-Analysis* 27 (1975), 99–110.)
- Petot, Jean-Michel. (1982). L’archaïque et le profond dans la pensée de Melanie Klein. *Nouvelle Revue de psychanalyse* 26, pp. 253–272.

## ARCHAIC MOTHER

In the Kleinian constellation over which she presides, the archaic mother is the fantasy mother of the first few months of the infant’s life—the paranoid-schizoid phase. Omnipotent and phallic, she fulfills and frustrates in equally radical measure. She is the key figure in the early stages of the Oedipus complex, and her breast, an object split into a good, nourishing breast and a bad persecutory one, is her generic attribute. It is the target of the ambivalent libidinal and sadistic oral drives of the infant in search of unlimited satisfaction, a satisfaction that, inevitably, will never be achieved.

Beyond such epistemological considerations, the idea of the archaic mother points up a persistent psychoanalytical paradox: the fact that we mourn for origins that are inaccessible yet somehow open to retroactive attempts to reveal them. This figure embodies an archaism with the extraordinary ability to “conjure up the beginning while simultaneously revealing its absence” (Assoun, 1982). The primal mother escapes our grasp yet holds us in thrall.

The notion of the archaic is a semantic point of convergence for several Freudian concepts. It is closely related, for one thing, to the “primal”—to all those terms in Freud’s writings that begin with the prefix “ur-”: *Urszene* (the primal scene), *Urphantasien* (primal fantasy), *Urverdrängung* (primal repression), *Urvater* (primal father). And it is akin to the stratigraphical and archaeological metaphors of which Freud was so fond.

Melanie Klein used the adjective “archaic” only once, but made frequent use of “früh” or “early” (Petot, 1982). The idea of the archaic mother was introduced in connection with Klein’s theses on the early stages of the Oedipus complex in boys and girls (1928). Apropos of the early oral stage of the oedipal conflict, Klein described a “paranoid-schizoid position” characterized by the relationship to part-objects, by the splitting of the ego (an ego lacking in maturity) and of the object, by persecutory anxiety, and by schizoid mechanisms. The breast of the archaic mother was a structuring factor here. Frustrated in their attempts to attain that breast, both girls and boys were prompted to abandon the quest and embrace the wish for oral satisfaction by means of the father’s penis. Introjection of the good and bad breast of the good and bad mother was thus replaced by introjection of the good and bad penis of the good and bad father. The parents became the first models not only for internal protective and helpful figures but also for internal vengeful and persecutory ones; these first identifications by the ego constituted the foundations of the superego. Some of the superego’s most important traits, both its loving/protective and its destructive/devouring sides, were derived from the earliest identifications with the mother.

Klein’s followers developed these ideas, notably that of projective identification in infants (Bion, 1962; Meltzer, 1992); their exploration of childhood psychoses

went in the same direction (Tustin, 1972; Meltzer, 1975).

The archaic mother is part of a long mythological tradition stemming from the fecund and savage Earth Mother of ancient Greek cosmogony. In psychoanalysis the theme is discernible, for example, in the sea “abandoned in primeval times” of Ferenczi’s *Thalassa* (1924, p. 52), in Freud’s phylogenetic explanation of primal fantasies (1915f, p. 269 and n.), or in the “biological bedrock” of the “repudiation of femininity” (Freud, 1937c, pp. 250–52).

If the “archaic” is forever generating meaning in the unconscious without ever manifesting itself as a perceptible cause, it is the task of metapsychological speculation to offer an account of this phenomenon. The aforementioned psychoanalytical “mythologies” may indeed be said to respond to an “epistemic imperative” (Assoun, 1982). At the same time, however, any psychoanalytical view of the archaic, which is inseparable from the discussion of “deferred action” (q.v.), can achieve legitimacy only by eschewing the naïvety of the Freudian archaeological metaphor: the “archaic mother” of an excavated past does not amount to a restoration of the original.

Recently the analysis of borderline conditions has highlighted the notion of an analyst who does not *represent* the mother but instead *is* the omnipotent mother. This figure is the object of a transference that is “both archaic and a defense against the archaic” (Green, 1982).

At present, clinical work on the psychoanalysis of origins has an important part to play in the study of parenthood. In the contexts of infertility, perinatal psychopathology, or transgenerational mental transmission, the consideration of the structural outcome of parental conflict with the archaic (grand-) mother has given this concept a new lease on life (Bydlowski, 1997).

SYLVAIN MISSONNIER

*See also:* Breast, good/bad object; Oedipus complex, early; Paranoid-schizoid position; Real, Imaginary, and Symbolic father; “Vagina dentata,” fantasy of.

### **Bibliography**

Assoun, Paul Laurent. (1982). L’archaïque chez Freud: entre Logos et Anankè. *Nouvell revue de psychanalyse*, 26, 11–44.

- Bydlowski, Monique. (1997). *La dette de vie : itinéraire psychanalytique de la maternité*. Paris: Presses Universitaires de France.
- Bion, Wilfred R. (1967). A theory of thinking. In *Second thoughts*. London: Heinemann. (Reprinted from *International Journal of Psycho-Analysis*, 43, (1962) 4–5.)
- Ferenczi, Sándor. (1968). *Thalassa: A theory of genitality*. (Henry Alden Bunker, Trans.). New York: W. W. Norton. (Original work published 1924)
- Freud, Sigmund. (1915f). A case of paranoia running counter to the psycho-analytic theory of the disease. *SE*, 14: 261–272.
- . (1937c). Analysis terminable and interminable. *SE*, 23: 209–253.
- Green, André. (1982). Après-coup, l'archaïque. *Nouvelle revue de psychanalyse*, 26, 195–216.
- Klein, Melanie. (1975). Early stages of the Oedipus conflict. In *Love, guilt and reparation and other works, 1921–1945*. London: Hogarth/Institute of Psycho-Analysis. (Reprinted from *International Journal of Psycho-Analysis*, 9, (1928) 167–180.)
- Meltzer, Donald. (1975). Adhesive identification. *Contemporary Psycho-Analysis*, 11, 289–310.
- . (1992). *The claustrum. An investigation of claustrophobic phenomena*. Karnac Books.
- Petot, Jean-Michel. (1982). L'archaïque et le profond dans la pensée de Melanie Klein. *Nouvelle Revue de psychanalyse*, 26.
- Tustin, Frances. (1972). *Autism and childhood psychosis*. London: Science House.

## ARCHEOLOGY, THE METAPHOR OF

Archeology, the study of artifacts from the past, is relevant to psychoanalysis in the sense that an analogy can be established between the search for a collective past and the search for an individual past. Freud himself uses the metaphor of archeology in his *Delusions and Dreams in Jensen's "Gradiva"* (1907a). His description of the structure of hysteria as a building of several dimensions, containing at least three strata ("The Psychotherapy of Hysteria" in *Studies on Hysteria*, 1895d), even though it refers to an archival case, also evokes the work of the archeologist: The order of discovery is reversed, with the most primal matter being the most deeply buried ("Saxa loquuntur," 1896c).

Freud was very interested in archeological research (Schliemann's excavation of Troy, for example) and

the collected artifacts, many of which decorated his office and which he frequently showed to his patients (*The Rat Man*, 1909d) as signs of the preservation of traces of a past that had become unconscious. More profoundly, we find that the methods of the archeological dig and those of psychoanalytical investigation have followed a similar evolution, consisting in shifting the focus of interest from a privileged object that will be excavated to a gradual discovery of the terrain (stratigraphic method), through which it is possible to trace the thread of history back to its origins step by step. Interest in these vestiges, which constitute "a history without a text" (André Leroi-Gourhan), intersects the work of reconstruction that takes place during analysis (Freud, 1937c). Similarly, the interest in a missing element (doubt in the dream, foreclosed elements in psychosis) evokes this preservation-through-absence that archeologists experience in what they call "ghost sites" (Mijolla-Mellor, 1993).

The archeological metaphor is present throughout Freud's work (1911f) and underlines the similarity with the work of therapy as well as the differences, especially since the working conditions of the psychoanalyst, and his or her ability to bring back old emotions through transference, are better than those of the archeologist.

SOPHIE DE MIJOLLA-MELLOR

See also: Archaic; Archaic mother; Model; Memories.

### Bibliography

- Bernfeld-Cassirer, Suzanne. (1951, June). Freud and archaeology. *American Imago*, VIII, 107–128.
- Flem, Lydia. (1982). L'archéologie chez Freud : destin d'une passion et d'une métaphore. *Nouvelle revue de psychanalyse*, 26, pp. 71–94
- Freud, Sigmund. (1896c). *The aetiology of hysteria*. *SE*, 3: 186–221
- . (1907a [1906]). Delusions and dreams in Jensen's "Gradiva." *SE*, 9: 1–95.
- . (1909d). Notes upon a case of obsessional neurosis. *SE*, 10: 151–318.
- . (1937c). *Analysis terminable and interminable*. *SE*, 23: 209–253.
- Freud, Sigmund, and Breuer, Josef. (1895d). Studies in hysteria. *SE*, 2: 48–106
- Mijolla-Mellor, Sophie de. (1993). Le "bon droit" du criminel. *Topique*, 52, 141–161.

## ARCHETYPE (ANALYTICAL PSYCHOLOGY)

The scientific hypothesis of the archetype was proposed by Jung as an innate formal element that structures the psyche at its most basic levels. In itself psychoid and therefore anchored in reality beyond the psyche (in “spirit” or nous, the non-biological mind), the archetype is responsible for coordinating and organizing the psyche’s homeostatic balance and its programs for development and maturation. Essentially there is one master archetype, the self, which defines the skeletal form of human wholeness.

The archetype itself is not available directly to experience—only its images and created patterns can become manifest and subject to experience by the psyche. These archetypal images are potentially unlimited in number and variety. They are embedded in the universal patterns of myth, in religious symbols and ideas, and in numinous experiences; they are also often represented in symbolic dreams and in altered states of consciousness. Within the psyche, archetypal images are linked to the (five) instinct groups, giving them direction and potential meaning. Like the archetype, the instincts are psychoid and rooted in reality beyond the psyche itself (in the physiological base of the psyche, the body). Archetypal images and instinctual impulses, united within the psyche, together make up the collective unconscious, the primordial psychosomatic basis of all psychic functioning.

Jung first used the term “archetype” in 1919. This was preceded by several years of speculation on primordial images and impersonal dominants. The implications of the archetypal hypothesis were developed by Jung himself and by his many students over subsequent decades in numerous case studies and investigations of myth, religion, and esoteric practices, especially alchemy. As the field of analytical psychology has grown and developed, the notion of the archetype and the role of archetypal images in psychological functioning and development have assumed a central role and have become the most distinctive feature of this school of psychoanalysis. Archetypal psychology, led by James Hillman, is a later offshoot of analytical psychology.

Jung himself found important connections between archetypal theory and the work of such ethologists as Konrad Lorenz who studied innate patterns of animal behavior and discovered innate releasing mechanisms. There are also parallels to be drawn between archetypal

patterns and the innate mental schemas described in cognitive psychology. Recent findings of innate human patterns in neuropsychiatry and sociobiology also suggest confirmation of the hypothesis of the archetype. Some leading thinkers in analytical psychology have found close similarities between the theory of archetypal images and Kleinian notions of unconscious phantasy.

Criticisms of the archetypal hypothesis have come from many quarters. As an essentialist position, it has drawn fire from social constructionists who argue that human nature is infinitely malleable and defined more importantly by social and material conditions than by innate propensities. It has also drawn criticism from clinicians for whom the personal conflicts and traumas inflicted in childhood define the universe of therapeutic concern. For Jung and his adherents, however, the archetype has been seen as the source of healing and as the guide to potential wholeness of the individual.

MURRAY STEIN

*See also:* Amplification (analytical psychology); Animus-Anima (analytical psychology); Imago; Mother goddess; Numinous (analytical psychology); Self (analytical psychology); Symbolization, process of; Synchronicity (analytical psychology); Transference/counter-transference (analytical psychology).

### Bibliography

- Jung, Carl G. (1935b [1954]). Archetypes of the collective unconscious. *Coll. Works* (Vol. IX, Part I). London: Routledge & Kegan Paul
- Neumann, Erich. (1955). *The great mother: An analysis of the archetype*. London: Routledge.
- Stein, Murray. (1996). *Practicing wholeness*. New York: Continuum.
- Stevens, Anthony. (1982). *Archetypes: A natural history of the self*. London: Routledge.

---

## ARCHIVES DE PSYCHOLOGIE, LES

*Les archives de psychologie* was founded in 1902 by Théodore Flournoy and Édouard Claparède. Though the review was eclectic and devoted itself to all aspects of psychology, principal areas of interest were psychic phenomena, the psychology of normal and abnormal children, and psychopathology.

Théodore Flournoy was then a professor of experimental psychology in the Department of Science at the University of Geneva. He was interested in obscure phenomena disdained by official science: genius, mysticism, metapsychic phenomena. Édouard Claparède, his assistant, had an interest in psychopedagogics.

From the beginning of the century until World War I, the review played a pioneering role in spreading an awareness of psychoanalysis throughout French-speaking countries. Psychoanalytic publications in German were regularly printed and analyzed. Many original articles were directly related to Freudian theory, including the work of Alphonse Maeder, Paul Menzerath, Pierre Bovet (then codirector of the Institut Jean-Jacques Rousseau), Paul Ladame, and Carl Gustav Jung. After Freud and Jung split in 1913, the review refused to take a stance between the two camps.

Upon the death of Théodore Flournoy in 1920, the review obtained the help of Jean Piaget, who reinforced the focus on child psychology and applied psychology. After 1930 the review devoted almost no space to psychoanalysis.

ANNICK OHAYON

See also: Claparède, Édouard; Flournoy, Théodore; Piaget, Jean.

### **Bibliography**

Bovet, Pierre. (1913). Un rêve expliqué. *Archives de psychologie*, 13, 380–383.

Maeder, Alphonse. (1907). Essai d'interprétation de quelques rêves. *Archives de psychologie*, 6, 354–375.

Menzerath, Paul. (1912). Contribution à la psycho-analyse. *Archives de psychologie*, 12, 372–389.

Piaget, Jean. (1923). La pensée symbolique et la pensée de l'enfant. *Archives de psychologie*, 18 (72), 273–304.

---

## **ARGENTINA**

Argentina is unlike other Latin American countries in that its population is in large part the result of the massive European immigration that took place beginning in the late nineteenth century. Between the last decades of that century and with the global economic crisis of 1930, the country experienced increased prosperity. During that interval, the cultural climate was infused with a number of avant-garde intellectual currents.

Psychoanalysis in Argentina can be broken down into five periods: 1) the pre-institutional period, 2) the pioneer period, 3) the institutional period, 4) the crisis of the seventies, and 5) the present.

After 1922, and during the pre-institutional period, Spanish translations of the first volumes of Freud's complete works began to appear in Argentina, although translations in other languages were known. As early as 1910, however, Freud's ideas about infantile sexuality, free association, and psychoanalysis had been presented in Buenos Aires by the Chilean doctor Germán Greve (quoted by Freud in *The History of the Psychoanalytic Movement*) during the International Congress of Medicine and Hygiene, and the Peruvian Honorio Delgado had published articles on psychoanalysis in several prestigious medical journals.

In 1922 Enrique Mouchet, who had been professor of experimental psychology and physiology for two decades in the Department of Philosophy and Literature at the University of Buenos Aires, made psychoanalysis part of his syllabus, although he was critical of it. In 1923 the Spanish doctor Gonzalo Lafora gave a number of talks on psychoanalysis at the school of medicine. In February 1930, two recognized psychiatrists left for Vienna to visit Freud: Gregorio Bermann and Nerio Rojas, who would later publish a report of his meeting in the widely circulated daily *La Nación*. During the thirties, inexpensive editions of Stefan Zweig's biography of Freud were printed, as well as a ten-volume series of popularizations of Freud entitled, *Freud Made Easy*, carelessly edited (pseudonymously) and containing long passages from the Spanish translation of Freud's works.

The journal *Critica* regularly published a column on psychoanalysis devoted to the interpretation of dreams. In 1936 one of the most serious literary reviews in the country, *Sur*, paid homage to Freud; the review *Psicoterapia* also devoted an issue to the founder of psychoanalysis. A group of writers invited Freud to move to Argentina. Jorge Thenon, a self-taught psychoanalyst, received a letter from Freud, to whom he had sent his thesis, "Psicoterapia comparada y psicogénesis" [Comparative Psychotherapy and Psychogenesis], in which Freud encouraged him to continue his work for future publication in an international psychoanalytic review. The letter appeared in *La Semana médica* in 1933.

In 1938 the arrival of the Hungarian psychologist Béla Székely in Argentina helped to spread psychoanalytic

ideas along with the use of tests, especially Rorschach tests. During that same decade, Enrique Pichon-Rivière and Arnaldo Rascovsky discovered Freud's work; they devoted themselves to its study and its clinical application. Pichon-Rivière formed a working group with Arminda and Frederico Aberastury; Rascovsky, with his wife Matilde Wencelblat, Luisa Gambier (later Luisa Alvarez de Toledo), Simon Wencelblat, Teodoro Shlossberg, Flora Scolni, Alberto Tallaferro, and Guillermo Ferrari Hardoy.

In 1939, two psychoanalysts from Europe, the Argentine Celes Cárcamo, member of the Paris Psychoanalytic Society, and the Spaniard Angel Garma, member of the German Psychoanalytic Association, joined Rascovsky's and Pichon-Rivière's groups. Celes Cárcamo had been a friend of Pichon-Rivière for years. Angel Garma, who had wanted to leave Spain for Argentina, had met Cárcamo in Paris. A decision was made to found a psychoanalytic association as soon as a sufficient number of analysts could be brought together. Luisa Alvarez de Toledo, Luis Rascovsky, Guillermo Ferrari Hardoy, and Alberto Tallaferro began analysis with Cárcamo, while Arnaldo Rascovsky, Enrique Pichon-Rivière, and Arminda Aberastury started with Garma. The patients who were analyzed by Cárcamo were supervised by Garma and vice versa.

On December 15, 1942, Cárcamo, Garma, Ferrari Hardoy, Pichon-Rivière, Rascovsky, and Marie Langer founded the Asociación Psicoanalítica Argentina (APA), which marked the debut of the institutional period. Marie Glas de Langer, who had sought refuge in Uruguay in 1938, settled in Buenos Aires in 1942. Analyzed by Richard Sterba, she had been trained at the Vienna Institute of Psychoanalysis but, to complete her clinical work, she underwent a control analysis with Celes Cárcamo. Shortly after it was founded, the association received the provisional approval of Ernest Jones, then president of the International Psychoanalytic Association (IPA). The APA was recognized as a member society of the IPA at the Zurich Congress, in August 1949.

In July 1943, the first issue of the *Revista de psicoanálisis* appeared, and that same year the publisher Biblioteca de Psicoanálisis went into operation. This began a process of rapid expansion of the discipline both inside and outside Argentina. Therapists from throughout Latin America arrived eager for training, there were many foreign visitors, and Argentinian analysts traveled to present their work in other

countries throughout the Americas and Europe. In 1953, the association had more than 68 members in all categories.

Angel Garma, who was analyzed by Theodor Reik and undertook his control analysis with Otto Fenichel, had an interest in a number of fields and in all of them he left his personal mark. He discussed Freud's theory of hallucinations in 1931, generalized the hypothesis of the traumatic genesis of dreams, and promoted psychoanalytic research and treatment in the field of psychosomatic disturbances. Celes Cárcamo was analyzed by Paul Schiff and had his control analysis with Rudolph Loewenstein and Charles Odier. He was interested in philosophy, religion, art, and especially therapy, and through his personal prestige and integrity helped introduce psychoanalysis to different social and professional milieus. During his early years, his writings primarily focused on psychoanalytic technique and psychosomatics.

The analysis of psychosis became a focus of interest through the impetus of Enrique Pichon-Rivière, along with Arnaldo Rascovsky's research on mania. Pichon-Rivière emphasized the "single illness" theory and proposed a psychopathology that centered on a central pathogenic kernel or "fundamental depressive situation." Rascovsky, in his work on fetal psychism, introduced the hypothesis of a prenatal maniacal position, prior to the introduction of the paranoid-schizoid position by Melanie Klein.

Arminda Aberastury and Elisabeth Goode de Garma specialized in the psychoanalysis of children and adolescents, basing their work on the theoretical contributions of Melanie Klein. Increasing demand and theoretical interest in this type of therapy helped stimulate the growth of group psychoanalysis. The work of Marie Langer, León Grinberg, and Emilio Rodrigué stands out in this field. The personality and the ideas of these pioneers affected the tenor of their theoretical work. There was a strong Freudian influence, of course, but Otto Fenichel, Hermann Nunberg, Wilhelm Reich, Paul Federn, and Melanie Klein were read as well.

Other important work was done by Marie Langer on femininity and by Luisa Alvarez de Toledo in her research on "association" and "interpretation," which contributed to the interest in language, a subject later taken up by David Liberman. Heinrich Racker made significant contributions to the study of the



instrumental value of countertransference (concomitant with the work of Paula Heimann in Great Britain).

The tentative return to democracy in 1958, which coincided with one of the most brilliant moments in the contemporary history of the University of Buenos Aires, provided a favorable framework for the activity of new generations of psychoanalysts. It was during this period that there arose the personalities and ideas that would, to a large extent, define the identity of what came to be known as the “Argentinian school.” Alongside the work of Rascovsky, Garma, Pichon-Rivière, and Racker, the names of León and Rebeca Grinberg, Willy and Madeleine Baranger, Jorge Mom, Jorge García Badaracco, Mauricio Abadi, Edgardo Rolla, Fidias Cesio, José Bleger, David Liberman, Joel Zac, Horacio Etchegoyen, Salomón Resnik, Luis Chiozza, Isidoro Berenstein, and many others gained local and international recognition.

The dominant theoretical trends revolved around English authors, primarily Melanie Klein and her closest collaborators: Paula Heimann, Hanna Segal, Susan Isaacs, and later Donald Meltzer, Wilfred Bion, and Herbert Rosenfeld. When Klein’s influence reached its peak, there were four dominant trends: dogmatic Kleinians, critical Kleinians (Baranger), those who deepened and extended her work (Grinberg, Bleger, Liberman, Etchegoyen, Zac), and those who responded to her theories with a refreshing (non-Lacanian) return to Freud.

During this period, the first non-IPA schools of psychoanalysis appeared, founded by members of the APA, to meet the growing demand for training and the limited opportunities for admission provided by the Association. Another important event that occurred at this time was the introduction of psychoanalysis in hospitals throughout Argentina. Also, during this ten-year period, a school of psychology was created in Buenos Aires. Psychoanalysis played a major role in the curriculum and a number of qualified psychoanalysts were on the staff. The school produced a large number of clinical psychologists. After 1986 they were able to join the APA once it removed the restriction that required practitioners of psychotherapy to be medical doctors.

The seventies were a period of increased tension. Changes around the world had repercussions in the country generally and on the psychoanalytic movement in particular. Passionate debates within the psychoanalytic community prevented any kind of consistent intellectual progress. During this confused

period, a number of well-known analysts (Marie Langer, Diego and Gilou García Reynoso, among others) left the APA and founded the Plataforma and Documento movements. Other forms of psychotherapy competed for the market of available patients, whose numbers continued to increase rapidly. This was somewhat muted by the economic inflation and the increasing social and individual malaise. Antagonisms among psychoanalysts concerning institutional attitudes and psychoanalytic training grew steadily, culminating in the schism that would divide the Argentine Psychoanalytic Association and give birth, in 1977, to the Asociación Psicoanalítica de Buenos Aires (APDEBA), officially recognized the same year by the IPA during its Congress in Jerusalem.

It was at this time that Jacques Lacan’s ideas entered the sphere of Argentinian psychoanalysis. These ideas rallied legions of partisans, not only because of their inherent interest but because of the anti-institutional orientation that Lacan embodied within the range of the then current warring ideological positions. Lacan’s followers were soon clamoring for positions in hospitals, universities, and on the pages of the leading reviews. The particular language used by Lacanians made it difficult to confront them or even exchange ideas on the basis of an alternate terminology, which effectively curtailed the traditional intellectual pluralism that had been the norm within psychoanalytic organizations.

At the time there were five psychoanalytic institutions affiliated with the IPA: two in Buenos Aires (APA and APDEBA) and three in the cities of Mendoza, Córdoba, and Rosario. Unlike the previous periods, psychoanalysis now had to struggle for its identity and avoid being diluted in a complex and confusing “world of psych.” A number of non-IPA teaching facilities were established, but the level of teaching was inconsistent. In spite of the changing, and unfavorable, cultural context, which contrasted sharply with the climate of the previous periods, the output of the majority of psychoanalysts was considerable, the local associations remained consistently productive, with an abundance of publications of high quality, and Lacanian organizations were highly active, demonstrating the persistent vitality of the discipline in the country.

Psychoanalysis in Argentina was influenced by global trends. Willy Baranger, initially influenced by the ideas of Enrique Pichon-Rivière, engaged in a critical examination of key concepts in psychoanalysis, from Melanie

Klein to Jacques Lacan. Because of the lucidity of his approach, Baranger's work became a key focus of psychoanalytic thought in Argentina, and has remained valid for the second generation of practitioners.

An indigenous line of thought focused on method soon developed in Argentina. It was based on the technical work of Heinrich Racker and its greatest representative was Horacio Etchegoyen, who perfected it through his many innovative contributions to the theory of psychoanalytic technique and his marked interest in the epistemological aspects of the discipline. Another local current came into prominence during the eighties and favored a diversification of practice in the psychoanalytic approach to group, family, and couples therapy. There was considerable interest in the social aspects of psychoanalysis, which led to the development of more committed positions among psychoanalysts and a psychoanalytic approach to social phenomena of violence. Developments in the field of psychosis, the diversification of applied psychoanalysis, and work in the field of psychosomatics reflect the range of contributions of contemporary psychoanalysis in Argentina.

ROBERTO DORIA-MEDINA JR.  
SAMUEL ARBISER  
MOISÉS KIJAK

### **Bibliography**

- Aberastury, Arminda, et al. (1967). *Historia enseñanza y ejercicio legal del psicoanálisis*. Buenos Aires: Omeba.
- Cucurullo, Antonio, et al. (1982). La psychanalyse en Argentine. In Roland Jaccard (ed.), *Histoire de la psychanalyse*, vol. II: 395–444. Paris: Hachette.
- Mom, Jorge (1982). *Asociación psicoanalítica argentina 1942–1982*. Buenos Aires: A.P.A.
- Vezzetti, Hugo (1996). *Aventuras de Freud en el país de los argentinos*. Buenos Aires: Paidós.
- Wender, Leonardo, et al. (1992). Argentina. In Peter Kutter (Ed.), *Psychoanalysis international, a guide to psychoanalysis throughout the world* (vol. 2). Stuttgart-Bad Cannstatt: Frommann-Holzboog.

### **ARLOW, JACOB (1912–2004)**

Jacob A. Arlow, American psychiatrist and psychoanalyst, was born September 3, 1912 in New York, where he died May 21, 2004.

The youngest of three children, he was raised in modest circumstances in Brooklyn, New York. Subject to frequent childhood illnesses, he spent much time in reading and reflection. With his encyclopedic knowledge and superb intellectual endowment, he found his way to Freud's writings in his adolescence. Graduating from New York University at the age of twenty, he then earned his M.D., also from NYU. While in the United States Public Health Service, training in psychiatry, he planned his study of psychoanalysis at the New York Psychoanalytic Institute. He was appointed a training and supervising analyst soon after his graduation in 1947. In 1960 he was elected president of the American Psychoanalytic Association and was elected Chairman of its Board of Professional Standards from 1967–1969. From 1963 to 1967 he served as treasurer of the International Psychoanalytic Association.

Jacob Arlow's teaching, presentations, lectures, seminars, and writing illuminated the different areas of psychoanalytic theory, technique, and applied analysis. His teaching was known for its clarity, consistency, and the force of his ideas. Emphasizing methodology and the importance of evidence, he advocated the objective marshaling and organizing of data after careful listening and contemplation. Arlow emphasized the close correlation of observation and inference with critical evaluation. His analytic ideas were lucidly expressed with attention to sound and silence, with apt metaphor. He regarded metaphor as central to clinical psychoanalysis. Arlow had an intense interest in the arts and humanities, and published many relevant psychoanalytic papers. Well versed in Jewish history, he was fluent in biblical Hebrew, a student of the Bible and its psychoanalytic interpretation.

The scope and depth Arlow achieved in his work are remarkable. He was the author of more than two hundred papers and a classic volume on structural theory, co-authored with Dr. Charles Brenner. He is regarded as one of the architects of American ego psychology, extending the concept of ego functions far beyond defense as originally formulated. Affects and moods were not simple drive derivatives, but had important regulatory functions, already indicated by Freud in the concept of signal anxiety.

In his later work he demonstrated a growing interest in psychoanalytic developmental theory. He contributed importantly to the psychoanalytic concept of unconscious fantasy and its clinical application. For Arlow unconscious fantasy was a compromise

formation, which encompassed elements of both the internal world and external reality, including identifications with external objects. Unconscious fantasies could undergo alteration during different developmental phases, which would then effect changes in symptoms and character. Transference and countertransference could best be understood in terms of their underlying unconscious fantasies. Arlow's papers included significant expositions of myth and the interrelationship of myth and culture. Myth was described as not only related to infantile unconscious fantasy, but also as a facilitator of the child's fitting into the particular cultural society in which he was reared.

Arlow's original contributions have left a permanent influence and in many respects transformed North American psychoanalytic theory and technique.

HAROLD P. BLUM

*See also:* Allergy; *Journal of the American Psychoanalytic Association*; Ego psychology; New York Psychoanalytic Institute; Silence; Therapeutic alliance.

### **Bibliography**

Arlow, Jacob A. (1961). Ego psychology and the study of mythology. *Journal of the American Psychoanalytic Association* 9, 371–393.

———. (1962). Conflict, regression and symptom formation. *International Journal of Psycho-Analysis* 44, 12–22.

———. (1969). Unconscious fantasy and disturbances of conscious experience. *Psychoanalytic Quarterly* 38, 1–17.

———. (1979). The genesis of interpretation. *Journal of the American Psychoanalytic Association*, Supplement, 27, 193–206.

Arlow, Jacob A., and Brenner, Charles (1964). *Psychoanalytic concepts and the structural theory*. New York: International Universities Press.

---

## **ARMAND TROUSSEAU CHILDREN'S HOSPITAL**

The Armand Trousseau Children's Hospital is a symbolic landmark in the treatment of suffering children, whether from physical or psychical problems. Since the late 1960s, Trousseau has witnessed the birth and development of a massive movement to humanize hospital treatment for children. It is arguable that the necessity for parental presence close to hospitalized

children was first recognized in the wake of the events of May 1968. We must not forget that prior to this time, young children were systematically strapped into their beds except for very limited visiting hours for the family. Generally speaking, very little attention was paid to the consequences of physical suffering, separation from the family, and the illness itself. The work of the pediatricians, psychologists and psychiatrists in Trousseau hospital—accompanied by important though less global actions in other French hospitals—introduced radical reforms in the way children were received, the quality of their stay and most of all in terms of consideration for hospitalized children.

It was indeed in this hospital that the humanization of pediatrics first blossomed and flourished, before being given concrete form in official decrees (*Bulletin officiel*, 1983, "Child hospitalization, Ministry for Social Affairs and National Solidarity, decree no. 83–24 of August 1, 1983", special issue no. 83/89b). Actions such as no longer strapping children into their beds, opening hospital sections up to parents, designating the first rooms for mothers, training maternity staff to inform and support parents after the birth of a handicapped child, the prevention of maltreatment, and the creation of a school inside the hospital all served to transform treatment.

Simultaneously, this collaboration between pediatricians, psychologists and psychiatrists gave rise to the notion of liaison psychiatry and thus the presence in almost every pediatrics department of psychologists and child psychiatrists. The metapsychological markers introduced by psychoanalysts contributed in a specific and important manner to defining this clinical field.

It is no accident that Françoise Marelle Dolto conducted a psychotherapy consultation unit for trainee analysts at Trousseau from 1940 to 1978. Her presence left a deep and lasting mark, although we must bear in mind—and this is by no means the least of the paradoxes—that this consultation unit was never a part of the psychiatric department: the premises were simply lent to her and she was never paid by the hospital. All of the movements initiated at Trousseau to improve the conditions governing child hospitalization and treatment link up, at least symbolically, with her combat for the recognition of children as subjects in their own existence.

FRÉDÉRIQUE JACQUEMAIN

*See also:* Dolto-Marelle, Françoise.

### Bibliography

- Dolto, Françoise. (1989). *Autoportrait d'une psychanalyste*. Paris: Le Seuil.
- Lelong, Marcel, and Lebovici, Serge. (1955). Problèmes psychologiques et psychopathologiques posés par l'enfant à l'hôpital. *Archives françaises de pédiatrie*, XII (2), 349–367.
- Rapoport, Danièle. (1972). Le rôle des psychologues dans les services de pédiatrie. In Henri Pieron, Ed., *Traité de psychologie appliquée* (pp. 149–182). Paris: Presses Universitaires de France.
- Soulé, Michel, and Lebovici, Serge. (2003). La connaissance de l'enfant par la psychanalyse. Paris, Presses Universitaires de France.

---

**ARPAD.** See **Little Arpad the boy pecked by a cock**

---

### ARROGANCE

In the course of psychoanalyzing psychotic patients, Bion came across a series of invariant clinical phenomena that seemed to characterize the psychotic personality. In 1958, he presented the paper “On Arrogance,” in which he noted that the psychotic patients he was analyzing seemed to demonstrate a constantly conjoined yet mysteriously dispersed triad of phenomena: *arrogance*, *curiosity*, and *stupidity*. Bion was able to formulate that the root cause of this syndromic cluster of phenomena was ultimately due to a failure on the part of the psychotic patient to have had at his disposal as an infant a mother who was able or willing to tolerate his projective identifications into her. This theme of the unavailability of a receptive mother to tolerate her infant's projective identifications was to be carried through in two successive papers, “Attacks on Linking” and “A Theory of Thinking.” Ultimately, it became the pivotal alteration of Klein's concept of intrapsychic projective identification into intersubjective projective identification and the foundation for Bion's later theories of alpha function and container/contained.

Bion found that, in these patients, the triad of curiosity, stupidity, and arrogance was initiated clinically by the revival in the analysis of the presence of an *obstructive object*, which represented the psychotic infant's projection-rejecting (part-object) mother in addition to her hostility *and* the infant's hostility. As

an internalized hybrid, it becomes a formidable, archaic superego, which attacks the infant's normal curiosity; is arrogant (because of the projective identification of omnipotence); and conveys stupidity because of its hatred of curiosity. Bion states that where the life instincts predominate, pride becomes self-respect, whereas when the death instinct predominates, pride becomes arrogance.

The fact that the triad is mysteriously dispersed, and therefore unsuspected as belonging together, is evidence, according to Bion, that a psychotic disaster had taken place. The analytic process itself, which seeks to learn more, constitutes the stimulus for curiosity. Bion states, “The very act of analyzing the patient makes the analyst an accessory in precipitating regression and turning the analysis itself into a piece of acting out” (Bion, 1967, p. 87). The features that characterize the transference are references to the appearance of the analyst and the analysand's identification with him in terms of being “blind, stupid, suicidal, curious, and arrogant.” (Bion, p. 88). What takes place is a hateful attack by this obstructive superego against the ego, either in the analysand or, by projective identification, in the analyst. Thus, either the analyst and or the analysand are targets of the obstructive object's hateful attacks.

Since the aim of analysis is the pursuit of truth (curiosity), the truth-pursuing analyst is considered to have a capacity to contain the discarded, split-off portions of the analysand's psychotic self, including the obstructive object and its destructive effects. This capacity becomes the target for envious and hateful attacks. In short, as Bion summarizes:

What it was that the object could not stand became clearer . . . where it appeared that in so far as I, as analyst, was insisting on verbal communication . . . I was felt to be directly attacking the patient's methods of communication [i.e., projective identification].

Bion further summarizes that in some patients the denial to the patient of a normal employment of projective identification precipitates a disaster through the destruction of an important link. Inherent in this disaster is the establishment of a primitive superego which denies the use of projective identification.

JAMES S. GROTTSTREIN

*See also:* Alpha function.

### Bibliography

Bion, Wilfred R. (1967). On arrogance. In his *Second thoughts* (pp. 87–88). London: Heineman.

## AS IF PERSONALITY

In 1934, and again in 1942, Helene Deutsch described what she called the “as if” (*als ob*) personality type. She was referring to individuals who leave other people with an impression of inauthenticity, even though they seem to enjoy “normal” relations with those around them and even though they complain of no disorder. They appear perfectly well adjusted, and are even capable of a certain warmth, but in a number of circumstances they betray a lack of emotional depth.

This phenomenon does not correspond to a type of repression but rather to a “real loss of object cathexis. The apparently normal relationship to the world corresponds to a child’s imitativeness and is the expression of identification with the environment, a mimicry which results in an ostensibly good adaptation to the world of reality despite the absence of object cathexis” (1942, p. 304). Their creations are, on observation, “a spasmodic, if skilled, repetition of a prototype without the slightest trace of originality” (p. 303). “Another characteristic of the ‘as if’ personality is that aggressive tendencies are almost completely masked by passivity, lending an air of negative goodness, of mild amiability which, however, is readily convertible to evil” (p. 305).

In the course of psychoanalytic treatment their behavior may seem to indicate excellent cooperation and a certain progress, until the analyst realizes that nothing is actually happening, that the patients have changed nothing in their lives. Although “a strong identification with the analyst can be used as an active and constructive influence” (*ibid.*), these patients often develop a “vocation” to become psychoanalysts themselves.

Deutsch classified such personalities as “depersonalized” and associated them with schizoid-type behavior, insisting that there was a schizoid psychotic core behind their pseudo-normality. They were later classed as “borderline states” presenting “narcissistic disorders” or, according to Heinz Kohut, “disorders of the Self.” Links have also been established between “as if” personalities and the notion of a “false Self” developed by Donald W. Winnicott (1962/1965), or Phyllis Greenacre’s studies of “the imposter” (1958). Masud Khan related the etiology of “as if” personalities to the

failure of the superego or the absence of a personal ideal ego, suggesting that although these subjects give the impression of being psychopathic or immoral “they have a very highly organized ego-ideal and all their attempts are to approximate to its demands” (1960, p. 435).

In any event, Deutsch’s initial description corresponds to a reality that continues to be confirmed in clinical experience as in everyday life.

ALAIN DE MIJOLLA

See also: Autistic capsule/nucleus; Blank/nondelusional psychoses; Depersonalization; Deutsch-Rosenbach, Helene; Imposter; Lie; Normality.

### Bibliography

Deutsch, Helene. (1934). Über einen Typus der Pseudoaffektivität (“Als ob”). *Internationale Zeitschrift für Psychoanalyse*, 20.

———. (1942). Some forms of emotional disturbance and their relationship to schizophrenia. *Psychoanalytic Quarterly*, 11.

Greenacre, Phyllis. (1958). The impostor. *Psychoanalytic Quarterly*, 27 (3), 359–382.

Khan, Masud. (1960). Clinical aspects of the schizoid personality: Affects and technique. *International Journal of Psycho-Analysis*, 41, 430–437.

Winnicott, Donald W. (1965). Ego distortion in terms of true and false Self. In *The maturational processes and the facilitating environment* (pp. 140–152). London: Hogarth and the Institute for Psycho-Analysis. (Original work published 1962)

## ASSOCIATION PSYCHANALYTIQUE DE FRANCE

The Association psychanalytique de France (APF) was created in 1964 as a result of dissension within the Société française de psychanalyse (SFP) over the training of future psychoanalysts and the recognition of the APF by the International Psychoanalytic Association. Two factions evolved within the association. One of them, which became a majority in the SFP in November 1963, was led by Daniel Lagache, Juliette and Georges Favez, Wladimir Granoff, Didier Anzieu, and René Pujol, along with the five sponsors of the July 1963 motion (Jean-Louis Lang, Jean Laplanche, Jean-Bertrand Pontalis, Victor Smirnoff,

and Daniel Widlöcher). The group was recognized by the International Psychoanalytic Association (IPA) as the only “French Study Group.” On June 9, 1964, the association filed its bylaws, and was, after the dissolution of the SFP in January 1965, recognized as a member society of the IPA. It then had ten accredited members, 18 associates, and about 30 students. In December 1999, in addition to a guest member and eleven honorary members, there were 34 accredited members, 27 members, and more than 180 trainee analysts, including ten who would soon be eligible for membership.

The association’s general orientation was described in two talks given by Daniel Lagache in 1964 and 1965, and again by Victor Smirnoff in 1977. The association’s objectives can be found in the policy statements published each year in *Documents et Débats*, the association’s journal. These can be summarized as: freedom of expression in scientific discourse without concern for any narrowly construed form of orthodoxy, a rejection of dogmatism or any “overarching” authority; a heterodox approach to theoretical sources, leading to the coexistence of several trends in clinical psychology, dynamic psychology, Lacanian thought (exclusive of training), philosophy, and the work of Freud; the periodic revision of “classical” positions in psychoanalysis, even those not deeply rooted in psychoanalysis, especially through a rereading of Freud in the light of current understanding; an openness toward other disciplines and especially toward the various branches of the humanities; and periodic consideration of the relations of the institution to its various categories of members, including trainee analysts.

APF training is one of the most important features of the association. The reasons for the split were obviously not restricted to the questionable practices of certain members or a leadership dispute, and fundamental modifications concerning recruitment and training turned out to be essential. These issues have been an ongoing element within the APF since its inception and were concretized in the reforms of 1969–1971, which were finally completed in 1978. They can be summarized as follows: elimination of the training analyst under institutional control and elimination of the group of training analysts, and complete separation between institutional bodies and personal analysis. Regardless of where the original analysis occurred, this separation was appreciated by the members of the training committee before whom candidates for admission appeared as trainee analysts; once

accepted, they were allowed to participate from the outset in scientific and teaching activities. The approval of controlled analyses was a joint effort of the members of the training committee, since they alone were authorized to do so, acceptance into the program (including participation in classes) being the responsibility of the members’ council. The candidate was then asked to present a paper before being accepted as a member, which was submitted to a vote by the members.

This system, which did not comply with the customary practices issued by the IPA (in the “French” system, members alone are responsible for training), has always been a topic of discussion and is currently oriented toward the conditions of supervision and the paper. It should also be pointed out that trainee analysts participate at every level of the life of the institution and are represented, separately and independently of the training committee, on all the committees, and even participate in the association’s administrative affairs. There is also a welcoming and study group for new candidates.

Teaching, which is under the supervision of an ad hoc committee, is not separate from the association’s scientific and research activities. It consists primarily in conferences and discussions, group activities, periodic meetings to discuss clinical issues or technique, and research groups. It is not mandatory and is not subject to individual control. Members can participate in these activities as soon as they are accepted into the program. In 1999 there were 32 groups or seminars open to trainee analysts; a number of full members were participants as well.

Scientific activities, also under committee control, consist (in addition to the research groups mentioned above) in monthly meetings often focused on an annual topic, two annual colloquia (the “Entretiens,” formerly the “Entretiens de Vaucresson”), and two annual days reserved for active members and also involving a specific subject. There are also a number of Open Sessions, such as the current “Soirées de l’APF” (three per year), and APF participation in a number of French, European, and International colloquia, two of which, the Congress of French Languages and the Journées Occitanes, are organized with the assistance of the APF.

Five issues of the *Bulletin intérieur de l’A.P.F.* were published between 1964 and 1969. This was followed

by *Documents et Débats*, which ran from October 1970 to December 1999, that is, 52 issues. A periodical newsletter and annual report on the activities of the association are also published. The APF has no journal of its own but its members are active participants in the publication of several specialized journals: the *Nouvelle revue de psychanalyse*, created in 1970 by Jean-Bertrand Pontalis, *Psychanalyse à l'université*, created in 1975 by Jean Laplanche, *L'Écrit du temps*, and *L'Inactuel* by Marie Moscovici, *Le fait de l'analyste* by Michel Gribinski. In addition to reprinting Jean Laplanche and Jean-Bertrand Pontalis's *The Language of Psycho-Analysis*, the association supervised the translation of the complete works of Sigmund Freud, published by Presses Universitaires de France (PUF) under the direction of Jean Laplanche and André Bourguignon, with the collaboration of Pierre Cotet and François Robert (in progress; the final work will comprise 21 volumes). Member publications appear in collections edited by a member of the APF in the following series: Bibliothèque de Psychanalyse, published by PUF under the direction of Jean Laplanche; Connaissance de l'Inconscient, published by Gallimard under the direction of Jean-Bertrand Pontalis; and Psychismes and Inconscient et Culture, published by Dunod under the direction of Didier Anzieu.

Although relatively small in size and with little desire for expansion or control, the APF remains ambitious in its goals and open to new ideas. Its headquarters and secretariat are located at 24 Place Dauphine in Paris. It is here that the association's councils and committees meet and where the association's library, containing some four thousand volumes and documents, is housed.

JEAN-LOUIS LANG

### Bibliography

- Arfouilloux, Jean-Claude. (1989). La formation dans la S.F.P. et dans l'A.P.F. Malaise dans la culture analytique. *Revue internationale d'histoire de la psychanalyse*, 2, 343–368.
- Lagache, Daniel. (1986). Adresses présidentielles. In *Oeuvres* (Vol. VI. La folle du logis, la psychanalyse comme science exacte, pp. 149–158). Paris: Presses Universitaires de France.
- Mijolla, Alain de. (1995). Splits in the French psychoanalytic movement between 1953 and 1964. In R. Steiner and J. Johns (Eds.), *Within time and beyond time* (pp. 1–24). London: Karnac, 2001.

Smirnoff, Victor. (1977, April). Intervention. *Documents et Débats*, 13, 17–22.

## ASTHMA

Due to its frequent association with psychoaffective symptoms, asthma is considered a classic psychosomatic disorder. The Hungarian-American analyst Franz Alexander was an early proponent of psychosomatic medicine, and during the 1940s he and Thomas French applied the “specific emotion theory” to try to establish a link between the onset of asthmatic attacks and emotional conflicts. Their research suggested that pregenital instinctual desires, experienced as threatening to the dependent mother-child dyad, could give rise to bronchial symptoms, noting that breathing is the first independent post-natal physiological function. It is possible to view the infant's double separation from the mother—biological and psychoaffective—as reviving the Freud-Rank birth trauma debate. A generation later in 1963, research by Peter Hobart Knapp suggested that allergic diathesis was a necessary precondition to developing symptoms, and offered as possible triggering mechanisms either hysterical conversion or conflicts of oral incorporation expressed through the respiratory apparatus.

In France, Pierre Marty, one of the founders of the *Ecole de Psychosomatique de Paris*, theorized that asthma, like other allergic manifestations, arises from a specific type of object relationship that involves a form of profound and almost instantaneous mimetic identification that includes a projective movement identifying object with subject. The difficulty of maintaining such a state of confused fusion either produces some accommodation or, in the case of an intractable object, creates a distance from the object that may be considered at once symbolic and real. The separation from the object whose own characteristics are too distant from, or independent of, the subject, occurs without the work of mourning. The asthmatic attack breaks out during conflict between two objects, both equally invested but themselves in conflict. The asthmatic attack externalizes and diverts internal psychological destruction.

ROBERT ASSÉO

See also: Allergy; Psychosomatic.

### Bibliography

- Alexander, Franz, and French, Thomas M. (1941). *Psychogenic factors in bronchial asthma*. Washington, DC: National Research Council.
- Bauduin, Andrée. (1985). L'asthme bronchique, aspects dynamiques et psychanalytiques. *Revue médicale de Liège*, 90 (22).
- Fenichel, Otto. (1953). *The collected papers of Otto Fenichel. First and second series* (H. Fenichel and D. Rapaport, Eds.). New York: Norton.
- Knapp, Peter H. (1989). *Psychosomatic aspects of bronchial asthma*. Madison, CT: International Universities Press.

## ASTHMA IN CONTEMPORARY MEDICINE AND PSYCHOANALYSIS

A fairly uncommon disease in 1900, a century later asthma represented a growing international health problem. Although the early psychosomatic models proposed by Alexander, Fenichel, and other first and second generation analysts were eventually supplanted, numerous research efforts in a variety of disciplines have failed to develop a comprehensive understanding of the disorder. Although asthma is treatable as a chronic condition, it remains poorly understood.

The original psychoanalytic research into asthma in American medicine represents a historical point of reference in subsequent reviews of the literature. But from a medical point of view, its specific hypotheses could not be easily refined for further research, while typology of the disorder itself changed considerably. In the mid-twentieth century Hans Selye's holistic concept of stress created grounds for a macrocosmic explanation that ultimately proved valuable, if unquantifiable. At the same time, investigations into the physiology, immunology, and genetics of asthma all yielded significant, though sometimes conflicting, results. Although this research helped create a pharmacological armamentarium for palliative treatment, studies in all these areas only reinforced the hypothesis that psychological factors play significant roles in asthma, which continues to qualify as a psychosomatic disorder. In this context, psychoanalysis remains a plausible treatment for reducing symptomatic attacks and alleviating frequently comorbid conditions, such as anxiety and depression, as do other modalities, including relaxation therapy, hypnosis, and other types of psychotherapy.

More recent psychoanalytic conceptualizations of asthma include work by Judith Mitrani (1993) from a

post-Kleinian perspective; she describes asthma as one of a number of disorders that in some cases may be viewed as arising from persistent primitive mental states in the context of what Esther Bick terms "adhesive identification."

JOHN GALBRAITH SIMMONS

See also: Asthma; Adhesive identification; Psychosomatic.

### Bibliography

- Fenichel, Otto. (1945). *The psychoanalytic theory of neurosis*. New York: Norton.
- Gregerson, M. Banks. The curious 2000-year case of asthma. *Psychosomatic Medicine*, 62, 816–827.
- Mitrani, J. (1993). "Unmentalized" experience in the etiology and treatment of psychosomatic asthma. *Contemporary Psychoanalysis*, 29 (2), 314–342.
- Wright, R. J., Rodriguez, M., and Cohen, S. (1998). Review of psychosocial stress and asthma: an integrated biopsychosocial approach. *Thorax*, 53, 1066–1074.

## ATTACHMENT

The term *attachment* is used in contemporary scientific literature in four distinct senses: a form of behavior whose goal is to maintain proximity to the other person (smiles, vocalization, tears, approach behavior); the bonds of attachment that are related to the affiliation between parents and children; the system of attachment, in which the child's goal is to seek proximity with the attachment figure and obtain an internal feeling of security; and, finally, relationships that involve the offer of attention, emotional availability, and the search for comfort in parent-child relations.

Attachment is a behavioral control system of biological origin, which involves the use of the attachment figure by the child as a "secure base" from which it can explore the environment. In John Bowlby's theory, the form assumed by the child's attachment is based on its actual interactive experiences with its attachment figures and not with the fantasies they arouse. These feelings of security or insecurity (anxious attachment, resistant attachment, avoidance attachment, disorganized attachment) about the parental figures are organized during the first year of life in the form of an "internal model of work" that will give rise to stable forms of reaction in the face of distress and novelty.



From the start of the twentieth century, the medical literature was cognizant of the effects of the lack of maternal care of infants (Chapin, 1916; Spitz, R., 1945). In 1951 Bowlby wrote a monograph on maternal care and mental health. In 1959 Harlow, working with primates, provided experimental proof of the independence of attachment and the satisfaction of physiological needs. This led Bowlby to propose, in 1969, the concept of “attachment behavior” and to emphasize its importance for normal development. Bowlby’s student Mary Ainsworth proposed the experimental paradigm of the “strange situation,” which could be used, in the laboratory or at home, to study the reactions of infants over a year old to the presence of a stranger, followed by a short separation and reunion. It was used to classify attachment behavior with either of the parents into types: secure attachment (type B) against various insecure attachments (anxious-avoidant, or type A; anxious-resistant, or type C; and disorganized, or type D). The work of Mary Main focused on describing parents’ speech about their children and in classifying it into coherent, avoidant, involved, or disorganized types. Longitudinal studies show a clear correlation between the speech category of the parent most directly involved with the child and the type of attachment formed by the child. The relation appears clearly during experiences of absence and abuse and the phenomenon of disorganized attachment.

Attachment is not a psychoanalytic concept; it is part of ethology. However, the concept was developed and applied within the context of psychopathology and the study of infant development by a psychoanalyst, a leading member of the British Society of Psychoanalysis, who had been responsible for training for many years. To the great regret of its inventor, the concept of attachment, although it underwent considerable development in the field of developmental research, was not extensively used in clinical practice, at least, not until recently. Of course, the concept of attachment clashes with the classical theory of anaclisis. It is also true that from the point of view of attachment theory, infantile sexuality is of little importance and the emphasis is on the real and repeated experiences of early childhood. However, contemporary psychoanalysts would be wrong to neglect this essential dimension of human relations, important because of its development in the first year of life, the formation of the different styles of attachment described by Main and observable after the first year of infancy in Ainsworth’s “strange situation,” as well as the persistence of attachment in adolescent and adult life. Attachment

theory clarifies the development of early parent-infant relations and the modes of organizing representations.

Finally, there is remarkable convergence between the concept of attachment and psychoanalytic theory in the work of John Bowlby and Mary Main on the transgenerational transmission of styles of attachment through the consistency of parents’ speech concerning their own infancy. Starting from the “secure base” represented by the analyst, the patient can explore the disturbances in his earliest relationships and eliminate their continuation in his interpersonal relations and their transmission to his own children through the expression, in narrative form, of his emotional experience, which is re-expressed in the transference. The concept of attachment assumes its place in psychopathology as a tool for analyzing early development and exploring its structure in the psychoanalytic experience.

ANTOINE GUÉDENEY

*See also:* Abandonment; Amai, concept of; Anaclisis/anaclitic; Aphanisis; Bowlby, Edward John Mostyn; Ethology and psychoanalysis; Individual; Infant development; Infantile neurosis; Maternal; Maternal care; Primary need; Sucking/thumbsucking; Tenderness.

### **Bibliography**

- Ainsworth, Mary; Blehar M.C.; Waters E.; et al. (1978), *Patterns of attachment: A psychological study of the strange situation*, Hillsdale, N.J.: Lawrence Erlbaum.
- Bowlby, John. (1969). *Attachment and loss* (Vol. 1). London: Hogarth Press.
- . (1988). *A secure base: Clinical applications of attachment theory*. London: Routledge.
- Holmes, J. (1993). *John Bowlby and attachment theory*. London: Routledge.
- Main, Mary, Kaplan, N., Cassidy, Jude. (1985). Security in infancy, childhood and adulthood: A move to the level of representation. *Monographs of Society for Research in Child Development*, 50 (1–2), 66–104.
- Spitz, René. (1945). In R. S. Eissler, (Ed.), *The psychoanalytic study of the child* (Vol. I). New York: International Universities Press.
- Chapin, H.D. (1916). A scheme of state control for dependent infants. *Medical Record*, 84, 1081–1084.

---

## **ATTENTION**

The word “attention” comes from the Latin *attention*, itself derived from *attendere*, which means “to turn

one's mind towards"—to turn one's mind or perhaps one's senses. In any case, the term is currently very ambiguous, and all the more so since it is used in different senses by researchers and clinicians referring to quite varied epistemological horizons.

In France, Didier Houzel has made the most careful study of the concept in recent years, notably in relation to infant observation. According to this author, if the function of attention is only rarely mentioned in the psychoanalytic literature, it is in part due to the ambiguity it evokes and also in part because attention is traditionally linked to consciousness without there ever existing any clear definition of a possible unconscious attention.

Freud mentions attention for the first time in his book *On Aphasia* (1891b), where he discusses divided attention (*geteilte Aufmerksamkeit*): "When I read proofs with the intention of paying special attention to the letters and other symbols, the meaning of what I am reading escapes me to such a degree that I require a second perusal for the purpose of correcting the style. If, on the other hand, I read a novel, which holds my interest, I overlook all misprints and it may happen that I retain nothing of the names of the persons figuring in the book except for some meaningless feature or perhaps the recollection that they were long or short, and that they contained an unusual letter such as x or z. Again, when I have to recite, whereby I have to pay special attention to the sound impressions of my words and to the intervals between them, I am in danger of caring too little about the meaning, and as soon as fatigue sets in I am reading in such a way that the listener can still understand, but I myself no longer know what I have been reading. These are phenomena of divided attention which are of particular importance here" (pp. 75–76).

Freud thus attributed to attention an ability to forge links between different components of the sensory data constitutive of the word, distancing himself from localizationist theories of aphasia. In this linking function of attention, one can see the precursor of what would later come to be called "suspended attention" of the analyst and its crucial characteristic of non-selectivity, which is an important component of technique.

It was in the *Project for a Scientific Psychology* (1950c [1895]) that Freud proposed an actual theory of attention. Having distinguished between  $\Psi$  neurons sensitive to quantities of excitation and x neurons sensitive to qualities of excitation, he defined attention as a hypercathexis of the indications of quality that are

perceived by the x neurons but as hypercathected by an energy issuing from the  $\Psi$  neurons. He made attention capable of expectation in that it was responsible for apprehending indications of quality from perception and thus anticipating cathexis by wishes.

Thus Freud distinguished "ordinary thought," directed toward the search for an object of satisfaction, and "observing thought" (1950c [1895], p. 363) which is turned more towards the internal world than the external and is supported by the function of attention. According to him, attention has one valence directed toward the interior, or the intrapsychic world, and it is this centripetal attention that allows neuronal facilitations that would be impossible with only centrifugal attention.

In *The Interpretation of Dreams* (1900a), he assigned attention the task of transmitting psychic material from the preconscious system to the conscious system, thus giving a certain primacy to continuous attention. In 1911, he specified the dynamic character of attention in his article, "Formulations on the Two Principles of Mental Functioning": "A special function was instituted which had periodically to search the external world in order that its data might be familiar already if an urgent internal need should arise—the function of *attention*. Its activity meets the sense-impressions half way, instead of awaiting their appearance" (1911b, p. 220). He was here underscoring the active aspect of the function of attention.

Freud returned to the question of attention yet again in "Recommendations to Physicians Practising Psycho-Analysis" (1912e), where he defined "evenly-suspended attention" as the desirable attitude of the analyst during the session. This attitude, which certainly puts less strain on the analyst, is justified mainly on the grounds that non-selectivity toward clinical material, as the counterpart for the analyst of the rule of free association for the patient, promotes a more direct contact between the ideational worlds of the two participants.

Wilfred Bion extended the concept of attention beyond sensory reality and applied it to psychic reality, a direction that Freud had indicated in *An Outline of Psycho-Analysis*. This theme is central to Bion's book *Attention and Interpretation* (1970), in which he described attention as the matrix within which the diverse elements of mental life come to be united and combined. Thus the Bionian perspective is highly dynamic.

Moreover, on the interpersonal level, Bion described the "mother's capacity for reverie" (Bion, 1967, p. 116),

referring to the “function” by which, thanks to her processes of attention, capacity, and transformation, the mother helps the child to render his or her environment thinkable so that the child will be progressively able to integrate it into its own “apparatus for dealing with thoughts” (Bion, 1962, p. 83). What is fundamentally involved is a work of detoxification that makes it possible for the child to metabolize (on the digestive model of the psyche) protopsychic materials that are at first unusable by the child alone.

Maternal attention represents a first step towards and an essential precondition for the work of transformation that Bion referred to as equally important to his experimental paradigm, which was that of analytic treatment, and especially the treatment of psychotic adults. He recommended that analysts be without “memory and desire” (1970, p. 31), which is certainly not to be taken literally, but aims to create in the analyst a particular state of attention and perhaps, according to Houzel, an unconscious state of attention.

The most recent work in the field of early childhood analysis, especially that of the post-Kleinians, places more and more emphasis on attention as the cornerstone of the therapeutic process.

BERNARD GOLSE

*See also:* Active imagination (analytical psychology); Cathexis; Conscious processes; Dismantling; Framework of the psychoanalytic treatment; Free association; Evenly-suspended attention; Fundamental rule; Grid; Hypercathexis; Infant observation (therapeutic); *Learning from Experience*; Perception-consciousness (Pcpt.-Cs.); “Project for a Scientific Psychology, A”; Psychoanalytic treatment; “Recommendations to Physicians Practising Psycho-Analysis”; Sudden involuntary idea; Thought-thinking apparatus.

### **Bibliography**

- Bion, Wilfred R. (1970). *Attention and interpretation*. London: Tavistock Publications.
- . (1962). *Learning from experience*. London: Tavistock Publications.
- . (1967). *Second thoughts*. New York: Aronson.
- Freud, Sigmund. (1911b). Formulations on the two principles of mental functioning. *SE*, 12: 213–226.
- . (1900a). The interpretation of dreams. *SE*, 4–5.

———. (1891b). *On aphasia: A critical study*. (E. Stengel, Trans.). New York: International Universities Press, 1953.

———. (1912e). Recommendations to physicians practising psycho-analysis. *SE*, 12: 109–120.

---

## **AUBRY WEISS, JENNY (1903–1987)**

Jenny Aubry Weiss, a physician in the Hospitals of Paris and French psychoanalyst, was born on October 8, 1903, in Paris, where she died on January 28, 1987. She was born into an upper-middle-class family; her mother was Jewish and her father Protestant. She studied medicine and interned with Clovis Vincent, was an assistant with Georges Heuyer, and, in 1939, was the second woman to be appointed as a physician in the Hospitals of Paris. In 1928 she married Alexandre Roudinesco, a pediatrician, with whom she had three children. She later divorced Roudinesco and married Pierre Aubry in 1952.

In 1939 she became a physician at an institute for gifted children (the first in France). She accepted a number of Jewish children and hired a number of Jewish personnel, saving them from the concentration camps. She prepared certificates of tuberculosis for young men likely to be sent to the forced labor camps in Germany. In 1944 she received the Medal of the Resistance. She was head of the pediatrics department of the Ambroise Paré Hospital in 1946, of the polyclinic on the Boulevard Ney in 1952, and of the pediatrics department of the Hôpital des Enfants Malades from 1956 to 1968. She met Anna Freud in 1948 and began psychoanalysis with Michel Cénac, Sacha Nacht, and Jacques Lacan, whose loyal supporter she remained during the sectarian battles of 1953 and 1963.

An excellent clinician, she realized quite early in her professional life that psychoanalytic insight can help to understand the development of children and their illnesses. Convinced of the importance of interactions between mother and child, mother and father, and parents and children, and of the key role played by the mother-child-father relationship, she was able to verbalize children’s suffering and help their parents make sense of their physical and psychic disturbances. The publications, films, and papers she produced bear witness to this, as do her many innovations in the hospital, where she managed to create a pleasant and friendly environment within a recreational framework. She persevered in her efforts to create positions for kindergarten teachers and educators, and she included psychoanalysts on her staff.

In 1948 she appointed a teacher for her young patients and studied dyslexia. She brought psychoanalysts to the school for gifted children. She initiated a research program on the lack of maternal care with John Bowlby, and she formed a team with Myriam David to observe and establish analytic cures for children assigned to her department (Dépôt d'enfants de parents de Rosan). In 1950 she created a specialized family-placement service so that children under her care could benefit from a family environment and analysis.

Through the World Health Organization, she helped found, in July 1950, the first Guidance Center for Children in Soissons, France. In 1952, together with Odile Lévy-Bruhl and Raymonde Bargues, she studied children in the hospital day-care center and their entry into a preschool setting. In 1954 she was asked by the World Health Organization to study abandonment and child development in Africa. At the Hôpital des enfants malades, with Raymonde Bargues, Ginette Raimbault, Anne-Lise Stern, and René Tostain, she trained pediatricians and nurses to be sensitive to the needs of children and parents, and established a psychoanalytic practice. From the hospital administration she obtained approval for parents to visit from noon to 8:00 p.m.

After her retirement to Aix-en-Provence in 1968, she helped promote psychoanalysis in southeast France. In 1971 she organized and introduced the meeting of the École freudienne de Paris (Freudian School of Paris). After the death of Pierre Aubry in 1972, she returned to Paris, where she resumed her psychoanalytic practice, served as a training analyst, and remained an active participant in the École freudienne de Paris until its dissolution in 1980.

MARCELLE GEBER

See also: France; Technique with children, psychoanalytic.

### **Bibliography**

- Aubry, Jenny. (1983). *Enfance abandonnée*. Paris: Scarabée-Métallier.
- Bargues, René. (1964) Les nourrices d'un placement familial curatif des carences affectives graves de la première enfance. *Évolution psychiatrique*, 3.
- Lévy-Bruhl, Odile, and Aubry, Jenny. (1956). L'adaptation à l'école maternelle. *Enfance*, 1.
- Roudinesco, Jenny, Trélat, Jean, and Trélat, M. (1949). Étude de quarante cas de dyslexie d'évolution. *Enfance*, 1.

Roudinesco, Jenny; David, Myriam; Nicolas, J.; et al. (1952). Réactions immédiates des jeunes enfants à la séparation d'avec leur mère. *Courrier du C.I.E.*, 2–3, 66–78, 131–142.

## **AULAGNIER-SPAIRANI, PIERA (1923–1990)**

A physician, psychiatrist, and psychoanalyst, Piera Aulagnier-Spairani (formerly Castoriadis-Aulagnier) was born on November 19, 1923, in Milan, Italy, and died on March 31, 1990, in Paris.

She studied medicine in Rome, her early medical calling marked by her sustained focus on clinical practice. In 1950 she moved to France, where she completed her studies in psychiatry.

She trained in psychoanalysis with Jacques Lacan from 1955 to 1961. As his student, she joined ranks with him when he was expelled from the Société française de psychanalyse (French Society of Psychoanalysis) in 1963, and she was among the psychoanalysts who first formed the École freudienne de Paris (Freudian School of Paris) in 1964. True to her personal standards of rigor, she later resigned from that organization when she found herself in disagreement with Lacan's positions on the training of psychoanalysts.

In 1969, immediately after her break with Lacan, along with François Perrier, Jean–Paul Valabrega, and other analysts, she founded the Fourth Group of the O.P.L.F. (Organisation psychanalytique de langue française [French-language psychoanalytic organization]) in which she remained a central figure, although it was never her wish to impose a hierarchical structure within the group.

Throughout these tumultuous years, she was known for her independent-mindedness and the calm in debates that led her to abstain from participating in vain polemics. However, her reserve was never synonymous with indifference. Her concern about the risk of conformity that threatens psychoanalytic and indeed other societies led her to denounce that tendency in 1969, when she wrote, “the audacity and genius needed to transgress accepted wisdom do not guarantee that the transgressors will be able to pass on to their heirs the ability to dismantle the barrier that has been broken through.”

This spirit was reflected in her activity in the two she successively founded at the Presses Universitaires de France: *L'Inconscient*, with Jean Clavreul and Con-

rad Stein in 1967–1968, and then *Topique*, beginning in 1969. In both publications, pluralism and respect for the authors' thought always won out over issues of institutional affiliation.

Daily clinical practice and the ongoing pursuit of her writing were intimately linked for Aulagnier. In 1975, while she was married to Cornelius Castoriadis, her first book, *The Violence of Interpretation: From Pictogram to Statement* (under the name Piera Castoriadis-Aulagnier) was published by the Presses Universitaires de France. This work became an obligatory reference for those who felt the need, based on the clinical treatment of psychosis, to reexamine Freudian metapsychology. Two other books, published under the name Piera Aulagnier, followed: *Les Destins du plaisir. Aliénation, amour, passion* (1979; The destiny of pleasure: Alienation, love, passion) and *L'Apprenti-historien et le maître sorcier. Du discours identifiant au discours délirant* (1984; The apprentice historian and the master sorcerer: From the discourse of identification to the discourse of delusion); these books also found a broad readership. The long series of articles written beginning in 1961, most of them published in *Topique*, the revue she headed from its founding in 1969, were collected and reprinted in *Un interprète un quête de sens* (An interpreter in search of meaning; 1986).

All are indebted to Aulagnier for a new approach not only to psychosis, but also a new theory of representation that considers the psychotic's relationship to discourse. Beyond this, she established an entirely new theorization of the *I* and the conditions in which it comes into being. Her conceptual inventions emerged in close connection with clinical practice and under strict critical self-scrutiny, leaving those who knew her with lasting impressions of her tireless and passionate interest in the fundamental issues not just of psychoanalysis, but of human experience.

SOPHIE DE MIJOLLA-MELLOR

*See also:* École freudienne de Paris (Freudian School of Paris); France; *Inconscient, L*; Interpretation; Pass, the; *Psychanalyse et les nevroses, La*; *Topique*; Viderman, Serge.

### **Bibliography**

Mijolla-Mellor, Sophie de. (1998). *Penser la psychose. Une lecture de l'oeuvre de Piera Aulagnier*. Paris: Dunod.

Troisier, Hélène. (1998). *Piera Aulagnier*. Paris: Presses Universitaires de France.

## **AUSTRALIA**

Sigmund Freud wrote his short paper "On Psychoanalysis" in response to an invitation from Andrew Davidson, the Secretary of the Section of Psychological Medicine and Neurology for the Australasian Medical Congress in Sydney in September 1911. Papers by Carl Jung and Havelock Ellis were also presented. Ernest Jones was another distinguished early contributor, for he personally read a paper at the Australasian Medical Congress in 1914 entitled "Some Practical Aspects of Psychoanalytic Treatment."

Two notable Australian figures who accepted Freud's challenge to develop the study of psychoanalysis were Paul Greig Dane and Roy Coupland Winn, who practiced between the two world wars. Before the World War I (1914–1918) a Presbyterian clergyman, Donald Fraser, had lectured on psychoanalysis in Sydney, but Dane appears to have been the first physician to become a wholehearted and consistent exponent of Freud's early theories in the careful use of catharsis and abreaction after the war. Paul Dane's interest in psychological methods of treatment was stimulated by the work of earlier pioneers such as John William Springthorpe and Clarence Godfrey. Dane was one of the first in Australia to use hypnosis and abreactive techniques. He also introduced group therapy for returned soldiers. His interest stemmed from contact with Joan Riviere in England. Dane, although not an analyst himself, was the first chairman of the Melbourne Institute for Psychoanalysis and was intimately associated with its foundation and early history. Dane died in 1950.

Siegfried Fink, an associate member of both the Swiss and the British Psycho-Analytical Societies, worked in Sydney until his death in the 1960s. Fink was thus a contemporary of both Dane and Winn. He was one of the founding councilors of the Sydney Institute for Psychoanalysis.

Roy Coupland Winn, after serving with great distinction in World War I, returned to the medical staff of Sydney Hospital and after several years went to London to continue medical and psychiatric training, becoming an associate member of the British Psycho-Analytical Society and later a full member. Back in Sydney, for several years he was Honorary Physician at Sydney Hospital but in 1931 he resigned and went into full-time psychoanalytic practice.

Winn was thus the first full-time analyst in Australia. Later, when Clara Lazar-Geroe came to Australia from

Hungary and began to train analysts at the Melbourne Institute, Winn was very supportive. He joined the Board of Directors of the institute, a position that he held until his death in 1961. In 1951 he had made a generous endowment in founding the second training institute in this country, the Sydney Institute of Psychoanalysis, with Andrew Peto, also from Hungary, as training analyst (Graham, 1965).

Clara Lazar Geroe, the first Australian training analyst, arrived in Melbourne on March 14, 1940. She received her training in medicine in Prague. Her psychoanalytic training in Budapest naturally was in the school of Sandor Ferenczi, her training analyst being Michael Balint.

At the International Psychoanalytical Congress in Paris in 1938, Ernest Jones suggested that Hungarian analysts seeking emigration might consider New Zealand and Australia. Negotiations regarding New Zealand failed. "However, in Melbourne and Sydney some influential people, among them Bishop Burgman, Paul Dane, M. D. Silberberg, Reginald S. Ellery, and Roy Coupland Winn, reacted positively to the idea of an analyst coming to Australia. Their enthusiasm, and the enterprise of Paul Dane particularly, carried the day. After much negotiation, Geroe, with her family, settled in Melbourne to become Australia's first training analyst working at the newly formed Melbourne Institute for Psychoanalysis. She had been appointed as a training analyst by the British Psycho-Analytical Society of which she was a member" (Graham, 1980).

The founding of the first institute was made possible by a generous gift from Lorna Traill. The first meeting was held in the home of Hal Maudsley, a central figure in the history of psychiatry in Australia. The institute was opened at 111 Collins Street, Melbourne, by Judge Foster on the birthday of its benefactor, Lorna Traill, on October 10, 1940. The first Board of Directors included Paul Dane, Norman Albiston, Reginald S. Ellery, P. Guy Reynolds, and A.R. Phillips. There were two psychoanalysts on the Board, Ernest Jones of London and Roy Coupland Winn from Sydney. Geroe started her work with the institute and in private practice early in 1941. She conducted a large seminar for twenty to twenty-five doctors, psychiatrists, psychologists, educationists, probation officers, and others.

The traditional small seminar method was followed for candidates in training, both medical and non-medical. Geroe also organized many other seminars for groups of teachers, kindergartens, and parents for

discussion of their special problems with infants and children. The Institute Clinic catered to patients who could not afford private analytical fees; Geroe's Child Guidance Clinic developed a close liaison with the Children's Court clinic. Geroe lectured for many years in the Psychology Department of the University of Melbourne and to students taking the Diploma of Psychological Medicine. She was appointed Honorary Psychoanalyst at Royal Melbourne Hospital—certainly the first appointment of this type in Australia.

The first medical student to go into training in Australia was Frank Graham, who started with Winn in 1939, then began training with Geroe in 1941. The first psychiatrist or medico to train was A.R. Phillips and the first lay analyst Janet Nield.

Early on, psychoanalysts qualified or in practice in Australia were all members or associate members of the British Psychoanalytical Society. They formed "The Australian Society of Psychoanalysts," a sort of unofficial branch of the British Society but having no independent status. Harry Southwood and Frank Graham were the first to graduate in Australia in this way as associate members of the British Psycho-Analytical Society.

In 1966 the British Society suggested that this interim arrangement should be formalized by an Australian application to the International Psychoanalytical Association for Study Group status. At the IPA Congress at Copenhagen in 1967, with the support of the British Society, the Australian Study Group was established under the direction of an international Sponsoring Committee. At this stage, there were twelve Australian psychoanalysts, members of the Study Group, who were appointed direct members of the IPA. They were: O.H.D. Blomfield, R.A. Brookes, Clara Lazar Geroe, Frank W. Graham, I.H. Martin, R. Martin, J. Nield, D. O'Brien, V. Roboz, Rose Rothfield, H.M. Southwood, and I. Waterhouse.

Of the seven members of the IPA Sponsoring Committee, Fanny Wride (chair), Adam Limentani, Ilse Hellman, Lois Munro, and Leo Rangell all visited Australia at various times and helped with clinical and structural development. The other members of the Sponsoring Committee were Maria Montessori and M. Mitscherlich-Nielson.

In Vienna, in July 1971, the IPA at its business meeting accepted the recommendation of the Sponsoring Committee and raised the status of the Study Group to that of Provisional Society. After the requisite two years as a Provisional Society, the Australian Psycho-

analytical Society was admitted as a Component Society of the International Psychoanalytical Association at the IPA Congress in Paris in 1973. The constitution of the third Institute in Adelaide in 1979 represented the fruition of many years of dedicated and determined work by Harry Southwood. Assistance by the IPA was required in relation to the coordination of training in the three centers. The IPA appointed two Site Visiting Committees. The first in 1980 (Drs. Joseph, McLaughlin, Moses) and the second in 1987 (Dr. Cooper, Prof. Sandler.)

Over the years, Australian analysts have been encouraged and stimulated by working visits by distinguished colleagues—the outstanding ones in the sixties being Michael Balint and Enid Balint. Other influential invited visitors included Betty Joseph, Edna O'Shaughnessy, Sydney Klein, and Anne-Marie Sandler.

Apart from these visits, the isolation of the Australian Society has been mitigated by the fact that many members completed their initial training with the British Society or have spent long periods in London for further analysis, supervision, or seminar work. Non-medical analysts have played an important part in the growth and development of psychoanalysis. From the beginning psychoanalysis has been viewed as a separate discipline in its own right.

Psychoanalysis has had a marked influence in many areas, most particularly in child psychiatry and social work. Following the lead of Paul Dane in the treatment of ex-servicemen in the Commonwealth Repatriation Department, Frank Graham introduced psychoanalytically oriented group therapy at the Royal Melbourne Hospital in 1950 and later inspired the formation of the Australian Association of Group Psychotherapists.

In the academic world, some departments of psychology have psychoanalysts on the staff or maintain a working contact with psychoanalysts, as do several departments of philosophy, sociology, and politics; the law has been less influenced. The first publicly advertised senior position on the medical staff of a major teaching hospital for a psychoanalyst was established largely through the efforts of William Orchard at Prince Henry's Hospital Melbourne, in about 1970. Frank Graham was the first appointee. Another appointment of this kind was Janet Nield as Honorary Psychotherapist (1953–71) at The Royal Alexandra Hospital for Children in Sydney.

In the 1990s, a widening of the field of activity of the Australian Psychoanalytical Society has involved contributions by the society or its members to university teaching (at MA and PhD levels) and open seminars. There is a growing list of publications and public lectures by members. The Freudian School of Melbourne and The Australian Centre for Psychoanalysis in the Freudian Field are devoted to the Lacanian approach in Melbourne. There is an active school of Self-Psychology (Heinz Kohut) based in Sydney. Graduates of the American Academy of Psychoanalysis (Karen Horney) have played an active role in developing psychoanalytic psychotherapy in the Psychotherapy Association of Australia.

O. H. D. BLOMFELD

### **Bibliography**

- Blomfield, O.H.D. (1986). Psychoanalysis in Australia. *Journal of the International Association for the History of Psychoanalysis*, 2, 9–11.
- Brett, Judith. (1998). Clara Lazar Geroe. In *Australian dictionary of biography*. Melbourne: Melbourne University Press.
- Brett, Judith, Gold, Stanley, and Geroe Clara. (1982, September). Psychoanalysis in Australia. *MEANJIN*, 41 (3), 339–357.
- Graham, Frank W. (1965). Obituary: Dr. Roy Coupland Winn. *International Journal of Psychoanalysis*, p. 616.
- . (1980). Clara Lazar-Geroe. An Obituary. *International Journal of Psycho-Analysis*, p. 603.

### **AUSTRIA**

The history of psychoanalysis in Austria is practically indistinguishable from that of the Vienna Psychoanalytic Society until the end of the Second World War. The group known as the Wednesday Psychological Society, which met regularly after 1902 in Freud's apartment, later renamed itself the Wiener psychoanalytische Vereinigung (Vienna Psychoanalytic Society) and was admitted as a regional group into the International Psychoanalytical Association, which had just been founded. In 1911, following the defection of its first president, Alfred Adler, Freud assumed the presidency. When Carl Gustav Jung and the members of the Zurich society left the

psychoanalytic movement, Vienna became the sole center of influence.

After a period of inactivity caused by the First World War, the society resumed its activities and, with its youngest members playing an important role, quickly established a treatment facility in 1922 and a training institute in 1924. Only in 1936, after years of migration, was the Vienna society able to take possession of the premises at Berggasse 7, where it was housed along with its training institute, treatment facility, and publishing house.

Between 1934 and 1938 Austria developed politically into an authoritarian Catholic state. Although most members of the society had shown themselves to be sympathetic to the Social-Democrats, its administration made a conscious decision to abstain from politics. On March 14, 1938, the day after German troops entered Austria and after a number of analysts had already left the country, the Vienna Psychoanalytic Society held its last meeting. Members unanimously decided that those who felt threatened should leave Austria, and that the society's headquarters would be transferred to wherever Freud happened to be. With the exception of Alfred Winterstein and August Aichhorn, the 68 active and honorary members and approximately 36 candidates left the city. Freud left with his family on June 4, 1938. Between 1938 and 1945 a branch of the Deutsches Reichsinstitut für psychologische Forschung und Psychotherapie (State Institute for Research in Psychology and Psychotherapy), directed first by Aichhorn and then by Beggattel, was established in Vienna. Under Aichhorn's presidency a group of analysts and psychologists attempted to free themselves of the command of the Reichsinstitut. In 1944 this secret group had 14 training candidates, 7 of whom later became psychoanalysts.

Following the fall of National Socialism and the end of the Second World War, Austrian analysts did two things during the period of reconstruction: first, they reconstructed the Vienna Psychoanalytic Society and got it readmitted to the International Psychoanalytical Association, and second, they attempted to bring into the fold analysts and organizations that, under the title of depth psychology, held orientations considered marginal or unorthodox.

The inauguration of the new Vienna Psychoanalytic Society took place in 1946, with August Aichhorn as

president. With assistance from Anna Freud, international recognition followed shortly, although it would take decades before the Vienna Psychoanalytic Society made any significant contact with the world psychoanalytic movement. After Aichhorn's death in 1949, Alfred Winterstein became the new president, a post he held until 1957. Under the direction of Wilhelm Solms-Rödelheim, the society continued to grow. The 1971 International Psychoanalytic Congress, held in Vienna, helped solidify the society's renewed links to international psychoanalysis.

Meanwhile, the Austrian and international student movement grew, and there was renewed interest in psychoanalysis generally. The Sigmund Freud Gesellschaft (Sigmund Freud Society), founded in 1968, together with the sociopsychiatrist Hans Strotzka and the cofounder of the Sigmund Freud Society Harald Leupold-Löwenthal, did much to make psychoanalysis better known to the population at large. Hans Hoff, professor of psychiatry, also helped establish this receptive climate.

Between 1972 and 1974 the presidents of the Vienna Psychoanalytic Society included Alois Becker, Harald Leupold-Löwenthal, Peter Schuster, Wolfgang Berner, and Wilhelm Burian. Krista Placheta became president in 1998. As of 2005, Christine Diercks was president of the society.

In 1986 the society moved to new offices at Gonzagagasse 11. As of 1988 the society had seventy members and approximately a hundred candidates, more than the number of members in the former Vienna society. With the post-1968 generation of psychoanalysts came a relaxation of the older, authoritarian climate of discussion and a broader range of issues. Two central themes for the society in the 1980s were anti-Semitism inside and outside the field of psychoanalysis and its history during and after the war. In addition, the society held debates on the relation between psychoanalysis and psychotherapy. These discussions led to a training seminar on psychoanalytic psychotherapy, which became an integral part of the general training program.

In 1989, at the annual meeting of the Vienna society, the assembled members voted, by a margin of one vote, to join the Dachverband für Psychotherapie (a supervisory organization), and later it voted to join the Psychotherapiebeirat (Psychotherapy Advisory Committee). In 1993 the Vienna Psychoanalytic Society was legally recognized as a training organization for psychotherapy and was a leader in this field.



From 1945 Igor Caruso, an important representative of the various groups associated with psychoanalysis, worked to make psychotherapy more accessible to a greater portion of the population. During the years following the war, he and the discussion circle of which he was a member succeeded in creating a psychoanalytic organization that remained in operation for a number of decades. Known as the *Österreichische Arbeitskreise für Tiefenpsychologie* (Austrian Working Group on Depth Psychology) and later renamed the *Österreichische Arbeitskreise für Psychoanalyse* (Austrian Working Group on Psychoanalysis), it initiated throughout the country a series of teaching and clinical initiatives that were Freudian in orientation.

In 1947 Caruso created the *Wiener Arbeitskreise für Tiefenpsychologie* (Vienna Working Group on Depth Psychology), an autonomous scientific community composed primarily of physicians, psychiatrists, psychologists, and theologians, most of whom were close in age. The first candidates were trained privately and without any specific professional requirements, since the group defined itself primarily as a venue for scientific discussion. For this reason an increasing number of members of the Vienna Psychoanalytic Society participated in these discussions, although some of them found the intellectual climate overly imbued with Catholicism. Because of the working group's unorthodox approach, the Vienna Psychoanalytic Society was forced to define strict boundaries between the two organizations at the start of the 1950s. These boundaries may have led to the Vienna working group, whose training guidelines were largely those used by psychoanalytic societies having a strictly Freudian orientation, to introduce a more formal and systematic structure for itself. The Vienna working group and the Vienna Psychoanalytic Society differed in ideological orientation. In place of psychological analysis, the Vienna working group aimed at an existential synthesis in the form of a universal humanity, blended different trends in depth psychology, and harked to Jung rather than Freud.

With the 1952 publication of Caruso's book *Psychoanalyse und Synthese der Existenz (Existential Psychology: From Analysis to Synthesis, 1964)*, the working group's program became more focused. After 1953 there were no explicit references to Jung's depth psychology and increasingly specific references to psychoanalysis. "Psychoanalysis" was initially understood in its techni-

cal sense, and the human aspect inherent in Freudian theory and its offshoots was enlarged in the direction of a personal psychoanalysis.

Caruso's book was translated into six languages, and thus served to spread his ideas internationally, especially in South America, where his ideas were well received. In fact, a number of South American candidates received their training in Vienna. Another example of cross-border activity is the 1954 Brussels symposium on the "Psychology of the Individual," attended by some forty psychoanalysts from several European countries. Presenters included Jacques Lacan, who gave a talk on the internal dialectics of the person in the theory and technique of psychoanalysis. As a result of his talk, Lacan became a corresponding member of the Vienna Working Group on Depth Psychology, a status he maintained until his death.

Theoretically, the working group focused on the concept of symbols and attempted to find a connection between Freudian ego psychology and personal philosophical concepts. There were increasing interdisciplinary attempts to bridge psychiatry, ethology, sociology, group dynamics (especially that of Raoul Schindler), and psychoanalysis. This expansion resulted in the founding, in Innsbruck in 1958, of the International Secretariat of the Working Groups on Depth Psychology, which was replaced in 1966 by the *Internationale Föderation der Arbeitskreise für Tiefenpsychologie* (International Federation of Working Groups on Depth Psychology) because of the growing number of participant associations.

During the 1960s different attempts to found a second world association, independent of the orthodox International Psychoanalytical Association, were made at the instigation of the German Psychoanalytic Association. Caruso and his working groups rebuffed these attempts in spite of the number of exchanges and conferences within the *Internationale Arbeitsgemeinschaft psychoanalytischer Gesellschaften* (International Working Group of Psychoanalytic Societies), founded in 1962 in Amsterdam. At this time the theoretical orientation of the working groups moved further and further away from fundamental theological concepts of Catholicism. There were increasing references to the Freudian foundations of psychoanalysis and greater emphasis on the psychosociological aspects of the field, which resulted from a growing interest in thinkers like G. W. F. Hegel, Karl Marx, and Herbert Marcuse. In 1972, when Caruso

obtained the psychology chair at the University of Salzburg, a number of circles and working groups were formed outside Vienna, and these helped spread awareness of psychoanalysis throughout Austria. In addition to the Linz Circle, created in 1958, these included groups for the study of depth psychology launched in Graz and Linz in 1973 and in Salzburg in 1974, followed by the foundation of the Austrian Society for the Study of Child Psychoanalysis in Salzburg in 1976.

This gathering trend toward orthodoxy found concrete expression when the Vienna Working Group on Depth Psychology renamed itself the Vienna Working Group on Psychoanalysis in 1988. Shortly thereafter all the other depth psychology groups followed its example. Until 1992 these groups were all governed by the Directorate of Austrian Working Groups, which was replaced in 1992 by the *Wissenschaftliche Gesellschaft der Arbeitskreise für Psychoanalyse in Österreich* (Scientific Society of Working Groups for Psychoanalysis in Austria). This society produced the journal *Texte: Psychoanalyse, Ästhetik, Kulturkritik*, the only (quarterly) Austrian journal on psychoanalysis, edited by E. List, Johannes Ranefeld, G. F. Zeilinger, and August Ruhs. Because the society met IPA standards, which the working groups had followed since 1970, it asked to be admitted to the International Psychoanalytical Association in 1997, with Ranefeld as president. A commission of inquiry was established in October 1998.

Between 1985 and 1990 an interdisciplinary group of Viennese scientists, in collaboration with the Institut culturel français, organized a two-year international seminar entitled "Psychoanalysis and Structuralism: Freud and Lacan," which included some of the best known representatives of the Lacan school. This resulted in the formation of the *Neue wiener Gruppe/Lacan-Schule*, composed of an "aesthetic" section (under the direction of Walter Seitter) and a "clinical" section (under the direction of August Ruhs). It organized regular interdisciplinary conferences, usually followed by one or more publications.

In 1984 a group of students founded the *Werkstatt für Psychoanalyse und Gesellschaftskritik* (Workshop on Psychoanalysis and Social Criticism) in Salzburg. Until 1996 the organization refused to accept any form of orthodoxy or dogmatism and insisted on maintaining a political focus. The *Werkblatt*, the organization's publication, is still published, although the organization itself no longer exists.

In 1967 Eric Pakesch, a student of Caruso, created a chair of medical psychology and psychotherapy in the Karl-Franzens-Universität Graz. At the suggestion of Hans Strotzka, a popular psychoanalyst and sociopsychiatrist, the Institute of Depth Psychology and Psychotherapy was founded in 1971 within the School of Medicine of the University of Vienna. It was intended to house psychoanalysis along with the other generally recognized schools of psychotherapy in a single facility. Eventually, psychoanalysis became its primary focus, and in the current university depth psychology clinic, run by Marianne Springer-Kremser, all practitioners use psychoanalysis or depth psychology, with the exception of one practitioner who uses systemic family therapy. A psychoanalytic focus can also be found at the university institutes of medical psychology (and psychotherapy) in the universities of Graz, Innsbruck, and Vienna (directed by W. Pieringer, G. Schüssler, and G. Sonneck, respectively). The Psychology Institute of the University of Klagenfurt, under the direction of Professor J. Menschik-Bendele, also has a strong psychoanalytic orientation.

Legislation on psychoanalysis instituted in 1992 had important repercussions for the field of psychoanalysis in Austria, for it drastically reduced the autonomy of psychoanalytic societies in their training activities and therapeutic practices. Psychoanalysis became recognized as equivalent to other therapeutic practices, so it had to comply with the general training program for psychotherapists. Before becoming a psychoanalyst, candidates had to complete a two-year program required for all forms of psychotherapy. Since health insurance recognized only some psychoanalytic treatments and reimbursement was partial, the five principal Viennese psychoanalytic and depth-psychology associations decided to create a parent organization in 1997 to make special agreements with insurers for long-term psychoanalytic treatment. For the first time in the history of psychoanalysis in Austria, member and nonmember associations of the International Psychoanalytical Association worked together in an organization to promote their mutual interest. Thanks to the concerted efforts of these societies, the Viennese municipal health service began to offer analyses for fifty citizens, without restriction as to duration or the frequency of treatment. Sixty years after Vienna's *Ambulatorium* shut down under Nazi administration, this treatment center reopened in 1999 and represented another sign of reawakened interest in psychoanalysis. Finally, plans for the *Wiener Arbeitskreis*

für Psychoanalyse to join the IPA moved forward when it was granted study group status in 2003.

Another important parent organization for psychoanalysis is the Sigmund Freud Society and Sigmund Freud Museum at Berggasse 19 in Vienna. The society, founded in November 1968 with the help of Anna Freud, succeeded in creating a museum where Freud had his consulting room. In addition to supporting research into the history of psychoanalysis and its founders, the society holds discussions on important contemporary clinical, sociocultural, and therapeutic issues in a spirit of interdisciplinary cooperation. Harold Leupold-Löwentahal, president of the Society from 1976 to 1998, was succeeded by Johannes Schüle, who presided until 2003, and Dieter Bogner. The library, with 25,000 volumes, represents one of the major collections of its kind in Europe and includes archives with over 50,000 records of all kind. Since 1997, at the instigation of American artist Josef Kosuth and Austrian art dealer Peter Pakesch, the Sigmund Freud Society has acquired a collection that demonstrates the influence of psychoanalysis on contemporary art. In 2003, under director Inge Scholz-Strasser—albeit against the wishes of many Viennese psychoanalysts—the museum turned into a private foundation. This event led to a noticeable coolness between the administration and the city's psychoanalytic societies.

AUGUST RUHS

### **Bibliography**

- Caruso, Igor A. (1964). *Existential psychology: from analysis to synthesis* (Eva Krapf, Trans.). New York: Herder and Herder. (Original work published 1952)
- Huber, Wolfgang. (1977). *Psychoanalyse in Österreich seit 1933*. Vienna: Geyer.
- Parth, Walter. (1998). Vergangenheit, die fortwirkt. *Texte: Psychoanalyse, Ästhetik, Kulturkritik*, 2, 61–75.
- Reichmayr, Johannes. (1994). *Spurensuche in der Geschichte der Psychoanalyse*. Frankfurt am Main: S. Fischer.

## **AUTISM**

Autism has had two meanings. The first, historically associated with schizophrenia, refers to the investment of a person's psychic energy in his or her own delusions, which prevents the person from investing in the outside world. The second refers to an absence of

development of communication with others beginning in earliest infancy.

The word was introduced into the psychiatric vocabulary by Eugen Bleuler in 1911 in his description of schizophrenia. However, a hint of it could be detected as early as 1907 in the correspondence between Freud and Jung: “Bleuler still misses a clear definition of autoerotism and its specifically psychological effects. He has, however, accepted the concept for his Dem[entia] pr[aecox] contribution to Aschaffenburg's Handbook. He doesn't want to say autoerotism (for reasons we all know), but prefers ‘autism’ or ‘ipsism’” (Freud and Jung, p. 44–45).

Bleuler, who very early on took an interest in Freud's work, did not accept his libido theory, and this was the reason for the amputation that produced the word *autism* from *autoerotism*: to distance it from the libidinal significations of the latter term, while keeping the former's Greek root, *auto*, meaning “self.” For Bleuler, the autism of schizophrenia is a shutting-in of the subject in an impenetrable, incommunicable world, closed in on itself, made up of unorganized delusional elements to which all the subject's disposable mental energy is attached.

In 1943, Leo Kanner adopted the term to describe “early infantile autism,” a syndrome associated with problems of communication and social behavior, as well as serious developmental disturbances of mental functioning, most notably of imagination

Psychoanalytic research bearing upon infantile autism led to significant advances in the understanding of the beginnings of psychic life. From the genetic point of view, for example, infantile autism corresponds to a stage of psychical development to which the child regresses or remains fixated. In research with normal infants after her initial studies of autistic children, Margaret Mahler placed autism on a developmental axis that progresses from birth to “separation-individuation.” Donald Winnicott attributed the genesis of autism to maternal care, particularly the ability to protect the infant from inconceivable anxieties: a feeling of disintegration, being unable to stop falling, lacking relation to its own body, and having no orientation. Bruno Bettelheim defined the “extreme situation” that set the baby on the path to becoming autistic as a feeling that it could not act in a manner favorable to itself, but that every action on its own part could only be unfavorable because of a “mutuality” between the child and its mother.

From the structural point of view, autism is governed by a structure that establishes mental functioning. The students of Jacques Lacan developed the concept in this direction by relating it sometimes to the concept of “foreclosure” (Piera Aulagnier and Maud Mannoni), sometimes to “jouissance” (Éric Laurent), and sometimes to the “topology of the subject” (Rosine and Robert Lefort).

From a dynamic point of view, it was possible to explore infantile autism in terms of the transference and counter-transference. In 1975, Donald Meltzer proposed a model articulated around three concepts: “the dismantling of the ego,” “the bidimensionality of the object relation,” and “the adhesive identification.” Dismantling is a splitting of the ego along the lines of articulation of the different sensorial modalities, so the autistic child never concentrates feelings on the same object, and stimuli received is never synthesized. The world, perceived in this way, is without depth or volume and is reduced to a juxtaposition of sensations. Bidimensionality is a mode of relation to a libidinal object, established in a world without depth. It is a relation of surface to surface, a binding with an object not experienced as having an interior. Adhesive identification is the result of bidimensionality: the self identifies itself with the object on the surface, owing to no more interior space than the object itself. This prevents mental communication necessary to the development of thought.

Later, Meltzer proposed a model based on the theory of “aesthetic conflict.” He suggested that the fetus, at the end of pregnancy, is eager to exercise its senses but receives only the most filtered stimuli *in utero*. Birth would be experienced as liberation and as something marvelous because of the abundance of sensorial stimulation. The impact would be experienced as an intense aesthetic experience that would at the same time be a source of anxiety because of the vivid contrast between the infant’s overabundant awareness of the qualities of the object’s surface and complete misrecognition of the object’s interior. Occasionally, the impact of the aesthetic object would be so intense as to force the infant to withdraw into infantile autism.

Frances Tustin has emphasized a fantasy of discontinuity, which the autistic infant experiences physically as the tearing away of a part of its own substance. So long as it lacks the experience that makes possible symbolization, an infant would seem to require the illusion of continuity between its body and the object upon

which its drives are satisfied. The autistic infant imagines a catastrophic rupture in this continuity that takes the form of a fantasy of mouth-tongue-nipple-breast, experiencing a damaged breast and torn-off nipple that leaves the mouth a black hole inhabited by tormenting objects. To protect itself from the pain caused by this black hole, the autistic infant constructs the delusion of merging with the environment that abolishes any separation or space, any difference or alterity. To maintain these delusionary autistic objects, concrete objects are not manipulated for use value or symbolic value, but solely for the surface sensations that they offer, giving the illusion of continuity between body and environment. By means of his or her own secretions (tears, saliva, urine, feces) and autistic objects, the subject creates what Tustin called “autistic forms,” which are cutaneous or mucous with nebulous, unstable contours. The autistic subject procures these as a salve to minimize pain and as protection from the exterior world. But these autistic forms cannot be shared with others or identified with objects in the external world. The autistic child uses sensitivity to stimuli to protect himself or herself from the external world; Frances Tustin calls this “perverse self-sensuality.”

DIDIER HOUZEL

*See also:* Adhesive identification; Autistic capsule/nucleus; Autistic defenses; Bettelheim, Bruno; Black hole; Bleuler, Paul Eugen; Child analysis; Developmental disorders; Dismantling; *Empty Fortress, The*; Infantile psychosis; Infantile schizophrenia; Psychoses, chronic and delusional; Schizophrenia; Self-mutilation in children; Symbiosis/Symbiotic relation; Tustin, Frances.

### **Bibliography**

- Freud, Sigmund, and Jung, Carl G. (1974a [1906–13]). *The Freud-Jung letters: the correspondence between Sigmund Freud and C. G. Jung* (William McGuire, Ed.; Ralph Manheim and R. F. C. Hull, Trans.). Princeton: Princeton University Press.
- Meltzer, Donald, and Williams, Meg Harris. (1988). *The apprehension of beauty*. Perth: Clunie Press.
- Meltzer, Donald, et al. (1975). *Explorations in autism*. Perth: Clunie Press.
- Tustin, Frances. (1977). *Autism and childhood psychosis*. London: Hogarth. (Originally published 1972)
- . (1981). *Autistic states in children*. London: Routledge.

**Further Reading**

- Gaddini, Renato. (1993). On autism. *Psychoanalytical Inquiry*, 13, 134–143.
- Gergely, G. (2000). Reapproaching Mahler: autism, symbiosis, splitting, libidinal object. *Journal of the American Psychoanalytic Association*, 48, 1197–1228.
- Guntrip, Harry. (1973). Science, psychodynamic reality, and autistic thinking. *Journal of the American Academy of Psychoanalysis*, 1, 3–22.
- Ogden, Thomas H. (1989). On the concept of an autistic-contiguous position. *International Journal of Psychoanalysis*, 70, 127–140.

**AUTISTIC CAPSULE/NUCLEUS**

The term “autistic capsule” (or “autistic nucleus”) was proposed by Frances Tustin to describe a split part of the personality that has encapsulated archaic depressive anxieties such as the fear of collapse, liquefaction, falling, a black hole, or amputation of a body part, within a system of autistic-like defenses. Sensation objects and sensation forms, experienced as part of the subject’s own body, serve to blot out bodily anxieties.

The notion of an autistic capsule appeared in Frances Tustin’s first book, *Autism and Childhood* (1972), in the chapter entitled “Systems of Pathological Autism,” where she refers to an “isolated pocket . . . of encapsulation” (p. 85). This construct enabled her to follow the development of a number of children who appeared normal but suffered from neurosis and later showed a variety of disorders: “phobias, sleeping difficulties, *anorexia nervosa*, elective mutism, some skin troubles, some psycho-somatic disorders, some learning difficulties, some speech disorders, and some forms of delinquency” (p. 85). She also argued that the autistic capsule exists “in the character structure of some relatively normal individuals,” as revealed by rigid splits, superficial identifications, and an exaggerated need for control (p. 85). The superficial aspect of autistic encapsulation, also developed by Donald Meltzer (1975) and related to the notion of adhesive identity described by Esther Bick (1986), has comparable aspects in the “as if” personality described by Helene Deutsch (1942) and the “false self” personalities described by Donald Winnicott (1965). Tustin thought that ultimately such autistic capsules exist in minimal form in all individuals and that they are responsible for regressive tendencies toward inertia,

similar to the regression toward an inanimate state associated with the death instinct in Freud’s theory. The “de-encapsulation” process, Tustin emphasized, is likely to give rise to manic-depressive swings.

In *Autistic Barriers in Neurotic Patients* (1986) and *The Protective Shell in Children and Adults* (1990), Tustin described the autistic capsule in neurotic adult patients in greater detail, using her own case histories, notably that of an anorexic adolescent girl. Her description of motifs of vampirism and a system of communicating vases is congruent with the findings of the French investigators Evelyne Kestemberg, Jean Kestemberg, and Simone Decobert in *La faim et le corps: une étude psychanalytique de l’anorexie mentale* (Hunger and the body: a psychoanalytic study of anorexia nervosa; 1972). This book also contains contributions from other psychoanalysts, notably Sydney Klein and David Rosenfeld, who developed the theme of autistic phenomena in their own work. Sydney Klein (1980) emphasized how autistic phenomena in neurotic patients lead to thinness and superficiality. Rosenfeld (1993) studied how certain types of drug dependency and psychosomatic illnesses have some autistic aspects.

GENEVIÈVE HAAG

*See also:* Autism; Autistic defenses; Breakdown; Black hole; Tustin, Frances.

**Bibliography**

- Bick, Esther. (1986). Further considerations on the functioning of skin in early object relations: findings from infant observation integrated into child and adult analysis. *British Journal of Psychotherapy*, 2, 292–299.
- Deutsch, Helene. (1942) Some forms of emotional disturbance and their relationship to schizophrenia. *Psychoanalytic Quarterly*, 11, 301–321
- Kestemberg, Evelyne; Kestemberg, Jean, and Decobert, Simone. (1972). *La faim et le corps: une étude psychanalytique de l’anorexie mentale*. Paris: Presses Universitaires de France.
- Klein, Sydney. (1980). Autistic phenomena in neurotic patients. *International Journal of Psycho-Analysis*, 61 (2), 395–401.
- Meltzer, Donald, Bremner, John, Hoxter, Shirley, Weddell, Doreen, and Wittenberg, Isca. (1975). *Explorations in autism*. Perth, Scotland: Clunie Press.
- Rosenfeld, David. (1993). Autisme: des aspects autistiques dans la pharmacodépendance et dans les maladies

psychosomatiques. *Journal de la psychanalyse de l'enfant*, 20, 168–188.

Tustin, Frances. (1972). *Autism and childhood psychosis*. London: Hogarth.

———. (1986). *Autistic barriers in neurotic patients*. London: Karnac Books.

———. (1990). *The protective shell in children and adults*. London: Karnac Books.

Winnicott, Donald W. (1965). Ego distortion in terms of true and false self. In his *Maturational processes and the facilitating environment* (pp. 140–152). London: Hogarth and the Institute of Psycho-Analysis. (Original work published 1962)

## AUTISTIC DEFENSES

The term “defense” is not generally associated with autistic states. However, manifestations of the “body ego” (Freud) that have as their function the avoidance of anxiety are “autistic defenses.” They give rise not only to “autistic phenomena” (“objects,” “gestures,” “languages,” etc.) that are inseparable from the sensations that they cause, but also to a devitalization of the outside world.

Leo Kanner (1943) is credited with the discovery of early childhood autism. Without explicitly using the term “defense,” he described a certain number of primary manifestations (sameness, self-sufficiency, self-absorption, and inaccessibility) that could be said to have a defensive function. In lieu of the term “autistic defense” (which implies a relatively organized ego), Margaret Mahler (1968) proposed the term “maintenance mechanism”; Frances Tustin, (1972, 1981) “autistic maneuvers”; and Fraiberg (1982) “defense reactions.” The autistic “defenses” are thought to result from the self-induced sensuality of the autist and his or her exclusive focus on bodily sensations and rhythms (Tustin). Frances Tustin spoke of “autistic objects,” “autistic contours,” and “encapsulation.” Donald Meltzer referred to “dismantling,” and Fraiberg to “avoidance” and to “freezing.”

The analysis of autistic “defenses” leads to that of the psychic function of the body ego on the border between somatic and mental.

ELSA SCHMID-KITSIKIS

## Bibliography

Fraiberg, Selma. (1982). Pathological defenses in infancy. *Psychoanalytic Quarterly*, 51 (4), 612–635.

Kanner, Leo. (1973). *Childhood psychosis, initial studies and new insights*. Washington, DC: Winston.

Mahler, Margaret. (1968). *On human symbiosis or the vicissitudes of individuation*. New York: International Universities Press.

Meltzer, Donald. (1975). Adhesive identification. *Contemporary Psycho-Analysis*, 11, 289–310.

Tustin, Frances. (1972). *Autism and childhood psychosis*. London: Hogarth.

———. (1981). *Autistic states in children*. London: Routledge.

## Further Reading

Cohen D. , and Jay, S. M. (1996). Autistic barriers in the psychoanalysis of borderline adults. *International Journal of Psychoanalysis*, 77, 913–934.

Gomberoff, M. and Gomberoff, L. (2000). Autistic devices in small children in mourning. *International Journal of Psychoanalysis*, 81, 907–920.

Kilchenstein, M., and Schuerholz, L. (1995). Autistic defenses and the impairment of cognitive development. *Bulletin of the Menninger Clinic*, 59, 443–459.

Mitrani, J. L. (1992). The survival function of autistic manoeuvres in adult patients. *International Journal of Psychoanalysis*, 73, 549–560.

## “AUTOBIOGRAPHICAL STUDY, AN”

Freud’s autobiography appeared in *Die Medizin der Gegenwart in Selbstdarstellungen* (Today’s medicine: autobiographies), published in Leipzig in 1925. In the introduction Freud recalls that in 1909 he had outlined the development of psychoanalysis at Clark University in Massachusetts and in 1914 published a history of the psychoanalytic movement (1914d). Realizing that his life history is part of the origins of psychoanalysis, Freud wrote, “I will have to try to find a new way of blending subjective and objective exposition, somewhere between biography and history.”

After a brief reference to his childhood, he directs his attention to a discussion of his teachers: Ernst Wilhelm von Brücke, Theodor Meynert, and especially Jean Martin Charcot. Considerable space is given to Josef Breuer and hypnosis, relatively little to Wilhelm Fliess.

The major discoveries—the concept of psychic reality, infantile sexuality, resistance, repression, dream interpretation—are described and condensed so he can focus on a discussion of psychoanalysis's relationship with other fields and, therefore, the history of the psychoanalytic movement and its conflicts (including his with Carl Gustav Jung). The end of the book is devoted to the applications of psychoanalysis: religion, ethnology, mythology, pedagogy, and so on, illustrating the importance Freud gave to this aspect of his theory.

The identification of Freud with psychoanalysis limits the field of historical investigation in terms of both Freud's biography and the history of psychoanalysis. However, this method of personal exposition is familiar to him and is, in the majority of his works, an intrinsic part of the theoretical exposition, if not an apodictic strategy. Following his break with Wilhelm Fliess, Freud was cautious about the charge of plagiarism and priority of discovery. It is possible to conclude that this point of view limits an understanding of the dialectics of influence, the recognition of cryptomnesia, and more generally the reliance on another's hypotheses to advance one's own.

The truth, as Freud wrote, is fragmentary, and historical narrative is more like a legend than a "family romance."

SOPHIE DE MIJOLLA-MELLOR

*See also:* Autobiography.

### Source Citation

Freud, Sigmund. (1925d [1924]). *Selbstdarstellung. Die Medizin der Gegenwart in Selbstdarstellungen*, 4, Leipzig, p. 1–52; *GW*, 14: 31–96; An autobiographical study. *SE*, 20: 7–70.

### Bibliography

Freud, Sigmund. (1914d). On the history of the psychoanalytic movement. *SE*, 14: 1–66.

Mijolla-Mellor, Sophie de. (1990). Autobiographie de la psychanalyse. *Le Coq-Héron*, 118, 6–14.

Rey, Jean-Michel. (1984). Freud et l'écriture de l'histoire. *L'Écrit du temps*, 6, 23–42.

---

## AUTOBIOGRAPHY

As a literary genre, autobiography, narrating the story of one's own life, is a variation of biography, a form of

writing that describes the life of a particular individual. From the point of view of psychoanalysis, autobiography is of interest as the story told by the patient to the analyst and to himself.

Autobiography in the modern sense began as a form of confession (Saint Augustine), even though there are memoirs in classical literature (Xenophon's *Anabasis*, Julius Caesar's *Gallic wars*). Such introspective works can be considered attempts at self-analysis before the psychoanalytic discovery of the unconscious. In 1925 Freud wrote *An Autobiographical Study*, in which the story of his own life merges with that of the creation of psychoanalysis. According to Freud, biographical truth does not exist, since the author must rely on lies, secrets, and hypocrisy (letter to Arnold Zweig dated May 31, 1939). The same is true of autobiography. From this point of view, it is interesting that Freud framed his theoretical victory and the birth of psychoanalysis in terms of a psychological novel.

The function of autobiography is to use scattered bits of memory to create the illusion of a sense of continuity that can hide the anxiety of the ephemeral, or even of the absence of the meaning of existence, from a purely narcissistic point of view. This story constitutes a narrative identity (Ricoeur, 1984–1988) but is self-contained. In contrast, the job of analysis is to modify, indeed to deconstruct, this identity through interpretation. Because the analyst reveals repressed content, he is always a potential spoiler of the patient's autobiographical story (Mijolla-Mellor, 1988).

Although autobiography has been of greater interest to literature (Lejeune, 1975) than to psychoanalysis, a number of psychoanalysts (Wilfred Bion and Marie Bonaparte, among others) have written autobiographies, thus confirming the link between the analyst's pursuit of self-analysis and autobiographical reflection.

SOPHIE DE MIJOLLA-MELLOR

*See also:* "Autobiographical Study, An"; Jung, Carl Gustav; Literature and psychoanalysis; "Psychoanalytic Notes on the Autobiography of a Case of Paranoia (*Dementia paranoides*)"; Memoirs of the future.

### Bibliography

Freud, Sigmund. (1925). An autobiographical study. *SE*, 20: 1–74.

Lejeune, Philippe. (1974). *Le pacte autobiographique*. Paris: Seuil.

Mijolla-Mellor, Sophie de. (1988). *Suivre à so passé*. In *L'autobiographie*. Paris: Les Belles Lettres.

———. (1990). *Autobiographie et psychanalyse*. *Le Coq-Héron*, 118, pp. 6–14.

Ricoeur, Paul. (1984–1988). *Time and narrative* (Kathleen McLaughlin and David Pellauer, Trans.). Chicago: University of Chicago Press. (Original work published 1985)

## AUTOEROTICISM

The term “autoeroticism” refers to behaviors designed to obtain sexual satisfaction without the intervention of another person (the most obvious example being masturbation). However, the term is often understood more broadly, given the Freudian conception of psychosexuality, according to which many different physical pleasures take on the value of sexual satisfaction. Genitals are not necessarily involved. By extension, the same can be said of certain psychic activities (reading, according to popular wisdom, is a “solitary vice”). “Alloeroticism,” a less common term, refers by contrast to sexual satisfaction obtained with the help of another person.

Sigmund Freud, who took the terms from Havelock Ellis, appears to have used them for the first time in a letter to Wilhelm Fliess, dated December 9, 1899: “The lowest sexual stratum is auto-erotism, which does without any psychosexual aim and demands only local feelings of satisfaction. It is succeeded by allo-erotism (homo- and hetero-erotism) but it certainly also continues to exist as a separate current” (Freud, 1950a, p. 280).

According to this initial definition, autoeroticism would appear first but would never disappear. Freud clarified his thought in *Three Essays on the Theory of Sexuality* (1905d) and then in later footnotes. He considered sucking to be a fundamental activity: “The child’s lips, in our view, behave like an erotogenic zone, and no doubt stimulation by the warm flow of milk is the cause of the pleasurable sensation. The satisfaction of the erotogenic zone is associated, in the first instance, with the satisfaction of the need for nourishment” (p. 182). In 1915 Freud added: “To begin with, sexual activity attaches itself to functions serving the purpose of self-preservation and does not become independent of them until later . . . The child does not make use of an extraneous body for his sucking, but prefers a part of his own skin because it is more convenient, because it makes him independent of the external world, which he is not yet able to control” (1905d, p. 182). This is one of Freud’s most

important claims—infantile sexuality develops by making use of a function essential for life, from which it later detaches itself.

This autoerotic satisfaction is not required for every object cathexis, however, since, through this detachment, the child frees itself from its first object, the breast, which is the vehicle of a hallucinatory satisfaction and the subsequent disappointment that leads to the birth of the first representations.

“On Narcissism; An Introduction” (1914c) enabled Freud to take this a step further. When the child constitutes itself as an “object” for its own satisfaction, it is no longer a question of drive satisfaction, as in autoerotic activity, located in a given erotogenic zone, but rather of the beginning of the unification of drive and object: “the hitherto dissociated sexual instincts come together into a single unity and cathect the ego as an object” (1912–13a, p. 89). This unifying movement then acts on another person during the initial “object choices” that will govern all later sexual life. Freud would later refine these views and provide an overview of the process in a 1923 article on infantile genital organization (1923e).

Autoeroticism, therefore, characterizes an early phase of psychosexual development. However, as Freud acknowledged in his 1899 letter to Fliess cited above, it continues to “subsist,” as many common clinical findings demonstrate. It also plays a major role in a number of disorders; in psychoses it can appear invasive (Gillibert, Jean, 1977), as shown in the case of Daniel Paul Schreber (Schreber, 1903/1988; Freud, 1911c), or deficient (Botella, César, and Sára, 1982). In this area as in so many others, the diagnostic dimension and the psychogenetic dimension are complementary.

ROGER PERRON

*See also:* Infant development; Narcissism; *Three Essays on the Theory of Sexuality*.

### Bibliography

Botella, César, and Botella, Sára. (1982). Sur la carence auto-érotique du paranoïaque. *Revue française de psychanalyse*, 46 (1), 63–80.

Freud, Sigmund. (1905d). Three essays on the theory of sexuality. *SE*, 7: 123–243.

———. (1912–13a). Totem and taboo. *SE*, 13: 1–161.

———. (1950a). Extracts from the Fliess papers. *SE*, 1: 173–280.



Gillibert, Jean. (1977). De l'autoérotisme. XXXVII Congrès des psychanalystes de langues romanes. *Revue française de psychanalyse*, 41, 5–6.

Schreber, Daniel Paul. (1988). *Memoirs of my nervous illness*. (I. Macalpine and R. Hunter, Trans.). Cambridge: Harvard University Press (Original work published 1903).

## AUTOHISTORIZATION

The *I* is constituted by the discourse it builds about itself, its self-assigned task being to transform the fragmentary elements of its past, whether they come from itself or from other people, into a historical construction. The difference between memory and history involves the sequencing of facts to meet two requirements: first of all, that of imparting a feeling of temporal continuity, and in addition, simultaneously, endowing this historical construction with a power of causal explanation with regard to the future (Mijolla-Mellor, Sophie de, 1998). The *I* thus figures, according to the title of Piera Aulagnier's *L'Apprenti historien et le maître sorcier* (The apprentice historian and the master sorcerer; 1984), as an "apprentice historian" faced with the "master sorcerer" constituted by the id.

Autohistorization is the only way the subject can grasp the notion of time, which can only make sense to the subject in relation to his or her own desires and self-perceptions: "The process of identification is the hidden side of the work of historicization that transforms the unfathomable entity of physical time into human time, that replaces irrevocably lost time with a time that speaks it," writes Aulagnier.

This history is that of the *I*'s relationship to its objects: a libidinal history, and a history that can only target the *I* indirectly, through the Other. From temporality to memory to history there occurs an unfolding movement, the construction that the *I* must effect in order for its existence to make sense.

In Aulagnier's view, we are "historians whose quest always founders on an 'already-there' about ourselves or others that resists our efforts to elucidate it." This human inevitability forces the *I* to take possession of this preexisting "elsewhere" and to include it within itself; to do this, the *I* must rely on the accounts of other people who provide it with an affirmation that what it is and what it was are identical, and at the same time give elements of information on this issue. This gives rise to the question of what happens when others fail to transmit to the subject the "first paragraphs" of an individual's personal history and prehistory.

In *L'Apprenti-historien et le maître sorcier*, Aulagnier develops the notion of "nonhistory" in the schizophrenic. In these cases, the mother exerts on the infant's psyche an action of repression so powerful that it will render impossible even the revealing of non-repressed material (and, as it happens, inculcate a desire for death as well) that is present and active within the mother's own psyche. Hence the attempted delusional reconstruction that would enable the subject to do without this contribution from the mother: "The fantasy of self-engenderment that is present in certain forms of psychosis can most often be decoded, on close inspection, as a fantasy that gives the subject the power to engender not just his or her own past, but all past, not just his or her own origins, but all origins."

Aulagnier's entire theory on psychosis, contrary to monolithic interpretations (such as foreclosure in the Name of the Father, double bind, and so on) reflects, as did Sigmund Freud's work, a perspective that is essentially historical, focusing on singular events. What she demonstrates here concerns the consequences of prohibition on memory, and thus the work of autohistorization without which the *I* cannot come into being.

SOPHIE DE MIJOLLA-MELLOR

See also: *Apprenti-historien et le maître sorcier (L)* [The apprentice historian and the master sorcerer]; Family romance; Psychic temporality.

## Bibliography

Aulagnier, Piera. (1984). *L'Apprenti-historien et le maître sorcier. Du discours identifiant au discours délirant*. Paris: Presses Universitaires de France.

Mijolla-Mellor, Sophie de. (1998). *Penser la psychose. Une lecture de l'oeuvre de Piera Aulagnier*. Paris: Dunod.

## AUTOMATISM

Properly speaking, "automatism" is not a concept, but rather a term that, like the adjective "automatic" or the adverb "automatically," has several definitions. It can mean "mental operations or activities without the involvement of the will, activities rendered automatic by habit, regularity in the completion of certain acts, or a set of involuntary activities or impulses" (Lantéri-Laura, 1992).

The term "automatism" refers to an activity carried out without the participation of the will. Once the

activity is triggered, it becomes a mechanism that functions by itself. This notion of automatism, derived from the philosophic and medical traditions, provided the eighteenth century with a model, though reductionist, for global and hegemonic knowledge of the physical and biological worlds and, in the biological world, for human behavior. (La Mettrie published *Man a Machine* in 1746.) Later, because of advances in chemistry that revealed very different levels of organization in the two worlds, the model of automatism seemed on the contrary to control only vegetative life, corresponding to the autonomic nervous system, and involved only one part of the life functions, that of muscular mechanics. In this era, a simultaneously morphological and functional opposition was conceived between a less automatic superior level and a more automatic inferior level.

From John Huglings Jackson's work on epilepsy in the nineteenth century emerged a highly elaborated representation of the function and dysfunction of the central nervous system and the discovery of a specific attack—related to lesions—on the automatisms in question. Thus a disorganization of a hierarchical structure suppressed a function and freed what the suppressed function had previously controlled—one automatism disappeared and the other remained uncontrolled.

This notion of an automatism proper to the functioning of the central nervous system found several examples in the field of psychiatry, for instance, the work of Valentin Magnan and his notion of impulse, that of Jules Seglas defining the relation between verbal hallucinations and aphasias, the psychological automatism of Pierre Janet, and finally the mental automatism of Georges de Clérambault and the work of Henri Ey, which was greatly influenced by John H. Jackson.

What is involved is a definition of automatism that situates it as mechanism that is “under control.” It becomes pathogenic and pathological as soon as such control ceases. Meanwhile, there emerges another definition of automatism that situates it instead on the side of the creative force, of a more lively and original inspiration.

The word *automatisch* appeared very rarely in Freud. In one of its earliest occurrences (the case of Dora, 1905e [1901]), it is apparent that he is borrowing vocabulary that is not his own: “I give the name of symptomatic acts to those acts which people perform, as we say, automatically, unconsciously, without attending to them, or as if in a moment of distraction” (p. 76). Then, in the metapsychological texts, the word

is used in three limited senses: a) the regulation of (unconscious) automatic processes by the pleasure principle (*Beyond the Pleasure Principle*, 1920g); b) so-called “automatic” anxiety when it is a question of the origin or the “automatic” appearance of anxiety (*Inhibitions, Symptoms, and Anxiety*, 1926d); and occasionally, c) the process of repression (1926d).

The noun *Automatismus*, “automatism,” is also very rarely found in Freud's works. When Freud refers to it in *Inhibition, Symptoms, and Anxiety* in relation to the process of repression, he prefers the term “compulsion to repeat”: “The new impulse will run its course under an automatic influence—or, as I should prefer to say, under the influence of the compulsion to repeat. It will follow the same path as the earlier repressed impulse, as if the danger-situation that had been overcome still existed” (p. 153). In the *New Introductory Lectures* (1933a [1932]), the term is directly connected to the principle of pleasure-unpleasure, in a sense essentially based on the (automatic) mode of regulation of unconscious processes, but that merges with anxiety and repression.

The term was used more frequently by Jacques Lacan, specifically starting in the fifties, when, under the influence of cybernetics, the question of automata was on his mind. And so pure automatism became an essentially psychotic phenomenon.

Today the term, still being enriched by new mathematical models, could clarify for us a certain mode of the functioning of mental processes.

PASCALE MICHON-RAFFAITIN

See also: Compulsion; Janet, Pierre; Letter, the; Repetition compulsion; Subconscious; Trauma.

### **Bibliography**

- Freud, Sigmund. (1905e [1901]). Fragment of an analysis of a case of hysteria. *SE*, 7: 1–122.
- . (1920g). Beyond the pleasure principle. *SE*, 18: 1–64.
- . (1926d). Inhibitions, symptoms, and anxiety. *SE*, 20: 75–172.
- . (1933a). New introductory lectures on psychoanalysis. *SE*, 22: 1–182.
- Lantéri-Laura, Georges. (1992). *Psychiatrie et connaissance*. Paris: Sciences en situation.
- La Mettrie, Julien Offray de. (1746). *Man a machine*. La Salle, IL: Open Court Classics, 1912.

## AUTOPLASTIC

The terms “autoplastic” and “alloplastic” serve to distinguish changes internal to the subject from work carried out on the external world. Sándor Ferenczi proposed the word “autoplastic” in an article on hysterical materialization (1919/1926). Citing Freud’s description of hysteria as a caricature of art, Ferenczi added, “Hysterical ‘materializations’ . . . show us the organism in its entire plasticity, indeed in its preparedness for art. . . . The purely ‘autoplastic’ tricks of the hysteric [may well be] prototypes, not only for the bodily performances of ‘artists’ and actors, but also for the work of those creative artists who no longer manipulate their own bodies but material from the external world” (p. 104).

Freud adopted these terms when clarifying the similarities and the differences between neurosis and psychosis (1924e). “Expedient, normal” behavior, he wrote, combines features of both disorders, for it “disavows the reality as little as does a neurosis, but . . . then exerts itself, as does a psychosis, to effect an alteration of that reality.” But it “does not stop, as in psychosis, at effecting internal changes. It is no longer *autoplastic* or *alloplastic*” (p. 185).

These seldom used notions might arguably serve a useful purpose in describing the analytic process: in their asymmetrical way, the two protagonists in treatment are engaged in an unending struggle between changing the other and effecting internal change.

STEVEN WAINRIB

*See also:* Hysteria.

### Bibliography

- Freud, Sigmund. (1924e). The loss of reality in neurosis and psychosis. *SE*, 19: 180–187.
- Ferenczi, Sándor. (1926). The phenomena of hysterical materialization: thoughts on the conception of hysterical conversion and symbolism. In his *Further contributions to the theory and technique of psycho-analysis*. London: Hogarth Press. (Original work published 1919)

## AUTOSUGGESTION

Autosuggestion was popularized by the French “Nancy school.” By the first half of the nineteenth century, methods of self-medication and self-healing known as

“automagnetization” had reinforced (or supplanted) various forms of “magnetism.”

At the end of the century, a theoretical and practical debate ensued that both galvanized and divided the various schools of hypnotism. What was the real agent in the process of suggestion: the hypnotist, or the subject, who often relinquishes power to him without realizing it? For those who believed the latter, the effectiveness of the suggestion was thought to depend on a self-suggestibility associated with hysterical tendencies (Jean Martin Charcot, Pierre Janet), or the “will” of the subject (a position put forward by Joseph Delboeuf [1831–1896], an independent disciple of Hippolyte Bernheim). In 1888–1889, basing his theory on the work of Charcot, Freud showed that some suggestive experiences could be interpreted in terms of an “encouragement to autosuggestion.” In 1892–93, he proposed the notion of a “counter-will.” In 1895 Joseph Breuer insisted that self-hypnotic states were a symptom of hysteria and a process of self-medication and self-healing carried out in the presence of the therapist. The cathartic *talking cure* occurred during these states of self-hypnosis.

Following in the tradition of Nancy school, the pharmacist Émile Coué (1857–1926) popularized the use of autosuggestion to govern one’s own behavior. His disciple Charles Baudouin suggested that a synthesis be attempted between Coué’s theories and psychoanalysis.

JACQUELINE CARROY

*See also:* Baudouin, Charles; *Qu’est-ce que la suggestion?* (What is the suggestion?); Suggestion.

### Bibliography

- Cuvelier, André. (1987). *Hypnose et suggestion: De Liébeault à Coué*. Nancy, France: Presses Universitaires de Nancy.
- Delboeuf, Joseph. (1993). *Le sommeil et les Rêves et autres textes*. Paris: Fayard. (Originally published in 1885)
- Duyckaerts, François. (1992). *Joseph Delboeuf, philosophe et hypnotiseur*. Paris: Synthélabo.
- Freud, Sigmund. (1888–1889a). Preface to the translation of Bernheim’s *Suggestion*. *SE*: 1: 71–85.
- . (1892–1893a). A case of successful treatment by hypnotism. *SE*: 1: 115–128.

# B B

## **BACHELARD, GASTON (1884–1962)**

Gaston Bachelard, a French philosopher, was born on June 27, 1884, in Bar-sur-Aube and died in Paris on October 16, 1962. He held a Ph.D. in philosophy and was a member of the Académie des Sciences Morales et Politiques. His career was far from ordinary. He was born into a family of modest means and began his professional life as a temporary employee in the postal service. In 1919 he became a teacher of physics and chemistry at the Bar-sur-Aube grammar school and prepared for his degree in philosophy, which he obtained in 1922. In 1927 he defended his doctoral dissertation and was appointed a professor of philosophy in 1930 at the University of Dijon and later at the Sorbonne (1940–1955). He received the Grand Prix National des Lettres in 1961.

His work is divided between considerations of the scientific mind, rationalism and the need for truth, and reflections on the imagination, daydreams, and poetry. Psychoanalysis, as Bachelard understood it, could serve as a link between these two approaches and, at times, there are echoes of a Jungian approach in his work.

In 1938 he produced *La Formation de l'esprit scientifique: Contribution à une psychanalyse de la connaissance objective* and *The Psychoanalysis of Fire*. The word psychoanalysis was pivotal; the study of fire paved the way for a discussion of the epistemological problem of heat and thermodynamics. Bachelard introduced a powerful and disturbing poetics. For him the scientific mind's idea of the unconscious could be understood not on the basis of dreams but of reverie, that is, fantasies organized into complexes. By grasping the link between electrical fire and sexual fire,

he develops the idea that dream-like values are an obstacle to true understanding and that it is necessary to engage in repression, a voluntary intellectual act of inhibition, which brings with it resistance, defense, and rupture. Psychoanalysis serves as a source of inspiration, it enables us to understand the formation of the scientific mind as an activity that is always subject to revision, not by a purely logical subject but by a superego animated by a rationalist tension that makes sublimation a positive and necessary factor and, in contrast to Freud, one that is also a joyful activity.

In working to frame Freudian concepts within a dialectic structure, Bachelard attempted to substitute a fecund surveillance of the mind for a repetitive and neurotic censorship. He was thus led to distinguish two types of knowledge: common knowledge and scientific knowledge, which consists in the repression of the former. For Bachelard, psychic conflict and resistance were ideas that could be used to conceive of truth as an error that has been rectified.

Bachelard's work found an echo in both the philosophy of the sciences and in literary criticism. But it is to Jacques Lacan that we must turn to fully assess what Bachelard attempted to introduce: the idea of a science whose subject is science.

ROGER BRUYERON

*See also:* France.

### ***Bibliography***

Bachelard, Gaston. (1964). *The psychoanalysis of fire* (Alan C. M. Ross, Trans.). Boston: Beacon Press. (Original work published in 1938)

———. (1968). *The philosophy of no; a philosophy of the new scientific mind* (G. C. Waterston, Trans.). New York: Orion Press. (Original work published in 1940)

———. (1969). *The flame of a candle* (Joni Caldwell, Trans.). Dallas, TX: Dallas Institute Publications, c1988.

———. (1972). *L'Engagement rationaliste*. Paris: Presses Universitaires de France.

## BAGINSKY, ADOLF (1843–1918)

Adolf Baginsky, a German pediatrician, was born May 22, 1843, in Ratibor (formerly in Upper Silesia, modern-day Poland) and died May 15, 1918, in Berlin. Baginsky came from a large family of Jewish shopkeepers. He studied medicine in Berlin and Vienna, and obtained his diploma in Berlin on May 7, 1866. His dissertation was on the risks of cesarean birth. He specialized in pediatrics and, in 1872, settled in Berlin as director of a free clinic for children, the Johannisstrasse. In 1877 he founded the *Central-Zeitung für Kinderheilkunde* (Central Journal of Pediatrics), which, in 1879, became the *Archiv für Kinderheilkunde* (Archives of Pediatrics).

He was assigned to a teaching position in 1882 after publishing a work on pediatrics as an autonomous specialization, but, outside of a few courses on pediatrics given during his vacations, his university position was precarious. Cofounder and, after 1890, director of the Kaiser- und Kaiserin-Friedrich-Kinderkrankenhaus (The Emperor and Emperess Friedrich Pediatric Hospital) in Berlin-Wedding, which he ran until April 1, 1898, he was named associate professor in 1892, then held the chair in 1907.

Following a period of study in Paris, Sigmund Freud spent the month of March 1886 at the Baginsky clinic, where he acquired a good understanding of children's diseases in order to prepare for his work as "sector head" in the first public institution for childhood diseases in Vienna.

Baginsky's work is extremely varied, ranging from medical care for sick children to initiatives for socio-medical prevention (including open air schools, educational medicine, and milk distribution). His work bears the mark of a profound humanitarian ideal. Although his religious beliefs became an obstacle to his academic career, he remained actively engaged in the Jewish community. His research reflects all the

richness of his various activities; as an editor he was especially attentive to the psychic disturbances of childhood.

JOHANN GEORG REICHENEDER

See also: Institut Max-Kassowitz.

### Bibliography

Bonomi, C. (1994). Why have we ignored Freud the "Paediatrician?" *Cahiers psychiatriques genevois*, Special Issue, 55–99.

Reicheneder, J. G. (1994). Freud in Berlin 1886. *Luzifer-Amor*, 7, 7–16.

Schlossmann, A. (1919). Nachruf auf Adolf Baginsky. *Arch. Kinderheilkunde*, 67, 1–6.

Zlocisti, T. (1913). Adolf Baginsky. *Ost und West*. 561–564.

## BAK, ROBERT C. (1908–1974)

Robert C. Bak was a psychiatrist and psychoanalyst, born in Budapest, October 14, 1908, and died in New York, September 15, 1974. Bak was the third son of a rich Jewish family. His father was a farm manager. After graduation in a high school of science, Bak enrolled in the medical university, and received his degree in 1933.

He was trained in psychoanalysis by Imre Hermann. Following his emigration from Budapest to New York in 1941, he worked as a psychiatrist and psychoanalyst. In 1947 he became a training analyst and soon after a leading figure of the New York Psychoanalytical Institute. He conducted courses and seminars.

In 1959 he became president of the Study Committee. He was president of the New York Psychoanalytical Society from 1957 to 1959, and guest-professor at the Albert Einstein Medical University. He conducted lecture tours in Italy, Denmark, and Switzerland for several years.

His early publications fuse psychoanalytical theory with the contemporary concept of psychiatry. He treated the great Hungarian poet Attila József for schizophrenia. The afterlife of the communist poet and of the young psychiatrist who had emigrated to the United States became closely intertwined in the ensuing fifty years of Hungarian psychoanalysis, in which Bak played a salient role, not exempt from ideological

distortions. He wrote several articles on the poet's pathology. In his last paper (1973) he again analyzed the poet's suicide from the point of view of his "progressive withdrawal from the object and repeated attempts to reestablish and recathect objects by being in love."

He maintained professional contact with Imre Hermann until his death, but he was also influenced by Heinz Hartmann's theory, and worked together with Phyllis Greenacre, Edith Jacobson, and Margaret Mahler. From the beginning he was engrossed in an in-depth exploration of the psyche through the phenomenology of psychopathology and the reality distortions manifest in psychoses and perversions. He pointed out the significance of early heat-orientation in schizophrenic symptom-formation. In addition to sadomasochistic libido, he also showed the presence of an overt and neutralized form of the aggression instinct in paranoia and perversions (1956). He traced the common origin of perversion fantasies back to phallic mother-image, and, in addition to the destabilization of reality, assigned an important role to the giant mother-image that Hermann had assumed for him (1968). He wrote about 25 studies in Hungarian, German, and English.

His work continues to exert a profound influence on the study of psychoses and perversion, and represents the traditions of the Hungarian school.

#### HUNGARIAN GROUP

See also: Hungarian School.

#### Bibliography

- Bak, Robert. (1941). Temperamentur-Orientierung und Überfließen der Ichgrenzen in der Schizophrenie. *Schweizer Archiv für Neurologie, Neurochirurgie und Psychiatrie*, 46, 158–177.
- . (1953). Fetishism. *Journal of the American Psychoanalytical Association*, 1–2, 285–297.
- . Aggression and perversion. In Sándor Lorand (Ed.), *Perversions: psychodynamics and therapy* (pp. 231–240). New York: Random House, 1956.
- . (1968). The phallic woman: The ubiquitous fantasy. *Psychoanalytic Study of the Child*, 23, 16–36.
- . (1973). Being in love and object loss. *International Journal of Psycho-Analysis*, 54, 1–8.

## BALINT GROUP

The Balint group is a group method of training doctors, generalists or specialists, in the doctor-patient relationship. This method was developed by Michael Balint and Enid Albu starting in 1945.

A dozen practitioners are brought together once a week for two hours under the direction of one or two analysts who receive honoraria and ensure the rules under which the group functions. A doctor reports, as spontaneously as possible, a case from his practice that poses a problem. Participants and leaders then help the presenter, by means associations, questions, and interpretations, to elucidate the difficulties in the presenter's relation with the patient.

The aim is to sensitize the doctor to transference and counter-transference in the "retroactive action" of the consultation, to give the doctor psychotherapeutic qualities, and thus to achieve a "considerable though limited change in the doctor's personality" to enable the doctor to better understand and help patients (Balint, 1957, p. 121).

Between 1949 and 1954 Balint and Albu elaborated and tested the method, by trial and error and by reminiscences, at the Tavistock Clinic in London, after Balint took up the Family Discussion Bureau seminar directed by Enid Albu (whom he would later marry). This seminar of case discussions trained social workers treating cases of marital problems. To define the link between client and social worker, Balint modified the case presentations, doing away with written and read reports in favor of oral presentations without notes, in order to maximize the conditions for counter-transference. This method, applying the fundamental rule, but always referred to a third party (the patient), was similar to Hungarian supervised analysis, centered on counter-transference.

The results were so impressive that when the National Health Service wanted to give doctors training in psychology, Michael Balint proposed the "Tavistock Method." Tested from 1950 to 1953, with volunteers recruited by *The Lancet*, it became a training and research method. French analysts who went to London to be trained soon renamed it the "Balint group."

The Balint movement, launched in the 1960s, is organized on the institutional level. Several national associations have been created: The Balint Medical Society of France (1967), The Balint Society of Great

Britain (1969), and others in over twenty countries, including Italy (1974), Germany, Belgium, and Russia (1994). On the international level, the European Council recognized the Balint Federation as a nongovernmental agency. As of 2004, the work of the Balints continued, with training in Balint groups, colloquia, and national and international conferences.

MICHELLE MOREAU RICAUD

See also: Hungarian School; Main, Thomas Forrest; Raimbault, Émile.

### **Bibliography**

- Balint, Michael. (1957). *The doctor, his patient, and the illness*. New York: International Universities Press.
- Balint, Michael, and Balint, Enid. (1961). *Psychotherapeutic techniques in medicine*. London: Tavistock.
- Balint, Michael, Balint, Enid, Gosling, Robert, and Hildebrand, H. Peter. (1979). *Le médecin en formation: La sélection et l'évaluation des résultats dans un programme de formation destiné à des médecins de famille*. Paris: Payot. (Original work published 1966)
- Moreau Ricaud, Michelle (2000). *Michael Balint: Le renouveau de l'école de Budapest*. Toulouse, France: Érès.

## **BALINT, MICHAEL (BÁLINT [BERGSMANN], MIHÁLY) (1896–1970)**

Hungarian physician and analyst Michael Balint was born in Budapest on December 3, 1896, and died in London on December 31, 1970.

He was the son of a Jewish general practitioner (Dr. Bergsmann) from a Budapest suburb. In the course of his brilliant university career (he earned qualifications in neuropsychiatry, philosophy, chemistry, physics, and biology), he met Alice Székely-Kovács, an anthropology student, who became his wife in 1924.

After World War I, he held various positions in Budapest, and then in 1921, left for Berlin to undergo analysis with Hanns Sachs at the same time as Alice. He occupied various positions in the Psychoanalytic Institute, the Institute for Organic Chemistry of the Royal Academy of Berlin, as well as the Charité Hospital medical clinic. It was towards the end of his twenties, with the aim of better integrating in society, that he changed his name from the Jewish-sounding

Bergsmann to the more “Hungarian” Balint, just as Sándor Ferenczi’s father (born Fraenkel) had done.

Dissatisfied with their analyses with Hanns Sachs, the Bálints returned to Budapest to finish with Sándor Ferenczi. Michael Balint subsequently became Ferenczi’s student, friend, and successor, as well as his literary executor. In 1931, he was made deputy director of the Psychoanalytic Polyclinic in Budapest under Ferenczi, becoming its director after Ferenczi’s death.

In January 1939, under the pressure of anti-Semitism, the Bálints emigrated to Manchester, England. Six months after their arrival, Alice Balint died. During World War II, Bálint taught medicine and science and began a private practice in psychoanalysis. From 1942–1945, he directed the Centers for Child Guidance in North East Lancaster and Preston. From 1942–1945, he was an honorary psychiatry consultant at Manchester Northern Hospital, and in 1945, psychiatrist at the Center for Child Guidance in Chiselhurst, Kent.

That same year, he set himself up in London as an analyst. There he again took up his project of placing psychoanalysis in the service of general practitioners, this time in collaboration with Enid Albu (herself an analyst), whom he married in 1950. From 1950–1953, he was the scientific secretary of the British Psychoanalytic Society. An admired teacher and supervising analyst, he employed the Hungarian method of training, that is, he himself supervised the first case of candidates he had analyzed. From 1950–1961, he was a psychiatric consultant at the Tavistock Clinic, and from 1957, a visiting professor of psychiatry at the University College of Cincinnati in the United States. From 1961–1965, he was honorary assistant to the department of psychological medicine at the University College Hospital in London where he directed post-graduate training seminars. In 1968, he was elected president of the British Psychoanalytic Society.

Balint’s psychoanalytic writings possess a remarkable coherence. He progressively developed his ideas from 1924 until they reached their ultimate form in his last work *The Basic Fault* (1968). In addition to the notion of the basic fault, Balint also introduced the concepts of primary love (1930–1935) in *Primary Love and Psychoanalytic Technique* (1952), and of benign and malignant regression in *Thrills and Regressions* (1959). He questioned the existence of primary narcissism and emphasized the contradictions in Freud’s

elaborations on it (“Critical Notes on the Theory of the Preenatal Organization of the Libido,” 1935). He coined the term “ocnophile” to describe personalities that feel the need to cling to objects and the term “philobatism” to characterize those who dread obstacles and seek out open spaces that are free of them (1959). He distinguished three mental zones: the oedipal zone, involving three persons, where conventional language holds sway; the zone of the basic fault, involving two persons, where conventional language is no longer current; and the zone of creation, where the subject is alone and creates only out of the self (1968).

Balint’s other major effort was his educational training work with general practitioners. His first article dealing with this subject dates from 1926: “On the Psychotherapies, for the Practicing Physician” (*Therapia* 5, Budapest). His major work in this area is *The Doctor, His Patient and the Illness* (1955).

The theoretical work of Michael Balint stands in direct relation to the clinic and constitutes a remarkable tool for psychoanalytic practitioners. The technique that he elaborated for use by general practitioners resulted in the creation of “Balint Groups” and “Balint Societies” that utilize this mode of training.

Finally, Balint is responsible for the preservation and promotion of the work of Sándor Ferenczi, for whom he was literary executor. It was Balint who transcribed Ferenczi’s Clinical Diary, which he then translated into English, and who also made the first transcription, during the 1950s, of Ferenczi’s correspondence with Freud.

Michael Balint published ten books (of which five were coauthored) and 165 articles. The Balint Archives are housed in the department of psychiatry in the University of Geneva.

JUDITH DUPONT

*Notions developed:* Basic fault; Benign/malignant regression; Primary love.

*See also:* Balint group; Balint-Szekely-Kovács, Alice; Ego-libido/object-libido; Great Britain; Hungarian School; Hungary; Medicine and psychoanalysis; Tavistock Clinic.

### **Bibliography**

Balint, Michael. (1964). *The doctor, his patient and the illness* (2nd ed.). London: Pitman Medical Publishing.

———. (1968). *The basic fault: therapeutic aspects of regression*. London: Tavistock Publications.

Faure, Franck. (1978). *La doctrine de Michael Balint*. Paris: Payot.

Haynal, André. (1988). *The technique at issue: Controversies in psychoanalysis: From Freud and Ferenczi to Michael Balint*. London: Karnac.

Moreau Ricaud, Michelle. (2000). *Michael Balint: Le renouveau de l’École de Budapest*. Paris: Erès.

## **BALINT-SZÉKELY-KOVÁCS, ALICE (1898–1939)**

Hungarian psychoanalyst and anthropologist Alice Balint-Székely-Kovács was born in Budapest on June 16, 1898, and died in Manchester on August 19, 1939.

She was the eldest daughter of Vilma Kovács, herself an analyst and student of Sándor Ferenczi. Both Alice and Michael Balint were also his students. Alice Balint had a brilliant career as a student in Budapest. One of her classmates was Margrit Schönberger, who became well known under the name of Margaret Mahler. Then she pursued university studies in mathematics and anthropology.

From 1921 to 1924, she resided in Berlin with Michael Balint, her future husband. Both were in analysis with Hanns Sachs and participated in the activities of the Psychoanalytic Association of Berlin. Dissatisfied with their analyses, they returned to Budapest and finished their training with Sándor Ferenczi.

Alice Balint was very active in the Psychoanalytic Association of Budapest. A child analyst at the Psychoanalytic Polyclinic of Budapest, she also maintained a private practice of children and adults. She gave lectures for parents that later appeared in the pedagogy journal *Gyermeknevelés* (Child Education). In 1939 the Balint family emigrated to Great Britain and established themselves in Manchester. Alice Balint died there suddenly at the end of August 1939.

Her work comprises a series of articles and one book. Her articles deal with ethno-psychoanalysis (“Mexican War Hieroglyphs,” “The Father of the Family”), psychoanalytic theory (“Love for the Mother and Mother Love,” “On Repression”) and pedagogy. Her book, called *A Gyermekszoba pszichológiája* (The Psychoanalysis of the Nursery), was translated into several languages.



Alice Balint died too young, leaving behind a body of work qualitatively modest, but of great originality, that still waits to be better known and used.

JUDITH DUPONT

*See also:* Balint, Michael; Hungary; Primary love.

### **Bibliography**

Balint, Alice. (1953). *The psycho-analysis of the nursery*. London: Routledge and Kegan Paul.

———. (1965) Love for the mother and Mother Love. In Michael Balint, *Primary love and psycho-analytic technique*. London: Tavistock Publications.

———. (1990). *Anya és gyermek (Mother and child)* (2nd ed.). Budapest: Pantheon.

---

## **BARANGER, WILLY (1922–1994)**

A psychoanalyst with a degree in philosophy, Willy Baranger was born on August 13, 1922, in Bône, Algeria, and died on October 29, 1994, in Buenos Aires.

He spent his childhood in Paris, where he continued his studies until he obtained his baccalaureate diploma in 1939. After moving to Toulouse because of the war, he completed his education with the PCB and received a degree in philosophy. He married Madeleine Coldefy and prepared for his doctorate in philosophy, which he received in 1945.

After teaching in France for a year, he left for Buenos Aires as a professor of philosophy at the Institut Français d'Études Supérieures. He began his psychoanalysis with Enrique Pichon-Rivière and soon completed his theoretical and practical training. In December 1954 a group of Uruguayan doctors and psychologists asked him to assume responsibility for training analysis and teaching in Montevideo. The Asociación Psicoanalítica del Uruguay was officially formed on September 27, 1955. It was recognized as a study group at the international congress held in Paris in 1957 and as an affiliate of the International Psychoanalytic Association at the congress of Edinburgh in 1961.

The *Revista uruguaya de psicoanálisis*, which is still in print, published its first issue in May 1956. Willy Baranger was a constant presence at the Latin

American congresses of psychoanalysis since their inception in Buenos Aires in 1956 and, in 1960, at the congress held in Santiago, Chile, he worked with his colleagues to create COPAL, the Coordinating Committee for Latin American Psychoanalytic Organizations, of which he was president in 1975–1976. In 1966 Baranger returned to Buenos Aires, where he resumed his teaching activities. He was part of the sponsorship committee of the Peruvian group that, once recognized as an affiliate of the International Psychoanalytic Association, named him an honorary member. In December 1993 he received the Mary S. Sigourney prize.

Baranger published four books: *Problemas del campo psicoanalítico*, with Madeleine Baranger (1969), *Posición y objeto en la obra de Melanie Klein* (1971), *Aportaciones al concepto de objeto en psicoanálisis* (1980), and *Artesanías psicoanalíticas* (1994).

Some of his many articles touch upon literature and philosophy. His work on epistemology defends the idea that psychoanalysis must formulate its own criteria of validation, different from those used by the exact sciences. He also studied the problem of ideology and its relation to idealized objects. His emphasis on the object is expressed in his *Posición y objeto en la obra de Melanie Klein*. This “objectology” depends on the willingness to structure any theoretical elaboration of the psychoanalytic situation as a fundamental given. The concept of the psychoanalytic situation as a “dynamic field” leads to an unconscious bipersonal fantasy of the session, in which transference and countertransference are extracted from a situation that possesses its own dynamism and outcomes, aside from the specific contributions of the analyst and analysand. For example, a “bastion” is a resistance produced in the psychoanalytic field by the unconscious collusion of the analyst and the analysand, which immobilizes the process.

Willy Baranger’s work is generally well known and recognized in Latin America, but much less so in Europe, with the exception of Italy, where a selection of his work was published in 1990 as *La situazione psicoanalitica come campo bipersonale* (The Psychoanalytic Situation as a Bipersonal Field).

MADELEINE BARANGER

*See also:* Argentina; Federación psicoanalítica de América Latina; Uruguay.

### Bibliography

Baranger, Madeleine, Baranger, Willy, and Mom, Jorge. (1983). Process and non-process in analytic work. *International Journal of Psycho-Analysis*, 64, 1–15. (Original work published 1982)

Baranger, Willy. (1971). *Posición y objeto en la obra de Melanie Klein*. Buenos Aires: Kargieman.

Baranger, Willy, and Baranger, Madeleine. (1969). *Problemas del campo psicoanalítico*. Buenos Aires: Kargieman.

---

### BASIC ASSUMPTION

Wilfred R. Bion (1961) uses the term *basic assumption* to designate that which, fundamentally, the individual must assume in order to be part of a group. Basic assumptions come into play at the unconscious, pathic, and affective levels.

Competing with the model of the work (*W*) group, which is focused on a task and puts into effect the secondary processes of rational thought and “reality-testing,” group activity is based on three basic assumptions that are discernible in the affective tone of the relations of group members among themselves and with their leader. The basic assumption of dependency (*baD*) lends cohesion to the group by means of supporting the assumption that nourishment, protection, knowledge, and life can come only from the wisdom of a leader who is omnipotent and omniscient, akin to a magician. The basic assumption of fight/flight (*baF*) brings individuals together around the violent, excitation-saturated feeling that the salvation of the group and its individual members depends on the fact that their leader will enable them to identify, and then successfully fight or flee, a specific enemy either within or outside the group. The basic assumption of pairing (*baP*) enables the group to come together as such through the members’ sharing of an implicit, mysterious hope, sparked by the assumption that a couple will give birth to a messiah, a new guide, a new idea, or a new theory or ideology.

These basic assumptions are states of mind—all of them sexual in the final analysis—associated with the characters in the oedipal situation (including the Sphinx); they emerge as secondary formations from an extremely primitive scene that is played out at the level of part-objects, and which is associated with psychotic anxieties and with the mechanisms of splitting and projective identification inherent in the

schizoid-paranoid and depressive positions posited by Melanie Klein.

BERNARD DEFONTAINE

See also: Bion, Wilfred Ruprecht; Group analysis.

### Bibliography

Bion, Wilfred R. (1961). *Experiences in groups*. London: Tavistock Publications.

Freud, Sigmund. (1921c). Group psychology and the analysis of the ego. *SE*, 18: 65–143.

Grinberg, León, Sor, Dario, and Tabak de Bianchedi, Elizabeth. (1977). *Introduction to the work of Bion: groups, knowledge, psychosis, thought, transformations, psychoanalytic practice* (Alberto Hahn, Trans.). New York: J. Aronson. (Original work published 1973)

Klein, Melanie. (1946). Notes on some schizoid mechanisms. *International Journal of Psycho-Analysis*, 27, 99–110.

Pines, Malcolm (Ed.). (1985). *Bion and group psychotherapy*. London: Routledge.

---

### BASIC FAULT

The term *basic fault* refers to the structural deficiency in the personality of subjects who during their early stages of development formed certain types of object relations—which later become compulsions—to cope with a considerable initial “lack of adjustment” between their psychobiological needs and the care provided by a “faulty” environment devoid of understanding. The effects of the basic fault on a person’s character structure and “psychobiological dispositions” (which may predispose that person to certain illnesses) are only partially reversible.

Michael Balint developed this concept in *The Doctor, the Patient, and the Illness* (1957), as a result of his research with physicians in the area of psychosomatic disorders. Additionally, in “The Three Areas of the Mind” (1958), Balint developed the notion of the “basic fault zone” to situate therapeutic processes relating to states of regression in certain patients. This became the source for his metapsychological theorization, in *The Basic Fault: Therapeutic Aspects of Regression* (1968), of “zones of the psychic apparatus,” which included a critique of Sigmund Freud’s notion of “primary narcissism” and new considerations on the handling of regression.

Certain patients (those with schizoid personalities, narcissistic states, or addictions, for example) are unable to tolerate the frustrations of classical treatment and are largely inaccessible to interpretation. The therapeutic relationship thus requires modifications in technique to open up to analysis the interpersonal psychic processes inherent in the “basic fault zone.”

This “zone” of the human psyche (which may be the ego) is unquestionably more primitive than both the “area of the Oedipus conflict” (Balint, 1968, p. 28) (prevalent in classical treatment) and the “area of creation” (p. 29). The processes that take place there are characterized by:

1. An exclusively “two-person” relationship, where only the patient’s needs count;
2. A dynamic force other than conflict (proper to the oedipal zone): that of an anxiety that drives the patient to perpetuate old models of object relations that now indicate maladjustment, such as behaviors that are “ocnophilic” (desperately clinging to objects) or “philobatic” (attempts at self-sufficiency by keeping well away from supposedly dangerous objects); this dynamic also drives the patient to establish a harmonious relationship with his or her environment (“primary love”);
3. The prevalence of nonverbal processes or language usage that is nontypical of adults.

A kind of “psychological mothering” makes it possible to avoid reproducing the traumatic situation in treatment; object relations, rather than interpretation, provide the therapeutic leverage. Regression, which is in part linked to the analyst’s responses, can be therapeutic (“benign”) if it is aimed at producing recognition of previously unacknowledged needs rather than satisfying them. Certain soothing forms of satisfaction (libidinal and physical contact) help sustain the therapeutic relationship. Reestablishing the primary love relationship allows the basic fault, once it has been recognized, to heal. It is said to be “neutralized” when the patient can let go of his or her compulsive object relations.

This theoretical model is especially relevant to the treatment of borderline cases; it is used in the framework of focal therapies and in situations addressing combined psychological, medical, and social considerations (psychotherapeutic aspects of medical treatment,

family planning consultations, and other such contexts). It sustains the fundamental metapsychological and clinical issues.

Inseparable from a conception of the psyche as a product of interpersonal relations—in particular, the ego as a “corporeal entity” (Freud)—and from a theory of treatment that makes use of regression, the “basic fault” has been subject to the criticisms that are usually made against any approach that aims at partial reparation: the risk of erotization, the risk of nondissolution of the transference, and so on. Balint viewed such criticisms as manifestations of anxiety on the part of analysts. Subsequent work has indicated that this conception of an early distortion in the ego should also take into account the pathogenic processes stemming from the patient’s family and cultural contexts. Focus on the nonverbal should not allow the underestimation of the crucial role that language and signifiers (just as much as their deficiencies or dysfunctions) play in the constitution of the ego.

CORINNE DAUBIGNY

See also: Balint, Michael; Benign/malignant regression; Hungarian School; Libido; Primary love.

### **Bibliography**

- Balint, Michael. (1952). *Primary love and psycho-analytic technique*. London: Hogarth.
- . (1958). The three areas of the mind. Theoretical considerations. *International Journal of Psychoanalysis*, 9, 328–340.
- . (1959). *Thrills and regressions*. London: Hogarth.
- . (1964). *The doctor, his patient, and the illness* (2nd ed.). London: Pitman Medical Publishing. (1st edition published 1957)
- . (1968). *The basic fault: therapeutic aspects of regression*. London: Tavistock.

## **BASIC NEUROSIS, THE—ORAL REGRESSION AND PSYCHIC MASOCHISM**

“A most original thinker and prolific writer,” in this book Bergler compiled the results from his 130 published papers and 6 books based on 22 years of clinical experience. Renowned for his research on oral neurosis, he discovered there is but one “basic neurosis”—repressed masochistic attachment to the fantasied ear-

liest “bad mother”; later neuroses “reformulating” oral masochistic material represent “rescue stations”; psychic masochism (PM), the unconscious pursuit of “pleasure in displeasure,” forms the core of oral regression. Thus, neurotic equals psychic masochist. Neurotics cling to and repeat misery, in itself indicating PM. PM unconsciously “sugarcoats” and “neutralizes” pain; but consciously pain remains, felt in symptoms and personality distortions.

To Freud’s “genetic picture” of PM (megalomania unavoidably offended by perceived frustration of libido; fury; helpless aggression rebounding; libidization of guilt), Bergler worked out and added the “clinical picture.” He named it the “mechanism of orality”:

1. Unconscious provocation or misuse of “refusal”; casting others as “bad, refusing mother.”
2. Retaliation for the alleged “injustice” by pseudoaggressively fighting in righteous indignation.
3. Self-pity then unconsciously enjoyed.

With this base, every clinical entity incorporates a unique “specific additional factor”; 27 clinical pictures with case illustrations substantiate this. Psychic masochists unconsciously want refusal, rejection, humiliation, defeat. The genuine “wish to get” of infancy is now a defense. They believe they want normal pleasure, but a person “who unconsciously runs after disappointment cannot be consciously happy.” All neurotic aggression is “pseudoaggression,” promoting self-damage. Neurotics shift the blame outside, mostly to parents; this Bergler named the “basic fallacy” which must be shown to be a fallacy.

Applying these ideas, Bergler advocated new clinical solutions, such as talking at length to patients to counteract their projection of “bad refusing mother” (facilitating analysis), and more active analyzing, to unearth and interpret all repressed masochistic data and repetitions. He added theory regarding transference/love, creativity, working through, masturbation, money-neurosis, fashion, gambling, homosexuality, and humor. Bergler deduced mechanisms of cynicism, hypocrisy, criminosis; described and/or named alysis, middle-age revolt, confusionism, 22 visual neuroses, writer’s block, psychogenic aspermia, counterfeit-sex, and “pseudo-moral connotation of neurotic symptoms” (ironization of teachings to prop up each symptom). He identified the superego (SE) (“torture

for torture’s sake”) as the “real master of the personality,” requiring constant appeasement. Daimonion (the punitive part of SE) uses the ego ideal to torture the ego; also that punishment is masochized. Psychic masochism is disguised from the superego by two defensive alibis (in the five-layer structure of neurotic symptoms and traits). In the normal, the fifth layer is antimasochistic; in neurosis, the final layer “smuggles in” masochism in self-damaging symptoms. Hence, neurotics cannot be helped unless their PM is analyzed. Eighteen further books detail his later discoveries. Growing numbers of adherents are confirming the accuracy and clinical value of his work.

MELVYN I. ISCOVE

See also: Bergler, Edmund; Masochism; Neuroses.

### Source Citation

Bergler Edmund. (1949). *The basic neurosis—oral regression and psychic masochism*. New York: Grune and Stratton.

### Bibliography

- Bergler, Edmund. (1989). *The superego*. Madison, CT: International Universities Press. (Original work published 1952)
- . (1982). *Counterfeit-sex*. New York: Grune and Stratton. (Original work published 1958)
- . (1992). *Principles of self-damage*. Madison, CT: International Universities Press. (Original work published 1959)
- . (1993). *Curable and incurable neurotics*. Madison, CT: International Universities Press. (Original work published 1961)
- . (1969). *Selected papers of Edmund Bergler, M.D., 1933–1961*. New York: Grune and Stratton.
- Jaffe, Daniel. (1986). Review of the revolt of the middle-aged man. Money and emotional conflicts, and the psychology of gambling. *International Journal of Psycho-Analysis*, 67, 507–509.

## BASIC PROBLEMS OF ETHNOPSYCHIATRY

Dedicated to Marcel Mauss and with a preface by Roger Bastide, the essays in *Basic Problems of Ethnopsychiatry* were published between 1940 and 1967 in American anthropology, psychiatry, criminology, and

psychoanalysis reviews (*American Anthropologist*, *Bulletin of the Menninger Clinic*, *Journal of Criminal Psychopathology*). The author provided additional commentary for some of the texts at the time of their publication.

In spite of the diversity of the topics, the collection provides insight into the sources of Devereux's thought, his experiences as an ethnologist among the Mohave Indians of California and the Sedangs Moi of Vietnam, as well as his research on sociology and mythology. These included the definition of ethnopsychiatry as a reference frame for clinical work and research in psychiatry; the qualification of the concepts of ethnic personality and its disorders (sacred, typical, idiosyncratic); the status of culture in psychological disturbances such as psychosis, neurosis, somatic disturbance, deviance; and the additional possibilities of functional and cultural disturbances. For example, in "A Sociological Theory of Schizophrenia" Devereux analyzes the effects of modern societies on the disorientation and dysphoria of its members.

The author draws the attention of psychiatrists, psychoanalysts, and anthropologists to the reciprocity of oedipal conflicts between adult and child and to the presence in some societies of models of conventional misconduct that can be used directly in private and "negativist" fantasies. Devereux also reiterates the importance of diagnosing any antisocial "warning symptoms" in disturbed individuals, even those who are least obvious, not as a function of existing norms but as a function of their singularity and distance from culture and the materials it offered them.

For Georges Devereux culture was an interior experience and a way of "living experience." Through his methodology, based on the complementarity of psychological and sociological data, and his theoretical opposition to any form of cultural relativism in the explanation of mental disorders—he believed in the mental unity of human beings—the role of psychoanalysis in ethnological research has been established. Through its coherence and scholarship, Devereux's work provides unique support for the use of ethnopsychiatry in the investigation of culture.

SIMONE VALANTIN

*See also:* Anthropology and psychoanalysis; Devereux, Georges; Ethnopsychanalysis; Individual; Transcultural.

### Source Citation

Devereux, Georges. (1980). *Basic problems of ethnopsychiatry* (Basia Miller Gulati and George Devereux, Trans.). Chicago: University of Chicago Press.

---

## BAUDOIN, CHARLES (1893–1963)

Charles Baudouin was born July 26, 1893, in Nancy, France, and died on August 25, 1963, in Geneva, Switzerland

During his career, he was a Swiss psychoanalyst and Privatdocent at the University of Geneva (1920), founder of the International Institute of Psychagogy and Psychotherapy (1924), director of the review *Action et Pensée* (Action and Thought) (1931), Chevalier of the Legion of Honor in Paris (1950), and associate professor at the University of Geneva (1962).

His father had a career in the French military as a non-commissioned officer in the public health service, and his mother came from a family of middle-class shopkeepers in the German-speaking area of Lorraine. Baudouin studied philosophy in Nancy, where he received his degree in 1912. He was a professor of philosophy at the school of Neufchâteau in the Vosges. In 1915 he traveled to Geneva, attracted by the success of the Jean-Jacques Rousseau Institute, where he taught. He wrote his doctoral dissertation, entitled *Suggestion et Autosuggestion*, at the University of Geneva in 1920.

Baudouin underwent three different analyses: One in 1917 with Dr. Carl Picht, a Jungian analyst, another, a training analysis, with Charles Odier, between 1925 and 1926, and a third with another Jungian, Tina Keller. Fluent in both French and German, Baudouin read the work of Freud and the first psychoanalysts early in his career. He met Freud in Vienna in 1926. In 1929 Baudouin applied for membership in the Société Psychanalytique de Paris, but his request was rejected because of pressure from Henri Flournoy, who insisted that he would join the organization only upon condition that Baudouin not be admitted.

Baudouin spent much of his career trying to reconcile the work of Jung, Freud, and Adler. His earliest work was devoted to suggestion and hypnosis. He later

developed an interest in literature and the relation between psychoanalysis and education. Baudouin's literary output throughout his career was considerable. He wrote a *Carnet de route* in sixteen volumes (1910–1939), only some of which were published. These notebooks provide valuable commentary concerning the psychoanalytic atmosphere prevalent at the time. *Carnet VI* (October 1918–December 1921) is entitled, "When the Child Appears." His first book was *Suggestion and Autosuggestion* (1920). His most important publications include *Études de psychanalyse* (1922), *Qu'est ce que la suggestion?* (1924), *Le Symbole chez Verhaeren* (1924), *Psychanalyse de l'art* (1929), *La Mobilisation de l'énergie* (1931), *L'Âme enfantine et la psychanalyse* (1931), *La Psychanalyse* (1939), *Psychanalyse et Victor Hugo* (1943), *L'Âme et l'Action* (1944), *De l'instinct à l'Esprit* (1950), *Y a-t-il une science de l'âme?* (1957), *Psychanalyse du symbole religieux* (1957). He also wrote a novel, *Christophe le passeur* (1964).

Baudouin's work merits greater attention from modern historians and psychoanalysts. His concerns and fields of interest are often directly relevant to contemporary psychoanalysis. He is a precursor in a number of fields (art, education, suggestion, and hypnosis). Baudouin did not adhere to orthodox Freudianism and turned to Jung and Adler for the theoretical elements that he felt were relevant for clinical work.

MIREILLE CIFALI

*See also:* Autosuggestion; Suggestion; Switzerland (French-speaking).

### **Bibliography**

- Baudouin, Charles. (1920). *Suggestion et autosuggestion*. Neuchâtel-Paris: Delachaux and Niestlé.
- . (1924). *Qu'est-ce que la suggestion? Introduction à la psychologie de la suggestion et de l'autosuggestion*. Neuchâtel-Paris: Delachaux and Niestlé.
- . (1931). *L'Âme enfantine et la psychanalyse*. Neuchâtel-Paris: Delachaux and Niestlé.
- . (1957). *Psychanalyse du symbole religieux*. Paris: Fayard.
- Cifali, Mireille. (1990). De quelques remous helvétiques autour de l'analyse profane. *Revue internationale de la histoire de la psychanalyse*, 3, 145–157.

Roudinesco, Élisabeth. (1986). *La Bataille de cent ans. Histoire de la psychanalyse en France* (Vol. 2). Paris: Le Seuil.

### **BAUER, IDA (1882–1945)**

Ida Bauer, alias Dora, is the subject of Freud's famous case history on an adolescent (Freud, 1905).

Her father, Philip Bauer, who became a rich textile industrialist, was born in 1853 in Pollerskirchen. Her mother, Katherina or Käthe (née Gerber), was born in 1862 in Königinhof, a village that, like her husband's birthplace, was located in the eastern part of Bohemia. Shortly after marriage, the Bauers had their only two children, both born in Vienna: Otto, born on September 5, 1881; and Dora, November 1, 1882. Contrary to his sister, whose reputation stemmed solely from her patienthood, Otto achieved eminence as the parliamentary leader and foreign minister of the First Austrian Republic, as its chief Marxist theorist, and as secretary to the Austrian Social Democratic Worker's Party.

After contracting tuberculosis, the wealthy Philip moved with his family in 1888 from Vienna to B—, Freud's designation for Merano, a Tyrolean resort town that is presently in Italy and situated four hundred kilometers to the southwest of Vienna. In Merano the Bauers befriended another resident couple, designated by Freud as Herr and Frau K, the letter pronounced in German the same way as the last syllable of their real married name, Zellenka. Hans Zellenka and his wife Peppina (née Heumann) had two young children, Otto and the congenitally ill Klara, both born in 1891. Although afflicted herself with bouts of *tussis nervosa* and aphonia, Dora would care for both her sick father and the Zellenka children.

In 1894 Philip became even more sick. Nursed by Peppina, Philip then started a long liaison with her. Dora's conflicts were aggravated by that liaison and also by two traumata that she suffered at the hands of Hans. Although she consulted Freud once in 1898, Dora did not go into treatment with him until the earlier part of October 1900; she abruptly terminated treatment nearly three months later, on the last day of the year. In 1903 she married Ernst Adler, who, not succeeding as a musician, went to work for her father. Summoned by Dora's physician, Felix Deutch visited the bedridden patient in 1923; reportedly she suffered from almost paranoid behavior and found all men

detestable. (Dora's one son, Kurt Herbert, won fame as the director of the San Francisco Opera Company.)

In a fateful twist of history, Dora and Peppina later became friends; both were partners as bridge masters during the 1930s when the card game was the craze in Vienna. Because of her brother Otto's Marxist affiliation, the Nazis sought Dora in the late 1930s, and she hid in Peppina's home. Dora emigrated to Paris, and then to New York where she died.

PATRICK MAHONY

See also: "Fragment of an Analysis of a Case of Hysteria" (Dora/Ida Bauer).

### **Bibliography**

- Decker, Hannah. (1991). *Freud, Dora, and Vienna 1900*. New York: The Free Press.
- Freud, Sigmund. (1905e [1901]). Fragment of an analysis of a case of hysteria. *SE*, 7: 1–122.
- Loewenberg, Peter. (1985). *Decoding the past: The psychohistorical approach*. New Brunswick, NJ: Transaction.
- Mahony, Patrick. (1996). *Freud's Dora: A historical, textual, and psychoanalytic study*. New Haven, CT: Yale University Press.
- Rogow, Arnold. (1978). A further note to Freud's "Fragment of an analysis of a case of hysteria". *Journal of the American Psychoanalytic Association*, 26, 311–330.

---

**BEDWETTING.** See **Enuresis**

---

### **BEIRNAERT, LOUIS (1906–1985)**

Louis Beirnaert, a French Jesuit and psychoanalyst, was born on April 2, 1906, in Ascq and died on April 30, 1985, in Paris. Beirnaert became a Jesuit in 1923. An almoner for law students during the Second World War, he took part in a resistance network and went underground. After the war he became a professor of dogmatic theology (1947–1951). He began his analysis with Daniel Lagache and became an analyst himself.

In 1953 he founded, together with Father Charles Durand (Geneva), Doctor Charles Nodet (Société psychanalytique de Paris [Paris Psychoanalytic

Society]), and Father Bruno de Jésus–Marie (Carmelite studies), the Association Internationale d'Études Médico-Psychologiques et Religieuses (International Association of Medico-Psychological and Religious Studies) to promote the understanding of psychoanalysis within the Catholic church. During the early sixties, he created in France, together with Andrée Lehmann, Abby Marc Oraison, and Father Albert Plé (Dominican, director of the Supplément), the Association Médico-Psychologique d'Aide aux Religieux [Medico-Psychological Association for Assistance to the Clergy], which provided members of the clergy with access to psychoanalysis and a better understanding of its possibilities.

He was a member of the Société Française de Psychanalyse (French Psychoanalytic Society), the École Freudienne de Paris (Freudian School of Paris), and was close to Jacques Lacan. Throughout this period he was also the editor of the Jesuit publication *Études*, for issues of morality, psychology, and psychoanalysis. Through his writing and numerous personal associations, Beirnaert exercised considerable influence on improving relations between psychoanalysis and the Catholic church. He wrote a number of articles on psychoanalysis, ethics, and the interrelation of psychoanalysis and Christianity.

JACQUES SÉDAT

See also: France; Religion and psychoanalysis.

### **Bibliography**

- Beirnaert, Louis. (1966). *Expérience chrétienne et psychologie*. Paris: L'Épi.
- . (1986). *Aux frontières de l'acte analytique*. Paris: Le Seuil.

---

### **BELGIUM**

There were signs of interest in Belgium for Freud and Breuer's research on hysteria as early as 1894. References can be found in Dallemagne's *Dégénérés et déséquilibrés* (Degeneracy and Mental Imbalance), but this appears to be an isolated case (Berdondini, N., 1987). During the twenties, a few attempts were made to introduce young psychiatrists to psychoanalytic concepts, but there was vehement opposition from the old guard. In literature a special issue of *Disque vert* appeared in 1924, entirely devoted to Freud. The

Belgian authors included Georges Dwelshauwers, André Ombredane, and Henri Michaux. In his later writing, Franz Hellens, director of the publication, was also sympathetic to the work of Carl Gustav Jung. At the University of Louvain, following the initiative of the future cardinal Mercier, several professors took an interest in Freudian theory and established individual critical positions because of the emphasis placed on sexuality. The Jesuit J. Maréchal was also influential in promoting early acceptance of psychoanalysis.

In the midst of these still limited signs of interest, there emerged the figure of an educator from Gand, Julien Varendonck (1879–1924), who had the good fortune to meet Freud and become one of his students. He underwent a training analysis with Theodor Reik and spent 1923 in Vienna to continue his education. Upon his return to Gand, he opened his own office and was made a member of the Dutch Society of Psychoanalysis shortly before his premature death on June 11, 1924. In 1921 he published an important monograph entitled *La psychologie des rêves éveillés* (The Psychology of Daydreams), with a preface by Freud. Anna Freud translated the first part of the book. Unfortunately, because he was unable to find any students or an analysand with whom he could continue his research, his initiative remained stillborn.

The foundations of psychoanalytic practice were established by two Belgian pioneers, Maurice Dugautiez (1893–1960) and Fernand Lechat (1895–1959). The beginnings of psychoanalysis in Belgium reflect Freud's own solitary struggle during the first decade of the twentieth century. A closed and poorly informed medical establishment—the organic approach dominated psychiatry at the time—and a public opinion that remained hostile because of sectarian prejudices, explain why Freud's work had to wait for the arrival of two idealists who remained far outside the conventional sphere of training before psychoanalysis could take hold in the country. Both men were self-taught, curious and passionate individuals, who first met in 1933. Their encounter was the prelude to years of fruitful collaboration that enabled a psychoanalytic organization to gain a foothold in Belgium.

In spite of the dramatic context in which it occurred, another fortuitous event took place in 1933 or thereabouts. A Viennese Jew, Dr. Ernst Hoffman, a disciple of Freud and a brilliant student of Sándor Ferenczi, settled in Anvers to escape Nazi persecution. Dugautiez and Lechat, together with Mrs. Lechat, who

was primarily interested in working with children, took advantage of Hoffman's providential appearance and began a training analysis with him. Unfortunately, Hoffman was arrested in 1942 and sent to a concentration camp. He never returned, and the nascent Belgian psychoanalytic movement suddenly lost its leader.

Beginning in 1936 Dugautiez and Lechat began undergoing supervised analyses under the supervision of Dr. Leuba and Marie Bonaparte. They were authorized to practice on their own in 1939; Mrs. Lechat began working with children at this time. After the war ended, both of them applied for membership in the Paris Psychoanalytic Society and were authorized, in 1946, to conduct training analyses and supervise their own students' first analyses.

On December 24, 1946, they founded the Association des Psychanalystes de Belgique (Association of Belgian Psychoanalysts) with Dr. Leuba as honorary president. They were sponsored by the Psychoanalytic Society of Paris. Doctor Ernest Jones, president of the International Psychoanalytic Association (IPA), had encouraged this initiative. In 1947 the association, with the sponsorship of Marie Bonaparte, was accepted for membership in the IPA. The standing of the young organization was made more secure in 1948 with the organization, in Brussels, of the eleventh Conférence des Psychanalystes de Langue Française [(Conference of French-speaking Psychoanalysts)]. During the twelfth conference, in 1954, Fernand Lechat presented a report on "The Principle of Security." There were three further meetings in Brussels: in 1958, in 1972 (when a report was given by Danièle Flagey, entitled "Intellectual Inhibition"), and in Liege, in 1986, with a report by Andrée Bauduin, "On the Preconscious."

In 1953, Dr. Thérèse Jacobs Van Merlen, who had returned from her training in Paris with Sacha Nacht, Serge Lebovici, and René Diatkine, joined Dugautiez and Lechat. A stream of new members joined the association: Flagey, Bourdon, Vannypelseer, Drappier, Luminet, Pierloot, Labbé, Darmstaedter, Duyckaerts, and later, Watillon and Godfrind. The association has continued to grow since then. In 1960 the name was changed to the Société Belge de Psychanalyse (Belgian Psychoanalytic Society), also known as the Belgische Vereniging voor Psychoanalyse.

The society continued to grow, with the addition of a teaching committee, an enlarged administrative



office, and an ethics committee. In addition to bimonthly meetings and working groups, the entire society met every two years for a colloquium. The *Revue belge de psychanalyse*, with Haber as its first director, was founded in 1982. The review made the society's ideas accessible to a much broader public. There was also a members' *Bulletin*, created in 1977.

Some twenty years after the creation of the current Belgian Psychoanalytic Society, various activities were established by psychoanalysts who had returned home from abroad and who were, for the most part, associated with the University of Louvain. These individuals either could not, or would not, become a part of the existing society. Most of them had met in Paris between 1955–1960, where they followed the activities of the French Psychoanalytic Society, which was then run by Daniel Lagache and Jacques Lacan, with the assistance of Juliette Boutonier, Françoise Dolto, and Georges Favez. Following a break in 1953 with the Paris Psychoanalytic Society, in 1964 the French Psychoanalytic Society experienced new upheavals with the departure of Lacan and the creation of the École Freudienne. Although some activities of the new Belgian group began in 1964, the official foundation of the École Belge de Psychanalyse (Belgische School voor Psychoanalyse) did not take place until 1969, under the impetus of Professors Jacques Schotte and Antoine Vergote.

Lacan's influence was decisive within the school, to the extent that its establishment can be considered an implicit extension of the situation in France. This allegiance to Lacanian positions, at least on the part of some, became problematic when the dissolution of the École Freudienne by Lacan led to divisions that subsequently gave rise to numerous offshoots, including Questionnement Psychanalytique (Psychoanalytic Questioning) and the Association Freudienne de Belgique (The Freudian Association of Belgium). These various groups are the result of the differences encountered concerning the importance of Lacanian ideas, in terms of setting and training, and more generally in terms of the theoretical corpus. Unlike the Belgian Psychoanalytic Society, these associations were not part of the IPA, some even took pride in their separatist stance. In 1984 the École Belge de Psychanalyse began publishing a bilingual review, *Psychoanalyse*.

There were also Jungian psychoanalysts working in Belgium. The Société Belge de Psychologie Analytique

(Belgian Society of Analytic Psychology), or SBPA, was founded in 1975. The majority of its members had been analyzed by Gilberte Aigrisse (1911–1995), who was trained in Geneva by Charles Baudouin. In 1994 some members of the SBPA left the organization to found a new group known as the École Belge de Psychanalyse Jungienne (Belgian School of Jungian Psychoanalysis), or EBPJ.

ANDRÉ ALSTEENS

### **Bibliography**

- Baudouin, Andrée. (1987). Du préconscient. *Revue française de psychanalyse*, 51, 449–538.
- Berdondini, Nadine. (1987). *L'introduction de la psychanalyse en Belgique: 1900–1947*. Louvain-la-Neuve, reprinted 1995.
- Flagey, Danièle. (1973). L'inhibition intellectuelle. *Revue française de psychanalyse*, 36, 717–798.
- Lechat, Fernand. (1955). Du principe de sécurité. (rapport). *Revue française de psychanalyse*, 19 (1–2), 11–101.

## **BELIEF**

Belief is the condition of holding a thing to be true or probable, giving credit to a person or an idea, giving credence to or having faith in a story. In this last sense belief is related to theology and economy. The believer is situated in a religious system in which he adopts a certain number of convictions, accepts a series of dogmas and makes this credo a guideline for living. Belief may have to do with clinging to a truth or belonging to a church or a party. The believer is also indebted to the person or persons, parents or teachers or others, who provide the material for belief, and possess a capital of confidence and a stock of responses, encouraging or obliging the believer to borrow from them models of reasoning and types of solutions.

The theme of belief is directly addressed by Sigmund Freud in a note accompanying a letter to Wilhelm Fliess dated May 31, 1897. There, belief is described as a phenomenon belonging entirely to the ego system (consciousness), without any unconscious equivalent. The topic had already been addressed indirectly in chapter 12 of the *Studies on Hysteria* (1895d), belief there being associated with superstition (p. 250).

It may seem paradoxical to speak of belief in the context of psychoanalysis. Freud described himself as nonbeliever and made no secret of his atheism. But precisely this external position with respect to unproven truth made him see belief as an anomaly that needed to be explained. Influenced by the positivism and scientism of his time, he considered belief to be a relic of childhood. He thus placed himself within the tradition of Auguste Comte, who believed that the individual and humanity as a whole both went through a childish stage with theological and military characteristics. He considered that the church and the army were the two social institutions responsible for perpetuating this stage. The reference to childhood here is bound up with the role of the father: God is the father of believers, who are all brothers; likewise the commander-in-chief is the father of soldiers, who are all comrades. The belief in salvation or victory is thus vital for maintaining the sense of family.

For Freud the concept of belief is inseparable from childhood theories of sexuality that continue to be held by the individual or by society. The little boy believes that women (and therefore his mother) have a penis. Society believes that the child has no sexuality. Belief is always associated with a disavowal of reality. The renunciation of belief is then an educational task and a psychological struggle, both liable to encounter much resistance. Psychoanalytic treatment cannot itself dispense with belief, for the transference, which reactivates infantile processes, demands that the patient lend credence to the analyst's words even though these do not belong to the realm of demonstrable truth. The better to remove the need for belief, therefore, psychoanalysis is obliged temporarily to replace one belief by another.

Differing attitudes regarding belief broadly coincide with the major splits in psychoanalysis and the schisms that have marked its history. In the early days, there was a "left" psychoanalysis, centered around Alfred Adler and the Social Democrats, which believed in popular revolution and the possibility, within a new political system, of eliminating alienation in both the social and the psychiatric senses of the word. A "right" tendency, meanwhile, epitomized by Carl Gustav Jung, believed in a metamorphosis of the soul and an internal unification of man that could heal all dislocations of being and all fissures in the ego. Freud was suspicious of all such beliefs, and his clinical experience tended to make him pessimistic about the possibility

of separating belief from illusion. He saw the need to believe as a powerful means of mobilizing the instincts and manipulating the unconscious: so loath were man and society to consent to what Max Weber called the disenchantment of the world that they continually felt the need to believe in the unbelievable, to hope against all hope in some distant paradise or in glorious tomorrows.

Skepticism did not in Freud's view mean a refusal of values. Values were indeed necessary for the progress of culture and its corollary, the renunciation of the immediate satisfaction of instinctual impulses. The values of civilization called nonetheless for a truly critical scrutiny that held fast to one most important principle: to fear no truth no matter how painful it might be.

ODON VALLET

*See also:* *Future of an Illusion*, *The*; Illusion; Occultism; Omnipotence of thought; Paranoia; Psychoses, chronic and delusional; Science and psychoanalysis; Superego.

### **Bibliography**

- Dolto, Françoise. (1996). *Les évangiles et la foi au risque de la psychanalyse*. Paris: Gallimard.
- Freud, Sigmund. (1927c). The future of an illusion. *SE*, 21: 5–56.
- (1930a [1929]). Civilization and its discontents. *SE*, 21: 64–145.
- Freud, Sigmund, and Breuer, Josef. (1895d). Studies on hysteria. *SE*, 2.

### **BENEDEK, THERESE (1892–1977)**

Therese Benedek, a Hungarian psychoanalyst, was born in Budapest on November 8, 1892, and died in Chicago on October 27, 1977. She received her medical diploma from the University of Budapest in 1915. She underwent five months of analysis with Sándor Ferenczi, then in 1918 settled, along with her husband Tibor, in Leipzig. From 1920–1923 she completed her analytic training at the newly established Berlin Institute, where she attended seminars and conducted analyses under the supervision of Karl Abraham and Max Eitingon. A partisan of "developmental psychoanalysis," Benedek followed Ferenczi's recommendation for flexibility during therapy.

In 1933 she emigrated with her husband and their two children to the United States. In 1936 Franz Alexander offered her an administrative position at the Chicago Institute of Psychoanalysis, where he was the director. Here she participated actively in research on psychosomatic medicine for effective coordination of somatic and psychotherapeutic therapies, and published an article on the functions of the sexual apparatus and their disturbances. This study investigated the interaction between organic (hormonal) factors and the psychosexual economy in sexual disturbances by showing their close interdependence.

In 1949 she was one of the first psychoanalysts to speak of the mother-child dyad in terms of emotional symbiosis, insisting on a transgenerational reading of interaction during infancy. Ten years later, in *Parenthood as a Developmental Phase*, she referred to the interpersonal process that formed the basis of the mother-child interaction as a “transactional spiral,” which took place through the reciprocal identifications and introjections between mother and child.

DELPHINE SCHILTON

See also: Germany; Hungarian School; Parenthood.

### **Bibliography**

- Benedek, Therese. (1949). The psychosomatic implications of the primary unit: mother-child. *American Journal of Orthopsychiatry*, 19, 642–654.
- . (1956). Psychobiological aspects of mothering. *American Journal of Orthopsychiatry*, 26, 272.
- . (1959). Parenthood as a developmental phase. *Journal of the American Psychoanalytic Association*, 7, 389–417.
- . (1973). *Psychoanalytic Investigations: Selected Papers*. New York: Quadrangle Books.

## **BENIGN/MALIGNANT REGRESSION**

The notion of benign versus malignant regression comes from Michael Balint’s book *Thrills and Regressions* (1959); he distinguished two types of regression that can appear during analysis. The benign form is minor, temporary, and reversible; the other, malignant form is major, serious, lasting, or even irreversible. The former brings with it beneficial, therapeutic effects; the latter is pathogenic and can potentially

result in insurmountable problems for the patient and the analysis.

Regression, discovered very early on by Sigmund Freud in its topographical, temporal, and formal aspects as a defense mechanism and therapeutic support, suddenly appeared as a threat to the patient and to treatment. Generations of analysts thus came to dread it. Balint took up this issue at the point at which Freud and then Sándor Ferenczi had left off, and between 1932 and 1960 he created this notion, which aimed to change analysts’ attitude toward this phenomenon.

Balint no doubt used the terms *benign* and *malignant* with reference to the work of Otto Warburg, his former boss at the Berlin Charity Hospital, on tumors, for which Warburg won the Nobel Prize in 1931. The analogy is found in surgical techniques. This clinical distinction goes beyond the theoretical positions and techniques of Freud and Ferenczi. Freud recommended that regression be overlooked in analytic technique and saw it as a therapeutic support, but he advised analysts to maintain a degree of distance. Ferenczi used it and even provoked it (trance states) for therapeutic ends, and, during the 1930s, carried away by theoretical fervor, he conducted his “great experiment.” He devoted himself completely to his patients and responded to their impassioned demands with small gratifications; he also gave the patients extra sessions on demand, day or night, including during vacations.

The experiment elicited Freud’s “massive condemnation” (Freud, Letter to Ferenczi, December 13, 1931), which Balint called “unfair and not very productive” (1968). Balint reassessed Ferenczi’s approach during his continuation, after 1933, of Ferenczi’s unfinished analyses; this enabled him to understand his predecessor’s errors. The question arose as to whether he should return to the former techniques with these patients or rather, as he had begun to, derive a new evaluation of their object relations and make a prognosis of the transference (massive or non-massive) in order to adapt the treatment accordingly.

He then elaborated a differential diagnostic between two syndromes he called “Cluster A and Cluster B” (1968) with their respective constant characteristics: mutual trust or its absence, demands that were either moderate or insatiable, the inclusion of addictive states or none, and so on. To avoid “the appearance of a

malignant form of regression,” he advocated the development of adapted analytic techniques: The “discreet” (not omnipotent or needlessly intrusive) analyst must create the secure, permissive atmosphere that the patient needs, as well as the time needed for regression and what he called a “new beginning.” This notion, linked to his theory of the “basic fault,” is unquestionably the one that in Balint’s corpus has had the greatest influence among analysts.

MICHELLE MOREAU RICAUD

See also: Basic fault.

### **Bibliography**

Balint, Michael. (1959). *Thrills and Regressions*. New York: International Universities Press.

———. (1968). *The basic fault: Therapeutic aspects of regression*. London: Tavistock Publications.

Freud, Sigmund, and Ferenczi, Sándor. (1992–2000). *The correspondence of Sigmund Freud and Sándor Ferenczi* (Eva Brabant, Ed., and Peter T. Hoffer, Trans.). Belknap Press of Harvard University Press.

---

## **BERGE, ANDRÉ (1902–1995)**

A French physician and psychoanalyst, André Berge was born on May 24, 1902, in Paris and died on October 27, 1995, in Neuilly-sur-Seine.

Although Berge did not know him, President Félix Faure was his maternal grandfather and there is little doubt that this played a role in Berge’s choices later in life. He grew up with two brothers in a free-thinking, upper-middle class, Catholic family with extensive social connections. His mother, Antoinette Félix-Faure, was a childhood friend of Marcel Proust. His father, René Berge, was a mining engineer, his uncle a perpetual secretary of the French Academy, his aunt a founding member of the “Ligue Fraternelle des Enfants” and a student of Maria Montessori. His secondary education took place at the Lycée Janson-de-Sailly, where he primarily studied literature. He published novels before founding, with his brother François, *Les Cahiers du mois*, in 1924, the year of his marriage to Geneviève Fourcade, with whom he had six children. A book of memoirs, *Réminiscences* (1977), described the events of the first half of his life.

In 1930 Berge participated in the foundation of the *École des Parents*, where he remained vice-president practically for the remainder of his life. He subsequently became interested in psychoanalysis. In 1939 he decided to undergo therapy with René Laforgue and, after joining the “Club des Piqués” consisting of Laforgue’s analysts, became close with Juliette Favez-Boutonier, Françoise Marette (later Françoise Dolto), and Georges Mauco. He decided to study medicine, which he continued during the Occupation, and focused on child psychiatry with an emphasis on psychoanalysis with Professor Georges Heuyer. Berge earned an M.D. in 1946, he became an associate member of the *Société Psychanalytique de Paris* (Paris Psychoanalytic Society) that same year. He was named a full member in 1948.

In 1946 Berge joined the staff of the newly created Centre Psychopédagogique Claude-Bernard, founded by Georges Mauco. He became head of the medical section the following year, remaining director for twenty-six years, until 1973. In 1965 he founded the Association pour la Réadaptation des Infirmes Mentaux (APRIM) [Association for the Rehabilitation of the Mentally Disabled], was president of the Fédération Internationale pour l’Éducation des Parents et des Éducateurs [International Federation for the Education of Parents and Educators] (1973–1979), president of the Montessori Association of France, and a teacher at the Institut de Psychologie from 1961 to 1971. His many activities in international and national organizations, and his many articles assured him a place among the leading educators in the field of child psychoanalysis.

It was in this capacity that, between 1950 and 1952, he became involved in the trial of Margaret Clark-Williams—a psychologist who had been accused of practicing medicine without a license—defending her right to practice psychoanalysis. His subsequent participation in the French psychoanalytic movement was somewhat unique. Even after the 1953 split, for several years he remained a member of the two rival societies, the *Société psychanalytique de Paris* (Paris Psychoanalytic Society) and the *Société française de Psychanalyse* (French Society for Psychoanalysis), founded by Daniel Lagache, Françoise Dolto, and Jacques Lacan, his former analyst. Berge was at the time an editor of the review *Psyché*, founded by Maryse Choisy in 1947, several of whose contributors were also members of the French Society for Psychoanalysis.

While efforts were being undertaken to integrate the French Society for Psychoanalysis within the International Psychoanalytic Association, he became a victim of an error on the part of the negotiators and was named, along with Jacques Lacan and Françoise Dolto, as one of those whom the international authorities wanted to exclude from the list of educators. After the mistake was rectified, he joined the non-Lacanian and created the Association Psychanalytique de France (Psychoanalytic Association of France). Berge was president from 1969–1970 but, faithful to his unique status of “dual membership,” was, in 1965, also elected an associate member of the Paris Psychoanalytic Society, which he had been forced to quit shortly before.

Aside from *Les Psychothérapies* (1968), Berge is the author of a number of articles, talks, and books on psychopedagogy, of which he was one of the leading promoters in France. These were anthologized in *André Berge: écrivain, psychanalyste, éducateur* (1995). In 1936 his book *L'Éducation familiale* was recognized by the Académie des Sciences Morales et Politiques. Other books followed, including *Le Métier des parents* (1956), *L'Enfant au caractère difficile* (1970), and *La Sexualité d'aujourd'hui* (1970). Berge outlined the course of his life in a series of interviews with Michel Mathieu in 1988; in spite of blindness, he remained lucid and active until his death.

Didier Anzieu, in his preface to *André Berge: écrivain, psychanalyste, éducateur*, referred to his work as “protean” and praised the “flexible, open-minded, and rigorous approach that varied with the individual and the context of the exchange. This provided him with direct, rapid insights and the ability to transcribe them with simplicity in clear and convincing language, with less dependence on theory.”

ALAIN DE MIJOLLA

See also: Centre psychopédagogique Claude-Bernard; Clark-Williams, Margaret; France; Société française de psychanalyse.

### Bibliography

- Berge, André. (1936). *L'éducation familiale*. Paris: Montaigne.
- . (1968). *Les psychothérapies*. Paris: P.U.F.
- . (1970). *L'enfant au caractère difficile*. Paris: Hachette.

———. (1988). *De l'écriture à la psychanalyse, entretiens avec M. Mathieu*. Paris: Clancier-Guénéaud.

———. (1995). *André Berge: Écrivain, psychanalyste, éducateur*. Paris: Desclée de Brouwer.

---

## BERGGASSE 19, WIEN IX

In September 1891 Sigmund Freud, with his wife Martha and his children Mathilde, Martin, and Oliver, moved into a newly constructed building, Berggasse 19, in Vienna's ninth district. Built according to plans by Alexander Stierlin, the building was perfectly suited to its surroundings, consistent with the architecture of the Gründerzeit (founders) style, which changed the face of Berlin, Vienna, and Paris. There were fourteen apartments in the building, all of them sumptuous.

Freud's family occupied the first floor, and it was there that Ernst, Sophie, and Anna were born. In 1896, because of a lack of space, Freud rented an office on the floor below since the apartment opposite his was occupied by his sister Rosa Graf and her children. It wasn't until 1908, when Rosa and her family moved out, that Freud moved into the apartment where he saw patients and received his friends, and which was later catalogued by the photographer Edmund Engelman. He left the apartment in 1938, bringing with him his furniture, his collection of antique objects, and his personal belongings.

After 1908, Freud's family occupied the entire first floor. During the 1930s, Dorothy Burlingham, born Dorothy Tiffany, moved into the second floor while her children were undergoing analysis with Anna Freud. She became friends with Anna and later her close collaborator.

In 1902 a small group, known as the Wednesday Society, began meeting in the apartment at Berggasse 19; it was the first psychoanalytic discussion group. It was there as well that Freud met with his colleagues—many of whom he considered friends—including Sándor Ferenczi, Max Eitingon, and Ernest Jones, along with writers and intellectuals. It was in his office there that Freud wrote the majority of his work.

Since the turn of the century, Freud had surrounded himself with his collection of antique objects, continuously enriched, initially by the purchases he himself made during his trips to Italy and then by those of his

friends and colleagues, especially Emanuel Loewy, a professor of archeology. At the end of his life, Freud's collection contained some two thousand, five hundred objects. He got great enjoyment out of the collection, especially when his cancer prevented him from traveling. When he and his family were forced to flee the country, the apartment was rented and all traces of his presence in it disappeared.

The building has housed the Sigmund Freud museum since its opening in 1971, in the presence of Anna Freud, operated by the Sigmund Freud Society. The museum occupies the entire first floor of the building that remained the Freud family residence for nearly fifty years. But it was only with the opening of the museum that the building, which receives nearly forty thousand visitors a year, has assumed its rightful place in the cultural life of Europe.

INGRID SCHOLZ-STRASSER

*See also:* Austria; Freud, Sigmund Schlomo; Sigmund Freud Museum; Wiener psychoanalytische Vereinigung.

### **Bibliography**

Engelman, Edmund. (1993). *Berggasse 19, Sigmund Freud's home and offices, Vienna, 1938, the photographs of Edmund Engelman*. New York: Basic Books.

Leupold-Löwenthal, Harald, Lobner, Hanz, and Scholz-Strasser, Inge. (1994). *Sigmund-Freud Museum Katalog*. Vienna: Christian Brandstätter.

---

## **BERGLER, EDMUND (1899–1962)**

Edmund Bergler, a major Freudian theoretician and clinician, was born in Austria on July 20, 1899, and died in New York City on February 6, 1962. Bergler received his medical degree from the University of Vienna in 1926, and married Marianne Blumberger in 1929. He served on the staff of Freud's clinic in Vienna from 1927–1933, and was an assistant director there from 1933–1938, when he moved to the United States. A prolific speaker and writer, he published nearly three hundred papers and twenty-four books, as well as lecturing and giving interviews.

Bergler's contribution to psychoanalytic thought was remarkable. He extended and made clinically usable several of Freud's later concepts, including superego

cruelty, unconscious masochism, and the importance of the pre-oedipal oral mother-attachment. Hitschmann spoke of his "extraordinary talent for the specialty of psychoanalysis . . . his command of the entire subject matter, his scientific acumen and literary erudition." Considered "one of the few original minds among the followers of Freud," Bergler presented his main ideas in *The Basic Neurosis*, in which he summarized his massive original contribution to the field.

Throughout his considerable body of written work, lucid case summaries in each book reveal clinical brilliance and a highly effective analytic technique. His own writing, as well as productive collaborations with Jekels, Eidelberg, Winterstein, and Hitschmann, included works on theory and technique. The Edmund and Marianne Bergler Psychiatric Foundation, in New York City, was established by Mrs. Bergler to preserve and perpetuate his work. It holds title to his working correspondence, many more articles, another two dozen complete books in English or German, as well as hundreds of drafts of papers and books, and will be a lasting resource.

MELVYN L. ISCOVE

*See also:* Superego; Unconscious, the.

### **Bibliography**

Bergler, Edmund. (1949). *The basic neurosis. Oral regression and psychic masochism*. New York: Grune and Stratton.

———. (1969). *Selected papers of Edmund Bergler, M.D., 1933–1961*. New York: Grune and Stratton.

———. (1982). *Counterfeit-sex*. New York: Grune and Stratton.

———. (1989). *The superego*. Madison, WI: International Universities Press.

———. (1992). *Principles of self-damage*. Madison, CT: International Universities Press.

———. (1993). *Curable and incurable neurotics*. Madison, CT: International Universities Press.

Hitschmann, Eduard, and Bergler, Edmund. (1936). *Frigidity in women*. Washington, New York: Nervous and Mental Disease Publishing Company.

**BERLIN PSYCHOANALYTIC INSTITUTE.** *See*  
**Berliner Psychoanalytisches Institut**

**BERLIN PSYCHOANALYTIC POLYCLINIC.** *See*  
**Berliner Psychoanalytische Poliklinik**

### **BERLINER PSYCHOANALYTISCHE POLIKLINIK**

When the Berlin Psychoanalytic Institute opened the first psychoanalytic polyclinic on February 14, 1920, it became the institutional model for bringing together the functions of therapy, research and training in one unit.

The Berlin Psychoanalytic Polyclinic fulfilled one of the functions of the Berlin Psychoanalytic Institute (polyclinic, teaching, course commission, treasury, and subsidies). The polyclinic committee consisted of Max Eitingon (reception of patients and treatment indications), Ernst Simmel (experience treating war neuroses) and Karl Abraham (President of the Berlin Association). Situated since 1928 at Wichmannstrasse 10 (with five consultation rooms and a library), the polyclinic was the property of Max Eitingon. In 1928 five assistants were treating between ten and twelve patients.

The antinomy creating tensions between therapy (continuing analysis in difficult cases) and teaching (giving “easy cases” to trainee analysts) led to the development of controlled analyses and technical seminars (no more than six participants and constant personal contact with the training analyst). Training analyses were not paid for. Members of the German Psychoanalytic Society (DPG) had to treat at least one case from the polyclinic. Fees: the patient’s own maximum; about two thirds of the patients were economically challenged and were treated free of charge. Sometimes health insurance funds paid part of the costs (psychologists: three Reichsmarks, physicians: five Reichsmarks). The average duration of treatment was about two hundred hours (in four or five weekly sessions of forty-five minutes).

In spite of the pressure from patients on the polyclinic’s waiting list, “short therapies” were rejected as

“failures.” What Freud had prophesied in Budapest that “the large-scale application of our therapy will compel us to alloy the pure gold of psychoanalysis,” did not apply, according to Eitingon “because we have no other metal to make such an alloy.” In eight and a half years there were 1,600 demands for cures, 640 of which were implemented. An average of 72 cases were treated per year at the polyclinic between 1920 and 1930 by 94 therapists, 60 of whom were API members. In spite of growing recognition from public authorities, the reaction from professional psychiatrists and psychologists was one of distrust because of the question of “lay analysis.”

In 1929 there were polyclinics in Vienna, London, Budapest and Paris. Following the forced elimination of Max Eitingon by the Nazis, Felix Boehm became President of the DPG in 1933 and director of the polyclinic. In 1935 the name of the polyclinic had to be changed by official order to “Ambulatorium.” The demand for treatment nevertheless remained constant. Following the forced expulsion of Jewish psychoanalysts from the DPG (December 1935) and their emigration, many courses of treatment were interrupted. The seventeen remaining “Aryan” analysts (February 1937) were still conducting forty-two analyses. With the creation of the *Deutsches Institut für Psychologische Forschung und Psychotherapie* (Göringinstitut) in May 1936, other methods of treatment were introduced and the organization was divided into four departments (diagnostics, training support, criminal psychology, assessment and catamnesis). Financing was provided by the *Deutsche Arbeitsfront* (DAF; the German Work Front), the *Reichsforschungsrat* (RFR; the Reich’s Research Council), the city of Berlin, the *Reichsluftfahrtministerium* (the Reich’s Ministry for Aviation) and health insurance funds. The goals pursued before the Nazis took over: “to enable psychoanalysis to penetrate the working classes” with the specific aim of effecting a profound change in people, were replaced at the Göring Institute by “the capacity to work.”

After the war Harald Schultz-Henecke and Werner Kemper founded the *Zentralinstitut für psychogene Erkrankungen* on March 1, 1946, with the support of individual insurance companies and pension schemes (VAB), offering a therapy financed by the state with psychoanalysts who were employed full-time, whether physicians or non-physicians. With the reorganization

of health insurance funds in 1958 it became the *Institut für psychogene Erkrankungen* (“Institute for Psychogenic Affections” for the Berlin general health insurance fund [AOK]). The trend toward short therapies and the separation from analytic training institutes meant there was no longer any functional continuity with the polyclinic. Both the DPG and the DPV instituted schools for transmitting psychoanalysis and psychotherapy without monthly wage-earning collaborators.

REGINE LOCKOT

*See also:* Abraham, Karl; Alexander, Franz Gabriel; Berliner Psychoanalytische Poliklinik; Eitingon, Max; Fenichel, Otto; Germany; “Lines of Advance in Psychoanalytic Therapy”; Sachs, Hanns; Simmel, Ernst; Technique with adults, psychoanalytic; Training analysis; Training of the psychoanalyst

### **Bibliography**

- Collectif. (1930). *Zehn Jahre Berliner psychoanalytisches Institut (1930)*. Wien: Internationaler psychoanalytischer Verlag.
- Freud, Anna. (1929). Korrespondenzblatt des Internationalen psychoanalytischen Verlags. *Internationale Zeitschrift für Psychoanalyse*, 25 (4), 509–542.
- Göring, Matthias H. (1942). Jahresbericht 1941 des Deutschen Instituts für psychologische Forschung und Psychotherapie und Hinweise anlässlich der Mitgliederversammlung am 28.3.1942. *Zentralblatt für Psychotherapie*, 14 (1–2), 62–77.
- Lockot, Regine. (1985). *Erinnern und Durcharbeiten: zur Geschichte der Psychoanalyse und Psychotherapie im Nationalsozialismus*. Frankfurt am Main: S. Fischer.

## **BERLINER PSYCHOANALYTISCHES INSTITUT**

The Berliner Psychoanalytisches Institut (Berlin Psychoanalytic Institute, or BPI), so named on February 20, 1922, included a polyclinic, a training institute (with lectures, case study seminars, and training and control analyses), a curriculum committee, and a treasury and finance office.

As early as 1919 Max Eitingon and Ernst Simmel proposed that the Berlin Psychoanalytic Society

establish a clinic offering free analytic treatment to those otherwise unable to afford it. This was a desideratum for Freud (1919a), and by the next year a training institute for such a clinic opened, with Simmel as director and Eitingon as owner, funded by an annual budget of about 16000 RM.

Located at 29 Potsdamerstrasse, the institute was managed by Ernst Freud. When it opened on February 14, 1920, it included lecture rooms, offices for consultation, and a library. Karl Abraham was in charge of the first courses. In the autumn of 1928, the institute moved to larger quarters at 10 Wichmannstrasse.

To counter the growing popularity of “wild analysis” and courting respectability in the eyes of the medical establishment, regulations were developed during 1923–1924 that governed acceptance of candidates (after three preliminary interviews), decided on the curriculum and role of training and control analyses, and also ruled on formal membership admissions. Medical studies (even if unfinished) were demanded of analysts-in-training; pedagogical studies were required for child analysts. Non-physicians in Germany enjoyed relative freedom to practice therapy. Thanks to Felix Boehm, the treasury was subsidized by members of the institute and money was available to support candidates. The monthly cost of training ranged from 200 to 300 RM.

Analytic training began with a didactic analysis (six months minimum) with indications as to treatment decided by the analyst-in-training committee. Theoretical teaching was the responsibility of the training analyst. After at least two semesters of theoretical studies, the candidate undertook at least two years of practical work at the polyclinic; this period would come to be known as “control” or “supervision” and was followed by transition to autonomous clinical work with approval of the training committee. Hanns Sachs described the training experience as a “novitiate” that was run like a “technical seminary.” Reacting against regimentation, a group of rebellious young analysts founded what became known as the “Kinderseminar” (Children’s Seminar).

The institute also trained non-therapeutic analysts who were permitted to attend all but technical courses on treatment. Members of groups from Frankfurt, Stuttgart, Leipzig, and Hamburg attended workshops and conferences at the BPI.



In 1930, ninety-four therapists worked at the BPI, sixty of whom belonged to the International Psychoanalytic Association (which then totaled four hundred). The Prussian-like hierarchical structure was criticized by Siegfried Bernfeld as damaging to psychoanalysis. The BPI acquired a reputation for rigidity that was exported through emigration and escape from Germany during the Nazi era. A detailed report published in 1930 on the institute's tenth anniversary allows a better understanding of the training system that would become the basis for standards set by the International Psychoanalytic Association (Colonomos).

Institutes modeled after the Berlin Psychoanalytic Institute were soon founded in Vienna, London, Budapest, The Hague, Frankfurt, New York and Chicago, and Paris (in 1934 and again in 1954). Other institutes in the United States based on the BPI were established in Philadelphia, Boston, Detroit, Topeka, San Francisco, Washington, D.C., Los Angeles, Seattle, Denver, and New Orleans.

A wave of voluntary emigration brought Melanie Klein and Walter Schmilberg to Britain, and Franz Alexander, Jenő Hárnik, Sándor Radó, Karen Horney, and Hanns Sachs to the United States. Among the most influential of some seventy-four analysts and candidates-in-training obliged to leave Germany were Siegfried Bernfeld, Max Eitingon, Otto Fenichel, Wilhelm Reich, Theodor Reik, and Ernst Simmel.

The number of students at the BPI, some two-hundred twenty-two strong in December 1931, declined steeply after the National Socialists came to power, with only thirty-nine in attendance in December 1933; the number of analytic candidates fell from thirty-four in the fall of 1932 to eight in July 1934. The demand for treatment remained constant, however. In 1935 there were still fourteen analysts in Germany. A series of state interventions, forced resignation of Jewish analysts, and concessions made by the remaining "Aryan" analysts, including the "aryanization" of the directorate, damaged the institute from without and drained it from within. Both the treasury and committee meetings, as well as conceptual terminology of psychoanalysis, came under state control. The BPI was renamed the German Institute of Psychoanalysis, and all the institute's assets were transferred "on loan" to the German Institute for Psychological Research and Psychotherapy (*Göringinstitut*, or Göring Institute), founded in 1936.

After the war, in 1950, the Karl Abraham Institute, established in association with the German Psychoanalytic Association (DPV) and directed by Carl Müller-Braunschweig, renewed the tradition of the BPI.

REGINE LOCKOT

*See also:* Abraham, Karl; Alexander, Franz Gabriel; Berliner Psychoanalytische Poliklinik; Eitingon, Max; Fenichel, Otto; Germany; "Lines of Advance in Psychoanalytic Therapy"; Sachs, Hanns; Simmel, Ernst; Technique with adults, psychoanalytic; Training of the psychoanalyst.

### **Bibliography**

- Bernfeld, Siegfried. (1984). Über die psychoanalytische Ausbildung. *Psyche*, 38, 437–459.
- Colonomos, F. (Ed). (1985). *On forme des psychanalystes: rapport original sur les dix ans de l'Institut psychanalytique de Berlin, 1920–1930*. Paris: Denoël.
- Eitingon, Max. (1924). Bericht über die Berliner psychoanalytische Poliklinik—Juni 1922–März 1924, VIIIer Internationalen psychoanalytischen Verlags-Kongress. *Internationale Zeitschrift für Psychoanalyse*, X (2), 229–241.
- Freud, Sigmund. (1919a). Lines of advance in psychoanalytic therapy. *SE*, 17: 157–168.

### **BERMAN, ANNE (1889–1979)**

Anne Berman, a French pharmacist, was the personal secretary of Marie Bonaparte and a translator of psychoanalytical works. She was born March 23, 1889, and died April 25, 1979. After her dissertation, "La Famille des Boraginacées" (The Family of Boraginaceae), was completed, she worked in the laboratory of Dr. Toulouse at the Sainte-Anne hospital until 1924. That year the Souffron pharmacy on 54, rue de Miromesnil went up for sale. She bought the pharmacy, where she worked for several years. She was a pharmacist delegate to the Chambre Syndicale and, on May 22, 1928, was accepted as a member of the Soroptimists, an organization founded in California in 1921 with the goal of recruiting women who excelled in their profession.

After undergoing analysis with Marie Bonaparte, she became her secretary. She was accepted as the first member of the Paris Psychoanalytic Society on January

10, 1927. She administered the secretariat of the Institut de Psychanalyse (Psychoanalysis Institute) from its inception in 1934.

She translated several of Freud's work including *Psychoanalytic Procedure*, *An Outline of Psychoanalysis*, the first two volumes of Ernest Jones's *Life and Work of Sigmund Freud*, Anna Freud's *The Ego and the Mechanisms of Defense*, and *The Birth of Psychoanalysis, Letters to Wilhelm Fliess*.

At the time of Berman's death, Serge Lebovici wrote, in the *Revue française de psychanalyse*: "A tireless reader, a musician who was especially fond of Wagner, Annette remained a close friend of the psychoanalysts of her generation and was able, because of this, to contribute to a history of the birth of psychoanalysis in France. In spite of her discretion, we will remember her as among those who did the most to spread the knowledge of Freud's work in France."

JEAN-PIERRE BOURGERON

See also: Bonaparte, Marie Léon; Borel, Adrien Alphonse Alcide; France; *Revue française de psychanalyse*; Société psychanalytique de Paris and Institut de psychanalyse de Paris.

### Bibliography

Lebovici, Serge. (1979). Anne Berman. *Revue française de psychanalyse*, 43 (3), 476.

---

**BERNAYS-FREUD, HANNA.** See **Freud, Sigmund (siblings)**

---

### BERNAYS-FREUD, MINNA (1865–1941)

The younger sister (by four years) of Martha Bernays, Sigmund Freud's wife, Minna Bernays was born June 18, 1865 (June 16 according to some sources), in Hamburg and died February 13, 1941 in London. She was the youngest of seven children, the daughter of Jewish businessman Berman Bernays (1826–1879) and Emmeline Philipp (1830–1910). Three children died while still young—Fabian, 1857, Michel, 1857–1859, and Sara, 1858–1859—the eldest brother (Isaak, 1855–1872) died at the age of seventeen from a bone infection presumed to be of tubercular origin. The father

was the third son of the rabbi (*chacham*) Isaak Bernays (1793–1849). Both of his brothers were distinguished men: Jacob (1824–1881) was a philologist and Michael (1834–1897) was an expert on literature. The mother was from a well-to-do family, originally from Sweden on the father's side, and from Hamburg on the mother's side.

When Minna was four years old, in 1869, the Berman family moved from Hamburg to Vienna after the father finished serving a four-year jail sentence for bankruptcy fraud. In Vienna, Berman Bernays worked as a secretary for the economist Lorenz von Stein and as a writer for the *Zentralblatt für Eisenbahnen und Dampfschiffahrt* (Rail and Steamship Transport Journal). Nothing is known about Minna Bernays's childhood and education. When her father died in December 1869, she was brought up by her mother and Sigmund Pappenheim, the father of Bertha Pappenheim, the woman made famous by Breuer as Anna O.

In 1882–1883 Minna spent several weeks in Sicily because of pulmonary tuberculosis. On February 18, 1882, at the age of seventeen, she became engaged to Ignaz Schönberg, a student in the philosophy department at the University of Vienna, who was studying with Georg Bühler, the orientalist. Schönberg received his doctorate on May 12, 1884, and was appointed to the Indian Institute at Oxford, a position that had been offered to him by Monnier Williams, the editor of a Sanskrit dictionary. He contracted tuberculosis, however, and had to resign his position in February 1885, and broke off his engagement to Minna in June. After leaving Great Britain in August, he returned to Meran, near Vienna, where he spent the winter. He died in early February 1886, in Vienna.

From 1883 to 1895 Minna Bernays spent most of her time in Hamburg with her mother, who was ill. For short periods of time she worked as a companion and children's tutor; she also participated in a workshop for manual crafts, like the one run by Freud's sister Rosa. In November 1885 she spent a few months with Freud (November 29, 1895, according to Wilhelm Fliess). In March 1896 she obtained a position in Frankfurt (March 7, 1896), but in June she quit and moved in permanently with her sister's family; she remained here for the rest of her life, except for the brief periods of time she spent away on holiday or for health reasons.

In Martha's absence she ran the house, took care of the children, cooked, and made handicrafts. She served as host to Freud's guests and students, handled some of his correspondence, played mahjong and tarot with him, and corrected his manuscripts.

In 1887 Freud undertook a voyage of several days, or several weeks, with Minna to various resorts and rest homes in Bavaria and northern Italy. They traveled by foot, by coach, and by train, visiting the southern Tyrol and the Engadine, while Freud's wife rested with the children. In general, Freud's vacations with his wife were less adventurous. Minna often accompanied Freud's children on their summer vacations to Berchtesgaden, Reichenhall, or Aussee.

In May 1938, a few weeks before Freud, Martha, and Anna, Minna emigrated to Great Britain, for, unlike her sister, she had retained her German citizenship. She died there three years later from heart disease.

According to descriptions of her from letters and personal recollections, Minna was an intelligent woman with a lively personality and a sense of humor, who read German and English. On occasion she could be highly sarcastic and inaccessible, caustic at times, with a kind of Germanic stiffness. She was often ill, and suffered from migraines, digestive, cardiac, and eye problems. Her tuberculosis required additional treatment in 1900.

Sigmund Freud's relationship to Minna Bernays has given rise to considerable speculation (see the Freud-Ferenczi correspondence of December 16, 1912). In 1957 Carl Gustav Jung stated in an interview that Minna had mentioned a sexual relationship between her and Freud (Billinsky, J. M., 1969), but Jung's claim has little credibility. Similarly, the attempts to find proof in the *Interpretation of Dreams* or the *Psychopathology of Everyday Life* of intimacy between Freud and Minna are not convincing (Swales, P., 1982). The remaining correspondence, approximately two hundred letters from different periods between 1882 and 1938, provide no indication of such a relationship. The letters do demonstrate the existence of a strong bond between them, which Freud confirmed to Marie Bonaparte, telling her that at the time of his relative isolation, Wilhelm Fliess and Minna Bernays were his only friends.

Unlike Martha, Minna remained close to Jewish traditions. She was the only member of the family who refused to be cremated. Few traces of her personal papers remain. But the Sigmund Freud Museum in London houses several examples of handicrafts made by her.

ALBRECHT HIRSCHMÜLLER

See also: Berggasse 19, Wien IX; Freud-Bernays, Martha.

### **Bibliography**

- Billinsky, John M. (1969). Jung and Freud: The end of a romance. *Andover Newton Quarterly*, 62, 2, 39–43.
- Freud, Sigmund. (1960a). *Letters of Sigmund Freud, 1873–1939* (Ernst L. Freud, Ed.; Tania and James Stern, Trans.). London: Hogarth Press.
- . (1985). *The complete letters of Sigmund Freud to Wilhelm Fliess 1887–1904* (Jeffery M. Masson, Ed., Trans.). Cambridge, MA: Belknap/Harvard University Press.
- Freud, Sigmund, and Ferenczi, Sándor. (1999–2000). *The correspondence of Sigmund Freud and Sándor Ferenczi* (Eva Brabant, Ernst Falzeder, and Patrizia Giampieri-Deutsch, Eds.; Peter T. Hoffer, Trans.). Cambridge, MA: Belknap/Harvard University Press.
- Swales, P. J. (1982). Freud, Minna Bernays, and the conquest of Rome. New light on the origins of psychoanalysis. *New American Review*, 1–23.

### **BERNFELD, SIEGFRIED (1892–1953)**

An Austrian philosopher and psychoanalyst, Siegfried Bernfeld was born March 7, 1892, in Lemberg, the capital city of Galicia, and died April 2, 1953, in San Francisco. Bernfeld distinguished himself in the extent of his knowledge, the originality of his ideas, and his qualities as an educator. A prolific and exacting writer, he was also an outstanding teacher, admired by his students and respected by his colleagues. Freud said he considered him the most gifted of his students and disciples.

His parents lived in Vienna but his mother returned to her hometown to give birth to her first child. In 1910 Bernfeld completed his studies at the Gymnasium and entered the University of Vienna, where he obtained a Ph.D. in philosophy, while also studying psychoanalysis, sociology, education, and biology. All branches of knowledge held an interest

for Bernfeld, who was also involved in contemporary political issues. A lucid and passionate left-wing Zionist, he was active in political struggles while he was a university student.

Impregnated with the ideas of psychoanalysis and Marxism, Bernfeld founded, in 1919, the *Kinderheim Baumgarten*, where nearly three hundred Jewish children, refugees from Poland, were housed. His first book, published in 1921, examined this short, intense period of his life.

In 1925 he published two important works on infant psychology and education. *Psychologie des Säuglings* (Infant Psychology) is a well-known work that makes use of psychoanalysis and drive theory to develop a new psychology of the infant. *Sisyphos* is a critique of the idealist notion of education and comes down strongly in favor of a non-authoritarian system, one that respects the life of the instincts and the needs of the student.

Attracted by the fame of Max Eitingon's institute, Bernfeld traveled to Berlin in 1926. There he underwent analysis with Hanns Sachs and rapidly won the admiration of his students. While there he studied the scientific foundations of psychoanalysis and, returning to his first love, biology, researched the theory of instincts. At the end of his Berlin period, he contrasted his position (as a Freudian and Marxist) with that of Wilhelm Reich in two important articles, and wrote an essay on interpretation.

In *Der Begriff der "Deutung" in der Psychoanalyse* (The Concept of "Interpretation" in Psychoanalysis), Bernfeld described the concept of interpretation with the tools of the scientific method, something he shared with Moritz Schlick and Hans Reichenbach. He distinguished several types of interpretation. "Final" interpretation attempts to penetrate the unconscious intentional context in which a determinate psychic production that appears to be isolated from any context can be situated. "Functional" interpretation takes account of the value of a specific psychic fact. "Reconstruction," an instrument of psychoanalytic science, concretely reconstructs an old psychic process. Because there is a consistent relation between the psychic event and its traces, reconstruction can discover the genetic connection that is continuously repeated through impulse and desire. In this way psychoanalysis is raised to the rank of a natural science to the extent

that it provides an explanation for personal psychic events on the basis of certain laws.

The approach to psychoanalysis as a science of traces is based on the leading theories of the field: free association, transference and resistance, which inhibits the formation of missing unconscious connections (Bernfeld returns to this subject in 1941 in *The Fact of Observation in Psychoanalysis*, a work that exercised considerable influence on his disciples in California, especially Edward M. Weinschel).

With the collapse of the Weimar Republic and the imminent ascent of Hitler to power, Bernfeld realized that he could no longer remain in Germany. He left Berlin and, after a brief stay in Vienna, went into exile in France in 1932.

Little is known about Bernfeld's life in France. Apparently, he was not well received by the Paris Psychoanalytic Society. He settled in the south of France, where he met Suzanne Cassirer-Paret, who became his third wife and an important collaborator. In 1936 Siegfried and Suzanne decided to leave France and, in answer to Otto Fenichel and Ernst Simmel's invitation, emigrated to California in 1937. In San Francisco Bernfeld resumed his teaching activities and wrote, together with his wife, a series of articles that can be considered the point of departure for "Freudology." These include a documented study on the Helmholtz School (1944) and a 1946 essay in which Bernfeld discovers that the enigmatic character in "Screen Memories" (Freud, S., 1899) is no other than Sigmund Freud himself. There followed several articles on Freud's early scientific work, his studies on cocaine, and, together with his wife, an article on the childhood of the founding father of psychoanalysis and his first years in practice. Bernfeld died in 1953 while he and his wife were preparing other articles on Freud's life.

R. HORACIO ETCHEGOYEN

*See also:* Lehrinstitut der Wiener psychoanalytischen Vereinigung; Marxism and psychoanalysis; North America; Screen memory; Wiener psychoanalytischen Vereinigung; Zeitschrift für psychoanalytische Pädagogik.

### **Bibliography**

Bernfeld, Siegfried. (1921). *Kinderheim Baumgarten. Bericht über einen ernsthaften Versuch mit neuer Erziehung*. Berlin: Jüdischer Verlag.

———. (1929). *The psychology of the infant*. New York: Brentano.

———. (1925). *Sisyphos, oder die Grenzen der Erziehung*. Vienna: Internationaler psychoanalytischer Verlag.

———. (1932). Der Begriff der “Deutung” in der Psychoanalyse. *Zeitschrift für angewandte Psychologie*, 4, 448–497.

Ekstein, Rudolph. (1968). In Fr. Alexander, S. Eisenstein, M. Grotjahn (Eds.), *Psychoanalytic pioneers*. New York, London: Basic Books.

## BERNHEIM, HIPPOLYTE (1840–1919)

A professor of ambulatory health care at the department of medicine in Nancy, Hippolyte Bernheim was born in Mulhouse on April 27, 1840, and died in Paris on February 2, 1919. He studied medicine in Strasbourg and, when he received his degree in 1870, during the Franco-Prussian war, he decided to practice in France. In 1879 he was offered the chair of ambulatory medicine at the then-new department of medicine in Nancy. Around 1882, in spite of his initial reticence, he agreed to visit Ambroise Liebeault’s “clinic.” Convinced of the efficacy of Liebeault’s methods, Bernheim began to use hypnosis on some of his patients, generally working with people suffering from a variety of infectious diseases. In 1884 he published a scathing attack on the Salpêtrière: hysteria and hypnosis were no more than cultural phenomena aroused by the power of suggestion.

Bernheim now became the spokesman of a new school that was internationally recognized. In his private practice he saw neurotic patients from all over Europe. In spite of his personal admiration for Jean Martin Charcot, his position was deepened and further radicalized in two books translated by Freud, *De la suggestion et de ses applications à la thérapeutique* (Suggestion and its Therapeutic Applications) (1886 and 1888) and *Hypnotisme, suggestion, psychothérapie* (Hypnotism, Suggestion, Psychotherapy) (1891 and 1903). The prevalence of Bernheim’s position seems to have exhausted itself by the end of the century. Charcot himself, at the end of his life, in *La foi qui guérit* (The Faith that Heals) (1892), appears to have moved closer to the position of the school of Nancy. However, in Nancy, Bernheim felt isolated. He distanced himself from Liebeault, his hypnosis practice began to disintegrate, and his support for Dreyfus aroused considerable anti-Semitic hostility. After retiring in 1910 Bernheim moved to Paris. In 1913, in a book on

hysteria, he gave a favorable assessment of the *Studies on Hysteria*.

According to Bernheim, hypnosis is only a particular case of the psychological phenomenon of suggestion. Psychotherapy—a term Bernheim popularized—incorporated the power of language, the doctor’s influence on the patient, and the effect of the patient’s mind on his body. Bernheim argued for a therapy of and by the mind, which could cure nervous illnesses and suppress or calm the symptoms, even the causes, of organic disease. He seems to have been a flexible and eclectic therapist, passing when necessary from authoritarianism to insinuation, sometimes even refusing to give orders to his patients.

Shortly before the July 1889 Congress on Hypnotism held in Paris that year, Sigmund Freud came to see Bernheim in Lorraine. In a letter to August Forel, Bernheim referred to Freud as a “charming young man.” In 1888 however, Freud had turned to Charcot for support in criticizing Bernheim. After 1889 Freud would make use of some of Bernheim’s ideas to distance himself from Charcot, but he continued to remain critical of the theory of suggestion promulgated by the school of Nancy. Freud later recalled how forcefully certain experiments of 1889, involving the recall of memories originating during hypnosis, had struck him. Reading the text published in 1890 after his trip to Lorraine, the “insightful” clinician from Nancy may also have left Freud with the nucleus of an idea for the treatment of the “psyche,” or “soul,” and an interest in the magic of words.

JACQUELINE CARROY

See also: Autosuggestion; Cécilie M., case of; Hypnosis; Liebeault, Ambroise Auguste; Negative hallucination; Suggestion; Translation.

### Bibliography

- Bernheim, Hippolyte. (1903). *Hypnotisme, suggestion, psychothérapie* (2nd ed). Paris: Fayard, 1995.
- Blum, J.-L. (1986). *La vie d’Hippolyte Bernheim, 1840–1919* (pp. 103–117). Paris: Frénésie.
- Carroy, Jacqueline. (1988). L’école hypnotologique de Nancy. I: Liébeault, Beaunis, Liégeois et Delbœuf. II: Bernheim, Charcot et Freud, le Pays lorrain. *Journal de la Société d’archéologie lorraine et du Musée historique lorrain*, 2–3, 108–116; 159–166.

Delboeuf, Joseph. (1885). *Le Sommeil et les Rêves*. Paris: Félix Alcan; *Le Sommeil et les Rêves et autres textes*. Paris: Fayard, 1993.

Freud, Sigmund. (1890a). *Psychical (or mental) treatment*. *SE*, 7: 283–302.

## BETA-ELEMENTS

In his paper, “A Theory of Thinking” (*Second Thoughts*, 1967, pp. 100–120), Wilfred Bion speaks of raw sense-data and of “inchoate elements” which have to be transformed into alpha-elements by alpha functions. That description is the precursor of what he was to call later *beta-elements*. He first uses the term *beta-elements* in *Learning from Experience*: “If alpha-function is disturbed and therefore inoperative the sense impressions of which the patient is aware and the emotions which he is experiencing remain unchanged. I shall call them *beta-elements*. In contrast with the alpha-elements the *beta-elements* are not felt to be phenomena, but things in themselves” (p. 6).

Bion often speaks of *beta-elements*, raw sense-impressions, and raw emotional data. *Beta-elements* are very concrete. They are felt as bad internal “things” which can be dealt with only by expulsion. He emphasizes that the *beta-function* emotions are also experienced as physical objects.

This is an extension of Klein’s view that the infant experiences hunger as a bad internal breast that has to be expelled. It is important to keep this in mind, because otherwise some of Bion’s statements may seem contradictory, because he speaks of sense data that have to be expelled, but on many occasions he refers to the fear of death (hardly a sense-datum), which has to be expelled and projected into the breast. But for the infant at that stage, hatred and fear are experienced as bad objects. The experience is confused with the object responsible for the experience. In *Elements of Psycho-Analysis* (1963), Bion provides the following model: “[The infant] ... filled with painful lumps of faeces, guilt, fears of impending death, chunks of greed, meanness and urine, evacuates these bad objects into the breast that is not there. As it does so the good object turns the no-breast (mouth) into a breast, the faeces and urine into milk, the fears of impending death and anxiety into feelings of love and generosity ... The mechanism is implicit in the theory of projective identification in which Melanie Klein formulated her discoveries of infant mentality.”

*Beta-elements* can be dealt with only by expulsion. They are not material for thought, but underlie acting-out, hallucinations, and delusions. When *beta-elements* are projected into the mother they can be transformed into *alpha-elements*, which are elements of dream and thought, by the *alpha-function*. The nearest clinical approximations to raw *beta-elements* are bizarre objects. *Beta-elements* do not combine with one another in an integrated way, but they can become accumulated. When this happens the contact-barrier becomes a *beta-screen*. Unlike *alpha-elements*, *beta-elements* are saturated: they are not open to change by new impressions, and therefore not open to reality-testing. They can be only transformed by *alpha function*.

HANNA SEGAL

*See also:* *Alpha function*; *Alpha-elements*; Bion, Wilfred Ruprecht; *Concept*; *Contact-barrier*; *Grid*; *Learning from Experience*; *Maternal reverie*, capacity for; *Object*; *Primary object*; *Primal, the*; *Protothoughts*; *Psychotic panic*; *Idea/representation*; *Reverie*; *Symbolic equation*; *Transformations*.

### Bibliography

Bion, Wilfred R. (1962). *Learning from experience*. London, Heinemann; New York: Basic Books.

———. (1963). *Elements of psycho-analysis*. London: Heinemann.

———. (1967). *Second thoughts*. London: Heinemann.

## BETA-SCREEN

Bion first mentioned a *beta-screen* in his description of the contact-barrier in *Learning from Experience* (pp. 17–23, 1962). A *beta-screen* forms when there is a deficiency in *alpha-functioning* and *beta-elements* replace the contact-barrier.

When a *beta-screen* is formed there is no communication between the conscious and unconscious. Rational thought up to a point can exist, but cut off from emotional meaning. A *beta-screen* forms an impenetrable barrier. It is a defense against any meaningful emotional experience. As the *beta-screen* is composed of *beta-elements* which lend themselves to projective identification, it also manifests itself in a bombardment directed both against the *alpha-*

functioning of the patient himself and against any external object susceptible to arousing meaningful feelings. In analysis, the patient bombards the analyst with confused fragmentary material imbued with violence and directed against the analyst's attempt to get in touch with an emotionally significant experience.

HANNA SEGAL

*See also:* Beta-elements; Contact-barrier.

### ***Bibliography***

Bion, Wilfred R. (1962). *Learning from experience*. London: Heinemann; New York: Basic Books.

———. (1963). *Elements of psycho-analysis*. London: Heinemann.

---

## **BETTELHEIM, BRUNO (1903–1990)**

The psychoanalyst and educator Bruno Bettelheim was born in Vienna on August 28, 1903, and died on March 13, 1990, in Silver Spring, Maryland.

The son of a wood merchant from the assimilated Jewish middle class, Bettelheim had to give up his studies when his father died of syphilis. He was twenty-three and remained scarred by his father's "shameful" death. He returned to his studies in philosophy ten years later and in February 1938 was one of the last Jews to earn a doctorate at the University of Vienna before the Anschluss. His thesis was entitled "The Problem of Beauty in Nature and Modern Esthetics" and was supervised by the famed Karl Bühler, director of the Institute of Psychology and a pioneer of *Sprachtheorie* (theory of language).

In 1930 Bettelheim had married a schoolteacher who was a disciple of Anna Freud, but he was unhappy. He saw reflected in his wife's eyes the ugliness that had obsessed him since he first saw it in his mother's eyes. In 1936 he entered analysis with Richard Sterba, then secretary of the Vienna Society and the only non-Jew on its Committee. At the time of the Anschluss, Sterba abruptly abandoned all his patients, preferring exile to the risk of being called upon by the Nazis to rid the society of Jews.

When Bettelheim was arrested by the Gestapo on May 29, 1938, he was thus in the midst of his analysis. The ten and a half months he spent in Dachau, and

later in Buchenwald, had a decisive influence on him. To escape madness, he studied the effects of the camps on the other prisoners, the prison guards, and himself. Whenever he could, he shared his observations with Paul Federn's son Ernst.

Bettelheim was liberated on April 14, 1939, and arrived in the United States three weeks later. He had lost everything. His wife left him. His first job was to devise a test for evaluating knowledge in the plastic arts that is still in use today. Between 1941 and 1944 he taught art history, German literature, and psychology. Above all, he sought to publish the article on the concentration camps that he had been working on since his release.

Rejected several times on the grounds that it was nonobjective or "anti-German," the article finally appeared in October 1943 in the journal of the Harvard psychology laboratory. "Individual and Mass Behavior in Extreme Situations" is a study of the deportees that makes particular use of Anna Freud's concept of "identification with the aggressor." In 1945, General Eisenhower had the article distributed to American officers in Europe, who were ill-prepared for the opening of the concentration camps.

In 1960 Bettelheim returned to this text in *The Informed Heart: Autonomy in a Mass Age*, the first book in which he made a connection between his experiences in the camps and the Freudian-inspired "milieu therapy" he established at the University of Chicago's Orthogenic School, of which he became director in 1944. This connection can be summarized as follows: Having witnessed mentally sound people go insane because of the effects of the camps, Bettelheim attempted to remedy the problems of severely disturbed children by creating an environment that was totally responsive to their needs and symptoms. This approach remained Bettelheim's trademark and established the reputation of his school worldwide.

In 1973 Bettelheim retired to California. He conducted seminars, supervised therapists in training, wrote, and was a sought-after lecturer. In 1984, the death of his second wife, who was also from Vienna and had borne him three children, plunged him into a deep depression that he struggled against for another six years, pursuing his activities despite health problems. After the publication of *Freud's Vienna and Other Essays* in January 1990, he moved to a retirement home near Washington, D.C. Two months later, he

committed suicide by ingesting barbiturates and, to ensure that he would not be “saved,” putting a plastic bag over his head. Fifty-two years earlier, on the same night, the Nazis had entered Austria to the cheers of a crowd shouting “Death to the Jews.”

Bettelheim was a good storyteller and popularizer of Freud’s ideas, and his books sold very successfully. He recounted his clinical experience in three books about the Orthogenic School, *Love Is Not Enough: A Treatment of Emotionally Disturbed Children* (1950), *Truants from Life* (1955), and *A Home for the Heart* (1974), and in *The Empty Fortress* (1967), which studies three cases of autism. With regard to theory, he was a maverick. He initially conceived of his school as “putting Freud’s concepts into action.” He then distanced himself from Freud to flirt with culturalism in *Symbolic Wounds: Puberty Rites and the Envious Male* (1954). After moving closer to the ego psychology that predominated at the Chicago Institute headed by Franz Alexander (*The Informed Heart*), he returned to Freud by way of the self-psychology advocated by his friend Heinz Kohut (*The Empty Fortress*), and he ended up writing a long polemical essay denouncing the ways in which Freud had been betrayed by his English translator, James Strachey (*Freud and Man’s Soul*, 1983). A careful reading of *Surviving and Other Essays* (1979), a collection of Bettelheim’s writings on Nazism, gives a glimpse of the painful self-analysis by which he continued, first in the camps and then for the rest of his life, the work that had been interrupted by the Anschluss.

*The Uses of Enchantment: The Meaning and Importance of Fairy Tales* (1976), a study of the role of fairy tales on the development of the unconscious, is Bettelheim’s best-selling book. He also wrote a book on education in the kibbutzim, *The Children of the Dream* (1969), and many other works on children’s education (*Dialogues with Mothers*, 1962; *A Good Enough Parent*, 1987; and numerous articles).

Bettelheim’s suicide was immediately followed by a furious scandal, with former patients and students denouncing him as a liar, a brute, and a despot who was all the more hypocritical because he had preached respect for children. Beyond what it reveals about the confusion ensuing from the suicide of such a man, this scandal is interesting because it goes to the heart of Bettelheim’s clinical genius: an almost infallible intuition about what causes a child to suffer and the ability

to confront his patient’s most destructive impulses. He often compared his role to that of a lightning rod, attracting lightning and thus proving that it had not killed anyone—not even him.

Too often catalogued as a specialist in autism, Bettelheim was above all a master teacher who continually succeeded in getting the therapists under his supervision and the educators in his school to recognize the part of themselves that was put at risk by their patients’ madness. That said, his depictions of the most disturbed students in his school, including some autistic patients, were so vivid, so focused on what these children were doing—and not on their deficiencies, as was common practice—that his work had a decisive influence on the way young psychotic patients are treated in psychiatric hospitals around the world.

NINA SUTTON

See also: Autism; Ego; *Empty Fortress*, *The*; Infantile schizophrenia.

### Bibliography

- Bettelheim, Bruno. (1960). *The informed heart: Autonomy in a mass age*. New York: Alfred A. Knopf.
- . (1990). *Freud’s Vienna and other essays*. New York: Alfred A. Knopf.
- Bettelheim, Bruno, and Karlin, Daniel. (1975). *Un autre regard sur la folie*. Paris: Stock.
- Jurgenson, Geneviève. (1973). *La Folie des autres*. Paris: Robert Laffont.
- Pollak, Richard. (1997). *The creation of Dr. B.: A biography of Bruno Bettelheim*. New York: Simon and Schuster.
- Raines, Theron. (2002). *Rising to the light: A portrait of Bruno Bettelheim*. New York: Alfred A. Knopf.
- Sutton, Nina. (1995). *Bruno Bettelheim: The other side of madness* (David Sharp, Trans.). London: Duckworth.

---

## BEYOND THE PLEASURE PRINCIPLE

*Beyond the Pleasure Principle* was presented by Freud as the “third step in the theory of drives.” The essay, which introduced the dynamic of the life and death impulses was “in gestation” on March 17, 1919. On May 12, Freud spoke with Sándor Ferenczi, stating “Not only have I completed *Beyond the Pleasure*



*Principle*, which I'll have recopied for you, but I have also returned to that little trifle on the uncanny and attempted ... to provide a  $\Psi$ A basis for group psychology." On April 2, he spoke of the essay to Lou Andreas-Salomé: "Where am I with my Metapsychology? First of all, it's not yet written... But if I live another ten years ... I promise to add other contributions. One of the first of this kind will be contained in *Beyond the Pleasure Principle*." The suffering of his friend Anton von Freund, whom Freud visited every day in the autumn of 1919, followed by the death of Freud's daughter Sophie in January 1920, interrupted the work. Completed between May and July, it was published in December. Chapter 6 was added in 1920 (Grubrich-Simitis, 1993) and, between 1921 and 1925, three subsequent editions came out, with a modified text. These were soon translated into English, Spanish (1922), and French (1927).

Returning to his metapsychological writings of 1915, Freud introduced the "pleasure principle," which he related to Fechner's principle of stability. The evocation of traumatic neurosis, children's games, repetition during the transference, and fate neurosis suggested a "more primitive," "more elementary," "more instinctual" tendency than the pleasure principle, independent of it and manifested by the repetition compulsion.

Unconvinced by his clinical studies, Freud introduced the "speculation that often looks far afield" (chapter 4). The topography and functions of the Pcs.-Cs, system were examined from the classical point of view, using the *Studies on Hysteria* (1895d) and *The Interpretation of Dreams* (1900a) as references. The protective shield function enabled him to define trauma from the vantage point of psychic economy and introduce the function of binding psychic energy that relates to the repetition compulsion.

Chapter 5 continued along these lines, then the referent changed: "But how is the predicate of being 'instinctual' related to the compulsion to repeat? At this point we cannot escape a suspicion that we may have come upon the track of a universal attribute of instincts and perhaps of organic life in general... It seems, then, that an instinct is an urge inherent in organic life to restore an earlier state of things which the living entity has been obliged to abandon under the pressure of external disturbing forces; that is, it is a kind of organic elasticity, or, to put it another way, the

expression of the inertia inherent in organic life." The essay continued to pursue this theme. Extrapolation from this led to the death instinct: the initial state of living being is inanimate matter deprived of energy, and the death instincts tend toward its reestablishment; the pleasure principle is at their service; the instincts of self-preservation too, because they tend to reestablish an earlier state.

The regressive and conservative functions of the sexual drives and their primal existence were less easy to analyze. An extensive investigation of biological research on death and reproduction followed (chapter 6), in which Freud equated the ego instincts with the death instincts, and the sex instincts with the life instincts. The myth related by Aristophanes in the *Symposium* led Freud to develop the hypothesis that, initially, living substance was "continuous." Eros attempts to reestablish this continuity by combining gametes. The death instinct, however, disunites organisms to achieve its goal, and instinctual conflict is established.

*Beyond the Pleasure Principle* created, through the use of an instinctual dualism that had been missing since the introduction of narcissism, a space for stylization of considerable dimension; its substrate is inanimate matter and living substance; its dynamics involve the primary tension in living things, external forces likely to be integrated, and internal tendencies leading to the reestablishment of an earlier state. In actual terms this space is "sufficient" for stylizing all the modes of stability of dynamic processes: from strict identity to instability, and including the flexible stability of living things. Freud incorporated earlier metapsychological investigations into his essay, and he provided Ferenczi with a pathway to future research. In addition to *Group Psychology and the Analysis of the Ego* (1921c), *Beyond the Pleasure Principle* served as a conduit to *The Ego and the Id* (1923b), Freud's "second topographic point of view." The relationship between the death instinct, hatred, and the destructive instinct led to their eventual reassessment and an analysis of sadomasochism. *Beyond the Pleasure Principle* served as an essential element and organizing principle for Freudian psychoanalysis.

Because it was difficult, the essay was often poorly received and misunderstood. This attitude was typified by Ernest Jones (1953–57, III), unlike that of Sándor Ferenczi, who had anticipated the theme in 1913. The

death drive has either been rejected or reduced to destructive drives (Melanie Klein), or made to serve as a justification for a structuralist viewpoint (Jacques Lacan). Jean Laplanche (1970) highlighted the problems and paradoxes in the essay, including the chiasmus that transforms the sex drives, disturbing and pathogenic, into Eros, life's only safeguard.

The "inherent thrust toward organic life, to the reestablishment of an earlier state," can be separated into various dynamics and types of stability through the use of qualitative dynamics (Porte, 1994), and through them we can better understand the aptness of Freud's questions and the magnitude of his efforts.

MICHÈLE PORTE

*See also:* Automatism; Death instinct (Thanatos); Drive/instinct; Eros; Fort-Da; Fusion/defusion; Fusion/defusion of instincts; Life instinct (Eros); Masochism; Moral masochism; Nightmare; Pleasure/unpleasure principle; Primary masochism; Repetition compulsion; Symbolic, the; Trauma.

#### Source Citation

Freud, Sigmund. *Jenseits des Lustprinzeps*. Leipzig-Vienna-Zurich (1920). *GW*, 13, 1–69; Beyond the pleasure principle. *SE*, 18: 7–64.

#### Bibliography

Ferenczi, Sándor. (1913). Le développement du sens de la réalité et ses stades. *Oeuvres complètes. Psychanalyse* (Vol. 2, pp. 51–64; J. Dupont, M. Viliker, Trans.). Paris: Payot, 1970.

Jones, Ernest. (1953–57). *Sigmund Freud: Life and work*. London: Hogarth Press.

Laplanche, Jean. (1970). *Vie m en psychanalyse*. Paris: Flammarion.

Porte, Michèle. (1994). *La dynamique qualitative en psychanalyse*. Paris: Presses Universitaires de France.

### BIBLIOTECA NUEVA DE MADRID (FREUD, S., *OBRA COMPLETAS*)

The Biblioteca Nueva de Madrid was the first publishing house to print a Spanish language edition of the "complete works" of Sigmund Freud; it was referred to as such even though it has never been finished. Nearly

contemporary with the German publication of the *Gesammelte Schriften* (1924–1934), the Spanish edition was the first complete translation of Freud's work abroad. Freud himself was surprised that a Madrid editor, José Ruiz-Castillo, would want to publish his work in Spanish. At this time the Spanish population was small and the cultural level relatively undeveloped. In fact the initiative for the project was taken by a well-known Spanish intellectual, José Ortega y Gasset, who had introduced German scientific and philosophic ideas to the Spanish public through the review *Revista de Occidente*. At his suggestion the publication rights were purchased in 1917, but Europe was then at war; all correspondence for the project and the initial proofs had to be sent by diplomatic courier. The first volume, with a preface by Ortega y Gasset, appeared in 1922, and seventeen additional volumes were published by 1934. If we are to believe the letter sent by Freud to his translator, Luis López-Ballesteros y de Torres, on May 7, 1923, he was very agreeably surprised by this version.

Its characteristics need to be considered in relation to its function within the Spanish historical context, which was then in the throes of a cultural and literary renewal. This explains why López-Ballesteros's translation was written in elegant Castilian and was highly literary, which significantly enlarged its readership. However, the translation, although it allowed Spanish readers to familiarize themselves with Freud's thought, lacks any sense of consistency. The primary reason is the absence of any systematic conceptual approach, made worse by the repeated literary and moralizing interjections of the translator, who exercised a certain degree of liberty in his work. There were also a number of omissions of words and sometimes of entire sentences, which considerably altered the original meaning.

JOSÉ GUTIÉRREZ TERRAZAS

*See also:* Spain.

#### Bibliography

García de la Hoz, Antonio. (1985). Freud en castellano. *Libros*, 36, 3–9.

Lázaro, J. (1991). *Las Traducciones al español de Freud: Historia y crítica, actas del IX congreso de historia de la medicina*. Saragossa: Prensas Universitarias y Ayuntamiento de Saragossa.

Ruiz-Castillo Basala, José. (1972). *El Apasionante mundo del libro. Memorias de un editor*. Madrid: Ediciones de la Revista de Occidente.

Vezzetti, Hugo. (1911). Freud en langue espagnole. *Revue internationale d'histoire de la psychanalyse*, 4, 189–207.

Villarreal, Inga. (1992). Spanish Translations of Freud. *Translating Freud*. New Haven/London: Yale University Press.

---

## BIBRING, EDWARD (1894–1959)

A Jewish doctor and psychoanalyst, Edward Bibring was born April 20, 1894, in Stanislau, in Galicia, and died in Boston on January 11, 1959. He obtained the equivalent of his B.A. in Czernowitz and went on to study history and philosophy. After his military service during the First World War, during which he was a prisoner in Russia, he studied medicine in Vienna. His interest in psychoanalysis was stirred by the Vienna Seminar on Sexology, created in 1919 by Otto Fenichel for medical students. It was here that Bibring met his future wife, Grete Lehner.

In 1922, Bibring obtained his diploma in medicine at the University of Vienna and the same year was accepted for training by the Vienna Psychoanalytic Society. He underwent analysis with Paul Federn, and in 1925 became an associate member and in 1927 a full member of the society. He served in a number of positions: treasurer from 1928 to 1938, successor to Paul Schilder as head of the psychosis section in 1929 at the psychoanalytic clinic, and replaced Eduard Hitschmann as director of the clinic in 1932. After 1934, Bibring was a teaching analyst and supervisor in Vienna, secretary of the education committee for the Vienna Psychoanalytic Society, and a co-editor of the *Internationale Zeitschrift für Psychoanalyse*.

In May 1938, following the Anschluss and the rise of National Socialism in Austria, Bibring and his wife Grete emigrated to Great Britain. There he became a member and teaching analyst of the British Psycho-Analytical Society and was one of the editors of the *Gesammelte Werke Sigmund Freuds*. In February 1941, following an invitation from Tufts Medical College to teach, he and his wife left for Boston. He became a member and training analyst of the Boston Psychoanalytic Society and was its President from 1947 to 1949. He practiced psychiatry at Beth Israel Hospital.

In his memoirs, Richard Sterba wrote of Bibring that “He had difficulties expressing himself in writing.

His obsessive character pushed him to undertake such exhaustive research in the literature that it blocked his own analytic output . . . that is why his literary legacy is so limited compared to his knowledge and the richness of his thought” (Sterba, R., 1982).

ELKE MÜHLEITNER

*See also:* Altruism; Lehrinstitut der Wiener psychoanalytischen Vereinigung; Therapeutic alliance; Working-off mechanisms; Wiener psychoanalytischen Vereinigung.

## Bibliography

Bibring, Edward. (1936). Zur entwicklung und problematik der triebtheorie. *Imago*, 22, 147–176.

———. (1950). Considerations in the establishment of training facilities. *Bulletin of the American Psychoanalytical Association*, 6, 36–40.

———. (1954). Psychoanalysis and dynamic psychotherapies. *Journal of the American Psychoanalytical Association*, 2, 745–770.

Mühlleitner, E. (1992). *Biographisches lexikon der psychoanalyse (die mitglieder der psychologischen Mittwoch-Gesellschaft und der Wiener psychoanalytischen Vereinigung 1902–1938)*. Tübingen: Diskord.

Sterba, R. (1982). *Reminiscences of a Viennese psychoanalyst*. Detroit: Wayne State University Press.

---

## BIBRING-LEHNER, GRETE (1899–1977)

A doctor and psychoanalyst, Grete Bibring-Lehner was born in Vienna on January 11, 1899, and died August 10, 1977, in Cambridge, Massachusetts. She was the daughter of Viennese Jewish parents, business people and members of the Jewish intellectual bourgeoisie. She attended a girls' school where she studied the humanities, including psychology, which led to her discovery of Freud. She began her studies at the department of medicine of the University of Vienna in 1918 and participated in the 1919 working group formed by Otto Fenichel to study sexuality and psychoanalysis, the Vienna Seminar on Sexology. Among the students in this seminar were several future analysts, including Wilhelm Reich and Edward Bibring, whom she married in 1921.

Through her participation in the seminar, Bibring-Lehner was able to attend meetings of the Vienna Psychoanalytic Society. Upon completing her medical

studies in 1924, she went on to specialize in neurology and psychiatry. She became a member of the Vienna Psychoanalytic Society in 1925. She completed her personal analysis with Hermann Nunberg while she was finishing her medical studies. She was one of the first students of the Vienna Training Institute, founded in 1925. Bibring-Lehner worked at the psychoanalytic clinic, gave presentations on the technique of therapy, and, after 1934, was a member of the education committee of the Vienna Association. Her first work on psychoanalysis, “The Phallic Phase and its Disturbances in Young Girls,” was published in 1933 in the *Zeitschrift für psychoanalytische Pädagogik*.

After the Germans entered Austria, she migrated with her family in May 1938 to Great Britain and became a member of the British Psycho-Analytical Society. In 1941 the family left for the United States, where Bibring-Lehner became a member and training analyst with the Boston Psychoanalytic Society. She taught psychoanalytic psychology at Simmons College School of Social Work in Boston. In 1946 she joined the administrative staff of the psychiatric division of Beth Israel Hospital. She was named professor of psychiatry at Harvard Medical School in 1961.

She received a number of professional and academic distinctions. In 1955 she was elected president of the Boston Psychoanalytic Society. From 1959 to 1963 she was vice president of the International Psychoanalytic Association and, in 1962, became president. In 1968 *The Teaching of Dynamic Psychiatry* was published, of which she was the general editor. Her research on pregnancy and mother-child relationships provided an important contribution to women’s psychology.

ELKE MÜHLEITNER

*See also:* Lehrinstitut der Wiener psychoanalytischen Vereinigung; Parenthood; Wiener psychoanalytischen Vereinigung.

### **Bibliography**

Bibring-Lehner, Grete. (1933). “Über die phallische Phase und ihre Störungen beim Mädchen.” *Zeitschrift für psychoanalytische Pädagogik*, 7, 145–152.

———. (1968) “Teaching of dynamic psychiatry. A reappraisal of the goals and techniques.” In *The teaching of psychoanalytic psychiatry*. New York: International University Press.

Mühlleitner, Elke. (1992). *Biographisches lexikon der psychoanalyse (die mitglieder der psychologischen Mittwoch-Gesellschaft und der Wiener psychoanalytischen Vereinigung 1902–1938)*. Tübingen: Diskord.

Sterba, Richard. (1982). *Reminiscences of a Viennese psychoanalyst*. Detroit: Wayne University Press.

---

## **BICK, ESTHER (1901–1983)**

Esther Bick, a physician and psychoanalyst, was born of orthodox Jewish parents in 1901 near Kraków, Poland, and died on July 20, 1983, in London. Her maiden name remains unknown. Her friends referred to her as Nusia. Unable to study medicine in Poland because of the many restrictions on Jews, she moved to Vienna, where she worked with Charlotte Buhler on the experimental observation of young twins. It was during this period of her training that the foundations were established for her later work in psychoanalysis. Having refined a methodology for the objective observation of infants (time studies, quantitative descriptive analysis), she continued to formalize a new method of observation that was able to take into account the subjective and emotional environment of the child, together with the experience of the observer.

Her marriage is difficult to date precisely and appears to have been short-lived. Following Germany’s annexation of Austria on March 12, 1938, Esther Bick reached London, where she became a student of Melanie Klein. Martha Harris indicates in the obituary she wrote for Bick’s death that her brother and the rest of her family died in concentration camps and that only one of her nieces escaped the holocaust. This niece later moved to Israel, although Bick did not learn of this until the 1950s.

During the Second World War, Bick worked in a nursery in Manchester, where she began an analysis with Michael Balint. She completed her analytic studies in London, while working at a child guidance clinic in Middlesex with Portia Holman. In 1949 she joined the Tavistock Clinic, where John Bowlby asked her to provide a training course for future analysts. There she developed her method of infant observation, which encouraged observers to watch and listen to infants during their early development and focused on in-depth analysis of the capacity for attention and psychic transformation. It was also during this period that she began a second analysis with Melanie Klein.

Esther Bick wrote little, but what she did write was influential and is intentionally situated within what has customarily been referred to as the post-Kleinian movement. She noted the importance of the skin during infant relations (this opened the way to an entire field of research on the establishment of psychic envelopes and, in France, to the work of Didier Anzieu on the skin ego). She was also interested in the observation of infants from a psychoanalytic perspective. Bick's methodology for infant observation has been integrated into the training of child analysts, and even of some adult analysts, in several countries (Great Britain, Belgium, Italy). In France, the issue is more controversial, especially regarding the status of observed material compared with conventional analytic material. Some applications of her method have been developed not only for training but also for therapeutic purposes.

In any case, the rigor of Bick's methodology, together with her sense of ethical conduct, have had a profound influence on child psychologists since the 1970s. Her work has drawn their attention (along with that of some adult psychologists as well) to the more archaic levels of functioning and the earliest stages of mental development in the infant. In France, Bick's ideas have been taken up by authors like Geneviève Haag and Didier Houzel, who trained with Bick.

Bick's two great passions throughout her life were psychoanalysis and Israel, and she placed her hopes in both of them. Bick ceased clinical practice in 1980.

BERNARD GOLSE

*See also:* Adhesive identification; Body image; Infantile psychosis; Infant observation; Infant observation (therapeutic); Object; Psychic envelope; Skin.

### **Bibliography**

Bick, Esther. (1964). Notes on infant observation in psychoanalytic training. *International Journal of Psycho-Analysis*, 45, 558–566.

———. (1968). The experience of the skin in early object relations. *International Journal of Psycho-Analysis*, 49, 558–566.

Haag, Michel, and Haag, Geneviève. (1995). L'observation des nourrissons selon Esther Bick (1901–1983) et ses applications. *Information psychiatrique*, 1, 7–17.

Harris, Martha. (1983). Esther Bick, 1901–1983. *Journal of Child Psychotherapy*, 9, 101–102.

Harris, Martha, and Bick, Esther. (1987). *Collected papers of Martha Harris and Esther Bick*. Perthshire, U.K.: Clunie Press for Roland Harris Education Trust.

---

## **BIGRAS, JULIEN JOSEPH NORMAND (1932–1989)**

A Canadian psychiatrist and training analyst, Julien Bigras was born February 12, 1932, in Laval, Quebec, and died May 10, 1989, in Montreal. He spent his childhood at the family farm and studied medicine and psychiatry at the University of Montreal; he completed his psychoanalytic training at the Paris Psychoanalytic Institute.

A member of the Paris Psychoanalytic Society (1963) and the Canadian Psychoanalytic Society (1954), and a training analyst, he maintained a psychoanalytic practice, directed a seminar, published the review *Interprétation* (Montreal) and two collections of books in Paris and Montreal, and collaborated on *Études Freudiennes* (Denoël, Paris) and *Patio* (Paris). He also ran a seminar at McGill University (1983–1989) and participated in the Clinical Lacanian Forum in the United States.

He published ninety-one articles, twenty-six chapters in anthologies, and eleven works of fiction including *L'Enfant dans le grenier* (1977), *Le Psychanalyste nu* (1979), *Kati of course* (1980), *Ma Vie, ma folie* (1983), and *La Folie en face* (1986).

He was a great admirer of Donald Woods Winnicott, Harold Searles, and Sándor Ferenczi because of their lack of dogmatism and their clinical freedom of expression during transference. Madness, incest, the therapeutic use of stories, and transference and violence associated with the psychoanalyst were common themes throughout his work. Bigras's research led him to ask two fundamental questions: 1) Is violence necessary for access to the unconscious, does it provide the only opportunity for the analysand and for the psychoanalyst/analysand to rediscover or recreate a new and singular maternal language, a primal language, the only one that can produce the fecundity of being? 2) Is the violence of the psychoanalyst (the unanalyzed in all of us) an expression of the other's desperate cry to be heard, a limiting transference situation in which the

one who is best able to hear this cry would be his own patient? Can writing or any other form of creative art provide confirmation, and pick up the thread where the analysand or the analyst left off?

ÉLISABETH BIGRAS

*See also:* Canada; *Études Freudiennes; Interprétation; Société psychanalytique de Montréal (Psychoanalytic Society of Montreal).*

### **Bibliography**

- Bigras, Julien. (1977). *L'enfant dans le grenier*. Paris: Hachette.
- . (1979). *La folie en face*. Paris: Robert Laffont.
- . (1979). *Le psychanalyste nu*. Paris: Robert Laffont.
- . (1980). *Kati of course*. Paris: Mazarine.
- . (1983). *Ma vie, ma folie*. Paris-Montréal: Mazarine-Boréal Express.

## **BINDING/UNBINDING OF THE INSTINCTS**

Binding is the mechanism whereby the free-flowing energy of the primary processes becomes attached to ideas, thus giving instinct a representative within the psychic agencies. In this way, instinctual excitation seeking an object is gradually tamed by the ego, and ideas are linked to one another and then maintained in a relatively stable state. This mode of functioning, characteristic of the secondary processes, enables the work of thinking to take place. Unbinding, on the other hand, is the abrupt retransformation of bound energy into free energy seeking discharge. Binding and unbinding are thus two essential economic aspects of the work of the psyche.

Freud first used the notion of binding in October 1895, in “Project for a Scientific Psychology” (1950c), proposing “the hypothesis of what is, as it were, a *bound state* in the neurone, *which, though there is a high cathexis, permits only a small current,*” and asserting that “the ego itself is a mass like this of neurones which hold fast to their cathexis—are, that is, in a bound state” (p. 368). At this time, on his way to discovering the unconscious, Freud was seeking to understand the surging up of elements that did not belong to the ego’s thought processes: “If a passage of thought comes up against a still *untamed mnemic* image of this

kind, then its indications of quality, often of a sensory kind, are generated, with a feeling of unpleasure and an inclination to discharge, the combination of which characterizes a particular affect, and the passage of thought is interrupted... What is it, then, that happens to *memories* capable of affect till they are *tamed*? ... Particularly large and repeated binding from the ego is required before this facilitation to unpleasure can be counterbalanced” (pp. 380–381).

At the dawn of psychoanalysis, Freud was seeking to explain how the energy of the primary process could be held in check and yet at the same time continue to procure pleasure and be used in the construction of the ego. In “Project for a Scientific Psychology,” the notion of binding was given its full place, since it helps establish a level of relative constancy in the ego. By contrast, instinctual excitation, when it is too strong, threatens the ego with unbinding.

Freud made a brief comment in “Formulations on the Two Principles of Mental Functioning” (1911b): “Thinking was endowed with characteristics which made it possible for the mental apparatus to tolerate an increase of stimulus while the process of discharge was postponed. It is essentially an experimental kind of acting, accompanied by displacement of relatively small quantities of cathexis together with less expenditure (discharge) of them” (p. 221). Later in “Instincts and Their Vicissitudes” (1915c), Freud emphasized, “A particularly close attachment of the instinct to its object is distinguished by the term ‘fixation’” (p. 123). In “The Unconscious” (1915e) he emphasized the opposition between “two different states of cathectic energy in mental life: one in which the energy is tonically ‘bound’ and the other in which it is freely mobile and presses towards discharge” (p. 188).

In *Beyond the Pleasure Principle* (1920g), in revamping his earlier instinctual dualism, Freud took traumatic neurosis as one of several bases for the new opposition between the life and death instincts. In this context, “it would be the task of the higher strata of the mental apparatus to bind the instinctual excitation reaching the primary process. A failure to effect this binding would provoke a disturbance analogous to a traumatic neurosis; and only after the binding has been accomplished would it be possible for the dominance of the pleasure principle (and of its modification, the reality principle) to proceed unhindered” (pp. 34–35).

In his paper “Negation” (1925h), Freud added a new element: “The general wish to negate, the negativism which is displayed by some psychotics, is probably to be regarded as a sign of a defusion of instincts that has taken place through a withdrawal of libidinal components” (p. 239).

Finally, in *An Outline of Psycho-Analysis* (1940a [1938]), Freud condensed his ideas by making binding and unbinding the two essential features of his theory of the instincts: “[We] have decided to assume the existence of only two basic instincts, *Eros* and *the destructive instinct*. . . . The aim of the first of these basic instincts is to establish ever greater unities and to preserve them thus—in short, to bind together; the aim of the second is, on the contrary, to undo connections and so to destroy things” (p. 148).

Although the fundamental idea of binding and unbinding underwent gradual clarification as Freud’s research advanced, it gained a new coherence with his last theory of the instincts. In particular, it now shed light on fixation as a response to excess binding after an unbinding that flooded the psychic apparatus. One problem remained unsolved, however, namely the differences, in economic terms, between unbinding and failure of binding. Unbinding resulted from an active process that Freud plainly related to Thanatos (the death instinct), whereas the failure of binding seemed to be more passive, perhaps a result of a limit on available libidinal energy.

Lastly, free association seems to be based on more or less effective instances of the binding and unbinding of ideas among themselves and of ideas and effects. Such binding and unbinding in turn determine the nature of the transference.

PIERRE DELION

*See also:* Fusion/defusion.

### **Bibliography**

- Freud, Sigmund. (1911b). Formulations on the two principles of mental functioning. *SE*, 12: 213–226.
- . (1915c). Instincts and their vicissitudes. *SE*, 14: 109–140.
- . (1915e). The unconscious. *SE*, 14: 159–204.
- . (1920g). Beyond the pleasure principle. *SE*, 18: 1–64.
- . (1925h). Negation. *SE*, 19: 235–239.

———. (1940a [1938]). An outline of psycho-analyses. *SE*, 23: 144–207.

———. (1950c [1895]). Project for a scientific psychology. *SE*, 1: 281–387.

### **BINSWANGER, LUDWIG (1881–1966)**

Ludwig Binswanger, a Swiss psychiatrist, was born on April 5, 1881, in Kreuzlingen, Thurgau, Switzerland, where he died on February 7, 1966. In Kreuzlingen he was director of clinical psychiatry at Bellevue Sanatorium, an internationally renowned institution founded by his grandfather. Binswanger took over responsibilities in 1910 from his father, passing them on to his own son in 1956.

He spent his school years in Constance, Germany, and studied medicine in Lausanne, Heidelberg, and Zurich. In 1906 he obtained the position of assistant at the Burghölzli Psychiatric Clinic in Zurich, directed by Eugen Bleuler. In 1907 he defended his doctoral dissertation on association tests before Carl Gustav Jung.

Binswanger devoted his life to psychiatry and the search for new therapeutic treatments. His father had introduced a revolutionary method for running the clinic, according to which the “doctor’s family will also assist in treating the patient.” The entire institution became, in effect, an extended family presided over by a patriarch. Ludwig Binswanger was raised in a world where “the father’s teachings were the absolute law.” He developed an interest in psychoanalysis at the Burghölzli Clinic, where the medical staff included some of the leading psychoanalysts of the time (Karl Abraham, Max Eitingon, Franz Riklin, and Hermann Nunberg). Jung was the director. In 1907 he met with Freud (“his most important human experience”) in the company of Jung. This led to other meetings and a thirty-year friendship, as shown by their lengthy correspondence. Although Freud had difficulties, recognized by Freud himself, in maintaining friendships with people who did not share his ideas, and although they had different attitudes toward fundamental aspects of psychoanalysis and its potential uses, they enjoyed an extended friendship. This friendship was based on an understanding of mutual expectations: Freud hoped to break down the wall separating official psychiatry and psychoanalysis, and Binswanger sought

to fight for the acceptance of a new theory under Freud's paternal control.

Binswanger wrote nearly a hundred articles and books. He wrote reports of analyses ("Versuch einer Hysterie Analyse," 1909; "Analyse einer Hysterischen Phobie," 1911) and methodological criticisms of psychoanalysis like *Die drei Grundelemente des wissenschaftlichen Denkens bei Freud* (The three fundamental elements of Freud's scientific ideas; 1921). In *Grundformen und Erkenntnis menschlichen Daseins* (Fundamental forms and the recognition of human being-in-the-world; 1953), Binswanger attempted to define existential analysis as an empirical science involving an anthropological approach to the individual essence of being human.

Over the years Binswanger's contributions to psychoanalysis were marked by an increasing reserve, as shown in his introduction of psychoanalytic therapy as an element of institutional care. In 1907 his uncle, Otto Binswanger, a professor of psychiatry in Jena, presented him with a hysterical patient, Irma, for analysis, which he undertook on the basis of his reading alone. He treated a number of other patients who required institutional care, including some of Freud's patients. His beginner's enthusiasm was soon subject to setbacks as a result of his lack of rigor. He concluded, "Ten years of effort and disappointment have been the price to pay to be able to recognize that only a select number of our institutional patients can benefit from analysis."

Binswanger began to subject psychoanalysis to a methodological and critical analysis. He began by attacking the methodology of general psychology and then attempted an epistemological criticism of psychoanalysis itself. He made use of Edmund Husserl's phenomenology and the hermeneutics of Wilhelm Dilthey and Friedrich Schleiermacher. For him, the link between Freud's scientific method and clinical psychiatry is a shared reduction of human existence to a schema or system. In his new approach, human existence is necessarily human, and the task for existential analysis is to describe the fundamental orientations of that existence.

After Martin Heidegger's *Being and Time*, Binswanger underwent a second transition from phenomenology to phenomenological ontology and switched from a methodological approach to an anthropological approach. For Heidegger, *Daseinanalytik* (existential

analysis of being in the world) consists in describing the structure of human existence as such. Binswanger's *Daseinanalyse* attempted to contrast the natural sciences, which treat the human being as a "system of organic functions," with a phenomenological methodology that attempted to explore humanity's subjective existence in its totality and that looked at the individual as a being present in the world, a being responsible for its own existence from within. To help the patient, the therapist engages with the patient's primal world and how the patient is present in the world. Mental illnesses are "modifications of the fundamental structure and structural bonds of the being-in-the-world as transcendence." Therapy does not consist in "an attempt, starting with the ego, to enable the organism to connect with another through language, but makes language itself its starting point."

*Daseinanalyse*, as practiced by Binswanger, Medard Boss, Henri F. Ellenberger, and Rollo May, maintained a distance from the theory and practice of Freudians. Freud himself acknowledged, "We are unable to establish a dialogue between us."

RUTH MENAHEM

*See also:* Hirschfeld, Elfriede; Phenomenology and psychoanalysis; Psychoanalytic epistemology; Schizophrenia; Switzerland (German-speaking).

### Bibliography

- Binswanger, Ludwig. (1920). Psycho-analysis and clinical psychiatry. *International Journal of Psycho-Analysis*, 1 (3), 357.
- . (1953). *Grundformen und Erkenntnis menschlichen Daseins* (2nd ed.). Zurich, Switzerland: Niehans.
- . (1957). *Sigmund Freud: Reminiscences of a friendship* (Norbert Guterman, Trans.). New York: Grune & Stratton. (Original work published 1955)
- . (1971). *Introduction à l'analyse existentielle* (Jacqueline Verdeaux and Roland Kuhn, Trans.). Paris: Minuit.
- Fédida, Pierre. (1986). Le contre-transfert en question. *Psychoanalyse à l'Université*, 11 (41), 19–30.
- Freud, Sigmund, and Binswanger, Ludwig. (1992 [1908–1938]). *The Freud-Binswanger Correspondence, 1908–1938* (Arnold J. Pomerans, Trans.). New York: Other Press, 2003.



Lantéri-Laura, Georges. (1963). *La psychiatrie phénoménologique: Fondements philosophiques*. Paris: Presses Universitaires de France.

## BIOLOGICAL BEDROCK

In the last paragraph of “Analysis Terminable and Interminable” (1937c), Freud wrote: “We often have the impression that with the wish for a penis and the masculine protest we have penetrated through all the psychological strata and have reached bedrock [*gewachsener Fels*: “the living rock”], and that thus our activities are at an end. This is probably true, since, for the psychical field, the biological field does in fact play the part of the underlying bedrock” (p. 252).

As a limit imposed upon psychoanalytical treatment, which is brought to a halt by its inaccessibility to psychic working over, the biological level played a complicated and ever-present motor role in Freud’s work. By 1894 he had already introduced three important notions related to this frontier: *libido*, or psychical sexual energy transmuted from somatic energy; *conversion*, or the hysterical mechanism of transformation of psychic libidinal energy into somatic innervation; and the *sexual instinct*, the earliest attempt to conceptualize such “phase shifts”—whether continuous or sporadic—between the body and the mind.

In *Three Essays on the Theory of Sexuality* (1905d), what Freud called “that part of the theory . . . which lies on the frontier of biology” (p. 133)—the theory of the instincts—created the dynamic frame of reference in which psychic morphogenesis could be grafted onto the underlying biology of onto- and phylogenesis. And in his preface to the third edition (1914) of the *Three Essays*, Freud added: “I must, however, emphasize that the present work is characterized not only by being completely based upon psycho-analytic research, but also by being deliberately independent of the findings of biology. . . . Indeed, my aim has rather been to discover how far psychological investigation can throw light upon the biology of the sexual life of man. . . . there was no need for me to be diverted from my course if the psycho-analytic method led in a number of important respects to opinions and findings which differed largely from those based on biological considerations” (p. 131). Both the interdependence and the relative autonomy between the mental and the biological were thus affirmed.

In fact Freud drew attention to infantile sexual activity before its organic correlates were discovered—the word *hormone* came into use in 1905. He specified the two developmental biological traits responsible for the singular ubiquity of sexuality in human mental life, namely prematurity and the latency period. Freud inferred that humans were descended from a species that reached sexual maturity at the age of about five; this conclusion, which is confirmed by current paleo-anthropology, relates the Oedipus complex to the “bedrock” of the biological development of the species.

Another point of contact between the mental and the biological lay in mnemonic phenomena, in memory traces and their transmission. As Freud wrote in *The Interpretation of Dreams* (1900a), “Dreams and neuroses seem to have preserved more mental antiquities than we could have imagined possible; so that psychoanalysis may claim a high place among the sciences which are concerned with the reconstruction of the earliest and most obscure periods of the beginnings of the human race” (p. 549). The life and death instincts, another interface with the “bedrock,” were the basis of a hypothetical biology centered on the diversity of the stabilizing mechanisms of living beings—on their ability to internalize external factors and to regularize and convey them on the biological and the mental levels simultaneously. In short, Freud was proposing a kind of Lamarckianism revisited whose necessity would one day be acknowledged by official science: “For incalculable ages mankind has been passing through a process of evolution of culture,” he wrote to Albert Einstein, which “is undoubtedly accompanied by physical alterations; but we are still unfamiliar with the notion that the evolution of civilization is an organic process of this kind” (1933b [1932], p. 214).

Penis envy and castration fears were paradigmatic of the complicated, intrinsic causal relationship between the mental and the biological. The unique narcissism of human beings, along with the ideal individual and collective forms to which it gave rise, was likewise, by virtue of prematurity, closely bound up with biology.

The transition between soma and psyche lies at the core of Freud’s work. His theory of the instincts is the conceptual instrument that makes it possible to examine this zone without falling prey to neurophysiological reductionism or to the dichotomies of idealism.

This set of problems has often been avoided since Freud. It may not be strictly necessary to confront it as a practical matter in treating neuroses, but it is surely essential to do so if we wish fully to understand the dynamics of mental functioning. There are many ways, however, to evade the issue, and to maintain the ancient split between soma and psyche: neglecting or rejecting the theory of the instincts (like the British school); confining that theory to an exclusively clinical realm (Melanie Klein), or to an exclusively structural one that ignores the economic dimension (Jacques Lacan); or suppressing Freud's biological work on fantasies (Gantheret). The diametrically opposite approach, a neopositivist reading of Freud's work as a "biogenetic fable" (Sulloway), has the same result. On the other hand, some biologists with a more nuanced epistemology (Jean-Didier Vincent, Alain Prochiantz) have been reassessing the dynamic point of view in their discipline in a way that restores its relevance to the Freudian position, which a certain number of psychoanalysts (such as those concerned with the earliest mother-child bonds and with psychosomatic illnesses) have never abandoned.

MICHÈLE PORTE

*See also:* "Analysis Terminable and Interminable"; Castration complex; Femininity; Penis envy; Phylogenesis; Real trauma; Termination of treatment.

### **Bibliography**

- Freud, Sigmund. (1900a). The interpretation of dreams. *SE*, 4–5.
- . (1905d). Three essays on the theory of sexuality. *SE*, 7: 123–243.
- . (1933b [1932]). Why War? (Einstein and Freud). *SE*, 22: 195–215.
- . (1937c). Analysis terminable and interminable. *SE*, 23: 209–253.
- Gantheret, François. (1975). Quelques éléments de recherche sur la place du biologique dans la théorie psychanalytique. *Psychanalyse à l'Université*, 1 (December 1), 97–104.
- Sulloway, Frank J. (1979). *Freud, biologist of the mind*. New York: Basic.

### **Further Reading**

- Silverstein, Barry. (1985). Freud's psychology and its organic foundation: Sexuality and mind-body interactionism. *Psychoanalytic Review*, 72, 199–228; 203–228.

## **BION, WILFRED RUPRECHT (1897–1979)**

Wilfred Ruprecht Bion was born at Mattra (United Provinces, India) on September 8, 1897, and died in Oxford (Great Britain) on November 8, 1979.

The first eight years of Bion's life were spent in India, where his father was a civil engineer. In 1905 Bion was sent to school in England, where he remained for ten years before taking up military service. While he read history at Queen's College, Oxford, (1919–1921) he became curious about Freud's writings and later furthered his interest in psychology by reading medicine at University College Hospital, London (1924–1930), where he won the Gold Medal for Surgery and the Silver Medal for Diagnostics. He entered analysis with John Rickman in 1938, being forced to terminate by the outbreak of World War II. During the war, as a military psychiatrist, he initiated a new approach to group therapy. He entered analysis with Melanie Klein in 1945, and qualified as an associate member of the British Psychoanalytical Society in 1950.

Bion came from a Protestant missionary family, Swiss Calvinist of Huguenot origin on his father's side and Anglo-Indian on his mother's. This religious background, combined with the fact that the family was isolated from other Europeans for extended periods, meant that the small boy was in close contact with two very different cultures. Experiences of contrast and opposition, but also of mediation and love between two worlds formed a background to, and a basis for, Bion's later theories regarding what it may mean for an individual to be both a member of his group and in contrast or opposition to it at the same time.

This experience was reinforced by the carnage of World War I: he joined the Royal Tank Regiment (1916–1918) where he was awarded the Distinguished Service Order, the Legion d'Honneur (chevalier) and was mentioned in dispatches. Although distant from psychoanalysis, these experiences nurtured his understanding of terror, awe, dependence, love, hatred, and hatred of understanding and knowledge; this latter helped in his deep contact with psychotic patients.

He held several appointments in public positions: Secretary (1933–1939) and then Chairman (1946) of the Medical Section of the British Psychological Society (BPS); Chairman of the Executive Committee, Tavistock Clinic, London (1945); Director of the London

Clinic of Psychoanalysis (1956–1962) and President of the British Psychoanalytical Society (1962–1965). He continued as an active member of the Executive of the BPS, and as Chairman of The Melanie Klein Trust, until he left for California in January 1968. He taught a great deal in Latin America during the last decade of his life before his return to England in 1979 a few months before his death. In 1978 he became an honorary member of the Los Angeles Psychoanalytic Society and in 1979 an Honorary Fellow of the A. K. Rice Institute.

Bion's main contributions to psychoanalysis belong to the fields of psychoanalytical technique and epistemology, with particular reference to the process of thinking. He approached this latter subject from different viewpoints (vertices): that of the group; of the psychotic, schizophrenic or borderline patient; and that of the individual thinker, "genius" or not, who has to deal with the pressure of attacks, from within and without, due to hostility towards both the thinking process and the resulting thoughts. The principal concepts he developed are those of "reverie based on free-floating attention", "alpha-function," which Bion himself felt could replace the Freudian theory of primary and secondary processes, *alpha-* and *beta-elements*, container and contained, and "reversed perspective." His writing is commonly considered challenging, particularly the trilogy *A Memoir of the Future* (1975, 1977, 1979/1991). His other most important publications are *Experiences in Groups* (1961), *Four Servants* (1977) and *Attention and Interpretation* (1970).

Bion's influence in the field of group psychotherapy and the development of more or less closely related group techniques was both very rapid and widespread. In the field of psychoanalysis, despite the fact that his thinking is firmly rooted in that of Freud and Klein, his innovative ideas and theories engendered a great deal of controversy, and were hardly accepted until the 1970s.

PARTHENOPE BION TALAMO

*Work discussed: Learning from Experience.*

*Notions developed:* Alpha function; Arrogance; Attention; Basic assumption; Beta-elements; Beta-screen; Bizarre object; Catastrophic change; Concept; Contact-barrier; Container-Contained; Dream-like memory; Grid; Group phenomenon; Hallucinosi; Invariant; Linking, attacks on; Love-Hate-Knowledge (L/H/K links); Maternal reverie, capacity for; Memoirs of the future; Negative capa-

city; Preconception; Protothoughts; Psychotic panic; Psychotic part of the personality; Realization; Relations (commensalism, symbiosis, parasitism); Selected fact; Thought-thinking apparatus; Transformations; Vertex.

*See also:* Autobiography; Birth; Emotion; Fusion/defusion; Great Britain; Group analysis; Group psychotherapies; Infant development; Internal object; Infans; Negative, work of the; Non-verbal communication; Primary object; Primal, the; Protective shield; Reverie; Second World War: The effect on the development of psychoanalysis; Self-analysis; Splitting; Symbolic equation; Tavistock Clinic.

### **Bibliography**

- Bion, Wilfred R. (1961). *Experiences in groups*. London: Tavistock Publications.
- . (1962). *Learning from experience*. London: Heinemann; New York: Basic Books.
- . (1963). *Elements of psycho-analysis*. London: Heinemann.
- . (1965). *Transformations: Change from learning to growth*. London: Heinemann.
- . (1967). *Second thoughts*. London: Heinemann.
- . (1970). *Attention and interpretation*. London: Tavistock Publications.
- . (1991). *A memoir of the future, Vol. I, the dream*. London: Karnak Books.
- . (1991). *A memoir of the future, Vol. II, The past presented*. London: Karnak Books.
- . (1991). *A memoir of the future, Vol. III, The dawn of oblivion*. London: Karnak Books.
- Grinberg, León, Sor, Dario, Tabak de Bianchedi, Elizabeth. (1977). *Introduction to the work of Bion: Groups, knowledge, psychosis, thought, transformations, psychoanalytic practice*. (Alberto Hahn, Trans.). New York: Jason Aronson.
- . (1993). *New introduction to the work of Bion*. Northvale, NJ; London: Jason Aronson.
- Grotstein, James S. (1981). *Do I dare disturb the universe?*. Beverly Hills, CA: Caesura Press.
- Pines, Malcolm, (Ed.). (1985). *Bion and group psychotherapy*. London: Routledge.

---

## **BIPOLAR SELF**

The bipolar self is made up of two components: the grandiose self, that of mirroring or ambitions; and the idealized parental imago, that of both idealization and ideals. The two poles are linked together by a tension

arc, the alter ego. First appearing in Heinz Kohut's *The Restoration of the Self* (1977), the bipolar self was the hallmark of a new metapsychology: generalized self psychology.

The two constituent poles of the self are formed in response to the degree of the receptivity of caregivers to the subject's narcissistic needs. The grandiose self acquires its strength through the responses of the self objects to mirroring needs, and the idealized parental imago by means of responses that enable fusion. Together both sectors are a source of strength to the self. Each pole is a possibility, a potential for the self. One pole can compensate for the other, and the self will be fragile only if both poles have been thwarted.

When its earliest needs have not been responded to, the infant turns to a less rejecting source. In such a case, it is this second source that will be activated and worked through in the transference, leaving the earliest traumas in the dark. Anything that has been resolved or surmounted will not be examined in analysis. Developments that are no longer the result of conflict are seen as a natural process if narcissism is taken to be a given.

AGNÈS OPPENHEIMER

*See also:* Grandiose self; Idealized parental imago; Kohut, Heinz; Self psychology.

### **Bibliography**

Kohut, Heinz. (1977). *The restoration of the self*. New York: International Universities Press.

———. (1984). *How does analysis cure?* Chicago: University of Chicago Press.

## **BIRTH**

Birth is the prototype for all discontinuities in the relation between a mind and its objects. Otto Rank's *The Myth of the Birth of the Hero* (1909) introduced this theme into psychoanalytic literature.

In the same year Freud took an interest in dreams of birth in an addendum to *The Interpretation of Dreams* (1900a). Birth, as a passage from intra-uterine life to extra-uterine life became for him "the first experience of anxiety, and thus the source and prototype of the affect of anxiety" (*SE*, 5: 525, note 2). He returns to this theme in *Introductory Lectures on*

*Psychoanalysis* (1916-17a [1915-17]), in which he speaks of the "separation" (*SE*, 15: 397) of birth.

This is the theme that Wilfred Bion developed in *Caesura* (1975) when he made birth the paradigm for all psychic discontinuity, which means that experiences lived through before the caesura must be capable of being retranscribed in a psychically assimilable form after the caesura. Taking a more genetic point of view, other authors have applied the term "psychic birth" to the moment when children become conscious of their individuation and the separation between them and their libidinal objects (Mahler, Margaret, 1975; Tustin, Frances, 1981).

DIDIER HOUZEL

*See also:* Constitution; Dream symbolism; Infant development; Infant observation; Infant observation (therapeutic); Infantile psychosis; Intergenerational; Maternal; Memoirs of the future; *Myth of the Birth of the Hero*, *The*; Narcissistic elation; Parenthood; Postnatal/postpartum depression; Premature-Prematurity; Primary love; Reversal into the opposite; Seduction; Sexual theories of children; Social feeling (individual psychology); *Trauma of Birth*, *The*.

### **Bibliography**

Bion, Wilfred R. (1975). *The grid and Caesura*. Rio de Janeiro: Imago.

Freud, Sigmund. (1900a). The interpretation of dreams. Part I. *SE*, 4, 1-338.

———. (1900a). The interpretation of dreams. Part II. *SE*, 5: 339-625.

———. (1916-17a [1915-17]). Introductory lectures on psycho-analysis. Parts I and II. *SE*, Part I, 15; Part II, 16.

Mahler, Margaret, Pine, Fred, and Bergman, Anni. (1975). *The psychological birth of the human infant*. New York: Basic Books.

Tustin, Frances. (1981). *Autistic states in children*. London: Routledge.

## **BIRTH, DREAM OF**

The dream of birth is a dream that depicts, generally in a transposed way, the birth of the dreamer or, in women, the act of giving birth.

In *The Interpretation of Dreams* (1900), Freud classed this type of dream among the "typical dreams,"

but this classification appeared only with his addenda to later editions. In an addition made in 1909, he wrote: "A large number of dreams, often accompanied by anxiety and having as their content such subjects as passing through narrow spaces or being in water, are based upon phantasies of intra-uterine life, of existence in the womb and the act of birth" (p. 399). He also reported, in a note dating from 1909, Carl G. Jung's opinion that, in women, dreams of having teeth pulled signified childbirth (pp. 387–88, note 3). He cited the dream of a young man "who, in his imagination, had taken advantage of an intra-uterine opportunity of watching his parents copulating" (pp. 399–400). In subsequent addenda he analyzed the dream of a young woman which expressed her fear of (and wish for) the loss of her virginity and the birth of the baby that would result, as well as several other dreams with this meaning reported by Otto Rank and Karl Abraham. In 1919, he added to the 1909 note cited above Ernest Jones's observation that what the pulled tooth and childbirth had in common was the meaning of "separation of a part of the body from the whole" (pp. 387–88, note 3). Accordingly, the dream of birth can be linked to the theme of castration.

As with most of the other "typical dreams," there is hardly any further discussion of this type of dream in Freud's work, and the later literature is limited, despite the fact that such dreams are often encountered in clinical work.

ROGER PERRON

*See also:* Birth; Castration complex; Dream; *Myth of the Birth of the Hero, The.*

### **Bibliography**

Freud, Sigmund. (1900). The interpretation of dreams. *SE*, 4–5: 1–625.

---

## **BISEXUALITY**

The notion of bisexuality—according to which all human beings simultaneously possess both masculine and feminine sexual dispositions—was introduced into psychoanalysis by Freud.

It should be noted that the notion of bisexuality has always existed, as witness its mention in most

religions. The idea of a primeval divine couple that is demonstrated by myths and rituals of human androgyny, is based on the existence of a supreme androgynous divine being from whom the couple are separated (Eliade, 1964).

The idea of bisexuality was already present in philosophical and psychiatric literature at the end of the 1880s, but its importance within the psychoanalytic movement begins with the influence of Wilhelm Fliess. In 1901, convinced of the scope of psychical bisexuality, Freud informed Fliess of a project that unfortunately did not see the light of day: "My next book, as far as I can see, will be called 'Bisexuality in Man'" (1950a, p. 334).

Freud based his theory on anatomical and embryological data: "a certain degree of anatomical hermaphroditism occurs normally. In every normal male or female individual, traces are found of the apparatus of the opposite sex" (1905d, p. 141). This observation resulted in his conception of an "originally bisexual physical disposition [that] has, in the course of evolution, become modified into a unisexual one, leaving behind only a few traces of the sex that has become atrophied." But he did not apply this conception to the psychical domain: "It is impossible to demonstrate so close a connection between the hypothetical psychical hermaphroditism and the established anatomical one" (p. 142).

Freud did not give these biological facts the same scope as did Fliess, who believed that the psychic mechanism of repression has a biological foundation. For Freud, it is not the apparent anatomical sex that represses the opposite sex: "I am only repeating what I said then in disagreeing with [Fliess's] view, when I decline to sexualize repression in this way—that is, to explain it on a biological grounds instead of on purely psychological ones" (1937c, p. 251).

Throughout his career, Freud emphasized the importance of bisexuality in mental phenomena: "[W]ithout taking bisexuality into account I think it would scarcely be possible to arrive at an understanding of the sexual manifestations that are actually to be observed in men and women" (1905d, p. 220). Nor would it be possible to understand the conflicts that result from it: "In order to explain why the outcome is sometimes perversion and sometimes neurosis, I avail myself of the universal bisexuality of human beings" (1950a, p. 179). And it was through the analysis of the

psychoneuroses that Freud found confirmation of the “postulated existence of an innate bisexual disposition in man” (1908a, p. 165–166).

Nevertheless, it is noteworthy that there were some hesitations in his considerations of this question. In 1923, he attributed the difficulty of disentangling the problem of object choice in the first sexual period to “the triangular character of the Oedipus situation and the constitutional bisexuality of each individual” (1923b, p. 31). Thus he suggested that bisexuality is independent of the processes of identification. Next he argued that identification with the father or mother is the result of the oedipal situation and is strictly linked to bisexuality, because the identifications are simultaneously masculine and feminine. However, when he saw the child’s ambivalence toward its parents as deriving from an origin other than identification, he insisted on the weight of innate bisexual dispositions: “It may even be that the ambivalence displayed in the relations to the parents should be attributed entirely to bisexuality” (p. 33). On the one hand, then, the notion of bisexuality makes it possible to explain, in both boys and girls, the oedipal identifications with the parent of the opposite sex, thus feeling the Oedipus complex from any form of determinism. But on the other hand, if bisexuality does not have a biological-anatomical origin, the question of its origin remains obscure: Is it a consequence of anatomy? The result of identifications with both parents? Freud’s answer, especially around the time of *The Ego and the Id*, was that bisexuality was an intrinsic aspect of sexual differentiation itself.

Be that as it may, the concept is constantly invoked and continuously used in day-to-day psychoanalysis. The role played by bisexuality in the different stages of psychosexual development helps to determine the various modalities of the subject’s attachment to objects.

It must also be emphasized that even if Freud never abandoned the notion of psychical bisexuality, he considered the difficulty in connecting the concept to the theory of drives as a serious lacuna in psychoanalytic theory. Thus the “theory of bisexuality is still surrounded by many obscurities” (1930a [1929], p. 106).

Finally, a supplementary problem must be introduced: A deeper understanding of the concept of bisexuality necessarily would not facilitate an under-

standing of the ideas of masculinity and femininity. For as Freud warned us, to give any new content or attach any mental qualities to the concepts of masculine and feminine only gives way to anatomy or to convention: “The distinction is not a psychological one” (1933a [19320, p. 114]). This indicates that as long as a satisfactory psychoanalytic definition of masculine and feminine cannot be found, the notion of bisexuality “embarrasses all our enquiries into the subject and makes them harder to describe” (1940a [1938], p. 188).

PAULO R. CECARELLI

*See also:* Aggressiveness/aggressiveness; Dark continent; Cryptomnesia; Femininity; Femininity, refusal of; Homosexuality; Masculinity/femininity; Object, choice of/change of; Pregnancy, fantasy of; *Sex and Character*; *Three Essays on the Theory of Sexuality*

### **Bibliography**

- Eliade, Mircea. (1963). *Patterns in comparative religion*. (Rosemary Sheed, Trans.). New York: World.
- Freud, Sigmund. (1905d). Three essays on the theory of sexuality. *SE*, 7: 123–243.
- . (1908a). Hysterical phantasies and their relation to bisexuality. *SE*, 9: 156–166.
- . (1923b). The ego and the id. *SE*, 19: 1–66.
- . (1930a [1929]). Civilization and its discontents. *SE*, 21: 57–145.
- . (1933a [1932]). New introductory lectures on psycho-analysis. *SE*, 22: 1–182.
- . (1937c). Analysis terminable and interminable. *SE*, 23: 209–253.
- . (1940a [1938]). An outline of psycho-analysis. *SE*, 23: 139–207.
- . (1950a). The origins of psycho-analysis: Letters to Wilhelm Fliess, drafts and notes: 1887–1902 (Marie Bonaparte, Anna Freud, and Ernst Kris, Eds.). London: Imago Publishing, 1954.

### **Further Reading**

- Elise, Diane. (1998). Gender repertoire: body, mind and bisexuality. *Psychoanalytic Dialogues*, 8, 353–372.
- Ferraro, Fausta. (2001). Vicissitudes of bisexuality: crucial points, clinical implications. *International Journal of Psychoanalysis*, 82, 485–500.

Grossman, Gary (reporter). (2001). Contemporary views of bisexuality in clinical work. *Journal of the American Psychoanalytic Association*, 49, 1361–1378

Smith, Henry. (2002). On psychic bisexuality. *Psychoanalytic Quarterly*, 71, 549–558.

## BIZARRE OBJECT

The term *bizarre object* was coined by Wilfred Bion (1957) to denote a distinctive kind of object existing in the world of the psychotic. By violent projection of unwanted psychic elements, the psychotic personality constructs its universe of bizarre objects. This world is different from the world of part objects containing projections that constitutes the normal world of the paranoid schizoid position as described by Melanie Klein (1946).

The psychotic personality uses a form of splitting and projective identification that is not merely excessive but different, in the aspects of the psyche, especially those ego and superego functions which lead to awareness of reality, are split off, fragmented, and violently expelled into the external world. In this way a hostile conglomerate is formed of aspects of objects with fragments of the psychic apparatus and internal objects. In “The Differentiation of the Psychotic from the Non-psychotic Personalities” (1957), Bion gives examples: “If the piece of personality is concerned with sight, the gramophone when played is felt to be watching the patient; if with hearing, then the gramophone when played is felt to be listening to the patient. The object, angered by being engulfed, swells up, so to speak, and suffuses and controls the piece of personality that engulfs it: to that extent the particle of personality has become a thing” (p. 51). And he concludes: “The consequences for the patient are now that he moves, not in a world of dreams, but in a world of objects which are ordinarily the furniture of dreams.”

EDNA O’SHAUGHNESSY

### Bibliography

Bion, Wilfred. (1957). Differentiation of the psychotic from the non-psychotic. *International Journal of Psychoanalysis*, 38, 206–275.

Klein Melanie. (1946). Notes on some schizoid mechanisms. *International Journal of Psychoanalysis*, 27, 99–110. Republished in M. Klein, P. Heimann, S. Isaacs, and J. Riviere

(eds.). (1952). *Developments in psycho-analysis*. Hogarth. Reprinted in *The Writings of Melanie Klein*, t. III, 1946–1963. (1975). London: Hogarth, pp. 1–24.

## BJERRE, POUL (1876–1964)

A doctor, writer, sculptor, and psychotherapist, Poul Bjerre was the first Swede to develop an interest in Freud and psychoanalysis. He was born in Göteborg on May 24, 1876, and died in Vårsta on July 15, 1964. Bjerre was the son of a Danish businessman and spent his early life in Göteborg, on the west coast of Sweden, where his father had moved his business. Poul Bjerre was the oldest child; his younger brother Andreas, an eminent criminologist, was a professor of criminal law at the University of Dorpat (Lithuania). He committed suicide in 1925.

In 1905 Bjerre married his sister-in-law’s mother. They had no children. His wife, sixteen years his elder, had three children from a previous marriage. In 1906 she fell ill and their marriage remained essentially platonic.

In 1907, after his wife’s death and the completion of his medical studies, Bjerre took over the Stockholm practice of Otto Wetterstrand, a renowned European specialist in hypnosis. Although Bjerre never really abandoned hypnosis, he soon took an interest in psychoanalysis. In December 1910 he traveled to Vienna to meet Freud but the meeting was disappointing. As he was to describe later, he perceived Freud as being cold and distant. His meeting with Alfred Adler was more fruitful, however, and he always felt closer to Jung and Adler, without considering himself anyone’s protégé.

In 1911 Bjerre introduced psychoanalysis to a meeting of the Order of Swedish Doctors. His presentation, which was judged too long for publication in the Swedish medical review *Hygiea*, appeared in *Psyke* a year later, together with articles from other researchers in psychology. However, Bjerre maintained a critical attitude toward psychoanalysis. In 1913 he stated that the conscious mind was more important than the unconscious and criticized Freud during the international congress held in Munich. On several subsequent occasions he expressed satisfaction for having distanced himself early from Freud. At the Munich conference, however, Freud introduced him to Lou Andreas-Salomé, with whom he had a brief but stormy and passionate affair.

When Bjerre introduced psychoanalysis to Sweden in 1924 in an early publication, he included articles not only by Freud but by Adler, Jung, and Alphonse Maeder as well. He concluded the book with one of his own articles in which he explained the evolution of psychoanalysis based on his own research.

Bjerre wrote throughout his life. He wrote a biography of Nietzsche in 1903 and translated from several languages. He was interested in the personality of the celebrated industrial magnate Ivan Kreuger and studied the influence of Hitler's ideas on psychoanalysis. In an article published in 1934 he claimed that the three fundamental works of psychotherapy were Liebeault's *Le Sommeil provoqué*, Freud's *Interpretation of Dreams*, and Hitler's *Mein Kampf*. He had dealings with Jewish and non-Jewish doctors alike and felt that the psychoanalytic movement was pro-Semitic in the same way that Hitler was anti-Semitic. Although he became interested in German culture at a young age, he was not a defender of Nazism.

Six years after the foundation of the Finno-Swedish Psychoanalytic Society in 1940, Poul Bjerre established a psychotherapeutic organization whose administrative directors shared a partial rejection of Freudian theories. Like the other members of the society, Bjerre felt that Freud laid too much stress on the sexual life of the individual and the role of the unconscious, to the detriment of the conscious mind. Moreover, Freudian psychoanalysis was too intellectual and placed too much importance on dream analysis instead of appreciating its curative value and understanding that every individual naturally harbors so-called psychosynthetic conciliatory forces. Early in his career he had, for example, believed that paranoia could be cured by convincing the patient of its absurdity by means of rational arguments, while he maintained the conviction that hypnosis was the best and most effective psychotherapeutic method.

Bjerre never underwent analysis. He could not understand psychoanalysis as a whole and did not practice it. However, he played an essential role in the development of psychoanalysis in Sweden. The majority of Swedish psychoanalysts have, at one time or another, referred to his introduction to Freud's theories.

PER MAGNUS JOHANSSON

*See also:* Sweden.

### **Bibliography**

- Bärmark, Jan, and Nilsson, Ingemar. (1983). *Poul Bjerre, "Människosonen."* Stockholm: Natur och Kultur.
- Johansson, Per M. (1999). *Freuds psykoanalys, arvtagare i Sverige.* Göteborg, Sweden: Daidalos.

---

## **BLACK HOLE**

Frances Tustin introduced the idea of *black holes* in her *Autistic Barriers in Neurotic Patients* (1986). The term was chosen by analogy with ideas in modern astrophysics, which has discovered zones of extraordinary density in the universe that are probably related to the condensation and fusion of several stars. Once formed, such hyperdense zones are thought to exert a sort of attraction upon other stars, which are thus at risk of plunging into the core of these vast concentrations of matter, which swallow them up and strip them of all individuality. It is not hard to see how the metaphor of a "black hole of the psyche" can help explain, or at least help us picture what happens at the core of the psyche of autistic children.

Indeed Tustin had already elaborated on a notion first proposed by Sydney Klein (1980), that of "autistic islands." And, most significantly, in her first book, *Autism and Childhood Psychosis* (1972), she had painstakingly recounted the case of John, who had described to her, on emerging from autism, what he himself called "the black hole w/ the mechant piquant." What John was striving to verbalize in this way was all the pain and suffering he had felt on the occasion of far too brutal and premature a separation between the breast and the nipple, this at a time when nipple and mouth are inextricably conjoined (as described, albeit in a different way, by Piera Aulagnier, with her "complementary zone-object"). Naturally it is less a physical separation that is involved here than a mental one—or even, to be quite precise, the inscription in the psyche of the process of separation.

If, for one reason or another, this process turns out to be impossible or impeded, the child is liable to feel as if a part of him- or herself has been cut off.

This traumatic organization of the psyche leaves its mark in the shape of "autistic islands" which fail to become integrated into the cycles of deferred effects and historical time: Their massiveness and their intensity, in autistic children, are an obstacle to their



becoming part of mental functioning, and they end up serving as pathological poles of attraction for a whole variety of psychic elements which accrete within their sphere of influence and thus become incapable of dispersing in a manner at once orderly and differentiated.

In the wake of Frances Tustin, the post-Kleinian tendency in psychoanalysis has made wide use of the concept of the black hole, extending it to nonpsychotic subjects in whom autistic islands are possible even if in such cases they are less significant and less serious in their implications.

BERNARD GOLSE

*See also:* Autism; Autistic capsule/nucleus; Breakdown.

### **Bibliography**

Klein, Sydney. (1980). Autistic phenomena in neurotic patients. *International Journal of Psycho-Analysis*, 61 (2), 395–401.

Tustin, Frances. (1972). *Autism and childhood psychosis*. London: Hogarth; New York: Science House. Reprinted, London: Karnac, 1995.

———. (1986). *Autistic barriers in neurotic patients*. London: Karnac.

## **BLACKETT-MILNER, MARION (1900–1998)**

Marion Blackett-Milner, a British psychoanalyst, was born in London in 1900 and died there on May 29, 1998.

Born into a scientific family—her brother Patrick Blackett won the Nobel Prize for physics—she first took an interest in education after graduating as a psychologist from the University of London. In 1938 she wrote a book based on her research in educational child psychology, *The Human Problem in Schools*. She married Dennis Milner in 1927 and gave birth to a son in 1932.

Her first book, *A Life of One's Own*, published under the name Joanna Field, appeared in 1934. It was in fact her diary, beginning in 1926, in which she recounted in a remarkably authentic style her observations and discoveries about herself. Her future destiny is already discernible in this autobiographical work. It was followed by two other autobiographical books: *An Experiment in Leisure*, in 1937 and, fifty years later, *Eternity's Sunrise* in 1987. In 1950 she published *On Not Being Able to Paint*, in which she develops a method

that consists of allowing one's hand to wander freely over the paper in order to see what it produces. The drawings thus produced represent not only external objects but also the structure of one's own feelings and thoughts.

She began to train as an analyst in the 1940s while also becoming an enthusiastic painter. She was analyzed by Sylvia Payne, qualified in 1943 and began to practice in London. *The Hands of the Living God*, published in 1969, is one of Milner's most remarkable contributions as a psychoanalyst. It is the complete, marvelously well-written and illustrated story of the treatment of a very ill patient, a moving account of the way in which she communicated her emotions through the medium of drawing whenever words failed her. In the meantime in 1952 she published an article on "the role of illusion in the formation of symbols," in which she does not limit the meaning of the word symbol to a defensive function (Ernest Jones) but stresses its creative potential. She insists on the function of a "malleable" environment in the process leading to recognition of the world outside oneself. She developed the idea of a "medium" between the reality created by oneself and external reality: a sort of modeling clay for the mind, the intermediary between representation and figuration, a malleable substance by means of which impressions are transmitted to the senses and with which we can give shape to our fantasies. Patients model their own creative process through therapists, who recognizes as well in themselves an inside and an outside, a part that is separate and another that is a part of the patient.

Her theories about the separability of the object complement Donald Winnicott's work on the transitional object and the creativity of the baby. In her last work, *The Suppressed Madness of Sane Men. Forty-Four Years of Exploring Psychoanalysis*, published in 1987, she sums up her principle observations and her articles on the relationship between psychoanalysis and creativity.

On May 29, 1998, Marion Milner died in her London home at the age of ninety-eight, while working on another publication. She contributed to our understanding of the mechanisms of symbolization and interpenetration between the subjective and objective world both in art and psychoanalysis, and deepened our knowledge of the processes by means of which the psyche is born of the soma, and of the way

in which we really learn to live and communicate with our bodies. Masud Khan used to say that Milner had “an inexhaustible reserve of energy for living, working, writing, and painting.” She was extremely original and inventive in her own self and in her thinking, as well as being a member of the Independent Group of the British Psycho-Analytical Society. She was passionate about esthetics, creativity in art and analysis, and the role of symbolism in the thinking process. Both her autobiographical and psychoanalytical writings constitute, as Harry Guntrip said about Winnicott, with whom she was very close, “the natural expression of [her] personality.” In it she manifested a total commitment to exploring the inner world and the farthest reaches of the being, at the frontier of the Self and non-Self.

DIDIER RABAIN

*See also:* Representation of affect visual arts and psychoanalysis.

### **Bibliography**

- Milner, Marion. (1969). *The hands of the living god*. New York: International Universities Press.
- . (1987). *The suppressed madness of sane men. Forty-four years of exploring psychoanalysis*. London, New York: Tavistock Publications.
- Parsons, Michael. (1990). Marion Milner’s ‘answering activity’ and the question of psychoanalytic creativity. *International Review of Psychoanalysis*, 17, 4.
- Rayner, Eric. (1991). *The independent mind in British psychoanalysis*. London: Free Association Books.
- Winnicott, Donald W. (1988). *Winnicott studies. The journal of the Squiggle Foundation. A celebration of the life and work of Marion Milner*. London: The Squiggle Foundation.

## **BLANK/NONDELUSIONAL PSYCHOSES**

*Blank psychosis* is defined as a psychosis with no readily identifiable clinical manifestation, where analysis alone affords access to a psychotic core: a nuclear structure that is the source of possible psychotic development without necessarily producing actual symptoms.

Jean-Luc Donnet and André Green (1973) introduced the notion of blank psychosis, based on a

psychoanalytic session with a patient, “Z,” conducted in a general psychiatry department.

As early as 1911, Eugen Bleuler had distinguished “simple schizophrenia” and “latent schizophrenia,” and his notions of “schizoid” and “schizothymia” had already raised the issue of the boundaries of psychosis.

Psychoanalysis first considered the internal boundaries of psychosis in order to fathom its outer limits. Helene Deutsch described the “as if” personality in 1934, and as early as 1939 Maurits Katan studied “prepsychosis” in his work, “A Contribution to the Understanding of Schizophrenic Speech.” Since Otto Kernberg’s 1967 book *Borderline Conditions and Pathological Narcissism*, the study of prepsychosis has often been combined with that of borderline states.

Rather than a syndrome, blank psychosis evokes a structure that is not manifest. It can be mistaken for a depressive state with a configuration that is difficult to pinpoint, for a borderline state, or it can refer to psychotic development without obvious signs. Consistently nuclear, it corresponds to three parameters according to the “princes” description: a) oedipal organization remains triangular, but the two parent figures are identified according to their good or bad character rather than the masculine/feminine opposition; b) object relations bring internal objects into play; c) the subject is torn between good objects and bad objects, and between the good ego and the bad one, on account of the objects being driven back into the ego.

Unlike psychosis, the role of the external objects in blank psychosis shows that the subject continues to cathex reality, which is doubly inscribed, even as projection considerably modifies the subject’s apprehension of it. However, there are strictly speaking no delusions, in the sense of either persecution by the bad object or protection by the good object.

“Empty” or “paralyzed” mental functioning of thought results from an active decaathesis that is attributed to “the destructive drives’ attack on the binding processes in so far as they are a function of consciousness’s awakening to reality” (Kernberg, 1975).

The description of blank psychosis has had an effect comparable to the impact, in the 1970s, of the “borderline” category, linked to the expansion of a North American clinical tradition. The extension of psychoanalytic practice to the treatment of psychosis, and the

surprises generated by this work, have motivated further interest. During the 1960s, Kernberg participated in a long-term study of forty-four difficult cases treated by psychoanalysts at the Menninger Clinic. When psychosis was triggered after several years in the same analytic situation, Kernberg considered such cases to involve “borderline patients” whose “ego is better integrated than in psychotics except where close human relations are concerned” (1975). With regard to both the triggering and the stabilization of psychosis, he focused less on biological continuity than on the structural continuity of the ego’s defensive reactions, from a perspective informed by the work of Anna Freud. He sought to understand the negative factor that undermines the ego’s consistency to a point of critical instability: “All defensive mechanisms also contain the germ of the ego’s destruction” (Kernberg, 1975). Numerous studies of borderline states have similarly focused less on symptoms than on prepsychotic “personalities,” their degree of consistency—albeit paradoxical—or their narcissism.

Meanwhile, Jacques Lacan, faithful to the “formal envelope of the symptom,” demonstrated the importance of “elementary phenomena” (Lacan, 1993, p. 14) in the prepsychotic phase: intuitions, echoes, words, forced gestures, and the like, all of these intermittent and erratic. In the course of the interview, “eclipses” or “blanks” (or even memorization) in the patient’s speech mark an impasse or confusion with regard to the signifier. Lacan unfailingly examined the sudden appearance of any neologism or surface manifestation of the “kernel of dialectical inertia” (p. 22). His criticism of Maurits Katan focused on the reconstruction of the “prepsychotic” phase, and the confusion of levels—imaginary, symbolic, and real—and also on the confusion between “understanding” and “imagining” in Katan’s account. In Lacan’s view, Katan’s and innumerable other conceptions of “borderline states” had made naïve use of Freud’s notions regarding the ego (the second topography) and his text “The Loss of Reality on Neurosis and Psychosis” (1924).

The “sinthomatic” structure described by Lacan in *The Seminar of Jacques Lacan: Book III, The Psychoses* (1955–1956) opened new perspectives on the psychotic kernel, as did Piera Aulagnier’s work on “psychotic potentiality.”

MICHEL DEMANGÉAT

*See also:* Anality; Borderline conditions; Dead mother complex; Intergenerational.

### **Bibliography**

- Freud, Sigmund. (1924). The loss of reality in neurosis and psychosis. *SE*, 19: 180–187.
- Kernberg, Otto. (1975). *Borderline conditions and pathological narcissism*. New York: Aronson.
- Lacan, Jacques. (1966). *Écrits*. Paris: Seuil.
- . (1993). *The seminar of Jacques Lacan: Book III, the psychoses (1955–1956)*. (Jacques-Alain Miller, Ed. and Russell Grigg, Trans.). New York: W. W. Norton.
- Mijolla-Mellor, Sophie de. (1998). *Penser la psychose. Une lecture de l’oeuvre de Piera Aulagnier*. Paris: Dunod.

---

### **BLANTON, SMILEY (1882–1966)**

An American psychiatrist and psychoanalyst, Smiley Blanton was born in 1882 in Unionville, Tennessee, and died on October 30, 1966, in New York. A patient of Freud, his *Diary of My Analysis with Freud* appeared in 1971. Born in the South into a family of strict Presbyterians, he studied medicine at Cornell University, became an M.D. in 1914, and was trained in psychiatry by Dr. A. Meyers at Johns Hopkins hospital in Baltimore. After serving in World War I, he received a degree in neurology and psychological medicine from the Royal College of Physicians and Surgeons in London in 1922–23.

He taught at the University of Minneapolis, where he had created the first child guidance clinic associated with a public school; then, in 1927, created a nursery school at Vassar College in Poughkeepsie, New York. Two years later he moved to New York City, intending to practice psychoanalysis. Through George Amsden, who was leaving to be analyzed by Sándor Ferenczi, he replaced Clinton McCord, who had just finished his analysis with Freud.

The first period of the analysis began on August 31, 1929, in Berchtesgaden, where Freud spent his vacations. Blanton later described his first meeting with Freud: “A small, frail and graying man suddenly appeared and moved toward me to greet me. Although he seemed older than in the photographs I was familiar with, I recognized the silhouette that approached me to be that of Freud. Cigar in hand, he spoke to me almost timidly.”

Blanton took great care in recording Freud's remarks, which were frequent and lengthy; Freud also provided numerous suggestions on analytic technique, avoided interpreting his patient's colitis, asked him not to write down his dreams, and added, "For an analyst not to relate his dreams, now that's a sign of serious resistance!" He would soon involve him in his research concerning Shakespeare's identity.

From September to the end of October, Blanton followed Freud to the Schloss Tegel clinic in Berlin, and then resumed his analysis in Vienna. He was again forced to interrupt his analysis at the end of April when Freud went to the Sanatorium Cottage of Vienna and then to Berlin for treatment of his heart problems. At the end of Blanton's analysis, on May 30, Freud provided him with a letter of recommendation to Ernest Jones: "I would like to introduce you to Dr. Smiley Blanton. He is a pleasant man, especially interested in the orientation of children (Vassar College). He has undergone six months of personal analysis with me; I think he will return home a sincere believer in PsA."

Five years later, in August 1935, Blanton had a further two weeks of analysis with Freud, who was then at his vacation home in Grinzing. Freud accepted payments before the sessions began by saying, "I accept them on account. If I happen to die before the fortnight is over, they will be returned to you!" During the analysis Freud spoke about Ferenczi and technique—Blanton was now seeing patients of his own—signed a copy of the *Interpretation of Dreams* for him, and, when Blanton left on August 17, after expressing his wish to return the following year, responded, "I regret that I cannot promise I will be here . . ."

However, two years later, on August 1, 1937, Blanton was again in Grinzing with Freud. He described him as "more alert and more dynamic than he was two years ago . . . His hearing remains poor, but no more than it was two years ago." While planning a trip to London, their discussion turned to phenomena that Freud was skeptical of, such as parapsychology, "with the exception of telepathy, whose existence is possible and which deserves to be studied."

In London, on August 30, 1938, Blanton saw Freud for a final week of therapy that lasted until September 7, the day before Freud was scheduled for a new operation. Blanton resumed his habit of recording his dreams and investigating the resistance that occurred during their interpretation. As for Freud, "he appeared

to me as dynamic, alert, and lucid as ever." But, Freud confided to him, "At my age it's natural that one thinks of death. Those who think about death and talk about it are those who are not afraid, while those who are afraid neither think about it nor talk about it." Blanton added, on September 5, 1938, "In reading these pages, it will become apparent that the professor spoke often to me of death."

Later in his career, Blanton collaborated with Norman Vincent Peale in establishing the American Foundation of Religion and Psychiatry. They opened the Religio-Psychiatric Clinic at the Marble Collegiate Church on lower Fifth Avenue, where free assistance was offered to people suffering from emotional disturbances such as anxiety and depression. The clinic also trained clergymen of all denominations to help people deal with their emotional difficulties. Blanton and Peale wrote several books together, most notably their first collaboration, *Faith Is the Answer: A Pastor and a Psychiatrist Discuss Your Problems*.

ALAIN DE MIJOLLA

*See also:* Face-to-face situation; Neutrality/benevolent neutrality; Psychoanalytic treatment; Religion and psychoanalysis; Weltanschauung.

### **Bibliography**

Blanton, Smiley. (1971). *Diary of my analysis with Freud*. New York: Hawthorn.

---

## **BLEGER, JOSÉ (1923–1972)**

An Argentine doctor, psychiatrist, and psychoanalyst, José Bleger was born in 1923 in Santiago del Estero, Argentina, and died on June 20, 1972, in Buenos Aires. He was one of the most original of the Argentine school of psychoanalysts. Through his psychiatric research he investigated psychotic phenomena, an interest that was to become the focus of all his later work. He was intimately familiar with the work of Karl Marx and an active militant in the Argentine communist party; he studied psychoanalysis with Enrique Pichon-Rivière.

Bleger conceived of the human being as a social being and affirmed the necessity of questioning the way in which the individual isolates and separates himself

from others rather than the way in which he unites with others and socializes. An overview of these ideas is presented in his *Psicoanálisis y dialéctica materialista*, published in 1958. Ronald Fairbairn was deeply influenced by this theory, and it was through Fairbairn that Bleger was able to confirm that object relations determine the intensity and nature of anxiety as well as defensive strategies and tactics.

It is in *Simbiosis y ambigüedad*, published in 1967, that Bleger describes his most important theoretical concepts and their development. Here, in his psychoanalytic research, Bleger for the first time confronts the subject of symbiosis, generally following Kleinian positional structures. He describes an object that, for this primitive position, he describes as “agglutinated” by fusional anxieties and defenses that correspond to the so-called “glischrocaric” position. He initially attributed these anxieties and defenses to the “psychotic part” described by Wilfred Bion, but he then characterized them as increasingly undifferentiated. This led him to conceive of a step prior to the paranoid-schizoid position described by Melanie Klein.

Psychoanalytic psychopathology changed fundamentally in this theory, which Bleger reformulated in his work on schizophrenia, autism, mania, melancholy, perversion, addiction, and psychosomatic illnesses. The analytical technique concerning the framework, split interpretation, and timing varies depending on the form of the intervention and its participation in the phenomena of restitution.

Bleger also conducted research in the fields of institutional psychology, family psychology, and group phenomena. The problem of Judaism in the USSR turned him into an active militant in favor of the Jewish question and the international political aspects of the denial of freedom. He died prematurely in Buenos Aires at the age of forty-nine, at a time when his work was on the point of reaching its fullest expression.

SUSANA BEATRIZ DUPETIT

See also: Argentina; Framework of the psychoanalytic treatment; Group psychotherapies; Individual; Individuation (analytical psychology).

### **Bibliography**

Bleger, José. (1958). *Psicoanálisis y dialéctica materialista. Estudio sobre la estructura de psicoanálisis*. Buenos Aires: Paidós.

——— (1966). Psycho-analysis of the psycho-analytic frame. *International Journal of Psychoanalysis*, 48 (4), 511–519.

——— (1967). *Simbiosis y ambigüedad; estudio psicoanalítico*. Buenos Aires: Editorial Paidós.

---

## **BLEULER, PAUL EUGEN (1857–1939)**

Paul Eugen Bleuler, a Swiss professor of medicine, holder of the chair of psychiatry at the University of Zurich and director of the university psychiatric clinic of Burghölzli in Zurich (1898–1927), was the son of Johann Rudolf Bleuler and Pauline Bleuler-Bleuler. Born April 30, 1857, near Zurich, he died July 15, 1939. Bleuler came from a family of well-to-do farmers. He went to several schools, then studied medicine in Zurich, graduating in 1881. From 1881 to 1884 he was an assistant physician at the university psychiatric clinic of Waldau-Bern. From 1884–1885 he went to Paris to study with Charcot and then to London and Munich, where he studied with Gudden. From 1885 to 1886 Bleuler worked as an assistant physician to August Forel at Burghölzli. From 1886 to 1898 he was director of the psychiatric clinic of Rheinau-Zürich, finally assuming the position formerly held by Forel in Burghölzli in 1898, where he remained until 1927.

His first scientific contact with Freud occurred in 1892, during his work on aphasia. In 1896 Bleuler prepared a favorable report on Breuer and Freud’s work, *Studien über Hysterie (Studies on Hysteria, 1895)*. The first correspondence with Freud took place in 1898. In 1900 Bleuler asked his assistant, Carl Gustav Jung, for a report on the *Interpretation of Dreams* (1900) for the clinic. Extensive correspondence between Freud and Bleuler did not begin until 1904, however. Moreover, it was through Jung’s work and therapeutic success, between 1900 and 1909, that Bleuler came to appreciate the possibilities and usefulness of Freudian psychoanalysis. His liberal attitude and open-mindedness only make sense when we consider the influence of August Forel, who saw himself as the vehement defender of hypnotherapy, a man open to a dynamic, scientific, and public comprehension of psychic pathologies (Forel himself was a violent critic of Freudian ideas).

Bleuler’s publications between 1906 and 1911 reveal his caution—not entirely uncritical—regarding Freud’s work. In 1907, under his direction, the Freudian Association of Zurich was founded at his clinic. Through his work and attitudes, Bleuler unleashed a storm of

scientific criticism, especially in German and Swiss psychiatric circles. He also had to withstand personal attacks from those close to him, including Forel and Constantin von Monakow. Additionally, there was pressure from Freud and Jung who, impelled by tactical interests, wanted to secure his active participation in the Zurich regional branch of the International Psychoanalytic Association. These efforts came to a head during a meeting between Freud and Bleuler in December 1910 in Munich. Bleuler's ambivalence, often hinted at and now out in the open after Freud read his article "Die Psychoanalyse Freuds" (Freud's psychoanalysis; 1911), can be explained by the number of constraints that impeded his desire for knowledge and his critical scientific mind. Bleuler was unable to overcome these conflicts and after eleven months he gave up his position. With his "Kritik der Freudischen Theorien" (1913), he lost his position in the orchestra of Freudian science. That same year he, along with Jung, gave up his responsibilities in psychoanalytic circles. Unlike Jung, Bleuler maintained a distant but polite relationship with Freud.

Bleuler's scientific contribution to psychoanalysis is modest. But the scope of his influence, which should not be underestimated, is largely based on his political and medical activities. Through his personality and responsibilities, Bleuler opened the doors of international scientific discourse to Freud and psychoanalysis. "After this it was impossible for psychiatrists to ignore psychoanalysis any longer. Bleuler's great work on schizophrenia (1911), in which the psychoanalytic point of view was placed on an equal footing with the clinical systematic one, completed this success" (Freud, 1914d, p. 28)

BERNARD MINDER

*See also:* Ambivalence; Autism; Burghölzli Clinic; *Jahrbuch der Psychoanalyse*; Jung, Carl Gustav; Paired opposites; Schizophrenia; Switzerland (German-speaking); Word association.

### **Bibliography**

Bleuler, Eugen. (1892). Zur Auffassung der subcorticalen Aphasien. *Neurologisches Zentralblatt*, 18, 562–563.

———. (1896). Buchanzeige über Breuer-Freuds "Studien über Hysterie." *Münchener medizinische Wochenschrift*, 22, 524–525.

———. (1911). Dementia præcox, oder die Gruppe der Schizophrenien. *Aschaffenburg, Handbuch der Psychiatrie*. Leipzig: n.p.

———. (1913). Die Kritik der Freudschen Theorie. *Allgemeine Zeitschrift für Psychiatrie und psychisch gerichtliche Medizin*, 52 (5), 665–718.

Freud, Sigmund. (1914d). *On the history of the psychoanalytic movement*. SE, 14: 7–66.

---

### **BLOC—NOTES DE LA PSYCHANALYSE, Le**

Created in 1981 by Mario Cifali, its director, *Le Bloc—Notes de la psychanalyse*, published by Éditions Georg, in Geneva, is a Freudian review affiliated with the work of the seminar of the Cercle Freudien. There is a relation between Lacan's 1975 conference in Geneva before the Swiss Psychoanalytic Society—Raymond de Saussure center—and the creation of the review. It was further promoted by Serge Leclair's suggestion to found a study center for psychoanalysis in Geneva. The center was intended for young people with sufficient background to investigate Freudian ideas. Jenny Aubry, Roger Lewinter, François Perrier, George Dubal, Michel de Certeau, Mireille Cifali, Monique Schneider, Françoise Dolto, and Conrad Stein all gave their approval to the initiative.

Along with theoretical and clinical articles written by psychoanalysts from the various schools, *Le Bloc—Notes de la psychanalyse* has presented unpublished historical documents. These include the correspondence between Freud and Otto Rank concerning the book *The Trauma of Birth* (issue 10) and the interview between Max Graf, the father of "Little Hans," and Kurt Eissler (issue 14). Three issues of the review were particularly sought after by readers: "Éducation, médecine, place de la psychanalyse" (issue 7), "Les traumatismes psychiques" (issue 12), and "Le père" (issue 13).

MARIO CIFALI

---

### **BLOCH, JEAN-RICHARD (1884–1947)**

Jean-Richard Bloch was a writer, historian, and socialist propagandist. He founded the socialist review *L'effort* in Poitiers in 1910, collaborated with the publisher Frédéric Rieder, and edited the newspaper *Ce soir* with Louis Aragon. He was the first French editor to publish articles of a psychoanalytic nature.

Born in Paris into a Jewish family that had settled in Auxerre (Yonne) in the eighteenth century, he studied history at the Sorbonne (with Charles Seignobos), received his teaching degree in 1907, and was appointed to the lycée in Lons-le-Saulnier, then in Poitiers (1909). He collaborated with Gaston Thiesson and Dr. René Morichau-Beauchant, his friend for many years, in producing *L'effort*, a “journal of struggle and ideas.” Morichau-Beauchant was the psychology and psychiatry editor for the review.

In *L'effort* Bloch presented Morichau-Beauchant's very first article on psychoanalysis, “L'inconscient et la défense psychologique de l'individu” (The unconscious and the psychological defense of the individual; 1910), published a year before his “Le rapport affectif dans la cure des psychonévroses” (The affective relationship in the treatment of psychoneuroses; 1911). He later published three additional articles by this same author. A reader of Freud, Bloch himself wrote an article entitled “La mort d'Œdipe” (The Death of Oedipus), followed by two novels, *La nuit Kurde* (1925; *A Night in Kurdistan*, 1931) and *Sybilla* (1935), where the influence of analysis is obvious. Writing *La nuit Kurde* had a therapeutic effect on its author: “I have to complete my work... I have overcome my neurasthenia, my apprehension; I have taken back possession of my ego.”

MICHELLE MOREAU RICAUD

*See also:* Morichau-Beauchant, Pierre Ernest René.

### **Bibliography**

- Bloch, Jean-Richard. (1912). *Lévy: Premier livre de contes*. Paris: Gallimard.
- . (1918). . . . *et compagnie*. Paris: Gallimard. (Reprinted 1997.)
- . (1931). *A Night in Kurdistan* (Stephen Haden-Guest, Trans.). New York: Simon and Schuster. (Original work published 1925)
- . (1931). *Destin du siècle: Essais pour mieux comprendre son temps*. Paris: Rieder. (Reprinted, Paris: Presses Universitaires de France, 1996.)
- Morichau-Beauchant, René. (1910). L'inconscient et la défense de la vie. *L'effort*, 1.
- . (1911). Le rapport affectif dans la cure des psychonévroses. *Gazette hôpitaux*, 84 (14), 1845–1849.

## **BLOS, PETER (1904–1997)**

A German psychoanalyst with a degree in education and a PhD in biology, Peter Blos was born February 2, 1904, in Karlsruhe (Germany), and died June 12, 1997, in Holderness, New Hampshire (United States). Blos's childhood and adolescence were marked by the spiritual influence of his father, a doctor drawn to Gandhi's ideas. Early in life he became a friend of Erik Homburger, who later became the psychoanalyst Erik Erikson. Blos studied education at the University of Heidelberg to become a teacher, and then obtained a doctorate in biology in Vienna.

During the 1920s, he was introduced to Anna Freud, who asked his help in creating a school for children undergoing analysis. The project was supported and encouraged by Eva Rosenfeld and Dorothy Burlingham, a friend of Anna Freud, whose children attended the small school. Blos invited Erik Homburger to join him there. Within the Vienna psychoanalytic circle August Aichhorn exerted considerable intellectual influence on Blos, which strongly affected his psychoanalytic training. Blos entered psychoanalysis through teaching, while giving his work an orientation and sensitivity influenced by spirituality.

To escape the rise of Nazism, Blos fled Vienna in 1934 for the United States, where he settled in New Orleans. There he was hired as a teacher in a private school, before leaving for New York, where he continued his analytic training. According to Aaron H. Esman, he became a member of the New York Psychoanalytic Society, becoming a special member in 1965 and then a supervisor and trainer. As a teacher he introduced, in 1972, a course on delayed adolescence, which he discontinued in 1977. He continued his clinical practice and did some teaching at the Columbia Psychoanalytic Center as cofounder of the Association of Child Psychoanalysis. When he retired from professional life, he spent his time writing poetry and fiction, playing the violin, and practicing carpentry in his country home in Holderness, New Hampshire. He died there at the age of ninety-three, by the side of his second wife.

Of his four published books, it is *On Adolescence: A Psychoanalytic Interpretation* that led to his national and international recognition. This book, supported by his extensive clinical experience with adolescents, picks up the thread of an idea that Sigmund Freud failed to develop. Freud identified the beginning and end of the

process of puberty, largely ignoring the intermediary stages. Blois decided to elucidate the various stages of development of the personality, from latency to post-adolescence. His goal was to present a unified theory of adolescence, a necessary first step in introducing an adolescent-specific psychopathology and psychotherapeutic technique. Five years later he developed a key concept, inherited from the work of Margaret Mahler, the “second individuation process.” Here, the emphasis is on the importance of renegotiating the separation with the parents’ imagos during adolescence. The author emphasizes the importance of gaining access to regression, which, contrary to what occurs in the case of the infant and the adult, is tied to the ego.

The second individuation process is what made Blois well-known. His theoretical and clinical approach to the gradual development of the personality, delinquency, and the problems of the ego (superego, ego ideal, integrative capability) also made a significant contribution to understanding adolescence. In the United States he is considered an eminent specialist, a forerunner of child and adolescent analysis, who trained several generations of analysts in adolescent psychotherapy.

FLORIAN HOUSSIER

*See also:* Adolescence; Adolescence crisis; Hietzing Schule/Burlingham-Rosenfeld School.

### **Bibliography**

- Blois, Peter. (1962). *On adolescence: A psychoanalytic interpretation*. New York: The Free Press.
- . (1967). The second individuation process of adolescence. *Psychoanalytic Study of the Child*, 162–186.
- . (1978). The concept of acting out in relation to the adolescent process. In E. Rexford (Ed.), *A developmental approach to the problem of acting out* (p. 153–174). New York: International Universities Press.
- . (1985). *Son and father*. New York: The Free Press.
- Eisman, Aaron H. (1997). Obituary of Peter Blois. *International Journal of Psycho-Analysis*, 78, 813–814.

## **BODY IMAGE**

In psychoanalysis, *body image* is the mental representation one has of oneself, which gradually develops in each individual. The body image encompasses fantasies, especially unconscious fantasies, and also involves the environment. The body is one of the subjects Freud dealt with most frequently. In several of his papers, he referred to the constitution and development of the erogenous zones, their representations and importance in the formation of the body image.

The body image is constantly being created and recreated. Caresses and the first affectionate contacts with the people who surround the child during infancy are responsible for molding the body image, and return to the child the image of his own body through containment and eye contact. This is a dialectic process, in which the environment also plays a role. Piera Aulagnier (1991) says that to transform a sensitive region of the body into an erogenous zone, the physiologically sensitive reaction is not enough: time and subjective interrelation are required for the signs of somatic life to become signs of psychic life. In his work on the mirror phase, Jacques Lacan (1949/2004) describes a mechanism of identification that is established through the transformations that occur in infants when presented with a reflection: The mirror offers a tempting image of comprehensive unity, representing what is felt to be a precarious and fragmented self. It was Esther Bick (1968) who, on the basis of clinical material, studied the development of the concept of the skin and its relationship with introjection and projective identification. Didier Anzieu (1985) calls *moi-peau* (skin-ego) the image of the ego the infant uses in the course of the early phases of his development to represent himself as an ego, on the basis of experiences connected with the body surface.

Various models or clinical hypotheses, such as the neurotic body image, and the primitive-psychotic body image, may be postulated on the basis of clinical psychoanalytical work. The neurotic body image, closer to the notion of normalcy, is the unconscious mental representation of the skin, complete and whole, which envelops and contains warmly. This skin represents the mother’s and father’s support and warmth, which are in turn the basis for the containment of the self and the limits of the body image. Conversely, in the model of the primitive-psychotic body image, there is no notion

**BLUSHING, FEAR OF.** *See* Erythrophobia



of skin, but instead the notion of fluid as the nucleus of the primitive-psychotic body image. Thus, there is only a vague psychological notion of a wall that contains vital fluids, or blood, and fantasies of bleeding, or “emptying out” of those vital fluids. Sometimes this emptying out is linguistically expressed in a fast, uncontrolled speaking style.

This means that the primitive-psychotic concept of the body breaks through and invades what up to then was a different type of mental functioning. These experiences may be expressed through words or through body language, as in psychosomatic disorders. Some patients may have hypochondriac ideas related to the primitive-psychotic body image, such as alleged blood infections, leukemia or hemophilia.

Some concepts related to body image are: hypochondria, body fragmentation, delusions of denial of parts of the body (known as Cottard’s delusion), and somatic delusion. Hypochondria based on the psychotic primitive body image may lead to suicidal accidents.

DAVID ROSENFELD

*See also:* Anorexia nervosa; Bulimia; Demand; Depersonalization; Imaginary identification/symbolic identification; Mirror stage; Object *a*; Puberty; Schilder, Paul Ferdinand; Self-image; Tube-ego; Want of being/lack of being.

### **Bibliography**

- Anzieu, Didier. (1985). *The skin ego*. New Haven-London: Yale University Press.
- Aulagnier, Piera. (1991). *Un interprète en quête de sens*. Paris: Payot.
- Bick, Esther. (1968). The experience of the skin in early object relations. *International Journal of Psycho-Analysis*, 49, 558–566.
- Lacan, Jacques. (2004). The mirror stage as formative of the *I* function, as revealed in psychoanalytic experience. In his *Écrits* (pp. 3–9; Bruce Fink, Trans.). New York: W. W. Norton. (Original work published 1949)
- Rosenfeld, David. (1992). *The psychotic aspects of the personality*. London-New York: Karnac Books.

### **Further Reading**

- Greenacre, Phyllis. (1953). Certain relationship between fetishism and the faulty development of the body image. *Psychoanalytic Study of the Child*, 8, 79–98.

Meissner, William W. (1997). The self and the body: The body self and the body image. *Psychoanalysis and Contemporary Thought*, 20, 419–448.

———. (1998). The self and the body: III. The body image in clinical perspective. *Psychoanalysis and Contemporary Thought*, 21, 113–146.

---

## **BOEHM, FELIX JULIUS (1881–1958)**

German physician, a specialist in neurological and mood disorders, psychoanalyst and president of the German Psychoanalytic Association (DPG), Felix Boehm was born in Riga on June 25, 1881, and died in Berlin on September 20, 1958. Remembered more as a practical psychotherapist than as a theorist, Boehm was an “Aryan” member of the psychoanalytic community during the Nazi era.

Boehm’s father, Paul, was an industrialist originally from Fürstenwalde; his mother, Luise, née Zelm, was the daughter of merchants. His brother, Paul Boehm (1879–1951) took over his father’s business, while Edgar Boehm (1889–1922) became an architect in Berlin. All three brothers were associated with the “Rubonia Clique,” a group of Baltic Germans, and so became acquainted with Alfred Rosenberg, who would become the principal ideologist of National Socialism and was ultimately sentenced to death at Nuremberg.

Boehm studied engineering in Munich before pursuing medical studies in Geneva, Freiburg im Breisgau, and Munich. Among his teachers were F. von Müller, Emil Kraepelin, and Ernst Cassirer. He was analyzed by a Polish student of Freud, Eugenia Sokolnicka, and became a member of the Munich regional group of the International Psychoanalytical Association in 1913. In 1914 he married B. E. Welsch, with whom he had three children. Enlisting as volunteer doctor during the First World War, he was promoted to chief physician and served as a psychiatric expert in a war tribunal held in Gernersheim.

In 1919 Boehm settled in Berlin and began an analysis with Karl Abraham, taking a doctorate in 1922, with a thesis on “Two Cases of Delirium by Arteriosclerosis.” He taught at the Berlin Psychoanalytic Institute from 1923 to 1933, set up scholarships at the Institute, and collaborated with the newly founded Berlin Psychoanalytic Polyclinic. Boehm placed his daughters into a prophylactic psychoanalysis with Melanie Klein. In 1928 he began studies in ethnology and worked with Eckhard von Sydow, a philosopher and art historian.

After Hitler's accession to power and the Nazis' immediate efforts to discredit psychoanalysis, Max Eitington resigned as president of the DPG and Boehm, viewed by Freud as "so-so," took his place. Viewing his role as "savior of psychoanalysis," he served as president of the DPG from 1933 to 1936 and as director of the Berlin Psychoanalytic Institute. He advocated harsher racial laws and expelled Jews from the DPG in December 1935. The next year Boehm was appointed to the administrative board of the German Reich's Institute for Psychological Research and Psychotherapy (Göringinstitut); however, despite his cooperation with the National Socialist authorities, he was not longer allowed to conduct didactic analyses.

Beginning in 1939, Boehm directed a research team that investigated homosexuality, always one of his main interests, and undertook a follow-up study of the institute's polyclinic patients. From 1941 to 1945, as health officer and expert in service to the Wehrmacht, Boehm took part in sentencing to death "malingerers," deserters, and homosexuals.

After the war, in 1947 Boehm was one of the founders of the Institut für Psychotherapie, and in 1949 he was appointed director of instruction and training policy for educational psychology. In 1950 Boehm became president of the reconstituted DPG which, to his considerable disappointment, was refused admission to the International Psychoanalytic Association.

REGINE LOCKOT

*See also:* Berliner Psychoanalytische Poliklinik; Berliner Psychoanalytisches Institut; Deutsches Institut für Psychologische Forschung und Psychotherapie (Institut Göring); Germany; Phallic woman.

### **Bibliography**

- Bibring, Grete. (Ed.). (1951). Report on the 17th International Psychoanalytical Congress. *International Journal of Psychoanalysis*, 33, 249–251.
- Boehm, Felix. (1978). *Schriften zur Psychoanalyse*. Munich: Ölschläger.
- Cocks, Geoffrey. (1985). *Psychotherapy in the Third Reich: The Göring Institute*. New York: Oxford University Press.

## **BONAPARTE, MARIE LÉON (1882–1962)**

Marie Bonaparte, a French psychoanalyst, founding member of the Paris Psychoanalytic Society, and

princess of Greece and Denmark, was born on July 2, 1882, in Saint-Cloud, France, and died on September 21, 1962, in Saint-Tropez. She was the only daughter of Prince Roland Bonaparte (great nephew of Napoléon Bonaparte) and Marie-Félix Blanc (who died a month after her birth). In 1907 she married Prince Georges of Greece and Denmark, with whom she had two children, Eugénie and Pierre.

The melancholic preoccupation of her writings attests to her state of mind. René Laforgue wrote in a letter to Freud that she suffered from an obsessive neurosis that did not affect her intellect but slightly disturbed her mental equilibrium. Bonaparte herself wrote, "At times I have the sensation of catastrophe. I wish an unknown star would destroy the planet." Dissatisfied with her life, she found solace in her imagination.

In 1924 Bonaparte published a collection of stories, *Le Printemps sur mon jardin* (Spring in my garden). Using the pseudonym A. E. Narjani, she wrote an article describing clitoral surgery entitled, "Considération sur les causes anatomiques de la frigidité chez la femme" (Consideration of the anatomical causes of frigidity in women). Later, the disappointments of her sexual and emotional life were reflected in her symbolic novel *Les glauques aventures de Flyda des Mers* (The sad adventures of Flyda des Mers).

Although she gave expression to her adult problems in her novels and essays, her other writings described the vicissitudes of her childhood. Raised by a nurse, she filled her child's world with imaginary characters whose adventures she described in small notebooks with black covers she called her "Bêtises" (Whimsies). Around the time of her father's death on April 14, 1924, she rediscovered them. On her father's nightstand she found a copy of Freud's *Introductory Lectures on Psychoanalysis* (1916–1917a [1915–17]).

Bonaparte began an analysis with Freud on September 30, 1925. She used her childhood writing to reinforce her creative work. In 1939 she began to publish facsimiles of her childhood writings together with her psychoanalytically informed commentaries on them.

As a result of her work with Freud and the friendship and confidence that developed between them, Bonaparte soon became his representative in the French psychoanalytic world, which was then being organized. In 1926, with the help of Eugenie Sokolnicka, René Laforgue, Rudolph Loewenstein, René Allendy,

Edouard Pichon, and others, she founded the Société psychanalytique de Paris (Paris Psychoanalytic Society). As Freud's advocate, she firmly resisted the psychiatrists of Saint-Anne's Hospital, who were drawn to a form of French psychoanalysis swept clean of "Germanic slag."

She translated several of Freud's works, including *Leonardo da Vinci and a Memory of His Childhood* (1910c), *An Autobiographical Study* (1925d [1924]), *Jokes and Their Relation to the Unconscious* (1905c), *The Future of an Illusion* (1927d), "Prospectus for 'Schriften zur angewandten Seelenkunde'" (1907), and some of his papers on metapsychology.

Bonaparte's research on applied psychology, society, war, criminality, and female sexuality were published in the *Revue française de psychanalyse*, which she founded with René Laforgue, Angelo Hesnard, and Edouard Pichon. In the first issue of the journal, Bonaparte published her paper "Le cas de Mme Lefebvre," which describes the oedipal crime of a woman who murders her pregnant daughter-in-law. The paper also affirmed Bonaparte's opposition to and condemnation of the death penalty.

Bonaparte's two volume study of Edgar Allan Poe appeared in 1933. She divided his life and work into distinct cycles, which may be seen in her life as well. She characterized these cycles as cycles of the mother: the living-dead mother, the landscape mother, the murdered mother; and as cycles of the father: the revolt against the father, the conflict with consciousness, and passivity toward the father.

Anna and Sigmund Freud translated her book *Topsy: The Story of a Golden-Haired Chow*, illustrated with photographs taken by her daughter, Eugénie, into German. In June 1938, with the assistance of the American ambassador William Bullitt, Bonaparte helped Freud and his family leave Nazi Austria. During World War II, between 1941 and 1944, Bonaparte lived in Cape Town, South Africa, where she wrote articles about the myths of warfare.

Her talks at the Institut de psychanalyse de Paris (Paris Institute for Psychoanalysis) and her articles were published in the *Revue française de psychanalyse* and, after the war, were collected into several volumes: *Psychanalyse et biologie* (Psychoanalysis and biology; 1952), *Introduction à la théorie des instincts* (Introduction to the theory of instincts; 1951), *Psychanalyse*

*et anthropologie* (Psychoanalysis and anthropology; 1952).

In *Female Sexuality* (1951/1953) she compared the libidinal evolution of the sexes. After a shared anal phase of passivity toward the mother, the young girl experiences a temporary phallic phase toward the mother, followed by a second (cloacal and phallic) phase of passivity toward the father. The final genital phase is passive and is accompanied by a relative exclusion of the phallus and affirmation of the vagina. Bonaparte insisted that the father had an important and beneficial role to play in the quality of the love expressed toward the daughter. When a young woman fails to make the transition from clitoral sadism to vaginal masochism in her sexual development, there are two types of alloplastic adaptation available: the Halban-Narjani operation, which involves surgically moving the clitoris toward the vagina, and psychoanalysis, which alone is capable of relaxing the young woman's intense fixation on the phallic clitoris.

During the 1950s, as vice president of the International Psychoanalytical Association, Bonaparte defended Margaret Clark-Williams, who was accused of illegally practicing medicine, and tried to save the life of Caryl Chessman, who had been condemned to death in the United States. Through her generosity a library and institute of psychoanalysis were created in 1954 in Paris. During the schism within the Société psychanalytique de Paris in the 1950s, she supported Sacha Nacht, though without much optimism, in his dispute with Jacques Lacan.

The first two volumes of her memoirs, *Derrière les vitres closes* (Behind closed doors) and *L'appel des sèves* (The call of life), were published in 1953. Prince George of Greece, her husband and "old companion," died on November 25, 1957. In 1959 she presented her final paper, "Vitalisme et psychosomatique" (Vitalism and psychosomatics) to the Twenty-First International Psychoanalytic Congress. She died on September 21, 1962, of leukemia in Saint-Tropez, where she maintained her summer home, Le Lys de Mer, named after the plant.

JEAN-PIERRE BOURGERON

See also: Autobiography; Berman, Anne: Congrès des psychanalystes de langue française des pays romans; France; *Gesammelte Werke*; *Revue française de psychanalyse*; Société

psychanalytique de Paris and Institut de psychanalyse de Paris.

### Bibliography

Bertin, Célia. (1982). *Marie Bonaparte, la dernière Bonaparte*. Paris: Perrin.

———. (1982b). *Marie Bonaparte, a life*. San Diego: Harcourt Brace Jovanovich.

Bonaparte, Marie. (1949). *The life and works of Edgar Allan Poe, a psycho-analytic interpretation* (John Rodker, Trans.). London: Imago Pub. Co. (Original work published 1933)

———. (1951). *Introduction à la théorie des instincts; De la prophylaxie infantile des névroses*. Paris: Presses Universitaires de France.

———. (1952). *Psychanalyse et anthropologie*. Paris: Presses Universitaires de France.

———. (1952). *Psychanalyse et biologie*. Paris: Presses Universitaires de France.

———. (1953). *Female sexuality* (John Rodker, Trans.). New York: International Universities Press. (Original work published 1951)

Bourgeron, Jean-Pierre. (1993). *Marie Bonaparte et la psychanalyse à travers ses lettres à René Laforgue et les images de son temps*. Geneva: Champion-Slatkine.

———. (1997). *Marie Bonaparte*. Paris: Presses Universitaires de France.

---

**BONNEUIL.** See *École Experimentale de Bonneuil*

---

### BOOK OF THE IT, THE

Groddeck's *Book of the It*, first published in 1923 by the Internationaler Psychoanalytischer Verlag, was a great success. It was followed by a second and third edition in 1926 and 1934. Translations exist in Dutch, Swedish, English, French, Italian, Spanish, and Japanese.

*The Book of the It* is written in the form of an epistolary novel. The fictional author of the letters is the psychoanalyst Patrick Troll, and the fictional addressee is a lady who wishes to learn, in a playful manner, about psychoanalysis. Groddeck wanted to present his 1916

and 1919 conferences and psychoanalytic concepts in a popular work. He wrote the letters in 1921 and sent them to Freud, whose response was very encouraging ("Their style is fascinating; their tone musical, clever, and impertinent"). At the request of the reading committee, Groddeck made some cuts, though with some reluctance.

What is remarkable about *The Book of the It* is, first, the content and, second, the presentation. Groddeck highlights the new concepts introduced by psychoanalysis: the infantile, the Unconscious, primary processes, sexuality. He defends the position of Friedrich Nietzsche in *Beyond Good and Evil* on public discussion of humanity's many perverse tendencies. He describes the illnesses of the body and of the mind as products of the It. He thus opens up a "space for illness" (Chemouni, 1984), a place where the individual It deploys itself under the constraint of symbolizations and associations and where analytic treatment can begin to unfold between the analyst and the patient.

The whole of *The Book of the It* is an analytic experience, a game that stimulates with its clinical illustrations, reflections, and fragments of self-analysis that Groddeck uses to involve the reader in the dialog. The individual is controlled by the all-powerful It, the role of the body and mind being to express It. There is nothing we can say about the It; we cannot grasp it theoretically; we can know it only through its accomplishments.

Freud used the concept of It in his metapsychology, and ego psychology enlarges its theoretical scope. Only in the course of the last few decades we have begun to understand and appreciate the significance of Groddeck's original contribution to psychoanalysis.

HERBERT WILL

See also: Id; Groddeck, Georg Walther; Psychosomatic.

### Source Citation

Groddeck, Georg. (1923). *Das Buch vom Es: Psychoanalytische Briefe an eine Freundin*. Leipzig: Internationaler Psychoanalytischer Verlag; München: Fischer Taschenbuch, 1984. *The Book of the It*. Washington: Nervous and Mental Disease Publishing Co., 1928. *The Book of the It: Psychoanalytic Letters to a Friend* (V. M. E. Collins, Trans.). New York: Funk and Wagnalls, 1950.

### **Bibliography**

- Chemouni, Jacquy. (1984). *Georg Groddeck, psychanalyste de l'imaginaire: psychanalyse freudienne et psychanalyse groddeckienne*. Paris: Payot.
- Lewinter, Roger. (1990). *Georg Groddeck: Studien zu Leben und Werk*. Frankfurt am Main: S. Fischer.
- Mannoni, Maud. (1979). *La théorie comme fiction: Freud, Groddeck, Winnicott, Lacan*. Paris: Le Seuil.
- Roeder von Diersburg, Egenolf. (1961). Georg Groddeck's Philosophie des Es. *Zeitschrift für philosophische Forschung*, 15, 131–138.
- Roustang, François. (1976). *Un destin si funeste*. Paris: Minuit.
- Will, Herbert. (1985). Freud, Groddeck und die Geschichte des "Es." *Psyche*, 150–169.

---

## **BORDERLINE CONDITIONS**

The nosological concept of *borderline conditions* (or states) arose from what was defined in the English-language literature as "borderline personality organization," a term used to refer to a wide range of patients whose symptoms could not be explained in terms of either neurosis or psychosis.

There are three common misconceptions concerning borderline conditions to be avoided if their dynamics are to be understood, the first two of which arise from the term itself:

- that they exist at the "borderline" of neurosis or psychosis or constitute a transition between the two, when in fact they are neither pre-psychoses nor severe neuroses;
- that they are transitory "states" because of the various forms in which they can manifest within one individual. Otto Kernberg (1975) prefers to use the term "borderline organization" because, as Daniel Widlöcher (1979) emphasizes, this is an unstable condition existing within a stable structure;
- finally, that the wide variety of clinical manifestations eliminates any need to define the fundamental psychodynamics that these conditions have in common.

The borderline condition is more than a pathology that consists more often in manifest behavior than

internal suffering and in an attitude of object-dependency that, depending on the level of mentalization, can range from drug addiction to violent passages to the act in the "psychopathic" subject. This disorder can produce a wide range of visible manifestations, including extraordinary lapses of consciousness, an "as-if" mode of existence with loss of feeling, and an indefinable state of inefficacy. This range nevertheless stems from the same narcissistic rationale, the same archaic reaction, and a similar way of establishing the required defenses in the outside world.

The narcissistic component of the borderline condition restricts the experience of conflict to its traumatic impact. The Oedipus complex is overcome without having been resolved (Bergeret); however, the narcissistic disorder is neither a depression nor a form of neurotic or psychotic decompensation experienced as an object loss. This in no way detracts from the archaic nature of the need, the intolerance of frustration, the intensity of the rage, or the violence of the reaction. Accordingly, the pregenital quality of the need becomes a threat to an object that is absolutely necessary but has become frightening through projection—an object both that needs protection and from which protection has to be sought.

In the context of such a risk and this overwhelming atmosphere, the borderline patient actively strives to deal with reality rather than to negotiate the drive. Given the impossibility of dissociating the affect from the representation in a way that would enable repression and displacement to occur, and in the absence of an internal object that would be the guarantor of subtle difference, everything is organized in the external world so as to secure the object. Accordingly, this demonstrates the radical choice that the subject has to make in using the denial of the reality that he is able to perceive but not cathect to avoid any conflict. This subject also deploys splitting and—to avoid any internal conflict between love and aggression—completely separates good from bad in the external world or intensely idealizes the object on which he cannot rely.

The concept of omnipotence provides the key to a better understanding of a wider range of manifestations in borderline conditions, including that which characterizes the deeper disorder beneath the neurotic exterior, which ranges from unstable behavior to anti-social reactions and also extends from childish personalities and depressive tendencies to what is described

as narcissistic perversion. Heinz Kohut (1971) classified the megalomania in borderline conditions as one of the “archaic narcissistic configurations” that exist in the Self, which is considered not as an agency of the psychic apparatus but at the very least as a structure in which the representations retain a degree of autonomy in relation to the rest of the life of the drives.

In sum, the borderline condition remains an entirely external striving that results from an incapacity to tolerate internal ambivalence, which produces both the economy of depression at the internal level and the economy of delusion at the external level.

AUGUSTIN JEANNEAU

*See also:* Abandonment; Act, passage to the; As if personality, the; Character neurosis; Dependence; Developmental disorders; Narcissistic injury; Narcissistic neurosis; Negative therapeutic reaction; Prepsychosis; Psychoanalytical nosography; Psychotic/neurotic; Transference hatred.

### **Bibliography**

- Bergeret, Jean. (1975). *La dépression et les états limites*. Paris: Payot.
- Kernberg, Otto F. (1975). *Borderline conditions and pathological narcissism*. New York: Jason Aronson.
- Kohut, Heinz. (1971). *The analysis of the self*. New York: International Universities Press.
- Misès, Roger. (1990). *Les Pathologies limites de l'enfance*. Paris: Presses Universitaires de France.
- Widlöcher, Daniel. (1979). Preface to O. Kernberg, *Les troubles limites de la personnalité*. Toulouse: Privat.

### **Further Reading**

- Abend, Sander, Porder, Michael, and Willick, Martin. (1983). *Borderline Patients: Psychoanalytic Perspectives*. New York: International Universities Press.
- Freud, Anna. (1956). The assessment of borderline cases. In *Writings* (Vol. 5, pp. 301–314). New York: International Universities Press.
- Gabbard, Glen. (2001). Psychodynamic psychotherapy of borderline personality disorder. *Bulletin of the Menninger Clinic*, 65, 41–57
- Fonagy, Peter. (2000). Attachment and borderline personality disorder. *Journal of the American Psychoanalytic Association*, 48, 1129–1146.

Knight, Robert P. (1953). Borderline states. *Bulletin of the Menninger Clinic*, 17, 1–12.

Meissner, William. (1984). *The borderline spectrum. Differential diagnosis and developmental issues*. New York/London: Jason Aronson; New York: International Universities Press.

Searles, Harold. (1986). *My work with borderline patients*. Northvale, NJ: Aronson.

## **BOREDOM**

Boredom is a state of malaise, close to anxiety, characterized by a feeling of emptiness. Its origin is attributed to objects that the subject claims are boring, in other words, odious (*inodiosus*) in the etymological sense of the word.

Boredom (languor, neurasthenia) was one of the dark humors of ancient medicine (boredom was associated with the spleen, and melancholy, with the liver). It became the ailment of the era during the Romantic period, as typified by François-René de Chateaubriand in *René* and *The Genius of Christianity* (part 2, book 3).

Sigmund Freud did not see boredom as a specific symptom. He noted that the idleness of young women created a state of reverie dissociated from reality and susceptible to hysteria (1895d). But he saw their lassitude as normal, since other objects cannot occupy the place of the primitive lost object, the penis (1910h). Sándor Ferenczi in “Névrose du dimanche” (1919/1974) saw a link between the development of anxiety and the absence of exterior censure associated with a need to work.

With the introduction of the notion of the withdrawal of libidinal cathexis, psychoanalysis provided significant insight into the concept of boredom. Without libidinal cathexis, one loses drive and an ability to make demands, except for a need for a change associated with a miraculous arrival of an object that would again give life to one’s activities. This feeling of a loss of interest in things is, in fact, a loss of libido. Otto Fenichel assimilated boredom with a type of depersonalization in which the subject feels that he must do something but does not know what. Heinz Kohut pointed out the link between the analyst’s boredom and the feeling of exclusion that the patient provokes in him by withdrawing emotionally. Ralph Greenson saw boredom as a defense against fantasy activity or as a result of one’s unconscious perception of one’s resistance.

The analysis of boredom reveals a kind of phobic-obsessional fluctuation between withdrawal of libidinal cathexis and ardent desire driving impulsive acts that provide an outlet (Mijolla-Mellor, 1985). As with inhibition, boredom is not simply a lack of movement but a pointless stagnation, to which is added an enduring hatred of time. It is a defense against a phobic anxiety over a primary, but undifferentiated, investment in objects.

SOPHIE DE MIJOLLA-MELLOR

*See also:* Depersonalization; Decathexis; Mirror transference; Narcissistic transference; Time.

### **Bibliography**

- Fenichel, Otto. (1951). On the psychology of boredom. In *Selected papers of Fenichel*. New York: W. W. Norton.
- Ferenczi, Sándor. (1974). Difficultés techniques d'une analyse d'hystérie. *Oeuvres complètes (Psychanalyse, Vol. 3)*. Paris: Payot. (Original work published 1919)
- . (1974). Névrose des dimanches. *Oeuvres complètes (Psychanalyse, Vol. 3)*. Paris: Payot. (Original work published 1919)
- Freud, Sigmund. (1910h). A special type of choice of object made by men. *SE*, 11: 163–175.
- Freud, Sigmund, and Breuer, Josef. (1895d). Studies in hysteria. *SE*, 2: 48–106.
- Greenson, Ralph R. (1967). *The technique and practice of psychoanalysis*. New York: International Universities Press.
- Kohut, Heinz. (1974). *The analysis of the self* (M. A. Lussier, Trans.). New York: International Universities Press. (Original work published 1971)
- Mijolla-Mellor, Sophie de. (1985). La trame phobique de l'ennui. *Nouvelle revue de psychanalyse*, 32, 173–184.

### **BOREL, ADRIEN ALPHONSE ALCIDE (1886–1966)**

Adrien Borel, a French psychiatrist, was born March 19, 1886, at 80 rue Bonaparte in Paris, and died September 19, 1966, in Beaumont-lès-Valence. The only son of a doctor from the Ardèche in southern France, Borel studied in Privas and Lyon. He joined the army for three years but gave up his commission after a year. After moving to Paris to study medicine, he became an intern in 1908 and a doctor of medicine in 1913. An

auxiliary surgeon during the First World War, he was seriously wounded by a piece of shrapnel on March 1, 1915. After a brief stay in Aisnay-Le-Château, he settled in Paris.

Part of the staff of L'Évolution psychiatrique, created in 1925, he was a committed member of the Annales Médico-Psychologiques, to which he was accepted in 1923 and made a full member in 1931. It was here that he met Professor Briand, Georges Heuyer, Gilbert Robin, and others. A participant in Henri Claude's working group at Sainte-Anne's Hospital, he was one of the twelve founding members of the Société Psychanalytique de Paris (Paris Psychoanalytic Society), founded in 1926, and its president from 1932 to 1934. He participated in several meetings but made few references to psychoanalysis and none at all after the 1940s. He did not join the small group of analysts that came together in Paris during the Occupation.

He had a lengthy and important affair (until 1940) with Annette Berman, the secretary of Princess Marie Bonaparte, and it was she who became his principal point of contact with the world of psychoanalysis. Borel himself never underwent analysis and after a few sessions with several patients, including the writers Georges Bataille and Michel Leiris, who publicized his name as a therapist, he quickly abandoned analytic practice.

In 1940 he married Blanche, one of his former patients, a woman whose identity always remained ambiguous among his colleagues and friends. He never introduced her as his wife in the world he frequented and never involved her in his professional affairs.

His first research effort, his medical thesis (1913), was devoted to organic and neurological theory. He investigated several of the methods available at the time, except the psychoanalytic method, to alleviate mental suffering, which was his major concern. His last article was about lobotomy (*L'Évolution psychiatrique*, 4, 1949). He worked in several hospitals (Sainte-Anne, Bichat) and in a number of private psychiatric clinics, where he met "aesthetes," drug addicts, and individuals for whom public hospitals were out of the question.

Interested in artists and writers, painters, and "creative" individuals in general, Borel participated with René Allendy in the Groupement d'Études Philosophiques et Scientifiques pour l'Examen des Tendances Nouvelles (Philosophic and Scientific Study Group for the Examination of New Trends) in 1922. He wrote a

great deal, but much of his writing was destroyed. He published no more than a handful of pages in his own name, generally co-signing his work with other authors, primarily Claude. He wrote one work jointly with Robin, *Les Rêveurs éveillés* (Éditions Gallimard, collection “Bleue,” 1925).

An extremely gentle man, according to Bataille, cordial and corpulent, Borel’s energy often resulted in a loss of temper and disagreements with others. Protective, good-natured, and paternal, he had many points in common with the character of the Curé de Torcy, a role he played at the age of sixty-four in Robert Bresson’s film *Diary of a Country Priest*. He died September 19, 1966, of a cerebral hemorrhage at his summer home in Beaumont-lès-Valence.

NADINE MESPOULHÈS

*See also:* Berman, Anne; Claude, Henri Charles Jules; Congrès des psychanalystes de langue française des pays romans; France; Société Psychanalytique de Paris and Institut de psychanalyse de Paris; Surrealism and psychoanalysis.

### **Bibliography**

- Borel, Adrien. (1934). La pensée magique dans l’art. *Revue française de psychanalyse*, 7, 1, 66–83.
- . (1934). L’expression de l’ineffable dans les états psychopathiques. *L’Évolution psychiatrique*, 3, 35–53.
- . (1935). Les convulsionnaires et le diacre Pâris. *L’Évolution psychiatrique*, 4, 3–24.
- . (1940). La folie de Hitler est-elle celle de l’Allemagne? *Les Nouvelles littéraires*, 6, 1.

## **BORNSTEIN, BERTA (1899–1971)**

Child psychoanalyst Berta Bornstein was born in 1899 in the Austro-Hungarian city of Krakau (today Kraków, Poland), and died on September 5, 1971, in Maine in the United States.

Shortly after her birth, Bornstein’s parents settled in Berlin, where her father was an engineer. The eldest of four children, she had one sister and two brothers.

As a young educator of handicapped children (*Fürsorgerin*) in Berlin, Bornstein was just twenty years old

when she began analytic training with Hans Lampl and Edward Bibring. She participated in the child seminar directed by Otto Fenichel from 1924 to 1939 at the Berlin Psychoanalytic Institute, and by 1929 was working closely in Vienna with Anna Freud. Bornstein’s loyalty to both Fenichel and Anna Freud never wavered. She lived in Berlin, Vienna, Prague and, after leaving Europe shortly before War World II, in New York.

Bornstein brought innovative techniques to child psychoanalysis. She emphasized the precocity of children and so was able to reduce the time required to win their confidence. In her view, psychoanalysis of children ought to proceed by way of analysis of the defenses. “The introductory phase of child analysis was dropped when Berta Bornstein developed the analysis of defenses,” stated Anna Freud in 1971 (Blos, 1974, p. 36).

Bornstein pioneered a new understanding of latency. She revealed the dynamics of defense mechanisms and the progressive claims of identification and sublimation. Bornstein was opposed to the widespread view that latency is an “ideal” period during which instinctual conflicts do not exist. She suggested that latency could be divided into two stages: from five and half to eight years of age, and from eight to ten. The common factor is development of the superego as it struggles against incestuous and pregenital wishes expressed through masturbation. The first phase of latency, Bornstein believed, is favorable for psychotherapy.

Bornstein wrote only a few papers, but her clinical cases are models of technical and theoretical clarity. Bornstein’s last analytic work, concerning “Frankie,” a child of five-and-a-half years with symptoms of phobia, insomnia, and urine retention, would be validated in a follow-up analysis of the patient as an adult, conducted and presented by Samuel Ritvo in 1965. She was a widely admired teacher who taught not only at the New York Psychoanalytic Institute but also at the Menninger Clinic and Yale University. She was a member of both the New York Psychoanalytic Society and the Philadelphia Psychoanalytic Society. The name of her younger sister, Steffi, is frequently mentioned in accounts of the history of psychoanalysis; she was also a child analyst but died prematurely, in Prague, in 1939.

SIMONE VALANTIN



*See also:* Lehrinstitut der wiener psychoanalytischen Vereinigung; New York Psychoanalytic Institute; Primary identification.

### **Bibliography**

- Blos, Peter. (1974). Berta Bornstein 1899–1971. *Psychoanalytic Study of the Child*, 29, 35–38.
- Bornstein, Berta. (1935). Phobia in a two-and-a-half year old child. *Psychoanalytic Quarterly*, 4, 93–119.
- . (1945). Clinical notes on child analysis. *Psychoanalytic Study of the Child*, 1, 151–166.
- . On latency. (1951). *Psychoanalytic Study of the Child*, 6, 279–285.
- . (1953). Masturbation in the latency period. *Psychoanalytic Study of the Child*, 8, 65–78.

---

## **BOSE, GIRINDRASEKHAR (1886–1953)**

Indian psychoanalyst and physician Girindrasekhar Bose was born in 1886 and died in 1953. He was the founder of the Indian Psychoanalytic Society.

Bose, the youngest of nine children, was the son of a chief minister of a minor princely state in British India and a mother who was a poet. After finishing school, he studied chemistry in Calcutta's Presidency College and then joined the Medical College where he received his medical degree in 1910. He was married at the age of seventeen to Indumati, who bore him two daughters. He was greatly interested in yoga, magic, and hypnotism and in fact used hypnotic therapy in his medical practice during his early years and also occasionally after he became a psychoanalyst.

While practicing, as a doctor, Bose studied psychology in the newly opened department of psychology at Calcutta University. Appointed lecturer at the age of 31, after he finished his Master's degree in two years, he made psychoanalysis compulsory for all students of psychology. His doctoral thesis, *Concept of Repression* (1921) in which he blended Hindu thought with Freudian concepts and which he sent to Freud, led to a correspondence between the two men and to the formation of the Indian Psychoanalytic Society on January 22, 1922. He developed his own overly didac-

tic therapeutic technique, primarily aimed at cognitive change, which was based on his theory of "opposite wishes" (1933).

As he was the founder-president of the Indian Psychoanalytic Society and someone who conducted most of the training analyses, Bose's idiosyncratic technique came to characterize the therapeutic style of most Indian psychoanalysts. Bose's contribution, however, was less in the doubtful value of his new technique but in his emphasis on the role of culture in psychoanalysis. He did not uncritically accept the universalist premises of psychoanalysis, but engaged with Freud in a lively correspondence where he pointed out some of the cultural variations in psychoanalytic concepts, such as castration anxiety, which he had encountered in his Indian patients. His other great contribution was organizational in that he laid the foundations of psychoanalysis in India and placed the Indian Psychoanalytic Society on a sound footing through the thirty-one years of his presidency and until his death.

SUDHIR KAKAR

*See also:* India.

### **Bibliography**

- Bose, Girindrasekhar. (1933). A New Theory of Mental Life. *Indian Journal of Psychology*, 37–157.
- Hartnack, Christiane. (1990). Vishnu on Freud's Desk: Psychoanalysis in Colonial India. *Social Research*, 57 (4), 921–949.
- Indian Psychoanalytical Society. (1955). Special Issue on Bose. *Samiksa*.
- Kakar, Sudhir. (1997). Encounters of the psychological kind: Freud, Jung and India. In *Culture and Psyche: Psychoanalysis and India*. New York, Psyche Press.

---

## **BOSTON PSYCHOANALYTIC SOCIETY AND INSTITUTE**

Psychoanalysis in Boston dates from 1906, when James Jackson Putnam published the first paper in English on the treatment of hysteria by "Freud's method of psycho-analysis." In 1909, Putnam met Ernest Jones, a Welshman then living in Canada, at Morton Prince's

house, where Boston psychiatrists regularly met to discuss the current psychotherapies of suggestion. Jones was a vigorous spokesman for Freud, and with Putnam's growing enthusiasm for psychoanalysis, both men took part in the annual meeting of the American Therapeutic Society, opened by Morton Prince. Putnam spoke on Freud's discoveries about the childhood origins of adult neuroses, and Jones firmly differentiated psychoanalysis from all the psychotherapies of suggestion. He emphasized the difference between the hypnotist's domination of his subject and the analyst's use of free-association, "in almost every respect the reverse of treatment by suggestion."

This meeting marked the high point of the psychotherapy movement, welcoming psychoanalysis as if it were another form of suggestive therapy. Its importance was soon overshadowed in September 1909 by the Clark University Lectures at Worcester, Massachusetts, where G. Stanley Hall, an experimental psychologist and friend of William James, had invited many notable scientists to celebrate the twentieth anniversary of Clark. Sigmund Freud, Carl Gustav Jung, Sándor Ferenczi, Jones, and Abraham Arden Brill all attended. Brill had studied analysis in Zürich with Jung in 1908, where he met Jones, and together they had visited Freud. At Clark, Freud delivered his *Introductory Lectures*, his only address to the general public, and was invited by Putnam to visit their family camp after the meetings.

Thus Putnam developed a close friendship with Freud, reflected in their lively correspondence, and he and Jones proselytized widely for the cause of psychoanalysis. Jones persuaded him to found the American Psychoanalytic Association in 1911, and Putnam was its first president. (Shortly before, Brill had founded the New York Psychoanalytic Society.) Putnam established the first of several Boston Psychoanalytic Societies in 1914, which met weekly until his death in 1918.

Putnam's successor was Isidor Coriat, who re-established the Boston Psychoanalytic Society in 1924–1928, and again in 1930. He was the only Freudian analyst in Boston during the period after Putnam's death, leading an eclectic group of men and women analyzed by Freud, Jung, Otto Rank, and Paul Schilder.

During this era, Americans were obliged to travel abroad for analytic training, and in 1930 four newly-

trained analysts, led by Ives Hendrick, arrived in Boston from Vienna and Berlin. They sought to create an institute, modeled on the Berlin Psychoanalytic Institute, that provided full analytic training, with analyses, seminars, and supervised control-cases. The first training-analyst was Franz Alexander, who came to Boston in 1930 and returned a year later to found the Chicago Psychoanalytic Institute. In Boston, Alexander was succeeded by Hanns Sachs, a leading training-analyst from Berlin, but not a physician. This created conflicts with Hendrick's new constitution, which rejected non-M.D.s for training, and required approval by an Admissions Committee, rather than by the individual analyst. After a stormy period of reorganization, half the membership resigned, to allow ten properly analyzed members to be approved by the American Psychoanalytic Association. Boston became a constituent Society in 1933, and in 1947 a Society/Institute, called the BPSI.

The original members were mostly Americans, with a few Canadians, until the arrival of Felix and Helene Deutsch in 1935. They were part of the great intellectual migration, fleeing from Nazi domination in Germany in 1933 and Austria in 1938. Within the vast influx of refugee artists, scholars, and scientists that transformed American cultural life, the émigré analysts formed a small but influential group. They most nearly resembled the architects of the avant-garde Bauhaus and the pioneer nuclear physicists, who seemed to represent new specialties, already sought after in Boston.

The European analysts were welcomed everywhere by eager colleagues and by their former analysands. In the Boston Institute, as its membership tripled over the next ten years, the refugees soon outnumbered their native American colleagues. Unlike other American cities with refugee analysts from all of Europe, most of Boston's analysts were Viennese. This occurred because the Deutsches were friends of Jenny and Robert Waelder, the next to arrive. The Waelders obtained an academic post for Edward Bibring, accompanied by his wife Grete, and Mrs. Beata Rank joined the Deutsches' circle. Lucie Jessner was the only non-Austrian refugee who completed her analytic training there.

As the Boston Psychoanalytic Institute became Europeanized, local American institutions were influential in the distribution of analysts within the community. The pioneer analyst Clarence Oberndorf had first

noted the tendency for American analysts to hold positions in institutions. They worked in hospitals, medical schools, and schools of social work, in marked contrast to Freud's isolation from academic medicine. By 1949, ninety percent of Boston analysts held institutional posts of some kind, often working in research teams with non-analysts.

Another local tradition was Boston's unusual number of institutions devoted to children, including nineteenth-century protective agencies and the Home for Little Wanderers. The Judge Baker Guidance Center dated from 1917, and the new J. J. Putnam Children's Center from 1943, founded by Marian Putnam, the daughter of Boston's first analyst, and Beata Rank from Freud's Viennese circle. Created for the study and treatment of preschool children, the Putnam Center came to specialize in the long-term treatment of childhood autism. Child analysts were soon established in other clinics and all the university teaching hospitals. Thus Boston became an important center for training in child psychotherapy.

In two other American specialties, psychosomatic medicine and general hospital psychiatry (consultation-liaison psychiatry), Boston analysts played important parts. Stanley Cobb, chief of psychiatry at the Massachusetts General Hospital (MGH) and a founding member of the BPSI, established the first department of psychiatry in a general hospital in 1935. He taught interns and medical students how to understand their medical and surgical patients, as well as psychiatric patients, a tradition his successor Erich Lindemann continued with his medical students. Cobb welcomed refugee analysts to the MGH and invited Felix Deutsch to collaborate in psychosomatic research. Deutsch, like Franz Alexander in Chicago, expanded psychosomatic research into a major specialty, far beyond its limited scope in Vienna.

After the Second World War, there was a great increase in the demand for psychoanalytic training, partly prompted by physicians returning from military service. They had been exposed to great numbers of psychiatric casualties and taught psychoanalytic methods of treatment, like the "abreaction" therapy of Grinker and Spiegel. This demand for psychiatrists was supported by a corresponding increase in government funds for psychoanalytic training and research.

The next twenty years was a halcyon era for psychoanalysis in Boston. The Institute increased from a few

dozen members in the 1930s to over one hundred active and affiliate members in 1974 and more than two hundred by the beginning of the twenty-first century. All the chiefs of psychiatry in hospitals and medical schools were analysts, and psychiatry was a popular specialty for young physicians. For some residents psychoanalytic training was accepted as the next step in academic advancement.

The high tide in analysis began to ebb in the late 1960s, during the Vietnam War, with cuts in federal support for analytic training and research. The number of suitable patients for psychoanalysis began to dwindle, both for analysts and for candidates with supervised cases. Within the BPSI there was dissatisfaction among candidates and younger analysts, who resented the impersonality of training and the dictatorship of the Education Committee. An experiment with a deanship proved unsuccessful, and its termination by the Education Committee provoked violent protests as high-handed and autocratic.

A period of strife followed, with attempts to create a better balance between the functions of the Institute and the Society. The conflict seemed to be between traditionalists and reformers, but the crucial issue was resentment over the limited access to training-analyst status. From 1973–1974, five training analysts proposed to secede from the Institute, while retaining their membership in the Society. Their aims were vague, but they emphasized the creation of a smaller group, free from committee work and bureaucratic rules, with a more intimate atmosphere for intellectual discussion. The new Psychoanalytic Institute of New England, called PINE, was recognized by the American Psychoanalytic Association in 1991.

In spite of fears that Boston was too small for two institutes, and that the new institute would graduate many unqualified training-analysts, PINE proved successful. Both institutes have flourished, and a third Boston institute, the Massachusetts Institute of Psychoanalysis (MIP) was founded by clinical psychologists.

All institutes have faced the continuing decline in suitable patients and the recent loss of traditional psychiatric institutions, like the Massachusetts Mental Health Center. In spite of these unfavorable changes in the economic and cultural support for psychoanalysis, as well as changes in clinical psychiatry and medicine itself, the number of applicants for analytic training has diminished relatively little. The BPSI has even expanded in terms of outreach to the community,

public lectures on cultural topics, and elective courses for non-analysts on psychoanalytic psychotherapy. The viability of analytic training seems partly sustained by offering supervision in long-term psychotherapy, while dynamic teaching in medical schools has been declining. And the scientific and intellectual life of the analytic community remains lively and attractive, in contrast to the increasingly organic orientation of current clinical psychiatry, with its emphasis on drugs and the genetic etiologies of mental illness.

SANFORD GIFFORD

### **Bibliography**

- Gifford, Sanford. (1978). Psychoanalysis in Boston: Innocence and experience. In G. E. Gifford Jr. (Ed.), *Psychoanalysis, psychotherapy and the New England medical scene, 1894–1944* (pp. 325–345). New York: Science History Publications.
- Grinker, R. R., and Spiegel, J. P. (1934). *War neuroses in North Africa, the Tunisian campaign September–May 1943*. New York: Josiah Macy Jr. Foundation.
- Hale, Nathan G. Jr. (1971). *Freud and the Americans: The beginnings of psychoanalysis in the United States, 1876–1917*. New York: Oxford University Press.
- . (1971). *James Jackson Putnam and psychoanalysis*. Cambridge: Harvard University Press.
- Rosenzweig, Saul. (1992). *The historic expedition to America 1909: Freud, Jung and Hall the king-maker*. St. Louis, MO: Rana House.

## **BOUNDARY VIOLATIONS**

*Boundary violations* in psychoanalysis refer to the egregious and potentially harmful transgressions of the analytic frame that represent exploitation of the patient's vulnerable position.

While the most widely discussed boundary violation is sexual relations between the analyst and the patient, nonsexual boundary violations are common as well. These may include such phenomena as soliciting donations from one's patient, entering into a business transaction with one's patient, excessive self-disclosure of the analyst's personal problems, and breaking the patient's confidentiality.

Maintaining professional boundaries should not be construed as a call for rigidity. Indeed, a flexible analytic frame is necessary to respond to patients with

varying needs, conflicts, and deficits. The elasticity of the frame reflects not only the patient's specific needs, of course, but also the analyst's subjectivity. Moreover, there are situations in which a break of the frame may be a helpful departure from the usual boundaries. Gutheil and Gabbard have referred to these instances as *boundary crossings* rather than violations.

In addition, counter-transference enactments are inevitable to some extent, and the differentiation between a useful enactment and a boundary violation is sometimes ambiguous. A useful enactment generally involves an analyst who has caught himself or herself in the midst of the enactment before it escalates to the point of becoming a serious violation. Also, the capacity of both patient and analyst to analyze the incident may determine whether a particular behavior is destructive or productive. Finally, enactments that are repetitive and unresponsive to the analyst's own self-analytic efforts are more likely to be harmful than those that are subjected to self-analytic scrutiny and prevented from recurring.

The concept of boundary violations is a relatively recent addition to the psychoanalytic literature, although the early history of psychoanalysis was replete with such violations. While Sándor Ferenczi was analyzing Elma Palos, he professed his love for her and ultimately referred her to Freud for analysis. Ernest Jones's common-law wife, Loë Kann, was a former patient of his. Margaret Mahler acknowledged in her memoirs that she had been sexually involved with her analyst, August Aichhorn. Many of these instances were ignored; if they did come to light within psychoanalytic institutes, the solution was often to send the analyst back for more analysis rather than to take any form of disciplinary action.

With the rise of the women's movement, female patients became more assertive in expressing their sense of having been exploited by male analysts (cases of sexual boundary violations most commonly involve a male analyst and a female patient), and some form of reparation was often demanded.

Gutheil and Gabbard first attempted to delineate the concept of boundary violation and boundary crossings in a 1993 article. Subsequently, Gabbard and Lester argued that preservation of professional boundaries not only protects the patient from harm, but also serves to create "the analytic object," which is an amalgam of the transference object and the new object jointly created by the subjectivities of analyst and patient.

Critics of the new emphasis on boundary violations have expressed concern that such limits may constrict

the spontaneity of the analyst. Rigidity might prevent the analyst from engaging the patient. Attention to boundaries, however, does not promote coldness or rigidity in the analytic relationship. The intent is exactly the opposite. Professional boundaries define the parameters of the analytic relationship so that the patient can interact in an atmosphere of safety that includes an analyst who can be warm and spontaneous.

Another concern expressed about the concept of professional boundaries is that sexual boundary violations are committed by predatory analysts with severe psychopathy or antisocial personality disorders. Other analysts, the argument goes, need not concern themselves with boundaries because they are essentially ethical. Systematic studies of analysts who have had sexual and nonsexual boundary violations with patients, however, suggest that many who have otherwise been ethical and honest may be susceptible to falling in love with the patient and transgressing boundaries at a time in their lives when they are under great personal stress. Hence there is a strong argument for teaching constructs like professional boundaries and boundary violations to all analysts.

GLEN O. GABBARD

*See also:* Abstinence/rule of abstinence; *Collected Papers on Schizophrenia and Related Subjects*; Counter-transference; Dependence; Psychoanalytic treatment; Transference love; Transgression.

### **Bibliography**

- Gabbard, Glen O. (1995). The early history of boundary violations in psychoanalysis. *Journal of the American Psychoanalytical Association*, 43, 1115–1136.
- Gabbard, Glen O., and Lester, Eva. (1995). *Boundaries and boundary violations in psychoanalysis*. New York: Basic Books.
- Gutheil, Thomas G., and O. Gabbard, Glen O. (1993). The concept of boundaries in clinical practice: Theoretical and risk-management dimensions. *American Journal of Psychiatry*, 150, 188–196.

---

## **BOUVET, MAURICE CHARLES MARIE GERMAIN (1911–1960)**

A French psychoanalyst, Maurice Charles Marie Germain Bouvet was born August 14, 1911, in Eu (Seine-

Maritime) and died on May 5, 1960, in Paris. His father, a graduate of the École Polytechnique and a career officer, married while he was stationed in Clermont-Ferrand. It was here that Bouvet completed his secondary education and his medical studies. He did his internship between 1931 and 1932.

After arriving in Paris he was appointed a resident in 1936, a doctor at a psychiatric clinic in 1939, and made head of clinical services under Professor Laignel-Lavastine in 1940. In 1942 he served as doctor and interim director of the psychiatric hospital in Moisselles and was transferred to a hospital in Clermont in the Oise region of France from 1943 to 1945.

Because of his fragile health, Bouvet began to experience problems with his vision by 1940, which resulted in near blindness. During the Occupation he began a teaching analysis with Georges Parcheminey, soon followed by supervised analyses with John Leuba and Sacha Nacht. He became a member of the Paris Psychoanalytic Society in 1946 and was made a member on November 16, 1948. For a number of years Bouvet served as treasurer and vice president, before becoming president in 1956. During the period prior to the 1953 split in the society, Bouvet felt that liberalization of the organization was needed. However, possibly because of the analysis he was conducting with Daniel Lagache, Bouvet decided to remain neutral. He subsequently decided to remain within the society, primarily because of his medical background.

His publications had attracted notice as early as 1948. In November 1952, he was reporter for the XV Conférence des Psychanalystes de Langues Romanes, whose topic was “The Ego in Obsessive Neurosis: Object Relations and Defense Mechanisms.” In 1954 he published “La cure-type” (The standard cure) in the *Encyclopédie médico-chirurgicale*, there describing the distinction between “transference resistance” and “resistance to transference.” In that same article Bouvet expressed his fidelity to Freud, indicating that interpretation must adhere closely to the behavior of the ego. The following year Jacques Lacan’s article “Les variantes de la cure” (Different forms of therapy) seemed to supply a rebuttal to Bouvet, the only theoretician in the Paris Psychoanalytic Society who could take advantage of his growing reputation. He returned to the problems of therapy during the Twentieth International Psychoanalytic Congress, which took place in Paris in July 1957, with a report on “Les variations de la technique (Distance et

variations)” [Variations in technique: Distance and variations].

Lacan maintained his critical stance while Bouvet promoted “object relations” in 1952 and completed his study of the subject in “La clinique psychanalytique. La relation d’objet” (Clinical practice in psychoanalysis: Object relations), published in *La Psychanalyse aujourd’hui* (1959). For Bouvet the object relation represents “a flow of drive energy, a movement controlled and directed by the ego toward external objects.” He described the various aspects of object relations and their pathological states, such as phobias, obsessions, psychoses, and perversions, emphasizing the regression to oral or anal object relations in “pregenital” subjects with “weak” egos. He established a “distance relation” between the subject and its objects, which becomes greater as these are transformed by projection.

Bouvet studied these mechanisms in detail, especially in the context of obsessive neurosis, and described the states of depersonalization that occur whenever the patient is unable to defend himself through isolation because of the uncontrollable violence of his affects and the predominant anal-sadistic projection that characterizes such patients. This was the theme of the XXI Congrès des Psychanalystes de Langues Romanes in April 1960: “Dépersonnalisation et relation d’objet.” Unfortunately the decline in his health prevented Bouvet from presenting the article, which was read by Pierre Marty. Afflicted with malignant hypertension and respiratory failure, he died on May 5, at the age of forty-nine.

The analyst of André Green, Michel de M’Uzan, François Perrier—and even, for a short while, of Maryse Choisy—he was remembered through the creation of the Prix Maurice Bouvet in 1962; his publications were collected and published in 1968. As Michel de M’Uzan wrote in his introduction, “For many Michel Bouvet was a master, but a discreet master, who was as demanding in the affirmation of his knowledge as he was in his sense of freedom. Nothing demonstrates this better than the way his ideas were transmitted.”

Although he is not widely remembered today and his concepts of the object relation and standard cure have assumed negative and outmoded connotations in France (unlike the United States), he remains a key figure in the theoretical and clinical fields he investigated throughout his life.

ALAIN DE MIJOLLA

*See also:* Congrès des psychanalystes de langue française des pays romans ; Depersonalization; Object; Psychoanalytic treatment; Société psychanalytique de Paris and Institut de psychanalyse de Paris.

### Bibliography

- Bouvet, Maurice. (1968). *Œuvres psychanalytiques, 2, Résistances, transfert*. Paris: Payot.
- Green, André. (1960). L’œuvre de Maurice Bouvet. *Revue française de psychanalyse*, 24 (6), 685–702.
- Hommage à Maurice Bouvet. (1960). *Revue française de psychanalyse*, 24 (6), 675–720.
- Sauguet, Henri. (1960). La carrière de Maurice Bouvet. *Revue française de psychanalyse*, 24 (6), 679–683.

---

## BOWLBY, EDWARD JOHN MOSTYN (1907–1990)

An English psychiatrist and psychoanalyst, Edward John Bowlby was born February 26, 1907, in London and died September 2, 1990, in Skye Ball, Great Britain. His childhood was divided between an urban life in London, where he was raised by nannies, and vacations in the countryside with his family. In 1938 he married Ursula Hongstaffs, a musician, with whom he had four children. He began his medical studies in 1929 in London and entered into analysis with Joan Rivière. He worked as a psychiatrist at the London Child Guidance Clinic until the war, when he joined the army. After the war Bowlby joined the Tavistock Clinic, where he served as director of the children’s center from 1950 to 1972. As Donald Winnicott’s secretary at the British Psychoanalytical Society from 1956 to 1961, he organized training sessions and research activities. From 1950 to 1972 he was a mental health consultant for the World Health Organization. In 1980 he was named professor of psychoanalysis at University College in London.

Bowlby studied psychoanalysis in order to become a child psychoanalyst. His first supervised psychoanalysis with Melanie Klein in 1937 soon revealed a fundamental difference between them: For Bowlby the environment and its role were not sufficiently accounted for in Klein’s theories. Based on his highly original clinical training (he worked with handicapped and institutionalized children) and his sensitivity to the function of the

mother-child bond and the environment, he developed the position that the instinct for preservation is as important as that of sexuality and that the mother-child bond is independent of infantile sexuality.

His admission to the British Psychoanalytical Society, which was then (in 1940) torn by the struggles between Kleinians and supporters of Anna Freud, is important. Bowlby acknowledged his connection to Anna Freud while regretting her refusal to accept the reality of trauma. In 1958, for the appearance of his article "The Nature of the Child's Tie to his Mother," Bowlby proposed a revision of metapsychology: abandonment of the theory of anaclysis, abandonment of the economic point of view, emphasis on the dynamic point of view, and definition of the unconscious as the interiorization of interpersonal experiences. He was criticized and rejected by the Psychoanalytical Society with unusual severity. Deeply wounded by the reaction of his peers, he gradually withdrew from the Society, and turned to other scientific activities then in vogue (ethology, cybernetics, and systems theory). He worked for more than twenty years on his book on attachment. It was only after 1981 that he was asked to return to analysis and develop the clinical and psychotherapeutic implications of his theory.

Bowlby's work had a tremendous impact on public health especially, in providing a better understanding of the effects of separation on young children, and the prevention of these effects. He also made numerous contributions to social science: contributions to developmental psychology and psychiatry, especially the roles of security, reciprocity, intersubjectivity, and the interpersonal development of thought in the young child; contributions to the understanding and management of borderline states; theorization of so-called non-specific factors in psychotherapy, and treatment of so-called "inaccessible" families subject to multiple risks.

NICOLE GUÉDENEY

*See also:* Abandonment; Aphansis; Attachment; Great Britain; Maternal care; Primary need; *Psychoanalytic Study of the Child, The*; Schur, Max; Stranger; Tavistock Clinic; Tenderness.

### **Bibliography**

Bowlby, John. (1944). Forty-four juvenile thieves: Their characters and home life. *International Journal of Psycho-Analysis*, 25, 1–57; 207–228.

———. (1951). *Maternal care and mental health*. Geneva: World Health Organization Monographs.

———. (1969). *Attachment and loss* (Vol. 1). London: Hogarth Press.

Eagle, Morris. (1995). The developmental perspectives of attachment and psychoanalytic theory. In S. Goldberg, R. Muir, J. Kerr (Eds.), *Attachment theory. Social, developmental and clinical perspectives* (pp. 123–153). Hillsdale, NJ-London: The Analytic Press.

Holmes, Jeremy. (1993). *John Bowlby and attachment theory*. London: Routledge.

---

## **BRAIN AND PSYCHOANALYSIS, THE**

The effort to establish the relationships between psychological functioning, the organization of the apparatus that implements it, and the working and structure of the brain, is an issue that has been raised continually since the beginnings of psychoanalysis. Psychic activity that arises wholly independent of the brain itself is inconceivable. The question is whether we can identify specific cerebral mechanisms and structures that could be said to govern those characteristics of mental functioning that psychoanalysis has discovered.

This means viewing psychoanalysis in the context of a much more general problem, that of the relationship and interaction between mind and brain. Freud was confronted with this question long before he developed an interest in psychopathology and the psychotherapy of hysteria. His work on aphasia (1891b) is part of what has been rightly described as a neuropsychological tradition (Pribram and Gill).

In the early 1890s, thanks to the anatomicopathological methods introduced by Paul Broca, it was shown that the function of language resulted from independent mechanisms that could be altered in isolation and that such specific alterations were tied to relatively localized lesions. This work, especially that of Carl Wernicke, confirmed the existence of cerebral localizations and the "modular" nature of the mechanisms involved in the exercise of particular functions. Freud, anticipating the findings of much later neuropsychology, went on to criticize the exaggeratedly modular approach involved in this conception of the brain and proposed a more comprehensive and functionalist view of cerebral activity according to which the "centers" identified would participate in carrying out their respective functions.

In 1895, in what is known as his “Project for a Scientific Psychology,” a work that remained unfinished and was later abandoned, and which was to have been titled “Psychology for Neurologists,” Freud proposed a structural and functional model based on the recently recognized concept of the neurone to describe brain functions in relation to mental activity. Like many others at the time (Gauchet), he was careful to conceive of mental activity independently of consciousness, and attempted to base his picture of psychic functioning on the model of the brain. That picture already bore the imprint of Freud’s own metapsychology, especially with respect to the assimilation of consciousness to an internal perception, the dissociation between perception and memory traces, the priority of “hallucinatory” representation over reality, and in other facets.

Freud soon abandoned any pretensions to constructing a model of the brain likely to account for the features of mental life revealed by psychoanalysis. This abandonment was strictly methodological, however, and throughout his work he firmly maintained the idea that brain mechanisms must ultimately determine these features. On several occasions, in fact, he risked drawing parallels between cerebral and metapsychological models.

Subsequently, and especially during the last four decades of the twentieth century, the considerable progress made in understanding the brain has not failed to invite speculation among psychoanalysts. Hemispheric laterality, cortical-subcortical dissociation, individualization of the limbic circuit, experiments with self-stimulation leading to the isolation of structures of positive and negative reinforcement (pleasure–unpleasure), humoral transmission systems, and so on, have resulted in research and the construction of models involving a distinct parallelism.

This immediately raises several questions. No one contests the need to postulate the existence of cerebral mechanisms, but does it follow that we need them to identify the symbolic structures (language, social structures, etc.) that influence mental development? Clearly every particular aspect of mental life can be explained by some form of psychological determinism, but what can be said about the functions of dreaming, in particular its function as a guardian of sleep? Will we ever establish any strict isomorphism between brain functions and mental functions? All such questions are still open.

More generally, a distinction may usefully be drawn between those who believe that the psychoanalytic

conception of mental life can help us understand the workings of the brain and those who feel that this understanding must involve reducing the complexity of observed mental activities to elementary cognitive mechanisms. This debate affects psychoanalysts and philosophers as well as specialists in brain physiology.

DANIEL WIDLÖCHER

*See also:* Hard science and psychoanalysis.

### **Bibliography**

Freud, Sigmund. (1891b [1953]). *On aphasia (a critical study)* (E. Stengel, Trans.). New York: International Universities Press.

———. (1950c [1895]). Project for a scientific psychology. *SE*, 1: 281–387.

Gauchet, Marcel. (1992). *L’Inconscient cérébral*. Paris: Le Seuil.

Pribram, Karl H., and Gill, Merton M. (1976). *Freud’s “project” reassessed*. London: Hutchinson.

---

## **BRAZIL**

Psychoanalysis aroused strong resistance when it first appeared in Brazil, provoking different reactions in different milieux. Salvador-born Julian Moreira (1873–1933) was the first to speak of Freud, in 1899. In 1903 he was appointed director of the national hospital for the insane in Rio de Janeiro, where he settled for the rest of his life. An innovative psychiatrist with an international reputation, he invited his disciples and collaborators to study psychoanalytic ideas. In 1914 Jenserico Aragão de Souza Pinto published “On Psychoanalysis. Sexuality in the Neuroses.” Two conferences in 1919 awoke the interest of future psychoanalysts: Franco da Rocha’s “On delusion in general” (at São Paulo) and “Psychology of a neurologist—Freud and his sexual theories” by Medeiros e Albuquerque in Rio de Janeiro.

In the 1920s, physicians in São Paulo and Rio sometimes criticized psychoanalysis in a Manichean fashion: on the one hand it was labeled charlatanesque while being enthusiastically hailed on the other. It must also be said that psychoanalytic ideas arrived at a time of great effervescence that saw the publication of “modernist” literary reviews and the *Semana de Arte Moderna* in 1922. Influenced by the European



avant-garde, this atmosphere facilitated the acceptance of psychoanalytic ideas in São Paulo.

It was there that Durval Marcondes published several articles and Osorio Cesar wrote about the artistic productions of the mentally ill. Among Juliano Moreira's disciples in Rio, Antonio Austregesilo produced somewhat superficial work but others, such as Neves Manta, Carneiro Ayrosa, and Murilo de Campos, were doing more important work, and Deodato de Moraes was busy producing his excellent book *A psicanálise na Educacao* (1927), while J. P. Porto-Carrero continued to work on many books and articles.

Again in Rio but outside Moreira's entourage, Henrique Roxo was quoting Freud as early as 1905 but he proved to be very organicistic in his views. During the 1930s Aloysio de Paula wrote on applied psychoanalysis and Gastão Pereira da Silva, a physician and journalist, contributed to propagating psychoanalytic ideas. Mauricio de Medeiros, who occupied the chair of psychiatry in the 1950s institution, supported the psychoanalytic approach.

Although born at Alagoas, Arthur Ramos, physician and psychiatrist, was considered to be a citizen of Bahia. His thesis *Primitivo e locura* (1925) was widely commented on and, between 1930 and 1932, he studied Freud's work with a small group. He settled in Rio in 1934. A professor of anthropology and ethnography, he became a renowned specialist on Africa and wrote some psychoanalytic works. At Porto Alegre in 1924, João Cesar de Castro wrote *Concepcao Freudiana das Psiconeuroses* and in France Martim Gomes published *Les Rêves* (1928). Ulisses Pernambucan came under the influence of Juliano Moreira while studying medicine in Rio. He went on to become a pioneer of social psychiatry in Brazil and considered psychoanalysis as the subtlest means of penetrating the human mind.

In 1927 Marcondes founded the first Sociedade brasileira de psicanálise in São Paulo. Although it had no training section it was nevertheless recognized by the International Psychoanalytic Association with a view to propagating Freud's ideas. In 1928 Marcondes gave his blessing to the setting up of a subsidiary branch in Rio (V. Rocha, Marcondes, and Porto-Carrero).

Thanks to Marcondes's persistent pressure on Ernest Jones, the Jewish German psychoanalyst Adelheid L. Koch, who had been analyzed by Otto Fenichel,

emigrated to São Paulo with her husband in 1936, and in 1937 began to analyze Durval Marcondes, Darcy Mendonça Uchôa, Virginia Bicudo, Flavio Dias, and Frank Philips, soon to be joined by three more patients. Because she was the only qualified analyst, she singlehandedly conducted analyses, gave seminars and acted as supervisor. The first São Paulo Grupo psicanalítico, which she founded in 1944 with her first analysands, was provisionally accepted in 1945 as the Sociedade brasileira de psicanálise de São Paulo (SBPSP). It received definitive recognition at the Amsterdam Congress (1951).

The early days in Rio de Janeiro were not so easy. Dissatisfied with the official teaching of psychiatry, a group of young physicians founded the Centro de estudos Julian Moreira in 1944 and envisaged two possible hypotheses for the formation of a future psychoanalytic group: either to invite training analysts or seek training elsewhere. Intense correspondence with foreign analysts bore no fruit. Thus, from 1945 to 1947, Alcyon Baer Bahia, Danilo Perestrello, Marialzira Perestrello, and Walderedo Ismael de Oliveira began training at the Asociación Psicoanalítica Argentina (APA) with analysts who had qualified in Berlin, Paris, Vienna, and Buenos Aires.

In 1947 the Instituto brasileiro de psicanálise was founded in Rio in order to facilitate the legal arrival of foreign analysts. Mark Burke, analyzed by James Strachey and a member of the British Psycho-Analytic Society (BPS), arrived in February 1948. He was followed in December 1948 by Werner Kemper, a German psychoanalyst analyzed by Carl Müller-Braunschweig and who had worked during World War II in the Göring Institute before joining the DPG (Deutsche Psychoanalytische Gesellschaft). They both commenced training analyses almost immediately. In the beginning Burke and Kemper worked in collaboration with each other but in 1951 they separated amidst serious mutual reproaches. Kemper was expelled from the institute and, along with his analysands, founded the Centro de estudos psicanalíticos.

The four physicians who had gone to Buenos Aires returned between 1949 and 1950, both Perestrello and Walderedo having become associate members of the APA. Three groups were then formed: "the Argentinians," Burke's group, and Kemper's group. The "Argentine" group formed no alliances with either of the other two. When Burke suddenly left Brazil before his group had completed their training, three of his

students left for London and the others completed their supervisions at São Paulo.

During the 1953 international conference in London, Kemper's group was recognized as a study group under the sponsorship of the SBPSP, and as the Sociedade psicanalítica do Rio de Janeiro (SPRJ) at the 1955 international conference in Geneva. Its founders included seven full members (Werner Kemper, Katrin Kemper, Fabio Leite Lobo, Gerson Borsoi, Inaura Carneiro Leão Vetter, Luiz Guimarães Dahlheim, Noemy Rudolfer) and four associate members.

Three Brazilians arrived from London in 1954 and 1956 (two of them as associate members of the BPS). They became known as "the English." After a series of agreements and disagreements, the "Argentineans," the "English," and the "Burkians" finally accepted the sponsorship of São Paulo and were recognized as study groups at the Paris congress in 1957. The founders were the full members A. A. Bahia, D. Perestrello, and Walderedo I. de Oliveira (of the APA) and Henrique Mendes (SBPSP), with, as associate members, Decio Sobres de Souza and Edgar Guimarães de Almeida (of the BPS), M. Perestrello (APA), Mario Pacheco de Almeida Prado (SBPSP), and three physicians who were finishing their training at São Paulo.

At the Copenhagen congress in 1959, the group was recognized as the Sociedade brasileira de psicanálise do Rio de Janeiro (SBPRJ), with fourteen founders from different backgrounds: the eight previously mentioned, along with Luiz L. Werneck, João Côrtes de Barros, and Pedro Ferreira (already qualified with the SBPSP), M. T. Lyra (associate member of the BPS), Inaura Carneiro Leão Vetter and Zenaira Aranha (SPRJ), analyzed by Kemper. In Rio Grande do Sul, Mario Martins, Zaira Martins (1945), and José Lemmertz (1947) began their analytic training with the APA. The Martins couple returned in 1947 and Lemmertz in 1949. They qualified a few years later.

During the Edinburgh congress in 1961, the Porto Alegre study group was accepted under the sponsorship of the SPRJ. And the Sociedade Psicanalítica de Porto Alegre (SPPA) was recognized at the Stockholm conference in 1963 with, as founders, the three previously mentioned members, along with Cyro Martins (APA), Celestino Prunes, and Ernesto La Porta (SPRJ), together with José Maria Santiago Wagner (already in training at Porto Alegre). In 1946 Iracy Doyle Ferreira left for the United States and trained at the William Alanson Institute of Psychiatry (WAIP). Upon return-

ing she spread the contributions of Harry Stack Sullivan, Erich Fromm, Karen Horney, and Abram Kardiner. Around 1950 she started several training analyses and, in 1952, founded the Instituto de Medicina Psicológica (IMP), which received WAIP authorization in 1953.

On May 6, 1967, the Associação Brasileira de Psicanálise (ABP) was founded with a view to uniting the four societies recognized by the IPA in order to foster and provide assistance for future core and study groups and to publish a joint review. In 1975 the ABP created the Recife psychoanalytic core group and the Pelotas core group in 1987. Having met all the requirements of the IPA, these two groups were admitted as study groups. The Sociedade Psicanalítica de Recife and the Sociedade Psicanalítica de Pelotas became provisional study groups at the San Francisco congress in 1995. Three new study groups were recognized: the Porto Alegre group in 1992, the Ribeirão Preto group in 1993, and the Brasília group in 1994. During the Barcelona congress in 1997, the first of these groups was admitted as the Sociedade brasileira de Psicanálise de Porto Alegre. In 2005 four other core groups, located at Belo Horizonte, Campo Grande, Curitiba, and Espírito Santo were working with a view to being recognized as study groups.

Durval Marcondes, Mario Martins, and Danilo Perestrello were posthumously named honorary presidents of the ABP.

The military dictatorship (1964 to 1985) affected not only political life but also, in a direct and particularly harsh manner, the cultural life of the country. Ideas were suppressed and censorship was openly practiced in university, literary, artistic, and scientific circles, as witnessed by the events at the famous Instituto Oswaldo Cruz. The atrocities committed by groups and individuals in the name of "Institutional Acts" are known throughout the world. The psychoanalytic milieu also suffered an unhealthy influence. Although some candidates and analysts took an active part in the struggle for the redemocratization of the country, others proved to be full of anti-communist prejudice. However, some of these same colleagues, while being politically to the right, maintained a psychoanalytic position in their consulting rooms without blindly submitting to their political ideology.

In 1973 the clandestine newspaper *Voz Operária* denounced Amilcar Lobo Moreira da Silva, a candidate for the SPRJ (Rio I), as a member of the military

police's torture squad. An analyst from the other Rio society, SBPRJ (Rio II), Helena Besserman Vianna, sent the press cutting to Argentina, where it was published in the review *Questionamos*, directed by Maria Langer. The denouncement was communicated to the IPA and other psychoanalytic societies, along with the name of the candidate and his analyst, Leáo Cabernite.

This courageous denouncement was not taken seriously by Serge Lebovici, president of the IPA, or by David Zimmermann, president of the Coordinating Committee for Psychoanalytic Organizations in Latin America (COPAL), nor was it credited by the managing council for Rio I, with Leáo Cabernite as its president. It was considered to be a "rumor" and "calumny" against Amilcar Lobo. A persecution campaign was started against the person who made the denunciation (who suffered the consequences in her society) and not against its subject.

An IPA committee visiting Rio came to no firm conclusion, but in October 1980 Amilcar Lobo was definitively excluded from the SPRJ as a trainee candidate. In 1981 ex-prisoners identified Amilcar Lobo before the Commission for the Rights of Man of the Brazilian Bar Association. When questioned, the ex-prisoners provided the following statements: "Lobo did not torture people directly but he supervised prisoners' health to determine whether they could continue to be tortured or not." Sometimes "Lobo acted in two stages: firstly he evaluated vital data and checked their capacity to resist torture, then he administered medicines intravenously in order to make it easier to acquire information." In 1986 a group of prisoners appeared at an assembly of the SPRJ to confirm these accusations. In 1988, when Lobo's guilt had been proven, the regional medical council struck him off the register of physicians. The federal council later amended the suspension to thirty days. Informed of this situation, the IPA wrote to the SPRJ stating the necessity of expelling Cabernite. Cabernite had resigned not long before in "disgust" at the IPA's attitude and now asked to be reinstated. In the course of an assembly in 1993 he was reinstated by vote. Disturbed by this resolution, which they considered to be contrary to the statutes, the president of Rio I, Claudio de Campos, and his colleagues in the managing council resigned from their positions. An ethics commission was formed to study the Cabernite case. After a two-year study, a long report recommended expelling Cabernite from the society and suspending another

incriminated member, La Porta, for one year. At the end of 1995 an assembly of Rio I discussed the report and refused to accept the recommendations of the ethics commission. Six members resigned immediately. This was followed by a controversial debate, many members of the SPRJ being unable to accept this "lack of respect" for the study and efforts of the ethics commission. To highlight their difference from the leadership of Rio I without however resigning from it, they founded the Grupo Pró-Etica and published a small journal, *Destacamento*.

Other societies manifested their discontent when Cabernite was granted an amnesty, speaking of a possible sanction for the SPRJ. For several years the executive council of the IPA had not considered the Besserman-Lobo-Cabernite problem in an impartial fashion. In 1995, however, during the presidency of Horacio Etchegoyen, the executive committee rehabilitated Helena Besserman Vianna and in 1997 appointed an ad hoc investigating commission consisting of members from Europe and North and South America to study all the documents and present a report that would be available to all IPA members at Barcelona. Having heard all parties in the dispute, the executive council was to elucidate the problem in an objective manner.

In March, 1997, Cabernite resigned definitively from the SPRJ. The report considered him guilty of unethical and morally reprehensible conduct and concluded that he could not be admitted under any circumstances into any IPA-affiliated psychoanalytic society. During the Barcelona congress in July 1997, the executive council unanimously accepted and ratified the ad hoc commission's report.

Psychoanalytic ideas were first introduced at a university level by Marcondes, Bicudo, Danilo Perestrello, and Oliveira, and later by Mendonça Uchôa, Renato Mezzan, Portella Nunes, Prunes, P. Guedes, and Zimmermann. Medical (non-psychiatric) circles were pervaded with a dynamically charged atmosphere under the influence of Danilo Perestrello, Gernandes Pontes, Miller de Paiva, and Capizano, who inculcated psychosomatic concepts and accorded great importance to the physician-patient relationship, with the help of Mario and Cyro Martins, J. Mello Filho, A. Eksterman, and others. With regard to the relationship between psychoanalysis and the arts, literature, and mythology, it is essential to mention the contributions of Bahia, Cyro Martins, Meneghini, Hermann, Marialzira

Perestrello, Nosek, Oliveira, Honigsztejn, David Azoubel, and many more. Nise da Silveira conducted research into the artistic production of mental patients and created the “Museu do Inconsciente.” Some articles by these authors have become known abroad.

In 1928 Marcondes published the first and only issue of *Revista brasileira de psicanálise*, although the review reappeared in 1967 with the BPA. The SBPSP publishes the IDE review and its Institute publishes the *Jornal de psicanálise*. For two years the two Rio societies published the *Revista de psicanálise do Rio de Janeiro*. The SBPSP publishes *TRIEB* and the SPPA publishes the *Revista de psicanálise de Porto Alegre*.

It must be said that the country has other societies in addition to those affiliated with the IPA. The short-lived Sociedade de psicologia individual (Adlerian) was founded in the 1930s. In 1994, during the presidency of Horus Vital Brazil, the IMP took on the name Sociedade psicanalítica Iracy Doyle and was affiliated with the International Federation of Psychoanalytical Societies (IFPS). It publishes *Tempo psicanalítico* and *Cadernos do Tempo psicanalítico*. The Sociedade brasileira de psicoterapia de grupo was founded in December 1958 with twenty-six members and Walderedo de Oliveira as president. Following the foundation of the Associação brasileira de psicoterapia analítica de grupo, the affiliated societies changed their name to “Analytic group psychotherapy.” The Rio de Janeiro society is currently called GRADIVA. The *Círculo brasileiro de psicanálise*, founded in 1956 in southern Brazil, is affiliated to the IFPS and comprises about ten sections scattered over several cities. The Recife society publishes two reviews: *Revista psicanalítica* and *Cadernos de psicanálise*. In 1963, in Belo Horizonte, Father Malomar Lund Edelweiss founded the *Círculo psicanalítico de psicologia profunda* (Igor Caruso), affiliated with the IFPS, which in turn led to the founding of other societies.

Because the two Rio IPA-affiliated societies refused to accept non-physicians, a group of nine psychologists founded the Sociedade de psicologia clínica in Rio in 1971 with Maria Regina Domingues de Moraes as president. In 1989 it changed its name to Sociedade de psicanálise da cidade and published *Foco* and *Cadernos de psicanálise*. In 1967 Werner Kemper returned to Germany leaving his wife Kattrin and two sons in Brazil. In 1968 she left the SPRJ, followed by several of her analysands. In 1969 four of them along with four people linked to Father Malomar founded

the *Círculo psicanalítico do Rio de Janeiro* (affiliated to the IFPS), which Kattrin Kemper joined in 1972.

In São Paulo the Sedes Sapientiae, founded in the 1970s, took an active interest in social problems, organized specialist courses, a psychoanalysis department from 1985, and published *Percurso*. With a Jungian orientation, the Sociedade brasileira de psicologia analítica (founded in São Paulo in 1975) and the Associação jungiana brasileira operate in São Paulo and Rio. They are both affiliated with the International Association for Analytic Psychology.

There are many Lacanian societies. The Campo freudiano was dissolved after operating for fifteen years and, spurred on by Jacques-Alain Miller, eleven founders created the Escola Brasileira de Psicanálise do campo freudiano (EBP) in Rio de Janeiro in June 1995. The EBP is a member of the World Association of Psychoanalysis and numbers five sections and three secretariats. It would be impossible to mention all the societies and groups in the different schools: It is currently essential to maintain a certain pluralism in terms of ideas.

Following the IFPS 1989 congress, a Forum brasileiro de psicanálise was opened up to all societies with a view to reconciling different theories. Emilio Rodríguez, a former full member of the APA, has lived at Salvador (Bahia) for more than twenty years. Without belonging to any society, he is respected for his profound humanistic culture and his independent spirit.

Freud’s work has been and still continues to be the basic subject of study in the majority of Brazilian societies. As early as 1950, Kleinian ideas enjoyed great popularity in Rio and São Paulo, thanks to Decio de Souza, V. Bicudo, Philips, and Lyra, and thanks to the couple Mario and Zaira Martins at Porto Alegre. Some Rio and São Paulo analysts underwent a second analysis and attended seminars and supervisions at the British Society. Several Kleinians visited Brazil. For several years the founders and members of societies not affiliated to the IPA attended courses by Arminda Aberastury and Mauricio Knobel. Sándor Ferenczi, Karl Abraham, Wilhelm Reich, and William Fairbairn were studied in turn. Donald Winnicott has been taught since 1970. Bahia and Philips, and then León Grinberg, introduced Wilfred Bion in the 1970s, and his theories continue to receive widespread dissemination. Heinz Kohut’s self psychology has been taught since 1980. Many societies not affiliated to the IPA conduct in-depth

studies of Lacanian thought, which was not introduced in IPA societies until the end of the twentieth century. The different schools are involved in disputing the right to dispense training in a more democratic manner than formerly.

MARIALZIRA PERESTRELLO

### **Bibliography**

- Besserman-Vianna, Helena. (1997). *Politique de la psychanalyse face à la dictature et à la torture. N'en parlez à personne*. Paris: L'Harmattan.
- Galvão, Luis Almeida Prado. (1967). "Notas para a história de psicanálise em São Paulo." In *Revista brasileira psicanalítica*, 1 (1), 46–68.
- Perestrello, Marialzira. (1992). Histoire de la psychanalyse au Brésil des origines à 1937. *Frénésie*, 2 (10), 283–304.
- . (1992). *A Psicanálise no Brasil. Encontros: psicanálise*. Rio de Janeiro: Imago.
- Perestrello, Marialzira, et al. (1986). *História da Sociedade brasileira de psicanálise do Rio de Janeiro: suas origens e fundação*. Rio de Janeiro: Imago.
- Sagawa, Roberto Yutaka. (1980). Durval Marcondes e o início do movimento psicanalítico brasileiro. *Cadernos Freud-Lacan*, 2.

## **BREAKDOWN**

The term *breakdown* draws on Donald Winnicott's posthumous article "The Fear of Breakdown," published in 1974. Winnicott was referring to mental breakdown associated with a serious failure of the facilitating environment at such an early stage that the self is not yet capable of dealing with it, experiencing it, integrate it, giving it meaning, or retain a recognizable memory of it.

Winnicott describes the temporal paradox that results when the disaster occurs too early in the child's development to be properly experienced. The fear of breakdown is the product of the persistence of this unassimilated experience, which is perceived as a continuing permanent threat even though the disaster has actually already happened.

The interpretation according to which the feared cataclysm has already occurred gives meaning to its reactualization during the transference in response to the minor failures of the holding environment. The

breakdown emphasizes the essential fact that the loss of the object occurred before the object and self were differentiated. Here Winnicott distinguishes his own position from that of Melanie Klein: self and object exist and function during infancy. Yet, for Winnicott, the issue is not an object loss that can be metabolized through introjection (mourning) or incorporation (melancholy), but rather the subject's experience of annihilation, and mental agony.

In this way, at the end of his life, Winnicott completed his conceptualization of the pathogenic infantile deprivation in the environment before the self had had a chance to organize itself: a massive deficiency resulting in the organization of a psychosis and breaks in continuity leading to "psychotic depression." When the self is sufficiently organized, this same situation can lead to antisocial tendencies. Winnicott's "primitive agony" can be compared to the "black hole" of autism described by Frances Tustin.

In these cases, therefore, the recollection of infantile trauma is not to be found in memory traces of the event but in the subject's anguished sense of fragility.

DENYS RIBAS

See also: Autistic capsule/nucleus; Bulimia; Deprivation; Primitive agony; Splitting.

### **Bibliography**

- Winnicott, Donald W. (1974). Fear of breakdown. *International Review of Psychoanalysis*, 1, 103–107.

## **BREAST, GOOD/BAD OBJECT**

The primitive ego cannot perceive or conceive of the objects in its external world as whole, multifaceted persons. Instead it lives in a world of one-dimensional objects that have either good or bad intentions towards the infant (Klein, 1932).

Abraham's concept of whole-object love was a way of talking about the integration of various impulses from all levels of development—the libidinal stages and the phases of early aggression linked with them. All these levels were, in Freud's view, linked and integrated under the dominance of the genital libido. Working with children, Melanie Klein found herself confronted with partial impulses towards objects, toys, and the

person they represented. She was impressed by how pure these relations were, either wholly hating or wholly loving.

She noticed, too, that the objects were related to as if they had similar single-minded attitudes and impulses towards the ego (Klein, 1929). Some objects were feared and hated as terrifyingly violent and punitive, and some were loved for their equal benevolence. The objects themselves had internal states and the ego was greatly preoccupied by their good or bad relations with itself. This sharply redirected her attention from the satisfactions of libidinal impulses toward the relations to objects.

The predominance of the child's hatred and fears led her at first to concentrate on the harshness of objects, and she believed it represented in play a superego of great ferocity (Klein, 1932, 1933). The multiple representations and nuances of these superego figures led her to understand that the superego was not a unitary object but a composite of many figures inside the child. Her attention, once drawn to these internal objects, expanded to recognize an internal world of good objects as well as bad ones.

With her more disturbed patients she noted the concreteness of these internal objects, good or bad. They were conceived by the child as actual physical entities roaming around inside it. She believed that this concreteness is not just explicit in children and disturbed (schizophrenic) adults, but it is also the character of a deep layer of the unconscious in all people.

Klein's observations led her to the view that oedipal configurations occurred in phantasies at a very early age. It became clear to her that the father particularly was regarded for some time as a very restricted function, called in short-hand "father's penis." This occupied mother and took her mentally and physically from the infant. It was thought that at the earliest stages mother was little more than a breast. When she fed, she was "good breast" and when she frustrated she was an evilly intentioned "bad breast." Likewise the penis inside her was a "bad penis" if it was an obstruction in the infant's way to the breast. But it could be a "good penis" if it was felt to protect mother (or the breast) for the infant. The parents as part-objects-breast and penis were believed by the infant to be in some form of intercourse defined by the infant's own phantasies. The bad parents (breast and penis) were

dangerous, threatening to destroy each other, and known as the "combined parent figure." In contrast, the infant in loving mood, could then fantasize in an intercourse of great, benign, and beautiful creativity.

Klein's point of view put great weight on the internalization of these part-objects that loved or hated the infant. Ordinary steady development and sanity depended on the internalization of the good object. This gives rise to an internal good state of mind. The ego develops a continuity in its feeling of being loved. Conversely when introjection is mostly of bad objects there ensues a state of internal turmoil, disorganization and ultimately fragmentation.

The early introjection of a good object/breast results in a benign internal state, and a growth of the ego. The object is drawn into the ego itself or assimilated to become a benign core to the personality. The ego, and the personality, tends therefore to build up from objects that are internalized and assimilated. Bad, evil objects may be internalized and remain unassimilated, constituting a permanent internal threat, often expressed in hypochondriacal complaints.

At a stage when the external objects can be perceived in a more realistic way, there is a tendency, through internalizing them as a mixed object, for the internal state to become populated by objects that are a mixture of good and bad. This poses an alarming change for the personality, known as the depressive position. Its characteristic anxiety—guilt—derives from the sense of the internal object now being a spoiled good object, damaged and with the threat of its death.

The classical Oedipus complex displays a restricted version of the polarities; the one a good source of all libidinal satisfactions, and the other hated parent, thought to be dangerous, obstructing, and castrating.

Klein's early descriptions of an internalized punitive object relate to the concept of the superego, notably a harsh one. The variety of forms of this object, in play, dreams and phantasy manifestations, led her to believe that the superego is a large repertoire of objects, only some of which had moral aspects.

The primitive experience of separating apart good and bad features of the world, does occur in Freud, notably in "Die Vereinigung" ("Negation") (Freud, 1925) where he places the origins of judgment in the narcissistic decision to take in good things and eject bad things.

Fairbairn presented a schema in which the ego, itself split, relates to three internal objects—the libidinal, anti-libidinal and ideal objects—to form three paradigm endopsychic structures. Though there is leeway for much variation in these structures, they are rather different from the free world of internal play and drama of Klein’s internal objects.

Freud’s descriptions of infancy are rooted in the drive theory and are distinct from Melanie Klein’s conception of the good and bad breast. Good and bad objects are in themselves motivated with good or bad intentions towards the ego. The latter downplays the libido theory and promotes object-relations to the center of metapsychology.

ROBERT D. HINSHELWOOD

*See also:* Object; Splitting; Splitting of the object.

### **Bibliography**

Klein, Melanie. (1932). *The psycho-analysis of children*. London: Hogarth Press.

———. (1933). The early development of conscience in the child. In Sándor Lorand, (Ed.), *Psycho-analysis today* (pp. 149–162). New York: Covici-Friede.

———. (1952). *Developments in psycho-analysis* (Joan Riviere, Ed.). London: Hogarth Press.

———. (1975). Infantile anxiety situations reflected in a work of art and in the creative impulse. (Reprinted from *International Journal of Psycho-Analysis*, 10 (1929), 436–443.)

———. (1975). Personification in the play of children. In *The writings of Melanie Klein* (Vol. 1, pp. 199–209). London: Hogarth. (Reprinted from *International Journal of Psycho-Analysis*, 10 (1929), 171–182.)

## **BREASTFEEDING**

Suckling is the action whereby milk is fed to the infant until it is weaned. By extension, the term refers to breastfeeding as well as bottle-feeding. Before an emphasis was placed on the importance of the object and the infant’s environment, psychoanalysts spoke little of maternal suckling. However, Sigmund Freud, in a text that needs to be viewed in historical context, titled “A Case of Successful Treatment by Hypnotism,” evokes the case of a young woman, “occasionally hysterical . . . who is willing to feed her infant but behaves

as if she doesn’t want to” (1892–93a). The dimension of the unconscious conflict is not taken into account here and Freud clings to the idea of will and counterwill. An outline of maternal psychopathology is given, and here the difficulties of breastfeeding are treated by hypnosis.

Suckling is not a psychoanalytic concept. In speaking of suckling we cannot forget the physical link associated with the reality of the nutritive relation. The image of the infant at the mother’s breast has considerable metaphoric and symbolic value; it is an image that makes us nostalgic for a sense of original fulfillment and can be compared with that other, “final,” image of death, as characterized by the iconography of the old man at the breast. The container, the breast, and its content, milk, are both associated with projected fantasies. The milky substance, a liquid that contrasts with the solidity of the breast, is a vehicle of fantasies of fusion and vampirism. Once the infant’s teeth begin to grow, the fantasies are those of oral sadism and cannibalism. There is an analogy to be made between the breast and the penis, between milk and sperm, one of which nourishes and one of which fecundates, and at the same time an incompatibility because sperm is, in fantasy at least, supposed to spoil milk; thus there is a separation between the sexual and the nutritive.

A dichotomy has always existed between the breast as a nourishing object and the breast as an erotic object, a separation that helps avoid the confrontation between an incestuous mother and the importance of maternal libidinal and erotic investment. However, in *The Interpretation of Dreams* (1900a), commenting on the “dream of the Fates (*Knödel*), Freud wrote that “at the woman’s breast love and hunger meet.” For the breast satisfies both the alimentary and the sexual impulses: “To begin with, sexual activity attaches itself to functions serving the purpose of self-preservation and does not become independent of them until later. No one who has seen a baby sinking back satiated from the breast and falling asleep with flushed cheeks and a blissful smile can escape the reflection that this picture persists as a prototype of the expression of sexual satisfaction in later life” (1905d). The nipple is a sexual object throughout Freudian metapsychology. The transition from sucking the nipple to sucking is a key moment in the organization of the earliest feelings of autoeroticism and investment of the mouth as an erogenous zone. Freud does not mention (Laplanche, 1997) the erogenous erotic component for the mother during breast-

feeding. For the infant the breast assumes (secondarily) its forbidden erotic value with the organization of the oedipal conflict; initially the infant simply “is the breast” (Freud, 1941f [1938]), during a period of primary identification with the breast and primal fusion.

It has become obvious that the object plays a key role in enabling the polarization of the libido into certain zones. This follows their unification when the infant is breastfeeding and the libido experiences a sense of satisfaction, at a time when the mouth that sucks and the nipple that nourishes are inseparable and indistinguishable. The mother “(moreover) makes a gift to the infant (while she is lavishing her attention on him) of feelings arising from her own sexual life . . . and clearly grasps these as a substitute for a separate sexual object” (1905d). Freud returned to this position and developed it in his *Outline of Psychoanalysis*: “She is not content to nourish, she cares for the infant and thus awakens in him many other physical sensations, agreeable and disagreeable. Thanks to the care she lavishes, she becomes his first seductress. Through these two relations, the mother acquires unique importance, incomparable, unalterable, and permanent, and becomes for both sexes the object of the first and most powerful of his loves, the prototype of all later amorous relations” (1940a [1938]).

The role of the object and precocious maternal seduction as it occurs through breastfeeding are questioned by contemporary analysts. Jean Laplanche (1987) has developed the idea that sexuality is implanted in the infant through the initial seduction of the adult, and emphasizes the unconscious sexuality of the seducer. From this follows the possibility of a significant reassessment of the role of the impulses, the role of the object, and anaclysis; he also raises the question of the primal. For Paul Denis the question of mastery is present at the heart of the initial experiences of feeding, but the encounter between the mouth and the nipple, to the extent that it combines kinesthetic and sensory feelings, instinctual excitation and pleasure/unpleasure, is an essential period during which the activity of the initial representation takes place (the “pictogram” of Piera Aulagnier, 1975). For authors such as Esther Bick, the emphasis is on the presence-absence of the breast during this primitive stage of undifferentiated autosensuality characterized by the encounter between mouth and nipple. The role of the object remains essential for enabling the consensual union and unification of the libido. The mother’s container function is experienced as a “skin”: “The

optimal object is the nipple in the mouth, together with the mother’s touch (holding), speech, and familiar odor” (1968).

With respect to bottle or breastfeeding, Freud responds only in terms of privation. In all cases there remains a feeling of “having sucked too little and for too short a time,” the nostalgia for the breast being stronger for the child who has been bottle-fed (1940a [1938]). Melanie Klein (1952), writing about breast- and bottle-feeding, returns to the question of the primacy of the object and instinct, the importance of the exterior object and the reality of the breast. For her the breast is the object of intense fantasized projections because it is a primordial object. The cannibalistic oral impulses directed toward the mother’s breast are especially intense. As for the mother, the fact of feeding her baby has a restorative effect because it terminates the sadistic fantasies with respect to her own mother: “The nourishing and beneficial milk she dispenses signifies for the unconscious that her sadistic fantasies have not been realized and that their objects have rediscovered their integrity” (1932).

For Donald Winnicott breastfeeding is expanded to the baby’s environment in the broad sense and to the richness of the experience the mother offers. The quality of maternal holding and handling is essential, for these are both a function of the mother’s internal conflicts and of her own infantile experiences. The foundations of psychic health depend on this “facilitating environment.” The experience of the survival of the object in the face of the baby’s attacks seems to her essential and in the end helps her advance the idea of difference “between the survival of a part of the mother’s body and the survival of a bottle” (1987). Although he is cautious when discussing mothers and does not dismiss the unconscious maternal implications, he emphasizes the importance of the carnal reality of the experience of the breast; in this body-to-body relation, the exchange of glances and the sensual experience are essential to communication.

Breastfeeding is a situation that so profoundly involves the mother’s body and psychic life that it is subjected to the unconscious conflicts that affect the mother and to the fantasies awakened through the encounter between a specific mother and a specific infant. Suckling extends the period of pregnancy and birth and is inseparably a part of the woman’s sexual life and her life history. Primitive psychic activity is associated with these very first contacts that are always difficult to conceptualize.



Psychoanalysts who care for infants are conscious of this in their clinical activity and research.

The invention of the bottle (1820), followed by the introduction of sterilization (1892–1898), have profoundly altered breastfeeding. Artificial milk eliminates the need for direct recourse to another woman, in the position of wet-nurse, and the baby's survival (in reality) no longer depends on the product of the mother's body. The transition from mother's milk to artificial milk, while it abandons its natural origins, cannot be assimilated to the transition from raw food to cooked food discussed by Lévi-Strauss. But how can social and cultural ideology be made to mesh with unconscious maternal choices?

JOYCELINE SIKSOU

See also: Early interactions; Erotogenic zone; Holding; Weaning.

### **Bibliography**

- Bick, Esther. (1968). The experience of the skin in early object relations. *International Journal of Psycho-Analysis*, 49, 558–566.
- Castoriadis-Aulagnier, Piera. (1975). *La Violence de l'interprétation. Du pictogramme à l'énoncé*. Paris: Presses Universitaires de France, "Le Fil rouge."
- Delegay-Siksou, Joyceline. (1986). Allaiter: au sein ou au biberon? Nourrir un enfant. *Lieux enfance*, 6–7, 35–57.
- Denis, Paul. (1997). *Emprise et satisfaction, les deux formants de la pulsion*. Paris: Presses Universitaires de France.
- Freud, Sigmund. (1892–93a). A case of successful treatment by hypnotism *SE*, 1: 115–128.
- . (1900a) The interpretation of dreams. Part I., *SE*, 4: 1–338; The interpretation of dreams. Part II., *SE*, 5: 339–625.
- . (1905d). Three essays on the theory of sexuality. *SE*, 7: 123–243.
- . (1940a [1938]). An outline of psycho-analysis. *SE*, 23: 139–207.
- . (1941f [1938]). Findings, ideas, problems. *SE*, 23: 299–300.
- Klein, Melanie. (1952). En observant le comportement des nourrissons. In Joan Riviere (Ed.), *Developments in psycho-analysis*. London: Hogarth Press
- . (1952). Quelques conclusions théoriques concernant la vie émotionnelle des bébés. In Joan Riviere (Ed.), *Developments in psycho-analysis*. London: Hogarth Press.

Laplanche, Jean. (1987). *Nouveaux Fondements pour la psychanalyse*. Paris: Presses Universitaires de France.

———. (1997). Le prégénital freudien à la trappe: après l'analyse. *Revue française de psychanalyse*, 61, 4: 1357–1369.

Winnicott, Donald W. (1987). *Babies and their mothers*. (Clare Winnicott, Ray Shepherd, and Madeleine Davis, Eds.). Reading, MA: Addison-Wesley.

### **Further Reading**

Sarlin, Charles N. (1981). The role of breast feeding in psychosexual development and the achievement of the genital phase. *Journal of the American Psychoanalytic Association*, 29, 631–642.

---

## **BRENTANO, FRANZ VON (1838–1917)**

Franz von Brentano, a German Dominican philosopher and theologian, was born in Marienberg in 1838 and died in Zürich in 1917. His ideas influenced Edmund Husserl and Martin Heidegger. It was in 1874, the year Brentano published his *Psychologie vom empirischen Standpunkt* (Psychology from an empirical standpoint), that the young Sigmund Freud, an eighteen-year old student, wrote to his friend Eduard Silberstein[RB1], "I, a doctor and atheist empiricist, I have signed up for two courses in philosophy . . . One of the courses—you will be amazed when you hear this—concerns the existence of God; Prof. Brentano, who is teaching the course, is a man, a thinker, and a marvelous philosopher." On March 7, 1875, he added, "Both of us (me and Paneth) have grown closer to him, we sent him a letter with our objections and he invited us to his home, refuted us, seemed to take an interest in us. . . . Concerning this remarkable man (he is a believer, a teleologist [!] and a Darwinist, and damned intelligent, even brilliant), who in many ways satisfies the requirements of the ideal, I will have much to tell you in person. But I can give you this piece of news now: under Brentano's influence especially (which has had a maturing effect), I have made a decision to sit for the doctorate in philosophy and will study philosophy and zoology."

The most detailed report of the visit to Brentano shows how he influenced Freud: "He totally condemns [Herbart's] a priori constructions in psychology and feels that it's unforgivable that he never thought of considering spontaneous experience or provoked experience to see if they confirmed his gratuitous

hypotheses; he claims unhesitatingly to belong to the empirical school, which applies the method of natural science to philosophy and, in particular, to psychology (this is, in fact, the principal advantage of his philosophy, the only thing that makes it bearable for me), and he revealed to us several interesting psychological observations that show the inanity of Herbart's speculations. According to him, it is more necessary to submit certain specific problems to more extensive research, in order to achieve definite partial results, than to claim to embrace philosophy as a whole, which is not possible, given that philosophy and psychology are still young sciences, which cannot expect any support, especially from physiology."

Aside from the affirmation of empiricism and the primacy of observation and experiment that Freud would never forget, the meeting with the Catholic theologian is the only time that Freud, "an atheistic Jew," had a momentary metaphysical hesitation. He described the experience as follows: "Ever since Brentano imposed his God on me with ridiculous facility, through his arguments, I fear being seduced one of these days by proofs in favor of spiritualism, homeopathy, Louise Lateau, etc. . . . It's a fact that his God is nothing but a logical principle and that I have accepted it as such. Yet, we proceed down a slippery slope once we acknowledge the concept of God. It remains to be seen at which point we stumble. Moreover, his God is very strange. . . . It is impossible to refute Brentano before hearing him out, studying him, exploring his thought. Confronted with such a rigorous dialectician, we must strengthen our intellect by addressing his arguments before confronting him directly."

Freud's connection to philosophy lasted longer than this first contact, and it was Franz von Brentano who suggested to Theodor Gomperz, five years later, that Freud translate the twelfth volume of the *Complete Works* of John Stuart Mill (1880a), which contained "On the Emancipation of Women," "Plato," "The Social Question," and "Socialism."

ALAIN DE MIJOLLA

*See also:* Breuer, Josef; Hard science and psychoanalysis; Philosophy and psychoanalysis; Self-consciousness; Vienna, University of.

### **Bibliography**

- von Brentano, Franz. (1874) *Psychology from an empirical standpoint*. Edited by Oskar Kraus, English edition edited by Linda L. McAlister, translated by Antos C. Rancurello, D. B. Terrell, and Linda L. McAlister, with a new introduction by Peter Simons. London, New York: Routledge, 1995.
- Freud, Sigmund. (1989a) [1871–81, 1910]. *The letters of Sigmund Freud to Eduard Silberstein, 1871–1881* (Walter Boehlich, Ed.; Arnold J. Pomerans, Trans.). Cambridge: Harvard University Press.

---

### **BRETON, ANDRÉ (1896–1966)**

A French poet, the founder and theoretician of the surrealist movement, André Breton was born February 19, 1896, in Tinchebray, France, and died in Paris on September 28, 1966. Until he was four years old, Breton was raised in Brittany by his maternal grandfather. Nostalgia for those early years of astonishment, fear, and surprise never left Breton. In 1907 he entered the Lycée Chaptal in Paris. In 1913 he began studying medicine, published his first verses, and established literary friendships, first with Paul Valéry, followed by Guillaume Apollinaire and Pierre Reverdy.

Mobilized in 1915, in July 1916 he asked to be assigned to the army's neuropsychiatric center in Saint-Dizier. This period had a "decisive influence" (*Conversations*, 1952) on Breton. As a student of medicine, he observed his patients with close attention. He developed a strong interest in psychiatry and in Freud, whose ideas he encountered for the first time in Emmanuel Régis's *Précis de psychiatrie*. As a poet he began to ask questions about literary creation. The discourse of madness contained striking images, how did these come into being? How did madmen and poets develop their language? What was the relationship between subject and object embodied in language?

Freud provided a response to these fundamental questions but Breton had access to them only in the form of Régis's introduction. As a result his concept of Freudian analysis was distorted. Although Breton understood the role of the libido, the conflict between desire and censure, and the dream work that provides insight into the artistic process, he believed with Régis that the analytic method was a mechanized collection of the subject's verbal outpourings, which he repeated as they popped into his mind, like a "recording device"

(Régis). This was a formula Breton was to use in his *Surrealist Manifesto*: “We ... who have turned ourselves into ... modest recording devices in our art ...” (1924). Transference, the analyst’s suspended attention in the face of the representations supplied by the subject or their interpretation, dream associations, all of this disappeared. Although Breton continued his medical training until 1920, he was not interested in therapy. His meeting with Freud in 1921 had no affect on him (1924). The problems he wanted to resolve were different: “There is the entire question of language.” (1919)

With psychoanalysis, Freud provided Breton with a theory of language. “Those verbal representations that Freud claims are ‘memory traces arising principally from acoustic perceptions’ are precisely what constitute the raw material of poetry” (1935). The poet as dreamer is the “receiver of Indirect Contributions” supplied by the figurative activity of the preconscious mind, where representations of words and things make contact with one another. He “yields to the collage” of associations (1919). This leads to the creative experiments Breton conducted from 1919 to 1924 (automatic writing, hallucinosis, half-sleep, automatic writing, and others), which found a large number of applications in literature.

In the *Surrealist Manifesto*, Breton condensed the theoretical conclusions he drew from his experiments. This was the founding text of the surrealist movement that did so much to introduce Freudian ideas to France and elsewhere. Although Breton used Hegelian dialectics to criticize Freud (*Communicating Vessels*, 1932; the republication of 1955 contains three letters from Freud to Breton), he continued to study him (*Carnet*, 1921, *Cahier de la girafe sur la Science des rêves*, 1931, *Position politique du surréalisme*, 1935, *Anthology of Black Humor*, 1940) and emphasize the importance of his thought. “Surrealism ... considers the Freudian critique of ideas ... to be the first and only one with a basis in fact” (1930).

NICOLE GEBLESCO

See also: Claude, Henri Charles Jules; Literature and psychoanalysis; Surrealism and psychoanalysis.

### **Bibliography**

Alexandrian, Sarane. (1974). *Le surréalisme et le rêve*. Paris: Gallimard.

Bonnet, Marguerite. (1975). *La violence du voir*. Paris: Presses Universitaires de France.

Breton, Andre. (1988, 1992). *Œuvres complètes* (M. Bonnet, Ed.). Paris: Gallimard, La Pléiade.

Carrouges, Michel. (1950). *André Breton et les données fondamentales du surréalisme*. Paris: Gallimard.

Pontalis, Jean-Bertrand. (1978). Les vases non communicants. *N.R.F.* 302, 26–45.

---

## **BREUER, JOSEF (1842–1925)**

Josef Breuer, an Austrian doctor, was born January 15, 1842, in Vienna, where he died on June 20, 1925. Breuer, the son of a liberal Jewish professor of theology, studied medicine in Vienna and obtained his degree in 1864. He served as an assistant in internal medicine to Theodor Oppolzer, and worked on heat regulation and the physiology of respiration (Hering-Breuer reflex); upon becoming a practitioner in 1871, he set up his practice in Vienna. He also conducted research on the function of the inner ear (Mach-Breuer theory of the flow of endolymphatic fluid) and, although he became a specialist in internal medicine in 1874, he returned to his research in 1884.

He was the friend and family doctor of several members of the Vienna Teachers College and of Viennese high society. He maintained a correspondence with artists, writers, philosophers, psychologists, and colleagues in his field, and in 1894 was elected a corresponding member of the Academy of Sciences. Well versed in philosophy, Breuer was interested in the theory of knowledge and the theoretical foundations of Darwinism (1902 conference, exchange of letters with Franz von Brentano). He was an active participant in discussions on the foundations of politics and ideology, and discussed issues of art, literature, and music. As an assimilated and enlightened Jew, he adopted a kind of pantheism that he derived from Goethe and Gustav Theodor Fechner. His favorite aphorism was Spinoza’s *suum esse conservare* (preserve one’s being). He was gripped by a form of skepticism and spoke, following William Thackeray, of his “demon ‘but’,” which forced him to question any newly acquired knowledge. Because of his detailed knowledge of the history of ideas and social history, his appreciation of the political conditions of his era, as well as for reasons having to do with his own life, he believed it was nearly impossible for him to undertake a questionable action.

Underlying Breuer's research on physiology was the quest for the relation between structure and function, and thus for a form of teleological query. He was particularly interested in regulatory processes in the form of self-control mechanisms. Unlike a number of physiologists in the so-called biophysicalist movement, inspired by Ernst Brücke, Hermann von Helmholtz, and Emil Du Bois-Reymond, Breuer believed in neovitalism.

In 1880–1882 Breuer treated a young patient, Bertha Pappenheim (Anna O.), for a nervous cough and a multitude of other hysterical symptoms (mood swings, alterations in states of consciousness, visual disturbances, paralysis and contractions, aphasia). During the many long interviews, doctor and patient saw that some symptoms disappeared when the memory of their first appearance returned and could be reproduced, and the associated affects could be awakened and abreacted. This occurred at specific times of day, during spontaneous auto-hypnotic states. Based on these observations, initially accidental, patient and doctor developed a systematic procedure whereby the individual symptoms were gradually recalled during their appearance in reverse chronological order, until they disappeared for good following a reproduction of the original scene. Sometimes artificial hypnosis was used during therapy if the patient was not in a state of auto-hypnosis. The patient, who at times “forgot” her native language and understood only English, jokingly referred to this therapy as the talking cure, or chimney sweeping.

During the therapy, a stay at a clinic near Vienna was required because of the patient's heightened risk of suicide. In spite of the apparent and surprising success of the method, certain manifestations remained. These included the temporary loss of her native language and violent neuralgia of the trigeminal nerve, which required morphine treatment, leading to addiction. Because of her symptoms Breuer had his patient admitted for further treatment to Dr. Ludwig Binswanger's Bellevue sanatorium in Kreuzlingen in July 1882. She left in October, improved but not fully cured (*Histoire de la maladie*, in Hirschmüller, A. 1978). She lived until 1888 in Vienna, was treated on several occasions, then moved to Frankfurt, where she had an active life as a writer, social worker, defender of women's rights, and a leader of the movement of Jewish women in Germany (Jensen, E. 1984; Tisseron, Y. 1986; Heubach, H. 1992).

In 1882 Breuer discussed the case with his colleague Sigmund Freud, fourteen years his junior. Freud tested Breuer's method on patients after he began working as a neurologist. Starting from the theories of Jean Martin Charcot, Pierre Janet, August Ferdinand Möbius, Hippolyte Bernheim, and others, they jointly developed a theoretical framework for the operation of the psychic apparatus and for their therapeutic procedure, which they called the “cathartic method” in reference to Aristotle's ideas about the function of tragedy (catharsis as the purification of the spectators' emotions). In 1893 they published a preliminary report entitled “On the Psychic Mechanisms of Hysterical Phenomena”. This was followed two years later by the *Studies on Hysteria*, the “cornerstone of psychoanalysis” (Ilse Grubrich-Simitis), establishing the foundations of the field. There was a chapter on theory (Breuer), a chapter on therapy (Freud), and five case histories (Anna O., Emmy von N., Katharina, Lucy R., Elisabeth von R.).

Freud continued to develop the theory and technique as they developed the work jointly (defense neuroses, free association). Breuer was not convinced by the exclusive emphasis on sexual factors and Freud saw Breuer's caution as a sign of aloofness. In 1895 the distance between the two men increased, resulting in the end of their collaboration. Breuer continued to take an interest in the development of psychoanalytic theory but abandoned cathartic therapy. Freud later proposed the hypothesis that Anna O.'s treatment had been suddenly interrupted because of a violent erotic transference, accompanied by hysterical pregnancy and childbirth. This version of events, constructed retroactively by Freud and spread by Ernest Jones, among others, cannot withstand historical scrutiny. More recent attempts to show that the description of the case of Anna O. was a “fraud” (Mikkel Borch-Jacobsen) are a form of unsubstantiated polemic.

ALBRECHT HIRSCHMÜLLER

*See also:* Anna O., case of; “Autobiographical Study, An”; Autosuggestion; Cathartic method; Conversion; Free energy/bound energy; Hypnotic states; Hypnosis; Hysteria; Memory; *On the History of the Psychoanalytic Movement*; Pappenheim, Bertha; Psychic energy; Remembering; Reminiscence.

### **Bibliography**

- Breuer, Josef. (1986). *Die krisis des Darwinismus und die teleologie. Vortrag, gehalten am 2.5.1902*. Tübingen: Diskord.
- Ebner-Eschenbach, Marie von; Breuer, Josef. (1969). *Ein briefwechsel, 1889–1916*. Vienna: Robert A. Kann.
- Hirschmüller, Albrecht. (1978). *Physiologie und psychoanalyse in leben und werk Josef Breuers*. Bern-Stuttgart: Hans Huber.
- Jensen, Ellen M. (1970). "Anna O: A study of her later life." *The Psychoanalytic Quarterly*, 39, 269–93.
- . (1984). *Streifzüge durch das leben von Anna O.-Bertha Pappenheim. Ein fall für die psychiatrie. Ein leben für die philanthropie*. Dreieich.
- Pappenheim, Bertha. (1992). *Sisyphus. Gegen den Mädchenhandel Galizien: Bertha Pappenheim, die Anna O.* In Helga Heubach (Ed.), Freiburg im Breisgau. *Le Travail de Sisyphé*. (1986). Paris: Des femmes-Antoinette Fouque.

---

### **BRIERLEY, MARJORIE FLOWERS (1893–1984)**

Marjorie Flowers Brierley, British psychoanalyst, was born on March 24, 1893, and died on April 21, 1984.

Entering University College, London, in 1916, she gained her BSc Hons (first class in psychology) in 1921, and her MB BS in 1928, registering as a medical practitioner in 1929. Concurrently, she trained with the British Psycho-Analytical Society, having personal analysis with John Carl Flugel (1922–1924), and Edward Glover (1925–1927). She was "passed for practice" in October 1929, becoming a full member in 1930, and training analyst, control analyst and lecturer to students in 1933.

In 1922 she married William B. Brierley, botany professor at Reading University, formerly husband to Susan Isaacs.

Between qualification and the late 1940s she served actively on many committees of the British Society, including the Training Committee and Board and Council, and helped organize the Controversial Discussions of 1943–1944 (King, Pearl, 1991). She read thirteen papers to the Society and published eleven papers, thirty-one book reviews and twenty-four abstracts in the *International Journal*, and one book. In 1954 her husband retired and they moved to the country, whence she published twenty-six further book reviews and two articles, continuing as assistant editor of the *International Journal* until 1978.

Her earliest psychoanalytic publications, two papers on the then-topical subject of female development (1932, 1936), were notable for scholarship and independence; Brierley was, though not aggressive about it, one of those who differed from Freud. Her book, *Trends in Psycho-Analysis* (1951), contained versions, sometimes revised or expanded, of all her other papers of 1934–1947. These included "Affects in Theory and Practice," a concise and original review, which aimed to restore affects (which had never lost their importance in psychoanalytic practice) to their consonant place in theory, which had lapsed into disuse after Freud focused more on repressed unconscious and instinct theory. The chapter "Problems Connected with the Work of Melanie Klein" derived from her papers "A Preparatory Note on Internalised Objects," and "Internal Objects and Theory," and on contributions Brierley made to the Controversial Discussions.

Valuing the great enrichment of Klein's new ideas of infantile phantasy and object relationships, she acutely explored problems concerning *inter alia* precocity, regression, and differences between stages, as well as terminology confusing concept and phantasy conceptually. A later chapter extended this differentiation to describe two independent aspects of psychoanalytic theory, the abstract objective, "Metapsychology," and the subjective, which she named "Personology." Later sections explored metapsychology as "Process Theory," and many other aspects and ramifications of psychoanalytic thinking.

John Bowlby described Brierley as "[p]robably having a better grasp of scientific principles than anyone else" (King 1991), regarding her 1937 paper on affects. This paper was considered "seminal" and as "opening a new era in understanding," when the 1977 International Congress took "Affect" as its main theme. Calm and open-minded, she contributed significantly towards the partial resolution of acrimonious disputes within the British Society prior to and after the Controversial Discussions. During them, her clarifying contributions were much valued by both sides. Her writings are remarkable for concision, clarity, scholarship, intelligence and great intuitive sensitivity.

ANNE HAYMAN

See also: British Psycho-Analytical Society; Controversial Discussions.

### Bibliography

- Brierley, Marjorie. (1932). Some problems of integration in women. *International Journal of Psycho-Analysis*, 13, 433–448.
- . (1936). Specific determinants in feminine development. *International Journal of Psycho-Analysis*, 17, 163–180.
- . (1951). *Trends in psycho-analysis*. London: Hogarth.
- Hayman, Anne. (1986). What do we mean by phantasy? *International Journal of Psycho-Analysis*, 70, 105–114.
- King, Pearl H. M., and Steiner, Riccardo. (1991). *The Freud-Klein controversies 1941–1945*. London, New York: Tavistock Publications-Routledge, New Library of Psychoanalysis.

### BRILL, ABRAHAM ARDEN (1874–1948)

The American psychiatrist Abraham Brill was born on October 12, 1874, in Kanczuzg, Austria (then Galicia) and died on March 2, 1948, in New York City.

His father was a noncommissioned officer in the Austrian Army who served with Maximilian in Mexico. After spending his childhood in Austria, Brill emigrated to the United States in 1889 at age fifteen, without his family and with almost no money. He worked to support himself through high school and college, graduating from New York University in 1901. He received an MD degree from the College of Physicians and Surgeons, Columbia University in 1904.

Brill worked as a psychiatrist in the New York State Mental Hospital System at the Central Islip State Hospital under the tutelage of Adolph Meyer and August Hoch. From 1902 to 1907, he traveled in Europe, first to Paris and then, at the suggestion of Frederick Peterson, to Zürich; there he learned about Freud's new science, psychoanalysis, from the staff of the Burgholzi Psychiatric Clinic (which included Eugen Bleuler and Carl Jung). He returned to America a year later and accepted a position as assistant physician of mental disease, Bellevue Hospital, which he held until 1911. In 1909 he attended the Clark University Conference, traveling with Freud's party from New York. He became the first practicing psychoanalyst in America and interested a small group of New York psychiatrists in psychoanalytic ideas.

In 1911, Sigmund Freud urged Ernest Jones to establish the American Psychoanalytic Association (APA) with James Jackson Putnam as president, and Brill as secretary. Brill refused to participate and instead, on February 12, 1911, with fifteen other physicians, founded the New York Psychoanalytic Society,

several months before the APA was established in May of that year. From that time to the close of the First World War the New York Psychoanalytic Society was kept alive, practically single handedly, by Brill. He was the expositor and public advocate of psychoanalysis par excellence. He spoke at medical, neurological, and psychiatric societies, and to lay groups as well. He lectured to social workers, the New York City Police College, the Education Department of NYU—many of these lectures were reprinted in professional journals and lay publications. During the 1930s he presented a weekly radio broadcast lecture on mental health themes.

Of greatest importance for the dissemination and promulgation of psychoanalytic ideas in America were Brill's translations. Brill translated into English the major work of Sigmund Freud, some of Carl Gustav Jung's works, and Bleuler's *Textbook of Psychiatry*. His own publications included numerous journal articles and important books, including *Psychoanalysis* (1921). His *The Basic Writings of Sigmund Freud* was published in 1938.

Abraham Arden Brill's importance to psychoanalysis was also as a leader of both psychoanalytic and psychiatric institutions. Brill became a member of the APA in 1914. He served as president of the APA in 1919 and 1920 and again from 1929 to 1935. He was president of the New York Psychoanalytic Society from 1911 to 1913 and from 1925 to 1936. His influence on psychoanalysts both in New York and the United States was at its zenith between 1929 to 1936. During this period he played a central role in restricting membership in the New York Society and in the APA to physicians. He defied Freud, who was supportive of lay analysis, because of his concern about "quackery," medical treatment by poorly trained or unauthorized practitioners. It was Brill's conviction that the survival of psychoanalysis in the United States depended on maintaining its medical identity.

Brill also played an important role in achieving autonomy for the APA within the International Psychoanalytic Association (IPA). These organizational and credential principles were maintained until overturned by the settlement of a lawsuit brought against the IPA, the New York and Columbia Psychoanalytic Institutes, and APA by a group of psychologists in the 1980s. From the years immediately preceding World War II and until his death in 1948, Brill was displaced first by the Americans Bertram Lewin and Lawrence Kubie, and then by the Viennese psychoana-

lysts who emigrated to New York to escape Nazi persecution. However, he remained a proud and respected figure who more than any other psychoanalyst was responsible for the growth of psychoanalysis in the United States.

ARNOLD D. RICHARDS

*See also:* Frink, Horace Westlake; International Psychoanalytic Association; Lay analysis; New York Psychoanalytic Institute; United States.

### **Bibliography**

Hale, Nathan G., Jr. (1995). *The rise and crisis of psychoanalysis in the United States: Freud and the Americans 1917–1985*. New York: Oxford University Press.

---

## **BRITISH PSYCHO-ANALYTICAL SOCIETY**

The London Psycho-Analytical Society, formed in 1913, was composed of thirteen members, only four of whom worked as psychoanalysts, while others agreed with Jung. On February 20, 1919, ten members interested in Freud's work agreed to disband that group and to re-form it as the British Psycho-Analytical Society. They decided only to accept as members, those who were interested in and practiced psychoanalysis. The members elected Dr. Ernest Jones as president and decided that members and associate members should be elected. They drew up rules for the Society, and in 1924 the Institute of Psycho-Analysis (IPA) was set up to hold property, to deal with financial and other matters concerning publication. Later the Institute became responsible for the administration of the Clinic and of training activities. The officers of the Society were responsible for the scientific activities of members and were its link with the IPA.

In 1926, the London Clinic of Psychoanalysis was established. Members gave one session a day freely to the Clinic, for the next thirty years. It was disclaimed from the National Health Service (NHS) in 1948–49 and it is still an independent clinic. As membership increased, so the committee structure expanded, and after 1946 committees were governed by the "Gentleman's Agreement." In September 1972 the Society was registered as a Charity: No. 264314.

By 1920 there were thirty members and associate members of the British Society. During the 1920s several members of the British Society went to Europe for

analysis with Freud, Hans Sachs, Karl Abraham and Sandor Ferenczi. The approach of these analysts influenced the British approach to psychoanalysis. By 1925 there were fifty-four members of the Society, who came from a number of professional disciplines, among them were psychiatrists, medical practitioners, teachers, graduates and "gentlemen scholars." In 1927 Melanie Klein became a member of the Society and she brought with her various scientific differences with the Viennese, and especially with Anna Freud.

After 1933 the growth of anti-Semitism under Hitler put the lives of Jewish psychoanalysts in danger, first in Germany, and then from 1938 in Austria. Many became refugees, and some of them, including the Freuds, accepted membership of the British Society, to the great enrichment of psychoanalysis in London. Originally, to become a member, associates read a clinical paper to the Society or to a Panel, but since 1975, they have had the option of taking a two-year membership course.

In 1925 at the Bad Homburg Congress in Germany, the first Conference of delegates from branch societies took place and agreed that training should be the responsibility of a training committee and not of an individual. In 1926, the British elected their first training committee and formalized their training. The need for medical qualifications was discussed but most members of the Society supported Freud's point of view against this requirement.

Disagreements in the British Society and criticisms of Melanie Klein's theories led to the "controversial discussions," which were concerned with what kind of psychoanalysis should be taught to students. Following these discussions, Glover resigned from the Society and Anna Freud resigned from the training committee. When Sylvia M. Payne was elected as President in 1944, she suggested a change in the training program in order to include Anna Freud's approach to psychoanalysis. Training was divided into Course A, which catered to the majority of the British Society (i.e. the Middle Group and the Kleinians) and Course B, which catered to Anna Freud's approach. In order that no one group could dominate the others, it has been agreed that all committees contain representatives of each group. This was not written down in the Society rules, so it was called the "gentlemen's agreement." Groups are now designated as Kleinian, Independent (Rayner, 1991), and Contemporary Freudian.

These earlier training arrangements were revised in the early 1960s when a separate curriculum committee was set up alongside the training committee. Later in 1973, after much research, a new structure was agreed upon, which allocated aspects of the training process to separate sub-committees, whose chairmen were members of the policy-making education committee. Training takes place primarily in London, although special arrangements have been made for selected students from Scotland and Northern Ireland to be trained as psychoanalysts.

Since 1919 the scientific and clinical interests of members have included the role of anxiety, hostility and aggression, the theory of symbolism, character problems, the origin and structure of the superego, problems of psychoanalytic technique, a psychoanalytic theory of psychoses, and the psychoanalysis of children. They also applied psychoanalytic understanding to the arts, educational, and social issues.

Interest in the early development of infants and the possibility of analyzing them increased with the move of Klein to London in 1927. Her ideas started to have implications for work with adult patients, which some members considered to be incompatible with Freud's approach. Klein's critics objected to her use of fantasy, her interpretation of Freud's concept of the death instinct, and her concept of internal objects. When Anna Freud and her colleagues arrived in 1938, they joined Klein's critics. Between 1942 and 1944 Scientific Meetings were arranged to explore these differences, after which members agreed to differ within the context of the gentleman's agreement (King and Steiner 1991).

After the Second World War the scientific life of the Society continued to be characterized by interest in child analysis, psychotic and borderline conditions and the application of psychoanalysis to the arts and social issues. The division into three groups created at times serious disagreements, but properly contained they contributed to the creativity and liveliness on the scientific life of the Society. In the early twenty-first century, the scientific differences between members have decreased, and interest now centers on technique and the "here and now" of the analytic relationship rather than on the elucidation of theoretical issues and concepts.

As papers on applied subjects were seldom read at Scientific Meetings, in 1968 a special Section was set up that became known as the "Applied Section." Through this section and courses of public lectures,

alongside the Annual Ernest Jones Lecture, links have been made with colleagues from other professional disciplines.

During the 1920s, Susan Isaacs did research on the social and intellectual development of young children in the Malting House School, Cambridge (Isaacs 1933). In 1932, Edward Glover carried out and later published research on the way members of the Society worked as psychoanalysts (Glover and Brierley 1940). In 1957, the Research Committee was set up to facilitate applications for members' research. Interest also centers on the conceptualization in statistical terms of the outcome and effectiveness of psychoanalysis. In 1981, the Erich Simenauer Foundation was set up, through the generosity of the late Prof. Simenauer, who was an Honorary Member of the Society, to support and encourage psychoanalytic research work.

After Ernest Jones died, his remaining papers were given to the Archives of the Society. They cover his work for the International, as well as for the Society. When Pearl King became honorary archivist, she began to index the Archives on a computer database. This is an ongoing task. The Archives have become an important center for research into the history of psychoanalysis.

In 1920, the *International Journal of Psycho-Analysis* started publication—the first psychoanalytic journal in the English language. A Glossary Committee of Joan Riviere, James and Alix Strachey, and Ernest Jones, worked in collaboration with the Freuds on the task of translating Freud's work and concepts from German into English. In 1924, The International Psycho-Analytical Library was started with the Hogarth Press. In 1986, the Institute launched The New Library of Psychoanalysis in cooperation with Tavistock and then Routledge.

Following the Second World War, the Society sponsored the translation of Freud's complete psychological works into English and their publication in twenty-four volumes as the *Standard Edition*. James Strachey carried the main responsibility for this great achievement, with the help of Anna Freud (Steiner 1987). A revised Standard Edition is planned; it is to include matter from previously unknown papers, corrections, and a glossary of German words having controversial translations.

Professional and public concern with the legitimacy of psychoanalysis as a medical specialty led the British Medical Association in 1927 to set up a committee to investigate it. After meeting for two years, they agreed



not to oppose the use of psychoanalysis, by those trained by the Institute of Psycho-Analysis, as a treatment for mental illness. Since then the Society has presented evidence to a number of Royal Commissions.

In 1956, on the centenary of Freud's birth, the London County Council placed a commemorative plaque on the house where he had lived in Maresfield Gardens, Hampstead. In 1986, following the death of Anna Freud, this house was opened by Princess Alexandra as the home of the Freud Museum. In 1975 David Astor donated the money for a Freud Professorship at University College, London. Initially, the professors were appointed annually, but in 1984 Dr. J. J. Sandler was appointed as the first full-time Freud Professor. The Society built up close links with hospitals in the NHS, especially with the Tavistock Clinic and the Cassel Hospital, which resulted in their facilitating the training of psychoanalysts who were on their staff. The Society also supported the Anna Freud Center in its training of child psychotherapists and child psychoanalysts.

Several members of the British Psycho-Analytical Society have held important professional roles in the psychoanalytical world: Ernest Jones, William H. Gillespie, Adam Limentani and Joseph Sandler were presidents of the IPA. The Society has organized four IPA Congresses: in Oxford in 1929, in London in 1953, in Edinburgh in 1961 and in London in 1975. The Society was responsible to the IPA for the Sponsoring Committees for Australia and Canada, and it has trained candidates from many countries.

Joseph Sandler and Anne Marie Sandler were Presidents of the European Psychoanalytical Federation. Since 1969, every two years the Society has organized the English Speaking Conference for European psychoanalysts.

PEARL KING AND RICCARDO STEINER

*See also:* Controversial Discussions; Jones, Ernest; *International Journal of Psychoanalysis*, *The Standard Edition of the Complete Psychological Works of Sigmund Freud*.

### **Bibliography**

Glover, Edward, and Brierley, Marjorie. (1940). *An investigation of the technique of psycho-analysis*. London: Bailliere, Tindall and Cox.

Isaacs, Susan. (1933). *Social development in young children*. London: Routledge.

King, Pearl H. M., and Steiner, Riccardo. (1991). *The Freud-Klein controversies 1941–1945*. London, New York: Tavistock Publications-Routledge, New Library of Psychoanalysis.

Rayner, Eric. (1991). *The independent mind in British psycho-analysis*. London: Free Association Books.

Steiner, Riccardo. (1985). Some thoughts about tradition and change arising from an examination of the British Psycho-Analytical Society's "Controversial Discussions," 1943–1944. *International Review of Psycho-Analysis*, 12, 27–71.

---

## **BRÜCKE, ERNST WILHELM VON (1819–1892)**

A German doctor and physiologist, Ernst Wilhelm von Brücke was born June 6, 1819, and died January 7, 1892, in Vienna. The son of a portrait and historical painter, following his mother's premature death he was raised by his uncle, the superintendent C. Droyesen, in Stralsund. He studied medicine in Berlin and Heidelberg in 1838 and became a doctor of medicine in Berlin in 1842. In 1843 he became an assistant to Johannes Müller at the Museum of Comparative Anatomy and a prosector; in 1846 he also served as a teacher of anatomy at the Academy of Fine Arts in Berlin.

Brücke completed his degree in physiology in 1844 and was appointed full professor of physiology and general pathology in Königsberg, and professor of physiology and (microscopic) anatomy in Vienna, where he held the chair of physiology for forty years, until his appointment as professor emeritus in 1890. He was ennobled in 1873 and became rector of the University of Vienna in 1879. He was a member of the Academy of Sciences, the Prussian Order of Merit, and the Upper House of Austria, and received numerous decorations and honorary distinctions. As a co-founder of the Physics Society in 1845 (the Berlin and later the German Physics Societies were offshoots of this organization), he was, along with Emil Du Bois-Reymond, Hermann von Helmholtz, and Karl Ludwig, one of the defenders of organic physics, which, in contrast to the then-dominant vitalist tradition, held that all vital manifestations were the result of physico-chemical forces in the organism.

Brücke was the most learned physiologist of his time and helped enrich several areas of natural science. He was active in the physiology of optics, the physiology of

plants, the physiology of digestion, of the blood, the nerves, and the muscles, cellular physiology, biochemistry (the purification of pepsins, which led to our understanding of enzymes), the physiology of speech, and even linguistics. His many publications included the two-volume *Vorlesungen über Physiologie* (Lessons on Physiology; 1873, 1874). Brücke's laboratory was a place where fundamental research on the exact sciences of nature was carried out and he introduced a new methodology to the Vienna school of medicine, which was strongly influenced by his work.

Sigmund Freud, who described Brücke as the "highest authority who has ever had an influence on me," worked in Brücke's laboratory between 1876 and 1882. His earliest writings on neurophysiology are based on his work there and Brücke's influence is clearly evident in Freud's earliest theoretical writings on psychoanalysis. Brücke, who had sponsored Freud for a professorship, referred, in his letter of recommendation, to Freud's work on neurology as being "very important." He also helped Freud obtain the travel stipend that allowed him to work with Charcot in Paris.

HELMUT GRÖGER

*See also:* "Autobiographical Study, An"; Freud, Ernst; German romanticism and psychoanalysis; *Interpretation of Dreams, The*; Reversal into the opposite; Science and psychoanalysis; Vienna General Hospital.

### **Bibliography**

- Bernfeld, Siegfried. (1949). Freud's scientific beginnings. *American Imago*, 6, 163–196.
- Brücke, Ernst Wilhelm von. (1873–1874). *Vorlesungen über Physiologie*. Vienna: Wilhelm Braumüller.
- Jones, Ernest. (1953). *Sigmund Freud: Life and work*. London: Hogarth Press.
- Lesky, Erna. (1965). *Die Wiener medizinische schule. 19 Jahrhundert*. Graz-Köln: Hermann Böhlaus.

## **BRUN, RUDOLF (1885–1969)**

Rudolf Brun was a Swiss physician, a neurologist, holder of the chair of neurology (1940), and member of the Swiss Psychoanalytic Society. He was born March 15, 1885, in Zurich, where he died on January 14, 1969. Brun was born into a family of

Huguenots. His father was a professor of art history in Zurich. As a young man Brun studied in Zurich, completing his medical studies in Zurich, Geneva, and Algiers. Upon leaving school in 1909, he became an assistant to C. von Monakow (clinical work and brain anatomy) at the Zurich Neurological Institute. He completed his training as a general practitioner at the regional hospital in Glarus in 1911–1912 and studied neurology in London and Paris from 1912 to 1913. Under the influence of August Forel, while Brun was still a student, he began studying the behavior of ants, and his research soon attracted the attention of the scientific community. Between 1918 and 1925 he was head physician at the Zurich Neurological Institute.

He was exposed to Freud's writings during his studies but it wasn't until 1916, during his psychological experiments with animals and humans, that he was willing to accept the theory of drives. After 1925 he had his own practice as a neurologist and psychoanalyst. After the makeover of the Swiss Psychoanalytic Society in 1919 he became an associate then a full member, and shared administrative duties with Philipp Sarasin, with whom he completed a training analysis in 1925–1926. Together with Emil Oberholzer he provoked a break between the *Ärztgesellschaft für Psychoanalyse* (Medical Society for Psychoanalysis) and the Swiss Psychoanalytic Society, which he returned to in 1947. He never met Freud in person.

Brun wrote more than 120 publications on entomology, anatomy and pathology, neurology, and psychoanalysis. In the *Allgemeine Neurosenlehre* (1942) he established the position of psychoanalysis in biology. For Brun neuroses were the result of conflicts between the primary (sexual and self-preservative) and secondary (social) instincts. Anxiety is the result of libidinal stasis caused by hormonal activity. Actual neuroses, in Freud's sense, assumed considerable importance for Brun. Because of his biological orientation, Brun reacted violently to beliefs that were based, according to him, on "transcendental idealism," such as *Daseinanalyse* (existential analysis).

KASPAR WEBER

*See also:* Schweizerische Ärztgesellschaft für Psychoanalyse; Switzerland (German-speaking).

**Bibliography**

- Aeschlimann, Jürg. (1890). Rudolf Brun (1885–1969). Leben und werk des zürcher neurologen, psychoanalytikers und entomologen. *Zürcher medizingesch. Abhandlung*, 144, 1980.
- Brun, Rudolf. (1926). "Experimentelle beiträge zur dynamik und ekonomie des triebkonflikts; biologische parallelen zu Freuds trieblehre." *Imago*, 12, 147–170.
- . (1951). *General theory of neuroses; twenty-two lectures on the biology, psychoanalysis and psychohygiene of psychosomatic disorders*. (Bernard Miall, Trans.). New York: International Universities Press.
- . (1956). Mein weg zu Freud. *Schweizer Zeitschrift für Psychologie*, 15, 125–130.
- Minkowski, Mieczyslaw. (1969). Louis Rodolphe Brun, 1885–1969. *Schweizer Archiv. Neurol. Neurochir. Psychiatr.*, 106, 330–334.

**BRUNSWICK, RUTH MACK (1897–1946)**

Ruth Mack Brunswick, a psychoanalyst and psychiatrist, was born in 1897 in Chicago, died January 25, 1946 in New York City.

Ruth Brunswick's father, Judge Julian Mack, became a famous jurist on the U.S. Circuit Court in New York, and also he was known as a prominent Jewish philanthropist. His only daughter Ruth attended Radcliffe College during World War I, and also graduated from Tufts Medical School.

In 1917 she married Dr. Herman Blumgart, who later pursued a successful career as a heart specialist; his brother Leonard had gone to Vienna for a short analysis with Sigmund Freud at the end of World War I. Ruth had completed her psychiatric residency when, at the age of twenty-five, she also went to Freud. Her marriage was already troubled; her husband saw Freud in an unsuccessful effort to salvage the marriage, but Freud evidently decided the relationships was hopeless.

Ruth had fallen in love with a man five years younger than herself, Mark Brunswick, at the time a music student. Ruth was still in analysis with Freud in 1924 when Mark as well began to consult Freud. According to Mark, Freud later admitted that it had been a mistake for Freud and Ruth to have discussed Mark's case in detail.

In the meantime Ruth was teaching at the Vienna Psychoanalytic Training Institute; her specialty was the

psychoses, an area of study that Freud personally avoided. Ruth and Mark were married at the town hall in Vienna in 1928; it was one of the few weddings Freud ever attended. Ruth's access to Freud seemed unique; she came to meals at his apartment, visited him in summers, and was on excellent terms with his children. Ruth was considered a member of Freud's extended family.

Ruth played a special role in mediating between the American analysts and Freud's circle in Vienna. She became an important channel through which wealthy American patients arranged to undergo analyses with Freud. In recognition of her special standing, Ruth became one of the few women who received a ring from Freud. She also played a notable part in supervising Freud's precarious health. Her own patient in analysis, Dr. Max Schur, became appointed Freud's personal physician.

Ruth had health problems, though, that her doctors could not diagnose as unquestionably organic. By 1933 or 1934 at the latest she had developed a serious drug problem, and by 1937 she had become an addict. Her failure to overcome her difficulties was the main reason for Freud's final disappointment in her.

The worst of Ruth's drug addiction occurred in America; her mother died in 1940, her father in 1943. Ruth and Mark were divorced in 1937, and then—against Freud's advice—they re-married in six months. Mark finally divorced her in 1945. Ruth's death in 1946 was the end-result of a pattern of self-destructive behavior. She had been drinking paregoric the way an alcoholic consumes whiskey. Her health was undermined, and the federal authorities had taken note of her drug-taking. She caught pneumonia, recovered, and then died from the combination of too many opiates and a fall in the bathroom; she had hit her head and fractured her skull. The full tragedy was for many years not publicly known. The cloudy circumstances associated with Ruth's medical troubles, and the misfortune of her early death, have obscured both her scientific contributions and her immense personal standing with Freud.

Ruth's central contribution to psychoanalytic thinking had to do with her special concern with the child's earliest relationship to the mother. In 1929 she was one of the first in print to use the term pre-oedipal, and Freud himself adopted it two years later. Otto Rank probably deserves the credit for being the earliest to invoke the concept, but Ruth was tactful

enough to be able to emphasize the importance of the mother in the development of the child, without any revolt on her part against Freud's basic ideas.

She will also be remembered as the Wolf Man's second analyst. In 1926 Freud referred the Wolf Man to Ruth for treatment, paying her a high compliment; he knew that anything she published would become famous in the clinical literature. She wrote an article about the Wolf Man in close collaboration with Freud. She also trained some famous future analysts; she analyzed Muriel Gardiner, Max and Helen Schur, and Robert Fliess, the son of Freud's former friend Wilhelm. Her most famous student was Karl Menninger, who saw her later in the United States.

Ruth had a special talent for manipulating Freud's theoretical concepts, and using them to set forth new ideas of her own. Freud admired her freedom, which helps to account for his partiality toward her. Ruth's analysis with Freud stretched, with some interruptions, from 1922 until 1939. Unwittingly Freud had helped bring about the dependency that it ideally should have been the task of analysis to dissipate. Mark claimed that Freud had first treated Ruth in too close a way, and then tried to be too distant. To insiders within the analytic movement Ruth's death was proof that analytic treatment could not be counted on to prevent human misery. It was left to others, such as Rank and Melanie Klein, to go on to make "pre-oedipal" problems the centers of their respective systems of thought.

Ruth Mack Brunswick was one of the most important women in Freud's immediate circle during the last years of his career; but the tragedy of her life, and the implications it made about her work, has meant that her name is relatively unknown to the general public.

PAUL ROAZEN

*See also:* Addiction; "From the History of an Infantile Neurosis" (Wolf Man); Schur, Max.

### **Bibliography**

Brunswick, Ruth Mack. (1928). A supplement to Freud's history of an infantile neurosis. *International Journal of Psychoanalysis*, 9, 439–76.

———. (1929). The analysis of a case of paranoia (delusions of jealousy). *Journal of Nervous and Mental Disease*, 70, 1–22; 155–178.

———. (1940). The preoedipal phase of the libido development. *Psychoanalytic Quarterly*, 9, 293–319.

## **BULIMIA**

*Bulimia* (from the Greek *boulima*: hunger [*limos*] of an ox [*bous*]), a medical term that has entered common usage, refers to an eating disorder characterized by episodes.

A bulimic episode (a binge) is defined as a fit of frenzied overeating in which an excessive amount of food is consumed in a short time; this episode involves a sense of loss of control. It can occur several times in one day and can completely overwhelm the subject. Bulimia always entails a major and overwhelming event that is convulsive or ritualized, and violent. There is usually an awareness of the pathological nature of this behavior, combined with fear of an inability to avoid it, pleasure, shame, and self-denigration. In addition to bulimia relating to food, there is a form of bulimia that relates to various consumer items (medicines, pathological buying) and to sex.

There are descriptions of bulimic episodes dating from antiquity. Medical dictionaries, particularly in the English language, refer to this disorder from the beginning of the eighteenth century (Blankaart, 1708). Historically, bulimia was predominantly a male disorder and was akin to hyperphagia and gluttony. It was long considered a manifestation of the same order as neurotic symptoms (Janet, 1903); Sigmund Freud referred to it as one of the symptoms of anxiety neurosis and also recorded it as an eating compulsion motivated by a fear of starvation.

As a manifestation of orality in the broad sense, bulimia is generally a form of pathological behavior, a passage to the act that is often impulsive and bypasses any mentalization or psychic material. It then has a defensive function in warding off psychotic disorganization or depressive affects. Karl Abraham mentioned it in his work on melancholia and, in *Fear of Breakdown* (1974), Donald Winnicott described it as a form of defense against the frightening nature of the void.

Bulimia is also associated with the addictions (Radó, 1926). In 1945, Otto Fenichel classified it as a "drugless addiction." Marie-Claire Célérier regards it as a symptom on the boundary between a psychosomatic loss of meaning and a hysterical signifier (1977), while Joyce McDougall describes it in terms of a symptomatic act that substitutes for the undreamt dream.

Bulimia is a widespread phenomenon in Western societies that is both on the increase and more out in the open. It has gradually become a syndrome in its own right—bulimia nervosa—with a separate status from anorexia nervosa and obesity. Wermuth and Russell first established the diagnostic criteria for the bulimic syndrome. In addition to bulimic episodes, these include various strategies for controlling weight and a psychiatric co-morbidity that can be severe (thymic disorders and addictions). These criteria reflect the notions of loss of control, chaotic functioning, inadequate mentalization and relationships of dependency (Jeammet, 1991) that are observed in these patients.

Contemporary discussions of bulimia refer to a complex, multi-faceted disorder that combines eating binges with a range of strategies for maintaining a normal weight, distortions in cognitive functioning and body-image perception, and emotional disturbances (Vindreau, 1991). In the majority of cases, the origins of the disorder are traced back to adolescence and its physiological and psychodynamic transformations. As of 2004, ninety percent of bulimics are women but the bulimia rate is rising among men. Whereas the incidence of the syndrome is three percent in the general population, it rises to seven percent in some adolescent, student, and high-school groups.

The conception of bulimia has developed from a simple compulsive substitution for a repressed sexual drive, into the widely-recognized, contemporary bulimia nervosa. Throughout this development, its definition has closely reflected both sociological and cultural changes and the psychopathological theories that prevailed over time. Above all, both the recourse of acting out through eating behavior, and the perceived need for particular bodily sensations in order to produce a psychic effect (Brusset, 1991), pose questions relating to self-esteem, difficulty in controlling behavior and emotions, narcissistic difficulties, and the quest for identity.

CHRISTINE VINDREAU

See also: Anorexia nervosa; Self representation.

### **Bibliography**

Abraham, Karl. (1924). A short study of the development of the libido, viewed in the light of mental disorders. *Selected papers on Psycho-Analysis* (pp. 418–501). London: Hogarth Press.

Brusset, Bernard. (1991). *Psychopathologie de l'anorexie mentale*. Paris: Dunod.

Célérier, Marie-Claire. (1977). La boulimie compulsive. *Topique*, 18, 95–116.

Fenichel, Otto. (1945). *The psychoanalytic theory of neurosis*. New York: W. W. Norton.

Freud, Sigmund. (1926d). Inhibitions, symptoms and anxiety. *SE*, 20: 75–172.

Igoin, Laurence. (1979). *La boulimie et son infortune*. Paris: Presses Universitaires de France.

Janet, Pierre. (1903). *Les Obsessions et la psychasthénie*. Paris: Alcan.

Jeammet, Phillippe. (1991). Dysrégulations narcissiques et objectales dans la boulimie. In Bernard Brusset and Catherine Couvreur (Eds.), *La boulimie* (pp. 89–104). Paris: Presses Universitaires de France.

McDougall, Joyce. (1974). The psyche-soma and the psychoanalytic process. *International Journal of Psycho-Analysis*, 1, 437–460.

Radó, Sándor. (1926). The psychic effects of intoxicants: an attempt to evolve a psycho-analytical theory of morbid cravings. *International Journal of Psycho-Analysis*, 7, 396–413.

Vindreau, Christine. (1991). La boulimie dans la clinique psychiatrique. In Bernard Brusset and Catherine Couvreur (Eds.), *La boulimie* (pp. 63–79). Paris: Presses Universitaires de France.

Winnicott, Donald W. (1974). Fear of breakdown. *International Journal of Psycho-Analysis*, 1, 103–107.

---

## **BULLITT, WILLIAM C. (1891–1967)**

William C. Bullitt, an American political leader, was born on January 25, 1891, in Philadelphia and died on February 15, 1967, in Paris. With Freud, he was coauthor of “Thomas Woodrow Wilson: A Psychological Study” (1967), and he helped Freud to immigrate to London.

Bullitt was raised in Philadelphia and educated at Yale College in New Haven, Connecticut. He became a prominent figure in American foreign policy. He was a U.S. advisor at the negotiations for the Treaty of Versailles and went to see Lenin on behalf of the U.S. and British delegations. When Bullitt's Russian mission was disavowed, he became bitter toward President Wilson and testified before Senator Henry Cabot Lodge's congressional committee; the secretary of state

was then forced to resign, and Bullitt's evidence also helped defeat the entry of the United States into the League of Nations. In 1933 when President Roosevelt extended diplomatic recognition to the Soviet Union, Bullitt became the first U.S. ambassador. Next Bullitt was ambassador to France from 1936 until the German invasion toppled the French Third Republic. Bullitt performed the role of a roving ambassador all over Europe and possessed a unique set of diplomatic contacts. As ambassador to Austria, Bullitt helped Freud escape Vienna in June 1938 after the Nazis moved into Austria, though what role Bullitt played is not entirely clear.

The stories about Bullitt are colorful. His role in destroying the political career of Undersecretary of State Sumner Welles during the Second World War ruined Bullitt's standing with Roosevelt. Bullitt then attempted to become elected mayor of Philadelphia but was badly beaten. His early disappointment with the Soviets led him to become one of the first cold-war warriors. Bullitt was impulsive and high-handed, mercurial and impressionable—altogether not easy to work with. His brilliance did not prevent his becoming known as intemperate and unstable, even if he could be charming and debonair. In 1948 Bullitt became a Republican and remained on personal terms with some of the great and mighty. But he ended up as an outsider, a political exile.

In 1926 Bullitt published a novel that sold some 150,000 copies. In the late 1920s Bullitt, who had been a patient of Freud's, began a collaborative study with Freud on Wilson, who both authors, for different reasons, hated. It has remained a curiosity how Freud and Bullitt came to write such a polemical assault, using psychoanalytic concepts, in their book on Wilson. It is still unknown who wrote which sections. Part of the scholarly problem has stemmed from Bullitt's fascination with intrigue; Freud privately complained about Bullitt's secretiveness shortly after the manuscript was completed. The book on Wilson may be one of the first efforts at psychological history, but it was so partisan as to have damaged the case for using psychology to understand political leaders.

PAUL ROAZEN

*Work discussed: Thomas Woodrow Wilson, Twenty-eighth President of the United States. A Psychological Study.*

*See also:* Politics and psychoanalysis.

### **Bibliography**

- Bullitt, William C. (1919). *The Bullitt mission to Russia*. New York: Huebsch.
- . (1926). *It's not done*. New York: Harcourt, Brace & World.
- . (1946). *The great globe itself*. New York: Scribner's.
- Freud, Sigmund, and Bullitt, William C. (1967). *Thomas Woodrow Wilson: A psychological study*. Boston: Houghton Mifflin.

---

## **BURGHÖLZLI ASYLUM**

The psychiatric asylum in Burghölzli entered the history of psychoanalysis as a result of the interest shown by Eugen Bleuler and his students (including Carl Gustav Jung) in Freud's theories and their possible application to the mental patients at the asylum. By the mid-nineteenth century there were a number of significant problems with this former clinic. Plans for its reconstruction were made between 1860 and 1864 with the help of Wilhelm Griesinger, a professor of internal medicine at the University of Zurich. The actual work took place between 1864 and 1870. On July 4, 1870, work on the Burghölzli was completed.

The various medical directors of the Burghölzli left their mark on the institution. The first director, Bernhard von Gudden (1870–1872), Gustav Huguenin (1873–1874), and Eduard Hitzig (1875–1879), had a purely biological orientation. Brain pathology and physiology were the focus of their research. It was August Forel (1879–1898) who brought international attention to the clinic. The Burghölzli then served as a bridge between the dynamic approach taken by French psychiatry and the biological orientation of German psychiatry. Forel's celebrated book on hypnotism reflects the importance of the asylum at the time.

Bleuler, the director from 1898 to 1927, who had worked with Jung at the Burghölzli, opened the field to psychoanalytic research and its application in an institutional framework. In 1913 he distanced himself from Freud's work because of personal conflicts and scientific disagreements. The clinic lost its importance as a center of psychoanalytic research and a vehicle for its dissemination. The Burghölzli would never again generate the level of interest in psychoanalysis shown at that time.

The clinic did play a central role in the diffusion of psychoanalysis between 1904 and 1913. It was not only the first clinic in the world where Freud's theories were scientifically tested and his therapeutic methods applied to patients, but also an internationally renowned research center for analytical psychology and therapy. For Freud the Burghölzli served to legitimize his work in the face of the often violent polemics against him. Aside from Jung, Adolf Meyer, Abraham Brill, and Emil Oberholzer, a number of Freud's students, including Karl Abraham, worked at the Burghölzli.

The Burghölzli has become a modern psychiatric clinic with 341 beds and more than 1600 new patients annually (1996). In addition to treating a wide range of conditions, there are ambulatory and semi-ambulatory services for all sectors of psychiatry. It administers its own school of nurses. As a university clinic the Burghölzli has continued to pursue teaching and research activities since its inception. Its research in the field of psychopathology and in the treatment of mental illness has attracted international attention.

BERNARD MINDER

*See also:* Bleuler, Paul Eugen; Switzerland (German-speaking).

### **Bibliography**

Bleuler, M. (1951). Geschichte des Burghölzlis und der psychiatrischen universitätsklinik. *Zürcher Spitalgeschrift*, 2, 377–425.

Psychiatrische Universitätsklinik Burghölzli Zürich. (1970). *1870–1970: Hundert Jahre Festschrift* (pp. 1–87).

---

**BURLINGHAM-ROSENFELD SCHULE.** *See* Hietzing Schule/Burlingham-Rosenfeld School

---

### **BURLINGHAM-TIFFANY, DOROTHY (1891–1979)**

Psychoanalyst Dorothy Burlingham was born in New York on October 11, 1891, and died in London on November 19, 1979. She was closely associated with Anna Freud and her personal history is intimately linked to the psychoanalytic movement.

Burlingham's grandfather, Charles Tiffany, was the founder of the famous jewelry store, Tiffany & Co., and her father was Louis Comfort Tiffany, the celebrated painter and artisan. In 1914 Dorothy wed a surgeon, Robert Burlingham, but their marriage was soon troubled, in great part due to his phobias and episodes of manic-depressive illness. The couple separated in 1921.

After moving to Vienna with her four children in 1925, Dorothy began analysis with Theodore Reik. Her life subsequently became entwined with that of the Freuds, as Anna Freud took her children into treatment. In spite of becoming Anna's close friend, Dorothy undertook a second analysis with Sigmund Freud. The situation was loaded with a series of fantastically complex entanglements. Ernst, son of Sophie Halberstadt (Freud's daughter, who died in 1920) was best friends with Bob, Dorothy Burlingham's son. Both attended the Hietzing School, which had been founded in 1927 by Anna and Dorothy, together with Eva Rosenfeld, with a view to raising children from their milieu in a "psychoanalytic" fashion.

Burlingham fled Vienna upon the Nazi invasion in 1938, and after a short stay in the United States, and following Freud's death in London, settled close to Anna Freud near Maresfield Gardens. During the war, Anna and Dorothy founded and managed together the Hampstead War Nurseries, where they undertook historic research which they reported on in *Infants Without Families* (1943). Their collaboration led them to a groundbreaking description of infantile depression and an important advance in psychoanalytic psychopathology.

Their friendship was profound, and Dorothy's death powerfully affected Anna. She continued to care for her friend's children with such emotional investment that it provides an interesting perspective on the mechanism of "altruistic surrender" that she had once described.

In addition to her work with Anna Freud, Burlingham wrote several studies of blind children and, in addition, undertook early research on the psychology of identical twins.

BERNARD GOLSE

*See also:* Abandonment; Bergasse 19, Wien IX; Freud, Anna; Hampstead Clinic; Latent; Lehrinstitut der Wiener psychoanalytischen Vereinigung.

### **Bibliography**

- Burlingham, Dorothy. (1952). *Twins: A study of three pairs of identical twins*. London: Imago Publishing.
- Burlingham, Michael John. (1989). *The last Tiffany: A biography of Dorothy Tiffany Burlingham*. New York: Atheneum.
- Freud, Anna, and Burlingham, Dorothy. (1943). *Infants without families*. London: G. Allen and Unwin.

---

### **BURROW, TRIGANT (1875–1950)**

A forgotten American psychoanalyst and pioneer of group analysis, Trigant Burrow was born in Norfolk, Virginia, on September 17, 1875, and he died on May 25, 1950, in Westport, Connecticut.

Burrow was the fourth child of John and Anastasia Burrow; his father was Protestant, his mother, a Catholic. His father was a scientifically-minded wholesale pharmacist. At the beginning of his higher education, Burrow attended Fordham University, where the dogmas of the Catholic church began to lose their significance for him. Following his graduation in 1895, he entered the medical school at the University of Virginia, 1899. One year was spent in post-graduate study of biology, one year touring Europe where he attended the psychiatric clinic in Vienna of Professor Wagner-Jarureg. Returning to America he spent three years in the study of experimental psychology, for which he received a PhD in 1909 based on his study of the process of attention. This was a subject that he pursued later in his psychoanalytic career when his interest turned back to physiological processes.

Burrow began to work with the Swiss psychiatrist Adolf Meyer at the New York State Psychiatric Institute, and was introduced to Freud and Jung who were in America for the Clark University Lectures. Burrow was immediately determined to study psychoanalysis and at the age of thirty-four moved with his family to Zurich for a year's analysis with Carl Gustav Jung. This involved considerable financial hardship, but he greatly valued his experience there. This was at the time when Freud and Jung were still closely associated. Burrow was proud of the fact that he was the first American-born person to study psychoanalysis in Europe. In 1910, he returned to Baltimore to work with Meyer at Johns Hopkins University. In 1911, he joined

Ernest Jones and others to found the American Psychoanalytic Association (APA).

Between 1911 and 1918, Burrow published eighteen papers on psychoanalysis. His originality is shown in papers written from 1914 onwards. They anticipate much later work in infant development: He writes of the “preconscious” experience of the infant, which remains part of the psyche throughout life. He does not mean Freud’s preconscious, that which is accessible to consciousness, but that which is prior to consciousness, when the infant is at one with the mother. For the infant the mother is the infant’s love subject, not love object, and the preconscious mode is a feeling that goes out of the infant’s primary identification with the mother. In the womb there is a primary physiological unity between infant and mother and a psychological union, a pre-objectless state. These manifest in later life as states of quietude and self-possession. The break in physiological and psychological union with the mother through birth is restored when the infant nourishes at the breast, experiencing a semblance of organic unity, completion and satisfaction. This anticipates much later work, of Margaret Mahler on separate individuation, and Kohut and his self-object theory. Burrow saw resemblances between his ideas and those of Ferenczi.

Burrow’s move into group analysis was preceded by his accepting the challenge of one of his analysands, Clarence Shields, to change places with him. Accepting the role of patient, Burrow was immediately impressed with the nature of his own resistances and an appreciation of the social forces at work in the analytic situation. Soon he extended his study to the group situation where he, his colleagues and pupils entered into an intensive study of group processes. Burrow’s emphasis was on the analysis of the “here and now”: “Group analysis or social analysis is the analysis of the immediate group in the immediate moment.” Every member of the group, including the analyst, is both an observer of his own processes and is observed by all the other members of the group. The analyst does not have a privileged position.

Throughout his life Burrow thought of himself as being a psychoanalyst and a Freudian. He believed that he was extending the relational aspects that were already present in Freud and in correspondence tried to persuade Freud of the validity of his work with groups. He failed in this and in 1926 Freud wrote: “As



far as the group is concerned an analytic influence is impossible.” Some of Burrow’s attempts to have his papers published in the *Internationale Zeitschrift* were blocked by Paul Federn and Sandor Rado.

Burrow saw the “I-persona” that is each individual’s self-image as being derived from social influences. From infancy onward, society imposes concepts of what it is to be good and bad and each internalizes these social images and adapts to the demands of society. Thus individuals are divided from the primary organismic unity with society, the world; in group analysis individuals become aware of the strength of the social self-image and can begin to overcome its influence and to reunite with the group as a whole, with the wider society.

Between 1925 and 1928, Burrow published a further thirteen papers, nine of which were given to the APA. He tried to persuade his fellow analysts that the neurotic structures of the individual are replicated in the neurotic structures of society: society is hysterical too, has its own elaborate system of defense mechanisms. He was appointed president of the American Psychoanalytic Society in 1925, but continued his critique of psychoanalysts. “We need to rid ourselves of the idea that the neurotic individual is sick and that the psychopathologists are well. We need to accept a more liberal societal viewpoint that permits us to recognize without protest that the individual neurotic is in many respects not more sick than we ourselves.” Burrow insisted that consensual observation is synonymous with scientific method and therefore it is only in the group “laboratory” situation that sexual fantasies, family conflicts, and the social mask become observable. At the annual meeting of the APA in 1925, he said that neurosis is social and that a social neurosis can be met only through a social analysis.

In 1933, when the APA reorganized itself, Burrow was asked to resign his membership. He accepted this with dignity and tried to remain on friendly terms with many of his former colleagues.

In the last phase of his work his interest turned back to the process of attention. Through physiological research and self-observation he described the process

by which each individual experiences the tensions of being a member of society: that is, by muscular tension in the ocular and forehead regions, which he called “ditution.” Through training it is possible to identify and to give up this process and to experience “cotention,” an experience that restores the sense of unity with the social.

Burrow and his followers formed the Lifwynn Institute (Foundation for laboratory research in analytic and social psychiatry) in Westport, Connecticut, which has carried on his work.

Burrow’s psychoanalytic and group analytic work anticipated the findings of much later workers. Sigmund Henrich Foulkes, the founder of group analysis, acknowledges his influence, having read his work in 1926. Many of the techniques of group therapy and of the encounter group movement originate from Burrow and his group laboratory. He wrote seven books and seventy articles, and had this comment: “Psychoanalysis is not the study of neurosis: it is a neurosis,” but for Freud he was a “muddled bubbler” (letter to Sándor Rádo, September 30, 1925).

MALCOLM PINES

*See also:* Group analysis; Group psychotherapies.

### **Bibliography**

- Burrow, Trigant. (1927). The group method of analysis. *Psychoanalytic Review*, 14, 268–280.
- . (1949). *The neurosis of man: An introduction to the science of human behaviour*. New York: Harcourt, Brace and World.
- . (1958). *A search for man’s sanity. The selected letters of Trigant Burrow, with biographical notes*. New York: Oxford University Press.
- Syz, Hans. (1963). Reflections on group or phylo-analysis. *Acta Psychotherapeutica et Psychosomatica*, 2, 37–55.



1



2



3

**one:** Karl Abraham (1877–1925), German psychoanalyst and doctor. Abraham was a close collaborator of Freud and founder of the Berliner Psychoanalytische Vereinigung (Berlin Psychoanalytic Society). *Public Domain. Courtesy of the New York Psychoanalytic Institute and Society.* **two:** Alfred Adler (1870–1937), American psychiatrist and creator of Individual Psychology, a form of psychotherapy. *Getty Images. Reproduced by permission.* **three:** Franz Alexander (1891–1964), Hungarian doctor, psychoanalyst, and founder of the Chicago Psychoanalytic Institute (shown here with A. A. Brill, left). *Courtesy of the New York Psychoanalytic Institute and Society. Reproduced by permission.*



**four:** Didier Anzieu (1923–1999), French psychoanalyst and professor of psychology. Anzieu developed the notion of "skin-ego." *Courtesy of the International Association for the History of Psychoanalysis. Reproduced by permission.* **five:** Piera Aulagnier (1923–1990), French physician, psychiatrist, and psychoanalyst. Aulagnier was the founder of the Quatrième groupe. *Courtesy of the International Association for the History of Psychoanalysis. Reproduced by permission.* **six:** Robert Bak (1908–1974), Hungarian psychiatrist and psychoanalyst. Bak was president of the New York Psychoanalytic Society from 1957 to 1959. *Photo by Ethel Pries. Courtesy of the New York Psychoanalytic Institute and Society. Reproduced by permission.* **seven:** Edmund Bergler (1899–1962), Austrian psychoanalyst. Bergler was director of Freud's clinic in Vienna from 1933 to 1938, and the author of *The Basic Neurosis*. *Courtesy of the New York Psychoanalytic Institute and Society. Reproduced by permission.*





8



9

**eight:** Siegfried Bernfeld (1892–1953), Austrian philosopher and psychoanalyst. Freud considered Bernfeld to be one of his most gifted students. *Public Domain. Courtesy of the New York Psychoanalytic Institute and Society.* **nine:** Grete Lehner Bibring (1899–1977), Austrian doctor and psychoanalyst. Bibring made important contributions to the field of women's psychology, especially in her research on pregnancy and mother-child relationships. *Archives, Boston Psychoanalytic Society and Institute (BPSI). Reproduced by permission.* **ten:** Peter Blos, Sr. (1904–1997), German child psychoanalyst and founder of the Association of Child Psychoanalysis. *Courtesy of the New York Psychoanalytic Institute and Society. Reproduced by permission.* **eleven:** Eugen Bleuler (1857–1939), Swiss professor of medicine. Bleuler was instrumental in opening the European medical community to psychoanalysis, despite his own tentative acceptance of Freud's work. *Courtesy of the New York Psychoanalytic Institute and Society. Reproduced by permission.*

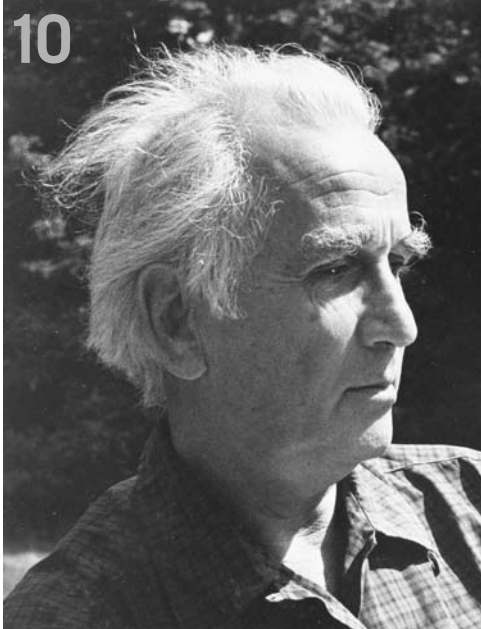

10

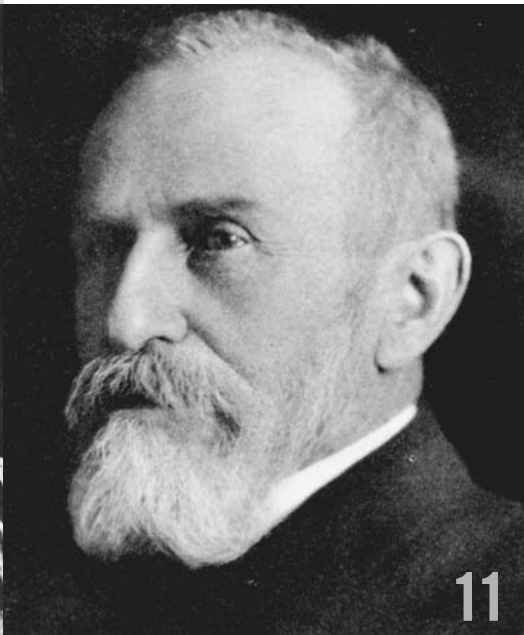

11

**twelve:** Berta Bornstein (1899–1971), child psychoanalyst. Bornstein was an innovator in the field of child psychoanalysis. *Photo by Ina Furst. Courtesy of the New York Psychoanalytic Institute and Society. Reproduced by permission.* **thirteen:** Josef Breuer (1842–1925), Austrian physician. Breuer developed the "cathartic method" in collaboration with Freud as a result of Freud's treatment of "Anna O." © Corbis. *Reproduced by permission.* **fourteen:** A. A. (Abraham Arden) Brill (1874–1948), American psychiatrist and psychoanalyst, first practicing psychoanalyst in the United States and one of the founders of the New York Psychoanalytic Society. *Courtesy of the New York Psychoanalytic Institute and Society. Reproduced by permission.* **fifteen:** Jean-Martin Charcot (1825–1893), French physician. Charcot was the first to use hypnosis to treat hysteria. *Public Domain. Courtesy of the New York Psychoanalytic Institute and Society.*



12



13



14



15

**sixteen:** Clark University: Group photograph taken during Freud's visit in 1909, his only visit to the United States. Back row from left: A. A. Brill, Ernest Jones, Sandor Ferenczi; Front row from left: Freud, G. Stanley Hall, Carl G. Jung. © Corbis/Bettmann. Reproduced by permission. **seventeen:** Clark University Psychological Conference attendees, September 1909. © Corbis. Reproduced by permission.



16



17

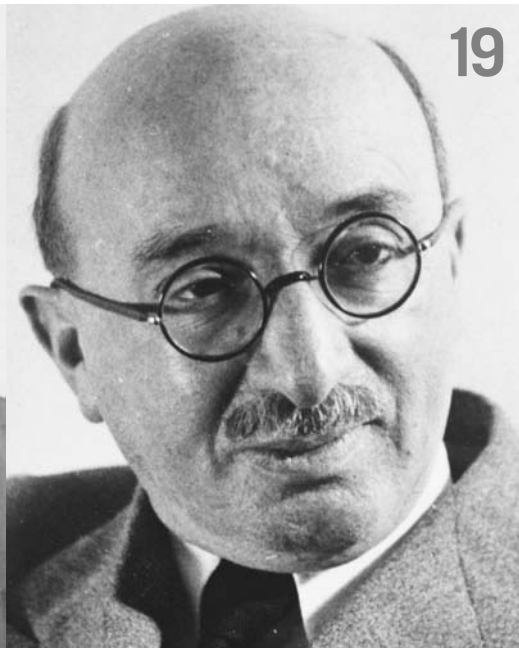

**eighteen:** Helene Deutsch (1884–1982), American psychoanalyst. Deutsch was the first to write a book on the psychology of women. *Archives, Boston Psychoanalytic Society and Institute (BPSI). Reproduced by permission.* **nineteen:** Max Eitingon (1881–1943), Russian physician, psychiatrist, and psychoanalyst. Eitingon was the founder of the Palestine Psychoanalytic Association in 1934. *Courtesy of the New York Psychoanalytic Institute and Society. Reproduced by permission.* **twenty:** Erik Erikson (1902–1994), German-born child psychoanalyst famous for his theory of the "Eight Stages of Psychosocial Development." © Ted Streshinsky/Corbis. *Reproduced by permission.* **twenty-one:** Jean Favreau (1919–1993), French psychiatrist and psychoanalyst. Favreau served as head physician of the Centre de consultations et de traitements psychanalytiques (Center for Psychoanalytic Consultations and Treatment) from 1958 to 1989. *Courtesy of the International Association for the History of Psychoanalysis. Reproduced by permission.*





22



23



24

**twenty-two:** Sándor Ferenczi (1873–1933), Hungarian neurologist and psychoanalyst. Ferenczi developed the "active technique" of analysis and pioneered work on the concept of introjection. *Public Domain. Courtesy of the New York Psychoanalytic Institute and Society.*

**twenty-three:** Anna Freud (1895–1982), Freud's youngest child and a psychoanalyst. She was a pioneer in child analysis. *Archives of the History of American Psychology. Reproduced by permission.*

**twenty-four:** Sigmund Freud (1856–1939), Austrian physician, psychiatrist, and founder of psychoanalysis. Freud was also a prolific writer, whose work is appreciated for its artistry as well as its content. *The Library of Congress. Reproduced by permission.*

**twenty-five:** Freud with his father Jakob (1815–1896), January 1865. *Photo by Hulton Archive/Getty Images. Reproduced by permission.*

25

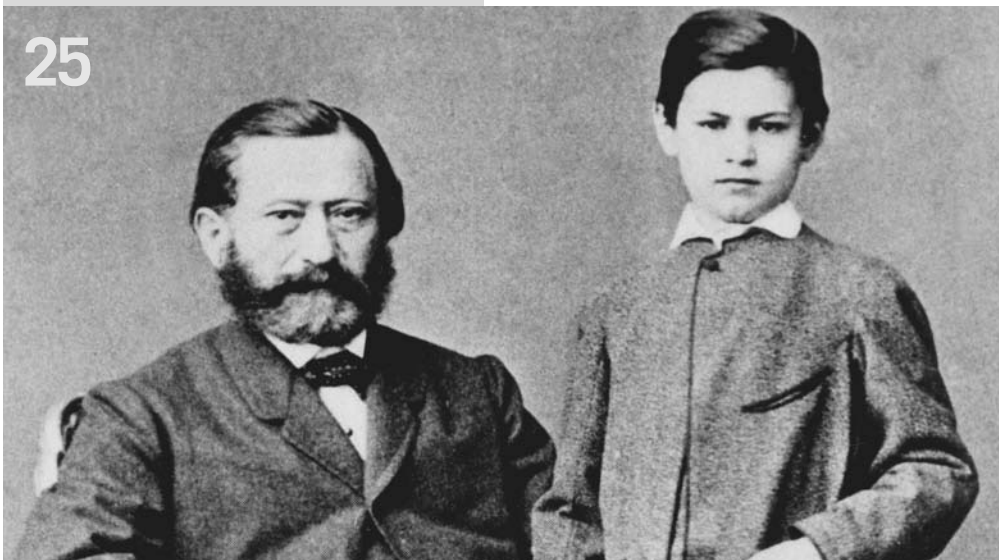



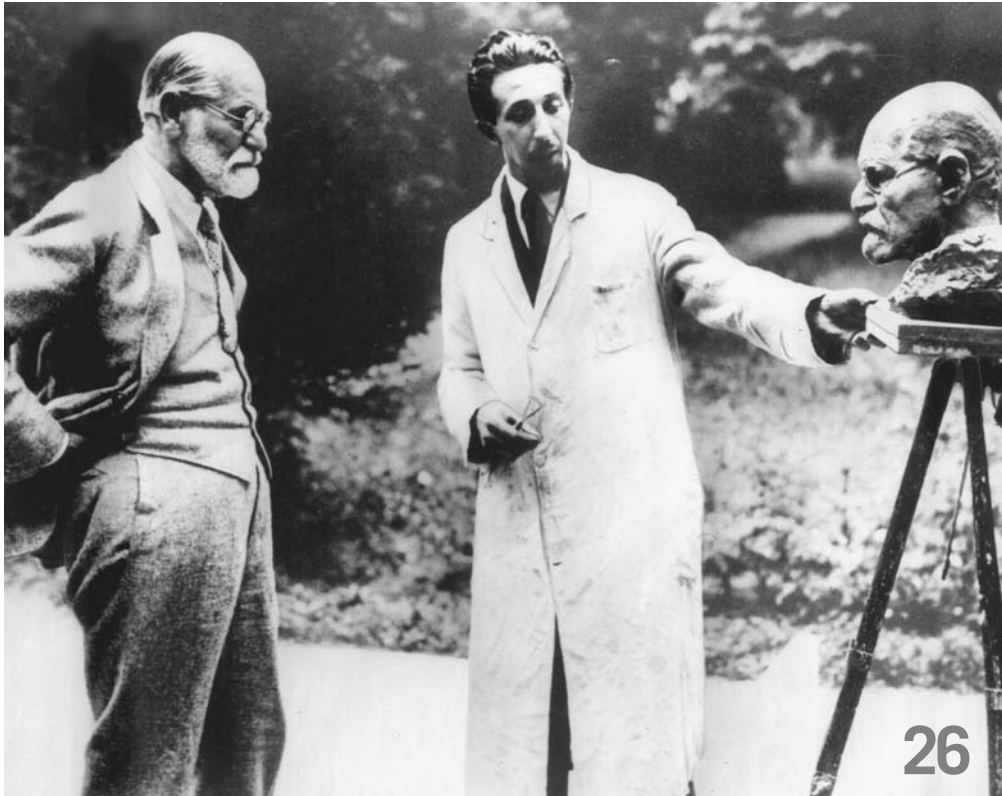

26



27



28

**twenty-six:** Freud and sculptor O. Nemen with bust of Freud, 1931. *AP/Wide World Photo. Reproduced by permission.* **twenty-seven:** Freud, his wife Martha and their daughter Anna, 1899. *The Library of Congress. Reproduced by permission.* **twenty-eight:** Erich Fromm (1900–1980), German psychoanalyst. Fromm, a Marxist, was very interested in connecting Marxism and psychoanalysis. He was also the founder of the Mexican Psychoanalytic Institute. *Archive Photos, Inc. Reproduced by permission.*

# C C

## CÄCILIE M., CASE OF

“Frau Cäcilie M.” is the pseudonym given by Sigmund Freud to Anna von Lieben (her identity was discovered by Peter Swales [1986]), a patient Freud described only briefly in the *Studies on Hysteria* (1895d). Born Baronne von Todesco in 1847 into a rich Jewish family living in Vienna, she was treated for several years by a number of celebrated physicians, including Jean Martin Charcot, before being sent to Freud, in 1887 or early 1888, by either Josef Breuer or Rudolf Chrobak.

Freud treated Cäcilie M. until November 1893. Although the case receives scant attention in the *Studies on Hysteria* and in his correspondence with Wilhelm Fliess, it was significant. “This was shown in the case of another patient, Frau Cäcilie M., whom I got to know far more thoroughly than any of the other patients mentioned in these studies. I collected from her very numerous and convincing proofs of the existence of a psychical mechanism of hysterical phenomenon such as I have put forward above. Personal considerations unfortunately make it impossible for me to give a detailed case history of this patient, though I shall have occasion to refer to it from time to time” (1895d, p. 69)

Von Lieben had been suffering sporadically from a facial neuralgia when she became Freud’s patient. In 1925 Freud wrote that she had been sent to him “because no one knew what to do with her” (1925d, p. 18) after thirty years of hysterical disturbances, absences, and pain, which, against a background of depression and feelings of low self-esteem, had led to a serious morphine dependence.

She was nine years older than Freud and was forty-one when he met her. Through her mother, born Gomperz, she found herself involved in a family that

played an important role in Freud’s life. Apparently, she met him prior to a trip to Paris, since a letter from Charcot dated September 26, 1888, makes reference to a consultation with the Parisian master, a consultation that does not appear to have been the first:

“I am very grateful to you for the details you have provided concerning the state of Madame de L. Your difficult and extensive analysis of the varied and complex physico-psychic phenomena she presents show that you have grown attached to this interesting person just as we ourselves grew attached during her stay in Paris. I am in complete agreement with you on the method to be followed at this time. Moral treatment must play the principal role and, from the point of view of medication, there is absolutely nothing to say in general. One must naturally act following the indications of the moment. With respect to the diarrhea of which she complains and sometimes lasts two or three weeks, wouldn’t it be appropriate to see how she responded to a few centigrams of silver nitrate taken internally? . . . But, I repeat, it is on her psyche that we must act, as you perfectly understood and it is in this way that we can be useful in this case. Moreover, compared to what she was before, the Mademoiselle de L. of today is much better in all respects. She is, as she herself recognizes, up to a certain point prepared to struggle for her life, something she was not willing to do previously” (de Mijolla, 1988).

Because she was difficult to hypnotize, he accompanied her in July 1889 to Nancy to see Hippolyte Bernheim, who failed to obtain the desired results. This setback was part of what led Freud to abandon hypnosis and suggestion, which nonetheless had enabled his patient “to lead a tolerable existence” (1925d, p. 18).

According to Freud, she presented a “hysterical psychosis of denial,” with broad periods of amnesia regarding the traumatic moments she had lived through. Toward the end of 1889 “an old memory suddenly broke in upon her clear and tangible and with all the freshness of a new sensation” and a “cathartic cure” could be undertaken, not however without “accompanied by the acutest suffering and the return of all the symptoms she had ever had” (1895d, p. 70n). It took three years of “chimney sweeping” to pay back “the old debts” (p. 70n), with alternating periods of irritability, depression, and anxiety.

Cécilie influenced Freud as well; she taught him the mechanism of “hysterical conversion” associated with a process of symbolization. Her trigeminal neuralgia, for example, appeared to be determined by a “traumatic scene” during which her husband had made a remark to her that she re-experienced during treatment, saying “It was like a slap in the face” (1895d, p. 178).

She had an intuition of a future state that led her to remark, “It’s a long time since I’ve been frightened of witches at night,” the night before she experienced this fear. For Freud, “On each occasion what was already present as a finished product in the unconscious was beginning to show through indistinctly. This idea, which emerged as a sudden notion, was worked over by the unsuspecting ‘official’ consciousness (to use Charcot’s term) into a feeling of satisfaction, which swiftly and invariably turned out to be unjustified. Frau Cécilie, who was a highly intelligent woman, to whom I am indebted, for much help in gaining an understanding of hysterical symptoms, herself pointed out to me that events of this kind may have given rise to superstitions about the danger of being boastful or of anticipating evils” (1895d, p. 76n).

It is known that Freud saw her as often as twice a day (like Emmy von N.), even during his vacations, which earned her the name of Prima Donna in a letter to Fliess dated July 12, 1892. These two wealthy patients provided the bulk of his income for several months during 1889, but it was for other reasons that he was disappointed when Anna terminated her cure in 1893. On November 27, 1893 he complained in a letter to Wilhelm Fliess “My head misses the usual overwork since I lost [Cécilie M.]” (letter to Wilhelm Fliess, November 27, 1893, in 1985, p.61). On February 8, 1897, he returned to the subject, “If you knew... [Cécilie M.], you would not doubt for a moment that only this woman could have been my teacher” (1985, p. 229).

Peter Swales, after a long investigation, has written a fairly complete biography of this patient, who was a member of Vienna’s aristocracy and an active participant in Jewish intellectual life. It is easy to understand the extent to which she could have influenced Freud, who also saw in her a refutation of the theories of Pierre Janet on the congenital deficiencies of the mental state of hysterics. She died on October 31, 1900, of a heart attack.

ALAIN DE MIJOLLA

See also: *Studies on Hysteria*.

### Bibliography

- Freud, Sigmund, and Breuer, Josef. (1895d). *Studies in hysteria*, SE, 2: 48–106.
- Freud, Sigmund. (1925d). An autobiographical study, SE, 20: 1–74.
- Freud, Sigmund, and Fliess, Wilhelm. (1985). *The complete letters of Sigmund Freud to Wilhelm Fliess: 1887-1904* (Jeffrey Moussaieff Masson, Ed. and Trans.). Cambridge, MA and London: The Belknap Press of the Harvard University Press.
- Mijolla, Alain de. (1988). Les lettres de Jean-Martin Charcot à Sigmund Freud, 1886–1893. Le crépuscule d’un dieu. *Revue française de psychanalyse*, LII, 3, p. 703–726.
- Swales, Peter. (1986). Freud, his teacher, and the birth of psychoanalysis. In Paul E. Stepansky (Ed.), *Freud: Appraisals and reappraisals* (pp. 3–82). New Jersey: The Analytic Press, 1986.

---

## CAHIERS CONFRONTATION, LES

Under the editorial direction of René Major, *Les Cahiers Confrontation* was the eponymous publication that broadened the audience for the discussions and debates that constituted the well-known series of seminars, *Confrontation*. In articles that asked probing and provocative questions outside the usual bounds of various disciplines, each issue of the biannual publication (1979-1989), which featured original cover art with drawings by Valério Adami, helped to extend psychoanalytic investigation into the broader realms of culture and contemporary thought.

Indeed, *Les Cahiers* played a precursor role in creating what became known as the “Confrontation effect” that impacted a number of associations and publications of

analysts, who appealed to related disciplines in pursuing and developing psychoanalytic research.

Some themes addressed in *Les Cahiers* directly related to issues in psychoanalytic practice, theory, or institutions. Examples include *L'Etat cellulaire* (The cellular state), *Les machines analytiques* (Analytic machines), *La sexualité masculine* (Male sexuality), *Les fantômes de la psychanalyse* (The ghosts of psychoanalysis), *Télépathie* (Telepathy), *L'Etat freudien* (The Freudian state), *L'Interprétation* (Interpretation), and *La logique freudienne* (Freudian logic).

*Les Cahiers* also examined aspects of art and literature, in articles such as *Art et désordre* (Art and disorder), *America Latina* (Latin America), *Correspondances* (Correspondences), *Palimpsestes* (Palimpsests), and *Déchiffrement* (Deciphering). Philosophical issues included Derrida and *Après le sujet Qui vient* (After the subject, who?); religion was the focus of *Conversion* (Conversion) and *La religion en effet* (The impact of religion). Articles from these issues were frequently cited in numerous works both in France and abroad, by among others, Alain Badiou, Etienne Balibar, Alan Bass, Jean Baudrillard, Antoine Berman, Maurice Blanchot, Michel de Certeau, Philippe Lacoue-Labarthe and Jean-Luc Nancy, Jean-François Lyotard, Charles Malamoud, Guy Rosolato, René Thom, Maria Torok, Marc-Alain Ouaknin, Serge Viderman, Paul Virilio, Samuel Weber, and influenced the texts of famous writers Julio Cortazar, Carlos Fuentes, Gabriel Garcia Marquez, and Octavio Paz.

The publication of *Les Cahiers Confrontation* marked a fruitful period, during which psychoanalysis opened up to and participated in the important cultural debates of the times. Issues included feminism and phallogocentrism, the role of psychoanalytic institutions with their inherent contradictions and aporias, and politics and the putative end of ideology. A variety of issues anticipated questions that would subsequently gather currency, including the return of religion and the contribution of Lacanian thought to rethinking Freudian orthopraxis.

*Editions Confrontation* represented a publishing outcome of *Les Cahiers* that enabled major communications from the seminars to find their way rapidly into print. Numerous works published under these auspices are still in demand. *L'Inanalysé* (Un-analyzed) discussed analytic theory in terms of a sort of coded residue of what is unthought and unthought-out in

established psychoanalysis; contributions to *Le corps et le politique* (The body and politics) played a role in dissolution of the Ecole freudienne de Paris. *Le lien social* (Social cohesion) raised issues as to the social nature of analysis. *Géopsychanalyse* remains famous today for questioning why analysts at an International Psychoanalytical Association congress in New York failed to take a principled stand regarding the role of analysis in human rights violations during the Argentinean military dictatorship (1976-1984).

Other publications included *Affranchissement* (Franking/emancipation) in which, regarding the publication of *La carte postale*, the fundamental question of the divisibility (or its opposite) of the letter is discussed, as well as Derridian reading of Freud's *Beyond the Pleasure Principle*. The texts that comprise *Psychoanalyse et apocalypse* (Psychoanalysis and apocalypse) appeared in the context of the dissolution of the Ecole Freudienne de Paris and the disintegration of the Lacanian movement. In *Les Années brunes* (The dark years), German analysts discussed the compromises made in the name of psychoanalysis under the Third Reich.

CHANTAL TALAGRAND

### **Bibliography**

*Les Cahiers Confrontation* 1-20 (1979–1989).

---

## **CANADA**

Although Ernest Jones chose Toronto as the city from which he would undertake his campaign to institutionalize psychoanalysis in North America, Montreal is the city where it got its start in Canada. In 1957 the International Psychoanalytic Association (IPA) officially recognized the Canadian Psychoanalytic Society (CPS). Although English and French were the society's two official languages, exchanges and teaching activities took place almost exclusively in English until 1969, when the Société Psychanalytique de Montréal (Montreal Psychoanalytic Society) was established. Only after the Canadian Psychoanalytic Society created a French section, along with other English sections, did it institute a training program in French. Mirroring the relationship between Quebec and the remainder of Canada, the Société Psychanalytique de

Montréal and the English-language sections were two isolated entities that continued to question the reasons for their cohabitation.

In 1908 Ernest Jones established himself in Canada as a neuropathologist at the Toronto Lunatic Asylum. He remained there until 1913, when he returned to Europe, after having contributed to the foundation of psychoanalysis in the United States. However, no permanent organization was established in Canada as a result of his presence there, and it would take another forty years before psychoanalysis gained a foothold in the country.

After being established in Montreal, a large metropolis of psychoanalysis in Canada is the result of a paradox that is as strange as it is revelatory of the unique character of the country: an anti-Franco Spanish refugee, Miguel Prados, formed an alliance with a French-Canadian priest, the Dominican Noël Mailloux. Beginning in the spring of 1945, four interns from the Allan Memorial Institute of McGill University, founded by Dr. Ewen Cameron in 1944 and affiliated with the Royal Victoria Hospital, began meeting at the home of Dr. Prados, who had obtained a position at the Neurological Institute in the early 1940s. There they discussed clinical cases and studied what they referred to as “Freudian doctrine.”

In early 1946 they decided to form a group known as the Cercle Psychanalytique de Montréal (Montreal Psychoanalytic Circle). At this time Prados had only undertaken a self-analysis and was not affiliated with any psychoanalytic association. In 1948 Father Mailloux, who had founded the Institute of Psychology at the University of Montreal at the same time as Cameron was founding the Allan Memorial Institute, joined the group, which grew considerably from this time on. The number of members grew to forty, with as many guests invited to meetings. From New York they invited Sándor Lorand, Edith Jacobson, Bertrand D. Lewin, Phyllis Greenacre, Rudolph Loewenstein, Rene Spitz, George Gero, Charles Fisher, and Kaufman; from Detroit, Leo Bartemeir and Richard and Editha Sterbas; from Boston, Eduard Lindeman and Edward and Grete Bibring.

Although the circle certainly helped to spread psychoanalysis, it did not promote the training of Canadian psychoanalysts. Forced to seek training at institutions in the United States, these candidates had little inclination to return to Canada. In 1948, with the

help of the Lady Davis Foundation and Father Mailloux, Professor Théo Chentrier, a member of the Société Psychanalytique de Paris (Paris Psychoanalytic Society), became the first psychoanalyst to immigrate to Canada. He was appointed professor at the University of Montreal and joined the Cercle Psychanalytique, of which he later became an enthusiastic and loyal director. Between 1948 and 1950 the circle was very active and held semimonthly meetings, along with weekly seminars on clinical practice and theory.

In 1950 Dr. Eric Wittkower of the British Psychoanalytic Society came to the Allan Memorial Institute. Then in 1951 Georges Zavitzianos, a member of the Société Psychanalytique de Paris, immigrated to Montreal. In the autumn of that same year, Dr. Alastair MacLeod, of the British Psychoanalytic Society, was hired by the psychiatry department of McGill University. Finally, in September 1952 Dr. Bruce Ruddick, who had just completed his training at the New York Institute, returned to Montreal.

With the arrival of these four psychoanalysts, all members of organizations recognized by the IPA, members of the circle felt that it was time to seek official status. Since recognition could only be granted to members who belonged to an affiliate group, Théo Chentrier, Alastair MacLeod, Miguel Prados, Bruce Ruddick, Eric Wittkower, and Georges Zavitzianos formed a study group and applied to the IPA, hoping to be recognized at the 1951 congress. As the bylaws required a recommendation from an affiliate group, they turned to the Detroit Psychoanalytic Society, which was familiar with the circle, to obtain recognition as an independent organization and affiliate of the American Psychoanalytic Association (APA). Since the APA had recently discredited the Detroit training program, it was suggested to the study group that they contact the Boston Psychoanalytic Society, which they never did. At the end of September 1951, the group learned that during the congress in Amsterdam, its request had been referred to the office of professional standards of the American Psychoanalytic Association. Although the professional-standards committee may have supported the request, the APA's official response was that the time was not right: a member of the group was an analyst but not a physician, and the Canadians were planning to admit lay analysts.

Faced with this situation, the study group withdrew its request to the American association and turned to the British Psychoanalytic Society, which granted them

membership after no more than a few weeks of deliberation. As a result, in March 1952 the Canadian Society of Psychoanalysts became an affiliate of the British Psychoanalytic Society. Chentrier was the president, and MacLeod the secretary. The response from the APA was immediate. They let it be known that the Marienbad Agreement of the 1936 IPA congress gave them exclusive control over all of North America. The British Psychoanalytic Society replied that since Canada was part of the British empire, it was only fair that it serve as sponsor in this case. The Americans rejected out of hand a compromise that would have involved joint sponsorship from both associations. In July 1952, after lengthy negotiations, the British Psychoanalytic Society indicated that it would not oppose an agreement with the APA if this solution would help to establish in Canada a psychoanalytic society recognized by the IPA. To facilitate negotiations with the Americans, Chentrier, who was not a physician, decided in August 1952 to give up the presidency of the Canadian Society of Psychoanalysts. MacLeod became president, and Ruddick secretary. After being dissolved on October 17, 1953, the society was replaced by the Canadian Society for Psychoanalysis. But more important, in October 1952 Prados proposed dissolving the Montreal Psychoanalytic Circle because he was convinced that the Americans confused it with the Canadian Society of Psychoanalysts, which consisted exclusively of member analysts. These concessions turned out to be pointless because the Americans never granted affiliate status to the Canadian group.

On October 17, 1953, the group was officially formed as the Canadian Psychoanalytic Society. In December 1953 the group withdrew its request for membership in the APA and reaffirmed its membership in the British Psychoanalytic Society, which had never been abandoned. Because Canada is bicultural, with equal weight given to French and English, it was decided that the society would officially be bilingual. During the summer of 1953, Dr. Jean-Baptiste Boulanger, his wife Françoise, and Dr. J. P. Labrecque, all of whom were trained by the Société Psychanalytique de Paris, became members of the study group. The following year, Dr. W. Clifford M. Scott, a Canadian psychoanalyst who had become president of the British Psychoanalytic Society; Drs. Hans and Friedl Aufreiter of the Vienna Psychoanalytic Society; and André Lussier, who was completing his training at the London Institute, joined the new organization. Initially incorporated in Quebec by the lieutenant-governor of the

province in 1955, it became incorporated under Canadian federal law on April 3, 1967. And with the sponsorship of the British Psychoanalytic Society, it became officially recognized as a member of the International Psychoanalytic Association on July 31, 1957, during the twentieth IPA congress.

The British Psychoanalytic Society also sponsored the Canadian Institute of Psychoanalysis. This professional organization made its initial foray into the professional sphere in 1954 in a university setting, at the Allan Memorial Institute of McGill University (directed by Dr. Ewen Cameron). With the help of Doctor Clifford Scott, agreements were concluded in mid-1954 to initiate a training program identical to that of the British Institute, with three training analysts. After thriving in Britain for a quarter century, Scott, at Cameron's request, returned to Montreal to run the program. The way was now open for training future analysts.

The first students had already begun their training in Montreal, London, Paris, or the United States. Scott helped them complete their training. The other analysts supported this decision, with the exception of Cameron, who had integrated psychoanalysis in his program at the university so it would be under his direct control. When Cameron refused to hire another training analyst, Scott and the other colleagues realized they could avoid his controlling efforts only by forming their own autonomous institute. The training committee of the Canadian Psychoanalytic Society developed and introduced a teaching program in 1958. The first seminar was held on April 4, 1959. On October 1, 1960, members of the society ratified a proposal recommending the creation and incorporation of the Canadian Institute of Psychoanalysis, which was done on March 17, 1961, in Quebec. Jean-Baptiste Boulanger was the first director. The first training program, in 1959, had twelve teachers for thirteen students. Of the thirty-seven candidates trained from 1959 to 1967, eleven were French speakers.

Around 1968 and 1969, for cultural as well as geographic reasons, a federal model was used to create different sections within the Canadian Psychoanalytic Society. A French-speaking section was created in Montreal, the Société Psychanalytique de Montréal, and an English-speaking section in Quebec, the CPS Quebec English Branch. In Ontario the Toronto Psychoanalytic Society was formed. Currently, at the start of the twenty-first century, the Canadian Psychoanalytic

Society has approximately four hundred members, seven sections, and three institutes. In addition to those already mentioned, which have had an associated institute since their formation, three sections—the South Western Ontario Psychoanalytic Society (located in London), the Société Psychanalytique de Québec, and the CPS Western Canadian Branch—do not yet have an institute, while the Ottawa Psychoanalytic Society is still in the process of formation, since it does not have the requisite number of training analysts (five). Service agreements have been concluded with the CPS Quebec English Branch so that candidates of the Ottawa Psychoanalytic Society can continue to be trained locally. For the CPS Western Canadian Branch, the national executive committee recently authorized two training analysts from the Seattle Psychoanalytic Society in the United States to work with the Toronto Psychoanalytic Institute to train candidates in Western Canada locally. Candidates of the Société de Québec must complete their training in Montreal, since the Quebec group has only a single training analyst. Candidates of the Western Canadian Branch in Ontario undergo training at the Toronto Institute.

The CPS Quebec English Branch consists of analysts from Montreal from various ethnic and cultural backgrounds who concentrated on English language and culture when sections were created in 1969. As of 2002, it consisted of a hundred members. The training program of its institute was, until the first few years of the twenty-first century, much more academic than that of the Société de Psychanalyse de Montréal (SPM). Since 2000, the CPS Quebec English Branch has added European authors such as Piera Aulagnier, Wilfred Bion, and Jacques Lacan to the fourth-year program.

Psychoanalysis has also made progress in Toronto. In September 1954, Alan Parkin, who had just completed his training in London, England, arrived in the city. In 1956 he created the Toronto Psychoanalytic Study Circle with a core of eleven psychiatrists with an interest in psychoanalysis. He attempted to establish a psychoanalysis training program at the department of psychiatry of the University of Toronto and obtain recognition for his study group from the Ontario Psychiatric Institute. After two years of activity the circle decided to transform itself into the psychotherapy section of the Ontario Psychiatric Society by opening its doors to all members of that association. The request was ratified on January 23, 1959, and two years later,

on January 20, 1961, the psychotherapy section held its first scientific congress. In his *History of Psychoanalysis in Canada*, Parkin comments on the prodigious growth of this section, which in January 1970 had no fewer than ninety-three members. The establishment of psychoanalysis within the context of psychiatry helped determine the medical orientation psychoanalysis assumed in Ontario. This growth continued until psychoanalytic psychologists of the Ontario Psychological Association, with the support of Division 39 of the American Psychological Association, decided, at the end of the 1980s, to found their own organization, the Toronto Contemporary Society, and their own institute, the Toronto Institute for Contemporary Psychoanalysis. Initially, candidates training at the new institute were not physicians; then psychiatrists began to apply to the organization, although it was not a part of the IPA. They were attracted by the diversity of approaches used in its training program and wanted to escape the incessant conflicts between Freudian and Kohutian factions that divided the Toronto Psychoanalytic Society. The Toronto Psychoanalytic Society would likely have split if there had not emerged a third group, the post-Kleinians, whose members were partisans of object-relations theory and followers of Margaret Mahler and Otto Kernberg. Their emergence prevented the complete polarization of the society. Today the Toronto Psychoanalytic Society has approximately 130 members.

After the formation of the first three sections of the society and the institute, other sections were created when at least five analysts or training analysts belonging to the same geographic or cultural community submitted a request. In 1972 the Ottawa Psychoanalytic Society was formed, followed by the Ottawa Institute in 1978. Then, also in 1978, the CPS Western Canadian Branch was founded, consisting of members scattered throughout the four western provinces. Donald Watterson, in Vancouver, was the first psychoanalyst to settle in British Columbia, yet there was little growth in psychoanalysis in the province until the end of the twentieth century. Julius Guild settled in Edmonton, Alberta, followed by Perry Segal in 1971 and Hassan Azim in 1973, but as of 1998 there was only one analyst in Calgary and two in Edmonton. Similar numbers were found in Winnipeg and Manitoba. Even though it covers an area that is roughly a third of Canada, the CPS Western Canadian Branch currently has only ten members: six in British Columbia, three in Alberta, and one in Manitoba.

The Southwestern Ontario Psychoanalytic Society is the sixth section of the Canadian Psychoanalytic Society. It was founded on June 5, 1982, and currently has fourteen members. Formed in 1988, the Société Psychanalytique de Québec (Quebec Psychoanalytic Society), with ten members, is the most recent of the seven sections of the Canadian Psychoanalytic Society. The senior member is Henri Richard, who began practicing after psychoanalytic training in Paris from 1952 to 1959. A few years later he was joined by Noël Montgrain, who had also studied at the Institut de Psychanalyse de Paris (Paris Institute for Psychoanalysis). There is currently no organization in the maritime provinces of eastern Canada. Aside from the cultural and economic centers of Montreal and Toronto, psychoanalysis throughout Canada has grown very slowly.

For years oral communication was the primary mode of transmission within the Canadian Psychoanalytic Society. The first generations of analysts were more absorbed with fundamental issues and transmission than in the preparation of written texts. Although a number of practitioners—such as W. Clifford M. Scott, Georges Zavitzianos, Jean-Baptiste Boulanger, Jean-Louis Langlois, Paul Lefebvre, André Lussier, Jean Bossé, Pierre Doucet, Guy Da Silva, and Roger Dufresne—wrote important articles, they spent the majority of their time training future generations of analysts.

The ephemeral character of psychoanalytic reviews bears witness to the phenomenon. The first issue of the *Revue canadienne de psychanalyse*, published in 1954 and sponsored by the Canadian Psychoanalytic Society, was the final one until the reappearance, nearly forty years later in the spring of 1993, of the semiannual bilingual *Canadian Journal of Psychoanalysis/Revue canadienne de psychanalyse*, edited by Eva Lester. Similarly, the Société Psychanalytique de Montréal has, since 1988, published an internal periodical three times a year, the *Bulletin de la Société Psychanalytique de Montréal*. Julien Bigras, however, was the first to promote written communication within the psychoanalytic community with the review *Interprétation*, of which he was the founder and editor-in-chief from 1967 to 1971. Josette Garon, Jacques Mauger, Lise Monette, and François Peraldi continued his efforts with the publication of *Fragages*. In the autumn of 1992, Dominique Scarfone published the first issue of *Trans*, a semiannual, semithematic, interdisciplinary journal. The journal played a key role in

encouraging the exchange of psychoanalytic ideas and also played an important role in the Montreal psychoanalytic community by organizing annual colloquia open to the public. Despite this success, the editorial committee decided to discontinue publication in the spring of 1999 with the publication of issue ten of the journal. The year 1992 also saw the introduction of the semiannual *Filigrane*, financed by the publication of *Santé mentale au Québec* and directed at psychotherapists and professional psychoanalysts whose clinical methods were compatible with psychoanalysis.

Patrick J. Mahoney, Jean Imbeault, and Dominique Scarfone are among the first analysts to make significant contributions on an international level to a critical analysis of the psychoanalytic corpus.

In Canada, as elsewhere, the Canadian Psychoanalytic Society and its various sections are not the only entities involved in psychoanalysis. Alongside them have always existed unaffiliated psychoanalysts working alone or in small groups. Among the first to practice psychoanalysis outside an institutional context was Michel Dansereau, a doctor who had trained with René Laforgue in Casablanca, Morocco, and was active during the 1950s. Much later were François Peraldi, who arrived in Montreal in 1974, and Mireille Lafortune, who was active during the late 1960s.

There also exist many organizations devoted to psychoanalysis. In 1986 François Peraldi established the Réseau des Cartels (Network of Cartels), composed of analysts interested in the work of Jacques Lacan. This network did not survive the loss of its founder, and in 2004 only a single cartel is still active. The Association des Psychanalystes du Québec (Quebec Association of Psychoanalysts), founded in 1967 and having only ten members in 2004, is Lacanian in focus. The Association des Psychothérapeutes Psychanalytique du Québec (Quebec Association of Psychoanalytic Psychotherapists), founded in 1985 and consisting of some 150 members in different regions of Quebec, includes clinicians who make use of psychoanalytic methods. The association organizes colloquia and conferences, to which members of the Société Psychanalytique de Montréal are invited. The Groupe d'Études Psychanalytiques Interdisciplinaires (Interdisciplinary Psychoanalytic Study Group) consists of some fifteen professors from the Université de Québec at Montreal who teach psychoanalysis while practicing. The Institut Québécois de Psychothérapie (Quebec



Psychotherapy Institute), which has existed since 1992, provides a two-year training program in analytic and systemic psychotherapy. Father Henri Samson, who trained in France and was a contemporary of Father Mailloux, founded the Institut de Psychothérapie de Québec in the 1960s for those who wanted training in analytic psychotherapy. The Groupe Interdisciplinaire Freudien de Recherches et d'Interventions Cliniques et Culturelles (Interdisciplinary Group for Freudian Research and Clinical and Cultural Interventions), founded by Willy Apollon and cooperating with psychiatrists from the Robert-Giffard Center, has gained a considerable reputation in analytic psychotherapy based on Lacanian principles, especially in its work with psychotic patients. The Cercle Jung de Québec (Quebec Jung Circle), founded in the 1970s by Marcel Gaumont, a Jungian analyst trained at the Jung Institute in Zurich, promotes Jungian psychoanalysis in Canada through public conferences and discussions. André Renaud, a psychoanalyst with the Société Psychanalytique de Québec, established in 1984, and ran until 1996, *Étayage* (Support), a training program for doctors, psychiatrists, psychologists, and social workers who wanted to study analytic psychotherapy. Finally, a group of analytic psychotherapists has also been at work in British Columbia in Western Canada.

JACQUES VIGNEAULT

### Bibliography

- Cloutier, Yvan. (1988). La naissance de la psychanalyse à Montréal. *Philosophiques*, 15(1), 221–225. (Reprinted from *Frayages*, 3 (1987).)
- Paradis, André. (1988). La naissance de la psychanalyse à Montréal. *Revue d'histoire de l'Amérique française*, 41(3), 443–446. (Reprinted from *Frayages, numéro spécial* (1987).)
- Parkin, Allan. (1987). *History of psychoanalysis in Canada*. Toronto: Toronto Psychoanalytical Society.
- Prados, Miguel. (1954). La psychanalyse au Canada. *Revue canadienne de psychanalyse*, 1, 1–33.
- Sourkes, Theodore L., and Pinard, Gilbert (Eds.). (1995). *Building on a proud past: 50 years of psychiatry at McGill*. Montreal: McGill University.
- Vigneault, Jacques. (1993). Transferts et déplacements: fondements de la psychanalyse en Amérique du Nord. *Trans*, 3, 223–237.

**CANNIBALISTIC.** *See* Oral-sadistic stage

### CAPACITY TO BE ALONE

This notion made its first appearance in the mid-1950s in a paper less than ten pages long (Winnicott, Donald, 1958/1965), yet it would be fair to say that today it informs the thinking, and even more the practice, of every psychoanalyst. To be alone in the presence of someone else—what better way could there be of describing the analytic situation and relationship?

Winnicott's aim in his paper is stated without preamble. Rather than the fear of being alone or the wish to be alone, both of which are so often described, what interests him is something that makes it possible to for us to love. He describes a solitude understood not as a defensive withdrawal that cuts us off from a hostile world, nor as neglect, abandonment, or even destruction of the self, but rather as a positive experience and, even more than that, as “a most precious possession” (p. 30).

This is indeed the discovery here, for the capacity to be alone—with the stress on the word “capacity,” for Winnicott speaks elsewhere of a capacity to dream, and there is surely a link between the two—is not a resigned tolerance of the effective absence or disappearance of the other person. This capacity, paradoxically, is quite compatible with the other's presence.

But what is meant by “presence” here? To transform a loss or separation into a departure implying a return—in other words, a “*Fort! Da!*” is itself no easy thing, and to experience the other's absence as their continued presence within oneself amounts to a further step still. To be able to tell oneself “I am alone” without feeling forsaken—such is the prerequisite for what Winnicott considers an essential achievement: to be assured of a sense of continuity as between oneself and the other person, or, better still, to perceive discontinuity in a permanent bond, or even its rupture, as the very precondition of that's bond's survival.

As so often in Donald Winnicott's work, the seeming simplicity of his assertions conceals an analysis of considerable complexity. This is confirmed if one reads “The Capacity To Be Alone” in conjunction

with another, almost contemporary text, “Primary Maternal Preoccupation” (1956/1958), for such a reading makes it clear that the figure of the absent/present “other” should not be too hastily identified—as it frequently is—with the mother as object. Thus a number of authors, among them François Gantheret, prefer to speak of “the maternal” as an extension of what Winnicott—nonetheless reproached by some for idealizing the mother—meant when he wrote of maternal “illness” or “madness.” In venturing to use such terms, Winnicott is referring to an initial state in which the mother experiences the needs of her infant as her own and treats what is external as if it were internal—a state, in short, that is not far removed from psychosis. It is only a break in this continuum, once it is mastered, that can make it possible for “bodily needs” to be transformed into “ego needs,” and using Winnicott’s own words, for a psychology to be born from the imaginary working out of physical experience. This imaginary working out Winnicott calls “ego-relatedness,” as opposed to “id-relationships.” First comes “I am,” which is then as it were amplified by “I am alone” (1958/1965, pp. 33–34).

I am alone and at the same time I am not alone: not that I maintain the presence of the mother within myself; rather, I have managed to disentangle myself from her “madness,” and no longer feel annihilated if she goes away and if I am no longer of concern to her. It may be that each of us must stand in, to some degree, for a maternal environment susceptible to becoming a realm without borders: an “imaginary working out,” a mental life with its own inflows and outflows—truly, a “most precious possession.”

JEAN-BERTRAND PONTALIS

*See also:* Children’s play; Fort-Da; Good-enough mother.

### **Bibliography**

- Gantheret, François. (1984). L’impensable maternel et les fondements maternels du penser. In *Incertitude d’Éros*, Paris: Gallimard.
- Klein, Melanie. (1975). On the sense of loneliness. In *Envy and gratitude and other works 1946–1963* (The writings of Melanie Klein, vol. 3). London: Hogarth/Institute of Psycho-Analysis. (Original work published 1963)
- Pontalis, Jean-Bertrand. (1988). De la mère, le maternel. In *Perdre de vue*, Paris: Gallimard.

Winnicott, Donald W. (1965). The capacity to be alone. In *The maturational processes and the facilitating environment*, London: Hogarth/Institute of Psycho-Analysis. (Reprinted from *International Journal of Psycho-Analysis*, 39 (1958), 416–20.)

———. (1958). Primary maternal preoccupation. In *Collected papers: Through paediatrics to psycho-analysis*. London: Tavistock. (Original work published 1956)

### **CÁRCAMO, CELES ERNESTO (1903–1990)**

An Argentinean physician, psychiatrist, and psychoanalyst, Celes Ernesto Cárcamo was the founder and an honorary member of the Asociación Psicoanalítica Argentina (APA) [Psychoanalytic Association of Argentina]. Born August 11, 1903, in La Plata, he died April 7, 1990, in Buenos Aires.

Cárcamo’s father, who was Spanish, with a PhD in chemistry and pharmacy, came from a long line of doctors. He was well versed in both science and the humanities and devoted much of his time to literature and journalism. His mother, an Argentinean, was the daughter of large landholders originally from the Basque country of France. Cárcamo had a quiet childhood and discovered Freud’s *Interpretation of Dreams* at an early age. He studied medicine as a young man but took courses in philosophy at the state university. He specialized in neuropsychiatry and joined Dr. Mariano R. Castex at the Clínicas Hospital, where the latest methods in medicine were practiced. Here, after studying with James Mapelli, a hypnotist and psychotherapist, he soon realized the limitations of hypnosis. Moved by a profound desire to provide therapeutic services, he studied everything available on psychopathology and psychoanalysis, with a focus on their clinical application.

Since Argentina had few practicing clinicians at this time—most psychoanalysts being self-taught or theorists—he decided to leave for France. At the recommendation of Marie Bonaparte, he studied at the Institut Psychanalytique de Paris (Paris Psychoanalytic Institute). He completed his training analysis with Paul Schiff and was supervised by Rudolph Loewenstein and Charles Odier. In February 1939 he was appointed a member of the Société Psychanalytique de Paris. He associated with scientists and writers such as Ernesto Sábató. In Paris his friend Juan Rof Carballo introduced him to Angel Garma, who wanted to settle in Argentina, and to whom he offered support and advice.

Both men arrived in Buenos Aires in 1939 with the intention of settling there. They began to provide training analyses to help establish an affiliate of the International Psychoanalytic Association (IPA), a project that came to fruition in December 1942. Upon his return to Argentina, Cárcamo had assumed the direction of the department of psychiatry and psychotherapy at the Medical and Surgical Institute of the Durand Hospital Medical School. Here he analyzed some of the pioneers of Brazilian psychoanalysis: Danilo Perestrello and his wife Marialzira, and Alcyon Baer Bahia of Rio de Janeiro, Zaira Bittencourt de Martins from Porto Alegre, and other Latin American analysts. During his tenure as director, the review *Revista de psicoanálisis* was inaugurated, its first issue appearing in 1943.

Cárcamo was the first to teach psychoanalytic technique at the Training Institute. In 1958 he taught the first course in medical psychology at the School of Medicine of the University of Buenos Aires. His writings were collected and published in 1992. Cárcamo was interested in the plumed serpent of the Maya and Aztec religions, the image of the world in aboriginal America, male impotence, female sterility, and the psychoanalytic process. With his wife he translated Anna Freud's *The Ego and the Mechanisms of Defense* and Eugene Minkowski's *Traité de psychopathologie*.

His personal prestige was of considerable benefit to the APA, especially during difficult moments in Argentina's political life. The impact of Cárcamo's personality, his integrity and lack of prejudice, together with his considerable erudition and wit, had a lasting influence on several generations of clinicians whom he analyzed or monitored.

ROBERTO DORIA-MEDINA JR.

See also: Argentina.

### **Bibliography**

- Cárcamo, Celes Ernesto. (1948). Quetzalcoatl: le dieu serpent à plumes de la religion maya-aztèque. *Revue française de psychanalyse*, 12 (1), 101–124.
- . (1984). "Entrevista a los fundadores, III: Celes E. Cárcamo," *Revista de psicoanálisis de la Asociación psicoanalítica argentina*, 41 (6), 987–1000.
- . (1992). *Escritos*. Buenos Aires: Kargieman.
- Doria-Medina, Roberto. (1993). Letter from Buenos Aires: Celes Cárcamo's writings. *Psychoanalytical Books*, 4, 585–594.

Mom, Jorge M., et al. (1982). *Asociación psicoanalítica argentina 1942–1982*. Buenos Aires: A.P.A.

### **CARUSO, IGOR A. (1914–1981)**

An Austrian psychologist and psychoanalyst, Igor Caruso was born February 4, 1914, in Tiraspol and died June 28, 1981, in Salzburg. Born into a family of Italian aristocrats who had settled in Russia, the young Caruso left home to study psychology in Louvain. He wrote his thesis on the development of ethics in children. The growing importance of Piaget and his followers turned his attention to philosophy and orthodox Russian philosophy, German philosophy, and new French thought. In 1942 Caruso settled in Austria and worked for a while as an assistant for children at the large Steinhof psychiatric hospital in Vienna. Shocked by the Nazis' experiments in euthanasia, he left the hospital and found work as a psychologist in a small neuropsychiatric clinic under the direction of Alfred Auersberg. Although he was encouraged to join the "Viennese working group" of the Deutsches Reichsinstitut für Psychologische Forschung und Psychotherapie (German State Institute for Psychological Research and Psychotherapy), there is no proof of his participation. Nor is it certain that he underwent his first analysis with August Aichhorn. However, it is likely that he did his training analysis with Viktor Emil Freiherr von Gebattel, a German psychoanalyst whose philosophical-anthropological-Christian ideology must have fascinated this Italian nobleman more than Aichhorn's charisma, social commitment, or his work with abandoned adolescents.

After the fall of Nazism and the end of the Second World War, Caruso distanced himself from the group formed by the Wiener Psychoanalytische Vereinigung (WPV) [Vienna Psychoanalytic Association], which he found to be too dogmatic. In 1947 he created the Wiener Arbeitskreis für Tiefenpsychologie (Viennese Depth Psychology Study Circle) as a relatively open and autonomous scientific community that rejected any form of strict orthodoxy, even though academic thought was becoming more consistent with orthodox standards.

After spending time studying with Carl Gustav Jung, in 1952 Igor Caruso defined his psychoanalytic program in his *Existential psychology: from Analysis to Synthesis*. Here the term "psychoanalysis" is primarily considered in terms of technique, while Freudian

theory is expanded in the direction of “personal psychoanalysis.” This fixation on the concept of the “totality of the person” led to a consideration of a dialectic relation between freedom and constraint, and between psychophysical conditioning and the transcendent mind as an expression of a hierarchy of values within which the formation of the highest and most sublimated aspects of the mind could not be reduced to primitive drives or understood from a naturalist point of view. The translation of Caruso’s book into six languages not only gave Caruso and his followers international recognition, especially in South America, it also led to the formation of other study circles in the largest cities in Austria. A symposium in Brussels in 1954 on personal psychology provided the opportunity for a meeting between Igor Caruso and Jacques Lacan, which was the start of their intellectual friendship and mutual admiration.

While Caruso’s early theoretical ideas were impregnated with Catholic theological concepts, these gradually disappeared from his writings, giving way to a lively discussion of Freud’s work. In 1957, in *Bios, Psyche, Person*, a book known to the Vienna study circle, he introduced a theory of symbols within the framework of the Freudian theory of drives and in relation to psychic acts and the interpretation of dreams.

During the early sixties, Caruso adopted a kind of Marxist Freudianism, which is apparent in his *Soziale Aspekte der Psychoanalyse* (Social Aspects of Psychoanalysis), 1962. The emphasis, here and in his subsequent essays on the social dimensions of psychoanalysis, implies an analysis of concrete, material structures of power in the analysis of the ego and superego, and of the analyst as the bearer of ideologies and rationalizations of which he needs to be made aware. In 1962 Caruso also published a series of articles that he wrote in French between 1952 and 1961 with the title *Psychanalyse pour la Personne*. It contains his program for the reform of psychoanalysis, which must be, according to Caruso: realistic; in search of truth; concrete; world-based; existential; historic; of its time and therefore liberating; and personalistic, the gradual growth of consciousness leading to gradual personalization (“Une analyse de l’opacité,” 1960).

A confrontation with the phenomenon of separation and refusal of the death impulse led to his *Die Trennung der Liebenden* [Love and Separation], published in 1967. Of his written work (approximately two hundred publications excluding his books) this

essay has become the most widespread and the most popular.

In 1972, Caruso was appointed to the chair of psychology at the University of Salzburg, a remarkable event that reflected the recognition of Caruso and of psychoanalysis in Austria. Following the boom in psychology of the late seventies (the *Psychoboom*), which affected members of the Salzburg study circle and spurred an interest in *Bioenergetik*, transactional analysis, Gestalt therapy, and so on, Caruso felt obligated to show his disapproval by leaving the association, which was now psychoanalytical in name only.

“I am an orthodox disciple neither of Freud nor Jung nor Adler. I am not eclectic, or the head of a new school of psychoanalysts,” wrote Caruso in *Existential Psychology: From Analysis to Synthesis*. His existential psychology was a critical attempt that, in spite of its Freudian references, became increasingly less Freudian.

After his retirement from the University of Salzburg in 1979, Caruso spent the remainder of his life examining theoretical questions, primarily issues of epistemology and methodology characteristic of a psychoanalysis that was closely related to other fields, especially the social sciences.

AUGUST RUHS

See also: Austria; Frankl, Viktor Emil; International Federation of Psychoanalytic Societies.

### Bibliography

Caruso, Igor A. (1962). *Psychanalyse pour la personne*. Paris: Le Seuil.

———. (1964). *Existential psychology: from analysis to synthesis* (Eva Krapf, Trans.). New York: Herder and Herder. (Original work published 1952).

Huber, Wolfgang (1977). *Psychoanalyse in Österreich seit 1933*. Vienna-Salzburg: Geyer.

Parth, Walter (1998). *Vergangenheit, die fortwirkt. Texte. Psychoanalyse. Ästhetik. Kulturkritik*, II, pp. 61–75.

---

## CASE HISTORIES

Case histories are a classic form of documentation in psychopathology literature. They range from clinical sketches to highly detailed and extended accounts, as

in the Madeleine case, which occupies both volumes of Pierre Janet's *De l'angoisse à l'extase* (1926–1928).

Psychoanalysis caused the form to drift toward what might more properly be called a “report on analysis.” With a view to publication, analysts elaborate written accounts based on everything they have heard from a patient, in order to reconstitute the sense and significance of the patient's psychic and symptomatic functioning, as well as the progressive unfolding of the cure itself in the transference/counter-transference exchange.

Sigmund Freud evokes his patients in his early writings (*Studies on Hysteria*, 1895d), but it is in dealing with the analysis of the Rat Man that he expresses the difficulty of giving an account of an analysis, in a letter to Jung dated June 30, 1909: “How bungled our reproductions are, how wretchedly we dissect the great art works of psychic nature! Unfortunately this paper in turn is becoming too bulky. It just pours out of me, and even so it's inadequate, incomplete and therefore untrue. A wretched business.” (1974, p. 238).

Reports are difficult to write because where previously the analyst disentangled the elements in the flow of associations, in order to allow the interpretable meaning to organize itself, in the report, the analyst instead must dismantle and take apart in order to reproduce. Between communication *in* the analysis and the communication *of* the analysis, the transformation is as radical as that which exists between the logic of primary and secondary processes.

The heuristic necessity of the report on the analysis is nevertheless obvious because it is this reflective phase that enables us to focus on any given point of theory, thus breaking not with clinical practice but with the rule of not initially selecting anything in order to afford equally-distributed attention to the associational material. As a transmission of knowledge without a prescriptive target, and relating equally to theory and to clinical practice, the analysis report belongs in the theoretical domain (Laplanche, 1980).

The desire to give an account of the analysis derives from the analyst's counter-transference. The disturbance then becomes the object of thought and the motive for communication and may even remobilize the analyst's questions about his own non-analyzed past. But the report also has an institutional, more or less codified role and forms a part of exchanges that contribute to progress and recognition.

Freud stressed the ethical and moral problems posed by the analysis report: “It is certain that the patients would never have spoken if it had occurred to them that their admissions might possibly be put to scientific uses: and it is equally certain that to ask them themselves for leave to publish their case would be quite unavailing” (1905e [1901]). But he nevertheless defends the necessity for it in a letter to Oskar Pfister (June 5, 1910): “Thus discretion is incompatible with a satisfactory description of an analysis; to describe the latter one would have to be unscrupulous, give away, betray, behave like an artist who buys paints with his wife's house-keeping money or uses the furniture as firewood to warm the studio for his model. Without a trace of that kind of unscrupulousness the job cannot be done” (1963, p. 38).

The models for dreaming and jokes shed light on the respective methodologies used for the situations of dialogue and transcription (Mijolla-Mellor, 1985). While commenting on the difficulties relative to reports on analysis, Freud highlights the necessity for them and also their power of seduction, commenting that his case histories read “like novels” (as in the case of Katharina, 1895), a fair turning of the tables on someone who never hesitated to see novels as the equivalent of case histories.

SOPHIE DE MIJOLLA-MELLOR

*See also:* “A. Z.”; “From the History of an Infantile Neurosis” (Wolf Man); Aimée, case of; “Analysis of a Phobia in a Five-year-old Boy” (Little Hans); Anna O., case of; Cécilie M., case of; Eckstein, Emma; Elisabeth von R., case of; Emmy von N., case of; “Fragment of an Analysis of a Case of Hysteria” (Dora/Ida Bauer); Hirschfeld, Elfriede; Katharina, case of; Little Arpád, the boy pecked by a cock; Lucy R., case of; Mathilde, case of; “Notes upon a Case of Obsessional Neurosis” (Rat Man); Richard, case of; *Studies on Hysteria*.

### **Bibliography**

- Freud, Sigmund. (1905e [1901]). Fragment of an analysis of a case of hysteria. *SE*, 7: 1–122.
- . (1955a [1907–08]). Notes upon a case of obsessional neurosis (Rat Man). *SE*, 10: 151–318.
- Freud, Sigmund, and Breuer, Joseph. (1895d). *Studies on hysteria*. *SE*, 2.
- Freud, Sigmund, and Pfister, Oskar. (1963a). In Heinrich Meng and Ernst L. Freud, (Eds.), *Psychoanalysis and*

*faith: The letters of Sigmund Freud and Oskar Pfister* (Eric Mosbacher, Trans.). New York: Basic Books.

Freud, Sigmund, and Jung, Carl Gustav. (1974a [1906–13]). *The Freud/Jung letters: The correspondence between Sigmund Freud and C. G. Jung* (William McGuire, Ed.; Ralph Manheim and R. F. C. Hull, Trans.). Princeton, NJ: Princeton University Press.

## CASTRATION COMPLEX

In psychoanalysis, the word “castration” is associated with several others that define it and that it in turn defines. These include “anxiety,” “threat,” “symbolic,” “fear,” “terror,” “disavowal,” and above all “complex.” Beyond the everyday connotations of the term, the specifically psychoanalytic definition of castration is rooted in the act feared by male children, namely the removal of the penis. The essential connection between “castration” and “complex” derives from the fact that psychoanalysis views the castration complex, in tandem with the Oedipus complex, as the organizing principle of psychosexuality and, more broadly speaking, of mental life in general.

The metapsychological position of the castration complex was described relatively late in Freud’s work, but the word “castration” appeared earlier, linked to various psychoanalytical notions the consideration of which makes it possible to trace his theoretical course chronologically.

Castration fantasies, the symbolic aspects of castration, and mythological references to castration all figured in *The Interpretation of Dreams* (1900a) and in *The Psychopathology of Everyday Life* (1901b). In the *Three Essays on the Theory of Sexuality* (1905d), where Freud dealt with sexual aberrations, infantile sexuality, and the metamorphoses of puberty, fear and anxiety concerning castration were evoked several times, and the subject became even more prominent in the later revisions of the book. In 1915, and again in 1920, the set of problems surrounding castration was clearly set in its Oedipal context, and castration was treated as a major theoretical and clinical notion.

In “On the Sexual Theories of Children” (1908c), in connection with the evasive answers that parents give to children’s questions as to “where babies come from” and about sexuality in general, Freud noted the coexistence in children (bespeaking a first split in

mental functioning) of an official version, that of the parents, and a set of firmly believed “theories.” The first such theory was the belief that every human being had a penis. It was the collapse of this belief that would give rise to the castration scenario. It is notable that Freud from the outset took the psychosexual profile of the boy as his model; as a result he was led later to explain female psychosexuality by reference to that model. Meanwhile, already in this paper of 1908, he was pointing out how the clitoris was conceived of as “a small penis which does not grow any bigger” and the female genitalia were viewed as “a mutilated organ” (p. 217).

The case history of “Little Hans” (1909b) illustrated and rounded out Freud’s discussion of the “sexual theories of children.” In Freud’s eyes, the castration complex was still a sort of psychopathological nucleus, frequently encountered, which had also left “marked traces behind in myths” (p. 8). This nucleus was amplified with a second surge of the castration threat, the moment of *seeing*, as when Little Hans (aged three and a half) saw that his newborn baby sister had no penis. This observation occasioned an act of disavowal: Little Hans decided that as his sister grew up, her penis would get bigger (p. 11).

Only later, however, in a deferred manner with respect to the two phases of the threat of castration, would castration anxiety make its appearance. Note that Freud long used the words “anxiety” and “terror” almost interchangeably with reference to the fear of castration; he eventually drew a clear distinction in *Inhibitions, Symptoms and Anxiety* (1926d [1925]), contrasting the “anxiety as signal” that triggered repression with the various terrors characteristic of psychosis. Although Freud’s account of 1909 did not yet use the term “phallic,” when he introduced the concept of the infantile genital organization in 1923, he claimed universality for it precisely under that heading.

In *Totem and Taboo* (1912–13a), Freud presented the myth that he believed was the basis of human socialization. The threat of castration and the murder of the father were themes present in Freud’s writings in this vein throughout his work, concluding with *Moses and Monotheism* (1939a). “The Taboo of Virginity” (1918a) had a similar perspective, though it was concerned with more properly psychological issues. This paper was one of a trio of short works called “Contributions to the Psychology of Love.” In the first,

“A Special Type of Choice of Object Made by Men,” the theme of castration was latent throughout, the object-choice under consideration being made from the “constellation connected with the mother” (the mother and the whore “basically...do the same thing”) (1910h, pp. 169, 171). In the second paper, “On the Universal Tendency to Debasement in the Sphere of Love” (1912d), Freud described incestuous wishes as giving rise to an equivalent of castration, either in the direct form of male impotence or, indirectly, by means of projection, in the form of the debasement of the love-object. The third text, “The Taboo of Virginity,” dealt explicitly with the castration anxiety precipitated in men by contact with women, universally recognized as a danger to male sexuality, that is to say, as always potentially castrating.

In the delusions of Dr. Schreber, castration was an obligatory emasculation, but an acceptable one in that it would afford him access to female “states of bliss,” so much more voluptuous than male ones (1911c, p. 29). With “On Narcissism” (1914c), Freud appeared to reject the castration complex; in point of fact, however, his allusion to castration was part of a refutation of Adler’s conception of “masculine protest” (pp. 92–93), while his clear account of the narcissistic hypercathexis of the penis tended on the contrary to reinforce the notions of the castration complex in boys and of penis envy in girls.

The metapsychological papers of 1915 contain no reference to the theme of castration. At the same period, however, Freud was at work on his case history of the “Wolf Man” (1918b [1914]), where castration played a prominent role in the “reconstruction” of his patient’s infantile neurosis. The Wolf Man sought through identification to assume the passive position of his mother during sexual intercourse; he chose the fantasy of anal penetration by his father, implicit in which was a castration fantasy. In this case history Freud opted for several theoretical hypotheses related to castration. These included the definition of femininity; castration as at once feared as a narcissistic injury and desired as a precondition to penetration by the father; repression; erogenous displacement onto the bowel; splitting of processes of thought and ideation; and radical disavowal (*Verwerfung*, translated by Jacques Lacan as *forclusion* (“foreclosure”). All the same, castration as a complex was still not regarded by Freud at this time as an organizing principle of the psyche; he felt simply that as threat, anxiety, or fantasy

it was sufficiently freighted with meaning to bring about reorganizations of the psyche.

In his paper “On Transformations of Instinct as Exemplified in Anal Erotism” (1916–17e), Freud returned to his earlier theoretical options and brought them together, notably with respect to female sexuality and anality. He presented female sexuality as centered on penis envy and on the wish for a child, the two being equivalent. A like set of equivalences obtained in the psyche, “as an unconscious identity,” between feces, penis, gift, and baby—all of them part-objects, all of them small, “detachable” parts of the body (p. 133). In this way Freud came back to the idea of a “pregenital” phase (already mentioned in 1905) predicated on genital castration conceived as anal castration, just as an oral castration could be said to describe separation from the breast. The word “castration” thus came in all cases to indicate the sexual implications—even if they were deferred—of such separations.

“The Infantile Genital Organization” (1923e) was presented as an addition to, and a development of the *Three Essays on the Theory of Sexuality*. The paper stressed the fundamental difference between the pregenital organizations of the libido on the one hand and, on the other, the part played by the infantile genital organization in the two-phase institution of sexuality. The infantile genital phase was characterized by the primacy, in both sexes, of the cathexis of the male genital organ. The evolution of Freud’s thinking here thus concerned not only the discovery of the anatomical difference between the sexes but also the fact that it was the presence or absence of a penis that gave full meaning to that difference. “What is present, therefore, is not a primacy of the genitals, but a primacy of the *phallus*” (p.142). The replacement of “penis” by “phallus” here clearly indicated Freud’s new perspective. Further, and quite logically, he added that “the castration complex can only be rightly appreciated if its origin in the phase of phallic primacy is also taken into account” (p. 144). The sadistic-anal pregenital antithesis between active and passive gave way to the antithesis between phallic and castrated. The sexual polarity between male and female would not coincide with masculine and feminine until puberty.

“The Dissolution of the Oedipus Complex” (1924d) rehearsed some now familiar arguments, but it did so from the phallic perspective proposed in “The Infantile Genital Organization.” The phallic genital organization of the child succumbed to the threat of castration. This

threat was conveyed first through what was understood and then through what was seen; when its full effect was felt, the child “turns away from the Oedipus complex” (p. 176). But the object-cathexes thus abandoned were replaced by identifications. The period of latency followed: libidinal tendencies were desexualized and sublimated, and the introjection of paternal authority formed the nucleus of the superego.

An important issue nevertheless remained unresolved, that of female sexuality, including its relationships with the Oedipus complex, with the superego, and with latency. Was it also characterized by a phallic organization and a castration complex? Freud maintained that the girl, realizing that a clitoris was not on a par with a penis, accepted castration as an established fact. For her the threat of castration and the superego were thus of lesser significance. A more general threat was that of the loss of love. Penis envy tended to be replaced by the wish to obtain an oedipal child from the father.

According to “Some Psychical Consequences of the Anatomical Distinction between the Sexes” (1925j), whereas castration was experienced by boys essentially as a threat, girls looked upon it as a reality to which they were already subject. Either alternative derived directly from the “primacy of the phallus” in both sexes. When the girl observed a boy and his penis, she recognized that she did not have a penis, and wanted to have one. Worse, she might develop a masculinity complex (the wish to be like a man) or, as a further step, disavow reality by “refusing to accept the fact of being castrated” (p. 253). Naturally, the consequences could sometimes be serious, ranging from feelings of unfair treatment to narcissistic injury, from jealousy to the sort of onanistic fantasy described in “A Child Is Being Beaten” (1919e). The mother, in such cases, though the original love object, was blamed for this effective castration.

With puberty, however, a powerful wave of repression would bear down upon all sexual activity in girls that was of a “masculine” stamp (clitoridal masturbation), clearing the way for the development of a passive and receptive femininity. Likewise, and at the same time, she would take her father as an object of Oedipal love and transform her penis envy into the wish for a child from him. In short, “In girls the Oedipus complex is a secondary formation. The operations of the castration complex precede it and prepare for it” (1925j, p. 256).

For Freud, therefore, the anatomical difference between the sexes was interpreted in the same way by

both girls and boys. It is this Freudian account of female sexuality that has been most widely criticized.

*Inhibitions, Symptoms and Anxiety* (1926d [1925]) introduced Freud’s second theory of anxiety: the earlier notion that the affect associated with a repressed idea was converted into anxiety was replaced with a conception of anxiety as an alarm signal that itself triggered repression. Anxiety and the castration complex were both central to this new conceptualization. Revisiting the cases of “Little Hans” and the “Wolf Man,” Freud clearly expressed the view that “the motive force of repression” was anxiety in face of the threat of castration (pp. 107–8). He added that the fear of being devoured, bitten, and so on, as well as animal phobias, and phobias and imaginary fears in general, should also be attributed to castration anxiety, which for its part was the fear of a danger felt to be thoroughly real (*Realangst*). This theoretical picture explained what the three types of neurosis, hysterical, phobic, and obsessional, had in common: “in all three the motive force of the ego’s opposition is, we believe, the fear of castration” (p. 122). Furthermore, whether with respect to pregenital forms (experiences of separation from breast or feces) or with respect to more developed forms (social or moral anxiety stoked by the superego), it was invariably the danger of castration that was feared, and distinctly not the danger of death, no representation of which existed in the unconscious. Nor was the “birth trauma” evoked by Otto Rank involved here.

The prototype of anxiety was the suckling’s state of distress in the absence of its mother; from the economic standpoint, this biological situation implied an increase in the tension created by need. The pivot of anxiety—deferred, relative to that initial distress—was the castration complex. The heir of the castration complex was anxiety vis-à-vis the superego. In women, fear of losing the object’s love played the same role as castration anxiety in men (p. 143).

Freud’s paper on “Fetishism” (1927e) broached the issue of the disavowal of female castration. “Probably no male human being is spared the fright of castration at the sight of a female genital” (p. 154). For the fetishist, at the place where the penis ought to be, there was indeed a penis, in the variable (and often vivid) form of a personal fetish whose presence and employment implied a splitting of the ego: one part acknowledged the castration of women while the other disavowed it, in a single, perpetual process that protected the fetishist from the terror of castration.



In “Female Sexuality” (1931b) and throughout the *New Introductory Lectures on Psycho-Analysis* (1933a), especially in the lectures entitled “Femininity” and “Anxiety and Instinctual Life,” Freud reasserted the importance of the structuring role of the castration complex. He reiterated his general position as follows: “The danger of psychical helplessness fits the stage of the ego’s early immaturity; the danger of loss of an object (or loss of love) fits the lack of self-sufficiency in the first years of childhood; the danger of being castrated fits the phallic stage; and finally fear of the super-ego, which assumes a special position, fits the period of latency” (p. 88).

The closing pages of “Analysis Terminable and Interminable” (1937c) addressed what Freud continued to look upon as an anti-analytical enigma, even, in a sense, a scandal: men would not understand that passive submission to a master does not amount to castration, while women could not admit that they have no penis and that this is their nature. In short, men’s fear of castration and women’s penis envy corresponded to a refusal of femininity (i.e., of castration) by both sexes—a refusal graven in the “bedrock” of the biological (pp. 250–53).

In the myriad forms in which it manifested itself in mental life, as interpreted theoretically by Freud, castration was omnipresent, and closely bound up with the Oedipus complex; if female sexuality was something of a stumbling-block for it, the concept was firmly anchored to the difference between the sexes and the difference between the generations. Starting out from empirical observations, such as those in the case history of “Little Hans,” Freud’s theoretical path led him beyond clinical experience into fundamental questions of epistemology. Castration turned out to be more than the fantasy of a child under threat; embedded in the Oedipus complex and the oedipal situation, this fantasy emerged not only as an organizing principle in the psychic life of the individual but also as prototypical of the “split” which, as distinct from fusion, made possible individuation and the secondary processes (temporality, succession, language, psychical working-out, thought, and so on). In this perspective, Jacques Lacan laid much stress on symbolic castration, making the phallus responsible for the organization of difference, hence for splitting, and hence for the symbolic order, though at the same time he continued to endow this order with the sexual aura specific to the human condition.

It was precisely this anthropological dimension that would seem to have been misapprehended by most English-language authors. For Melanie Klein, admittedly, the castration fantasy continued to play a predominant role in the development of childhood psychosexuality, but it intervened at a late stage, even though she spoke of an early Oedipus complex. As early as the nineteen-twenties, Sándor Ferenczi and Otto Rank had been critical of the castration complex, while, later on, Freud’s account of the link between castration and femininity had, not unjustifiably, been questioned. Castration had barely any place in the theoretical and clinical contributions of D. W. Winnicott, whose definition of femininity was highly original; nor did it have much significance for Wilfred Bion, and it had even less for Heinz Kohut, for whom the Oedipus and castration complexes refer merely to late, relative, and contingent events in mental life.

Another conceptual difficulty that should not be overlooked is that attending the relations between the castration complex and the death instinct. It is notable that *Beyond the Pleasure Principle* (1920g) pays scant attention to the castration complex, whereas *Inhibitions, Symptoms and Anxiety* (1926d [1925]), largely focused on the castration complex, makes no mention of the death instinct.

In its role as organizer of mental life, the castration complex sometimes fails, either because it has not been sufficiently developed to be effective, or because it is apparently overwhelmed. In such cases the subject finds himself grappling directly with instinctual disintegration and exposed to the ravages of the destructive instincts. In psychotic functioning, castration anxiety, so far from playing a structuring role, itself constitutes a terror operating in the same mode as archaic fears of dismemberment.

The fact is that two different perspectives are present here. While Freud undoubtedly considered that the castration complex played a basic organizing role in mental life as a stage in which the anxieties and distress of an earlier time—even the earliest time—were revived in a deferred manner, he simultaneously looked upon it a stage in the formation of the superego. And it was thanks to the part played by the superego that instinctual renunciations would eventually be effected under the pressure of unconscious feelings of guilt and the need for punishment.

Although such instinctual sacrifices were injurious to the individual, they were essential to the “process of

civilization,” that is, to the development of conscience and thought. This process was subject, like the individual, to that instinctual duality which, we must not forget, was based at once upon an antagonism and an inextricable connection between the life and the death instincts. The great lesson of *Civilization and Its Discontents* was that “This conflict is set going as soon as men are faced with the task of living together” (1930a, p. 132). Living together indeed requires at the very least the symbolic marks of sacrifice (circumcision, for instance), and such marks are planted on the sexual body, thus clearly demonstrating the power of the notion of castration in the various registers of human reality.

JEAN COURNUT

*See also:* “Analysis of a Phobia in a Five-Year-Old Boy” (Little Hans); Anxiety; Aphansis; Biological bedrock; Disavowal; Exhibitionism; Fascination; Father complex; Fetishism; Fright; “From the History of an Infantile Neurosis (Wolf Man)”; Identificatory project; Masculine protest (individual psychology); Oedipus complex; Penis envy; Perversion; Phallic mother; Phallic stage; Phobias in children; Phobic neurosis; Primal fantasies; *Psychanalyse et Pédiatrie* (Psychoanalysis and pediatrics); Psychosexual development; Self-mutilation in children; Sex differentiation; “Some Psychical Consequences of the Anatomical Difference between the Sexes”; “Splitting of the Ego in the Process of Defence”; “Taboo of Virginity, The”; Unconscious fantasy.

### Bibliography

*Angoisse et complexe de castration* (1991). Monographs of the *Revue française de psychanalyse*. Paris: Presses Universitaires de France.

Cournut, Jean. (1997). *Épître aux oedipiens*. Paris: Presses Universitaires de France.

Freud, Sigmund. (1900a). *The interpretation of dreams*. SE, 4 and 5.

———. (1901b). The psychopathology of everyday life. SE, 6.

———. (1905d). Three essays on the theory of sexuality. SE, 7: 123–243.

———. (1908c). On the sexual theories of children. SE, 9: 205–226.

———. (1909b). Analysis of a phobia in a five-year-old boy. SE, 10: 1–149.

———. (1910h). A special type of choice of object made by men (Contributions to the psychology of love I). SE, 11: 163–175.

———. (1911c [1910]). Psycho-analytic notes on an autobiographical account of a case of paranoia (Dementia paranoides). SE, 12: 1–82.

———. (1912d). On the universal tendency to debasement in the sphere of love. (Contributions to the psychology of love II). SE, 11: 177–190.

———. (1912–13a). Totem and taboo. SE, 13: 1–161.

———. (1914c). On narcissism: an introduction. SE, 14: 81–105.

———. (1916–17e). On transformations of instinct as exemplified in anal erotism. SE, 17: 125–133.

———. (1918a). The taboo of virginity (Contributions to the psychology of love III). SE, 11: 191–208.

———. (1918b [1914]). From the history of an infantile neurosis. SE, 17: 1–122.

———. (1919e). A child is being beaten. SE, 17: 175–204.

———. (1920g). Beyond the pleasure principle. SE, 18.

———. (1923e). The infantile genital organization (an interpolation into the theory of sexuality). SE, 19: 141–145.

———. (1924d). The dissolution of the oedipus complex. SE, 19: 171–179.

———. (1925j). Some psychical consequences of the anatomical distinction between the sexes. SE, 19: 241–258.

———. (1926d [1925]). Inhibitions, symptoms and anxiety. SE, 20: 75–172.

———. (1927e). Fetishism. SE, 21: 147–157.

———. (1930a). Civilization and its discontents. SE, 21: 57–145.

———. (1931b). Female sexuality. SE, 21: 221–243.

———. (1933a [1932]). New introductory lectures on psycho-analysis. SE, 22: 83–268.

———. (1937c). Analysis terminable and interminable. SE, 23: 209–253.

———. (1939a). *Moses and monotheism*. SE, 23: 1–137.

Green, André. (1990). *Le complexe de castration*. Paris: Presses Universitaires de France.

Lacan, Jacques. (1991). *Le Séminaire VIII. Le transfert (1960–61)*. Paris: Seuil.

Laplanche, Jean (1980). *Problématiques II, Castration, symbolisations*. Paris: Presses Universitaires de France.

### Further Reading

Jacobson, Edith. (1976). Female superego formation and female castration conflict. *Psychoanalytic Quarterly*, 45, 525–538.

Horney, Karen. (1924). On the genesis of the castration complex in women. *International Journal of Psychoanalysis*, 5, 50–65.

Mayer, Elizabeth Lloyd. (1995). The phallic castration complex and primary femininity: Paired developmental lines toward female gender identity. *Journal of the American Psychoanalytic Association*, 43, 17–38.

Rangell, Leo. (1991). Castration. *Journal of the American Psychoanalytic Association*, 39, 3–24.

## CATASTROPHE THEORY AND PSYCHOANALYSIS

The mathematical concept of catastrophe theory was proposed by René Thom in 1968 and was presented in his *Structural Stability and Morphogenesis* (1972/1989). Thom's "Elementary catastrophes" refer to the seven dynamic configurations that a form, being sufficiently stable to be recognized in ordinary space-time, adopts in order to appear, subsist, and change.

René Thom introduced his work as follows:

This work aims to provide a formal structure that can be used to attack any morphogenetic problem in general. Based on a consideration of the mechanisms at work in embryological development, this formal structure leads to a universal method that can be used to associate any morphological appearance with a local dynamic situation that engenders it, in a way that is independent of the substrate—material or immaterial, living or non-living—that supports it. In this way we introduce the notion of 'catastrophe,' whose applications range from physics...to linguistics...and biology. This book provides the first systematic attempt to consider problems of biological control in geometric and topological terms as well as those associated with the structural stability of shapes (1989).

The research on which catastrophe theory depends, as undertaken by Alexandre Liapounov (1857–1918), in Russia, on structural stability, and by Henri Poincaré (1854–1912), in France, on qualitative dynamics, has continued (differential topology, dynamic systems, and so on). Structural stability treats shapes and phenomena according to an intrinsic variability that their persistence in time imposes on them, and not as if they remained strictly identical to themselves—"the simple stability" that classical science requires. In this way the energy a being expends to persist can be taken into account, and consideration given

to the stylization of structurally stable shapes, according to a dynamic that is qualitative because it indicates "state trajectories," possible histories and events, without measuring quantities. Catastrophe theory resolves the following problems: Given a structurally stable dynamic situation dependent on an unknown (or even infinite) number of parameters, it describes all the possible variations and changes in the situation with the help of a finite and minimal number of parameters. If the situation can be represented in conventional space-time, the theory provides for seven kinds of change, the seven elementary catastrophes, depending on at most four parameters.

Determining psychic forms, constructing a dynamic that creates them, then making the problems associated with the stability and regulation of these forms intelligible—their possible histories—was the work of Freud. Psychoanalysis is psychic morphodynamics. That a theory addressing conditions of possibility and constraints can serve to make Freud's work more intelligible goes without saying. A standard case involves the coexistence of primary narcissism and a primary object relation that one of the catastrophes, the "cusp," can be used to model. Similarly, one of the aspects of the duality of the life and death drives can be described as the necessary co-presence of structural and simple stabilities.

The application of the "exact sciences," even the geometrization of a part of thermodynamics, to any non-mathematico-physical domain is complex. But René Thom began to work out the epistemological implications of catastrophe theory. In his *Semiophysics: a sketch* (1988/1990), he developed a *phusis* of meaning. He shows how these mathematics subvert the Galilean subdivision of the world and respond to Aristotle's—and Freud's—questions by treating form and dynamic together in their subjection to time. He then restores the emergence and instrumental value of these mathematics within the framework of natural philosophy, where, by means of "pregnancy"—drives according to Freud—signification becomes a process immanent in a vital dynamic. These analyses, which overturn epistemologies in force since the Galilean revolution, provide access to "laws of nature that are vaster and of greater scope" (1914d) than Freud had hoped.

MICHÈLE PORTE

See also: Dualism; Strata/stratification.

### Bibliography

- Freud, Sigmund. (1914d). On the history of the psycho-analytic movement. *SE*, 14: 1–66.
- Porte, Michèle. (1994). *La dynamique qualitative en psychanalyse*. Paris: Presses Universitaires de France.
- Porte, Michèle. (Ed.). (1994). *Passion des formes. Dynamique qualitative, sémiophysique et intelligibilité. À René Thom*. Paris: E.N.S. Fontenay-Saint Cloud.
- Thom, René. (1989). *Structural stability and morphogenesis: an outline of a general theory of models*. (D. H. Fowler, Trans.). Reading, MA: Addison-Wesley Pub. (Original work published 1972)
- . (1990). *Semiophysics: a sketch*. (Vendla Meyer, Trans.). Redwood City, CA: Addison-Wesley Pub. Co., Advanced Book Program. (Original work published 1988)

---

## CATASTROPHIC CHANGE

The concept of catastrophic change emerged from Bion's mathematical period in which he expressed interested in physical transformations. When an analysand undergoes a violent psychotic change, for instance, what aspects of him remain invariant through that change, from the pre-catastrophic through the actual catastrophic to the post-catastrophic stage. Invariance in change is a concept Bion borrowed from mathematical set theory. He also relates the invariance in change to differing modes of representing an image, such as in art, where the artist has to represent a three-dimensional world on a two-dimensional surface. Bion asserts, "It should...be possible to detect a pattern that remains unaltered in apparently widely differing contexts. It would be useful to isolate and formulate the invariants of that pattern so that it could be communicated" (Bion 1970).

His basic thesis in this regard is that "the psychoanalyst should be regarded as transformation of realization (the actual psycho-analytic experience) into an interpretation or series of interpretations" (Bion 1965). He invokes the term "catastrophic" to designate a psychic event in an analysand that subverts the order or system of things in the environment and/or in the analysand himself, and this catastrophic change represents either a controlled or uncontrolled regression on the part of the analysand where the emergence of violence is pivotal.

Analysis in the pre-catastrophic stage differs from the post-catastrophic stage insofar as the former is characterized by the analysand's being unemotional, theoretical, and not manifesting any evidence of change. In addition, hypochondriacal symptoms are manifested. In the post-catastrophic stage the presence of violation is obvious, it lacks an ideational template, in contrast to the pre-catastrophic stage where "ideational violence" without affect is more in evidence. The analyst must then look, according to Bion, for the invariants in the post-catastrophic stage that correspond as invariants from the pre-catastrophic stage, e.g., hypochondria in the latter may be invariant with paranoid relations with external objects in the former. Returning to the middle stage, catastrophic change, that stage is characterized by the emergence of violence.

Bion encloses the phenomenon of pre-, post-, and catastrophic changes as transformation as follows: In terms of the analysand, the transformation is, when a realization takes place, from T (patient) a to T (patient) b. In the analyst, if there is no observed change, the event is inscribed as T (analyst) a *and* T (analyst) b. In the event of a change, the inscription is: T (pre-catastrophic change) to T (post-catastrophic change).

JAMES S. GROTSSTEIN

*See also:* Hallucinoses.

### Bibliography

- Bion, Wilfred R. (1965). *Transformations: Change from Learning to Growth*, London, Heinemann.
- . (1970). *Attention and interpretation*, London, Tavistock Publications.

---

## CATHARTIC METHOD

The so-called "cathartic method" was a treatment for psychiatric disorders developed during 1881–1882 by Joseph Breuer with his patient "Anna O." The aim was to enable the hypnotized patient to recollect the traumatic event at the root of a particular symptom and thereby eliminate the associated pathogenic memory through "catharsis." The term was derived from Aristotle's use of it to describe the emotionally purgative effect of Greek tragedies.

Reading the case history of Anna O., one sees that the method developed gradually. At first, Breuer limited himself to making use of the patient's self-induced hypnotic states in which she would strive to express what she preferred to avoid talking about when normally conscious. Later on, Anna O. began inventing stories around a word or words she heard, at the conclusion of which she awakened serene and improved. After the death of her father, such stories evoked diurnal fears and hallucinations. The cathartic effect, linked to the emotional state that accompanied these fears, required the doctor to listen without actively seeking etiological clues. Anna O. aptly described this procedure, speaking seriously, as a "talking cure", while she referred to it jokingly as "chimney-sweeping" (1895d, p. 30). At this juncture Breuer began to more systematically employ a technique by which, while Anna O. was in a trance, he repeated to her a few words that she herself had muttered while in a self-induced "absence."

It was probably in August 1881 that the method acquired its definitive form. This was when Anna O., after refusing to drink water and suffering near-hydrophobia during hot weather, remembered the disgust she felt when she happened upon her English lady-companion's dog while it was drinking from a water glass. As soon as she described the event, she asked for water and "thereupon the disturbance vanished, never to return" (p. 35). Other examples provided Breuer with evidence that "in the case of this patient the hysterical phenomena disappeared as soon as the event which had give rise to them was reproduced in her hypnosis" (p. 35), and that systematic application of what she called "chimney sweeping" would put an end to one after another of such morbid phenomena. To move the treatment along faster, Breuer began use hypnosis, which he had not regularly employed previously.

Freud and Breuer filled out the notion of catharsis with the concept of "abreaction"—a quantity of affect that was linked to memory of a traumatic and pathogenic event that could not be evacuated through normal physical and organic processes as required by the "principle of constancy" and so, thus blocked (*eingeklemmt*), was redirected through somatic channels to become the process at the origin of the pathological symptoms (1893a).

Tired of poor results and of the monotony of hypnotic suggestion, by 1889 Freud appears to have

decided, in treating Emmy von N., to employ "the cathartic method of J. Breuer." But failure to regularly induce hypnotic states inclined him by 1892 to give up hypnosis, which his patient Elisabeth von R. disliked. He asked her to lay down and close her eyes but allowed her to move about or open her eyes as she wished, and he experimented with a "pressure technique": "I placed my hand on the patient's forehead or took her head between my hands and said: 'You will think of it [a symptom or its origin] under the pressure of my hand. At the moment at which I relax my pressure you will see something in front of you or something will come into your head. Catch hold of it. It will be what we are looking for.—Well, what have you seen or what has occurred to you?'" (Freud 1895d, p. 110). This procedure "has scarcely ever left me in the lurch since then," (p. 111) Freud added, claiming that this was the case to such an extent that he told patients that it could not possibly fail but invariably enabled him to "at last [extract] the information" (p. 111).

Breuer's method little by little thus became an "analysis of the psyche" which prefigured "psychoanalysis," a term that first appeared in print in 1896. The technique would be developed progressively over the course of a dozen years. By 1907, when Freud undertook analysis of the "Rat Man," he no longer actively demanded that patients produce material, but asked only that they verbalize what spontaneously came to mind.

Freud's thesis, according to which trauma at the root of displaced energy towards the *soma* is invariably sexual in nature, led to a rupture in his relationship with Breuer, but it also determined the future course of psychoanalysis. His explanation of the difficulties that patients experienced during treatment to defend themselves against pathogenic memories would come to be known as "resistance," while the concept of "transference" would emerge from his understanding of Breuer's sudden termination of Anna O., or the time that a patient, upon waking from hypnosis, threw her arms around his neck.

Catharsis and abreaction, even while still observed during psychoanalytic treatment, no longer constitute therapeutic aims as in 1895. However, they remain prominent in several psychotherapeutic techniques, such as in "Primal Scream" therapy and certain types of psychodrama.

ALAIN DE MIJOLLA

*See also:* Dynamic point of view; Economic point of view; First World War: The effect on the development of psychoanalysis; “Instincts and their Vicissitudes”; “Repression”; Topographical point of view; “Unconscious, The”; Witch of Metapsychology, the.

### **Bibliography**

Anderson, Ola. (1962). *Studies in the prehistory of psychoanalysis*. Stockholm: Svenska Bokförlaget.

Chertok Léon; and Saussure, Raymond de. (1973). *Naissance du psychanalyste*. Paris: Payot.

Freud, Sigmund. (1893a). On the psychical mechanism of hysterical phenomena: Preliminary communication. *SE*, 2.

———. (1895d). Studies on Hysteria. *SE*, 2: 48–106.

Mijolla Alain de. (1982). Aux origines de la pratique psychanalytique. In R. Jaccart (Ed.), *Histoire de la psychanalyse*. Paris: Hachette.

energy, which, neutral in itself, can be added to a qualitatively differentiated erotic or destructive impulse, and augment its total cathexis. . . . It seems a plausible view that this displaceable and neutral energy . . . proceeds from the narcissistic store of libido—that it is desexualized Eros” (p. 44). The adherents of ego psychology have made this supposed neutral energy into the energy powering their “conflict-free ego.”

PAUL DENIS

*See also:* Psychic energy.

### **Bibliography**

Freud, Sigmund. (1900a). *The interpretation of dreams*. *SE*, 4–5.

———. (1923b). The ego and the id. *SE*, 19: 1–66.

## **CATHECTIC ENERGY**

In the most general terms, cathectic energy is the energy attached to various psychic formations. Freud used this expression in two different contexts: one where it clearly designates a libidinal cathexis, and another where by implication the energy in question is of a different nature—neutral or desexualized.

In this last, narrower sense, cathectic energy appears in the letter to Wilhelm Fliess of January 1, 1896, as “free psychic energy,” small quantities of energy bound to the phenomena of attention and consciousness. In *The Interpretation of Dreams* (1900a), cathectic energy is the energy invested in thoughts by the preconscious as opposed to the countervailing “energy of the unconscious”: “[the primary processes] appear whenever ideas are abandoned by the preconscious cathexis, are left to themselves and can become charged with the uninhibited energy from the unconscious which is striving to find an outlet” (p. 605). Freud would continue throughout his career to maintain this distinction between the energy whose displacements regulate the processes of thought and fuel cathexis, on the one hand, and the countercahexes of the instinct on the other.

As for the origin of this energy, Freud wrote in *The Ego and the Id* (1923b), for example, that he “reckoned as though there existed in the mind . . . a displaceable

---

## **CATHEXIS**

A key concept from the economic point of view, “cathexis” refers to the process that attaches psychic energy, essentially libido, to an object, whether this is the representation of a person, body part, or psychic element. Implicit in Freud’s early works, the idea of cathexis stems directly from the hypothesis of psychic energy. The term first appeared in 1895 in *Studies on Hysteria*, as well as in “Project for a Scientific Psychology” (1950c [1895]). It then recurs throughout Freud’s works.

The term is used to designate various psychic impulses in energetic terms. As a result, “cathexis” is also used to refer to organizational psychic impulses, the interplay of symptoms and regressions, and the workings of attention and pain. Freud used it to describe major and modulated quantitative phenomena in symptoms and psychic processes. The term also denotes the binding of psychic energy to interconnected representations in the progressive organization of the psyche. Cathexis relates to the affects, where the issue of the quantum of affect becomes paramount (Freud, 1933a [1932]). A feeling not cathected with energy, or loaded with a certain quantity of affect, does not become fixed in memory. Psychic objects and representations are the result of cathexis. Most psychic mechanisms have to be considered from the economic point of view, that is, in terms of cathexis, decathexis, anticathexis, and hypercathexis. The concept

of cathexis thus underpins Freud's entire theory of the constitution of the psyche.

Everything that takes place in the body or the psyche can be an object of cathexis. Real persons are cathected only through the intermediary of the psychic representations constructed of them. Cathexes are objective when they are directed at individuals with a corresponding existence in the external world and are narcissistic when they have meaning only for the subject. Any stable psychic formation, essentially any psychic formation constituted from a stable cathexis, can in turn become the support for a cathexis added to its constituent cathexis.

Every cathexis has an impact on psychic equilibrium because it reduces the quantity of free energy, but the cathexes most constitutive of the psyche are the drive cathexes. Libidinal cathexis of the object of the drive and of the experience of satisfaction obtained in the subject's interaction with that object constitute the most vital internal objects that can support pleasurable ego functioning.

The concept of fixation has to be understood in terms of libidinal cathexes that have remained organized around historically determined objects (in the widest sense). Freud used many different metaphors to describe this process. He used military metaphors to describe how troops (psychic energy) occupy (cathect—the literal meaning of “Besetzung”) a particular piece of the psychic territory and how some of these troops remain behind to establish a base for a return of forces that have completed the advance. Freud also used metaphors from banking, deploying an analogy between libidinal cathexes and financial investments. With the metaphor of an amoeba, Freud illustrated how narcissistic and objective cathexes are related: the pseudopodia that the amoeba extends toward objects are currents of object cathexis that can be withdrawn back into the subject and turned into narcissistic cathexes. The stronger the narcissistic fixation, the greater the potential for narcissistic regression.

The concept of displacement too is related to that of cathexis. Quantities of cathected libido, or psychic energy, can be displaced onto other supports. These displacements result from the greater or lesser capacity of cathected libido to detach from its early objects and from its “viscosity” (1916–1917a [1915–1917]).

Cathected psychic energy is essentially libido. In the context of his structural theory, Freud theorized that

the id is the source of libido and thus the origin of libidinal cathexes. Freud also posited a form of free energy that can emanate from the ego and hypercathect a particular psychic element. Via this process, the ego essentially comes to direct cathexes. Such free energy is neutral and displaceable energy belonging to hypercathexis, which plays a part in the economy of attention, perception, and the ego's preparation for possible traumas (1940a [1938]). It is Freudian formulations of this kind that formed the basis for ego psychology, which postulates a conflict-free sphere of the ego. The term “hypercathexis” is also used more generally to refer to libidinal intensification of an existing cathexis.

In *Inhibitions, Symptoms, and Anxiety* (1926d [1925]), Freud addressed the issue of psychic pain caused by substantial cathexis directed at a lost object. Freud outlined how a painful bodily lesion imposes a substantial narcissistic cathexis that tends to “empty the ego” (p. 171). He then identified cathexis as the common element in physical and psychic pain: “The intense cathexis of longing which is concentrated on the missed or lost object (a cathexis which steadily mounts up because it cannot be appeased) creates the same economic conditions as are created by the cathexis of pain which is concentrated on the injured part of the body” (p. 171).

PAUL DENIS

*See also:* Anticathexis; Cathectic energy; Decathexis; Defense mechanisms; Economic point of view; Ego boundaries; Free energy/bound energy; Hypercathexis; Libido; Object; Primal repression; Psychic energy; Transference relationship.

### **Bibliography**

- Freud, Sigmund. (1900a). The interpretation of dreams. *SE*, 4: 1–338; 5: 339–625.
- . (1910i). The psycho-analytic view of psychogenic disturbance of vision. *SE*, 11: 209–218.
- . (1915e). The unconscious. *SE*, 14: 159–204.
- . (1916–1917a [1915–1917]). Introductory lectures on psycho-analysis. *SE*, 15–16.
- . (1926d [1925]). Inhibitions, symptoms, and anxiety. *SE*, 20: 75–172.
- . (1933a [1932]). New introductory lectures on psycho-analysis. *SE*, 22: 1–182.
- . (1940a [1938]). An outline of psycho-analysis. *SE*, 23: 139–207.

———. (1950c [1895]). Project for a scientific psychology. *SE*, 1: 281–387.

Freud, Sigmund, and Breuer, Josef. (1895d). Studies on hysteria. *SE*, 2: 48–106.

Rouart, Julien. (1967). Les notions d'investissement et de contre-investissement à travers l'évolution des idées freudiennes. *Revue française de psychanalyse*, 31 (2), 193–213.

### Further Reading

Holt, Robert R. (1962). Critical examination: Freud's concept of bound vs. free cathexis. *Journal of the American Psychoanalytic Association*, 10, 475–525.

Ornston, Darius. (1985). The invention of 'cathexis' and Strachey's strategy. *International Review of Psychoanalysis*, 12, 391–400.

---

## CAUSALITY. See Need for causality

---

## CÉNAC, MICHEL (1891–1965)

Michel Cénac, a French psychiatrist and psychoanalyst and member of the Société Psychanalytique de Paris (Paris Psychoanalytic Society), was born June 28, 1891, in Argelès-Gazost (Hautes-Pyrénées), and died in Paris in 1965. He was awarded the Croix de Guerre and the Legion of Honor during the First World War and later studied medicine and psychiatry. An intern at the Asiles de la Seine in 1921, he was a student of Professor Trénel and Henri Claude and later became the head of his clinic. His dissertation, "Langages créés par les aliénés" (The Languages of the Mentally Ill), which he defended in 1928, was primarily devoted to the meaningless jargon often spoken by mentally ill patients. He soon became interested in psychoanalysis and began a training analysis with Rudolph Loewenstein. He was elected a member of the Société Psychanalytique de Paris on November 26, 1929. With Adrien Borel, in 1933 he presented a report on obsession at the VII Conférence des Psychanalystes de Langue Française (Seventh Conference of French-Speaking Psychoanalysts). Preoccupied by the links between medicine and psychoanalysis, in 1934 he published "Ce que tout médecin doit savoir de la psychanalyse" (What Every Doctor

Should Know about Psychoanalysis). In 1936 he opened a clinic for psychoanalysis with John Leuba.

In 1943, when the French police arrested Françoise and Eugène Minkowski, their daughter Jeanine took refuge with Michel Cénac. He intervened with the Prefecture of Police and was able to obtain their freedom. During the Occupation, the term "psychoanalysis" appeared only once in the title of a review, "Psychiatrie et psychanalyse: L'apport de la psychanalyse à la psychiatrie," which he signed and published in March 1943 in *Annales médico-psychologiques*, even though the content of the article reflected the reticence typical of the French (Mijolla, 1982). In a letter to Ernest Jones written on December 31, 1944, John Leuba writes, "Borel and Cénac are working as best they can . . . the second with complete probity but a technique that leaves much to be desired." He was the first treasurer, [RB1] after the Liberation, in 1946 and vice president of the Société Psychanalytique de Paris between 1949 and 1951.

Together with Jacques Lacan, at the XII Conférence in 1950, he presented a paper entitled "Introduction théorique aux fonctions de la psychanalyse en criminologie" (Theoretical introduction to the use of psychoanalysis in criminology), in which both authors expressed their disagreement with theories that stipulated the existence of a criminal instinct. Very much involved with Sacha Nacht in the origins of the 1953 split, on January 20 he announced his candidacy for president of the Société Psychanalytique de Paris against Jacques Lacan. He lost during the third round of voting. Cénac became the first senior physician of the Centre de Diagnostic et de Traitement Psychanalytique, which was created at the same time as the Institut de Psychanalyse de Paris (Paris Institute for Psychoanalysis) in 1954, and was elected president of the Société Psychanalytique de Paris in 1955.

As part of his work at the psychiatric infirmary of the Paris Prefecture of Police, where he became honorary senior physician, Cénac conducted several studies on the value of witnesses (1951), recidivism and anti-social activities (1956), juvenile delinquency (1961), and subjective post-concussional syndromes.

JEAN-PIERRE BOURGERON

See also: France; Société psychanalytique de Paris et Institut psychanalytique de Paris.



### Bibliography

- Borel, Adrien, and Cénac, Michel. (1932). L'obsession. *Revue française de psychanalyse*, V (4), 586–648.
- Cénac, Michel. (Jan.–Feb.–March 1943). Psychiatrie et psychanalyse. L'apport de la psychanalyse à la psychiatrie," *Annales médico-psychologiques*, 101 (1), 278–288.
- Lacan, Jacques, and Cénac, Michel. (1997). A theoretical introduction to the function of psychoanalysis in criminology, May 29, 1950 (Mark Bracher, Russell Grigg, and Robert Samuels, Trans.). *Journal for the Psychoanalysis of Culture and Society*, 1 (2). (Original work published 1951)
- Mijolla, Alain de. (1982). France, 1893–1965. in Peter Kutter (Ed.), *Psychoanalysis international. A guide to psychoanalysis throughout the world* (Vol. I, Europe, 66–113). Stuttgart-Bad Cannstatt: Frommann-Holzboog, 1992.

## CENSORING THE LOVER IN HER

The notion of “censoring the lover in her” was first introduced by Michel Fain, then reworked by Fain and Denise Braunschweig in order to highlight the way in which the mother may modulate her presence for the infant while looking after their bodily needs.

When, in the course of caring for the baby, the mother daydreams about her love life with the father of the child, this other experienced as independent of the child induces a relative distance in the relation with the child. This leads the child to create an early (primary) state of triangulation which will be the basis for the future oedipal organization.

Censoring the lover in her is therefore the effect of the internal events in the mother, leading the developing child to make room for a third party within the framework of their “real” two-person relationship. For the mother it is also this that enables her to counteract the erotic feelings caused by the contact with the infant's body. Her life as a lover thus takes on the value of a protective shield for the psyche of the child, but also for her own psyche because it “censors” a part of the erotic feelings aroused by maternal care.

MICHEL ODY AND LAURENT DANON-BOILEAU

See also: Fatherhood; Maternal object; Object, change of; choice of; Parenthood; Protective shield.

### Bibliography

- Braunschweig, Denise, and Fain, Michel. (1975). *La nuit, le jour. Essai psychanalytique sur le fonctionnement mental*. Paris: Presses Universitaires de France.

- Fain, Michel. (1971). Prélude à la vie fantasmatique. *Revue française de psychanalyse*, 35 (2–3), 291–364.

## CENSORSHIP

The term censorship in everyday language connotes ideas of blame and repression of faults. This is how it appears in Freud in *Studies on Hysteria*: “we are very often astonished,” he writes, “to realize in what a mutilated state all the ideas and scenes emerged which we extracted from the patient by procedure of pressing. Precisely the essential elements of the picture were missing [...] I will give one or two examples of the way in which a censoring of this kind operates...” (1895b, p. 281–282). He then shows that what is censored is what appears to the patient to be blameworthy, shameful, and inadmissible. In a letter to Wilhelm Fleiss (December 22, 1897, in 1950a) he compares this psychic work to the censorship that the czarist regime imposed on Russian newspapers at the time: “Words, sentences and whole paragraphs are blacked out, with the result that the remainder is unintelligible” (1950a, p. 240).

Although the term appears quite frequently in writings from this first period, its status remains uncertain. Freud seems to be describing the deliberate suppression by patients, in their communication with the doctor, of what they do not wish to reveal to him, as well as the mechanism and effects of unconscious repression (1896b). A second meaning appears when he evokes the censorship which, in dream-work, results in a manifest text being presented as a riddle (*Interpretation of Dreams*, 1900a).

The metapsychological texts of 1915 elaborate on the distinctions outlined in chapter seven of the *Interpretation of Dreams*. Censorship is in fact defined as that which opposes the return of that which is repressed, at the two successive levels in the passage from the unconscious to the preconscious (the “antechamber”) and on to the conscious (the “drawing-room”) (1915e).

Censorship is thus clearly distinguished from repression: whereas repression rejects a representation and/or an affect into the unconscious, censorship is what prevents it from re-emerging. Freud nevertheless confuses this distinction later when he writes, for example: “We know the self-observing agency as the ego-censor, the conscience; it is this that exercises the dream-censorship during the night, from which

the repressions of inadmissible wishful impulses proceed” (1916–17a, p. 429). With the introduction of the structural theory Freud made a new distinction, with the ego becoming the agent of the censorship under the superego—the merciless supervisor (1923b).

Although the notion of censorship continues to be fairly widely used in psychoanalysis to describe resistance to the treatment, it has scarcely received any further elaboration and its global nature may cause it to appear to be somewhat outmoded.

ROGER PERRON

*See also:* Censoring the lover in her; Dream; Dream interpretation; Ego; Fantasy; Fantasy (reverie); Fundamental rule; Hysteria; Jokes; Latent; Nightmare; Preconscious, the; Repression; Reverie; Secondary revision; Superego; Wish/yearning.

### **Bibliography**

- Freud, Sigmund. (1895b). On the grounds for detaching a particular syndrome from neurasthenia under the description “anxiety neurosis.” *SE*, 3: 85–115.
- . (1896b). Further remarks on the neuro-psychoses of defence. *SE*, 3: 157–185.
- . (1900a). The interpretation of dreams. *SE*, 4–5.
- . (1915e). The unconscious. *SE*, 14: 159–204.
- . (1916–1917a). Introductory lectures on psychoanalysis. Parts I & II. *SE*, 15–16.
- . (1923b). The ego and the id. *SE*, 19: 1–66.
- . (1950a). Extracts from the Fliess papers. *SE*, 1: 173–280.

## **CENTRE ALFRED-BINET**

The Centre Alfred-Binet (Alfred Binet Center), the department for child and adolescent psychiatry of the Association for Mental Health in Paris, annually receives about two thousand children for consultations and treatment. It is at the center of a group of institutions (Training Club, Foster Home Placement, Adolescent Day Hospital) and operates in coordination with an evening unit (Fondation Lyon) and a specialized homecare unit (Fondation de Rothschild). The system is sector-based, but the center receives 20 percent of its patients from outside of the sector it serves.

Created in 1956 by Serge Lebovici, who was soon joined by René Diatkine, it was the first sector-based center in France for children and adolescents. Breaking with standard practice at the time, the center sought to create essentially outpatient treatment in collaboration with the different institutions in which the children participated. The center was run by psychoanalysts and psychiatrists who were co-opted into the system and who devoted a large part of their time to analysis in an environment of reliable multidisciplinary teams. This fact clearly distinguished this system both from university institutions focused on hospitalization and from a large number of sector services later organized throughout France.

In its development, the center came to rely essentially on psychoanalytic experience and use the mediation of other disciplines. Its practice was progressively elaborated under the influence of its creators, Serge Lebovici until 1978 and René Diatkine until 1994. It continues to have considerable influence on the work of the many public and private practitioners of child psychotherapy and psychiatry who trained in its seminars. The training, while deriving some of its ideas from trends in British psychoanalysis, attempts to define the limits and principles of the analyst’s work with children by constantly sorting out what comes from the child and what comes from the environment.

The necessity of working with families in a climate of trust without inappropriate therapeutic or educational aims and generally for long periods of time led the psychoanalysts to adopt extensive therapeutic consultation and a broad range of treatments that allow children to remain in their usual surroundings. Practitioners take into account the varied conflicts in the psychic lives of the children and the pressure of their unconscious transfer/counter-transfer fantasies without any special fascination for the origin of these fantasies. This has led to a concept of child development as being dominated by successive and barely foreseeable deferred actions on the part of children in which games occupy a special place with regard to the appearance of new functions.

In 2004 nearly five hundred people trained at the Centre Alfred-Binet. In spite of its budgetary restrictions, its evolving practice has enabled it to bring together a group of consultants that benefit parents and children and to organize brief therapy sessions aimed at enlarging the range of activities

where analysts interact with young children and their families.

GÉRARD LUCAS

*See also:* Diatkine, René; Lebovici, Serge; Sindel Charles.

## **CENTRE DE CONSULTATIONS ET DE TRAITEMENTS PSYCHANALYTIQUES JEAN-FAVREAU**

The Centre Jean-Favreau (CCTP) grew out of the Société Psychanalytique de Paris (SPP) and its training institute. The agreement linking it to the Paris Social Services Department (DASS) recognizes its purely psychoanalytic vocation.

At the instigation of Sacha Nacht and René Diatkine, the *Institut de Psychanalyse* created the center in 1954. It was originally a clinic based on a model that the burgeoning psychoanalytic movement created around the time of World War I (it was similar to the Berlin Institute, for example). It provided free treatment to patients who lacked the resources necessary to pay for treatment. Unpaid analysts conducted these treatments, under the supervision of experienced analysts. This system also made it possible to explore the effects of free treatment on the analytic process and to facilitate access for non-physicians.

In 1958 an agreement was signed with the Seine prefecture borough authorities. It guaranteed an operating budget for the center, thus testifying to the public authority's interest in the renewal and use of psychotherapeutic modalities in the field of psychiatry. The center also was to contribute indirectly to training psychiatrists, who, within the framework of the policy of the sector, would then run extra-hospital clinics with a largely psychotherapeutic orientation.

The center's specific role and aims must be seen within this historical context. During a period of great innovation when many institutions were created, integrating psychoanalytic ideas into their treatment perspectives in various ways, the center based its activity around the classic analytic treatment conducted in the course of three or four weekly sessions of forty-five minutes each. This approach derived from the conviction held to this day that psychoanalytic treatment, if implemented correctly, is the most effective treatment, and the belief that psychoanalytic training is the best

way to develop the ability to conduct psychoanalytically oriented psychotherapy.

The other analytic treatments practiced at the center were developed there in order to adapt, up to a certain point, to the range of the demand; among these are various forms of psychotherapy, individual and group psychodrama, and group psychoanalysis. But these other forms of treatment derive from the model of psychoanalytic treatment, of which they are thoughtful modifications taking into consideration the method, the frame, and the processes of change, and wherein clarification of the transference remains of central importance.

The physicians who—delegated by the president of the PPS—have successively directed the center (Jeanne M. Favreau, Jean Favreau, Jean-Luc Donnet) and their assistants (Robert Barande, Monique Cournut) have thus been able to ensure compatibility between the socio-therapeutic obligations required by the agreement and the ethics of psychoanalytic practice. Some fifty analysts—including some candidates—work in the center in a very part-time fashion. The type of patient and the way the center is run make it particularly interesting from a psychoanalytic and psychiatric point of view, for several reasons.

It is a privileged situation wherein to make evaluations and assessments within the consultative framework and to evaluate the types and predictive values of the initial interviews, as well as determining the indications for the various psychoanalytically derived treatments. Its legal status makes it necessary to critically and carefully evaluate the influence of the institutional factors, particularly free sessions, on the therapeutic processes. Of course the optimal analytic situation is one in which the patient pays for the treatment. But it would be inappropriate to establish this principle as a dogma. The availability of free psychoanalytic treatment is not of interest only to patients who lack the necessary resources but, because of the infinite variety of cases seen, it contributes to an ongoing reassessment of the theory of the analytic framework and the constant difficulties surrounding it. Without this in any way taking from its essentially therapeutic aim, the center provides training through its use of consultations for teaching purposes, as well as through participation in the psychodrama sessions.

JEAN-LUC DONNET

*See also:* Favreau, Jean Alphonse; Société psychanalytique de Paris et Institut de psychanalyse de Paris.

---

## CENTRE PSYCHOPÉDAGOGIQUE CLAUDE-BERNARD

Named after the Parisian lycée where it was first installed, the Centre psychopédagogique Claude-Bernard was founded in 1946 on the initiative of Juliette Favez-Boutonier (quickly succeeded by André Berge) and Georges Mauco.

The project came into being during the German Occupation, when these three analysts held informal meetings with Françoise Dolto and Marc Schlumberger. The idea was to create an institution that would enable children, adolescents, and their families to benefit from the discoveries of psychoanalysis in a framework other than hospital consultation. They envisaged a different approach to character disorders, language problems, and intellectual inhibitions. The revolutionary aspects of this project made it quite compatible with the vast plan of social and educational reforms that came into being at the end of the war.

Like other centers later created in other cities, this structure had a dual vocation: medical on the one hand, educational and administrative on the other, the managers of both sections being analysts. This dual vocation symbolized the “crucible” in which actors from all sorts of different disciplines worked for the benefit of the children and their families, but this diversity shared a common horizon: analytic comprehension. In 1972 the center became “medico-psycho-educational” (CMPP).

The social backdrop has changed completely over the last fifty years. Child psychology and psychoanalysis have seen their domains extended and, most of all, considerably deepened. The CMPP model has been contested, although November 1996 saw Claude-Bernard celebrate its fiftieth anniversary in good health!

The Centre had an unquestionable role in the psychoanalytic movement in France. It played a considerable part in spreading psychoanalytic concepts in the domain of education and teaching. In addition, it promoted innovative practices in the psychoanalytic domain: From the very beginning, individual psychotherapy was complemented with the addition of

child and parent group psychodrama. Innovations were also constantly introduced in other domains, educational psychology, psychomotricity, and orthophonics for example.

The question has been raised whether the multiplicity of approaches would not dilute the psychoanalytic idea at the base. On the contrary, it would seem that the conjunction of “impossible tasks” is what makes such an institution rich and dynamic.

CLAIRE DOZ-SCHIFF

*See also:* Berge, André; Clark-Williams, Margaret; Favez-Boutonier, Juliette; France; Mauco, Georges.

---

## CERTAINTY

An internal moral conviction resulting from reflection, or subjectively imposed in the form of an intuition or illumination, certainty is an intellectual sentiment that transposes sensory evidence into the realm of thought. Sigmund Freud gave little thought to the concept except when considering its opposite, doubt, or as related to the idea of conviction, which connotes an illusory or mistaken content (delusional conviction). However, dreams are an example of a mental product accompanied by certainty since images, rather than judgments, are involved. Conversely, whenever there is doubt, it is the misrepresentation that underscores the ability of the element in question to convey meaning.

It is especially in the area of superstition and knowledge of the paranormal that Freud investigated the notion of certainty. As with paranoid delirium, he sees its origin in a projection of the contents of the unconscious onto the outside world (1901b). This idea was developed in connection with animist thought and later with the category of experience, which included feelings of seeing or experiencing something one has seen or experienced before (*déjà-vu* and *déjà-vécu*) (1914a), and feelings of alienation (*Entfremdung*), or the uncanny (*Unheimlichkeit*). What is in question in all of these are “obsolete primal convictions” associated with a primal inability to differentiate between the ego and the outside world.

Freud’s analysis of religious feelings—what Romain Rolland refers to as *oceanic feelings* (1930a [1929])—provided him with an opportunity to question whether certainty is equivalent to an objective perception. These

feelings, he wrote, are “described as feelings but are apparently complicated processes associated with determinate contents and decisions concerning those contents.” The only things that are certain are death and the relation between the mother (*certissima* [absolutely certain]) and the child, while the father is *semper incertus* (always uncertain). The fantasy of certainty, which the most skeptical researcher is never without, can thus be associated with this experience of primary and irreplaceable assurance: that of being the mother’s child. What is certain is irreplaceable. For Freud, the psychoanalyst is prepared “for the sake of attaining some fragment of objective certainty, to sacrifice everything—the dazzling brilliance of a flawless theory, the exalted consciousness of having achieved a comprehensive view of the universe, the mental calm brought about by the possession of extensive grounds for expedient and ethical action” (1941d [1921], pp. 179). This spiritual abstinence is not based on an obsessive predilection for uncertainty but, on the contrary, a desire of anticipated certainty, of possessing fragmentary crumbs of knowledge once and for all (Mijolla-Mellor, S., 1992).

The concept of certainty in psychoanalysis appears to be related both to the analysis of illusion associated with desire (Freud); or, more radically, with the destruction of critical thought, the seductive appeal of deviation, where the only possibility is one of repetition (Aulagnier, 1984), and to the always partial and painfully won acquisition of partial certainties incorporated in a renewed hypothetical-deductive approach.

SOPHIE DE MIJOLLA-MELLOR

*See also:* Construction-reconstruction; Death and psychoanalysis; Déjà-vu; Doubt; Foreclosure; Ideology; Illusion; Paranoia; Pleasure in thinking; Sudden involuntary idea.

### **Bibliography**

Aulagnier, Piera. (1984). *L'apprenti-historien et le maître-sorcier. Du discours identifiant au discours délirant*. Paris: Presses Universitaires de France.

Freud, Sigmund. (1901b). The psychopathology of everyday life. *SE*, 6.

———. (1912–13a). Totem and taboo. *SE*, 13: 1–161.

———. (1914a). Fausse reconnaissance (déjà raconté) in psycho-analytic treatment. *SE*, 13: 201–207.

———. (1914d). On the history of the psycho-analytic movement. *SE*, 14: 1–66.

———. (1930a [1929]). Civilization and its discontents. *SE*, 21: 59–145.

———. (1941d [1921]). Psycho-analysis and telepathy. *SE*, 18: 177–193.

Lacan, Jacques. (1945). Le temps logique et l’assertion de certitude anticipée. Un nouveau sophisme. In *Écrits* (pp. 197–213).

Mijolla-Mellor, Sophie de. (1992). *Le plaisir de pensée*. Paris, Presses Universitaires de France.

---

## **CERTEAU, MICHEL DE (1925–1986)**

Michel de Certeau, Jesuit historian—he was a specialist on the sixteenth and seventeenth centuries and religion—was born in Chambéry in Savoy on May 17, 1925, and died at the age of sixty on January 13, 1986. He was introduced to psychoanalysis by Louis Beirnaert. He was one of the first members of the École Freudienne de Paris in 1964 and remained a member until it was dissolved by Jacques Lacan in 1980. Between 1963 and 1967 he directed the review *Christus*, together with François Roustang, introducing psychoanalysis to the magazine.

His interest in alterity and the Other led him to study the work of Jean-Joseph Surin, a Jesuit mystic of the seventeenth century who was brought in to exorcize the possessed at Loudun. To understand the mystic priest, Certeau made use of psychoanalysis together with semiotics and ethnology. A historian, like Surin, of impossible speech and the broken subject, Michel de Certeau gave exceptional pertinence to Lacanian concepts. In search of the traces of the absent, attentive to the sites of a Real that was impossible to restore, he anchored historical writing in the relation between the body and language and in the constituent division of the subject between “outside” and “inside.”

After 1968 he taught in the Department of Psychoanalysis at the Université de Paris in Vincennes. He later divided his time between the University of California at San Diego and Paris, and was appointed head of research at the École des Hautes Études en Sciences Sociales in 1984.

A tireless investigator of ideas and places, Certeau, in his historical work, demonstrated the fecundity of what Freud referred to as the work of mourning. For

him historical writing is the equivalent of the “tombeau,” a literary and musical genre practiced in the seventeenth century, which gave voice to the past in order to bury it, that is, to honor and eliminate it.

At a time when the social sciences were deeply influenced by scientism, Michel de Certeau felt that history, like psychoanalysis, was dependent primarily on a hermeneutics of loss. He defined an epistemology of the “in-between,” which hovered between science and fiction, and which studied the memory traces inscribed in a present subject to the “uncanny familiarity” of a past that was always ready to rise up to haunt our actions.

FRANÇOIS DOSSE

*See also:* History and psychoanalysis; Religion and psychoanalysis.

### **Bibliography**

Certeau, Michel de (1970). *The Possession at Loudun* (Michael B. Smith, Trans.). Chicago: University of Chicago Press, 2000.

———. (1973). *L'absent de l'histoire*. Repères, Paris: Mame.

———. (1975). *The writing of history* (Tom Conley, Trans.). New York: Columbia University Press, 1988.

———. (1982). *The mystic fable* (Michael B. Smith, Trans.). Chicago: University of Chicago Press, 1992.

———. (1987). *Histoire et psychanalyse entre science et fiction*. Paris: Gallimard, Folio.

## **CHANGE**

The psychic changes observable during psychoanalytic treatment involve two distinct processes. First, the therapeutic process applies to symptoms, personality traits, and behaviors amenable to transformation. Second, the psychoanalytic process applies to how the experience created by the analytic setting and the rules of technique is lived out. The articulation of these two processes defines the question of change in psychoanalysis.

Without ever acquiring a specific conceptual status, the idea of change has been the focus of continual questioning since the beginning of psychoanalysis. As pointed out by Daniel Widlöcher (1970), it is easily traced in Sigmund Freud's work. As early as their

preliminary communication of 1893, which served to introduce their *Studies on Hysteria* (1895d), Freud and Breuer established both the modus operandi of the cathartic treatment of hysteria and the idea that the mechanism of treating the symptom is the reverse of the mechanism of its formation. The recollection of an event and its affective charge spark a process that reverses the pathogenic process brought about by repression. From that point on and indeed throughout the rest of his work, Freud drew on his observation of resistances to change to modify, deepen, and refine his model of change. Three moments mark the beginnings of psychoanalysis: the development of the rules of technique, the shift in focus from trauma theory to the role of fantasy, and the introduction of the concept of change in the form of libidinal development. Here we have an indication of the importance of a model of change to psychoanalysis.

Freud's discovery of the extent and importance of the transference between 1904 and 1910 introduced a new model of change, which is particularly well explained in his *Introductory Lectures on Psychoanalysis* (1916–1917a [1915–1917]). Transference affects the processes of change in several ways. It is an obstacle used by resistance, and it hinders the processes of association and remembering by encouraging repetition through acting out. But it is also a lever for therapeutic transformation, because the patient cathects with the therapist and this reveals features of past attachments and conflicts. Above all, repetition in the transference leads the patient to externalize a conflicted intrapsychic structure and displace it onto the relationship with the analyst. This is the origin of the tripartite therapeutic model of clinical neurosis, transference neurosis, and infantile neurosis.

Beginning in the 1920s, growing doubts about the therapeutic effectiveness of psychoanalysis led Freud to make two basic theoretical revisions. First, he introduced the dualism of the life and death instincts to account for the force of the compulsion for repetition as compared with the inertia of libidinal-object choice. The second revision was based on a more diversified analysis of the processes of resistance to change, which allowed Freud, in “Inhibitions, Symptoms, and Anxiety” (1926d [1925]), to differentiate the resistances of the id, the ego, and the superego—a distinction made possible by the new structural model but also strengthened the clinical effectiveness of treatment. On this basis Freud constructed a third model, which he

formulated in a binary manner: “Where id was, there ego shall be,” he wrote in “New Introductory Lectures on Psycho-Analysis” (1933a [1932], p. 80). In “Analysis Terminable and Interminable” (1937c), Freud offered a more modest version of this formulation, evoking a kind of to-and-fro between ego analysis and id analysis. He was also careful to recall the bases of resistance to change (libidinal viscosity, the repetition compulsion, and also penis envy in women and masculine protest in men).

Throughout his work, in fact, Freud emphasized the study of resistances. In “Analysis Terminable and Interminable” (1937c), he emphasized, “Instead of an enquiry into how a cure by analysis comes about (a matter which I think has been sufficiently elucidated) the question should be asked of what are the obstacles that stand in the way of such a cure” (p. 221).

Have developments in psychoanalytic thinking since Freud followed through on this recommendation? Probably in part, even though the various theories have focused chiefly on their respective models of change. The development of many different schools of thought after Freud owes a great deal to modifications of technique (though only in close association with the work of interpretation) and, in the final analysis, to theoretical approaches that seek to specify the articulations between a pathological model, a developmental model, and a model of change through treatment. Yet all schools of psychoanalysis have based themselves on theoretical and clinical elements already present in Freud’s work. Rather than an expression of allegiance, this is a consequence of the fact that Freud’s theory of change (and the different models successively added to it) covers a very complex reality, of which the various schools have tried to specify a particular portion.

It is worth drawing out a few main themes of these schools, though without reviewing the technical and theoretical frameworks of each (which are rarely presented in connection with the processes of change and resistance to change). The first theme concerns the psychoanalyst’s involvement in the process of change. The idea of a neutral therapist, whose “noninvolvement” ensures the necessary capacity for listening and interpretation, has given way to an ever narrower focus on the analyst’s mental efforts and role in change. This trend, already well underway in Sándor Ferenczi’s innovations in technique, is evident in studies of the role of counter-transference by Paula Meimann and Heinrich Racker, and is currently being

developed around the concepts of interaction, empathy (Ralph Greenson, Heinz Kohut), and “co-thinking” (Widlöcher).

Rather different from the foregoing is the narrative or constructivist tendency. This trend includes the otherwise varied approaches of Jacques Lacan, Roy Schafer, and Serge Viderman, all of whom in their respective ways emphasized how the work of interpretation is constructive.

Another theme is the mechanisms of externalization and internalization. Authors here have returned to the model of transference neurosis to show how pathological structures are displaced in the therapeutic relationship. Often abandoning the classical model of neurosis, these authors (including Melanie Klein and her students, as well as object-relations theorists) describe more archaic processes that become amenable to analysis once they are externalized in the transference.

A third approach stresses the reparative function of the process of change. Change is expected to affect choices of libidinal objects. This trend develops the Freudian idea of the “revision of the process” by placing considerable emphasis on the emotions and the psychoanalyst’s containing function. Such authors as Michael Balint, Donald Winnicott, and Wilfred R. Bion, very different in other respects, belong to this trend.

Other dimensions of change could, of course, be taken into consideration. The most important thing, perhaps, is to identify the reasons for the various divergences on the nature of psychic change and their impact on the activity and future development of the institutions of psychoanalysis. The problem is less one of justifying the existence of several models (which, as noted earlier, has to do with the complexity of the processes involved) than of explaining the reasons for theoretical choices. Clearly, the extension of psychoanalytic treatment to a broader range of cases and the application of psychoanalysis to serious pathologies have had a decisive impact on evolving ideas about change. Will this trend toward disparate models of psychic change continue? If not, what other trend will supplant it? What role will planned research studies, which tend to objectify certain data, play at a time when psychoanalysts are increasingly being held accountable for treatment choices, their effectiveness, and their cost?

DANIEL WIDLÖCHER

See also: Adolescent crisis; Autoplastic; Catastrophic change; Cure; Depersonalization; Ego autonomy; Female sexuality; Mutative interpretation; Narcissistic withdrawal; Object, change of/choice of.

### Bibliography

- Freud, Sigmund. (1916–1917a [1915–1917]). Introductory lectures on psycho-analysis. *SE*, 15–16.
- . (1926d [1925]). Inhibitions, symptoms, and anxiety. *SE*, 20: 75–172.
- . (1933a [1932]). New introductory lectures on psycho-analysis. *SE*, 22: 1–182.
- . (1937c). Analysis terminable and interminable. *SE*, 23: 209–253.
- , & Breuer, Josef. (1893a). On the psychical mechanism of hysterical phenomena: Preliminary communication. *SE*, 2: 1–17.
- Freud, Sigmund, and Breuer, Josef. (1895d). Studies on hysteria. *SE*, 2: 48–106.
- Widlöcher, Daniel. (1970). *Freud et le problème du changement*. Paris: Presses Universitaires de France.

---

## CHANGE PROCESS. See Processes of development

---

## CHARACTER

---

Character is a psychological, philosophical, and a literary concept. A distinction needs to be drawn between this concept and the metapsychological aspects of character and its relation to symptoms and neurosis.

There are two main ways of defining it, which are interconnected. Concepts of character are designated on the one hand by the metapsychological aspects that are intrinsically connected with developments in theory and, on the other hand, by the distinction between normality and pathology and, specifically, the convergence between character and the major concepts of neurosis, psychosis, and borderline conditions.

The concept of character appeared as early as 1900 in *The Interpretation of Dreams* (1900a), in connection with the importance of mnemonic traces. The role of fixations emerged more clearly in 1905 in *Three Essays*

*on the Theory of Sexuality* (1905d), emphasizing the role of sublimation in character formation; Freud wrote: “A sub-species of sublimation is to be found in suppression by reaction-formation” (p. 238). He then described various character types associated with the partial drives in “Character and Anal Erotism” (1908b) and “Some Character-types Met with in Psycho-Analytic Work” (1916d). It was in 1913, in “The Disposition to Obsessional Neurosis: A Contribution to the Problem of Choice of Neurosis” that he most sharply differentiated symptom and character: “the failure of repression and the return of the repressed—which are peculiar to the mechanism of neurosis—are absent in the formation of character. In the latter, repression either does not come into action or smoothly achieves its aim of replacing the repressed by reaction-formations and sublimations” (1913i, p. 323).

In 1923, with the introduction of the structural theory, character is located in the ego and the importance of identifications is emphasized: “an object which was lost has been set up again inside the ego—that is, an object-cathexis has been replaced by an identification. . . . We have come to understand that this kind of substitution has a great share in determining the form taken by the ego and that it makes an essential contribution towards building up what is called its ‘character’” (1923b, p. 28). Character thus comprises the history of object-choices that have since been abandoned. However, the earliness of these identifications should not allow us to forget that the earliest identifications with the parents are those that influence the constitution of the superego rather than the ego (Lecture 32, *New Introductory Lectures on Psycho-Analysis*, 1933a). Here the function of character traits as resistance is frequently emphasized: “we may now add as contributions to the construction of character which are never absent the reaction-formations which the ego acquires—to begin with in making its repressions and later, by a more normal method, when it rejects unwished-for instinctual impulses” (p. 91).

Freud saw a degree of overlap between character and symptom in spite of their differences and maintained that it was the failure of the defensive function of character that led to repression and neurosis; in “Analysis terminable and interminable,” he demonstrated that: “the defensive mechanisms, by bringing about an ever more extensive alienation from the external world and a permanent weakening of the ego,



pave the way for, and encourage, the outbreak of neurosis" (1937c, p. 238).

The "libidinal types" (1931a) have been considered a development of character theory. However, these are in fact an attempt by Freud to attribute a key role to the agencies of the structural theory (id, ego, and superego) in a psychoanalytic nosography.

The study of character has been continued by various authors but it has been overtaken by the subject of character resistance and the associated problems of technique. Karl Abraham emphasized the importance of fixations, although he cautioned against the notion of a fixed nature as something that is disproved by modifications in character ("A Short Study of the Development of the Libido," 1924/1927). He set out to establish a semiology of psychic material and emphasized the earliness of object relations involved in symptom-formations and character-formation. Wilhelm Reich is known mainly for the modifications in technique that he advocated with patients who presented him with "character armor." This means avoiding interpreting drive impulses before having interpreted and overcome this resistance, layer by layer. In their demonstration that a large number of muscular reactions are designed to prevent the breakthrough of emotions, excitations, or anxiety, these descriptions are reminiscent of Pierre Marty's discussions of rachialgia (1963).

In *The Psychoanalytic Theory of Neurosis* (1945), Otto Fenichel also demonstrated the need to resolve the conflicts between the drives and defenses. Raymond de Saussure considered character as a developmental stage in which the subject has become stuck and not as a type that is established for a lifetime.

Jean Bergeret (1976) described character and structure by distinguishing three levels of character: Character, as an emanation from the deep structure in relational life, traces the progress or failure of the structural development; character traits, elements of the fundamental character, are often associated with elements of other forms of character, compensating for deficiencies in fundamental character through adaptive requirements, and can thus appear in a different structure from the one from which they derive. Character pathology, on the other hand, corresponds to the "borderline" economy and its decompensation leads to a deformation of the ego, with the onset of more or less severe forms of splitting.

Otto Kernberg's work on character forms part of his studies of borderline functioning. In "A psychoanalytic classification of character pathology" (1970), he proposed a classification of character pathologies with three levels of severity, corresponding to the level of development of the drives, the superego or the ego, or the more or less pathological nature of the character traits. The three levels of severity that he distinguishes are reminiscent of the levels of mentalization in Pierre Marty's theory of character neurosis.

The issues raised by character traits continue to be of interest to the French psychosomaticians among others. In "Névrose de caractère et mentalisation" (Character neurosis and mentalization) for example, Michel Fain (1997) argued that the disappearance of a character trait indicates a dementalization occurring in an essential depression rather than the resolution of a neurotic process.

ROBERT ASSÉO

*See also:* Anal-sadistic stage; *Character Analysis*; Character formation; Character neurosis; "Confusion of Tongues between Adults and the Child"; Countercastration; Dependence; Ego; Eroticism, anal; Eroticism, urethral; Failure neurosis; Fate neurosis; I; Identification; Indications and contraindications for psychoanalysis for an adult; Orality; Paranoia; Psychic structure; Psychological types (analytical psychology); Reaction-formation; *Sex and Character*; Sublimation; Transference neurosis; Transgression.

### **Bibliography**

- Abraham, Karl. (1927). A short study of the development of the libido. *Selected papers of Karl Abraham*. London: Hogarth. (Original work published 1924)
- Bergeret, Jean. (1976). Personnalités normales et pathologiques: Les structures mentales, le caractère, les symptômes. *Revue française de psychanalyse*, 40 (2), 351–370.
- Fain, Michel. (1997). Névrose de caractère et mentalisation. *Rev. française de psychosomatique*, 11, 7–17.
- Fenichel, Otto. (1945). *The psychoanalytic theory of neurosis*. New York: W. W. Norton.
- . (1900a). The interpretation of dreams. *SE*, 4–5.
- . (1905d). Three essays on the theory of sexuality. *SE*, 7: 123–243.
- . (1908b). Character and anal erotism. *SE*, 9: 167–175.

- . (1913i). The disposition to obsessional neurosis: A contribution to the problem of choice of neurosis. *SE*, 12: 311–326.
- . (1916d). Some character-types met with in psychoanalytic work, *SE*, 14: 309–333.
- . (1923b). The ego and the id. *SE*, 19: 1–66.
- . (1931a). Libidinal types. *SE*, 21: 215–220.
- . (1933a). New introductory lectures on psychoanalysis. *SE*, 22: 1–182.
- . (1937c). Analysis terminable and interminable. *SE*, 23: 209–253.
- Kernberg, Otto. (1970). A psychoanalytic classification of character pathology. *Journal of the American Psychoanalytic Association*, 18, 800–822.
- Marty, Pierre. (1963). *La psychosomatique de l'adulte*. Paris: Presses Universitaires de France.
- Reich, Wilhelm. (1945). *Character analysis: Principles and technique for psychoanalysts in practice and in training* (Theodore P. Wolfe, Trans.). New York: Orgone Institute Press. (Original work published 1933)

## CHARACTER ANALYSIS

In the course of his clinical work in Vienna (1924–1930) and then in Berlin (1930–1933), Wilhelm Reich worked out his own techniques of psychoanalytic practice that emphasized the analysis of resistances and the structure of the character. He made his techniques public in his book, *Character Analysis* (1933/1945), his richest contribution to psychoanalysis. Character represents a stable, more or less rigid, organization of the libidinal economy of the person; it is at the same time submitted to the pressures of the drives and to social constraints, to gratifying or traumatic experiences, and to the repetitions or defenses that they give rise to: “Character is in the first place a mechanism of narcissistic protection.”

The “character traits” that it brings together under the name of “character armor” correspond to the mechanisms used by the person to deal with the repressed. Reich described two great poles of character, defined by their degree of “orgasmic potency” and the prevalence of various states of the libido: The genital character, the Reichian ideal, is distinguished by an orgasmic potency that reaches a true plenitude, a flexible and free circulation of libidinal energy, and also by modes of relation to the self, to others, and to the

world, founded on a rational approach that respects the reality principle. The neurotic character, conversely, suffers from a libidinal imbalance that gives primacy to repression and negation or, in other cases, to impulsivity and an inability to master the pressure of unconscious impulses. In addition to these fundamental character types, Reich described “some well defined forms of character,” such as the hysteric character, dominated by ostentation and sexual mobility; the compulsive character, where rigidity, retention, and obsession for order dominate; and the phallic-narcissistic character, structured so as to resist the “anal and passive-homosexual impulses.” For the masochistic character, Reich refers, through several individual examples, to a cultural form marked by guilt and the desire for punishment—in short, the death drive, as the source of the tendency towards such deadly political practices as fascism.

Reich’s broadening of character analysis included a third part called “On the Psychoanalysis of the Biophysics of Orgone,” in which Reich, linking “physical contact” and “vegetative current,” emphasized the role of violent, elementary sensations such as the feeling of “breakdown” and the “representation of death.” He proposed, on this basis, an original interpretation of the “schizoid disintegration,” by which certain symptoms typical of schizophrenia—the “faraway stare,” dissociation of the personality, and catatonia—are presented in a clarifying and suggestive light. By inscribing his researches within a “language expressive of life,” Wilhelm Reich committed himself to a vitalist vision that shall see subsequent and more ample developments.

ROGER DADOUN

*See also:* Character; Character formation; Character neurosis; Reich, Wilhelm.

### Source Citation

Reich, Wilhelm. (1945). *Character analysis: Principles and technique for psychoanalysts in practice and in training* (Theodore P. Wolfe, Trans.). New York: Orgone Institute Press. (Original work published 1933)

### Bibliography

- Boadella, David. (1973). *Wilhelm Reich, The evolution of his work*. Chicago: Henry Regnery.
- Dadoun, Roger. (1975) *Cent fleurs pour Wilhelm Reich*. Paris: Payot.

## CHARACTER FORMATION

Character is a psychological notion that refers to all the habitual ways of feeling and reacting that distinguish one individual from another. Sigmund Freud had a sustained interest in the question of character formation, since it touches on the major themes that interested him: “anatomo-physiological destiny,” memory traces, and, more generally, the role of acquired traits, as well as the function of sublimation with regard to the “remains” of the pregenital libido.

In *The Interpretation of Dreams* (1900a), Freud defined character in relationship to the unconscious: “What we describe as our ‘character’ is based on the memory-traces of our impressions; and, moreover, the impressions which have had the greatest effect on us—those of our earliest youth—are precisely the ones which scarcely ever become conscious” (pp. 539–540). This definition posits character as a sort of memory, a collection of traces. Five years later, in *Three Essays on the Theory of Sexuality* (1905d), Freud emphasized individual psychic activity: “What we describe as a person’s ‘character’ is built up to a considerable extent from the material of sexual excitations and is composed of instincts that have been fixed since childhood, or constructions achieved by means of sublimation, and of other constructions, employed for effectively holding in check perverse impulses which have been recognized as being unutilizable” (pp. 238–239).

In 1920, in an addendum to the *Three Essays* that reiterates material presented in the article “Character and Anal Erotism” (1908b), Freud summarized, “Obstinacy, thrift and orderliness arise from an exploitation of anal erotism, while ambition is determined by a strong urethral-erotic component” (p. 239, n. 1). Character derives from instincts, but not directly, since reaction formations and sublimations intervene. Thus, as Freud noted in “Thoughts for the Times on War and Death” (1915b), “The pre-existence of strong ‘bad’ impulses in infancy is often the actual condition for an unmistakable inclination towards ‘good’ in the adult” (p. 282).

With the development of the notion of identification, that of character took on additional dimensions. Character formation was understood to be based on the mechanism of identification, that is, unconsciously identifying with character traits derived from objects. According to Freud in *The Ego and the Id* (1923b),

when a lost object is reestablished in the ego, thus allowing an identification to replace object cathexis, this “makes an essential contribution towards building up what is called its ‘character’ ” (p. 28).

The notion of character thus evolved in Freud’s work. The importance Freud attributed to it can be seen in his remarks in “Freud’s Psycho-Analytic Procedure” (1904a), where he wrote, “Deep-rooted malformations of character, traits of an actually degenerate constitution, show themselves during treatment as sources of a resistance that can scarcely be overcome” (p. 254). However, determining character traits is not easy. In “Some Character-types Met with in Psycho-Analytic Work” (1916d), Freud noted that it is not the character traits that patients see in themselves, nor those attributed to patients by persons close to them, that pose the greatest problem for analysts; rather it is the previously unknown and surprising peculiarities often revealed in the course of analysis. Freud analyzed some of the character types revealed through analysis, including those of subjects who claim for themselves the right to perpetrate injustice because they believe they have been subjected to it themselves, subjects “wrecked by success” (pp. 316 ff), and finally, taking a perspective that changed criminology, “criminals from a sense of guilt” (pp. 332 ff).

Karl Abraham (1925/1953–1955) returned to the specific issue of the anal character. A broader, more central notion of character can be found in the work of Wilhelm Reich (1933/1945). The idea of character analysis, and especially that of “character armor,” are linked to his theories of a biological energy that he later named “orgone energy.” Subsequently, these theories became a separate discipline from psychoanalysis, “bioenergy.” Citing the work of Edward Glover and Franz Alexander (who contrasted character neurosis and symptomatic neurosis), Reich reconsidered the known character types (hysterical, obsessional, masochistic, etc.) under the presupposition that the primordial function of any character type is to defend against stimulations from the external world and against repressed internal instincts. The character analysis he developed consists in isolating in the patient the character trait that is the source of greatest resistance and thus rendering it analyzable. His general idea is that the ego forms a character trait by taking over a repressed instinct to use as a defense against another instinct. Thus, character is essentially a mechanism of narcissistic protection—hence the term “character armor.”

After Reich, character became far more important among psychoanalysts whose work focuses on the ego. In the United States many studies have been published on this topic, notably Heinz Hartmann's *Ego psychology and the problem of adaptation* (1939/1958).

SOPHIE DE MIJOLLA-MELLOR

See also: Character.

### **Bibliography**

- Abraham, Karl. (1953–1955). Contribution of the theory of the anal character. In *Selected papers of Karl Abraham, M.D.* (Douglas Bryan and Alix Strachey, Trans.). New York: Basic Books. (Original work published 1925)
- Freud, Sigmund. (1900a). The interpretation of dreams. *SE*, 4: 1–338; 5: 339–625.
- . (1904a). Freud's psycho-analytic procedure. *SE*, 7: 249.
- . (1905d). Three essays on the theory of sexuality. *SE*, 7: 123–243.
- . (1908b). Character and anal erotism. *SE*, 9: 167–175.
- . (1915d). Thoughts for the times on war and death. *SE*, 14: 273–300.
- . (1916d). Some character-types met with in psycho-analytic work. *SE*, 14: 309–333.
- . (1923b). The ego and the id. *SE*, 19: 1–66.
- Hartmann, Heinz. (1958). *Ego psychology and the problem of adaptation*. New York: International Universities Press. (Original work published 1939)
- Reich, Wilhelm. (1945). *Character-analysis: principles and technique for psychoanalysts in practice and in training* (Theodore P. Wolfe, Trans.). New York: Orgone Institute Press. (Original work published 1933)

### **Further Reading**

- Lewin, Betram. (ed.) (1966). *On Character and Libido Development. Six Essays by Karl Abraham*, New York: W. W. Norton & Co. Arlow, Jacob A. (1990). Psychoanalysis and character development. *Psychoanalytic Review*, 77, 1–10

---

## **CHARACTER NEUROSIS**

The term “character neurosis” did not originate with Freud. It grew out of difficulties in treating character pathologies, distinguished by the great resistance that

character opposes to analysis. And its use spread in the wake of Wilhelm Reich's work on character analysis beginning in 1928. Sigmund Freud, in lecture 34 of his *New Introductory Lectures on Psycho-Analysis* (1933a [1932]), underscored the often extremely long duration required by character analysis, but, he assured readers, “it is often successful” (p. 156).

It was undoubtedly a lack of success with such cases that led Reich to his conception of “character armor.” At the time he was working at the Vienna Psychoanalytic Clinic with impulsive psychopaths. The problems raised by their treatment, he said, required a sharp focus on the structure of the impulsive ego.

The difficulties of regression in the transference, the inaccessibility of character fixations to analysis, and the difficulty of investing the analyst except in an idealizing mode (a defense against any erotic or aggressive investment) form the basis for the analysis of character pathologies. In his Vienna seminars between 1922 and 1926, Reich noted that the obstacle to a cure is found in the patient's whole character. He advocated a rigorous analysis of the character defenses, layer by layer, before any deep interpretation.

Hermann Nunberg (1956), denouncing what he saw as the artificial separation of the analysis of resistance and the analysis of deep contents, had serious disagreements with Reich with regard to the techniques to be implemented. In “Le traitement psychanalytique du caractère” (1928/1982), Sándor Ferenczi argued that the analyst has to reveal how character traits are unconsciously used to resist analysis and has to link them to the corresponding forgotten childhood experiences, in particular, experiences of seduction by an adult, for analysis to progress. This is in keeping with what he called analytic pedagogy, which makes use of his active technique. Following Ferenczi, Michael Balint (1932/1952) emphasized the effects of the fear of excitation, and indeed of pleasure itself, often the result of hyperstimulation of the child by an adult.

Later Otto Kernberg, in “A psychoanalytic classification of character pathology” (1970), sought to establish a form of classification based on the increasing severity of pathological manifestations by integrating the various nosographic and metapsychological data (agencies, part instincts). This terminology is reminiscent of Pierre Marty's 1980 classification of neuroses as well, poorly, or irregularly mentalized, or even as

behavioral neuroses. According to Marty, the same metapsychological elements are paramount: deficiencies in mentalization correspond to deficiencies in object internalization and to acting out, which give rise to behavior disorders. René Diatkine (1966) emphasized the suffering of persons close to the patient; in his view, the ego-syntony of character protects the subject from anxiety. Henri Sauguet (1966) established a gradation between neurotic character (close to the symptomatic neuroses) and character neurosis (close to borderline states or even psychosis).

Despite the importance of, and the number of authors who have taken an interest in, character neurosis, in France this notion is obsolescent because the general focus has shifted toward problems of symbol formation and identity construction. The term nevertheless retains some currency among psychosomatically oriented analysts, particularly in France. One area being researched concerns the connections among the structure of the superego, the presence of the ideal ego (in Marty's sense), and the quality of mentalization. In "Névrose de caractère et mentalisation" (Character neurosis and mentalization; 1997) Michael Fain emphasized how character defenses play a protective role: "The disappearance of character traits more often attests to a dementalization taking place in an essential depression than to the resolution of a neurotic process."

ROBERT ASSÉO

See also: Character.

### Bibliography

- Balint, Michael. (1952). Character analysis and new Beginning. In his *Primary love and psychoanalytic technique*. London: Hogarth. (Original work published 1932)
- Diatkine, René. (1966). Intervention au 7e séminaire de perfectionnement. *Revue française de psychanalyse*, 30 (3), pp. 324–344.
- Fain, Michel. (1997). Névrose de caractère et mentalisation. *Revue française de psychosomatique*, 11, 7–17.
- Ferenczi, Sándor. (1982). Le traitement psychanalytique du caractère. In his *Œuvres complètes*. Vol. 4: *Psychanalyse, 1927–1932*. Paris: Payot. (Originally published 1928.)
- Freud, Sigmund. (1933a [1932]). New introductory lectures on psycho-analysis. *SE*, 22: 1–182.
- Kernberg, Otto F. (1970). A psychoanalytic classification of character pathology. *Journal of the American Psychoanalytic Association*, 18 (4), 800–822.
- Marty, Pierre. (1980). *Les mouvements individuels de vie et de mort* (Vol. 2: *L'ordre psychosomatique*). Paris: Payot.
- Nunberg, Hermann. (1956). Character and neurosis. *International Journal of Psycho-Analysis*, 37 (1), 36–45.
- Reich, Wilhelm. (1945). *Character-analysis: principles and technique for psychoanalysts in practice and in training* (Theodore P. Wolfe, Trans.). New York: Orgone Institute Press. (Original work published 1933.)
- Sauguet, Henri. (1966). Caractère et névrose. *Revue française de psychanalyse*, 30 (3), 298–307.

### Further Reading

- Kernberg, Otto F. (1970). A psychoanalytic classification of character pathology. *Journal of the American Psychoanalytic Association*, 18, 800–822.
- Nunberg, Henry. (1956). Character and neurosis. *International Journal of Psychoanalysis*, 37, 36–45.

## CHARCOT, JEAN MARTIN (1825–1893)

Jean Martin Charcot was born in Paris in 1825, the son of a coach builder, and died of a heart attack near Lake Settons (Nièvre) on August 16, 1893. He was a physician with the Hôpitaux de Paris, a professor of clinical medicine for nervous disorders, and a member of the Académie de Médecine.

He was appointed a physician with the Hôpitaux de Paris in 1856, associate professor of medicine in 1860, senior physician at the Salpêtrière in 1862, professor of pathological anatomy in the School of Medicine at the University of Paris in 1872 (succeeding Alfred Vulpian), and in 1882 was appointed to the first chair of neurology, a position created for him at the request of Léon Gambetta, as professor of diseases of the nervous system. He was made a member of the Académie de Médecine in 1873 and the Académie des Sciences in 1883,

Charcot had an impressive career and received numerous academic honors, but the accuracy of his theories on hysteria, which he began working on in 1865 after the "department of epilepsy" was placed under his supervision, had begun to be seriously questioned at the time of his death. The work of his student, the neurologist Joseph Babinski; the rise of Pierre Janet's dynamic psychology; and especially the success of psychoanalysis all contributed to bringing down a

theoretical structure that had nurtured these developments at the beginning of the twentieth century.

Charcot was an attentive observer, which helped establish methods of neurological description and classification still in use (Charcot's disease, Charcot-Bouchard aneurysm, and so on), and possessed an almost magical talent as a speaker. He attracted a diverse group of personalities to his presentations: his public "Leçons Cliniques," held on Wednesdays, and his "Grandes Leçons," held on Fridays. His patients, it was learned after his death, had to some extent been prompted to exhibit to the audience the typical "hysterical crises" that the Master expected of them. He was particularly interested in paralysis, anesthesia, and other symptoms considered to be "hysterical," and attempted to demonstrate their "functional"—rather than anatomical—origin, a belief that contradicted a number of other practitioners, who were proponents of the surgical removal of their patients' ovaries.

He succeeded in isolating a clinical entity he referred to as the "grande hystérie" or "hystero-epilepsy." He described a crisis, or "attack," as occurring in four successive phases: the epileptiform phase, clonic spasms, emotional "acting out," and terminal delirium. In addition to these attacks patients exhibited "stigmata" (narrowing of the visual field, anesthesia)—conditions that could only exist if there were some form of "diathesis," that is, a predisposition to hereditary degeneration.

To demonstrate his ideas, Charcot publicly performed hypnosis to provoke or eliminate such symptoms, which proved they were not connected to organic lesions, unlike true neurological disorders. This was a step toward a "psychological" conception of the origin of hysterical symptoms, but Charcot wrote in 1887, "What I call psychology is the rational physiology of the cerebral cortex." He gave encouragement to the new field with the creation, in 1890, of the Laboratory of Psychology at the hospital, with Pierre Janet as its head. He supported Janet in his work on his dissertation, "L'État mental des hystériques" (The Mental State of Hysterics; 1893), and ensured publication of the work of Sigmund Freud in French medical reviews.

Freud's work with Charcot at the Salpêtrière contributed greatly to Freud's later work and the birth of psychoanalysis. Arriving in Paris on October 13, 1885, with the help of a grant from the School of Medicine

of the University of Vienna to study anatomic pathology, he was introduced to hysteria and its "psychological" etiology, which had a decisive influence on his decision to treat patients privately, which he did when he returned to Vienna in the spring of 1886.

A month after his arrival in Paris, on November 24, 1885, he wrote to his fiancée, "Charcot, who is one of the greatest of physicians and a man whose common sense borders on genius, is simply wrecking all my aims and opinions. I sometimes come out of his lectures as from out of Nôtre Dame, with an entirely new idea about perfection. . . . Whether the seed will ever bear fruit, I don't know; but what I do know is that no other human being has ever affected me in the same way." Before he left Paris at the end of February 1886, Freud obtained Charcot's approval to translate his *Leçons cliniques* into German. He took with him a number of expressions that proved useful to him later on: "theory is good, but that doesn't prevent its existence," "in those cases, it's always genital," "the wonderful indifference of hysterics," "the refusal of the sexual is enormous, like a house."

Freud and Charcot maintained their relationship through correspondence, even though the personal comments Freud added to the *Poliklinische Vorträge* (1892–1894a), his translations of the *Leçons du mardi*, left a somewhat bittersweet residue (Mijolla). Although Charcot was not interested in the cathartic method Freud had spoken to him about, Freud left the hospital with a draft for an article on hysterical paralysis that took him seven years to complete, but when published in French in the *Archives de neurologie* (1893c), represented the first "psychoanalytic" approach to the phenomenon. Freud named his first son Jean Martin, and throughout his life kept a reproduction of André Brouillet's painting *Une leçon clinique à la Salpêtrière*.

In his homage to Charcot at the time of his death, Freud confirmed his rejection of Charcot's theories but at the same time expressed his gratitude: "He was not a reflective man, not a thinker: he had the nature of an artist—he was, as he himself said, a 'visuel,'—a man who sees" (1893e). In February 1924, at the request of the review *Le Disque vert*, he wrote, "Of the many lessons lavished upon me in the past (1885–6) by the great Charcot at the Salpêtrière, two left me with a deep impression: that one should never tire of considering the same phenomena again and again (or of submitting to their effects), and that one should not

mind meeting with contradiction on every side provided one has worked sincerely” (1924a).

ALAIN DE MIJOLLA

See also: Bernheim, Hippolyte; Cécilie M., case of;

### **Bibliography**

- Didi-Huberman, Georges. (2003). *The invention of hysteria: Charcot and the photographic iconography of the Salpêtrière* (Alisa Hartz, Trans.). Cambridge: MIT Press.
- Ellenberger, Henri F. (1970). *The discovery of the unconscious. The history and evolution of dynamic psychiatry*. New York: Basic Books.
- Freud, Sigmund. (1893e). Charcot. *SE*, 3: 7–23.
- . (1924a). Letter to “Le Disque Vert,” *SE*, 19: 290–290.
- Gauchet, Marcel, and Swain, Gladys. (1997). *Le Vrai Charcot*. Paris: Calmann-Lévy.
- Mijolla, Alain de. (1988). Les lettres de Jean-Martin Charcot à Sigmund Freud, 1886–1893. Le crépuscule d’un dieu. *Revue française de psychanalyse*, 52 (3), 703–726.

## **CHENTRIER, THÉODORE (1887–1965)**

Théodore Chentrier, a French psychoanalyst, was born in Marseille on November 18, 1887, and died in Montreal on July 3, 1965. A fellow student with Charles de Gaulle and Georges Bernanos at the Jesuit school of the Immaculate Conception in Paris, he began his career teaching French and Latin. A man with an inquisitive mind, Chentrier took an interest in homeopathy, morphology, graphology, and psychopedagogy, which he practiced starting in 1927 while working for Professor Laignel-Lavastine and Doctor Vinchon at the Hôpital de la Pitié in Paris. He began his analysis with Rudolph Loewenstein on July 3, 1931, and became a member of the Société Psychanalytique de Paris (Paris Psychoanalytic Society) in 1933. A friend of Paul Jury, he practiced with him in Paris from 1944 to 1948, the year he left for Quebec.

Appointed professor of psychology at the University of Montreal in October 1948, for three years he was president of the Société de Psychanalyse de Montréal (Montreal Society for Psychoanalysis). He developed a widespread reputation from his broadcasts on Radio Canada known as “Psychologie de la Vie Quotidienne”

(The Psychology of Everyday Life), an extension of his conversations with Paul Jury. The series lasted for nine years.

ANDRÉ MICHEL

See also: Canada.

### **Bibliography**

- Chentrier, Théodore (1981). *Vivre avec soi-même et avec les autres* (M. Hoffman, Ed.). Montreal: La Mortagne.
- . (1984). *Un art de vivre* (M. Hoffman Ed.). Montreal: La Mortagne.
- Chentrier, Théodore and Jury, Paul (1948, April–May). La culpabilité: quelques précisions et quelques questions. *Psyché*, 18–19.

## **CHERTOK, LÉON (TCHERTOK, LEJB) (1911–1991)**

A French psychiatrist and psychoanalyst of Russian origin, Léon Chertok (Lejb Tchertok) was born October 31, 1911, in Lida (a Byelorussian city near Vilnius, Lithuania) and died July 6, 1991, in Deauville, France. Because of the educational quotas for Jews in Poland, Chertok studied medicine in Prague, where he defended his dissertation in 1938. On his way to America to escape the Nazi invasion, he stopped in France, where war broke out in 1939. He volunteered for the army, was demobilized in 1940, and entered the Resistance, where he worked mostly with the Jewish MOI section (“Main-d’oeuvre immigrée,” which brought together communist and foreign militants). Appointed to head the Mouvement National contre le Racisme (MNCR) [National Movement Against Racism], he founded the clandestine newspaper *Combat médical* and played an active role in saving Jewish children threatened with deportation. He was awarded the Croix de Guerre.

After the war his interest turned to psychiatry and he spent several months at Mount Sinai Hospital in New York City before being made a doctor of medicine in 1948 by the School of Medicine of the University of Paris. Between 1949 and 1963 he served as a resident and then an assistant at the Hospital of Villejuif, where, with Victor Gachkel, he became co-director of the Center of Psychosomatic Medicine, which they had recently created. From 1963 to 1972 he was head

of the Department of Psychosomatic Medicine at the La Rochefoucauld Psychiatry Institute in Paris, then, from 1972 to 1981, the director of the Déjerine Center for Psychosomatic Medicine, in Paris, where, with Didier Michaux, he started a hypnosis laboratory. The founder and executive secretary of the Société Française de Médecine Psychosomatique, he was also editor-in-chief of the *Revue de médecine psychosomatique*.

In 1948 he began a training analysis with Jacques Lacan, which was concluded in 1953, during the first split in the French psychoanalytic movement. In spite of supervised analyses with both Marc Schlumberger and Maurice Bouvet, Chertok the nonconformist was not admitted to the Société Psychanalytique de Paris; the fact that he made extensive use of hypnosis in his practice, becoming one of the leading specialists in France, certainly did not improve his chances of admission. His practice, and the many articles he wrote about his work, ultimately pushed him further and further from traditional psychoanalysis. Nonetheless, in 1973 he co-authored, with Raymond de Saussure, *La Naissance du psychanalyse, de Mesmer à Freud*, a historical work on the origins of Freudian psychoanalysis that has become a classic.

At the request of Philippe Bassine and A. E. Sherozia, he also organized a symposium on the unconscious held in Tbilisi, Georgia, in October 1979, which was attended by a number of psychoanalysts, including several from France. This was the first official event where psychoanalysis was openly discussed in Soviet Russia.

However, hypnosis was Chertok's true field of research and the subject of considerable thought. In 1987, toward the end of his life, his work took a new turn when he and Isabelle Stengers began a seminar entitled "L'hypnose, problème interdisciplinaire."

ALAIN DE MIJOLLA

*See also:* Hypnosis; Suggestion.

### **Bibliography**

Chertok, Léon. (1966). *Hypnosis* (D. Graham, Trans.). Oxford, New York: Pergamon Press. (Original work published 1963)

———. (1981). *Sense and nonsense in psychotherapy: The challenge of hypnosis* (R.H. Ahrenfeldt, Trans.). Oxford, New York: Pergamon Press. (Original work published 1979)

Chertok, Léon, and Stengers, Isabelle. (1992). *A critique of psychoanalytic reason: Hypnosis as a scientific problem from Lavoisier to Lacan* (Martha Noel Evans, Trans.). Stanford, CA: Stanford University Press.

Chertok, Léon, and de Saussure, Raymond. (1979). *The therapeutic revolution, from Mesmer to Freud*. (R. H. Ahrenfeldt, Trans.). New York: Brunner/Mazel.

---

## **CHICAGO INSTITUTE FOR PSYCHOANALYSIS**

The Chicago Institute for Psychoanalysis, one of the oldest in the United States, has been both a key institution in its own right and a hub for westward expansion of the profession. Founded during the Great Depression, in the 1940s the Institute served as a training and credentialing institute for analysts who then created organizations in other cities, including Topeka, Los Angeles, and Detroit. Although ultimately most closely associated with the classical ego psychology that dominated analysis at mid-century, the Chicago Institute was distinctive for a certain tolerance of divergent points of view. Its founder, Franz Alexander, promoted several unconventional ideas and techniques; Heinz Kohut, after a long career as a purely orthodox analyst, developed his influential self psychology at the institute during the 1970s. Thomas Szasz, who became an iconoclastic critic of psychiatry, originally trained at the Chicago Institute.

Organized psychoanalysis in the city dates to establishment of the Chicago Psychoanalytic Society in 1931. N. Lionel Blitzsten, the society's first president, was considered the first trained analyst in Chicago and a charming teacher who lacked administrative interests or skills. Establishment of the Chicago Institute fell to the Hungarian analyst Franz Alexander.

Alexander, who lectured at the University of Chicago in 1930 but did not receive a warm welcome among psychiatrists there, returned to the city two years later to found and become first director of the Chicago Institute for Psychoanalysis. His objective was to create a training center outside a university setting that could also support research and clinical activities. A charismatic figure originally attached to the Berlin Psychoanalytic Institute, Alexander became a magnet for other European analysts, especially with the rise of German fascism. Alexander modeled the center on the Berlin Institute, which itself had been founded along



the lines of the great nineteenth-century research institutes designed to encourage intellectual exchange, debate, and collaboration. The Chicago Institute had a brick-and-mortar presence from the beginning and boasted classrooms, a library, and a dining room where staff lunches became an enduring feature, as they had in Berlin.

The organizational structure that Alexander established at Chicago was in certain respects unique. He proved able to attract wealthy donors, some among his analysts, and early funding was provided by Alfred K. Stern, an executive with the Julius Rosenwald Fund, a Chicago-based philanthropy, and by the Rockefeller and Macy Foundations. Alexander created a lay board of trustees with fiscal responsibility for the institute, which became a powerful source of funding, especially during the heyday of psychoanalysis. In addition, the institute was staffed by a small group of analysts with lifetime appointments and, in organizational terms, was entirely separate from the Chicago Psychoanalytic Society. This arrangement is thought to have promoted the tolerance for divergent points of view that helped Chicago avoid the splits so common in psychoanalytic institutes in other cities.

Alexander directed the Chicago Institute for the best part of a quarter century. As an administrator he was regarded as authoritarian, albeit a benign despot, while he and the analytic staff functioned as an oligarchy. Alexander's research, for which he secured large grants from the Rockefeller Foundation, was a considerable stimulus to psychosomatic medicine, which, although later engulfed by molecular psychiatry and other developments, came to enjoy a high profile by the 1950s. Also involved in research were Thomas M. French, until 1961 the institute's director of research, and the German analyst Therese Benedek, the author of a major text on psychoanalytic supervision and one of a number of prominent female analysts at Chicago.

In 1953, Alexander decided to leave the institute and he spent the last phase of his career in Los Angeles, until his death in 1964. To some extent his departure was a consequence of the advancing orthodoxy at Chicago that viewed Alexander's innovative treatment options, such as analysis only three times per week and the concept of a "corrective emotional experience," as out-of-step with techniques then in vogue.

Gerhart Piers effectively succeeded Alexander in 1956, for what became a fifteen-year administration.

He exercised power much as Alexander had done and used his influence to reengineer the training institute and introduce several other innovations, including a low-fee graduate clinic. He also paid greater attention to therapy for children and adolescents, an area that Alexander had neglected. Piers organized the Child Therapy Training Program for pediatricians, nurses, and social workers and, in 1965, developed a Teacher Education Program.

To Heinz Kohut, a recent graduate of the institute, Piers entrusted the task of reorganizing and revamping the curriculum. Kohut, who then worked closely with the forces shaping ego psychology, created a core set of classes with a historical perspective, and went on to teach the two-year theory course himself for many years. As was the case at other institutes, the new curriculum at Chicago paid little attention to the work of Melanie Klein or the British analysts who were then developing object relations theory.

Although George Pollock, who succeeded Piers in 1971, became a controversial figure late in his tenure, he was an energetic director who moved the Chicago Institute with a multi-pronged agenda. As a major administrative figure in both the American Psychoanalytic Association and the American Psychiatric Association, he raised the profile of the Chicago Institute through the effective exercise of power, though some thought his actions were based too much on a patronage-like system. In 1973, he engineered authorization from the State of Illinois for the institute to offer a doctoral program in psychoanalysis. The same year, the *Annual of Psychoanalysis* began publication and became an influential yearly review. Pollock also established the Barr-Harris Children's Grief Center, which remains in operation today, to help children cope with the loss of a parent or sibling. Research meetings at the Institute regularly drew renowned analysts as speakers, and although analysis would soon to lose much of its privileged cache to biological psychiatry, Charles B. Strozier wrote (2001), "I doubt there has been a more lively intellectual atmosphere in the history of psychoanalysis than at the Chicago Institute in the 1970s."

While Chicago remained Heinz Kohut's base throughout his career, his innovative brand of psychoanalysis was not warmly received by either Pollock or many of his colleagues at the institute. However, Kohut's deemphasis on drive theory and his view that narcissism was a separate developmental path did win

adherents—Arnold Goldberg, Charles B. Strozier, and Ernest Wolf at Chicago—and self psychology eventually established itself as a branch movement within psychoanalysis. Kohut died relatively young, at age sixty-seven in 1981, just ten years after publication of his *The Analysis of the Self*.

Although Pollock liberalized the oligarchic character of the institute's staff and was a successful fundraiser through the lay board of directors, he could not stem the effects of a nationwide decline in the popularity of analysis as it ceased to attract large numbers of psychiatrists and patients. In 1988, after Pollock was sued by the son of a patient who claimed that his mother, a wealthy donor to the institute, had been financially exploited, he resigned. Subsequent reorganization in the wake of his acrimonious departure favored greater pluralism and more power extended to the faculty. Both Arnold Goldberg, who became next director in 1989, and Thomas Pappadis, who succeeded him in 1992, brokered policies that further democratized the institute. Jerome Winer, named director in 1998, continued to broaden the focus of the institute while attempting to enhance funding and to further cooperative ventures with universities.

As was the case in other cities, the Chicago Institute for Psychoanalysis survived the recalibration of analysis as a therapy and profession by creating for itself a place within the larger context of mental health practice. While the Chicago Society for Psychoanalysis, still a separate body, is comprised primarily of medically trained analysts, the Chicago Institute serves a broader community with a more inclusive mandate. In the early 2000s, the institute provides training programs for physicians, psychoanalysts, social workers, and other professionals, and offers clinical and community services in a variety of venues for children, adolescents, and adults.

JOHN GALBRAITH SIMMONS

### **Bibliography**

- Kavka, J. (1984). Fifty years of psychoanalysis in Chicago: A historical perspective. In G. Pollock and J. Gedo (Eds.), *Psychoanalysis: The vital issues* (Vol. II, pp. 465–93). New York: International Universities Press.
- Pollock, George H. (1978). The Chicago Institute for Psychoanalysis from 1932 to the present. In J. Quen and E. Carlson (Eds.), *American psychoanalysis: Origins and development* (pp. 109–26). New York: Brunner/Mazel.

- Strozier, Charles B. (2001). *Heinz Kohut: The making of a psychoanalyst*. New York: Farrar, Straus and Giroux.

## **CHILD ANALYSIS**

The term *child analysis* refers to the application of psychoanalytic treatment and concepts to a child with a view to understanding the psychic life and mental development of children.

The notion of child analysis first appeared in the work of Melanie Klein, in the sense that she first provided an extensive definition that is both theoretical and practical. The pioneers in the field include Sándor Ferenczi, who contributed still-original ideas on the confusion of tongues between adult and child, as well as his account of the treatment of Little Arpad, and Alfred Adler, one of the first practitioners of child analysis in Vienna.

Hermine von Hug-Hellmuth was one of the first child psychoanalysts to use play techniques, but it was only with Klein that the notion of transference and the idea of psychoanalytic treatment for children appeared. This perspective placed her in sharp opposition to Anna Freud, who believed that transference did not really exist for children owing to the parents' place in the child's life. In contrast, Klein used the transference for the "deep" interpretation of hate and envy. This controversy left its imprint on the evolution of psychoanalysis in Great Britain and led to the creation of the Independent group, which consistently upheld the importance of childhood development.

In relation to adult psychoanalysis, child psychoanalysis occupies an indeterminate position that is both peripheral and central, and that is reflected in debates about the various modes of psychoanalytic training throughout the world. It is peripheral in that not all adult analysts have the inclination or training to work with children, and not all psychoanalytic societies require that their candidates have specific training or even knowledge of the elements of mental development. It is central in that the fundamental concepts of psychoanalysis are summed up in the child: infantile sexuality, transference, the unconscious, resistance, repetition, the drives, and interpretation. The case of Little Hans, described by Sigmund Freud in "Analysis of a Phobia in a Five-Year-Old Boy" (1909b) is a good example of this, even though the treatment was essentially based on observations and exchanges

between Hans and his parents, in a sort of precursor to treatment proper.

In this sense, child analysis can be seen as the application of psychoanalysis in all its facets. In fact, it has not been limited to the treatment of neuroses, but has rapidly been extended to various forms of psychosis, autism, mental retardation, childhood psychosomatic disorders, the psychoanalytic observation of infants, and ethnopsychanalysis. Donald W. Winnicott applied Klein's thinking and his own pediatric experience to a psychoanalytic approach to infants and their relational and developmental difficulties, in particular the encroachment of maternal depression on the infant's self. From this he derived a model for treating borderline states in adults.

In France, Sophie Morgenstern is credited with the first psychoanalytic use of a child's drawing. In 1958 Jacques Lacan gave an original description of the development of subjectivity in the infant, based on the notion of the mirror stage and using the concepts of privation, frustration, and castration, along with the concepts of the Real, the Symbolic, and the Imaginary. Françoise Dolto contributed a great deal to the popularization of child analysis through her analytic and pedagogical talents, and proposed the notion of the unconscious body image. Serge Lebovici, René Diatkine, Michel Soulé, Roger Misès, and Janine Simon were among the analysts most actively involved with children, through institutions that they created, such as the CMPP. (Consultations médico-psychopédagogiques [Medical and psycho-pedagogical consultations]), as well as through studies on the specific requirements of child analysis, its technique and training. Together with Michel Fain and Léon Kreisler, and working within a perspective close to that of René Spitz, Michel Soulé helped define the field of psychosomatic psychoanalytic work with infants, children, and adolescents.

ANTOINE GUEDENEY

*See also:* Infantile neurosis.

### **Bibliography**

- Diatkine, René, and Simon, Janine. (1972). *La psychanalyse précoce*. Paris: Presses Universitaires de France.
- Dolto, Françoise. (1984). *L'image inconsciente du corps*. Paris: Le Seuil.

Freud, Sigmund. (1909b). Analysis of a phobia in a five-year-old boy. *SE*, 10: 1–149.

Klein, Melanie. (1975). The psycho-analysis of children. In *The Writings of Melanie Klein* (Vol. 2). London: Hogarth. (Original work published 1932)

Kreisler, Léon; Fain, Michel; and Soulé, Michel. (1974). *L'enfant et son Corps*. Paris: Presses Universitaires de France.

---

## **CHILDHOOD**

Childhood is not a Freudian concept. A large part of psychoanalytic theory concerns the early years of life and childhood but, in a certain sense, we can say along with Donald Winnicott that “Freud neglected childhood as a state in itself” (1961).

Only after a wrenching period of revision (1895–1901) could Sigmund Freud come to acknowledge the active role of the child in sexual seduction and to abandon his earlier view of children as innocent victims of the incestuous desires of adults; this reversal, moreover, led him to theorize childhood sexuality for the first time. “In the beginning,” he would later write, “my statements about infantile sexuality were founded almost exclusively on the findings of analysis in adults which led back into the past. I had no opportunity of direct observations on children. It was therefore a very great triumph when it became possible years later to confirm almost all my inferences by direct observations and the analysis of very young children” (1914d).

It was in connection with the treatment of adults that Freud became interested in observing small children. As he wrote apropos of the case of “Little Hans,” “I have for years encouraged my pupils and friends to collect observations on the sexual life of children, which is normally either skillfully overlooked or deliberately denied” (1909b). Freud indeed never abandoned this line of enquiry, as witness his celebrated account of the “*Fort/Da*” game played with a cotton reel by one of his grandsons, the personal observation of which he used to support his theoretical conclusions. As related in *Beyond the Pleasure Principle* (1920g), the fact that an act provoking unpleasure would be repeated, coupled with clinical findings from his treatment of traumatic neuroses, was what led Freud to formulate the concept of the death instinct.

After the publication of the *Three Essays on the Theory of Sexuality* (1905d), the first generation of analysts

began observing and reporting on the behavior of their own children in reference to infantile sexuality, the Oedipus complex, and castration anxiety. Anna Freud shared in this activity (Geissmann and Geissmann, 1992). Soon these analysts were joined by specialists on child behavior who had themselves been analyzed. They began to observe specific populations of disturbed children, such as delinquents, then certain periods of childhood, notably that of the earliest mother-child relations, and finally certain types of problems encountered (feeding, thumb-sucking, attempts at separation, etc.). In so doing they were “systematically constructing a psychoanalytic psychology of the child, integrating two kinds of data: data based on direct observation and data based on reconstructions with adults” (Freud, 1968).

It is important to note, along with Anna Freud, that psychoanalysts at first showed considerable reluctance to undertake such direct observation of children. The pioneers were more concerned to underscore the differences between observable behavior and hidden drives than they were to point up the similarities. Their chief aim was still to show that manifest behavior concealed unconscious processes. Anna Freud was initially interested in the defense mechanisms, which became accessible to an observational approach; she then turned her attention to children’s behavior, to what they produced, and, lastly to the child’s ego. She sought to include a psychology of the ego within the analytic framework, an effort further developed later by her friend Heinz Hartmann, whom she never completely disavowed.

On a practical level she created institutions for young children, the first in Vienna in 1924–1925, the last and most complex, which was established after the war in London, being the Hampstead Clinic, an extension of Hampstead Nurseries. At the end of her life she trained child specialists at Hampstead Clinic who worked within the framework of a psychoanalytic psychology of childhood. This work involved treating the child—not only with analysis—to prevent further disturbances, conducting research, and training future specialists in children’s education and pedagogy by applying previously acquired knowledge.

During this same period, Melanie Klein also became interested in childhood. She did not base her theories on direct observation, however. Starting from the psychoanalysis of young children, she constructed a detailed picture of the internal world of the young

child. She pioneered the use of play in analysis. Like dream interpretation for Freud, the free play of the child was for Klein the royal road to the unconscious and to the fantasy life. In *The Psychoanalysis of Children* (1932), she argued forcefully that play translated the child’s fantasies, desires, and lived experience into a symbolic mode. Her technique consisted in analyzing play just as one would analyze dreams and free association in adults, that is, by interpreting fantasies, conflicts, and defenses. The inner world of the young child as she describes it is filled with monsters and demons, and the picture of infantile sexuality she presents is strongly tinged with sadism. In discussing the death drive, she describes an infant whose first act is not simply a gesture of pure love toward the object (breast) but also a sadistic act associated with the action of the drive. Here, as Freud had earlier, Klein challenged a universal human shibboleth: the innocent soul of the child. This was one of the reasons why her work was often poorly received.

The direct observation of young children has expanded considerably in recent years, helped in part advances in technology: it is now possible to study newborns and even fetuses. It is interesting to note that, in this way, the significance and the complexity of the mental life of the very young child have been confirmed, along therefore with the intuitions and efforts of psychoanalysts working during the early twentieth century.

It is clear that psychoanalysis has renewed our vision and understanding of the world of childhood. However, that world remains highly complex, especially its pathology, and it is important to avoid seeing it in terms of adult behavior. Also, while psychoanalysis has enabled us to better understand that world, we must remember, as Anna Freud remarked at the end of her life, that it does not have the power to eliminate childhood neuroses and turn the child and childhood into that place where we would so much love to find innocence, the mythical innocence of a paradise lost.

CLAUDINE GEISSMAN

See also: *Childhood and Society*; Children’s play; Fort-Da; Klein-Reizes, Melanie; Winnicott, Donald Woods.

### **Bibliography**

Freud, Anna. (1966). *Collected writings*. New York: International Universities Press.

Freud, Sigmund. (1905d). Three essays on the theory of sexuality. *SE*, 7: 123–243.

———. (1909b). Analysis of a phobia in a five-year-old boy. *SE*, 10: 1–149.

———. (1914d). On the history of the psycho-analytic movement. *SE*, 14: 1–66.

———. (1920g). Beyond the pleasure principle. *SE*, 18: 1–64.

Geissmann, Claudine and Geissmann, Pierre. (1992). *A history of child psychoanalysis*. New York: Routledge.

Klein, Melanie. (1975). The psycho-analysis of children. In *The Writings of Melanie Klein* (Vol. II). London, Hogarth. (Original work published 1932)

Winnicott, Donald. (1965). The theory of infant-parent relationship. In *The maturational processes and the facilitating environment*. (pp. 17–55). London: Hogarth. (Original work published 1962)

---

## CHILDHOOD AND SOCIETY

This book by Erik Erikson, published in 1950, is a classic because it was one of the first to show how Sigmund Freud's theory of infantile sexuality could be broadened in the light of fieldwork in cultural anthropology and sociological studies.

Erikson studied two American Indian tribes and compared their different ways of socializing children. Based on this work he elaborated his conception of the development of the ego, in which he discerned eight distinct phases that he believed were an aspect of psychology at least as important as the libidinal stages outlined by Freud. Attempting to identify positive, organizing aspects of the psyche, Erikson sought to show how these achievements of the ego continue to change and exert an influence long after the conflicts of early childhood that had so interested Freud.

Erikson was particularly interested in problems relating to youth, above all the ways in which psychosocial identity could be a key organizing concept for understanding adolescence. He approached this issue from a cultural-comparatist perspective, with a special focus on the characteristic polarities of American society. He then studied the legendary characteristics of Adolf Hitler's childhood to see how the rise of Nazism could be interpreted within the framework of typically German social structures. Lastly, Erikson interpreted what is known about Maxim Gorky's

youth, to complement his description with materials taken from Russian history.

Revised and expanded in 1963, *Childhood and Society* is the work of a pioneer who sought to raise psychoanalytic thought to the level of the modern social sciences. Although he did not renounce his early Freudianism, Erikson endeavored to provide a new way of looking at things. When asked what the aims of a normal individual should be, Freud customarily replied with two words that Erikson liked to recall: "Love and work." Erikson wanted such a maxim to become a psychoanalytic norm.

PAUL ROAZEN

See also: Anthropology and psychoanalysis; Erikson, Erik (Homburger); Ego (ego psychology).

### Source Citation

Erikson, Erik H. (1950). *Childhood and society*. New York: Norton.

### Bibliography

Friedman, Lawrence J. (1999). *Identity's Architect: A biography of Erik H. Erikson*. New York: Scribner's.

Paul Roazen. (1976). *Erik H. Erikson: The power and limits of a vision*. New York: The Free Press.

---

## CHILDREN'S PLAY

In psychoanalysis, "children's play" is mental and physical activity which gradually becomes more structured in the course of a child's development. This activity bears witness to a psychic capacity for "concentration" within a personal mental sphere of illusion where objects and phenomena in the external world are transformed in accordance with the subject's wishes, so serving the internal world and augmenting pleasure.

For Freud (1905d, 1905c, 1908e, 1911b), children's play, being subject to the pleasure principle, stood opposed to the constraints of critical thought and reality. The opposite of play is not seriousness but reality, even if children like to prop their imaginary objects on visible, tangible ones. Such propping is precisely what distinguishes playing from fantasizing; as the child

grows up, it is left behind. In *Beyond the Pleasure Principle* (1920g), Freud told how he observed his one-and-a-half-year-old grandson repeating in an active way—by making a wooden reel attached to a string alternately disappear and reappear—what he had had to experience passively, namely the departure of his mother; the pleasure derived from this game allowed the child to work over the unpleasurable experience of his mother's absence. In Freud's view, the compulsion to repeat that operated "beyond the pleasure principle" and the child's tendency to seek immediate pleasure through play were intimately linked. Today it is felt that play indeed helps the child tolerate the absence of an object, that it implies the cathexis of a representation: the boy with his reel successfully converts absence into nostalgia.

Melanie Klein was a closer student of the use of play in child psychoanalysis than of the phenomenon of play per se. Following Hermine Hug-Hellmuth, she devised a technique of play interpretation that treated the ordering of children's play as equivalent to the adult's production of associative material in analysis. She was thus able to apply the Freudian method to very young children, opening the way to child psychoanalysis (Klein, 1955).

Donald Woods Winnicott offered an original account of the notion of "play" and incorporated it into psychoanalytic theory. Since play was not subsumed under the sublimation of instincts, Winnicott speculated that a space existed between the mother and her baby: since the mother (or her substitute), motivated by love (or hate) and not by reaction-formations, needed to be able to adapt actively to her baby's needs, to be what the baby was capable of finding while also leaving the baby the time to find her, a realm of illusion emerged in which the infant felt omnipotent (the breast being under its magical control); such feelings of omnipotence were necessary if the infant was going gradually to accept the disillusion to come. According to Winnicott, the intermediate area between mother and infant was occupied by "transitional phenomena"—groups of functional experiences, as for example thumb-sucking, the holding and sucking of the edge of a blanket, a repeated gesture, or the production of musical sounds (Winnicott, 1974, p. 4)—and it arose between the period of primary creativity and that of objective perception founded on reality-testing. The "transitional object," created internally though found in the outside world, would be the first tangible sign of the existence

of this intermediate zone where the question whether experience was of external or of internal origin simply did not arise. Transitional objects lay "between me and not-me."

There is a direct progression, in the Winnicottian perspective, from transitional phenomena to play, from the child's ability to play alone in the presence of another person to the ability to play a game with others—at first with the mother and only later with peers. Until the age of five or six, children play alongside one another rather than with one another, as Anna Freud showed in her discussion of lines of development. Play involves the body, and the pleasure derived from the functioning of the ego in play activity requires that neither excitement nor anxiety be too intense; children's play is a precarious achievement within the area between subjectivity (not to say hallucination) and objective perception. The capacity for play, once successfully acquired, will endure in every kind of inner experimentation, in the life of the imagination and in adult creativity, although, beginning at the latency period, the individual must become capable of suspending play activity.

NORA KURTS

*See also:* Active imagination (analytical psychology); Activity/passivity; *Beyond the Pleasure Principle*; Breast, good/bad object; Child analysis; Childhood; "Creative Writers and Day-Dreaming"; Creativity; Fantasy (reverie); Fort-Da; Humor; Illusion; Infant observation (therapeutic); Jokes; Magical thinking; Metaphor; Object *a*; Visual arts and psychoanalysis; Pleasure/unpleasure principle; *Psycho-Analysis of Children, The*; Rambert, Madeleine; Richard, case of; Squiggle; Technique with children, psychoanalytic; Transitional object, space; Transitional object; Transitional phenomena; Unconscious fantasy.

### **Bibliography**

- Freud, Sigmund. (1905c). Jokes and their relation to the unconscious. *SE*, 8: 1–236.
- . (1905d). Three essays on the theory of sexuality. *SE*, 7: 123–243.
- . (1908e). Creative writers and day-dreaming. *SE*, 9: 141–153.
- . (1911b). Formulations on the two principles of mental functioning. *SE*, 12: 213–226.
- . (1920g). Beyond the pleasure principle. *SE*, 18: 1–64.

- Klein, Melanie. (1955). The psycho-analytic play technique: Its history and significance. In *Envy and gratitude and other writings, 1946–1963* (The Writings of Melanie Klein, vol. 3), London: Hogarth/Institute of Psycho-Analysis.
- Kurts, Nora. (1993). L'Enfant qui ne savait pas jouer. *Psychiatrie de l'Enfant* 36, no. 2, pp. 537–554.
- Lebovici, Serge, and Diatkine, René. (1962). Fonction et signification du jeu chez l'enfant. *Psychiatrie de l'Enfant* 4, 207–253.
- Winnicott, Donald W. (1974). *Playing and reality*. Harmondsworth, England: Penguin.

### Further Reading

- Furman, Erna. (1990). Play and work in early childhood. *Child Analysis*, 1, 60–76.
- Klein, Melanie. (1929). Personification in the play of children. *International Journal of Psychoanalysis*, 10, 193–204.

## CHILE

The Chilean doctor Germán Greve Schlegel (1869–1954) was the first to publish on the subject of psychoanalysis in Chile and, in general, in Latin America. His study, *Sobre psicología y psicoterapia de ciertos estados angustiosos* was presented in Buenos Aires in 1910. Sigmund Freud (1911g, 1914) wrote about the event in the *Zentralblatt für Psychoanalyse* and in his *On the History of the Psychoanalytic Movement*.

The true pioneer, however, was Fernando Allende Navarro (1890–1981), the first Chilean psychoanalyst. Born in Concepción, Allende Navarro studied medicine in Belgium and completed his doctorate in Switzerland in 1919. He specialized in neurology and psychiatry, studying with von Monakow, Rorschach, and Veragout. He began his psychoanalytic training in Switzerland and became a member of the Société Suisse de Psychanalyse [Swiss Society for Psychoanalysis] and the Société Psychanalytique de Paris [Paris Psychoanalytic Society]. Upon his return to Chile in 1925, he presented his dissertation—“El Valor de la psicoanálisis en la policlinica: Contribución a la psicología clínica”—at the University of Chile.

The consolidation of the psychoanalytic movement began in 1943 with the return of Ignacio Matte-Blanco (1908–1994) and culminated in 1949 during the international congress in Zurich, with the recognition of

the Asociación Psicoanalítica du Chili [Psychoanalytic Association of Chile] by the International Psychoanalytic Association. Matte-Blanco was born in Santiago and studied medicine at the University of Chile. In 1933 he left for London, where he trained in neuropsychiatry at Northumberland House and at Maudsley Hospital. He received his psychoanalytic training at the British Institute. He did his training analysis with Walter Schmideberg and his control analysis with Anna Freud, Melitta Schmideberg, Helen Sheehandare, and James Strachey. In 1940 he went to the United States to work at Johns Hopkins Hospital and, between 1941 and 1943, was assistant professor of psychiatry at Duke University. Upon his return to Chile he trained and analyzed a group of individuals interested in psychiatry and psychoanalysis; these men and women worked under the auspices of the Psychiatric Clinic of the University of Chile. In 1949 he was appointed professor and chair of psychiatry, which gave considerable impetus to the group but was not without complications because of the overlapping roles and responsibilities entailed.

The period was characterized by numerous activities and publications and an overall modernization of the field of psychiatry in Chile. It reached its apogee in 1960, during the third Latin American Congress of Psychoanalysis held in Santiago. The group's orientation was toward classical psychoanalysis, but it was open to new developments, many of which were inspired by work in anthropology and philosophy. Matte-Blanco published *Lo Psíquico y la Naturaleza humana* in 1954 and *Estudios de psicología dinámica* in 1955, books that contained the core ideas he would later develop in Rome and which were published in 1975 in *The Unconscious as Infinite Sets: An Essay in Bi-logic* and in 1989 in *Thinking, Feeling and Being: Clinical Reflections on the Fundamental Antinomy of Human Beings in the World*.

There was also interest in clinical research, which was reflected in a precocious psychoanalytic investigation of the field of psychosis and perversion, primarily in the work of de Ganzaraín and Whiting.

This first generation of psychoanalysts included Arturo Prat (1910–1989), Carlos Whiting (1918–1982), Erika Bondiek, Carlos Nuñez (1918–1983), Ramón Ganzaraín, and Hernán Davanzo; they were followed by José Antonio Infante, Otto Kernberg, Ximena Artaza, and Ruth Riesenber.

Important changes occurred after 1961. Because of operational difficulties and outside influences, the majority of analysts abandoned work in clinical settings and rejected the leadership of Matte-Blanco, focusing instead on the association as an independent institution. Between 1962 and 1971 several well-known members emigrated to Europe or the United States, including Matte-Blanco himself, who settled in Rome in 1966. There followed a general weakening of the movement, although training continued at more or less the same rate. There were exchanges within Latin America, and David Liebermann was called to Buenos Aires on several occasions. The connection to the universities was maintained by Professors Hernán Davanzo, Mario Gomberoff, Omar Arrué, and their staffs. The association itself became increasingly Kleinian.

In the eighties there was a sustained development in the psychoanalytic movement in Chile. Several generations of analysts were trained by Artaza, Bondiek, Davanzo, Eva Reichenstein, and Infante, who had returned from Topeka in 1978. Frequent visits by those who had emigrated, including Otto and Paulina Kernberg, Ramón Ganzarain, and Ruth Riesenber, had an invigorating effect on the profession. Access of this third generation of analysts to training and guidance within the association, together with the association's work with scientific and cultural organizations, led to the growth of a renewed psychoanalytic movement, one that was more pluralist and open to change. A number of psychoanalysts from this period stand out: Mario Gomberoff, Liliana Pauluan, Elena Castro, Omar Arrué, Ramón Florenzano, Jaime Coloma, Eleonora Casaula, Juan Francisco Jordán, and Juan Pablo Jiménez. The Argentinians Horacio Etchegoyen, Jorge Olagaray, and Guillermo Brudny provided significant contributions to the movement. The association's official publication is the *Revista chilena de psicoanálisis*.

OMAR ARRÚE

### Bibliography

- Arrué, Omar. (1988). Cuarenta años de psicoanálisis en Chile. *Revista chilena de psicoanálisis*, 7 (1), 3–5.
- . (1991). Orígenes e identidad del movimiento psicoanalítico chileno. In E. Casaula, J. Coloma, and J.-F. Jordán (Eds.), *Cuarenta años de psicoanálisis en Chile*. Santiago: Ananké.
- Casaula Eleonora, Coloma Jaime, and Jordán, Juan Francisco (Eds.). (1991). *Cuarenta años de psicoanálisis en Chile*, Santiago: Ananké.
- Davanzo, Hernán. (1993). Orígenes del psicoanálisis en Chile. *Revista chilena de psicoanálisis*, 10, 58–65.
- Whiting, Carlos. (1980). Notas para la historia del psicoanálisis en Chile. *Revista chilena de psicoanálisis*, 2 (1), 19–26.

## CHINA

Unlike in Japan and Korea, psychoanalysis in China has had a relatively checkered history. Freud's ideas achieved some notoriety in the 1920s during a period of significant social and political reform but were otherwise not taken seriously until the 1930s when the first translations began to appear. To this day, only a handful of Freud's works have been translated into Chinese.

Early translations resulted in some distortions of the original ideas for several reasons. There has been a tendency for translators to directly borrow the Japanese terminology as the two languages share a common writing system in kanji—characters, even though the same characters may mean different things in the two languages. This has produced occasional errors, as, for example, with China's initial use of the Japanese term *muisiki* for “Unconscious”, which literally means, in Chinese, “without consciousness.”

More systematic distortions were also evident. There was concern in some quarters that Freud's theory, which appeared to grant primacy to a free-reigning sexuality, could be construed as a threat to the stability of family relations. Some interpretations of the Oedipus complex were desexualised, emphasizing a social component. The female author Yonqin, writing in 1930 about Freud's theory of hysteria (and omitting all references to infantile sexuality), stated that the condition arises out of conflict between social pressure and the “biological instinct for satisfaction and fulfilment.” A motive for translating Freud, in one translator's eyes, was to forewarn a general public of the dangers of taking Freud too seriously (Zhang, 1989).

By contrast, very serious attempts have been made to rethink the oedipal myth in terms of culturally prevalent myths. In China the myth of *Hsueh Jen Keui* tells of a soldier of the Tang dynasty who kills his own son in ignorance of the kinship tie, preserving the authority of the father; some commentators have held that this becomes an exemplar of the Confucian ethic of filial piety (Zhang, 1989).



Sometimes translations of psychoanalytic and scientific articles based upon primary sources were written with a clear political purpose. The May Fourth movement of 1919 had heralded a brief renaissance in which there had been increasing call from intellectuals to modernize China and shake off certain feudalistic practices and “superstitions.” Freudian notions of sexual tension in families proved compelling to those calling for social reform. Freudian ideas could be claimed to be useful because of their allegiance to biology, medicine and education.

As several commentators have amply documented, psychiatry, as a separate discipline, was in its infancy in China before 1949. There was a home for the mentally ill in Canton which opened in 1898 run by an American missionary doctor. Before that there appears to have been little in the way of psychiatric services. By the time the Communist Party came to power a small number of psychiatric hospitals appeared in the major cities where foreign influence was quite high. The most significant was the Peking Union Medical College which launched the first full-scale academic program in 1932 with new initiatives in teaching and practice involving the disciplines of sociology and social work.

However, psychoanalysis as therapy has not easily taken root in China. This is because, it has been argued, there has been no tradition of expressiveness in the doctor-patient relationship and the doctor in a traditional Chinese setting adopts an authoritarian attitude towards patients. Before WWII there had been only one Chinese psychoanalyst, Bingham Dai, who trained under Harry Stack Sullivan and taught psychotherapy at Peking Municipal Psychopathic Hospital (allied to the Peking Union Medical College) from 1935–39. While he was of the view that, but for the Japanese invasion, psychoanalysis might have taken root in China, he downplayed the theoretical importance Freud attached to the instinctual impulses, claiming that Chinese clinicians emphasised interpersonal relations, and gave more attention to helping their patients tackle the problems of being human (Blowers, 2004).

One should also note that Chinese typically present psychological problems as somatic complaints and have deeply ingrained philosophical systems of thought for which traditional practices such as worshipping of ancestors and visits to the temple to seek one’s fortune serve in times of distress.

These practices have been understood by Unschuld (1980, cited in Gerlach, 1995) as embodying a “Medicine of parallels,” evolving out of Confucianism, Taoism and Buddhism in which “visible and invisible occurrences in the internal and external worlds of the human being (e.g. emotions, internal organs, climatic conditions, elements) are allocated to particular series of parallels and are mutually dependent on each other. Thus the dividing lines between internal and external, mind and body, are removed and a change in one link in the series of parallels will directly affect the others” (Gerlach, p. 94). These systems of thought have also been influenced by turbulent political events. After the founding of the People’s Republic of China (PRC) in 1949, the Communist government severed all ties with non-Communist countries. Attention became focused on Russia. In the early part of its first decade, all psychological work in the PRC was based upon Russian psychology and followed Pavlov’s work very closely. When this model proved less than satisfactory for explaining all psychological phenomena, there then followed two very difficult periods in which psychology was criticised and eventually shut down along with many other disciplines in the second of these periods that became known as the “Proletariat or Cultural Revolution”. Only since 1978 has psychology emerged with a new agenda, largely free of previous political constraints.

During the 1980s visiting psychoanalysts to China (Joseph, 1987) formed the impression that, insofar as psychotherapeutic methods are applied, they are oriented to behavioral therapy or use supportive techniques. They argued, however, that this circumstance maybe connected with traditional Chinese cultural patterns, which discourage both disclosure and communication about one’s own feelings and thoughts to strangers and openness to sexual desires. Insight-oriented psychotherapies face obstacles both in the traditional pattern of Chinese thought and in conflicts leading to feelings of shame more than guilt. However, there have been substantive changes since the 1980s, both in the doctor-patient relationship and in the status of psychoanalytically oriented psychotherapy, in several of China’s key cities.

In spite of there being no analysts in the early years of the PRC, by the 1990s things began to change. The German-Chinese Academy for Psychotherapy (GCAP), comprising German family therapists, behavioral therapists, and psychoanalysts under its president, Margarethe Haass-Wiesegart, initiated a range of training

programs covering behavioural, systemic and psychoanalytic trends. From 1997–1999 they began a continuous training program of six-week courses in Kunming, Beijing, Shanghai, Wuhan, and Chengdu; the curriculum consisted of psychoanalytically oriented psychotherapy. The analysts involved in this training were Antje Haag, Margarethe Berger and Alf Gerlach, the latter having first lectured in China in the 1980s. A second program was initiated in 2000 in Shanghai and Hefei.

Since 1995 the IPA has also begun reaching out to China, organising a committee for Asia, with China represented by Argentinean-trained Teresa Yuan, of Chinese descent. She began training programs at Beijing Anding Psychiatric Hospital, attended by professionals from universities in Beijing and other Chinese cities. Psychoanalytic psychotherapy has been taught in a variety of psychiatric settings in the above mentioned cities, as well as in Xian, Guangzhou, Nanjing and Hong Kong. Huo Datong, a Chinese analyst trained with a Lacanian orientation in France, recently founded a psychoanalytic center in Chengdu (Yuan, 2000).

Although these developments signal a promising outlook for psychoanalytic methods and their application in China, the range and complexity of Freud's ideas may not be fully appreciated unless and until translation revisions and translation of more of his works are undertaken, clinical psychology gets more firmly established, and the therapeutic context is expanded to encompass thorough education on a range of treatments and the possibilities of the individual psychotherapeutic scheme.

GEOFFREY H. BLOWERS AND TERESA YUAN

### **Bibliography**

- Blowers, G.H. (2004). Bingham Dai, Adolf Storfer, and the tentative beginnings of psychoanalytic culture in China: 1935–1941. *Psychoanalysis and History*, 6 (1), 93–105.
- Gerlach, A. (1995) China. In P. Kutter (Ed.) *Psychoanalysis International: A guide to Psychoanalysis throughout the world* (Vol. 2, pp. 94–102). Stuttgart-Bad Cannstatt: Fromman-Holzboog.
- Joseph, E.D. (1987). Psychiatry and psychoanalysis in the People's Republic of China: a transcultural view. In R. Fine (Ed.), *Psychoanalysis around the world*. New York: Howarth Press.
- Yuan, T. A. (2000). China in the history of psychoanalysis: a possible fate for psychoanalysis at the dawn of the

millennium. 8th International Meeting of the International Association for the History of Psychoanalysis.

Zhang, Jingyuan. (1989). Sigmund Freud and Modern Chinese Literature. *Ph.D. dissertation*. Cornell University.

## **CHOICE OF NEUROSIS**

As soon as a unified theory of neurosis had been formulated, the factors that determined the clinical form the neurosis assumed in particular cases had to be specified. The study of the choice of neurosis was concomitant, for Freud, with the development of the general theory of psychoneuroses.

The term *neurosis*, coined in the eighteenth century by Cullen, first referred to a heterogeneous set of illnesses attributed to a crisis of nerves. During the nineteenth century, the classificatory system was revised based on individualization of illnesses as different as exophthalmic goiter (Graves' disease) and Parkinson's disease. The idea of consolidating characteristic mental disturbances (the madness of doubt and phobias) and a neurosis (hysteria) within a single framework occurred after the psychological nature of hysteria ("the great neurosis") was established at the end of the nineteenth century, by Charcot in Paris and Breuer in Vienna. Freud (Charcot's student and Breuer's collaborator) and Janet (Charcot's student) were responsible for the two principal theoretical constructions that established the unified theory of neurosis. These two constructions differed in their conceptualization of the mechanisms and causes of neurosis, and the two theories also approached the choice of neurosis very differently.

For Freud, the explanation of the choice of neurosis evolved directly from the theory of neurosis, initially described in 1896. This is expressed clearly in Freud's correspondence with Fliess (especially the letters dated January 1, May 30, and December 6, 1896) and in two articles, "Heredity and the Etiology of the Neuroses" (1896a) and "Further Remarks on the Neuro-Psychoses of Defence" (1896b), situated within the framework of the traumatic theory of neuroses: Nothing in the nature of the trauma itself enables us to differentiate the choice of neurosis; the cause must be sought for elsewhere. Initially, Freud referred to a disposition of attitude at the time of the trauma. Sexual incidents passively experienced during childhood predisposed the subject to hysteria, while those in which the child played

an active role predisposed the subject to obsessive neurosis. This theory was soon abandoned in favor of a chronological approach, and a decade later, Freud repudiated it explicitly.

Its replacement, the chronological theory, was based on the principle that the dates of childhood events play a decisive role. Initially, the date of the trauma was considered crucial. But, in a January 1897 letter to Fliess, Freud modified his position and claimed the key moment took place at the time of repression. In a letter of November of that same year, he concluded, "It is probable, then, that the choice of neurosis (the decision whether hysteria or obsessional neurosis or paranoia emerges) depends on the nature of the wave of development (that is to say, its chronological placing) which enables repression to occur—i.e. which transforms a source of internal pleasure into one of internal disgust" (1950a, p. 271).

The question was still not fully resolved, however, as Freud noted two years later in his December 9, 1899, letter to Fliess. Meanwhile, the theory of trauma had given way to the theory of libidinal development and intrapsychic conflict. Freud retained the chronological point of view, but what was important to him now was the type of relationship the relevant stage of development allowed one to establish with others: one of autoeroticism or alloeroticism (homo- or heteroeroticism). Curiously, hysteria and obsessional neurosis are lumped together, the second considered a variant of the first. What was important to him at this point was the distinction between them and paranoia, which, unlike hysteria and obsessional neurosis, originates in autoeroticism.

The approach that remained the basis for the theory of psychoanalysis and makes use of the concept of *point of fixation* can be dated to *Three Essays on the Theory of Sexuality* (1905d). In the last pages of the work, Freud discusses the role of regression, which, at the time of the conflict, leads the libido to return to an earlier stage, the choice of stage depending on an attraction factor, the tendency to fixation that characterized the earlier development of the libido. The chronological significance was no longer considered proactively (the age of the past event) but retroactively (the return to a particular position).

It is within this new conceptual framework that Freud developed the perspectives in "Formulations on the Two Principles of Mental Functioning" (1911b)

and the psychopathological study that concludes the Schreber case (1911c). Moreover, this "canonical" version was used didactically in the twenty-second chapter of the *Introductory Lectures on Psychoanalysis* (1916–1917a). On the basis of a metaphor (the migration of a people, elements of which are established at different intermediate stages) and a biological model (his own histological work on the embryology of eel gonads), he introduces the concepts of fixation and regression before emphasizing the multiple factors that go into determining a neurosis and the role of "complemental series." By insisting on the role of intrapsychic conflict, he is led to consider the role of the ego and the defense mechanisms, a consideration he had already developed in "The Disposition to Obsessional Neurosis: A Contribution to the Problem of Choice of Neurosis" (1913i).

In this last text, Freud describes the chronological factor as dependent on the development of infantile sexuality. But, while providing a now-classic description of the stages of this development, he suggests that the predisposition to the choice of neurosis has as much to do with the libidinal relationship to the object as it does to the ego defense mechanisms associated with each of the steps. He firmly maintains the chronological reference, as long as the development of the ego as well as that of the libido is taken into consideration.

This change in the Freudian outlook cannot be understood without reference to the early work of Karl Abraham. In a series of articles published between 1921 and 1925, Abraham made significant contributions to the establishment and refinement of the relation between libidinal development and nosological categories. In 1924 he published "A Short Study of the Development of the Libido, Viewed in the Light of Mental Disorders," an essay that falls well within the bounds of the Freudian perspective but goes beyond it in its description of the neuroses, proposing a chronological model that explains all aspects of mental pathology.

A few years before this, in "Stages in the Development of the Sense of Reality" (Ferenczi, 1913/1980), Ferenczi had expanded the hypothesis advanced by Freud according to which the choice of neurosis is determined by the development of the ego and the libido, specifying that development of the ego could be understood with reference to the sense of reality.

Subsequently, the term “choice of neurosis” disappeared from the vocabulary of Freud and his successors. The term itself had not been very well chosen in the sense that it was not describing choice actively made by the subject but a complex process resulting from a set of determinants. Subsequent interest turned to the comparative determination of neuroses and psychoses.

In the field of neuroses the issue then shifted from the causes determining the “choice” of neurosis (or the factors predisposing to it) to the study of structural traits that could be used to distinguish obsession from hysteria. There was less interest in symptoms than in the underlying structure. The distinction was based on a theory of the ego and libido, in keeping with the thinking that inspired it. An especially illustrative example of this type of approach is the work of Jacques Lacan and a number of his students. But these structural models tend to describe the process more than its genesis.

At the end of the twentieth century and beginning of the twenty-first, the psychoanalytic theory of neurosis and choice of neurosis were been approached from two different perspectives. The first, inspired by behaviorism, questions the principle of a neurotic structure and focuses instead on the mechanisms of conditioning that explain the production of the symptom. The second questions the unitary concept of neurosis and, within the framework of recent American nosological classifications, many clinical neuroses have lost their labels and are found scattered among heterogeneous nosological categories, implying the existence of a number of pathogenic explanations. In both cases the question of choice of neurosis never appears, at least not in the terms in which psychoanalysis has traditionally presented it. Thus the concept that had so strongly aroused Freud’s interest at the beginning of psychoanalysis seems to attract less attention from psychoanalysts a century later. The question may again become relevant if the unified concept of neurosis returns to a prominent place in nosography.

DANIEL WIDLÖCHER

See also: Constitution; Conversion; Doubt; Libidinal stage; Organic repression; Somatic compliance.

### Bibliography

Abraham, Karl. (1949). A short study of the development of the libido, viewed in the light of mental disorders. In *Selected papers of Karl Abraham, M.D.* (D. Bryan and A. Strachey, Trans.). London: Hogarth. (Original work published 1924)

Ferenczi, Sándor. (1980). Stages in the development of the sense of reality. In *First contributions to psychoanalysis*. New York: Brunner/Mazel. (Original work published 1913)

Freud, Sigmund. (1896a). Heredity and the etiology of the neuroses. *SE*, 3: 141–156.

———. (1896b). Further remarks on the neuro-psychoses of defence. *SE*, 3: 157–185.

———. (1905d). *Three essays on the theory of sexuality*. *SE*, 7: 123–243.

———. (1911b). Formulations on the two principles of mental functioning. *SE*, 12: 213–226.

———. (1911c). Psycho-analytic notes on an autobiographical account of a case of paranoia (dementia paranoides). *SE*, 12: 1–82.

———. (1913i). The disposition to obsessional neurosis: a contribution to the problem of choice of neurosis. *SE*, 12: 311–326.

———. (1916–17a [1915–17]). Introductory lectures on psycho-analysis. Parts I & II, *SE*, 15–16.

Freud, Sigmund, and Fliess, Wilhelm. (1985c [1887–1904]). *The complete letters of Sigmund Freud to Wilhelm Fliess 1887–1904* (Jeffrey Moussaieff Masson, Trans.). London: Belknap/Harvard University Press.

### CHOISY, MARYSE (1903–1979)

Journalist, writer, and founder of the review *Psyché*, Maryse Choisy was born in Saint-Jean-de-Luz on February 1, 1903, and died in Paris on March 21, 1979. She was an officer of the National Order of Merit, and was awarded a silver medal of Arts, Lettres, et Sciences, and the Lamennais Prize (1967).

She was raised in an old château in the Basque country by wealthy aunts. At the end of the First World War, she continued her studies in Cambridge, then entered Girton College and prepared her dissertation on Samkhya philosophy; she also studied yoga.

When she was twenty-four—the year was 1927—she had her first contact with psychoanalysis when she sought treatment with Sigmund Freud. At their third meeting she related an anxiety dream that Freud responded to by stating, “You are an illegitimate child.” Incredulous, she nevertheless followed his advice by asking her aunt about her birth. Her illegitimacy was confirmed. That was all she learned of her birth, but she never returned to Berggasse Street. It was another twenty years before she again had any involvement with psychoanalysis.

Through her career as a journalist and writer, she became an active participant in the intellectual life of the 1930s. She wrote some thirty books: novels, poems, essays, and personal journalism (she became a journalist with *L'Intransigent* in 1925), which brought her fame. Between 1927 and 1931 there appeared *Un mois chez les hommes* (A month among men; on the monks of Mount Athos), *Un mois chez les filles* (A month among girls; on prostitution), which caused a scandal upon its publication, *L'Amour dans les prisons* (Love in the Prisons), and *Un mois chez les députés* (A month among parliamentarians).

She criticized the Surrealist Manifesto, which she felt was based on a false understanding of Freud's concept of the unconscious, and, in *Nouvelles littéraires*, published her "Manifeste surréaliste," in 1927. She married the journalist Maxime Clouzet. In 1932 their daughter Colette was born. There followed *Neuf mois*, (Nine months), *Savoir être maman* (How to be a mama), and two books of children's stories.

In 1927 her first novel appeared, entitled *C6 H8 (Az03)6 Mon coeur dans une formule* (My heart in a formula). She felt she was expressing the aspirations of the younger generation of the time, breaking the habits of a "generation of pen pushers," "a generation that was horizontal from five to seven," she described, "in the twenties, we are a vertical brood." In 1929, following a mystical crisis, she dabbled in various forms of spiritualism until her meeting with Pierre Teilhard de Chardin in 1938, a turning point in her spiritual quest. She converted and, after the Liberation, devoted her efforts to bringing together science, religion, and psychoanalysis. She used psychoanalysis to satisfy her religious ideals, both those of Catholicism and those of a "meditative" and "orientalist" ecumenicalism, through which she affirmed her "adherence to the ideals of the Roman Catholic church."

The review *Psyché*, founded in 1946, reflects these concerns. Together with Father Leicester King of Oxford, she founded the Association Internationale de Psychothérapie et de Psychologie Catholique (International association of Catholic psychotherapy and psychology).

She resumed her analysis, this time with René Laforgue. She felt she was a victim of Freud's "savage" analysis, comparing herself to Dora, but she did not question his genius, which reminded her of Einstein. The fact that Laforgue was a dissident and had

dropped out of the International Psychoanalytic Association encouraged Choisy to begin a second, training analysis with Maurice Bouvet. She considered this an obligation but acknowledged she had made a "solid negative transference."

*Un mois chez les filles* was about prostitution but Choisy intended to approach it the same way Freud approached neurotics, restoring to them their humanity and avoiding Tolstoy's moralizing or the aestheticism of Pierre Louÿs and Francis Carco. (The book was rediscovered and published in 1961 in the United States as *Psychoanalysis of the Prostitute*.) In 1949 Choisy published a study on the "Métapsychologie du scandale" in *Psyché*, reprinted in her book *Le Scandale de l'amour* (The scandal of love). She published four other works popularizing psychoanalysis. Her last book, published in 1978, is volume two of her memoirs, significantly subtitled: *Sur le chemin de Dieu on rencontre d'abord le diable* (On the path to God we first meet the devil).

Choisy had an adventurous and provocative intellect that she developed through her many publications, and she occupied an important position in the intellectual world of pre-War Paris. But it was only after the Liberation that she became part of the history of psychoanalysis for two complementary reasons: First, her efforts to obtain official recognition of psychoanalysis by the Catholic church and encourage practitioners and researchers to consider positions that were different and sometimes radically distinct, and second, the creation of the review *Psyché*, which, more than all her other writing, constitutes her "psychoanalytic oeuvre" and explains her renown in the field.

JACQUELINE COSNIER

See also: France; *Psyché. Revue internationale de psychanalyse et des sciences de l'homme* (Psyche, an international review of psychoanalysis and human sciences).

### Bibliography

- Choisy, Maryse. (1961). *Psychoanalysis of the prostitute*. New York: Philosophical Library. (Original work published 1928)
- . (1977). *Mémoires : sur le chemin de Dieu on rencontre d'abord le Diable*. Paris: Émile Paul.
- Guillemain, Bernard. (1959). *Maryse Choisy ou l'Amoureuse Sagesse*. Paris: C.A.M.C. Hachette.

## CHRISTIANS AND JEWS: A PSYCHOANALYTICAL STUDY

Rudolf M. Loewenstein began this work in France during “the wretched year of 1941”; he finished it ten years later in the United States and dedicated it to “the Christians who sacrificed themselves to defend the persecuted Jews” (1952). Loewenstein, who would become one of the founders of ego psychology in the United States, was then director of a psychoanalytic journal financed by Marie Bonaparte, with whom he began to discuss aspects of the anti-Semitic environment in France. “We are in a revolutionary period . . .,” he wrote. “Blood has not yet been spilled. . . . But the people need to grapple with someone, they need victims. . . . Hence, the Jews.”

More personal motives also compelled Loewenstein to write *Christians and Jews*. Born in Russia, he was a citizen of several nations before, having settled in France and identified himself entirely with the French, he suddenly found himself scorned and rejected by his adopted country because he was Jewish. He believed that psychoanalysis could contribute to some better understanding of anti-Semitic attitudes and might even offer a solution.

Loewenstein began by reviewing the known causes of anti-Semitism, citing various works and historical documentation. He then offered examples from his experience as an analyst; he believed that therapy represented “a good opportunity for a kind of experimental study in the incipient and developmental stages of anti-Semitism” (p. 30). Citing Leon Pinsker, the Russian physician and author of *Auto-Emancipation* (1882 [1916]), Loewenstein discussed “judeophobia” as a type of demonophobia, a near-psychosis that incorporates feelings of fear, hatred, and disgust. Certain forms of anti-Semitism represent aspects of paranoia, such as xenophobia, revulsion over circumcision, and projection of self-hatred, while other characteristics, such as religious intolerance and economic rivalry, have an opportunistic appeal.

Loewenstein’s hypothesis, based on Gustave Le Bon’s theory of collective psychology, is that anti-Semitic tendencies, latent in individuals, suddenly metamorphose in groups into violent attitudes that spread like an epidemic. Hitler’s anti-Semitic laws and his persecution of Jews, for example, enabled latent anti-Semitism in individual Germans to manifest itself. The underlying mechanisms rely on irrational and absurd medieval beliefs, such as the putatively

peculiar anatomy of the Jew (a hidden tail, menstrual periods in males) and his supposedly demonic character (engagement in ritual murder, sexual perversions), as well as modern beliefs (Jewish culpability in starting wars, international financial cabals, Jewish-Masonic conspiracies). Loewenstein also suggested another, more oedipal level to anti-Semitism, as reflected in Freud’s *Moses and Monotheism*, viewing the struggle of the early Christians, with their hatred of the old religion, as a means of avoiding the “return of the repressed”—the recollection of their own revolt against imposed religion. Finally, Loewenstein questions whether the Jews do not themselves aid in perpetuating anti-Semitic reactions, in a chapter titled “On ‘Jewish’ Character Traits and Social Structure.”

Skeptical of Zionism as a political solution because it might provoke anti-Semitism, Loewenstein called for a pedagogical solution. He proposed teaching sacred history in a less anti-Semitic spirit and, always philosophical, he suggested a mutual search for understanding between Christians and Jews for the good of mankind.

A courageous book, *Christians and Jews*, together with works by Imre Hermann (1945) and Ernst Simmel (1946), was among the earliest psychoanalytically-informed works on the subject. It is not a landmark work, however. Loewenstein’s use of a medical model, with its description of symptoms, etiology, and finally treatment, is inadequate to understand the modern antipathy and negative attitudes toward Jews known as anti-Semitism.

MICHELLE MOREAU RICAUD

See also: Loewenstein, Rudolf M.; Racism, anti-Semitism and psychoanalysis.

### Source Citation

Loewenstein, Rudolf M. (1952). *Christians and Jews; A psychoanalytical study*. New York: International Universities Press.

### Bibliography

- Hermann, Imre. (1945). *Az antiszemizmus lélektana*. (The psychosis of anti-Semitism), Budapest: Bibliotheca.
- Pinsker, Leon. (1916). *Auto-emancipation*. New York, Federation of American Zionists. (Original work published 1882)
- Simmel, Ernst. (1946). *Anti-Semitism. A social disease*. New York: International Universities Press.

## CINEMA AND PSYCHOANALYSIS

As contemporaries, cinema and psychoanalysis both reveal, in their own way, mankind's complex personality. The interior dramas that psychoanalysis brings to light can be experienced within the "other scene" of cinematic fiction. The similarity of certain terms and the occasional apparent resemblances between the two techniques encourage spontaneous comparisons: During psychoanalysis the subject is confronted with fantasized "representations" and can identify with "projected" characters. And we often speak of "dream screens."

Psychoanalysis as perceived by the cinema, especially by Hollywood, has not escaped a degree of confusion. For, while engaging in one sense with the "question of lay analysis," American psychoanalytic practice is related to psychiatry. Therefore, in American film productions as well as in critical analyses of those films, there has not always been a clear distinction between psychiatry and psychoanalytic practice. To bring the relation into sharper focus, I will not consider films that depict the world of psychiatry, such as *Shock Corridor* (Sam Fuller, 1963), *Lilith* (R. Rossen, 1964), or *One Flew Over the Cuckoo's Nest* (Milos Forman, 1975). This article will avoid discussion of the serial killer films of the nineteen eighties (*Henry, Portrait of a Serial Killer* by J. McNaughton, 1985, released in 1990, *The Silence of the Lambs* by Jonathan Demme, 1991, *Seven* by D. Fincher, 1995, and others).

The term "psychoanalysis" appeared for the first time in Sigmund Freud's *Heredity and the Aetiology of the Neuroses* (1896). Almost simultaneously, on December 28, 1895, the Lumière brothers, inventors of the cinematograph, organized the first paid movie in Paris. The show, twenty minutes long, contained the famous *Arrivée du train en gare de La Ciotat* and *La Sortie de l'usine Lumière à Lyon*.

It took the cinema more than twenty years to present psychoanalytic imagery, even in a rudimentary form. In 1919, R. Wiene filmed *The Cabinet of Dr. Caligari*, in which a mad doctor—at least that's what he claims to be—uses hypnosis for evil purposes, just as the diabolical Dr. Mabuse in the film of the same name (Fritz Lang, 1922), released three years later, made use of his hypnotic powers for criminal purposes.

On the other hand it took psychoanalysis a number of years before it approached cinema. Münsterberg did write a 1916 essay, *Le Cinéma: étude psychologique*, but it was only in 1970 that, for the first time, film analysis

made use of the tools of psychoanalysis (*Les Cahiers du cinéma*, no. 223). The authors dissected *Young Abe Lincoln* (John Ford, 1939) and analyzed the importance of the Law (personified by Henry Fonda as Lincoln) and the Oedipus complex it implied.

The history of the relation between psychoanalysis and cinema can be subdivided into three major periods. In its earliest manifestations (*Caligari* and *Mabuse*), psychoanalysis became, during the thirties, a familiar figure to cinema, although it often assumed the form of caricatured archetypes, which revealed a complete misunderstanding of psychoanalytic reality. It was superficial and incompetent (*Carefree*, M. Sandrich, 1938, *Bringing up Baby*, Howard Hawks, 1938), disturbing and ambitious (*Mr. Deeds Goes to Town*, Frank Capra, 1936), or provided effective, although simpleminded, advice (*Blind Alley*, King Vidor, 1939). It still had little to do with the behavior of ordinary people.

After the Second World War, the references to psychoanalysis (psychiatrists treating shell-shocked soldiers, for example)—at least in terms of explanatory material—made psychoanalysis seem more serious and sympathetic. Its cinematic representation followed this positive evolution. It was the seductive Peterson (Ingrid Bergman) who enabled Ballantyne (Gregory Peck) to remember the traumatic childhood scene that, having been repressed, had led him to believe he was guilty of murder (*Spellbound*, Alfred Hitchcock, 1945). It is Moss, the G.I. in *Home of the Brave* (S. Kramer, 1949), who, returning home after the war, is healed of the paralysis that resulted from his inferiority complex. Psychoanalysis, although not yet fully understood, is here better integrated in social life and becomes a "serious" reference.

More recently we have seen a return to a more critical position. *Dressed to Kill* (Brian de Palma, 1980) involves an analyst who is a serial killer of women. The grasping psychoanalyst in *Passage à l'acte* (F. Girod, 1997), manipulated by his patient, becomes his assassin with few second thoughts. The psychoanalysts portrayed by Woody Allen are frequently among the funniest characters in his films. Psychoanalysis, neither caricature nor definitive "knowledge," becomes a subject for the cinema that can be treated objectively and even ridiculed.

Even though he allowed himself to be filmed by his close friends (Marie Bonaparte, Mark Brunswick, René Laforgue, Philip Lehrman, see Mijolla, A. de,

1994), Freud was never very interested in the cinema. Arguing that “he didn’t feel that a plastic representation of our abstractions worthy of the name could be made,” he disavowed his disciples, Karl Abraham and Hanns Sachs, for their collaboration on the script of *The Mysteries of a Soul* (G. W. Pabst, 1925). He also refused a considerable sum of money offered by Samuel Goldwyn to develop a script on “famous love affairs.” This suspicion of the filmic representation of psychoanalysis continued after the death of its founder. It was primarily Freud’s daughter who opposed any attempt to make a film about Freud. Fearing Anna Freud’s hostility, John Huston abandoned the idea of using Marilyn Monroe to play the part of Cecily in *Freud, the Secret Passion* (1962).

Should we attribute to this suspicion the paucity of films about Freud? The few films that do represent Freud show him during the early years of psychoanalysis. *The Seven-Percent Solution* (H. Ross, 1976) is a comedy in which the founder of psychoanalysis attempts to cure Sherlock Holmes of his cocaine addiction, a wink at Freud’s own experience. *Sogni d’oro* (Nino Morretti, 1981) involves the making of a film entitled “Freud’s Mother,” in which the fictional relations of Sigmund and Amalia are treated comically. In a more serious vein, *Nineteen-Nineteen* (H. Brody, 1984) evokes Freud in flashback psychoanalyzing two celebrated patients, the Wolfman and the young woman described in “a case of female homosexuality” (1920a). John Huston’s *Freud* (1962) is the only film that seriously and directly confronts the theoretical and practical questions of psychoanalysis through a “biographical” fiction.

Like Freud leaving the famous 1921 photograph—cigar in hand, without his glasses—to come to life in *Lovesick* (M. Brickman, 1983), the image of the fictional psychoanalyst is often a stereotype or caricature: white beard, tiny pince-nez glasses, maybe a strong foreign accent. He becomes the old doctor Brulov in *Spellbound* (1945) or the disturbing Caligari (1919) or Mabuse (1922), who make use of their knowledge of hypnosis for evil purposes. Nor are they the only ones. The analyst in *Nightmare Alley* (E. Gouling, 1947) makes use of his patients’ confidence to blackmail them.

Even though the psychoanalyst’s image in cinema evolves after the Second World War, becoming more reassuring, it still retains an aura of strangeness. The two doctors—even if they are not, strictly speaking, psychoanalysts—who appear in *Seventh Heaven* (B. Jacquot, 1997), are oddly different from the other

characters in the film. The first, and most important, disappears as mysteriously as he appears.

In Hollywood films classical Freudian concepts are used: the neurosis of anxiety, the Oedipus complex, the repression of an infantile trauma. In most cases, the model used, at least implicitly, is based on the *Studies on Hysteria*; the spectacular effects of the catharsis can be used for the purposes of dramatization. Bringing back a repressed memory is sufficient for healing. This occurs in *Secret Beyond the Door* (Fritz Lang, 1948), in *Suddenly, Last Summer* (Joseph L. Mankiewicz, 1959), *The Snake Pit* (Anatol Litvak, 1949), and even, although it is caricatured, in *Marnie* (Alfred Hitchcock, 1964). Dreams have obviously assumed their place as one of the *deus ex machina* of cinema, beginning with the dream sequence in *Spellbound*, designed by Salvador Dali. The analysis of a recurrent dream experienced by one of the characters is used to solve the “enigma” at the heart of the script. Nightmares occur in *Pursued* (Raoul Walsh, 1949), *Lady in the Dark* (M. Leisen, 1944), *Secret Beyond the Door* (1948), and *The Three Faces of Eve* (N. Johnson, 1957). Then there are the dreams of Freud himself, taken from the *Interpretation of Dreams* (1900a), which are used in *Freud: The Secret Passion* (1962). Unraveling these oneiric obsessions resolves the character’s neurosis and the story (the film) comes to an end.

For the purposes of dramaturgy, psychoanalysis is used by cinema to cure patients and especially to reveal the neuroses of psychoanalysts, their entourage, and society. *The Cobweb* (Vincente Minelli, 1955) is the model for this type of exposition. In the film Richard Widmark, a psychoanalyst working in an institution, is impotent with his wife, with whom he disagrees.

Should we be surprised then that Hollywood’s celluloid psychoanalysts, psychiatrists especially, rarely engage in any real psychoanalysis—often confused with hypnosis—and that the framework of the psychoanalytic cure is rarely respected? In *Spellbound*, Dr. Petersen (Ingmar Bergman) is seated next to her patient, the so-called Dr. Edwards (Gregory Peck); the psychoanalyst in *Sex and the Single Girl* (R. Quine, 1964), played by Natalie Wood, does the same and, as in so many representations, writes down his remarks. In *Lady in the Dark* (1944), the analyst’s seat is placed behind the couch but the patient is seated. This difficulty in displaying the psychoanalytic frame—the analyst lying on a couch and the psychoanalyst seated behind him in another plane—has been neatly



resolved by H. Brody in *Nineteen-Nineteen* (1984). Here, two of Freud's former patients recall their respective psychoanalysis. When the therapy is shown on screen, the psychoanalyst (Freud), is not in the picture, only his voice is present (Mijolla, A. de, 1994).

Even today it seems that cinema continues to insist that psychoanalysis is hypnosis (the dramatic effects of which are evident on screen) or catharsis (which facilitates explanatory shortcuts). Nonetheless, its representation has become more subtle and it is now fully integrated in the film. In *Seventh Heaven*, psychoanalysis is not only part of the script but present on screen as well. White surfaces are used by the heroine to project her traumatic memories. Similarly, F. Girod makes psychoanalysis the background for *Passage à l'acte* (1997). Psychoanalysis is given the comic treatment in nearly all of Woody Allen's films as well as a few others (*A Couch in New York* by Chantal Ackerman, 1997). Sometimes the approach is tragicomic, as in *Another Woman* (Allen, 1988), where a woman begins to question her entire life after eavesdropping on a psychoanalyst at work through a vent in her apartment.

However, there is no need to see an analyst at work or present a formal psychoanalytic situation for psychoanalysis to be presented on screen. A number of films promote a latent psychoanalytic statement without being explicit. This is the case, for example, with the melodramas of Douglas Sirk, who presents neurotic characters (*Written on the Wind*, 1956), with many of Ingmar Bergman's films (*The Silence*, 1963, *Persona*, 1966, *Cries and Whispers*, 1973, *Autumn Sonata*, 1978), with Michael Powell's *Peeping Tom* (1960), and any of Tex Avery's productions, which use comedy to present neurosis.

It is often in films where the elements of psychoanalysis are presented but not spelled out that psychoanalytic concepts appear with the greatest subtlety and relevance. What would *Un chien andalou* (Luis Buñuel, 1928), that sprawling ninety-minute dream, have been like if the script had provided a psychoanalytic explanation? Probably a poor film, slow and overbearing.

It was only natural that psychoanalysis should take an interest in film, one of many cultural constructs, as Freud did, for example, with drama, beginning with *Hamlet*. Nonetheless, the theory of cinema did not make use of the tools of psychoanalysis until the early seventies. With reference to the work of Lacan, Christian Metz provided a careful spectatorial analysis, trying to determine "what contribution Freudian psychoanalysis could... provide

in the study of the imaginary signifier." Other authors also became interested in the analogy between psychoanalysis and cinema: the importance of sight (Jean-Louis Baudry), the different meanings of the word "screen" (G. Rosolata), the place of the spectator in *Persona* (N. Brown), fetishism and film noir (M. Ernet).

However, theory shouldn't cause us to overlook the many studies of individual films and directors. Raymond Bellour (1975) provided a psychoanalytic analysis (the murder of the father, the castrating mother) of Hitchcock's *North by Northwest* (1959), a film said to be frivolous and entertaining. Minutely dissecting the sequence of the airplane attack, he reveals the importance of sight and its role in the film. Similarly, T. Kuntzel (1975) made use of the Freudian discovery of the presence of the unconscious in dreams to analyze *The Most Dangerous Game* (E. B. Shoedsack and I. Pichel, 1932). Patrick Lacoste (1990) examines *The Mysteries of a Soul* (1925) from a strictly psychoanalytical point of view and Sophie de Mijolla-Mellor (1994) analyzes the way the "anxiety of fiction" operates on the spectator of Hitchcock's films.

Throughout the nineteen-eighties American film theory looked at a number of films made between 1945 and 1960 from the point of view of psychoanalysis and feminism. In several analyses that could be described as "feminist psychoanalysis," Laura Mulvey, Janet Walker, and M. A. Doane attempted to show how the role of women in cinema reflected their role in society. The approach taken by E. Ann Kaplan, which was part of this movement—one that was more sociological than psychoanalytical—emphasized issues of race in society, which the cinema reflected.

But making use of psychoanalytic concepts to examine films from a sociological perspective (feminist or antiracist) was bound to be unsatisfactory as long as these readings involved distortion and reduction; the film and its analysis became a pretext to defend, and in a way that was not always rigorous, questionable intellectual ideas. Psychoanalysis is often a pretext in the service of a discourse; once abandoned, it is seen to be an element inessential to the logical structure of the argument. Isn't this the reproach made to cinema whenever it represents psychoanalysis, a filmic representation that is generally incomplete and often a form of caricature?

If film often "fails at" representation of the psychoanalytic situation, it is no doubt because "the uncon-

scious, like the being of philosophers, rarely makes itself visible” (J.-B. Pontalis). Moreover, “the rhythm of analysis is very different from that of film, and it is quite difficult to provide an accurate representation of the sensation” (Mijolla, 1994).

A film cannot be judged on the accuracy of its portrayal of psychoanalytic notions—within certain limits, of course—but on the relevance of the use of those notions for the dramatic presentation of its themes. “From this point of view—[the use of language and the language of images as fundamental Freudian reference points] between psychoanalysis and cinema—is formed a variant of the situation of the analyst as always being between two languages” (Lacoste, 1990).

More work needs to be done on the complex relationships that are created between psychoanalysis and cinema, beyond the application of psychoanalytic concepts to the art of film.

PIERRE-JEAN BOUYER AND SYLVAIN BOUYER

See also: *American Imago*; Cinema (criticism); France; Freud, the Secret Passion; *Secrets of a Soul*; *Psyche*, revue internationale de psychanalyse et des sciences de l’homme (Psyche, an international review of psychoanalysis and human sciences); Robertson, James; Surrealism and psychoanalysis.

### Bibliography

Bellour, Raymond. (1979). *The analysis of film* (Constance Penley, Ed.). Bloomington: Indiana University Press, 2000.

*Communications*. (1975). “Psychanalyse et cinéma.” 23.

Lacoste, Patrick. (1990). *L’etrange cas du Pr. M. Psychanalyse à l’écran*. Paris: Gallimard.

Metz, Christian. (1979). *The imaginary signifier: Psychoanalysis and the cinema* (C. Britton et al., Trans.). Bloomington: Indiana University Press.

Mijolla, Alain de. (1999). Freud and the psychoanalytic situation on the screen. In J. Bergstrom (Ed.), *Endless night. Cinema and psychoanalysis: Parallel histories* (p. 188–199). Los Angeles and London: University of California Press. (Original work published 1994)

### Further Reading

Gabbard, Glen. (2001). The impact of psychoanalysis on the American cinema. *Annual of Psychoanalysis*, 29, 237–246.

Gabbard, Erin and Gabbard, Glen. (1989). *Psychiatry and the cinema*. Chicago: University of Chicago Press.

Greenberg, Harvey R. (1993). *Screen memories: Hollywood cinema on the psychoanalytic couch*. New York: Columbia University Press.

## CINEMA CRITICISM

The discipline of psychoanalysis and the art of the cinema evolved in parallel at the beginning of the twentieth century. Psychoanalysts soon began interpreting the appeal and meaning of movies. As early as 1916 Hugo Münsterberg wrote *The Film: A Psychological Study*, in which he suggested that film transforms the external world into the mechanisms of the mind, including memory, imagination, attention, and emotion.

Although Freud himself had little interest in the cinema, one of his disciples, Hanns Sachs, served as a consultant to George Wilhelm Pabst’s 1926 classic, *Secrets of a Soul*. This German expressionist film was the first serious treatment of psychoanalysis in film history, complete with rather sophisticated use of dream symbolism.

Since these early interdisciplinary efforts, a whole field of psychoanalytic film criticism has evolved. Systematic studies of movies first appeared in the 1950s in the French periodical, *Cahiers du Cinéma*. The *Cahiers* theorists subsequently appropriated Italian semiotics as well as the ideas of the deconstructionist Jacques Derrida and the French psychoanalyst Jacques Lacan. Film scholars influenced by Lacan and Derrida focus on the “deep structures” at work in movies and how meaning is generated in film. Lacan’s most important student in the field of film theory has been Christian Metz, whose work has become standard reading in academic cinema studies programs.

The Lacanian approach to film criticism centers on how audiences experience movies. The camera creates a “gaze” or perspective on the events of the film’s narrative. A key aspect of the Lacanian discourse is the concept of “lack,” both as the phallogocentric key to sexual difference and in the symbolic sense of viewing external reality in terms of absence and presence. These ideas have been appropriated by feminist semioticians like Laura Mulvey, who suggested that the woman’s body is fetishized because it creates anxiety in men, to whom it represents “lack,” i.e., castration. Moreover, the cinema is viewed as historically serving the interests of patriarchy, privileging the gaze of the male hero, while subordinating the female characters as the *object* of the gaze.

Interpretations of film based on Lacanian ideas have generated a good deal of criticism. Many have objected to the semioticians' methodology as top-heavy with theoretical formulations and too dismissive of the actual content of a film. In addition, a number of critics have pointed out that masculinity is regularly undermined in films and that male viewers often will identify with a female character. Moreover, male bodies are often fetishized in the cinema to the same extent as the female body.

Psychoanalytic film scholars have taken a number of different approaches that part ways with the Lacanian perspective. Bruce Kavin, Marsha Kinder, and Robert Eberwein, for example, have examined films from the perspective of Freudian dreamwork. Robert B. Ray and Krin and Glen Gabbard have taken a pluralistic approach to psychoanalytic film criticism, suggesting that Lacanian interpretations are reductionist and limiting, and that broadening one's theoretical perspective may be more useful when studying film.

GLEN O. GABBARD

*See also:* Cinema and psychoanalysis; Mannoni, Dominique-Octave; *Psyché, revue internationale de psychanalyse et sciences de l'homme* (Psyche, an international review of psychoanalysis and human sciences).

### Bibliography

- Gabbard, Krin, and Gabbard, Glen O. (1987). *Psychiatry and the cinema*. Chicago: University of Chicago Press.
- Metz, Christian. (1982). *The imaginary signifier. Psychoanalysis and the cinema*. Bloomington: Indiana University Press.
- Mulvey, Laura. (1977). Visual pleasure and narrative cinema. In K. Kay, G. Peary (Eds.), *Women and the cinema* (pp. 412–428). New York: Dutton.
- Ray, Robert B. (1985). *A certain tendency of the hollywood cinema, 1930–1980*. Princeton: Princeton University Press.

## CIVILIZATION AND ITS DISCONTENTS

Between 1928 and 1930, Freud devoted himself exclusively to *Civilization and its Discontents*—apart from a handful of prefaces and his acceptance speech for the Goethe prize. Dated 1930, the book appeared in December 1929. It was an immediate success, selling twelve thousand copies the first year, with the first German reprint in 1931. The book has remained

successful over the years, generating a vast amount of commentary. There were translations into English (1930), Spanish (1936), French (1943), Italian (1971), and Portuguese (1974). Freud himself was less expansive about it: during the composition of the text, Freud's cancer was painful and required care, and Max Schur became his personal physician in the spring of 1929. The first version of *Civilization and its Discontents* was written quickly, in July 1929. Freud wrote to Lou Andreas-Salomé on July 28, 1929: "Today I wrote the final sentence, the one that concludes the book. . . . It's about culture, feelings of guilt, happiness and other elevated subjects and, it rightly seems to me, quite superfluous, unlike the earlier work, behind which there was always some internal drive. But what is there to do? One can't smoke and play cards all day long. . . . During the writing, I rediscovered the most banal truths" (1966a [1912–1936]).

Freud began with Romain Rolland's criticisms of *The Future of an Illusion* (1927c) concerning the "religious sensation" and the "simple and direct fact of the 'eternal' sensation (which may indeed not be eternal, but simply without any perceptible limits, and oceanic)" (letter to Freud, December 27, 1927). He replied to Rolland on July 14, 1929, indicating that his remarks left him little rest.

Chapter one opens with a mention of the great man (Rolland) and explains the "oceanic" feeling through the concept of narcissism. Freud then develops the extensive metaphor comparing the unconscious to the archaeologist's Rome, which, like the initial ego, supposedly contains everything. It makes evident the preservation of memory traces, as if the various stages of the city since its foundation could exist simultaneously (as in the stratified spaces and multidimensional time of mathematics). Freud concluded that the oceanic feeling may exist as a memory trace, but stated that he would not pursue the investigation of the Mothers, which he mentions without elaborating. Instead, he maintains the supremacy of the religion of the Father. Like *Group Psychology and the Analysis of the Ego* (1921c), *Civilization and its Discontents* begins by circling around psychical questions, and claiming that culture is born from the religion of the Father, characteristic of European monotheistic religions.

For several chapters Freud provides a fairly commonplace description of our relation to culture. Citing a number of European writers, Freud describes the impossibility of achieving happiness, the "essence of

culture,” the ambivalent relationships we entertain with it, and the opposition between culture and sexuality. For someone familiar with Freud’s work, there is little to learn. But, using a frequent tactic, he outlines a broader scope of understanding before advancing his more incisive hypotheses, which are sketched in terms of the economic, dynamic, and topographical points of view.

It is as if Freud were asking why the forms and dynamics of groups that he constructed in *Group Psychology* were necessary, considering the inhibitions of sexual drives, the alienation that accompanies identification with large groups and the submission it entails. The response was economic: mankind’s aggressive drives endanger culture. Freud then inserts the economic hypothesis into mental dynamics. Recalling the theory of drives, he suggests that the development of culture illustrates the struggle between Eros and death, the life instinct against the destructive instinct, as it unfolds within the human species. Once the dynamic relation has been established, there remains the problem of identifying mental formations, the correlative topography. The end of the book is devoted to a subtle study of the superego, the moral conscience, remorse, guilt, and the need for punishment. “I suspect that the reader has the impression that our discussions on the sense of guilt disrupt the framework of this essay... This may have spoilt the structure of my paper; but it corresponds faithfully to my intention to represent the sense of guilt as the most important problem in the development of civilization and to show that the price we pay for our advance in civilization is a loss of happiness through the heightening of the sense of guilt” (p. 134).

Freud’s principal thesis is that the culture of patriarchal religion creates a particular way of working for the superego, which turns its aggression against the ego and expresses itself in the feeling of guilt. This process is unregulated. Once it is triggered, it worsens and becomes aggravated, exhausting not only the aggressive drives but the sexual drives as well. Moreover, “since civilization obeys an internal erotic impulsion which causes human beings to unite in a closely-knit group, it can only achieve this aim through an ever-increasing reinforcement of the sense of guilt” (p. 133). Eros itself serves the death drives or aggressive instincts, which culture serves as well. This results in the death-driven and unregulated dynamic of the cultural process.

Freud details the ontogenesis of the moral conscience and superego from the primitive social anxiety of the child—loss of the parents’ love—to the erection of an internal authority, which does not distinguish between acts and intentions and whose power is reinforced with every rejection of a drive and every real misfortune. He then claims that the origin of the feeling of guilt is the murder of the primal father, who alone is capable of provoking the conflict of ambivalence and generating the superego.

In the last chapter Freud returns to the relations between the various terms discussed, while expanding the analogy between the origin of culture and individual development. He returns to the notion of the great man, who is likely to contribute to the development of the superego in a given cultural moment. Noting that psychic processes are sometimes more accessible in the group than the individual, Freud introduces the idea of analyzing the pathology in specific of cultural communities.

Just as *Group Psychology* analyzed the ego, *Civilization and its Discontents* examines the superego, as distinct from the ego ideal. In both texts, aggression and reality are integrated in a dynamic which links individual and collective psychology. To do this Freud simplified, identifying the death drive with the urge to destruction, and culture with Eros (“civilization is a process in the service of Eros, whose purpose is to combine single human individuals, and after that families, then races, peoples and nations, into one great unity, the unity of mankind” (p. 122). This is the text in which Freud best defends and illustrates the analogy, even the identity, between individual and cultural development—the family always serving as the medium of change.

MICHÈLE PORTE

### Source Citation

Freud, Sigmund. (1930a [1929]). *Das Unbehagen in der Kultur*. Leipzig-Vienna-Zurich, Internationaler Psychoanalytischer Verlag; GW, XIV, p. 419–506; Civilization and its discontents. *SE*, 21: 57–145.

### Bibliography

- (1998). *Autour du “Malaise dans la culture” de Freud*. Paris: Presses Universitaires de France.
- Enriquez, Eugène. (1983). *De la horde à l'état*. Paris: Gallimard.
- Freud, Sigmund, and Andreas-Salomé, Lou. (1966a [1912–1936]). *Sigmund Freud and Lou Andreas-Salomé: Letters*.

(William and Elaine Robson-Scott, Trans.). London: Hogarth Press and the Institute of Psycho-Analysis.

Marcuse, Herbert. (1955). *Eros and civilization*. Boston: Beacon Press.

Vermorel, Henri, and Vermorel, Madeleine. (1993). *Sigmund Freud et Romain Rolland : correspondance 1923–1936*. Paris: Presses Universitaires de France.

## CIVILIZATION (*KULTUR*)

In *Civilization and Its Discontents*, Sigmund Freud defines civilization as follows: “The word ‘civilization’ [*Kultur*] describes the whole sum of the achievements and regulations which distinguish our lives from those of our animal ancestors and which serve two purposes—namely to protect men against nature and to adjust their mutual relations” (1930a, p. 89). In *The Future of an Illusion* Freud provided a more extended definition of civilization: “Human civilization, by which I mean all those respects in which human life has raised itself above its animal status and differs from the life of the beasts—and I scorn to distinguish between culture and civilization—presents, as we know, two aspects to the observer. It includes, on the one hand, all the knowledge and capacity that men have acquired in order to control the forces of nature and extract its wealth for the satisfaction of human needs and, on the other hand, all the regulations necessary in order to adjust the relations of men to one another and especially the distribution of the available wealth” (1927c, p. 5–6).

These definitions, however, leave out many aspects of the concept of civilization that Freud had mentioned in other works, including “Civilized Sexual Morality and Modern Nervous Illness” (1908d). These themes include the relationship of civilization to the superego and to sublimation, its consequences for neurosis, the origin of civilization, and the different attitudes of individuals toward civilization, especially as a function of their sex.

Freud’s conflation of civilization and culture here is surprising, especially when we consider that the distinction is clearly present when he discusses the force deployed by civilization (*Kultur*), on the one hand, and the “spiritual heritage of culture” used to “reconcile mankind” with that civilization, on the other, namely, the “spiritual heritage of culture” (1927c). Le Rider (1993) has pointed out that this opposition between culture and civilization had behind it a

philosophical tradition of which Freud was a part. Immanuel Kant (1724–1804) saw civilization as a ceremonial aspect of culture, and saw culture as achieved by means of a sustained effort (*Bildung*) and as culminating in the great achievements of art and thought. In a more radical perspective, Friedrich Nietzsche (1844–1900) saw civilization as subjugation and saw culture, in contrast, as the artistic and intellectual flowering of intact natures. The period between 1920 and 1939 saw the rise and spread of the idea of popular culture and the notion that culture is a means of fulfilling human life (Le Rider, 1993).

It is also arguable that Freud rejected this tradition and deliberately ignored the distinction between culture and civilization because of his theory of the birth of civilization and its link with sexuality. His theory might be considered an example of the cunning of civilization, in the dialectical sense in which G. W. F. Hegel (1770–1831) speaks of the “cunning of Reason” (Mijolla-Mellor, 1992). The cunning lies in the fact that humanity creates civilization by transforming and sublimating individuals’ instinctual aims and objects and sublimation simultaneously enables individuals to realize those aims and attain those objects in another form. Yet in doing this, humanity consolidates a cultural edifice that weighs upon individuals and imposes restrictions on them by dint of suppression. “There will be brought home to you with irresistible forces the many developments, repressions, sublimations, and reaction-formations by means of which a child with a quite other innate endowment grows into what we call a normal man, the bearer, and in part the victim, of the civilization that has been so painfully acquired” (Freud, 1910a, p. 36). Freud thus found himself once more in thrall to his concept of sublimation, whose shortcomings led him to confuse the coercion of institutionalized education with the process of individual learning (*Bildung*), a creative force and source of pleasure (intellectual pleasure) for the subject. The dialectic in which the sublimation of one group can become the source of suppression for another group that does not participate in the process of self-education without doubt constitutes a cunning of civilization, whereby a devitalized culture dons the mantle of civilizing norms.

Civilization appears as an entity in and of itself, a given for the subject on whom it is imposed: “The development of civilization appears to us as a peculiar process which mankind undergoes, and in which

several things strike us as familiar. We may characterize this process with reference to the changes which it brings about in the familiar instinctual dispositions of human beings, to satisfy which is, after all, the economic task of our lives" (Freud, 1930a, p. 96).

As Freud pointed out in "Civilized Sexual Morality and Modern Nervous Illness" (1908d), civilization, by imposing sexual frustration, has a direct effect on the genesis of neuroses. Freud repeatedly claimed that sublimation should not be a norm, since it is possible only for some people: "Mastering it by sublimation, by deflecting the sexual instinctual forces away from their sexual aim to higher cultural aims, can be achieved by a minority and then only intermittently, and least easily during the period of ardent and vigorous youth" (1908d, p. 192). For the others, submission, especially to sexual morality, has negative consequences ranging from neurosis to a degradation of sexual objects (1908d). Of those who sublimate, some are heroes, like Prometheus, whom Freud analyzes in "The Acquisition and Control of Fire" (1932a), or Hercules, about whom he writes, "The prevention of erotic satisfaction calls up a piece of aggressiveness against the person who has interfered with the satisfaction, and that this aggressiveness has itself to be suppressed in turn. But if this is so, it is after all only the aggressiveness which is transformed into a sense of guilt, by being suppressed and made over to the superego" (1930a, p. 138).

The process of civilizing is divided among ideals: coercion from the superego, cultural creation, and the resulting admiration from the ego ideal. "The satisfaction which the ideal offers to the participants in the culture is thus of a narcissistic nature; it rests on their pride in what has already been successfully achieved" (Freud, 1927c, p. 13). Here too the civilizing process reveals its unstable nature, for by reinforcing nationalism, the "narcissism of minor differences," and the cultural ideals of a people, it can become a pretext for a return to the most savage form of struggle: war.

Civilization appears as a separate entity, albeit one produced by humankind. It is necessary, though it is always excessive in its demands and premature in its anticipation: "It is an ineradicable and innate defect of our and every other civilization, that it imposes on children, who are driven by instinct and weak in intellect, decisions which only the mature intelligence of adults can vindicate" (Freud, 1927c, p. 51–52).

Alongside the writings in which Freud directly addresses the question of civilization, there are a number of anthropological texts in which, starting from the primitive horde and the murder of the father, he retraces the genesis of the matriarchy, the band of brothers, and the return to patriarchy. Yet these two perspectives are relatively dissociated in Freud's work to the extent that his ideas on civilization, with a few digressions to discuss ancient Rome or Louis XIV, the Sun King, in France, are for the most part related to the twentieth century. Abram Kardiner (1977) and Ruth Benedict (1935), writers on culture and psychoanalysis, would later make use of Freud's interest in anthropology.

Freud's views on the genesis of matriarchy, however, are totally dissociated from his writings about women. Women, Freud wrote, "come into opposition to civilization and display their retarding and restraining influence" (1930a, p. 103). Here too the cunning of civilization is on display: Women form the basis of civilization, "represent[ing] the interests of the family and sexual life." They are betrayed, however, by the fact that men sublimate to their detriment. "The woman," Freud concludes, "finds herself forced into the background by the claims of civilization, and she adopts a hostile attitude toward it" (1930a, p. 104).

SOPHIE DE MIJOLLA-MELLOR

*See also:* *Anti-Oedipus: Capitalism and Schizophrenia*; Applied psychoanalysis and the interactions of psychoanalysis; *Civilization and its Discontents*; "Claims of Psychoanalysis to Scientific Interest"; Cultural transmission; Darwin, Darwinism, and psychoanalysis; *Future of an Illusion*, *The*; Incest; Law and psychoanalysis; Marxism and psychoanalysis; *Moses and Monotheism*; Organic repression; *Phylogenetic Fantasy, A: Overview of the Transference Neuroses*; Politics and psychoanalysis; Primitive horde; Religion and psychoanalysis; Rolland, Romain Edme Paul-Emile; Smell, sense of; Sociology and psychoanalysis, sociopsychanalysis; Sublimation; Superego; Transgression; "Thoughts for the Times on War and Death."

### **Bibliography**

- Benedict, Ruth. (1935). *Patterns of culture*. London: Routledge.
- Freud, Sigmund. (1908d). Civilized sexual morality and modern nervous illness. *SE*, 9: 181–204.
- . (1910a). Five lectures on psycho-analysis. *SE*, 11: 7–55.

- . (1927c). The future of an illusion. *SE*, 21: 5–56.
- . (1930a). Civilization and its discontents. *SE*, 21: 64–145.
- . (1932a). The acquisition and control of fire. *SE*, 22: 183–193.
- Kardiner, Abram. (1977). *My analysis with Freud. Reminiscences*. New York: W. W. Norton.
- Le Rider, Jacques. (1993). Kultur contre civilisation. *Topique*, 52, 273–287.
- Mijolla-Mellor, Sophie de. (1992). *Le plaisir de pensée*. Paris: Presses Universitaires de France.

---

## “CLAIMS OF PSYCHOANALYSIS TO SCIENTIFIC INTEREST”

*The Claims of Psychoanalysis to Scientific Interest* was first published in the Italian review *Scientia*. It was the first of Freud’s texts to be translated into French, and this translation was by M.W. Horn. *Scientia*’s title page contained some information concerning the publication: it was a bimonthly based in Milan, its subtitle being *International Review of Scientific Synthesis*. It was co-edited in London and Leipzig, and in Paris by Félix Alcan. Among its contributors between 1912 and 1914 were Alfred Adler, Émile Durckheim, Albert Einstein, Henri Piéron, Henri Poincaré, and Bertrand Russell.

“I have just had to do an unwanted job, a kind of introduction to psycho-analysis for *Scientia*; I did it, not wishing to refuse in view of the admirable character of that international journal,” Freud wrote to Oskar Pfister on March 11, 1913. It was in fact a “propaganda article,” in Freud’s words to Karl Abraham on September 21, aimed at making a large public more familiar with the advantages and possibilities that psychoanalysis offered to contemporary culture. Presented in German in the review and simultaneously in French in an attached fascicule containing other translations from this resolutely eclectic collection, the first part, *Its Interest for Psychology*, was thus published in the supplement to volume XIV dated September 1, 1913. The second, *Its Interest for the Non-Psychological Sciences*, was published in the supplement to the next issue, dated November 1, 1913. For unknown reasons, although World War I no doubt had a large role to play, it remained totally unknown to French psychoanalysts until 1976.

The first part is a summary, such as Freud was good at producing, of the psychoanalytic theory of

parapraxes, dreams and their interpretation, and of the hopes of curing psychopathological affections. But the second part is perhaps the most original because in it Freud develops the spirit of “conquest” (he used the expression in a letter to Jung in 1909) with regard to “other domains of knowledge,” a spirit that motivated him ever since the afflux of students put an end to his splendid isolation. The break with the Jungians further reinforced the necessity of familiarizing researchers with the “reveals unexpected relations” (p. 165) between their subjects and the pathology of mental life” (p. 165).

First mentioned were the “language sciences,” a pre-eminence that may easily seem prophetic. Interpretation is the “translations from an alien method of expression into the one which is familiar to us” (p. 176) and the study of dream symbols evokes “the earliest phases of linguistic development and conceptual construction” (p. 176). “The language of dreams may be looked upon as the method by which unconscious mental activity expresses itself. But the unconscious speaks more than one dialect” (p. 177).

“The philosophical interest of psycho-analysis” (p. 178) comes next, specifically asserting the existence of an Unconscious that is no longer a mystical hypothesis, and the new implications of this for “the relation of mind to body” (p. 178). But Freud’s distrust of philosophers found expression in the paragraph where he extols the merits of a psychoanalytic pathography that “psychography” (p. 179) that “can indicate the subjective and individual motives behind philosophical theories which have ostensibly sprung from impartial logical work” (p. 179).

It was in terms of its “biological” (p. 179) interest that psychoanalysis attracted the most criticism: the revelation of the importance of the sexual function shocked, mainly because of the light it shed on the forbidden territory of infantile sexuality. It was, however, desirable to establish a junction between the two sciences in order to have a better understanding of the instincts, a point of contact with biology” (p. 182) and to shed light on their “active” and “passive” properties in their relations with masculinity and femininity.

“The interest of psycho-analysis from a developmental point of view” followed next, organized around the evolution from the psychic life of the child to that of the adult and the discovery that “in spite of all the later development that occurs in the adult, none

of the infantile formations perish. All the wishes, instinctual impulses, modes of reaction and attitudes of childhood are still demonstrably present in maturity and in appropriate circumstances emerge once more” (p. 184). Moreover, psychoanalysis confirmed the idea that “ontogeny is a repetition of phylogeny” (p. 184), which demonstrated its “interest . . . from the point of view of the history of civilization” (p. 184) in relation to deciphering myths, understanding primitive peoples, ancient civilizations and religions. The new hypothesis was that “the principle function of the mental mechanism is to relieve the individual from the tensions created in him by his needs. One part of this task can be achieved by extracting satisfaction from the external world; and for this purpose it is essential to have control over the real world” (p. 186). The study of the neuroses demonstrated the same dynamism and thus enriched anthropological research with its discoveries.

“The interest of psycho-analysis from the point of view of the science of aesthetics” (p. 187) is next stressed, opening the door to this form of “applied psychoanalysis” that has been of such importance in the history of psychoanalysis. But Freud cautiously states that “the motive forces of artists are the same conflicts which drive other people into neurosis and have encouraged society to construct its institutions. Whence it is that the artist derives his creative capacity is not a question for psychology” (p. 187). Art “constitutes a region half-way between a reality which frustrates wishes and the wish-fulfilling world of the imagination—a region in which, as it were, primitive man’s strivings for omnipotence are still in full force” (p. 188).

The erotism underlying social relations and the repression required by the cohabitation of human beings are essential psychoanalytic contributions to “sociology.” Hence, also, “the educational interest” (p. 189) of a science that becomes more familiar with the real psychic life of the child and its evolution. “We grown-up people cannot understand children because we no longer understand our own childhood” (p. 189). Teachers learned from the discoveries concerning the “Oedipus complex, self-love (or ‘narcissism’), the disposition to perversions, anal erotism, [and] sexual curiosity” (p. 189). Psychoanalysis “can also show what precious contributions to the formation of character are made by these asocial and perverse instincts in the child, if they are not subjected to repression but are diverted from their original aims

to more valuable ones by the process known as ‘sublimation.’ Our highest virtues have grown up, as reaction formations and sublimations, out of our worst dispositions” (p. 190).

ALAIN DE MIJOLLA

*See also:* Anthropology and psychoanalysis; Applied psychoanalysis and the interactions of psychoanalysis; Ego; France; *Imago. Zeitschrift für die Anwendung der Psychoanalyse auf die Geisteswissenschaften*. “On the History of the Psychoanalytic Movement”; Psychoanalytic epistemology; Sociology and psychoanalysis, sociology.

#### Source Citation

Freud, Sigmund. (1913j). Das Interesse an der Psychoanalyse. *Scientia*, XIV, p. 240–250, 369–384; *GW*, VIII: 389–420; The claims of psycho-analysis to scientific interest. *SE*, 13: 163–190.

### CLAPARÈDE, ÉDOUARD (1873–1940)

Édouard Claparède, a Swiss physician and psychologist, was born March 24, 1873, in Geneva, where he died September 30, 1940. He was born into a Protestant family that left Languedoc after the revocation of the Edict of Nantes; his father was a pastor. His precocious interest in natural science, the legacy of his childhood admiration for the paternal uncle whose name he bore, would have repercussions on his future career. Claparède did not feel any religious calling and envisaged a future in the sciences. The individual who had the greatest influence on him was his uncle Théodore Flournoy, nineteen years his senior. It was because of him that Claparède developed an interest in psychology. This interest led him to study medicine, which seemed to him “the best introduction to the study of mankind.” He completed his medical studies in Geneva in 1897 after a brief period of study in Leipzig. In 1899 he became a collaborator with Flournoy, who turned over to him the job of running the psychology laboratory in 1904.

Together with his uncle, Claparède founded the *Archives de psychologie* in 1901, where the first French reviews of Freud’s work appeared, together with that of other psychoanalysts. In 1903 they published Théodore Flournoy’s review of *The Interpretation of Dreams*. There were several articles on Freud’s work,



including *Über Psychotherapie* (“On Psychotherapy”; 1905) and another on *Zur Psychopathologie des Alltagslebens* (*The Psychopathology of Everyday Life*; 1905). It was not long before discussions were underway to make the *Archives de psychologie* a French-language “psychoanalytic journal.” This effort, undertaken by Carl Gustav Jung, was unsuccessful. But the review did publish work by Jung, Alphons Maeder, Charles Baudouin, Charles Odier, Henri Flournoy, and Raymond de Saussure. Every year critical essays on psychoanalytic works appeared, but the psychoanalysis section disappeared from the review in 1930.

In 1912 Claparède founded the Institut Jean-Jacques Rousseau, where the psychoanalysts Ernst Schneider (1916–1919) and Charles Baudouin began teaching in 1915. When Sabina Spielrein came to Geneva in 1920, she became his assistant. Oskar Pfister dreamed that the institute would become a place where “teaching psychoanalysts” would be trained. But his project never materialized.

Claparède was responsible for the first French translation of Freud’s *Über Psychoanalyse, Fünf Vorlesungen gehalten zur 20 jährigen Gründungsfeier der Clark University* (*Five Lectures on Psychoanalysis*). The translation was published in the December 1920 and January and February 1921 issues of the *Revue de Genève*, with the title “Origine et développement de la psychanalyse.” The translator was Yves Le Lay. Claparède added an introduction entitled “Freud et la psychanalyse.”

Claparède took part in the Salzburg (1908) and Nuremberg (1910) Congresses. He founded the Cercle Psychanalytique de Genève (Geneva Psychoanalytic Circle) in 1919, of which he became president, but he did not belong to the Société Suisse de Psychanalyse (Swiss Society for Psychoanalysis), created on February 10, 1919. On September 19, 1919, he was invited to join. His correspondence with Freud was published by Carlo Trombetta (1970). He also corresponded with Oskar Pfister.

It can be assumed that Claparède underwent a certain amount of psychoanalysis with Pfister between 1915 and 1918. Was he analyzed by Sabina Spielrein during the twenties? We have no confirmation of this and if he did undergo analysis, it would only have been for a short period of time. Freud spoke of him as a dilettante. An eclectic individual, Claparède never wanted to become too deeply involved in psychoanalysis.

Aside from his essays in *Archives de psychologie*, Claparède published “Quelques mots sur la définition de l’hystérie” (1907), “De la représentation des personnes inconnues et des lapsus *linguae*” (1914), “Freud et la psychanalyse” (1920), “Quelques remarques sur le subconscient” (1923), “Freud va avoir quatre-vingt ans” (1936).

Claparède was not, strictly speaking, a psychoanalyst but he favored the diffusion of psychoanalysis in French-speaking Switzerland and, therefore, in France, and he defended psychoanalysis against its detractors. As Freud wrote to him on May 24, 1908, concerning psychoanalysis: Claparède is “in some sense a measure of the international growth to which we aspire.”

MIREILLE CIFALI

*See also:* *Archives de psychologie, Les*; Institut Claparède; Société psychanalytique de Genève; Subconscient; Switzerland (French-speaking).

### Bibliography

- Cifali, Mireille. (1982). “Entre Genève et Paris: Vienne,” *Bloc-notes de la psychanalyse*, 2, 91–127.
- . (1991). Notes autour de la première traduction française d’une œuvre de Sigmund Freud. *Revue internationale d’histoire de la psychanalyse*, 4, 291–305.
- Claparède, Edouard. (1920). Freud et la psychanalyse. *Revue de Genève*, 6, 850–851.
- Trombetta, Carlo. (1970). “Claparède e Freud. Con pubblicazione di inediti,” *Orientamenti pedagogici*, 17, 6.
- . (1989). *Édouard Claparède psicologo*. Rome: Armando. Clark University

---

## CLARK UNIVERSITY

Sigmund Freud’s only visit to the United States was in 1909, when he was invited by G. Stanley Hall, first president of Clark University in Worcester, Massachusetts, to deliver a series of lectures to celebrate the twentieth anniversary of the university.

Hall invited twenty-seven other distinguished participants, all of whom received honorary degrees, including the Nobel Laureates in physics Albert Michelson and Ernest Rutherford. But clearly Freud was the most important participant, in Hall’s view; part of the celebration was delayed from July to September, the date Freud requested, so as not to interfere with his private practice. Hall also invited Carl Gustav

Jung to participate, and Freud asked Sándor Ferenczi to accompany him. The three psychoanalysts thus sojourned from Bremen to New York on the *George Washington*. They spent a week in New York, welcomed by Abraham Brill, seeing their first movie, visiting Central Park, Chinatown, the Lower East Side, Coney Island, the American Museum of Natural History, and the Metropolitan Museum of Art (Freud especially enjoyed the antiquities). At the Psychiatric Clinic at Columbia University, near Riverside Drive overlooking the Hudson River, Freud experienced an embarrassing incident of urinary incontinence. Worried that he might experience another while on stage at Clark, Jung offered to help by analyzing the incident. Freud produced a dream, but the associations to it apparently became too intimate; when Jung pressed, Freud demurred, saying he could not risk his authority by such disclosures. According to Jung's account, this began the break between the two of them.

Freud was ecstatic by the invitation and by the prospect of lecturing to a distinguished American audience. After years of working in "splendid isolation" he found himself "received by the foremost men as an equal. As I stepped on to the platform at Worcester to deliver my *Five Lectures on Psycho-Analysis* it seemed like the realization of some incredible day-dream: psycho-analysis was no longer a product of a delusion, it had become a valuable part of reality. It has not lost ground in America since our visit . . ." (Freud, 1925d, p.52). In the audience were William James (he and Freud walked together and James suffered what was probably an angina attack from the heart disease that was to kill him shortly thereafter), Emma Goldman, and many other notables.

To be spontaneous, Freud delivered the five lectures without notes or extensive preparation; he simply talked with Ferenczi shortly before each lecture about the day's topic. Later, Freud changed the text somewhat before publication by Clark's house organ. Intending a general introduction, Freud discussed hysteria, repression and the talking cure, functions and interpretation of dreams, childhood sexuality, and symptoms. One of the great intellectual events of the century, the trip greatly stimulated the growth of psychoanalysis in the United States: the American Psychoanalytic Association was founded in Baltimore just two years later, years earlier than may have been the case otherwise.

ROBERT SHILKRET

*See also:* Brill, Abraham Arden; *Five Lectures on Psycho-Analysis*; Jones, Ernest; Putnam, James Jackson; United States.

### **Bibliography**

- Cooper, Martha, & Makay, John J. (1988). Knowledge, power, and Freud's Clark Conference lectures. *Quarterly Journal of Speech*, 74, 416–433.
- Freud, Sigmund. (1910 [1909]). Five lectures on psychoanalysis. *SE*, 11: 1–56.
- . (1925). An autobiographical study. *SE*, 20: 1–74.
- Hale, Nathan G., Jr. (1971). *Freud and the Americans: The beginnings of psychoanalysis in the United States, 1876–1917*. New York: Oxford University Press.
- Rosenzweig, Saul. (1992). *Freud, Jung, and Hall the King-Maker: The historic expedition to America (1909)*. Seattle, WA: Hogrefe & Huber.

---

## **CLARK-WILLIAMS, MARGARET (1910–1975)**

A psychologist and psychoanalyst who practiced in France, Margaret Clark-Williams was born in the United States in 1910 to a family of prominent academics; she died in 1975.

At 21 she went first to France, then to Vienna, where she made her initial contacts in psychoanalytic circles. After a period in the United States with her two children, she returned to France in 1945 and began psychoanalysis with Raymond de Saussure, clinical training with Georges Heuyer, and university studies with Daniel Lagache; she also practiced analysis under the supervision of John Leuba. She subsequently worked as a psychotherapist at the recently opened Centre Claude Bernard. Nothing had prepared Clark-Williams, a reserved woman of charm and humor, to become the center of a sensational media affair widely reported in the French press. Major articles on the Clark-Williams Trial, as it became known, appeared in *Le Figaro*, *Paris Presse*, *Combat*, *Le Monde*, and *Libération*.

In March 1950 the official Order of Physicians brought legal action against Clark-Williams for illicit practice of medicine "due to the fact that she practices psychoanalysis and, therefore, medicine." By French law (*l'Ordonnance du 24 septembre 1945*), physicians alone had the right to diagnose and treat illness. However, at the Sorbonne in 1947 Daniel Lagache had

created a *licence* (i.e., master's degree) in psychology, and in 1950 the first graduates sought to put their education to practical use in a therapeutic context.

Meanwhile, a Gaullist cabinet member and non-medical psychoanalyst, Georges Mauco, through the intermediary of the Committees of Population and the Family, had created the Centre Claude Bernard, the first psychopedagogical institution in France, in 1945. The Center boasted two distinctive features. It took account of the fact that the role of emotions had theretofore been neglected in favor of cognitive issues, and it brought the psychoanalyst into the consulting room for the initial interviews. In France this represented the first extension of psychoanalysis into social institutions.

Clark-Williams's trial, which began on December 4, 1951, turned quickly to her advantage. Medically trained analysts attested to her competence and, although she was not a physician, they described her as perfectly qualified to practice psychoanalysis. Dr. Leuba went so far as to request that he sit with the defendant since the accused was one of his former students. Arguments quickly centered on the relationship of medicine and psychoanalysis. Clark-Williams's supporters had no difficulty explaining that, inasmuch as medicine did not officially recognize psychoanalysis, it was in no position to accuse psychoanalysts of practicing medicine illegally.

Analysts Georges Parcheminey and André Berge testified that psychoanalysis did not involve treating an illness but resembled an effort to help a person with "abnormal behavior" to adjust. Daniel Lagache and Juliette Favez-Boutonier suggested that "psychoanalysis is not a medicine but a psychological technique." Jacques Lacan, who did not take part in the trial but became involved at meetings where the issue was debated, offered his view that "it is difficult for doctors to do without the best psychologists."

When the court rendered judgment on March 31, 1952, it ruled to dismiss charges against the defendant. The Order of Physicians appealed and on July 15, 1953, a second verdict found Clark-Williams guilty and imposed the purely symbolic fine of one franc. Contrary to the plaintiffs' intentions, the trial served to advance the cause of psychologists and lay psychoanalysis in France.

GEORGES SCHOPP

*See also:* Berge, André; Bonaparte, Marie Léon; Favez-Boutonier, Juliette; France; Lay analysis; Mauco, Georges; Société psychanalytique de Paris et Institut de psychanalyse de Paris.

### **Bibliography**

- Berge, André. (1975). Nécrologie de Margaret Clark Williams. *Revue française de psychanalyse*, 39 (4), 669–670.
- Freud, Sigmund. (1926). The question of lay analysis. *SE*, 20: 183–250.
- Schopp, Georges. (1990). "L'affaire Clark-Williams ou la question de l'analyse laïque en France." *Revue internationale d'histoire de la psychanalyse*, 3, 199–239.

---

## **CLAUDE, HENRI CHARLES JULES (1869–1946)**

Henri Claude was born in Paris in 1869, where he died in 1946. He was a French physician, psychiatrist, and professor of the chair of mental illness and brain disease at Saint-Anne's Hospital. He played a leading role in introducing psychoanalysis in France.

An assistant to Professor Fulgence Raymond at the Salpêtrière Hospital, he developed an interest in neuropsychiatry. Although committed to the physiological origin of mental disease, he developed an early interest in psychoanalysis. Although we may laugh, like Sigmund Freud, at his ambivalence, nonetheless he was one of the first to accept Freudian theories and to encourage the practice of psychoanalytic psychotherapy in the hospitals where he worked. He was, for example, receptive to the work of Adolf Schmiergeld and was present at the session of the Société de Neurologie on July 4, 1907, when Schmiergeld, together with P. Provotelle, presented "La méthode psychanalytique et les 'Abwehr-Neuropsychosen' de Freud," one of the first serious studies on psychoanalysis in France.

In February 1913 he authored a report on the fourth edition of *Zur Psychopathologie des Alltagslebens* (The psychopathology of everyday life), which concludes: "In short, this book, whose conception is so uncommon in the French literature (however, in this context, the work of Maeder, 1906, should be mentioned) and which is written in an accessible language, should be better known to psychologists and physicians."

When he was appointed the chair at Sainte-Anne in 1922, he apparently removed from his department Eugénie Sokolnicka, the woman Georges Heuyer had

put in charge of psychoanalysis during his tenure, to replace her with René Laforgue. Claude commented, “I ask that this psychoanalytic practice, which is so shocking in some respects, remain strictly within the scope of medicine, and I exclude from these investigations anyone who is not impregnated with the notion of responsibility felt by any physician worthy of the name. . . . The danger is carrying out the risky Freudian transference” (1924).

From August 2 to 7, 1926, Claude attended the Congrès des Médecins Aliénistes et Neurologistes de France et des Pays de Langue Française, which was held in Geneva. During the congress, at which he presented a report on what was then the focus of his psychiatric work, “Démence précoce et schizophrénie,” his young students René Laforgue, Gilbert Robin, and Adrien Borel, accompanied by Mrs. Laforgue, Raymond and Ariane de Saussure, Angélo Hesnard, and Édouard Pichon created the first Conférence des Psychanalystes de Langue Française (Conference of French-speaking psychoanalysts) on August 1, 1926. After 1931 it was in the lecture hall of the Clinique des Maladies Mentales that these conferences took place.

The department of which he was in charge welcomed psychoanalysis, whose therapeutic merits he extolled by publishing, with Laforgue, highly optimistic statistics on rates of recovery. Pierre Mâle became his medical extern in 1920. In 1927 Michel Cénac, one of the doctors who ran the clinic, along with Paul Schiff, Charles-Henri Nodet, Adrien Borel, and many others sought training with Claude. Later, Jean Delay, who was his student in 1939, continued to use psychoanalysis in his own department beginning in 1942. It was Claude who created the first laboratory of psychotherapy and psychoanalysis at the school of medicine at the University of Paris. In December 1931 he appointed Sacha Nacht to be head of the lab.

In 1926 Laforgue wrote to Freud, “I have enclosed the schedule of courses at Claude’s clinic. This will give you an idea of the importance of psychoanalysis in these courses. Starting next year the courses will be given in the main building of the school of medicine.” This was the only source of psychoanalytic training in France prior to the creation of the Institut de Psychanalyse in 1934. Departments of psychology offered no training in psychoanalysis since Georges Dumas, who had worked with Claude, was violently opposed to it.

As director of the review *L’Encéphale*, Claude was a busy editor, publishing a number of articles and

prefaces, including the preface to Roland Dalbiez’s dissertation “La Méthode psychanalytique et la Doctrine de Freud,” in 1936. But it was a preface he wrote in 1924 that later cast an unfavorable light on his character. Here he wrote “By agreeing to present to the medical public the book by Messrs. Laforgue and Allendy on *Psychanalyses et les névroses*, I have not hidden from the authors that it was not my intent to support their opinions. . . . Certain investigative procedures which shock the delicacy of intimate sentiments and of certain habitual ways of looking at things, by means of an extremist symbolism, applicable perhaps with subjects of another race, do not strike me as appropriate in a ‘clinique latine.’” Freud responded to the authors, on June 29, 1924: “I have received your book. Naturally, I haven’t yet read it but after Claude’s preface I see that it must be good, for his reservations prove to me that you have not compromised in any way and were not afraid of being contradicted.”

More serious than these reservations, the presumed eviction of Eugénie Sokolnicka, the threat of his “patronage” to the detriment of Freud’s during the creation of the *Revue française de psychanalyse* in 1927, and his attitude throughout the Occupation, when in 1941 he participated in René Laforgue’s aborted project to create a French section of the Société de Psychothérapie Nazie (Nazi society for psychotherapy), directed by Professor Matthias Göring, diminished any positive elements of his support at a time when just about all French physicians were opposed to psychoanalysis.

Yet, André Breton may have said it best when he wrote: “The essential thing is that I do not suppose there can be much difference for Nadja between the inside of a sanitarium and the outside. There must, unfortunately, be a difference all the same, on account of the grating sound of a key turning in a lock, or the wretched view of the garden, the cheek of the people who question you when you want to be left alone, like Professor Claude at Sainte-Anne, with his dunce’s forehead and that stubborn expression on his face (‘You’re being persecuted, aren’t you?’ No, monsieur. ‘He’s lying, last week he told me he was being persecuted.’ Or ‘You hear voices, do you? Well, are they voices like mine?’ No, Monsieur. ‘You see, he has auditory hallucinations.’)”

ALAIN DE MIJOLLA

See also: Congrès des psychanalystes de langue française des pays romans; Delay, Jean; *Disque vert*, Le; Ey, Henri; *Psychanalyse et les névroses*, La; *Revue française de psychanalyse*; Sainte-Anne Hospital.

### Bibliography

- Claude, Henri. (1913). Zur Psychopathologie des Alltagslebens, par Sigm. Freud, de Vienne (De la psychopathologie de la vie de tous les jours). (4th ed.). Berlin: Lib. S. Karger.
- . (1924, May). Freud et la méthode psychanalytique. *Les nouvelles littéraires*.
- Freud, Sigmund. (1977h). Correspondance Freud-Laforgue, préface d'André Bourguignon. *Nouvelle Revue de psychanalyse*, 15, p. 235–314.
- Laforgue, René; and Allendy, René. (1924). *La psychanalyse et les névroses*. Paris: Payot.

## CLAUSTROPHOBIA

Benjamin Ball introduced the term “claustrophobia” into the field of psychiatric semiology in 1879. It is derived from the Latin *claustrum* (enclosed place) and the Greek *phobos* (fear). Claustrophobia is defined as the fear of enclosed spaces. Faced with the impossibility of escape, the person suffering from claustrophobia fears being suffocated, being crushed, losing consciousness, or losing control of his actions or sphincter muscles. Avoidance techniques are then developed together with counterphobic behavior (being accompanied by another person, carrying a key) or behavioral modifications (opening doors and windows, positioning oneself near an exit).

The word is part of psychiatric semiology. Albert Pitres and Emmanuel Régis (1902) classify claustrophobia as a phobia of place, and Pierre Janet as one of the systematic anxieties constituting psychasthenia. Recent British and American clinical practice includes claustrophobia among the simple phobias, often associated with agoraphobia, which predominantly affect women and are rare in children (Freud, A., 1977).

For Sigmund Freud claustrophobia is one of the phobias of locomotion, similar to agoraphobia. Its metapsychological status evolved along with the development of his theories of anxiety and the construction of phobias. Freud first considered it as one of the chronic symptoms of neurasthenia (Manuscript B, 1893, in 1950a). Later he distinguished it, along with the other phobias, from the obsessions (“Obsessions

and Phobias,” 1895c), ultimately associating it with anxiety hysteria (1905d). In his early writings, he interpreted claustrophobia as the result of an excess of unused libido. He related it to castration anxiety, produced by the repression of oedipal desire. Here, the emergence of free anxiety was displaced and projected onto the phobic object, in this case an enclosed space.

Melanie Klein (1932/1975) believed it involved a projective identification with the dangerous body of the mother, with the anxiety of being enclosed there and castrated by the father’s penis. Bertram D. Lewin (1935) proposed a similar definition of claustrophobia, in which he refers to an unconscious fantasy of return to the maternal breast, accompanied by oral fantasies of being devoured. For Otto Fenichel (1953) the enclosed space that is feared represents the patient’s body and the sensations the patient is trying to get rid of through projection of excess excitation onto the *claustrum*. The phobogenic situation mobilizes infantile anxieties, the fear of solitude, and the temptation to masturbate. François Perrier (1956/1994) saw claustrophobia as being organized like speech, where, symbolically, a key held in the hand enables one to avoid the anxiety, thus escaping the enclosed world of the mother and making access to the father possible. Some authors explored other aspects of claustrophobia, analyzing its associations with depression (Gehl, R. H., 1965) or agoraphobia (Weiss, E. 1964).

LAURENT MULDWORF

See also: Phobic neurosis; Phobias in children.

### Bibliography

- Birraux, Annie. (1994). *Éloge de la phobie*. Paris: Presses Universitaires de France.
- Compton, Allan. (1997). La théorie psychanalytique des phobies. In *Peurs et Phobies* (p. 33–65). Paris: Presses Universitaires de France.
- Gehl, Raymond H. (1965). Dépression et claustrophobie. *Revue française de psychanalyse*, 29 (2–3), 233–255.
- Fenichel, Otto. (1953). Respiratory introjection. In *The collected papers, first series*. New York: W.W. Norton.
- Freud, Anna. (1977). Fears, anxieties, and phobic phenomena. *Psychoanalytic Study of the Child*, 32, 85–90.
- Freud, Sigmund. (1895c [1894]). Obsessions and phobias: their psychological mechanism and their aetiology. *SE*, 3: 69–82.

- . (1905d). Three essays on the theory of sexuality. *SE*, 7: 123–243.
- . (1950a [1887-1902]). Extracts from the Fliess papers. *SE*, 1: 173–280.
- Klein, Melanie. (1975). *The psycho-analysis of children*. In *The Writings of Melanie Klein* (Vol. 2). London: Hogarth. (Original work published 1932)
- Lewin, Bertrand D. (1935). Claustrophobia. *Psychoanalytic Quarterly* 4, 227–233.
- Perrier François. (1994). Phobies et hystérie d'angoisse. In Jacques Sédat (Ed.), *La Chaussée d'Antin* (New rev. ed., p. 300–325). Paris, Albin Michel. (Original work published 1956)
- Pitres Albert, and Régis, Emmanuel. (1902). *Les obsessions et les impulsions*. Paris: O. Doin.
- Weiss, Edoardo. (1964). *Agoraphobia in the light of ego psychology*. New York, Grune & Stratton.

### Further Reading

- Asch, Stuart S. (1966). Claustrophobia and depression. *Journal of the American Psychoanalytic Association*, 14, 711–729.
- Willoughby, Roger. (2001). "The dungeon of thyself": the claustrum as pathological container. *International Journal of Psychoanalysis*, 82, 917–932.

## CLINGING INSTINCT

Imre Hermann presupposes an instinct manifest in primates and latent in human babies, namely, the drive to cling to the mother, which is frustrated from the outset by the absence of biological endowments, but is present in the form of reflexes (grasping, Moro, heat-orientation) in the early stages of development and in later pathological symptoms (e.g., hair-pulling, nail-biting).

Based on the psychoanalytical examination of comparative psychology, Hermann first expounded the theory of the clinging instinct in the study, "Sich Anklammern und Auf-SucheGehen," in 1936. He described the operation of phylogenetic heritage in the mother-child dual union, its integration into the libidinal organization, the relationship of frustrated instinct drives to castration complex, to passively endured separational trauma and active separational drive, to sadism and masochism, to destruction instinct and narcissism. In his book, *The Primeval Instincts of Man* (1943), he expanded the biosocial model theory of human devel-

opment to form the clinging theory. He conducted wide-ranging investigations, starting with primate biology, through clinical facts supported by neurological data, and through developmental psychological data he examined the relationship of the phenomenology of the clinging syndrome to love, anxiety, shame, and, through ego development, to thinking. He also studied ethnology, culture history, and social psychology.

Later ethological researchers (e.g., Harlow and Lawick-Goodall) demonstrated the verisimilitude of Hermann's theories, while John Bowlby's and René Spitz's concepts demonstrated them biosocially. Michel Balint integrated the theory into his concept of primary love.

HUNGARIAN GROUP

See also: Hermann, Imre; Hungary; Hungarian School; Ethology and psychoanalysis.

### Bibliography

- Binet, Agnes. (1977). Comportement d'attachement ou instinct de cramponnement? *Psychiatrie de l'enfant*, 20, 533–564.
- Hermann, Imre . (1943). *Az ember ösi ösztönei*. Budapest: Magvető.
- . (1976). Clinging-searching;contrasting instincts, rel. sadism, masochism," *Psychoanalytic Quarterly*, 45:5–36.
- . (1978). *Psychanalyse et logique*. Paris: Denoël.
- Nemes, L. (1980). Biographical notes of Professor Imre Hermann, *International Review of Psychoanalysis*, 7, 1–2.

## COCAINE AND PSYCHOANALYSIS

Cocaine is an alkaloid extracted from coca leaves, which has been used in medicine for its analgesic and anesthetic properties. Cocaine dependency is an addiction to this narcotic. The relation between cocaine and psychoanalysis goes back to Freud's research in which he used the substance as an ophthalmic anesthetic.

Cocaine was first used as an anesthetic agent in Vienna in 1884. Freud conducted research into the physiological action of the drug with a view to using it for therapeutic purposes. It was nevertheless his colleague, Carl Köller, who continued this work and to whom we attribute the discovery of the anesthetic properties of cocaine, based on its use in eye surgery.

Years later Freud described the situation in these terms: "A side interest, though it was a deep one, had led me in 1884 to obtain from Merck some of what was then the little-known alkaloid cocaine and to study its physiological action....I suggested, however, to my friend Köningstein, the ophthalmologist, that he should investigate the question of how far the anaesthetizing properties of cocaine were applicable in diseases of the eye" (1925d, pp. 14–15). Ernest Jones (1953) reports that in 1884 Freud administered injections of cocaine to his friend Ernst von Fleischl in order to wean him off his morphine addiction and to ease his terrible trigeminal neuralgia. One year later he observed that the massive doses of cocaine required by Fleischl had led to chronic intoxication. He thus discovered the toxicity of cocaine, which stood in the way of its being used medically. Coca leaves and cocaine had been used in the Americas as stimulants to fight fatigue and hunger, but their use led to neurochemical and physiological effects as well as severe addiction problems.

Psychoanalysis has studied the underlying dynamics and the unconscious fantasies that drive patients to seek out the chemical and physiological effects of cocaine in a compulsive manner. Cocaine addiction is normally difficult to cure. Classification of the pathological structures underlying cocaine addiction seems to suggest that a process of pathological mourning or manic-depressive behavior can be found in many patients. Patients sometimes seek out this toxic substance as a stimulant or an anti-depressant in order to conceal states of depression. Some drug addicts unable to work through their grief develop pathological mourning wherein they identify with the lost dead object(s), thus unconsciously putting their lives in grave danger. Their repeated risk taking allows them to feel as if they are conquering death and are being resuscitated. This fantasied resurrection represents success to these addicts, in whose mental state the psychological notions of danger, death, and suicide do not exist. The psychoanalytic interpretation therefore must direct itself to the uncovering and interpreting of their resurrection fantasies and thus lead them to give up living within a dead object or give up identifying with a dead person.

DAVID ROSENFELD

*See also:* Addiction; Alienation; Anorexia nervosa; Borderline conditions; Dependence; Fantasy (reverie); Indications and counterindications for psychoanalysis; Transitional object.

### **Bibliography**

- Freud, Sigmund. (1925d). An autobiographical study. *SE*, 20: 1–74.
- Jones, Ernest. (1953). *Sigmund Freud. Life and work*. London: Hogarth.
- Rosenfeld, David. (1992). *The psychotic aspects of the personality*. London-New York: Karnac Books.

---

## **COGNITIVISM AND PSYCHOANALYSIS**

Ever since the 1960s, an important body of thought has developed in reaction to the presumed behaviorism according to which intellectual activity is beyond the grasp of any form of scientific investigation. Cognitivism has marked a return to a scientific approach to mental activity that has materialized in the development of the cognitive sciences.

The term refers to those sciences that study systems for representing understanding and the processing of information. Included in the term are certain areas of speculative research (philosophy of mind), artificial intelligence, semantic, syntactic, and lexical models (linguistics), the study of human activities (psychology), and the neuronal basis of those activities (neuroscience). These disciplines do not fall entirely within the field of cognitive science (social psychology or the neurobiology of development, for example).

Cognitivism originally developed as an interdisciplinary activity. The work of Jean Piaget on genetic epistemology and the work of Edward Toman on cognitive mapping opened the way in psychology long before Miller, Galanter, and Pribram's seminal work, *Plans and the Structure of Behavior* (1960). The term "artificial intelligence" was coined during a seminar by Herbert Simon.

The application of the methods of cognitive science to the field of psychopathology is more recent (M. C. Hardy-Baylé, 1996) and is based on work in the philosophy of mind and a renewed interest in phenomenology as well as on expert systems in artificial intelligence (models of paranoid thought, Parry), and especially experimental research (anomalies in the processing of information during schizophrenic states or a slowing down of the decision-making process during depressive states).

The development of cognitivism did not fail to arouse suspicion and opposition on the part of

psychoanalysts. Some of their reservations were based on a confusion with so-called cognitive therapies, which in reality have to do with the content of representations (judgment errors) and not the underlying mechanisms. They are based on the use of suggestion, which falls within the domain of behavioral therapy, which in turn draws on behaviorism. More serious reservations involve the fact that cognitivism, which is primarily concerned with understanding, has often neglected the role of affects and has not sufficiently taken into consideration the question of motivation or the role of the body.

For their part cognitive science specialists have contested the scientific value of psychoanalytic theories and, until recently, have had little interest in the area of pathology.

In fact it is easy to show that Sigmund Freud's early work clearly makes use of a cognitive approach (H. K. Pribram, M. Gill, 1968), as does chapter seven of the *Interpretation of Dreams* and a number of later texts. Gradually the emphasis on a dynamic and economic approach shifted the investigation to why rather than how. David Rapaport and, later, Georges Klein resumed the study of thought mechanisms to compare them with experimental results. Their premature deaths and the still strong influence of behaviorism on the psychology of the time explain the delay before psychoanalysts actually got around to confronting these issues directly (P. Holzman, G. Aronson, 1992, D. Widlöcher, 1993).

This confrontation appears to have shocked psychoanalysts, to the extent that they were accustomed to question these disciplines in isolation (psychology, linguistics, logic modeling) and not within an interdisciplinary framework. If psychoanalysis is to assume its place within this framework, the terms of its inclusion must be specified. It would be necessary to acknowledge that psychoanalysis is a unique form of communication and not a science. The knowledge gained from it concerns complex objects that other approaches must first break down into more simple objects.

Such an exchange can benefit the cognitive sciences by exposing them to an area of mental life that has not been explored by them. Psychoanalysis can benefit by escaping the intellectual isolation of their field. It is less obvious how psychoanalytic treatment, as the investigation of the unconscious, can benefit from a

more analytic knowledge of the complex objects it engages.

DANIEL WIDLÖCHER

*See also:* Amnesia; Archetype (analytical psychology); Body; Non-verbal communication; Psychic causality; Psychogenesis/organogenesis.

### **Bibliography**

- Hardy-Baylé, Marie-Christine. (1996). Troubles de l'information et troubles mentaux. In Daniel Widlöcher (Ed.). *Traité de psychopathologie* (pp. 463–496). Paris: Presses Universitaires de France.
- Holzman, Philip, and Aronson, Gerald, (1992). Psychoanalysis and its neighboring sciences: Paradigms and opportunities, *Journal of the American Psychoanalytical Association*, 40 (1), 63–88.
- Miller, George A., Galanter, E., and Karl H. Pribram. (1960). *Plans and the structure of behavior*, New York: Holt, Rinehart & Winston.
- Pribram, Karl H., Gill, Merton M. (1976). *Freud's "Project" reassessed*. London: Hutchinson.
- Widlöcher, Daniel. (1993a). Intentionnalité et psychopathologie, *Revue internationale de psychopathologie*, 10, 193–224.
- . (1993b). L'analyse cognitive du silence en psychanalyse. Quand les mots viennent à manquer, *Revue internationale de psychopathologie*, 12, 509–528.

---

## **COLLECTED PAPERS ON SCHIZOPHRENIA AND RELATED SUBJECTS**

By the time this book was published, Harold F. Searles, M.D., was 47 years old and was already widely regarded as the world's leading authority on the intensive psychotherapy of patients with chronic schizophrenia.

His writings on schizophrenia reveal his unparalleled skill in making contact with severely ill patients, and learning from them not only about schizophrenia, but about the human condition in general. ("Research in schizophrenia has its greatest potential value in the fact that the schizophrenic shows us in a sharply etched form that which is so obscured, by years of progressive adaptation to adult interpersonal living, in human beings in general.") He consistently avoids the temptation to view the patient as the sole repository of psychopathology within the patient-analyst dyad. Thus, he continually focuses not only on the patient's



transference to the analyst, but equally on the analyst's countertransference to the patient.

His many original contributions to the topic of countertransference are among his most significant and widely recognized accomplishments—for example, in discussing dependency conflicts over his regressive dependency needs and omnipotent fantasies, and the role of these countertransference feelings in both motivating the analyst to treat schizophrenic patients, and also in interfering in the psychotherapeutic work.

Searles's papers are unusual for the candor with which he presents his own thoughts and feelings to the reader. For example, in exploring the role of defenses against grief and separation anxiety in the patient's manifest vindictiveness, he writes of a woman who fled her therapy with him to avoid facing her grief over an early loss. Searles adds, "My belief now is that I, too, contributed to the dissolution of the therapy, on the basis of my own anxiety about grief from my early life—an area which, at the time, I had not yet explored at all thoroughly in my analysis."

Another quality which pervades Searles's contributions is his deep and abiding interest in unconscious processes, including those in patient and analyst. He thus remains more faithful to Freud's work than many analysts in the United States.

Searles believes that conflicts over love rather than conflicts over hatred and rejection are more basic in the development of schizophrenia. He contends that the schizophrenic illness represents the patient's "loving sacrifice of his very individuality for the welfare of a mother who is loved genuinely, altruistically, and with... wholehearted adoration." He further maintains that this genuine love, which is mutual, can be difficult to recognize because the patient and mother are unconsciously afraid of their love for each other. He traces this conflict back to the mother's own childhood experiences, which have led her to believe that her love is destructive.

Searles emphasizes the role of symbiotic relatedness between analyst and schizophrenic patient. He believes the treatment of these patients is so prolonged partly because both patient and analyst fear and resist this symbiotic stage of the transference and countertransference. Because of the fluctuating role reversals in this phase of treatment, the analyst must be relatively accepting not only of omnipotent feelings that accompany being in the role of an infant's mother, but also accepting of the infantile dependency feelings that result

from being in the converse role of the infant. Anticipating Kohut, Searles wrote as early as 1958 of the analyst's difficulty in tolerating the patient's adoration: "It requires a sounder sense of self-esteem to be exposed to the patient's genuine admiration, of this degree of intensity, than to face his contempt towards oneself."

"Driving the other person crazy" includes reciprocal efforts to do so between parent and child, as well as between analyst and patient. Lack of integration in one person tends to have an emotionally disintegrating impact on the other person. Motives for driving another person crazy, which are largely unconscious, can include a wish to destroy that person psychologically; a wish to externalize one's own craziness in the other person; a child's wish that the parent's covert craziness would become obvious enough that others would validate the child's perceptions and share the burden of caring for this parent; a wish to individuate or help the other person individuate, which may be experienced by both parent and child as a wish to drive the other person crazy; and finally, Searles especially emphasizes the wish to attain a deeply gratifying symbiotic mode of relatedness with the other person. He notes that an important unconscious motive in the analyst's choice of profession may be the presence of reaction formations to unconscious wishes to drive other people crazy. He speculates that the irrational "schizophrenogenic mother" concept appeals to analysts who are striving to deny their own regressive urges toward symbiotic relatedness.

Searles's influence on psychoanalysis and psychotherapy worldwide has been immense. His genius at discerning and describing unconscious processes in patient and analyst has profoundly enriched our understanding of a wide range of psychopathology, and has made invaluable contributions to the understanding and use of countertransference.

RICHARD M. WAUGAMAN

*See also:* Counter-transference; Mutual analysis; Negative therapeutic reaction; Schizophrenia.

### Source Citation

Searles, Harold F. (1965). *Collected papers on schizophrenia and related subjects*. New York: International University Press.

### Bibliography

Langs, Robert, and Searles, Harold F. (1980). *Intrapsychic and interpersonal dimensions of treatment*. New York: Jason Aronson.

Searles, Harold F. (1960). *The nonhuman environment in normal development and schizophrenia*. New York: International Universities Press.

———. (1979). *Countertransference and related subjects*. New York: International University Press.

———. (1986). *My work with borderline patients*, Northvale, NJ: Aronson.

## COLLECTIVE PSYCHOLOGY

Collective psychology, or human psychological behavior within communities, has been a subject of study in the Bible and among the ancient Greeks, hence since the origins of Western culture. In the nineteenth century, new fields of investigation opened up: schools of anthropology in Great Britain, folk psychology in Germany, and sociology in France. Sigmund Freud's predecessors and contemporaries within these schools of thought were his favorite interlocutors. From the outset, Freud collaborated in his works on individual and collective psychology (see his letters to Wilhelm Fliess dated December 6, 1896; January 24, 1897; and May 31, 1897 [1950a]).

This form of debate, if not actual borrowing, between psychoanalysis and collective psychology continued throughout Freud's work. A vivid and systematic picture thus emerges in which *Totem and Taboo* (1912–1913a) formed the basis for the Schreber case (1911c) and anticipated “On Narcissism: An Introduction” (1914c); in which *Group Psychology and the Analysis of the Ego* (1921c) is a response to *Beyond the Pleasure Principle* (1920g) and paves the way for *The Ego and the Id* (1923b); and in which *The Future of an Illusion* (1927c) and *Civilization and Its Discontents* (1930a [1929]) led Freud to develop and elaborate, between 1923 and 1927, his structural theory (the castration complex, the superego, and the theory of anxiety) in *Inhibitions, Symptoms, and Anxiety* (1926d [1925]).

Some other works also relate to Freud's first topography: *Jokes and Their Relation to the Unconscious* (1905c), a contribution to the study of central European Jewish culture; “Obsessive Actions and Religious Practices” (1907b), the first major analogy between individual and collective psychology; and “‘Civilized’ Sexual Morality and Modern Nervous Illness” (1908d), in which Freud proposes that society reduce cultural sexual repression as a collective

prophylaxis for neurosis. *Moses and Monotheism: Three Essays* (1939a [1937–1939]), one of Freud's last works, brought together and explained the themes developed on collective psychology and went on to analyze Jewish and Christian monotheistic cultures. Finally, there is Freud's work between 1930 and 1932 on U.S. President Thomas Woodrow Wilson (1966).

The nexus between individual and collective psychology is the family, as the origin of the Oedipus complex and of totemism, which connects the transference neuroses with collective manifestations. Previously Freud had investigated more localized analogies of the connection between individual and group, such as analogies between the observances and rituals of obsessive neurotics and those of religion. From *Group Psychology and the Analysis of the Ego* (1921c) on, he proclaimed collective psychology to be part of psychoanalysis and established his metapsychology on this basis. He discussed the libidinal dynamics of the formation and stabilization of groups in *Group Psychology and the Analysis of the Ego* (1921c) and explained the economic point of view in *The Future of an Illusion* (1927c) and *Civilization and Its Discontents* (1930a [1929]), where he related the economic point of view to hatred and fear. The topography characteristic of groups consists of reduced and simplified forms of the individual psychic agencies of the ego, ego ideal, and superego, as a result of the identifying ties that groups impose: “A primary group of this kind is a number of individuals who have put one and the same object in the place of their ego ideal and have consequently identified themselves with one another in their ego” (1921c, p. 116). Depending on the form of authority and its degree of symbolic elaboration, these reductions are more or less extreme—hence the importance of the great man, capable of representing the ideal at the highest level of elaboration. There are three paradigmatic groups: the horde, the matriarchy, and the totemic clan (in political science, they correspond to rule by one person, by a few, and by all). They differ according to type of representative of the ideal, which ranges from the flesh-and-blood leader to such symbolic forms as the totem and the stated ideal, which substitute for the leader after the greater or lesser elaboration of his murder.

Freud created or developed some core concepts in the course of this research: primal ambivalence, narcissism, the Oedipus complex (1912–1913a); identifications, the ego ideal, aim-inhibited drives, sublimation

(1921c); the superego and guilt feelings, dereliction and its consequences, the conflict between Eros and Thanatos (1927c, 1930a); and splitting of the ego, constructions in analysis (1939a).

Criticisms have abounded, impeding work on almost half of the body of Freud's work. Freud's method of analogy (between individual and collective psychic processes) has not been accepted, nor has his dynamic method. Freud's explicit Lamarckism concerning the transmission of mnemic traces in groups has been rejected. Freud has been criticized for a narrow view of religion that ignores its cultural contributions by considering it as a collective neurosis or delusion. Finally, although Freud considered matriarchy at an early stage (1911f), he neglected other similar figures of identification.

Two further qualifications were formulated by Freud himself: collective psychic processes have to be understood in isolation from any form of therapeutic activity; the analysis of these processes requires the analyst to be separated from groups, especially groups to which the subject belongs, which is difficult to achieve.

Psychoanalysis has made a clear contribution to anthropology, yet collective psychology has mainly been used with small groups in clinical practice. The metapsychological, sociological, and political dimensions of Freud's work have yet to be turned to account.

MICHÈLE PORTE

*See also:* Alienation; Anthropology and psychoanalysis; *Christians and Jews: A Psychoanalytical Study*; *Civilization and Its Discontents*; "Claims of Psychoanalysis to Scientific Interest"; "Dreams and myths"; Ego ideal; Fascination; *Group Psychology and the Analysis of the Ego*; Identification; Le Bon, Gustave; Narcissism of minor differences; Otherness; Racism, anti-Semitism, and psychoanalysis; Schiff, Paul; *Totem and Taboo*.

### Bibliography

- Bion, Wilfred R. (1961). *Experiences in groups*. London: Tavistock Publications.
- Freud, Sigmund. (1905c). Jokes and their relation to the unconscious. *SE*, 8: 1–236.
- . (1907b). Obsessive actions and religious practices. *SE*, 9: 115–127.
- . (1908d). "Civilized" sexual morality and modern nervous illness. *SE*, 9: 177–204.

- . (1911c [1910]). Psycho-analytic notes on an autobiographical account of a case of paranoia (*dementia paranoïdes*). *SE*, 12: 1–82.
- . (1911f). "Great is Diana of the Ephesians." *SE*, 12: 342–344.
- . (1912–1913a). Totem and taboo. *SE*, 13: 1–161.
- . (1914c). On narcissism: An introduction. *SE*, 14: 67–102.
- . (1920g). Beyond the pleasure principle. *SE*, 18: 1–64.
- . (1921c). Group psychology and the analysis of the ego. *SE*, 18: 65–143.
- . (1923b). The ego and the id. *SE*, 19: 1–66.
- . (1926d [1925]). Inhibitions, symptoms, and anxiety. *SE*, 20: 75–172.
- . (1927c). The future of an illusion. *SE*, 21: 1–56.
- . (1930a [1929]). Civilization and its discontents. *SE*, 21: 57–145.
- . (1939a [1934–1938]). Moses and monotheism: Three essays. *SE*, 23: 1–137.
- . (1950a). Extracts from the Fliess papers. *SE*, 1: 173–280.
- Freud, Sigmund, Bullitt, William C. (1966b [1930–1932]). *Thomas Woodrow Wilson, twenty-eighth president of the United States: A psychological study*. Boston: Houghton Mifflin.
- Gillibert, Jean. (1985). *Le psychodrame de la psychanalyse*. Paris: Champ Vallon.
- Kaës, René, & Anzieu, Didier. (1976). *Chronique d'un groupe, le groupe du "Paradis perdu": Observation et commentaires*. Paris: Dunod.
- Porte, Michèle. (1998). *Pulsions et politique: Une relecture de l'événement psychique collectif à partir de l'œuvre de Freud*. Paris: Harmattan.

### Further Reading

- Scheidlinger, Stuart. (1990). Internalization of group psychology: the group within. *Journal of the American Academy of Psychoanalysis*, 18, 494–504.
- Tuttman, Saul. (1991). *Psychoanalytic group theory and therapy: essays in honor of Saul Scheidlinger*. Madison, CT: International Universities Press.

---

## COLLECTIVE UNCONSCIOUS (ANALYTICAL PSYCHOLOGY)

The "collective unconscious" is the part of the collective psyche that is unconscious, the other parts being

consciousness of the perceptible world and consciousness itself. The collective unconscious is different from and in addition to the personal unconscious in that it is a stratum of reality that “does not derive from personal experience and is not a personal acquisition but is inborn...universal...[and] more or less the same everywhere and in all individuals.” (Jung, 1934 [1948]).

The term collective unconscious was first introduced by Carl Gustav Jung in 1916 in a talk to the Zurich School for Analytical Psychology entitled “Über das Unbewusste und seine Inhalte.” The German manuscript for this talk was not found until 1961, after Jung’s death. The earliest written appearance of the term was found in the French translation of the Zurich talk published in 1916 in the *Archives de Psychologies* (Jung, 1916).

Jung’s notion of the collective unconscious ranges from a passive repository that records the history of all human reactions to the world to an active substratum that is the ground out of which all reality emerges. The components of the collective unconscious were first said by Jung to be primordial or ancestral images and later archetypes that manifest in consciousness through images, strong affects, and behavioral patterns. When the energies of the collective unconscious break through into consciousness, consciousness itself is altered, and reactions vary from insanity to a significant reordering of major attitudes.

The notion of the collective unconscious first came to Jung from a dream he had in 1909 on board a ship returning from the United States with Freud. The dream depicted a house that had a cellar below the normal cellar and below that a repository of prehistoric pottery, bones, and skulls. “I thought, of course, that he [Freud] would accept the cellars below this cellar [i.e., the personal unconscious], but the dreams [during the writing of his first book, from 1910 to 1912] were preparing me for the contrary” (McGuire, 1989). In fact, Freud acknowledged primordial ancestral patterns but regarded them as simply inheritable traits (Lamarckianism) posited in each individual (the biogenetic law). For Freud such experiences were phylogenetic recapitulations unrelated to a transcendent structure such as the collective unconscious, but for Jung they arise anew from the collective unconscious in each person in each instance just as they did in one’s ancestors.

By 1925 Jung had theorized that the collective unconscious and the external world are opposites between which lies the observing ego which accesses

the collective unconscious through the anima or animus and the world through the persona. The personal unconscious of Freud is regarded as the shadow of the ego. This schema remained unchanged for Jung.

Jung’s collective unconscious can be seen as a variation within the tradition of philosophical idealism. It shares characteristics with the *Apeiron* of Anaximander, the One of Parmenides, and the Forms of Plato. It also calls to mind the *Pleroma* of the Gnostics, the Categories of Emmanuel Kant, and the Will of Arthur Schopenhauer. What justifies Jung’s notion as psychology and not philosophy is his insistence that the collective unconscious is an empirical fact attested to by the common experiences of humankind over many ages and cultures. Jung’s proof is phenomenological, and he avoids claiming a priori truths whether or not he believes they exist.

In spite of his avoidance of ontological affirmations, Jung often appears to suggest that the collective unconscious is a metaphysical reality, which invites less sophisticated analysts to engage in ideological thinking and inflated claims to transcendent knowledge. In his review of Jung’s autobiography, Winnicott says that the positing of a collective unconscious results from Jung’s split psyche and “was part of his attempt to deal with his lack of contact with what could now be called the unconscious-according-to-Freud.” (Winnicott, 1964) With this criticism, Winnicott dismissed Jung’s and perhaps all efforts to speculate about and derive heuristic guidelines consonant with an ultimate ground against which lie subjectivity, consciousness, and the very mystery of life. As Jung points out, the alternative is a void (Jung, 1948).

DAVID I. TRÉSAN

*See also:* Amplification; (analytical psychology); Anima-animus (analytical psychology); Archetype (analytical psychology); Desoille, Robert; Event; Midlife crisis; psychology of the unconscious; Numinous (analytical psychology); Shadow (analytical psychology); Transference (analytical psychology).

### **Bibliography**

- Jung, Carl Gustav. (1916). The structure of the unconscious, *Coll. works*, vol. VII, London: Routledge & Kegan Paul.
- . (1931–34). The practical use of dream analysis. *Coll. Works*, vol. VIII, London: Routledge & Kegan Paul.

———. (1934 [1948]). A review of the complex theory. *Coll. works*, vol. VIII, London: Routledge & Kegan Paul.

———. (1947 [1954]). On the nature of the psyche, *Coll. works*, vol. VIII, London: Routledge & Kegan Paul.

———. (1948). On the conception of psychic energy and the nature of dreams. Zurich: Rascher Verlag.

McGuire, William. (1989). *C.G. Jung, Analytical psychology, Notes of the seminar given in 1925*. Princeton: Princeton University Press.

Winnicott, Donald W. (1963). *Memories, dreams, reflections*. By C.G. Jung. London, Collins & Routledge, 1963. *International Journal of Psycho-Analysis*, 45, 450–455.

## COLLÈGE DE PSYCHANALYSTES

The Collège de Psychanalystes was founded on November 3, 1980, by a group of psychoanalysts (roughly thirty) from different backgrounds upon the initiative of Dominique Geahchan (1925–1983), François Roustang, Jacques Sédât, Conrad Stein, and Serge Viderman, who drafted the by-laws. There were no founding members. The organization's goal, beyond that of existing analytic institutions, was to consider the role of psychoanalysis in society and defend the analytic approach against the risks of governmental regulation or the shifts in practice arising from mental health coverage. Membership was simple, and involved only approval by a majority of the members. This removed any problems associated with qualifications, which, along with training, were relegated to the various psychoanalytic organizations. Its originality lies in the way it enabled analysts from different organizations and with different backgrounds (members of the International Psychoanalytic Association, its critics, Lacanians) to work together on issues of psychoanalysis and society.

The Collège at times had more than a hundred members, including both French and a handful of Canadian members. Beginning in November 1981 it began publishing a review, *Psychanalystes*, at the request of its first president, Dominique Geahchan, who was also cofounder of *Confrontation* with René Major in 1974, and a member of the Société Psychanalytique de Paris. The review remained in print until March 1994; a total of forty-eight issues on the role of psychoanalysis in society were published.

Problems arose, however, over the question of membership, which gradually evolved into a form of

licensing, and finally the question of social issues and anti-Semitism, the offshoot of a conference devoted to Rudolf Binion's psychohistorical work on Hitler held on June 18, 1992, caused further friction within the organization. This led to a series of group and individual resignations from the Collège and engendered a climate of crisis, culminating in the dissolution of the organization in June 1994.

JACQUES SÉDAT

See also: France.

### Bibliography

Geahchan, Dominique. (1986). *Temps et Désir du psychanalyste*. Paris: InterÉditions.

## COLLOQUE SUR L'INCONSCIENT

The Colloque sur l'inconscient, organized by Henri Ey and devoted to the problems associated with the concept of the unconscious, took place at the end of October 1960, at the Bonneval Psychiatric Hospital, Bonneval, France. The proceedings, published in an octavo volume of more than four hundred pages in 1966, remains one of the most important works on psychopathology of the second half of the twentieth century. Previous colloquia at Bonneval include "Neurologie et Psychiatrie" in 1943, organized by Julian de Ajuriaguerra and Henri Hécaen, and "La Psychogenèse des Névroses et des Psychoses" in 1946, organized by Lucien Bonnafé, Sven Follin, Jacques Lacan, and Julien Rouart.

The first part of the book discusses the associations between the unconscious and the drives, and includes papers by Serge Lebovici and René Diatkine and by François Perrier. Part 2 covers the unconscious and language, and contains papers by Jean Laplanche and Serge Leclair and by Conrad Stein. In the discussion Maurice Merleau-Ponty introduced his books *The Visible and the Invisible* and *The Prose of the World*, and Jacques Lacan, who has an article in the book. Just seven years after the Rome Congress (1953), he positively and polemically laid out his ideas on the central role of language in the formation of the subject (self) and the structuring of the unconscious. Part 3 includes articles on interrelations between our understanding of neurobiology and the question of the unconscious, with a paper by Claude Blanc and another by Catherine G. Lairy. There follows discussion by Paul Guiraud, René Angelergues, Maurice Dongier, Eugène Minkowski,

Jean Hyppolite, and André Green. Part 4 covers the role of the unconscious in psychiatric problems and includes articles by Henri Ey, S. Follin, and André Green, followed by discussion by Jean Hyppolite, Eugène Minowski, and Jean Laplanche. Part 5, on the unconscious and sociology, contains papers by Henri Lefèbvre and by Conrad Stein. The last part of the book concerns the relations between the unconscious and philosophical thought, and includes articles by Alphonse d'Waelhens, Georges Lantéri-Laura, and Paul Ricoeur.

According to the participants, the published texts accurately reflect the content of the actual proceedings. The event provided an opportunity to compare two different concepts of psychoanalysis and to discuss connections among mental pathology, the unconscious, the role of society, brain activity, and some epistemological issues. Although dated, none of the articles in the collection have lost any of their relevance.

GEORGES LANTÉRI-LAURA

*See also:* Ey, Henri; France; Lacan, Jacques-Marie Émile.

### **Bibliography**

Ey, Henri (Ed.). (1966). *L'Inconscient, 6e Colloque de Bonneval, 1960*. Paris: Desclée de Brouwer.

---

## **COLOMBIA**

The history of the Colombian Psychoanalytic Society and Institute has been influenced by the scientific cultural currents of the rest of the world, especially France, England, the United States, Argentina, and Chile.

Between 1922 and 1940, some physicians and other non-physicians traveled to Europe and around Latin America, getting direct contact with Freud or being psychoanalyzed. After the Second World War, three physicians arrived from France and Chile: Drs. José Francisco Socarras (1906–1995), Arturo Lizarazo (1915–1992), and (from Venezuela) Herman Quijada, born in 1915.

By that time eight more physicians had gone to Argentina to be trained in psychoanalysis, while others went to the United States and France. The three immigrants begun to conduct studies of Freud, Numberg, and Klein, beginning analytical supervisions that differed from personal analysis.

Between 1948 and 1950, a prestigious Argentine analyst, Dr. Arnaldo Rascovsky, visited Bogotá and edited the bylaws to be followed for the formation of a Study Group recognized by the IPA. On May 6, 1956, the Study Group was officially founded and was recognized by the IPA a year later, being sponsored by France and Chile.

In 1959, an Associate Member of the Argentine Psychoanalytic Association, Dr. Carlos Plata, arrived to Bogotá who elaborated the Group bylaws. In 1960, Angel and Betty Garma visited Colombia and held a series of seminars as well as individual and collective supervisions, and later in 1961 the Society was recognized by the IPA.

In 1962 a conflict arose between the two pioneers of psychoanalysis in Colombia, which appeared to be political-ideological and ended with the resignation of Arturo Lizarazo, but he left the Colombian Psychoanalytic Association to found his own Study Group, now recognized by the IPA, which is led by M. Gonzalez, J.A. Marquez and R. De Zubiría. Also the “Sigmund Freud Psychoanalytic Group I.P.A.” is led by G. Arcila and B. Alvarez.

In Colombia there are other psychoanalytic Groups in Cali, Medellín, and Bogotá, with some leaders (O. Espinosa, A. Villar) trained at the Colombian Psychoanalytic Society, but the groups are not recognized by the IPA.

Since 1976, the *Review of the Colombian Psychoanalytic Society (Revista de la Sociedad Colombiana de Psicoanálisis)* has appeared, with 21 volumes, four numbers each year, and there is also a “Boletín” published monthly. As of 2002, the Society had four honorary members, 33 full members, 57 associate members. The Institute has 15 training analysts, 10 professors, 14 candidates; there have been 19 graduating classes from 1959–1996. The Institute requires eight semesters (four years training) with two hours daily and two individual supervisions weekly. Freud is the main author studied, but others are reviewed, especially from France, England, the United States, and Argentina, with a multi-theoretical frame of reference. There are members of the Society working in the cities of Cali and Buaramanga.

Various members of the Colombian Psychoanalytic Society have participated in the COPAL, FEPAL, and IPA boards.

Several theoretical and technical contributions have been published, mainly in the *Journal* and in books. The

practice has increased daily, and some analysts are professors at different universities. Psychoanalysis has been admitted at the National Academy of Medicine and is generally well accepted by Colombian society, as well as in scientific reviews and daily journals. Among other well-known contemporary analysts are G. Ballesteros, E. Gómez, E. Laverde, A. Sánchez, I. Villarreal, and L. Yamín.

GUILLERMO SÁNCHEZ MEDINA

### **Bibliography**

- Brainsky, Simon. (1984). *Manual de psicología y psicopatología dinámica fundamentos de psicoanálisis*. Bogotá: Ed. Pluma.
- Carvajal, Guillermo. (1993). *Adolecer: La aventura de una metamorfosis. Una visión psicoanalítica de la adolescencia*. Bogotá: Printing Service Network.
- González Velásquez, Mario. (1993). *La cohesión del self*. Bogotá: Ed. Guadalupe Ltda.
- Plata Mújica, Carlos. (1989). *Metapsicología y Técnica Psicoanalítica*. Bogotá: Ed. Tercer Mundo Editores.
- Sánchez Medina, Guillermo. (1994). *Técnica y clínica psicoanalítica*. Bogotá: Ed. Centro Profesional Gráfico Ltda.
- . (1991). *Psicoanálisis, ayer, hoy y mañana*. Bogotá: Ed. Gaviota.

## **COMBINED PARENT FIGURE**

The combined parent figure is an early and primitive version of Freud's concept of the primal scene. Those phantasies however were believed to supervene at a later stage of development.

In the powerful phantasies of the early Oedipus complex the infant has terrifying experiences of the parents engaged in a particularly violent and dangerous kind of intercourse (Klein, 1928/1975).

Melanie Klein discovered in the panics and night terrors of childhood the persisting of the infant's phantasies of the parents in intercourse. These have a violent tone that matches the violence the infant feels towards the parents at the sense of exclusion.

These phantasies are of pre-genital kinds. For instance the parents may be experienced as mutually feeding each other, which then, in response to the child's hatred, come to be phantasies of the parents devouring each other (Klein, 1929). The imagined mutual destruction is usually extremely worrying for the child, and exclusion may be replaced by a helplessness.

Later in development the infant experiences the parents in more realistic ways, and gains reassurance from the evidence of their survival. At the same time the infant may internalize one or other parent (or perhaps both) to keep them safe. Another primitive response is to mobilize genital feelings of a loving kind, in order to mitigate the violence in himself and perceived in the parental figure. The latter, eroticizing defense may result later in precocious and perverse sexuality.

With the onset of the depressive position, the parents are more realistically appreciated and their relationship can slowly be tolerated as a creative one in its own right. Internalization of a creative parental couple is an important basis of new developments. Tolerating the parents internally in intercourse is an achievement that allows creativity and intellectual curiosity to develop freely.

In Klein's view those later phantasies and investigations which Freud described are emotionally colored by the preceding phantasies of the combined parent figure.

Doubt has been shed on the capacity for infants to have such detailed phantasies and, it is argued, they are to be regarded as subsequent elaborations at a later stage of development when three-person situations can be conceived.

ROBERT D. HINSHELWOOD

*See also:* Breast, good/bad object; Imago; Object, change of/choice of; Oedipus complex, early; Phallic mother; Primal scene.

### **Bibliography**

- Britton, Ron, Feldman, Michael, and O'Shaughnessy, Edna. (1989). *The Oedipus complex today*. London: Karnac Books.
- Klein, Melanie. (1975). Early stages of the Oedipus conflict. In *The writings of Melanie Klein* (Vol. 1, 186–198). (Reprinted from *International Journal of Psycho-Analysis*, 9 (1928), 167–180.)
- . (1929). Infantile anxiety situations reflected in a work of art and in the creative impulse. In *The writings of Melanie Klein* (Vol.1, p. 210–218). London: Hogarth. (Reprinted from *International Journal of Psycho-Analysis*, 10 (1929), 436–443.)
- . (1975). *The psycho-analysis of children*. In *The writings of Melanie Klein* (Vol. 2). London: Hogarth. (Original work published 1932)

## COMPENSATION (ANALYTICAL PSYCHOLOGY)

Compensation (transcendent function) finds its origins in the delineation of dynamics of the complex.

In 1907 Carl Gustav Jung notes the pathogenic complex possesses a quantum of libido which grants it a degree of autonomy that is opposed to conscious will. Though this dynamic has a pathological cast, it conveys the essence of what Jung termed compensation; namely, the capacity of the unconscious to influence consciousness.

Jung noted the ego identifies with a preferred set of adaptive strategies, and thus tends to restrict the range of adaptive response and hamper individuation. In “The Importance of the Unconscious in Psychopathology” (1914), he introduced the idea, saying, “the principal function of the unconscious is to effect a compensation and to produce a balance. All extreme conscious tendencies are softened and toned down through a counter-impulse in the unconscious.” (1914a). This assertion ascribes a different role to unconscious dynamics, i.e. one that is purposive and intelligent, and not restricted solely to wishing.

In 1917, Jung expanded his notion of an intelligent unconscious further when he asserted the existence of a “supraordinate unconscious” as a common human inheritance, viewed as the source of compensatory activity.

Later, Jung referred to compensation as “an inherent self regulation in the psychic apparatus.” Jung’s assertion of an intelligent unconscious culminated in his concept of the self (1928a), understood as the personality’s central organizing agency that instigated and guided individuation. Paired with the concept of the self, compensation was seen as the core process in realizing selfhood.

Given this core value, Jung sought a means to maximize its efficiency and benefits. He termed this means the “transcendent function,” described as a joining of the opposing tendencies of conscious and unconscious that would produce a synthesis in the form of a “uniting symbol” in order to release compensatory contents of the unconscious. Jung, noted the transcendent function facilitated a transition from one attitude to another and held the person skilled with understanding of conscious and unconscious interaction and its symbolic products could accelerate individuation.

PETER MUDD

*See also:* Animus-Anima (analytical psychology); Interpretation of dreams (analytical psychology); Projection and “participation mystique” (analytical psychology).

### Bibliography

- Jung, Carl Gustav. (1907). The psychology of *Dementia praecox*. *Coll. works*, vol. III, London: Routledge & Kegan Paul.
- . (1914a). On the importance of the unconscious in psychopathology. *Coll. works*, vol. III, London: Routledge & Kegan Paul.
- . (1917–18–26–43). The psychology of the unconscious processes. *Coll. works*, vol. VII: London, Routledge & Kegan Paul.
- . (1928a [1935]). The relations between the ego and the unconscious. *Coll. works*, vol. VII, London: Routledge & Kegan Paul.
- . (1928b [1948]). On psychic energy. *Coll. works*, vol. VIII, London: Routledge & Kegan Paul.
- . (1928c [1948]). General aspects of dream psychology. *Coll. works*, vol. VIII, London: Routledge & Kegan Paul.
- . (1928d [1948]). Instinct and the unconscious. *Coll. works*, vol. VIII, London: Routledge & Kegan Paul.

## COMPENSATORY STRUCTURES

Compensatory structures are complex psychological configurations that are an integral part of the overall self or the personality of an individual. As their name indicates, they compensate for certain primary structural deficits in the self, and they do this by activating another structure. Thus, when the mirroring pole, the idealizing pole, or the pole of twinship/alter ego of the self are deficient or underdeveloped, one of the other three becomes the dominant force in the functioning of the self of the person in question.

The deficiencies come from the developmental failures of early childhood concerning self-object experiences, and thus the self’s development. Compensatory structures derive from more optimal self-object relations. They are different from defensive structures, which serve merely to protect the self from any further wound. Compensatory structures go beyond this to become more or less independent of any protective purpose and thus intervene in a gratifying, vitalizing way: they become the self’s main way of orientating itself. Thus, they transcend the fragility of the original



structural deficiency, which then becomes resistant to any analytical intervention. Compensatory structures make up for the deficit, whereas defensive structures cover it over.

Though defensive structures can and must be analyzed to reach into and make up for the structural deficit that they protects, compensatory structures cannot and must not be analyzed in an attempt to bring to light the underlying deficiency. In *The Restoration of the Self*, Kohut says that a successful analysis is one that enables a compensatory structure to be fully developed and consolidated. One neither can nor should try to determine or direct the course of such an analysis, insofar as the development of the self remains a multi-potential process that draws on and chooses from the stock of available self-objects. Instead of deciding that all defenses should be analyzed, it might well be that analytical activity is not indicated for the compensatory structure.

ARNOLD GOLDBERG

*See also:* Self; Self-object.

### **Bibliography**

Kohut, Heinz. (1977). *The restoration of the self*. New York: International Universities Press.

---

## **COMPLEMENTAL SERIES**

In *The Language of Psychoanalysis*, Jean Laplanche and Jean-Bertrand Pontalis give the following definition of complementary series: “Term used by Freud in order to account for the aetiology of neurosis without making a hard-and-fast choice between exogenous and endogenous factors. For Freud these two kinds of factors are actually complementary—the weaker the one, the stronger the other—so that any group of cases can in theory be distributed along a scale with the two types of factors varying in inverse ratio. Only at the two extremities of such a serial arrangement would it be possible to find instances where only one kind of factor is present” (1967).

The concept is most clearly explained by Freud in the *Introductory Lectures on Psychoanalysis* (1916–17a [1915–17], p. 347 and note). The endogenous factor corresponds to the fixation points specific to each person (and determined by that person’s hereditary constitution and childhood experience), while the exogenous factor corresponds to frustration. Freud

returned to this question, apropos of trauma, in the last part of *Moses and Monotheism* (1939a [1934–38]): “In this way we reach the concept of a sliding ‘complemental series’ as it is called, in which two factors converge in fulfilling an aetiological requirement. A less of one factor is balanced by a more of the other” (p. 73).

The concept of “complemental series” thus appears in Freud’s work in relation to two key themes, neuroses and traumas, a fact that underscores its importance. It would be interesting to look at this concept from the standpoint of Freud’s renunciation of his *neurotica* in 1896, that is to say, the change he introduced in the etiology of the neuroses from the theory of a real trauma to that of an imagined trauma.

As we know, Sigmund Freud may never have abandoned the theory of the real trauma, and there is a sense in which the concept of “complemental series” testifies to the very real effort he made to reconcile internal and external factors and thus transcend the opposition between external reality and psychic reality. In a way the complemental series foreshadows our more modern and still debated polyfactorial model of pathological etiology.

BERNARD GOLSE

*See also:* Constitution; Internal/external reality; Psychic causality; Psychogenesis/organogenesis.

### **Bibliography**

Freud, Sigmund. (1916–17a [1915–17]). *Introductory lectures on psycho-analysis*. *SE*, 15–16.

———. (1939a [1934–38]). *Moses and monotheism: three essays*. *SE*, 23: 1–137.

---

## **COMPLEX**

A complex is a group of partially or totally unconscious psychic content (representations, memories, fantasies, affects, and so on), which constitutes a more or less organized whole, such that the activation of one of its components leads to the activation of others.

Freud did not coin the term “complex.” At the end of the nineteenth century, it was occasionally used in psychiatry to designate a collection of ideas belonging to a subject. Freud used it in this sense in 1892 in a sketch written in preparation for his “Preliminary Communication.” He wrote that in hysteria, “the content of consciousness easily becomes temporarily dissociated and certain complexes of ideas which are not

associatively connected easily fly apart” (1940–41 [1892], p. 149). Shortly after, he used the term again in *Studies on Hysteria* (1895d), specifically in the case of Emmy von N. Josef Breuer, coauthor of the *Studies*, wrote, “It is almost always a question of *complexes* of ideas, of recollections of external events and trains of thought of the subject’s own. It may sometimes happen that every one of the individual ideas comprised in such a complex of ideas is thought of consciously, and that what is exiled from consciousness is only the particular combination of them” (1895d, p. 215n).

In the ensuing years, the idea that at the heart of a neurosis there was a collection of ideas and affects specific to the subject and organized around a traumatic sexual experience became central to the development of psychoanalysis—even though subsequently Freud rarely used the term “complex” to designate such a set of ideas. He did add an essential modification to the previous psychiatric conception in positing that, for the most part, such a collection is made up of unconscious processes and remains unconscious itself.

In 1906 he explicitly discussed the term “complex” for the first time in an article on “Psycho-Analysis and the Establishment of Facts in Legal Proceedings” (1906c). He paid homage to Eugen Bleuler, and more particularly to Carl Gustav Jung, whom he had just met, and praised the method of “word association,” which was developed by Wilhelm M. Wundt and practiced by Jung. This experimental method consisted of giving a subject a series of “stimulus words” and asking the subject to react as quickly as possible. The time that it takes the person to respond and the nature of their response are assumed to indicate a “complex.” Freud, in this work, defined a complex as “ideational content” charged with affect (p. 104).

From then on, he used the term frequently to designate the “nuclear complex of neurosis,” that is, “the father complex” (1909d, p. 208n; p. 200ff.), which he designated as the “Oedipus complex” starting in 1910 (1910h, p. 171). Similarly, he began to speak of the “castration complex” (1909b, p. 8).

After he split with Jung, Freud withdrew the praise that that he previously bestowed upon him. Thus he wrote, in his *History of the Psycho-Analytic Movement* (1914d), that the “theory of complexes” proposed by Jung did not actually attain the status of a theory and had not “proved capable of easy incorporation into the context of psycho-analytic theory” (p. 29), even

though the term itself had become common in psychoanalytic usage. In other words, Freud adopted the term to give meaning to his own metapsychological constructions, but rejected the theory of Jung himself.

The following points should be emphasized:

1. There is an obvious difference between the popular use of the term “complex” in contemporary culture and its more specific usage in the psychoanalytic literature. In this regard, what Freud described in 1914 remains the same today: “None of the other terms coined by psycho-analysis for its own needs has achieved such widespread popularity or been so misapplied to the detriment of the construction of clearer concepts” (1914d, pp. 29–30). In contemporary psychoanalytic writings, the term is hardly ever encountered anymore except in two closely connected situations: references to the Oedipus complex and the castration complex.
2. As surprising as it may seem, there has been scarcely any coherent theoretical reflection on the notion of the “complex” as such, except insofar as it is related to other terms used to designate an organized set of mental processes and activities (“structure” and “system,” for example). The difficulty arises from the need to distinguish and yet coordinate two different levels. The first describes the structure of the psyche as being the same, at least in its broad outlines, in every human being; such features would be, at least in theory, constitutive of the psyche itself (this is the case with the Oedipus complex and its corollary, the castration complex). The other level is that of individual variations, that is, the particularities of such a fundamental structure taken as a function of personal history, of imagos, of the play of identification, etc. The study of such particularities is the very object of psychoanalytic treatment. But the temptation to group complexes into “families” led over time to the proliferation of “new complexes,” generally named after mythological figures. There was the “Electra complex,” the supposed feminine version of the Oedipus complex; the “Jocasta complex,” which designated the maternal counter-Oedipus; and even the “Ajase complex,” which referred to the guilt that is linked in Japanese culture to the desire to kill the mother (Kosawa, 1931/1954). Thus there is a danger of falling into a purely descriptive typology in which the coherence of

the Freudian metapsychology disappears and its explanatory power is lost. But in fact, not one of these proposed complexes has survived.

3. Insofar as it relates to a fundamental structure, a complex is in itself not characteristic of this or that neurosis. Only its functionally disruptive manifestations and fixations can rise to the level of pathology.

In the definitions given above, a complex is “a group of ideas.” Josef Breuer correctly noted that these ideas could be or could become conscious, but that what is “exiled from consciousness” is their “particular combination.” However, we cannot remain at the level of ideas in the strict sense: memory traces, fantasies (at every level, from conscious to unconscious), and imagos, for example, all enter into this “combination.” Moreover, what accounts for the effect of the complex is its quota of affect, and also its drive force. Thus, the study of an individual complex in the treatment leads to a topological consideration of all the related defenses and the retroactive reworkings that combined to set up a functional structure of this kind.

ROGER PERRON

*See also:* Compensation (analytical psychology); Complex (analytical psychology); Ego (analytical psychology); Femininity; Nuclear complex; Oedipus complex; Oedipus complex, early; Projection and “participation mystique” (analytical psychology); *Psychology of Dementia praecox*; Word association.

### Bibliography

- Freud, Sigmund. (1906c). Psycho-analysis and the establishment of facts in legal proceedings. *SE*, 9: 97–114.
- . (1909b). Analysis of a phobia in a five-year-old boy. *SE*, 10: 1–149.
- . (1909d). Notes upon a case of obsessional neurosis. *SE*, 10: 151–318.
- . (1910h). A special type of choice of object made by men. *SE*, 11: 163–175.
- . (1914d). On the history of the psycho-analytic movement. *SE*, 14: 1–66.
- . (1940–41 [1892]). Sketches for the “Preliminary Communication” of 1893. *SE*, 1: 147–154.
- Freud, Sigmund, and Breuer, Josef. (1895d). Studies on Hysteria. *SE*, 2: 48–106.
- Kosawa, Heisaku. (1954). Two kinds of guilt feelings: the Ajase complex. *Japanese Journal of Psychoanalysis*, 11. (Original work published 1931)

## COMPLEX (ANALYTICAL PSYCHOLOGY)

A complex is the more- or less-repressed standardization of emotionally strong conflictual experiences. When these experiences are triggered, either by certain themes (such as new pieces of information), or emotions (in which case they are called “constellations”), the complex produces a reaction, such that the individual perceives the situation in terms of the complex (with a distortion of perception), and responds with an emotional overreaction, which mobilizes the processes of stereotyped defense.

Carl Gustav Jung developed his concept of the complex at the same time as he was engaged in his experiments with association. It is within this context that the concept appeared for the first time, in 1904, in an essay called “*Experimentelle Untersuchungen über Assoziationen Gesunder*” (“The associations of normal subjects,” with Franz Riklin). But he had already used the term, without any particular specificity, in his thesis of 1902.

When, at the turn of the century, Jung and Riklin eagerly turned to research on association in order to construct typologies, they studied what they considered normal disturbances of experience. They showed that a test subject could not uniformly form associations with ideas that were attached to highly emotionally-charged experiences and personal difficulties. They went on to hypothesize that such complexes might constitute the background of consciousness, and that in any neurosis of psychical origin, there would be a complex characterized by a particularly strong emotional charge.

Later, in 1907, Jung established that any event charged with affect gives rise to a complex and reinforces those that are already in place. Complexes act from the unconscious and can at any moment either inhibit, or on the contrary, activate conscious behavior. They reveal conflicts, but are also defined by Jung as crucial hot points of psychic life.

In 1934, Jung summarized his theory of complexes and emphasized that, even outside of the effects of any individual constellation, complexes involve the active forces that determine the interests of everyone and thus serve as the basis for the symbol formation. This conception of complexes, which he continued to develop afterwards, led him to emphasize their creative effects. From a therapeutic perspective, this is an important aspect of his psychology and his clinical work. From it

he developed the idea of promoting creative development through the integration of complexes. This idea plays a large role in many of the techniques developed by the Jungian school. Finally, it is from this insight that Jung came to see archetypes at the heart of complexes.

The experiments in association, as well as the concepts of the complex-ego, of the symbol and the archetype, imagination and emotion, and transference and counter-transference, all refer to Jung's idea that the complex is caused by the painful confrontation of the individual with the "necessity to adapt." Thus the very concept of complexes takes on an even more dynamic dimension: each one appears as an effect of the condensation and generalization of experiences that might, at any moment, be associated by analogy with a new piece of information or emotion. This is why the concept takes on decisive importance for understanding what is at play in the transference and the counter-transference.

VERENA KAST

*See also:* Castration complex; Dead mother complex; "On the History of the Psychoanalytic Movement"; Libidinal development; Ethnopsychanalysis; Identification; Imago; Masculine protest (analytical psychology); Penis envy; Phallus; Primal fantasies; Primitive horde; *Psychanalyse et Pédiatrie* (psychoanalysis and pediatrics); *Psychoanalysis of Fire, The*; Repression; Sexual differences; Structural theories; Word association; Word-Presentation.

### **Bibliography**

- Jung, Carl Gustav. (1902). On the psychology and the pathology of the so-called occult phenomena. In *Coll. works*, vol. I. London: Routledge & Kegan Paul, 1957.
- . (1904). The associations of normal subjects. In *Coll. works*, vol. II. London, Routledge & Kegan Paul.
- . (1907). The psychology of *dementia præcox*. In *Coll. works*, vol. III. London: Routledge & Kegan Paul.
- . (1934 [1948]). A review of the complex theory. In *Coll. works*, vol. VIII. London: Routledge & Kegan Paul.
- Kast, Verena. (1992). *The Dynamics of Symbols: Fundamentals of Jungian Psychotherapy*. (Susan A. Schwarz, Trans.). New York: Fromm International Publishing Corporation.

## **COMPROMISE FORMATION**

In dreams, just as in symptoms formation, "we find a struggle between two trends, of which one is

unconscious and ordinarily repressed and strives towards satisfaction—that is, wish-fulfillment—while the other, belonging probably to the conscious ego, is disapproving and repressive. The outcome of this conflict is a *compromise-formation* (the dream or the symptom) in which both trends have found an incomplete expression" (Freud, 1923a, p. 242).

This definition was given by Freud in an encyclopedia article called "Psycho-Analysis." In it he refers to both a dynamic process (the drive/defense conflict) and to its result. The term "compromise" emphasizes that it is a partial satisfaction that is achieved (as the mechanism of the daydream illustrates), which, within the general framework of the theory of symptom formation differentiates this concept from similar notions such as substitutive formations and reaction formations.

The term first appeared in 1896 in "Further Remarks on the Neuro-Psychoses of Defense" in relation to the mechanisms of obsessional neurosis: obsessive representations and compulsive acts are "what become conscious as obsessional ideas and affects, and take the place of the pathogenic memories as far as the conscious life is concerned. . . . [They] are structures in the nature of a *compromise* between the repressed idea and the repressing ones" (p. 170). It was later extended by Freud beyond obsessional neurosis to the entire dynamics of the psyche as a major component of the process of symptom formation (1916–17a, Lecture 23), and then reconceived within the structural theory. It was this new formulation that was taken up again in *Moses and Monotheism* (1939a).

Is every compromise formation a return of the repressed? Or could we say that compromise formation could result from other defensive mechanisms, such as negation and even disavowal? This question wasn't explicitly raised by Freud, but it could be posed in light of modern work.

*See also:* Contradiction; Fantasy, formula of; Flight into illness; Parapraxis; *Psychopathology of Everyday Life, The*; Reaction-formation; Substitutive-formation; Symbolism; Symptom-formation.

### **Bibliography**

- Freud, Sigmund. (1896b). Further remarks on the neuro-psychoses of defence. *SE*, 3: 157–185.
- . (1916–17a). Introductory lectures on psycho-analysis, parts I and II. *SE*, 15–16.

———. (1939a). Moses and monotheism: Three essays. *SE*, 23: 1–137.

———. (1923a). Two encyclopaedia articles: psycho-analysis and the libido theory. *SE*, 18: 233–259.

## COMPULSION

Compulsion is a mental pressure of internal origin compelling the subject to think, act, or react in accordance with specific modalities that do not coincide with his habitual patterns of thought. Freud used the German term *Zwang* to describe this concept. In an article written in French in 1894 (“*Obsessions et phobies*”), Freud used an equivalent term, obsession. The word “compulsion,” attested in French as early as 1298, is derived from the Latin *compulsio* and originally signified a “constraint, a legal summons, or formal notice to pay.” “Constraint” is somewhat older (twelfth century) and has the same legal connotation found in the expression “physical constraint.” As for the term “obsession,” which appeared later, its origin is both religious (possession) and military (siege). All three terms were used in the early literature on psychoanalysis to take into account the corresponding complex phenomenon: compulsion emphasized the internal origins of the phenomenon, constraint its immediate effect, and obsession described one of the most symptomatic consequences in the subject’s life.

For Freud the German term *Zwang* is one of a series of analogous terms like drive, urge, or thrust, used to signify that the mental forces governing the human mind must be treated in the same way as other natural forces, even though their origin and meaning are radically different. The word was used in medical research in Germany at the end of the nineteenth century, and was first defined by Karl Friedrich Westphal in 1877. At the time the term corresponded to the way in which members of the Berlin Group (1840–1846), represented by Hermann von Helmholtz, approached the investigation of mental phenomena, first subjecting them to rigorous scientific observation, as they would any other phenomenon.

The term appeared in 1894 when Freud addressed what he referred to as the “psychoneuroses of defense” in a discussion of obsessional representations, to differentiate them from hysterical or phobic manifestations. Freud explains that the compulsive representation results from a “poor connection,” whereby an affect arising from a repressed representation attaches itself to

another representation (1894a). As in hysteria the repressed representation is of a sexual origin, but the compulsive representation is completely dissociated from it. In the *Studies on Hysteria* (1895d), Freud speaks of a “compulsion to associate.” And on September 25, 1895, in his “Project for a Scientific Psychology” (1950a [1895]), he uses the term “compulsion” to refer to the impression produced by “hyperinvested representations” such as those that occur during hysteria, even referring to “hysterical obsession.” The occurrence of these representations produces effects “that it is impossible to suppress or understand,” the subject being completely aware of the strangeness of the situation. During this same period, he refers to compulsive affects (*Zwangsaffekte*). In a letter to Wilhelm Fliess dated December 6, 1896, the term “compulsion” characterizes the return of the memory of a satisfying sexual experience, regardless of the clinical presentation in question. Finally, it is compulsion that pushes all human beings toward incest (letter to Fliess dated October 15, 1897, and *An Outline of Psychoanalysis*, 1940a [1938]).

The concept followed two separate paths in its evolution. Faithful to his initial intentions, Freud pursued his investigation of compulsion in obsessional neurosis, especially in his analysis of the “Rat Man” (1909d). The most symptomatic compulsion of this patient was the “rat torture,” together with its obvious connotation of anal sadism. But the analysis revealed many others, such as the compulsion to protect his lady friend, “which can signify nothing other than a reaction to the contrary, and therefore hostile, tendency.” He also refers to “two-stage compulsive acts,” where the first is cancelled by the second, and points out the ambivalence. This simultaneity of internal compulsion and the struggle against what it entails is characteristic of compulsive neurosis and is what causes the unrelenting and exhausting struggle; it is this that led Pierre Janet to speak of “psychasthenia.”

Subsequently, Freud made compulsion a key element of his metapsychology. It refers to what is ineradicable and insurmountable in the drive, the thing that must always be confronted. If it weren’t for the possibility of change, this would not be unlike the idea of some inevitable destiny or hopeless determinism. For Freud, compulsion has the following characteristics: its dystonic quality with respect to the behavior or customary activities of the subject, the conviction of a disastrous outcome if it is not obeyed, and the promise of actual relief if it is allowed to proceed unrestricted.

The notion of compulsion was adopted by Freud's early disciples, especially Alfred Adler, who saw in it a reaction to a feeling of inferiority (1907). Melanie Klein attributes it to the activity of partial primary objects, as do Donald Winnicott and Wilfred Bion. Jacques Lacan considered compulsion an "object-cause of desire," which he formulated in terms of an "object *a*." For Jean Laplanche compulsion is the effect of "messages of enigmatic origin." These are accompanied by the progressive objectification of the foundations of the compulsion, and an increasingly greater effort at translating them into objects or representations.

Concepts that are similar to compulsion in the Freudian lexicon include pressure (*Drang*), introduced by Freud in 1915 in the *Metapsychology* (1915c), which is the equivalent for each drive of what compulsion is in the totality of mental life. Similarly, an urge is the irrepressible fulfillment of an act during a moment of paroxysm, whereas the compulsion implies an internal obstacle to its fulfillment.

The Freudian idea of a constant and insistent force associated with certain thoughts is not without its drawbacks. It does reflect the speech of certain patients, especially during obsessional neurosis or cases of mental automatism (Gaëtan de Clérambault). But by emphasizing the element shared by all forms of internal compulsion, as Freud does in the *Outline*, the concept is sometimes used to justify exclusively medicinal or behaviorist approaches to treatment. The initial Freudian idea is, however, quite different. It attempts to reestablish the relational conditions that give rise to compulsion, to restore it to the internal setting in which it first took shape.

GÉRARD BONNET

*See also:* Bulimia; Change; *Development of Psycho-Analysis*; Dipsomania; Excitation; Negative transference; Negative work of the; "Notes Upon a Case of Obsessinal Neurosis (Rat Man); Obsessional neurosis; Obsession; Pleasure/unpleasure principle; "Remembering Repeating and Working-Through"; Repetition compulsion; Resistance.

### **Bibliography**

- Adler, Alfred. (1974). La pulsion d'agression dans la vie et dans la névrose. *Revue française de psychanalyse*, 38 (2-3), 417-426. (Original work published 1908)
- Freud, Sigmund. (1894a). The neuro-psychoses of defence, *SE*, 3: 45-61.

### **Further Reading**

- Busch, Fred. (1989). The compulsion to repeat in action: a developmental perspective. *International Journal of Psychoanalysis*, 70, 535-544.
- Kubie, Lawrence S. (1939). A critical analysis of the concept of a repetition compulsion. *International Journal of Psychoanalysis*, 20, 390-402.
- Loewald, Hans W. (1971). Some considerations on repetition and repetition compulsion. *International Journal of Psychoanalysis*, 52, 59-66.

## **COMPULSIVE NEUROSIS.** *See* **Obsessional neurosis**

### **CONCEPT**

For Wilfred Bion, conception is the result of coupling a pre-conception, an innate a priori idea, and a realization, elements of the real that are provided by external-sensory or internal-emotional experience. The concept is derived from conception through abstraction and generalization. Language and the attribution of a name to a concept unite pre-conception and realization, preventing any loss of experience in the process. In Bion's grid conception appears in row E, below the pre-conceptions (row D). The transition from D to E occurs when a pre-conception (for example, the infant's innate expectation of the breast) encounters a negative realization (absence of the real breast).

In a key article on the theory of thought, presented during the International Congress of Psychoanalysis held in Edinburgh in 1961, Bion appears to contradict himself when discussing his theory of conceptions. In one paragraph he says that the union of the pre-conception (innate expectation of the breast) with the realization ("the breast itself") gives rise to a conception, associated with an experience of satisfaction. In the following paragraph he writes that it is only when the pre-conception is joined with frustration that a conception (thought) is produced.

There is a problem with Bion's first statement. For if there is no internal object because that object has not been thought, it is difficult to justify how the "breast itself" could make contact with the pre-conception. Bion's second statement leads us to believe that the sensation of hunger (emotion), combined with the frustration (absence of the breast), will create the conception of "no breast," a "non-object," which then, through

contact with the mother and the intervention of the container-contained mechanism, ♂♀, will be able to become a “good breast.” The presence of two innate pre-conceptions, present at the start of life: “bad” and “good” breasts, which are coupled with the realizations concerning the “absent breast” and the nourishing breast also need to be recognized. This will be the basis of the first internal object. Additionally, it is the infant’s constitution, which enables him or her to tolerate the frustration of hunger, of the “absent breast,” while preventing it from becoming prematurely the “bad breast” whose fate is then to be evacuated in the same way as feces, tears, et cetera (beta-elements).

Bion considers the concept a conception that has been assigned a name. The concept signifies a growth of the abstraction that enables us to expand the generalization of psychoanalytic theories, which, as a whole are judged to be too descriptive, too concrete. Concepts can be articulated in a deductive scientific system that functions like an *Ars combinatoria*.

PEDRO LUZES

*See also:* Grid; Breast, good/bad object; Preconception; Realization; Thought.

### **Bibliography**

Bion, Wilfred. (1962a). *Learning from experience*. London: Heinemann; New York: Basic Books.

———. (1967). A theory of thinking. In *Second thoughts*. London: Heinemann. (Reprinted from *International Journal of Psycho-Analysis*, 43, 4–5.)

———. (1963). *Elements of psycho-analysis*. London: Heinemann.

---

## **CONDEMNING JUDGMENT.** *See Judgment of condemnation*

---

## **CONDENSATION**

Condensation, along with displacement, is an essential process in dream work and more generally in primary-process thinking. We tend to view it as a way of attributing, to a person or representative object, characteristics and properties that, from the point of view of latent thoughts, belong to other persons or objects. In reality, if we go by Freud’s text in *The Interpretation of*

*Dreams* (1900a), condensation, like displacement, does not proceed directly by modifying the content of a representation. All dreams are made up of latent dream thoughts, each of which corresponds to one or several chains of associations, with each link being initially charged with a psychic intensity. Dream work consists in changing the location of these fragmentary intensities without either increasing or reducing their global value.

In displacement, one assigns to link *A* in a chain of associations the intensity initially associated with link *B*. Condensation, in contrast, operates by bringing intensities together. When two chains of association intersect, it assigns to the common link the sum of the intensities of the two intersecting chains. This nevertheless indirectly alters the representation because, in the manifest content of the dream, a link will not figure if it does not retain an intensity. By displacing the intensities of several chains to their common link, condensation makes it possible to represent all of the chains by a single link. Hence, there is an economy of means that contributes to censorship. As a result, when one link takes the place of several chains, this makes it more difficult to read through to the wish corresponding to those chains.

Condensation thus has an indirect effect on the figurative content of representations. It does not create chimeras that bring together in one element the attributes of others. Nor does it engage in metonymy, in which one of the links represents one or several chains of association. It is a process that operates by displacing intensity, but when the intensity of several chains is brought to bear on their common link, condensation seeks to represent them all.

When explaining the effect of condensation, Freud used the metaphor of italics. A representative link whose intensity has been reinforced by condensation has a status comparable to that of a word in italics in a text. This metaphor calls for two remarks. First, the intensity added to a fragment of a representation through condensation makes it possible, like italics, to stress the importance of the representation. This added intensity indicates at the manifest level that the representation stands for the different latent chains intersecting at the link. Second, typographical emphasis warps the texture of a text and invites us to look for links other than those offered by successive statements. Typographical emphasis is an invitation to abandon linearity and search for the dreamer’s associations.

The notion of intensity is complex. The term indicates the psychic interest of a particular idea. But we may well ask whether this interest should not be extended to the affect associated with each chain of associations or the instinct that determines each association.

Although Freud studied condensation particularly in relation to dreams, especially in *The Interpretation of Dreams*, he also describes the effect of this process in other manifestations of primary-process thinking, such as jokes, forgetting names, slips of the tongue, and symptoms. In these latter domains, however, it is sometimes quite difficult to distinguish between condensation and overdetermination. In both cases, as the result of a transformation, a representation substitutes for more elaborate thought content. Both processes seem to proceed by increasing intensity, that is, by economic modification, and this results in the reorganization of the thought content. But whereas condensation can be viewed as a sum of intensities relative to forces acting in the same direction, overdetermination appears more as an appropriation of content by heterogeneous if not antagonistic forces. In fact, the content of an overdetermined representation acts as a fulcrum for opposing logics and conflicting systems (such as the preconscious and the unconscious). A thought content (or representation) resulting from the interaction of forces pushing for the fulfillment of an unconscious wish and forces opposing it (the censor) is a good example of overdetermination but not of condensation, since the censor is not part of the latent dream thoughts. However, as soon as the signifying element begins to represent conflict (as in the case of a symptom), the difference between condensation and overdetermination is more difficult to establish.

LAURENT DANON-BOILEAU

*See also:* Dream; Dream work; Identification; Jokes; Metaphor; Primary process/secondary process; Representability; Slips of the tongue; Unconscious formations; Unconscious, the; Work (as a psychoanalytical notion).

### **Bibliography**

- Freud, Sigmund. (1900a). The interpretation of dreams. *SE*, 4: 1–338; 5: 339–625.
- . (1905c). Jokes and their relation to the unconscious. *SE*, 8: 1–236.
- . (1916–1917a [1915–17]). Introductory lectures on psycho-analysis. *SE*, 15: 9–239; 16: 243–463.

## **CONFLICT**

In psychoanalysis, the notion of conflict generally refers to intrapsychic conflict in which antagonistic forces are pitted against each other. The idea is central to psychoanalytic doctrine: It is no exaggeration to say that in light of the importance given to infantile sexuality and the unconscious, conflict is basic to the structuring of the psychic armature; further, it can be said that Sigmund Freud devoted his entire life to elaborating a theory of conflict.

Freud takes a cautious approach in his early work. He remains close to a psychology of consciousness at the beginning of his theory of repression, when he evokes, in the patient under the influence of a wish, the surging forth of “contrasting representations” and “irreconcilable ideas” that are so painful that, by an effort of “counter-will” the patient decides “to forget the thing” (1941b [1892], Notice III). From the outset, then, he posits the idea of a fundamental conflict between wishes and what opposes them. When Freud later unreservedly states that this process—repression—is essentially unconscious, that perspective, as much as the role of sexuality in wishes, becomes the basis for his parting of ways with Josef Breuer and for his ongoing opposition to such thinkers as Pierre Janet.

From that point on, it is possible to follow the stages in his elaboration of a general theory of conflict:

- as their name indicates, the neuropsychoses of defense (hysteria, obsessional neurosis, phobia) can be attributed to the conflict between wishes and obstacles to their fulfillment;
- this struggle is expressed in compromise formations in which the wish is blocked and, at the same time, finds fulfillment in disguised forms: This is the return of the repressed, in the form of symptoms, dreams, slips of the tongue, parapraxes, and so forth, and all these socially and morally acceptable substitutive formations nevertheless produce an occult satisfaction of desire, thus providing an outlet for accumulated psychic energy;
- it is thus important to distinguish manifest conflict, as it appears in the complaints of the patient and those around him or her, in symptomatology, and so on, from latent conflict, which only the work of psychoanalysis can bring to light;



- the source of conflict is always to be sought in psychosexuality. Such, at least, is the position that Freud vigorously affirms in the first part of his work. However, the status of aggression posed a problem and would remain a troublesome point<sup>44</sup> in his theory. He returned to the issue, without finding a satisfactory solution, with his second theory of the instincts and the introduction of the “death instinct,” in his attempt to find what might lie “Beyond the Pleasure Principle” (1920g) and by reframing questions related to sadism and masochism (for example, in “The Economic Problem of Masochism” [1924c]) and the like;
- the theorization of the neuropsychoses of defense explicitly posits the existence of psychopathological states that do not follow this schema in that they are not produced by a conflict between the instincts and the defenses: perversions (“the neuroses are the negative form of perversion,” Freud writes in “Three Essays on the Theory of Sexuality” [1905d, p. 238]) and actual neuroses, in which the symptom is produced by a direct flow of libidinal energy into the somatic functions, without passing through psychical working over (this latter category was taken up and extensively developed in modern studies of psychosomatic disorders). However, these distinctions, which seem to originate in a somewhat overly rigorous psychoanalytic nosography, were challenged by Freud’s successors;
- an important watershed occurred around 1910 with regard to two connected areas, when Freud began to envisage conflicts between the “two principles of mental functioning,” the pleasure principle and the reality principle (“Formulations on the Two Principles of Mental Functioning” [1911b]), and the opposition between narcissistic cathexes and object cathexes (“On Narcissism: An Introduction” [1914c]);
- at the same time, Freud’s theorization of the Oedipus complex (explicitly designated by that name for the first time in 1910, although the idea is present much earlier) brought to light the idea of conflicting identifications (first and foremost, between paternal and maternal identifications);
- from this point on, the stages in libidinal development having been established, different developmental and structural levels of psychic conflict can be distinguished. In the case of orality,

biting/not biting the breast; according to Karl Abraham, this ambivalent phase is preceded by a preambivalent phase. In the anal phase, expulsion/retention; this is where the sadistic/masochistic and active/passive oppositions are imbricated. The phallic phase is characterized by the oppositions between phallic/castrated and masculine/feminine as well as by the principal form of conflict that places desire in opposition to prohibition. As is clear from this brief summary, conflict in Freudian thought often takes the form of pairs of opposites.

There is more at issue here than merely situating conflicts in the activation of the erogenous zones. When there is conflict, it involves the putting into play of object relations (for example, in the case of anality, in the oppositions between satisfying/disappointing or giving/refusing). The love/hate opposition, which Melanie Klein posits as fundamental (working within the perspective inaugurated in Freud’s second theory of the instincts) has since undergone extensive elaboration. Finally, at the most basic level of all, the opposition between being/nonbeing should no doubt be added; its importance is apparent in the study of psychoses.

Conflict can pit the instincts themselves against one another. In his early work Freud places the sexual instinct in opposition to the instinct for self-preservation; in his second theory, he opposes the life instinct to the death instinct. Moreover, clinical practice suggests that instincts may be conflictual in themselves: It has been observed that in certain anxiety states instinctual satisfaction is fantasized as a cataclysmic explosion that would annihilate all the subject’s vital energy in a single instant and cause death. We should also recall the forms of conflict in which different agencies within the psychic apparatus are in opposition: the conscious and the unconscious in Freud’s early theory, or the Id, the Ego, and the Superego in his later work.

In all the above forms, conflict is considered in terms of its intrapsychic workings. However, it is clear we should also consider its articulation with interpersonal conflicts and, beyond that, the problem of conflicts between the individual and society, which Freud himself addressed several times, notably in *Group Psychology and Analysis of the Ego* (1921c) and *Civilization and Its Discontents* (1930a).

ROGER PERRON

See also: Allergy; Ambivalence; “Analysis Terminable and Interminable”; *Beyond the Pleasure Principle*; Compromise formation; Defense; Defense mechanisms; Doubt; Drive/instinct; Dualism; Dynamic point of view, the; Ego autonomy; Hysteria; Oedipus complex; Neutrality/Benevolent neutrality; Nuclear complex; Prohibition; Psychotic potential; Reaction-formation; Splitting; Symptom-formation; Transference hatred.

### **Bibliography**

- Freud, Sigmund. (1894a). The neuro-psychoses of defence. *SE*, 3: 45–61.
- . (1905d). Three essays on the theory of sexuality. *SE*, 7: 130–243.
- . (1911b). Formulations on the two principles of mental functioning. *SE*, 12: 218–226.
- . (1914c). On narcissism: an introduction. *SE*, 14: 67–102.
- . (1920g). Beyond the pleasure principle. *SE*, 18: 1–64.
- . (1921c). Group psychology and the analysis of the ego. *SE*, 18: 65–143.
- . (1924c). The economic problem of masochism. *SE*, 19: 155–170.
- . (1930a). Civilization and its discontents, *SE*, 21: 57–145.
- . (1941b [1892]). Sketches for the ‘Preliminary communication’ of 1893, (B) ‘III.’ *SE*, 1: 149–150.

### **Further Reading**

- Brenner, Charles. (1982). *The mind in conflict*. New York: International Universities Press.
- Frank, George. (1996). Conflict and deficit: two theories or one? *Psychoanalytical Psychology*, 13, 567–570.
- Smith, Henry. (2003). Conceptions of conflict in psychoanalytic theory and practice. *Psychoanalytic Quarterly*, 72, 49–96.

## **CONFRONTATION**

The seminar known as *Confrontation*, designed to foster discussion and overcome intellectual isolation engendered by institutional divisions in French psychoanalysis, was created by René Major and Dominique Geahchan in 1973. It represented an effort to develop a non-sectarian forum for discussion and debate among analysts and to bring psychoanalysis into contact with related disciplines.

At the time, four psychoanalytic institutions were operating in France. The Société Psychanalytique de Paris (SPP) and training institute was the first to be founded and the progenitor of the others; there was also the Association Psychanalytique de France (APF). Members of that organization helped Jacques Lacan to establish the École Freudienne de Paris in 1964 while a schism in that group had led five years later to the founding of what was known as the Quatrième Groupe. The various splits had precipitated considerable resentment amongst French analysts, especially after the International Psychoanalytic Association (IPA) pointedly refused to recognize Lacan or Françoise Dolto as training analysts. The resulting climate of divisiveness favored dogmatism.

Major and Geahchan belonged to the Paris society; the former was director of the training institute. Attendees at the first seminar brought Wladimir Granoff, Serge Leclair, and François Perrier before institute members, including Nicolas Abraham, Denise Braunschweig, Alain de Mijolla, Jacques Mynard, Michel Neyraud, Catherine Parat, Maria Torok, Serge Viderman; analysts from the three other groups also attended. Subsequent meetings took place at the Maison de la Chimie and at the Maison des Polytechniciens.

Thus there developed an extensive exchange of ideas, after years of relative isolation, among analysts such as Piera Aulagnier, Jean Clavreul, Jean Laplanche, Maud and Octave Mannoni, Michèle Montrelay, Jean-Bertrand Pontalis, Elisabeth Roudinesco, François Roustang, Moustapha Safouan, Conrad Stein, and Nathalie Zaltzman. Dialogue also took the form of meetings with philosophers, mathematicians, historians, and linguists—among them Jean Baudrillard, Catherine Clément, Jacques Derrida, Serge Doubrovsky, Luce Irigaray, Sarah Kofman, Philippe Lacoue-Labarthe, Jean Claude Milner, Jean-Luc Nancy, and Jean Petitot.

By 1975 these seminars became a site of intellectual exchange that considered psychoanalysis in relation to literature, politics, law, and religions through investigations of little-studied themes. Well-known analysts attended these meetings, regardless of their institutional affiliation, in an atmosphere of openness that encouraged debate on the merits of the various idioms that were then developing what might be more broadly construed as the language of psychoanalysis. The seminars also led to various publications under the imprints of Éditions Confrontation and Éditions Aubier Montaigne.

Memorable seminars included one that, for the first time in France, brought to light the situation of psychoanalysis in Argentina and Brazil during a period of dictatorship and human rights abuse. Another concerned *The Post Card*, re-igniting the dispute initiated by Lacan’s “Seminar on ‘The Purloined Letter’” and Derrida’s interpretation of it. An Anglo-French meeting debated the relationship of psychoanalysis and deconstructionism, analytic philosophy, and feminism; it brought together Hélène Cixous, Jacques Derrida, Antoinette Fouque, Serge Leclair, and Juliet Mitchell. Another seminar, in Italy with Armando Bauleo, concerned politics and society.

Neither an institute nor training program vis-à-vis clinical practice, the *Confrontation* seminars realized in embryonic form Freud’s hope, expressed in *The Question of Lay Analysis*, for new post-graduate institutions that would enable analysts to acquire a broader base of knowledge for understanding science and culture. The seminars ended in May 1983, with the death of Dominique Geahchan.

In a larger context, *Confrontation* was a first step toward a broader forum for analytic thought outside of conventional institutes. At the Collège International de Philosophie, René Major directed a colloquium on “Lacan and the Philosophers” in 1990. In 1997, after a similar meeting held upon publication of Helena Besserman Vianna’s book on Brazil, Major called for an international conference. This became the first Estates General of Psychoanalysis, held at the Sorbonne in the year 2000, with representative from thirty-three countries and the ultimate aim of creating a European-based institute of advanced studies in psychoanalysis.

CHANTAL TALAGRAND

See also: *Cahiers Confrontation, Les*.

### **Bibliography**

Major, René. (1991). *Lacan avec Derrida*. Paris: Éditions Menta.

Besserman Vianna, Helena. (1995). *N’en parlez à personne. La psychanalyse face à la dictature et à la torture*. Paris: Éditions l’Harmattan.

Collège International de Philosophie. (1991). *Lacan avec les philosophes*. Paris: Editions Albin Michel.

---

## **“CONFUSION OF TONGUES BETWEEN ADULTS AND THE CHILD”**

Sándor Ferenczi’s original title for this article, prepared for the Wiesbaden Congress (September, 1932) was “The Passions of Adults and their Influence on the Development of the Character and the Sexuality of the Child.”

The change in the name of the article is indicative of Ferenczi’s new perception of the problem of traumatism; for the first time he established a clear distinction between the language and motivation (desire for tenderness, security, basic love, “passive object-love”) of childhood and the reasons for passionate language in some adults, when they are seducers, desirous of genital excitation and a domination through violence. Recalling the central Freudian thesis of the *Three Essays on the Theory of Sexuality* (1905d), Ferenczi expounded most eloquently in this text the notion of the hypnotizing and the terrorizing effects of suffering, which, because they are passionate punishments coming from the adult, allow the child to feel even more attached to that person: “The same anxiety, however, if it reaches a certain maximum, compels them to subordinate themselves like automata to the will of the aggressor, to divine each one of his desires and to gratify these; completely oblivious of themselves they identify themselves with the aggressor. Through the identification, or let us say, introjection of the aggressor, he disappears as part of the external reality, and becomes intra- instead of extra-psyche” (1932/1955, p. 162).

This is how Ferenczi describes the introjection of the adult’s guilt by children, followed by confusion, loss of confidence in their own perceptions, and fragmentation of the personality, particularly devastating when the traumatic shock has been incestuous. In this text he created his daunting metaphor for post-traumatic precocious maturity: “The precocious maturity of the fruit that was injured by a bird or insect” (p. 165).

The conclusions he came to on the basis of this pathological model had a bearing also on the practice of analysis; while they were not very well received at the time, some have turned out to be quite pertinent. A good number of these notions, articulated in his *Clinical Journal*, have influenced other prominent psychoanalysts, including Sacha Nacht in France; Michael Balint, his student and friend, in Great Britain; and Harold Searles and his students, Elizabeth Severn,

Clara Thompson, Sándor Lorand, and Sándor Radó, in the United States.

PIERRE SABOURIN

*See also:* Childhood; Ferenczi, Sándor; General theory of seduction; *Neurotica*; Passion; Primal fantasies; Psychic causality; Real trauma; Relaxation principle and neo-catharsis; Seduction scenes; Seduction; Sexual trauma; Tenderness; Trauma.

### Source Citation

Ferenczi, Sándor. (1955). Confusion of tongues between adults and the child. In *Final contributions to the problems and methods of psychoanalysis* (, p. 156–67). London, Hogarth Press. (Original work published 1932).

### Bibliography

- Freud, Sigmund. (1905d). Three essays on the theory of sexuality. *SE*, 7: 123–243.
- Sabourin, Pierre. (1982). Préface. In Sándor Ferenczi, *Oeuvres complètes* (Vol. 4). Paris: Payot.

## CONGRÈS DES PSYCHANALYSTES DE LANGUE FRANÇAISE DES PAYS ROMANS

On July 19, 1926, Freud mailed René Laforgue a little card announcing the first in a series of meetings. It read, “Dear Master, Gathered together on the occasion of the Geneva psychiatric congress, the members of our little Paris group and our Swiss friends send you our best wishes. The beautiful countryside allows us to rest from complicated discussions concerning schizophrenia, the superego, and the id.” Signatures: René Laforgue, Dr Robin, Mme Laforgue, Raymond de Saussure, Angélo Hesnard, Ariane de Saussure, Édouard Pichon, Adrien Borel. These meetings are still held regularly today; only their name has changed over the years.

The Congrès des psychanalystes de langue française des pays romans (Congress of Psychiatrists and Neurologists of France and French-Speaking Countries [also called “Congress of Alienists and Neurologists of France and French-Speaking Countries”]) was held in Geneva from August 2 to 7, 1926. The congress was organized around a paper by Henri Claude, “Dementia praecox and Schizophrenia.” Claude’s students came to listen to their “leader.” In this very psychiatric atmosphere, without anyone being aware of the preparations for the innovation, Claude’s followers, by associating with their Swiss colleagues—then more enthusiastic than the

French about psychoanalysis—held the first Conference of French-Speaking Psychoanalysts on Sunday, August 1, 1926. They also founded the Linguistic Commission for the Unification of French Psychoanalytic Vocabulary. In the morning session, presided over by Raymond de Saussure (of Geneva), René Laforgue (of Paris) presented a paper titled “Schizophrénie et schizonoïa” (Schizophrenia and schizonoïa; 1926). The afternoon session, presided over by A. Hesnard, was devoted to a paper by Charles Odier (of Geneva) titled “Contribution à l’étude du surmoi et du phénomène moral” (A contribution to the study of the superego and the phenomenon of morality; 1927).

Édouard Pichon, the new secretary, stated, “It has been decided to hold the conference every year in the same city as the Congress of Psychiatrists and on the eve of the opening of that congress.” This plan was followed for the second conference, held in Blois, France, on July 27, 1927. The conference focused on Charles Odier’s paper “La névrose obsessionnelle” (Obsessional neurosis; 1927). And it opened up to physicians other than psychiatrists. The third meeting, now separate from the Congress of Psychiatrists, was held in Paris in July 1928 on the subject of “psychoanalytic technique.” Thereafter, conferences were held in the amphitheater of the mental health clinic of Saint-Anne’s Hospital, thus facilitating a mandatory show of reverence for the resident master Henri Claude.

In the conference two cliques formed. On one side were the “orthodox” Freudians, grouped around Marie Bonaparte and including Eugénie Sokolnicka, Rudolph Loewenstein, and two Swiss members, Raymond de Saussure and Charles Odier. On the other side were the partisans of a “French psychoanalysis,” associated with the medical and institutional hierarchy. They had Édouard Pichon as their bellicose herald, along with Angélo Hesnard, René Allendy, Georges Parcheminey, Henri Codet, and later René Laforgue.

One of the themes of the latter group was a distinction between a suspect psychoanalytic doctrine and a method whose success was undeniable but whose mode of application needed to be adapted to French sensitivities. An example of this distinction is President René Allendy’s address on the occasion of the sixth Conference of French-Speaking Psychoanalysts on October 30, 1931: “Psychoanalysis is not just some kind of a theory. It has a more precious and less debatable claim to fame: it has cured morbid states that hitherto resisted all therapeutic treatments.” As a result

of the distinction, later meetings saw the presentation of two distinct papers, one theoretical and one clinical. This dichotomy was maintained until 1960, when, on the occasion of the twenty-first Congress of Romance-Language Psychoanalysts in Rome, the congress bureau, encouraged by a suggestion from Nicola Perotti, decided to abolish the distinction.

The success of the conference and an abundance of contributions on the subject of “conversion hysteria” (including those by Georges Parcheminey and Blanche Jouve-Reverchon) led in 1931 to the sixth conference being held, for the first time, over a two-day period. It was also the first conference to receive a good-will telegram from Max Eitingon, president of the International Psychoanalytical Association (IPA). This custom was regularly maintained by Ernest Jones and continued after the war until it was replaced in 1974, during the presidency of Serge Lebovici, by a representative of the IPA attending the conferences.

The eighth conference, on “genetic psychology and psychoanalysis,” brought Jean Piaget and Raymond de Saussure face to face in December 1933. Among the speakers we find, for the first time, the name of then thirty-two-year-old Jacques Lacan. There were no conferences in 1932 and 1934, but two were held in 1933. There followed the mystery of two “ninth” conferences, this figure being applied both to the conference held in Paris on February 2, 1935, on Paul Schiff’s paper “Les paranoïas et la psychanalyse” (Paranoia and psychoanalysis; 1935), and to the conference held in Nyons on April 10 and 11, 1936.

The tenth conference, in reality the eleventh, was held in Paris on February 21 and 22, 1938. Sacha Nacht delivered a paper titled “Le masochisme: étude historique, clinique, psychogénique et thérapeutique” (Masochism: an historical, clinical, psychogenetic, prophylactic, and therapeutic study; 1938). Rudolph Loewenstein, speaking on “L’origine du masochisme et la théorie des pulsions” (The origin of masochism and the theory of the instincts; 1938), opposed his former analyst on the notion of a death instinct, which Nacht rejected. This was the last conference of French-speaking psychoanalysts before the Second World War.

The conferences, which were just as political as they were theoretical or clinical, were not held for the duration of the war. Their resumption after ten years marked the renewal of psychoanalysis in both France and Europe. This eleventh conference, held in Brussels between

May 14 and 17, 1948, was organized around Sacha Nacht’s paper “Les manifestations cliniques de l’agressivité et leur rôle dans le traitement psychanalytique” (Clinical manifestations of aggression and their role in psycho-analytic treatment; 1948) and Jacques Lacan’s paper “L’agressivité en psychanalyse” (Aggression in psychoanalysis; 1948). The following year, at the twelfth conference held in Paris, John Leuba and H. G. Van des Walls dealt with narcissism. This conference was distinguished most of all by the presence of Melanie Klein, who, however, failed to make converts among French psychoanalysts. Relations with neighboring countries improved, and on October 16, 1951, the conference changed its name to the Conference of Romance-Language Psychoanalysts, an extension attributed to Jacques Lacan. The conference thus made official its increasingly close collaboration with Belgian, Spanish, Italian, and Swiss societies of psychoanalysis.

In 1953 a sixteenth special conference was held in Rome. The division of the Société psychanalytique de Paris (Paris Psychoanalytic Society) (SPP) in June divided the conference into two parts. In one, the members of the society listened to Emilio Servadio, Francis Pasche, René Spitz (who came from New York), Serge Lebovici, and René Diatkine. They then departed, and members of the new Société française de psychanalyse (French Society of Psychoanalysis) entered to listen to Jacques Lacan’s paper “Fonction et champ de la parole et du langage en psychanalyse” (The function and field of language in psychoanalysis). Jealously simmering in the Paris Psychoanalytic Society tore the two rival societies apart for more than a decade, and the following conferences of French-speaking psychoanalysts fit into the general strategy of the two societies’ struggle for influence.

Yet the conferences were also the scene of original theoretical elaborations marking the evolution and deepening of the psychoanalytic thinking of members of the Paris Psychoanalytic Society. This can be seen from a sample of papers presented at the conferences: Sacha Nacht and Serge Lebovici, “Indications et contre-indications de la psychanalyse chez l’adulte” (Indications and contraindications for psychoanalysis for adults; 1954); René Diatkine and Jean Favreau, “Le caractère névrotique” (The neurotic character; 1956); Francis Pasche, “Le génie de Freud” (The genius of Freud; 1957); Béla Grunberger, “Essai sur la situation analytique et le processus de guérison” (The analytic situation and the process of healing; 1956); Sacha Nacht and Paul-Claude

Racamier, "La théorie psychanalytique du délire" (The psychoanalytic theory of delusions; 1958); Maurice Bouvet, "Dépersonnalisation et relations d'objet" (Depersonalization and object relations; 1960); P. Bofill and P. Folch-Mateu, "Problèmes cliniques et techniques du contre-transfert" (Clinical and technical problems with counter-transference; 1963); Michel Fain and Christian David, "Aspects fonctionnels de la vie onirique" (Functional aspects of dream life; 1962); Angel Garma, "L'intégration psychosomatique dans le traitement psychanalytique des maladies organiques" (Psychosomatic integration in the psychoanalytic treatment of organic illnesses); Michel Gressot, "Psychanalyse et psychothérapie: leur commensalisme" (Psychoanalysis and psychotherapy: their compatibility; 1963); René Held, "Rapport clinique sur les psychothérapies d'inspiration psychanalytique freudienne" (Clinical report on psychotherapies inspired by Freudian psychoanalysis; 1963); Franco Fornari, "La psychanalyse de la guerre" (The psychoanalysis of war; 1964); Evelyne Kestemberg and Jean Kestemberg, "Contribution à la perspective génétique en psychanalyse" (Contribution to the genetic perspective in psychoanalysis; 1965); Rudolph Loewenstein, "Rapports sur la psychologie psychanalytique de H. Hartman, E. Kris, et Rudolf Loewenstein" (Report on the psychoanalytic psychology of H. Hartmann, E. Kris and Rudolf Loewenstein; 1965); Olivier Flournoy, "Du symptôme au discours" (From symptom to discourse; 1967); André Green, "L'affect" (The affects; 1970); and to end this list, Didier Anzieu (of the Association psychanalytique de France [French Psychoanalytic Association]), the first such contributor since the split in 1953), "Éléments d'une théorie de l'interprétation" (Elements of a theory of interpretation; 1970).

In 1955 the conferences became known as congresses. In 1956 Pierre Luquet was appointed permanent secretary for the congresses, a position he occupied for thirty-three years until 1989, when he was replaced by Augustin Jeanneau, assisted by Pearl Lombard. He handled the arrival and departure of societies from neighboring countries, administrative matters concerning their participation, relations with the French Psychoanalytic Association, and relations with the European Federation for Psychoanalysis, created in 1966. In addition, he negotiated publication of the first large annual volumes of congress proceedings.

The locale of the congresses alternated between Paris and a neighboring country. This international character is reflected in its changes of name to Congress of

French-Speaking psychoanalysts from Romance-language countries and then to French-speaking psychoanalysts. The days of didactic reports gave way to much more audacious presentations of clinical and theoretical research, as shown by the few examples mentioned. Moreover, the choice of subjects and contributors traces the history of psychoanalysis in France, including the tensions and alliances that characterized the division of the French psychoanalytic movement in relation to the International Psychoanalytical Association.

ALAIN DE MIJOLLA

See also: Belgium; France; *Revue française de psychanalyse*; Société psychanalytique de Paris and Institut de psychanalyse de Paris.

### **Bibliography**

Mijolla, Alain de. (1991). Le congrès des psychanalystes de langue française des pays romans: quelques éléments d'histoire. *Revue française de psychanalyse*, 55 (1), 7–36.

---

## **CONGRÈS INTERNATIONAL DE L'HYPNOTISME EXPÉRIMENTAL ET SCIENTIFIQUE, PREMIER**

Organized by Doctor Edgar Bérillon, founder and director of the *Revue de l'hypnotisme*, the Premier congrès international de l'hypnotisme expérimental et scientifique (First international congress on scientific and experimental hypnotism) was held at the city hospital in Paris on August 12, 1889, and chaired by Doctor Victor Dumontpallier. The discussions were heated, especially between those who maintained the existence of a link between hypnosis and hysteria (École de la Salpêtrière) and those who saw it as a form of suggestion that could be therapeutically useful (École de Nancy). There were further disagreements between Gilles de la Tourette (École de la Salpêtrière), who felt the power of suggestion of the hypnotist presented no danger to society, since the patient would resist any orders that challenged his morality, and the lawyer Jules Liégeois, who feared the consequences of such behavior. Additionally, some participants felt that hypnosis in public should be banned and hypnosis placed under medical supervision (Ladame, de Genève), and those who held a more liberal position (Joseph Delboeuf, de Liège), who believed that hypnosis should be practiced freely, although responsibly,

further claiming that a medical degree was not alone sufficient (given the level of medical education at the time) to ensure competence in the area of hypnosis.

The proceedings of the congress were sent to all active members. These included “Dr. Sigmund Freud, doctor, Vienna.” Early in his career Freud made use of hypnotic suggestion. He spent several weeks in Nancy to perfect his technique with Ambroise Auguste Liebeault and Hippolyte Bernheim. Freud left directly from Nancy to attend two congresses in Paris—the first on physiological psychology (August 5–10), the second on hypnotism (August 8–12). If it is true, as Ernest Jones noted, that Freud left Paris the evening of August 9, he could not have been present for the controversy between Ladame and Delboeuf during the second congress. Although he may have not been present for the discussions, he would have been able to read the various presentations in the published proceedings.

FRANÇOIS DUYCKAERTS

See also: Bernheim, Hippolyte; Delboeuf, Joseph Rémi Léopold; Hypnosis.

### **Bibliography**

- Bérillon, Edgar. (1889). *Premier Congrès international de l'hypnotisme expérimental et thérapeutique*. Paris: Doin.
- Duyckaerts, François. (1990). Delbœuf-Ladame: un conflit paradigmatique. *Revue internationale d'histoire de la psychanalyse*, 3, 25–37.
- Freud, Sigmund. (1925d [1924]). An autobiographical study. *SE*, 20: 3–70.
- Jones, Ernest. (1953). *Sigmund Freud: Life and work*. London: Hogarth Press.

## **CONSCIOUS PROCESSES**

Conscious processes comprise all phenomena, organized in time, linked to the individual's intuitive and immediate knowledge of his own mental life.

If, as Freud stressed, “in the  $\Psi$ -systems memory and the quality that characterizes consciousness are mutually exclusive” (1900a, p. 540), consciousness is thus indissolubly linked to perception and to the qualitative changes brought about by the *Pcs.-Cs.* system, on the one hand with respect to the outside world, by means of the sense organs, and on the other with

respect to the most superficial as to the deepest layers of the psyche. This system responds to the perception of pleasure and unpleasure, releases of which thus “automatically regulate”—at all levels, including the conscious one—“the course of cathectic processes” (p. 574). “But it is quite possible that consciousness of these [perceived] qualities may introduce in addition a second and more discriminating regulation, which is even able to oppose the former one, and which perfects the efficiency of the apparatus by enabling it, in contradiction to its original plan, to cathect and work over even what is associated with the release of unpleasure” (p. 616). “Thought-processes are in themselves without quality, except for the pleasurable and unpleasurable excitations which accompany them, and which, in view of their possible disturbing effect upon thinking, must be kept within bounds. In order that thought-processes may acquire quality, they are associated in human beings with verbal memories, whose residues of quality are sufficient to draw the attention of consciousness to them and to endow the process of thinking with a new cathexis from consciousness” (p. 617).

By virtue of the qualities thus acquired by the *Pcs.* system, now governed by secondary processes, “consciousness, which had hitherto been a sense organ for perceptions alone, also became a sense organ for a portion of our thought-processes” (p. 574), whereas feelings for their part pass directly from the unconscious into consciousness. Hence it is thanks to the mediation of word-presentations that “internal thought-processes are made into perceptions,” which is to say that they “are *actually* perceived—as if they came from without—and are consequently held to be true” (1923b, p. 23).

Such a hypercathexis of thought, which enables it to pass into consciousness, should be seen as analogous to what occurs at the level of the perception of the outside world thanks to the part played by attention, which Freud is just as insistent upon, and which is reinforced by the function of the *Cs.* system's protective shield against stimuli (1920g, p. 28). Whereas the sense organs process only a minimal proportion of external stimuli, “cathectic innervations are sent out and withdrawn in rapid periodic impulses from within into the completely pervious system *Pcpt.-Cs.*... It is as though the unconscious stretches out feelers, through the medium of the system *Pcpt.-Cs.*, towards the external world and hastily withdraws them as soon as they have sampled the excitations coming from

it”—a process that in Freud’s view “lies at the bottom of the origin of the concept of time” (1925a, p. 231).

A subtle dialectic may be observed here between the pleasure principle and the reality principle, a dialectic that facilitates the gradual institution and development of the functions of consciousness—attention, judgment, memory, and thought—in parallel with the shift from free energy to bound energy.

Over and above spontaneous conscious processes, it behooves psychoanalysis to offer an account of the processes involved in the passage into the conscious that occurs during treatment, among them displacement; the mastery of excitation; the transference of the analysand’s internal objects onto the analyst (for later return to the former); the transformation of unconscious traces into ideational representations; and working-through, meaning the transition from the spontaneous work of the psyche to an uninterrupted working-out activity, during the treatment, within and by means of the *Pcpt.-Cs.* system. Upon all of this is predicated the possibility of the past being effectively transformed into memory, and repetition into meaning; it is worth noting, however, that today the main concern would seem to be less the acknowledgment of transferred content than the work of transformation itself.

RAYMOND CAHN

*See also:* Consciousness; Introspection; Preconscious, the; Process; Signifier/signified.

### **Bibliography**

- Freud, Sigmund. (1900a). The interpretation of dreams. *SE*, 4  
 ———. (1920g). Beyond the pleasure principle. *SE*, 18: 1–64.  
 ———. (1923b). The ego and the id. *SE*, 19: 1–66.  
 ———. (1925a [1924]). A note upon the “Mystic Writing-Pad.” *SE*, 19: 225–232.

## **CONSCIOUSNESS**

In psychology, consciousness is the subject’s immediate apprehension of mental activity. Although Freud thought that conscious processes are “the same as the consciousness of the philosophers and of everyday opinion” and “a fact without parallel, which defies all explanation or description” (1940a [1938], pp. 159, 157), he argued that they could not be considered the

“essence” of mental life. Rather, consciousness has a fugitive quality and does not “form unbroken sequences which are complete in themselves” (p. 157). “The psychical, whatever its nature may be, is in itself unconscious and probably similar in kind to all the other natural processes of which we have obtained knowledge” (1940b [1938], p. 283). Freud stressed, however, that consciousness still plays an importance role; indeed, it is “the one light which illuminates our path and leads us through the darkness of mental life” (p. 286).

The work of psychoanalysis, as Freud saw it, is “translating unconscious processes into conscious ones, and thus filling in the gaps in conscious perception” (p. 286). Consciousness is the qualitative perception of information arising both from the external world and from the internal world: an external world that is unknowable in itself and to which we have access only via subjective elements collected by our sense organs and an internal world that consists of unconscious mental processes and that we are aware of solely through sensations of pleasure/unpleasure and revived memories. According to Freud, “A person’s own body, and above all its surface, is a place from which both external and internal perceptions may spring” (1923b, p. 25).

From the beginning Freud treated consciousness and perception as indissolubly linked, indeed, so much so that throughout his work he deemed them to constitute a single structure, the perception-consciousness system. Freud also drew a distinction, within nonconscious phenomena, between latent states susceptible of becoming conscious at any moment and repressed psychic processes inaccessible to consciousness. This led him to differentiate the unconscious system proper from a preconscious system, cut off from consciousness by censorship but also controlling access to consciousness. In this sense, the preconscious and the conscious are very close: both are governed by secondary processes and both draw on a bound form of psychic energy. In *The Interpretation of Dreams* (1900a), Freud spoke of the preconscious-conscious system, and in “The Unconscious” (1915e), he described the preconscious as “conscious knowledge” (p. 167), even though it provides access to unconscious contents and processes, provided that they have been transformed.



From his earliest writings on, Freud saw the link between consciousness and the ego as very close. And although by 1920 Freud viewed the ego as in large part unconscious in its defensive activities, he continued to attach consciousness to it as both the “nucleus” and the “surface of the mental apparatus” (1923b, p. 19).

By the early twenty-first century, the problem of perception had become increasingly complex. Freud’s near conflation of perception and consciousness, which required him to postulate that perceptual phenomena and the laying down of memory traces are incompatible, has come in for serious reconsideration. It is worth noting, though, that Freud himself, in his last years, was given pause on this issue by the problem of fetishism, apropos of which it was apparent that perceptions and mnemonic traces could be caught up in one and the same conflict. This line of thinking has led to a reevaluation of all psychopathologies where disavowal and splitting predominate, such as borderline conditions, and more generally, to a review of all states involving the relationship between perception and hallucination (see Donald W. Winnicott’s notions of the subjective object and of transitionality [1953]).

RAYMOND CAHN

*See also:* Agency; Censorship; Conscious processes; Ego; Metapsychology; Mnemic trace/memory trace; “Note upon the ‘Mystic Writing Pad,’ A”; Perception-consciousness (Pcpt.-Cs.); Preconscious, the; Psychic apparatus; Psychoanalytic treatment; Topographical point of view; “Unconscious, The.”

### **Bibliography**

- Freud, Sigmund. (1900a). The interpretation of dreams. *SE*, 4–5.
- . (1915e). The unconscious. *SE*, 14: 166–204.
- . (1923b). The ego and the id. *SE*, 19: 12–59.
- . (1940a [1938]). An outline of psychoanalysis. *SE*, 23: 139–207.
- . (1940b [1938]). Some elementary lessons in psycho-analysis. *SE*, 23: 279–286.
- Winnicott, Donald W. (1953). Transitional objects and transitional phenomena: A study of the first not-me possession. *International Journal of Psycho-Analysis*, 34, 89–97.

---

**CONSTANCY.** *See* Principle of constancy

---

### **CONSTITUTION**

Constitution is all the characteristics and tendencies, both somatic and psychic, that an individual brings into life at the time of birth. It is those parts of the individual that are innate, inherited, or genetically determined. Classically, it stands in opposition to all that is accidental, things acquired in the course of life. Certain doctrinal trends in the field of psychopathology rely on the notion of constitution in order to define personality types that are predisposed to specific psychiatric affections, particularly psychosis.

The notion of a constitutional factor is Freud’s, and he elaborated the theory in two distinct periods. Before 1905, he conflated it with hereditary disposition, referring to a general and universal condition in the pathogenic determinism of all affections, particularly neurotic affections. In the etiology of these affections, the hereditary disposition is associated with specific causes of a sexual nature in accordance with the rules of a complementary series. Thus, “the same specific causes acting on a healthy individual produce no manifest pathological effect, whereas in a predisposed person their action causes the neurosis to come to light, whose development will be proportionate in intensity and extent to the degree of the hereditary precondition” (1896a, p. 147).

After 1905, the Freudian conception of constitution became inseparable from the sexual doctrine resulting from his identification of infantile sexuality in all human beings. In *Three Essays on the Theory of Sexuality* (1905d), Freud traces the origin of infantile sexuality to component instincts that are perverse because they seek satisfaction independently of each other and thus define, for all individuals, a “polymorphously perverse disposition” (1905d, p. 191). “The conclusion now presents itself to us that there is indeed something innate lying behind the perversions but that it is something innate in *everyone*, though as a disposition it may vary in its intensity and may be increased by the influences of actual life” (1905d, p. 171). Sexual constitution thus came to replace general hereditary disposition.

In lecture twenty-three of *Introductory Lectures on Psychoanalysis* (1916–17a), entitled “The Paths to the Formation of Symptoms,” Freud enriched the notion of sexual constitution with that of fixation of the libido. These fixations represent the individual’s constitutional past toward which the libido regresses as a result of the repression imposed on it by the neurosis. According to Freud, these fixations are partly the traces of the phylogenetic heritage.

CLAUDE SMADJA

*See also:* Bisexuality; Character; Heredity of acquired characters; “Heredity and the Etiology of the Neuroses”; Instinct; Intergenerational; Phylogenesis; Prehistory; Primal fantasies; *Three Essays on the Theory of Sexuality*.

### **Bibliography**

Freud, Sigmund. (1896a). Heredity and the aetiology of the neuroses. *SE*, 3: 141–156.

———. (1905d). Three essays on the theory of sexuality. *SE*, 7: 123–243.

———. (1906a). My views on the part played by sexuality in the aetiology of the neuroses. *SE*, 7: 269–279.

———. (1916–17a). Introductory lectures on psychoanalysis. Parts I & II. *SE*, 15–16.

---

**CONSTRAINT.** *See* Obsessional neurosis

---

## **CONSTRUCTION DE L'ESPACE ANALYTIQUE (LA-) [CONSTRUCTING THE ANALYTICAL SPACE]**

This work has had and continues to have great importance for French psychoanalysis. It sheds an original light on a central question in Freud’s work, that of constructions in analysis.

Serge Viderman proposes to extend this notion very broadly and make it the basis of a metapsychological line of thought. He draws a distinction between the certainties we may derive from reconstructing a past

lost to repression and the uncertainty that must always attend constructions of the original nucleus. But he adds that “any thoroughgoing interpretation does not reconstruct the subject’s history, rather, it invents a story” (p. 27).

Much more than a discovery or a recovery, what is involved here is conjecture: to reconstruct a history is in fact to construct it. A metaphor nevertheless illustrates moments of certainty that occur in analysis: “Imagine two lighthouses turning in opposite directions with their beams crossing periodically. It is when transference and counter-transference intersect that the moments of greatest brilliance occur. Privileged moments when the truth of interpretation shines through” (p. 52).

Viderman keeps his distance from his contemporary Jacques Lacan, specifically writing: “The unconscious is structured as a language only because language structures it,” as well as from certain psychoanalytical clichés, especially “listening with the third ear.” In a sense, Viderman’s theory is built on the whole question of historical reality in analysis, a debate that began in 1897 when Freud declared that he no longer believed in his *neurotica*. For Viderman, “the historic illusion of psychoanalysis is still the trauma theory—*fons* and *origo* of pathogenesis—an infantile disorder of psychoanalysis that we may never have recovered from” (1970). Starting from the analysis of the counter-transference, he centers his theoretical approach to the analytic treatment on the analyst’s ability to construct—or rather to invent, based on what he hears, and on what he knows about analysis from his own analytic experience and theoretical knowledge.

The work of analysis, as he presents it, consists in trying to link the unknowable aspect of the instinct with the idea that denotes the instinct, an idea that, in turn, suffers the effect of interpretation, of what the analyst says about it. Viderman’s book closes with this thought: “Hegel had a presentiment that we would have to fabricate truth” (p. 344).

SOPHIE DE MIJOLLA-MELLOR

*See also:* Construction-reconstruction; “Constructions in Analysis” “From the History of an Infantile Neurosis (Wolf Man)”; Historical truth; History and psychoanalysis; Memories; Memory; Primal scene; Viderman, Serge.

**Source Citation**

Viderman, Serge. (1970). *La construction de l'espace analytique*. Paris: Denoël.

**Bibliography**

*Revue française de psychanalyse*. (March–June 1974). Constructions et reconstructions. À propos de *La construction de l'espace analytique*. 38, (2–3).

**Further Reading**

Casement, Patrick. (1990). *Further learning from the patient. The analytic space and process*. London/New York: Tavistock/Routledge.

Poland, Warren S. (1992). From analytic surface to analytic space. *Journal of the American Psychoanalytic Association*, 40, 381–404.

**CONSTRUCTION/RECONSTRUCTION**

Constructions are conjectures that the analyst couches in the form of stories concerning a part of the analysand's childhood history and bases on previous partial interpretations. A construction is meant to compensate for absent or insufficient memory, but it may itself stimulate recollection.

Freud spoke of construction in connection with the "Rat Man" (1909d) and, more specifically, in connection with the Rat Man's wish for his father's death, with the circumstances, and approximate date of its emergence. He also spoke of it in relation to the punishment the patient's father apparently inflicted on him for a reason connected with masturbation. This childhood scene, or rather the mother's account of it, was recalled as a result of a construction.

But it was in the case of the "Wolf Man," apropos of the authenticity of the primal scene, that the notion of construction really came to the fore. Freud emphasized in this connection that if primal scenes were simply fantasies, they would never become the basis for recovered memories. But since these dreams that frequently confirmed the self-same content were in his view "absolutely equivalent to a recollection," a patient's conviction of a scene's reality was "in no respect inferior to one based on recollection." Indeed, scenes "which date from such an early period and exhibit a similar content, and which further lay claim to such an extraordinary significance for the history of the case,

are as a rule not reproduced as recollections, but have to be divined—constructed—gradually and laboriously from an aggregate of indications" (1918b [1914], p. 51).

The issue came up once more in Freud's discussion of a young homosexual woman, where he expressed the view that the analyst's reconstruction of the origins of a patient's disorder belongs to the beginning of an analysis, before the analysand takes charge him or herself (1920a, p. 152).

Only in Freud's late paper on "constructions in analysis" (1937d) does he deal with the matter fully. Here again he stressed the preliminary nature of the analyst's work of construction in the two-step process of analysis, arguing that "the work of analysis consists of two different portions, that it is carried out in two separate localities, that it involves two people, to each of whom a distinct task is assigned" (1937d, p. 258). The analyst's job is to divine or rather to reconstruct what has been forgotten, based on clues that have escaped from oblivion. This work precedes that of the analysand, but this does not mean that "the whole of it must be completed before the next piece of work can be begun" (1937d, p. 260). In fact, "both kinds of work are carried on side by side, the one kind being always a little ahead and the other following upon it" (p. 260). The patient's work thus consists in accepting or refusing to accept the analyst's constructions, confirming them or failing to confirm them by means of recollections.

This is far removed from certain later deviations in analytic practice that promote the idea that the analyst be silent. Here we see a kind of practice that takes risks. Freud distinguishes the different meanings of the analysand's "Yes" and "No" and notes that although the "Yes" has no value unless it is followed by indirect confirmations, reciprocally the "No" can mean the incompleteness but not necessarily the inaccuracy of the construction. He goes even further, noting that "the false construction drops out, as if it had never been made; and, indeed, we often get an impression as though, to borrow the words of Polonius, our bait of falsehood had taken a carp of truth" (1937d, p. 262).

The epistemological status of constructions is illuminated by means of two analogies. The first is a comparison to the archeologist's "work of construction, or, if it is preferred, of reconstruction." The analyst and the archaeologist, Freud writes, "have an indisputed

right to reconstruct by means of supplementing and combining the surviving remains” (1937d, p. 259). The first, however, “works under better conditions and has more material at his command to assist him since what he is dealing with is not something destroyed but something that is still alive” (p. 259). The second analogy is more unexpected and in Freud’s discussion it follows an image of destruction, that of psychotic anxiety bound to an inaccessible memory of a terrifying event that actually happened. Freud suggests a parallel between constructions in analysis and delusions: “The delusions of patients appear to me to be the equivalents of the constructions which we build up in the course of an analytic treatment—attempts at explanations and cure, though it is true that these, under the conditions of the psychosis, can do no more than replace the fragment of reality that is being disavowed in the present by another fragment that had already been disavowed in the remote past” (1937d, p. 268). The distinct nature of truth in psychoanalysis is thus suggested by the notion of construction/reconstruction.

In 1937 Freud regretted that construction had not been the subject of as much later work as interpretation. It has been explored since, however, particularly in the work of Serge Viderman (1970), who developed the question of levels of certitude in relation to the deformations caused by repression, and adopted the notion from Hegel and Freud of a truth that must be constructed and not merely found.

SOPHIE DE MIJOLLA-MELLOR

*See also:* Amnesia; Anticipatory ideas; Archeology (metaphor); Autohistorization; Bernfeld, Siegfried; *Construction de l'espace analytique (La-)* [Constructing the analytic space]; Family romance; “From the History of an Infantile Neurosis” (Wolf Man); Historical truth; Historical reality; Intergenerational; Interpretation; Lifting of amnesia; Memories; Memory.

### Bibliography

- Freud, Sigmund. (1909d). Notes upon a case of obsessional neurosis. *SE*, 10: 151–318.
- . (1918b [1914]). From the history of an infantile neurosis. *SE*, 17: 1–122.
- . (1920a). The psychogenesis of a case of homosexuality in a woman. *SE*, 18: 145–172.

———. (1937d). Constructions in analysis. *SE*, 23: 255–269.

Viderman, Serge. (1970). *La Construction de l'espace analytique*. Paris: Denoël.

---

## “CONSTRUCTIONS IN ANALYSIS”

Freud’s “Constructions in Analysis” was written in 1937 and appeared in print at the end of the year. It appears that Freud wrote this technical article in response to criticisms of the interpretations offered by analysts to their patients. The article begins with the question of evaluating the “yes” and “no” of the patient in response to an interpretation and with a justification of a technique intended to take into account the defensive value of negation. The goal of analysis is to expose repressed elements and enable the person to experience reactions that are commensurate with their level of maturity and to restore a more accurate image of a forgotten past. To achieve this the analyst has recourse to various signs and indicators: fragmentary and distorted memories that arise in dreams, ideas alluding to repressed elements, and the repetition in transference of repressed affects. Analysis proceeds on two levels—manifest and latent.

The analyst’s job is to use the indications provided by the patient to construct what has been forgotten and communicate it at an opportune moment. Unlike the work of the archeologist, psychoanalysis benefits from the fact that mental formations are not completely destroyed; however, the work of interpretation is more complex and preliminary since it also relies on the motivations of the analyst.

Construction covers an entire period of the analyst’s forgotten prehistory, while interpretation involves only a particular aspect of the analytic material. But how can its validity be evaluated? An incorrect construction, if it is isolated, does not cause any damage or provoke a reaction from the patient. The risk of suggestion is negligible however. The patient’s reactions to a construction are important indicators. The “yes” is equivocal and only has value when additional confirmation becomes available. The “no” only informs us about the incomplete nature of the construction. Indirect modes of response such as “I never thought of that” indicate that the analyst has touched an unconscious idea and are more reliable, but these are more a question of interpretation than construction. Equally valuable are the associations

and parapraxes that corroborate the construction; as is the case with a negative therapeutic reaction, a correct construction results in an aggravation of the clinical state.

However, constructions are only suppositions that await confirmation. When the construction is correct the patient will have a sense of conviction; even though the memory may not have been recalled, the construction will have the same therapeutic effect. Occasionally, a construction leads to very clear memories in the vicinity of what was constructed. Defensive displacement contributes to the quasi-hallucinatory quality of such recollections.

Based on the foregoing, it is possible that even in psychosis hallucinations are a return of forgotten events (seen or heard) from the first years of life, which have been distorted or subjected to other forms of defensive activity such as displacement. Thus, the upward pressure during psychosis would involve both desire and the repressed, distorted as in dreams. Delusions would also be constructions containing “a kernel of historical truth,” denied originally and drawing their strength of conviction from their infantile source. The analysand, like the hysterical patient, suffers from reminiscences. Basically, the compelling force of the analyst’s construction is similar to the delusion: the restoration of a piece of lived history. More generally, humanity’s beliefs are inaccessible to criticism since they contain an element of historical truth concerning a forgotten primitive past.

Although considered a technical article, Freud’s essay later helped elevate the term “construction” to the rank of a psychoanalytic concept. The emphasis is on repetition and the relationship between conviction and historical truth. Memory traces become more important than desire or fantasy, which leads to rich possibilities for the treatment of psychotic delirium. A dialectic process can be identified between the rediscovered past and the construction as a creation associated with the treatment.

CHRISTIAN SEULIN

*See also:* *Construction de l'espace analytique, La* (Constructing the analytical space); *Construction/reconstruction*; “From the History of an Infantile Neurosis” (Wolf Man); *Historical reality*; *Interpretation*.

### Source Citation

Freud, Sigmund. (1937d). Konstruktionen in der Analyse. *Internationale Zeitschrift für Psychoanalyse*, 23: 459–469; *G.W.*, 16: 43–56; *Constructions in analysis. SE*, 23: 257–269.

### Bibliography

- Fédida, Pierre. (1978). L'identité. L'économie du théorique. Autour du texte sur “les constructions dans l'analyse.” *Psychoanalyse à l'Université*, 3 (11), 437–444.
- Katan, Maurits. (1969). The link between Freud’s work on aphasia, fetishism and constructions in analysis. *International Journal of Psycho-Analysis*, 50 (4), 547–553.
- Kofman, Sarah. (1983). *Un métier impossible. Lecture de construction en analyse*. Paris: Galilée.
- Pasche, Francis. (1988). Travail de construction ou, si l'on préfère, de reconstruction, S. Freud, in Third Symposium of the European Federation of Psychoanalysis, Stockholm, 1988, on “Construction and Reconstruction.” *Bulletin de la Fédération européenne de psychanalyse*, 31, 19–31.
- Viderman, Serge. (1970). *La construction de l'espace analytique*. Paris: Denoël.

---

**CONSULTATION.** *See* **Initial interview(s)**

---

## CONTACT AND PSYCHOANALYSIS

Josef Breuer was known in Vienna as the “man with hands of gold” because he “made contact” in a friendly, non-objectifying way with his patients. It was with him that Bertha Pappenheim invented the psychoanalytic method. Sigmund Freud began as Breuer’s student and Breuer sent him patients and “monitored” the evolution of their treatment. When Freud began to distance himself, the shift from chair to couch was gradually promoted: “Don’t touch me! Keep quiet!” as Emmy von N. said.

In *Totem and Taboo* (1912–13a), a festival of “touching,” *die Berührung*, appears more than seventy times in sixty pages in Part II, entitled “Taboo and Emotional Ambivalence.” In Laplanche and Pontalis’s *The Language of Psycho-Analysis*, however, the word

does not appear. In chapter 3 of *Totem and Taboo*, “Animism, Magic, and the Omnipotence of Thoughts,” Freud refers to Frazer’s distinction between magic based on similarity—we destroy a statue representing the being whose death we desire—and magic based on contiguity—we spread grease on the weapon that produced the wound (1912–13a, pp. 81–83). Roman Jakobson (1963) pointed out that the very essence of speech, the Freudian holy of holies, is directly bound up with *Totem and Taboo*: metaphor and metonymy are at work in Freud’s dream analysis as they are in Frazer’s magic.

“The two principles of association—similarity [*Ähnlichkeit*] and contiguity [*Kontiguität*—are both included in the more comprehensive concept of ‘contact,’” Freud writes. “Association by contiguity is contact in the literal sense, association by similarity is contact in the metaphorical sense [*im übertragenen Sinne*]. The use of the same word for the two kinds of relation is no doubt accounted for by some identity in the psychical processes concerned which we have not yet grasped” (1912–13a, p. 85).

The realm of touching permeates these writings of Freud’s. It takes in touching that is prescribed, essential from the very beginning of life, beneficial, soothing, healing. And it also includes proscribed touching, the touch of evil, the touch that kills. The realm of touch is par excellence a social realm.

But how does contact differ from touch? Touch is objectifying, it manipulates the body or objects. Contact is emotional; it establishes a relationship with a living being. By promoting “benevolent neutrality” in place of *freundlich* and *Wohlwollen* (to amicably desire what is Good and Gratifying for the other), analysts have distorted the Freudian message in a very particular way. To say “I’m listening” is to acknowledge the existence of the patient; to say “I understand” is to emphasize the reality of his or her thoughts, which the “haptonomy” of Franz Veldman (1998) describes as “existential affirmation” and “rational confirmation” of existence. But without real emotional contact, it is impossible to help a human being develop his or her sense of “basic security,” affective confirmation being essential to the growth of every individual. In Velman’s terms, it is the mobilization of “*philia*” that “unveils the Good of the other, recognizes him in the Good he can be.” Some have said that recognizing the other is the Supreme Good, “because where love awakens, the self, that

somber despot, dies” (Giordano Bruno, cited in 1911c [1910]).

BERNARD THIS

*See also:* Anna O., case of; Emmy von N., case of; Neutrality/benevolent neutrality; Taboo; Tenderness; *Totem and Taboo*.

### Bibliography

- Freud, Sigmund. (1911c [1910]). Notes on an autobiographical account of a case of paranoia. *SE*, 12: 9–79.
- . (1912–1913a). Totem and taboo. *SE*, 13: 1–161.
- Jakobson, Roman. (1963). *Essais de linguistique générale*. Paris: Minuit.
- Veldman, Franz. (1998). *Haptonomie, science de l'affectivité* (7th ed.). Paris: Presses Universitaires de France.

---

## CONTACT-BARRIER

Bion first used the term “contact-barrier,” which he borrows from Freud, in *Learning from Experience* (1962, p.17):

I shall now transfer all that I have said about the establishment of conscious and unconscious and a barrier between them to a supposed entity, that I designate a ‘contact-barrier’; Freud used this term to describe the neurophysiological entity subsequently known as a synapse. In conformity with this my statement that the man has to ‘dream’ a current emotional experience whether it occurs in sleep or in waking life is reformulated thus: The man’s alpha-function whether in sleeping or waking transforms the sense-impressions related to an emotional experience, into alpha-elements, which cohere as they proliferate to form the contact-barrier. This contact-barrier, thus continuously in process of formation, marks the point of contact and separation between conscious and unconscious elements and originates the distinction between them. The nature of the contact barrier will depend on the nature of the supply of alpha-elements and on the manner of their relationship to each other.

This contact-barrier, like a number of other concepts in psychoanalysis, can be seen as a structural concept, an area between conscious and unconscious, or as a function, a constant transformation of beta-into alpha-elements. It would result in what Freud saw as a permeable repressive barrier, in which the

conscious and unconscious are in constant symbolic communication. Bion also compares it to a continuous dream in interaction with conscious rational experience. An alpha-element *contact-barrier* gives emotional meaning, and resonance in communication with an external object, where the *contact-barrier* may be transformed into an impermeable beta-screen, and the internal communication between the conscious and unconscious is blocked.

HANNA SEGAL

*See also:* Alpha-elements; Beta-elements; Beta-screen; Love-Hate-Knowledge (L/H/K links); Physical pain/psychic pain; Psychosomatic limit/boundary; "Project for a Scientific Psychology, A".

### **Bibliography**

Bion, Wilfred R. (1962). *Learning from experience*. London: Heinemann; New York: Basic Books.

———. (1963). *Elements of psycho-analysis*. London: Heinemann.

---

## **CONTAINER-CONTAINED**

In *Elements of Psycho-Analysis* (1963), W. R. Bion writes that psychoanalytic theories contain a twofold defect: "on the one hand, description of empirical data is unsatisfactory as it is manifestly what is described in conversational English as a 'theory' about what took place rather than a factual account of it and, on the other, the theory of what took place cannot satisfy the criteria applied to a theory as that term is employed to describe the systems used in rigorous scientific investigation" (p. 1).

It is therefore necessary to "formulate an abstraction, to represent the realization that existing theories purport to describe" (pp. 1–2). As elements in psychoanalysis, these abstractions operate like alphabetical letters in the formation of words: through many different combinations, they offer the analyst an infinite number of possible adaptations and interpretations for understanding the vicissitudes of the transference through thought and, of course, through words.

By contrast, the classical model of psychoanalytic theory, like the ideogram in relation to the word, ultimately allows of only one possible form of thought.

Insofar as the analytic situation establishes the conditions for a new realization in the transference, the

elements of psychoanalysis need to be capable of representing the realization that they were originally used to describe and of being articulated like letters with other similar elements and, having been articulated, to be capable of forming a scientific deductive system.

Bion's first element, represented as ♀♂, can be defined as a dynamic relationship between the container and the contained, deriving from Klein's concept of projective identification. To become a psychic object, the projected element has to encounter a container, or a thinking function. The intrusive projected element is thereby associated with a masculine symbolism, and the containing receptive element with a feminine symbolism. This therefore establishes a model that represents the transference-countertransference dynamics between patient and analyst, without any starting assumptions as to the qualities that may emerge there.

Wilfred Bion thus returns to his original hypothesis, which relates to finding an element that can simultaneously define a realization in the treatment and the original realization relating to the patient's psychic life, past memories and the intense, even pathological, mechanisms of projective identification that can be associated with these. For him, the ♀♂ element also represents the apparatus of thought in which certain aspects can carry out an ♀ (or ♂) function for other ♂ (or ♀) aspects. Psychic growth therefore results from the integration of this mechanism when projective identification is operating normally. In the treatment of psychotic patients, the violence of the projective mechanisms hinders the ♀♂ "interlocking," which then creates a sense of dislocation.

W. R. Bion locates the container/contained dimension in the vertical axis of his grid. It represents the positive growth of thought; this element operates through its F part that is equivalent to the preconception, which is immersed in the M part that corresponds to realization and gives access to meaning. It only finally becomes operative if, through the integration of the container-contained element, the subject tolerates a primary bisexuality, with the beginnings of triangulation that accompany it.

JEAN-CLAUDE GUILLAUME

*See also:* Alpha function; Arrogance; Concept; Hallucination; Internal object; Psychic envelope; Psychotic panic; Realization; Relations (commensalism, symbiosis, parasitism);

Psychoanalytic setting; Selected fact; Skin; Thought-thinking apparatus.

### **Bibliography**

Bion, Wilfred R. (1963). *Elements of psycho-analysis*. London: Heinemann.

---

## **CONTRADICTION**

In its primary meaning, contradiction is the act of contradicting, of opposing oneself to someone by saying the opposite of whatever he or she says. The term is used in mathematics and philosophy. In mathematical logic, a contradiction is a statement whose truth function has only one value: false. In philosophy it is the relation that exists between the affirmation and the negation of a proposition. A term that embodies incompatible (contrary or contradictory) elements is also called a contradiction.

Contradicting the fears and feelings of a patient under hypnosis was the first therapeutic intervention that Freud described in his early article on “A Case of Successful Treatment by Hypnotism” (1892–93a). He showed that the etiology of the symptom depended on “antithetic ideas” (p. 121) opposed to the individual’s intentions. The formal element in the etiology was thus contradiction, which also applied to repression: “For these patients whom I analysed had enjoyed good mental health up to the moment at which *an occurrence of incompatibility took place in their ideational life*—that is to say, until their ego was faced with an experience, an idea or a feeling which aroused such a distressing affect that the subject decided to forget about it because he had no confidence in his power to resolve the contradiction between that incompatible idea and his ego by means of thought-activity” (Freud 1894a, p. 47).

*The Interpretation of Dreams* and the “first topography” increased the places in Freud’s theory where contradictory oppositions could be found within a single agency, between agencies, or between psychical reality and external reality. As early as 1900, Freud noted that “Thoughts which are mutually contradictory make no attempt to do away with each other, but persist side by side. They often combine to form condensations, just as though there were no contradiction between them, or arrive at compromises such as our conscious thoughts would never tolerate, but such as are often

admitted in our actions” (1900a, p. 596). The absence of contradiction, *Widerspruchslosigkeit*, at first an attribute of the primary process, later became a feature of the unconscious:

The nucleus of the Ucs. consists...of wishful impulses. These instinctual impulses are co-ordinate with one another, exist side by side without being influenced by one another, and are exempt from mutual contradiction. When two wishful impulses whose aims must appear to us incompatible become simultaneously active, the two impulses do not diminish each other or cancel each other out, but combine to form an intermediate aim, a compromise. There are in this system no negation, no doubt, no degrees of certainty: all this is only introduced by the work of the censorship between the Ucs. and the Pcs. Negation is a substitute, at a higher level, for repression” (Freud, 1915e, pp.186–187).

Freud used similar language apropos of the id, adding that “The logical laws of thought do not apply to the id, and this is true above all of the law of contradiction” (1933a [1932], p. 73). Ambivalence is the final dynamic factor necessary for understanding the ubiquity of contradiction in the expression of psychic processes.

Thus, all products of the unconscious—dreams, slips, jokes, symptoms—simply disregard “the category of contraries and contradictories... Dreams feel themselves at liberty, moreover, to represent any element by its wishful contrary; so that there is no way of deciding, at first glance, whether any element that admits of a contrary is present in the dream-thoughts as a positive or as a negative” (Freud, 1900a, p. 318). Freud compared these psychic creations to the antithetical meanings of primal words (1910e), which he again analyzed in his study of taboos (1912–1913), and then in his essay on “The Uncanny” (1919h). The term “compromise formation,” a feature of all defenses, demonstrates the extension of contradiction across the whole of mental life.

Contradiction intersects with negation and with the formal referential binary true/false. But Freud was especially interested in dynamic processes that allow contradictory mental positions to be maintained simultaneously. In addition to those already mentioned, he also referred to negation linked to repression, disavowal, splitting, and repudiation (or foreclosure, in Lacanian terms). Thus the contradiction between wish and reality



is systematic in relation to the difference between the sexes.

The notion of contradiction implies the formal expression of an opposition and its relation to truth. Mathematicians such as Kurt Gödel have shown that its domain of relevance is restricted. Structuralist linguists have distinguished oppositions based on contraries from those based on exclusion. Contradiction would appear to be a very rudimentary formal instrument for investigating psychic conflicts. Freud did not rely much on it, preferring the more dynamic terms “opposite” and “contrary.”

MICHÈLE PORTE

*See also:* Dream; Dream work; Illusion; *Interpretation of Dreams, The*; “Negation”; Primary process/secondary process; Reversal into the opposite; Sense/nonsense; Unconscious, the; “Unconscious, The”.

### **Bibliography**

- Freud, Sigmund. (1892–93a). A case of successful treatment by hypnosis. *SE*, 1: 115–128.
- . (1900a). The interpretation of dreams; Part I. *SE*, 4: 1–338; Part II. *SE*, 5: 339–625.
- . (1894a). The neuro-psychoses of defence. *SE*, 3: 41–61.
- . (1933a [1932]). New introductory lectures on psycho-analysis. *SE*, 22: 1–182.
- . (1915e). The unconscious. *SE*, 14: 159–204.

## **“CONTRIBUTIONS TO THE PSYCHOLOGY OF LOVE”**

“Contributions to the Psychology of Love” is the title given collectively to three articles by Sigmund Freud: “A Special Type of Choice of Object Made by Men,” published in 1910; “On the Universal Tendency to Debasement in the Sphere of Love,” published in 1912; and “The Taboo of Virginity,” published in 1918. It was Freud himself who, believing they formed a whole, decided to publish them under a single title.

In “A Special Type of Choice of Object Made by Men,” Freud considers men who are interested only in women over whose affections they must compete with another man; women who by virtue of their sexual life have something of the prostitute about them

and for that reason are more exciting. The lover of this type proposes to save the woman he desires, though he readily accepts the presence of his rival. Freud explains this behavior by reference to the Oedipus complex (a term he used for the first time in the same year, 1910, that this article was published). What is involved here is a desire to steal the mother from the father, or at least share her with him. The mother has first been compared to a prostitute when, at puberty, the boy was obliged to acknowledge, after the idealization of childhood, that she too has had sexual relations. Thenceforward he feels he must save her from degradation. This pattern, Freud adds, is repetitive, because it can only result in disappointment.

In “On the Universal Tendency to Debasement in the Sphere of Love,” Freud discusses male impotence. This problem arises for the most part from an “incestuous fixation on mother or sister” (p. 180). Freud distinguishes two “currents” in erotic life: the “affectionate” and the “sensual.” The affectionate current is the older, as it was directed towards the infant’s earliest caretakers, that is, towards the primary object-choice, typically the mother. The sensual current reaches its acme during puberty but, coming into conflict with the oedipal prohibition, turns to other objects, while often remaining fixated to the first. It “can happen that the whole of a young man’s sensuality becomes tied to incestuous objects in the unconscious, or to put it another way, becomes fixated to unconscious incestuous phantasies. The result is then total impotence” (p. 182). But, Freud wonders, why is this relatively uncommon? His answer is that in many cases where the same factors are at work the upshot is sexual relations unaccompanied by pleasure. For the two currents to combine and produce complete satisfaction is unusual, and the solution that consists in directing each current to a different woman is very frequent. But, Freud adds, it is no doubt in the very nature of the instinct to remain ever unsatisfied in the choice of object. The gain, perhaps, is to be found in the processes of sublimation, the motor of the development of civilization.

In “The Taboo of Virginity,” the last of this set of three papers, Freud returns to some of the ideas concerning women briefly referred to in the previous article. He cites ethnologists according to whom, in certain so-called primitive peoples, a person other

than the husband deflowers the fiancée. This practice, according to Freud, is followed in order to protect the husband from danger. He then examines a number of causes for fear in this connection. The bleeding that results from the loss of virginity is associated with physical wounds and death. In a number of so-called primitives, all of sexual life is wrapped in taboos. The woman is feared because of the assumed loss of virility that occurs through physical contact with her and this activates the fear of castration, especially as a result of her first sexual intercourse. But these general considerations are inadequate in Freud's view. The analysis of female frigidity, he argues, leads us to consider such other factors as the Oedipus complex, penis envy, the desire to obtain a child from the father as reparation, and hostility towards any man who appears as a poor substitute for the true object of this ancient desire. Thus the husband who avoids deflowering his wife acts thus because he fears losing his penis and, like Holofernes, his life.

ROGER PERRON

*See also:* Castration complex; Love; Oedipus complex; Sexuality; Taboo of virginity; Tenderness.

### Source Citation

Freud, Sigmund. (1910h). Über einen besonderen Typus der Objektwahl beim Manne (Beiträge zur Psychologie des Liebeslebens I). *Jahrbuch für psychoanalytische und psychopathologische Forschungen*, 2: 389–97; *GW*, VIII: 66–77; A special type of choice of object made by men. *SE*, 11: 165–175.

———. (1912d). Über die allgemeinste Erniedrigung des Liebeslebens (Beiträge zur Psychologie des Liebeslebens II). *Jahrbuch für psychoanalytische und psychopathologische Forschungen*, 4: 40–50; *GW*, VIII: 78–91; On the universal tendency to debasement in the sphere of love. *SE*, 11: 179–190.

———. (1918a [1917]). Das Tabu der Virginität (Beiträge zur Psychologie des Liebeslebens III). *Sammlung kleiner Schriften zur Neurosenlehre*, Leipzig-Vienna: Vierte Folge, p. 229–251; *GW*, XII: 159–180; The taboo of virginity. *SE*, 11: 193–208.

## CONTROVERSIAL DISCUSSIONS (ANNA FREUD-MELANIE KLEIN)

The title, *Controversial Discussions*, refers to the protracted discussions between Anna Freud, Melanie Klein, their followers and members of the indigenous group of British analysts which took place in the British Psycho-Analytical Society between 1941 and 1946.

The Discussions involved scientific, educational, and administrative problems and had the aim of deciding whether the new views concerning child development and psychoanalytic technique to treat both children and adults proposed by Klein and her followers: Susan Isaacs, Paula Heimann, Joan Riviere, and others, were compatible with the classical view of psychoanalysis as understood by Anna Freud and her Viennese and Berliner colleagues: Willie Hoffer, Kate Friedlander, Barbara Lantos, Dorothy Burlingham, and others, or whether Klein should be expelled from the psychoanalytical community. The indigenous group of British psychoanalysts, composed of Ernest Jones, Sylvia Payne, James Strachey, Ella Sharpe, Marjorie Brierley, and others, tried to mediate between the two contenders and to reach a compromise which in the end managed to hold the British Psycho-Analytical Society together and led to the formation of three groups: the so called Freudians, the so-called Kleinians and the so-called Independents.

The *Controversial Discussions* were at the same time the peak and the symptom of longstanding tensions and disagreements between the British way of looking at psychoanalysis, mainly but not exclusively influenced by Klein, and that represented by the Continental analysts, gathered mainly around Freud and his daughter Anna. Those disagreements had already expressed themselves in the late twenties and the late thirties.

The tensions and divergences exploded when Freud and his family had to emigrate to London as a result of the Nazi persecutions and, after Freud's death in London, Anna and many Continental analysts decided to stay in England.

One should consider the various factors which contributed to the *Controversial Discussions*: longstanding personal rivalries, the difficult situation of Klein, whose daughter, Melitta Schmideberg, was in analysis with Edward Glover. Schmideberg became, together with Glover, one of Klein's fiercest critics, joining the group of Anna Freud. Also significant were the "prima

**CONTROL CASE.** *See* Supervised analysis

donna” types of personalities of both Anna Freud and Melanie Klein, the objective tensions created by the war, the difficulties of mourning Freud’s death for Anna and her group in those circumstances, but also the cultural background of the indigenous members of the British Psycho-Analytical Society, which allowed the debate to take place without it degenerating into a catastrophic ending.

In order to defend their views, the Kleinians were required to present four papers to an ad hoc committee of the British Psycho-Analytical Society made up of Edward Glover, Marjorie Brierley, and James Strachey, and chaired by Ernest Jones. The first paper was that of Susan Isaacs, “On the Nature and Function of Unconscious Phantasy” on January 27, 1943. Paula Heimann then read her paper on June 23, “Some Aspects of the Role of Introjection and Projection in Early Development.” A third paper was given on December 17, 1943, by Isaacs and Heimann, called “On Regression.” Finally, on March 1, 1944, Klein read her paper “The Emotional Life and the Ego Development of the Infant with Special Reference to the Depressive Position.”

Also very important were the papers on technique which were written by Anna Freud, Klein, Sylvia Payne, Ella Sharpe, and Marjorie Brierley, to illustrate different approaches to the handling of the transference and the way to interpret the defenses of the patients.

The Controversial Discussions are now considered one of the most important documents of the history of psychoanalysis (King and Steiner, 1992). Indeed, they allow the study in vivo of the conscious and unconscious complexities of the emotional, personal, cultural, institutional, and political tensions of what on the surface appeared to be only a scientific disagreement between different ways of approaching the study of psychic development.

RICCARDO STEINER

*See also:* British Psycho-Analytical Society; Freud, Anna; Glover, Edward; Isaacs-Sutherland, Susan; Jones, Ernest; Klein-Reizes, Melanie; *Psychoanalytical Treatment of Children*; Transference in children.

### **Bibliography**

Grosskurth, Phyllis. (1986). *Melanie Klein. Her world and work*. London: Hodder & Stoughton.

Hayman, Anne. (1989). What do we mean by phantasy? *International Journal of Psycho-Analysis*, 70, 105–114.

King, Pearl H.M., and Steiner, Riccardo. (1991). *The Freud-Klein controversies 1941–1945*. London and New York: Tavistock Publications-Routledge, New Library of Psychoanalysis.

Steiner, Riccardo. (1985). Some thoughts about tradition and change arising from an examination of the British Psycho-Analytical Society’s “Controversial Discussions”, 1943–1944, *International Review of Psycho-Analysis*, 12, 27–71.

---

## **CONVENIENCE, DREAM OF**

The “dream of convenience” is a dream described by Freud as fulfilling two of a dream’s essential functions: satisfying a wish and safeguarding sleep.

He first mentioned this type of dream in a letter to Wilhelm Fliess dated March 4, 1894 (letter 22): A young doctor (Josef Breuer’s nephew) is awakened early one morning so that he can go to work at his hospital ward. However, he immediately falls back to sleep and, in his dream, has “a hallucination of a notice-board over a hospital bed with [his] name on it” (p. 213); in the dream the thought comes to him that he does not need to wake up, since he is already in the hospital.

In *The Interpretation of Dreams* (1900a), Freud twice referred to “Herr Pepi’s dream”: in chapter 3, where he discussed the fulfillment of wishes in dreams, and in chapter 5, where he mentioned the dream’s role as “guardian of sleep” (p. 233). In chapter 3 he gave other examples of what he explicitly called “dreams of convenience”: for example, dreaming that he is drinking saves the dreamer the trouble of having to wake up to quench his thirst.

Freud did not especially develop a theory of this type of dream, which only represents a specific type of wish-fulfillment in dreams. In his last mention of this topic in “An Outline of Psycho-Analysis” (1940a), he illustrated this theme by again citing the case of the doctor who can continue to sleep by dreaming that he is already at the hospital, and two other dreams that fulfill wishes, one involving hunger and the other sexual desire. He reminded readers that dreams are in fact compromise formations (between renunciation and satisfaction).

Clinical practice often provides examples of dreams of convenience. Their interpretation cannot be limited

to “decoding” the meaning only within a particular category of dreams, because the dream involves the entire dynamic theory (conflicts between the instincts and the defenses).

ROGER PERRON

*See also:* Dream.

### **Bibliography**

Freud, Sigmund. (1900a). The interpretation of dreams. *SE*, 4–5.

———. (1940a [1938]). An outline of psycho-analysis. *SE* 23: 139–207.

———. (1950c [1887–1902]). Extracts from the Fliess papers. *SE*, 1: 173–280.

## **CONVERSION**

The term “conversion” and its definition appear for the first time in an 1894 article by Freud titled “The Neuro-Psychoses of Defense.” “In hysteria the incompatible idea rendered innocuous by its *sum of excitation* being transformed into something somatic, for this I should like to propose the name of *conversion* . . . . By this means the ego succeeds in freeing itself from the contradiction [with which it is confronted]; but instead, it has burdened itself with a mnemonic symbol which finds a lodgement in consciousness, like a sort of parasite, either in the form of an unresolvable motor innervation or as a constantly recurring hallucinatory sensation” (1894a, p. 49). In the Freudian terminology of the time, an “irreconcilable” idea is a desire that is incompatible with the subject’s moral ideals and consequently condemned and most often rendered unconscious.

Consequently, the concept is, from the beginning, located along the three axes that will structure all Freudian metapsychology: dynamic through the reference to “contradiction,” which will later be theorized as “conflict”; topographical through the reference to the unconscious, which is still only allusive but will quickly assume major importance; and economic through the idea of a displacement of the energy (this will later become the libido) of the mind to the body. From this Freud draws a therapeutic conclusion: “Breuer’s cathartic method lies in leading back the excitation in this way from the somatic to the psychical

sphere deliberately, and in then forcibly bringing about a settlement of the contradiction by means of thought-activity and a discharge of the excitation by talking” (1894a, p. 50).

Freud initially considered the mechanisms of conversion to be specific to hysteria, unlike the other defensive psychoneuroses (obsessions and phobias). There would be a predisposition to hysteria for reasons he believes are probably constitutional, through what he refers to as “somatic compliance” in the Dora case (1905e). However, the “choice of neurosis,” a problem to which he often returned, here finds only its modalities of realization; to these fundamental conditions must be added “trigger factors” rooted in personal history (childhood traumas such as early “seduction” experiences, that is, sexual assaults initiated by adults). This is Freud’s position during the first period of his career. Later, in 1915, he distinguished “conversion hysteria,” which used this mechanism to produce symptoms, from “anxiety hysteria,” dominated by phobic mechanisms but without being accompanied by any conversion phenomena (1915d). He also acknowledged that minor conversion phenomena can be found in situations other than so-called conversion hysteria (1916–17a).

It is important to remember that Freud quickly established the necessity of distinguishing psychoneuroses—to which hysteria belongs—from actual neuroses (neurasthenia, anxiety neurosis, hypochondria), whose source is not found in infantile conflicts but in current disturbances of the sexual function (1898a). In such cases the accumulation of sexual excitation that has not been released or has been released by unsatisfactory means (*coitus interruptus*, masturbation, and so on) is reflected in anxiety and somatic symptoms (these views were modified in *Inhibitions, Symptoms, and Anxiety*, 1926d), but without the symbolic dimension inherent in conversion phenomena.

While the notion “actual neurosis” went into a long decline, modern work in psychosomatic medicine has given it new currency. It is used to describe somatic disturbances, often serious, that appear to arise from a form of interaction between mind and body where energy “passes directly” from the mind to somatic functions without symbolic mediation, that is, without “mentalization” of the psychoneuroses (Marty, 1980).

ROGER PERRON

See also: Cécilie M., case of; Elisabeth von R., case of; “Fragment of an Analysis of a Case of Hysteria” (Dora/Ida Bauer); Hysteria; Hysterical paralysis; Innervation; Katharina, case of; Neurosis; Psychosomatic; Psychosomatic limit/boundary; Psychogenic blindness; Repression; Somatic compliance; Stammering; *Studies on Hysteria*; Sum of excitation; Symptom; Tics.

### Bibliography

- Freud, Sigmund. (1894a). The neuro-psychoses of defence. *SE*, 3: 45–61.
- . (1905e). Fragment of an analysis of a case of hysteria (Dora/Ida Bauer). *SE*, 7: 7–122.
- . (1915d). Repression. *SE*, 14: 146–158.
- . (1916–17a). Introductory lectures on psychoanalysis. *SE*, 15–16.
- Marty, Pierre. (1980). *Les mouvements individuels de vie et de mort* (Vol. II, *L'Ordre psychosomatique*). Paris: Payot.

## COPROPHILIA

The term “coprophilia” is used to describe a predilection for fecal and related matters. On January 4, 1898, Freud wrote to Wilhelm Fliess: “Today I am sending you No. 2 of the “dreckological” reports . . .” (1985, p. 291). In creating this neologism from the German word *Drek*, meaning mud, filth, excrement, he was, according to Max Schur (1975), testifying to the abundant amount of anal material in his self-analysis at the time.

Food can remind children of excrement: “He protests loudly—in the form of overcompensation—the successful overcoming of his coprophiliac inclinations,” Freud explained to his pupils (*Wiener Psychoanalytische Vereinigung, 1962–1975*, p. 177). Repression of an olfactory coprophilic pleasure can determine the choice of a fetish (*Three Essays on the Theory of Sexuality*, 1905d). In the same vein, on February, 24, 1910, he wrote to Karl Abraham: “I regard coprophilic olfactory pleasure as being the chief factor in most cases of foot and shoe fetishism” (1965a, p. 87).

He later indicated, in his article *On the Universal Tendency to Debasement in the Sphere of Love* (1912d), that when man changed to the erect position he raised his smelling organ above ground level. It was then that “the coprophilic instinctual components [ . . . ] proved incompatible with our aesthetic standards of culture” (p. 189). Reflecting in the same article on sexual

impotence of a psychic origin, he stated: “The excremental is all too intimately and inseparably bound up with the sexual; the position of the genitals—*inter urinas et faeces*—remains the decisive and unchangeable factor” (p. 189).

Coprophilia takes on an entirely different meaning in the light of work on mourning and the notion of loss. Reflecting on the subject of mourning, Karl Abraham (1924) detected in certain rites the link between loss and attachment to the content of the intestines. Given the specific features of the two opposite pleasures of anal eroticism, retention and expulsion, he distinguished the same opposition in the sadistic instincts. There would then be a link between the expulsion of the anal object and the melancholy that results from the expulsion of a person. Psychoanalysis thus facilitated the establishment of a link between melancholy, obsessional neuroses, and coprophilia. Abraham went on to write: “The coprophagic instinct seems to me to conceal a symbolism that is typical of melancholy” (1924, p. 444). The motion of introjection can then be considered as a psychic mechanism that is of central importance for melancholics.

DOMINIQUE J. ARNOUX

See also: Anality; Eroticism, anal; Feces; Melancholia; Anal-sadistic stage.

### Bibliography

- Abraham, Karl. (1924). Melancholia and obsessional neurosis. In *Selected papers of Karl Abraham* (pp. 422–432). London: Hogarth.
- Freud, Sigmund. (1905d). Three essays on the theory of sexuality. *SE*, 7: 123–243.
- . (1912d). On the universal tendency to debasement in the sphere of love. *SE*, 11: 177–190.
- Freud, Sigmund, and Abraham, Karl. (1965a). *A psychoanalytic dialogue: The Letters of Sigmund Freud and Karl Abraham: 1907–1926*. (Hilda C. Abraham and Ernst L. Freud, Eds.; Bernard Marsh and Hilda C. Abraham, Trans.). New York: Basic Books.
- Freud, Sigmund, and Fliess, Wilhelm. (1985c). *The complete letters of Sigmund Freud to Wilhelm Fliess: 1887–1904*. (Jeffrey Moussaieff Masson, Ed. and Trans.). Cambridge, MA and London: Belknap/Harvard University Press.
- Schur, Max. (1972). *Freud: Living and dying*. New York: International Universities Press.

Wiener Psychoanalytische Vereinigung. (1962–1975). Minutes 72, Scientific Meeting on March 10, 1909. In Herman Nunberg and Ernst Federn (Eds.), *Minutes of the Vienna Psychoanalytic Society* (Volume II: 1908–1910) (M. Nunberg, Trans.). New York: International Universities Press.

### Further Reading

Karpman, B. (1948). Coprophilia: a collective review. *Psychoanalytic Review*, 35, 253–272.

Tarachow, Stanley. (1966). Coprophagia and allied phenomena. *Journal of the American Psychoanalytic Association*, 14, 685–699.

Hollós and *Les trois cases blanches*, a drama by Alain Didier-Weill.

*Le Coq-Héron's* editorial committee has also formed a translation group. To date it has translated volume four of the *Oeuvres complètes* of Sándor Ferenczi and his *Journal clinique*, the Freud-Ferenczi correspondence, and Carl Spitteler's *Imago*.

JUDITH DUPONT

See also: Ferenczi, Sándor.

## COQ-HÉRON, LE

The review *Le Coq-Héron* includes essays on psychoanalysis, education, and the social sciences in general. It is published four to six times a year and there are several special issues for the presentation of “working documents.” The print run is between eight hundred and two thousand. The review was founded in 1969 by a group from the Centre Étienne-Marcel to make available to researchers at the center texts that were inaccessible (original articles or translations from English, German, Spanish, or Hungarian) and thereby promote dialogue among scholars.

After three private issues were distributed within the center, the review went public. Supported by the Centre National des Lettres, it maintained its special relationship with the Centre Étienne-Marcel. By June 2001, 165 issues had been published. The review is characterized by the fact that its editorial committee includes analysts from various schools who work together in a collegial environment. Participating in the review does not require that they abandon their differences or convictions, and the editorial committee tries to ensure that all psychoanalytic orientations are represented. To this end the review's bylaws stipulate that if even one of the editors wants an article published, it must be published, the other editors having the right to include their comments and criticisms.

The review has published articles by well-known authors (Freud, Ferenczi, Dolto, Balint, Lacan, Mannoni, Mahler, Hermann) as well as lesser known or even unknown authors in psychoanalysis and related fields. It has also published several full-length books including *Mes adieux à la maison jaune* by István

## CORRAO, FRANCESCO (1922–1994)

Francesco Corrao was an Italian physician, psychoanalyst, president of the Società Psicoanalitica Italiana (SPI) [Italian Psychoanalytic Society] from 1969 to 1974, and founder of psychoanalytic centers in Rome and Palermo. He was born in Palermo on December 14, 1922, and died in Rome on April 23, 1994.

Corrao studied medicine but was also interested in philosophy, especially epistemology and Greek thought. He studied psychoanalysis with Alessandra Wolf Stomorse, Princess of Lampedusa, who, after her marriage, moved to Palermo during the late thirties. It was Corrao, a member of the SPI from 1952 and a training analyst at the institute founded by Nicola Perrotti, who was entrusted with the task of bringing psychoanalysis to Sicily when Lampedusa settled in Rome.

Introduced by Lampedusa to the work of Melanie Klein, Corrao became interested in her ideas as expressed in the work of Wilfred Bion, especially their application to the psychoanalysis of group activities. Convinced of Bion's importance, he had him translated into Italian and worked to introduce his ideas in Italy, organizing seminars in Rome during the seventies. In 1969, colleagues and students met with Corrao in Rome, forming the “Pollaiolo” circle to train members in analysis. The Pollaiolo circle published a review entitled *Gruppo e Funzione Analitica*, which has recently been replaced by *Koinos*.

Corrao's writings have been collected into a volume entitled *Modelli psicoanalitici: Mito, Passione, Memoria*. He devoted much time to the institutional renewal of the SPI, introducing new bylaws (1974) while he was president and creating regional centers

for psychoanalysis, including one in Palermo (1976), where he organized the annual scientific seminars, Colloquia of Palermo.

ANNA MARIA ACCERBONI

*See also:* Italy.

### **Bibliography**

Corrao, F. (1992). *Modelli psicoanalitici. Mito passione memoria*. Laterza: Roma-Bari.

---

## **COUNTER-IDENTIFICATION**

The term “counter-identification” has two different uses. For English-speaking authors, it refers to an analyst’s unconscious identification with his or her patient and thus designates a counter-transferential attitude. For certain French authors, it designates the subject’s adoption of character traits, drive tendencies, or of defensive modes that are opposite to those of an object that the subject fears or with which he refuses to identify.

The first meaning is generally recognized by Anglophone authors. Robert Fliess defined it specifically as an irregularity in the counter-transference that must become a topic of the analyst’s self-analysis if it is to be overcome. Such a distortion of empathy results in a part of the analyst’s ego identifying with a part of the patient’s ego, causing the analyst to no longer observe the patient with the necessary analytic attitude. In consequence, the analyst might fail to recognize psychotic factors in the patient (Fliess, 1953). León Grinberg similarly described a “projective counter-identification” as “the result of an excessive projective identification that is not consciously perceived by the analyst, who consequently is ‘led’ by it. Thus the analyst conducts himself as if he had actually and concretely acquired, by assimilation, the features that were projected onto him” (Grinberg, 1962).

The other, less common meaning of the term characterizes the claims of certain patients who try to organize their lives opposite to those of their parents or intensely invested objects from their early childhood. A statement such as “I just don’t want to be like them” indicates a tactic that belongs to the domain of consciousness. This tactic is most often an attempt at negating an unconscious identification. The analysis

of such an identification remains one of the fruitful moments of the treatment.

ALAIN DE MIJOLLA

*See also:* Counter-transference; Identification; Transference in children.

### **Bibliography**

Fliess, Robert. (1953). Countertransference and counteridentification. *Journal of the American Psychoanalytic Association*. 1, 268–284.

Grinberg, León. (1962). On a specific aspect of countertransference due to the patient’s projective identification. *International Journal of Psycho-Analysis*. 43, 436–440.

Mijolla, Alain de. (1987). Unconscious identification fantasies and family prehistory. *International Journal of Psychoanalysis*. 1, 397–403.

---

## **COUNTER-INVESTMENT.** *See* Anticathexis

---

## **COUNTER-OEDIPUS**

The term “counter-Oedipus” generally designates the complete set of parental displays of the father’s or mother’s own oedipal conflict. Thus in these displays we can expect to find themes of incest and murder.

In numerous passages Freud discussed how parents replay their infantile Oedipus complex in the present, yet he never used the term “counter-Oedipus” to refer to these displays.

In 1979 Francis Pasche, returning to themes in Freud’s article “The Acquisition and Control of Fire” (1932a), analyzed the relationship of Zeus, Prometheus, and humankind in terms of a positive counter-Oedipus and a negative counter-Oedipus: Zeus, the “father of the gods,” subdued and mistreated Prometheus even though he belonged to a later generation. Prometheus, who revolted against Zeus, played a paternal role in relation to humankind.

In this perspective, the father is ambivalent toward the son when he is confronted with homosexual desires (as illustrated by Alain Fine’s myth of Laius the pedophile [1993]) and the desire to murder (Laius tried to kill Oedipus twice, once by exposure on

Cithaeron and then again later when he met him at the crossroads). Jacques Bril (1989) revealed the theme of murder of the son in Christ's passion. In fathers' relationships with daughters, we frequently encounter actual incest and tyrannical jealousy, as when fathers prohibit their daughters from having any sexual life.

Although we find the same fundamental themes of incest and murder in the counter-Oedipus of the mother, they are envisioned differently. In the mother's relationship with a daughter, primary homosexuality, long-term alienating bonds, and mother-daughter rivalry become important. In the mother's relationship with a son, the incestuous dimension of the child's penis comes to the fore. Additionally, whether the child be a boy or a girl, murder fantasies cause the mother to be anxious during pregnancy.

The notion of the counter-Oedipus thus brings together an extremely varied set of clinical facts and theoretical elements. Though it is a convenient term current in France, it still awaits full theoretical development. A task for the future is to relate the counter-Oedipus to transgenerational phenomena.

ROGER PERRON

*See also:* Adoption; Complex; Devereux, Georges (born György Dobo); Relaxation principle and neo-catharsis.

### **Bibliography**

Bril, Jacques. (1989). *L'affaire Hildebrand, ou le meurtre du fils*. Paris: Presses Universitaires de France.

Fine, Alain. (1993). Laios pédophile et infanticide. *Revue française de psychanalyse*, 57 (2), 515–524.

Freud, Sigmund. (1932a). The acquisition and control of fire. *SE*, 22: 183–193.

Pasche, François. (1979). Le "Prométhée" d'Eschyle, ou les Avatars du contre-œdipe paternel. *Revue française de psychanalyse*, 43 (3), 401–407.2

---

## **COUNTERPHOBIC**

We speak of *counterphobic* objects or phenomena when the person seeks out one or more external objects or phenomena, whether consciously or unconsciously, to escape from the manifestations of anxiety linked to his or her phobias.

The specificity of the counterphobic phenomenon appears to be linked not to the nature of the object

used, but rather to the function that object assumes within the person's psychic economy. In the phobic situation, anxiety is focused on an "external object" (which may be an object, a person, or a situation). In these conditions, the counterphobic object is that object whose link or relationship to the phobic object is sufficiently well established within the person's psychic economy that its presence can neutralize the anxiety associated with the phobic object.

Given the extreme heterogeneity of phobic phenomena, this perspective means that we need not attempt to make a clear distinction between the counterphobic object and the various types of objects described in other contexts that enable the person to escape from manifestations of anxiety (psychotic object, transitional object, fetish object, etc.).

FRANCIS DROSSART

*See also:* Claustrophobia; "Lines of Advance in Psycho-Analytic Therapy"; Neurotic defenses; Object; Phobia of committing impulsive acts; Phobias in children; Phobic neurosis; Prepsychosis; Symptom-formation.

### **Bibliography**

Diatkine, René, and Éric Valentin. Les phobies de l'enfant et quelques autres formes d'anxiété infantile. In *Nouveau Traité de psychiatrie de l'enfant et de l'adolescent*. Paris: Presses Universitaires de France, 1985.

Freud, Sigmund (1909). Some general remarks on hysterical attacks. *SE*, 9: 229–234.

Freud, Sigmund (1928). Fetishism. *SE* 21: 147–157.

Geissmann, Claudine and Pierre. *L'Enfant et sa Psychose*. Paris: Dunod, 1984.

Winnicott, Donald W. (1953). Transitional objects and transitional phenomena, a study of the first not-me possession. *Coll. papers, through paediatrics to psycho-analysis* (pp. 229–242). (Reprinted from *International Journal of Psycho-Analysis*, 34 (1951), 89–97.)

---

## **COUNTER-TRANSFERENCE**

Counter-transference refers to the analyst's unconscious reactions to the transference of the patient, including the feelings projected onto the analyst by the patient.

Sigmund Freud introduced the concept at the Nuremberg congress of the International Association of



Psychoanalysis in 1910: “We have become aware of the ‘counter-transference’, which arises in [the analyst] as a result of the patient’s influence on his unconscious feelings, and we are almost inclined to insist that he shall recognize this counter-transference in himself and overcome it” (Freud, 1910d, p. 144–145).

He spoke of it again in a letter to Ludwig Binswanger dated February 20, 1913: “The problem of counter-transference . . . is—technically—among the most intricate in psychoanalysis. Theoretically I believe it is much easier to solve. What we give to the patient should, however, be a spontaneous affect, but measured out consciously at all times, to a greater or lesser extent according to need. In certain circumstances a great deal, but never one’s own unconscious. I would look upon that as the formula. One must, therefore, always recognise one’s counter-transference and overcome it, for not till then is one free oneself” (letter 86f, p.112). He made reference to it again in “Observations on Transference-Love” (1915a [1914]): “For the doctor the phenomenon [the patient’s falling in love with successive analysts] signifies a valuable piece of enlightenment and a useful warning against any tendency to a counter-transference which may be present in his own mind” (p. 160).

In spite of these references, the notion of counter-transference remains ambiguous in Freud’s work. What are the analyst’s unconscious feelings? Can the analyst merely master the counter-transference or must he or she overcome it, which would imply a working-through? These three texts sowed the seeds of a theoretical and technical debate that developed after Freud’s death.

The conceptual tools needed for a theorization and explication of the counter-transference were introduced by Melanie Klein (1946) with her discovery of projective identification. This made it possible to understand how the patient could act upon the analyst’s psyche by projecting a part of his or her own psyche onto the analyst. Thus the counter-transference no longer appeared to be just the sum of the analyst’s blind spots, but instead became a way of perceiving certain aspects of the patient’s communication—primitive communication in particular. Melanie Klein did not use the term counter-transference very often, thought it could be said that her entire technique is founded on the concept.

It was her student Paula Heimann who, at the 1949 International Psychoanalytical Association conference

in Zurich, first made counter-transference a genuine tool for perceiving certain aspects of the patient’s communication: “My thesis is that the analyst’s emotional response to his patient within the analytic situation represents one of the most important tools for his work. The analyst’s counter-transference is an instrument of research into the patient’s unconscious” (1950, p. 81). From this point on, the concept became an object of increasing interest, most notably in relation to developing research in the fields of child analysis and the psychoses.

The definition of counter-transference remains controversial insofar as it is understood either strictly as a response to the unconscious processes that the patient’s transference produces in the analyst or more globally as the part played within the framework of the treatment by the analyst’s personality. In analytic work, this concept is used in two different ways: on the one hand, as a defensive position on the part of the analyst, who must take care to remain as much as possible a projective surface, a mirror, for the patient’s transference, and on the other, as a position in which the personality of the analyst, most notably his or her emotions, is engaged in the transference/counter-transference dynamic on the basis of a more three-dimensional conception of the transference. For the analyst, then, it is a matter of working through the counter-transference experience in order to distinguish between the patient’s projections and his or her own internal objects and see the common elements that might serve to guide the interpretation.

This concept carries two potential pitfalls. On the one hand there is a possibility of psychologizing the analytic relation to the extent that it could be considered more in terms of personal interaction than in terms of a transference repetition of unconscious scenarios (Fédida, 1986). On the other is the possibility of forgetting that while counter-transference can be a guide for understanding and the most faithful of servants, it can also be the harshest of masters (Segal, 1981).

CLAUDINE GEISSMANN

*See also:* Abstinence/rule of abstinence; Balint group; Boundary violations; Case histories/description; *Collected Papers on Schizophrenia and Related Subjects*; Complex (analytical psychology); *Development of Psycho-Analysis*; Elasticity; Empathy; Ethnopsychanalysis; Fourth analysis; Heimann, Paula; Initial interview(s);

Interpretation; Listening; Mutual analysis; Neutrality/benevolent neutrality; Nonverbal communication; Object relations theory; Projective identification; Psychoanalyst; Psychoanalytic treatment; Racker, Heinrich; Self-analysis; Silence; Supervised analysis (control case); Therapeutic alliance; Training analysis; Training of the psychoanalyst; Transference; *Transference and Countertransference*.

### **Bibliography**

- Fédida, Pierre. (1986) Le contre-transfert en question. *Psychanalyse à l'Université*, XI (41), 19–21.
- Freud, Sigmund. (1910d). The future prospects of psychoanalytic therapy. *SE*, 11: 139–151.
- . (1915a [1914]). Observations on transference-love (Further recommendations on the technique of psychoanalysis III). *SE*, 12: 157–171.
- Freud, Sigmund, and Binswanger, Ludwig. (2003). *The Sigmund Freud-Ludwig Binswanger correspondence: 1908–1938* (Arnold J. Pomerans, Trans.; Gerhard Fichtner, Ed.). New York: Other Press.
- Heimann, Paula. (1950). On countertransference. *International Journal of Psycho-Analysis*, 31, 81–84.
- Klein, Melanie. (1946). Notes on some schizoid mechanisms. *International Journal of Psycho-Analysis*, 27, 99–110.
- Segal, Hanna. (1981). Countertransference. In *The work of Hanna Segal*. New York: Jason Aronson.

### **Further Reading**

- Gabbard, Glen O. (1995). Countertransference: the emerging common ground. *International Journal of Psychoanalysis*, 76, 475–486.
- Greenberg, Jay R. (1991). Countertransference and reality. *Psychoanalytic Dialogues*, 1, 52–73.
- Jacobs, Theodore. (1999). Countertransference past and present: a review of the concept. *International Journal of Psychoanalysis*, 80, 575–594.
- Levine, Howard. (1997). The capacity for countertransference. *Psychoanalytic Inquiry*, 17, 44–68.
- Ogden, Thomas H. (1995). Aliveness and deadness of the transference and countertransference. *International Journal of Psychoanalysis*, 76, 695–710.
- Smith, Henry. (2000). Countertransference, conflictual listening and the analytic object. *Journal of the American Psychoanalytic Association*, 48, 95–128.
- Steiner, John. (1994). Patient-centered and analyst-centered interpretations: Some implications of containment and countertransference. *Psychoanalytic Inquiry*, 14, 406–422.

## **“CREATIVE WRITERS AND DAY-DREAMING”**

In 1908 Sigmund Freud presented a talk entitled “Creative Writers and Day-Dreaming” at the publisher Hugo Heller’s offices. This was an important article in which Freud responded to the questions introduced in “Psychopathic Characters on the Stage” (1942a [1905]). It is contemporary with the “Gradiva” essay (1907) and was to be continued in numerous texts that discussed artistic creation, such as “The Uncanny” (1919h) and “Dostoyevsky and Parricide (1928b [1927]). The condensed and theoretical nature of Freud’s statements here summarize ideas he was to present elsewhere in his work.

He begins with an idea that Donald Winnicott would later take up concerning the link between childhood games and creation—in this case, literary creation. The game is defined as a “daydream” and extends into adolescence in “fantasies.” Both belong to the more general category of fantasy activity, which is itself the result of unsatisfied desires. The link with literary creation takes place through popular literature, whose heroes are always victorious after they have undergone various trials. The pleasure of reading is defined as essentially narcissistic. The hero is always His Majesty the Ego and the “psychological” novel differs from the adventure novel only in that the ego is split into “partial egos” that are represented by the various heroes in conflict. The social novel, however, makes the ego an outside observer.

The novelist’s literary capacity is supported through the echoes that real events or folkloric sources awaken in his or her childhood memory. The creator allows the reader to participate in his fantasy world through the formal techniques he exercises, which provide a source of pleasure. This frees a deeper source, enabling the reader to “enjoy his fantasies without scruple and without shame.” Even though, as Freud himself acknowledges, the origin of this creative ability remains mysterious, this dense text introduces several new paths for discovery and reminds us of popular literature’s importance in understanding the pleasure of reading.

SOPHIE DE MIJOLLA-MELLOR

*See also:* Applied psychoanalysis and the interaction of psychoanalysis; Creativity; Literary and artistic creation; Fantasy (reverie); Reverie; Sublimation.

**Source Citation**

Freud, Sigmund. (1908e [1907]). Der Dichter und das Phantasieren. *Neue Revue*, 1, 716–724; Creative writers and day-dreaming. *SE*, 9: 143–153.

**CREATIVITY**

The term “creativity” is not used by Sigmund Freud but the concept is Freudian if we understand it to mean the creative imagination embodied in fantasies or daydreams. These may or may not receive further elaboration and be transformed into a work of art, regardless of its specific nature. However, it is primarily Melanie Klein and Donald Winnicott who are responsible for establishing the concept as an active attitude of the ego with respect to its objects.

As early as the *Studies on Hysteria* (1895d), Freud realized that the world of fantasy (Anna O’s private theater) can take the place of the real world, and this includes the researcher captivated by his subject. In discussing humor (1905c), Freud also emphasized the freedom of the intellect in the face of highly constrained situations. Literary creation (1908e [1907]) appeared to Freud as an extension of children’s daydreams, situations in which the fantasy is affirmed in the face of the empire of reality, without, however, leading the subject to misinterpret it as happens in delusional states. It is precisely this ability, whose origin remains mysterious, to turn fantasies into a reality inscribed in a work of art and therefore something that can be shared with others, that constitutes creativity, regardless of the field of endeavor. Freud was especially interested in literary (Dostoyevsky, Hoffmann, Jensen) and artistic creation (Leonardo da Vinci, Michelangelo).

Melanie Klein (1929) had a very different outlook on creativity, which she saw as an impulse experienced by the infant to repair the object that had been initially split into good and bad and attacked during the paranoid phase. The creative function is therefore initially curative but goes hand in hand with the representation of a unified object. In this sense the creative function constitutes a reconstitution of the ego and the object, which having been simultaneously destroyed, subsist in an empty or mutilated state.

Donald Winnicott (1971) gave the fullest extension to the concept of creativity by emphasizing its function as an attitude in the face of outside reality and not necessarily successful or recognized creative work. He

contrasted creativity and submission to the outside world but, unlike Freud, emphasized the fact that fantasy life could diverge from the creative attitude. Fantasizing is not living but can, on the contrary, as Freud noted with respect to hysterics, isolate the individual from life; it will never serve as an object of communication.

For Winnicott, while creativity is related to dreaming and living, it is not really a part of our fantasy life. The experience of self can only be achieved through that physical and mental creative activity whose model is game playing. Creativity is not the creative capacity but something universal, inherent in the very fact of living. In the case where the individual submits to outside reality to the point of losing himself in it (false self), his creativity disappears and remains hidden without however being destroyed. It is in this way deprived of contact with the experience of life. “The creative impulse,” Winnicott writes, “is present as much in the moment-by-moment living of a backward child who is enjoying breathing as it is in the inspiration of an architect who suddenly knows what it is that he wishes to construct” (1982, p. 69).

The concept of creativity is much closer to the question of activity than to the production of a work of art. This aspect is only sketched out by Freud but was theorized by Winnicott for whom the concept is associated with considerations of the ego and non-ego and the transitional space that serves as an “outlet” for primary narcissism.

SOPHIE DE MIJOLLA-MELLOR

*See also:* Literary and artistic creation; “Creative Writers and Day-dreaming”; Fantasy; Heroic Identification; Repetition; Reverie; Sachs, Hanns; Sublimation.

**Bibliography**

Freud, Sigmund. (1905c). Jokes and their relation to the unconscious. *SE*, 8: 1–236.

———. (1908e [1907]). Creative writers and day-dreaming. *SE*, 9: 143–153.

Klein, Melanie. (1975). Infantile anxiety situations reflected in a work of art and in the creative impulse. In *The Writings of Melanie Klein* (Vol. 1). London: Hogarth. (Reprinted from *International Journal of Psycho-Analysis*, 10, (1929) 436–443.)

Winnicott, Donald. (1982). *Playing and reality*. London: Routledge.

**Further Reading**

Nagera, Humberto. (1967). The concepts of structure and structuralization: psychoanalytic usage and implications for a theory of learning and creativity. *Psychoanalytic Study of the Child*, 22, 77–102.

Niederland, William. G. (1976). Psychoanalytic approaches to artistic creativity. *Psychoanalytic Quarterly*, 45, 185–212.

**CRIMINOLOGY AND PSYCHOANALYSIS**

Criminology is the “scientific” study of criminal behavior. Part of its mandate is to look for the causes of criminality. A distinction is made between general criminology, which coordinates and compares results from different criminological “sciences,” and clinical criminology, which is an interdisciplinary approach to the individual criminal (Pinatel, 1975). Criminalistics is the set of methods and scientific means used by law enforcement to search for criminals and establish their guilt.

It is customary to trace the origins of criminology to Cesare Lombroso (1836–1909), trained in medicine at Pavia and Padua, a volunteer in the Piedmontese army for seven years. A physician of Jewish origin, Lombroso became famous with the publication of *L’Uomo Delinquente* (Criminal man) in 1876. His countryman Enrico Ferri, a professor of law and sociology, was the author of *Criminal Sociology* (1917) and Raffaele Garofalo wrote *Criminologia* (1881), from which the term derives. Lombroso is notorious for his theory of “the born criminal,” based on the search for an “atavistic” factor in criminality (in fact part of a larger naturalistic quest for the origins of crime that ranged from the occipital lobe to a supposed “criminal chromosome”). It is too often forgotten, however, that he founded the comparative approach to large numbers and introduced the study of criminals’ writings. Historians of criminology put the true beginnings of the discipline almost a century before Lombroso. His genius lay in his ability to combine phrenology, anthropology, legal medicine and proto-psychiatry under the aegis of Darwinism (Mucchielli and Lantéri-Laura, 1994).

Sigmund Freud, who made no secret of his aversion to criminals, was silent about the work of his contemporaries in that area and singularly cautious when it came to applying psychoanalysis to criminology. In June 1906 he was invited to give a talk to Professor

Löffler’s students on the possible application of psychoanalysis to the “establishment of facts in legal proceedings” (1906c, p. 103). He directed his comments to future judges and lawyers, providing advice about the “interest in a new method of investigation, the aim of which is to compel the accused person himself to establish his own guilt or innocence by objective signs” (1906c, p. 103). This text has given rise to considerable misunderstandings, which have been discussed by François Sauvagnat (1992). Freud cautioned his audience about a considerable obstacle: the judge was likely to be misled by neurotics, who were liable to behave as if they were guilty. He gave free rein to his skepticism, taking but a few sentences to discuss the psychoanalytic method as having no practical application in legal matters given the risk of error entailed.

In “Criminals from a Sense of Guilt” (in 1916d, pp. 332–33), Freud goes a step further, based on his experience in treating subjects who had committed some minor offense during therapy: “He was suffering from an oppressive feeling of guilt, of which he did not know the origin, and after he had committed a misdeed this oppression was mitigated. His sense of guilt was at least attached to something” (p. 332). The origin of this obscure feeling of guilt was the Oedipus complex, with its implications of criminal intent: “killing the father and having sexual relations with the mother” (p. 333). Freud hypothesized that this could clarify our understanding of some criminals but he was careful to exclude those who did not have such feelings, those who were without moral inhibitions, and those who rationalized their struggle against society.

It would have been easy to make use of the Oedipus complex to account for criminal acts, especially patricide. In 1931, Freud was asked by Joseph Hupka, a professor of law at the University of Vienna, to provide testimony during a review of the trial of Philipp Halsmann, accused of having killed his father. In examining both possibilities, guilt or innocence, Freud steered a careful course between a defense of psychoanalysis and his ethical reservations concerning its use; he again exercised considerable caution, writing, “because it is always present, the Oedipus complex is not suited to provide a decision on the question of guilt” (1931d, p. 252).

Apropos of his rare allusions to the relationship between psychoanalysis and criminology, it must be said that Freud’s prudence has proved salutary. It was

subsequently evident that an overly hasty application of psychoanalysis can mechanically alter the role of fantasy, or generalize unconscious feelings of guilt, or even sustain the illusion that psychoanalysis might one day conquer the world of law.

Sándor Ferenczi must be mentioned here, not only for his hope of contributing to the development of a psychoanalysis of crime, but also for the richness of his theoretical and clinical ideas, which served as the foundations of a psychoanalytic understanding of victimhood, especially in his accounts of identification with the aggressor and introjection of the aggressor, who “disappears as external reality and becomes intrapsychic.”

DANIEL ZAGURY

*See also:* Act, passage to the; Acting out/acting in; Aimée, case of; Alexander, Franz Gabriel; Cénac, Michel; Ellenberger, Henri Frédéric; Guilt, unconscious sense of; Lacan, Jacques-Marie Émile; Lagache, Daniel; Law and psychoanalysis; Parricide/murder of the father; Schiff, Paul.

### **Bibliography**

- Balier, Claude. (1988). *Psychanalyse des comportements violents*. Paris: Presses Universitaires de France.
- Ferri, Enrico. (1967). *Criminal sociology* (Joseph I. Kelly and John Lisle, Trans.). New York: Agathon. (Original work published 1917)
- Freud, Sigmund. (1906c). Psycho-analysis and the establishment of facts in legal proceedings. *SE*, 9: 97–114.
- . (1916d). Some character-types met with in psychoanalytic work. *SE*, 14: 309–333.
- . (1931d). The expert opinion in the Halsmann case. *SE*, 21: 251–253.
- Garofalo, Raffaele. (1891). *Criminologia*. Turin: Fratelli Bocca.
- Lacan, Jacques. (1975). Motifs du crime paranoïaque: le crime des sœurs Papin. In *De la psychose paranoïaque dans ses rapports avec la personnalité*. Paris: Le Seuil. (Original work published 1933)
- Lantéri-Laura, Georges. (1994). *Recherches psychiatriques: Vol. 1. Sur le langage*. Paris: Sciences en situation.
- Legendre, Pierre. (1989). *Le crime du caporal Lortie, traité sur le père*. Paris: Fayard.
- Mucchieli, Laurent. (1994). *Histoire de la criminologie française*. Paris: L'Harmattan.

Pinatel, J. (1975). *Traité de droit pénal et de criminologie* (Vol 3: Criminologie, 3rd ed). Paris: Dalloz.

Reik, Theodor. (1973). *Le besoin d'avouer: psychanalyse du crime et du châtement*. Paris: Payot.

Sauvagnat, François (Ed.). (1992). Les coordonnées historiques de la distinction acting-out / passage à l'acte. In *Le souci de l'être: Le soin en psychiatrie*. Paris: GRAPP-Le Seuil.

Zagury, Daniel. (1996). Entre psychose et perversion narcissique, une clinique de l'horreur: les tueurs en série. *L'Évolution psychiatrique*, 59 (1).

### **Further Reading**

Goldberg, Arnold. (2003). Addendum to Freud's "Criminals from a sense of guilt." *Psychoanalytic Quarterly*, 72, 465–468.

---

## **CRUELTY**

Cruelty is a multi-faceted concept in Freud's work. It can relate to actions and motivations but also to agencies, events, or destiny. When Dora (1905e [1901]) abruptly terminated her analysis, Freud mentioned the young girl's "cruel impulses and revengeful motives" (p. 120), which, through Freud in the transference, were directed at Herr K. and through him at her father. This text, written in 1901, contains an implicit question as to whether these impulses originate from the drives or the ego, but also as to the type of person associated with these impulses: in fleeing the transference, did Dora intend to be cruel towards Freud?

An "instinct of cruelty" appears in the *Three Essays on the Theory of Sexuality* (1905d). In this work, Freud relates it to male sexuality: the man has a tendency to subjugate in order to overcome "the resistance of the sexual object" (p. 158) and satisfy his sexual urges. Freud states: "There is an intimate connection between cruelty and the sexual instinct" (p. 159). Along with scopophilia and exhibitionism, cruelty is classified as a partial or component drive. Whether active or passive, it also stems from the drive for mastery. Whereas this drive is exerted through the "apparatus for obtaining mastery" (p. 159), connected with the musculature, it is the skin, as the "erotogenic zone *par excellence*" (p. 169) that constitutes "one of the erotogenic roots of the passive instinct of cruelty" (p. 193). Freud also refers to Jean-Jacques Rousseau's memories of being beaten, which he goes on to discuss further in "A Child is Being Beaten" (1919e).

Like mastery, cruelty involves the use of the object simply as a means of satisfaction. In this sense, it differs from the “sadism proper” (1924c, p. 163) that results from the binding of the drive for cruelty with the sexual drive towards the object. Whereas the drive for cruelty, like the drive for mastery, is characterized by indifference on the part of the subject to the feelings experienced by the object of satisfaction, considered as a part-object, sadism involves a pleasure derived from the object’s suffering.

Describing sadism in *Instincts and their Vicissitudes* (1915c) as “the exercise of violence or power upon some other person as object” (p. 127), having also described the drive for cruelty in this way ten years earlier, Freud added: “the sadistic child takes no notice of whether or not it inflicts pain, nor is it part of its purpose to do so” (1915c, p. 128). Thus, strictly speaking, the small child is cruel but not sadistic. This becomes possible only after he has discovered the total object and his ambivalence towards it.

In the same year (1915b), Freud specifically related cruelty to egotism. Intrinsically neither good nor bad, the drives acquire these qualities with regard to the necessary process of civilization. But the child is able to renounce drive gratification because of his need to be loved by his libidinal object. However, the object still remains an unloved and sometimes hated stranger as a direct result of its otherness. Egoistic and cruel impulses resurface and are directed at the object, particularly if the object is generally designated as an enemy. Wounded by these attacks, the object becomes even more frightening.

After the introduction of the death drive in 1920, the drive for cruelty gave way to the “destructive drive,” understood as an external deflection of the death drive (1923b) and described as aggressive when directed at objects. If it is taken up by the ego, the ego itself becomes cruel or sadistic. The ego then risks not only losing the object’s love but also being subjected to the reprimands of the superego. This agency, which equates with moral conscience, can demonstrate an extreme cruelty, according to the need for aggression aroused by present and past frustrations. Rebellious by nature towards what is nevertheless the necessary process of civilization, the human being is always able to display a “cruel aggressiveness” (1930a, p. 111) if circumstances lend themselves to this.

Melanie Klein substantially developed this concept of cruelty on the part of the superego. In the context of

the controversy that pitted her against Anna Freud, she drew attention to the extreme severity of the infantile (or early) superego, even where the parents are conciliatory (1927). The harshness of the agency is proportional to the aggression felt by the child as a result of the frustrations experienced during weaning and toilet training. Thus a cruel superego, “something which bites, devours and cuts” (1928, p. 187) is the outcome of the oral-sadistic and anal-sadistic drives. Taking up Freud’s hypothesis concerning the necessary external projection of the death drive, to which the effects of pre-oedipal frustrations are added, Melanie Klein described an extremely cruel child who “attacks its mother’s breast” (1933, p. 253), “thinks of sucking out and eating up the inside of its mother’s body” (p. 254) and attacks its object with excrements that are “regarded as burning and corroding substances” (p. 253). This intense hostility both from the object and toward it is the product of the deflection of the death drive and past frustrations but also of fears of reprisal for the hostility towards the hated object, ultimately of the influence of the early superego. Thus, “the small child becomes dominated by the fear of suffering unimaginable cruel attacks, both from its real objects and from its super-ego” (p. 251). Although the oedipal phase is influenced by the earlier stages, these destructive rages are tempered with pity and some reparative impulses emerge.

Donald Winnicott (1955/1975) has clearly demonstrated the process of transition from a “pre-ruth era” in which the little child can inadvertently or unintentionally display aggression, since “if destruction be part of the aim in the id impulse, then destruction is only incidental to id satisfaction” (p. 210), to a subsequent stage when the child is concerned about his object. He then has worries about it and is able to feel compassion or potentially creative reparative wishes, which prevents him from remaining cruel toward his object.

Of course, these drives are primitive and potentially cruel toward the object. Throughout his life, the subject will have to find compromises between the claims of the narcissistic pole of his drives and the intensity of his love for the object. However, the object’s tolerance of the subject’s drive-based egoism varies. In fact, some parents and spouses are better able than others to tolerate narcissistic egocentrism in their child or partner and are accordingly less vulnerable to their “cruelty”.

ANNETTE FRÉJAVILLE

*See also:* Mastery, instinct for; Object; Pair of opposites; Reaction-formation; Sadism; Sadoomasochism; Superego; *Three Essays on the Theory of Sexuality*; Violence, instinct of.

### Bibliography

- Freud, Sigmund. (1905d). Three essays on the theory of sexuality. *SE*, 7: 123–243.
- . (1905e). Fragment of an analysis of a case of Hysteria. *SE*, 7: 1–122.
- . (1915b). Thoughts for the times on war and death. *SE*, 14: 273–300.
- . (1915c). Instincts and their vicissitudes. *SE*, 14: 109–140.
- . (1919e). “A child is being beaten”: a contribution to the study of the origin of sexual perversions. *SE*, 17: 175–204.
- . (1923b). The ego and the id. *SE*, 19: 1–66.
- . (1924c). The economic problem of masochism. *SE*, 19: 155–170.
- . (1930a). Civilization and its discontents. *SE*, 21: 57–145.
- Klein, Melanie. (1927). Criminal tendencies in normal children. In *Love, guilt and reparation and other works 1921–1945. The writings of Melanie Klein* (Vol. 1, pp. 170–185). London: Hogarth.
- . (1928). Early stages of the Oedipus conflict. *Love, guilt and reparation and other works 1921–1945. The writings of Melanie Klein* (Vol. 1, pp. 186–198). London: Hogarth.
- . (1933). The early development of conscience in the child. In *Love, guilt and reparation and other works 1921–1945. The writings of Melanie Klein* (Vol. 1, pp. 248–267). London: Hogarth.
- Winnicott, Donald W. (1975). Aggression in relation to emotional development. In *through paediatrics to psychoanalysis* (pp. 204–218). London: Hogarth. (Original work published 1955)

## CRYPTOMNESIA

Cryptomnesia is a memory that has been forgotten and then returns without being recognized as such by the subject, who believes it is something new and original. In general, the memory returns in the form of an idea or intuition, but reappearances in the form of actions have also been included.

The word was first used by the Geneva-based psychiatrist Théodore Flournoy in *From India to the Planet Mars: A Case of Multiple Personality with Imaginary Languages* (1901/1994), his book about the case of the spiritualist medium Catherine-Élise Müller, who used the name Hélène Smith. It thus comes out of an attempt at a rational approach to spiritualist phenomena that showed a delusional character: “In the communications or messages provided by mediums, the first (but not the only) question that arises is always whether, where spiritualists see the influence of disembodied spirits or some other supranormal cause, one is not simply dealing with cryptomnesia, with latent memories on the part of the medium that come out, sometimes greatly disfigured by a subliminal work of imagination or reasoning, as so often happens in our ordinary dreams.”

In his thesis, “On the Psychology and Pathology of So-Called Occult Phenomena” (1902), and an article, “Cryptomnesia” (1905), Carl Gustav Jung expressed his belief that he had isolated this phenomenon in Nietzsche’s *Zarathustra*. Cryptomnesia was the object of a few studies or mentions until around 1920 (Géza Dukes, Sándor Ferenczi, Wilhelm Stekel). Thereafter, it was seldom mentioned in the psychoanalytic literature and was even rarer in the psychological and psychiatric literature.

The notion’s interest remains marked by the particular use Sigmund Freud made of it, from 1919, by linking it to the issue of the originality of his inventions. Entering into the category of forgetting, cryptomnesia indexes it with a univocal meaning, that of tempering a claim to the originality of an idea. In an article signed “F.” and titled “Note on the Prehistory of the Technique of Analysis” (1920), Freud acknowledged that a text by Ludwig Börne, *Die Kunst in drei Tagen ein Original-Schriftsteller zu werden* (How to become an original writer in three days; 1823), had served as a precursor to the technique of free association. Freud also mentioned his cryptomnesia with regard to Josef Popper-Lynkeus, Empedocles, and Wilhelm Fliess, and interpreted Georg Groddeck’s statements along these lines. It is known that he was sometimes reluctant to refer to himself as the inventor of psychoanalysis, invoking the contributions of Josef Breuer, and that in addition, in *The Psychopathology of Everyday Life* (1901), he made himself vulnerable to a claim of priority on the part of his friend Fliess by accusing himself of harboring the unconscious wish to

steal the idea of bisexuality from him. No doubt we should see in this problematic, to which Freud linked the meaning of cryptomnesia, the characteristic difficulty the man of science has in taking personal responsibility for a discovery that shakes the foundations of the very rationality he identifies himself with. Invoking cryptomnesia in this context arguably means maintaining the fiction of a subject-supposed-to-know guaranteeing that the knowledge was already there before the creator invented it.

ERIK PORGE

*See also:* Amnesia; “Autobiographical Study, An”; Flournoy, Théodore; Forgetting; Free association; Memories; Memory; Mnemic trace/memory trace; Repression.

### **Bibliography**

- Freud, Sigmund. (1920). A note on the prehistory of the technique of analysis. *SE* 18: 263–265.
- . (1923). Josef Popper-Lynkeus and the theory of dreams. *SE* 19: 259–263.
- Flournoy, Theodore. (1994). *From India to the planet Mars: A case of multiple personality with imaginary languages*. Princeton, NJ: Princeton University Press. (Original work published 1901)
- Jung, Carl Gustav. (1902). On the psychology and pathology of so-called occult phenomena. *Coll. works*, Vol. 1, London: Routledge and Kegan Paul.
- . (1905). Cryptomnesia. *Coll. works*, Vol. 1, London: Routledge and Kegan Paul; United States Bollingen Foundation.
- Trosman, Harry. (1969). The cryptomnesic fragment in the discovery of free association. *Journal of the American Psychoanalytic Association*, 17 (2), 489–510.

---

**CULTURAL HEREDITY.** *See* Cultural transmission

---

### **CULTURAL TRANSMISSION**

The term “cultural transmission” does not appear in Sigmund Freud’s work, but the idea is implicit in such notions as *cultural heritage* and *phylogenetic inheritance*. Freud believed that the (since abandoned)

biological precept, according to which “ontogenesis recapitulates phylogenesis,” could be applied to human psychic development. The notion of cultural transmission refers to the possibility that the acquisitions of an individual or of a culture can be transmitted to descendents and form the basis of cultural development.

Freud addressed the topic for the first time in *Totem and Taboo* (1912–13a), where he advanced the hypothesis that the feeling of guilt over the murder of the primal father had persisted over the centuries and still affected generations that could know nothing directly about it.

In Freud’s later works, the main mechanism of transmission was said to be identification, which ensconced the lost object in the ego, as described in “Mourning and Melancholia” (1916–17g [1915]), and finally produced an alteration in the ego that gave rise to the superego, as described in *The Ego and the Id* (1923b). In the *New Introductory Lectures* (1933 [1932]) Freud observed that the superego could be viewed as the outcome of successful identification with the parental agency, and as the natural and legitimate heir to the Oedipus complex. As the bearer of tradition, the superego was a true agent of cultural transmission from one generation to the next. In *Moses and Monotheism* (1939a [1934–38]) Freud returned to the idea of an archaic heritage and compared such inherited acquired characteristics to instincts in animals—an inheritance on par with symbolism.

After Freud, the idea of phylogenetic transmission was seemingly relegated to the background, as an explanation of last resort, and the emphasis shifted toward a detailed and expanded study of identifications. The point of departure for this was Freud’s remark in the *New Introductory Lectures*, in which he observed that the child’s superego was not formed in the image of the real or imaginary parents, but instead modeled on the parents’ superego. The main focus soon moved beyond direct parental and intergenerational identifications to more distant identifications, such as those with grandparents, ancestors, or mythical characters in family history, who re-emerge amid the descendents as a kind of actualization of family prehistory. The theme of the intergenerational (or transgenerational) appears in psychotherapeutic work with families, children, and adolescents, and sometimes gives the impression that this sphere of



observation is being invaded by the study of archaic identifications. The other area where this theme comes to the fore is work with survivors or descendents of survivors of the Holocaust or other genocides, such as those committed by Latin American dictatorships. In these two areas, the importance of secrets, the unspoken, or ancestral crimes that the family has decided to bury, is much in evidence. In the case of the survivors of genocide, there is an attempt to make the traumatic situation disappear by denying it representation. But the buried material reappears two or three generations later, as a ghost that occupies the place where the concealment of important aspects of the ancestor's life has produced a "blank" in the descendant's psyche. In such cases, we speak of "alienating identifications." A particular aspect of this type of intergenerational transmission was studied by Nicolas Abraham and Maria Torok (1972/1978), in relation to the problem of grief.

We thus see that a number of ideas are related: in Freud's work we encountered identification, phylogenetic heritage, and intergenerational process; in other authors, the notions of transgenerational transmission, "fantasies of identification" (de Mijolla, 1986), and "alienating identifications."

In summary, we may say that the concept of phylogenetic heritage has gradually been reconsidered, to the benefit of more detailed study of the mechanisms of possible transmission, notably identification, the core of the issue. The uncovering of alienating factors in the subject's prehistory, factors that can go back several generations, has come to the fore, replacing the ideas of "family romance" and "mythical descent," so well known to us since Freud. But emphasis on the intergenerational may push analytic work in the direction of applied psychoanalysis, so distancing it from a deeper understanding of the configurations and processes of the analytic situation, which is the prime locus of psychoanalytic discovery. This danger may even be exploited by the ever-renewed faces of resistance to psychoanalysis.

MADELEINE BARANGER

*See also:* Intergenerational; Ontogenesis.

### **Bibliography**

Abraham, Nicolas, and Torok, Maria. (1968). *The shell and the kernel: Renewals of psychoanalysis*. Ed. and trans.

Nicholas Rand. Chicago: University of Chicago Press, 1994.

Freud, Sigmund. (1912–13a). Totem and taboo. *SE*, 13: 1–161.

———. (1923b). The ego and the id. *SE*, 19: 1–66.

———. (1916–17g [1915]). Mourning and melancholia. *SE*, 14: 237–258.

———. (1933a [1932]). New introductory lectures on psycho-analysis. *SE*, 22: 1–182.

———. (1939a [1934–38]). Moses and monotheism: Three essays. *SE*, 23: 139–207.

Kaës, René; Faimberg, Haydée; Enriquez, Micheline, et al. (1993). *Transmission de la vie psychique entre générations*. Paris: Dunod.

Mijolla, Alain de. (1986). *Les Visiteurs du Moi, fantasmes d'identification* (2nd ed.). Paris: Les Belles Lettres.

---

## **CULTURE.** *See Civilization (Kultur)*

---

## **CURE**

Freud clearly stated that "the aim of the treatment will never be anything else but the *practical* recovery of the patient" (1904a, p. 253). He also declared that "Psycho-analysis was born out of medical necessity. It sprang from the need for bringing help to neurotic patients, who had found no relief through rest-cures, through the arts of hydropathy or through electricity" (1919g, p. 259).

Many of the arguments that divide psychoanalysts on the problem of the "cure" arise from their different conceptions they have of the term's meaning. The medical model leads to the idea that the cure is a matter of the disappearance of symptoms or lesions, or even of a *restitutio ad integrum* (restoration of health) that would actually be impossible in the mental field. Hypnosis and suggestion made disorders disappear as if by magic, but only temporarily, which is why Freud abandoned these techniques. He was more concerned with deeper causes and, from the time of *Studies on Hysteria*, he limited his own influence: "[Y]ou will be able too convince yourself that much will be gained if we succeed in transforming your hysterical misery into common unhappiness. With a mental life that has

been restored to health, you will be better armed against that unhappiness" (1895d, p. 305).

In the analysis of "Little Hans," he insisted that "a psychoanalysis is not an impartial scientific investigation, but a therapeutic measure. Its essence is not to prove anything, but merely to alter something" (1909b, p. 104). Thus the objective is "change," giving the patient a capacity to mobilize his defenses differently and more effectively to manage both the external and internal conflicts that the cure cannot prevent from returning. In a note to *The Ego and the Id*, Freud wrote that "analysis does not set out to make pathological reactions impossible, but to give the patient's ego freedom to decide one way or the other" (1923b, p. 50n).

It is necessary to remove all obstacles to the attainment of this goal, and that is the work of the treatment: the unconscious must "convey itself into the preconscious" (1900a, p. 610); treatment involves "overcoming the internal resistances" (1905a, p. 267); analysis "replaces repression by condemnation" (1909b, p. 145); the patient must "make the advance from the pleasure principle to the reality principle" (1919b, p. 312); and "the aim of the treatment is to remove the patient's resistances and to pass his repressions in review and thus to bring about the most far reaching unification and strengthening of his ego, to enable him to save the mental energy which he is expending upon internal conflicts, to make the best of him that his inherited capacities will allow and so to make him as efficient and as capable of enjoyment as possible" (1923a, p. 251). From this perspective, "partial or complete sublimation" represents, as Freud wrote to James Jackson Putnam in a letter of May 14, 1911, "the goal of [psychoanalytic] therapy and the way in which it serves every form of higher development" (1971a, p. 121).

Freud never concealed the pedagogic aspect of such a program. He insisted on several occasions that psychoanalysis was a kind of "after-education" (1916–17a, p. 451; 1940a, p. 175), even though he also maintained that the psychoanalyst must not fall into the role of an educator. Similarly, he often spoke out, right up to the end of his life, against the idea that a "schematic normality" could define the end of the treatment, adding that "The business of analysis is to secure the best possible psychological conditions for the functions of the ego; with that it has discharged its task" (1937a, p. 250).

A growing awareness of the death drive and the repetition compulsion led Freud to reconsider the

secondary gain from illness as an obstacle to the cure and to reexamine the role of the "negative therapeutic reaction." The latter, which satisfies unconscious guilt feelings and the need for punishment in the neurotic (through masochism), represents one of the most important obstacles to the satisfactory progress of a psychoanalytic treatment.

Freud's continuing efforts to describe and analyze the negative therapeutic reaction shows that he persisted in looking for this, in the sense of "change," despite his later pessimistic remarks. Other analysts broadened the concept of cure, even if certain remarks by Jacques Lacan seemed to devalue it. On February 5, 1957, after a lecture by Georges Favez on "The Encounter with the Analyst," Lacan expressed with the utmost clarity an idea that has since been greatly distorted by both his adversaries and partisans. He began by arguing against the idea that "if the measure of a therapeutic analysis is defined by its achieving the aim of producing a cure, that would mean that a therapeutic analysis is always something rather limited. All the same," he went on, "cure always seems to be a happy side effect—as I have said, to the scandal of certain ears—but the aim of analysis is not cure. Freud said the same thing himself, namely, that making cure the aim of analysis—making it nothing more than a means towards a specific end—leads to something like a short circuit that could only falsify the analysis. Thus analysis has another aim" (1958, p. 309).

Lacan made these remarks were within the context of an argument that pitted him against the idea of "therapeutic analysis" and against the aim of "cure"—defined by Sacha Nacht as the "disappearance of fear and the possibility of loving and being loved" (1960)—as extolled by the Psychoanalytic Institute of Paris. His remarks aimed at a "pure psychoanalysis" that Lacan associated with training analysis.

In any case, Lacan's remarks can be compared to a formulation of Freud's that is similar only if we neglect the fact that it involves the question of symptomatic suffering and not "cure." However, as stated at the outset, everything depends on how one understands the term: "The removal of the symptoms of the illness is not specifically aimed at, but is achieved, as it were, as a by-product if the analysis is properly carried through" (1923a, p. 251).

ALAIN DE MIJOLLA

See also: "Analysis Terminable and Interminable"; Analyzability; Archetype (analytical psychology); Change; Ego; Memory; Negative therapeutic reaction; Transference neurosis; Psychoanalytic treatment; Resolution of the transference; Termination of treatment; Therapeutic alliance.

### Bibliography

- Freud, Sigmund. (1900a). The interpretation of dreams. *SE*, 4 & 5: 1–751.
- . (1904a). Freud's psycho-analytic procedure. *SE*, 7: 247–254.
- . (1905a). On psychotherapy. *SE*, 7: 255–268.
- . (1909b). Analysis of a phobia in a five-year-old boy. *SE*, 10: 1–149.
- . (1916–17a). Introductory lectures on psychoanalysis. *SE*, 15 & 16: 1–496.
- . (1919b). Some character-types met with in psychoanalytic work. *SE*, 14: 309–333.
- . (1919g). Preface to Reik's ritual: psycho-analytic studies. *SE*, 17: 257–263.
- . (1923a). Two encyclopaedia articles. *SE*, 18: 235–259.
- . (1923d). The ego and the id. *SE*, 19: 1–66.
- . (1937c). Analysis terminable and interminable. *SE*, 23: 209–253.
- . (1940a). An outline of psycho-analysis. *SE*, 23: 139–207.
- Freud, Sigmund, et al. (1971a), *James Jackson Putnam and psychoanalysis. Letters between Putnam and Sigmund Freud, Ernest Jones, William James, Sándor Ferenczi, and Morton Prince, 1877–1917* (Nathan G. Hale, Ed.). Cambridge: Harvard University Press.
- Freud, Sigmund, and Josef Breuer. (1895d). Studies in hysteria. *SE*, 2.
- Lacan, Jacques. (1958). Intervention, in G. Favez: 'Le rendez-vous avec le psychanalyste.' *La Psychanalyse*, 4, 305–314.

### Further Reading

- Abend, Sander. (1979). Unconscious fantasy and theories of cure. *Journal of the American Psychoanalytic Association*, 27, 579–596.
- Eagle, Morris. (1993). Enactments, transference, and symptomatic cure: a case history. *Psychoanalytic Dialogues*, 3, 93–110.

Eissler, Kurt R. (1963). Notes on the psychoanalytic concept of cure. *Psychoanalytic Study of the Child*, 18, 424–463.

Kohut, Heinz. (Arnold Goldberg, ed.) (1984). *How does analysis cure?* Chicago & London: University of Chicago Press.

---

## CZECH REPUBLIC

The first pioneer of psychoanalysis in the Czech lands was Jaroslav Stuchlik (1890–1967), the Czech psychiatrist. He studied medicine in Switzerland, where he met with Eugen Bleuler and Carl Gustav Jung. At the end of the First World War, he was the first Czech to visit Freud's seminars in Vienna. He surrounded himself with a group of young physicians in Slovakia (Kaschau) in the 1920s.

Another group, consisting of Russian physicians, originated in Prague around the Russian emigré Nikolaj I. Osipov (1877–1934, who lived in Prague from 1921 until his death and founded the Russian Psychoanalytical Association with Drosnez, Tryto, and Viroubov. Osipov lectured in psychoanalytic psychiatry at Charles University in Prague.

Nicolaj Osipov and Jaroslav Stuchlik, along with Eugen Windholz, formerly of the group in Kaschau, initiated the idea of the commemorative plaque that was installed on Freud's home in Freiberg on October 25, 1931. Anna Freud took part in the celebration and Sigmund Freud, at that time 75 years old, sent a letter of greeting to participants. In connection with this event the first *Czech Yearbook of Psychoanalysis* (1932) appeared, edited by Windholz. Windholz (1903–1986), a Slovak Jew, was the first in the Czechoslovakian history to receive a proper psychoanalytical training. He started his analysis with Dr. Wolfe in the Berlin Psychoanalytical Institute where he spent few weeks in 1930. Then he continued his training in Prague with Frances Deri, a German analyst, who was the first émigré from Germany, followed by Heinrich and Yela Loewenfeld, Steff Bornstein. Hanna Heilborn, Annie Reich, and Elisabeth Gero-Heymann.

The Prague Psychoanalytical Study Group was established in 1933, led by Frances Deri until 1935, when she moved to Los Angeles and, after that, by Otto Fenichel, who trained and taught in Prague until 1938 as an emissary of the Viennese Psychoanalytical Society which was affiliated with the Prague Group officially at the Lucerne Congress in 1934. Among the

analysts from Vienna who traveled to Prague on weekends to present lectures were E. Bibring, R. Waelder, R. Spitz, P. Federn, E. Kris, and A. Aichhorn. Among the pupils were Emmanuel Windholz, Jan Frank, a Slovak psychiatrist and neurologist, Richard Karpe, a Czech pediatrician, Theodor N. Dosuzkov, a Russian émigré, neurologist and psychiatrist, and Otta Brief and Theresa Bondy. The Czech Study Group was officially recognized by the 14th IPA Congress in Marienbad in 1936. The Munich treaty in 1938 had disastrous consequences for the psychoanalytic movement: Czechoslovakia was occupied by Hitler in March 1939.

During the years 1938–1939, a majority of the Czech Study Group emigrated to the United States (Windholz to San Francisco, Frank to New York, Karpe to Hartford, Connecticut), some died in concentration camps, and the only member to survive the German occupation was Theodor Dosuzkov (1899–1982). He had been trained by Annie Reich and Fenichel supervised him. During the war he went on with his psychoanalytic work illegally, surrounding himself with a small group that played a significant role in the postwar development of psychoanalysis in Czechoslovakia.

The Society for the Study of Psychoanalysis was reestablished in Prague in 1946. It had to be dissolved officially at the beginning of the 1950s, after the Communist putsch, but it continued illegally a further 40 years (1950–1989). The training in psychoanalysis went on secretly. Theodor Dosuzkov and his pupils Otakar Kuera, Ladislav Haas (emigrated in 1965 to London), and M. Benová were direct members of the IPA, and had some private contacts with analysts

abroad. In the 1960s the younger generation of analysts started to train candidates: P. Tautermann, A. Sizková.

In the early 1980s, descendants of Dosuzkov and others established the new group and the Psychoanalytic Institute. Since 1987, the Czech Group has been visited by several important European and American psychoanalysts. An important step was made at the 26th IPA Congress in Rome in 1969: V. Fischelová, Jiri Kocourek, Vaclav Mikota, M. Šebek, and B. Vacková were recognized as the direct and associate members of the IPA. The Czech Group became a Study Group of the IPA at the 38th Congress in Amsterdam in 1983. The official journal of the Czech Study Group, *Psychoanalytický sborník*, has been published since 1989.

MICHAEL ŠEBEK

### **Bibliography**

- Fischer, Eugenia. (1992). Czechoslovakia. In P. Kutter (Ed.), *Psychoanalysis international, a guide to psychoanalysis throughout the world, vol. 1, Europe* (pp. 34–49). Stuttgart-Bad Cannstatt: Frommann-Holzboog, 34–49.
- Fischer, René. (1975). Zur Geschichte der psychoanalytischen Bewegung in der Tschechoslowakei. *Psyche*, 29, 12.
- Šebek, Michael. (1992). La psychanalyse, les psychanalystes et la période stalinienne de l'après-guerre. La situation tchécoslovaque. *Revue internationale d'histoire de la psychanalyse*, 5, 553–568.
- Šebek, Michael. (1993). Psychoanalysis in Czechoslovakia. *Psychoanalytic Review*, 80 (3), 433–439.



# D D

## DALBIEZ, ROLAND (1893–1976)

Roland Dalbiez, a French philosopher, was born in Paris on June 23, 1893, and died in Rennes on March 14, 1976. He is best known for his *Psychoanalytic Method and the Doctrine of Freud*, a philosophical critique of psychoanalysis published in 1936. Dalbiez was born into an aristocratic Christian family (his father was a general in the army and his mother a Churchill) and entered the French naval academy in 1911. He was a naval officer during the First World War. After contracting pleurisy he was forced to abandon the military and turned to philosophy, graduating in 1921 and receiving his doctorate in 1936. He spent his entire career as a professor in the literature department of the University of Rennes.

His research involved the boundaries between biology and metaphysics. Together with Professor Rémy Collin of the University of Nancy, he founded *Cahiers de philosophie de la nature* (The philosophy of nature), and published several studies on the theory of evolution.

In the early 1930s he was part of the circle of people around Jacques Maritain, the neo-Thomist philosopher, where he met Emmanuel Mounier and Maurice Merleau-Ponty. It was Maritain who encouraged Dalbiez to write about Freud. His research was so extensive that it turned into a dissertation. He defended his dissertation at the Sorbonne and it was published the same year by Desclée de Brouwer, as *La Méthode Psychanalytique et la Doctrine Freudienne* (Psychoanalytic method and Freudian theory). There were two volumes: The first included an account of Freud's ideas and the second a discussion. There was a preface by Henri Claude. Claude introduced Dalbiez as a student who had become personally acquainted

with the psychoanalytic method through his study, together with several psychiatrists, of various cases over a period of years.

Dalbiez insists on the fact that his judgment is not only based on what he has read but also on what he has seen. "On a number of points, books leave us with a feeling of uncertainty, but the facts are convincing." (p. 8) The main thrust of his dissertation is that while Freudianism is wrong for many reasons—exaggeration, eccentricity, dogmatism—the method is excellent and fruitful. Dalbiez essentially reproaches Freud for lacking philosophic rigor and behaving "as if he were unaware of the idea of proof." His principal merit is to have emphasized the primacy of the unconscious in mental life.

Dalbiez's friend Édouard Pichon provided a detailed review of the book in the *Revue Française de Psychanalyse* in 1936. He presents the work as "a milestone in psychoanalysis in France" and feels that the philosopher from Rennes will "convince even the most reluctant of philosophers that the psychoanalytic method represents a definite advance, something real and durable in the field of psychology." He fully accepted the distinction made by Dalbiez between Freudian doctrine, "about which we are free to accept what we wish," and method. Moreover, he claims to be the origin of this idea. At the beginning of the Second World War, Henri Ey also published an article entitled "Réflexions sur la Valeur Scientifique et Morale de la Psychanalyse (à propos de la Thèse de Roland Dalbiez)," which represented his first important statement about psychoanalysis.

The impact of Dalbiez's work on philosophy was less significant than it was in the analytic community.

There was no mention of the book in philosophical reviews of the time and, as Dalbiez himself notes, the book aroused considerable hostility at the Sorbonne. It was only gradually that it became an important work on the application of philosophy to psychoanalysis, primarily through the efforts of Paul Ricoeur, who was a student of Dalbiez. His book, especially the distinction he made between theory and method, was the source of considerable misunderstanding.

*See also:* Philosophy and psychoanalysis.

### **Bibliography**

- Codet, Henri. (1936). La méthode psychanalytique et la doctrine freudienne, compte rendu. *L'Évolution psychiatrique*, 3, 92–96.
- Dalbiez, Roland. (1972). *Psychoanalytical method and the doctrine of Freud*. (T. F. Lindsay, Trans.) Freeport, N.Y.: Books for Libraries Press. (Original work published 1936)
- Ey, Henri. (1939). Réflexions sur la valeur scientifique et morale de la psychanalyse: à propos de la thèse de Roland Dalbiez. *Encéphale*, 34, 189–220.
- Pichon, Édouard. (1936). De Freud à Dalbiez. *Revue Française de Psychanalyse*, 9, 4, 559–588.

## **DANGER**

As with many concepts a tentative definition of danger is based on its use in ordinary language: it signifies either a situation or set of circumstances that compromise the security or existence of a person or thing. Aside from the past or present, it can include future situations, that is, threats or risks having a high probability of realization. This definition likewise concerns threats to the operation of the mind.

The term “danger” appeared for the first time in Freud’s writings in an article entitled “On the Grounds for Detaching a Particular Syndrome from Neurasthenia under the Description ‘Anxiety Neurosis’” (1895b [1894]). Freud used it to define an external situation likely to provoke emotional and structural reactions. The danger forces the psychic apparatus to ensure the stability of its organization by implementing defensive measures intended to avoid a catastrophic disturbance (psychic trauma).

There are two dimensions to the concept: (1) In terms of clinical treatment and theory, it implies the

existence of two spaces, an external space with its own reality and an internal space that is part of what Freud named psychic reality (related to the later concept of reality-testing). (2) It entails the need to consider temporal differences, quantitative aspects, and specific effects. “Danger” refers to a situation that may have been accidental or contingent, consciously experienced, or unconscious.

This picture was later refined in Freud’s work, but it retained its initial features. Situations involving danger came to be viewed as more internalized and more specific: the dangers of separation and object-loss, of castration, of uncontrollable drives, of threats from an internal object. With the development of the second theory of anxiety, the concept of danger became more ambiguous, almost completely identified with the anxiety that signaled its presence. However, it is essential to distinguish clearly between the affects of anxiety (*Angst*), fright (*Schreck*), and fear (*Furcht*), each of which reflects a specific relationship to danger.

The notion of danger still has to be used with caution, especially in view of the inevitable and necessary evolution of psychoanalytic language, which now emphasizes psychic envelopes, the therapeutic setting, or a topography of “interfaces” rather than the older metapsychological models. There is also a risk of confusion with concepts from cognitive psychology and neurobiology (such as the concept of “stress,” for example).

CLAUDE BARROIS

*See also:* Animistic thought; Annihilation anxiety; Anxiety; Castration complex; Darwin, Darwinism, and Psychoanalysis; Ego; Ego function; Envy; Fright; Id; *Inhibitions, Symptoms, and Anxiety*; Negative transference *New Introductory Lectures on Psycho-Analysis*; Fear; Projection; Suicidal behavior; Symptom-formation; “Uncanny, The”.

### **Bibliography**

- Dayan, Maurice. (1985). *Inconscient et réalité*. Paris: Presses Universitaires de France.
- Freud, Sigmund. (1895b [1894]). On the grounds for detaching a particular syndrome from neurasthenia under the description “Anxiety Neurosis.” *SE*, 3: 85–115.
- Laplanche, Jean. (1980–87). *Problématiques*. Paris: Presses Universitaires de France.

## DARK CONTINENT

In *The Question of Lay Analysis* (1926e), Freud wrote, “We know less about the sexual life of little girls than of boys. But we need not feel ashamed of this distinction; after all, the sexual life of adult women is a ‘dark continent’ for psychology” (p. 212). The evocative phrase *dark continent* connotes a geographic space that is murky and deep, one that defies understanding. Freud borrowed the expression from the African explorer John Rowlands Stanley’s description of the exploration of a dark forest—virgin, hostile, impenetrable. By using this phrase and comparing the adult woman’s sexual life to an unknown continent, Freud indicates both his embarrassment as well as his explorer’s curiosity. He also emphasizes the obscure and incomplete nature of the clinical material on the sexual life of girls and women for the psychoanalyst. His metaphor for the female sex turns it into an unrepresentable enigma, expressing the castration anxiety of the man who approaches it. For although he insists on the central idea constituting his theory of female sexuality—namely, the primitive masculinity of the little girl, who is a little man before she changes objects and wishes to acquire a child from her father—Freud does have doubts about his theory.

If we consider his statements about female sexuality, a theory that was never really explained in a comprehensive manner, we see that Freud is close to being his most severe critic. In 1923, the year his most specific statements about female sexuality appeared, he presented, in “Infantile Genital Organization,” his thesis of the primacy of the phallus: “For both sexes, only one genital, namely the male one comes into account. What is present, therefore, is not a primacy of the genitals, but a primacy of the *phallus*.” He immediately adds, “Unfortunately we can describe this state of things only as it affects the male child; the corresponding processes in the little girl are not known to us” (1923e, p. 142).

However, Freud himself attempts to illuminate the darkness of the continent. For he discovers that for the little girl, the mother, who first provides care for the child, is the object of an especially intense and long-lasting cathexis. This archaic bond between mother and daughter, which psychoanalytic theory would later describe as one of primary homosexuality, is compared by Freud to Minoan-Mycenaean civilization, which had been hidden for so long by Athenian

civilization. Freud also insists on the function of the phallus for the woman. The phallus—not to be confused with the penis—is understood to represent the paternal function and the capacity for symbolization in all human beings. These ideas were further developed by Jacques Lacan and his school.

In Freud’s writing on femininity, a rigorous, sometimes even dogmatic, conceptualization always shares space with a sense of perplexity. But the invisibility of the female sex, its internal nature, a multiplicity of theories have been offered. Research by Freud’s disciples, such as Ernest Jones and Karen Horney, exposed new fields of exploration that are rich and heteroclit. Female psychoanalysts deepened the investigation of the female Oedipus and the young girl’s relationship to the phallic phase (Janine Chasseguet-Smirgel). Following Lacan, important work was done (Michèle Montrelay) on the “other” *jouissance*, which functions centrifugally in women, unlike the centripetal *jouissance* found in men. Influenced by the philosopher Jacques Derrida, there has also been important work on the feminine and the unrepresentable (Luce Irigaray). Finally, analysis of the female Oedipus resumed and was seen to consist of two phases (maternal object and paternal object, sensoriality and language) that constitute the basis of female bisexuality (Julia Kristeva).

JULIA KRISTEVA

*See also:* Activity/passivity; Aphanisis; Bisexuality; Castration complex; Feminine masochism; Feminine sexuality; Femininity; Feminism and psychoanalysis; Homosexuality; Masculinity/femininity; Object, change of/choice of; Oedipal complex; Phallic mother; Phallic stage; *Psychology of Women The. A Psychoanalytic Interpretation*; Sexual identity; Sexuation, formulas of; “Some Psychical Consequences of the Anatomical Distinction between the Sexes”; *Three Essays on the Theory of Sexuality*.

### Bibliography

- Chasseguet-Smirgel, Janine; Luquet-Parat, Catherine J.; Grunberger, Béla; et al. (1970). *Female sexuality: new psychoanalytic views*. Ann Arbor: University of Michigan Press. (Original work published 1964)
- Freud, Sigmund. (1923e). The infantile genital organization (an interpolation into the theory of sexuality). *SE*, 19: 141–145.
- . (1926e). The question of lay analysis. *SE*, 20: 183–250.



Irigaray, Luce. (1985). *Speculum of the other woman* (G. C. Gill, Trans.). Ithaca, NY: Cornell University Press. (Original work published 1974)

Kristeva, Julia. (2000). *The sense and non-sense of revolt* (J. Herman, Trans.). New York: Columbia University Press. (Original work published 1996)

Montrelay, Michèle. (1977). *L'ombre et le nom. Sur la féminité*. Paris: Editions de Minuit.

---

## DARWIN, DARWINISM, AND PSYCHOANALYSIS

In 1859, when Charles Darwin published *The Origin of Species*, Sigmund Freud was three years old. As a young student and later, during his early years as a dedicated scientific researcher, Freud greatly admired Darwin, who had gained considerable popularity throughout Europe. In his *Autobiographical Study*, Freud would recall that “Darwin’s doctrine, then in vogue, was a powerful attraction, since it promised to provide an extraordinary thrust to understanding the universe” (1925d). From then on Darwin joined Hannibal in Freud’s personal pantheon and he dreamed of becoming his equal. In “A Difficulty in the Path of Psycho-Analysis,” he described the three wounds inflicted on humanity’s pride: when Copernicus established that the earth was not the center of the universe, when Darwin proved that mankind developed in an unbroken line from other animal species, and when he, Freud, showed that man did not have control over the most important aspects of his own mental processes (1917a).

Freud cites Darwin at least twenty times in his published writings. It is possible, however, to identify three “Darwins” in Freud’s work:

The first Darwin is the Darwin of *The Expression of the Emotions in Man and Animals* (1872), referred to by Freud in the *Studies on Hysteria* (1895d), where Darwin is cited in connection with Emmy von N. and Elisabeth von R. Freud writes that Emmy von N.’s symptoms remind him “of one of the principles laid claim to by Darwin to explain the expression of the emotions—the principle of the overflow of excitation.” In describing Elisabeth von R., Freud emphasizes the symbolic meaning of her symptoms, which, he writes, “are part of the ‘expression of the emotional movements,’ as Darwin has taught.” Consisting “originally of acts that are well-motivated and appropriate,”

civilization has reduced and symbolically transposed the expressions into language.

This sort of reference occurs several times, especially in *Inhibitions, Symptoms, and Anxiety* (1926d), where the affects are “reproductions of earlier events of vital importance, possibly preindividual.” Adaptation is involved since “anxiety must fulfill the biologically essential function of reacting to a state of danger.” We can, therefore, consider the theory of anxiety presented in this work to be of Darwinian origin. Emotion (anxiety) is adaptive in two ways, for it prepares the animal for danger not just by mobilizing energy but also by aiding adjustment based on the nature of the threat (signal anxiety). However—and this too is taken from Darwin—under certain conditions the excess excitation can become disorganizing and non-adaptive.

The second Darwin is the Darwin of *The Origin of Species* (1859). This is the influence that is most often noted. It is used to support Freud’s views when he postulates a correspondence between phylogenesis (humanity’s evolution since its origins) and ontogenesis (the individual development of the child of today). Freud refers to Ernest Haeckel’s hypothesis according to which ontogenesis repeats phylogenesis. Freud writes, “Important biological analogies have enabled us to acknowledge that individual psychic evolution repeats, in abbreviated form, the evolution of humanity” (1910c). In “From the History of an Infantile Neurosis” (1918b), he writes, “The phylogenetic schemas that the child possesses at birth . . . are the precipitates of the history of human civilization . . . this instinctive heritage would constitute the core of the unconscious.”

This idea is central to *Totem and Taboo* (1912–13a), where it is used to establish the universality of primal fantasies, the Oedipus complex, and more generally the processes of development and human mentation. It occurs again in “A Phylogenetic Fantasy: Overview of the Transference Neuroses” (1985 [1915]), where the “prehistoric fantasy” (the expression is Freud’s) is used to establish a correspondence between three kinds of time: the time of the assumed succession of psychopathologies, that of phylogenesis, and that of ontogenesis.

Freud’s views were sharply criticized, even within psychoanalysis, for a variety of reasons, among them the questionable nature of the anthropological data on

which they were based and the impossibility of accepting Haeckel's hypothesis.

It is worth noting that in these texts (especially in the "Overview") Freud is more Lamarckian than Darwinian: it is essential to his theory that individual traits be transmissible by incorporation into the genetic heritage. Freud never abandoned this postulate in spite of the discredit that befell Lamarck's ideas.

The third and final Darwin is the Darwin of *The Descent of Man* (1871), a work that postulated a process of continuous evolution from animal to man and distinguished stages within human evolution, that is, a temporal sequence that was also a form of progress, a hierarchy ranging from the most primitive forms to the most noble: lower animals, higher animals, the "savage," civilized man. Darwin distinguished between "inferior" human races and "superior" races, even superior nations (such as Great Britain). Like many others at the time, Freud accepted these ideas and used them to support his views on the progress of civilization through the difficult, but necessary, repression of instinctual drives, a repression that made necessary the phenomenon of sublimation, which directed these energies to more "noble" ends.

This notion of the evolution of civilizations remains a source of continued interest. However, we can obviously no longer adhere to the idea of a hierarchy of values among human "races" that would "naturally" follow from the process of evolution as described by Darwin. And we know only too well what excesses and crimes "social Darwinism" can lead to. Nor is it any longer possible to postulate, as Freud once did, an equivalence between prehistoric humanity, or "primitive peoples" of today, and the child.

ROGER PERRON

*See also:* Brentano, Franz von; Heredity of acquired characters; Primitive horde; Phylogenesis; Totem, totemism; *Totem and Taboo*; Vienna, University of.

### **Bibliography**

Buican, Denis. (1987). *Darwin et le darwinisme*. Paris: Presses Universitaires de France.

Freud, Sigmund. (1910c). Leonardo da Vinci and a memory of his childhood. *SE*, 11: 57–137.

———. (1918b). From the history of an infantile neurosis. *SE*, 17: 7–122.

———. (1926d). Inhibitions, symptoms and anxiety. *SE*, 20: 75–172.

———. (1987 [1915]). *A phylogenetic fantasy: Overview of the transference neuroses*. (Axel Hoffer and Peter T. Hoffer, Trans.). Cambridge, MA: Belknap Press.

Ritvo, Lucile B. (1990). *Darwin's influence on Freud: a tale of two sciences*. New Haven: Yale University Press.

Thuillier, Pierre. (1981). *Darwin and co*. Brussels: Complexe.

---

## **DAY'S RESIDUES**

According to Freud's theory of dreams, day's residues are memory traces left by the events and psychic processes of the waking state; they are used as raw material by the dream-work that serves the wishes of the dreamer.

This idea is much in evidence in Freud's *The Interpretation of Dreams* (1900), and is consonant with his basic thesis that all dreams are wish-fulfillments. With the help of the relaxation of the defenses that sleep allows, unsatisfied wishes of waking life work their way to a fulfillment that is described as "hallucinatory," because though invested with an illusory reality, it is cut off from both perception and motricity.

This permeability of the censorship permits explicit daytime wishes to be represented in dreams. It may still oppose their expression in an overly crude form. However, the distorting mechanisms characteristic of the primary processes then come into play: condensation, displacement, and putting into images, or "representability." The mechanism of displacement lets the dream-work use the day's residues for the purpose of wish-fulfillment by producing innocent-seeming representations: whence the dreamer's impression, upon awakening, of details that are trivial, if not meaningless. An acceptable meaning may emerge, however, when secondary revision comes into play, giving the dream an intelligible "facade" and thus in fact perfecting the distortion.

The day's residues, perhaps in combination with sensory impressions occurring during sleep, constitute the "raw material" that will be reworked by the dream. Here Freud used the metaphor of work performed in the construction industry: daytime thoughts and the work to which they were subjected played the role of the contractor, while the unconscious wish was

comparable to the capitalist who finances the operation (furnishing its plan and the power for it).

Freud extended and rounded out this account in “A Metaphysical Supplement to the Theory of Dreams” (1916–1917f [1915]), notably from a topographical angle. He argued that the day’s residues are part of the preconscious, but receive the full cathexis necessary for the dream-work from the unconscious. He returned to this group of hypotheses in the *Introductory Lectures on Psychoanalysis* (1916–1917 [1915–1917]).

Thereafter, the question of day’s residues was paid scant attention by Freud, but inasmuch as the notion has a bearing on perception, memory, reality testing, hallucination, and other issues, it remains central. Meanwhile, psychoanalytic technique and practice continue to make use of it on a daily basis.

ROGER PERRON

*See also:* *Delusions and Dreams in Jensen’s “Gradiva”*; Dream; Irma’s injection, dream of; Latent; Manifest; Secondary revision.

### **Bibliography**

Freud, Sigmund. (1900). The interpretation of dreams. *SE*, 4–5: 1–625.

———. (1916–1917f [1915]). A metaphysical supplement to the theory of dreams. *SE*, 14: 217–235.

———. (1916–1917a [1915–1917]). Introductory lectures on psychoanalysis. *SE*: 15–16.

### **Further Reading**

Langs, Robert J. (1971). Day residues, recall residues, dreams: reality and the psyche. *Journal of the American Psychoanalytic Association*, 19, 499–523.

Luborsky, Lester, and Shevrin, Howard. (1956). Dreams and day-residues: a study of the Poetzl observation. *Bulletin of the Menninger Clinic*, 20, 135–148.

---

## **DEAD MOTHER COMPLEX**

The complex of the dead mother was described by André Green in 1980. Evidence of it emerges during the transference, so it is often not identifiable when analysis is first requested. It is manifested especially by a “transference depression,” a repetition of an infantile

depression that is often not capable of being recalled. The essential characteristic of this depression is that it occurs in the presence of an object that itself is absorbed in mourning. The causes of this mourning can be many, and are not admitted by the maternal object. They are therefore, for the most part, hypothetically deduced through the analysis, with more or less certainty.

The main observable consequence on the level of the counter-transference is insight into a cold, hard, unfeeling kernel at the heart of the transference. This is the result of a brutal maternal decathexis that the child is unable to understand and that turns his psychic world upside down. After vain attempts at reparation, feelings of impotence became dominant. Complex defenses are then set up which associate a mirror-representation of the disinvestment in the maternal object with an unconscious identification with the dead mother. The result of this is the psychic murder of the object, which takes place without any hatred. The maternal affliction prohibits any aggressive expression, which would risk augmenting the maternal detachment. On the one hand, the pattern of object relations is punctured, while on the other, peripheral cathexes are clung to at the edge of this hole. Silent destructiveness does not allow the subject to reestablish an object relation capable of overcoming the conflict and opening the way to connections that would strengthen it, or else definitive adjustments serve only as a shield that prevents access to the kernel of the conflict. The only thing that endures is a dull psychic pain, characterized especially by an incapacity to cathect closely with any object having anything to do with affects. Hatred is as impossible as love, and it is impossible to receive without feeling obliged to give back, so as not to owe anything, even masochistic pleasure. The dead mother is omnipresent, but without being represented, and seems to have seized the subject, making him captive of his mourning for her.

This clinical picture develops against the background of the child’s inability to grasp the reasons for it. Important measures of infantile depression are the loss of meaning, and the feeling of inability to repair the mourned object, to awaken the lost desire. Sometimes significant rationalizations displace the source of the conflict onto the external world, the mother’s desire becoming inaccessible compared to what the child believes he has observed. The child then blames a failure of subjective omnipotence in relationships,

leading, by compensation, to a reinforcement of omnipotence in areas less directly connected with the primary object.

An oedipal analysis of pregenital fixations and unconscious guilt is of no use in finding a way to move past this situation, insofar as analysis is not centered on the configuration of the complex of the dead mother. For the mother is not directly identifiable in the discourse of the patient. She only appears to the extent that the analytic situation succeeds in drawing out evidence of her silent presence without being able to find her in this absence where even indirect signs of her existence are missing.

Repression has erased the memory trace of her touch, of contact with her, and of the child's cathexis with her before the occurrence of his mourning for her, which put a sudden end to this forgotten relation. This is a repression that returns to bury her alive, even demolishing everything, including a tomb, that would mark her past existence. Winnicottian holding has collapsed in this situation, because the object has been encysted, with no trace of it left. The identification has been with the vacuum left behind by the disinvestment. The absence of all meaningful reference points cannot be too strongly emphasized. Since the modification of the maternal attitude seemed to be inexplicable, it led in turn to all sorts of questions which arouse a feeling of guilt, and these in turn are aggravated by secondary defenses and displaced onto elements that have been annexed for that purpose.

In effect, attempts to block problems not governed by repression of this untenable situation prompt some significant reactions. Their purposes are: (1) To keep the ego alive through secondary hatred of the object, by the frenetic, but unquenchable, search for pleasures, or through the headlong search for a possible meaning to the displacements that have been made; (2) To reanimate the dead mother, interest her, distract her, seduce her, give her back the taste for life, breathing into her by any means possible, including the most artificial, a joy of being alive; and (3) To compete with the object of mourning in a precocious triangulation.

The dead mother complex, as a powerful and intense element, naturally draws to it other components of psychic life, and is closely tied to its most important systems. Consequently the fantasy of the primal scene attempts to make intelligible the competitive relations with the hypothetical object of sudden mourning, and to reawaken the pain of being de-

cathected, by highlighting whatever recalls the primal scene, and often in an apocalyptic way, through projective identification. The catastrophe thus envelops and retaliates against the maternal object, which shifts between indifference and terror. It is frequently the case that the father is the object of a precocious investment in an Oedipus complex that is rushed into for this very occasion, but lacking in its normal attributes. This variant complex brings with it not so much castration anxiety, but a feeling of impotent rage and paralysis, helpless against the violence that follows action against a supposed rival. The result is often an intensified feeling of emptiness, repeating and amplifying the most deleterious effects at the heart of the conflict.

On the bases of these clinical observations, André Green hypothesized a destiny of the primary object as a framing structure for the ego, hiding the negative hallucination of the mother. The dead mother complex demonstrates the failure of this process, forcing its representations into a painful vacuity, and obstructing their capacity to bind together in any preconscious thought pattern. The dead mother complex opposes a "hot" castration anxiety, linked to the vicissitudes of object relations, which can be threatened with corporal mutilation, to a "cold" anxiety, which is linked with losses suffered on the narcissistic level (negative hallucination, flat psychosis, dull mourning), resulting in the clinical treatment of negativity.

ANDRÉ GREEN

*See also:* France; Intergenerational; Oedipus complex, early; Transference depression; Work (as a psychoanalytic notion).

### **Bibliography**

- Green, André. (2001). *The dead mother*. In his *Life narcissism/death narcissism* (Andrew Weller, Trans.). London, New York: Free Associations Books.
- Kohon, Gregorio. (Ed.). (1999). *The dead mother. The work of André Green*. London, New York: Routledge.

---

## **DEATH AND PSYCHOANALYSIS**

Our own death cannot be represented, which is obvious since it would require a self-observing consciousness that disappears with death and therefore cannot perceive the death. Any anticipation of our own death as nothingness is therefore impossible. For

Freud, this philosophical evidence was reflected in his remarks that “our unconscious . . . does not believe in its own death; it behaves as if it were immortal” (1915b, p. 296) and “it is indeed impossible to imagine our own death; and whenever we attempt to do so we can perceive that we are in fact still present as spectators” (1915b, p. 289). These two propositions should not be confused. The second is a logical statement, since in the absence of existence there is no consciousness, while the first refers to the make-up of the unconscious system and especially the fact that it ignores time and its passage, and more radically, negation.

The inability to represent one’s own death does not imply that we fail to suffer about the certainty of death. Anxiety about death occupies a central place in our lives, and ultimately it is this that superego anxiety and castration anxiety refer to. Moreover, death is represented in dreams and symbols. Departures and muteness, or the ability to hide from others are oneiric representations of death. Among the typical dream types Freud mentions in *The Interpretation of Dreams* (1900a) is the dream of the death of loved ones.

Perception about the death of the other is a central element in obsessive neurotics. Freud wrote, “these neurotics need the help of the possibility of death chiefly in order that it may act as a solution of conflicts they have left unsolved” (1909d, p. 236). By suppressing an element of indecision, death would allow resolution, but death, and the possibility of escaping it through superstitious magical activities, is associated with their unconscious hatred in the conflict of ambivalence. The idea of death offers a solution in obsessive neurosis, but it is also, for everyone, a value that, by establishing a contrast, exalts the value of life. Freud demonstrates this in relation to transience (1916a [1915]), but he also emphasizes it in relation to the risk of death: “Life is impoverished, it loses in interest, when the highest stake in the game of living, life itself, may not be risked” (1915b, p. 290).

Beyond the impossible representation of one’s own demise, there is the question of death as enigma, similar to birth, as the end mirrors the beginning. Freud questions primitive man’s attitude to death (1912–1913a) by distinguishing between the triumph before the corpse of the enemy and the pain experienced in the loss of a loved one. Certainly, in these cases identification could lead primitive man to also consider his own death. But Freud introduced an additional idea,

that of the ambivalence that would lead to suffering and relief, and considered it to be the root not of the representation of death but of the fact that the disturbance caused by it might have led men to think: “What released the spirit of enquiry in man was not the intellectual enigma, and not every death, but the conflict of feeling at the death of loved yet alien and hated persons” (1915b, 293).

As for children, Freud also felt that the origin of the activity, if not of thought, at least of research, was found in the desire for affection (preserving the love of one’s parents without sharing it with younger siblings). In contrast he does not appear to have considered that for children the representation of death and, in particular, their own death, might have constituted an enigma and encouragement for reflection. “Children”, he wrote, “know nothing of the horrors of corruption, of freezing in the ice-cold grave, of the terrors of eternal nothingness—ideas which grown-up people find it so hard to tolerate, as is proved by all the myths of a future life” (1900a, p. 254). On the contrary, we can consider that the theories, or myths, that the child creates to explain the origin of life also treat its end, and that both preoccupations are inseparable.

These theories raise the question of the causality of death. We know that the adult, rather than seeing death as an inevitable destiny, will consider the immediate causes, or even look for those responsible (1915b). The child, in a similar position, does not hesitate to make death the result of murder. For here the relationship to death retains its original form, that is, the impulse to kill repressed by an important moral injunction, “Thou shalt not kill.” However, there is one area where this impulse can be given free rein: literary fiction, which provides the pleasure of remaining alive and the certainty that we have not killed anyone. “In the realm of fiction we find the plurality of lives which we need” (1915b, p. 291). The fact that so-called “crime” writing has always enjoyed such success attests, as surely as the existence of a moral imperative, to the existence and persistence of this impulse to murder and the enigma contained in this return to death, here couched in playful terms (Mijolla-Mellor, 1995).

SOPHIE DE MIJOLLA-MELLOR

See also: *Beyond the Pleasure Principle*; Castration complex; Certainty; Death instinct (Thanatos); Estrangement; “Mourning and Melancholia”; “On Transience”;

Phantom; Suicidal behavior; Suicide; “Thoughts for the Times on War and Death”; “Uncanny, The”.

### **Bibliography**

Freud, Sigmund. (1900a). The interpretation of dreams, part I. *SE*, 4–5.

———. (1912–1913a). Totem and taboo. *SE*, 13: 1–161.

———. (1915b). Thoughts for the times on war and death. *SE*, 14: 273–300.

Mijolla-Mellor, Sophie de. (1995). *Meurtre familial. Approche psychanalytique d'Agatha Christie*. Paris: Dunod.

M'Uzan, Michel de. (1977). *De l'art à la mort*. Paris: Gallimard.

### **Further Reading**

Laplanche, Jean. (1976). *Life and death in psychoanalysis* (Jeffrey Mehler, Trans.). Baltimore, MD: Johns Hopkins University Press.

---

**DEATH DRIVE.** See *Death instinct (Thanatos)*

---

## **DEATH INSTINCT (THANATOS)**

The death instinct or death drive is the force that makes living creatures strive for an inorganic state. It does not appear in isolation; its effect becomes apparent, in particular through the repetition compulsions, when a part of it is connected with Eros. Its tendency to return living creatures to the earlier inorganic state is a component of all the drives. In this combined form, its main impetus is toward dissolution, unbinding, and dissociation. In its pure form, silent within the psychic apparatus, it is subjugated by the libido to some extent and thus deflected to the outside world through the musculature in the drive for destruction and mastery or the will to power: this is sadism proper; the part that remains “inside” is primary erogenous masochism.

Having put forward, particularly in “Instincts and Their Vicissitudes” (1915c), a dualism in which the sexual drives conflict with the ego drives, in *Beyond the Pleasure Principle* (1920g), Freud introduced the concept of the death drive as a negative term in opposition

to the life drive: “The opposition between the ego or death instincts and the sexual or life instincts would then cease to hold and the compulsion to repeat would no longer possess the importance we have ascribed to it” (p. 44).

The death instinct was Freud’s attempt to explain this repetition compulsion that overrides the pleasure principle, whether in post-traumatic dreams, certain compulsive children’s games (such as the “fort-da” game), or indeed in analysts’ resistances to the treatment (the transference). He observed that “*the aim of all life is death*,” “*inanimate things existed before living ones*” and that “*everything living dies for internal reasons*” (p. 38). Drawing on August Weismann’s differentiation of soma from germ-plasma, Freud went on to draw “a sharp distinction between ego-instincts, which we equated with death instincts, and sexual instincts, which we equated with life instincts” (pp. 52–53). He thus continued to adhere to the dualistic concept of the drives: “even more definitely dualistic than before—now that we describe the opposition as being not between ego instincts and sexual instincts but between life instincts and death instincts” (p. 53).

Freud found support for his arguments in Fechner’s stability principle: “The dominating tendency of mental life . . . is the effort to reduce, to keep constant or to remove internal tension due to stimuli . . . a tendency which finds expression in the pleasure principle; and our recognition of this fact is one of our strongest reasons for believing in the existence of death instincts” (p. 55–56).

In 1924, Freud drew a clear distinction between three principles: “The Nirvana principle [Barbara Low’s term], belonging as it does to the death instinct, has undergone a modification in living organisms through which it has become the pleasure principle . . . the *pleasure* principle represents the demands of the libido; and the modification of the latter principle, the *reality* principle, represents the influence of the external world” (1924c, p. 160). Although Freud recognized the speculative nature of his final drive theory, he continued to adhere to it throughout the rest of his work.

The source of the death drive lies in the cathexis of bodily zones that can generate afferent excitations for the psyche then; this certainly involves tension in the musculature determined by a biological urge. Its locus is in the id, then later under the influence of

the ego, as well as in the superego, where it functions to restrict libidization. In melancholia, “a pure culture of the death instinct” (1923b, p. 53) governs the superego, such that the ego can impel the subject towards death.

The energy of this urge is fairly resistant to shaping, diversion, or displacement and it manifests in subtle but powerful ways. The operation of this almost invisible energy has been described as a “work of the negative” (André Green). Its object is the implementing organ—the musculature—that enables the aim to be fulfilled. Paradoxically, the libido, subject to restraint by the *destrudo* (Edoardo Weiss’s term), and leading to primary masochism and sadism, is the object of the death drive here. According to Freud’s descriptions, its goal is dissociation, regression, or even dissolution. While leading organic life back to an inorganic state is the final stage, “the purpose of the death drive is to fulfil as far as is possible a *disobjectalising function* by means of unbinding” (Green, p. 85). It is therefore an entropic process in the strict sense.

After explaining the notion of the death instinct in *Beyond the Pleasure Principle*, Freud returned to it a number of times in his later works. He mentioned it in *Group Psychology and the Analysis of the Ego* (1921c) as the source of aggression and hostility between people and in “The Libido Theory” (1923a), and then developed the theory in *The Ego and the Id* (1923b), especially in the chapters on “the two classes of instincts” and “the dependent relationships of the ego.” In this work, he connected his new drive theory with the structural theory that he had just expounded.

Then, following a dispute with Fritz Wittels, who jumped to a hasty conclusion concerning a connection between the death of Freud’s daughter Sophie (January 1920) and the emergence of the concept of the death drive (a claim that is still being debated today—cf. Grubrich-Simitis), Freud returned to this concept in “The Economic Problem of Masochism” (1924c), in which he posited primary masochism both as evidence and as a vestige of the conjunction between the death drive and Eros. He thus elucidated the negative therapeutic reaction and the concept of unconscious guilt and indicated that “moral masochism becomes a classical piece of evidence for the existence of fusion of instinct. Its danger lies in the fact that it originates from the death instinct and corresponds to the part of

that instinct which has escaped being turned outwards as an instinct of destruction” (p. 170).

In his short article on “Negation” (1925h), Freud explained: “Affirmation—as a substitute for uniting—belongs to Eros; negation—the successor to expulsion—belongs to the instinct of destruction” (p. 239). He returned to this subject in *Civilization and Its Discontents* (1930a [1929]), in his letter to Albert Einstein (1933b [1932]) and finally in the thirty-second of the *New Introductory Lectures* (1933a [1932]), in which he discussed anxiety in connection with the life of the drives.

For Melanie Klein, a firm advocate of the existence of the death drive, psychic conflict is never a conflict between the ego and the drives but always between the life drive and the death drive. Anxiety is the immediate response to the endopsychic perception of the death drive. For Jacques Lacan, the death drive as something beyond the pleasure principle forms the best starting-point for introducing his concept of the “Real,” in connection with the Imaginary and the Symbolic. He links to this the lethal dimension inherent in desire and *jouissance* and makes the death drive “the necessary condition for the natural phenomenon of the instinct in entropy to be taken up at the level of the person, so that it may take on the value of an oriented instinct and is significant for the system insofar as the latter as a whole is situated in an ethical dimension” (1959–1960/1992, p. 204).

Toward the end of his life, Freud recognized that “the dualistic theory according to which an instinct of death or of destruction or aggression claims equal rights as a partner with Eros as manifested in the libido, has found little sympathy and has not really been accepted even among psychoanalysts” (1937, p. 244). Its detractors include authors such as Michel Fain (1971), who regard the concept of the death drive as the result of Freud’s speculations on matters that could for the most part be explained without it—for example by the mechanism of “reversal into its opposite” (1915c, p. 126). Others have objected to the theory of the death drive either because this would mean that psychic conflict, the cornerstone of psychoanalysis, could no longer be the expression of lived experience alone, since the death drive is “evidently innate, intrapsychic from the outset, and not secondarily internalized” (Nacht), or because “this drive restricts the field in which conflicts can be elaborated both internally and externally; it introduces a fatalism into

the gradual progression of the treatment and brings out the negative therapeutic reaction instead of a relational problem between analyst and analysand” (Nicolaidis). Yet others have taken more interest in Freud’s methodology and are surprised at the “quality of a foreign body—within psychoanalytic theory—that characterizes the conflict between Eros and the death drive [which] emerges here from the use of dialectical procedures in which Freud is not well versed” (Denis).

By contrast, other authors, such as Melanie Klein, Jacques Lacan, and André Green, consider this concept of the death drive as further evidence of Freud’s scientific rigor, as he demonstrates his willingness to rework his previous drive theory to take account of clinical facts and hypotheses that do not accord with it. Furthermore, studies based on the treatment of psychotic subjects, particularly by post-Kleinians, seem to have reinforced the theory of the prevalence of the death drive in the psychic apparatus of these patients, as something that constantly tears at the fabric of their representations and undermines their attempts to establish an apparatus for thinking thoughts (Wilfred Bion).

PIERRE DELION

*See also:* Alienation; Anxiety; Drive/instinct; *Ego and the Id*; *The*; Envy; Envy and Gratitude; Eros; *Freud: Living and Dying*; Life instinct (Eros); Masochism; Narcissistic neurosis; Negative, work of the; Negative therapeutic reaction; Negative transference; Nirvana; Orgasm; Phobic neurosis; Pictogram; Projective identification; Racism, antisemitism, and psychoanalysis; Repetition compulsion; Sadism; Self-hatred; Trauma; “Why War?”

### Bibliography

- Denis, Paul. (1997). *Emprise et satisfaction, les deux formants de la pulsion*. Paris: Presses universitaires de France.
- Fain, Michel. (1971). Prélude à la vie fantasmatique. *Revue Française de Psychanalyse*, 35, 2–3, 291–364.
- Freud, Sigmund. (1915c). Instincts and their vicissitudes. *SE*, 14, 109–140.
- . (1920g). Beyond the pleasure principle. *SE*, 18, 1–64.
- . (1921c). Group psychology and the analysis of the ego. *SE*, 18, 65–143.
- . (1923a). The libido theory. *SE*, 18, 255–259.
- . (1923b). The ego and the id. *SE*, 19, 1–66.
- . (1924c). The economic problem of masochism. *SE*, 19, 155–170.
- . (1925h). Negation. *SE*, 19, 233–239.
- . (1930a [1929]). Civilization and its discontents. *SE*, 21, 57–145.
- . (1933a [1932]). New introductory lectures on psycho-analysis. *SE*, 22, 1–182.
- . (1933b [1932]). Why war? (Einstein and Freud). *SE*, 22, 195–215.
- . (1937c). Analysis terminable and interminable. *SE*, 23, 209–253.
- Green, André. (1999). The death drive, negative narcissism and the disobjectalising function. In *The work of the negative* (pp. 81–88) (A. Weller, Trans.). London: Free Association Books.
- Grubrich-Simitis, Ilse. (1996). *Back to Freud’s texts. Making silent documents speak* (Philip Slotkin, Trans.). New Haven: Yale University Press. (Original work published 1993)
- Lacan, Jacques. (1992). *The seminar of Jacques Lacan: Book VII. The ethics of psychoanalysis* (J.-A. Miller, Ed., and D. Porter, Trans.). London: Routledge. (Original work published 1959–1960)
- Nacht, Sacha. (1938). *Le Masochisme, Étude historique, clinique, psychogénique et thérapeutique*. Paris: Denoël.
- Nicolaidis, Nicos. (1993). La Force perceptive de la représentation de la pulsion. Paris: Presses universitaires de France.

### Further Reading

- Eissler, Kurt R. (1971) Death drive, ambivalence, and narcissism. *Psychoanalytic Study of the Child*, 26, 25–78.
- Feldman, Michael. (2000). Some views on the manifestation of death instinct in clinical. *International Journal of Psychoanalysis*, 81, 53–66.
- Grotstein, James. (2000). Some considerations of hate & reconsideration of death instinct. *Psychoanalytic Inquiry*, 20, 462–480.
- Segal, Hanna. (1993). On the clinical usefulness of the concept of death instinct. *International Journal of Psychoanalysis*, 74, 55–62.

---

## DECATHEXIS

Decathexis describes both the action and the result of withdrawing psychic energy—usually libido—away



from where it had been attached to a psychic formation, a bodily phenomenon, or an object.

The idea of decathexis, or withdrawal of cathexis, is linked to the notion of psychic energy and occurs very early on in Freud's work, although the term itself or its equivalents are not explicitly used. As early as "The Neuro-Psychoses of Defence" (1894a), Freud outlines certain mechanisms for repressing representations when he writes that we have "an approximate fulfillment of the task if the ego succeeds in *turning this powerful idea into a weak one*, in robbing it of the affect—the sum of excitation—with which it is loaded" (1894a, p. 48). In fact the notion of decathexis first appears as a means of repression in his work on the paranoia of Justice Schreber: "It is quite possible that a detachment of the libido is the essential and regular mechanism of every repression" (1911c [1910], p. 71). But the important role eventually attributed to energy in the very constitution of the psyche would make decathexis a central notion, independent of the mechanism of repression. The nature of decathected mental structures or objects, the more or less massive modalities of the decathexis, and the fate of the withdrawn energy, all would have serious consequences. As Freud writes: "the liberated libido will be kept in suspension within his mind, and will there give rise to tensions and color his mood" (1911c [1910], p. 72), until it finds another attachment. In the case of paranoia it will hypercathect the ego. In "Mourning and Melancholia" (1916–17f [1915]), Freud studied the progressive withdrawal of cathexis from the lost object, this being necessary for the reality of loss to be finally acceptable.

PAUL DENIS

*See also:* Boredom; Cathexis; Counter-investment; Dead mother complex; Dismantling; Fusion/defusion of the instincts. Repression; Sleep/wakefulness; Transference depression.

### **Bibliography**

- Freud, Sigmund. (1894a). The neuro-psychoses of defence. *SE*, 3 : 41–61.
- . (1911c [1910]). Psycho-analytic notes on an autobiographical account of a case of paranoia (dementia paranoides). *SE*, 12: 1–82.
- . (1914c). On narcissism: an introduction. *SE*, 14: 67–102.

———. (1915e). Psycho-analytic notes on an autobiographical account of a case of paranoia (dementia paranoides). *SE*, 12: 1–82.

———. (1916–17f [1915]). A metapsychological supplement to the theory of dreams. *SE*, 14: 217–235.

Rouart, Julien. (1967). Les notions d'investissement et de contre-investissement à travers l'évolution des idées freudiennes. Colloque de la Société psychanalytique de Paris, Paris, 1965. *Revue Française de Psychanalyse*, 31, (2), 193–213.

## **DEFENSE**

The term "defense" refers to all the techniques deployed by the ego in conflicts that have the potential to lead to neurosis. In the sense in which Freud first used the term, defenses are unconscious because they stem from a conflict between the drive and the ego or between a perception or representation (memory, fantasy, etc.) and moral imperatives. The function of the defenses is thus to support and maintain a state of psychic stability by avoiding anxiety and unpleasure. The concept of defense was broadened somewhat when Freud attributed an important role to the reality principle and to the superego. Melanie Klein then formed the more radical view that the defenses exist within an archaic ego.

In his letter to Wilhelm Fliess dated May 21, 1894, and concerning his interpretation of the neuroses, Freud introduced the concept of defense in connection with the notion of psychic conflict: "What is warded off is always sexuality" (1985c [1887–1904], p. 75). In reference to the emergence of anxiety, he argued that sexual tension turned into anxiety when it was not psychically elaborated and thereby transformed into affect. Freud attributed this phenomenon to, among other things, a repression of psychic sexuality, that is, to a defense. In his letter to Fliess dated May 30, 1896, he linked repression with defense by emphasizing, "Surplus of sexuality alone is not enough to cause repression; the cooperation of *defense* is necessary" (p. 188).

In "Further Remarks on the Neuro-psychoses of Defence" (1896b), Freud deepened his analysis of defense as arising from the conflict between the drive and the ego, the conscious agent of repression. Freud considered the defense as the "nuclear point" (p. 162) in the psychic mechanism of the neuroses. With regard to how symptoms arise, he detailed more clearly how

the unconscious psychic mechanism of defense resulted from the conflict of a representation with moral imperatives.

In “Repression” (1915d), Freud emphasized that the mechanism of defense “cannot arise until a sharp cleavage has occurred between conscious and unconscious mental activity—that *the essence of repression lies simply in turning something away, and keeping it at a distance, from the conscious*” (p. 147).

Much later (1926d), Freud observed that after he had abandoned the term “defensive process” for thirty years and replaced it with the term “repression” (without clearly explaining the possible connection between these two concepts) (p. 163), there were “good enough grounds for re-introducing the old concept of *defence*” (p. 164). In fact, Freud had never entirely abandoned the term, since he discussed the denial of castration (albeit initially without using the term “denial” [*Verleugnung*]) in relation to children’s theories of sexuality (1908c) and little Hans (1909b). Freud discussed denial more explicitly with regard to fetishism (1927e), a concept that plays a pivotal role in his work, and in his paper on negation (1925h), which he defined as representing “a kind of intellectual acceptance of the repressed, while at the same time what is essential to the repression persists” (p. 236). Thus, “the content of a repressed image or idea can make its way into consciousness, on condition that it is *negated*” (p. 235). Freud also discussed sublimation, a concept that was already present in “Leonardo da Vinci and a memory of his childhood” (1910c) and that reappeared in *The Ego and the Id* (1923b) in connection with the ego energy, which Freud stipulated as involving “a desexualisation—a kind of sublimation” (p. 30).

These distinctions, which predate *Inhibitions, Symptoms, and Anxiety* (1926d), were later probably instrumental in Freud’s ascribing a more important function to this “old concept of *defence*” and restricting the role of repression, to the extent that he suggested making defense “a general designation for all the techniques which the ego makes use of in conflicts which may lead to a neurosis, while we retain the word ‘repression’ for the special method of defence which the line of approach taken by our investigations made us better acquainted with in the first instance” (p. 163).

In furthering her father’s work, Anna Freud sought to develop a theory that would demonstrate how the

three agencies of the structural theory functioned. In particular, she described how the ego becomes “suspicious” in the face of the onslaught of the drives and “proceeds to counter-attack and to invade the territory of the id. Its purpose is to put the instincts permanently out of action by means of appropriate defensive measures, designed to secure its own boundaries” (1936, p. 8). Thus, Anna Freud’s account of psychic functioning attributes some force to the adaptive functions of the ego.

Her works were often quoted by the ego-psychology movement that formed in the 1950s in the United States. Within the ego-psychology movement, Heinz Hartmann developed his theory of the ego in connection with the problem of adaptation, which he described in terms of the development of a “conflict-free ego sphere” (1958, p. 3) or autonomous ego. In this movement, psychic functioning in general is considered in terms of defense and its quest for equilibrium.

Along similar lines, René Spitz, who located the first defense in the emergence of the second organizer (the so-called eight-month or stranger anxiety), explained that these defenses initially “serve primarily adaptation rather than defense in the strict sense of the term” (p. 164). It is when the object is established and ideation starts that their function changes. With the fusion of the aggressive and libidinal drives, some defense mechanisms, in particular identification, “acquire the function that they will serve in the adult” (p. 164).

When Anna Freud was publishing her first psychoanalytic works, Melanie Klein, while breaking with Freudian orthodoxy by asserting that the agencies of the psyche begin functioning much earlier, introduced a perspective that restored to anxiety and psychic conflict a fundamental role in psychic functioning. Drawing on Freud’s second theory of the drives, she attributed a central role to the death drive and the conflicts between love and hatred. She thus developed her ideas on early defense mechanisms that were already present, in her view, in the earliest months of life during the paranoid-schizoid position.

The concept of defense, as it has developed and been used since Freud, has become somewhat common in both clinical psychology and psychoanalysis. There it refers either to a relatively conscious behavior that rejects psychic reality (a definition that makes the

concept more akin to the concept of resistance) or to a psychic impulse that seeks to avoid anxiety and unpleasure in the quest to adapt and achieve a state of equilibrium. As a result, the function of defense as a mechanism necessary for psychic growth is often overlooked.

ELSA SCHMID-KITSIKIS

*See also:* Actual neurosis/defense neurosis; Autistic defenses; Conflict; Defense mechanisms; Ego; *Ego and the Mechanisms of Defense, The*; Manic defenses; Narcissistic defenses; Negation; Neurotic defenses; Paranoid-schizoid position; Psychoneurosis (or neuro-psychosis) of defense; Psychotic defenses; Repression; “Splitting of the Ego in the Process of Defence, The.”

### Bibliography

- Freud, Anna. (1936). *The ego and the mechanisms of defense*. New York: International Universities Press.
- Freud, Sigmund. (1896b). Further remarks on the neuro-psychoses of defence. *SE*, 3, 157–185.
- . (1908c). On the sexual theories of children. *SE*, 9, 205–226.
- . (1909b). Analysis of a phobia in a five-year-old boy. *SE*, 10, 1–149.
- . (1910c). Leonardo da Vinci and a memory of his childhood. *SE*, 11, 57–137.
- . (1915d). Repression. *SE*, 14, 141–158.
- . (1923b). The ego and the id. *SE*, 19, 1–66.
- . (1925h). Negation. *SE*, 19, 233–239.
- . (1926d). Inhibitions, symptoms, and anxiety. *SE*, 20, 75–172.
- . (1927e). Fetishism. *SE*, 21, 147–157.
- . (1985c [1887–1904]). *The complete letters of Sigmund Freud to Wilhelm Fliess, 1887–1904* (Jeffrey M. Masson, Trans.). Cambridge, MA: Harvard University Press, 1985.
- Hartmann, Heinz. (1958). *Ego psychology and the problem of adaptation*. New York: International Universities Press. (Original work published 1939)
- Klein, Melanie. (1975). Notes on some schizoid mechanisms. (pp. 1–24) In *The writings of Melanie Klein*. London: Hogarth Press. (Original work published 1946)
- Le Guen, Claude; Anargyros-Klinger, Annie; Bauduin, Andrée; et al. (1986). Le refoulement (les défenses). *Revue Française de Psychanalyse*, 50, 1, 23–370.

Spitz, René A., in collaboration with W. Godfrey Cobliner. (1965). *The first year of life: A psychoanalytic study of normal and deviant development of object relations*. New York: International Universities Press.

### Further Reading

- Blum, Harold, (Ed.). (1987). *Defense and Resistance: Historical Perspectives and Current Concepts*, New York: International Universities Press.
- Brenner, Charles. (1981). Defense and defense mechanisms. *Psychoanalytic Quarterly*, 50, 557–569.
- Gray, Paul. (1994). *The ego and the analysis of defense*. Northvale, NJ: Aronson Inc.
- Loewald, Hans. (1952). The problem of defense; the neurotic interpretation of reality. *International Journal of Psychoanalysis*, 33, 444–449.

## DEFENSE MECHANISMS

Defense mechanisms are psychic processes that are generally attributed to the organized ego. They organize and maintain optimal psychic conditions in a way that helps the subject's ego both to confront and avoid anxiety and psychic disturbance. They are therefore among the attempts to work through psychic conflict but if they are deployed in an excessive or inappropriate way they can compromise psychic growth.

There is no clear distinction in Sigmund Freud's work between a defense and a defense mechanism, (the latter referring to the unconscious processes by which the defense operates). The concept of defense first appeared in his article “The Neuro-Psychoses of Defence” (1894a) and was next discussed in “Further Remarks on the Neuro-Psychoses of Defence” (1896b) and “The Aetiology of Hysteria” (1896c). Finally, in the text entitled “Instincts and their Vicissitudes” (1915c), turning against the self and reversal into the opposite were identified as defense mechanisms, in addition to repression and sublimation.

For Freud, the concept of defense refers to the ego's attempts at psychic transformation in response to representations and affects that are painful, intolerable, or unacceptable.

He abandoned the concept of defense for a period in favor of the concept of repression. He then reintroduced it in “Neurotic Mechanisms in Jealousy, Paranoia and Homosexuality” (1922b [1921]). Freud

ascribed a defensive significance to introjection (or identification) and projection by terming them all “neurotic mechanisms.” Then in an addendum to *Inhibitions, Symptoms and Anxiety* (1926d [1925]), he reconsidered this concept in relation to that of repression, suggesting that: “It will be an undoubted advantage, I think, to revert to the old concept of ‘defence,’ provided we employ it explicitly as a general designation for all the techniques which the ego makes use of in conflicts which may lead to a neurosis, while we retain the word ‘repression’ for the special method of defense which the line of approach taken by our investigations made us better acquainted with in the first instance” (p. 163). Freud added that: “further investigations may show that there is an intimate connection between special forms of defense and particular illnesses, as, for instance, between repression and hysteria” (p. 164). By this he meant, more specifically, that the ego protects itself against the tendency towards conflict by means of a counter-cathexis. It was this counter-cathexis that came to represent the supreme essence of the defense mechanisms.

This idea was taken up by Heinz Hartmann (1950) in the context of his theory of the autonomous functions of the ego. He argued that once the energy of the counter-cathexis had been withdrawn from the tendency that caused the conflict, it was neutralized. For him, the autonomous processes (organization, cathexis, delay) can be the precursors of defense mechanisms. In general, neurotic defense mechanisms constitute an exaggeration or a distortion of regulating and adaptive mechanisms.

With strong support from the ego-psychology movement in her studies on ego functions, Anna Freud listed and described the ego’s defense mechanisms. For her, “every vicissitude to which the instincts are liable has its origin in some ego-activity. Were it not for the intervention of the ego or of those external forces which the ego represents, every instinct would know only one fate—that of gratification” (1937, p. 47). To the nine defense mechanisms that she identified: “regression, repression, reaction-formation, isolation, undoing, projection, introjection, turning against the self and reversal,” she suggested that, “we must add a tenth, which pertains rather to the study of the normal than to that of neurosis: sublimation, or displacement of instinctual aims” (p. 47).

Finally, for adherents of the Kleinian school, the defense mechanisms take a different form in a struc-

tured ego from the one they assume in a primitive, unstructured ego (or an undifferentiated id-ego). The defenses become modes of mental functioning. For Susan Isaacs (1948), all mental mechanisms are linked to fantasies, such as devouring, absorbing, or rejecting. Melanie Klein herself (1952, 1958) principally identified the following primitive defenses: splitting, idealization, projective identification and manic defenses.

The terms “defense” and “defense mechanism” are still used interchangeably today, which suggests a degree of confusion between a descriptive approach to the concept of defense and an approach based on the analysis of psychic adaptations from an economic viewpoint.

ELSA SCHMID-KITSIKIS

*See also:* Defense.

### **Bibliography**

- Benassy, Maurice. (1969). Le moi et ses mécanismes de défense: Étude théorique. In *La théorie psychanalytique*. Paris: Presses Universitaires de France.
- Freud, Anna. (1936). *The ego and the mechanisms of defence*. New York: International Universities Press.
- Freud, Sigmund. (1926d [1925]). Inhibitions, symptoms and anxiety. *SE*, 20: 75–172.
- Hartmann, Heinz. (1950). Comments on the psychoanalytic theory of the ego. *Psychoanalytic Study of the Child*, 5, 74–96.
- Isaacs, Susan. (1952). On the nature and function of phantasy. In M. Klein, P. Heimann, S. Isaacs and J. Riviere (Eds.), *Developments in psycho-analysis* (p. 67–121). (Reprinted from *International Journal of Psychoanalysis*, 29 (1948), 73–97.)
- Klein, Melanie. (1952). Some theoretical conclusions regarding the emotional life of the infant. In *Envy and gratitude and other works, 1946–1963* (pp. 61–93). London: Hogarth, 1975.
- . (1958). On the development of mental functioning. In *Envy and gratitude and other works, 1946–1963*. (pp. 236–246). London: Hogarth, 1975.

---

## **DEFERRED ACTION**

This notion is important to any understanding of the psychoanalytic conception of time. It implies a complex and reciprocal relationship between a significant

event and its later reinvestment with meaning, a reinvestment that lends it a new psychic efficacy.

It was the French reading and translation of Freud that brought out the import of “*nachträglich*” and “*Nachträglichkeit*,” terms which had not hitherto been consistently translated into either French or English.

The index of Freud’s *Gesammelte Werke* has no entry for either *nachträglich* or *Nachträglichkeit*, and perusal of the indexes of the works of Freud’s chief successors garners similarly negative results. It was Jacques Lacan who first drew attention to this notion, defining it in a precise if narrow way (1953, p. 48). Lacan did not consider the broader implications of the concept of *Nachträglichkeit* in Freud’s work, concerning himself solely with its occurrence in connection with the “Wolf Man” case (1918b [1914]) and ignoring its use in the 1895–1900 period. It fell to Jean-Bertrand Pontalis and Jean Laplanche to point up the overall importance of the concept, first in “Fantasy and the Origins of Sexuality” (1964) and then in *The Language of Psycho-Analysis* (1967).

First let us consider Freud’s view. He used the terms “*nachträglich*” and “*Nachträglichkeit*” over a good part of his working life—from the period, in fact, of his correspondence with Wilhelm Fliess, through *The Interpretation of Dreams* (1900a), “Little Hans” (1909b), the “Wolf Man” case, and even well beyond. It is thus possible to trace the development of this idea in the general context of his work. It never achieved sufficient conceptual substance, however, for Freud to dedicate an entire paper to it.

The earliest development of the notion may be seen in Freud’s letters to Fliess. The adjective “*nachträglich*,” part of German common usage, is employed by Freud in several ways. In the first place, it has the simple meaning of “additional” or “secondary”; and hence, in a temporal sense, of “later.” A second use implies movement from past time in the direction of the future, while a third implies the opposite, a movement from the future towards the past. The second use, meaning movement from past to future, is very much bound up with the seduction theory: it implies that something is deposited in the individual that will be reactivated later, thus becoming active only at a “second moment.” It is in this regard that the notion of *Nachträglichkeit* is closely correlated with another constant of Freudian thought, the idea that there are always two moments in the constitution of a psychic

trauma: that of the event which leaves its trace and that of the event’s later revival by an internal factor. It is thus easy to understand how the idea of afterwardsness emerged in parallel with the seduction theory, even if it survived the abandonment of that theory. It should be pointed out that for Freud the seduction theory did not contradict a determinism according to which the past governs the present.

Freud never thought that the temporal direction could be reversed. The analogy of a time-bomb serves well here: the initial memory is like a time-bomb set off by a delayed-action mechanism; there is no suggestion of retroactivity. On the other hand, there are a number of passages in Freud where the inverse process occurs, where things are perceived on the first occasion, then understood retroactively. Such passages are relatively few, however.

The fact is that whenever Freud had a choice between a deterministic account proceeding from the past towards the future and a retrospective or hermeneutic conception proceeding from the present in the direction of the past, he almost invariably opted for the former. Thus in his letter to Fliess of October 3, 1897, after recounting an episode in his self-analysis, he makes the following comment: “A severe critic might say of all this that it was retrogressively phantasied and not progressively determined. *Experimenta cruce*s would have to decide against him” (SE 3, p. 263).

So things are not simple. As much as we might wish to find in Freud a dual—perhaps even a contradictory—application of the concept of *Nachträglichkeit*, what we actually find is a highly deterministic one.

Much the same goes for Freud’s theoretical confrontation with Carl Jung: in defending his view of the reality of the “real” primal scene, Freud made a number of concessions but never wavered in his conviction that what comes before determines what comes after. The Freudian idea of *Nachträglichkeit* may by no means be conflated with the Jungian notion of *Zurückphantasieren* (retrospective fantasizing).

To what extent can the concept of afterwardsness enable us to transcend the alternative between, on the one hand, a determinist view that places the entire burden of psychic causality on events of the remotest past, and, on the other hand, a so-called hermeneutic, or even narrativist, approach that reverses the arrow of time, so to speak, and focuses on “resignifications,” or reinvestments with meaning, effected afterwards,

whether in life or during psychoanalytic treatment? When things are framed in this way, it seems impossible to resolve the polarity between childhood events, events pure and simple, and the moment when they are retrieved as meaning, within a history. Yet a way out of this cul-de-sac presents itself if we consider that the childhood event is itself pregnant with meaning—not on the psychophysiological level, but on the level of the interhuman relationship. Even if all our attention is focused on the retroactive temporal direction, it cannot be overlooked that when someone reinterprets their past, that past can never be strictly factual, cannot be a concrete, untransformed “given.” On the contrary, it must contain in immanent fashion something earlier still: a message from the other. A purely hermeneutic approach, meaning that each person interprets their past on the basis of their present, is therefore untenable, for, already deposited in the past, is something that cries out to be deciphered, namely a message from the other person.

Instead of considering only the bipolar temporal vector connecting the child with the adult that the child has become, we need to add a third term, external to the subject, which is the message emanating from the other adult, a message which is imposed on the child and which the child must translate. Indeed it is the idea of “translation” so understood that may be expected to cast a new light on the Freudian concept of *Nachträglichkeit*.

JEAN LAPLANCHE

*See also:* Adolescence; Deferred action and trauma; General theory of seduction; Incompleteness; Infantile, the; Latency period; “Project for a Scientific Psychology, A”; Proton-Pseudos; Puberty; Repression; Seduction scenes; Trauma.

### **Bibliography**

- Freud, Sigmund. (1900a). The interpretation of dreams. *SE*, 4–5.
- . (1909b). Analysis of a phobia in a five-year-old boy. *SE*, 10.
- . (1918b [1914]). From the history of an infantile neurosis. *SE*, 17.
- . (1950a [1887–1902]). *The origins of psycho-analysis: Letters to Wilhelm Fliess, drafts and notes*. (Marie Bonaparte et al., Ed., Eric Mosbacher and James Strachey, Trans.) London: Imago, 1954; partial revised tr. in *SE*, 3.

Lacan, Jacques. (2004). The function and field of speech and language in psychoanalysis. In *Écrits: A selection*. (Bruce Fink, Héloïse Fink, and Russell Grigg, Trans.) New York: Norton. (Original work published 1953)

Laplanche, Jean. (1976). *Life and death in psychoanalysis*. (Jeffrey Mehlman, Trans.). Baltimore: Johns Hopkins University Press. (Original work published 1970)

———. (1998). Temporalité et traduction. In *Le Primat de l'autre*. Paris: Flammarion.

Laplanche, Jean. (1999). Notes on afterwardsness. In *Essays on otherness*. (John Fletcher, Ed., and Luke Thurston, Philip Slotkin, and Leslie Hill, Trans.) London, New York: Routledge. (Original work published 1998)

Laplanche, Jean, and Pontalis, Jean-Bertrand. (1968 [1964]). Fantasy and the origins of sexuality. *International Journal of Psychoanalysis*, 49, 1–18.

Laplanche, Jean, and Pontalis, Jean-Bertrand. (1974 [1967]). *The language of psycho-analysis*. (Donald Nicholson-Smith, Trans.) London: Hogarth/Institute of Psycho-Analysis; New York: Norton.

---

## **DEFERRED ACTION AND TRAUMA**

Freud called upon the notions of deferred action and of trauma to account for how time and causality are organized in a mental life that he conceived of as permeated by sexuality. He argued that an impression inconsequential on its face but unintegrated into the flow of life by reason of its sexual character left mnemonic traces that could be reactivated by later events in the history of the individual. Only then, retroactively, would it acquire a meaning capable of affecting psychic organization.

In his earliest thinking, Freud observed that certain childhood experiences left mnemonic traces of an active albeit unconscious nature. These operated like internal “foreign bodies,” and getting rid of them required that they be made conscious and “abreacted” (discharged by being revealed to the analyst). Such traces were always related to a seduction in early childhood that had not been fully comprehended at the time.

Freud quickly abandoned this theory and replaced it with that of “deferred action” (*Nachträglichkeit*), according to which the child first receives impressions that have an exciting effect, but not a traumatic one, for the child is still sexually undeveloped. When a particular experience occurring after puberty recalls

the earlier one by virtue of some resemblance, the individual reinterprets the early event, which thus acquires a force that it never had initially.

Before long, however, Freud discovered infantile sexuality and could then no longer ground deferred action in a sexual life that developed in two phases. He therefore stipulated that all childhood experiences left a residue, a mnemonic trace, which cried out to be reinterpreted and would be reinterpreted at a later time. This residue or trace always had a sexual character. Freud developed this theory in his account of the “wolf man” case (1918b [1914]). As a two-year-old child, the patient had witnessed his parents engaged in sex without experiencing anything more than an impression of strangeness; only at the age of four did he construct his primal-scene fantasy as a way of accounting for the original perception.

The theory of deferred action is one of the keys to Freud’s metapsychological system. It effectively addresses both the sexual nature of repressed memories and the manner in which time and memory work within the psyche. In Freud’s view, our past—our whole past from birth on—is responsible for what we later become, but there is a sense, too, in which what we become alters what we once were: the present transforms, translates, remolds a past that is still present in us. The individual has contact with the past at every instant of life, but is unable to apprehend that past, which is forever emerging only to be retranslated instantly into other terms.

The notion of deferred action must not, however, be confused with a cognitivist view of how memories are transformed. The cognitivist view sees memories as being reorganized and simplified in natural ways, like material objects moving away from an observer, for example. For psychoanalysis, each moment lived by an individual, if it has a sexual aspect, is experienced as enigmatic, as bearing a residue that poses a question. Such a moment may resonate with a past event with nothing special about it, save for an ever so slightly unsatisfactory and unexplained dimension, which the psyche now remobilizes as desire.

Like the unconscious, and like desire, deferred action is capable of utterly disrupting an individual’s spontaneously created idea of himself in relation to the outside world and to other people. For one, it explodes the notion of causality: not only is the indi-

vidual unable to relate his actions in life to his conscious will, not only is he always disappointed when he obtains what he thought he wanted, because his desire is never satisfied thereby, but also he can never succeed in explaining the present in terms of the past. What went before is never past: it is always present, always ungraspable, always needing to be worked through.

Deferred action is usually associated with trauma. The sight of cruelty can thus be traumatic if it reactivates an infantile sadistic occurrence dating from an early time when cruelty was not disturbing. Likewise, a rape may be traumatic if it revives an infantile sexual wish that was left pending and never erased. Deferred action is also closely tied to repression. If certain later experiences and wishes need to be repressed, it is because at the moment of their occurrence they acquire a strength out of proportion to the circumstances, for they are reinforced by the power of hitherto unassimilated past experiences. The representation of the object of desire then has to be repressed, because, between the first and the second experience, regulatory and prohibitory superstructures have been set up.

Psychoanalysts are divided on how much importance to give to the idea of deferred action. For some, this mechanism comes into play only during a second phase. They believe that some early infantile experiences are traumatizing in themselves and require the deployment of mechanisms more radical than repression, such as splitting or foreclosure. Analysts with this view strive to elicit the memory of such experiences by means of the regression that the analytic situation allows. Pioneers of this approach include Sándor Ferenczi, Wilfred R. Bion, and Donald W. Winnicott.

In contrast, some consider this orientation a simplification of psychoanalysis. In this school of thought, psychical trauma of any kind should not be treated as a quasi-physical event of external origin, imposed by reality. In their eyes, such a trauma is inseparable from deferred action, which they place at the center of a mental life shot through with and determined by sexuality. What the young child seeks, but cannot obtain, is the mother, and later the father—not in respect of what they give, but in respect of what they withhold, what they hide, namely their unconscious wishes. The disparity in sexual maturity between the child and the adult means that whatever the child receives (nourish-

ment, caresses, rebukes) is received in a way that is enigmatic, and hence disturbing, to some degree. The fact is that for the adult, the child is not just a child but also the object whereby the adult gratifies his or her desire. Hence the enigmatic quality to what is given to the child.

It was Jacques Lacan who first reasserted the importance of Freud's concept of deferred action, and Jean Laplanche made it a key concept in his theoretical work.

ODILE LESOURNE

*See also:* Deferred action/afterwardness; Sexual trauma; Trauma

### **Bibliography**

Freud, Sigmund. (1918b [1914]). From the history of an infantile neurosis. *SE*, 17, 1–122.

———. (1950c [1895]). Project for a scientific psychology. *SE*, 1, 281–387.

Freud, Sigmund, and Breuer, Josef. (1893a). On the psychological mechanism of hysterical phenomena: Preliminary communication. *SE*, 2, 1–17.

Lacan, Jacques. (2002). The function and field of speech and language in psychoanalysis. In his *Écrits: A selection* (Bruce Fink, Héloïse Fink, and Russell Grigg, Trans.). New York: Norton. (Original work published 1956)

Laplanche, Jean (1989). *New foundations for psychoanalysis* (David Macey, Trans.). Oxford: Basil Blackwell. (Original work published 1987)

---

**DEFUSION.** *See* Fusion/defusion

---

**DEFUSION OF INSTINCT.** *See* Fusion/defusion of Instinct

---

## **DÉJÀ VU**

*Déjà vu* refers to a state wherein a person feels certain (cognitive judgment) that he or she has previously seen or experienced something that is actually being encountered for the first time. Sigmund Freud believed

the feeling corresponded to the memory of an unconscious daydream.

The term first appeared in a French translation of the *Psychopathology of Everyday Life* (1901b) as part of the discussion of the superstition that can be associated with this mysterious feeling. Freud quotes certain “psychologists,” without specifying who they are. The concept falls squarely within the framework of the paramnesia extensively described by psychiatrists in France, primarily Wigan (1844) and Valentin Magnan (1893), who described systematic delirium accompanied by the illusion of doppelgängers, J. Capgras (1923), who described the illusion of doppelgängers, and Pierre Janet (1905), who described cases of false recognition.

Freud discusses the concept in terms of the psychopathology of everyday life (errors, slips) by removing it from the context of psychosis and by supporting it with his own self-analysis (“rapid sensations of déjà vu that I myself experienced”). He returned to it again, but within the context of therapy, in his “Fausse reconnaissance (*déjà raconté*) in Psycho-Analytic Treatment” (1914a), referring to a central example of the analysis of the Wolf Man. He then provided a partial summary of authors who had discussed the issue, separating them into “believers” (who thought that déjà vu was proof of a previous existence), among whom he includes Pythagoras, and “nonbelievers,” who regard such events as false memories (Wigan, 1860). Freud himself assumes a different position (which he acknowledges sharing with Joseph Grasset, 1904) by believing in the reality of the representative content, but associating this with the reactivation of an older unconscious impression. He returned to the question again in terms of self-analysis at the end of his life in “A Disturbance of Memory on the Acropolis” (1936a).

Déjà vu is one of the “uncanny feelings” that, for Freud, play the role of hallucinations, which become more frequent and systematic during certain mental disturbances. This is the most convincing example of breaching the boundary between the normal and the pathological addressed by Freud. It involves a dissociative type of change experienced by the subject in his or her perception of things or himself. Reality appears distant, like a dream or a shadow, and it is at this point that false recognition occurs. Along with this displacement of the perceived object from the present into the past, there is a confused feeling of expectation



or foreknowledge, whereby the subject is simultaneously projected into the future. For Freud this involves the replacement of some part of reality by a repressed desire (1901b). In the example cited here, a young girl replaces the perception of her wish to have seen her brother die with the sensation of having already experienced the situation (a trip to the countryside to visit some young girls whose brother is seriously ill). The topographic displacement (unconscious/conscious) is also spatio-temporal, for the memory involves the house and the girls' dresses but not the brother's illness. In "A Disturbance of Memory on the Acropolis," the same phenomenon is reversed since the reality of the Acropolis dissolves within the feeling of disbelief Freud experiences. Here, doubt replaces certainty; doubt is awakened by the reality of the perception but contaminates perception at the same time.

The concept of *déjà vu* must be compared with other analogous terms in analysis, such as *déjà vécu* (already experienced) and *déjà raconté* (already communicated). According to Freud, this paramnesia can be explained as a confusion between the intention to communicate and its realization. As with the doubt in his dream, these forms of paramnesia refer to specifically significant facts, such as the hallucination of the severed finger that the Wolf Man is convinced he has already told Freud about, when, in fact, he had only mentioned the existence of the small knife carried by his uncle. Generally speaking, paramnesia leads to a reflection on the process of remembering during therapy and on the patient's illusion of having "always known" the repressed content revealed by interpretation ("Remembering, Repeating, Working-through"). "It is by this means," Freud writes, "that the problem of analysis is resolved" (1914g).

*Déjà vu* touches on the whole question of forgetting as a dissociation of memory, as well as on the question of true and false from the psychoanalytic point of view. The false recognition of Norbert Harnold ("Is it a 'real' ghost?") is the true recognition of the originally invested object displaced within the context of archeology in *Delusions and Dreams in Jensen's "Gradiva"* (1907a [1906j]).

SOPHIE DE MIJOLLA-MELLOR

See also: Certainty; Estrangement; Illusion.

### **Bibliography**

- Freud, Sigmund. (1901b). The psychopathology of everyday life. *SE*, 6.
- . (1907a [1906j]). Delusions and dreams in Jensen's "Gradiva." *SE*, 9: 1–95.
- . (1914a). Fausse reconnaissance ("déjà raconté") in psycho-analytic treatment. *SE*, 13: 199–207.
- . (1914g). Remembering, repeating, working-through (Further recommendations on the technique of psycho-analysis II). *SE*, 12: 147–156.
- . (1936a). A disturbance of memory on the Acropolis (an open letter to Romain Rolland on the occasion of his seventieth birthday). *SE*, 22, 239–248.

---

### **DELAY, JEAN (1907–1987)**

Jean Delay was a psychiatrist and writer, a professor of medicine in Paris, and a member of the Académie française and the Académie de médecine. He was born on November 14, 1907, in Bayonne and died on May 29, 1987, in Paris. He was the only son of Maurice Delay, a surgeon who went to Bayonne to practice and ultimately became mayor, and Berthe Mihura, a musician, mystic, and cultured woman from an old Basque family. Delay obtained his baccalaureate degree when he was only fourteen and a half, and had to obtain permission from Léon Bérard, minister of education, to attend medical school. He was less than sixteen when he left for Paris to study medicine, and he remained a precocious student throughout his life. He excelled as an extern at the hospital but soon discovered that he had little interest in surgery and enrolled in the university's literature department. Georges Dumas, who held the chair of psychopathology at the Sorbonne, introduced Delay to psychiatry.

In 1928 Delay was an intern, the youngest doctor in the Paris hospital system, and in 1939 he joined the staff of the Sainte-Anne Hospital, where he worked with Henri Claude and Maxime Laignel-Lavastine. After the Germans deported Joseph Lévy-Valensi, Delay became head of the psychiatry department. He served as an expert adviser at the Nuremberg trials, where he examined Rudolf Hess and Julius Streicher. In 1946, when he was only 38 years old, Delay was appointed to the chair of mental illness and brain diseases and later held the Charcot chair until 1970, when he retired.

After defending his doctoral dissertation in literature, entitled “Dissolutions de la mémoire” (1942), which was influenced by the work of Pierre Janet, he became part of the great tradition of French psychopathology through such publications as *Les dérèglements de l’humeur* (1946) and *Études de psychologie médicale* (1953). Upon the departure of Henri Piéron, he became director of the Institut de Psychologie at the University of Paris.

Delay was chair of the first International Congress in Psychiatry held in Paris in 1950 and was elected member of the Académie de médecine in 1955. His neurological training is reflected in his dissertation on tactile agnosia and other work published in this area. He coined the term “neuroleptic” and introduced the use of reserpine into psychiatry. His interests extended to the use of antidepressants, and he completed his research on mescaline by studying LSD and psilocybin, which he referred to as “oneirogenics.” He was also involved in the discovery of Lergactil, used in psychopharmacology. In 1960 he chaired the first Congrès de médecine psychosomatique (Congress of Psychosomatic Medicine).

Édouard Pichon introduced him to psychoanalysis before the Second World War during a brief training analysis. Delay retained a nuanced, non-doctrinaire attitude toward Sigmund Freud’s work. During the Occupation, the psychoanalysts John Leuba, Georges Parcheminey, Jacques Lacan, and Marc Schlumberger worked in his department; after the war Jacques Lacan and André Green had a psychoanalytic practice there. His department also hosted Jacques Lacan’s Wednesday seminars (from November 18, 1953, to November 20, 1963) and Friday seminars, until it was decided that they were no longer appropriate. He remained suspicious of the “quacks of the unconscious” and what he considered poorly managed psychoanalysis. Delay was elected to the Académie française in 1959.

Throughout his life Delay maintained a literary career, his work initially being published under the pseudonym Jean Faurel (*La cité grise* [1946], *Les reposantes* [1947], *Les Hommes sans nom* [1948]). His two-volume work on André Gide, *The Youth of André Gide* (originally published in 1956–1957), soon became famous. Jacques Lacan, in “Jeunesse de Gide, ou la lettre et le désir” (1966), wrote, “Jean Delay extends this ambiguity by locating the effect within the soul, at the very place where the message is formed.” He also worked on a historical reconstruction of his mother’s

family in the four volumes of *Avant-mémoire* (1979–1986).

In a final homage to Delay at the Académie française, Jean Dutourd wrote, “In the case of Jean Delay, who knew everything, who had explored medicine’s most hidden pathways, the philosophy of the past, and even madness, we do not have the feeling we are talking with a contemporary but with one of those immense gluttons for knowledge who made the Quattrocento and the sixteenth century so amazing. Nor was he contemporary in his behavior. In his courtesy, his refinement, and his kindness, he was the kind of gentleman one might have found in Balthazar Castiglione, and an ‘honest man’ as well.”

CLAUDE DELAY

See also: France; Narco-analysis; Sainte-Anne Hospital.

### Bibliography

Delay, Jean. (1946). *Les dérèglements de l’humeur*. Paris: Presses universitaires de France.

Delay, Jean. (1947). *Les reposantes*. Paris: Gallimard.

Delay, Jean. (1953). *Études de psychologie médicale*. Paris: Presses universitaires de France.

Delay, Jean. (1956). *Aspects de la psychiatrie moderne*. Paris: Presses universitaires de France.

Delay, Jean. (1960). *Discours de réception à l’Académie française*. Paris: Gallimard.

Delay, Jean. (1963). *The youth of André Gide* (June Guichard, Trans.). Chicago: University of Chicago Press. (Abridged.)

Delay, Jean. (1971–1986). *Avant-mémoire*. Paris: Gallimard.

Lacan, Jacques. (1966). Jeunesse de Gide, ou la lettre et le désir. In his *Écrits*. Paris: Seuil.

---

## DELBOEUF, JOSEPH RÉMI LÉOPOLD (1831–1896)

Joseph Delboeuf was a Belgian psychologist and hypnotherapist. He was born in Liège on September 30, 1831, and died in Bonn on August 13, 1896. He was a professor at the University of Ghent from 1863 to 1866 (philosophy), and after 1866 taught at the University of Liège (Latin, Greek, and psychology). Signs of Delboeuf’s influence can be found in many places in Sigmund Freud’s work, at least until 1900. The most significant include:

1. Delboeuf treated a woman traumatized by the death of her son. He eliminated her symptoms, which resembled the terrible conditions of his death, by having her relive those experiences several times. Delboeuf explained “how the magnetizer assists in the healing process. He places the subject in a state where the evil has manifested itself and through speech combats that same, recurring evil.” Freud discussed this hypothesis extensively in “On the Psychological Mechanism of Hysterical Phenomena” (1893a) and in the *Studies on Hysteria* (1895d).
2. Looking back on his therapy with Emmy von N., Freud doubted for the first time the value of claims by Bernheim and the “perspicacious” Delboeuf. He questioned whether Bernheim was correct in continuing to claim that “suggestion is everything,” and Delboeuf for having claimed that “that being so, there is no such thing as hypnotism.” Unable to resolve these issues, he abandoned theory and turned to practice, finally showing preference for the analytic and genetic method, which was in fact that of Delboeuf.
3. Delboeuf’s *Le Sommeil et les Rêves* [Sleep and Dreams] (1885) and Freud’s *Interpretation of Dreams* (1900a) have several traits in common. Delboeuf’s work opens with the famous dream of the lizards and the *Asplenium*, an intriguing dream from several points of view and one that led the psychologist to articulate his conception of memory and remembrance, whose meaning he attempted to grasp through the randomness of free association. In the *Interpretation of Dreams* two of Delboeuf’s concepts are treated favorably: “forced rapprochement” (to account for the tendency of dreams to merge) and “cliché” to explain the presence of verbal expressions in certain dreams. Having decided to use his own dreams for hermeneutic purposes, Freud acknowledges that he had to overcome [conquer] his initial reticence. He remarks that he overcame his resistance by subjecting it to a process expressed by Delboeuf, whom he quotes: “every psychologist must acknowledge even his weaknesses if he feels he can shed light on a problem by doing so” (Freud, 1900a; Delboeuf, 1885, p. 30).

FRANÇOIS DUYSKAERTS

See also: Congrès international de l’hypnotisme expérimental et scientifique, First; *Disque vert*, *Le*; Hypnosis; Suggestion.

### Bibliography

- Delboeuf, Joseph. (1885). *Le Sommeil et les rêves*. Paris: Félix Alcan; *Le Sommeil et les rêves et autres textes*. Paris: Fayard, 1993.
- . (1889). *Le Magnétisme animal. À propos d’une visite à l’École de Nancy*. Paris: Félix Alcan.
- Duyckaerts, François. (1993). “Les références de Freud à Delboeuf.” *Revue Internationale de Psychanalyse*, 6, 231–250.
- Freud, Sigmund. (1895d). *Studies on hysteria*. SE, 2.
- . (1900a). *The interpretation of dreams*. SE, 4–5.

---

## DELGADO, HONORIO (1892–1969)

A Peruvian psychiatrist and philosopher, Honorio Delgado was born in Arequipa on September 26, 1892, and died in Lima on November 20, 1969. Delgado studied natural science at the University of San Agustín in Arequipa before becoming a surgeon (1918) and a doctor of medicine (1920) at the University of San Marcos in Lima. A self-taught psychiatrist (formal training then being unavailable), Delgado was a precocious and enthusiastic proselytizer for psychoanalysis in Peru and Latin America between 1915 and 1927. His first publication on psychoanalysis appeared in 1915 when he was only twenty-three years old. Published in *El Comercio*, it was a commentary on Sigmund Freud’s “The Claims of Psycho-analysis to Scientific Interest,” which appeared in 1913 in *Scientia*, which Delgado read on a regular basis.

In 1922 he traveled to Europe to attend the Berlin congress but his ship was delayed and he missed the presentations. In 1927 he traveled to Innsbruck for the annual congress. He published the first work in Spanish on psychoanalysis, entitled *La Psychanalyse* (1919). Between 1919 and 1934 he corresponded with Freud, whom he met in Weimar in 1922 and visited in Semmering in 1927. In 1918, together with Hermilio Valdizán, he founded *Revista de psiquiatría y disciplinas conexas* (Review of Psychiatry and Related Disciplines), which adopted a favorable position regarding psychoanalysis. In 1921 he

published “Der Liebesreiz der Augen” (The Amorous Attraction of the Eyes) in *Imago*. In 1926, with the collaboration of several eminent Peruvian intellectuals, he edited a special issue of *Mercurio Peruano* devoted to Freud. That same year he also published a biography of Freud, which Freud annotated extensively throughout their correspondence. Freud took an active interest in Delgado’s publications, and the way he responded to his eclectic approach to psychoanalysis, which was in several respects related to the ideas of Alfred Adler and Carl Gustav Jung, should not come as a surprise.

After 1930 Delgado held the country’s only chair in psychiatry and became a fierce adversary of psychoanalysis, paradoxically citing in his support the references to him made by Freud in a 1923 note added to “On the History of the Psychoanalytic Movement” (1914d) and in an article written in English in 1924, “A Short Account of Psycho-analysis” (1924f [1923]).

While still a young man Delgado had identified with Freud’s initial period of isolation. There exists a letter, collectively written by Ernest Jones, Hanns Sachs, and Oskar Pfister, congratulating Delgado for his *Pionierarbeit*. His later rejection of psychoanalysis appears to have arisen from his growing popularity and a refusal—which he never concealed—to accept some of the fundamental premises of psychoanalysis, coupled with his increasingly strong attachment to Catholicism. In spite of his productivity as a writer, his lack of clinical experience is obvious (he had no personal experience of psychoanalysis aside from his own self-analysis). His early work contains little of lasting value and there is an obvious difference in quality with his later work in psychiatry, influenced by the phenomenology of Karl Jaspers.

His correspondence, however, contains numerous insights into Freud’s ideas about creating an institutional structure as well as Freud’s tendency to pardon some of Delgado’s theoretical errors, for which he would certainly have been less indulgent in other circumstances. His letters contain no more than mild rebukes to Delgado for his sympathy toward Adler (with whom he corresponded) and Jung.

ÁLVARO REY DE CASTRO

See also: *Revista de psiquiatría y disciplinas conexas*; Peru.

### Bibliography

- Ellenberger, H. (1970). *The discovery of the unconscious: The history and evolution of dynamic psychiatry*. New York: Basic Books.
- Mariátegui, Javier. (1989). *Freud y el psicoanálisis*. Lima: University Cayetano Heredia.
- Rey de Castro, Álvaro. (1983). Correspondance Sigmund Freud–Honorio Delgado. *Revue Internationale d’Histoire de la Psychanalyse*, 6, 1993.
- . (1991). Freud y Honorio Delgado: una aproximación psicoanalítica a la prehistoria del psicoanálisis peruano y sus escuelas. El múltiple interés del psicoanálisis—77 años después, *Talleres de artes gráficas espino*, 203–237.
- . (1993). Lettres de Sigmund Freud à Honorio Delgado, 1919–1934. *Revue Internationale d’Histoire de la Psychanalyse*, 6, 401–428.

---

## DELUSION

The first essential feature that defines a delusion is that it concerns something that appears to be external to the subject. It is thereby distinguished from obsessive ideas and *idéés fixes*. More precisely, we can say that in a delusion, an internal experience appears in the perceptual field. Delusion therefore concerns reality as a whole, which distinguishes it from phobia, where the distortion of reality is more circumscribed, because projection manages to localize conflict, and keep the rest of the subject’s mental life intact. In delusion, conversely, the whole of reality is affected, and indeed the delusion, for the subject, is the whole of reality.

In this sense, delusion represents a critical risk. Sigmund Freud speaks accordingly of a necessary restoration of the object (1924e), whether it is a matter of the high level of libidinal or narcissistic tension evident in extreme cases, or a fundamental questioning of identity and relations with others that is at stake.

Delusion is therefore something other than error. Being delusional remains compatible with an accurate apprehension of reality. We can even consider the delusional individual as deprived of the freedom to establish a flexible relationship between reality and truth, as Paul-Claude Racamier has said.

From this general perspective, we can differentiate the two main modalities for the expression of delusions. In one, this involves a disturbance of consciousness, whose heightened character can have different

causes: a consciousness that is captive and agonized; or a *delirium tremens*, which externalizes metabolic disturbances in the form of images; or the dream-like upheaval of acute psychotic delusions; or the psychedelic intoxication of hallucinogens. In the other mode, the same reversal of reality can express the refusal that occurs during hallucinatory confusions that seek to isolate a repressed complex, and keep it in a shadowy, hysterical state.

There are occasions, however, when acute delirious moments are experienced in isolation, as in the "primordial delusional fact" described by Jacques Moreau de Tours, or the "primary delusional experience" described by Karl Jaspers, where the strange and uncanny appears, sometimes in the form of illuminating moments in which a perception takes on a revelatory quality, or a moment of questioning emerges without yielding any sense. These seem to be direct confrontations between unconscious fantasy and reality, like a topographical short-circuit that requires a return of the preconscious from the exterior world, within the delusion of interpretation.

In yet another dynamic of delusion, less sharp in its temporal unfolding, the dominant issue concerns the limit between inside and outside. During moments of mental automatism, thought grows heavy with the weight of words that have lost their meaning. The schizophrenic seeks in hallucination to exteriorize an internal life that is invasive and does not seem to belong to him. Chronic delusions, in the French systems of classification, or in Kraepelin's paraphrenias, are more likely to create delusions that are simultaneously persecutory and protective, sometimes to the point of allowing a reconstruction of the entire world (Schreber, 1903).

Passion also, with its affective power to dominate, can provide material for delusions, along other lines. The paranoiac projection of homosexual impulses can turn into delusions of persecution, jealousy, or erotomania, depending on whether it is the subject or the object of the fantasized investment that is affected by the delusional force. However, emphasis should be placed on the narcissistic demand, the lack of an object, and the shortcoming, within the primary homosexual relation, that eroticization compromises and which the delusion of persecution maintains as both present and distant (Jenneau, 1990). In other cases it is the superego that returns in the "delusion of reference," where the shame and guilt of voyeurism blend together in projection (Kretschmer, 1927).

One sees in this brief description that delusion cannot be explained simply in terms of a certain way of treating instinctual life at the expense of reality. One also has to take into account the patient's need to express conflict, in a single-minded way, within this reality. It is the causality of delusion that remains the foremost question, even within radically different accounts.

*See also:* Aimée, case of; Amentia; Certainty; "Claims of Psychoanalysis to Scientific Interest"; Construction-reconstruction; "Constructions in Analysis"; Erotomania; Hypochondria; Illusion; Infantile omnipotence; "Metapsychological Supplement to the Theory of Dreams"; Need for causality; Negative hallucination; "Notes upon a Case of Obsessional Neurosis (Dementia paranoides)"; "On Narcissism: An Introduction"; Paranoia; Paranoid psychosis; Persecution; Projection; Psychoanalytical nosography; Psychoses, chronic and delusional; Psychotic defenses; Psychotic potential; Superego.

### **Bibliography**

- Freud, Sigmund. (1924e). The loss of reality in neurosis and psychosis. *SE*, 19, 180–187.
- Jaspers, Karl. (1913). *Allgemeine psychopathologie*. Berlin: Springer.
- Jenneau, Augustin. (1990). *Les délires non psychotiques*. Paris: Presses Universitaires de France.
- Kretschmer, Ernst. (1963). *Paranoïa et sensibilité*. Paris: Presses Universitaires de France. (Original work published 1927)
- Schreber, Daniel Paul. (1988). *Memoirs of my nervous illness*. (I. Macalpine, R. Hunter, Trans.) Cambridge: Harvard University Press. (Original work published 1903)

### **Further Reading**

- Robbins, Michael. (2002). The language of schizophrenia and the world of delusion. *International Journal of Psychoanalysis*, 83, 383–406.
- Shengold, Leonard. (1995). *Delusions of everyday life*. New Haven: Yale University Press.

---

## **DELUSIONS AND DREAMS IN JENSEN'S "GRADIVA"**

Freud wrote this essay in the summer of 1906, seemingly to please Carl Gustav Jung, who had called to his attention a short story by the German writer

Wilhelm Jensen that was of interest because a dream served as its point of departure.

In his essay Freud first minimally summarized and commented on the story. It is the story of Norbert Hanold, a young archeologist obsessed with his work for whom women do not exist. Visiting a museum, he is struck by the beauty of a bas-relief of young Roman woman, very light on her feet, whom he baptized “Gradiva” (she who walks). He purchases a reproduction, which he hangs on the wall of his workroom. Gradually his mind is invaded by the enigma of this young woman. One night he dreams that he is in Pompeii in August 79 c.e., just before the eruption of Mt. Vesuvius. There he meets Gradiva and wants to warn her of the terrible danger that is about to occur, but he is powerless to rescue her. After waking, he is overcome by the desire to meet Gradiva. He leaves for Pompeii, where he meets a young woman, very much alive, whom he takes for Gradiva. In the course of the meetings that follow, he organizes his mania, stalking and interpreting signs (Gradiva appears at noon, the ghost hour, and the like). “Gradiva” seeks to cure him by gradually revealing her identity to him. Through this adventure, Norbert finally sees “Gradiva” for who she really is: his neighbor and childhood friend Zoe Bertgang (“Bertgang” is the German equivalent of “Gradiva”), who also traveled to Pompeii. For years he had not seen her and had no desire to see her, but, in love without knowing it, he had displaced his love on the young woman of the bas-relief, Gradiva. Happily, the mania yields to reality, and Norbert is cured.

Frequently citing his *Interpretation of Dreams* (1900), Freud suggested in his comments that dreams “invented” by a writer can be analyzed by the same method as real ones. He meticulously analyzed the two dreams figuring in Jensen’s story, linking them to residues of daytime occurrences. He thus demonstrated that dreams were substitute wish fulfillments and established that they constitute a return of the repressed. The source of Norbert Hanold’s mania is his repression of his sexuality, which caused him to forget Zoe Bertgang, so as to keep him from recognizing her (anticipating his later views, Freud called such phenomena “negative hallucinations”).

The dream and the mania that makes the dream real function by condensation and displacement, by way of images. The correct proposition—I, Norbert, am living in the same time and place as Zoe—is removed to Pompeii in the year 79. Zoe treats Norbert in the manner of a

good psychoanalyst, cautiously bringing to consciousness what Norbert forgot through repression.

Freud’s essay was published in May 1907. Four months later, in September, in the course of a trip to Rome, he went to see the bas-relief representing “Gradiva” at the museum of the Vatican, the same bas-relief that had inspired Jensen’s tale. Just like Norbert, Freud bought a copy of it and hung it in his office, at the foot of the divan. He left it there until he left Vienna, and took it with him to London in 1938.

ROGER PERRON

*See also:* Anxiety dream; Applied psychoanalysis and the interaction of psychoanalysis; Archeology, the metaphor of; Fantasy; Literary and artistic creation; Negative hallucination; Passion.

### Source Citation

Freud, Sigmund. (1907a [1906]). *Der Wahn und die Träume in W. Jensens Gradiva*, Leipzig-Wien, Hugo Heller; *G.W.*, 7, 29–122; *Le Délire et les Rêves dans la “Gradiva” de W. Jensen*, trad. J. Bellemin-Noël, Paris, Gallimard, coll. “Connaissance de l’inconscient,” dir. J.-B. Pontalis, 1986; Delusions and dreams in Jensen’s “Gradiva.” *SE*, 9, 1–95.

### Bibliography

Engelman, Edmund. (1976), *Bergasse 19, Sigmund Freud’s home and offices, Vienna, 1938: The photographs of Edmund Engelman*. New York: Basic Books.

Freud, Sigmund. (1900). The interpretation of dreams. *SE*, 4, 1–338; 5, 339–625.

---

## DEMAND

The concept of demand is not Freudian. It was developed by Jacques Lacan, who linked it with need and desire (Lacan, 1966, 1991). Demand is identifiable by the five clinical traits that constitute it, by the status that it gives the object, by its function in relation to the Other, and finally by its topological register.

Regarding demand, we can say that 1) it arises only from speech; 2) it is addressed to someone; 3) it is nevertheless only implicit; 4) it is related to a need for love, but also to desire; 5) it does not need to be sustained by any real object.

The object of demand is what is lacking in the unconscious Other, and thus it is only a fantasmic object. Its function is to satisfy the drive and to make the demand of the subject and the demand of the Other coincide. Although it is tied to both the symbolic and the real, the register of demand is primarily imaginary, and thus most closely related to the body.

Before outlining more recent perspectives on demand, we must return to what Lacan said about it in relation to oral, anal, and genital regions of the body that serve as the sources of demand.

The oral demand calls for an inverse response, such that the other's answer to the imperative "feed me" is "let yourself be fed." This inversion becomes a source of discord or even of destructive urges. To whom is the demand addressed? To the Other, and not the mother. It is addressed to the Other that separates the demand from a desire. And that desire, in turn, deprives the demand of its satisfaction. Thus the demand becomes a non-demand. The dream of the "beautiful butcher's wife," as reported by Freud, is a perfect example of this. What is the object of her desire to define? It is a cannibalistic object. This desire is directed towards the nourishing body, an organic unconscious object through which the demand's relation to the Other can be sexualized. This libidization, "which is nothing but surplus," deprives the need of its gratification. The function of desire, which sustains all demand, is in turn maintained in it and thus preserved. Desire can be recognized in the field of speech by the negation with which it originates: this, and not that!

The original oral relation between the mother and her child is constantly fed by a kind of hostility in which each one is convinced, at the imaginary level, of being "bawled out" by the other. Donald Winnicott (1974) emphasizes moreover that the object is so good, so exciting—that it bites. Consultations with mothers and children always show this.

At the anal stage, need reigns supreme; but while demand sets out to restrain need, desire wants to expel it. The one is entrusted with satisfying it, while the other is determined to control it. In the end, this control is legitimated only by turning need into a gift expected by an other, who is always primordially the mother. The oblation of this exonerating gift is metonymic. In order to evacuate the gift of symbolic desire, the one who gives it (child, student, or citizen, for example) could well adopt the slogan "everything for

the other" in reference to the one who expects it (the mother, the teacher, or an authority figure)—this is true enough in the voting booth, at any rate. Such a gift is not produced by the one who gives it: someone else is the producer, someone who is able to wait for it only as long as the giver is suffering. It is not that the gift is necessarily painful in itself; the reaction of the one who receives it is the determining factor in that respect. So that her expectations will not be in vain, the mother eroticizes her relation with the child. She makes the child a sexual partner, involved in a fantasy in which he becomes the imaginary phallic object. In the end, the child will have been forced to do the only thing it was able to do. This was how the sadomasochistic economy was described by Freud, who took the symbolic equivalence of penis, feces, and child as his starting point.

How do we recognize an obsessional neurosis? By a declared conflict between demand and desire, satisfaction and discipline, need and legitimacy, gift and exoneration. The outcome of this conflict can only be a resignation to suffering. The characteristic "it could have been worse" attitude alludes to the masochistic *jouissance* that the obsessional derives from it, while "You had that coming" sums up the sadistic expectation of the other, who is without doubt the father—when it comes to need, he's always too much.

At the genital stage, demand seeks out a real partner. A repressed demand returns in the field of sexuality, and it will be satisfied only by a real engagement—one the subject wants to wait for, since he or she intends to bring it about. Thus the demand is based on the primacy of a sexual desire that is certainly sustained by a need, but that emphasizes a real lack in the other. Far from realizing desire, this lack constantly renews it. "The subject does not know what he desires most," either from the other or in terms of his own lack. From then on, the "something else" that originates from this lack of knowledge is related to a desire that is deceived. It is deceived if it believes itself to be lacking only the other, the missing half that is but a shadow from the past.

Taking the concept of transitivity as their point of departure, Gabriel Balbo and Jean Bergès (1996) have reconceptualized the analysis of demand. For them, demand cannot be conceived independently of the infant's identification with the discourse that the mother expresses in response to the baby's cries, smiles, gurgling, and gestures. There is a double division at work here. The mother's own discourse, which she puts in the mouth of her child, divides the mother into

a bodily, experienced real demand in contrast to what she expresses. The child is also divided from its own real demand by identifying with whatever part of that demand the mother expresses. This double division, with its consequent double repression, has an organizing influence on the ego, the status of the object, body image, the infant's jubilation at its own specular image, and the I. All processes of identification must be rethought in these terms, while at the same time demand and identification are also the origin of no less a dualism than that of life and death.

Such an analysis allows one to rethink the demand for an analysis, the preliminary interviews, the analytic contract, the direction and conduct of the treatment, and ultimately the transference. This reconceptualization reaches the very core of the discursive framework, and the analysis of dreams as well as the patient's speech is determined by it.

GABRIEL BALBO

*See also:* Graph of Desire; Metonymy; Neurosis; Object *a*; Other, the; Subject of the unconscious; Symbolic, the (Lacan); Topology; Unary trait; Wish/yearning.

### Bibliography

- Balbo, Gabriel and Bergès, Jean. (1996). *L'Enfant et la psychanalyse*. Paris: Masson.
- Lacan, Jacques. (1966 [2002]). *Écrits*. Paris: Seuil. *Écrits: A selection*. (Bruce Fink, Trans.). New York: W. W. Norton.
- . (1991). *Le Séminaire-livre VIII, le transfert* (1960–61). Paris: Seuil.
- Winnicott, Donald W. (1974). The fear of breakdown. *International Review of Psychoanalysis*, 1. Reprinted in *Psychoanalytic explorations*. (1989). Cambridge, MA: Harvard University Press.

## DEMENTIA

Dementia has been defined in two very different ways. The first definition, which came into use in the nineteenth century with the establishment of a nosographic framework for the psychoses, culminated in the concept of dementia praecox in the work of Emil Kraepelin. The second definition concerns altered states in memory and ideation following injury to the brain.

The word *dementia*, which first appeared in a psychiatric sense in Philippe Pinel's work contrasting

mania and dementia, underwent changes in meaning during the nineteenth century. In 1911 Eugen Bleuler, in his discussion of the concept of schizophrenia, centered around dissociation or splitting (*Spaltung*), proposed bringing together the old notion of "vesanic dementia" (the culmination of psychotic development) and Kraepelin's three forms of dementia praecox: hebephrenic, catatonic, and paranoid.

Sigmund Freud approved of Kraepelin's approach but he criticized the term *dementia praecox*, as well as the term *schizophrenia*. This despite the fact that he felt it important to distinguish between the two, writing, in "Psycho-Analytical Notes on an Autobiographical Account of a Case of Paranoia (Dementia Paranoides)" (1911 c[1910]): "... we shall hope later on to find clues which will enable us to trace back the differences between the two disorders (as regards both the form they take and the course they run) to corresponding differences in the patients' dispositional fixations" (p. 62). In reality, he continued to use both terms indiscriminately. He focused his study of the psychoses on paranoia in the essay cited above. After "On Narcissism: An Introduction," (1914) he proposed to distinguish among the neuroses, the psychoses, and the perversions. In Freudian theory, dementia praecox consists of a withdrawal of object libido onto the ego through regression and fixation. Freud later went on to specify its linguistic characteristics (words are subjected to the primary process) and its functioning (reality testing is no longer operant; verbal delusions are an attempt at healing), but essentially it was Freud's successors who developed a psychoanalytic theory of the psychoses.

In current usage, the term *dementia* refers to erosion of the intelligence caused by many different kinds of damage to the brain: degenerative dementias (dominated by Alzheimer's disease), vascular diseases, infectious diseases, toxic conditions, or metabolic disorders. Clinical treatment of dementia from a psychoanalytic perspective runs up against problems of theoretical elaboration. Psychoanalysis has limited applications for these conditions and is used mainly in the early stages of illness. The goal is to limit the breakdown of identity for a certain time. The gradual erosion of the capacity for symbolization and the work of representation owing to memory loss, the weakening of repression and the breaking through of the protective shield, and the instinctual flooding that ensues, has led to reliance on a therapeutic approach focusing



on the reconstitutive function of the affects as the basis for mental activity, since, as Michèle Grosclaude suggested in *Le Statut de l'affect dans la psychothérapie des démences* (The status of the affects in the psychotherapy of dementia; 1997), verbal therapies are among the first to be affected by the degenerative process. Denial, projective delusions, and heightened anxiety are all typical of these conditions.

RICHARD UHL

*See also:* Ego; Infantile psychosis; Infantile schizophrenia; Narcissism, secondary; Organic psychoses; Paranoid psychosis; Paraphrenia; "Psycho-Analytic Notes on Autobiographical Account of a Case of Paranoia (Dementia Paranoides)"; Schizophrenia; "Unconscious, The"

### **Bibliography**

Freud, Sigmund. (1911c [1910]). Psycho-analytical notes on autobiographical account of a case of paranoia (dementia paranoides). *SE*, 12, 9–82.

———. (1914). On narcissism: an introduction. *SE*, 14, 73–102.

———. (1915). The unconscious. *SE*, 14, 166–204.

Grosclaude, Michèle. (1997). *Le Statut de l'affect dans la psychothérapie des démences*. *Psychothérapie des démences*. Montrouge, France: John Libbey Eurotext.

---

**DENIAL.** *See* Disavowal

---

## **DENMARK**

After World War I, psychoanalysis was diffused among artists and pedagogues, but the discipline was condescendingly dismissed by the leading university professors in philosophy, psychology, and psychiatry.

After hearing a speech by Ernest Jones in 1926, though, the psychologist Sigurd Næsgaard became the first Dane to undertake a serious study of Freud. In February 1933, Wilhelm Reich gave a speech in Copenhagen and the IPA was requested to allow him to come to Denmark as a training analyst; the answer, however, was negative. Instead the Danes were offered Jenö Hárnik from the Institute of Psychoanalysis in

Berlin. Unfortunately he turned out to be psychically ill, and all that survives of his brief stay in Denmark are the reports of the scandal caused by his behavior. Reich was to come to Denmark anyway in May 1933, but as a political refugee. He was only granted six months' asylum, which was not extended, as he was suspected of practicing psychoanalysis without the requisite work permit.

Reich nonetheless remained in touch with a circle of disciples in Denmark during his ensuing stays in Sweden and Norway. Another influence came from Oskar Pfister, who enjoyed a certain popularity among prominent theologians and teachers. He gave a series of much-attended talks in Copenhagen in 1936.

From 1930 on, a series of more or less short-lived psychoanalytic societies were founded in Denmark, all marked by their respective founders and leaders. The most important was the group that surrounded Sigurd Næsgaard, who in the public eye was largely identified with Danish psychoanalysis. Another group was led by P. C. Petersen, who had a background in dairy production, and it represented especially the inspiration of Pfister. A third group arose around Reich's Danish pupils, led by the physicians J. H. Leunbach and T. Philipson; these were known in particular for their work in the movement for sexual reform.

The person with the greatest influence on the establishment of psychoanalysis in Denmark was Sigurd Næsgaard (1883–1956). He started as a teacher and then completed a university degree in philosophy and psychology. He had strong roots in the Danish high school movement, and considered general education, education reform, and sexual freedom his most important goals. As a psychoanalyst he was self-taught. His large authorship is characterized by a popularizing tendency and a predilection for pat and quick-witted interpretations. He is known for his analyses of a number of the important cultural figures of his time, among others the painter Asger Jorn. Some of the leading Danish IPA analysts after World War II also started their analytic careers on his couch.

The Danish-Norwegian Psychoanalytic Society that was founded at the IPA congress in 1934 had only one member with a Danish address, the Hungarian Georg Gerö, a pupil of Reich who had been educated at the Institute of Psychoanalysis in Berlin. Under pressure

from the IPA, Gerö broke with Reich around 1937. The only known work of his in Denmark today is his training analysis of the psychiatrist Poul Færgeman. Gerö emigrated to the United States at the beginning of World War II.

Færgeman (1912–67) left for the United States in 1946 to terminate the training analysis he had started with Gerö in Denmark. He later became a member of the New York Psychoanalytic Society, but returned to Denmark in 1960 and joined the Danish society. He is best known for his work with psychogenic psychoses (Færgeman, 1963). Because of his premature death he was not to have the influence on Danish psychoanalysis to which he seemed entitled.

After the war, Næsgaard and Petersen each established new societies. Both sought admission to the IPA, but since neither had had IPA-accredited training, they were unsuccessful. Instead, the initiative slid to another group. The Swedish analyst Nils Nielsen, member of the IPA, came to Denmark in 1949 with a view towards starting a number of training analyses and founding a psychoanalytic society. The Danish psychiatrists Thorkil Vanggaard and Erik Bjerg Hansen, who had received accredited psychoanalytic training in New York and Vienna, respectively, later joined Nielsen. Their Danish Psychoanalytic Society attained status as a study group under the IPA in 1953 and obtained full IPA membership in 1957. The society hosted the international IPA congresses in 1959 and 1967. The accession of members was low, as was the level of activity throughout the 1960s and 1970s.

Thorkil Vanggaard (1910–1998) was the strong leader of the Danish Psychoanalytic Society in the years following World War II. He received his psychoanalytic training in New York with Robert Bak as his training analyst. His psychoanalytic authorship is not prolific, but a fairly original theory of the phallus as a meditating symbol in connection with the transfer of authority from master to pupil merits mention (Vanggaard, 1972). He was vice president of the IPA from 1967 to 1969, but then began to move away from psychoanalysis and left the psychoanalytic society in 1984. He is known to the Danish public rather for his highly controversial position on gender roles and incest than as a psychoanalyst.

Not till 1980 was the increasing general interest in psychoanalysis reflected in the number of members. Among the Danish public, psychoanalysis has mainly

been represented by psychologists, researchers and writers with no analytical training (e.g., Andkjær Olsen and Køppe, 1988).

In the 1990s the Danish Psychoanalytic Society had around 30 full members, of whom more than one third are from the southern part of Sweden, having chosen to belong to the Danish society due to the fact that Copenhagen is closer than Stockholm. There is no institute, and the society depends greatly on its collaboration with the other Scandinavian societies, who among other things have cooperated since 1978 on the publication of the *Scandinavian Psychoanalytic Review* (in English).

Among the societies that do not belong to the IPA are the Group Analytic Institute (established with the support of the British group analysts Colin James and Malcolm Pines) and the Psychoanalytic Circle (Lacanian).

OLE ANDKJÆR OLSEN

### Bibliography

- Andkjær Olsen, Ole, and Køppe, Simo. (1988). *Freud's theory of psychoanalysis*. New York: New York University Press.
- Færgeman, Poul. (1963). *Psychogenic psychoses*. London: Butterworths.
- Reimer, Jensen, and Paikin, Henning. (1980). On psychoanalysis in Denmark. *Scandinavian Psychoanalytic Review*, 3, 103–16.
- Paikin, Henning. (1992). Denmark. In P. Kutter (Ed.), *Psychoanalysis international. A guide to psychoanalysis throughout the world* (Vol. 1, Europe). Cannstatt: Frommann-Holzboog.
- Vanggaard, Thorkil. (1972). *Phallos*. New York: International Universities Press.

## DEPENDENCE

The term “dependence” is part of contemporary language; it is frequently used in the field of psychopathology but more for descriptive convenience than to specify a precise relational modality concerning the subjection of a subject to an object. Sigmund Freud used the term infrequently but made reference to it in his discussion of the pleasure principle: “It will be rightly objected that an organization which was a slave

to the pleasure principle and neglected the reality of the external world could not maintain itself alive for the shortest time, so that it could not have come into existence at all. The employment of a fiction like this is, however, justified when one considers that the infant—provided one includes with it the care it receives from its mother—does almost realize a psychical system of this kind” (1911b). Serge Lebovici (1991) remarked that the human being’s original state of dependence is a fundamental postulate of Freudian theory; it is the baby’s *Hilflosigkeit*, or helplessness (*détresse* or *désaide* in French).

As Michael Balint (1968) remarked, the notion of “oral dependence” appeared in the work of Otto Fenichel in 1945. Fenichel describes oral character traits, especially a disguised dependent need, created by reaction-formation, manifest in attitudes and behaviors of independence and rebellion. Franz Alexander used this idea to describe ulcerous subjects who indicate their condition by the conflict between the desire to maintain a state of infantile dependence and the affirmation of independence of the adult ego.

Melanie Klein showed no interest in the concept, but her students Paula Heimann and Joan Riviere, in *Developments in Psychoanalysis*, refer to the infant’s total dependence on the mother at the beginning of life. The concept becomes central in the thought of Donald Winnicott (1963), who emphasizes that the baby, who is dependent on the care of those around him, is subject to a “dual dependency,” which will become simple dependency as soon as he or she becomes aware of it.

This is part of a normal process for every human being, so that not every state of dependence later found to exist can be reduced to it. Yet this inaugural kernel, which is characterized by a sense of powerlessness (as well as the narcissistic omnipotence associated with it), is the basis of subsequently-observed states of mental dependence and defects in the separation-individuation process. Adolescence especially is a period of reactualization and the heightened revival of feelings of dependence and infantile helplessness. Philippe Jeammet (1989), who considers dependence to be characteristic of this period, has developed the concept within a metapsychological perspective that cannot be easily summarized. According to this conception, the adolescent shows himself to be clinically dependent whenever he feels that his object needs threaten his autonomy and narcissistic equilibrium.

Some authors have examined dependence in the treatment of borderline states, following Winnicott, who emphasized the danger of underestimating the transference dependence in this type of case as part of the counter-transference risks of his interpretation. He, like Balint, cautions against an overly systematic interpretation of transference dependence, introducing the risk of reinforcing the dependence—especially oral dependence—of the patient on the analyst, and the latter’s omnipotence. Otto Kernberg, working with narcissistic patients, describes their inability to depend on the analyst from the beginning of therapy, which can be compared to the fear of “giving in to dependence” described by Masud Khan.

In contemporary psychiatric clinics there has been a recategorization and clinical reassessment of dependence. The term is no longer only applied to drug addiction, alcohol or tobacco dependence, and so on, but tends to define a biological-psychological-behavioral syndrome that is very broad and includes those states as well as pharmacodependence. The concept of “addiction,” which is very similar to that of dependence, is an indication of this broadening. Thus the pathological behaviors in which an act of incorporation (often but not exclusively through use of a toxic object) allows the subject to relieve the internal tension by short-circuiting a threatening mental condition are grouped under the term “addiction.” These include alcoholic and drug-related behavior, bulimia (and anorexia), as well as addictions that do not involve the ingestion of a product (games of chance, shopping sprees, sexual addiction), and even relational dependence.

BÉNÉDICTE BONNET-VIDON

*See also:* *Addiction; Helplessness.*

### **Bibliography**

- Balint, Michael. (1968). *The basic fault. Therapeutic aspects of regression*. London: Tavistock Publications.
- Freud, Sigmund. (1911b). Formulations on the two principles of mental functioning. *SE*, 12, 218–226.
- Jeammet, Phillippe. (1989). Psychopathologie des troubles des conduites alimentaires à l’adolescence. *Confrontations psychiatriques*, 31, 177–202.
- Lebovici, Serge. (1991). La dépendance du nouveau-né. (pp. 29–39). In C. Dechamp-Le Roux (Ed.), *Figures de la dépendance, autour d’Albert Memmi, colloque de Cerisy-la-Salle*. Paris, Presses Universitaires de France.

Winnicott, Donald W. (1965). *The maturational processes and the facilitating environment; studies in the theory of emotional development*. New York: International Universities Press.

### Further Reading

Coen, Stanley. (1992). *The misuse of persons: analyzing pathological dependency*. Hillsdale, NJ: The Analytic Press.

Searles, Harold. (1955). Dependency processes in the psychotherapy of schizophrenia. *Journal of the American Psychoanalytic Association*, 3, 19–66.

Winnicott, Donald W. (1963). Dependence in infant care, child care, and the psychoanalytic setting. *International Journal of Psychoanalysis*, 44, 339–344.

## DEPERSONALIZATION

The term “depersonalization” refers to the appearance of subjective impressions of change affecting the person or the surrounding world. Their intensity varies, ranging from a simple feeling of dizziness to painful feelings of physical transformation, from the fleeting feeling of estrangement to the impression that the world has become unrecognizable, dead, or uninhabited. Moments of depersonalization can occur during the customary development of any individual or within overtly pathological clinical settings.

The concept of depersonalization is not directly present in the work of Sigmund Freud. In “Psychoanalytic notes on an autobiographical account of a case of paranoia (dementia paranoides)” (1911c [1910]), the elements of depersonalization perceptible in the subject’s memory—themes of physical transformation, nerves of voluptuousness, the “hastily improvised men”—are not treated as such by Freud. Similarly the themes of depersonalization found in the Wolf Man—the “veil” that is torn during successive washings—are not referred to as such even though they are analyzed in depth (1918b [1914]). It is possible that it was only after the development of his concept of narcissism and the reorganization of the concept of the ego it contained that Freud became aware of depersonalization, in “The Uncanny” (1919h) and later in “A Disturbance of Memory on the Acropolis” (1936a). In both cases it is through feelings affecting the perception of the outside world that the topic is addressed, that is through the question of “derealization,” which can be considered the result of a type of depersonalization.

Paul Schilder was one of the first authors to take an interest in depersonalization. He saw it as a function of the libido’s withdrawal of cathexis from the image of the body. Paul Federn believed it corresponded to an alteration of the distribution of narcissistic libido throughout the body and its boundaries. Hermann Nunberg associated it with the loss of a significant object. Clarence Oberdorf emphasized the polymorphism of the clinical situations in which it could be observed and Andrew Peto investigated the role of the precocious loss of introjection. Maurice Bouvet, in an important study entitled “Dépersonnalisation et relation d’objet,” demonstrated the similarity of structure between states of depersonalization in their various clinical forms and treated “depersonalization as a state of weakened ego structure.” He insisted on the importance of a “rapprochement” with the object, that is a decrease in the creation of psychic distance to the object, whereby the object returns to the position it held in the subject’s unconscious fantasies. He also pointed out the character of the object relation that made it a narcissistic object since “the maintenance of the ego structure . . . depends on its unconditional and absolute possession.” Bouvet also noted the importance of the conflict between the need to introject the object and the fear of this introjection.

PAUL DENIS

*See also:* Boredom; Bouvet, Maurice Charles Marie Germain; Ego boundaries; Ego feeling; Estrangement; Face-to-face situation; Disintegration, feelings of, (anxieties); Rosenfeld, Herbert Alexander; Self-consciousness; Tomasi di Palma Lampedusa-Wolff Stomersee, Alexandra.

### Bibliography

Bouvet, Maurice. (1967). *Œuvres psychanalytiques. I: La Relation d’objet: névrose obsessionnelle, dépersonnalisation*. Paris: Payot.

Denis, Paul. (1981). J’aime pas être un autre. L’inquiétante étrangeté chez l’enfant. *Revue française de psychanalyse*, 65, 3.

Freud, Sigmund. (1919h). The uncanny. *SE*, 17: 217–256.

———. (1936a). A disturbance of memory on the Acropolis. *SE*, 22: 239–248.

Stewart, Walter A. (1964). Depersonalization. *Journal of the American Psychoanalytic Association*, 12, 171–186.

**Further Reading**

- Jacobson, Edith. (1959). Depersonalization. *Journal of the American Psychoanalytic Association*, 7, 581–610.
- Renik, Owen. (1978). The role of attention in depersonalization. *Psychoanalytic Quarterly*, 47, 588–605.
- Rosenfeld, Herbert. (1947). Analysis of a schizophrenic state with depersonalization. *International Journal of Psychoanalysis*, 28, 130–139.

**DEPRESSION**

Depression is a mood disorder, understood from the psychoanalytical viewpoint as resulting from an intrapsychic conflict that stems from the ego's difficulties in integrating aggressive drives that are experienced as too dangerous for the preservation of libidinally cathected objects. These aggressive drives turn against the subject via the superego, which becomes too strict and demanding. Depressive manifestations are frequent in other clinical entities where the conflicts are essentially intrapsychic, such as the psychoneuroses.

Karl Abraham (1912/1989) was one of the first psychoanalytical authors to concern himself with depressed patients and to describe the extent of the ambivalence of their drives. Narcissism is another characteristic of the depressive personality, which that Freud emphasized in "Mourning and Melancholia" (1916–17g [1915]). Subsequently, Abraham (1924/1927) described the pregenital underpinning of this ambivalence, given the importance of oral fixations in these patients.

Freud compared the psychological mechanisms of melancholia with those of mourning, which constitutes a depressive state in the normal person. The essential difference is the narcissism of the melancholic, whose intolerance of experiences of loss lead him to the oral incorporation of the lost object into the ego, where it is attacked by the superego. Conversely, the person in mourning finds himself faced with the painful difficulty of detaching the libido cathected onto the lost object so as to recathect it onto objects in the external world. However, the major problem raised by Freud's descriptions of the dynamics of melancholia is that he does not specify the variations in the psychological mechanisms corresponding to the different degrees of depressive states.

Melanie Klein (1940) developed the comparison with mourning in her description of the depressive

position. For her, the capacity to work through one's mourning will depend on the possibility of resolving the reactivation of the conflict proper to the depressive position that the conflict causes, i.e., the feeling of losing good internal objects. Klein, like Freud, is imprecise when it comes to the different problematics of depression. However, clinical analysis shows a whole series of levels of severity in this problematic between the working through of the mourning process (or during the integration of the depressive position) and the peak of this process, which Klein described as "a melancholia *in statu nascendi*" (Palacio Espasa). These depressive forms of conflict can be defined by reference to the predominant form of the fantasies expressing the experiences of the loss of the object of libidinal cathexis, and by the quality of the types of anxiety experienced by the ego.

When fantasies of the catastrophic and irreparable destruction of the object predominate, given that the subject has very little confidence in his libidinal capacities, feelings of guilt become intolerable and feelings of sadness are massively denied. The ego can only resort to archaic mechanisms of defense: splitting, denial, projective identification, idealization, etc.—the mechanisms proper to schizo-paranoid functioning or to the dynamics of extreme melancholia, with confusion between the ego and the object attacked (the "parapsychotic" depressive conflict proper to borderline or psychotic structures).

When fantasies of severe and barely reparable damage or death of the objects take the upper hand, the ego will be confronted with intense feelings of guilt and sadness. The significant repression of the aggressive drives towards the object (an aggressiveness that reinforces the severity of the superego) will make it possible for the negative affects to be partially denied. The ego will succeed in keeping the conflict interiorized but at the cost of diverse inhibitions in the functions of the ego. Thus, the symbolic possibilities of the individual are limited, but are not qualitatively affected. This very narrow form of repression is often insufficient, and the ego also has to resort to maniacal defenses or to defenses of a melancholic type, which then determine the clinical manifestations of mood disturbances.

When feelings of abandonment and rejection prevail—i.e., when the experiences of loss are above all fantasies such as the loss of the object's love—depressive conflict will take a "paraneurotic form."

The feelings of sadness are often conscious, for guilt is less intense and can equally easily become conscious. The ego's greater confidence in its libidinal capacities gives these subjects a profusion of fantasies of reparation that will counteract the damage done to the object, damage that is fantasized as resulting from their own aggressiveness. These fantasies underlie many of the neurotic mechanisms of defense, especially those of an obsessional kind, for example retroactive cancelling, reaction formation, etc. Under their influence, repression authorizes a greater possibility of symbolic expression, which distinguishes neurotic repression from the massive repression of the depressive type. Such a libidinal predominance changes the nature of what is repressed, for the counter-cathexis does not operate on aggressiveness alone, but also on the libidinal fantasies of an incestuous nature. This contributes to the sexual differentiation of parental objects, bringing into operation the conflict occasioned by triangulation and the Oedipus complex.

FRANCISCO PALACIO ESPASA

*See also:* Abandonment; Acute psychoses; Adolescent crisis; Anaclisis/anaclitic; Anxiety; Dead mother complex; Depressive position; Essential depression; Guilt, unconscious sense of; Identification; Internal object; Lost object; Manic defenses; Mania; Melancholia; Mourning; "Mourning and Melancholia"; Psychoanalytical nosography; Self-punishment; Suicide; Superego; Transference depression.

### **Bibliography**

- Abraham, Karl. (1927). The process of introjection in melancholia: two stages of the oral phase of the libido. In Douglas Bryan and Alix Strachey (Trans.). *Selected papers of Karl Abraham, M.D.* (pp. 442–452). London: Hogarth. (Original work published 1924)
- . (1927). Notes on the psycho-analytical investigation and treatment of manic-depressive insanity and allied conditions. In Douglas Bryan and Alix Strachey (Trans.), *Selected papers of Karl Abraham, M.D.* (pp. 137–156). London: Hogarth and the Institute of Psycho-analysis. (Original work published 1911)
- Freud, Sigmund. (1916–17g [1915]). Mourning and melancholia. *SE*, 14: 237–258.
- Klein, Melanie. (1940). Mourning and its relation to manic-depressive states. *International Journal of Psycho-Analysis*, 21, 125–153.
- Palacio Espasa, Francisco. (1993). *La Pratique psychothérapique avec l'enfant*. Paris: Bayard.

## **DEPRESSIVE POSITION**

A developmental stage in the first year allows the infant to begin to integrate his objects, which become mixed and take on both good and bad aspects. Particularly when the objects that attract ambivalent emotions are internalized, it creates a deeply troubling internal world, dominated by various forms of guilt feelings, sadness and reparative attempts to deal with them. (Melanie Klein, 1935).

Melanie Klein derived her notion of internal objects from the work that Abraham and Freud had done on the internalization of objects through oral incorporation in melancholia (Freud, 1917 [1915], Abraham, 1924). Abraham described symptoms which vividly expressed the movement of "loved objects" into and out of the body.

Klein (1935, 1940) viewed aggression from the earliest stages as producing a particularly problematic internal object. Freud described the internalization of the loved one as a response to its loss, when there was a particular heightened degree of ambivalence towards that person. In other words when a loved object, towards whom a lot of aggression is felt, is then lost, a persisting depression rather than normal mourning occurs. Klein discovered that this process also occurred with an *internal* object that was damaged (by the aggression) or, indeed, a dead internal object. It is this internal sense of damage and death which is the core experience of clinical depression, and was Klein's addition to Freud and Abraham's work on depression.

However, the depressive position (in contrast to depression) is a normal enough process. In this case, aggression, while internalizing loved objects, leads to restorative efforts towards the object internally, or in a symbolized and sublimated (and externalized) form. In turn, fears about the state of the internal object are always aroused by the loss of, or harm to, loved external objects.

Because of the love for a damaged or dead internal object the experience is extremely painful, and this anxiety of the depressive position has an internal reference point, known as guilt. During development the harshness of guilt is at first very severe, and is felt to be the retaliation of the damaged object inside—a phantasy that is in line with Freud's description of guilt arising from the superego. As a result the developing infant may have great difficulty in accepting these

feelings, and therefore hesitates to enter the depressive position. Crucially, the infant is anxious that its own badness and aggression will overwhelm its capacity for love. In this sense it is an intensely “moral” position, and indeed presupposes the struggle between love and hate as an inherent morality.

Klein and her followers found themselves in possession of the difficult notion of “internal objects.” This term refers to phantasies about the contents of the self, and especially the concrete contents of the body. This idea developed Abraham’s work on introjection and projection of objects which he found were phantasies of incorporation or expulsion of physical objects from the body (food and excreta). In Klein’s theory these objects are animate, and are motivated with good or bad intentions towards the ego, as if quite real homunculi were resident inside the person.

The developmental step—crucially the recognition that the loved person is also hated and attacked (at least in phantasy)—may be avoided for the time being by various specific defenses. Firstly, the infant may revert to more paranoid-schizoid states—the paranoid defense. Then the confluence of love and hate are prevented by continued splitting of good from bad objects.

Manic defenses are characteristic in the depressive position. Then, the importance of the loved object (and therefore its condition) is denied. As a result no serious guilt or dependence on the object is felt if it has been rendered so unimportant.

Alternatively if, and when, the guilt can be tolerated the ego is driven to seek methods of reparation for the damage done in phantasy or reality. In this case the harshness of the guilt, and the superego-like quality of the internal object becomes softened, and elements of forgiveness can develop.

The coming together of good and bad objects, and of the impulses of love and hate, mark the onset of a new respect for the reality of external people. Crucially, absence can begin to be tolerated without it being marked by a “bad object.” But the beginning of a transformation in many aspects of mental life and development are ushered in (Hinshelwood, 1994). No final solution to the depressive position problem is found, and the attempt to deal with aggression against objects that are also loved and depended upon is a slowly evolving thread all through life.

In many respects this developmental voyage based on object-relations supplants the progress through Freud’s libidinal phases. The achievement of reality testing (secondary process) is a comparable moment in development to that of the depressive position. Guilt is conceptualized in a slightly different way by Freud, as deriving from the strict superego (the only internal object that Freud attends to—Freud, 1923), and this contrasts with guilt from a damaged internal object in the theory of the depressive position.

For classical psychoanalysts, the notion of the depressive position and its place in the development of the infant, disregards the classical descriptions of the libidinal phases. In addition the early onset—in the first six months of life—is argued to be improbably early, for such a sophisticated set of emotional reactions. The integration that Melanie Klein described is then attributed to an age of two or three years when the mature Oedipus complex arrives.

However, for many non-Kleinian analysts a developmental scheme based on object-relations is compatible and complementary to the libidinal phases.

ROBERT D. HINSHELWOOD

*See also:* Alpha function; Ambivalence; Anaclitic depression; Archaic; Depression; Emotion; Fragmentation; Imago; Infant development; Infantile psychosis; *Learning from Experience*; Manic defenses; Melancholia; Neurosis; Oedipus complex, early; Paranoid position; Paranoid-schizoid position; *Psychoanalytic Treatment of Children*; Reparation; Selected fact; Splitting of the object; Symbolic equation; Thought-thinking apparatus.

### Bibliography

- Heimann, P. (1942). Sublimation and its relation to processes of internalization. *International Journal of Psycho-Analysis*, 23, 8–17.
- Isaacs Susan. (1940). Temper tantrums in early childhood and their relation to internal objects. *International Journal of Psycho-Analysis*, 21, 280–293. Republished in S. Isaacs (1948), *Childhood and after*. London: Routledge.
- Klein, Melanie (1935). A contribution to the psychogenesis of manic-depressive states. *International Journal of Psycho-Analysis*, 16, 145–174. Reprinted in *The writings of Melanie Klein*, vol. I. (1975). London: Hogarth, 262–289.
- . (1940). Mourning and its relation to manic-depressive states. *International Journal of Psycho-Analysis*, 21, 125–153. Reprinted in *The writings of Melanie Klein*, vol. I. (1975). London: Hogarth, 344–369.

## DEPRIVATION

Psychoanalytically, deprivation is the reduced fulfillment of a desire or need that is felt to be essential. Sigmund Freud (1927c) considered deprivation the result of the frustration of a drive that could not be satisfied because of a prohibition, and he was particularly interested in sexual deprivation. Later, psychoanalysis focused on the maternal deprivation caused either by the final or temporary absence of the mother or by her difficulty in providing primary care for the infant—a deprivation likely to have irreversible effects on the child's development.

For the infant, deprivation, as the result of an intrapsychic process related to needs or desires, assumes various forms. It is modulated by the reaction of the primary object, the mother, as well as the moment when the deprivation is produced, its duration, or even the attitude of mother substitutes.

The importance given to reality and its traumas compared to the reality of the representational world forms the basis of the differences among psychoanalytic theories. For example, psychoanalysts have studied the effects of “quantitative deprivation,” when the infant must confront the physical absence of the primary maternal object from birth, a condition known as hospitalism (Spitz, 1945), or after the establishment of a bond, a condition known as anaclitic depression (Spitz, 1946), which includes the phases of fright, despair, and separation. During these three phases, the infant is primarily searching for the lost anaclitic object, then, overcome with despair, enters into a situation of more or less pronounced denial, depending on the level of structuration of the internal object and the duration of separation. This process involves directing diffuse but unbearable aggressive impulses against the self, hatred of the incorporated internal object, and deprivation of the maternal breast accompanied by deprivation of the (oral) apparatus that would enable the infant to use it. Sometimes there is also a deprivation of all creative ability and the dissolution of the integrative process together with the inhibition or dissociation of impulses (Winnicott, 1984).

“Qualitative deprivation” has also been described, and occurs when the infant is presented with an object that prevents him from experiencing his impulses in an acceptable form because they are uncontrolled. This object does not assume the contradictory role of ensuring the satisfaction of the infant's needs and

pushing him toward autonomy and does not understand his signals or his thoughts. Operating behaviors and idealizing systems dominate this form of mother-child relationship (Kreiser, 1992) to prevent transient personal difficulties, struggles, and traumas from becoming mental pathologies, especially depressive and schizophrenic.

Forms of “mixed deprivation” are also known, where the interruption of maternal care and inadequate support are the basis of narcissistic collapse and weakness during the process of separation-individuation.

The effects of affective deprivation (Bowlby, 1951) have been studied among infants placed in institutions, hospitals, or foster homes (Winnicott, 1984), and in the context of family life. This has led to observation of depression and borderline and antisocial pathologies such as psychosis. Françoise Dolto has described the sudden and long-lasting dissociation found to exist following early hospitalization or repeated changes of care providers—without any possible reparation of the image of the body or the subject. The infant can regress to a state in which his vital needs are satisfied in a context where subtle, verbal, mimetic, or motor exchanges no longer take place. Having become autistic, the child's impulses no longer have an outlet and result in teratological symbolization through hallucination.

Léon Kreiser has studied depression (blank and empty) during periods of qualitative deprivation, especially their development on the psychosomatic level. Other authors have ascribed important narcissistic pathologies (feelings of emptiness, captive self-image, lack of confidence), along with the intolerance to frustration that provokes the transition to action, which is manifested during adolescence. Donald Winnicott has studied the dynamics of the antisocial act and the accompanying feeling of hopeful suffering. “In fact,” he writes, “deprivation does not deform the organization of the ego as in psychosis but pushes the infant to force the context to recognize the deprivation and ... the antisocial act manifests itself when the infant begins to create an object relationship and invest a person.”

GRAZIA MARIA FAVA VIZZIELLO

*See also:* Abandonment; Anaclisis/anaclitic; Analytic psychodrama; Breakdown; Developmental disorders;



Frustration; Hospitalism; Maternal care; Self-mutilation in children; Stranger; Transference depression.

### **Bibliography**

- Bowlby, John. (1951). *Maternal care and mental health*. Geneva: WHO Monographs.
- Kreisler, Léon. (1992). La prospettiva psicosomatica nella psicopatologia del lattante. In Fava, V.G., and Stern, D. (Eds.), *Modèles psychothérapeutiques au premier âge*. Paris: Masson.
- Spitz, René (1945). Hospitalism: an inquiry into the genesis of psychiatric conditions in early childhood. *Psychoanalytic Study of the Child*, 1, 53–74.
- Spitz, René. (1946). Anaclitic depression. *Psychoanalytic Study of the Child*, 2, 313–342.
- Winnicott, Donald W. (1984). *Deprivation and delinquency*. London: The Winnicott Trust.

### **Further Reading**

- Shengold, Leonard. (1989). *Soul murder: the effects of childhood abuse and deprivation*. New Haven: Yale University Press.
- Wilson, N. (2002). Depression and its relation to light deprivation. *Psychoanalytic Review*, 89, 557–568.
- Winnicott, Donald. (1984). *Deprivation and delinquency*. London: Tavistock.

## **DESEXUALIZATION**

“Desexualization” may be most easily understood through a discussion of its antonym, “sexualization” (Freud, 1905d). From an analytic point of view, sexualization is a response on the one hand to the endogenous imperatives of the sexual instinct and on the other to the exogenous imperatives of the encounter with the object and its otherness. The sex drive comes into play at the boundary of the biological body and the psyche, tracing signs of its libidinal energy on the body. The body then becomes “erogenous,” and bears the stamp of pleasure and unpleasure it experiences from encounters between a bodily source and a complementary object, the prime example of which is the encounter of mouth and breast.

The object, which is partial but complementary to the instinctual source, is present-absent as soon as mental life begins. Through its presence it participates in the experience of pleasure; its frustrating absence

will push the mental subject toward the initial hallucinatory experience, which, interacting with perception, will constitute the basic of ideation. Sexualization and objectification are coexistent and coalescent. Sexualization is both a manifestation and an effect of the sexual impulse that libidinally cathects the object in a way that is both quantitative and qualitative, as reflected in the strength and the emotional form of the object-cathexis.

In Freud’s first theory of the instincts, sexualization is subservient to and anaclitically dependent on the self-preservation that governs biological and mental life. Because of the paths taken by the object-libido, sexualization operates not only with respect to the object, but also with respect to the ego in the shape of the withdrawal of narcissistic libido. We may thus assume the existence of a desexualization of the object that goes hand in hand with the sexualization of the ego, and conversely.

If, for Freud, the sexual and the infantile are constitutive of the unconscious, it is strictly because of repression that they are preserved on this underlying level and separated from the conscious one. On the conscious level, the sexualizing activity of the psyche is not systematically apparent; signs of anticathexis and reaction formation may be discerned in manifest psychic contents that are desexualized while their latent inscriptions in the unconscious remain sexual. The gamut of psychic formations, including not only symptoms, be they hysterical, obsessive, or phobic, but also dreams, parapraxes, and slips, may appear to be “desexualized” yet betray, as compromise formations, latent sexual aspects that are accessible through free association. Childhood phobias are a case in point. The fear of a wild or domestic animal appears in the conscious mind as the repercussion of a traumatic event, associated with a concrete experience, but in fact it may be the transposed expression of, say, a guilty unconscious wish to have sexual relations with one’s mother. In that case it will also express a fear of castration by the father, which is experienced as the prohibition of that wish.

Desexualization can thus be viewed as a conscious mental process that leaves repressed sexualization intact in the unconscious. Whence the importance of the preconscious as a meeting ground, a place where desexualization—characterized by the repression of sexual impulses—and resexualization—arising from the return of repressed ideas attached to infantile sex-

ual activities and aroused during analysis by free association—can come together.

The Freudian concept of sublimation can help us understand the process of desexualization. It indicates a change of aim and object, which become social rather than sexual, and a shift from the pleasure principle to the reality principle. The sublimation of sexual impulses is associated with their plasticity; desexualization is in a way the precondition of access to socialization. Another psychic process, idealization, accounts for the transformation of the object, which, brought to perfection thanks to narcissistic projection, then becomes a model for identification.

The second theory of the instincts, and the second topography of the psychic apparatus that resulted from it, round out our understanding of the phenomena of desexualization. What is often called the great turning point of 1920 led Freud to rethink his instinct theory, taking into account a realm “beyond the pleasure principle” which he described in terms precisely consistent with the Nirvana principle, one of the basic tendencies of the psyche underpinning the compulsion to repeat and the push for a return to the inert and inanimate. Alongside the sexual instincts, therefore, and indeed pre-dating them, another category of instincts, the death instincts, now needed to be considered. This meant that a tendency to non-sexualization and to deobjectification was present from the beginning of the development of the mind, a tendency that could serve as a focal point for desexualization now conceived as a return to the inert and the inanimate, as a kind of paradoxical desire for non-desire. The Freudian conception of primal masochism proposes a fundamental psychic structure involving the coalescence of sexual and death instincts. Masochism is fundamentally the organizer of autoerotism as it is of narcissism, and it is at once the motor and consequence of instinctual fusion. As a sexualizing factor it may be a “guardian of life,” but it can also be lethal, fostering desexualization and leaving the field open, as it were, to the death instinct. The work of melancholy that is present, more or less, in every depressive situation, includes the effects of desexualization and deobjectification: the tendency to suicide represents the most extreme form of the desire for non-desire and the victory of the death forces characteristic of this ultimate form of desexualization.

The notions of sublimation and idealization were also changed and refined by Freud’s new conceptualization of instinctual dualism and of the functioning of

the mind. Processes of identification, and more specifically primary identification, now presupposed a desexualization that can facilitate the transmutation of object-cathexes into the new instinctual vicissitudes implied by sublimation and idealization.

Although in the analytic literature the term “desexualization” later received more systematic treatment by Heinz Hartmann in the context of the “desexualized ego,” as applied to adaptation to the social environment, it still seems important to distinguish clearly between a neurotic kind of desexualization characterized by repression of the sexual impulses, or by their sublimation and the idealization of the object, from a psychotic process engendered by the leveling effects of the death instinct on the sexual instincts.

In sum, as a result of the stimulation they represent relative to instinctual defusion, the psychic phenomena of desexualization are most clearly bound up, specifically, with the processes of unbinding, decathexis, and deobjectification; they also have a dialectical relationship with processes of identification.

MARC BONNET

*See also:* *Ego and the Id, The*; Ego autonomy; “On the History of the Psychoanalytic Movement”; *Self, the*; Sublimation; Superego.

### **Bibliography**

- Freud, Sigmund. (1905d). Three essays on the theory of sexuality. *SE*, 7: 125–245.
- . (1920g). Dr. Anton von Freund. *SE*, 18: 267 seq.
- . (1921c). Group psychology and the analysis of the ego. *SE*, 18: 65–143.
- . (1923b). The ego and the id. *SE*, 19: 12–59.

Hartmann, Heinz. (1964). *Essays on ego psychology*. New York, International Universities Press. (Original work published 1939)

### **Further Reading**

- Goldberg, Arnold. (1993). Sexualization and desexualization. *Psychoanalytic Quarterly*, 62, 383–399.

---

## **DESOILLE, ROBERT (1890–1966)**

Robert Desoille, a French engineer, psychotherapist, and creator of the concept of the “directed daydream,” was born on May 29, 1890, in Besançon, France, and

died on October 10, 1966, in Paris. Born into a family of military officers, Desoille studied engineering as a young man. In 1923 E. Caslant initiated him into an experimental technique of mental imaging, which he felt had psychoanalytic applications. He worked out his theory over the course of seven volumes.

In *Exploration de l'Affectivité Subconsciente par la Méthode du Rêve-éveillé* [Exploration of subconscious emotions using directed daydreams] (1938), he studied the relationship between symbolism, invention, and memory, demonstrating the advantages of his method for exploring sublimation. He built on the work of Pierre Janet, Sigmund Freud, Carl Gustav Jung, and Roland Dalbiez.

In *Le Rêve-éveillé en Psychothérapie* (The directed daydream in psychotherapy; 1945), he made reference to Jung's collective unconscious. For him, the psyche consists of two poles: the Freudian id and the self, which consists of the limit of what sublimation can obtain. The conscious ego shifts between the id and the self as a possible representation. In the directed daydream, transference is expressed and resolved.

In *Théorie et Pratique du Rêve-éveillé Dirigé* (Theory and practice of the directed daydream; 1961), Desoille moved toward a "rational psychotherapy" and developed a Pavlovian conception of neurosis. Through the directed daydream, he held, poorly adapted reflexes are dissolved and new dynamic stereotypes are formed, initially in the imagination.

Upon its appearance a number of authors—including Charles Baudouin, Gaston Bachelard, Juliette Favez-Boutonier, Françoise Dolto, and Daniel Lagache—took an interest in Desoille's work. Moreover, it has continued to generate commentary and further analysis since its introduction.

JACQUES LAUNAY

See also: Directed daydream (R. Desoille); Fantasy.

### Bibliography

Desoille, Robert. (1938). *Exploration de l'affectivité subconsciente par la méthode du rêve-éveillé: sublimation et acquisitions psychologiques*. Paris: J. L. d'Artrey.

———. (1945). *Le rêve-éveillé en psychothérapie: essai sur la fonction de régulation de l'inconscient collectif*. Paris: Presses universitaires de France.

———. (1961). *Théorie et pratique du rêve-éveillé-dirigé*. Geneva: Mont-Blanc.

———. (1971). *Marie-Clotilde. Une psychothérapie par le rêve-éveillé-dirigé: un cas de névrose obsessionnelle*. Paris: Payot.

———. (1973). *Entretiens sur le rêve-éveillé-dirigé en psychothérapie*. Paris: Payot.

## DESTRUDO

The Freudian concept of "destrudo" is one of a group of concepts that appeared fleetingly in Sigmund Freud's work and subsequently disappeared, although it is not always easy to identify the reasons for their disappearance. In the present case the situation is clearer since from an energy perspective Freud has always refused to postulate a "destrudo," that is, an energy specifically associated with the death drive, even though the term makes its appearance in *The Ego and the Id* (1923b).

Freud did not want to associate the duality of the drives with a duality of energies, since for him there was no energy dualism, but with a kind of energy monism, that of the libido. He subsequently abandoned use of the term "destrudo," which would have risked implying the existence of an energy dualism.

On several occasions Jean Laplanche has returned to this problem of terminology (1970, 1986). Destrudo does not appear in Jean Laplanche and Jean-Bertrand Pontalis's *The Language of Psychoanalysis*.

BERNARD GOLSE

See also: *Ego and the Id, The*; Death instinct (Thanatos); Libido; Weiss, Edoardo.

### Bibliography

Freud, Sigmund. (1923b). The ego and the id. *SE*, 19: 12–59.

Laplanche, Jean. (1970). *Vie et mort en psychanalyse*. Paris: Flammarion.

———. (1986). La pulsion de mort dans la théorie de la pulsion sexuelle. *La Pulsion de mort* (pp. 11–26). Paris: Presses Universitaires de France.

## DETERMINISM

The most general meaning of "determinism," one applicable in most contexts, is the condition of being

determined. If we understand determinateness to be a qualification of an object, determinism sees this determinateness initially as identification of the object (by several processes) and then as a causal response to a request for an explanation of why. All scientific or theoretical research thus necessarily presupposes determinism, but not in the sense of merely naming or the other operations of contemporary language, since the conditions for the initial application of language are not determinant. The meaning customarily given to determinism is determination, through the principle of causality, of the objective conditions for a phenomenon to occur.

Initially, the concept of determinism (*Determinismus*) arose within German theological and moral thinking, where it served narrow requirements related to predestination and was used to provide dogmatic answers; it did not have an objective theoretical meaning as such. Then in nineteenth-century scientific positivism, the “condition of determination” became associated with an empirical or descriptive principle of causality based on the primacy of observation, and not on explanation in the strict sense. Subsequently, for experimental science, determinism came to be considered a condition for the conduct of science itself, that is, as the epistemological principle of scientific knowledge. In this way determinism became normative. For example, physiological determinism claims to decide between the normal and the pathological in medicine, as shown by Georges Canguilhem.

Determinism, without being explicitly referred to, has been the ideal of mechanics since the seventeenth century. Projected onto objects made to satisfy the demand for causality, determinism ended up requiring that all phenomena satisfy the principle of ontological objectivity assumed in nature. Quantum physics, however, led to a retrenchment of this principle of establishing the conditions of determination, at least on the microphysical scale. Chaos theory has accentuated this point of view. In the sphere of the psyche, when Sigmund Freud attempted to explain dreams by psychoanalysis, he assumed a notion of psychic determinism in his theory of intentionality. He thus shifted the doctrine of causality in the direction of a theory of intentionality that assumed the existence of a subjective causality beyond or alongside objective causality, as shown by Pierre-Henri Castel in his introduction to Freud's *Interpretation of Dreams*.

Determinism essentially informs all theoretical or scientific research. So how can we explain the fact that

modern philosophical thought, at least since Kant and Fichte, is so strongly opposed to it? Natural determinism, after serving as the principle of Spinoza's immanent metaphysics, has come to dominate science. This domination reveals that the term has undergone both a confinement and an unwarranted extension in twentieth-century thinking. The confinement of the term to natural science constrains philosophers of freedom from examining the conditions that determine what they say. In the nonclassical sciences, confinement of the term to well-behaved natural sciences subjects intellectuals to indeterminacy complexes that seriously inhibit their theoretical inventiveness and subjects them to denigration. Freudian psychoanalysis, for example, is denigrated by positivist psychology and the various forms of psychological, organicist, and physicalist reductionism. As a result, Freudian psychoanalysis continues to search for an epistemological legitimacy based on theoretical models of the natural sciences, as was shown by Paul-Laurent Assoun. In physics, Max Planck and Werner Heisenberg created a quantum physics that was indeterminate from the point of view of classical determinism (as formulated by Pierre Simon Laplace). Because they were under the ideological spell of the old determinism, they could not completely accept their own discoveries as good science. There were two reasons for this situation: first, the concept of determinism arose not in the minimalist causal sense given above but in a theological sense, and second, ever since classical mechanics, the degree of determination that scientific objectivism has achieved has delimited the meaning and norm of determinism. Because they exclude identity and assume the differential nature of the symbolic, the status of the psyche and, even more so, the structuralist approach to the subject as taken by Jacques Lacan show that objective legality and causality could not serve as paradigms for everything we talk about. This is especially so for the unconscious, which, although “structured like a language,” is not structured as a determining cause.

A robust determinism must renounce naturalist metaphysics, which has continued to control its principles. A new philosophy of “determined” freedom can be developed without indeterminism. Freud's determined freedom led Jean-Paul Sartre, probably wrongly, to reject the Freudian unconscious and to confront a “natural determinism”. All of Freud's efforts, contrary to Jung's, clearly attempted to establish a paradoxical materialism that went beyond

philosophical idealism and the old materialisms, dialectic or otherwise.

DOMINIQUE AUFFRET

*See also:* Instinct; Neurosis, choice of the; Psychic causality; Psychogenesis/organogenesis; *Psychopathology of Everyday Life, The*; Complementary series.

### **Bibliography**

Assoun, Paul-Laurent. (1981). *Introduction à l'épistémologie freudienne*. Paris: Payot.

Castel, Pierre-Henri. (1998). *Introduction à "L'interprétation du rêve" de Freud*. Paris: Presses Universitaires de France.

Canguilhem, Georges. (1989). *The normal and the pathological* (Carolyn R. Fawcett, Trans.). New York: Zone Books.

Kojève, Alexandre. (1990). *L'idée du déterminisme dans la physique classique et dans la physique moderne*. Paris: Hachette. (Original work published 1932.)

Koyré, Alexandre. (1957). *From the closed world to the infinite universe*. New York: Harper.

Lacan, Jacques. (1966). *Écrits*. Paris: Seuil.

## **DETSKI DOM**

The Detski Dom (Children's Home, also known as the Solidarity International Experimental Home) was a kind of boarding school and experimental laboratory designed to help model the future "new man," the builder of communism. It opened in August 1921 in the center of Moscow and shared with the Psychoanalytic Institute the magnificent former home of Stepan Ryabushinsky. Though Ivan Ermakov, president of the Psychoanalytic Society and Institute, was officially responsible for the home, Vera Schmidt ran day-to-day operations. During a period filled with revolutionary ideas, in the broadest sense of the term, an attempt was made to merge Freudianism and Marxism. For many of Ermakov's friends this involved using psychoanalysis, "a powerful method of liberating man from his old reductive shackles," to create individuals who conformed to the ideals of the new society. At this time the new discipline of "pedology" was established.

Vera Schmidt ran the home on a theoretical, as well as practical, level. For Schmidt, an adept of Freud, early childhood was a critical period in the formation and evolution of the future adult. Accordingly,

children were admitted to the home between two and four years of age. Initially, the twenty-four residents were cared for by fifty-one staff members. The children lived there permanently, parents visiting only periodically. The residents came from various social backgrounds. They included Schmidt's son Volik (mistakenly referred to in some publications as Alik). After 1925 residents included many children of party bureaucrats, government officials, the Komintern, and even the youngest of Stalin's two sons, Vassili.

High-ranking visitors and inspectors found the environment pleasant; the staff calm, attentive, and considerate; the children clean and properly dressed; the rapport with teachers good; and the physical and psychological state of the children healthy. Moreover, in spite of external unrest, the home was well financed. Contributors included the State Department of Finance, the Union of Manual and Intellectual Workers of Germany (from which the name Solidarity International was derived), and some of the children's families. Otto Schmidt, Vera's husband and publisher of *The Library of Psychology and Psychoanalysis*, allocated a portion of the profits from the publishing house to the home.

Vera Schmidt organized periodic meetings of the teachers, who kept daily logs with detailed observations and prepared personal reports, diagrams, and graphs detailing the evolution of each child. Staff organized wake-up activities: drawing, découpage, modeling with clay, educational games. One of the purposes of the study was to examine infantile sexuality as well as various forms of impulse display.

Professional psychotherapists, including Sabina Spielrein, treated the children. Though Vera Schmidt did not have any psychoanalytic training, her publications on the experiment and the methods used at the home (which she herself translated into German) attracted high regard even from Anna Freud in Vienna, according to some sources. In early 1923 the Schmidts went to Vienna, where they met Sigmund Freud, Otto Rank, Karl Abraham, and other analysts.

Although the trip was successful (the Russian Psychoanalytic Society became a member of the International Psychoanalytic Association), back in Moscow the situation deteriorated for the home. The staff, with Vera Schmidt at its head, continued to request psychoanalytic training. United until then, the staff began to argue among themselves. In mid-1923 the number of

residents fell from twenty-four to twelve, and the staff was reduced to no more than eighteen members. The Solidarity International Experimental Home had to confront serious financial problems (exacerbated by the fact that assistance from Germany ceased). Moreover, the institution began receiving unfavorable publicity in the local press. In late 1923 and early 1924 a struggle broke out about the future of the Home. Several committees were dissolved and wild rumors circulated, most of which were based on an incorrect understanding of childhood sexuality. Aron Zalkind, the father of pedology and a Marxist-Freudian defector, wrote in 1926, “The sexual must be subjected to the class principle.”

Ideological resistance grew, and the home became its first victim, followed by psychoanalysis and pedology. Having become a nursery school, the institution had assumed an elitist character. On August 14, 1925, the Narkompros (Ministry of Public Education) ordered the experimental home closed. Later, during the 1930s, the house on Malaya-Nikitskaya Street became the personal residence of Maxime Gorky. Today the magnificent building houses the Gorky museum.

IRINA MANSON

See also: Marxism and psychoanalysis; Pedagogy and psychoanalysis; Russia/USSR, Schmidt, Vera Federovna.

### Bibliography

Etkind, Alexander. (1997). *Eros of the Impossible: The History of Psychoanalysis in Russia* (Noah Rubins and Maria Rubins, Trans.). Boulder, CO: Westview Press.

Palmier, Jean-Michel. (1982). La psychanalyse en Union soviétique. In Roland Jaccard (Ed.) *Histoire de la psychanalyse* (Vol. 2). Paris: Hachette.

## DEUTICKE, FRANZ (1850–1919)

Franz Deuticke, a Viennese publisher, was born on September 9, 1850, and died on July 2, 1919. In 1878 he and Stanislaw Töplitz took over the Viennese bookstore of Karl Czermak, together with the modest publishing house that was part of it. After Töplitz's departure in 1886, he became the sole owner of the Franz Deuticke Company. Using the funds from the bookstore, the company devoted its first years mostly to publishing books on medicine and the natural

sciences. Among the authors published were several professors from Sigmund Freud's university, including Theodore Meynert, Salomon Stricker, Max Kassowitz, and Heinrich Obersteiner. After having published a series of manuals and monographs in medicine and the natural sciences, Deuticke expanded his list between 1880 and 1890 to include scientific reviews and periodicals such as *Zentralblatt für Physiologie*, *Jahrbücher für Psychiatrie*, and *Monatsschrift für Kinderheilkunde*. Around this time he also became interested in the young science of economics.

After the turn of the century, Deuticke further broadened his publishing list to include scholarly books, law books, and psychoanalytic works. Freud's first contacts with Deuticke took place within the context of his own translation projects: the translation of Jean Martin Charcot's *Nouvelles conférences sur les maladies du système nerveux (Neue Vorlesungen über die Krankheiten des Nervensystems [1886])*, which appeared in 1886 and was included in volume one of the translation of the *Conférences polycliniques (Poliklinischen Vorträgen [1894])*, the translation of Hippolyte Bernheim's *La suggestion et son effet thérapeutique (Die Suggestion und ihre Heilwirkung [1888])* and Bernheim's *Nouvelles études sur l'hypnotisme, la suggestion et la psychothérapie (Neue Studien über Hypnotismus, Suggestion und Psychotherapie [1892])*. In 1891 Freud also entrusted the young and enterprising publishing house with his first monograph, *Zur Auffassung der Aphasien (On Aphasia: A Critical Study, 1891)*.

Until the outbreak of the First World War, Deuticke was, with rare exceptions, Freud's most important publisher, and his company can rightly be considered the first publisher of psychoanalysis. In 1895 Deuticke also published *Studien über Hysterie (Studies on Hysteria, 1895)*, written in collaboration with Josef Breuer, and in 1900, *Die Traumdeutung (The Interpretation of Dreams)*. On Freud's recommendation Deuticke also published some of Freud's scientist friends, such as Wilhelm Fliess, and later a number of psychoanalytic authors, such as Carl Gustav Jung. The company even took the risk of publishing the first psychoanalytic periodical: *Jahrbuch für psychoanalytische und psychopathologische Forschungen (1904–1914)*. To promote the new science, Freud became editor of the first series of works on psychoanalysis: *Schriften zur angewandten Seelenkunde (Writings on applied psychology)*.

At the start of the First World War, Hugo Heller positioned himself to be a publisher devoted to Freudian psychoanalysis, while Franz Deuticke Company, then run by Franz's son Hans, increasingly became a forum for publications by dissident psychoanalysts. After the war Deuticke published both Jung and, after his break with Freud, Otto Rank.

LYDIA MARINELLI

*See also:* Heller, Hugo *Imago. Zeitschrift für die Anwendung der Psychoanalyse; Interpretation of Dreams, The; Jahrbuch der Psychoanalyse.*

### **Bibliography**

Grubrich-Simitis, Ilse. (1996). *Back to Freud's texts: Making silent documents speak* (Philip Slotkin, Trans.). New Haven, CT: Yale University Press. (Original work published 1993)

Hall, Murray G. (1985). *Österreichische Verlagsgeschichte, 1918–1938*. Vienna: H. Böhlau.

---

## **DEUTSCH, FELIX (1884–1964)**

Felix Deutsch, psychoanalyst and physician, was born in 1884 in Vienna, and died on 1964 in Cambridge, Massachusetts.

Deutsch was educated at the University of Vienna. His family was Jewish and he developed firm Zionist convictions. In 1908 he became a doctor; internal medicine was always his specialty. Felix Deutsch met his future wife Helene, also a psychoanalyst, in Munich in 1911. Within a year they were married, and they remained married fifty-two years.

Deutsch had an artistic personality; he painted and composed, and was an excellent piano player. His musicality played a role in a contribution to psychotherapy that he made in America. He found he learned a lot about patients by provoking associations through repeating words, since tone had such meaning for him. As a therapist he learned to use his natural directness, and childlike inquisitiveness, to become an excellent interviewer.

Helene and their son moved to Boston in September 1935, and Felix joined them in early 1936. Between the fall of 1939 and the spring of 1941 Felix accepted an invitation to be the first professor of psychosomatic medicine at Washington University in St. Louis.

Felix grew increasingly confident within analysis, and back in Boston he attracted a number of devoted disciples. He also taught at the Smith College of Social Work. He was attracted by clinical possibilities other than strict analysis, and he hoped to be able to make a science of technique.

He published articles on psychosomatic medicine, and *Applied Psychoanalysis*, on the objectives of psychotherapy. Deutsch was one of the creators of psychosomatic medicine, and a leader in exploring new techniques of psychotherapy. He was also, for the period in 1923 when Freud first contracted cancer of the jaw, his personal physician.

PAUL ROAZEN

*See also:* Deutsch-Rosenbach, Helene; Wiener psychoanalytische Vereinigung.

### **Bibliography**

Deutsch, Felix. (1949). *Applied psychoanalysis: Selected objectives of psychotherapy*. New York: Grune and Stratton.

---

## **DEUTSCH-ROSENBACH, HELENE (1884–1982)**

Helene Deutsch, psychoanalyst and physician, was born October 9, 1884 in Przemysl, Poland, and died March 29, 1982 in Cambridge, Massachusetts.

Helene was the daughter of Jewish parents, but she grew up a Polish nationalist. Although formal schooling was impossible in Poland for a woman, private tutoring enabled her to enroll at the University of Vienna in 1907. From the outset she was interested in a psychiatric career. She received her medical degree from the University of Vienna in 1913.

As early as 1898 she was involved with a much older man who was a Social Democratic leader, Herman Lieberman. He was married, however, and a divorce in those days was politically out of the question.

While spending a year in Munich in 1910–11, studying with Emil Kraepelin, Helene finally broke off with Lieberman, who since 1907 had been a deputy from Poland in the Parliament at Vienna. In Munich she had met her future husband Felix Deutsch, and they were married in 1912. Women could not then hold clinical psychiatric appointments at the University of Vienna, but Professor Julius Wagner Ritter von Jauregg had

made a great impression on her. Once World War One broke out physicians were needed by the Austrian military, and Helene found new and welcome responsibilities thrust upon her. She functioned as one of Wagner-Jauregg's assistants, a post to which as a woman she could not formally be appointed. In the fall of 1918 Deutsch left Wagner-Jauregg's clinic in order to undertake a personal analysis with Freud, which lasted about a year. While for some, particularly Freud's exceptionally talented male pupils, he could be a burden to their independent development, Deutsch found that Freud released her most creative talents. She could write as Freud's adherent and at the same time fulfill her own needs for self-expression. She was not a mere imitator of Freud's, but within his system of thought she was able to express her own individual outlook.

The 1920s proved to be Deutsch's most creative period; she emerged as one of the most successful teachers in the history of psychoanalysis. In 1924 she became the first to head the new Vienna Psychoanalytic Training Institute, which meant that between 1924 and 1935 (when she left for Boston, MA) she had to assess all who came to Vienna for instruction in analysis. She was much sought after both as a training analyst and a supervisor; her seminars were remarkable experiences for students, and her classes were remembered as spectacles.

In Vienna Deutsch's case load became two-thirds American, and in 1930 she visited the United States to attend the First International Congress of Mental Hygiene. She was already looking around for a new position. One problem was the future possibilities of her husband Felix, an internist who had also been Freud's personal physician when he first contracted cancer in 1923. It turned out that Boston was the best place for the family, because a new psychoanalytic training institute was being founded there, and at the same time Dr. Stanley Cobb was creating a psychiatric department at the Massachusetts General Hospital. Cobb was interested in psychosomatic medicine, Felix's special field, so Cobb was eager to attract them both. Helene came over in the fall of 1935 with their son, and Felix arrived in Boston in early 1936.

Helene's stylishness, combined with the force of her personality, allowed her to attain a unique status in Boston. Many of the analysts involved in setting up the Boston institute had been her students abroad at a time when she was already one of Freud's favorites.

In 1925 Helene Deutsch became the first analyst to publish a book on the psychology of women. The

interest that she and Karen Horney showed in this subject prompted Freud, who did not like being left behind, to write a number of articles on women himself. Deutsch's insistence on the importance of maternity made her a pioneer.

At the end of World War II, she published her two-volume *Psychology of Women* (1944–45). She was especially interested in the conflict between maternal and erotic feelings in women, and she was acutely aware of how much she herself had missed in both realms. She felt that, in human terms, she had paid dearly for her professional commitment. Deutsch placed much emphasis, meanwhile, on the real conflicts of young women. Her works are heavy with the kind of cases one might expect never to see dealt with by a psychoanalyst. It was her view that in order to understand pathological behavior one must first have a clear idea of what normal behavior was like. For Deutsch, the fact that women had a more intense inner life meant that they were a unique source of human potential. Her best-known clinical concept was that of the "as-if" personality, a notion that allowed her to spotlight the origin of women's particular ability to identify with others. Her theories also helped her better understand her own ties to Freud and Lieberman.

In Deutsch's view, the crucial danger created by female masochism was that of victimhood, though the threat was potentially offset by the countervailing force of a healthy self-esteem. Horney criticized Deutsch's view of women, charging that she had fallen prey to biological reductionism through her neglect of social factors. Deutsch felt secure enough, however, to reply only in the most elliptical way. After all, she had held the fort in Vienna in the wartime, and her students had included the most notable among those of Freud's students who had remained loyal.

In 1973 Helene Deutsch published a set of memoirs, *Confrontations with Myself*, which constitutes an important testimonial to the history of Vienna and of the beginnings of psychoanalysis.

PAUL ROAZEN

*See also:* Maternal care.

### **Bibliography**

Deutsch, Helene. (1944–45). *The psychology of women*, Vols. 1 and 2. New York: Grune and Stratton.



- . (1967). *Neuroses and character types*. New York: International Universities Press.
- . (1973). *Confrontations with myself*. New York: W.W. Norton.
- . (1992). *The therapeutic process, the self, and female psychology*. (Paul Roazen Ed.) New Brunswick, NJ: Transaction.
- . (1994). *Psychanalyse des fonctions sexuelles de la femme*. Paris: Presses Universitaires de France.

## DEUTSCHES INSTITUT FÜR PSYCHOLOGISCHE FORSCHUNG UND PSYCHOTHERAPIE (GÖRING INSTITUTE)

The Deutsches Institut für Psychologische Forschung und Psychotherapie (German Institute for Psychological Research and Psychotherapy) in Berlin was the first independent institution for training in, research on, and practice in psychotherapy. It represented a significant realization of the aims of medical and nonmedical psychotherapists in Germany, an ethical capitulation to the threats and opportunities presented by the Nazi regime, and a controversial continuity of professional development into the postwar period.

The institute was founded in 1936 as a registered association under the supervision of the Ministry of the Interior. Its founding came about as a result of the desire of a number of psychotherapists in the German General Medical Society for Psychotherapy under Matthias Heinrich Göring to functionally unite the various schools of psychotherapy in an organization independent of the control of university psychiatrists and Nazi health activists, as well as the aim of the Nazi party and government to destroy the “Jewish” German Psychoanalytic Society without disposing of the practical benefits of psychoanalysis. Although officially dedicated to the creation of a *Neue Deutsche Seelenheilkunde* (New German Psychotherapy) in line with Nazi ideals and Germanic tradition, the so-called Göring Institute functioned more significantly as a locus for the development and application of generally short-term psychotherapeutic techniques in service to state, society, military, and business in Nazi Germany.

The institute was initially funded by the psychotherapists themselves, but in 1939 the German Labor Front assumed formal supervision over the institute and poured a great deal of money into its operations. This support was increasingly supplemen-

ted by money from the Luftwaffe (German Air Force) and from German industry and business. Individual psychotherapists and psychoanalysts also worked under the aegis of the SS (Schutzstaffel) and the Wehrmacht (German Army). In 1942 the institute became a member of the Reich Research Council, which, under the leadership of Herman Göring, was to mobilize science for the war effort. In 1944 followed the creation of the Reichinstitut für Psychologische Forschung und Psychotherapie im Reichsforschungsrat (Reich Institute for Psychological Research and Psychotherapy in the Reich Research Council), the final organizational manifestation of the Göring Institute. The institute came to an end in May 1945 with the end of the Second World War.

Psychoanalysts at the institute were prominent in the outpatient clinic inherited from the German Psychoanalytic Society. In teaching, training, and practice, the Jungians, Adlerians, and Freudians maintained a degree independence from each other. Most of the Freudians, out of a combination of preference and position at the institute, adopted a neo-Freudian emphasis on social adjustment and short-term therapy. Gerhard Scheunert was Göring’s first choice to head the clinic because of his expertise in short-term methods. The “neo-analysis” of Harald Schultz-Hencke was also influential. Many German analysts of the postwar period practiced and/or trained at the Göring Institute. Some, like Harald Schultz-Hencke, Felix Boehm, and Carl Müller-Braunschweig, were heavily criticized after the war for their involvement with a Nazi-sponsored entity.

Of all the groups at the institute, the psychoanalysts had the most political difficulty under Nazism because of their identification with Freud, a Jew. In 1938, as a protective measure in the wake of the November pogrom, their group was designated simply as “Work Group A.” With the arrest of outpatient director John Rittmeister in 1942, this group was formally dissolved and the psychoanalysts’ activities at the institute were further camouflaged.

GEOFFREY COCKS

*See also:* Germany Allgemeine Ällegemeine Ärztliche Gesellschaft für Psychotherapie; Berliner Psychoanalytische Poliklinik; France, Göring, Matthias Heinrich; Laforgue, René; Second World War; Müller-Braunschweig, Carl; Rittmeister, John Friedrich Karl; Schultz-Hencke, Harald Julius Alfred Carl-Ludwig.

### Bibliography

Cocks, Geoffrey. (1997). *Psychotherapy in the Third Reich: The Göring Institute* (2nd edition). New Brunswick, NJ: Transaction Publishers.

Lokot, Regine. (1985). *Erinnern und Durcharbeiten: zur Geschichte der Psychoanalyse und Psychotherapie im Nationalsozialismus*. Frankfurt am Main: S. Fischer.

### DEVELOPMENT OF PSYCHO-ANALYSIS, THE

In this book, conceived in 1922 and published in 1924, Sándor Ferenczi and Otto Rank were reacting against the practical fallout (transference and resistances in psychoanalytic treatment) from Freud's ideas on repetition compulsion and analysis of the ego.

According to the authors, the psychoanalytic movement gave in to a desire to claim to "know too much" and thus was diverted from its earliest "active" orientations. Psychoanalysts had developed incorrect technical precepts and were clinging to rigid or obsolete rules with regard to the transference.

The authors argued that the psychoanalyst's role is to "condition the unity of the process," to act as a catalyst for the transference, and to encourage repetition by partly playing the role of the parental imago. In this way, unconscious memory traces can finally be felt by the patient, transformed into "actual memories" (remembering/remembrance/recollection), and interpreted upon dissolution of the transference. It is *lived experience* that carries conviction, the true source of knowledge and the guarantee of therapeutic "effectiveness."

However, the analyst's "desire to learn and to teach," they held, led to errors in technique such as "fanaticism of interpretation" or seeking to confirm knowledge. By situating resistance on the side of the transference and the patient's narcissism, analysts increase the patient's unconscious guilt, masking their own difficulties in integrating negative transference and their narcissistic countertransference.

The future of the discipline, the authors said, depended on the "elimination of intellectual resistances." "Training analysis is in no way different from therapeutic analysis" and should not be reserved for medical doctors. Family physicians could be given special training (including hypnosis, provided it was better understood) that would contribute to mass

prophylaxis for psychiatric conditions. The authors emphasized therapeutic use of repetition in the transference, whereas Freud saw it above all as an obstacle to the process, since for him interpretation was the privileged therapeutic tool. This marked the beginnings of a schism.

Rank broke with the Committee. Ferenczi replaced his "active" method—based on an increase in tensions—with a principle of "laissez-faire" or "relaxation," which Freud opposed after 1930.

This book introduced ideas and controversies that were taken up by later authors (Michael Balint, Donald W. Winnicott, Harold F. Searles, Jacques Lacan): the therapeutic use of object relations and regression; the analyst's "discretion" (caution in interpretation); the analyst's resistances and the role of countertransference; interest in training for physicians; and the risks inherent in "training" analysis.

CORINNE DAUBIGNY

*See also:* Active technique; Counter-transference; Ferenczi, Sándor; Rank (Rosenfeld), Otto; Technique with adults, psychoanalytic; Training analysis; Training of the psychoanalyst.

### Source Citation

Ferenczi, Sandor, and Rank, Otto. (1925). *The development of psychoanalysis* (Caroline Newton, Trans). New York: Nervous and Mental Disease Pub. (Original work published 1924)

### Bibliography

Balint, Michael. (1968). *The basic fault: therapeutic aspects of regression*. London: Tavistock.

Ferenczi, Sándor. (1968). *Thalassa: a theory of genitality* (Henry Alden Bunker, Trans.). New York: Norton. (Original work published 1924)

Ferenczi, Sándor. (1926). Contra-indications to "active" psychoanalytical technique. In *Further contributions to the theory and technique of psycho-analysis* (J. Rickman, Comp. and J. I. Suttie, et al., Trans.). London: Hogarth.

Freud, Sigmund. (1920g). Beyond the pleasure principle. *SE*, 18: 1–64.

---

**DEVELOPMENT PROCESSES.** *See* Processes of development

## DEVELOPMENTAL DISORDERS

The term “developmental disorders” describes alterations in the normal process of development and any functional structures resulting from those alterations.

As early as *Studies on Hysteria* (1895d), Freud conceived of psychoneuroses as functional structures that had been altered by factors having a premature effect on the normal processes of psychogenesis. He thus developed a theory of the etiology of hysteria whereby psychic trauma (a sexual aggression) occurred at an early age but did not take full effect until puberty (1894a and 1896b). He also attributed a similar etiology to obsessional neurosis (1895c). After 1897 he admitted that the causative moment of a neurosis could equally well derive from fantasies or from real events, and he maintained throughout his work that the pathological structure thus constituted was explicable in terms of fixations and regressions. Three major clinical texts illustrate this thesis: Little Hans (1919b), The Rat Man (1919d), and The Wolf Man (1918b [1914]). Beginning in about 1908, he extended this system to the psychoses—which he considered to be narcissistic neuroses—despite certain theoretical difficulties, as witnessed by his conversations with Jung.

After Freud, psychoanalytical thinking spread particularly to the field of psychiatry and especially to infant and child psychiatry, which it contributed to creating. It would take a major comprehensive study to review the developmental disorders that psychoanalysis can envisage treating with one or another of its specific modes of action (whether a classic analysis, face-to-face psychotherapy, or psychoanalytic psychodrama), or with other modes of action (psychiatric, educational) guided by a psychoanalytical approach to the disorder. A classification of these developmental disorders is presented in *Traité de psychiatrie de l'enfant et de l'adolescent* (Treatise on child and adolescent psychiatry), edited by Serge Lebovici, René Diatkine, and Michel Soulé (1995), and the following is based on its main sections:

- Disorders resulting from disturbances in the early mother-child relationship: these disorders (particularly in cases of infantile autism or psychosis) from the pre-oedipal period affect the very foundations of personal identity and the development of a distinct, autonomous, and permanent Self.

- Symptomatic disorders of early childhood (disorders relating to sleeping, eating, and psychosomatic disorders such as infantile asthma): without excluding possible organic etiologies, these disorders should always be considered as the causes and effects of dysfunctions in the family structure and can, in serious cases, jeopardize the life of the baby.
- Disorders in psychological development resulting from dysfunctions of the motor or sensory systems that may be congenital or may have developed prematurely (epilepsy, cardiopathies, cerebral motor infirmities, blindness or amblyopia, deafness, etc.).
- Disorders with a neurotic structure (hysterical or obsessional functioning, states of anxiety): here we must distinguish between the “normal” infantile neurosis, resulting from the oedipal drama, and childhood neuroses that call for specific interventions. Many cases present a more localized symptomatology, to be considered in the context of neurotic organization: persistent bed-wetting, eating disorders, language problems and problems with fine motor skills, intellectual inhibitions (which can be mistaken for mild or moderate mental handicaps), academic phobias or failure, etc.
- Borderline states and psychopathic structures (Misès, 1990). Perverse structures are rare in children; in adolescents and adults they indicate serious disorders in the processes of identification and must be understood in the light of the subject's history.
- Finally, many disorders in children can be understood in terms of deprivation or serious alterations in the environment, primarily in the family (premature separation from the mother, alcoholism and/or sexual aggression by the father, maltreatment); even in the absence of a pathological condition in the parents, problems relating to adoption or medically assisted procreation may justify the intervention of a psychoanalyst. In all these cases, even more than those previously mentioned, it is the whole family, over and above the individual subject, that needs to receive care.

In this entire field, but no doubt more so in cases that strike us by their severity (infantile autism, for instance), there are controversies and polemics that

oppose psychoanalysts (and those who speak in their name, sometimes making outrageous claims) and organicists intent on ignoring the specifically psychic and relational dimensions of the issue in question.

Reconstructing the subject's past remains one of the major pathways in the psychoanalytic approach to disorders. Dysfunctions in the present structure of a given person are analyzed with reference to the developmental stages of that structure and by referring to a model of normal development.

The practice of analyzing children has greatly contributed to defining such developmental models. It is worth noting in this regard that some authors (André Green) criticize the use in certain developmental models of an ad hoc "fictitious baby" and stress structure (synchronic organization) rather than history (diachronic).

ROGER PERRON

*See also:* Abandonment; Adolescent crisis; Autism; Autistic capsule/nucleus; Deprivation; Identity; Infantile psychosis; Prematureness; Prepsychosis; *Three Essays on the Theory of Sexuality*.

### **Bibliography**

Freud Sigmund. (1894a). The neuro-psychoses of defence. *SE*, 3: 41–61.

———. (1895c). Obsessions and phobias: Their psychological mechanism and their aetiology. *SE*, 3: 69–82.

———. (1896b). Further remarks on the neuro-psychoses of defence. *SE*, 3: 157–185.

Lebovici, Serge, Diatkine, René, and Soulé, Michel. (1995). *Nouveau traité de psychiatrie de l'enfant et de l'adolescent*. Second edition. Paris: P.U.F.

Misès, Roger. (1990). *Les Pathologies limites de l'enfance*. Paris: P.U.F.

### **Further Reading**

Tyson, Phyllis & Tyson, Robert. (1990). *Psychoanalytic theories of development: An integration*. New Haven/London: Yale University Press.

---

## **DEVEREUX, GEORGES (1908–1985)**

Georges Devereux, an ethnopsychanalyst, was born György Dobo on September 13, 1908, in Transylvania, Hungary, and died in Paris in 1985. His ashes were

dispersed according to Mohave funeral rites in Parker, Arizona. Dobo assumed the name Georges Devereux in 1932, the same year he converted to Catholicism. He spent his childhood and adolescence in Lugos (Transylvania), his birthplace, which was annexed by Romania in 1919. He was the youngest of three children; the eldest committed suicide during adolescence. Devereux's family was well off and cultivated, polyglot, and riven with conflicts. His pro-German mother systematically objected to the pro-French sentiments of the rest of the family.

Devereux displayed considerable musical talent as a child, both as a pianist and composer, and he wrote poetry. He left Bavaria for Paris in 1926, frequented Parisian literary circles, and formed friendships with a number of famous individuals among them, including Klaus Mann. In 1927 he published poems and essays, written in German, in French avant-garde journals like Eugène Ionesco's *Transitions*. He oscillated between lifestyles and professions: bookseller, writer, physicist, chemist, mathematician, sociologist, ethnologist. In Paris during the early thirties, he studied with Marcel Mauss and Lucien Lévy-Bruhl, and then with Alfred Kroeber at the University of California, Berkeley. From there he left on his first expedition to live among the Mohave Indians, to whom he remained emotionally and scientifically attached. The following year he traveled to the high plateaus of Indochina to study the Sedang Moi (1933–1935).

His experiences in the field led him to psychoanalysis and transcultural psychiatry in 1938. Ethnopsychanalysis and ethnopsychiatry developed in response to the cultural relativism of the time. Devereux was in Paris at the end of the Second World War, where he served in the U.S. navy, and began his own psychoanalysis with Marc Schlumberger. After returning to the United States, he worked with Karl Menninger at the Menninger Clinic at the University of Kansas at Topeka, from 1946 to 1953. Indian veterans suffering from traumatic neuroses were his patients. He practiced psychoanalysis and became a member, in 1952, of the International Psychoanalytic Association (IPA) and the Philadelphia and New York Psychoanalytic Societies. He taught at Temple University in Philadelphia.

Devereux returned to Paris in 1963. He became a member of the Société Psychanalytique de Paris in 1964, and taught ethnopsychiatry and psychoanalysis

at the École des Hautes Études en Sciences Sociales and, occasionally, at Oxford University.

Devereux's published works comprise more than four hundred contributions. His articles, reports, and monographs range from a detailed descriptive approach to the psychopathology and therapeutic practices of the Mohave and Sedang peoples, to the psychoanalytic interpretation of Greek mythology, to considerations of the mental disturbances of Western societies, and the methodological difficulties in the social sciences. He was in contact with American anthropologists, including Margaret Mead and Ralph Linton, but never abandoned his analytic approach. He introduced methodological concepts such as "complementarity" and "transculturalism" and opened new fields of investigation by integrating psychoanalytic, psychiatric, ethnological, and mythological explanations.

SIMONE VALENTIN

See also: *Basic Problems of Ethnopsychiatry*.

### Bibliography

Devereux, Georges. (1953). Cultural factors in psychoanalytic therapy. *Journal of the American Psychoanalytic Association*, 1, 4, 629–655.

———. (1970). *Essais d'ethnopsychiatrie générale*. Paris, Gallimard.

———. (1985). *Ethnopsychanalyse complémentariste*. Paris, Flammarion. (Original work published 1972)

———. (1978). L'ethnopsychiatrie. *Ethnopsychiatrica* 1, 1, 7–13.

Devereux, Georges; and Simon, Bennett. (1976). *Dreams in Greek tragedy. An ethno-psychoanalytical study*. Berkeley, Los Angeles: University of California Press.

Hook, R. (Ed.) (1979). *Fantasy and symbol; studies in anthropological interpretation, essay in honor of George Devereux*. London: Academic Press.

## DIATKINE, RENÉ (1918–1997)

René Diatkine, a French psychiatrist and psychoanalyst, was born on April 6, 1918, in Paris, where he died on November 2, 1997. He was born into a Russian Jewish family (from the region of Vitebsk) that emigrated to France during the early part of the twentieth century. He began studying medicine in 1939 and continued through World War II, during which he was

mobilized twice. When not on active duty, he lived in Marseille, where he established his first significant professional contacts, most notably with Rudolph Loewenstein.

In 1946, as soon as the war was over, Diatkine became a physician and trained in psychiatry and psychoanalysis in Paris, where he settled permanently. He worked as an intern, then as a senior psychiatrist at the children's hospital Hôpital Necker des enfants malades in Professor Georges Heuyer's department. During this period he met Julian de Ajuriaguerra, with whom he opened a practice to treat language and motor disturbances. He and Ajuriaguerra also worked together to open a center for observing children, where they collaborated with language educators and psychomotor and language trainers. At the same time, Diatkine began his analytic training, undergoing analysis with Jacques Lacan. He became an associate member of the Société psychanalytique de Paris (Paris Psychoanalytic Society) on June 26, 1951, and a full member on July 1, 1952, after having resumed analysis with Sacha Nacht. He participated in the critical dialogue that expanded the field of French psychiatry, which until then had been restricted to asylums. It was at this time that Diatkine established what were to become the key interests of an extremely active career.

In 1958, together with Serge Lebovici and Rosine Crémieux, he established the journal *La psychiatrie de l'enfant* (Psychiatry of the child). That same year, with Serge Lebovici, Philippe Paumelle, and others, he founded the Association de santé mentale (Mental Health Association) in Paris. There in 1963 he helped establish the Centre Alfred-Binet, a psychoanalytic institution for children.

In 1972 Diatkine, together with Julian de Ajuriaguerra and Serge Lebovici, founded a children's line as part of the series *Le fil rouge*, published by Presses universitaires de France.

In Geneva and Paris, Diatkine helped develop a system of adult care for schizophrenic patients. In Geneva he was appointed associate professor in 1972, then part-time professor, and finally honorary professor in 1991. He continued to lead seminars until 1995.

In addition to his institutional commitments, Diatkine was active in the Paris Psychoanalytic Society. In 1953 he became director of the Centre de consultations et de traitements psychanalytiques (Center for

Psychoanalytic Consultation and Treatment) of the new Institut de Psychanalyse in Paris. That same year he participated in supervisory committees of the International Psychoanalytical Association, working to spread the use of psychoanalysis in Spain and Portugal. In 1964, under the auspices of the Paris Psychoanalytic Society, he instituted the annual Deauville Colloquium, known after his death as the René Diatkine Colloquium. In 1968 he was president of the Paris Psychoanalytic Society and remained active in its teaching committees and candidate training programs.

In 1982, with Marie Bonnafé, he founded Actions culturelles contre les exclusions et les ségrégations (Cultural Activities to Counter Exclusion and Segregation), a unique organization providing access to books to children and parents living in marginalized or poor communities. That same year Diatkine created *Les cahiers du Centre Alfred-Binet* (Journal of the Alfred Binet Center).

Diatkine wrote extensively: his list of publications includes more than four hundred titles. From the 1950s he progressively developed his ideas. Since then his approach was recognized as highly different, even though his work was still influenced by contemporary neuropsychology, especially the research of Julian de Ajuriaguerra. His work helped establish foundations for a new form of child psychoanalysis. His book *La psychanalyse précoce* (Precocious psychoanalysis; 1972), written in collaboration with Janine Simon, remains an important text on child psychoanalysis. In it he developed his notion of the role of primal fantasies. Several of his studies were significant for the evolution of French psychoanalytic thought after World War II: “Étude des fantasmes chez l’enfant” (Fantasies in children), in collaboration with Serge Lebovici (1954), “Aggressivité et fantasmes d’agression” (Aggression and aggression fantasies; 1964), “Rêve, illusion et connaissance” (Dreams: illusion and understanding; 1974), “Introduction à une discussion sur le concept d’objet en psychanalyse” (Introduction to a discussion of the object in psychoanalysis; 1989).

While maintaining his individual practice, Diatkine developed original techniques for expanding the application of psychoanalysis: individual psychodrama, collaboration with teams of multidisciplinary caregivers, techniques of language reeducation, field work, coordinated programs involving teachers and librarians. He explained how links between the nor-

mal and the pathological could be used to escape overly rigid classifications, questioned the “ravages of fate,” and worked to reestablish the historical continuity that dissolves during a difficult adolescence. Emphasizing latent mental potential, he insisted on the possibility of psychic reorganization, and transmitting, rather than teaching, the richness and discipline of psychoanalytic thought; he fought against reductionism.

FLORENCE QUARTIER-FRINGS

*Notion developed:* Prepsychosis.

*See also:* Aggressiveness/aggression; Centre Alfred-Binet; Centre de consultations et de traitements psychanalytiques Jean-Favreau; Character neurosis; Child psychoanalysis; France; Indications and contraindications for psychoanalysis for an adult; Maternal reverie, capacity for; Société psychanalytique de Paris et Institut de psychanalyse de Paris; Stammering; Technique with children, psychoanalytic.

### Bibliography

- Aguirre Omar, José-Maria, and Guimon Ugartechea, José. (1994). *Vie et œuvre de Julian de Ajuriaguerra*. Paris: Masson.
- Bonnafé, Marie. (1994). *Les livres c’est bon pour les bébés*. Paris: Calmann-Lévy.
- Diatkine, René. (1964). Aggressivité et fantasmes d’agression. Paris: Presses Universitaires de France.
- . (1974). Rêve, illusion et connaissance. *Revue française de psychanalyse*, 38 (5–6), 769–820.
- . (1989). Introduction à une discussion sur le concept d’objet en psychanalyse. *Revue française de psychanalyse*, 53 (4), 1037–1043.
- Diatkine, René, and Simon, Janine. (1972). *La psychanalyse précoce*. Paris: Presses Universitaires de France.
- Lebovici, Serge, and Diatkine, René. (1954). Étude des fantasmes chez l’enfant. *Revue française de psychanalyse*, 18 (1), 108–155.
- Lebovici, Serge, Diatkine, René, and Soulé, Michel. (1985). *Traité de psychiatrie de l’enfant et de l’adolescent*. Paris: Presses Universitaires de France.
- Quartier-Frings, Florence. (1997). *René Diatkine*. Paris: Presses Universitaires de France.

---

**DIFFERENCES.** *See* Narcissism of minor differences

## DIPSOMANIA

The term “dipsomania” was used in clinical psychiatry. It is not a psychoanalytic term but was used on occasion by Sigmund Freud and other psychoanalysts. The classic definition of “dipsomania” is that of Valentin Magnan (1893): Preceded by a vague feeling of malaise and a burning sensation in the throat, dipsomania is a sudden need to drink that is irresistible, despite a short and intense struggle. The crisis lasts from one day to two weeks and consists of a rapid and massive ingestion of alcohol or whatever other strong, excitatory liquid happens to be at hand, whether or not it is fit for consumption. It involves solitary alcohol abuse, with loss of all other interests. These crises recur at indeterminate intervals, separated by periods when the subject is generally sober and may even manifest repugnance for alcohol and intense remorse over his or her conduct. These recurring attacks may be associated with wandering tendencies (dromomania) or suicidal impulses. Although “dipsomania” means compulsive thirst, the use of the term is reserved for the compulsive intake of alcoholic beverages.

The term was introduced by Dr. C. W. Hufeland in 1819 in his preface to *Trunksucht* (Dipsomania), a study of the phenomenon by C. von Bruhl–Cramer. Even as early as 1817 the Italian physician Salvatori had identified a “furor to drink.” All of these authors contrast dipsomania and chronic alcoholism.

Freud alluded to dipsomania in his correspondence with Wilhelm Fliess (Freud to Fliess, January 11, 1897, and “Draft K”) and in his “Further Remarks on the Neuro-Psychoses of Defence” (1896b). He saw dipsomania as a secondary symptom of a defense against an obsessive thought that forms when the compulsion is displaced from that thought onto the motor impulses directed against the thought. In more exact terms, the compulsion, emanating from the ego, is mobilized against the affects linked to the obsession, as a measure of protection against and desensitization to suffering induced by these affects and as a means of obtaining pleasure. This need for alcohol is a substitute for an associated repressed sexual activity of an autoerotic kind, namely masturbation, which Freud, in a letter to Fliess dated December 22, 1897, calls “the one major habit, the ‘primal addiction’ ” (1950a [1887–1902], p. 272). The drunken stupor represents both a desensitization of the ego to painful affects and the pleasure of active mastery of experiences of passivity. Motor

acts (drinking, whether or not associated with dromomania) are central to the obsession.

In a letter of January 11, 1897, Freud cited the case of “a man of genius” who “had attacks of the severest dipsomania from his fiftieth year onwards” and who was “a pervert and consequently healthy” until that point (1950a [1887–1902], p. 240). The man’s crises were heralded by catarrh, hoarseness, and diarrhea (“the oral sexual system”), all of which represented bodily “reproduction of his own passive experiences” and brought together desensitization, repetition, and mastery. Freud compared this substitution of compulsive drinking for the sexual instinct to the substitution that culminates in the passion for gambling. In this letter to Fliess, Freud outlined an intergenerational psychopathology. During the same period he published, in succession, “Heredity and the aetiology of the neuroses” (1896a) and “Sexuality in the aetiology of the neuroses” (1898a).

There is little elaboration of this notion in Freud’s subsequent writings. However, in considering epileptic fits and pathological gambling as they relate to (autoerotic) sexuality and death in “Dostoevsky and Parricide” (1928b), Freud provided, without designating them as such, insights into the alcoholic’s crises: “He never rested until he had lost everything” (p. 191). “The irresistible nature of the temptation, the solemn resolutions, which are nevertheless invariably broken, never to do it again, the stupefying pleasure and the bad conscience which tells the subject that he is ruining himself (committing suicide)—all these elements remain unaltered in the process of substitution” (p. 193).

In this essay Freud proposes the hypothesis of an abnormal mechanism of discharge of the instincts, posited organically, that operates both in histolytic or toxic brain disease and in cases of inadequate control over the psychic economy when energy levels reach a certain threshold. This mechanism is closely related to the sexual processes, understood as “fundamentally of toxic origin” (p. 180), and enables the ego to “get rid by somatic means of amounts of excitation which it cannot deal with psychically” (p. 181). The meaning and intentionality of such crises (drunkenness, coma, or deep sleep) are well known: Such “deathlike” (p. 182) states express an identification with a dead person, in either reality or fantasy, the latter being more significant (boys, in their fantasies, usually wish for the death of the father). The dipsomania crisis,

preceded by an aura of supreme happiness, liberation, and triumph, has a punitive value: the subject is dead, like the person the subject wished dead. This is similar to the situation of the brothers of the primitive horde and relates to totemic ritual.

In the view of Otto Juliusburger (1913), dipsomaniacs who seek out the company of “lower-class” drunks in this way demonstrate their subjection to sadomasochistic instincts. Edward Glover (1932) compared dipsomania to an obsessive ceremonial (less obvious in solitary drinkers) and saw it as an “artificial” manic-depressive syndrome (with more direct sadism and a less severe oral fixation). Similarly, Otto Fenichel (1945) saw a link between pathologically impulsive characters and “the ego’s morbid syntonic impulses,” expressed on the economic and dynamic levels as manic-depressive disorders characterized by alternating acts and remorse. These impulses are seen as (futile) attempts to master old experiences through repetition and active dramatization, to master guilt, depression, and anxiety. John W. Higgins (1953) and William J. Browne (1965) emphasize the passage from thought to motor action, a return to the mother, an incorporation of the mother’s breast, and denial of passivity. For Charles Melman (1976), aversion therapies that seek to create new boundaries are actually aggravating factors in dipsomania. In an observation based on just two interviews, Jean-Paul Descombey (1992) relates the case of a young dipsomaniac who engages in a repetitive ritual of a “tournament of grand dukes” with his various brothers and sisters, begun from when he discovered the body of his dead mother; autoerotism and the death instinct are condensed in the subject’s comment “I must finish myself off.”

The notions of somalcoholosis (P. Fouquet, 1955) and alcoholism (Edmund Jellinek) are synonymous with dipsomania. Alcoholepsy, or alcoholic seizures (P. Fouquet, 1970) is a critical episode in a chronic alcoholic; associated forms of dromo-dipsomania have been described. Bulimic behaviors, which are comparable to dipsomania, are sometimes associated with it. Alimentary orgasm (Sándor Radó, 1933), which has a euphoric pharmacogenic effect, is provoked by the ego, which thus rediscovers its broadest narcissistic dimension.

The relative dearth of studies of dipsomania is explained by the fact that dipsomaniacs are often approached only in single interviews in hospital

emergency rooms, where they tend to end up; there is rarely any follow-up. Nevertheless, as a particular form of alcohol abuse, dipsomania is of interest in that it involves a kind of epitome and condensation of various aspects of alcoholism: a compulsion for repetition; a short-circuiting of psychical working through by acting out an undeclared depressive state; the problematic interplay of desensitization and attempted mastery; and autoerotism and self-destructive, potentially lethal actions. There are two possible dangers here: overdistinguishing dipsomania from other forms of alcoholism and, alternatively, failing to perceive its specificity. The same is true for transitory alcohol abuse and drunkenness in “normal” subjects, which are insufficient in and of themselves to account for alcohol addiction, whether or not dipsomania is present. A dynamic approach must go beyond organicist views, which attempt to link dipsomania to manic-depressive psychosis or epilepsy, and take into account the connections suggested in clinical practice. Finally, Freud, in “Dostoevsky and parricide” (1928b), though he does not explicitly cite alcoholism (from which Dostoyevski himself was not immune), nevertheless proposes a toxicity-based theory of sexuality and the neuropsychoses (Descombey, 1994).

JEAN-PAUL DESCOMBEY

*See also:* Addiction; Alcoholism.

### **Bibliography**

- Browne, William J. (1965). The alcoholic bout as an acting out. *Psychoanalytic Quarterly*, 34, 420–437.
- Descombey, Jean-Paul. (1992). Alcoolisme: dépression ou addiction? *Information Psychiatrique*, 68, (4), 338–345.
- . (1994). *Précis d'alcoologie clinique*. Paris: Dunod.
- Fenichel, Otto. (1945). *The psychoanalytic theory of neurosis*. New York: Norton.
- Freud, Sigmund. (1896b). Further remarks on the neuropsychoses of defence. *SE*, 3: 162–185.
- . (1928b). Dostoevsky and parricide. *SE*, 21: 177–196.
- . (1950a [1887–1902]). Extracts from the Fliess papers. *SE*, 1: 173–280.
- Glover, Edward. (1932). On the aetiology of drug addiction. *International Journal of Psycho-Analysis*, 13, 298–328.



Magnan, Valentin. (1893). *Leçons cliniques sur les maladies mentales: état mental du dipsomane* (2nd ed.). Paris: L. Bataille.

Mijolla, Alain de, and Shentoub, Salem A. (1973). *Pour une psychanalyse de l'alcoolisme*. Paris: Payot.

Radó, Sándor. (1926). The psychic effects of intoxication: attempts at a psychoanalytic theory of drug addiction. *International Journal of Psycho-Analysis*, 7, 16.

## DIRECT ANALYSIS

Direct analysis is a therapeutic technique developed by John Rosen for the treatment of schizophrenics. Rosen began from the basic postulate that serious pathologies have their origins in inadequate or poor maternal care. As the result of such care, the patient is psychically a baby and must be treated as such, with unconditional love from a caregiver. This led Rosen in some cases to assume the nearly continuous care of a single patient for several weeks, and sometimes several months, while actively trying to shake up or pierce the patient's defensive shell through so-called "direct" interventions (including violent physical contact).

Rosen's position was appealing because of its optimistic slant (its assumption that if the therapist does not know where he is going, the patient's unconscious would), because of the courage and sacrifice required of the therapist (whose personal life was thereby relegated to the background), and without doubt because of the generous but obviously simplistic nature of the etiological theory involved. At its most extreme, Rosen's technique is not so very different from that proposed by Sándor Ferenczi before Freud convinced him to abandon it. Yet on a theoretical level, Rosen's theory obviously misinterprets the central role of conflict in psychic pathology, and on a practical level, his technique ignores the obvious risks of uncontrolled counter-transference.

ROGER PERRON

*See also:* Schizophrenia.

### **Bibliography**

Rosen, John. (1953). *Direct analysis*. New York: Grune and Stratton.

## DIRECTED DAYDREAM (R. DESOILLE)

The notion of the directed daydream refers to a product of the imagination, an expression of a waking oneiric state, used in the 1930s by Robert Desoille for therapeutic purposes; he later gave it the name *directed daydream* (or *directed waking dream*).

The directed daydream is an active mobilization of the imagination in a relaxed setting by means of suggestions of climbing and descending, for the purpose of exploring "subconscious affectivity" and gaining access to the "superior part of the mind that is not exclusively colored by instinct." Imaginary space appears in this context as a metaphor for mental space. The approach's theoretical development extends from Freudian sublimation (1938) to a Pavlovian conception of the search for new, dynamic stereotypes (1961), by way of a Jungian mobilization of archetypes (1945).

At the beginning of the 1970s, practitioners of the directed daydream technique in the Groupe International du Rêve Eveillé en Psychanalyse (GIREP; International group of the directed daydream in psychoanalysis) integrated the Freudian unconscious into their practice and theory. This gave rise to an analytical practice known as the "directed daydream in psychoanalysis." This involved allowing images to form as spontaneously as possible, creating an imaginary space based on the idea of moving or traveling, describing to the analyst the scenes that unfold, and having the patient describe his associated feelings. Treatment comprised two inseparable and interactive elements: producing the directed daydream and putting it into words, and the associative work of exploring its meaning in relation to memories, nocturnal dreams, and fantasies; constructions and interpretations operated on a metaphorical level. Psychoanalytic in its reference to the unconscious and to various Freudian and post-Freudian concepts, this treatment is distinctive in terms of its procedures and its view of the therapeutic relationship, according to which the dynamics of the directed dream treatment imply analysis of the transference. Among the approach's main theoretical orientations are the following:

- Nicole Fabre, for whom the space of the directed daydream, a joint creation, facilitates the expression of old problem areas and partakes of sublimation in the Freudian sense.

- Roger Dufour, who emphasizes the specular function of the directed daydream: the patient works on the relationship between speech, the body, and the Imaginary—a relationship that is basic to mental dynamics.
- Gilbert Maurey, who locates the directed daydream at the metaphorical boundary between the Imaginary and the Symbolic as a mediator for access to the unconscious, the treatment being worked out in terms of the Real-Symbolic-Imaginary triad.
- Jacques Launay, who emphasizes the role of movement in the imaginary space and its ability to invigorate the primary process.
- Jean Guilhot and Marie-Aimée Guilhot, who describe the directed daydream as an instrument for change through the visualization of reparative or innovative experiences within an analytic and transpersonal perspective.

JACQUES LAUNAY

See also: Desoille, Robert.

### Bibliography

- Dufour, Roger. (1978). *Écouter le rêve. Le Rêve-éveillé-dirigé analytique. Écoute et repères de l'Inconscient. Poésie et mythe en psychanalyse*. Paris: Robert Laffont.
- Fabre, Nicole. (1985). Les voies et les fins d'une analyse R.E.D. *Le Rêve-éveillé-analytique*. Toulouse, France: Privat.
- Guilhot, Jean, and Marie-Aimée Guilhot. (1987). *Analyse, activation et action thérapeutique. Vers un intégralisme analytique et prospectif*. Paris: E. S. F.
- Launay, Jacques. (1983). Le Rêve-éveillé et l'Inconscient. *La Serrure et le Songe*. Paris: Economica.
- Maurey, Gilbert. (1995). *Le Rêve-éveillé en psychanalyse. De l'imaginaire à l'Inconscient*. Paris: E. S. F.

## DISAVOWAL

The term “disavowal” (*Verleugnung*), often translated as “denial,” denotes a mental act that consists in rejecting the reality of a perception on account of its potentially traumatic associations. The notion of disavowal made its appearance rather late in Freud’s work. For years he was content to describe the little boy’s refusal to recognize the absence of a penis in a little girl, as observed in clinical practice, without employing a

specific term. Thus, in his “On the Sexual Theories of Children” (1908c) and in the case history of “Little Hans” (1909b), he noted the phenomenon and described it in terms of a rejection of perceptual evidence. Little boys, he argued, do not doubt “that a genital like [their] own is to be attributed to everyone [they] know. . . . This conviction is energetically maintained by boys, is obstinately defended against the contradictions which soon result from observation, and is only abandoned after severe internal struggles (the castration complex).” The period concerned, lasting approximately from three to five years of age, Freud dubs the “phallic stage” in view of the narcissistic hypercathexis of the idea of the penis by which it is usually characterized—especially in the little boy, who finds it unthinkable that anyone worthy of respect should be without a penis, least of all his mother.

The little girl cannot similarly reject the perception of her own lack of a penis. However, in certain young girls, Freud notes “the hope of some day obtaining a penis in spite of everything and so becoming like a man may persist to an incredibly late age and may become a motive for strange and otherwise unaccountable actions.”

Freud’s first reference to the term was in the “Wolf Man” case history (1918b [1914]; see also 1914a), where he conceived of disavowal as operating between at least two regions of the ego which invalidated one another. Thus one region might accept the symbolic character of castration and sexual difference while the other embraced the all-or-nothing logic of the phallic structure, and everything proceeded as though the two spheres had no influence upon each other at all.

Beginning with the *Introductory Lectures on Psychoanalysis* (1916–17a), Freud began systematically using the verb *verleugnen* to refer to the mental act of rejecting a perception as inconceivable—which James Strachey translated as “to disavow.” The noun form—*die Verleugnung* (disavowal)—was not used to designate the metapsychological concept until a little later (1925h). It was mainly in his late work, in “A Short Account of Psychoanalysis” (1940a [1938]) and “The Splitting of the Ego in the Process of Defense” (1940e [1938]), that Freud sought to anchor the specificity of disavowal by situating it within the particular topography of the split ego.

In “The Infantile Genital Organization” (1923e), Freud reasserted that only the male organ played a

significant role in the mind of the child of either sex around three years of age. The child could understand the absence of a penis only as the result of castration. It was therefore the manner in which the initial disavowal was overcome that determined the castration complex to which the individual would become subject. Returning to this crucial question in “Psychical Consequences of the Anatomical Distinction between the Sexes” (1925j), Freud presented castration as a result of a “deferred action,” the threatening nature of the possible absence of the penis assuming its full mental force only after a more or less extended period of disavowal.

Freud also noted that the persistence of such disavowal beyond the phallic period, into adolescence and adulthood, could lead to a form of mental illness: “The process I would like to describe as denial [*Verleugnung*] . . . appears to be neither rare nor very dangerous for the mental life of the child, but in adults it could lead to psychosis.”

Moreover, Freud had published two observations of young men in whom denial of the lack of a penis appeared to determine the outbreak of psychotic symptoms (1914a). The first was the famous “Wolf Man,” whom Freud claimed had “dismissed” [*verwarf*—see “Foreclosure”] the “reality [sic] of castration,” that he “refused to know anything about it, in the sense of repressing it. He did not actually pass judgment as to whether it existed or not, [castration] but effectively it did not.” This rejection, as inconceivable, of the possible absence of the penis was what triggered the patient’s returning hallucination of a severed little finger. For Freud, then, the psychotic ego disavowed perceptual reality in a way somewhat akin to the way a neurotic repressed certain instinctual demands.

But Freud subsequently went on to broaden his clinical work on disavowal well beyond the realm of psychosis. In “Fetishism” (1927e) he reported a case of two young men each of whom denied the death of his father. However, Freud notes, neither of them developed a psychosis, even though a “a piece of reality which was undoubtedly important has been disavowed [*verleugnet*], just as the unwelcome fact of women’s castration is disavowed in fetishists.”

He then returned to the notion of the splitting of the ego (already discussed in the Wolf Man case history), presenting it as the topographical corollary of

the mechanism of disavowal: the possible juxtaposition in the psyche of at least two incompatible mental attitudes that appeared to have no influence on one another. It was no longer a question, therefore, of treating disavowal as the disavowal “of” something but rather as a mutual disavowal, a disjunction “between” two discrete realms of the split ego. Similar disavowals were common, Freud noted, and not merely among fetishists. In his later works Freud maintained that disavowal was present to varying degrees in psychosis, perversion, and very possibly too in all normal subjects. He offered an instance from his personal experience in a public letter to Romain Rolland (“A Disturbance of Memory on the Acropolis,” 1936a, p. 245).

It was also in his paper on “Fetishism” that Freud showed that disavowal, unlike repression, did not erase the idea or perception in question but only its meaning; this was why he rejected the term “scotomization” proposed by René Laforgue (1927e, pp. 153–54). Disavowal was in fact a suspension of the function of judgment, of that same attributing judgment he felt was decisive in the formation of the ego. As a consequence of his methodological concern more clearly to distinguish disavowal and repression, he ended by suggesting that repression treated the affect as disavowal treated the idea, which may be taken to mean that repression no more eliminates the affect (it is only displaced) than disavowal erases the idea (whose meaning alone remains obscure).

This having been said, it is important to recognize that all the clinical illustrations of disavowal supplied by Freud over a thirty-year period are based on two canonical illustrations: the disavowal of women’s lack of a penis and the disavowal of the death of the father. Disavowal is thus always a disavowal of absence, which is why it is so important in the process of symbolization. In fact, Freud specifies as a prerequisite of symbolization the ability to represent the object to oneself as something that can be absent: an object, he says, can only be symbolized in absentia. The disavowal (of absence) therefore constitutes a fundamental obstacle to the very process of constructing psychic reality, and in this it is quite distinct from negation, which operates as the starting point of the (preconscious) mental recognition of something: disavowal and negation are radically different in their logical functions.

Disavowal, as opposed to negation, is a narcissistic expedient whereby the individual seeks to avoid

acknowledging absences or shortcomings of key parental figures (castration of the mother, death of the father). In practice, however, it transpires that persistent disavowal hardly allows the subject to overcome the traumatic burden of the representations in question; indeed the potential latent virulence of these representations appears rather to be made permanent by the invalidation of possible symbolic links. Moreover, whatever suffering disavowal and splitting may spare the subject's consciousness is generally proportionately visited upon those around him.

In the treatment of patients afflicted by enduring disavowal, everything suggests that they want to leave the responsibility of thinking what is for them unthinkable, of integrating what they cannot integrate, up to the "other" member in the therapeutic relationship. This occurs primarily through the mechanism of projective identification, which requires considerable psychic expenditure on the part of that other person, often within a very painful experiential realm. This kind of detour through the mental economy of the therapist is seemingly a necessary but not sufficient condition for the subject's successful integration of such elements into a symbolic interplay thanks to which the pleasure principle can again become effective.

Jacques Lacan in his seminar on "Object Relations" (1956–1957), talks about disavowal (he uses the French "*démenti*") as a fundamental mechanism of the so-called perverse structure, with its characteristic manner of treating castration: simultaneously rejecting and accepting it. He employs the term "foreclosure" to refer to the mechanism of symbolic denial, which he feels is a key factor in psychosis.

BERNARD PENOT

*See also:* Fetishism; Negative, work of the; Repudiation.

### **Bibliography**

- Freud, Sigmund. (1909b). Analysis of a phobia in a five-year-old boy ("Little Hans"). *SE*, 10: 5–147.
- . (1914a). Fausse reconnaissance ("déjà raconté") in psychoanalytic treatment. *SE*, 13: 201–207.
- . (1918b [1914]). From the history of an infantile neurosis. *SE*, 17: 1–122.
- . (1925j). Some psychical consequences of the anatomical distinction between the sexes. *SE*, 19: 241–258.

———. (1927e). Fetishism. *SE*, 21: 147–157.

———. (1936a). A disturbance of memory on the Acropolis. *SE*, 22: 239–248.

———. (1940e [1938]). Splitting of the ego in the process of defence. *SE*, 23: 271–278.

Lacan, Jacques. (1956–1957). *Le séminaire-livre IV, la relation d'objet*. Paris: Le Seuil.

---

## **DISCHARGE**

An economic term borrowed from a physicalist epistemological model, "discharge" was used by Sigmund Freud in his theorization of how the psychic apparatus deals with excitation. The notion of discharge thus refers to an outward release of the energy produced in the psychic apparatus by excitations, whether these are external or internal in origin.

By virtue of its economic orientation, this notion is part of the metapsychological approach and speaks to the quantitative dimension in Freud's model. Freud discussed discharge when he described the pleasure/unpleasure principle: the pleasure of discharge, the unpleasure of retention. We should recall that according to Freud, the source of the instinct is a state of excitation in the body and its *aim* is to eliminate this excitation. Obviously, the concept of discharge implies as a corollary the notion of tension, or charge. Pleasure and unpleasure probably depend less upon an exact level of tension than upon the rhythm of variation in tension. The principle of pleasure/unpleasure is thus considered a particular case of Gustav Fechner's "tendency toward stability," that "tendency" becoming in this instance the "principle of consistency."

Consistency is said to be achieved by means of the discharge of the energy already present, but also by the avoidance of factors that might increase the quantity of excitation. The principle of consistency is indeed basic to Freud's economic theory and is closely linked with the pleasure principle. The psychic apparatus, in this view, also tends to cancel out excitations or reduce them to a minimum, and Freud, following Barbara Low, called this the "Nirvana principle," which works in tandem with the principle of inertia. It is in this realm that the forces of Thanatos lurk; moreover, it was in *Beyond the Pleasure Principle* (1920g), where the death instinct is introduced, that Freud explicitly formulated the principle of consistency and related it to the Nirvana principle.

Discharge can be total or partial; it can be appropriate or it can contribute to psychopathological, even psychodramatic disorders. The notion thus appears in Freud's discussions of "abreaction" or "acting-out," when there is insufficient regulation of excitation by the psychic apparatus. Another possibility is discharge into the body, which suggests the mysterious leap from the psychic to the somatic, the notion of somatic compliance, and the phenomenon of conversion. Freud also mentioned the pathogenic role of defective discharge in considering the model of actual neurosis, and in presenting the hypothesis of the damming up of the libido to explain the phenomenon of hypochondria. Still in the context of discharge, the soma as an internal safety-valve has been viewed as a way of handling tensions that cannot be worked through or that are too massive—in short, a kind of somatic "acting-in."

ALAIN FINE

*See also:* Cathartic method; Emotion; Excitation; Free energy/bound energy; Fusion/defusion of Instincts; Pleasure/unpleasure principle; Primary process/secondary process; Principle of constancy; Psychic energy; Quantitative/qualitative; Reality principle; Repression; Thought; Trauma; Unpleasure; Working through.

### **Bibliography**

- Freud, Sigmund. (1914c). On narcissism: an introduction. *SE*, 14, 67–102.
- . (1920g). Beyond the pleasure principle. *SE*, 18, 1–64.
- . (1926d [1925]). Inhibitions, symptoms and anxiety. *SE*, 20, 75–172.
- Marty, Pierre, et al. (1968) Le cas Dora et le point de vue psychosomatique. *Revue française de psychanalyse*, 32, 4.

## **DISINTEGRATION, FEELINGS OF (ANXIETIES)**

The expressions *feelings of disintegration* and *disintegration anxieties* refer to a feeling of extreme anxiety that the personality is "falling to pieces" or disintegrating into elements that are no longer connected together. This serious form of depersonalization has been described in the psychoses, particularly schizophrenia. It has been mainly evoked, however, with regard to the earliest stages of the infant's development and their consequences.

Following Melanie Klein's description of the schizoid-paranoid position in "Notes on Some Schizoid Mechanisms" (1946), the notion of fragmentation appeared in theoretical descriptions and psychoanalytic clinical practice to characterize the anxieties inherent in that position. Under the influence of the death drive, and introjected in the form of the persecutory breast or penis, archaic defenses produce a major splitting of the self considered in terms of bad internal objects. This defensive mechanism is accompanied by feelings of destruction, annihilation, or fragmentation of the ego that have been interpreted by some as a precursor to castration anxiety. Linked to deprivation, privation, and frustration, only the introjection of a good object can restore the cohesion of such a fragmented self, by creating a path toward the depressive position.

These psychopathological notions have been taken up by Kleinian authors such as Donald Winnicott, although in his case greater importance is granted to the environment, particularly the mother. Esther Bick returned to the notion of fragmentation through her observations of infants, and Wilfred R. Bion makes it a constant, to varying degrees, of the psychotic part of all personalities, with the ever-active threat of "catastrophic change."

Pierre Marty describes another form of fragmentation in his work on "essential depression," and Heinz Kohut views it as one of the main elements in the pathologies of the self. Jacques Lacan, meanwhile, reverses the Kleinian positions by viewing the archaic anxieties of the "fragmented body" as the consequence of castration, which is by definition inscribed within the real from the beginning.

*See also:* Anxiety; Breast, good/bad object; Castration complex; Essential depression; Foreclosure; Fragmentation; Paranoid-schizoid position; Privation; Psychotic part of the personality; Schizophrenia.

### **Bibliography**

- Klein, Melanie. (1975). Notes on some schizoid mechanisms. reprinted 1975 in: *The writings of Melanie Klein* (Vol. 3, 1946–1963, p. 1–24). London: Hogarth. (Reprinted from *International Journal of Psycho-Analysis*, 27: (1946), 99–110.)
- Kohut, Heinz. (1971). *The analysis of the self*. New York: International Universities Press.
- Lacan, Jacques. (1962–63). *Le séminaire-Livre X: L'angoisse*. Unpublished.

## DISINTEGRATION PRODUCTS

A psychoanalytical theory founded on the development of the Self postulates a stage of development at which its integration is achieved. This stage is characterized by a subjective feeling of continuity in time and space, and simultaneously by an ease of communication between body and mind. Before one reaches this stage, there is the psychological equivalent of separate zones of operation, characterized by distinct zones of pleasure and activity. A return to this previous stage of disparate activity amounts to a form of disintegration: any integration already achieved is undone. This disintegration is manifested by the emergence of isolated activities that are non-communicative and unlinked and involve isolated parts of the body, pleasure felt in one isolated zone, and an isolated ideational preoccupation. This can take various forms: hallucinatory thoughts, repetitive motor activity and/or hypochondriacal ruminations. This phenomenon can assume alarming dimensions, but it can easily be overcome by means of a rapid reintegration brought about by a connection, described as a Self-object relation, which serves to restore this temporarily lost state of cohesion.

From this point of view, the appearance and disappearance of psychotic symptomatology can be explained by the shift from an integrated Self to the emergence of products of disintegration. The particular cause of this regressive movement is some form of narcissistic wound: in other words, it stems from wounds to the Self that are serious enough to produce a downward spiral involving fragmentation. The appearance of products of disintegration in the course of psychological treatment is considered to be the result of the loss of a Self-object, which is the equivalent of a break in the Self/Self-object relation—a break which is in turn experienced as a narcissistic wound.

ARNOLD GOLDBERG

*See also:* Fragmentation; Self-object.

### Bibliography

Kohut, Heinz. (1977). *The restoration of the self*. New York: International Universities Press.

## DISMANTLING

The term *dismantling*, introduced by Donald Meltzer, refers to a very primitive defense mechanism involving

dissociation of the perceptual apparatus “by a passive process that allows the various senses, specific and general, internal and external, to attach to whatever object is most stimulating at the moment” (Meltzer, 1975/1991)—for example, a light, a sound, or an odor.

Meltzer used this term for the first time in a paper delivered at a meeting of the British Psychoanalytical Society in June 1969, “The Origins of the Fetishistic Plaything of Sexual Perversions” later published in his second book, *Sexual States of Mind* (1973, pp. 107–113). He took the idea of the dismantled object from the psychoanalytic treatment of children who had suffered from early infantile autism. He defines dismantling as “the most primitive working of obsessional mechanisms” (p. 108). Unlike the splitting processes described by Melanie Klein, which make use of the sadistic drives, dismantling, which is reversible at any time, instead relies on a relaxation of the attention function.

The author invented this term with reference to the notion of “consensual validation” defined by Harry Stack Sullivan, which is very close to Wilfred R. Bion’s idea of the “common sense.” Meltzer’s proposed idea involves a dissolution of such constructions, leading to the creation of a multitude of unisensory objects. He emphasizes that the implementation of such a defense mechanism suppresses genuine relational experiences and thus their introjection. In the first publication, he hypothesizes that dismantling is also seen in sexual perversions where the exciting objects (fetishes) are “dismantled objects” used in their purely sensorial aspect.

The notion of dismantling is then taken up in greater detail in Meltzer’s 1975 book *Explorations in Autism*, where he shows the massive use of this defense mechanism in autism proper, explaining the stereotypes of sensory autostimulation under the influence of the repetition compulsion. He demonstrates a more complex use of this phenomenon in postautistic obsessiveness and in obsessional states in general. Meltzer argues that dismantling, which is beyond consensuality or within its dissolution, does not belong to the spectrum of projective identification but rather belongs within the notion of “adhesive identity” positing a two-dimensional space, proposed by Esther Bick (1975).

Some French authors (J. Bégoïn, 1994; D. Ribas, 1994; D. Maldavsky, 1995) have compared dismantling to decahexis in the Freudian sense, and it is indeed possible to do so: The former can be considered as a very primitive form of the latter. Dismantling also

seems to be at work in the self-soothing behaviors described by Claude Smadja (1993) and Gérard Szweç (1993). These authors compare this mechanism with the abnormal, destructive primary masochism that Benno Rosenberg (1991) describes as “centered around excitement in and of itself . . . and the gradual abandonment of the object.” Frances Tustin also shares this view in *Autistic States in Children* (1981), in which is described an autosensuality, differentiated from autoerotism, in autistic maneuvers and its exacerbation into self-directed sadism in certain cases.

GENEVIÈVE HAAG

*See also:* Autism; Autistic defenses.

### **Bibliography**

- Bégoïn, Jean. L'être, l'espace et le temps: les travaux de D. Meltzer sur l'autisme (1975). In Roger Perron and Denys Ribas (Eds.), *Autismes de l'enfance* (pp. 91–114). Paris: Presses Universitaires de France.
- Bick, Esther. (1986). Further considerations on the functioning of skin in early object relations: Findings from infant observation integrated into child and adult analysis. *British Journal of Psychotherapy*, 2, 292–299.
- Meltzer, Donald. (1990). *Sexual States of Mind*. Perthshire, Scotland: Clunie Press. (Original work published 1973)
- Maldavsky, David. (1995). A propos du noyau autistique précoce chez l'homme aux loups. *Journal de la Psychanalyse de l'enfant*, 17, 125–142.
- Meltzer, Donald, et al. (1991). *Explorations in Autism*. Perthshire, Scotland: Clunie Press. (Original work published 1975)
- . (1973). *Sexual states of mind*. Perthshire, Scotland: Clunie Press.
- Ribas, Denys. (1994) Repérages métapsychologiques dans l'autisme infantile. In Roger Perron and Denys Ribas (Eds.), *Autismes de l'enfance* (pp. 129–147). Paris: Presses Universitaires de France.
- Rosenberg, Benno. (1991). *Masochisme mortifère et masochisme gardien de la vie*. Paris: Presses universitaires de France.
- Smadja, Claude. (1993). Á propos des procédés autocalmants du Moi. *Revue française de psychosomatique*, 4, 9–26.
- Szweç, Gérard. (1993). Les procédés autocalmants par la recherche répétitive de l'excitation (les galériens volontaires). *Revue française de psychosomatique*, 4, 27–51.
- Tustin, Frances. (1981). *Autistic states in children*. London: Routledge.

## **DISORGANIZATION**

The concept of disorganization is not specifically Freudian. It is part of a semantic field that constitutes one of the contemporary currents of psychoanalysis, namely the psychosomatic economy of Pierre Marty. It refers to a set of mental transformations, which at each step cause the psychic apparatus to lose its structures of meaning and reduce its capacity for impulse expression.

We find similar concepts in Freud, primarily in his work on actual and traumatic neurosis. In 1894, in Manuscript E on anxiety (1950a), and in 1895, in his article, “Detaching a Syndrome of Anxiety Neurosis from Neurasthenia” (1895b), he created a new classificatory entity, anxiety neurosis, for which he provided a clinical description and formulated a psychological hypothesis. His hypothesis involves a breakdown in the connection between somatic sexual excitation and “thing representations” in the unconscious. The first anxiety theory postulates the accumulation of somatic sexual excitation. Among the psychic obstacles to somatopsychic communication, Freud gives three possible mechanisms: repression, the difference between somatic sexuality and psychic sexuality, and degradation (of the libido). This last mechanism can be compared to the concept of disorganization. In 1920, in his essay, *Beyond the Pleasure Principle* (1920g), Freud developed his economic hypotheses concerning traumatic neurosis. He states that, faced with the traumatic irruption, “Cathectic energy is summoned from all sides to provide sufficiently high cathexes of energy in the environs of the breach. An ‘anticathexis’ on a grand scale is set up, for whose benefit all the other psychical systems are impoverished, so that the remaining psychical functions are extensively paralysed or reduced” (p. 30).

Since Freud we have come to understand actual neurosis as one of the modalities of traumatic neurosis, and its psychoanalytic study is a major component of the analysis of psychosomatic behavior.

In 1967, in an article titled “Régression et instinct de mort: Hypothèses à propos de l'observation psychosomatique,” Marty systematically described for the first time the two major processes of somatization: the path of regression and the path of progressive disorganization. While the process of somatization through regression culminates in reversible “crises,” the process of somatization through progressive disorganization

leads to progressive illnesses that can result in death. This last process is supported, according to Marty, by the action of the death instinct and is generally accompanied by depression and an externalized mode of existence.

In *Les mouvements individuels de vie et de mort* in 1976 and in *L'ordre psychosomatique* in 1980, Marty situated the concept of disorganization within the general framework of his theory of individual evolution, which refers to the counter-evolutionary movement caused by the precedence of the death drive over the life drive. This apparent precedence is generated by a traumatic context that has an impact on what is generally the psychic organization of character. The process of disorganization is generally made possible by the lack of points of fixation capable of serving as psychic and somatic obstacles. Consequently, the concept of disorganization is distinct from that of regression, with its points of fixation, or attachment.

CLAUDE SMADJA

*See also:* Disintegration, feelings of, (anxieties); Essential depression; Mentalization; Psychogenesis/organogenesis; Psychosomatic; Regression; Traumatic neurosis.

### Bibliography

- Freud, Sigmund. (1895b). Detaching a syndrome of anxiety neurosis from neurasthenia. *SE*, 3: 0–115.
- . (1920g). Beyond the pleasure principle. *SE*, 18: 7–64.
- . (1950a [1887–SE, 1: 173–280].
- Marty, Pierre. (1967) Régression et instinct de mort: Hypothèses à propos de l'observation psychosomatique. *Revue française de psychanalyse*, 30, (5–6), pp. 1113–1126.
- . (1976). *Les Mouvements individuels de vie et de mort, vol. I, Essai d'économie psychosomatique*. Paris: Payot, "Sciences de l'homme."
- . (1980). *Les Mouvements individuels de vie et de mort, vol. II, L'Ordre psychosomatique*. Paris: Payot, "Sciences de l'homme."

## DISPLACEMENT

For Freud, displacement (a primary process) means the transference of physical intensities (1900a, p. 306) along an "associative path," so that strongly cathected ideas have their charge displaced onto other, less

strongly cathected ones. This process is active in the formation of hysterical or obsessional symptoms, in the dream work, in the production of jokes, and in the transference.

Between 1887 and 1902 the concept of displacement appeared several times in Freud's writings (in Drafts K and M in his correspondence with Wilhelm Fliess, in the "Project for a Scientific Psychology" [1950c (1895)], and in *The Interpretation of Dreams* [1900a]). It was introduced in connection with his clinical work, apropos of the analysis of neurotic symptoms and paranoia. In Draft M (1950a), Freud described the types of displacement that result in compromise-formations. He distinguished "Displacement by association: hysteria.; Displacement by (conceptual) similarity: obsessional neurosis (characteristic of the place at which the defence occurs, and perhaps also of the time).; Causal displacement: paranoia" (p. 252).

In addition, in his search for a model of psychic functioning still informed by the scientific thinking and medical research of the time, Freud noted: "Hysterical repression evidently takes place with the help of symbol-formation, of displacements on to other neurones. We might think, then, that the riddle resides only in the mechanism of this displacement, and that there is nothing to be explained about repression itself" (1950c [1895], p. 352). Displacement, at work to a pathological degree in hysteria, "is thus probably a primary process, since it can easily be demonstrated in dreams" (Ibid., p. 353).

It was in fact Freud's analysis of the dream work that led him to discover the importance of displacement. He noted in *The Interpretation of Dreams* that: a) "The consequence of the displacement is that the dream-content no longer resembles the core of the dream-thoughts and . . . the dream gives no more than a distortion of the dream-wish which exists in the unconscious" (p. 308); b) Dream distortion can be "traced . . . back to the censorship which is exercised by one psychical agency in the mind over another. . . . dream-displacement comes about through the influence of the same censorship" (p. 308); and c) "[A] transference and displacement of psychical intensities occurs in the process of dream-formation" (pp. 307–308).

The notion of displacement did not see much further development. In his various revisions to his theories on dreams, Freud focused more on the



separation of images from the affects that had been attached to them, on the vicissitudes of these affects (displacement, conservation, metamorphosis), and on the fate of images (stripped of affect) in relation to the “sensory intensity of the image presented” (1900a, p. 306, n. 1). But it was above all in the process of refining the analysis of the transference during treatment and its different manifestations—lateral, indirect, and direct transference (Freud, 1915a; Sandór Ferenczi, 1909/1994; Michel Neyraut, 1974)—that the notion of displacement was expanded. It was further explored, too, by such authors as Jacques Lacan (1957/2002; 1958/2002) and Guy Rosolato (1969) who took as their starting point the work of linguists (Ullmann, 1952; Jakobson and Halle, 1956) on the relationship between signifier and signified, and on metonymy (displacement by contiguity) and metaphor (displacement by substitution).

Displacement is often linked to substitution. Not infrequently, this link is made without an adequate distinction being drawn in temporal terms between substitution where there is an immediate exchange based on the disavowal of one of the two poles involved (perceptual, hallucinatory, or conceptual substitutions), and substitution where deferred action comes into play.

ELSA SCHMIDT-KITSIKIS

*See also:* Actual neurosis/defense neurosis; Amphimixia/amphimixis; “Analysis of a Phobia in a Five-year-old Boy (little Hans)”; Cathexis; Day’s residues; Defense mechanisms; Dream symbolism; Dream work; *Ego and the Mechanisms of Defence, The*; Forgetting; Hysteria; Interpretation of dreams; *Interpretation of Dreams, The*; Jokes; Latent; Masculinity/femininity; Metonymy; Myths; Neurotic defenses; Obsessional neurosis; Overdetermination; Phobias in children; Primary process/secondary process; “Project for a Scientific Psychology, A”; Signifier/signified; “Splitting of the Ego in the Processes of Defence, The”; Substitutive formation; Symbolization, process of; Symptom-formation; Unconscious, the.

### **Bibliography**

- Ferenczi, Sándor. (1909). Introjection and transference. In *Final contribution to the problems and methods of psychoanalysis* Michael Balint (Ed.). London: Karnac Books.
- Freud, Sigmund. (1900a). The interpretation of dreams. Part 1, *SE*, 4: 1–338; Part 2, *SE*, 5: 339–625.

- . (1915a). Observations on transference love (Further recommendations on the technique of psychoanalysis III). *SE*, 12: 157–71.
- . (1950a [1887-1902]). Extracts from the Fliess papers. *SE*, 1: 173–280.
- . (1950c [1895]). Project for a scientific psychology. *SE*, 1: 295–391.
- . (1985c [1887-1904]). *The complete letters of Sigmund Freud to Wilhelm Fliess 1887–1904* (Jeffrey M. Masson, Ed. and Trans.). Cambridge, MA: Belknap/Harvard University Press.
- Jakobson, Roman, and Halle, Morris. (1956). *Fundamentals of language* (4th ed.). The Hague, New York: Mouton.
- Lacan, Jacques. (2002). The agency of the letter in the unconscious or reason since Freud. In *Écrits: A selection* (Bruce Fink, Trans.). New York: W. W. Norton. (Original work published 1957)
- . (2002). The signification of the phallus. In *Écrits: A selection* (Bruce Fink, Trans.). New York: W. W. Norton. (Original work published 1958)
- Neyraut, Michel. (1974). *Le transfert*. Paris: Presses Universitaires de France.
- Rosolato, Guy. (1969). *Essais sur le symbolique*. Paris: Gallimard.
- Ullmann, Stephen. (1952). *Précis de sémantique française*. Bern: Francke.

## **DISPLACEMENT OF THE TRANSFERENCE**

Displacement of the transference, also called lateral transference, is a defense in which transference is directed away from the analyst to a third party or an activity that both conceals and represents undesirable aspects of the transference. The idea of displacement of the transference originated in Freud’s technical writings. In “On beginning the treatment” (1913), Freud cautioned analysts about sessions that were too infrequent, which allowed the analysis to wander down side paths, and about patients who discussed their treatment with close friends every day, which would cause a “leak” in the analysis and the transference. In “Remembering, repeating, and working-through” (1914), he also said that the patient’s transference is revealed “not only in his personal attitude to his doctor but also in every other activity and relationship which may occupy his life at the time” (p. 151).

Later, other authors (for example, Daniel Lagache and Michel Neyraut) mentioned displacement of the

transference when discussing transference, usually speaking of it as resistance of a sort. Not until the work of Alain Gibeault and Evelyne Kestemberg (1981) was a positive role attributed to it. For these authors, the displacement of the transference prevents only the awareness of the transference, not the analysand's unconscious cathexis in the analysis and with the analyst. In the analysand, the external object nevertheless maintains a symbolic link with the analyst and really represents the internal-object relation resulting from the repetition of an infantile experience. These authors nevertheless recognize that the displacement of the transference, even if it is sometimes useful (notably in cases of character neurosis, where it moderates the direct confrontation with an archaic imago that is too threatening), may also interrupt the analytic process if it becomes too fixed and impervious to interpretations.

In the work of François Duparc, the displacement of the transference has been linked to analysands' difficulties in representing traumatic experiences in their histories and in connecting the affects mobilized by treatment to sufficiently elaborated representations. Thus the displacement of the transference could be considered as a less apparent aspect of negative transference, that is, of the invisible transference that Freud complains about in "Analysis terminable and interminable" (1937) in connection with his analysis of Sándor Ferenczi. Lateralization of the transference would be a primary defense and counter-cathexis of a nonrepresentable or not yet represented experience. By means of a displacement of the transference, the patient might be trying to protect the analyst from a violent discharge in the transference, which the analyst could not bear without a traumatizing counter-transferential reaction.

One can describe a range of transferences, according to their greater or lesser lateral aim: the direct transference, which in the case of traumatic material induces disturbing and strange counter-transferential experiences; transference on a model, which is more protective because the model is the inert part of the transference that limits the involvement of nonrepresentable experiences; and finally displacement of the transference, which aims at protecting both the patient and the analyst from a traumatic outbreak.

FRANÇOIS DUPARC

*See also:* Counter-transference; Negative therapeutic reaction; Transference.

### Bibliography

- Duparc, François. (1988). Transfert latéral, transfert du négatif. *Revue française de psychanalyse*, 52 (4), 887–898.
- Freud, Sigmund. (1913). On beginning the treatment (further recommendations on technique of psycho-analysis I). *SE*, 12: 121–144.
- . (1914). Remembering, repeating, and working-through (further recommendations on the technique of psycho-analysis II). *SE*, 12: 145–156.
- . (1937). Analysis terminable and interminable. *SE*, 23: 209–253.
- Gibeault, Alain, and Kestemberg, Evelyne. (1981). Le personnage tiers. *Cahiers du Centre pour la psychanalyse et la psychothérapie*, 3, 1–84.

---

### DISQUE VERT, LE

In 1924 *Le Disque vert*, a Belgian review founded and directed by the poet and writer Frédéric Van Ermenegen, known as Franz Hellens (1881–1972), published a special issue devoted to "Freud et la psychanalyse," confirming Sigmund Freud's belief that "interest in psychoanalysis has spread to writers in France." (1925d) It is significant that at this time very few of Freud's writings were accessible in French.

A message from Freud, dated February 26, 1924, introduced the issue: "Of the many lessons lavished upon me in the past (1885–1886) by the great Charcot at the Salpêtrière [1885–1888], two left me with a deep impression: that one should never tire of considering the same phenomena again and again (or of submitting to their effects), and that one should not mind meeting with contradiction on every side provided one has worked sincerely."

There were approximately forty-five contributors to the special issue, all with different opinions, positive and negative, about psychoanalysis, providing an important overview of the attitudes toward psychoanalysis in France. Among the contributors were writers (M. Arland, R. Fernandez, V. Larbaud, H. R. Lenormand, J. Rivière, Philippe Soupault, René Crevel, Henri Michaux), psychoanalysts (Angélo Hesnard, René Laforgue, René Allendy), psychiatrists and psychologists (E. Claparède, L. Lapicque, Y. Le Lay).

According to Edmond Jaloux, many writers were hostile to Freud's theories because "they saw in them an attack on the classical conception of human

personality.” For Jacques de Lacretelle, although some subscribed to the new field, many could not, “because its ideas take place in a field that is almost new to them, one they are only beginning to make use of: the unconscious.”

Louis Lapicque, who then held the chair of general psychology at the Sorbonne, had no hesitations: “I have to admit that the ideas of the Viennese professor, although they were sufficiently amusing for me to acquaint myself with them superficially, did not seem to be scientific material and I do not feel capable of discussing them seriously.” Étienne Rabaud, professor of biology at the Sorbonne, had a similar opinion: “Within being unaware of Freudianism, I haven’t taken the time to make a serious study of it; my limited examination has not left me with a desire to continue.” Georges Dwelshauvers, director of the laboratory of experimental psychology in Catalonia, suspected fraud: “He has been inspired by the clinics of Charcot and his school, and the work, so rich in written material, of doctors Raymond and Pierre Janet. He is their student and continues their tradition. And do we know who the real author of psychoanalysis was? It was J. Delboeuf, the psychologist from Liege.”

The partisans remained undecided. Professor Henri Claude, head physician at the Clinique des Maladies Mentales at the Sainte-Anne Hospital, the first and only hospital that employed psychoanalysts, wrote, “It is mostly psychologists and writers who have been discussing Freud’s work and that of his followers, faithful or dissident, and who, leaving the primitive framework of medicine, have decided to criticize the extension of the doctrine, especially the theory of pansexual symbolism, to all manifestations of intellectual activity. In place of these glosses, we would have preferred reliable personal research, free of prejudice, imbued with the spirit of scientific observation.” He added, and René Allendy was in agreement, “I feel, like Adler and Stekel, that we should not lead those unfamiliar with psychoanalysis to believe that Freudian pansexualism is all there is to the field.” “Pansexualism” and “symbolism” were signs of Freudianism’s disgrace, even though, as Edmond Jaloux so reassuringly remarked, “there are few repressed individuals in France.”

Angélo Hesnard indicated the prevailing pessimism of the time: “Current French opinion about Freud remains inconclusive ... It will never be

favorable to him for, whatever he may think—and in spite of his work with Charcot—the Master of Vienna has remained, in his work, quite remote from French attitudes. And in the extreme and naïve way it confuses facts and theory, doctrine and method, psychoanalysis will never convince anyone except those who have the courage and scientific probity to experiment with it themselves and adapt it to the French mind.”

Along with Édouard Claparède, Albert Thibaudet, a writer, who had already written a positive article in April 1921 in the *Nouvelle Revue française*, was more optimistic. He wrote, “I only want to say that I see Freud as a man who has entered a long corridor, filled with disorder, with poorly catalogued, poorly lit, poorly interpreted objects, but which holds treasures for the museums of the future and for the literature of today.”

André Gide, on June 19, 1924, wrote, after closing the copy of *Le Disque vert* he had been reading in the train that carried him to Cuverville, “Oh, how annoying Freud is; it seems to me that we managed quite well without him in discovering his America! ... What he adds, most of all, is his audacity, or, more exactly, he relieves us of a certain false and tiresome modesty. But there is so much that is absurd in this imbecile of genius!”

ALAIN DE MIJOLLA

### Source Citation

*Le Disque vert* (1924). Freud et la psychanalyse, 2nd year, June 1924.

### Bibliography

Gide, André. (1953). *The Journals of André Gide*. (Justin O’Brien, Trans.) New York: Knopf.

Mijolla, Alain de. (1984). Quelques avatars de la psychanalyse en France. Lecture du *Disque Vert* (June 1924). *L’Évolution psychiatrique*, 49, 3, 773–795.

---

**DISTRESS.** See *Helplessness*

---

## “DISTURBANCE OF MEMORY ON THE ACROPOLIS, A”

Sigmund Freud had begun corresponding with Romain Rolland in 1923, and this open letter is the

acme (and indeed the end) of their exchange. In it, Freud relates a personal experience dating from his first visit to Athens, in 1904. He had climbed the Acropolis in company with his brother Alexander, who was ten years his younger—the same age, in fact, as Rolland—and in front of the Parthenon he was overtaken by a feeling of strangeness, of a sense that “this is too good to be true.”

In 1904 Freud was bringing his relationship with Wilhelm Fliess to a close in an atmosphere of conflict. A transference to Fliess had provided him with the support needed for his original self-analysis, and it was not until 1936, relying now on a transference to Rolland, that he was able to analyze this episode. The few pages of the letter here under consideration are a self-analytical summary of an entire lifetime, and they retrace the path followed by Freud’s whole work, with two Frenchmen standing for the beginning and end points respectively: at the beginning, Charcot (suggested by Freud’s use of several French psychiatric terms of the period); and, at the end, Romain Rolland.

The letter resembles an analytic session, with Freud addressing an alter ego to whom he seems to have lent his pen, thus handing off the role of analyst (Kanzer, Mark, 1969). Oedipal themes are in evidence: guilt about having surpassed the father and conquered the mother (Athens, after Paris and Rome) by producing a work of whose value Freud was well aware. The feeling of strangeness (or “derealization”) might stem from the emergence of unconscious material (or “sensations”) split off as a result of the trauma experienced by Freud at the age of two, when his young brother Julius died. Here Freud’s letter mirrors Rolland’s evocation—in his *Voyage Within*, which he began writing right after his visit to Freud in 1924—of the death of his sister Madeleine when he was five, and the long mourning of his mother that followed. Freud’s letter is also a response (itself deferred) to his French friend concerning the inner reality of that oceanic feeling whose existence in himself Freud had at first denied (in *Civilization and Its Discontents* [1930a], p. 65); here he stresses the feeling’s traumatic aspect—perceived only when there is no longer a split between the two levels of mental functioning involved.

Feelings of strangeness also arise from the gulf separating Freud’s integration into German culture (the Acropolis being associated with the cult of antiquity of the Goethe years) and the *sotto voce* reference to the destroyed temple in Jerusalem, a foundation of

Freud’s Jewishness; the first title given this letter, namely “Unglaube [disbelief or incredulity] auf der Akropolis,” is certainly evocative of Freud’s identity as an atheist Jew, and suggests a kind of Spinozist collusion with his churchless Christian correspondent.

But if the hallowed nature of the site (see Freud, 1927c) harks back to religion—the chief topic of the Freud-Rolland correspondence—in a more secular sense it summons up the origins of sublimation as a latent theme of the dialogue between these two great creators. The *Erlebnis*, Freud’s experience of the Acropolis, bespoke the rush of emotion that assailed him on this high place as his life’s work was just getting under way; by 1936 Freud could look back in tranquility on the road behind him.

To his correspondent, likewise well on in years and nearing the end, Freud sends a message that is also a meditation on death—and on immortality. Embedded within it is the fantasy that he might climb up to the Acropolis accompanied by a winner of the Nobel Prize—a distinction which Freud, discreetly, had not abandoned hope of attaining himself. The resolution of Freud’s transference to Romain Rolland would free up a vital energy sufficient to inspire a cluster of last writings developing many of the themes touched upon in this open letter.

HENRI VERMOREL

*See also:* Déjà-vu; Depersonalization; Disavowal; Freud, Jakob Kolloman (or Kelemen or Kallamon); Freud, Sigmund (siblings); Illusion; Memory; Oceanic feeling; Rolland, Romain Edme Paul-Émile; “Uncanny, The.”

### Source Citation

Freud, Sigmund. (1936a). Brief an Romain Rolland: Eine Erinnerungsstörung auf der Akropolis. In *Almanach der Psychoanalyse 1937*, Vienna: Internationaler Psychoanalytischer Verlag, pp. 9–21; *GW*, 16, 250–57; A disturbance of memory on the Acropolis: An open letter to Romain Rolland on the occasion of his seventieth birthday. *SE*, 22: 239–48.

### Bibliography

- Freud, Sigmund. (1927c). The future of an illusion. *SE*, 21, 1–56.
- . (1930a). Civilization and its discontents. *SE*, 21, 57–145.
- Kanzer, Mark. (1969). Sigmund and Alexander Freud on the Acropolis. *American Imago*, 26, 324–54.

Parat, Catherine. (1988). *Dynamique du sacré*. Lyon: Cesura.

Vermorel, Henri and Vermorel, Madeleine. (1993). *Sigmund Freud et Romain Rolland. Correspondance 1923–1936*. (Alain de Mijolla, Ed.). Paris: Presses Universitaires de France.

---

## DOCUMENTS ET DÉBATS

The Association psychanalytique de France (APF), or French Psychoanalytic Association, has, since it was formed in 1964, published a *Bulletin intérieur*; this name was retained until 1970, when it became *Documents et Débats* (Documents and Debates). Originally its purpose was to publish reports of internal discussions and the annual general meeting. Editorial responsibilities initially belonged to a committee presided over by Jean Laplanche, who entrusted Jean-Louis Lang, vice president, with the role of editor.

Looking through past issues of the review provides an illuminating survey of the world of publishing; the quality of the paper, print, and typography make for pleasant reading. The cover design has changed over the years—from Bordeaux red to dark green, from carmine red to light gray, the color of the present volume, which is devoted to *Gradiva*. In 1991, with Raoul Moury as president, *Documents et Débats* underwent its latest design overhaul.

Organization of the magazine is unique. The editor changes whenever a new board is elected. The editor accepts but does not suggest material for publication. Distribution is restricted exclusively to members and analysts undergoing training. The review serves a unifying role in a profession that tends to isolate analysts: the text is edited in Lyon and printed in Paris; editors have come from Bordeaux, Lyon, Nantes, and Paris.

Issues appear on a regular basis and mark the progress of the association. Every year an issue is devoted to the publication of official documents, reports of the annual meeting, national and international reunions at which association members have participated ex officio. A second issue publishes the texts of papers given throughout the year as part of the biannual meetings and scientific get-togethers.

There have also been special issues devoted to the work of individual colleagues at the time of their death. There have been homages to Daniel Lagache (1975), Angelo Bejarano (1981), Georges Favez (1982), and Victor Smirnoff (1995). Occasionally,

special issues have been proposed on particular topics—“La psychanalyse en société” (Psychoanalysis in Society) (1985), “APF and IPA” (1987), “A.P.F. au passé-présent” (The A.P.F. in the Past and in the Present) (1988), “La formation” (Training) (1990)—introducing discussion within the association. However, in spite of the number of requests, it appears that this method of exchange is not necessarily the most appropriate or the most popular.

Psychoanalysts in the APF have often helped found psychoanalytic journals. The list of their editorial contributions is long and includes *Nouvelle Revue de psychanalyse* (New Review of Psychoanalysis), *Psychanalyse à l’université* (Psychoanalysis in the University), *L’Écrit du temps* (The Writing of Time), *La Revue internationale de psychopathologie* (International Review of Psychopathology), *L’Inactuel*, *Le Journal de la psychanalyse de l’enfant* (The Journal of Child Psychoanalysis), *Le Fait de l’analyse* (The Fact of Analysis), and *Libres Cahiers pour la psychanalyse* (Psychoanalytic Notebooks). These publications have created forms of discussion and research outside the APF that have strengthened the identity of *Documents et Débats*.

The bulletin remains the vehicle for disseminating information about the association and promotes the circulation of texts among members to solicit and support scientific research. In this way *Documents et Débats* contributes to maintaining a serious dialogue that any association worthy of the name must have.

JEAN-YVES TAMET

See also: Association psychanalytique de France.

---

## DOLTO-MARETTE, FRANÇOISE (1908–1988)

Françoise Dolto-Marette, a French psychoanalyst, was born in Paris on November 6, 1908, and she died there on August 28, 1988. Dolto’s *Enfances* (Childhoods; 1986) and *Autoportrait d’une psychanalyste* (Self-portrait of a woman psychoanalyst; 1989) tell the story of how a little girl born into a middle-class family at the turn of the twentieth century became a doctor and psychoanalyst. The two books recount the traumatic loss of a beloved nanny when she was a few months old; the death at the front on July 10, 1916, of her

uncle Pierre, who was her godfather and whom she thought of as her “fiancé”; and the death of her older sister, Jacqueline, when she was eleven. At her first communion, her mother asked her to pray to save her sister, who contracted bone cancer at the age of eighteen. “I would never have become a psychoanalyst,” she wrote, “were it not for this grief that upset the whole family. I think I would have become a doctor in any case, because I had wanted to since I was eight, but I would not have become an analyst if my sister had not died and if I had not experienced my mother’s pathological mourning, my father’s suffering and bewilderment, and the pain of my brother Pierre, the oldest of the boys.” René Laforgue, her analyst, noted a “family neurosis” extending across the generations in her family. Part of this family neurosis was a “myth of the savior”: Dolto’s paternal grandfather died while rescuing five women in a railway fire, and her maternal grandfather, a prisoner in 1870, was “saved by his sister disguised as a peasant girl.”

Dolto began her analysis with Laforgue in 1931, and he subsequently encouraged her to get involved in child analysis, at which she was very gifted, according to Sophie Morgenstern. Her supervisors were Heinz Hartmann, Angel Garma, Rudolph Löwenstein, René Spitz, John Leuba, and Morgenstern. She was elected to membership in the Société psychanalytique de Paris (Paris Psychoanalytic Society) on June 20, 1939, about the time of the publication of her thesis in medicine, *Psychoanalyse et pédiatrie* (Psychoanalysis and pediatrics; 1971b).

At the Hôpital Trousseau, Dolto worked for a short time in Jenny Aubry’s pediatric ward. Then after Édouard Pichon’s death, she took over and ran his consultancy from 1940 to 1978. She ran the consultancy in innovative ways and independently of the psychiatry ward, and she opened it to analysts wishing to train in child analysis. Numerous participants can attest to the quality of her input and to what they learned by watching her work with children and their parents. She was the first analyst to modify the therapeutic setting by bringing in “witnesses” who rarely contributed, one of them taking notes and the others playing a role analogous to that of a Greek chorus. Here she began accepting infant patients, which was most unusual at the time. At offices in Paris she engaged in the same sort of practice with children from the Antony nursery and state foster homes.

In tandem with these activities, she started a Tuesday-evening study seminar on children’s drawings and, on two Thursdays per month, a seminar in child analysis for psychoanalysts and therapists. She led the seminar for nearly fifteen years. During its last years, the seminar brought together as many as several hundred participants.

At the time of the first split in the French psychoanalytic movement, Dolto—along with Jacques Lacan, Daniel Lagache, and Juliette Favez-Boutonier—founded the Société française de psychanalyse (French Society of Psychoanalysis) in 1953. For the 1960 congress on female sexuality in Amsterdam, she wrote “La libido génitale et son destin féminin” (Genital libido and its vicissitudes in women; 1996b). From 1947 she published numerous articles in the socialist journal *La revue de l’union des femmes françaises*, and later in *Les études carmélitaines*, *Psyché*, and the journal of the École des parents (Parents’ school). She worked at the Centre Étienne-Marcel from its inception and published in *Le coq-héron*, and in 1971 published *Dominique: the analysis of an adolescent*, a case history of the treatment of a “retarded” patient.

In 1964 she was a follower of Jacques Lacan during the creation of the École freudienne de Paris. At that time the International Psychoanalytical Association excommunicated the Lacanians, forbidding them to teach and train analysts. On August 2, 1962, Serge Lebovici, addressing the executive committee of the International Psychoanalytical Association in Edinburgh, demanded that they separate “the wheat from the chaff” and accused Dolto of being what she was, neither a Kleinian nor a follower of Anna Freud. In Dolto’s case, the reasons for the excommunication still have not been clearly explained. One can only conclude that a great injustice was committed.

Her radio programs, beginning in 1976 and listened to by parents all over France, established her as an analyst in touch with society and actively engaged in the cause of children. The list of her contributions is extensive: her work with the deaf, her active support of the Neuville schools, her long preface to Maud Mannoni’s book, *Le Premier rendez-vous avec le psychanalyste*, her decisive influence in the training of educators and childcare workers, her contributions in support of children’s rights. She also actively participated in numerous colloquia and meetings: *Naître et ensuite* (Birth and Afterwards), within the framework of the Groupe de recherche et d’étude du nouveau-né

(Group for the Research and Study of Newborns), and the Bordeaux conference *Enfants et souffrance* (Children and suffering). These many innovative experiments have given her an original and incontrovertible place in the history of relations between psychoanalysis and society. Her concepts of the “unconscious body image,” female libido, and “symbolic castration,” debated by the psychoanalytic community, were, for her students, “valuable tools that were indispensable in the clinical treatment of very young children or patients in great distress.” They were the fruit of a life devoted to “hearing” the needs of infants when they are still incapable of speech but can express themselves in their own ways.

The creation of a welcome facility for little ones accompanied by their parents (founded in January 1978), later the *Maison verte de Paris* (which opened in January 1979), attests to the efforts of Dolto and her collaborators at the Centre Étienne-Marcel—Pierre Benoît, Colette Langignon, and Bernard This—to promote, together with Marie-Noëlle Rebois, Marie-Hélène Malandrin, Nelba Nasio, Claude This, and all those who came later, the prevention of early childhood emotional disturbances. This innovation by a group of analysts and educators, recognized by the Fondation de France (Foundation of France), led to many other welcome facilities in France and other countries.

A three-volume collection of Dolto’s radio programs, *Lorsque l’enfant paraît* (When the child appears; 1990), first appeared in 1977, 1978, and 1979. Her other publications include *The Jesus of psychoanalysis: a Freudian interpretation of the Gospel* (1979); in 1981, *La difficulté de vivre* (The difficulty of living; 1995), *Au jeu du désir* (The play of desire), and *Les évangiles et la foi au risque de la psychanalyse* (The Gospel and faith in the light of psychoanalysis; 1996a); in 1982, *Séminaire de psychanalyse d’enfants* (Seminar on child analysis); in 1984, *L’image inconsciente du corps* (The unconscious body image); in 1985, *La cause des enfants* (The cause of children) and *Solitude* (1987b); in 1987, *Tout est langage* (Everything is language; 2002), *L’enfant du miroir* (The child of the mirror), and *Dialogues québécois* (Quebec dialogues); and in 1992, *Inconscient et destin* (The unconscious and fate) and *Quand les parents se séparent* (When parents separate). Many aspects of Dolto’s career show that this clinician and internationally renowned psychoanalyst sought to make her ideas accessible to all. After her death on August 25, 1988,

many of her contributions were published, and the Association archives et documentation Françoise Dolto was established in Paris in 1990.

BERNARD THIS

*Works discussed:* *Flower Doll: Essays in Child Psychotherapy*; *Psychanalyse et Pédiatrie* (psychoanalysis and pediatrics).

*See also:* Armand Trousseau Children’s Hospital; Child psychoanalysis; École freudienne de Paris; France; *Psychanalyse, La*; Puberty; Société française de psychanalyse; Technique with children, psychoanalytic.

### Bibliography

- Dolto, Françoise. (1971a). *Dominique: the analysis of an adolescent*. New York: Outerbridge and Lazard.
- . (1971b). *Psychanalyse et pédiatrie*. Paris: Seuil. (Originally published 1939)
- . (1981). *Au jeu du désir: essais clinique*. Paris: Seuil.
- . (1982). *Séminaire de psychanalyse d’enfants*. Paris: Seuil.
- . (1984). *L’image inconsciente du corps*. Paris: Seuil.
- . (1985). *La cause des enfants*. Paris: R. Laffont.
- . (1986). *Enfances*. Paris: Seuil.
- . (1987a). *Dialogues québécois*. Paris: Editions du Seuil.
- . (1987b). *Solitude*. Paris: Vertiges du Nord.
- . (1989). *Autoportrait d’une psychanalyste*. Paris: Seuil.
- . (1990). *Lorsque l’enfant paraît*. Paris: Seuil. (Originally published 1977–1979)
- . (1992). *Inconscient et destins*. Paris: Seuil.
- . (1995). *La difficulté de vivre*. Paris: Gallimard. (Originally published 1981)
- . (1996a). *Les évangiles et la foi au risque de la psychanalyse*. Paris: Gallimard.
- . (1996b). La libido génitale et son destin féminin. In her *Sexualité féminine. La libido génitale et son destin féminin*. Paris: Gallimard. (Originally published 1964)
- Dolto, Françoise, and Angelino, Inès. (1988). *Quand les parents se séparent*. Paris: Seuil.
- Dolto, Françoise; Baldy Moulinier, Claude; Guillerault, Gérard; and Kouki, Elisabeth. (2002). *Tout est langage*. Paris: Gallimard. (Originally published 1987)

Dolto, Françoise, and Nasio, Juan-David. (1987). *L'enfant du miroir*. Paris: Rivages.

Dolto, Françoise, and Séverin, Gérard. (1979). *The Jesus of psychoanalysis: a Freudian interpretation of the Gospel*. (Helen R. Lane, Trans.) Garden City, NY: Doubleday. (Original work published 1977)

---

## DON JUAN AND THE DOUBLE

In 1914 and 1922, Otto Rank published two essays in German in *Imago: The Double* and *Don Juan*. Rank was inspired to write *The Double* after seeing a film by H. H. Ewer, *The Student of Prague*, and a presentation of Mozart's Don Giovanni led him to write *Don Juan*. As the author himself noted, "In both texts, there is a question of problems going back to the most remote origins of mankind, which continue to have a profound influence on art." These problems are "the relationship between individuals and their own ego and the threat of its complete destruction by death."

Rank was a particularly prolific writer with an extensive knowledge of literature and anthropology, as shown by these two essays and alluded to in his belief that "the creative artist is, from the psychological point of view, the extension of the hero of prehistoric humanity." In *The Double* he explores the theme of the double in literature as a kind of shadow, reflection, portrait, twin, or even duplication of mental life resulting from amnesia or manipulation (as in Robert Louis Stevenson's *Dr. Jekyll and Mr. Hyde*). Rank examines various possibilities, including the terrible consequences if the shadow is lost and the independent double persecutes the ego.

Sigmund Freud in his essay "The Uncanny" (1919h) noted that Rank had succeeded in explaining the surprising evolution of the theme of the double. "For the 'double' was originally an insurance against the destruction of the ego, an 'energetic denial of the power of death,' " but, Freud adds, "such ideas have sprung from the soil of unbounded self-love, from the primary narcissism which dominates the mind of the child and of primitive man. But when this stage has been surmounted, the 'double' reverses its aspect. From having been an assurance of immortality, it becomes the uncanny [unheimlich] harbinger of death" (1919h, p. 235).

Referring to the myth of Narcissus and to the narcissistic hero Dorian Gray in Oscar Wilde's *The Picture*

of *Dorian Gray*, Rank notes that the hero's misfortune follows from his disposition to narcissism, which turns him into the prisoner of his double. The double then becomes a rival in sexual love or appears in superstitious belief as a terrifying messenger of death, a devil, or an anti-ego, destroying rather than replacing the ego.

The essay on Don Juan (1922/1975) is also related to the theme of the double. Rank asserts that it is impossible to consider the legend of Don Juan solely in Freud's sense and explain it by the father complex (p. 86). Rank shows that the division of the personality into the master Don Juan and the valet Leporello is a "necessary part of the artistic presentation of the hero himself" (p. 50), for "[b]y inhibiting the will of his master, whose thirst for action he continually keeps in check with uncanny irony, he is characterized as the critical-ironic part of the ego" (p. 59). Starting from the idea of "avenging death" Rank also develops interesting perspectives on cannibalism.

SOPHIE DE MIJOLLA-MELLOR

See also: Double, the; Rank (Rosenfeld), Otto; "'Uncanny,' The."

### Source Citation

Rank, Otto. (1971). *The double: a psychoanalytic study* (Harry Tucker Jr., Trans.). Chapel Hill: University of North Carolina Press. (Original work published 1914)

Rank, Otto. (1975). *The Don Juan legend* (David G. Winter, Trans.). Princeton: Princeton University Press. (Original work published 1922)

### Bibliography

Freud, Sigmund. (1919h). The uncanny. *SE*, 17: 217–256.

Lieberman, E. James. (1985). *Acts of will: the life and work of Otto Rank*. New York: Free Press.

---

## DOOLITTLE-ALDINGTON, HILDA (H.D.), (1886–1961)

The American poet Hilda Doolittle was born on September 10, 1886, in Bethlehem, Pennsylvania, and died in Zurich in September 1961. From her analysis with Freud during 1933–1934 she left a diary, a written homage to Freud: *Tribute to Freud*, (1944), which represents a precious account of their warm and positive analytic relationship.



The only daughter of four children, her father was Charles Leander Doolittle, a professor of astronomy who, in 1897, began teaching at the University of Pennsylvania. There Hilda discovered her calling as a poet, encouraged by her relationship with Ezra Pound, who at age 20, just a year older than she, had just been appointed instructor. Although her father forbade her to carry on a relationship with Pound, who would soon be expelled for immorality, Hilda kept up a correspondence with him that in 1911 brought her to Europe, where she would spend the rest of her life. She went initially to England with Frances Gregg, with whom she had a homosexual liaison, and soon met Richard Aldington, a poet six years younger than herself.

H.D. published her first poems in 1913, and married Aldington the same year. The couple lost their first daughter in 1915, but a second daughter, named Perdita in memory of the first, was born on March 31, 1919. Hilda's favorite brother, Gilbert, was killed in France in 1918, and her father, seriously affected by the news, died a year later. In 1919, H.D.'s marriage ended, as did her brief but intense friendship with D. H. Lawrence.

When H.D. had suffered post-partum depression after the birth of her daughter, she owed her recovery to Bryher (Winifred Ellerman), an energetic novelist and poet who became her companion and took her and Perdita to live in Greece. While living in Corfu, H.D. suffered an episode of depersonalization, an experience that held no particular interest for Havelock Ellis, who was in some measure attracted to her. She also had a hallucinatory vision of "writing on the wall" that Freud characterized as a "dangerous symptom" when she told him about it. This vision may explain the mild and tender positive countertransference behavior that Freud adopted toward her.

Bryher, who had been analyzed by Hanns Sachs, acquainted H.D. with psychoanalysis. An initial effort at analysis with Mary Chadwick in the spring in 1931 was a failure, but it led H.D. to begin treatment in Berlin with Sachs, who subsequently introduced her to Freud. By then well-known for her imagist verse, H.D. sought analysis to remedy a sense of sterility in her writing.

Freud had read some of her work, including *Palimpseste*, before their first meeting on Wednesday, March 1, 1933. In the diary she kept of her analysis (in

spite of his disapproval—he viewed it as resistance), she described him as "like a curator in a museum . . . ; he is like D. H. Lawrence, grown old but matured and with astute perception. His hands are sensitive and frail" (1974, p. 116). From the beginning of treatment Freud brought her to see his collection of antiquities and showed her a small statue of Athena: "This is my favorite," he remarked (p. 118). "You are the only person to have ever entered this room and looked at the objects before looking at me."

This first session set the tone of an analysis in which Freud quickly interpreted that "not only did I want to be a boy but I wanted to be a hero" (p. 120). His interventions made him into "the grandfather godfather, god-the-father" (p. 120). He told her at one point, "I was thinking about what you said, about its not being worthwhile to love an old man of seventy-seven," and H.D. wrote, "I had said no such thing and told him so. He smiled his ironical crooked smile. I said, 'I did not say it was not worthwhile. I said I was afraid.' But he confused me. He said, 'In analysis, the person is dead after the analysis is over—as dead as your father'" (p. 141).

Freud also confided in her that "I do not like being the mother in transference—it always surprises and shocks me a little. I feel so very masculine" (pp. 146–147). H.D.'s mother had traveled with her and Aldington when they were lovers, and later lived with her in Europe for long periods in the 1920s before her death in 1927; Freud viewed her as the root cause of H.D.'s confusion and homosexuality.

After three months of analysis, H.D. left Vienna on June 15, 1933. When she returned at the end of October, to remain until December 1, she was concerned about the rise of Nazism; she immediately perceived the danger that it posed for "the Professor." Once again, describing in unparalleled fashion during the next five weeks of exceptional sessions, she sketched a poetical and moving portrait. She did so without concessions; attracted by the strange and bizarre, by astrology and belief in paranormal phenomena, she sometimes confronted the convictions of an old man. For his part, Freud hoped to introduce into her mental universe the father figure and finally succeeded. "We have gone into deep matters," he told her after one session (p. 177); after another, he said, "Today we have tunneled very deep." (p. 18).

H.D. had further sessions in 1936 and 1937, rather more as psychotherapy, with Walter Schmideberg.

Until his death she never failed to send Freud gardenias for his birthday. In 1944 she wrote her memoir, first entitled *Writing on the Wall*, which appeared in 1956 as *Tribute to the World*. Soon after World War II, H.D. turned toward spirituality and underwent a severe mental breakdown and deep depression.

Moving to Switzerland in the late 1940s, H.D. enjoyed a productive and successful career in the last years of her life, publishing several books of poems, memoirs, and short stories that brought her considerable attention in literary circles in the United States. A hip fracture in 1960 left her handicapped until her death on September 27, 1961.

ALAIN DE MIJOLLA

See also: Literature and psychoanalysis.

### Bibliography

- Appignanesi, Lisa, Forrester, John. (1992). *Freud's women*. London: Weidenfeld and Nicolson.
- Doolittle, Hilda. (1974). *Tribute to Freud*. Boston: David R. Godine.
- Holland, Norman N. (1973). “Freud and H.D.” *International Journal of Psycho-Analysis*, 50, 309–315. Reprinted in *Freud as we knew him*. (pp. 449–462). (Hendrik M. Ruitenbeek, Ed.). Detroit: Wayne State University Press.
- Friedman, Susan Stanford. (2002). *Analysing Freud: letters of HD, Bryher and their circle*. New York: New Directions.

---

**DORA.** See “Fragment of an Analysis of a Case of Hysteria” (Dora/Ida Bauer)

---

## “DOSTOYEVSKY AND PARRICIDE”

Freud distinguished Dostoyevsky the writer, Dostoyevsky the neurotic, Dostoyevsky the moralist, and Dostoyevsky the sinner. Freud regarded Dostoyevsky the writer as unassailable, placing his work alongside Sophocles’ *Oedipus Rex* and Shakespeare’s *Hamlet*. The moralist Freud dismissed, for Dostoyevsky confined himself to being the sinner, subject to the czar and God, even while he oscillated between faith

and atheism. Sadistic toward the outside world where small things were concerned, and toward himself where large things were concerned, Dostoyevsky finally appeared to be a masochist, “that is to say the mildest, kindest, most helpful person possible” (p. 179). But for Freud there is more: Dostoyevsky’s projections into his characters—violent, egocentric, criminal—bear witness to his identification with them. The sexual attack on the young girl as related to Strakov, would support this view, as would Dostoyevsky’s passion for gambling.

Dostoyevsky’s impulsive character interfered with his neurosis, and as a result, his ego lost its unity, a condition that expressed itself in his so-called epilepsy. This condition was, however, no more than a symptom of his neurosis, hystero-epilepsy, a serious form of hysteria. Freud pointed out the memory difficulties associated with such epilepsy and the limited understanding of the disease at the time. Dostoyevsky’s affliction appears to have been a case of the ancient *morbus sacer* (sacred illness) or a clinical variant. Its link with psychic life does not interfere with “complete mental development and, if anything, an excessive and as a rule insufficiently controlled emotional life” (p. 180), characteristic of Dostoyevsky’s mental functioning. The mechanism of his abnormal instinctual discharge, organically preconditioned, was made available to his neurosis, and through somatic means, it eliminated any excitation not psychically contained.

For Freud, Dostoyevsky’s first, slight attacks harked back to childhood and did not assume a true epileptic form until after the traumatic event of the murder of his father by Russian peasants. Psychoanalysis showed that this was the keystone of Dostoyevsky’s neurosis, and the parricide of the Karamazovs reflects this. Dostoyevsky’s anxieties about death, which he experienced in his youth, together with his states of lethargic sleep, would indicate that Dostoyevsky identified with the dead or with someone whose death he desired, and may have triggered a mechanism of self-punishment.

Freud then returns to his hypothesis about the murder of the father in the primitive horde, humanity’s primal crime, which is reproduced in fantasy in every individual: the little boy, in his ambivalent relationship to his father (fear of castration or tenderness), must renounce his desire to possess the mother and eliminate the father, but a sense of unconscious guilt

remains. In Dostoyevsky, a strong bisexual disposition conditioned and reinforced his neurosis, intensifying his defense against a “remarkably harsh” father. Thus the relationship between Dostoyevsky and the paternal object was transformed into a relationship between the ego and the superego. Once the murder of his father had given a sense of reality to such repressed desires, epilepsy followed.

The atmosphere indicates the liberation experienced, whereas the punitive dimension is confirmed in jail, where Dostoyevsky’s crises do not disappear but at least no longer weaken him, in spite of the injustice of the punishment: the czar has replaced the father. Dostoyevsky took this one step farther: the epileptic is the parricide—the culmination of his identification with common, political, and religious criminals—but the gambling debt, satisfying the need for self-punishment, enables him to write and succeed as a novelist.

Curiously, at the end of this article on Dostoyevsky, Freud also analyzed Stefan Zweig’s short story “Twenty-four Hours in the Life of a Woman.” Freud sees this short story as the fantasy of a young man (also a gambler), in which his mother initiates him into sexual life to protect him from masturbation, a compulsion Freud assumed to be present in Dostoyevsky.

Freud spent two years (1926–1928) reluctantly writing this article on “the cursed Russian,” whom he claimed not to have liked. His work led to discussions with Theodor Reik and Stefan Zweig. The article did not cause much of a stir when it was published, and the question of epilepsy failed to generate interest. Freud’s ambivalence toward the writer’s “pathological nature” attests to a certain rivalry with Dostoyevsky over the latter’s exploration of the unconscious, but may also indicate Freud’s parricidal wishes toward Jean Martin Charcot, the father of hystero-epilepsy, wishes quite different from Dostoyevsky’s epilepsy. Freud’s interpretation of the onset of Dostoyevsky’s crisis remains questionable, as does his interpretation of the father’s “murder.” At the time (1928), Dostoyevsky’s past was still largely unknown.

MARIE-THÉRÈSE NEYRAUT-SUTTERMAN

*See also:* Self-punishment; “Creative Writers and Day-Dreaming”; Literary and artistic creation; Parricide; Zweig, Stefan.

### Source Citation

Freud, Sigmund. (1928b). Dostoyevsky and parricide. *SE*, 21, 173–196.

### Bibliography

- Drouilly, Jean. (1977). Freud et Dostoïewski. *Évolution psychiatrique*, 42, 1, 127–140.
- Green, André. (1992). Le double double: Ceci et cela. In his *La déliaison: Psychanalyse, anthropologie et littérature* (pp. 299–311). Paris: Belles Lettres.
- Marinov, Vladimir. (1990). *Figures du crime chez Dostoïewski*. Paris: Presses Universitaires de France.
- Neyraut-Sutterman, Marie-Thérèse. (1970). Parricide et épilepsie: À propos d’un article de Freud sur Dostoïewski. *Revue Française de Psychanalyse*, 34, 4, 635–652.
- Tellenbach, Hubertus. (1976). Phénoménologie de l’intrication entre épilepsie et changement de la personnalité à l’exemple du prince Myichkine de Dostoïewski. *Psychanalyse à l’Université*, 1, 2, 341–354.

---

## DOSUZKOV, THEODOR (1899–1982)

Theodor Dosuzkov, a physician and practicing psychoanalyst, was born on January 25, 1899, in Baku, then Russia, and died in Prague, Czechoslovakia, on January 19, 1982. He was the only child of a jurist aristocrat father and a Jewish mother.

The October 1917 revolution surprised the family in Saint Petersburg. They fled before the Red Army and finally arrived at Novorossiisk in 1919. There Theodor Dosuzkov took his baccalaureate and met his future wife, with whom he left the country in 1920 bound for Prague via Constantinople. The Prague government was offering grants to Russian students. He studied medicine from 1921 to 1927 and then worked in the university neurology clinic, specializing in neurology and psychiatry.

Through a circle of Russian intellectuals he met Nicolai Ossipov, who awakened his lifelong interest in psychoanalysis. When Ossipov died in 1934, Dosuzkov inherited his library and his correspondence with Freud. Internal intrigues prevented Dosuzkov from winning a university appointment. Disappointed, he left the university clinic and opened his own clinic in 1934 and practiced as a neurologist and psychoanalyst. He finished his psychoanalytic training in Prague with Annie Reich and then with Otto Fenichel.

Dosuzkov survived the German occupation of Czechoslovakia from 1939 to 1945, during which he continued to teach and practice psychoanalysis in secret as the only properly trained psychoanalyst in all of Czechoslovakia. Subsequently, he received the professional and moral support of his students in 1946. He then reestablished the Society for the Study of Psychoanalysis, resumed contact with colleagues in other countries, and was appointed training analyst by the International Psychoanalytic Association. From 1946 to 1948 Dosuzkov and his students engaged in intense scientific and therapeutic activity. In 1947 and 1948 Dosuzkov published articles in the *Annales de psychanalyse* (Annals of psychoanalysis), but the 1949 volume never appeared because of the putsch in 1948. Dosuzkov had to go underground again. In 1968, during the Prague Spring, he was finally able to work openly for a short time.

Dosuzkov's interests and scientific activity are important in the study of neuroses and in applied psychoanalysis. Dosuzkov forged the notion of *scoptophobia* as a fourth psychoneurosis and worked on other phobias, which he interpreted in relation to urethral erotism. He also wrote works popularizing psychoanalysis. His work had an immense influence on the introduction of psychoanalysis in Czechoslovakia. He was an indefatigable proponent of psychoanalysis among specialists and to the general public. He was recognized as a representative of the discipline, defending its viewpoints with fervor, even during politically disturbed periods. He was also important for his scientific contributions. As a student of Fenichel, Dosuzkov took an interest in the psychology of the instincts. Owing to his work, psychoanalysis has survived in Czechoslovakia to the present day.

He died in an accident in a railway yard closed to traffic. The circumstances surrounding his death have never been explained.

EUGÉNIE FISCHER AND RENÉ FISCHER

See also: Czech Republic.

### Bibliography

Dosuzkov, Theodor. (1965). Skoptophobie: die vierte Übertragungsneurose. *Psyche*, 19, 537–546.

———. (1965). Über die drei Haupttypen des neurotischen Stotterns. *Acta XIII Congressus therapia vocis et loquelam*, Vienna.

———. (1969). Zur Frage der Dymorphophobie. *Psyche*, 23, 683–699.

———. (1975). Idrosophobia: A form of pregenital conversion. *Psychoanalytic Quarterly*, 64, 253–265.

———. (1979). Skoptophobie bei männlichen und weiblichen Patienten. *Psyche*, 33, 620–633.

## DOUBLE BIND

Gregory Bateson coined the term *double bind* in 1956. In trying to understand the characteristic effects of communication in schizophrenics' families, Bateson and his collaborators identified a specific constraining interaction, the paradoxical injunction that they called the *double bind*.

The double bind fits into one of the three types of paradox, the pragmatic paradox. The effects of the paradox in human interactions were first described by Gregory Bateson, Don D. Jackson, Jay Haley, and John H. Weakland in a document entitled *Toward a Theory of Schizophrenia*, published in 1956. Bateson and his collaborators were looking for sequences of interpersonal experience that could lead to a type of behavior that would justify the diagnosis of schizophrenia.

This is one of the typical cases constructed by Paul Watzlawick from real clinical facts: A mother buys two neckties for her little boy, one green and one blue. The next day the child is in a hurry to sport the green necktie. The mother: "So you don't like the blue tie I gave you?" The next day the boy puts on the blue tie and draws the symmetrical response: "So you don't like the green tie I gave you?" So, on the third day, the child tries to find a compromise solution in order to satisfy his mother's two demands: he puts on the two ties together. And his mother comments: "You poor boy, you're out of your mind. You're going to drive me crazy." This paradoxical injunction, where the double bind mechanism is particularly obvious, clearly shows the annihilating effects on the person at the receiving end.

Antonio J. Ferreira (1960) described one particular form of double bind, the split double bind, observed in the families of young delinquents. The expression "prescribe the symptom" was first introduced in Bateson's group's work on family therapy in schizophrenia. The group showed the paradoxical nature of this technique: the therapeutic double constraint. From a structural point of view, a therapeutic double constraint is the mirror image of a pathogenic double con-

straint. The therapist formulates an injunction of such a structure that it reinforces the behavior that the patient expects to see disappear. A patient presenting persistent headaches (in-depth medical examinations revealed nothing) transmitted the following message through her symptoms and her earlier relations with doctors: “Help me but I won’t let you help me.” The therapist understood that given the history of physicians’ “failures,” any allusion to the help that psychotherapy could provide would predestine the treatment to fail. The patient therefore had to face the fact that her state was incurable. All that the therapist could do was help her learn to live with her pains.

In the nineteen-seventies the notion of paradox was introduced into clinical and theoretical psychoanalysis from several different directions, largely due to Didier Anzieu’s article on *Transfert paradoxal* (Paradoxical transfer) (1975) and Paul-Claude Racamier’s work on humor and madness (1973), and later on schizophrenics’ paradoxes (Congress of Romance-Language Psychoanalysts, 1978).

JEAN-PIERRE CAILLOT

See also: Paradox; Schizophrenia; System/systemic.

### **Bibliography**

- Anzieu, Didier. (1975). Le transfert paradoxal. *Nouvelle revue de Psychanalyse*, 12, 49–72.
- Bateson, Gregory; Jackson, Don D.; Haley, Jay; and Weakland, John (1956). Toward a theory of schizophrenia. *Behavioral Science*, 1, 251–254.
- Ferreira, Antonio J. (1980). Double lien et délinquance. *Changements systémiques en thérapie familiale*. Paris: E.S.F. (Original work published 1960)
- Racamier, Paul-Claude (1992). *Le génie des origines. Psychanalyse et psychoses*. Paris: Payot.
- Watzlawick, Paul; Beavin, Janet Helmick; and Jackson, Don D. (1967). *Pragmatics of human communication*. New York: W.W. Norton.

## **DOUBLE, THE**

The double refers to a representation of the ego that can assume various forms (shadow, reflection, portrait, double, twin) that is found in primitive animism as a narcissistic extension and guarantee of immortality, but which, with the withdrawal of narcissism,

becomes a foreshadowing of death, a source of criticism and persecution.

The figure of the double dates back to primitive civilizations, as shown in legend, but it is also found throughout literature. It was Otto Rank who in his essay on the double (1914) was the first to develop this idea in psychoanalysis, and Sigmund Freud quotes him at length in “The Uncanny” (1919). However, the idea of the doubling of consciousness is present in his first texts on hysteria (1893, 1895), and the unconscious itself is introduced by Freud as a second consciousness capable of producing dreams, parapraxes, and so on. The theme of the double is taken up by Freud and integrated in his concept of the uncanny. “The ‘uncanny’ is that form of terror that leads back to something long known to us, once very familiar” (1919), but has become terrifying because it corresponds to something repressed that has returned. “The double,” Freud wrote citing Heinrich Heine, “has become an image of terror, just as, after the collapse of their religion, the gods turned into demons.” (1910).

Rank’s study of the double has two aspects: anthropological and psychopathological, the latter being approached through literature and the personality of authors. For anthropology, the double is omnipresent as a representation of the soul and therefore a guarantor of survival. It also helps us understand the nature of sacrifice, such as the cannibalistic incorporation of the son by the father (Chronos) because the son has drawn to himself the father’s image or shadow. The double is similarly the origin of certain taboos, and Rank notes the evolution between the narcissistic claim of immortality and the acceptance of the genetic continuity of parents through their children, which is at the origin of totemism. “It is no longer the double itself (the shadow) that continues to live but the spirit of a dead elder who is reborn in the embryo” (Rank, 1914).

In literature (E.T.A. Hoffmann, Edgar Allen Poe, Guy de Maupassant, Alfred de Musset, Fyodor Dostoevsky), Rank points out the description of a paranoid state revolving around the persecution of the ego by its double and compares these imaginary creations to their authors’ symptoms, through which the theme of the double reveals a psychopathological dimension (epilepsy, splitting of the personality). Similarly, Freud noted that an older form of narcissism that has been overcome can continue to have an effect by changing into a “moral conscience” susceptible of being split off

from the ego, as seen, for example, in delusions of being watched.

The double is also found, although on a different plane, in real or imagined twins and, more generally, in twin brothers. The paradox of identity versus alterity arises here together with—in the case of the doubles of myth who are not brothers (Achilles and Patroclus, Orestes and Pylades)—the narcissistic foundations of friendship. This can be contrasted with the tragic destiny of Narcissus, who drowned while looking at his own reflection. The theme of the double appears, therefore, to be susceptible to very broad interpretation, similar to the primal narcissism from which it originated.

SOPHIE DE MIJOLLA-MELLOR

See also: *Don Juan and the Double*; “‘Uncanny,’ The”.

### **Bibliography**

Freud, Sigmund (1919h). *The Uncanny*. *SE*, 17: 217–256.

Rank, Otto (1914). *The double: A psychoanalytic study*. Chapel Hill: University of North Carolina, 1971.

(1992). *Topique*, 49.

## **DOUBT**

The distinction between doubt as an instrument of rational thought and pathological doubt was known to philosophers (Descartes, Spinoza) long before Freud, and had long been studied as a symptom or syndrome in psychiatry. Théodule Ribot defined doubt as “a conflict between two tendencies in thought, incompatible and antagonistic, without any possible reconciliation, into a succession of positive and negative judgments about the same subject that does not culminate in a conclusion” (1925). In his study on obsessional neurosis, Freud noted that “[a]nother mental need . . . obsessional neurotics . . . is the need for uncertainty in their life, or for doubt” (1909d, p. 232).

Freud first discussed doubt in his work on dreams where he saw it as a mark of resistance and an indication to the analyst of the significance of the repressed element to which it related. But for the most part Freud considered doubt in the context of obsessional neurosis, where it applied to events that had already occurred, and could be seen above all as an expression

of ambivalence, a repudiation of the instinct for mastery as sublimated into an instinct for knowledge (1913i, p. 324).

The etiology of doubt as a symptom is analyzed at length in the case history of the “Rat Man” (1909d). Freud summarized it in a letter of April 21, 1918, to Lou Andreas-Salomé: “The tendency to doubt arises not from any occasion for doubt, but is the continuation of the powerful ambivalent tendencies in the pre-genital phase, which from then on become attached to every pair of opposites that present themselves” (1966/1972, p. 77).

Obsessional thought, however, to characterize it more accurately, has three somewhat different aspects: uncertainty, hesitation, and doubt. Uncertainty can be viewed as that voluntary blurring of references, which underpins the aversion for watches, for example. Doubt, for its part, is an internal perception of indecision, which just like hesitation is associated with the volitional sphere, whereas uncertainty belongs to the cognitive and doubt to the affective. These three aspects do not necessarily function simultaneously, as witness the fact that we can be certain yet unable to decide on action; at the same time, action can overcome hesitation in the absence of the slightest certainty about the reasonableness of that decision. The essence of wisdom would be to achieve certainty before abandoning hesitation—the precise attribute obsessionals find it so hard to adopt (Mijolla-Mellor, 1992).

Apropos of the Rat Man, Freud mentions the “predilection for uncertainty” of obsessional neurotics who turn their thoughts to “those subjects upon which all mankind are uncertain and upon which our knowledge and judgments must necessarily remain open to doubt” (1909d, p. 232–33). This tendency extends to easily accessible knowledge, seemingly as a form of protection against the risk of knowing. In fact the obsessive neutralizes any idea, any decision, by evoking its opposite. Thus hesitation and the predilection for uncertainty constitute the cognitive aspect of the impossibility of choosing, an attitude that serves to delay action indefinitely. The obsessive is paralyzed by ambivalence, immobilized by two instinctual impulses directed at the same object.

What is the source of this ambivalence? Since it is too general a concept to determine the “choice of neurosis,” Freud offered a hypothesis based on constitutional factors: “The sadistic components of love have,

from constitutional causes, been exceptionally strongly developed." And in terms of individual history, these "have consequently undergone a premature and all too thorough suppression" (1909d, p. 240).

Serge Leclaire (1971) has made significant contributions to our understanding of the nature of doubt in the obsessive individual, which he sums up rather laconically as "He doubts because he knows."

SOPHIE DE MIJOLLA-MELLOR

*See also:* Certainty; Intellectualization; Mahler, Gustav (meeting with Sigmund Freud); "Notes upon a Case of Obsessional Neurosis" (Rat Man); Obsession; Obsessional neurosis.

### **Bibliography**

Freud, Sigmund. (1909d). Notes upon a case of obsessional neurosis. *SE*, 10: 151–318.

———. (1913i). The disposition to obsessional neurosis: a contribution to the problem of choice of neurosis. *SE*, 12: 311–326.

Freud, Sigmund, and Andreas-Salomé, Lou. (1972). *Sigmund Freud and Lou Andreas-Salomé; letters*. (Ernst Pfeiffer, Ed. and William and Elaine Robson-Scott, Trans.). New York: Harcourt Brace. (Original work published 1966)

Janet, Pierre. (1909). *Les Névroses*. Paris: Flammarion.

Leclaire, Serge. (1971). *Démasquer le réel*. Paris: Le Seuil, "Champ freudien."

Mijolla-Mellor, Sophie de. (1992). *Le Plaisir de pensée*. Paris: Presses Universitaires de France.

---

## **DREAM**

The dream, guardian of sleep, provides disguised satisfaction for wishes that are repressed while we are awake; dream interpretation is the "royal road that leads to knowledge of the unconscious in psychic life." Such, in highly condensed form, is Freud's theory as set forth in the founding work of psychoanalysis, *The Interpretation of Dreams* (1900a). As Freud himself pointed out, this was a revolutionary thesis.

The only scientists interested in dreams during the late nineteenth century were psychologists looking for "elements" of mental activity or psychiatrists interested in hysteria and hypnosis. All of them saw dreams as nothing more than degraded products of a weak and thus dissociated psyche. Freud's approach was a

radical departure for he claimed that hysterical symptoms were the expression of "conflicts," and that dreams were the product of a "dream work." In both cases there was no weakening of psychic activity but quite the opposite, an intense activity driven by the opposition between wishes and psychic defense mechanisms. The radical nature of Freud's position was illuminated by his divergence from Josef Breuer, who saw hysteria as the product of "hypnotic states" brought on by a weakening of organizing mental activity and a concomitant decrease in what Pierre Janet called "mental tension" (Freud and Breuer, 1895d).

Freud conceived his theory of dreams very early. His exposure to the work of Charcot and later to that of Bernheim was undoubtedly a contributing factor. In 1892 he noted that many dreams "spin out further associations which have been rejected or broken off during the day. I have based on this fact the theory of 'hysterical counter-will' which embraces a good number of hysterical symptoms" (1892-94a, p. 138). ("Counter-will," meaning an opposition to the satisfaction of desire for moral reasons, was a conceptual forerunner of repression.) The "Project for a Scientific Psychology" (1950c [1895]) introduced a number of ideas about dreams that were later expanded and refined.

Between 1897 and 1900 Freud, with moral support from his correspondent Wilhelm Fliess, conducted the self-analysis that gave birth to psychoanalysis. For the most part, that self-analysis drew on Freud's own dreams (Anzieu, 1975/1984), and in due course those same dreams supplied a large portion of the material of *The Interpretation of Dreams*.

Freud's dream theory may be summarized as follows:

1. The dream expresses a wish unsatisfied during the waking state, whether because of a conscious objection or, more frequently, because of repression, in which case the wish is unrecognized. During sleep, the psychic apparatus finds its natural tendency, which is to reduce tension, that is, to experience pleasure. The dream, like hysterical symptoms, slips, parapraxes, and so on, is a sign of the return of the repressed. Freud went further still, claiming that every dream was the fulfillment of a wish, which obviously invites an objection about unpleasurable dreams and anxiety dreams. On several occasions Freud rebutted this objection, continuing to analyze such dreams

until he isolated a wish behind distress or anxiety, which he claimed were merely expressions of resistance and conflict. Truth to tell, his argument was not always persuasive. On the basis of necessarily fragmentary material, it sometimes gave an impression of the ad hoc. Freud was able to overcome this difficulty only much later, when he introduced the repetition compulsion that lay “beyond the pleasure principle” (1920g).

2. Two circumstances favor this return of the repressed. The first is the inhibition of perception and motricity during sleep, protecting the dreamer against the dangers of actual satisfaction. This results in a “topographical regression,” that is, the excitation flows back unto the psyche and reinforces the dream-work. The second circumstance is that sleep weakens the censorship.
3. A measure of censorship remains, however, and often allows satisfaction of a disguised kind only. This is the function of the “dream-work.” This work employs the mechanisms of condensation and displacement (primary processes) before proceeding to generate images (representability). Then, by means of secondary revision, the “dream façade” is improved to provide a plausible meaning; i.e., the manifest content of the dream, which is quite different from the underlying meaning, that of the “latent dream-thoughts.” The dream work is a form of thinking, but its rules are very different from those that prevail in the logical thought of the waking state: dreams know nothing of contradiction.
4. The dream thus provides an outlet for libidinal pressure. It is the “guardian of sleep” since, without its intervention, the pressure would awaken the dreamer.
5. The dream’s raw materials are “day’s residues” (events, thoughts, or affects from the recent past) and physical sensations that occur during sleep. But its “real” content is reactivated infantile memories, especially those of an oedipal kind: the dream is a regression to an infantile state.

These tenets underpin dream interpretation, whose aim is to render meaningful elements in the dream’s manifest content (to restore their latent meaning), on the basis of the dreamer’s associations. Freud insisted that any “key to dreams,” that is, any list of symbolic

equivalents of supposedly general value, be excluded. He did, however, recognize some universal “symbols,” transmitted by culture, and some “typical dreams” to be met with in many dreamers (dreams of nudity, for example).

ROGER PERRON

*See also:* Action-(re)presentation; Agency; Alpha function; Anticathexis/counter-cathexis; Beta-elements; *Beyond the Pleasure Principle*; Breton, André; Censorship; Certainty; “Claims of Psychoanalysis to Scientific Interest”; Compromise formation; Condensation; Contradiction; *Delusions and Dreams in Jensen’s “Gradiva”*; Subject’s desire; Directed daydream (R. Desoille); Displacement; Dream and Myth; Dream interpretation; Dream’s navel, the; Convenience, dream of; Nakedness, dream of; “Dream of the Wise Baby;” Dream screen; Dream symbolism; Dream work; Ego ideal; Ego states; Forgetting; Formations of the unconscious; Functional phenomenon; Hypocritical dream; Hysteria; Infantile, the; Inferiority, feeling of; *Interpretation of Dreams, The; Introductory Lectures on Psychoanalysis*; Isakower phenomenon, Jokes; Latent; Latent dream thoughts; Letter, the; Logic(s); Manifest; Metaphor; “Metapsychologic Supplement to the Theory of Dreams”; Metonymy; Mnemonic trace/memory trace; Mourning, dream of; Myth; *Myth of the Birth of the Hero, The*; Narcissistic withdrawal; *New Introductory Lectures on Psychoanalysis*; Nightmare; Night terrors; Oedipus complex; *On Dreams*; Overdetermination; Primal scene; Primary process/secondary process; “Project for a Scientific Psychology, A”; Psychic reality; Psychic temporality; Psychoanalysis of Dreams; Punishment, dream of; Purposive idea; Reality testing; Regression; Repetition; Repetitive dreams; Representability; Representation of affect; Reversal into the opposite; Reverie; Schiller and psychoanalysis; Screen memory; Secondary revision; Secret; Self-state dream; Somnambulism; Substitutive formation; Surrealism and psychoanalysis; Telepathy; Thing-presentation; Thought; time; Training analysis; Trauma; Typical dreams; Unconscious, the; Wish/yearning; Wish fulfillment; Wish, hallucinatory satisfaction of a; Work (as a psychoanalytical notion).

### **Bibliography**

- Anzieu, Didier. (1984). *The group and the unconscious*. (Benjamin Kilborne, Trans.). London and Boston: Routledge & Kegan Paul. (Original work published 1975)
- Diatkine, René. (1974). Rêve, illusion et connaissance. (Rapport). Réponse aux interventions. 1107–1108. *Nouvelle revue de psychanalyse*, 38 (5–6), 769–820. P.L.R. Congrès XXXIV “Le rêve.” Madrid, 1974.



- Freud, Sigmund. (1900a). *The Interpretation of Dreams*. *SE*, 4–5.
- . (1892–94a). Preface and footnotes to the translation of Charcot’s “Tuesday Lectures.” *SE* 1: 129–144.
- . (1920g). Beyond the pleasure principle. *SE*, 18: 1–64.
- . (1950c [1895]). Project for a scientific psychology. *SE*, 1: 281–387.
- Freud, Sigmund, and Breuer, Josef. (1895d). Studies on hysteria. *SE*, 2: 48–106.
- Pontalis, Jean-Bertrand. (1981). *Frontiers in psychoanalysis: between the dream and psychic pain*. (Catherine Cullen and Philip Cullen, Trans.). London: Hogarth Press and the Institute of Psycho-Analysis. (Original work published 1977)

### Further Reading

- Blum, Harold P. (2000). The writing and interpretation of dreams. *Psychoanalytic Psychology*, 17, 651–666.
- Lansky, Melvin R. (Ed. ). (1992). *Essential papers on dreams*. New York: New York University Press.
- Lewin, Betram. (1955). Dream psychology and the analytic situation. *Psychoanalytic Quarterly*, 24, 169–199.
- Reiser, Morton. (1997). The art and science of dream interpretation: Isakower revisited. *Journal of the American Psychoanalytic Association*, 45.
- Solms, Mark. (1995). New findings on the neurological organization of dreaming: Implications for psychoanalysis. *Psychoanalytic Quarterly*, 64, 43–67.

## DREAM INTERPRETATION

The procedure of dream interpretation is based on the theory of the dream’s functions and of the dreamwork outlined in Freud’s great work *The Interpretation of Dreams* (1900a). This book was based in large part on Freud’s own self-analysis of 1896–1897, in which dream interpretation played a leading role (Anzieu, 1975).

For Freud, dream interpretation is based on several basic principles:

- Every dream represents a wish as fulfilled. Thanks to a relative relaxation of censorship in sleep, a dream expresses repressed desires whose satisfaction is forbidden during the waking state. The conflicts involved may be expressed in unpleasant or anxiety-provoking dreams, however.

- The driving force of the dream, unconscious wishes, are rooted in childhood, notably in oedipal conflicts.
- The “dream material” is supplied by “day’s residues”—usually recent events of waking life.
- The dream work transforms this material by means of the primary processes of condensation, displacement, and visual representation, followed on occasion by a secondary elaboration that perfects the “dream façade.”
- Having once transformed into the “manifest content of the dream,” the “latent dream-thoughts,” now unrecognizable, are able to cross the barrier of censorship.
- The scenes thus created have, for the dreamer, all the characteristics of reality; they are hallucinatory in nature.
- The logic governing the dreamwork is very different from that of waking life, and the dream’s manifest content is often incoherent, filled with bizarre or absurd elements.

Interpretation relies on these principles, but it also needs the dreamer’s associations. He or she is therefore asked to associate as freely as possible, to elicit details of the day’s residues used in the dreamwork, to explicate the displacements and condensations, and to understand the choice of the visual images that make up the manifest content. In this way the thoughts latent beneath that manifest contest, the wishes and conflicts underlying the dream, can be unearthed. Special attention should be paid to bizarre or absurd details, for these indicate points where the dream’s work of distortion has been less effective. At the same time, however, Freud cautioned against concentrating on the latent and ignoring the manifest content (1916–17f).

For Freud, the interpretation of dreams was the “*via regia*,” the royal road leading to the unconscious. On several occasions in *The Interpretation of Dreams*, he noted that the procedure should be carried to the extreme, yet the examples he provided could hardly be said to adhere to this recommendation—presumably because these are for the most part his own dreams, and he may have been reluctant to expose the most intimate aspects of his personal life. It is in any case doubtful that such an exhaustion of meaning is conceivable or even desirable. Dream interpretation may well be the royal road to the unconscious,

but the unconscious is inexhaustible. Nor is it desirable for either patient or analyst to claim that the moment has arrived when there is nothing more to be said.

Finally, there are two points that need underscoring:

- Waking interpretation never deals directly with the dream but rather with a dream narrative, that is, a verbal summary of mainly visual images produced in the waking state. The result is often an over-elaboration of the “material” offered for interpretation (Diatkine, 1974).
- During an analysis, some dreams are responses to and echoes of an earlier session or a preparation for a future session. Every such dream bears the stamp of the transference, and this must not be overlooked.

ROGER PERRON

*See also:* Anagogic interpretation; Anticipatory ideas; “Autobiographical Study, An”; “Constructions in Analysis”; Demand; Doubt; Dream; *Five Lectures on Psycho-Analysis*; “Fragment of an Analysis of a Case of Hysteria” (Dora/Ida Bauer); Free association; Freud’s Self-Analysis; “From the History of an Infantile Neurosis” (Wolf Man); Hermeneutics; Interpretation; Irma’s injection, dream of; *Secrets of a Soul*; Over-interpretation; *Psychoanalytic Treatment of Children*; Self-analysis; Sudden involuntary idea.

### **Bibliography**

Anzieu, Didier. (1986). *Freud’s self-analysis* (Peter Graham, Trans.). London: Hogarth and the Institute of Psychoanalysis. (Original work published 1975)

Diatkine, René. (1974). Rêve, illusion et connaissance. (Rapport). Réponse aux interventions pp. 1107–1108. *Revue Française de Psychanalyse*. 38 (5–6), 769–820.

Freud, Sigmund. (1900a). The interpretation of dreams, Parts I and II. *SE*, 4–5.

———. (1916–1917f). A metapsychological supplement to the theory of dreams. *SE*, 14: 217–235.

Pontalis, Jean-Bertrand. (1981). *Frontiers in psychoanalysis: between the dream and psychic pain* (Catherine Cullen and Philip Cullen, Trans.). London: Hogarth and the Institute of Psycho-Analysis. (Original work published 1977)

## **DREAM-LIKE MEMORY**

Psychic reality is the subject of psychoanalysis. It is important to distinguish psychic from external reality, which we perceive through our senses. Wilfred R. Bion refers to psychic reality as *O*. In his 1970 work *Attention and Interpretation* he focused attention on the necessity for analysts to actively disengage from anything that might saturate their minds with sense data or elements rooted in sensorial data, in order to free the mind for psychic reality as much as possible. However, this psychic reality has no sensorial qualities as such, even though it must use sensorial forms to represent itself: anxiety has no color, no taste, no smell. He therefore suggested that analysts be “without memory or desire” because memory and desire are linked to sensorial elements and if analyst’s minds remain attached to these elements they are no longer available to receive the unknown, the mystery, that is, to be in contact with *O*.

Bion distinguished, however, between two forms of memory: “recalled memory” which corresponds to the usual conception of memory, what we know in advance, what we can remember consciously about an event or a person, about the patient who comes for the session, for example; and the “dream-like memory” that springs into the analyst’s mind in the course of the session, without any conscious effort at recollection. This second type of memory is the form that psychic reality takes in order to be representable in the here and now of the session. It has nothing to do with remembering events from the past: “Recalled memory saturates the psychoanalyst’s preconceptions and obscures the goals to the single point where clarity of judgment coincides with the field where it is exercised: the ongoing session [...]. Dream-like memory is the memory of psychic reality and is the stuff of analysis” (Bion, Wilfred R., 1970, p. 70).

Wilfred R. Bion went a step further when he declared that the aim of analysis is not only a knowledge of *O* but “becoming *O*,” insofar as psychic reality cannot be known but only “be been.” He therefore asks analysts not only to be without desire, without memory, but also without knowledge, in order to promote in so far as possible this “becoming *O*” that he calls “evolution.”

DIDIER HOUZEL

**DREAM, LATENT CONTENT OF THE.** *See* Latent

See also: Attention; Bion, Wilfred Ruprecht; Transformations.

### **Bibliography**

- Bion, Wilfred R. (1970). *Attention and interpretation*. London: Tavistock Publications.
- Grinberg, León, Sor, Dario, and Tabak de Bianchedi, Elizabeth. (1991). *New introduction to the work of Bion*. Northvale, NJ-London: Jason Aronson, 1993.
- Symington, Joan, and Symington, Neville. (1996). *The clinical thinking of Wilfred Bion*. London: Routledge.

---

## **DREAM, MANIFEST CONTENT OF THE.** See **Manifest**

---

### **“DREAM OF THE WISE BABY, THE”**

“The Dream of the Wise Baby” is a one-page text that Ferenczi wrote in 1923. It is a description of a typical adult dream, not a fantasy or a myth, regardless of any analogy with the episode of Jesus teaching the doctors of the Law. It recounts a very young child, a neonate, a baby with glasses, who is teaching adults. Although Freud makes no mention of it in the final edition of *The Interpretation of Dreams* in 1926, he does write: “Dreams are so closely related to linguistic expression that Ferenczi has truly remarked that every tongue has its own dream-language. It is impossible as a rule to translate a dream into a foreign language and this is equally true, I fancy, of a book such as the present one.”

A footnote to Ferenczi’s text introduces the notion of children’s “effective knowledge” [*tatsächliches Wissen*] of adult sexuality. If the dream is repeated often it illustrates what Ferenczi was later to call the “traumatolytic function of the dream” more than a sensual reminiscence that the infant may have enjoyed when at the breast. This knowledge poses a question: Is it a knowledge that is linked to a visual or auditory perception, to an autoerotic excitation, or to an intuition in relation with a primal fantasy? The answer was clear for Ferenczi: It is a knowledge that is linked to facts and to prematuration consequent to trauma, thus to an experience of suffering. In “Confusion of Tongues” (1933/1955) he wrote: “The fear of the uninhibited,

almost mad adult changes the child, so to speak, into a psychiatrist [...]. It is unbelievable how much we can still learn from our ‘wise children,’ the neurotics.”

PIERRE SABOURIN

See also: “Confusion of Tongues between Adults and the Child”; Infantile sexual curiosity.

### **Source Citation**

- Ferenczi, Sándor. (1923). Der traum vom “gelehrten Säugling.” *Internationale Zeitschrift für ärztliche Psychoanalyse*, IX, 70.

### **Bibliography**

- Ferenczi, Sándor. (1955). Confusion of tongues between adults and the child. The language of tenderness and of passion. In *Final contributions to the problems and methods of psycho-analysis* (pp. 156–167). London: Hogarth. (Original work published 1933 [1932])
- Freud, Sigmund. (1900a). The interpretation of dreams. Parts I and II. *SE*, 4–5.

---

## **DREAM SCREEN**

It was Bertram D. Lewin, in his article “Sleep, the Mouth and the Dream Screen,” who proposed calling upon “an old familiar conception of Freud’s—the oral libido—to elucidate certain manifestations associated with sleep” (1946, p. 419).

“The dream screen, as I define it,” wrote Lewin, “is the surface on which a dream appears to be projected. It is the blank background, present in the dream though not necessarily seen, and the visually perceived action of ordinary manifest dream contents takes place on it or before it. Theoretically it may be part of the latent or the manifest content, but this distinction is academic. The dream screen is not often noted or mentioned by the analytic patient, and in the practical business of dream interpretation, the analyst is not concerned with it” (p. 420).

In developing his argument Lewin referred to the Isakower phenomenon, recalling that psychoanalyst Otto “Isakower interprets the large masses, that approach beginning sleepers, as breasts” (p. 421). Lewin expanded on this insight as follows: “When one falls asleep, the breast is taken into one’s perceptual world: it flattens out or approaches flatness, and when one wakes up it disappears, reversing the events of its

entrance. A dream appears to be projected on this flattened breast—the dream screen—provided, that is, that the dream is visual; for if there is no visual content the dream screen would be blank, and the manifest content would consist solely of impressions from other fields of perception” (p. 421). At the end of his article, Lewin offered this summary: “The baby’s first sleep is without visual dream content. It follows oral satiety. Later hypnagogic events preceding sleep represent an incorporation of the breast (Isakower), those that follow occasionally may show the breast departing. The breast is represented in sleep by the dream screen. The dream screen also represents the fulfillment of the wish to sleep” (p. 433).

Today, over and above the attempt to link sleep and oral libido, the notion of the dream screen should no doubt be viewed in conjunction with the idea of the introjection of “containers,” and with Didier Anzieu’s discussion of the “skin ego,” with his concepts of the skin as a “projective” or “writing surface” (1985, p. 40), and even with his view of the dream’s function as a film or pellicle.

At all events, the dream screen is an aspect of the dream-work which operates as a “non-process,” and which as such calls for no specific interpretation.

BERNARD GOLSE

*See also:* Cinema and psychoanalysis; Dream; Dream work; Isakower phenomenon, Negative hallucination; Skin-ego; Sleep/wakefulness.

### **Bibliography**

Anzieu, Didier. (1989). *The skin ego*. (Chris Turner, Trans.). New Haven and London: Yale University Press. (Original work published 1985)

Lewin, Bertram D. (1949). Sleep, the mouth and the dream screen. *Psychoanalytic Quarterly*, 15, (4), 419–34.

---

## **DREAM SYMBOLISM**

In the context of psychoanalysis, the idea of symbolism in dreams should be understood in three ways: (1) as pertaining to relatively constant and universal correspondences between the symbol and what it symbolizes within a given culture (and in the view of some, no doubt, within all cultures); (2) as pertaining to symbol/symbolized correspondences specific to a given dreamer and a given dream; and (3) as pertaining to the

processes of symbolization that give rise to the aforementioned correspondences.

In Chapter 6 of his *Interpretation of Dreams* (1900a), Freud devoted a section to “Representation by Symbols in Dreams.” Anyone who read only this section, however, would have a completely mistaken view of the Freudian approach to the interpretation of dreams. For what Freud dealt with here, in essence, were correspondences of the first kind defined above, that is to say representations (to be met with especially in “typical dreams”) whose meanings seemed so invariable from one dreamer to the next that they could be taken as read, even without reference to the subject’s associations. For example, any long or pointed object, any weapon (but also a hat) stood for the penis, and hollow objects for the vagina or, more generally, a woman’s body; similarly, going up a staircase or flying represented sexual excitement, erection or coitus, coming out of a tunnel meant birth, a tooth being pulled related to masturbation, and so on. Nor were these equivalences exclusive to dreams, for they occurred widely too in stories, myths, and folklore, a fact tending to confirm their universal validity. Verbal connections were very common in this context. In the case of masturbation, for instance, vulgar locutions in German embodied a similar symbolism: “*Sich einen ausreissen*,” literally “to pull oneself out,” meant to masturbate (pp. 348n, 388), and so on.

The sheer profusion of examples given by Freud in this section might suggest to an incautious reader that *The Interpretation of Dreams* is nothing but another “dream-book”; in reality, of course, the entire work is a protest against the “decoding” approach to dream interpretation. Indeed Freud repeatedly stresses that, even if an initial interpretation may be based on a sort of a-priori table of correspondences, a symbol is always modulated by the mental activity of the particular dreamer. For symbols “frequently have more than one or even several meanings, and, as with Chinese script, the correct interpretation can only be arrived at on each occasion from the context.” (p. 353). Beyond the very first or “symbolic” reading, therefore, it was essential, in Freud’s view, to draw out the dreamer’s associations.

The dream work is the task of inserting into each dream the wish which lies at its origin, without offending the conscious mind. Representations in dreams are constructed in the two phases of this transformation: the primary-process phase (condensation, displacement, considerations of representability) and the phase of the

secondary revision which completes the transformation by giving consistency and an acceptable meaning to the manifest text of the dream. The meaning of a given representation can therefore as a general rule be established solely by working in reverse, by de-condensation, so to speak, by re-placing what has been displaced, and so on, on the basis of the associations of the dreamer and the intervention of the analyst.

Processes of symbolization organize the dream-work. Consequently, the whole of *The Interpretation of Dreams*, indeed all Freud's writings on dreams, may be considered to have them as their subject; beyond that, these processes constitute the very core of Freud's metapsychology (Gibeault, 1989).

Works on dreams since Freud have been extremely numerous, dealing notably with the issue of the articulation between "general symbols" and "individual symbols." Ernest Jones (1916/1920) was one of the first to take up this discussion.

ROGER PERRON

*See also:* Dream; *Interpretation of Dreams, The; Introductory Lectures on Psychoanalysis*; Symbol; Symbolism; Translation.

### **Bibliography**

Freud, Sigmund. (1900a). The interpretation of dreams. *SE*, 4–5.

Gibeault, Alain. (1989). Destins de la symbolization. *Revue française de psychanalyse*, 49 (3), 1493–1617.

Jones, Ernest. (1920). The theory of symbolism. In *Papers on psychoanalysis*. New York: W. Wood. (Original work published 1916)

Pasche, Francis. (1960). Le symbole personnel. In *À partir de Freud*. Paris: Payot.

---

## **DREAM WORK**

Freud introduced the notion of "dream work" to clearly emphasize that the dream is not the result, as was generally thought to be the case, of a weakened state of mental activity producing incoherent fragments, but, on the contrary, the outcome of very complex psychic work.

This was the notion that was articulated in *The Interpretation of Dreams* (1900a), based on a fundamental hypothesis: the dream represents a fulfillment

of desires that are repressed in waking life, but this realization is typically disguised so as to pass through censorship during sleep. The "dream work" is responsible for this disguise.

The "materials" used in this process are essentially of two types: residues of the day, that is to say "mnemonic traces" of events, thoughts, affects, etc., of waking life (usually recent), and bodily sensations during sleep (hunger, thirst, pain, etc., but particularly erotic excitation). The source of the dream, however, is to be found in conflicts and wishes of childhood—oedipal conflicts prominent among them.

The dream work proceeds in two phases. The first phase is that of the primary processes: "condensation," resulting in compressing into a single image disparate, even contradictory material (events, personages, representations, affects, etc.); "displacement," whereby an affectively neutral representation is substituted for another, and finally visual imagery is primarily the mode of representation for thoughts, affects, and sensation. There is the passage into images itself, or "representability": the dream is made up of essentially visual sensorial images. Condensation and displacement use a stock of easily available images, which are residues of the day.

The first phase of the dream produces the manifest content, which is the unrecognizable translation of the "latent thoughts" that can be made conscious through analysis. However, the manifest content has to be subjected to a secondary revision upon awakening in order to create a superficial coherence in the remembered and repeated dream.

It is significant that while Freud described these primary and secondary processes as the two phases of the dream work, he also considered them as the two processes governing mental activity: the "primary processes," characterized by the free flowing of an unbound energy; and "secondary processes," dominated by rational intellectual activity and bound energy. Consequently, there is a wide chasm between the primary and secondary processes that can be revealed by dissection of the dream work (Neyraut, 1978, 1997).

ROGER PERRON

*See also:* Cinema and psychoanalysis; Dream; *Jokes and their Relation to the Unconscious*; "Mourning and Melancholia"; Neurotic defenses; Representability, work of; Symptom-formation; Work (as a psychoanalytical notion).

### Bibliography

- Grinstein, Alexander. (1968). *On Sigmund Freud's dreams*. Detroit: Wayne State University Press.
- Neyraut, Michel. (1978). *Les logiques de l'Inconscient*. Paris: Hachette.

### "DREAMS AND MYTHS"

This essay is an exercise in applied psychoanalysis: reference can be made to introduction to the "Essays in Applied Psychoanalysis" written by Sigmund Freud in the first edition of *Delusions and Dreams in Jensen's "Gradiva"* (1907a [1906]), as well as to Freud's essay "Creative Writers and Day-dreaming" (1908e [1907]). Abraham's essay can be compared to Franz Riklin's "Réalisation de désir et de symbolisme dans le conte" (Desire and symbolism in tales; 1908).

Abraham compared collective myths with dreams and located the following similarities: both make use of symbolic imagery; both are the products of human fantasy aimed at the fulfillment of wishes; both are subject to censorship and the same defense mechanisms: "Myths are what survives of the psychic life of peoples; dreams are individual myths," he wrote. This same theme was subsequently discussed by Otto Rank, Theodor Reik, and Géza Róheim before interest in it faded.

JOHANNES CREMERIUS

See also: Abraham, Karl; Applied psychoanalysis and the interaction of psychoanalysis; Dream; Myth; Mythology and psychoanalysis; Primitive.

### Source Citation

Abraham, Karl. (1949). Dreams and myths: a study in race psychology. In *Selected papers of Karl Abraham, M.D.* (Douglas Bryan and Alix Strachey, Trans.). London: Hogarth Press and the Institute of Psycho-analysis. (Original work published 1909)

### Further Reading

Wangh, Martin. (1954). Day residue in dream and myth. *Journal of the American Psychoanalytic Association*, 2, 446–452.

### DREAM'S NAVEL

In *The Interpretation of Dreams* (1900a), Freud wrote, "There is often a passage in even the most thoroughly

interpreted dream which has to be left obscure; this is because we become aware during the work of interpretation that at that point there is a tangle of dream-thoughts which cannot be unraveled and which moreover adds nothing to our knowledge of the content of the dream. This is the dream's navel, the spot where it reaches down into the unknown" (p. 525).

This careful formulation seems to contradict Freud's whole approach to analyzing dreams, which is to take the analysis as far as possible. As he later wrote when discussing the Wolf Man's dream, "It is always a strict law of dream interpretation that an explanation must be found for every detail" (1918b, p. 42n).

It is therefore unsurprising that Freud, rather than accept "the unknown" as a barrier, should wonder whether a given patient's resistance indicated failure stemming from the inadequacy of the analyst or of the analytic method themselves. In "Notes on Dream Interpretation" (1925i) he returned to the issue, pondering "the limits to the possibility of interpretation of the interpretable" (p. 127). There he stressed, "Those dreams best fulfil their function [to satisfy a wish in spite of the ego] about which one knows nothing after waking" (p. 128) or that are quite simply forgotten. They therefore appear to be uninterpretable. All the same, "it sometimes happens, too, that after months or years of analytic labour, one returns to a dream which at the beginning of the treatment seemed meaningless and incomprehensible but which is now, in the light of knowledge obtained in the meantime, completely elucidated" (p. 129).

ROGER PERRON

See also: Analyzability; Incompleteness; Over-interpretation; Real, the (Lacan); Surrealism and psychoanalysis.

### Bibliography

- Dadoun, Roger. (1972). Les ombilics du rêve. *Nouvelle revue de psychanalyse*, 5, 239–254.
- Freud, Sigmund. (1900a). The interpretation of dreams. *SE*, 4: 1–338; 5: 339–625.
- . (1918b). From the history of an infantile neurosis. *SE*, 17: 1–122.
- . (1925i). Some additional notes on dream interpretation as a whole. *SE*, 19: 123–138.
- Rosolato, Guy. (1978). *La relation d'inconnu*. Paris: Gallimard.

## DRIVE/INSTINCT

“The whole flux of our mental life and everything that finds expression in our thoughts are derivations and representatives of the multifarious instincts [drives] that are innate in our physical constitution” (Freud, 1932c, p. 221).

“[T]he “instinct [drive]” appears to us as a concept on the frontier between the mental and the somatic, as the psychical representative of the stimuli originating from within the organism and reaching the mind, as a measure of the demand made upon the mind for work in consequence of its connection with the body” (Freud, 1915c, pp. 121–122).

The German verb *Treiben* generally means “to set into motion”; its earliest meaning was “to drive cattle.” The verb was also used to refer to getting plants to grow, to stamp metal, to drill a mineshaft, to practice languages, to do business, to spend money, to act up—German uses *Treiben* for each of these. Likewise to propel someone into flight, to push someone to the limit, or to feel pressured to do this or that.

The noun *Trieb* shows the same range of force and diversity. Sprout, shoot, or offshoot, for plants; impulse, tendency, penchant, inclination, and instinct for animals and humans—these are all described by the word *Trieb*, which also becomes pejorative when someone gives in to his or her appetites. *Triebleben* means “instinctual life,” and *Triebhaft* means “instinctive.” In physics, *Trieb* means “motor force,” and it appears in a number of compounds such as *Triebfeder*, “mainspring,” *Triebkraft*, “driving force.” *Triebstoff*, literally “driving stuff,” means “fuel.”

Although James Strachey chose to translate *Trieb* by “instinct,” the English word “drive,” like its German counterpart, is in everyday use. It involves the inherent principle of change and activity in living beings. From a dynamic point of view, it is very similar to the ancient Greek concept of *physis*. In 1780, Schiller wrote about *Trieb* in an essay that was well known to Freud and included the passage, “The animal drives awaken and expand the intellectual drives.” Freud often quoted Schiller’s poem “Die Weltweisen” when referring to “the influence of the two most powerful motive forces—hunger and love” (1899a, p. 316).

Freud coined more than forty-five expressions based on the word *Trieb*, such as *Triebkonflikt*, Strachey’s “instinctual conflict.” Further, he qualified drives in

myriad ways, including the sexual drives, the ego-drives, the drive for self-preservation, the aggressive drives, the drive for power, the drive for mastery, the destructive drive, the life-drive, the death-drive, the drive for knowledge, and the social drive. This list does not even include the classification of the partial drives. Nor does it refer to the theory of the drives, Freud’s *Trieblehre*. Finally, *Trieb* designates either the dynamics underlying a specific mental dynamic, in which case Freud spoke of a *drive* or *drives* manifested in “instinctual impulses” (1915c, p. 124); or, alternatively, it designates an overarching dynamic, in which case he referred to the drive or to the *life-drive* and the *death-drive*.

Language provides us with a constant aspect of the meaning of “drive”: the motor principle inherent in living organisms that underlies, in the last instance, all their actions. A drive is activity.

As soon as the concept of libido was introduced, in 1894, as psychical sexual excitation, a rough sketch of the sexual drive became necessary so that the “concept of the mechanism of anxiety neurosis can be made clearer” (Freud, 1895b [1894], p. 108). At first, the sexual drive belonged to the conceptual level. It signified a relatively continuous change of phase and location that transformed the energy of the organic sexual processes into psychical sexual energy, or libido. The sexual drive refers to this transition and its dynamic; it is the conceptual referent of the libido.

Three constants soon appeared. Drive and theory: “drive” is a fundamental concept, necessary for the dynamic understanding of psychical processes. It is inferred from its effects, just like magnetic or gravitational fields in physics. Drive and biology: the theory of the drive is the part of psychoanalytic theory that, since it is founded on somatic processes, borders on biology (Brown-Séquard’s experiments of 1899 were not unknown to Freud). Drive, sexuality, and libido: Freud’s entire work is concerned with the sexual drive. Regardless of the structural oppositions into which it is introduced, it remains the preeminent dynamic referent of human mental life, and as such, is expressed as libido.

Though Freud was later to sharpen and to elaborate it, the concept of the drive was transgressive as early as 1894, and in at least three different senses:

1. It highlighted the importance of sexuality in human mental life.
2. It subverted the body/mind dualism.

3. And by so doing, it reestablished, in the manner of Aristotle and contemporary mathematicians and physicists, the primacy of the dynamic factor in the realization of stable and individualized forms.

Freud distinguished three successive “steps” in the theory of the drives: an “extension of the concept of sexuality,” “the hypothesis of narcissism,” and the “assertion of the regressive character of [drives]” (1920g, p. 59). We can trace these steps in his major works: first, *Three Essays on the Theory of Sexuality* (1905d); next, “On Narcissism: An Introduction” (1914c) and the metapsychological papers of 1915, published in 1924; and finally, *Beyond the Pleasure Principle* (1920g). The first step dissected the sexual drive into component partial drives and emphasized the importance of infantile sexuality. The second step generated new psychic formations of larger dimensions, beyond the basic level, such as the ego and narcissism. At this stage, a difficulty developed regarding the drive’s dualism; nevertheless, the drive, its pressure, and its psychical representatives were clearly defined. The third step established the life-drive and the death-drive, a dualism of vast proportions under which all of mental life and all matter was now subsumed. At each step, Freud expanded the drive’s domain without abandoning previous knowledge or more limited perspectives.

Freud’s “thorough study of the . . . essential characters of the sexual [drive] and . . . the course of its development” (1905d, p. 173), took him far beyond both language and tradition, and on the basis of this research he founded the dynamics of psychoanalysis. The theory of the drives was so crucial that Freud—in contrast to his practice with his other fundamental works—continually revised the *Three Essays* as the theory evolved, until the edition of 1924, which introduced such concepts as the phallic stage and primary masochism. Nevertheless, the elements constituting the theory of psychoanalysis could have been taken as established as early as 1905, if we can rely on Freud’s recollection in 1924: “They are: emphasis on instinctual life (affectivity), on mental dynamics, on the fact that even the apparently most obscure and arbitrary mental phenomena invariably have a meaning and a causation, the theory of psychical conflict and of the pathogenic nature of repression, the view that symptoms are substitutive satisfactions, the recognition of the etiological importance of sexual life, and in particular of the beginnings of infantile sexuality” (1924f, p. 198).

These factors depend on the theory elaborated in the *Three Essays*, as the order of their enumeration indicates. The sexual drive was first dissociated from its “natural” object, an adult of the opposite sex, and then broken down into partial drives that appear in infancy, the oral drive, the anal-sadistic drive, and so on. They are defined by their source, which is a bodily erogenous zone; their aim, which is the cessation of their excitation through discharge; and their object, which is the most variable factor. The possible paths that they can take are diverse: foreplay in adult sexual activity; repression and symptomatic expression in the neuroses; fixation and exclusivity in the perversions; and finally all the defensive formations—reaction-formation, inhibition as to their aim, sublimation, and so on. Thus the diversity of adult sexuality is clarified by its “polymorphously perverse” infantile development—and the opposition between the normal and the pathological is eliminated. The two stages in the constitution of human sexuality, first early childhood and then puberty, explain the “damming up” of the drive’s energy and the psychical development of the individual by the establishment of defenses at the expense of the sexual drives. “The simplest and likeliest assumption as to the nature of the instincts would seem to be that in itself an instinct is without quality, and, so far as mental life is concerned, is only to be regarded as a measure of the demand made upon the mind for work” (1905d, p. 168). The variability and plasticity of the drive’s dynamics are essential to this work, since it views the development of the person and of culture on the course of drive development.

Regarding the enlargement of the concept of sexuality, Freud wrote: “These facts could be met by drawing a contrast between the sexual instincts [drives] and ego instincts [drives] (*instincts [drives] of self-preservation*) which was in line with the popular saying that hunger and love make the world go round: libido was the manifestation of the force of love in the same sense as was hunger of the self-preservative [drive]. The nature of the ego instincts remained for the time being undefined and, like all the other characteristics of the ego, inaccessible to analysis” (1923a [1922], p. 255). As one component of psychic conflict, the drives of the ego were therefore indispensable.

Proceeding with the investigation of the drives in 1911 with the Schreber case, Freud at first saw himself as “defenseless,” because the concept of libidinal investment in the ego seemed to undo the dualism of



the drive. “Thus the instincts [drives] of self-preservation were also of a libidinal nature: they were sexual instincts [drives] which, instead of external objects, had taken the subject’s own ego as an object. . . . The libido of the self-preservative instincts was now described as *narcissistic libido* and it was recognized that a high degree of this self-love constituted the primary and normal state of things. The earlier formula laid down for the transference neuroses consequently required to be modified, though not corrected. It was better, instead of speaking of a conflict between sexual instincts and ego instincts, to speak of a conflict between object-libido and ego-libido, or, since the nature of these instincts [drives] was the same, between the object cathexes and the ego” (1923a [1922], p. 257).

From 1914 to 1920, there is no longer a dualism of the drive. The continuous and constant pressure of the drive—along with the pleasure principle—was sufficient to generate the psychic dynamics as well as the diversity of psychical formations (by means of anti-cathexis and primal repression). “By the pressure [*Drang*] of an instinct [drive] we understand its motor factor, the amount of force or the measure of the demand for work which it represents. The character of exercising pressure is common to all instincts [drives]; it is in fact their very essence” (1915c, p. 122). In universalizing the *drive* as a potential state underlying the psyche, Freud also accounted for the way in which *drives* manifest themselves: They are the workings of the drive in the unconscious, and the twofold determination of its representatives revealed by repression: ideas and quota of affect.

Dissatisfied with this situation, which is monist at the dynamic level and dualist in the effects it brings about (though such a dualism is common in any qualitative dynamics), Freud hypothesized: “On the ground of far-reaching consideration of the processes which go to make up life and which lead to death, it becomes probable that we should recognize the existence of two classes of [drives], corresponding to the contrary processes of construction and dissolution in the organism” (1923a, p. 258). In *Beyond the Pleasure Principle* (1920g), he constructed a space in which the substrate is inert matter plus living substance, on which the two types of dynamics act. One refers to pure stability: the death-drives. The other refers to a continuity and to a flexible stability in living beings that continue to exist: the life-drives, or Eros. This space accommodated a

psychical apparatus that was enlarged to include the id, ego, and superego, in which the fundamental drives appeared as libido, as destructiveness and masochism; or even, as Freud put it: “For the opposition between the two classes of instincts we may put the polarity of love and hate” (1923b, p. 42).

From that point on, this model of the dynamics and space of the drive was sufficient. But the theory of the life-drives and death-drives still included propositions too diverse to fit within this model. Several factors remained to be accommodated: the necessity of constructing a space of sufficient dimensions to accommodate all the psychical processes; the fundamental idea of the plurality of the dynamics of psychical work; and finally the necessity of introducing, at the dynamic level, the stability, and even the stabilization, that constitutes, via the “fixation” of a drive, the essence of symptoms and the constraint of repetition. Thus the death-drive includes, among other things, the “instinctual” aspect of the drive. Even though this distinction between drive and instinct is obscured in English by Strachey’s translation, the death-drive integrates the “conservative” and “regressive” nature of instinct. Moreover, this model emphasizes the essential role of the repression of destructive drives in cultural development; it explains the process of the internalization of aggression in the superego; and it explains the origin and the dangers of guilt feelings.

The prevailing qualitative dynamics recognizes what could be called, borrowing a term from the mathematician Seifert, the “fiber spaces” in drives. These include the dynamics out of which the actual forms of the drive develop. From this point of view, it is obvious that any psychoanalytic concept depends, in the final instance, on the theory of the drives. Thus it is consistent that the first ontogenesis of the purified ego appeared in “Instincts and Their Vicissitudes.” Moreover, it was necessary that this paper opened the metapsychology and preceded the essays on repression, the unconscious, dreams, and mourning and melancholia. Likewise, it was necessary to propose the theory of life-drives and death-drives in order to construct the second topography. The pleasure principle itself depends on the death-drive. The constant updating of the *Three Essays* makes it obvious that the theory of the drive is at the basis of the entire theoretical edifice.

What is missing in the theory of the drives is a dimension that would accommodate all of psychical dynamics and economics—for example, reality, to

which Freud conceded an economic and dynamic status that he continually returned to during the years 1923–1925. He reevaluated its role in the constitution of the neuroses and psychoses, and then he reworked the theory of anxiety, and described a realistic anxiety (*Realangst*).

The transgressive features of the drive, listed above, indicate the ways in which it has been critiqued. The accusation of pansexualism is easy to refute: “. . . it is a mistake to accuse psycho-analysis of ‘pan-sexualism’ and to allege that it drives all mental occurrences from sexuality and traces them all back to it. On the contrary, psycho-analysis has from the very first distinguished the sexual instincts [drives] from others which it has provisionally termed ‘ego-instincts [drives]’ . . . and even the neuroses it has traced back not to sexuality alone but to the conflict between the sexual impulses and the ego” (1923a, pp. 251–252).

In the field of psychoanalysis, it is far more common to reproach Freud for his “biologism,” his supposed emphasis on biology as opposed to the unconscious or language. And thus idealism and the mind/body dualism are reintroduced.

The primacy of dynamics, which places psychoanalysis within the larger tradition of scientific modernism (along with thermodynamics, theories of dynamic systems, and qualitative dynamics), has run into several difficulties. First of all, *Treib* does not have an etymological correspondent except “drive” where the pressure disappears after fixed discharge. Instinct has the same problem, as was demonstrated by Agnès Oppenheimer in her studies of the British “object-relations school.” Without an adequate term, the concept of *das Dynamische* is not communicated. Another obstacle was noted by Freud in 1910: “The most striking distinction between the erotic life of antiquity and our own no doubt lies in the fact that the ancients laid the stress upon the [drive] itself, whereas we emphasize its object. The ancients glorified the [drive] and were prepared on its account to honour even an inferior object; while we despise the activity [of the drive] in itself and find excuses for it only in the merits of the object” (1905d, p. 149). Language, culture, and the various dominant epistemologies (for example pragmatism, empiricism, positivism, and structuralism), by privileging object relations, mask the dynamic point of view.

Conversely, Ferenczi delved into the dynamics of the drive audaciously in his *Thalassa* (1924). Having the term *pulsion* at their disposal as a translation for *Treib* from 1910 on, French-speaking analysts—such

as Jean Laplanche, Jean-Bertrand Pontalis, and André Green—were able to preserve the meaning of the concept and to develop it.

Freud admitted his difficulties with the theory of the drives. In fact, dynamic science remains to this day *extremely* difficult, and the theory of the drives is a work in progress. According to Freud, even the sexual drives, which are the most well known, are still obscure, thanks to their interchangeability. Sublimation remained a difficult concept after Freud (S. de Mijolla-Mellor, 1992), and research on this topic today is still centered on the themes that he discovered.

However much we may accept the Freudian point of view, there is still the death-drive. “A queer [drive] indeed, directed to the destruction of its own organic home!” (1933a [1932], pp. 105–106) If all the demands included in the life-drives and death-drives are admissible (Porte, 1994), a theory of the drives exploiting the facts of qualitative dynamics would distribute them differently. Nothing obliges us to restrict the number of dynamics, and we could suppose the existence of “fast” and “slow” dynamics (Kubie, 1960). Fear would count among the basic affects, along with love and hate, for “It is like a prolongation in the mental sphere of the dilemma of ‘eat or be eaten’ which dominates the organic animate world” (1933a [1932], p. 111).

Elaborating for Einstein “a portion of the theory of the [drives],” Freud noted, “It may perhaps seem to you as though our theories are a kind of mythology and, in the present case, not even an agreeable one. But does not every science come in the end to a kind of mythology like this? Cannot the same be said to-day of your own Physics?” (1933b [1932], p. 211). Thus it is in the sense that every science worthy of the name constructs a mythology, and then controls its expansion, that Freud can speak of “Our mythological theory of [drives]” (p. 212).

MICHÈLE PORTE

*See also:* Activity/passivity; Aggressive instinct/aggressive drive; Anaclysis/anaclyctic; *Beyond the Pleasure Principle*; Binding/unbinding of the instincts; Compulsion; Cruelty; Drive, subject of the; Dualism; Economic point of view; Ego functions; Ethnology and psychoanalysis; Eros; Erotogenic zone; Fixation; Fusion/defusion of instincts; Id; Instinct; “Instincts and Their Vicissitudes”; Instinctual impulse; Instinctual representative (representative of the drive); Look/gaze; Knowledge, instinct for; Mastery, instinct for; *New Introductory Lectures on Psychoanalysis*; Object; “On Narcissism: An Introduction”;

*Outline of Psycho-Analysis An*; Pair of opposites; Principle of constancy; Prohibition; Reversal (into the opposite); Sublimation; *Three Essays on the Theory of Sexuality*; Turning around upon the subject's own self; Turning around; Voyeurism.

### **Bibliography**

- Freud, Sigmund. (1920g) *Beyond the pleasure principle*. *SE*, 18: 1–64.
- . (1923b) *The ego and the id*. *SE*, 19: 1–66.
- . (1915c) Instincts and their vicissitudes. *SE*, 14: 109–140.
- . (1932c) My contact with Josef Popper-Lynkeus. *SE*, 22: 219–224.
- . (1933a [1932]) *New introductory lectures on psychoanalysis*. *SE*, 22: 1–182.
- . (1895b [1894]) On the grounds for detaching a particular syndrome from neurasthenia under the description “Anxiety Neurosis.” *SE*, 3: 85–115.
- . (1899a) Screen memories. *SE*, 3: 299–322.
- . (1924f) A short account of psycho-analysis. *SE*, 19: 189–209.
- . (1923a [1922]) Two encyclopaedia articles: Psychoanalysis and the libido theory, *SE*, 18: 235–259.
- Freud, Sigmund and Einstein, Albert. (1933b [1932]) Why war?. *SE*, 22: 195–215.
- Kubie, Lawrence S. *Practical and theoretical aspects of psychoanalysis*. New York: Praeger, 1960.
- Mijolla-Mellor, Sophie de. (1992). *Le plaisir de pensée*. Paris: Presses Universitaires de France.
- Oppenheimer, Agnès. (1996). *Kohut et la psychologie du self*. Presses Universitaires de France.
- Porte, Michèle (Ed.). (1994). *Passion des formes. Dynamique qualitative, sémiophysique et intelligibilité. À René Thom*. Paris: E.N.S. Fontenay-Saint Cloud.

### **Further Reading**

- Kernberg, Otto. (2001). Object relations, affects, and drives: toward a new synthesis. *Psychoanalytic Inquiry*, 21, 604–619.

---

## **DUALISM**

In the history of religion, dualism refers to the eighteenth-century doctrines that see God and the devil as

two first principles, irreducible and coeternal. Christian Wolff (1734/1968) classified dogmatic philosophies into dualistic systems, which separated the soul from the body as distinct substances, and monistic systems, both groups being distinct from skepticism. In anthropology, epistemology, and ethics, a theory is dualistic when two irreducible principles can serve as a foundation for the theory.

From “A case of successful treatment by hypnotism” (1892–1893) to his last works, Sigmund Freud envisioned mental processes as resulting from underlying conflicts, fed by opposing forces: “Psychoanalysis early became aware that all mental occurrences must be regarded as built on the basis of an interplay of the forces of the elementary instincts” (1923a). In the first topographic subsystem, these forces arise from the sexual instincts in conflict with the ego, or self-preservation, instincts. Later Freud (1914c) said that they arise from the object libido in conflict with the ego libido, as well as from the pressure of the drives. In the second topographic subsystem (after 1920), they arise from the life and death drives. These forces structure the form and dynamics of the mental processes.

Although Freud emphasized the existence of two types of drives in his dualistic approach, he avoids the word “dualism.” Originating in the body, effecting the association of body and mind, and causing physical changes (conversion) or other types of modifications (other defenses), the drives create a dualistic dynamic, though this is not sufficient for saying that psychoanalytic theory is dualistic.

As Freud's research evolved, the essential polarities and the role of instinctual dualism changed as well. When studying the transference neuroses, Freud postulated an “opposition between the ‘sexual impulses’ directed toward the object and other impulses that we can only identify imperfectly and temporarily designate with the name ‘ego instincts’ ” Freud noted the concordance with the opposition between hunger and love. He added, “In the forefront of these instincts, we must recognize the instincts that serve for the preservation of the individual” (1920g). In the first topographic subsystem, these forces arising from instincts were like vectors applied to quasi points (unconscious representations). In this way they resembled the structures of classical physics (Freud, 1899a).

Freud's introduction, between 1911 and 1915, of narcissism, of the ego as agency, of transference (rather than phenomenological transfer), and of a series of correlative

terms of considerable scope shows his dissatisfaction with the former dynamic system. Freud then insisted that antagonistic forces account for morphogenesis, stabilization, and the evolution (in modern terms, structural stability) of large irreducible structures such as the ego, the ego ideal, and certain identifications.

After a period of confusion when Freud replaced the dynamics of conflict with the opposition between object libido and ego, together with the pressure of the drive, Freud proposed the dualism of the life and death drives. A chiasma was introduced, since the sex drive, a disturbing toxic force in the first topographic subsystem, was now integrated in the life drive (*germen*), while the ego instincts (*soma*) were partially integrated in the death drive. The difficulty that this chiasma creates can be resolved by assuming that the new dualism, which is more comprehensive, resolves conflicts between tendencies with different degrees of stability. The ego affects its own immediate stability by conflicting with the expression of sexuality, which forces the ego to change. The sexual drive is directed, in the last instance, at the long-term structural stability of the species.

Drive dualism correlates with a number of conflicts. These include the polarities of mental life: the economic polarity of pleasure and unpleasure, the reality polarities of the ego and the outside world, the biological polarities of activity and passivity. This last pair introduces the polarities around which the contrasts between the sexes develop: active/passive, phallic/nonphallic, masculine/feminine. In ambivalence there is movement between love and hate, and ultimately between the life and death drives; or between the pleasure principle and the reality (formerly constancy) principle, and ultimately between the life and death drives.

The dualism of the life and death drives has often been rejected or poorly understood. It has been interpreted in an exclusively realist sense (Melanie Klein and the Paris school of psychosomatics) even though there was also a theoretical component. The repetition compulsion and death drive have been unilaterally interpreted as nondynamic structural formalisms. Freud's requirements for drive theory involve dynamically accounting for the simple stability that repetition implies (for example, in symptoms) while taking into account the structural stability (always deviating in the same way) that the majority of mental structures implement. "But," according to Freud (1920g), "in no region of psychology were we groping more in the dark [than in the case of the drives]." Only Gustav

Fechner and his hypotheses of stability were of use to Freud. Contemporary dynamicists provide more refined instruments for plumbing the depths of Freudian drive dualism while respecting its preconditions.

MICHÈLE PORTE

*See also:* Ambivalence; *Beyond the Pleasure Principle*; Demand; Destrudo; Ego-instinct; Fusion/defusion of instincts; Libido; Life instinct (Eros); Monism; *Psychology of Women. The, A Psychoanalytic Interpretation, The, Psychosomatic limit/boundary.*

### **Bibliography**

- Freud, Sigmund. (1892–1893). A case of successful treatment by hypnotism. *SE*, 1: 115–128.
- . (1899a). Screen memories. *SE*, 3: 299–322.
- . (1914c). On narcissism: an introduction. *SE*, 14: 67–102.
- . (1920g). Beyond the pleasure principle. *SE*, 18: 1–64.
- . (1923). The libido theory. *SE*, 18: 255–259.
- Laplanche, Jean. (1970). *Vie et mort en psychanalyse*. Paris: Flammarion.
- Wolff, Christian. (1968). *Psychologia rationalis*. Hildesheim, Germany: Olms. (Originally published 1734)

---

## **DUBAL, GEORGE (1909–1993)**

George Dubal, Swiss psychoanalyst and doctor of theology, was born in Geneva on September 18, 1909, and died there on March 9, 1993.

He received a Protestant education. Upon finishing secondary school, he commenced university studies at Eugène Pittard's laboratory, then successively attended the universities of Strasbourg, Geneva, and Paris. He took part in the new-schools movement in French-speaking Switzerland and took a very early interest in psychoanalytic thinking. At the age of sixteen he experimented with the Jungian method of free association. "This method," he wrote in his memoirs, "enabled me to save a comrade from suicide."

He discovered the psychoanalytic experience from one of the first Swiss psychoanalysts, Dr. Gustave Richard of Neuchâtel. He joined Richard, Marguerite Bosseret, and William Perret in creating "new schools" to forward educational reform. Dr. Richard entrusted one of his sons to him for psychotherapy. During this

period Dubal met Charles Baudouin, one of the pioneers of psychoanalysis in Geneva. He went on to become his friend and collaborator. A course of several months spent working in Préfargier Hospital introduced him to the treatment of psychotics. He then encountered Charles Odier, with whom he undertook psychoanalysis. In 1933 he corresponded with Freud on the subject of the libido. He wrote, “In accordance with the concept of general relativity, Freud responded to me that he had no major objection to making a distinction between a general libido and a particular libido.”

In 1935 he married a psychoanalysis buff who wrote various works under the name of Rosette Dubal, among them *La psychanalyse du diable* (Psychoanalyzing the devil) in 1953. Dubal and his wife were both committed to social change and collaborated closely in integrating into social change a psychoanalytic point of view. His psychoanalytic work within the framework of the cure and preventive work outside this context were of equal importance to George Dubal. In fact, like Sándor Ferenczi or Wilhelm Reich, he struggled for the inclusion of psychoanalytic considerations in education and cultural policy.

Before World War II, if we can trust his memories, he was the only practicing psychoanalyst in Lyons, where he became the friend and collaborator of Dr. A. Réquet, head of the Vinatier Clinic. He claims to have introduced psychoanalytic thought to members of the Esprit Group under Frutiger, the president. He also gathered around him friends from the Philosophical Society to discuss the influence of psychoanalysis on philosophical thought. His pedagogical need to reach the general public spurred him on to write a hundred or so pamphlets on psychoanalysis, some of which were published.

In 1953 he made the acquaintance of Marie Bonaparte and John Leuba, who invited him to attend the 15th Conference of French-Speaking Psychoanalysts in Paris and to react to the theory of the instincts propounded by Maurice Bénéssy. Two years earlier he had published in the *Revue française de psychanalyse* (French review of psychoanalysis) a much-appreciated paper titled “La psychanalyse existentielle de Sartre (Sartre’s existential psychoanalysis). As early as 1947 in his book *Psychanalyse et connaissance* (Psychoanalysis and Knowledge) he had analyzed the limits of a phenomenological approach and criticized the finalism of a theory of the instincts as reflected in psychoanalytic practice.

During the events of May 1968, when protests by students at the Sorbonne became violent and led to protests at universities across France and strikes by

French workers, George Dubal defended the students and called into question the relationship between knowledge and power, sparing neither psychoanalysts nor the societies that shelter them. Like some of his Zurich colleagues, he did not share the ideology of those who, as he wrote in his memoirs, “try to put their patients in the party line with respect to power,” to the detriment of respect for the individual.

In the French-speaking Swiss psychoanalytic community, in his practice, as a committed author writing in the journal *Construire* (Building) and the review *Vivre* (Living), and in his conferences at the Artimon, George Dubal was a creative individual who defied all forms of man’s indoctrination and stultification of man.

MARIO CIFALI

See also: Switzerland (French-speaking).

### **Bibliography**

Dubal, George. (1947). *Psychanalyse et connaissance: L'évolution des psychothérapies et la psychanalyse; Le problème de l'instinct; Le problème de la connaissance*. Geneva, Switzerland: Éditions du Mont-Blanc.

Dubal, George. (1960). *Moi et les autres: applications de la psychanalyse à la pédagogie et à la pensée dialectique*. Neuchâtel, Switzerland: Éditions Delachaux et Niestlé.

---

## **DUGAUTIEZ, MAURICE (1893–1960)**

Maurice Dugautiez, a Belgian civil engineer and psychoanalyst, was born near Tournay in 1893 and died in Brussels in 1960. He was born and reared in a middle-class, provincial environment where nothing predisposed him to be a pioneer of psychoanalysis in Belgium except perhaps a passionate curiosity about psychic life. He was an autodidact and initially very enthusiastic about hypnotism and suggestion. He gave many lectures in a socialist politico-cultural forum, which were later printed in the review *Le pédagogue* (The teacher).

During this period, in 1933, he met Fernand Lechat in the course of one of these seminars. The two men became progressively aware of their common interest in psychoanalysis and contacted Édouard Pichon, then president of the Paris Psychoanalytic Society, who encouraged them to do a training analysis with Dr. Ernst Hoffman, a Viennese refugee in Belgium. After the silence of World War II, contact was reestablished with Paris in 1945. Dugautiez and Lechat were invited

as special students to attend the courses of the Paris Psychoanalytic Institute, and by 1946 Dugautiez was a full member of the Paris Psychoanalytic Society.

In 1947 Dugautiez and Lechat founded the Belgian Association of Psychoanalysts, where they began to train and supervise candidate psychoanalysts. As the result of intense gassing in World War I, Dugautiez's health was fragile and forced him to take a less active role. The responsibility of directing seminars and editing the *Bulletin de l'Association des psychanalystes de Belgique* (Bulletin of the Belgian Association of Psychoanalysts) thus fell to Lechat. Dugautiez, who was more of a clinician than a theorist, continued to train Belgian psychoanalysts until the end of his life.

DANIEL LUMINET

*See also:* Belgium

### **Bibliography**

Dugautiez, Maurice. (1953). J. Leuba n'est plus. *Bulletin de l'Association des psychanalystes de Belgique*, 15.

Dugautiez, Maurice. (1953). Réflexions sur l'article "Les tendances de la psychanalyse à New York" du Pr. Reding. *Bulletin de l'Association des psychanalystes de Belgique*, 16.

## **DYNAMIC POINT OF VIEW**

Alongside the topographical and economic points of view, the dynamic point of view is one of the three major axes of metapsychology. It studies the way in which the forces that run through the mental apparatus come into conflict, combine, and influence each other.

The model for mental dynamics was present in Freud's thought from the beginning: it is a direct extrapolation from the dynamic theory of physics in the nineteenth century. It is based on the idea that the mind, with different forces running through it, is the seat of conflict between them. In order to decrease or eliminate the displeasure occasioned by these conflicts, the mental apparatus uses different mechanisms, repression being the prototype. By means of repression the mental apparatus changes the topographical location of the ideational representatives of the instincts. It thus protects itself from the painful or displeasing aspects of its conflicting desires by making some of them or some of their aspects unconscious. The analysis of the dynamics of how mental conflicts are processed is thus an essential component in the practice of psychoanalysis and in metapsychology, which attempts to describe them.

Freud later put forward the idea that, in addition to the defenses that work against but within the conflict, the psyche can implement defense processes that no longer aim at organizing the means to process the conflict but at preventing the conflict itself from appearing. Thus, in addition to repression, which nevertheless retained a generic value in his mind, Freud and many of his successors described forms of projection, denial, even splitting and foreclosure, that attack the very possibility of the existence of a mental conflict by trying to expel from the psyche the existence of one of the components of the conflict.

However, it is also one of the fundamental characteristics of Freud's thinking, as well as that of his principal successors, to simultaneously affirm that in spite of the intensity of the expelling forces that can come to bear on conflicts and their mental representatives, the psyche keeps a trace of what it has tried to expel from itself in this way. That which is expelled tends to come back, in one form or another, often in negative form. Therefore the analysis of mental dynamics must also focus on the measures implemented in order to face up to the internal or external return of what it has sought to remove from representation.

RENÉ ROUSSILLON

*See also:* Conflict; Metapsychology; Repression; Resistance; Wish fulfillment.

### **Bibliography**

Freud, Anna. (1936). *The ego and the mechanisms of defence*. London: Hogarth, 1937.

Freud, Sigmund. (1915d). Repression. *SE*, 14: 141–158.

Green, André. (1993). Analyse primaire dans la relation anale. *La Névrose obsessionnelle*. Paris: Presses Universitaires de France.

Le Guen, Claude, et al. (1986). Le refoulement (les défenses). *Revue française de psychanalyse*, 50 (1), 23–370.

Rosolato, Guy. (1988). *Le négatif, figures et modalités*. Paris: Dunod.

### **Further Reading**

Meissner, William W. (1999). Dynamic principle in psychoanalysis. *Psychoanalysis and Contemporary Thought*, 22, 2–84.



# E E

## EARLY INTERACTIONS

The notion of early interactions between the child and its environment first appeared during the 1970s and has since become widely accepted. The further development of the concept corresponds very closely with the spread of knowledge concerning what is now referred to as the psychology, psychopathology, and psychiatry of the baby (or nursing infant).

The concept was put forward by developmental psychologists and is generally contested by psychoanalysts insofar as it refers more to the field of interpersonal relations than to intrapsychic problems in the strict sense of the term. Psychoanalysts prefer to speak of “interrelations,” a term they use in reference to the constitution of the child’s imagos and the progressive establishment of its mental representations (of self, object, and object relations).

However, the term *early interactions* is now very widely used. It is based on a new vision of the nursing infant, a vision that first appeared toward the end of World War II. Although before that time babies were very largely considered by professionals to be eminently passive beings engaged almost exclusively in oral and digestive functions, they slowly came to be described as being much more active in the relationship and already having an intensely social orientation. They were recognized as having many skills, particularly the personal capacity to engage a relationship with its caregiving adult or, on the contrary, to withdraw from this relationship. Infants use some of these skills spontaneously in their daily lives while others, on the contrary, remain potential, as if in abeyance or on reserve, being manifest only in experimental situations (free motricity, early imitation).

It is this notion of active skills and relational reciprocity (in spite of the indisputable dissymmetry between the psychic organization of very young infants and adults) that gave rise to the concept of an interaction. From being seen as a passive consumer, the baby increasingly came to be considered as an evolving human being. This shift in focus can probably be linked on the one hand to adult guilt feelings with regard to children at the end of the last world war and, on the other, to intensified research into the earliest stages of psychic development as a result of the exacerbating urgency of our quest for origins.

In reality the concept of early interactions covers different levels of facts. Five different levels are classically distinguished in a baby’s interactive system: biological interactions, ethological interactions, whether instinctual or behavioral, affective or emotional interactions, fantasy interactions and, lastly, the so-called symbolic interactions. Early interactions really only related to the first four levels, the last one being more concerned with children who have already acquired the use of language.

Biological interactions come into play very largely during intra-uterine life and are generally referred to as “feto-maternal interactions.” They continue to a lesser degree after birth, particularly in the form of breast-feeding.

Behavioral interactions facilitate the various postural adjustments (in his own day Henri Wallon spoke about the “stimulating dialogue” between the mother and child), as well as the attunement of a certain number of biological rhythms (for example, regulating the contractions of the muscle cells in the mother’s mammary glands with the rhythms of the baby’s crying). They require no humoral mediators.



Affective and emotional interactions enable both the mother (or, indeed, the father for that matter) and the child to harmonize their emotional state with that of the other. The main mechanism coming into play seems to be the process of affective attunement described by Daniel N. Stern.

The level of fantasy interactions has been the subject of the liveliest debates with psychoanalysts insofar as they contest the very idea of the action of fantasies and stress the fundamental dissymmetry in the organization of psychic processes in the adult and the child. The process of affective attunement also appears here as the best current candidate for the role of messenger in these fantasy interactions, a study of which is obviously essential with regard to inter- and trans-generational transmission. In fact this level of fantasy interactions poses the whole question of its role in relation to the complex mechanisms of identification and projective identification.

In Anglo-Saxon countries the study of early interactions continues to be very largely the domain of developmental psychologists (T. B. Brazelton, A. J. Sameroff, R. N. Emde), whereas in other countries, particularly in France, a whole research trend came into being in the wake of Serge Lebovici's (1983) work, mainly in an effort to integrate this concept of early interactions into the data of classic psychoanalytic metapsychology.

The following are the main questions currently raised by the concept of early interactions: Can the different types of interactions between the baby and its environment be considered as first forms or precursors of future object relations? How is the change effected from the interpersonal level to the intrapsychic level? What is the role of these interactions in the child's relation to intersubjectivity? Is there not a danger that the question of interactions will lead to a sort of metapsychology of presence to the detriment of the role of absence and the excluded middle?

BERNARD GOLSE

*See also:* Infant observation; Infant observation (direct); Lack of differentiation; Lebovici, Serge; Sindel Charles; Tenderness.

### **Bibliography**

Lamour, Martine, and Lebovici, Serge (1989). Les interactions du nourrisson avec ses partenaires. *Encyclopédie*

*medico-chirurgicale* (Vol. *Psychiatrie*). Paris: E.M.-C., fasc. 37-190-B-60.

Lebovici, Serge. (1983). *Le nourrisson, la mère et le psychanalyste*. Paris: Le Centurion.

Sameroff, Arnold J., and Emde, Robert N. (1989). *Relationship disturbances in early childhood. A developmental approach*. New York: Basic Books.

Stern, Daniel N. (1985). *The interpersonal world of the infant. A view from psychoanalysis and developmental psychology*. New York: Basic Books.

Stevenson-Hinde, J., and Simpson, M. J. A. (1981). Mothers' characteristics, interactions, and infants' characteristics. *Child Development*, 52, 1246–1254.

---

## **ECKSTEIN, EMMA (1865–1924)**

Between 1892 and 1893 Emma Eckstein was one Sigmund Freud's most important patients and, for a short period of time around 1897, became a psychoanalyst herself. She was born on January 28, 1865, in Vienna and died on July 30, 1924. Eckstein belonged to a family that the Freuds were friendly with. One of her brothers, Frederick, was a Sanskrit specialist; another, Gustav, was a leading member of Karl Kautsky's Austrian socialist party. Aside from some cryptic passages concerning her (1937c), Freud never published her case history. In his *Project for a Scientific Psychology* (1895), Freud presented her phobia of stores in the chapter "Hysterical Proton Pseudos," but the manuscript was never published during Freud's lifetime.

In early 1895, finding that analysis could not eliminate Eckstein's compulsion for masturbation, which resulted in dysmenorrhea and stomach pains, Freud turned to Wilhelm Fliess for help. Fliess, basing his thinking on his theory of a "nasal reflex neurosis," operated on her nasal concha but left fifty centimeters of gauze inside her nose. The error was repaired by Professor Rozanes in Vienna, but Fliess felt he had been wronged because Freud had called in another physician to attend to Eckstein's problem. Freud attributed the accident to Eckstein's hysteria (1985, letter 56 et seq.), but she remained disfigured. Freud resumed his analysis of her and provided some improvement, and this motivated her to become a psychoanalyst in 1897. In December Eckstein confirmed that she had been seduced by her father (1985, letter 150), which Freud had doubted as late as September of that year.

Freud continued his relationship with Eckstein. He was furious to learn that Eckstein, during an operation for a myoma, had undergone a hysterectomy. He refused to resume analysis in November 1905. Meanwhile, Eckstein had published a small book on the sexual education of children (1904), in which she does not mention Freud. She seems to return to a theory of ancillary seduction, and she viewed infantile sexuality from a constitutional point of view: sucking and masturbation. From this time on a relapse forced her to take to her bed, where she remained until her death nineteen years later.

BERTRAND VICHYN

*See also:* Irma's injection, dream of.

### **Bibliography**

Anzieu, Didier. (1986). *Freud's Self-Analysis* (Peter Graham, Trans.). London: Hogarth Press and the Institute of Psycho-analysis.

Eckstein, Emma. (1904). *Die Sexualfrage in der Erziehung des Kindes*. Leipzig, Germany: Modernes Verlagsbureau, Curt Wigand.

Freud, Sigmund. (1895). Project for a scientific psychology. *SE*, 1: 281–387.

———. (1937c). Analysis terminable and interminable. *SE*, 23: 209–253.

———. (1985). *The complete letters of Sigmund Freud to Wilhelm Fliess, 1887–1904* (Jeffrey Moussaieff Masson, Trans.). Cambridge, MA: Belknap/Harvard University Press.

———. (1987). *A phylogenetic fantasy: Overview of the transference neuroses* (Axel Hoffer and Peter T. Hoffer, Trans.). Cambridge, MA: Harvard University Press.

Masson, Jeffrey Moussaieff. (1984). *The assault on truth*. New York: Farrar, Straus, and Giroux.

Schur, Max. (1972). *Freud: Living and dying*. New York: International Universities Press.

## **ÉCOLE DE LA CAUSE FREUDIENNE**

After the failure of the negotiations between the Société française de psychanalyse (French Society for Psychoanalysis) and the International Psychoanalytical Association over whether to recognize Jacques Lacan as a training analyst, two groups were founded. One was the Association psychanalytique de France

(French Psychoanalytic Association), which was founded on May 26, 1964, and became a member of the International Psychoanalytical Association even though it included a number of Lacanians. The other was the École française de psychanalyse (French School of Psychoanalysis), founded by Jacques Lacan on June 21, 1964. The school was renamed the École freudienne de Paris (Freudian School of Paris) when its bylaws were filed with the police on September 24 of the same year. Lacan dissolved this school by a letter dated January 5, 1980, though its legal dissolution was not voted on until September 27, 1980.

Then on February 21, 1980, with his “letter to the thousand,” which was a call to follow him, Lacan founded the Freudian cause, which he entrusted to Solange Faladé, Charles Melman, and Jacques-Alain Miller to direct. Following much discord and many departures, including the resignations of Faladé and Melman, Lacan established, as his base, the École de la Cause freudienne (ECF, School of the Freudian Cause). Its statutes were modified on September 24, 1993.

The ECF is the largest and most important Lacanian association in France. It has international connections with a number of other schools through the Association mondiale de la psychanalyse (World Association of Psychoanalysis), founded in Paris in 1992. The ECF is represented by Jacques-Alain Miller, Lacan's son-in-law and literary executor, and is led by a directorate of five members (who serve terms of two years and are responsible for its administration) and a council (which guides its orientation). The school has two levels of membership: member analyst of the school, a permanent title, and analyst of the school, a temporary title. These titles are holdovers from the old École Freudienne de Paris. Also, a practicing analyst can declare his or her practice within the school without the school certifying it.

The Association de la Cause freudienne (Association of the Freudian Cause) was founded on November 1, 1992, to gather the fifteen regional associations of the ECF, most of which publish a journal or bulletin. Through the Association mondiale de la psychanalyse and the Association de la fondation du champ freudienne (Association for the Foundation of the Freudian Field), founded by Lacan in 1979 and directed by his daughter Judith Miller, the Lacanian movement has an official presence in twenty-six foreign countries (and an especially important presence in

Latin America). Two organizations have split off from the ECF: the École de psychanalyse Sigmund Freud (The Sigmund Freud School of Psychoanalysis), which was founded in May 1994 and which revived the experiment of the pass (See Daniel Lagache, “On the Experiment of the Pass” [1973]), and the Forums du champ lacanien (Forums of the Lacanian Field), which was founded in May 1999 by three former presidents of the ECF.

The ECF publishes a semiannual journal, *Cause freudienne*, and a monthly newsletter.

JACQUES SÉDAT

*See also:* École Freudienne de Paris (Freudian School of Paris); France; Lacan, Jacques-Marie Émile; Movement lacanien français.

## ÉCOLE EXPÉRIMENTALE DE BONNEUIL

The École expérimentale de Bonneuil (Experimental school of Bonneuil) was founded on September 12, 1969 under the leadership of Maud Mannoni.

In his seminar, Jacques Lacan had asked analysts to take a somewhat closer interest in what went on in hospitals, in the belief that analytic discourse could be used to subvert the workings of these structures. In this context, Maud Mannoni began an institutional experiment at the Institut médico-pédagogique (Medical training institute) in Thiais, France. This experiment enabled her to produce *Le Psychiatre, son “fou” et la psychanalyse* (The psychiatrist, his “madman” and psychoanalysis; 1970), exposing the ways in which psychoanalysis betrays its vocation by participating in the institutional order. Her earlier works were *The Backward Child and His Mother: A Psychoanalytic Study* (1964/1972), in which she showed that in seeking to treat the symptom the patient’s needs were denied, and *The Child, His “Illness,” and the Others* (1967/1970), where she showed that the vision of the “sick person” is warped by one’s preconceptions.

Mannoni’s encounter with the anti-psychiatrists confirmed her ideas: They, too, were rebelling against any ideology based on “managing” madness, and were returning to Sigmund Freud’s suggestion that for the patient, delusions are an attempt at reconstruction. This break with medical thinking occasioned a focus on the idea of segregation that was operative in the

traditional psychoanalytic institution and entailed grouping patients into broad categories in psychiatric clinical work.

This principle of nonsegregation that presided over the opening of the Bonneuil facility was made concrete in its ideal mode of operation: One third of the children were autistic or psychotic children, one third were mentally deficient or emotionally disturbed, and one third were suffering from neuroses of varying degrees of severity. This mode of operation made it possible to maintain a mix of symptomatology that opened up dynamic perspectives, underscoring by this very fact the negative consequences of segregation for the subject, even when segregation was given a new guise and sanctioned by medicine under the name “mental illness.” That term implies as an alternative a hypothetical “mental health,” which has no place in a psychoanalytic perspective. The fundamental notion of “breaking out” is situated within this ethos of nonsegregation.

A place that is open to the outside rather than a self-enclosed institution cut off from the world (an organism created by normative forces acting against the emergence of foreclosed alternatives, to whose detriment this normativity has been maintained), the École expérimentale de Bonneuil was accredited as an outpatient hospital with nighttime intake facilities on March 17, 1975, with a capacity of twenty-six children, ages six to eighteen. Daily practice at Bonneuil is based on a psychoanalytic approach. Theory allows for the work of retrospective interpretation that examines individual pathways and institutional avatars. This constant back-and-forth movement between theory and praxis—in particular in the numerous work groups—characterizes the analyst’s place in the institution. That place is thus a paradoxical one: Practice is not what establishes analysts in their role, but it is what determines their specific place in this setting and the journey they will make with these troubled children. Cooking, running errands, working alongside artisans or farmers, completing schoolwork, and taking workshops—these activities are seen as so many mediations that make it possible to escape from an imaginary situation in which relations between adult and child are built without reference to any third party. The other possibility created is that the children can become the agents in a story that at some point converges with their own. What makes this legible is the putting into place of a framework, not in the sense of institutional rules, but rather a structure that

provides a sense of bearings and facilitates questioning, to guarantee that work will be ongoing. On March 12, 1980, an experimental family placement service was established for patients from eighteen to twenty-five years old. Since September 1, 1995, family placement has existed for patients older than twenty-five.

MICHEL POLO

*See also:* Infantile psychosis; Infantile schizophrenia; Mannoni-Van der Spoel, Maud; Technique with children, psychoanalytic.

### **Bibliography**

Mannoni, Maud. (1972). *The backward child and his mother: a psychoanalytic study*. (A. M. Sheridan Smith, Trans.). New York: Pantheon Books. (Original work published 1964)

———. (1970). *The child, his “illness,” and the others*. New York: Pantheon Books. (Original work published 1967)

———. (1970). *Le psychiatre, son “fou” et la psychanalyse*. Paris: Seuil.

---

## **ÉCOLE FREUDIENNE DE PARIS (FREUDIAN SCHOOL OF PARIS)**

On June 21, 1964, Jacques Lacan founded the *École française de psychanalyse* (EFP, French School of Psychoanalysis), which, without changing its initials, was quickly renamed the *École freudienne de Paris* (Freudian School of Paris). The meeting to found the new school was held in the home of François Perrier, the same place where the Quatrième Groupe (the Fourth Group, an offshoot of the EFP) would be founded in 1969. The gathering was attended by about fifty members of the *Société française de psychanalyse* (SFP, French Psychoanalytic Society), which would not formally be dissolved until January 1965. Lacan chose the word “school” in reference to the ancient schools of philosophy: “certain places of refuge, indeed bases of operation against what might already be called the discontents of civilization” (Lacan, 1964/1990, p. 104). The School’s “Founding Act” was completely different from that of any other psychoanalytic institution. Lacan announced the School’s project in a solemn tone: Its task would be “a labor which, in the field opened up by Freud, restores the cutting edge of his discovery” (p. 97). In order to do this, he made new distinctions in the field of psychoanalysis by creating three divisions, the direction of which he personally

undertook: the division for “pure psychoanalysis . . . which is and is nothing but . . . the training analysis” (p. 98), the division for “applied psychoanalysis, which means therapeutic and clinical medicine” (p. 99), and the division for “taking inventory of the Freudian field,” which would “undertake to publish those principles from which analytic practice is to receive its [scientific status]” (p. 99). Such a distinction between pure and didactic psychoanalysis on the one hand and the therapeutic field on the other could logically only lead to a recourse to science in order to legitimize psychoanalysis. Thus in the “Founding Act” the idealization of science that would later lead to the *mathème* was already on the horizon. It had already led Lacan in 1955 to imagine the “recognition of psychoanalysis, as either a profession or a science” on the basis of a “principle” (Lacan, 1966, p. 325).

The School recognized three categories of members, which did not in any way correspond to the traditional forms of membership in a psychoanalytic society. The rank of Analyst of the School (AE) was initially held by those who had been full members of the SFP, their task was the “doctrinal elaboration of training analysis.” To become an AE, one had to make a request to the “jury of approval.” The Analyst Member of the School (AME) were directly named, without a personal solicitation, by a “jury of reception” that guaranteed their “professional ability” based on the “approval of their training analyst, the advice of their supervisor or supervisors, and accounts of the candidate’s practice.” It was specified that, “in regard to the psychoanalytic treatments undertaken under his or her direction, the analyst is only authorized by him- or herself” (*Annuaire EFP* 1977). This sentence contributed to serious misunderstandings when its second half was taken to be a formula by which one could become an analyst, while in context it is clear that it is only a matter of being authorized in the session. The third category is that of the practicing analyst (A.P.), who declared their practice to the EFP without being sanctioned by it. Finally, it was also possible to be a member of the School without being an analyst by participating in its work and research.

The first board of directors that led the EFP was made up of Piera Aulagnier, Jean Clavreul, Jacques Lacan, Serge Leclair, François Perrier, Guy Rosolato, and Jean-Paul Valabrega. Each of them left the board successively, and some of them left the School altogether, with the exception of Jean Clavreul, who was a

member of the last board of directors to be formed (1967), and Lacan, president of the 1967 board, with Solage Faladé as vice-president, Éric Laurent as secretary and administrator of cartels, Jacques-Alain Miller as administrator of cartels, Charles Melman and Christian Simatos—longtime secretary of the School—as administrators of teaching, Claude Conté and Irène Roublef as administrators of publication, and René Bailly as assistant treasurer.

The EFP was officially established as a non-profit organization when its first set of bylaws, which were very concise, were filed on September 24, 1964. The members of the corporate board were lay people, friends of Lacan's. In 1969, in an effort to have the School recognized as a state-approved agency, more detailed bylaws were filed by Solange Faladé, but in 1970, the Council of State turned down the School's application.

During its fifteen years of existence, the EFP went through a series of institutional crises over policies and theoretical issues. On December 1, 1965, François Perrier resigned from the board of directors over the question of training, and on March 31, 1967, he proposed the formation of a "college of analysts" focused on the clinic. Jacques Lacan responded with his "Proposition of October 9, 1967, on the Psychoanalyst of the School" in which he suggested his procedure of "the pass." This proposal led to the 1968 departure of Guy Rosolato, who rejoined the Psychoanalytic Association of France (AFP). The first split within the Lacanian movement itself soon followed, with the departures of Piera Aulagnier, François Perrier, and Jean-Paul Valabrega during discussions on the pass at the Lutetia Assizes during January 1969. They took with them about twenty members of the School.

The departures of such eminent members caused disruptions within the School. Bit by bit, a rift developed between the EFP and the Department of the Freudian Field at Vincennes, which was founded by Serge Leclair in 1968 and taken over by Jacques Lacan and Jacques-Alain Miller at the end of 1970. This rift led to an implied division between the EFP's clinical analysts and the young analysts at Vincennes, whose academic training in psychoanalysis set them apart. This younger group became the vehicle for the logical orientation of Lacan's later career, especially after the founding of the journal *Ornicar?* by Jacques-Alain Miller in 1975. The Deauville Assizes on the experiment of the pass, held in January 1978, gave ample evidence of the failure of what Lacan had hoped would be

the primary institutional procedure of the School. It was also at this time that Lacan began to suffer from serious neurological problems (progressive aphasia).

In the end, the EFP collapsed on legal grounds. An extraordinary general assembly convened on September 30, 1979, to expand the corporate board from seventeen to twenty-five members and to elect a new board. But on January 5, 1980, in a letter addressed to the members of the School and read at his seminar, Lacan announced the dissolution of the School. This letter prompted Michèle Montrelay and twenty-seven other members to file a lawsuit claiming irregularities in the September meeting. A provisional administrator was named by the Paris municipal court on January 25, 1980. In 1980, three extraordinary general assemblies met without attaining a statutory majority until finally, on September 27, the dissolution of the EFP was passed.

When it was founded in June 1964, the EFP included about 100 members. In January 1980, membership stood at more than 600, a number that testifies to the vitality of French Lacanianism in that era.

JACQUES SÉDAT

*See also:* École de la Cause freudienne; France; Italy; Lacan, Jacques-Marie Émile; Mouvement lacanien français; *Ornicar?*; Pass, the; Splits in psychoanalysis; Training analysis.

### Bibliography

- Dorgeuille, Claude. (1981). *La Seconde Mort de Jacques Lacan*. Paris: Actualité freudienne.
- Lacan, Jacques. (1966). *Écrits*. Paris: Seuil.
- . (1990). Founding act. In *Television: A challenge to the psychoanalytic establishment* (Joan Copjec, Ed.). New York: Norton. (Original work published 1964)
- . (1995). Proposition of 9 October 1967 on the Psychoanalyst of the School (Russell Grigg, Trans.). *Analysis*, 6, 1–13. (Original work published 1968)
- Roudinesco, Élisabeth. (1997). *Jacques Lacan* (Barbara Bray, Trans.). New York: Columbia University Press. (Original work published 1993)

---

## ECONOMIC POINT OF VIEW

Along with the topographical and dynamic points of view, the economic point of view is one of the three main axes of metapsychology. It deals with psychic

events in terms of the intensity of the forces that run through them and animate them.

This concept was present in Freud's early thinking and appears in his first metapsychological formulations. It then assumed increasing importance during the evolution of his theoretical thinking and his conception of psychopathology. It is based on the hypothesis, much criticized in recent times, that the mental apparatus is invested with forces that are specific to it (instincts) and which can vary in intensity, either "constitutionally", or as a result of reinforcements linked to the vicissitudes of development (particularly trauma). These primary forces can oppose each other, combine together, and form complex amalgamations and alliances with each other. The economic point of view is an attempt to describe this interplay of forces and the resulting intensities.

After 1920, the economic approach assumed increasing importance in Freud's thinking because of the clinical difficulties encountered in non-neurotic cases. The metapsychological notions that Freud then developed attributed a centrally determinant role to the economic point of view in the genesis and maintenance of pathological conditions and their different structures.

In the same way that the concept of instincts is criticized by certain psychoanalysts who prefer more contemporary concepts that focus on information, representation, or signifiers (Widlöcher, D., 1997), the economic point of view has also elicited certain theoretical reservations. However, it is difficult to see how to modify this aspect of metapsychology, which is directly linked to the question of instincts, without seriously jeopardizing the whole of the corpus. Moreover, clinical work makes us sensitive to variations in instinctual intensity and investment which would be difficult to explain without recourse to the economic point of view and the binding and unbinding of instincts.

RENÉ ROUSSILLON

*See also:* Cathexis; Discharge; Excitation; Fusion/defusion; Libido; Pleasure/unpleasure principle; Primary process/secondary process; Principle of consistency; "Project for a scientific psychology, A"; Protective shield, breaking through the; Psychic energy; Quantitative/qualitative; Repression; Sum of excitation; Trauma; Traumatic neurosis.

### Bibliography

- Freud, Sigmund. (1905d). Three essays on the theory of sexuality. *SE*, 7: 123-243.
- . (1915c). Instincts and their vicissitudes. *SE*, 14: 141-158;
- . (1920g). Beyond the pleasure principle. *SE*, 18: 1-64;
- Green, André. (1995). *La causalité psychique. Entre nature et culture*. Paris: Odile Jacob.
- Widlöcher, Daniel. (1997). *Les nouvelles cartes de la psychanalyse*. Paris: Odile Jacob.

### Further Reading

- Lustman, Seymour L. (1968). The economic point of view and defense. *Psychoanalytic Study of the Child*, 23, 189-203.
- Meissner, William W. (1995). The economic principle in psychoanalysis. *Psychoanalysis and Contemporary Thought*, 18, 197-292.

---

## ÉCRITS

Until the publication of his *Écrits* (Writings), Jacques Lacan's only published book was his doctoral thesis in medicine, *De la psychose paranoïaque dans ses rapports avec la personnalité* (*On paranoid psychosis in its relations with personality*; 1932), written from a psychiatric, rather than psychoanalytic, perspective.

In the 1960s Lacan was asked by several of his students and by his friend François Wahl, of the publishing house Seuil, to collect his writings in a single volume. The considerable success of *De l'interprétation, essai sur Freud* (*Freud and Philosophy: An Essay on Interpretation*), by Paul Ricœur, in 1965 and then that of *Les mots et les choses* (*The Order of Things*), by Michel Foucault, in 1966 prompted him to prepare a collection of his articles.

He omitted all his work from before the war, notably his article "La vie mentale" (Mental life; 1938) from volume eight of the *Encyclopédie française* (the alternate title of which, "The Family Complexes in the Formation of the Individual," only appeared on the cover of an off-print). He did, however, make an exception for a text written in 1936 for Marienbad, where he delivered his lost lecture on the mirror stage to the congress of the International Psychoanalytic Association.

In the collection, he slightly modified his articles, often without any indication of the changes. He introduced the book with a recollection of his medical and psychiatric origins, “De nos antécédents” (On my antecedents), and preceded “Discours de Rome” (Rome discourse) of 1953 with a brief text that indicated the consequences of this discourse for the psychoanalysis of the future, “Du sujet enfin en question” (On the subject who is finally in question).

*Écrits* was published in the third trimester of 1966 by Seuil. The book very quickly achieved critical acclaim and was widely reviewed and debated in the press. It included a “Classified Index of the Major Concepts” by Jacques-Alain Miller. This index introduced a logical dimension to Lacanism that was emphasized from 1975 on. In the introduction to the index Miller wrote, “According to my conception of these *Écrits*, it is to our benefit to study them as forming a system. . . . For my own part, not needing to concern myself with the efficacy of the theory in [the clinic], I will encourage the reader by proposing that there is no outer limit to the expansion of formalization in the field of discourse” (pp. 358–359).

A measure of the influence of *Écrits* is that it has been translated in to numerous languages. Moreover, it was followed by a sequel, *Autres Écrits*, published in June 2001. In that volume Jacques-Alain Miller collected nearly all of Lacan’s articles from before 1939, such as “Les complexes familiaux dans la vie de l’individu” (Family complexes in the formation of the individual; 1938). Also included are the version of the “Discours de Rome” (Rome discourse) circulated in the proceedings of the IPA congress (1953) and all the texts that appeared after the publication of *Écrits* up to that of “L’étourdit” (Stunned; 1972), Lacan’s last published article.

JACQUES SÉDAT

See also: École freudienne de Paris (Freudian School of Paris); France; Lacan, Jacques-Marie Émile; Structuralism and psycho-analysis.

### Source Citation

Lacan, Jacques. (1966). *Écrits*. Paris: Le Seuil. *Schriften*. Olten, Switzerland: Walter-Verlag, 1973–1980. *Écrits: A Selection*. (Bruce Fink, Trans.). New York: Norton, 2004.

### Bibliography

- Dor, Joël. (1994). *Nouvelle bibliographie des travaux de Jacques Lacan*. Paris: Éditions et Publications de l’École Lacanienne.
- Lacan, Jacques. (1938). La vie mentale. *Encyclopédie française*, Vol. 8.
- . (1973). L’étourdit. *Scilicet*, 4, 5–52.
- . (2001). *Autres écrits* (Jacques-Alain Miller, Ed.). Paris: Éditions du Seuil.
- Roudinesco, Elisabeth. (1990). *Jacques Lacan & Co.: A History of Psychoanalysis in France, 1925–1985* (Jeffrey Mehlman, Trans.). Chicago: University of Chicago Press.

### EDER, DAVID MONTAGUE (1866–1936)

David Montague Eder, an English psychoanalyst, was born in August 1866 in London, where he died on March 30, 1936. He studied medicine in London, opened a practice as a general practitioner and, with Clara Grant, started the first school clinic as a result of his interest in education. He met Ernest Jones in 1904, but it was his enthusiasm that stemmed from his reading “Little Hans” in 1909 that led him to psychoanalysis. In 1911 he gave the first psychoanalytic conference in Great Britain, which scandalized members of the British Medical Association. After becoming an analyst in 1912, he met Jung and translated two of his works into English: *Diagnostische Assoziationsstudien* (Diagnostic Association Studies) and *Versuch einer Darstellung der psychoanalytischen Theorie* (The Theory of Psychoanalysis). In 1913 he traveled to Vienna to be analyzed by Freud, who sent him to Viktor Tausk. Eder was successively analyzed by Tausk, by Jones, and, after an attempt with Karl Abraham, by Sándor Ferenczi, with whom he shared the illusion of the “perfectly analyzed analyst.” Eder also introduced the work of Alfred Binet and Théodore Simon in Great Britain.

Eder was involved in a number of political and social issues. He argued against the unfairness of the Mental Deficiency Bill. Associated with Zionist literary and political circles through his Jewish family (he was a cousin of the writer Israel Zangwill and a friend of D. H. Lawrence; his wife, Edith, was the sister of the analyst Barbara Low), he embraced the Zionist cause.

In 1915 Eder joined the army as a doctor and was stationed in Malta, then at a neurological clinic in London. He published a book about his experiences entitled *War-shock* (1917), which focused on wartime neuroses

and their treatment. In 1920, while living in Palestine, he worked with Chaim Weizmann, Israel's first president, and led seminars in analysis (with Dorian Faigenbaum). This represented the first appearance of analysis in Israel prior to the arrival of Max Eitingon. He later became an elected representative of the Zionist Executive in Palestine and served from 1921 to 1927.

Eder distanced himself from Jung's ideas. In 1923 he joined the British Psychoanalytic Society, where he held numerous positions: first as secretary, then as director of the Institute of Psychoanalysis and director of the London Clinic of Psychoanalysis. In 1932 he was elected president of the medical section of the British Psychological Society.

He was the first to use psychoanalysis to treat a case of stuttering, which is described in "Das Stottern eine Psychoneurose und seine Behandlung durch die Psychoanalyse" (Stuttering: a psychoneurosis and its treatment through psychoanalysis; 1913). His theoretical works comprise some thirty articles, covering subjects that include dreams and resistance (1930), the psychological problems of eugenics and birth control, the economy and future of the superego (1929), the father's animosity toward the son, and Jewish rituals (1933).

This "political pugilist" and "liberator by vocation" (as Edward Glover described him) was also a passionate advocate of psychoanalysis, which he introduced into schools and prisons. Sigmund Freud confided to Barbara Low that he represented "a rare blend of intrepid courage and an absolute love of truth, together with tolerance and a great capacity to love."

MICHELLE MOREAU RICAUD

See also: Great Britain; Israel; Low, Barbara

### Bibliography

Eder, David. (1913). Das Stottern: eine Psychoneurose und seine Behandlung durch die Psychoanalyse. *Internationale Zeitschrift für ärztliche Psychoanalyse*, 1.

———. (1917). *War shock*. London: W. Heineman.

———. (1929). On the economics and the future of the super-ego. *International Journal of Psycho-analysis*, 10, 249–255.

———. (1930). Dreams—as resistance. *International Journal of Psycho-analysis*, 11, 40–47.

———. (1933). The Jewish phylacteries and other Jewish ritual observances. *International Journal of Psycho-analysis*, 14, 341–375.

Glover, Edward. (1945). Eder as a psychoanalyst. In Joseph Burton Hobman (Ed.), *David Eder: Memoirs of a modern pioneer*. London: Victor Gollancz.

Hobman, Joseph Burton (Ed.). (1945). *David Eder: Memoirs of a modern pioneer*. London: Victor Gollancz.

## EGO

The notion of *das Ich* (literally "the I") was present in Freud's thought from the earliest days of psychoanalysis, but over the years it underwent serious theoretical modifications, often connected to advances in clinical practice. The term had long designated the self-conscious person as a whole, but in 1923 Freud assigned it the role of an agency of the mental apparatus with a mediating and regulatory function vis-à-vis the id, the superego, and external reality. He would always, however, allow a measure of ambiguity to persist with respect to the two meanings, and it was only after his death that they were disentangled and promoted separately in contradistinction to one another. With the stress placed by the proponents of ego psychology on the ego's adaptative functions, the notion tended to be upstaged by the "self," the "I," or the "subject."

To begin with, then, Freud tended to employ "*das Ich*" in a sense akin to that of the philosophers, that is to say as a synonym for "conscious person." Only later did he reserve the term for a portion of the mental personality, in accordance with his constant concern to distinguish analysis from synthesis. But the German word remained ambiguous, along with its use in Freud's writing, and its translation into other languages inevitably occasioned problems and debates. The choice of "ego" by the translators of the *Standard Edition* has been challenged, by Bruno Bettelheim among others: "To mistranslate *Ich* as 'ego' is to transform it into jargon that no longer conveys the personal commitment we make when we say 'I' or 'me'" (Bettelheim, p. 53). As for the early French psychoanalysts, they hesitated between "ego" and "*le Moi*" before plumping for this last term in preference to either "ego" or "*Je*."

Very early on in his thinking, contemporary research on "split personality," that is to say, on the dissociation of consciousness, along with his own use of hypnosis, led Freud to place the ego qua consciousness in the position of an active judge in the conflicts underlying psychopathological symptoms. In his article on "The Neuro-Psychoses of Defence" (1894a), he



emphasized the “task which the ego, in its defensive attitude, sets itself of treating the incompatible idea as ‘*non arrivée*’” (p. 48). The following year, he described the ego at length in biological terms, in the “Project for a Scientific Psychology,” (1950a [1895]), as a group of neurones designed to control primary processes and avoid unpleasure: “the ego is to be defined as the totality of the psi cathexes at the given time” (p. 323). As thus characterized, the ego was no longer synonymous with the whole person: Its future role as a psychical agency was foreshadowed, and it was already responsible for regulating energy flows, a task that would fall to it more and more clearly in the psychological context.

Freud’s “first topography,” founded on the distinctions between the Conscious, the Preconscious, and the Unconscious, made no essential appeal to the ego, which makes its appearance in *The Interpretation of Dreams* mainly as the bearer of the wish for sleep or else as a key actor at the center of the masquerade in which, as censor, it itself cloaks unconscious wishes: “Dreams are completely egoistic. Whenever my own ego does not appear in the content of the dream, but only some extraneous person, I may safely assume that my own ego lies concealed, by identification, behind this other person; I can insert my ego into the context. On other occasions, when my ego does appear in the dream, the situation in which it occurs may teach me that some other person lies concealed, by identification, behind my ego. In that case, the dream should warn me to transfer on to myself, when I am interpreting the dream, the concealed common element attached to this other person. There are also dreams in which my ego appears along with other people who, when the identification is resolved, are revealed once again as my ego. These identifications should then make it possible for me to bring into contact with my ego certain ideas whose acceptance has been forbidden by the censorship. Thus my ego may be represented in a dream several times over, now directly and now through identification with extraneous persons” (1900a, pp. 322–23). The “my ego” here stood for “the representation of myself” in the sense of identity. This early link made by Freud between the ego and processes of identification is noteworthy.

Over the next fifteen years Freud developed the notion, not so much in topographical terms, for in that sense the ego remained within the Preconscious-Conscious system, but in dynamic and economic

terms, especially with respect to its role in the regulation of pleasure/unpleasure. The notion of “ego instincts,” also known as “self-preservative instincts,” as distinct from the “sexual instincts,” was introduced by Freud as early as 1910; he observed that the two classes of instincts “have in general the same organs and systems of organs at their disposal” (1910i, pp. 215–16). Even if, not long before, he had ironized on “His Majesty the Ego, the hero alike of every day-dream and of every story” (1908e, p. 150), Freud now deemed external reality one of the constraints that the ego was obliged to confront. In “Formulations on the Two Principles of Mental Functioning,” he drew a distinction between a “pleasure ego,” related to the infant’s attempts to achieve a hallucinatory satisfaction of its wishes, and a “reality ego” developed over time in response to life’s failure to supply satisfaction: “Just as the pleasure-ego can do nothing but *wish*, work for a yield of pleasure, and avoid unpleasure, so the reality-ego need do nothing but strive for what is *useful* and guard itself against damage” (1911b, p. 223). The ego was thus being presented more and more as an essential working part in the regulation of a complex mental system.

In the same year of 1911, the problem of psychotic patients led Freud, stimulated in this regard by Jung’s research on the issue, to complete his first reflections on narcissism and identification, begun in his study of Leonardo da Vinci the year before. In his “Psycho-Analytic Notes on an Autobiographical Account of a Case of Paranoia,” he argued that dementias, especially schizophrenic dementia, should be seen as involving “the detachment of libido” from the external world and its “regression on to the ego” (p. 76), in memory of that time when “a person’s only sexual object [was] his own ego” (p. 72). In “The Claims of Psycho-Analysis to Scientific Interest,” he offered this summary of his view of the nature of the neuroses: “The primal conflict which leads to neuroses is one between the sexual instincts and those which maintain the ego. The neuroses represent a more or less partial overpowering of the ego by sexuality after the ego’s attempts at suppressing sexuality have failed” (1913j, p. 181).

Alfred Adler’s theories were doubtless not without their influence, too, on the questions Freud was asking himself at this time, even if he felt that Adler underestimated the importance of unconscious processes, and wrote to Jung on March 3, 1911: “I would never have expected a psychoanalyst to be so taken in by the ego.

In reality the ego is like the clown in the circus, who is always putting in his oar to make the audience think that whatever happens is his doing" (*Freud/Jung Letters*, p. 400). We know that Freud would modify this view later, but for now he kept the emphasis on the socius: "psycho-analysis has fully demonstrated the part played by social conditions and requirements in the causation of neurosis. The forces which, operating from the ego, bring about the restriction and repression of instinct owe their existence essentially to compliance with the demands of civilization" (1913j, p. 188).

In 1912 Freud could still describe the ego as synonymous with the mental personality as a whole, as he did in a letter to Ludwig Binswanger of July 4, 1912: "I have long suspected that not only the repressed but also the dominant aspect of our life, the essence of the ego, is unconscious though not inaccessible to the conscious" (1992 [1908-38], p. 90). But his paper "On Narcissism: An Introduction" (1914b) marked the turning-point which endowed the ego with a new significance in theory as in practice: "Thus we form the idea of there being an original libidinal cathexis of the ego, from which some is later given off to objects, but which fundamentally persists and is related to the object-cathexes much as the body of an amoeba is related to the pseudopodia which it puts out. . . . We see also, broadly speaking, an antithesis between ego-libido and object-libido" (pp. 75–76). Another observation of Freud's raised an issue which has never since ceased being debated, that of the genesis of the ego: "we are bound to suppose that a unity comparable to the ego cannot exist in the individual from the start; the ego has to be developed" (pp. 76–77). The distinction between ego instincts and sexual instincts was preserved, even if Freud stressed that "the hypothesis of separate ego-instincts and sexual instincts (that is to say, the libido theory) rests scarcely at all upon a psychological basis, but derives its principal support from biology" (p. 79). In this same text another idea too was introduced into the theory of analysis, that of the ideal ego against which the actual ego is measured: "Repression . . . proceeds from the self-respect of the ego. . . . This ideal ego [*Idealich*] is now the target of the self-love which was enjoyed in childhood by the actual ego. The subject's narcissism makes its appearance displaced on to this new ideal ego [*Dieses neue ideale Ich*] which, like the infantile ego, finds itself possessed of every perfection" (pp. 93–94). At the same time—and

this was what distanced Freud from the theories of Jung, who had just parted company with him—it was essential not to confuse "homage to a high ego ideal" with the sublimation of the libidinal instincts (p. 94). In the first case repression was reinforced, according to Freud, whereas in the second sublimated instinctual satisfaction made repression unnecessary. As for the "special psychical agency which performs the task of seeing that narcissistic satisfaction from the ego ideal is ensured and which, with this end in view, constantly watches the actual ego and measures it by that ideal" (p. 95), this was clearly the adumbration of the future superego.

In 1915 Freud added the following observation to the third edition of his *Three Essays on the Theory of Sexuality*: "In contrast to object-libido, we also describe ego-libido as 'narcissistic' libido. . . . Narcissistic or ego-libido seems to be the great reservoir from which the object-cathexes are sent out and into which they are withdrawn once more; the narcissistic libidinal cathexis of the ego is the original state of things, realized in earliest childhood, and is merely covered by the later extrusions of libido, but in essentials persists behind them" (1905d, p. 218). In this perspective, progression from auto-erotism to genital heterosexuality could include a moment characterized by a narcissistic or even a homosexual object-choice. In the *Introductory Lectures on Psycho-Analysis*, Freud went on to evoke a possible view of the ego's strength which was destined to have not a little influence on the post-Freudian theory of psychoanalytic technique: "A person only falls ill of a neurosis if his ego has lost the capacity to allocate his libido in some way. The stronger his ego, the easier will it be for it to carry out that task. Any weakening of his ego from whatever cause must have the same effect as an excessive increase in the claims of the libido and will thus make it possible for him to fall ill of a neurosis" (1916–17a [1915–17], p. 387). The suggestion that a weak ego needed "strengthening" gained considerable currency among analysts after the Second World War, along with the idea of the therapeutic alliance which it was felt should be achieved between the therapist and the healthy part of the patient's ego. Both Melanie Klein and Jacques Lacan, each in their own way, contested this approach.

During the 1915–1920 period, Freud's theory of the ego underwent many refinements as his metapsychological papers and summarizing lectures of introduction to psychoanalysis continued to synthesize his

thought. But it would be a mistake to overlook the fact that in a good number of his theoretical speculations the coexistence of old and new ideas was still quite possible, and that contradictions often appear if Freud's formulations are placed side by side. Thus in 1918, on the point of unveiling a completely new view of the ego, Freud could still write: "the neurotic patient presents us with a torn mind, divided by resistances. As we analyze it and remove the resistances, it grows together; the great unity which we call his ego fits into itself all the instinctual impulses which before had been split off and held apart from it. The psychosynthesis is thus achieved during analytic treatment without our intervention, automatically and inevitably. We have created the conditions for it by breaking up the symptoms into their elements and by removing the resistances" (1919a [1918], p. 161).

It would not be long, however, before the said "great unity" was dismantled. His reflections on schizophrenia led Freud to create the class of "narcissistic neuroses." Those on melancholia brought forth the category of "narcissistic identification," meaning the identification of the ego with a lost object: "Thus the shadow of the object fell upon the ego, and the latter could henceforth be judged by a special agency, as though it were an object, the forsaken object. In this way an object-loss was transformed into an ego-loss and the conflict between the ego and the loved person into a cleavage between the critical activity of the ego and the ego as transformed by identification" (1917e [1915], p. 249). It was from this time, too, that identification took on an ever greater significance in Freud's account of the ego's genesis and development. It was said, after all, to be the earliest mode of object-cathexis. And identification was invoked by Freud, in *Group Psychology and the Analysis of the Ego* (1921c), as the bond that structures all social organization.

*Beyond the Pleasure Principle*, however, was the text that contained the first hint of Freud's abandoning the psychical apparatus as described in 1900: "it is certain that much of the ego is itself unconscious, and notably what we may describe as its nucleus" (1920g, p. 19). Furthermore, the introduction of the death instinct in the same work rendered obsolete Freud's earlier distinction between ego instincts and sexual instincts, for both self-preservation and the relief of tension due to unpleasure now fell within the remit of a death instinct which the ego appeared to serve, whether in its inhibiting and repressive functions or in resistances, observed

during treatment, that were linked to the repetition compulsion.

Three years later, in *The Ego and the Id* (1923b), the ego finally achieved the status of an important agency in the description of the mental personality. The starting point of this work was the assertion that "A part of the ego, too—and Heaven knows how important a part—may be *Ucs.*, undoubtedly is *Ucs.*" (p. 18). The old account based on the *Cs./Pcs./Ucs.* schema was discarded, these substantives to be confined henceforward to a solely adjectival use denoting properties, but the processes described earlier to explain "coming to consciousness" remained valid: unconscious thing-presentations still had to be brought into connection with word-presentations in order to become conscious (see "The Unconscious" [1915e]). The ego was now described as wearing a "cap of hearing," the origin of perception and of the memory traces that perpetuated it.

*The Ego and the Id* views the ego primarily as a surface differentiation of the id under the influence of the external world; it conveys the demands of the external world to the instinctual agency of the id, with which it remains in permanent contact at its base. As a messenger of reality, the ego replaces the reign of the pleasure principle by that of the reality principle, imposing the constraints of the social environment. It is the agent of the repression (or the sublimation) of the instincts, of the censorship of dreams, and the cause of resistances to the treatment, and it manages object-cathexes and controls motility. All these responsibilities do not preclude a certain passivity of the ego. Recalling the tale of Itzig, who does not know where he is going, and says "Ask my horse!"; Freud writes: "Thus in its relation to the id it is like a man on horseback, who has to hold in check the superior strength of the horse; with this difference, that the rider tries to do so with his own strength while the ego uses borrowed forces. The analogy may be carried a little further. Often a rider, if he is not to be parted from his horse, is obliged to guide it where it wants to go; so in the same way the ego is in the habit of transforming the id's will into action as if it were its own" (p. 25).

But "The ego is first and foremost a bodily ego; it is not merely a surface entity, but is itself the projection of a surface" (p. 26). This idea was elaborated by Freud in a note added to the English translation of *The Ego and the Id* published in 1927: "the ego is ultimately derived from bodily sensations, chiefly from those

springing from the surface of the body. It may thus be regarded as a mental projection of the surface of the body, besides, as we have seen above, representing the superficialities of the mental apparatus" (p. 26n). (Here it is possible to discern the origins of the "skin-ego" described by Didier Anzieu in 1985 [Anzieu, 1989]). The ego derives energy from narcissistic libido, and in this connection Freud evokes the possibility of a libido (even an Eros) that is "desexualized" or "sublimated," "displaceable and neutral"—and, one can only suppose, not easily reconcilable with the theses of ego psychology on an autonomous and conflictless ego. At all events, according to Freud, "The narcissism of the ego is . . . a secondary one, which has been withdrawn from objects" (pp. 44–46).

The importance of processes of identification is much emphasized in *The Ego and the Id*. Identification is the basis of the earliest object-cathexes and retains this function first in the form of incorporation and later as identification proper. (As early as 1909 Sándor Ferenczi had described the growth of the ego in terms of introjection.) But the fate of object-cathexes is that they must be abandoned in the course of a person's history, and Freud concludes in this connection that the mechanism of melancholia is universally applicable. Thanks to narcissistic identification, the abandoned object is perpetuated within the ego, which seeks on this basis to make itself loved by the id: "I am so like the object" (p. 30). Freud is thus able to frame the following proposition, so often misread since: "It may be that this identification is the sole condition under which the id can give up its objects. At any rate the process, especially in the early phases of development, is a very frequent one, and it makes it possible to suppose that the character of the ego is a precipitate of abandoned object-cathexes and that it contains the history of those object-choices" (p. 29). As we shall see, the restriction here, that only the "character" of the ego and not the ego as a whole is involved in this process, would often be overlooked subsequently; all the same, Freud's evocation of the succession—even the contradictory coexistence—of object identifications in the case of "multiple personalities" (pp. 30–31) shows just how much the ego remains the seat of identifications for him.

We should note lastly in this context that the Other, as object, made its definitive entrance into psychoanalytic theory in *The Ego and the Id*, opening the way to the discussion of "object relations" that was to have a

greater and greater effect on practice in the future. And, along with the Other, the past, tradition, and intergenerational transmission, or in other words the ego's primal identifications with the two parents, which were also placed at the origin of the other agency described, the superego.

The distinction between individual and ego is nevertheless very clearly drawn: "We shall now look upon an individual as a psychological id, unknown and unconscious, upon whose surface rests the ego, developed from its nucleus the *Pcpt.* [perception-consciousness] system. If we make an effort to represent this pictorially, we may add that the ego does not completely envelop the id, but only does to the extent to which the system *Pcpt.* forms its [the ego's] surface, more or less as the germinal disc rests upon the ovum. The ego is not sharply separated from the id; its lower portion merges into it" (p. 24).

As we know, each of the hypotheses set forth in *The Ego and the Id* was subject to theoretical developments, often divergent ones, in later years. Freud himself never ceased working on them, as when, in "Neurosis and Psychosis," he offered a "simple formula. . . which deals with what is perhaps the most important genetic difference between a neurosis and a psychosis: *neurosis is the result of a conflict between the ego and its id, whereas psychosis is the analogous outcome of a similar disturbance between the ego and the external world*" (p. 149). Or when, in "The Economic Problem of Masochism," he clarified the point that "the function of the ego is to unite and to reconcile the claims of the three agencies which it serves; and we may add that in doing so it also possesses in the super-ego a model which it can strive to follow" (1924c, p. 167). Again, in "Negation," Freud recalled that "the original pleasure-ego wants to introject into itself everything that is good and to eject from itself everything that is bad. What is bad, what is alien to the ego and what is external are, to begin with, identical"; and also that "The other sort of decision made by the function of judgement—as to the real existence of something of which there is a presentation (reality-testing)—is a concern of the definitive reality-ego, which develops out of the initial pleasure-ego. It is now no longer a question of whether what has been perceived (a thing) shall be taken into the ego or not, but of whether something which is in the ego as a presentation can be rediscovered in perception (reality) as well" (1925h, p. 237).

In *Inhibitions, Symptoms and Anxiety*, Freud would underscore the ego's functions in the regulation of the instincts, giving back to the idea of "defense mechanisms" a place that had long been usurped by the notion of "repression." He also modified his theory of anxiety, assigning it a source in the ego, which, when confronted by danger, triggered anxiety as a signal and so mobilized defensive processes: "whereas I formerly believed that anxiety invariably arose automatically by an economic process, my present conception of anxiety as a signal given by the ego in order to affect the pleasure-unpleasure agency does away with the necessity of considering the economic factor." It was probable, Freud added, that "the earliest repressions as well as most of the later ones are motivated by an ego-anxiety of this sort in regard to particular processes in the id" (1926d [1925], p. 140).

The question of the ego was raised directly or indirectly, and new considerations on the subject were adduced, throughout Freud's later work. The notion of "disavowal" (1927e) and the study of perversions, even more than the descriptions in *Civilization and Its Discontents* (1930a [1929]) and *An Outline of Psycho-Analysis* (1940a [1938]), were what led Freud to his last great formulation concerning the ego—that on the "splitting of the ego": Faced by a conflict between the instinctual demand for masturbatory pleasure and the apprehension of the reality of the threat of castration, the child embraces two contradictory positions simultaneously, "at the price of a rift in the ego which never heals but which increases as time goes on. The two contrary reactions to the conflict persist as the centre-point of a splitting of the ego. The whole process seems so strange to us because we take for granted the synthetic nature of the processes of the ego. But we are clearly at fault in this. The synthetic function of the ego, though it is of such extraordinary importance, is subject to particular conditions and is liable to a whole number of disturbances" (1940e [1938], p. 276).

On the clinical plane, the ego's role was defined by Freud in the conclusion to the twenty-third of the *New Introductory Lectures*—a passage that has caused a very great deal of ink to flow, especially in France. The "therapeutic efforts of psycho-analysis," Freud writes, are "to strengthen the ego, to make it more independent of the super-ego, to widen its field of perception and enlarge its organization, so that it can appropriate fresh portions of the id. Where id was, there ego shall be. It is a work of culture—not unlike the draining of

the Zuider Zee" (1933a [1932], p. 80). Freud returned to the matter in "Analysis Terminable and Interminable": "As is well known, the analytic situation consists in our allying ourselves with the ego of the person under treatment, in order to subdue portions of his id which are uncontrolled—that is to say to include them in the synthesis of his ego. The fact that a co-operation of this kind habitually fails in the case of psychotics affords us a first solid footing for our judgement. The ego, if we are to be able to make such a pact with it, must be a normal one. But a normal ego of this sort is, like normality in general, an ideal fiction. The abnormal ego, which is unserviceable for our purposes, is unfortunately no fiction. Every normal person, in fact, is only normal on the average. His ego approximates to that of the psychotic in some part or other and to a greater or lesser extent; and the degree of its remoteness from one end of the series and of its proximity to the other will furnish us with a provisional measure of what we have so indefinitely termed an 'alteration of the ego'" (1937c, p. 235).

Anna Freud, in *The Ego and the Mechanisms of Defence*, published in 1936, was the first to revisit and round out her father's hypotheses. This was the start of a series of studies by Anna Freud centered on the psychology of the ego, sometimes to the detriment of the interpretation of unconscious fantasies. In 1939, Heinz Hartmann laid the groundwork of what the psychoanalytical migration to the United States would develop into ego psychology thanks to the work of Ernst Kris, Rudolph Loewenstein, David Rapaport, Paul Federn, and so many others. So influential was ego psychology that for a time this theoretical orientation appeared to constitute the most thoroughgoing expression of Freudian orthodoxy.

In point of fact, Hartmann's idea of the "autonomy" of the ego, which he proposed as early as 1939, was in contradiction with Freud's views on the origins of this mental agency, which for him could never be anything but conflicted, bound up as it was with the relations between instinctual demands and the requirements of external reality. According to Hartmann, certain functions of the ego developed independently of the id and were essentially in the service of the individual's adaptation to the environment; the socialization factor was also underlined by Erik Erikson (1950). The notion of "primary narcissism" and that of a gradual development of the ego and its object relationships then became the subject of lively debate, notably with the Kleinian analysts.

For Melanie Klein, the ego and its object relationships existed from birth, as witness the early split between good and bad objects or the mechanisms of projection and projective identification, which manifested themselves right away. Klein's use of the term "self" should also be noted; her students and followers called upon it more and more, feeling that it helped distance them from the over-"mechanistic" account of the ego put forward by the American school. Things were not so simple, however, for the Americans too adopted the idea of a self—Heinz Kohut even invented a "self psychology"—and some of them sought to give identity priority over the haze in which Freud had ultimately left the definition of the ego as distinct from the notion of the person. In a parallel development, the stress placed on "object relationships" by Anglo-Saxon authors (W. R. D. Fairbairn, Margaret Mahler, Otto Kernberg) or French ones (Maurice Bouvet) shifted theoretical and above all clinical interest away from the state of an ego in need of cure and onto the vicissitudes of the pregenital and genital relations established by a subject who repeated these in the transference.

In France, there was no sarcasm too biting for Jacques Lacan when it came to the proponents of ego psychology, and he based himself on his theory of organization by language to place the ego resolutely in the realm of the Imaginary. His notion of the "mirror phase," first proposed in 1936, was intended to account for the constitution, by means of specular identification, not of the ego but rather of an "I" which foreshadowed the significance assumed later in his theory by the "subject" (Lacan, 1977 [1949]). He nonetheless devoted his 1954–55 Seminar to "The Ego in Freud's Theory and in the Technique of Psychoanalysis" (Lacan, 1993 [1981]). Piera Aulagnier, for her part, abandoned the notion of the ego in favor of a concept of the "I" different from Lacan's.

Present-day psychoanalysis is clearly more interested in synthetic approaches to the individual and the individual's relationship to others than in the ego as the frontier agency to which Freud accorded so much importance, as described above. No doubt the considerable extension of the psychoanalytic approach to psychotic patients has contributed to this tendency to globalize the person and be less attentive to an ego conceived as "weak" or "in pieces." There can be no doubt, either, that the emphasis placed on the adaptive functions of the ego has in the eyes of many amounted

to a bastardization of psychoanalysis favoring more and more "psychotherapeutic" or even political goals, and thus running counter to the liberation that Freud's discoveries imply. At all events, it is vital to keep in mind what clinical and therapeutic issues underlie and determine such theoretical divergences, namely adaptation to reality, the interpretation of unconscious fantasies, social adjustment, autonomy/disalienation, and so on.

ALAIN DE MIJOLLA

*See also:* Binding/unbinding of the instincts; Cathectic energy; Defense mechanisms; Depersonalization; *Ego and the Id, The; Ego and the Mechanisms of Defence, The*; Ego alterations; Ego (analytical psychology); Ego autonomy; Ego boundaries; Ego (ego psychology); Ego feeling; Ego functions; Ego ideal; Ego ideal/ideal ego; Ego-instinct; Ego interests; Ego-libido/object-libido; *Ego Psychology and Psychosis*; Ego psychology; *Ego Psychology and the Problem of Adaptation*; Ego-syntonic; Federn, Paul; *Group Psychology and the Analysis of the Ego*; Hartmann, Heinz; I; Id; Identification; Identity; Infantile omnipotence; Kris, Ernst; Loewenstein, Rudolph M.; Megalomania; Narcissism; *New Introductory Lectures on Psychoanalysis*; "On Narcissism: An Introduction"; *Outline of Psychoanalysis, An*; Passion; Perception-consciousness (Pcpt.-Cs.); Pleasure ego/reality ego; Primary identification; ; Psychoanalytic treatment; Purified-pleasure-ego; Structuralism and psychoanalysis; Self (analytical psychology); Self-hatred; Self-image; Self-preservation; Skin-ego; "Splitting of the Ego in the Process of Defence, The"; Superego; Therapeutic alliance; Tube-ego.

### **Bibliography**

- Anzieu, Didier. (1989 [1985]). *The skin ego*. New Haven and London: Yale University Press.
- Bettelheim, Bruno. (1983). *Freud and man's soul*. New York: Knopf.
- Erikson, Erik H. (1950). *Childhood and society*. New York: Norton.
- Freud, Anna. *The ego and the mechanisms of defence*. (1937 [1936]). London: Hogarth.
- Freud, Sigmund. (1894a). The neuro-psychoses of defence. *SE*, 3.
- . (1900a). The interpretation of dreams. *SE*, 4–5.
- . (1905d). Three essays on the theory of sexuality. *SE*, 7.
- . (1908e). Creative writers and day-dreaming. *SE*, 12.

- . (1910i). The psycho-analytic view of psychogenic disturbances of vision. *SE*, 11.
- . (1911b). Formulations on the two principles of mental functioning. *SE*, 12.
- . (1911c). Psycho-analytic notes on an autobiographical account of a case of paranoia. (Dementia paranoides). *SE*, 12.
- . (1913j). The claims of psycho-analysis to scientific interest. *SE*, 13.
- . (1914b). On narcissism: An introduction. *SE*, 14.
- . (1915e). The unconscious. *SE*, 14.
- . (1916–17a [1915–17]). Introductory lectures on psycho-analysis. *SE*, 15–16.
- . (1917e [1915]). Mourning and melancholia. *SE*, 14.
- . (1919a [1918]). Lines of advance in psycho-analytic therapy. *SE*, 17.
- . (1920g). Beyond the pleasure principle. *SE*, 18.
- . (1921c). Group psychology and the analysis of the ego. *SE*, 18.
- . (1923b). The ego and the id. *SE*, 19.
- . (1924b). Neurosis and psychosis. *SE*, 19.
- . (1924c). The economic problem of masochism. *SE*, 19.
- . (1925h). Negation. *SE*, 19.
- . (1926d [1925]). Inhibitions, symptoms and anxiety. *SE*, 20.
- . (1927e). Fetishism. *SE*, 21.
- . (1930a [1929]). Civilization and its discontents. *SE*, 21.
- . (1933a [1932]). New introductory lectures on psycho-analysis. *SE*, 22.
- . (1937c). Analysis terminable and interminable. *SE*, 23.
- . (1940a [1938]). An outline of psycho-analysis. *SE*, 23.
- . (1940e [1938]). Splitting of the ego in the process of defence. *SE*, 23.
- . (1950a [1895]). Project for a scientific psychology. *SE*, 1.
- Freud, Sigmund, and Jung, Car. (1974a [1906–13]). *The Freud/Jung letters* (William McGuire, Ed.; Ralph Manheim and R. F. C. Hull, Trans.). Princeton, NJ: Princeton University Press.

Freud, Sigmund, and Ludwig Binswanger. (1992 [1908–38]). *The Sigmund Freud-Ludwig Binswanger correspondence* (Gerhard Fichtner, Ed.; Arnold J. Pomerans, Trans.). New York: Other Press, 2003.

Hartmann, Heinz. (1939). *Essays on ego psychology*. New York: International Universities Press, 1964.

Lacan, Jacques. (1993). *The ego in Freud's theory and in the technique of psychoanalysis: 1954–1955*. (Sylvana Tomaselli, Trans.). New York: Norton. (Original work published 1981)

Lacan, Jacques. (2004). The mirror stage as formative of the function of the i. In *Écrits: A Selection* (Bruce Fink, Trans.). New York: W. W. Norton. (Original work published 1949)

### Further Reading

Busch, Fred. (1995). *The ego at the center of clinical technique*. Northvale, NJ: Aronson Inc.

Gray, Paul. (1994). *The ego and the analysis of defense*. Northvale, NJ: Aronson Inc.

Marcus, Eric. (1999). Modern ego psychology. *Journal of the American Psychoanalytic Association*, 47, 843–872.

Opatow, Barry. (1993). On the drive-rootedness of psychoanalytic ego psychology. *International Journal of Psychoanalysis*, 74, 437–458.

Orgel, Shelley. (1995). K. R. Eissler's "Effect of structure ego on analytic technique.". *Psychoanalytic Quarterly*, 64, 551–570.

Pine, Fred. (1990). *Drive, ego, object, and self*. New York: Basic Books.

Wallerstein, Robert. (2002). The growth and transformation of American ego psychology. *Journal of the American Psychoanalytic Association*, 50, 135–170.

## EGO, ALTERATION OF THE

The term “alteration of the ego” refers to changes that the ego undergoes as a function of age or as a result of neurotic or psychotic injuries with which it must deal.

This idea was evoked several times in Freud's work. Though it was referred to in “On Narcissism: An Introduction” (1914c), the mention was brief, for Freud had not as yet taken up the ego as an object of investigation. This was during the period when he went so far as to compare the ego to “a clown in the circus” (1914d, p. 53). Once the important part played by the ego in the unconscious was recognized, the function of defense took on great significance as the origin of alterations of the ego (1937c).

Later, with the advent of ego psychology, whether that of Heinz Hartmann or that of Paul Federn, the concept of “alteration of the ego” came fully into its own. In the first place, these changes were seen to constitute a continual mental process, extending from the primordial form of sucking at the breast to the most complex forms of scientific thinking. This process may be observed most clearly at turning points in life, as for example during the transition from childhood to adolescence or from adolescence to adulthood. Similarly, even though the change is far slower and more subtle, there is certainly a difference between the ego of the adult and that of the individual in old age.

On another level, the ego can be modified as a consequence of neurotic or psychotic disturbances. In the case of neurosis, the mechanisms of defense become so significant that the ego is obliged to transform itself, even though such transformation is never so far-reaching as it is when a psychotic process comes into play. The critical difference between these two kinds of alteration is that in neurosis there is no apparent splitting of the ego, whereas in the case of psychosis such splitting is evident. A split ego, obviously, is an altered ego. In a highly cathected narcissistic ego, transformations are harder to observe, save perhaps a certain behavioral rigidity. It is when the ego collapses under strong pressures that alterations occur. Alterations of the ego, it should be noted, are an aspect of the normal psychology, as well as of the pathology, of the ego.

ERNST FEDERN

*See also:* Ego; Ego psychology.

### **Bibliography**

- Anzieu, Didier. (1986). Some alterations of the ego which make analyses interminable. *International Journal of Psycho-Analysis*, 68, 9–19.
- Freud, Sigmund. (1914c). On narcissism: An introduction. *SE*, 14: 67–102.
- . (1914d). On the history of the psycho-analytic movement. *SE*, 14: 1–66.
- . (1937c). Analysis terminable and interminable. *SE*, 23: 209–253.

## **EGO (ANALYTICAL PSYCHOLOGY)**

Carl Gustav Jung proposed the following definition of the ego: “By ego I understand a complex of ideas

which constitutes the centre of my field of consciousness and appears to possess a high degree of continuity and identity. Hence I also speak of an *ego-complex*” (Jung, 1921, p. 425).

Jung actually conceives the ego-complex (or complex of the ego; *Ichkomplex*) as both a content and a condition of consciousness, which is definitive because, he writes, “a psychic element is conscious to me only in so far as it is related to my ego-complex” (p. 425).

The restriction of the ego to the field of consciousness is particularly significant for Jung and the development of his analytical psychology because in his diagnostic studies of associations in 1904 he had already been able to demonstrate unconscious complexes affecting the conscious mind and capable of causing disturbances in ego functioning. It was this work that had formed the basis for his agreement with Freud and his psychoanalytic theories.

However, following his break with Freud in 1913, Jung embarked on a clearer elaboration of his own psychological theories. His personal experience had led him to emphasize the extremely important role of a firm anchoring of the conscious viewpoint in the ego because, as he explained, the ego not only has to manage the conflicts with the external world but also to confront intrapsychic material that manifests and operates from the unconscious.

His entire interest was henceforth directed at investigating the contents of the unconscious. This led him to the following discovery: To the extent that the ego approaches unconscious material in a way that is both receptive and critical, it becomes clear that an organizational element is at work there, such that dreams, for example, can be considered to interrelate with a meaningful process of transformation. This suggested the obvious hypothesis that it is not only our conscious ego that possesses a capacity for organization, initiative and purpose: It is in fact the development of our personality in its entirety, including our potential for consciousness, that is “directed” by a center operating in the unconscious.

To distinguish it from the ego, Jung called this center the “Self.” To the definition of the ego-complex quoted above, he therefore added the following point: “But inasmuch as the ego is only the centre of my field of consciousness, it is not identical with the totality of my psyche. . . . I therefore distinguish between the ego



and the *self*, since the ego is only the subject of my consciousness, while the self is the subject of my total psyche, which also includes the unconscious” (p. 425).

Jung devoted himself principally to the interaction between the ego and the unconscious and to the question of discovering how the ego can gain experience of a Self that is subordinate to it. He demonstrated that this is a task that belongs to the individuation process in the second half of life, which presupposes and requires the existence of a strong enough ego that can allow itself to be substantially influenced by the Self without thereby succumbing to a loss of boundaries that would be pathological if not psychotic. Something that Jung did not undertake to explain at great length was the question of knowing how it is that the Self, as a guiding agency of psychic development, stimulates and guides an appropriate maturation of the ego, and it is principally his successors who have worked on this (Neumann, 1963/1973; Fordham, 1969).

MARIO JACOBY

*See also:* Animus-anima; Collective unconscious (analytical psychology); Compensation (analytical psychology); Ego; Numinous (analytical psychology); Self (analytical psychology); Shadow (analytical psychology).

### **Bibliography**

- Fordham, Michael. (1969). *Children as individuals*. London: Hodder & Stoughton.
- Jacoby, Mario. (1990). *Individuation and Narcissism: The Psychology of the Self in Jung and Kohut* (Myron Gubitz, Trans.). London and New York: Routledge. (Original work published 1985)
- . (1904–1906). Experimental researches. *Coll. Works*, Vol. II. London: Routledge & Kegan Paul.
- . (1921). Psychological types. *Coll. Works*, Vol. VI. London: Routledge & Kegan Paul.
- Neumann, Erich. (1973). *The child: structure and dynamics of the nascent personality* (Ralph Manheim, Trans.). London: Hodder and Stoughton. (Original work published 1963)

---

## **EGO AND THE ID, THE**

Published in German in 1923, *The Ego and the Id* was the work in which Freud sought to summarize in the most explicit manner the far-reaching metapsychological revisions he made to his theory in the 1920s. The

text begins by recalling the basic distinctions of the topographical theory: distinctions among the conscious, the preconscious (descriptively unconscious but susceptible of becoming conscious), and the dynamic unconscious (the repressed, which can become conscious only by penetrating the barrier of repression, for example, by means of the psychoanalytic method).

In this work Freud emphasized that the resistances of the ego, as encountered in the work of analysis, were themselves in part unconscious. So even if the conscious-unconscious opposition was still an essential point of reference, the unconscious could no longer be considered a psychic agency. Freud thus had to revisit the whole topographical system of his theory.

Freud concerns himself first with the characteristics of the ego, its relationships with the perception-consciousness system and with language, which underpin the possibility of material becoming conscious. Sense perceptions are immediately conscious; thought processes become conscious through their links with the auditory traces of verbal residues (or word presentations), which endow those processes with a perceptual dimension. Internal perceptions, more deeply seated and elemental than external ones, derive from the pleasure-unpleasure series of sensations and become conscious directly, without any recourse to words, by projecting themselves onto the surface of the body.

The crucial point in Freud's argument concerns feelings. Analytic experience reveals that feelings may occasionally become conscious solely because the ego refuses to discharge them. This idea leads to the paradoxical notion of “unconscious feelings” (notably, the feeling of guilt). The ego thus emerges as an agency derived essentially from the body: Linked to perception and to the body envelope, it is sometimes described as “a surface entity,” but also as “the projection of a surface” (1923b, p. 26).

Freud's rejection of the unconscious as a system led him to include in the mental apparatus the id, which is far more extensive and less organized than just the repressed. He described the id as the great “reservoir” of the instincts, which originate in the somatic realm and express themselves there as dynamic impulses seeking discharge solely in accord with the dictates of the pleasure principle. The ego is that part of the id which has been modified by the influence of the external world: “For the ego, perception plays the part

which in the id falls to instinct" (1923b, p. 25). Freud compares the relationship of the ego to the id to that of a rider to his mount: Often the rider's energy is insufficient for him to do more than lead the horse where it wants to go.

To his structural theory Freud also introduced a third agency, reflecting the fact that the "highest" mental activity, notably that of the moral conscience, may be unconscious. The superego (or ideal ego), as evoked several years earlier in *On Narcissism: An Introduction* (1914c), is the outcome of a differentiation within the ego; the formative mechanism is narcissistic identification with a lost object (1917e [1915], pp. 241, 249–251). Internalization of the object in the ego facilitates replacing the instinctual cathexis of the object with a change in the ego that renders it similar to the object and thus capable of pleasing the id and being narcissistically cathected. The establishment of the superego depends on a mechanism of this sort: Obligated to renounce the cathexes characteristic of the Oedipus complex, the child redirects them onto the ego while identifying with the parents, at once desired and feared. The postoedipal superego, though essentially paternal in character, forms on the basis of two identifications (maternal and paternal), combined in one way or another. These secondary identifications (secondary, that is, to the instinctual cathexes that they replace) continue to reinforce a set of primary object identifications whose point was "to be [like] the other" rather than to "have" the other.

This web of identifications, reflecting the child's long dependency on the parents, gives a permanent character to the infant's relation to primordial objects and the dual protective and punitive significance of that relation. By treating the superego as a mental agency that "dominates" the ego, Freud accentuated the idea that the superego is just as immune as the id to a complete appropriation by the ego.

The tension between the ego and the superego manifests itself as a sense of guilt. The largely unconscious nature of the superego sheds light on negative therapeutic reactions, which, according to Freud, express a need for punishment (an unconscious feeling of guilt) that is satisfied by illness and suffering.

The superego is the agency whereby the heritage of civilization, which individuals must reappropriate for themselves, is transmitted. Here Freud recalled the thesis of *Totem and Taboo* (1912–1913a) concerning the

genesis of guilt and of the social bond created by the killing of the primal father, a thesis with profound implications for religion. The superego, projected and writ large, is the seed from which all religion springs.

The topography of psychic agencies thus outlined was inseparable from Freud's new conception of instinctual dualism. According to this conception, first set forth in *Beyond the Pleasure Principle* (1920g), Eros encompasses the instincts for self-preserved and sex (the conflict between them no longer being considered primary), whereas the death instincts express a primary self-destructiveness mediated by sadism, which redirects the death instincts outward in a partial fusion with erotic impulses. The essential characteristic of these two groups of instincts is their conservatism: The life instincts aim to preserve life by binding life with ever vaster wholes; the death instincts strive for a return to an inanimate state by unbinding and reducing tension to zero (the Nirvana principle).

Life presents itself as an unending struggle between the two kinds of instincts, always more or less blended or fused. But the process of identification, a consequence of the desexualization and transformation of cathexes into narcissistic libido, is accompanied by a diffusion that may ultimately result in the superego's becoming "a pure culture of the death instinct" (1923b, p. 53), as in melancholia. The same circumstances also enable the ego to sublimate the instincts, in conformity with the requirements of the ideal: The ego, with its "free" (narcissistic) energy, can transform love into hate (paranoia) or hate into love (homosexuality) (1923b, pp. 43–44).

In concluding *The Ego and the Id*, Freud attempts to sum up the "dependent relationships" of the ego, which has to serve three masters at the same time. As can be seen in the clinical aspects of the sense of guilt, the superego draws sustenance from the renunciations it requires, becoming more severe as aggression is displaced and turned against the ego. With respect to the id, the ego seeks to satisfy instinctual demands while simultaneously seeking to subject them to its will. And as for the external world, the ego is linked to it by being anchored in perception and by the workings of the reality principle, which constrains its use of judgment.

Three dangers and three types of anxiety are correlated with these three masters of the ego: moral anxiety (arising from conscience), neurotic anxiety (arising

from instincts), and realistic anxiety (arising from the reality principle). Freud emphasized the fact that the fear of death, seemingly so real, in fact derives from “moral” anxiety, itself the result of castration anxiety and of loss of love.

*The Ego and the Id* is a difficult text, not least because it is extremely concise as a result of its synthesizing ambitions. Freud himself was less than satisfied with it. The work was a recapitulation of ideas advanced by Freud since the completion of his metapsychology, and more particularly since *Beyond the Pleasure Principle* (1920g), but its implications would emerge only gradually with the appearance of later articles, most notably “The economic problem of masochism” (1924c), where Freud assessed the consequences of the repetition compulsion and the death instinct on the concept of the pleasure principle.

JEAN-LUC DONNET

See also: Ego; Id; Superego; Topographical point of view.

### Source Citation

Freud, Sigmund. (1923b). *Das Ich und das Es*, Leipzig-Wien-Zürich, Internationaler psychoanalytischer Verlag; *G.W.*, XIII, 237–289; The ego and the id. *SE*, 19: 1–66.

### Bibliography

- Freud, Sigmund. (1912–1913a). Totem and taboo. *SE*, 13: 1–161.
- . (1914c). On narcissism: An introduction. *SE*, 14: 67–102.
- . (1916–17g [1915]). Mourning and melancholia. *SE*, 14: 237–258.
- . (1920g). Beyond the pleasure principle. *SE*, 18: 1–64.
- . (1924c). The economic problem of masochism. *SE*, 19: 155–170.

---

## EGO AND THE MECHANISMS OF DEFENCE, THE

This work was first published in Vienna in 1936 and in English translation in London the following year, two years before Sigmund Freud’s death. The whole of Anna Freud’s work was marked by her clearly stated desire to win scientific status for psychoanalysis. With this in mind, she sought to integrate analysis into psychology,

to create what she called a “psychoanalytical psychology.” At the same time the schoolteaching career that she embarked upon before becoming a psychoanalyst would seem to be the origin of the pedagogical cast of her written work and her practice as a child analyst.

The frame of reference of *The Ego and the Mechanisms of Defence* is Freud’s second topography (structural theory). The subject of the book is the defenses developed by the individual ego in order to confront or avoid the conflicts provoked by the id in its relations with the ego and the superego. Anna Freud approaches psychoanalytic technique and theory, along with defensive formations, from the specific perspective of the observation of the ego through the mental conflicts in which it is involved. Thus the ego in its relations with the id and with the outside world—relations which may be the source of unpleasure or of feelings of fear—is analyzed in the light of its avoidance mechanisms (the various forms of negation), in the light of its aggressive or altruistic strategies. Special significance is assigned to the phenomena of puberty and to the defense mechanisms triggered by the re-emergence of sexuality at that time.

Anna Freud considers it the analyst’s task, “in relation to the ego, to explore its contents, its boundaries, and its functions, and to trace the history of its dependence on the outside world, the id, and the superego; and, in relation to the id, to give an account of the instincts, i.e. of the id contents, and to follow them through the transformations which they undergo” (p. 5). The fact is that when id derivatives make incursions into consciousness, the ego is prone to “counterattack” by deploying defense mechanisms (p. 7). But while the analyst is aided by the tendency of id derivatives to surface, at the same time no help is to be obtained by analyzing the ego’s defenses, for these can be reconstructed only by reference to the effects they produce in the patient’s associations. According to Anna Freud, the analysis of resistance to transference and the analysis of the compulsion to repeat need to be refined by analysis of the resistances of the ego. The purpose of these various psychoanalytical procedures is to bring into consciousness the ego’s unconscious defenses, which are liable to strengthen the patient’s hostility toward the analyst.

Anna Freud subjects the ego’s defenses to meticulous scrutiny and inventories their varieties on the basis of Freud’s descriptions. The list is as follows: regression, repression, reaction-formation, isolation, undoing, projection, introjection, turning against the self, and reversal into the opposite. To these Anna

Freud adds a tenth defense mechanism, namely sublimation or the displacement of instinctual aims.

Anna Freud's work, and in particular the book with which we are here concerned, has directly nourished a line of thinking that might be called a "psychoanalysis of consciousness," and that has achieved its greatest success in the United States thanks to the proponents of ego psychology (Hartmann, Kris, and Loewenstein, 1964); most importantly, however, it has indirectly made possible a psychological use of the findings of Freudian psychoanalysis in a number of areas, among them the field of what is known as "psychoanalytical pedagogy" and that of so-called personality testing.

ELSA SCHMID-KITSIKIS

*See also:* Defense; Ego.

### Source Citation

Freud, Anna. (1937). *The ego and the mechanisms of defence* (Cecil Baines, Trans.). London: Hogarth. (Original work published 1936)

### Bibliography

Hartmann, Heinz, Kris, Ernst, and Loewenstein, Rudolf M. (1964). *Papers on psychoanalytic psychology*. New York: International Universities Press.

Moll, Jeanne. (1989). *La pédagogie psychanalytique. Origine et histoire*. Paris: Dunod.

Sandler, Joseph. (1985). *The analysis of defense: the ego and the mechanisms of defense revisited*. New York: International Universities Press.

## EGO AUTONOMY

Heinz Hartmann introduced the concepts of primary and secondary ego autonomy in 1939, and elaborated on them in later writings (Hartmann, 1964). Within the framework of his description lies a conflict-free sphere of the ego. The notion of "ego autonomy" implies that the ego and the id derive from a common matrix where certain ego precursors prefigure functions destined to develop autonomously, independently of the instincts and their vicissitudes.

Primary and secondary autonomy involve two sets of hypotheses, which together constitute the conflict-free ego sphere. Hartmann replaced Freud's view that the

ego grows out of the id with the hypothesis that both ego and id are derived from a common undifferentiated medium.

Related concepts are change of function, neutralization, automatization, and ego interests. Hartmann focused especially on the autonomy of specific ego functions, and stressed that ego autonomy is relative, since both primary and secondarily autonomous components can be drawn into conflict.

Prior to Hartmann, psychoanalytic theory held that all psychic mechanisms and processes result from the effects of the influence of life experience on the instinctual drives. In primary autonomy, Hartmann identified constitutional factors influencing ego development in addition to instinctual drives and external reality. The ego apparatuses of perception, object comprehension, intention, thinking, and language capacity are all congenital, and are influenced by maturation and learning. But they are neither derived from conflict, nor are they developmentally dependent on conflict. Even so, these structures of primary autonomy can become caught up in conflict, resulting in inhibition of their functioning. This formulation took some of the explanatory burden off the concept of sublimation.

In secondary autonomy, behaviors and attitudes which are initially associated with a conflict between drive manifestations and defenses can become detached from their sources. This takes place through a change of function, made possible by a de-sexualization and a de-aggressivization of the associated mental energy. The degree of secondary autonomy is defined by how resistant the trend is to regressive re-instinctualization. More generally, both the stability of secondarily autonomous functions and ego strength can be defined by the capacity of the various ego functions to withstand regression in the face of a focal conflict. Insufficient secondary autonomy interferes with the ability to bind id strivings, and increases vulnerability to ego regression.

Neutralization is seen as the basis for secondary autonomy of ego interests, habits and skills, while ego interests include sets of ego functions that mostly entail secondary autonomy. They encompass what Freud called the ego instincts. Two ego interests in conflict are an example of an intrasystemic conflict.

Secondary autonomy is seen to be established through the structure-building process called automatization,

by means of the change of function via neutralization. Automatisms are ego apparatuses, somatic and preconscious, that are adaptive themselves, or are utilized by adaptive mechanisms.

David Rapaport (1951/1967; 1957/1967) saw a reciprocal relationship between the ego's autonomy from the drives on the one hand, and from the environment on the other. Autonomy from the drives is insured by the reality-related autonomous apparatuses, and from the environment by the endogenous drives.

Hartmann's formulations of ego autonomy have been highly influential in psychoanalysis. Most of his contributions stand, but serious questions have subsequently been raised about the scientific status and validity of energy transformations, which are part of the neutralization-deneutralization hypothesis.

MARVIN S. HURVICH

*See also:* Ego; Ego (ego psychology).

### **Bibliography**

- Bellak, Leopold; Hurvich, Marvin; and Gediman, Helen. (1973). *Ego functions in schizophrenics, neurotics and normals. A systematic study of conceptual, diagnostic and therapeutic aspects*. New York: Wiley.
- Hartmann, Heinz. (1939). *Essays on ego psychology*. New York: International Universities Press, 1964.
- . (1939). *Ego psychology and the problem of adaptation*. New York: International Universities Press, 1958.
- Hartmann, Heinz, Kris, Ernst, and Loewenstein, Rudolph M. (1964). *Papers on psychoanalytic psychology*. New York: International Universities Press.
- Rapaport, David. (1967). The autonomy of ego. In M. Gill (Ed.), *The collected papers of David Rapaport* (p. 357–367). New York: Basic Books. (Original work published 1951)
- . (1967). The theory of ego autonomy: A generalization. In M. Gill (Ed.), *The collected papers of David Rapaport* (p. 722–744). New York: Basic Books. (Original work published 1957)

---

## **EGO BOUNDARIES**

Ego boundaries, a key concept in the theory of Paul Federn, form a necessary basis for distinguishing real from not real. Federn saw it as a kind of sense organ that differentiates what is part of the ego at a given moment from all other psychic elements.

Federn employed the term ego to refer to a person's ongoing bodily and psychic experience, the "I," the self, one's identity. This phenomenological description can be contrasted with that of the ego in Freud's structural model.

Victor Tausk (1919/1933), in his paper on the "influencing machine," first utilized the concept of the regressive loss of ego boundaries as a symptom of schizophrenia. Paul Federn (1926/1952; 1928) viewed ego boundaries as a key element in all ego functioning and postulated a boundary between the ego and the external world, which is subject to perception. He further extended the boundary concept by identifying an internal boundary between the ego and the unconscious, open to introspection.

In agreement with Freud, Federn understood the earliest differentiation between external and internal to result from body movements. Such a distinction eventually results in the establishment of dynamic (continually expanding and contracting) ego boundaries.

Federn's concept of ego boundary is closely associated with his other key concepts of ego feeling, ego state, and ego cathexis. Both ego boundary and ego feeling require for their maintenance an ego cathexis, which may be a blend of three kinds: libidinal, destructive, and self-preservative. When the inner boundary is critically weakened or lost, the return of repressed ego states falsifies reality and can result in delusions and hallucinations. When the cathexis of the outer boundary is weakened or lost, the sense of reality is disturbed, and external objects are discerned as unknown, strange, and unreal. Federn utilized his concepts of ego boundaries and sense of reality to clarify such phenomena as estrangement, depersonalization, delusions, hallucinations, dream experience, and drug effects.

Edith Jacobson (1954) has employed ego boundaries in psychoanalytic conceptualizations of the boundary between self and object representations. A remaining challenge is to work out the relationships among inner, outer, and self-object boundaries.

MARVIN S. HURVICH

*See also:* Ego; Ego psychology.

### **Bibliography**

- Bergmann, Martin S. (1963). The place of Paul Federn's ego psychology in psychoanalytic metapsychology. *Journal of the American Psychoanalytic Association*, 11, 97–116.

Federn, Paul. (1928). Narcissism in the structure of the ego. *International Journal of Psycho-analysis*, 9, 401–419.

———. (1952). *Ego psychology and the psychoses*. New York: Basic Books. (Original work published 1926.)

Jacobson, Edith. (1954). The self and the object world: Vicissitudes of their infantile cathexes and their influence on ideational and affective development. *Psychoanalytic Study of the Child*, 9, 75–127.

Tausk, Viktor. (1933). On the origin of the “influencing machine” in schizophrenia. *Psychoanalytic Quarterly*, 2, 519–556. (Original work published 1919)

See also: Ego; Ego (ego psychology).

### Bibliography

Weiss, Edoardo. (1951). Paul Federn’s scientific contributions: In commemoration. *International Journal of Psycho-analysis* 32 (4), 1–8.

———. (1952). *Introduction to Paul Federn’s ego psychology and the psychoses*. New York: Basic Books.

———. (1966). Paul Federn: the theory of the psychoses. In Franz Alexander, Samuel Eisenstein, and Martin Grotjahn (Eds.), *Psychoanalytic Pioneers*. New York: Basic Books.

## EGO, DAMAGE INFLICTED ON THE

A conception of the ego as a decisive agency of the mind was the point of departure of psychoanalytical ego psychology, which teaches that the ego may have a normal development (the approximate meaning of “normal” being “socially adapted”). According to Heinz Hartmann, adaptation is an essential task of the ego, one performed in a conflict-free, autonomous dimension of the ego distinct from the dimension of the ego dominated by the instincts. But this independent domain of the ego is liable to suffer many sorts of damage, whether at the beginning of life or later on. The most recent research on infancy has shown that one of the causes of such damage is a lack of adequate bonds with the mother or mother substitute. Genetic causes no doubt also play a part, but in this area the state of our knowledge is still rudimentary.

Apart from bonds with the mother or mother substitute, there are particular social conditions that can inflict severe damage on the ego, damage that in some cases is irreparable. The later in life that these injuries occur, the easier it is for the ego to repair them with dispatch. But if instinctual forces have inflicted added damage, then the ego may not prevail, because the libido is too weak or a destructive instinct is too powerful.

According to Paul Federn, damage of this kind may be sustained as a result of an early breakdown of ego boundaries. Where these boundaries are not well developed, they may at any time be overwhelmed by the destructive instinct, and death or suicide may ensue. Both these eventualities are possible in the course of childhood. In adolescence and adulthood, suicide is always the result of injuries to the ego; in old age, however, these considerations no longer apply.

ERNST FEDERN

## EGO (EGO PSYCHOLOGY)

The theories of the ego grouped under the rubric of “ego psychology” originated in Vienna before the Second World War and were developed in the United States by virtue of the migration of their chief proponents, namely Heinz Hartmann, Ernst Kris, and Rudolf Loewenstein. To these names must be added those of Paul Federn, of Hermann Nunberg, and of a good many other authors who helped give wide currency to conceptions of the ego that were destined to attract violent criticism, in France, from Jacques Lacan.

The substantial “*das Ich*” was so common in German (as was its equivalent in various other languages), that Freud, in the early part of his career, when he was actively searching for the new, paid it little mind. To begin with, Freud took the ego to be an indivisible unity, largely coextensive with the body, and therefore with consciousness. As Goethe had written, “To produce in oneself a new and better ego, thus to construct oneself as permanent, to live in oneself and create” (“*Ein neues besseres Ich in uns erzeugen, uns so ewig bilden, in uns fortleben und schaffen*”).

In 1914, however, Freud would write that the ego may at times “play the ludicrous part of the clown in a circus” (1914d, p. 53). We may say, in other words, that from the historical point of view psychoanalysis did not undertake an investigation of the ego before the First World War: Psychoanalysis was the science of the unconscious, whereas for Freud the ego belonged to the realm of consciousness. The notion of the ego is very hard to circumscribe and it has a different meaning for each psychological theory, so here we shall confine ourselves to the psychoanalytic sense. The translation of the term into languages other than

German further complicates the issue. The great confusion in English stems from the use of the Latin “ego” rather than the English “self” or “me.” In French there is ambiguity too, between “*le je*” and “*le Moi*.”

Freud believed that the ego developed like a skin over the unconscious (or, in his later accounts, over the id) and that it was not present from birth. The phenomenon of narcissistic cathexis led him to conclude that the ego was in part unconscious. The Unconscious/Preconscious/Conscious scheme thus came to seem inadequate, and Freud spent fifteen years working out a new subdivision of the mind into id, ego, and superego—“agencies” that his followers treated as structures. This was an error, for structures are static, whereas agencies are dynamic.

The origin of the ego became an essential issue for psychoanalysis, and has been responsible in part for the latter growth of research into early childhood. Historically speaking, after Freud’s death the notion of the ego eventually became the central preoccupation of psychoanalysis, to the detriment of the id. One reason for this was the increase of ego disturbances as compared with neurotic complaints, at least among analytic patients. Such disturbances were seen as the cause of perversions and other human behavioral problems. Certainly, the aphorism “*Zwei Seelen wohnen, ach, in meiner Brust*” (“Two souls reside, alas, in my breast”) had long been familiar, but it had engaged no clinical application. Further research into the psychology of the ego was undertaken in Freud’s wake, first by Anna Freud—who indeed began during her father’s lifetime—and then by Heinz Hartmann and Paul Federn.

According to Freud, the formation of the ego was a process that grew out of the bonds established with the mother or mother-substitute. Those bonds could in fact be looked upon as subject-object relationships, after the fashion of the English school. From its beginnings, the ego was the agency of the mind whose task it was to address the realities of life. Only thanks to the love and continual care of the mother or mother-substitute could adaptation to reality be achieved. Freud felt that this normally occurred during the third year of life, when the child’s ego was ready to adapt itself also, beyond the family circle, to the outside world as represented by the kindergarten.

The ego’s development did not stop at this point, however, but continued into adulthood, continually exposing the ego to innumerable dangers which

orientated it in this way or that. Genetic factors surely played a major role, even if this could not as yet be proved. Anna Freud emphasized that its development in childhood shaped the most important portion of the ego. Only when this development was arrested or when it regressed was therapeutic intervention called for.

In summary, the ego may be described as that agency which protects the id and which must come to terms with the demands of the superego. It represents in large part the individual’s social environment, although it is also strongly determined in its development by familial factors. A lack of love and acknowledgment during the first years of life may have two kinds of consequences: an autonomous ego may develop which is concerned only with itself, which is narcissistically cathected, and which is capable of achieving remarkable successes in reality without making genuine contact with other individuals or with society; alternatively, the ego may wither, failing either to fashion links with the outside world or to draw satisfaction from within. Between these two extremes every imaginable intermediate situation—or “ego state”—may be met with. But such ego states also depend on an outside world with the capacity to transform the ego-ideal into an ideal ego which, as early as the third year of life, allies itself with the superego to form an agency of great power in the life of the individual.

Thus the earliest object relationships produce distinct character types: an ego strong in its narcissism but socially ill-adapted; an ego that is weak, and undeveloped in all respects; or an ego that is bound to a strong superego and thus able to assert itself in the world. This last type is represented by highly religious individuals and probably constitutes the commonest form of human life.

The psychoanalytic psychology of the ego was inaugurated in 1923 with the publication of Freud’s major work *The Ego and the Id* (1923b). For Freud, the ego was intimately linked to the body, thus ensuring the basic unity of the human being. Assuming that everyone knew what the ego was, he offered no definition and confined himself to describing its functions. In 1929 Hermann Nunberg developed the notion of the ego’s synthetic function. Whereas Freud thought that after an analysis synthesis occurred spontaneously, Nunberg showed that it was in fact the work of the ego, whose essential task was to bring together the various tendencies of the human individual and place

them in the service of social life. Nunberg felt that the higher functions dependent on the ego, such as artistic and scientific activity, were in fact governed by it; Freud for his part thought they remained under the influence of the id, like a horseman on his mount.

In 1930, Anna Freud published a book dealing with other ego functions, notably the defenses. She argued that a set of human behaviors arose from the need to fend off danger, and that responsibility here fell to the ego. One of the most important defense mechanisms was identification with the aggressor as a way of conjuring away threats, but of course this ploy was not always successful. Repression, forgetting, and the splitting of the ego were other defensive tactics. The positive ego functions were synthesis and identification with the ideal ego.

After Freud's death, Heinz Hartmann expanded some ideas that he had presented earlier, proposing that the ego's most significant function was adaptation, made possible by virtue of the ego's two forms: on the one hand, the ego ruled by the instincts, and on the other, an ego free of conflict, which Hartmann called the self. For Hartmann the ego was entirely defined by its functions. He also held that a conflict-free ego was present from birth. Aberrant human behavior was in large measure the result of a failure to adapt to social conditions. This outcome occurred quite independently of the instincts, and it also had constitutional determinants. The "autonomous" ego could be overwhelmed by the aggressive instinct, which was the path to psychosis.

This account was defining for psychoanalytic ego psychology after the Second World War. It brought psychoanalysis back towards academic psychology, as also closer to individual psychology. It tended to make it more compatible with sociology and opened the way for it to become a natural science. It supplied the foundation for a psychoanalytic sociology that would trace the development of the social ego from infancy to old age, an approach pioneered in Erik Erikson's book *Childhood and Society* (1950). This conception of the ego also constituted a link to behavioral studies and relied on the observations of Jean Piaget, whose work on the development of intelligence in children buttresses the notion of an "autonomous ego." Finally, Hartmann's ego psychology led eventually to the psychology of the self developed by Heinz Kohut.

Hartmann's approach was in part the result of the transplantation of psychoanalysis to the English-speaking

world. An accurate English translation of *Ich* would have been "self"; the use of the Latin "ego" turned *Ichpsychologie* into "ego psychology—into something both strange and foreign-sounding. And "self," meanwhile, was translated into German as the *Selbst*.

Paul Federn's approach here was very different to Hartmann's. Drawing on his experience of analyzing a schizophrenic artist as early as 1905, as well as on his observations of other mental patients, and of himself, Federn concluded that the ego was the feeling of "*Ich bin Ich selbst*,"—"I am I myself," the sense of self-identity in time in space. He thus posed the question not in terms of the function but rather in terms of the essence of the ego.

ERNST FEDERN

*See also:* Adaptation; Alterations of the ego; Cathectic energy; Ego; Ego autonomy; Ego boundaries; Ego feeling; Ego Functions; Ego interests; Ego psychology; *Ego Psychology and the Problem of Adaptation*; Ego states; Ego-syntonic; Federn, Paul; Hartmann, Heinz; Identity; Kris, Ernst; Loewenstein, Rudolf M; Psychosexual development; Self; Self psychology; Self-image; Self-representation; Stage (or phase); United States.

### **Bibliography**

- Erikson, Erik H. (1950). *Childhood and society*. New York: Norton.
- Federn, Paul. (1926). *Ego-psychology and the psychoses* (E. Weiss, Ed.). New York: Basic Books, 1952.
- Freud, Anna. (1936). *The ego and the mechanisms of defence*. (Cecil Baines, Trans.). London: Hogarth, 1937.
- Freud, Sigmund. (1914d). On the history of the psychoanalytic movement. *SE*, 14: 1–66.
- . (1923b). The ego and the id. *SE*, 19: 1–66.
- Nunberg, Hermann. (1930). The synthetic function of the ego. *International Journal of Psycho-Analysis*, 7.

---

## **EGO FEELING**

Ego feeling is central to Paul Federn's ego psychology, together with ego boundary and ego state. It is one's experience of one's own bodily and mental existence, a phenomenological description of a connected psychic sensation, and involves the experience of space, time, and causality as an entity.

It is the experiential aspect of the ego boundary, the feeling by which the person is able to sense what is ego



and what is non-ego, and thus, what is real and not real. Paul Schilder also focused on the phenomenology of ego experience, especially in depersonalization and the experience of time. Federn (1926/1952) affirms a connection between his conception of ego feeling and Schilder's (1923/1953) concept of body schema.

For Federn, ego feeling is the simplest but also the most extensive psychic state present in the personality. Through a process of egotization, bodily and psychic elements attain ego feeling and inclusion within the ego boundary. He described bodily ego feeling (motor and sensory memories pertaining to one's person), mental ego feeling (reflecting inner perceptions), and superego feeling (the superego being an ego state with its own boundaries). Federn demonstrated how interrelationships among these different ego feelings change in different states of consciousness, such as in a normal awake state, in falling asleep and waking up, in dreams, in fainting, in ecstasy, in regression, and in the major psychopathological conditions.

An ego feeling pervades one's whole being while one is awake. But under conditions of fatigue, sleep, illness, and psychosis, the ego feeling is prone to serious restrictions. Ego feeling is intact when the ego is cathected, and is absent when there is no cathexis. Repression results in a depletion of ego cathexis. Disturbances in ego feeling reflects changes in ego cathexis and may result in severe anxiety and other mental symptoms, especially feelings of estrangement and depersonalization. Depersonalization involves de-egotization and is related to a fixation in the development of ego feeling.

Mental ego feeling is experienced as located inside the bodily ego during waking. In sleep, bodily ego feeling is the first to vanish, then superego feeling, while mental ego feeling remains the longest. There is an absence of ego feeling during states of dreamless sleep.

The formulation of the concept of ego feeling is one of Paul Federn's most original and valuable contributions, and presents a challenge to psychoanalytic theorists to utilize its potential.

MARVIN S. HURVICH

*See also:* Ego; Ego (ego psychology).

### **Bibliography**

Bergmann, Martin S. (1963). The place of Paul Federn's ego psychology in psychoanalytic metapsychology. *Journal of the American Psychoanalytic Association*, 11, 97–116.

Federn, Paul. (1952). *Ego psychology and the psychoses*. New York: Basic Books. (Original work published 1926)

Pao, Ping-Nie. (1975). The place of Federn's ego psychology in a contemporary theory of schizophrenia. *International Review of Psychoanalysis*, 2, 467–480.

Schilder, Paul. (1953). *Medical psychology* (David Rapaport, Trans.). New York: International Universities Press. (Original work published 1924)

Weiss, Edoardo. (1960). *The structure and dynamics of the human mind*. New York: Grune and Stratton.

---

## **EGO FUNCTIONS**

Sigmund Freud, and later Anna Freud, assigned to the ego tasks that involve the management of instincts and defenses against them. Some of their successors, among them Robert Waelder (1936), treated these tasks as "functions" that the ego was expected to fulfill. Thus such functions as integration, synthesis, and so on, were eventually distinguished. According to Heinz Hartmann, the ego should be evaluated according to how it performs these functions.

It is hard to say what the primitive function of the ego might have been, but, historically speaking, self-preservation is not only a function of the ego but also an instinct in its own right, originating in the ego—in short, an ego instinct. Freud first presented the concept of an ego instinct in *Beyond the Pleasure Principle* (1920g), where he also developed his theory of the death instinct. Briefly, the instinct for self-preservation can be subdivided into positive tendencies governed by the libido or Eros and negative tendencies subject to the death instinct. This account of the functions of the ego, which Freud himself always considered to be only a speculative hypothesis, was never accepted by more than a handful of analysts, even among those who granted the existence of aggressive and destructive instincts.

In the psychoanalytical ego psychology of 2005, these issues have ceased to carry much weight. The ego described in terms of its functions is no longer envisaged in the same way. True, Anglo-American psychoanalysis recognizes the notion of the death instinct, but the Anglo-American use of it is somewhat different from Freud's.

One essential function of the ego, according to Freud, is to synthesize all the impulses and energies of body and mind. This synthesis depends entirely on the

strength of the two psychic forces of the libido and the destructive, or death, instinct. To begin with, Freud (1930a, p. 117) had adopted Friedrich Schiller's antithesis of love and hunger, with love being equivalent to the libido and hunger standing for the self-preservation instinct. During the 1920s Freud replaced this idea by postulating the ego's synthetic function.

Another important ego function was defense and the signaling of danger. Danger might come from within (from the id), from without (from reality), or even from the superego. Against these threats the ego could defend itself in a variety of ways, depending on the individual. Among the ego's defensive functions were identification with the aggressor, forgetting, disavowal, and repression. Recognition, reflection, and above all action were also ego functions, yet the ego could feel pain, as in states of mourning or joy, and thus serve as vector of the emotions. The body ego, as the locus where instinctual impulses are discharged, was liable to come under the sway of the instincts, which could lead to brief depressions or to chronic mental illness.

Freud held that as a general rule the ego was the dominant mental agency, so long as it was functioning normally. Ego malfunction, in contrast, led to deep anxiety, and the weaker the ego the greater the anxiety. For this reason infantile anxiety was a normal state, whereas in adults it was a signal of danger. Its absence—loss of the feeling of anxiety—constituted a serious mental disturbance. Enumeration of the ego's functions pointed up the importance of the ego as an agency. Because it brought so many functions together, the ego was central to treatment and the nucleus of resistance. Freud recognized the ego as a major obstacle to psychoanalysis.

After Freud's death, ego psychology underwent considerable development, partly to the detriment of id psychology. This was a deviation in that when Freud set out on his research program, he was interested exclusively in unconscious mental life, in the depths of the mind, in a cauldron of energies that fulfilled no specific functions. Yet such energies are capable of modifying the ego in important ways, whether for good or for evil.

ERNST FEDERN

See also: Ego; Ego (ego psychology).

### **Bibliography**

Freud, Sigmund. (1920g). Beyond the pleasure principle. *SE*, 18: 1–64.

———. (1930a). Civilization and its discontents. *SE*, 21: 57–145.

Hartmann, Heinz. (1956). The ego concept in Freud's work. *International Journal of Psycho-Analysis*, 37, 425–438.

———. (1958). *Ego psychology and the problem of adaptation* (David Rapaport, Trans.). New York: International Universities Press. (Original work published 1939)

———. (1964). *Essays on ego psychology*. New York: International Universities Press.

Waelder, Robert. (1936). The principle of multiple function: observations on over-determination. *Psychoanalytic Quarterly*, 5, 45–62.

## **EGO IDEAL**

The concept of the ego ideal appeared for the first time in Sigmund Freud's "On Narcissism: An Introduction" (1914c). The ego ideal takes the place of the narcissism lost during childhood and promises the possible realization of narcissism in the future. Freud's concept of the ego ideal provided support for other, earlier concepts, such as moral conscience, censorship, and self-esteem, and made possible an original understanding of the formation of a mass movement and its relationship to a leader (1921c).

The ego ideal and superego, together with the ideal ego, form a group of agencies that should be clearly distinguished, even though Freud sometimes used the first two interchangeably. Freud introduced the superego in *The Ego and the Id* (1923b). It enabled him to distinguish the normative aspect of the psyche (the superego) from the motivational aspect directed toward a goal (the ego ideal). Originally, however, the two aspects were present in the ego ideal, which was also not differentiated from the ideal ego. This lack of differentiation reappeared in *New Introductory Lectures on Psycho-Analysis* (1933a [1932]), where the ego ideal became a function of the superego.

The ego ideal is formed when the child, through the crucial influence of parents, educators, and others in the environment, is forced to abandon its infantile narcissism. This is made possible by the formation of this substitute, the ego ideal, which leaves open the possibility that in the future the child will be able to rejoin ego and ideal. This development of the child's ego ideal, here conflated with the superego, occurs through the child's identification with the parents or, more precisely, with the parents' superego. In *The Ego and the Id* (1923b), Freud

indicates that the superego develops from identification with the paternal model. For identification to take place, the erotic component has to be sublimated. As a result, it no longer has the strength to bind the destructive component of the psyche. All of this creates a libidinal split. Consequently, the superego becomes harsh, even self-destructive. Out of this arises a feeling of unconscious guilt, and in melancholia the child finds the same ego ideal, dissociated from the ego, raging against it.

The ego ideal demands that the subject make changes to achieve the ideal, but the existence of the ego ideal does not mean that the subject has succeeded in achieving this goal. "A man who has exchanged his narcissism for homage to a high ego ideal has not necessarily on that account succeeded in sublimating his libidinal instincts" (1914c, p. 94). Thus, the idealist may refuse to see reality, including that of his own libidinal experience, even though he has not sublimated anything, in the sense of modifying the goal and object of the drive.

To the extent that the ego ideal is conflated with the superego, it includes the moral conscience, which continuously compares the actual ego with the ego ideal. Similarly, dream censorship and repression can be associated with the ego ideal. In fact, the ego ideal comprises all the restrictions to which the ego must submit to conform with the image detached from its own narcissism and projected before it. The ego ideal is not only a critic; when something in the ego coincides with the ego ideal, it can also produce a sensation of triumph, in which self-esteem is enhanced.

When the ego ideal is replaced by an idealized object, the ego ideal can be short-circuited in inciting the ego. "It is even obvious in many forms of love-choice," Freud wrote, "that the object serves as a substitute for some unattained ego ideal of our own" (1921c, p. 112). This notion led Piera Aulagnier (1979) to develop the concept of alienation, where the relationship is libidinal in nature since it involves another subject, an object (gambling or drugs, for example), or even an activity (sports, work).

With the concept of the ego ideal, Freud considerably enriched the understanding of group psychology. Starting from an analysis of the relation between hypnotizer and hypnotist, he defined the group as "a number of individuals who have put one and the same object in the place of their ego ideal and have consequently identified themselves with one another in their ego" (1921c, p. 116). All in the group are then collectively capable of

being subjected to whatever represents this now collective ego ideal. The consequences are well known. "The criticism exercised by that agency [the ego ideal] is silent; everything that the object does and asks for is right and blameless. Conscience has no application to anything that is done for the sake of the object; in the blindness of love remorselessness is carried to the pitch of crime. The whole situation can be completely summarized in a formula: The object has been put in the place of the ego ideal" (1921c, p. 113).

Daniel Lagache (1961), in discussing the structure of the personality, identified the notion of "heroic identification," the narcissistic ideal of omnipotence, which allowed him to explain certain aspects of criminal behavior. Janine Chasseguet-Smirgel (1985) identified various possible outcomes for the ego ideal, perverse as well as creative.

SOPHIE DE MIJOLLA-MELLOR

*See also:* Alienation; Character neurosis; Collective psychology; Heroic self; Ego ideal/ideal ego; Narcissistic transference; Self-image; Shame.

### **Bibliography**

- Aulagnier, Piera. (1979). *Les destins du plaisir: Aliénation, amour, passion*. Paris: Presses Universitaires de France.
- Chasseguet-Smirgel, Janine. (1985). *The ego ideal: A psychoanalytic essay on the malady of the ideal* (Paul Barrows, Trans.). London: Free Association Books. (Original work published 1975)
- Freud, Sigmund. (1914c). On narcissism: An introduction. *SE*, 14: 67–102.
- . (1921c). Group psychology and the analysis of the ego. *SE*, 18: 65–143.
- . (1923b). The ego and the id. *SE*, 19: 1–66.
- . (1933a [1932]). New introductory lectures on psycho-analysis. *SE*, 22: 1–182.
- Lagache, Daniel. (1961). La psychanalyse et la structure de la personnalité. *Psychanalyse*, 6, 5–54.

### **Further Reading**

- Blos, Peter. (1974). The genealogy of the ego ideal. *Psychoanalytic Study of the Child*, 29, 43–88.
- Deutsch, Helene. (1964). Some clinical considerations of the ego ideal. *Journal of the American Psychoanalytic Association*, 12, 512–516.

Milrod, David. (1990). The ego ideal. *Psychoanalytic Study of the Child*, 45, 43–60.

Rosenfeld, Herbert. (1962). The superego and the ego-ideal. *International Journal of Psychoanalysis*, 43, 258–263.

Sandler, Joseph. et al. (1963). The ego ideal and the ideal self. *Psychoanalytic Study of the Child*, 18, 139–158.

Schafer, Roy. (1967). Ideals, the ego ideal, and the ideal self. *Psychological Issues*, 18, 129–174.

## EGO IDEAL/IDEAL EGO

The two notions of *ideal ego* and *ego ideal* might seem to be used interchangeably by Freud. However, their first appearance in “On Narcissism” (1914c) showed them to be different insofar as the ideal ego is taken to be the recipient of the self-love that the ego enjoyed in infancy. The distinction is between reality and an idealization of that reality, enforced by the fact that from infancy on, that reality seems forever lost. The ego ideal, on the other hand, is a dynamic notion: The person, as Freud wrote, seeks to regain the narcissistic perfection of its infancy under the new form of the ego ideal, which is deferred as a goal to be attained in the future. Thus the ideal ego could be seen as the nostalgic survival of a lost narcissism, while the ego ideal appears to be the dynamic formation that sustains ambitions towards progress.

The ideal ego is a modification of infantile narcissism and the omnipotence that accompanies it. What differentiates it from the ego ideal is that in the case of the latter, the ego only obtains the self-esteem that it yearns for by obeying the injunctions arising from what Freud later called the superego. On the other hand, the ideal ego is not completely equivalent with the ego since omnipotence is lost with infantile narcissism. Such omnipotence is only partially regained in daydreams and fantasies that make the person a hero and victor. The difference here is that the ego ideal, which is closely related to the superego, is not formed on the basis of an illusory omnipotence, but modeled after that of the parents, and more precisely after the superego and its ideals. The ideal ego thus appears to be a way of short-circuiting the work that the ego ideal requires by assuming that its goals, or any others that might be still higher, have already been attained.

Hermann Nunberg defined the ideal ego as the combination of the ego and the id. This agency is the outcome of omnipotent narcissism and is manifested as

pathology. Daniel Lagache (1961) developed the implications of this notion of the ideal ego, notably in terms of delinquency. The ideal ego appears in contrast to the superego and is linked to the primary identification with another being who is invested with omnipotence, as is the case with the infant’s identification with the phallic mother. Lagache emphasizes that in adolescence “the ideal ego is reinvested or its investment is strengthened, often by new identifications with eminent people. The adolescent identifies him- or herself anew with the ideal ego and strives by this means to separate from the superego and the ego ideal” (Lagache, pp. 227–28).

Lacan took up Lagache’s analysis of the concept in these terms: “In a subject’s relation to the other as an authority, the ego-ideal, obeying the law to please, leads the subject to displease himself as the price of obeying the commandment; the ideal ego, at the risk of displeasing, triumphs only by displeasing in spite of the commandment” (1966, p. 671). For Lacan, the ideal ego is a narcissistic formation linked to the mirror stage.

SOPHIE DE MIJOLLA-MELLOR

*See also:* Graph of Desire; Identification; Imaginary; Imaginary identification/symbolic identification; L and R schemas; Law of the father; Optical schema; Self-image; Unary trait.

## Bibliography

- Freud, Sigmund. (1914c). On Narcissism: An Introduction. *SE*, 14: 67–102.
- Lacan, Jacques. (1966). *Écrits*. Paris: Seuil.
- . (2004). *Écrits: A selection* (Bruce Fink, Trans.). New York: W. W. Norton.
- Lagache, Daniel. (1961). La psychanalyse et la structure de la personnalité. In *Oeuvres IV, 1956–1962*. Paris: Presses Universitaires de France, 1982.
- Nunberg, Hermann. *Principles of psychoanalysis*. New York: International Universities Press, 1955.

## EGO IDENTITY

It is too easy to see a patient only as a group of symptoms. Rather, according to Erik Erikson, the main issue is to determine whether it is a question of a person having a neurosis, or of the neurosis “having” the person. He insisted on the need to see fears and anxieties as two very different things: The former

apprehensions focus on realistic responses to dangers, whereas the latter, provoked by dysfunction in the internal controls, magnify obstacles without providing the means to surmount them.

Adaptive responses that are appropriate to reality are all too likely to be discounted if one understands the ego as being essentially a collection of defenses against the internal drives. The key, according to Erikson, is to seek in the ego the organizational capacities that create the strength necessary for reconciling discontinuities and ambiguities.

Like Sigmund Freud, Erikson envisioned an unconscious ego. But like other post-Freudians, he emphasized that the ego has a unifying function and ensures coherent behavior and conduct. The ego does not only have a negative function, that of avoiding anxiety; it plays as well the positive role of ensuring efficient functioning. The ego's defenses are not necessarily pathogenic: Some are adaptive, while others are the source of maladaptations. It is true that anxiety and feelings of guilt can disrupt adaptation. Moreover, the external environment has its own inherent deficiencies. But in attempting to measure the strength of the ego, Erikson did not limit himself to the earlier psychoanalytic norm and seek, in a personality, only that which is denied or cut off. Rather, he was interested in measuring the limit that the individual's ego is capable of unifying.

The ego protects the person's indivisibility, and everything that underlies the strength of the ego adds to its identity. If Freud understood identity as being in part acquired, this was due to the very particular types of patients he had treated.

For Erikson, identity is what maintains in the individual inner solidarity with the ideals and aspirations of social groups. The ego has a general balancing function: It puts things in perspective and prepares them in view of possible action. The strength of the ego, as Erikson conceived it, explains the difference between the feeling of being whole and the feeling of being fragmented. In the best of cases, it enables the individual to understand that the feeling of being at one with oneself comes through growth and development.

In addition to a feeling of continuity, according to Erikson, every individual needs a sense of novelty, obtained only through the leeway inherent in an assured identity. By "leeway," he meant maintaining in our experience a centrality, an evident self that, alone, enables us to make fully aware choices.

Early in his work Erikson called this identity "ego identity" after the model of Freud's "ego ideal." As a subsystem of the ego, identity's task is to choose and integrate self-representations derived from childhood psychosocial crises. Too often, in the history of psychoanalysis, there has been a tendency to forget that on the clinical level, the ego was posited as an enduring agent of selection and integration that plays a central role in the sound functioning of the personality. This inner "synthesizer," which silently organizes a coherent experience and guides action, is precisely what is so often lacking in present-day patients. By contrast, the patients of the earliest psychoanalyses were for the most part suffering from inhibitions that prevented them from being what they were, or what they believed themselves to be.

PAUL ROAZEN

See also: Erikson, Erik Homberger; Identity.

### Bibliography

- Erikson, Erik H. (1950). *Childhood and society*. New York: W. W. Norton.
- . (1959). *Identity and the life cycle*. New York: International Universities Press.
- . (1968). *Identity: Youth and crisis*. New York: W. W. Norton.
- Roazen, Paul. (1976). *Erik H. Erikson: The power and limits of a vision*. Northvale, NJ: Jason Aronson.

---

## EGO-INSTINCTS

In Freud's first theory of the instincts (or drives), the ego-instincts were contrasted with the sexual ones. In psychic conflict, a portion of instinctual energy is placed at the service of the ego. But even though their aim is the self-preservation and the self-affirmation of the individual, the ego-instincts nevertheless provide anaclitic support to the sexual drive. Freud later replaced this first opposition by another, that between the life instinct and the death instinct, assigning both the ego-instincts and the sexual instincts to Eros (the life instinct).

The term appeared first in the *Minutes of the Vienna Psychoanalytic Society* for March 10, 1910, where it was stated that reaction was made up of the "vicissitudes of the ego instincts," and soon after in Freud's "The Psycho-Analytic View of Psychogenic Disturbance of Vision" (1910i): "From the point of view of our

attempted explanation, a quite specially important part is played by the undeniable opposition between the [instincts] which subserve sexuality, the attainment of sexual pleasure, and those other [instincts] which have as their aim the self-preservation of the individual—the ego-[instincts]” (p. 214). Freud stated the idea more clearly apropos of the Schreber case: “We regard the [instinct] as being the concept on the frontier-line between the somatic and the mental, and see in it the psychical representative of organic forces. Further, we accept the popular distinction between ego-[instinct] and a sexual [instinct]; for such a distinction seems to agree with the biological conception that the individual has a double orientation, aiming on the one hand at self-preservation and on the other at the preservation of the species” (1911c [1910], p. 74). The sources of the ego-instinct are excitations emanating from the great organic functions, such as nutrition and vision, that ensure the continuation of life. The ego-instinct is thus quickly obliged to take the reality principle into account, and this consideration gives rise to the idea of a reality-ego that “need do nothing but strive for what is *useful* and guard itself against damage” (1911b, p. 223).

Thanks to Freud’s researches into narcissism, the notion that instinctual pressure was a kind of energy (earlier described as “interest”), led to the idea that ego-libido, or narcissistic libido, was the “great reservoir” from which object-cathexis is sent out and into which it may be withdrawn. The object of the ego-instincts is at first the object of need (food), and later anything that can contribute not only to strengthening the ego’s own operations, but also to inhibiting the primary process by the binding of ideas. Thus, secondarily, the ego becomes the object of libidinal cathexis. Its aim is self-preservation and the self-affirmation of the individual.

In 1915, Freud, showed that “only primal [instincts]—those which cannot be further dissected—can lay claim to importance” (1915c, p. 124). He then distinguished between two classes of primal instincts: “the *ego*, or *self-preservative*, [instincts] and the *sexual* [instincts]” (p. 124). The sexual instincts are at first “attached to the [instincts] of self-preservation, from which they only gradually become separated; in their choice of object, too, they follow the paths that are indicated to them by the ego-instincts” (p. 126).

In “A Difficulty in the Path of Psycho-Analysis” (1917a [1916]), Freud drew a parallel between the libido, as the force of the sexual drives, and hunger and the will to power as the power of the ego-instincts.

He then derived a certain category of neuroses from the conflict between the ego-instincts and the sexual instincts. Since the introduction of narcissism in 1914, however, he had contrasted two types of libido connected with the sexual drives, one type that was directed towards the object and the other that was directed towards the ego. The opposition between object-libido and ego-libido eventually replaced the distinction between ego-instincts and sexual instincts and paved the way for Freud’s final theory of the instincts.

In *Beyond the Pleasure Principle* (1920g), where Freud formulated his theory of the death instinct, he wrote: “The upshot of our enquiry so far has been the drawing of a sharp distinction between the ‘ego-instincts’ and the sexual instincts, and the view that the former exercise pressure towards death and the latter towards a prolongation of life. But this conclusion is bound to be unsatisfactory in many respects even to ourselves” (1920g, p. 44).

In *Civilization and Its Discontents* (1930a [1929]), Freud elaborated on the antithesis between ego-instincts and the object-instincts (p. 117). Then, in “The Dissection of the Psychological Personality,” the thirty-first lecture of the *New Introductory Lectures* (1933a [1932]), he specifically named the ego-instincts as a resisting force, insofar as they repelled and repressed the claims of sexual life (p. 57). In the thirty-second lecture, “Anxiety and Instinctual Life,” he attributed to the ego-instincts the same qualities as to the sexual instincts, apart from hunger and thirst, which were “inflexible, admit of no delay, [and] are imperative” (p. 97).

Though Freud continued to contrast ego-instincts and sexual instincts until 1920, the dualism between the life and death instincts inevitably relegated the ego-instincts to a subsidiary note. But some ambiguity remained, however, in Freud’s second topography (or “structural theory”), for in *Beyond the Pleasure Principle* (1920g), he subsumed the ego-instincts under the death instinct while still maintaining that they were at least partly libidinal in character.

PIERRE DELION

*See also:* Amae, concept of; “Claims of Psychoanalysis to Scientific Interest”; Drive/instinct; Ego; Ego autonomy; Ego-libido/object-libido; Hatred; Need for causality; Psychogenic blindness; Regression; Schiller and psychoanalysis; Self-preservation; Suicide.

**Bibliography**

- Freud, Sigmund. (1910i). The psycho-analytic view of psychogenic disturbance of vision. *SE*, 11: 209–218.
- . (1911b). Formulations on the two principles of mental functioning. *SE*, 12: 213–226.
- . (1911c [1910]). Psycho-analytic notes on an autobiographical account of a case of paranoia (Dementia paranoides). *SE*, 12: 1–82.
- . (1914c). On narcissism: an introduction. *SE*, 14: 67–102.
- . (1915c). Instincts and their vicissitudes. *SE*, 14: 109–140.
- . (1917a [1916]). A difficulty in the path of psycho-analysis. *SE*, 17: 135–144.
- . (1920g). Beyond the pleasure principle. *SE*, 18: 1–64.
- . (1930a [1929]). Civilization and its discontents. *SE*, 21: 57–145.
- . (1933a [1932]). New introductory lectures on psycho-analysis. *SE*, 22: 1–182.
- Nunberg, Hermann, and Federn, Ernst. (1962–1975). *Minutes of the Vienna Psychoanalytic Society*. New York: International Universities Press.

**Further Reading**

- Young-Bruehl, Elisabeth, and Bethelard, Faith. (1999). The hidden history of the ego instincts. *Psychoanalytic Review*, 86, 823–852.

**EGO INTERESTS**

The notion of ego interests points up a distinction between what serves the ego and what may harm it or place it in danger, as for example the pressures of the id, the commands of the superego, or simply love of an external object.

Freud used the term at least twice in his writings, once in the twenty-sixth Introductory Lecture, “The libido theory and narcissism” (1916–1917a, p. 414) and again in the paper “Analysis terminable and interminable” (1937c). In both contexts, Freud used the concept of the ego to mean an autonomous agency of mental life that makes no secret of its interests and can defend itself against the id and the superego. This defense can go as far as a refusal of all analysis, thus putting the treatment in jeopardy. In such cases one is confronted by resistance from the ego.

Even if it is rare, Freud’s use of “ego interests” demonstrates that in his work he by no means neglected to take the ego into account. It is true, however, that Freud long concentrated his attention on the depths of the unconscious part of the mind, as shown by the epigraph he chose for *The Interpretation of Dreams* (1900a): “Flectere si nequeo Superos, Acheronta movebo” (“If I cannot move the Higher Powers, I will move the Infernal Regions”), from the *Aeneid* (7.312). He thus declined to attend to the “higher world” of which the ego was an integral part. He nevertheless acknowledged that exploring the depths of the psyche represents a threat to the ego, that it is in the ego’s interest to recognize nothing beyond the conscious realm. But if this interest becomes too strong, overwhelming the functions that the ego is responsible for in company with the id and the superego, then behavioral problems will likely arise. Otherwise stated, it is in the ego’s interest to establish a working balance with the id and the superego, but if for whatever reason the ego is so strongly cathected that it no longer heeds either the id or the superego—a state known as “narcissism”—then there will occur disturbances of the kind that characterize what are now called “borderline cases,” disturbances that Freud considered unsuitable for psychoanalytic treatment.

With these considerations as his starting point, Heinz Hartmann brought to the fore a particular group of tendencies of the ego—the “ego interests”—embracing several disparate behaviors such as egoism, the pursuit of the “useful,” that is, of wealth, prestige, or power, but also that of intellectual acquisition.

ERNST FEDERN

*See also:* Ego; Ego (ego psychology).

**Bibliography**

- Freud, Sigmund. (1900). The interpretation of dreams (Parts 1–2). *SE*, 4: 1–338; 5: 339–625.
- . (1916–1917a). Introductory lectures on psycho-analysis (Parts 1–3). *SE*, 15: 9–239; 16: 243–463.
- . (1937c). Analysis terminable and interminable. *SE*, 23: 209–253.

**EGO-LIBIDO/OBJECT-LIBIDO**

In “On Narcissism: An Introduction,” Freud introduced a major modification in psychoanalytic theory,

particularly in libido theory, by making a distinction between two forms of libidinal cathexis: ego-directed and object-directed.

It was Carl Gustav Jung's studies on psychosis that led Freud to deepen and develop his own theory of the libido, which had hitherto been regarded solely as the energetic expression of the outwardly-directed sexual drives, leading to a break with his former student. At a period when there was a clear theoretical distinction between the sexual drives and the self-preservative drives, the case of the psychotic, cut off from reality and withdrawn into the self, seemed to substantiate the view (held by Jung) that the libido could be separated from sexuality and therefore had to be considered as a form of energy that was close to Henri Bergson's concept of *élan vital*.

In *Beyond the Pleasure Principle* (1920g), Freud commented that agreeing with "innovators like Jung who, making a hasty judgement, have used the word 'libido' to mean instinctual force in general" gives too much credence to "critics who have suspected from the first that psycho-analysis explains *everything* by sexuality" (p. 52). He then gave a response in theoretical terms in "On Narcissism: An Introduction" by suggesting that the libido initially cathected the ego, which he called "primary narcissism" and that it was only at a second stage that it was directed at the external world and towards the objects targeted by the drives: "Thus we form the idea of there being an original libidinal cathexis of the ego from which some is later given off to objects, but which fundamentally persists and is related to the object cathexes, much as the body of an amoeba is related to the pseudopodia which it puts out . . . We see also . . . an antithesis between ego-libido and object-libido" (1914c, pp. 75–76). In the same work, he went on to explain: "I should like at this point expressly to admit that the hypothesis of separate ego-instincts and sexual instincts (that is to say, the libido theory) rests scarcely at all upon a psychological basis, but derives its principal support from biology" (p. 79).

In the years that followed, Freud refined his description of this ego-libido that was soon to be called "narcissistic libido" by theorizing that it was possible for it to be turned back from an objectal current on to an ego that had itself become a love object: "secondary narcissism." He also drew a distinction between the repression in the transference neuroses, consisting in withdrawal of libido from consciousness and involving "the dissociation of the thing and word representa-

tions" from repression in the narcissistic neuroses, "which consists in the withdrawal of libido from the unconscious thing representations, which is of course a far deeper disturbance" (1965, p. 206; letter to Karl Abraham dated December 21, 1914).

From *Beyond the Pleasure Principle* onwards, the emphasis shifted from the conflict between ego-directed and object-directed libidinal drives to the conflict within the ego between Thanatos and Eros, as the concept that then subsumes the life drives in a constant attempt at cohesion (1920g).

Having assigned to the ego the role of "the great reservoir from which the object-cathexes are sent out and into which they are withdrawn once more" (p. 218) in a 1915 addendum to the *Three Essays on the Theory of Sexuality* (1905d), Freud later modified this proposition in his elaboration of the structural theory and wrote: "we must recognize the id as the great reservoir of libido" (1923b, p. 30, n. 1) and: "At the very beginning, all the libido is accumulated in the id, while the ego is still in process of formation or is still feeble. The id sends part of this libido out into erotic object-cathexes, whereupon the ego, now grown stronger, tries to get hold of this object-libido and to force itself on the id as a love-object. The narcissism of the ego is thus a secondary one, which has been withdrawn from objects" (p. 46). It is this secondary "ego narcissism" that is observed in psychotic states and narcissistic neuroses (dementia praecox, paranoia, melancholia, as Freud specified in his article "The Libido Theory" [1923a], written for the *Encyclopaedia Britannica*), in which the subject withdraws his libidinal cathexes from objects.

Should the metaphor of the "accumulators" found in the controversial book *Thomas Woodrow Wilson, Twenty-Eighth President of the United States: A Psychological Study* (1966 [1938]) be attributed to Freud? This text certainly states: "We have noted that the libido of the child charges five accumulators. Narcissism, passivity to the mother, passivity to the father, activity toward the mother and activity toward the father, and begins to discharge itself by way of these desires. A conflict between these different currents of the libido produces the Oedipus complex of the little boy" (p. 39).

The theoretical uncertainties relating to the sources of the libido and consequently to the validity of the opposition between the self-preservative "ego drives"



and the narcissistic ego-libido, a point on which Freud and Jung diverged, have led to a certain amount of debate and criticism, especially among English-language authors such as Heinz Hartmann, Rudolph Loewenstein, Michael Balint, and Heinz Kohut. This debate has given rise to most of the post-Freudian theories concerning narcissism and the distinction to be drawn between the “ego” and the “self.”

ALAIN DE MIJOLLA

*See also:* Libido.

### **Bibliography**

- Freud, Sigmund. (1905d). Three essays on the theory of sexuality. *SE*, 7: 123–243.
- . (1914c). On narcissism: An introduction. *SE*, 14: 67–102.
- . (1920g). Beyond the pleasure principle. *SE*, 18: 1–64.
- . (1923a). Encyclopedia article: The libido theory. *SE*, 18: 255–259.
- . (1923b). The ego and the id. *SE*, 19: 1–66.
- Freud, Sigmund, and Abraham, Karl. (1965). *A Psycho-Analytic Dialogue: The Letters of Sigmund Freud and Karl Abraham 1907–1926*. (Hilda C. Abraham and Ernst L. Freud, Eds.; Bernard Marsh and Hilda C. Abraham, Trans.). New York: Basic Books.
- Freud, Sigmund, and Bullitt, William C. (1966b [1938]). *Thomas Woodrow Wilson, Twenty-eighth President of the United States. A Psychological Study*. London-New York: Weidenfeld & Nicholson, 1967.
- Laplanche, Jean, and Pontalis, Jean-Bertrand. (1974). *The Language of Psycho-Analysis* (Donald Nicholson-Smith, Trans.). New York: Norton. (Original work published 1967)

## **EGO PSYCHOLOGY**

Publication of *The Ego and the Id* (1923b), where Freud initially described the tripartite model of id, ego, and superego as the key macrostructures of the mind, ushered ego psychology into psychoanalytic theory. Precursors can be found in Freud’s earlier publications: the “Project” of 1895; *The Interpretation of Dreams*; the metapsychological papers of 1915 on instincts, repression, and the unconscious; and the works on narcissism, mourning, and group psychology.

Freud’s book on anxiety (1926d) elaborated the structural theory of ego psychology and played a key role in its evolution. Its new model for symptom formation saw symptoms as arising from compromises among conflicts of the id, ego, and superego. This new formulation of the workings of the mental sphere was introduced as a revision Freud’s topographic model, an earlier theory centered on the relationship of mental contents to consciousness. For Freud, the antagonism between what is dynamically unconscious and what is conscious, and the significance of this difference for psychopathology, is fundamental to psychoanalysis. But he came to realize that both the repressed and repressing forces, as well as the sense of guilt, are unconscious—a clinically significant factor that he wanted to highlight. Freud saw that to enhance theoretical clarity and more accurately conceptualize the data from clinical psychoanalytic work, he needed a new framework for the mind.

In the inner workings of the theory, the id, which includes much of what had been the dynamic unconscious in the topographic model, operates as a primary process and is the major repository of psychic energy, the instincts, and a significant portion of what has been repressed, except for the unconscious aspects of the ego and the superego. The id seeks satisfaction of basic needs and wishes. The superego, in contrast, issues moral directives, self-reproach, and self-punishment and establishes values and ideals. Freud saw the ego as a coherent set of mental functions and a distillation of abandoned object cathexes. It represents reality, curbs impulses, and seeks the best compromise among the claims of the id, the superego, and the external environment. Freud’s concept of the ego has many different aspects and functions.

Delineating these aspects and functions constituted a major task for psychoanalytic theorists for the following half century and beyond. Anna Freud’s (1936/1966) depiction and organization of the major mechanisms of defense emphasized the defensive aspects of the ego. She stated the principle that id, ego, and superego derivatives merited equal attention from the psychoanalyst. Hartmann’s (1939/1964) notion that primary and secondary ego are autonomous delineated the ego as a substructure of the mind defined by its functions: broadly, its defensive, autonomous, and synthetic functions and their interrelations.

Therapy in the topographic model centers on making the unconscious conscious, and uncovering

universal-drive-related fantasies related to the various psychosexual stages of development. Therapy in ego psychology seeks to increase the scope of the ego at the expense of that of the id and, as a clinical correlate, to understand how the subject uniquely deals with danger and inner conflicts, encompassing id impulses, superego responses, and defensive, adaptive, and integrative ego solutions. Another technical implication of ego psychology is that the therapist should pay close attention to the organization and detail of conscious content while listening for its unconscious substrate. The emphasis on defense also brought into focus the issue of character resistance, systematically developed by Wilhelm Reich. Exploring character resistance later became an aspect of ego-psychology technique. Increasing knowledge of ego development and its relation to early object relations played a key role in the evolution of psychoanalytic ego psychology.

Current psychoanalytic approaches derived from ego psychology are Jacob A. Arlow's delineation of the unconscious fantasy, Charles Brenner's focus on conflict and compromise formation, and Paul Gray's development of close monitoring of the defensive process. Otto Kernberg has provided an integration of ego psychology and object-relations theory.

MARVIN S. HURVICH

### **Bibliography**

- Arlow, Jacob, and Brenner, Charles. (1964). *Psychoanalytic concepts and the structural theory*. New York: International Universities Press.
- Freud, Anna. (1966). *The ego and the mechanisms of defence* (Rev. ed.). New York: International Universities Press. (Original work published 1936)
- Freud, Sigmund. (1923). The ego and the id. *SE*, 19: 1–66.
- . (1926). Inhibitions, symptoms, and anxiety. *SE*, 20: 75–172.
- Hartmann, Heinz. (1964). *Essays on ego psychology*. New York: International Universities Press. (Original work published 1939)

### **Further Reading**

- Holt, Robert R. (1975). The past and future of ego psychology. *Psychoanalytic Quarterly*, 44:550–576.

Kris, Ernst. (1951). Ego psychology and interpretation in psychoanalytic therapy. *Psychoanalytic Quarterly*, 20, 15–30.

Wallerstein, Robert. (2002). The growth and transformation of American ego psychology. *Journal of the American Psychoanalytic Association*, 50, 135–170.

---

## **EGO-PSYCHOLOGY AND THE PSYCHOSES**

*Ego-Psychology and the Psychoses* consists of Edoardo Weiss's compilation of sixteen of Paul Federn's papers on ego psychology, his primary field. Federn (1871–1950), a member of Freud's inner circle, was one of the first psychoanalysts to treat psychotics. His psychoanalytic understanding was influenced by a phenomenological focus, his definition of the ego was experiential, and his major concepts were ego feelings, ego boundaries and ego states. As he understood it, in schizophrenia the ego is too weak to sustain the dominance of advanced ego states essential for mature functioning, due to overly-strong fixations on primitive ego states. Federn saw the prodromal phase of psychosis as beginning with a loss of ego cathexis, while Freud (1911c [1910]) emphasized the withdrawal of object cathexis. Federn supported his position by the observation that psychotics may maintain object interest in the presence of feelings of estrangement. Part of the difference in their respective formulations lay in the fact that Freud was attempting to explain the rapid appearance of delusions following a traumatic disappointment, while Federn focused on the incremental development of delusional ideas.

Federn recognized that psychotics were capable of strong transferences, which rendered them analyzable, but he also emphasized the challenge presented by the psychotic's mal-developed ego, idiosyncratic understanding of reality, and excessive, pathological narcissism. Federn held that these factors require a different application of psychoanalytic knowledge than the approach developed for the neurotic. His detailed treatment recommendations for psychotics were based on the implications of ego weaknesses. Regarding the understanding of the treatment of psychoses, Federn's concept of ego feelings preceded later interest in the sense of self, his view of faulty ego cathexis anticipated deficit theories of schizophrenia, and his work on the outer ego boundary shed light on contemporary con-

cerns with narcissistic object relations. His phenomenological insights and the problems with which he grappled have been of more lasting value than some of his detailed theoretical formulations.

MARVIN HURVICH

*See also:* Ego alterations; Ego; Ego (Ego psychology); Ego feeling; Federn, Paul.

### Source Citation

Federn, Paul. (1952). *Ego psychology and the psychoses*. (Edoardo Weiss, Ed.). New York: Basic Books.

### Bibliography

Bergmann, Martin S. (1963). The place of Paul Federn's ego psychology in psychoanalytic metapsychology. *Journal of the American Psychoanalytic Association*, 11, 97–116.

Freud, Sigmund. (1911c [1910]). Psychoanalytic notes on an autobiographical account of a case of paranoia. *SE*, 12: 3–82. London: Hogarth Press.

Pao, Ping-Nie. (1979). *Schizophrenic disorders: Theory and treatment from a psychodynamic point of view*. New York: International Universities Press.

Weiss, Edoardo. (1966). Paul Federn: The theory of the psychoses. In F. Alexander, S. Eisenstein and M. Grotjan (Eds.), *Psychoanalytic pioneers* (pp. 142–159). New York: Basic Books.

---

## EGO PSYCHOLOGY AND THE PROBLEM OF ADAPTATION

This work by Heinz Hartmann, some one hundred pages long, was presented to the Vienna Psychoanalytic Society in 1937, then published in book form in 1939. David Rapaport's English translation appeared in 1958. The ideas presented by Hartmann were already well known by then in the United States thanks to the German version, although in Europe, because of the Second World War, they gained wide currency only in the 1950s.

With these nine chapters, Hartmann extended Freudian psychoanalysis to the entire field of the psychology of consciousness, and in so doing brought aspects of modern ego psychology into that field for the first time. As his starting point, he took the idea that the ego was determined by its functions, thus

avoiding the question of its essence. According to Hartmann, the ego had many conflict-free functions whose basic task was adaptation to the external world. The ego and the id had emerged originally from a common matrix; obliged to define the boundaries between them, they created a zone of conflict whose essential *raison d'être* was defense. Simultaneously, a conflict-free zone developed that was dedicated fundamentally to adaptation to the outside world, and which included the body.

In this way psychoanalytic research was opened up to somatic and social phenomena and to all scientific disciplines concerned with these areas: primarily, the study of behavior, academic psychology, sociology, and anthropology. Although adaptation has features in common with defense, it is a function of a completely different order. It is the part played by resistance, above all, which distinguishes the two. The hypothesis of a conflict-free ego implies an autonomous status for that agency within a psychoanalytical psychology of the ego on a par with other human sciences.

ERNST FEDERN

*See also:* Adaptation; Defense mechanisms; Ego; Ego autonomy; Ego (ego psychology); Ego psychology; Desexualization; Hartmann, Heinz; Internal/external reality; United States.

### Source Citation

Hartmann, Heinz. (1958). *Ego psychology and the problem of adaptation* (David Rapaport, Trans.). New York: International Universities Press. (Original work published 1939)

---

## EGO STATES

An ego state is a coherent organization of cathected mental contents and related affects that are experienced as within the ego boundary at a given point in time. Federn's (1926/1952) concept of ego states is related to Schilder's (1930/1951) discussion of varieties of conscious experience and to David Rapaport's (1951/1954) view of states of consciousness. Federn's use of the construct ego state underscores mental content.

Ego states are correlated with particular ego boundaries, and the current contents included within a given

boundary will determine a particular ego state. Conversely, given ego states include particular qualities of ego experience. Ego states range from developmentally primitive to advanced. Any ego state may be repressed, and thus de-egotized. When a conflicting idea is repressed, the ego state in which it is found will also be repressed. For a repressed memory to become emotionally meaningful, there must be recall of the whole ego state in which it is embedded. A repeatedly cathected ego state may become dominant, and when this ego state is repressed, a fixation point is created. Fixations are associated with highly rigid ego boundaries. Activation of a particular ego state will result when there is a regression to that fixation point.

Manifest dream elements may primarily signify, in addition to unconscious fantasies, repressed ego states. The very concept of pathological fixations implies the notion of a number of repressed ego states. The unconscious segment of the ego consists of all repressed ego states. An active ego state reflects how one is presently experiencing oneself.

Ego states succeed one another, but a person may also experience different ego states at the same time. Even so, in most cases, one is aware of only one ego state at a given time. In ego states characterized by fatigue, sleep, illness, and psychosis, the ego feeling is often seriously restricted. In general, the greater the mental disturbance, the more the person's functioning is limited by current ego states. Such a person is unable to do in one ego state what he can do in another. Regression to earlier ego states is one of the main pathological features of psychosis.

MARVIN S. HURVICH

*See also:* Ego; Ego (ego psychology).

### **Bibliography**

- Bergmann, Martin S. (1963). The place of Paul Federn's ego psychology in psychoanalytic metapsychology. *Journal of the American Psychoanalytic Association*, 11, 97–116.
- Federn, Paul. (1952). *Ego-psychology and the psychoses* (Edoardo Weiss, Ed.). New York: Basic Books. (Original work published 1926)
- Rapaport, David. (1954). The autonomy of ego. In Robert P. Knight and C. R. Friedman (Eds.), *Psychoanalytic psychiatry and psychology*. New York: International Universities Press. (Original work published 1951)
- Schilder, Paul. (1951). Studies concerning the psychology and symptomatology of general paresis. In David Rapaport (Ed.), *Organization and pathology of thought*. New York: Columbia University Press. (Original work published 1930)
- Weiss, Edoardo. (1960). *The structure and dynamics of the human mind*. New York: Grune and Stratton.

---

## **EGO-SYNTONIC**

The notion of ego syntony plays an important part in psychoanalytic ego psychology. The implication of the term is that the ego represses only those tendencies with which it is at odds, that is, with which it is incompatible. Freud used the term only once, in the encyclopedia article "Psycho-Analysis," which first appeared in Max Marcuse's *Handwörterbuch der Sexualwissenschaft* (Manual of sexual sciences). "Since these impulses are not *ego-syntonic*," he wrote, "the ego has repressed them" (1923a, p. 246).

Obviously, compatibility between the ego and the id must vary according to the individual and also as a function of cultural and social affiliation. Sexual relations, for example, were long condemned by the Catholic Church unless their purpose was procreation. This position has gradually changed, but it is worth recalling that as recently as a hundred years ago Protestant circles subscribed to the same idea. In Asian societies attitudes towards sexuality are very different, although there too change is under way.

If much of sexuality is rejected by the ego of Westerners, this is not to say that other instinctual tendencies are likewise "ego-dystonic," and therefore repressed. In many aspects of aggression one can also see wide individual differences, depending not only on social position but also on historical period. In fact, if one considers the course of history from a psychological point of view, it is reasonable to say that up until the end of the Second World War most men experienced a resort to violence, even to killing, as perfectly ego-syntonic. In countries where the death penalty is still in use, as in the United States, inflicting this sanction on criminals is generally ego-syntonic, whereas in other countries this attitude has changed radically within the ego, and capital punishment is condemned by most people.

In the psychotherapy of present-day individuals, the therapist thus needs to bear in mind the historical trend for the ego to repress destructive impulses when it encounters them. Indeed, it is possible that sexual

impulses will become fully ego-syntonic, even as the ego rejects destructive wishes. In short, what is ego-syntonic and what is ego-dystonic must be determined in a historical, cultural, and social context.

ERNST FEDERN

*See also:* Ego; Ego (ego psychology).

### **Bibliography**

Freud, Sigmund. (1923a). Psycho-analysis. *SE*, 18: 234–254.

---

### **EINFALL.** *See* Sudden involuntary idea

---

### **EISSLER, KURT ROBERT (1908–1999)**

Physician and psychoanalyst Kurt Robert Eissler was born in Vienna on June 2, 1908, and died in New York on February 17, 1999.

Eissler was a Freud scholar of distinction, one of the most accomplished psychoanalysts of his generation, and a prolific and original writer. He was immensely learned, and a captivating and engaging speaker whose somewhat wry but engaging sense of humor augmented the liveliness with which he enriched discussion. His interests were wide ranging. The arts always appealed to him: His knowledge of them was extensive and he spoke and wrote of them with learning and wisdom. His book on Leonardo da Vinci (1962) was followed by his two-volume psychoanalytic study of Goethe (1963), and he made important contributions to the study of *Hamlet* (1953, 1968) and Freud's approach to literature (1968). He wrote about ageing and death, and his book, *The Psychiatrist and the Dying Patient* (1966), is of permanent value. In all, he wrote twelve books and nearly one hundred papers, among which his studies of psychoanalytic technique attracted wide attention. His writings cast light on many subjects, of which schizophrenia, dream analysis, female sexual development, memory and lightning calculation, psychological factors in hypertension, esophageal spasm, psychology of jealousy, body image disturbances, and suicide will serve as more or less typical random examples.

Eissler studied psychology at the University of Vienna. He took his Ph.D. in 1934 and his M.D. in

1937. After training at the Viennese Psychoanalytic Institute, he joined the Viennese Psychoanalytic Society. There he became an assistant to August Aichhorn, a pioneer in the study and treatment of adolescent delinquency, whose *Wayward Youth* became a classic text. Following the Anschluss in 1938, Eissler left for Chicago and obtained the diploma of the American Board of Psychiatry. During the Second World War, in 1943, he became a captain in the US Army Medical Corps, specializing in neuro-psychiatry. That autumn, his brother Erik was killed in a concentration camp, though it was only later that Eissler learned of his fate.

He moved to New York when the war ended, and set up in private practice. In 1949, he edited *Searchlights on Delinquency*, dedicated to his old teacher Aichhorn. In 1952, he was one of the founders of the Sigmund Freud Archives, deposited in the Library of Congress, Washington, DC, and it was as its tireless secretary that he collected so many invaluable documents about, by, or related to Freud and his associates. In this unending task he was greatly helped by Anna Freud, in the context of a warm relationship of mutual esteem. He had known her from Viennese days, and she found his friendship a great comfort. He established the Anna Freud Foundation in the United States, also in 1952, thus facilitating tax-free donations for the benefit of the Hampstead Child Therapy Course in London, and the associated clinic she had just set up. He strongly supported the work of what quickly became the world's leading center for child analytic training and for child analytic research. Anna Freud was secure in the knowledge that the Freud Archives were in safe hands, and that Eissler's devotion to all that her father stood for was absolute. She was grateful, too, for the invaluable assistance that he gave to Ernest Jones in his extensive three-volume biography of Freud, and to the help he gave to James Strachey in preparing the standard edition of Freud's psychological works.

Eissler was actively and deeply concerned about the growing flood of uninformed Freud criticism and the publicity it attracted. In particular, he objected to the misinterpretation of the early seduction theory. While Freud never denied that seduction in childhood had serious consequences for development, he was obliged to abandon his views of its role in the etiology of hysteria. Certainly, he would have hated the "recovered memory syndrome." All this is well known to serious

students of psychoanalysis, but Eissler brought to the bare facts an erudition that cast fresh light on the entire issue. An unexpectedly bitter dispute over his successor to the Archives, stemming from allegations that Freud had suppressed the truth about his early seduction theory, achieved wide publicity, while Eissler's refutation of the charges failed to be given due weight. Some other criticisms of Freud sprang from misunderstandings within the profession, and these were subject to Eissler's searching scrutiny. Again, this did not always attract the attention it deserved.

Eissler could not be said to be optimistic, either about psychoanalysis in particular or civilization in general. *The Fall of Man* (1975) makes melancholy reading. But, when reaffirming his pessimism during conversation, he would often add: "You have to go on fighting." He was certainly no idolater of Freud or Anna Freud, but vigorously defended those principles without which, he felt, psychoanalysis would cease to be psychoanalysis.

He was sometimes accused of imposing undue restrictions on access to the Freud Archives. Peter Gay, for example, in his biography of Freud (1988), after praising Eissler for his diligence in historical research, accused him of "an addiction to secrecy" (p. 784) in making a great deal of Freud's correspondence unavailable to scholars. That view is widespread, and Eissler (1993) felt obliged to defend the policy pursued by the Archives—a policy, he argued, seriously misrepresented. It was not, he said a matter of secrecy, but of making material available only to scholars and translators who were committed to accuracy: He pointed to the mischief already done by misreadings (not necessarily wilful) of Freud's difficult script, and pointed to the "glaring inaccuracies" in some translations previously published. It is a matter of some importance to read Gay's charges (p. 784f) and Eissler's reply (1993, pp. 202f, 212f) in full, in view of the widespread misunderstandings of the position then taken by the Freud Archives.

Eissler retained to the end an old-world charm and the courtesy and consideration of a Viennese gentleman. His stimulating observations were matched by a lively interest in the activities and opinions of his visitors, and his warm hospitality was a delight to those who knew him. His wife Ruth, for many years an editor of *The Psychoanalytic Study of the Child*, died in 1989.

CLIFFORD YORKE

*See also:* Eissler-Selke, Ruth; Lehrinstitut der Wiener Psychoanalytischen Vereinigung; *Leonardo da Vinci and a Memory of his Childhood*; New York Psychoanalytic Institute; Pankejeff Sergueï; Sigmund Freud Archives; Tausk, Viktor; War neurosis.

### Bibliography

- Eissler, Kurt R., (Ed.) (1949). *Searchlights on delinquency: New psychoanalytic studies*. New York: International Universities Press.
- Eissler, Kurt R. (1953). On Hamlet. *Samiksa*: 7: 85–202.
- . (1955). *The psychiatrist and the dying patient*. New York: International Universities Press.
- . (1962). *Leonardo da Vinci. Psychoanalytic notes on the enigma*. New York: International Universities Press.
- . (1963). *Goethe: A psychoanalytic study 1775–1786*. Two vols. Detroit: Wayne State University Press.
- . (1968). Freud's approach to literature — explaining and understanding. *Psychoanalytic Study of the Child*, 23, 141–77.
- . (1968). Fortinbras and Hamlet. *American Imago*: 25, 199–223.
- . (1975). The fall of man. *Psychoanalytic Study of the Child*, 30, 589–646.
- . (1993). *Three instances of injustice*. New York: International Universities Press.
- Gay, Peter (1988). *Freud: A life for our time*. London and Melbourne: Dent.

---

### EISSLER-SELKE, RUTH (1906–1989)

A physician and psychoanalyst, Ruth Eissler-Selke was born February 21, 1906, in Odessa and died October 7, 1989, in New York. She was born into a Jewish family, her father being the director of a German bank and then a grain exporter. After moving several times and attending schools in Odessa, Hamburg, and Danzig, Eissler-Selke completed her studies in 1925 in Freiburg-im-Breisgau. She studied medicine at the University of Freiburg, graduating in 1930. She specialized in psychiatry and, following graduation, practiced in Heidelberg and Stuttgart. Her dissertation, which she defended at the University of Heidelberg in 1932, was entitled "Medical Histories of Six Cases: The Contribution of Social Hygiene to the Question of Alcoholism and Tuberculosis."

After Hitler came to power, Eissler-Selke went into exile in 1933 in Vienna and worked at the psychiatric hospital in Rosenhügel. In December 1933, she requested admission to the training institute of the Vienna Psychoanalytic Society and began an analysis with Theodor Reik. After Reik's emigration to the Netherlands, she turned to Richard Sterba for her analysis. She was accepted as a member of the Vienna Psychoanalytic Society in 1937. While in Vienna she met Kurt R. Eissler, a doctor, philosopher, and later a psychoanalyst. They were married in 1936.

In March 1938, Kurt and Ruth Eissler emigrated to the United States and settled in Chicago. She became a member and training analyst of the Chicago Psychoanalytic Society and worked as a child psychiatrist at the Michael Reese Hospital. During the Second World War, she was a consulting physician in an institution for young delinquent women in Chicago. In 1948 she and her husband moved to New York and she became a member of, and training analyst with, the New York Psychoanalytic Society. From 1951 to 1957 she was secretary, then vice president of the International Psychoanalytic Association and, from 1950 to 1958, one of the editors of *The Psychoanalytic Study of the Child*, an annual publication founded in 1945 by Anna Freud, Heinz Hartmann, and Ernst Kris.

Aside from her teaching activities and psychoanalytic publications, she wrote poetry and a novel (unpublished), as well as several short stories. In 1976, to celebrate her seventieth birthday, a collection of her poems in German was published in New York.

ELKE MÜHLEITNER

*See also:* Eissler, Kurt Robert.

### **Bibliography**

- Eissler-Selke, Ruth. (1946). About the historical truth in a case of delusion. *Psychoanalytic Review*, 33, 442–459.
- . (1949). Observations in a home for delinquent girls. *Psychoanalytic Study of the Child*, 3–4, 449–460.
- . (1976). *Gezeiten: Gedichte in deutscher Sprache*. New York: Abaris Books.
- Eissler-Selke, Ruth, Blitzstein, N. Lionel, and Eissler, Kurt R. (1950). Emergence of hidden ego tendencies during dream analysis. *International Journal of Psycho-Analysis*, 31, 12–17.

Mühlleitner, Elke. (1992). *Biographisches Lexikon der Psychoanalyse (Die Mitglieder der Psychologischen Mittwoch-Gesellschaft und der Wiener Psychoanalytischen Vereinigung 1902–1938)*. Tübingen: Diskord.

## **EITINGON, MAX (1881–1943)**

Max Eitingon, a medical doctor, was born in Mohilev, Russia, in 1881 and died in Jerusalem on July 3, 1943. He was cofounder and president of the Berlin Psychoanalytic Polyclinic (1920–1933), director and patron of the Internationaler Psychoanalytischer Verlag (1921–1930), president of the International Psychoanalytic Association (1927–1933), founder and president of the International Training Committee (1925–1943), and founder of the Palestine Psychoanalytic Society (1934) and of the Psychoanalytic Institute of Israel.

Eitingon was born into an orthodox Jewish family. His father, Chaim Eitingon, had a large successful fur business, with a store in New York City. Max was the last of his four children (the others were Esther, Fanny, and Vladimir). Around 1893, when he was twelve, the family moved to Leipzig, Germany, where Chaim became a generous patron to the Jewish community, financing the construction of a hospital and a synagogue. In 1929 he was ruined by the stock market crash and died in Leipzig in 1932.

Educational problems, most likely associated with his stuttering, prevented Max from taking classes at the local high school, and he became a student in a private school that had a curriculum based on the study of modern languages. He learned to speak ten languages and later was able to take medical notes in several languages and dialects. However, because he did not have an opportunity to take his baccalaureate exams, he was not allowed to enroll in medical school and had to obtain a degree equivalent to the baccalaureate. He studied at various universities in Halle, Heidelberg, and Marburg, where Hermann Cohen, a specialist in Judaism, taught.

After this educational odyssey he began his medical studies in 1902 at the University of Leipzig. Eitingon completed everything but his dissertation when he left to become an intern at the Burghölzli Clinic in Zurich. Eugen Bleuler, head of the clinic, sent Eitingon to Freud with a patient because he wanted to discover what a psychiatrist could learn from a psychoanalyst. The “Minutes of the Vienna Psychoanalytic Society” note the presence of “Mr. Eitingon, of Bleuler’s clinic,

as guest” at the Wednesday evening meetings of January 23 and 30, 1907.

Eitingon was the first doctor from the Burghölzli Clinic to meet Freud. He served as an intermediary between Freud and psychiatry, but also asked to see him privately as a patient. Between 1908 and 1909 he underwent a five-week analysis during evening walks with Freud, a somewhat unusual venue for psychoanalysis. This was Freud’s first training analysis. We can assume that Eitingon discussed with Freud his relationship with his father and his inhibition about working. Presented these difficulties of Eitingon’s, Freud, who was very indulgent in his countertransference, appears to have been inclined to make Eitingon a “doctor of psychoanalysis.”

Eitingon, with the help of Carl Jung, finally managed to complete his dissertation: “Effect of an epileptic attack on mental associations.” He settled in Berlin, where his father’s fortune provided him with a life of comfort and ease among the intellectual and artistic elite of the city. On April 20, 1913, he married Mirra Jacovleina Raigorodsky, an actress from the Moscow Art Theater. During this period he had some time to help Karl Abraham introduce psychoanalysis to Berlin.

During the First World War, Eitingon became an Austrian citizen and joined the army as a physician. He was sent to Prague, Kassa, Iglo, and Miskolc (his birthplace), where he recommended Sándor Ferenczi as an expert for a military trial. In the hospitals Mirra worked with him as a volunteer nurse. He successfully treated cases of war trauma with hypnosis and was decorated several times for his work. He attended meetings of the Budapest Psychoanalytic Association, worked with Ferenczi on a psychoanalytic clinic, and attended the 1918 psychoanalytic congress.

At the end of the war, faced with an unstable political climate in Hungary, Eitingon left for Berlin, where he began his lifelong commitment to psychoanalysis. He had become a close friend of Freud in 1910 and remained his confidant during difficult times. In Freud’s words, he was the “first messenger [of psychoanalysis] to approach a solitary man [Freud].” With Ferenczi he played the role of a supportive disciple throughout the war years. A reliable individual, he was in a sense an administrator of the Freudian enterprise, resolving any problems that arose in the various local psychoanalytic societies (Zurich, for example).

He replaced Anton von Freund as a member of the Secret Committee (of Freud’s supporters) and continued his work in introducing psychoanalysis. In 1920 he took over work that had been done in Budapest and succeeded in creating a polyclinic in Berlin, whose construction he entrusted to Freud’s son, Ernst, an architect. He financed the polyclinic out of his personal fortune and ran it with the help of Karl Abraham and Ernst Simmel until the rise of National-Socialism in 1933.

The polyclinic was the first center in the world for treating patients with the Freudian psychoanalytic method and the first training institute for young analysts. The clinic trained candidates from all over the world to address the mental and social problems of postwar Europe. The curriculum lasted two years, then three, and comprised three separate tracks: theory, personal analysis, and supervised analysis.

After the death of his father, a cerebral thrombosis left him paralyzed in the left arm. On June 13, 1933, Eitingon presented Ferenczi’s funeral elegy in Budapest. Ruined, handicapped, and no longer able to bear the persecution in Berlin, he left Germany, on Freud’s advice, in September 1933. Because of his Zionist sympathies, he decided to emigrate to Palestine. He settled in Jerusalem, on Balfour Street, and there founded the Palestine Psychoanalytic Association (1934). In spite of Freud’s support, he failed to obtain a chair in psychoanalysis at the Hebrew University of Jerusalem.

In 1938 he was involved in a court case in Paris (the “Plevitskaya affair”) and suspected of being a Soviet spy. Vladimir Nabokov used this episode for the short story “The Assistant Producer.” Marie Bonaparte and René Laforgue testified on Eitingon’s behalf. Despite the French government’s official acknowledgement of “strategic error,” he was again accused of being a spy, this time posthumously, in the United States in 1988. A new controversy followed, but Eitingon’s reputation was cleared (Moreau Ricaud, 1992).

Eitingon was the author of some thirty articles, including “Genie, Talent und Psychoanalyse” (1912), “Gott und Vater” (1914), “Ein Fall von Verlesen” (1915), and twelve reports to various international psychoanalytic congresses, from Berlin 1922 to Paris 1938.

MICHELLE MOREAU RICAUD



See also: Berliner Psychoanalytische Polyklinik; Berliner Psychoanalytisches Institut; Germany; International Psychoanalytic Association; *Internationale Zeitschrift für (ärztliche) Psychoanalyse*; Israel; Lay analysis; "Lines of Advance in Psycho-Analytic Therapy"; Secret Committee; Technique with adults, psychoanalytic; Training analysis.

### Bibliography

- Draper, Theodore. (1988, April 14). The mystery of Max Eitingon. *New York Review of Books*, 35 (6), 32–43.
- Eitingon, Max. (1912). Genie, Talent und Psychoanalyse. *Zentralblatt für Psychoanalyse*, 2, 539–540.
- Eitingon, Max. (1914). Gott und Vater. *Imago*, 3, 90–93.
- . (1915). Ein Fall von Verlesen. *Internationale Zeitschrift für Psychoanalyse*, 3, 349–350.
- . (1922). Zur psychoanalytischen Bewegung. *Internationale Zeitschrift für Psychoanalyse*, 8, 103–106.
- . (1923). Report of the Berlin Psychoanalytical Poly-clinic. *Bulletin of the International Psychoanalytical Association*, 4, 254.
- Moreau Ricaud, Michelle. (1992). Max Eitingon (1881–1943) et la politique. *Revue internationale d'histoire de la psychanalyse*, 5, 55–69.

## ELASTICITY

"The Elasticity of the Psychoanalytic Technique" is the title of a paper that Sándor Ferenczi gave to the Budapest Psychoanalytic Society, and which was first published in 1928. In essence he described the procedure he had introduced in his paper on the "contra-indications of the active technique" (1926), in which he recommended using relaxation to reduce tension in certain difficult cases. In two other articles from the same period ("Family Adaptation to the Child" and "The Problem of the End of Analysis") he dealt with difficulties in the educational environment. The question became one of how far the idea of elasticity could be taken. In 1967, Michael Balint would write on Ferenczi's problem, "His earlier experiences had familiarized him with two models: one was the classic technique with its objective and benevolent passivity, and apparently imperturbable and unlimited patience; the other was the active technique with its well-directed interventions founded on attentive observation and empathy."

In the 1928 paper, Ferenczi developed the technical importance of tact in deciding on the right moment to

communicate to the patient any conjectures the analyst may have made, "based essentially on the dissection of our own Self." He stressed the notion of modesty, which should be "the expression of the acceptance of the limits to our knowledge," and to this end he preferred from the beginning of treatment to adopt a rather pessimistic attitude, in order to avoid creating enthusiastic confidence in the future patient, a confidence that often camouflaged "a healthy dose of distrust." Nothing could be more harmful, he continued, "than the attitude of a schoolmaster or an authoritarian doctor." He thus spoke of *Einfühlung* (feeling-with, empathy) as of a rule, from which he deduced the necessity, for the analyst, of developing "a rigorous control of his own narcissism and intense vigilance with regard to his own affective reactions." Analysts would have to "guess when the patient's esthetic sentiments have been offended by our own attitude" and, supporting this displeasure, behave like those little "culbutos" (small figures with lead ballast in their base that always return to a vertical position). Ferenczi proposed "a perpetual oscillation between feeling-with, self-observation and judgment activity."

He concluded this reflection on the counter-transference with a "metapsychology of the technique," denouncing the "fanaticism of interpretation as an infantile disease of analysis" because, in order for patients to become free of all emotional binds, they must "abandon, at least provisionally, all sorts of superegos, including that of the analyst." This position borders on "a demand for elasticity in the analysts themselves," a "metapsychology of the analysts." This then makes it absolutely essential to comply with the second rule of psychoanalysis, already problematic at the time, that analysts must themselves be analyzed.

PIERRE SABOURIN

See also: Active technique; Ferenczi, Sándor; Tact; Technique with adults, psychoanalytic.

### Bibliography

- Balint, Michael. (1967). Introduction. In Sándor Ferenczi, *Oeuvres complètes* (Vol. 4). Paris: Payot, 1982.
- Ferenczi, Sándor. (1926). Contre-indications de la technique active. In his *Oeuvres complètes* (Vol. 3, pp. 389–428). Paris, Payot.

———. (1926). Le problème de l'affirmation du déplaisir. In his *Oeuvres complètes* (Vol. 3, pp. 389–428). Paris: Payot

———. (1928). The elasticity of psycho-analytic technique. In M. S. Bergmann and F. R. Hartman (Eds.), *The evolution of psychoanalytic technique*. New York: Basic Books.

## ELEMENTI DI PSICOANALISI

Published by Ulrico Hoepli (Milan, Italy) in 1931, Edoardo Weiss's work was the first complete and accurate exposé of psychoanalysis in Italy. Freud spoke approvingly of the work of his Italian disciple when he wrote in his preface that the book recommended itself to anyone who was able to appreciate the "seriousness of a scientific effort," the "honesty of the researcher," and the "skills of the teacher." Some chapters were translated into German in the *Psychoanalytische Bewegung*. A second edition appeared in 1932, and a third in 1936. The most recent edition was published in 1985.

The book is based on five lectures given by Weiss in Trieste, Italy, at the initiative of the local medical association in the spring of 1930. He covered the following subjects: (1) the nature of psychoanalysis and the concept of the id and unconscious inhibition, (2) symbolism, (3) the origin of the superego and social and religious sentiments, (4) drive theory, (5) psychic systems. In an appendix Weiss added a glossary of basic psychoanalytic vocabulary in Italian, with approximately ninety terms accompanied by their German equivalent. This small dictionary was the first, and for a long time the only, instrument of its kind available in Italy.

Although Weiss attempted to summarize Freud's thought, he did not simply reproduce it passively. He introduced a conceptual neologism, the "inhibitory id," to refer to the oldest part of the superego and the feeling of unconscious guilt that accompanies it. The problem of unconscious guilt appears clearly in the fourth lecture, where he describes Freud's death impulse and refers to Ernst Federn's statement concerning the intermediate character of the life and death drive.

The *Elementi* was a qualitative leap over the handful of works on psychoanalysis available in Italy until then, works that were often badly informed and tentative. Therein lies its historical importance.

ANNA MARIA ACCERBONI

See also: Italy; Weiss, Edoardo.

## Source Citation

Weiss, Edoardo. (1931). *Elementi di psicoanalisi*. Milan: Ulrico Hoepli.

## Bibliography

Accerboni, Anna Maria. (1985). Un'opera che si raccomanda da sé. In Edoardo Weiss, *Elementi di psicoanalisi*. Pordenone, Italy: Studio Tesi.

## ELISABETH VON R., CASE OF

"Fräulein Elisabeth von R." is the pseudonym Freud gave to Ilona Weiss, a young woman of Hungarian origin, whose case is described in the *Studies on Hysteria* (1895d) and whom he treated in the fall of 1892 and July 1893. The third daughter in a well-to-do Hungarian family, Elisabeth von R. was twenty-four years old when Freud treated her in the autumn of 1892 for pains in her legs and difficulties walking, problems she had been experiencing for two years. He confirmed the diagnosis of hysteria that had been made and noted that "if one pressed or pinched the hyperalgesic skin and muscles of her legs, her face assumed a peculiar expression, which was one of pleasure rather than pain. She cried out—and I could not help thinking that it was as though she was having a voluptuous tickling sensation—her face flushed, she threw back her head and shut her eyes and her body bent backwards" (1895d, p. 137).

After an initial period of four weeks during which he prescribed electrical treatments, he suggested to her the use of a cathartic cure that "turned out, however, to be one of the hardest that I had ever undertaken" (1895d, p. 138). Resistant to hypnosis, the patient stretched out with her eyes closed but was able to move, open her eyes, and sit up. Freud then applied his "concentration technique," the same one he was using on another patient of his at the time, Miss Lucy R.

It was this that persuaded Freud that she was hiding a secret, but her initial remarks had no effect in spite of their dramatic nature. Her family history was characterized by heart disease and the death of her father, whom she deeply loved, for whom she "took the place of a son and a friend with whom he could exchange thoughts" (1895d, p. 140). Freud understood that her illness had begun with pains in her legs, which first occurred while she was caring for her sick father, even

though she was not aware of them until two years after his death. The sickness and death of her sister, who was also afflicted with heart disease aggravated by pregnancy, followed by a quarrel between her brothers-in-law, had coincided with the two years of the development of her illness.

During this period of the treatment, she repeated to Freud that she was not doing better in spite of her confession and Freud remarked that “when she looked at me as she said this with a sly look of satisfaction at my discomfiture, I could not help being reminded of old Herr von R.’s judgment about his favorite daughter—that she was often ‘cheeky’ and ‘ill-behaved’” (1895d, p. 141).

An improvement occurred when she herself provided the source of her hysterical conversion: Her pains began at the spot on her thigh where, every morning, her father placed his inflamed leg so she could change his bandages. From then on “her painful legs began to ‘join in the conversation’ during our analyses” (1895d, p. 141), a period of abreaction when, Freud writes, “I sometimes followed the spontaneous fluctuations in her condition; and I sometimes followed my own estimate of the situation when I considered that I had not completely exhausted some portion of the story of her illness” (1895d, p. 149). He then experimented with the phenomenon that would soon modify his conception of psychotherapy: “In the course of this difficult work I began to attach a deeper significance to the resistance offered by the patient in the reproduction of her memories and to make a careful collection of the occasions on which it was particularly marked” (1895d, p. 154). It was on her account that he used publicly for the first time (this information is found six months later in Draft H, dated January 24, 1895, in 1950a) a key theoretical concept: “it can be shown with likelihood that complete conversion also occurs, and that in it the incompatible idea has in fact been ‘repressed’ [*verdrängt*], as only an idea of very slight intensity can be.”

In the spring of 1893 a sharp pain reoccurred when she heard, in a room adjacent to Freud’s office, her brother-in-law who had come to pick her up. This enabled Freud to track down her “secret”—she had fallen in love with her brother-in-law. She had grown closer to him as a result of her sister’s illness, and upon her death was unable to repress the thought that he was now free. In spite of his patient’s denials, Freud insists on, and goes so far as to solicit the testimony of

the young woman’s mother, who confirmed that she had suspected as much. The treatment concluded in July 1893 with the appeal to the mother for assistance. This was to have repercussions later on, since the daughter rebelled and refused to see Freud again because he had betrayed her secret.

Freud, confident in his treatment, notes with pleasure: “In the spring of 1894 I heard that she was going to a private ball for which I was able to get an invitation, and I did not allow the opportunity to escape me of seeing my former patient whirl past in a lively dance” (1895d, p. 160). When he prepared the case study for the *Studies on Hysteria*, he learned from Wilhelm Fliess (to whom he had given it to read) on July 14, 1894, that she had just gotten engaged.

Elisabeth von R., if we are to believe her daughter’s revelations, told the story somewhat differently. “She described Freud as ‘just a young, bearded nerve specialist they sent me to. He had tried ‘to persuade me that I was in love with my brother-in-law, but that wasn’t really so.’ Yet, her daughter adds, Freud’s account of her mother’s family history was substantially correct, and her mother’s marriage was happy.” (Gay, p. 72).

It was in this context that Freud wrote, “This was my first complete analysis of a hysteria. It allowed me for the first time, with the help of a method that I would later use as a technique, to eliminate psychic material in layers, which I like to compare to the technique of unearthing a buried city” (1895d, p. 139). Yet the treatment is less important historically for the spectacular discovery of the “love secret” that is revealed than because it demonstrates to Freud the mechanism of conversion, his link to a father with whom he identifies without yet drawing the relevant conclusions, and the resistance he must overcome through belief in his method, in order to eliminate, beyond the relative freedom of association he allows his patient, through speech, layer by layer, the psychic material that blocks the return of repressed memories.

ALAIN DE MIJOLLA

See also: Cathartic method; Erotogeneity; Phlyogenesis; Resistance; *Studies on Hysteria*.

### **Bibliography**

Ellenberger, Henri F. (1970). *The discovery of the unconscious: The history and evolution of dynamic psychiatry*. New York: Basic Books.

Freud, Sigmund. (1950a [1887–1902]). Extracts from the Fliess papers. *SE*, 1: 173–280.

Freud, Sigmund, and Breuer, Josef. (1895d). Studies on hysteria. *SE*, 2: 48–106.

Gay, Peter. (1988). *Freud: A life for our time*. London-Melbourne: Dent.

## ELLENBERGER, HENRI FRÉDÉRIC (1905–1993)

Henri Frédéric Ellenberger, physician, psychiatrist, and historian of psychoanalysis, was born in Nanolo, Rhodesia, on November 6, 1905, and died in Montreal on May 1, 1993. He was born into a family of Swiss protestants. His father, Victor Ellenberger, a naturalist and anthropologist, was a member of the Société des missions évangéliques de Paris (Society of Evangelical Missions of Paris), and his mother, Évangéline Christol, was the daughter of a pastor.

Ellenberger completed his medical studies in Strasbourg, France, and it was there that he was introduced to historical research. He moved to Paris to specialize in psychiatry and, after being appointed a resident in psychiatry, worked at the Sainte-Anne Hospital alongside Henri Ey. In November 1930 he married Esther von Bachst, a Russian émigrée with a passion for zoology, and they had four children.

Ellenberger settled in Poitiers, but because he was not a naturalized French citizen, in 1941 he emigrated to Switzerland. He worked as a psychiatrist at the Breitenau Hospital in Schaffhausen and was part of the Jung Circle in Zurich, through which he met Carl Gustav Jung. In 1950 he began a training analysis with Oskar Pfister, who was then seventy-seven years old. In 1952 he traveled to the United States, met Karl Menninger, and was appointed professor at the Menninger School of Psychiatry in Topeka, Kansas. In 1953 he encountered immigration problems, and in 1959 he moved to Montreal, where he became a professor of criminology at McGill University.

In 1962 he began the historical research that resulted in the publication of *The Discovery of the Unconscious: The History and Evolution of Dynamic Psychiatry* in 1970. In contrast with the oral tradition of the history of psychoanalysis and Ernest Jones's biography of Sigmund Freud, and in spite of the paucity of documentation, Ellenberger's work provided a

detailed history of the theories and practices that, since antiquity, made use of the forces of what would come to be theoretically designated as the unconscious. Ellenberger traced the "dynamic" tradition in psychiatry back to Franz Mesmer. In this tradition he placed Jean Martin Charcot, Pierre Janet, Sigmund Freud, Alfred Adler, and Carl Gustav Jung. Ellenberger wanted to show that the hagiographies of Freud were mistaken: Freud did not receive some heavenly illumination. Rather, his theories are only one link, albeit an important one, in a tradition that included sorcerers, shamans, the Catholic confession, Alfred Schopenhauer, and Gustav Fechner.

After learning about Ola Andersson's discovery of the true story of Emmy von N., which Ellenberger published, he continued working as a historian of psychoanalysis, intent on removing the doubts and omissions that littered a historiography divided between worship and calumny. His position has been judged by a number of psychoanalysts as unfavorable to Freud and psychoanalysis, for it served as a point of departure for several openly hostile research efforts. Although his attitude was seen as largely negative, especially in Freudian circles, where his work received a poor reception, he remained a dedicated researcher, conscious of establishing the first principles of a psychiatric historiography that stood in marked contrast to a cult of hero worship.

ALAIN DE MIJOLLA

*See also:* Anna O., case of; Emmy von N., case of; Moser-von Sulzer-Wart, Fanny Louise; Pappenheim, Bertha.

### Bibliography

Ellenberger, Henri Frédéric. (1970). *The discovery of the unconscious: The history and evolution of dynamic psychiatry*. New York: Basic Books.

———. (1972). L'histoire d'Anna O.: étude critique avec documents nouveaux. *Évolution psychiatrique*, 37 (4), 693–717.

———. (1977). L'histoire d'Emmy von N. *Évolution psychiatrique*, 42 (3/1), 519–540.

Micale, Mark S. (1993). Henri Ellenberger and the origin of European psychiatric historiography. In Henri Ellenberger, *Beyond the unconscious: essays of Henry F. Ellenberger in the history of psychiatry*. Princeton, NJ: Princeton University Press 1993.

Roudinesco, E. (1994). Présentation. In Henri F. Ellenberger, *Histoire de la découverte de l'inconscient*. Paris: Fayard.

## EMBIKOS, ANDREAS (1901–1975)

Andreas Embirikos, a poet and psychoanalyst, was born on September 2, 1901, in Braila, Romania, and died in 1975 in Athens. His father's family was originally from the island of Andros. His mother was born in Russia. He had three brothers. Shortly after his birth, the family settled on the island of Syros, then in Athens, where Embirikos completed his secondary education and enrolled at the University of Athens to study philosophy.

Between 1926 and 1931 he lived in Paris. Interested in psychoanalysis, he underwent analysis with René Laforque and made contact with the surrealists. He became friends with André Breton. After his return to Athens in 1931, he worked for a while as director in the shipping company that belonged to his father, but he soon left his position to devote his life to poetry and psychoanalysis.

Embirikos, the first psychoanalyst in Greece, was actively involved in psychoanalysis from 1935 until the end of 1950. In 1947 he was one of the founding members of the first psychoanalytic group in Greece and in 1950 was made a member of the Paris Psychoanalytic Society.

His friends referred to Embirikos as “brilliant and unlike anyone else.” One might assume that he combined the glory of the poet with the perseverance of the psychoanalyst, but this was not the case. In 1951, believing he was under the threat of a lawsuit for practicing therapy without a medical license, Embirikos closed his psychoanalytic practice. He had been badly treated by the police at the end of the civil war and now believed he had become a target of the medical establishment. He left for Paris.

Two years later Embirikos returned to Greece to devote himself to his poetry. He was a prolific poet and produced work of high quality. His poetry was a broad erotic fresco with occasional references to psychoanalysis. His only psychoanalytic publication appeared in 1950: “Un cas de névrose obsessionnelle avec éjaculations précoces.” Embirikos married twice. He died at the age of seventy-four from lung cancer.

ANNA POTAMIANOU

*See also:* Greece.

### **Bibliography**

Embirikos, Andréas. (1950). Un cas de névrose obsessionnelle avec éjaculations précoces. *Revue française de psychanalyse*.

Kourias, Eri, and Kourias, Georges. (1984). *Un cas de pratique psychanalytique relié à une errance hyperréaliste: La psychanalyse et la Grèce*. Athens: Société d'études de la culture néohellénique et de l'éducation.

*Revue Hartis*. (1985). A series of articles dedicated to Andréas Embirikos. 17–18.

Tzavaras, Athanase. (1981). Andréas Embirikos et la psychanalyse. *Bulletin de la Société d'études de la culture néohellénique et de l'éducation*, 5.

Zavitzianos, Georges. (1981). Andréas Embirikos, psychoanalyst. *Le mot*, 20.

## EMDEN, JAN EGBERT GUSTAAF VAN (1868–1950)

Jan van Emden, Dutch physician and psychoanalyst, was born in Paramaribo, Surinam, on August 5, 1868, and died in the Hague on March 23, 1950, aged 82. He was trained as a medical doctor at the University of Leiden and received his degree in 1896 for his dissertation “Bijdragen tot de kennis van het bloed” (Contributions to knowledge of the blood). Van Emden met Freud in 1910 when the latter was vacationing in Noordwijk, the Netherlands, and they subsequently became good friends. During the First World War van Emden functioned as intermediary between Freud and Ernest Jones, who was instrumental in introducing psychoanalysis in England, and also arranged for Anna Freud's return to Vienna.

In 1912, after a short training with Freud, van Emden established himself in the Hague as one of the first practicing psychoanalysts there. He was a member of the Vienna Psychoanalytic Society from 1911 to 1914. One of the founders of the Nederlandsche vereeniging voor psycho-analyse (Dutch society for psychoanalysis) in 1917, he was chairman from 1919–1929. In 1934 he became president after the split of the society and the founding of the Vereeniging van psychoanalytici in Nederland (New Dutch society of psychoanalysis).

Van Emden's contributions to psychoanalysis are modest. He was a regular participant in the Congresses of the International Psychoanalytical Association, at which he presented four papers (in 1913, 1918, 1924, and 1925). As a member of the Dutch society for psy-

choanalysis, he gave a number of presentations. He translated two works of Freud into Dutch: *Five Lectures on Psycho-analysis* and *Thoughts for the Times on War and Death*.

JAAP BAR AND CHRISTIEN BRINKGREVE

See also: Netherlands.

### Bibliography

- Brinkgreve, Christien. (1984). *Psychoanalyse in Nederland: een vestigingsstrijd*. Amsterdam: Arbeiderspers.
- Van Emden, Jan. (1912a). *Over psycho-analyse*. Leiden, Netherlands: Van Doesburgh. (Translation of Sigmund Freud, *Five lectures on psycho-analysis*.)
- . (1912b). Selbstbestrafung wegen abortus. *Zentralblatt für Psychoanalyse*, 3, 647.
- . (1917). *Beschouwingen over oorlog en dood*. Leiden, Netherlands: Van Doesburgh. (Translation of Sigmund Freud, *Thoughts for the times on war and death*.)
- . (1925). Zur Bedeutung der Spinne in Symbolik und Folklore. *Internationale Zeitschrift für Psychoanalyse*, 11, 512–513.

---

## EMMA, CASE OF. See Eckstein, Emma

---

## EMMY VON N., CASE OF

Frau Emmy von N. was the pseudonym given by Sigmund Freud in the *Studies on Hysteria* to his patient Fanny Moser, who was born Fanny Sulzer-Wart in 1848 and died in 1925. In her autobiography her daughter Mentona speaks of “the famous professor that [her] mother went to see in Vienna” (referring to either Josef Breuer or Rudolf Chrobak), who soon referred the patient to “his first assistant,” Doctor Sigmund Freud. “He was small and thin, his hair was blue-black, large black eyes, he looked timid and very young. He made a profound impression on me.” (in Ellenberger, Henri F., 1977).

On May 1, 1889, during her first visit, Freud described his meeting with this forty-year old woman, which would have made her seven years younger than Freud: “This lady, when I first saw her, was lying on a sofa with her head resting on a leather cushion. She still looked young and had finely-cut features, full of

character. Her face bore a strained and painful expression, her eyelids were drawn together and her eyes cast down; there was a heavy frown on her forehead and the naso-labial folds were deep. She spoke in a low voice as though with difficulty and her speech was from time to time subject to spastic interruption amounting to a stammer.” He also noted the clicking sound she made with her tongue when upset.

This intelligent but very anxious patient provided him, without his awareness, with a premonitory indication of the future therapeutic framework when she cried out: “Keep still!—Don’t say anything!—Don’t touch me!” She made use of this incantatory remark on several occasions, whenever she was frightened by some particularly terrifying memory, but Freud, after ten days of therapy, decided to eliminate it through the use of suggestion, which he succeeded in doing.

His treatment was consistent with customary practice, which consisted in her case of a stay at a clinic, separated from her two daughters, with whom she did not get along. Freud prescribed warm baths and massages twice a day. The patient was completely accessible to hypnosis and, in this state, recounted the origin of the delusional fears and visual hallucinations (rats, frogs) from which she suffered, retracing them to her childhood. “My therapy consists in wiping away these pictures, so that she is no longer able to see them before her. To give support to my suggestion I stroked her several times over the eyes.”

The systematic pursuit of her memories enabled Freud to state that the case of Emmy von N. was the first in which he had employed the “cathartic method.” One day, when she was irritated, the patient also made a remark whose practical consequences Freud did not fail to draw. She asked him to stop interrupting her with questions and to allow her to speak freely. At the time Freud still played the role of the grand magician, the antithesis of the future psychoanalytic attitude, and his authority was necessary to erase the patient’s pathogenic memories through the process of suggestion.

It is interesting to note that there exists an 1894 note Freud added to the case history—this still a year before the dream of the injection given to Irma—in which he indicates that he wrote down his own dreams and traced them back to two factors: “(1) to the necessity for working out any ideas which I had only dwelt upon cursorily during the day—which had only been

touched upon and not finally dealt with; and (2) to the compulsion to link together any ideas that might be present in the same state of consciousness. The senseless and contradictory character of the dreams could be traced back to the uncontrolled ascendancy of this latter factor.” Although here is evident a clear glimpse of clinical intuitions that, in retrospect, appear anticipatory, at this point Freud’s therapy continues to be a blend of such “purgative retellings” and electrotherapy.

Freud’s notes stop on June 20 and Emmy von N. apparently left, quite improved, for her château in Switzerland. Freud visited her on July 18, traveling along the road to Nancy, where he was to meet Hippolyte Bernheim.

In January 1890 Emmy had a relapse. She went to see Breuer, complaining of nervous disturbances from which her daughter was suffering and blaming Freud and Chrobak. She was so agitated that they had her admitted to a sanatorium, from which she ended up escaping with the help of a woman friend. No doubt she came to represent one of the cases Freud referred to later to explain why he abandoned hypnosis: “On one occasion a severe condition in a woman, which I had entirely got rid of by a short hypnotic treatment, returned unchanged after the patient had, through no action on my part, got annoyed with me; after a reconciliation, I removed the trouble again and far more thoroughly; yet it returned once more after she had fallen foul of me a second time.” (1916–17a [1915–17])

In May 1890, the anniversary of his first therapy, she came back to see Freud for additional therapy, which lasted eight weeks—until July. She felt better but suffered from mental confusion, “storms in her head,” and insomnia, and the clicking tic and stammering had reappeared. Freud analyzed the origin of the return of these symptoms and again succeeded in eliminating them.

In the spring of 1891 Freud saw Emmy von N. at her home, where he stayed for several days to help resolve the problems she was having with her older daughter. She was feeling better but Freud resumed the therapy to eliminate her phobia of train travel. Because she claimed to be less docile than before, that is less attached to him, he reestablished his authority and his position through his little drama of being a hypnotist, which he exposed with such candor that it is obvious he was entirely unaware of his unconscious motives.

In an addendum that dates from 1924, Freud reports that, several years after this last visit, he met a doctor with whom she had behaved as she had with him: easy to hypnotize in the beginning then irritable and subject to relapses: “It was a genuine instance of the ‘compulsion to repeat.’” He added that around 1920 her elder daughter had written him to request a report, because she wanted to initiate a lawsuit against this “cruel tyrant” who had chased away her two children.

It has become fashionable to question Freud’s diagnoses, and the case of Emmy von N. is no exception: melancholia, schizophrenia, nervous tics, the neurosis of a rich and idle woman, according to the various reports. Although Anna O. alone was successfully treated and managed to create an exemplary life for herself, Henri F. Ellenberger has remarked that it was Emmy’s daughter, Mentona Moser, who benefited from the intellectual and social emancipation her mother never achieved.

ALAIN DE MIJOLLA

See also: Andersson, Ola; Cathartic method; Ellenberger, Henri Frédéric; Free association; Moser-von Sultzer-Wart, Fanny Louise; Psychoanalytic treatment; *Studies on Hysteria*.

### Bibliography

- Andersson, Ola. (1962). *Studies in the prehistory of psychoanalysis*. Stockholm: Svenska Bokförlaget.
- Ellenberger, Henri F. (1970). *The discovery of the unconscious: The history and evolution of dynamic psychiatry*. New York: Basic Books.
- . (1977). *The story of “Emmy von N.”: A critical study with new documents*. Princeton: Princeton University Press, 1993.
- Freud, Sigmund. (1916–17a [1915–17]). Introductory lectures on psycho-analysis. Parts I & II, *SE*, 15–16.
- Micale, Mark S. (Ed.). (1993). *Beyond the unconscious. Essays of Henri F. Ellenberger in the History of Psychiatry*. Princeton, NJ: Princeton University Press.

---

## EMOTION

The word *emotion* is derived from the Latin *emovere*, “to set in motion.” It initially referred to the idea of physical movement and then assumed a figurative meaning associated with mental movement.

The term is infrequently used in psychoanalysis, where the term *affect*, derived from German *Affekt*, is preferred. Sigmund Freud, however, in a text written in French in 1895, used the expression “état émotif” (“emotive state”) to designate what was translated in the German editions as *Affekt*. It is with the theoretical developments associated with Kleinian psychoanalysis that the term emotion reappeared. The reasons for the change are significant.

Freudian metapsychology is centered on the study of the mental apparatus, which is considered, if not as an isolated entity, at least as one that can be isolate. In the Freudian model the mental apparatus is charged with drives, whose effects—affect and representation—are observable. Affect corresponds to the quantitative aspects, and mental representations correspond to the qualitative aspects of the drives. Positive affects accompany the satisfaction of drives, negative affects accompany the state of tension within the mental apparatus (pleasure/unpleasure principle). The object of satisfaction, that is, the object that triggers the discharge of the impulse, is contingent, vicarious. For Daniel Widlöcher, the affect refers to internal regulatory functions of the mental apparatus: a discharge of impulses and signals intended to provide information to the mental apparatus, as Freud suggested in his second theory of anxiety, and that emotion adds a third reference, that of communication with the external object, “a modality of expression intended to inform others of a particular situation, laden with value for the subject.”

It should come as no surprise therefore that the theories assigning greater importance to object relations have given a central place to the concept of emotion. Compared to affect, it contains levels of additional complexity, because it is a means of communicative exchange between self and other, through its behavioral (especially facial) expressions, which have been extensively studied by specialists in development and cognitive function, and because it refers to nuanced qualitative aspects rather than simply quantitative aspects combined with a positive or negative valence.

Melanie Klein insisted on the extreme nature of the baby’s emotions at the start of its extra-uterine existence, associated with love and hate relations directed at the (partial) object in what she called the “paranoid-schizoid position.” Later, when the infant achieves the “depressive position,” emotions become more nuanced, hate is tinged with guilt, love with ambivalence. Wilfred Bion gave the concept of emo-

tion an essential role in his description of the intrapsychic world as a world of relations between internal or interiorized objects. For Bion the links between internal objects are emotional links, just as the links between the subject and its external objects are emotional in nature. He chose three types of emotional links: these correspond to love relations (L link = love), hate relations (H link = hatred), and knowledge relations (K link = knowledge). The first two, L and H, are emotional links; these are unstable and associated with splitting. The K link is the psychoanalytic link par excellence and has the advantage of stability. It does indeed involve an emotional link, in the sense that it corresponds to an emotion associated with uncertainty and the tension experienced in the face of the unknown in anticipation of meaning. Psychoanalytic therapy develops K links.

DIDIER HOUZEL

*See also:* Concept; Darwin, Darwinism, and psychoanalysis; Shame; Links, attacks on; Love-Hate-Knowledge (L/H/K links); Memories; Paranoid-schizoid position; Quota of affect; *Unconscious as Infinite Sets: An Essay in Bi-Logic, The*.

### **Bibliography**

- Bion, Wilfred. R. (1962). A theory of thinking. *International Journal of Psycho-Analysis*, XLIII, 4–5; in *Second Thoughts*, London: Heinemann, 1967.
- Freud, Sigmund. (1895c [1894]). Obsessions and phobias: their psychical mechanism and their aetiology. *SE*, 3: 69–82.
- Klein, Melanie. (1952). Quelques conclusions théoriques au sujet de la vie émotionnelle des bébés. In M. Klein, P. Heilmann, S. Isaacs, and J. Riviere (Eds.), *Developments in psychoanalysis* (pp. 187–253). London: Hogarth Press.
- Widlöcher, Daniel. (1992). De l’émotion primaire à l’affect différencié. In P. Mazet and S. Lebovici (Eds.) *Émotions et Affects chez le bébé et ses partenaires* (pp. 45–55). Paris: Eshel.

---

## **EMPATHY**

*Empathy* is the capacity for concrete representation of another person’s mental state, including the accompanying emotions. The English term is a translation of



the German word *Einfühlung*, coined in 1873 by the German philosopher Robert Vischer. Vischer used it to refer to a modality of aesthetic sensibility. In contrast to the theory that categorized objective qualities inherent in the object as beautiful, Vischer described the subjective nature of an experience where beauty resulted from the projection of human sensibilities onto natural objects. Theodor Lipps (1851–1914), a philosopher who taught in Munich, gave *empathy* a broader, psychological range, attributing to this form of intuition access to knowledge of another's subjectivity. It is in this sense, and most likely from reading Lipps, that Sigmund Freud used the term, which was still uncommon at the time.

Freud used the term in a number of his essays. He used it for the first time in *Jokes and Their Relation to the Unconscious* (1905) in relation to the economic explanation of the pleasure associated with humor. He returned to it several times to refer to a form of intuitive understanding of others essential to psychoanalytic communication. For Freud, however, the term had no specific psychoanalytic meaning but rather a general psychological meaning, moreover, one that was still poorly understood. This is likely one reason that James Strachey did not feel the need to propose a single English translation; the other reason being that the term *empathy*, which had already been proposed in 1909 by the psychologist Edward Bradford Titchener and taken up by Ernest Jones, did not generate much enthusiasm from Strachey. In France the term *empathie* came back into use following the publication of the translation of Freud's works under the direction of Jean Laplanche. This resulted in the misunderstanding of a precise concept for Freud, in particular, in his correspondence with Sándor Ferenczi.

The concept did not become important until 1960, when Ralph Greenson studied it, no doubt influenced by the interest in countertransference that occurred after the work of Heinrich Racker and Paula Heimann. Since then a number of studies have emphasized the importance of the concept for communication during analysis. There have been some reservations arising from what was felt to be the somewhat obscure and slightly irrational nature of the phenomenon. Other authors (Buie, 1981; Widlöcher, 1993) have tried to specify the psychological mechanisms operating in this complex form of intuitive understanding, specifically emphasizing the role of identification and inference.

From the metapsychological perspective, the debate continues between those who assign empathy a decisive role in the discovery of the unconscious and the therapeutic activity of the psychoanalyst (Heinz Kohut) and those who deny that empathy can play a role in identifying the unconscious.

DANIEL WIDLÖCHER

*See also:* Counter-identification; Counter-transference; Elasticity; Greenson, Ralph; Identification; Kohut, Heinz; Lebovici, Serge; Sindel Charles; Projective identification; Self, the.

### **Bibliography**

- Buie, Dan H. (1981). Empathy: Its nature and limitation. *Journal of the American Psychoanalytic Association*, 29, 281–307.
- Freud, Sigmund. (1905). Jokes and their relation to the unconscious. *SE*, 8: 1–236.
- Greenson, Ralph R. (1960). Empathy and its vicissitudes. *International Journal of Psycho-Analysis*, 41, 418–424.
- Widlöcher, Daniel. (1993). L'analyse cognitive du silence en psychanalyse: Quand les mots viennent à manquer. *Revue internationale de psychopathologie*, 12, 509–528.

### **Further Reading**

- Kohut, Heinz. (1959). Introspection, Empathy, and psychoanalysis. *Journal of the American Psychoanalytic Association*, 7, 459–483.
- Orange, Donna. (2002). There is no outside: Empathy and authenticity in psychoanalytic process. *Psychoanalytical Psychology*, 19, 686–700.
- Pigman, George W. (1995). Freud and the history of empathy. *International Journal of Psychoanalysis*, 76, 237–256.
- Schwaber, Evelyn. (1981). Empathy: A mode of analytic listening. *Psychoanalytical Inquiry*, 1, 357–392.
- Shapiro, Theodore. (1981). Empathy: A critical re-evaluation. *Psychoanalytical Inquiry*, 1, 423–448.
- Shaughnessy, Patrick. (1995). Empathy, working alliance: Mistranslation of Freud's "einfühling". *Psychoanalytical Psychology*, 12, 221–232.

---

## **EMPTY FORTRESS, THE**

The saga of *The Empty Fortress* began in 1952. Two years earlier, in his book *Love Is Not Enough*, Bruno

Bettelheim had reported his first findings concerning the disturbed children in the school he had directed in Chicago since 1944. That book had captured the interest of thousands of Americans. The popularization of psychoanalysis was in full bloom in the United States, and psychiatric research was very much in fashion. High hopes seemed in order: Americans had defeated Hitler; surely they could overcome madness. There was no shortage of research funding, and in 1956, ahead of Anna Freud's Hampstead Nurseries, Bettelheim received a five-year Ford Foundation grant of \$342,500 to finance his study of autism. *The Empty Fortress* is based in part on the reports that Bettelheim submitted to the Ford Foundation each year.

It was hardly automatic that autistic children were referred to Bettelheim's Orthogenic School, which was run like a family home and where diagnostic labels and psychiatric drugs were forbidden. "If you give them drugs," Bettelheim wrote, the children "cannot believe that you really want them to be the way they would like to be. If you manipulate their bodies like that, how could they fail to think that you also want to manipulate their minds?" (personal communication, 1980). After a great deal of discussion with his colleagues, in 1950–1951 Bettelheim finally received a few "children who don't speak" (as their playmates would call them), children whose pathology Margaret Mahler distinguished from other forms of infantile psychosis at the 1951 Congress of the International Psychoanalytical Association in Amsterdam.

The first sentence of Bettelheim's book sums up his credo: "Much of modern psychology seeks to know about others; too much of it, in my opinion, without an equal commitment to knowing the self. But I believe that knowing the other—which is different from knowing about the other—can only be a function of knowing oneself" (p. 3). This was the foundation on which he trained (sometimes very roughly) the educators in his school. The sentiment also illustrates the secret of Bettelheim's remarkable clinical intuition.

While observing the wolf-child-like behavior of little Anna, Bettelheim writes, he was struck by the parallel between his own experience of concentration camps and his therapeutic work (pp. 7–8). Anna had been born in Poland during the Second World War to Jewish parents who did not get along but were obliged to live together, holed up in an earthen cellar and afraid to make the slightest sound. By the age of ten, the little girl, now mute, had almost killed her young brother several times.

No treatment facility would keep her more than a few hours; even a psychiatric hospital had been unable to cope with her for more than a month. In her eyes Bettelheim recognized a terror that he himself could never forget—the terror of someone placed in an environment that seeks to destroy him without his knowing why or whether he will ever escape. Bettelheim had been evoking this "extreme situation" since his article on Buchenwald (1943). In *The Empty Fortress* he defined it, for the first time, as a situation "when we ourselves respond to an external danger—real or imagined—with inner maneuvers that actually debilitate us further" (p. 77). Later he added that in the face of an extreme situation, the individual rejects his normal personality because his ordinary reactions are now liable to place his life in danger (1980, pp. 11, 116). Convinced that, however senseless little Anna's actions might seem, they in fact had meaning, Bettelheim studied her symptoms closely enough to be able to make the striking claim that he was describing autism as if from the subject's point of view.

Traditionally, autistic subjects are characterized in terms of their shortcomings. In *The Empty Fortress*, by contrast, the children are alive and active, and each of their gestures is understood as an attempt to reduce their suffering. The three case histories that Bettelheim recounted in detail, those of Laurie, Marcia, and Joey (the "boy-machine" who could not move or even say hello without first "plugging himself in" with an imaginary cord to an equally imaginary wall-socket), make such a powerful impression on readers that they often forget the first part of the book, "The world of encounter," in which Bettelheim gives an account of the birth and decline of the self.

The first hundred or so pages of the book, permeated with notions of the "self psychology" then being developed by Heinz Kohut, are nevertheless the strongest ever written by Bettelheim on mental illness. They even prompted Donald Winnicott to make the following somewhat ruffled remark: "I find him difficult to read simply because he says everything and there is nothing to be said that one could be certain has not been said by him. But I must read him because he can be exactly right, or more nearly right than other writers. This applies especially to his opening chapters in *The Empty Fortress*" (1989, p. 246n).

This book made Bettelheim famous worldwide; it also defined him narrowly as a specialist of autism. He was partly responsible for this, for he inflated his suc-

cess rate to help quiet his behaviorist opponents. His overriding priority was to give voice to the mental suffering of his patients and remind the medical world of the respect it owed to such suffering. *The Empty Fortress* was in effect a clinical sourcebook, and it had a decisive effect on the evolution of institutional attitudes towards autism.

NINA SUTTON

See also: Autism; Bettelheim, Bruno; Infantile schizophrenia; Technique with children, psychoanalytic.

### Source Citation

Bettelheim, Bruno. (1967). *The empty fortress: Infantile autism and the birth of the self*. New York: Free Press.

### Bibliography

Bettelheim, Bruno. (1943). Individual and mass behavior in extreme situations. *Journal of Abnormal and Social Psychology*, 38, 417–452.

———. (1950). *Love is not enough*. New York: Free Press.

———. (1980). *Surviving and other essays*. New York: Vintage.

Lyons, Tom Wallace. (1979). *The pelican and after: A novel about emotional disturbance*. Richmond, VA: Prescott, Durrell and Co.

Mahler, Margaret S. (1952). On child psychosis and schizophrenia: Autistic and symbiotic infantile psychoses. In R. Eissler et al. (Eds.), *Psychoanalytic study of the child* (Vol. 7). New York: International Universities Press.

Winnicott, Donald W. (1989). *Psycho-analytic explorations*. Cambridge, MA: Harvard University Press.

## ENCOPRESIS

*Encopresis* is the name for problems with control of the anal sphincter after the age when such control is normally acquired (two or three years). The condition may be primary or secondary after a period of continence, and is characterized by bowel movements, usually during the daytime, under socially unacceptable conditions and excluding true incontinence, as produced by organic disorders of the sphincter or its related nerve structures. The term, used in clinical pediatric psychiatry, was introduced by Siegfried Weissenberg in 1926.

A clearer understanding of this symptom can be achieved by considering it in relation to the erotogenicity of the anal zone (Freud, 1905d), with its various components, including excitation of the mucous membranes and the pleasures derived from expulsion and muscular control. Michel Soulé views the erotization of retention as the central phenomenon. Non-renunciation of these instinctual satisfactions is rooted in the individual's conflictual relations with the people surrounding him during the period of toilet training—that is, the anal-sadistic stage, which is focused on issues of possession, on mastery of one's own body, and of others. The child's stools are cathected as a part of his or her own body and as representing internal objects; the subject refuses to give them up for exchange and instead saves them, often owing to a deficiency in symbolization that impedes the displacement of interest onto other objects. Anxiety plays a role, sometimes manifesting itself as a genuine defecation phobia with archaic contents, such as the destruction of internal objects, or the destruction of links, often in connection with the traumatic effects upon the child of intrusive parental fantasies or existential events involving loss.

Symptoms of encopresis can also arise from an inadequate cathexis of the body on the part of a child subject to some forms of deprivation. The secondary gains are proportionate to the involvement of the child's entourage: maintaining regressive ties to the mother; feelings of omnipotence; masochistic gratification. The failure of repression and the non-establishment of reaction-formations attest to the resistance of pregenital fixations to oedipal resolution—the definitive aim of toilet training, according to Anna Freud. Although encopresis can have a bearing on all types of psychopathology in the child, ranging from psychosis or perversion to quasi-normality, Bertrand Cramer has noted that the majority of cases involve neurosis.

GÉRARD SCHMIT

See also: Anality; Coprophilia; Eroticism, anal; Gift; Infantile neurosis; Libidinal stage; Mastery; Pregenital; Psychosexual development.

### Bibliography

Cramer, Bertrand, et al. (1983). Trente-six encoprétiques en thérapie. *Psychiatrie de l'enfant*, 26, 2, 309–410.

Freud, Anna. (1965). *Normality and pathology in childhood: assessments of development*. New York: International Universities Press.

Freud, Sigmund. (1905d). Three essays on the theory of sexuality. *SE*, 7: 130–243.

Soulé, Michel, et al. (1995). Les troubles de la defecation. In S. Lebovici, R. Diatkine, and M. Soulé (Eds.), *Nouveau traité de psychiatrie de l'enfant et de l'adolescent* (Vol. 4, pp. 2679–2700). Paris: Presses Universitaires de France.

Weissenberg, Siegfried. (1926). Über Enkopresis. *Zeitung der Kinderpsychiatrie*, 1, 69.

## ENCOUNTER

The word *encounter* designates the coming together of two elements, fortuitous or not, that are going to have an impact on each other. This notion is central to the theories of Piera Aulagnier, as it correlates to potentiality (psychotic potentiality). “To live is to experience in a continuous way what results from the situation of encounter,” she wrote in 1975 (p. 2).

The notion of encounter in the wider sense of the word for psychoanalysis concerns everything that has the character of an event, when it seems as if it is not predetermined. Nevertheless, Freud had demonstrated that an event has no sense and meaning, except as a part of a preexisting structure. Therefore the event never has a purely objective meaning, even if it results from an encounter that comes from the outside. Such an event has, in fact, already been shaped by the psyche according to mnemonic traces anterior to the encounter. Piera Aulagnier, however, accorded the notion of encounter a more fundamental meaning, that of a permanent rapport established between the body and the psyche, or between the subject's psyche and that of the mother. The relation between the psyche and the world is born at the time of the primordial event of the encounter.

Aulagnier opted to situate the inaugural encounter at the beginnings of the rapport between the mouth and the breast, a prototype of what she called the “complementary object-zone” (1975/2001, p. 19). “At the moment when the mouth meets the breast it meets and swallows a first mouthful of the world” (p. 15). The representation that the psyche has of itself will be a function of further encounters, either the encounter of the psyche with the body, on the one hand, or with the productions of the maternal psyche on the other.

Nevertheless, every encounter confronts psychic activity with an overload of information, up to the point where whatever was unrecognized returns to refute the representation (for example, the frustration of the real breast being missing, when a presence of the breast has been hallucinated).

This shows why the notion of encounter has been a useful one: It is opposed, in fact, to representations of the mother/infant relation in terms of fusion or dyad. Piera Aulagnier, on the contrary, affirmed that in the two psychic spaces, that of the mother and of the child, “the same object, the same experience of encounter will be inscribed by using two forms of writing and two *heterogeneous* relational schemata” (1975/2001, p. 15).

The notion of the “encounter” is also a necessary complement of “potentiality”, since it is precisely on the occasion of the encounter that potentiality can be actualized. In this context it is close to the notion of the event, when the latter is thought of as a triggering cause. However, in the context of psychosis, Aulagnier proposed a more specific definition of encounter: “The passage from a potential state of identificatory conflict to one that is manifest can result from an encounter that takes place long after childhood is past; an encounter between the subject and another, to whom is imputed the same power, which in childhood was exerted by actors in a reality scene of such a nature that it was not internalized at the time” (1984).

It is evident that the notion of encounter allows Aulagnier to avoid any overly strict determinism, one that would isolate a particular moment, in the subject or family environment, to account for its later psychic destiny.

In one of her last writings, dating from 1990, and so liable to serve as a conclusion, she remarked: “The essence of the relation of cause and effect in the psyche . . . is that it is the effect alone that can make a cause of the event. Now this effect is not fixed once and for all; it is itself the effect of an encounter, to be recalled, renegotiated, reinterpreted by future experiences. Only over the course of a long and arduous work of reinterpretation of lived experiences and past traces can a current experience reactivate things, or the I transform its past—to make of it the source and cause of its present” (1992 [1990]).

SOPHIE DE MIJOLLA-MELLOR

See also: Alienation; *L'Apprenti-historien et le Maître-sorcier. Du discours identifiant au discours délirant* [Apprentice historian and the master sorcerer, the]; Ideational representation; Pictogram; Primal, the; Psychotic potential.

### Bibliography

Aulagnier, Piera. (1984). *L'Apprenti-historien et le Maître-sorcier. Du discours identifiant au discours délirant*. Paris: Presses Universitaires de France.

———. (1992 [1990]). Voies d'entrée dans la psychose. *Topique*, 49, 7–29.

———. (2001). *Violence of Interpretation: From Pictogram to Statement*. (Alan Sheridan, Trans.). East Sussex Philadelphia: Brunner-Routledge. (Original work published 1975).

Mijolla-Mellor, Sophie de. (1998). *Penser la psychose. Une lecture de l'oeuvre de Piera Aulagnier*. Paris: Dunod.

## ENRIQUEZ-JOLY, MICHELINE (1931–1987)

Micheline Enriquez, a French psychoanalyst, was born on September 11, 1931, in Châlons-sur-Marne and died in an automobile accident on October 18, 1987, in Vaux-le-Pénil. She spent her childhood and adolescence in Sézanne, where she attended grammar school and high school. She passed her baccalaureate degree in modern literature. In 1949 Enriquez went to Paris to study at the Institut de psychologie (Institute of Psychology), where she obtained diplomas in applied psychology, psychopedagogy, and psychopathology, and at the Sorbonne, where she obtained a certificate in social psychology. She also studied Russian at the École des langues orientales (School of Oriental Languages) and took courses at the Institut d'études politiques de Paris (Paris Institute of Political Studies).

After working with Professor Jean Maisonneuve (social psychology) on the process of affinity and evaluating training activities, she was appointed a psychologist at the mental health clinic of Paris Medical School (under Professor Jean Delay of the Centre psychiatrique Sainte-Anne). She worked with Professors Pierre Pichot, Thérèse Lampérière, and J. Perse, with whom she wrote a study on hysteria. She also worked at the Versailles Hospital.

She underwent her training analysis with Serge Leclair of the Société française de psychanalyse (French Society for Psychoanalysis) before the 1964 split that led Jacques Lacan to found the École freudienne de Paris (Freudian School of Paris).

Her monitor was Piera Aulagnier. She joined the École freudienne at the time of its creation but, at the time of a second split, participated in the creation of the Quatrième groupe, Organisation psychanalytique de langue française (Fourth Group, Francophone Psychoanalytic Organization) in 1969. She served as secretary for analysis and secretary for research before becoming vice president in 1985 and president in 1986. She underwent a second analysis with Serge Videman. For several years she was responsible for teaching projective techniques at the Institut de Psychologie (Institute for Psychology) at the University of Paris.

Enriquez wrote a number of articles in the review *Topique* and in the *Nouvelle revue de psychanalyse*. She was awarded the Maurice Bouvet Prize in psychoanalysis in 1978 for three of her articles: “D'un corps à l'autre: réflexions sur le masochisme” (1971), “Fantasmes paranoïaques: différence des sexes, homosexualité, loi du père” (1974), “Analyse possible ou impossible” (1977a). She contributed an article to *Comment l'interprétation vient au psychanalyste* (1977b) and, in 1984, published *Aux carrefours de la haine*. Her last published work, “L'enveloppe de mémoire et ses trous” (1987), appeared shortly after her death. Two of her essays, “Le délire en héritage” and “Incidence du délire parental sur la mémoire des descendants,” a transcription completed the day before her death, were published in 1993.

As shown by the case studies she wrote, her work is based on her analytic practice and reflects on violence, lethal withdrawal of cathexis, the desire for historical and psychic reality, suffering, and the conditions for harmonious treatment, which, while not excluding the expression of negative affects, can mobilize life impulses and stimulate thought in analyst and analysand alike.

Enriquez provided new insights into paranoia, masochism, and what she referred to, after the Marquis de Sade, as apathy. She showed that paranoiacs and masochists eroticize suffering and hatred, and she found in paranoia and masochism the mechanisms of their object choices. Those who are apathetic reject affect and hatred to distance themselves from others in order to survive. She insisted on the need for the child, when confronted by delusional speech from one of its parents, to negotiate the violence imposed to avoid repeating it. She stressed the importance of a common memory between analyst and analysand, a condition

for remembering to be fruitful and for access to history. For Enriquez, everything that fell within the sphere of love and reciprocity was capable of struggling against the spread of evil that resulted in anger against the self or others.

Enriquez has been referred to as one of the most highly esteemed psychoanalysts in France, where her clinical work and theoretical contributions were highly regarded, independently of her institutional associations. She was a member, since its foundation, of the Association internationale d'histoire de la psychanalyse (International Association of the History of Psychoanalysis). Issue no. 42 of *Topique*, "Mémoire et réalité" (1988), was dedicated to her memory. Her work has been translated into English, Spanish (she is well known in Argentina), Italian, and Greek. Her influence in Brazil continues to remain strong.

EUGÈNE ENRIQUEZ

*See also:* Intergenerational; Pain; Psychic envelopes; Quatrième groupe (O.P.L.F.), Fourth group; Secret.

### **Bibliography**

- Enriquez, Micheline. (1971). D'un corps à l'autre: Réflexions sur le masochisme. *Topique*, 7–8, 85–118.
- . (1974). Fantômes paranoïaques: Différence des sexes, homosexualité, loi du père. *Topique*, 13, 23–58.
- . (1977a). Analyse possible ou impossible. *Topique*, 18, 49–62.
- . (1977b). Libres pensées. In Robert Barande (Ed.), *Comment l'interprétation vient au psychanalyste* (pp. 95–104). Paris: Aubier Montaigne.
- . (1980). Du corps de souffrance au corps en souffrance. *Topique*, 26, 5–27.
- . (1984). *Aux carrefours de la haine: Paranoïa, masochisme, apathie*. Paris: Éditions de l'Épi.
- . (1987). L'enveloppe de mémoire et ses trous. In Didier Anzieu et al. (Eds.), *Les enveloppes psychiques*. Paris: Dunod.
- . (1993a). Le délire en héritage. In René Kaës et al. (Eds.), *Transmission de la vie psychique entre générations*. Paris: Dunod.
- . (1993b). Incidence du délire parental sur la mémoire des descendants. In René Kaës et al. (Eds.), *Transmission de la vie psychique entre générations*. Paris: Dunod.

## **ENURESIS**

*Enuresis* is incomplete, or total lack of, bladder control in children past the age of four to five years, when bladder control is normally achieved. It is considered primary when a child has never been consistently dry. In secondary nocturnal enuresis, bedwetting begins after a period of adequate bladder control and suggests regression due to such traumatic factors as separation, loss, or illness. Enuresis is distinguished from genuine organic urinary incontinence. Enuretic urination, as a rule, is nocturnal and involuntary. It may be also associated with daytime events.

As a disorder that attracts the interest of a number of medical specialists, enuresis has spawned a variety of hypotheses concerning its etiology. The deep sleep of the enuretic child has been implicated, though without evidence of any unusual sleeping habits, save increased resistance to specific waking stimuli. The bladder capacity of the enuretic child is usually normal, although in some cases an immature bladder has been demonstrated, and this can cause a nocturnal surge in bladder pressure. In a few cases, disorders (or delayed maturation) of circadian rhythms due to secretion of antidiuretic hormones may disrupt, or delay the development of, the normal relationship between diurnal and nocturnal production of urine, and this can produce functional nocturnal polyuria. Finally, studies of families and twins have established a genetic component.

Although psychological and environmental factors have often been investigated, a specific psychological profile for enuresis has not yet emerged. Complicating matters is that relevant factors differ according to whether the symptom is an isolated one or forms part of a more complex clinical picture and a definite psychopathology.

Freud emphasized the libidinal dimension of primary enuresis. Beginning with the case of Dora (1905e [1901]), he interpreted enuresis as a substitute for genital gratification, noting consistent links between enuresis and fire, a theme that he discovered in dreams as representative of frightening, aggressive, or erotic drives. As the gratification of an organic need, Freud suggested, urination counts as one of the autoerotic and infantile pleasures; the infant renounces it only with reluctance under the pressure of toilet training (1916–1917a [1915–1917]).

Even if this classical conception must be viewed today in connection with other considerations, psychotherapy of enuretic children often demonstrates the

relevance of Freudian intuition. Gérard Schmidt and Michel Soulé (1985) stress the significance of primary enuresis in the libidinal economy of the enuretic child, together with various direct instinctual gratifications that indicate continued and persistent eroticization of urination. Gains in controlling secondary enuresis are correlated with reactions of the child's caregivers and the availability of other means of gratification.

The study of the psychological factors involved in enuresis must take into account several factors implicated in successful toilet training: (1) the gradual maturation of control over the somatic functions, with individual inborn variations; (2) the affective investment in excretory functions in different stages of libidinal development; and (3) interactions with the environment, ranging from the child's privileged relationship with its mother to familial and social customs concerning the child's acquisition of sphincter control.

GERARD SCHMIDT

*See also:* Eroticism, urethral; Institut Max-Kassowitz.

### **Bibliography**

- Freud, Sigmund. (1905e [1901]). Fragment of an analysis of a case of hysteria. *SE*, 7: 1–122.
- . (1916–1917a [1915–1917]). Introductory lectures on psycho-analysis. *SE*, 15–16.
- Kreisler, Léon. (1977). Enurésie. In *Encyclopédie médico-chirurgicale* (Vol. *Pédiatrie*, fasc. 4101-G-95). Paris: Encyclopédie médico-chirurgicale.
- Schmit, Gérard, and Soulé, Michel. (1985). L'énurésie infantile. In Serge Lebovici, René Diatkine, and Michel Soulé (Eds.), *Nouveau traité de psychiatrie de l'enfant et l'adolescent* (pp. 1751–1770). Paris: Presses Universitaires de France.

### **Further Reading**

- Blum, Harold P. (1970). Maternal psychopathology and nocturnal enuresis. *Psychoanalytic Quarterly*, 39, 609–619.
- Calef, Victor, Weinshel, Ed, et al. (1980). Enuresis: A functional equivalent of a fetish. *International Journal of Psychoanalysis*, 61, 295–306.

---

## **ENVY**

Envy is a primitive force in the personality that is opposed to, and therefore mounts destructive attacks

upon, parts of the object felt to be good. It attacks aspects of the libido—love, constructiveness, integration—simply because of their life-giving characteristics. This notion first appears in *Envy and Gratitude* (Klein, 1957).

Freud was uncertain about the clinical usefulness of the concept of the death instinct. Klein found ways of showing its clinical relevance, especially in her work with children. The primary destructive force, the death instinct, aims at destroying the ego. Freud (1926) recognized that the ego needs to escape this very early experience of threat, and that it can do so by projecting the death instinct outwards. Thus the ego contrives to see the danger to itself as coming from external objects. This danger may then coincide, he thought, with some real external threat. As Klein (1932) added, the external object may be a harsh critical parent (then internalized as a persecuting superego). Then the external enemy can be attacked, as can other aspects of the death instinct turned against an external object. In both these processes of establishing outwardly directed impulses, the libido may fuse to some degree with the death instinct.

Later and in contrast with the above, Klein described a very different manifestation of death instinct: primary envy. In this instance the destructive force is directed against an external object that is not a threat but a good object, typically the mother's breast, which feeds and comforts. To the external good object is attributed a wish for life and a wish to preserve life in the ego. In this case, the good object represents a part of the libido projected into an external object. And it is attacked there by impulses derived from the death instinct now turned away from the ego itself. The death instinct, directed against those (libidinal) parts of the ego concerned with the wish to live, remains a destructive force against them when they are projected. Klein's view is a generalization and extension of Freud's notion of penis envy.

Klein developed the idea of the death instinct in terms of relations to the object and to the self. Rosenfeld (1971) described states in which the ego is dominated by aspects of the death instinct. Since Freud's theory of the death instinct was never fully accepted, Klein's idea of envy was also contentious (Joffe, 1969). Envy represents a primary kind of evil, and it is difficult often to accept such a state in an innocent infant.

Others have attributed aggression in infancy and childhood to frustration of libidinal impulses. Wilfred

Bion described paroxysms of aggression arising in infants when an infant's insistent projection meets an uncontainable mother frightened by the infant's fear of death. Here the anger of frustration can appear much like envy.

ROBERT D. HINSHELWOOD

See also: *Envy and Gratitude*; Links, attacks on; Logic(s); Narcissistic neurosis; Oral-sadistic stage; Primary object.

### **Bibliography**

- Freud, Sigmund. (1926). Inhibitions, symptoms and anxiety. *SE*, 20: 75–172.
- Joffe, Walter. (1969). A critical review of the envy concept. *International Journal of Psycho-Analysis*, 50, 533–545.
- Klein, Melanie. (1932). *The psycho-analysis of children*. London: Hogarth.
- . (1957). *Envy and gratitude: A study of unconscious forces*. London: Hogarth Press.
- Rosenfeld, Herbert. (1971). A clinical approach to the psycho-analytic theory of the life and death instincts: An investigation into the aggressive aspects of narcissism. *International Journal of Psycho-Analysis*, 52, 169–178.
- Segal, Hanna. (1993). Review of *A dictionary of Kleinian thought*. *International Journal of Psycho-Analysis*, 74, 417–419.

---

## **ENVY AND GRATITUDE**

*Envy and gratitude* is the last of Melanie Klein's major contributions to psychoanalytic theory. She presented a paper, "A study of envy and gratitude," at the Geneva International Congress of Psycho-Analysis in 1955. This was later expanded into a short book for publication in 1957.

From her first publications Melanie Klein reported that a major source of anxiety from the beginning of life is destructiveness. At first she was interested in aggression and the paranoid cycles of fear and violence as the origins of anxiety (Klein, 1929a). Later she understood anxiety in terms of damage to internal objects (the depressive state), which then gave rise to guilt (Klein, 1935). Still later she understood self-directed aggression, in the form of splitting and fragmentation of the ego itself, to arise from the death instinct (Klein, 1946). The ego, as it begins to develop, protects itself from its inherent self-destruction by an

immediate projection onto an external object of that destructiveness toward the life-affirming side of the ego (Klein, 1932).

Finally, in 1957 she developed a new understanding. Envy projects onto an external object the affirmation of life and attacks it there. Envy, which Klein referred to as "primary envy," is an attack on life itself in the form of an external object that represents the wish to keep the ego alive and hence on which the ego is utterly dependent. Those attacks are achieved, in fantasy, by the very earliest methods available to the infant: orally scooping out the good object, the mother's breast. She believed that primary envy is the process underlying other forms of envy, including penis envy.

The consequence for the infant is that it has difficulty in finding a good object in the external world that, when introjected, can be definitely and stably good to the ego. However, there is also the libido, and in its earliest form, it too relates to the external source of life in a powerful surge of feeling that Klein later called "gratitude."

Envy, however, causes trouble and leaves potentially disturbing traces in the later personality. For this reason, Klein and her colleagues subsequently concentrated on envy. Klein regarded envy as such an early and primary mode of defense against the self-destruction of the death instinct as to be a constitutional, or innate, reaction.

With this stand she called down great criticism on herself. The death instinct was always contentious; Freud regarded it as silent. A primary source of aggression against objects was held by many to be unnecessary, as frustration of libido was a sufficient source and explanation. And many, perhaps most, analysts found it impossible to conceive of a bounded ego operating in relation to a clearly defined external object. Throughout her career Klein had had to confront disbelief of her observations on violence and aggression in children. To postulate innate violence as the first force preoccupying the infant redoubled that disbelief.

The publication of these contentious ideas came, ironically, at a time when Klein might have felt satisfied that her psychoanalytic work was becoming appreciated. After the controversial discussions with Anna Freud in the early 1940s, the group of her close associates and colleagues had been reduced to a handful, with a number of students. By 1952 her views had



survived, and her papers from the controversial discussions were published in book form. Her ideas had also developed enormously with experimental work on the psychoanalysis of schizophrenia.

Colleagues marked her seventieth birthday with a festschrift containing the papers of fifteen contributors apart from herself (Klein et al., 1955). At this moment of success her new book on envy (1957) brought more setbacks. The pace of her ideas had gone so fast that many followers became increasingly reserved about their support. Paula Heimann (1962) and Donald Winnicott (1965) made a distinct break from Klein at this time. In contrast, those who remained loyal to Klein fervently embraced the idea of envy.

From then to the present (2004), allegiance to the concept of envy has been a kind of badge of membership in the Klein group within the British Psycho-Analytical Society. Because of these group allegiances, the concept has been seriously studied only by Klein's followers.

ROBERT D. HINSHELWOOD

*See also:* Envy; Klein-Reizes, Melanie.

### Source Citation

Melanie Klein. (1957). *Envy and gratitude: A study of unconscious forces*. London: Hogarth Press. Reprint: (1975). *The writings of Melanie Klein*, Vol. 3: *Envy and gratitude and other works, 1946–1963* (pp. 176–235). London: Hogarth Press and the Institute of Psycho-Analysis.

### Bibliography

- Heimann, Paula. (1962). Contribution to the discussion of "The curative factors in psycho-analysis." *International Journal of Psycho-Analysis*, 43, 228–231.
- Klein, Melanie. (1929a). Infantile anxiety situations reflected in a work of art and in the creative impulse. *International Journal of Psycho-Analysis*, 10, 436–443.
- . (1929b). Personification in the play of children. *International Journal of Psycho-Analysis*, 10, 171–182.
- . (1932). The psycho-analysis of children. London: Hogarth.
- . (1935). A contribution to the psychogenesis of manic-depressive states. *International Journal of Psycho-Analysis*, 16, 145–174.
- . (1946). Notes on some schizoid mechanisms. *International Journal of Psycho-Analysis*, 27, 99–110.

———. (1957). *Envy and gratitude: A study of unconscious forces*. London: Hogarth Press.

———. (1975). *The Writings of Melanie Klein*. London: Hogarth.

Klein, Melanie, Heimann, Paula, and Money-Kyrle, Roger. (1955). *New directions in psycho-analysis*. London: Tavistock Publications.

Winnicott, Donald W. (1965). *The maturational processes and the facilitating environment: studies in the theory of emotional development*. London: Hogarth and the Institute of Psycho-Analysis.

---

## EPISTEMOLOGY. *See Psychoanalytic epistemology*

---

## ERIKSON, ERIK HOMBURGER (1902–1994)

Erik Homburger Erikson, American psychoanalyst, was born on June 15, 1902 in Frankfurt-am-Main, and died on May 12, 1994, on Cape Cod, Massachusetts.

Erikson was the son of a Danish mother and unknown father. His step-father was a German pediatrician in Karlsruhe, and after Erikson left home his mother and step-father, both Jewish, moved to Palestine. In Vienna, Anna Freud became Erikson's analyst in 1927, and he graduated as a child analyst from the Vienna Psychoanalytic Institute in 1933. Artistically inclined, Erikson said that he was first attracted to Freud's ideas by the magnificence of his German prose.

He entered Freud's circle in the summer of 1927, when he was working as a painter of children's portraits without any firm professional goals. An old school friend was at that time the director of a small progressive school in Vienna run by Dorothy Burlingham and Eva Rosenfeld, both close friends of Anna Freud.

Most of the children at the school were in psychoanalytic treatment, and a number of the parents were undergoing analysis. Erikson was hired to paint the portraits of the four Burlingham children. After a brief period as a tutor, Erikson was asked whether he would consider becoming a child analyst—a profession he had not heard of before.

By the end of 1933 Erikson had settled in Boston, Massachusetts. He worked in private practice as a

child analyst, the first male in that field. He also was associated with the Harvard Psychological Clinic under Henry A. Murray, and did research at Yale. In 1939 Erikson became an American citizen, changing his name from his step-father's Homburger to the self-created Erikson. Later he moved to Berkeley, California where he became one of the founders of the San Francisco Psychoanalytic Society. After a 1951 loyalty oath controversy at the height of the McCarthy period, Erikson resigned from the University of California and moved to the Austin Riggs Center in western Massachusetts. In 1960 he accepted a prestigious university professorship at Harvard College.

Always uncomfortable in academic life, since he himself was without any formal training aside from being an analyst, Erikson retired from Harvard in the early 1970s to return to California where he worked at the Mt. Zion Department of Psychiatry in San Francisco. In 1987 he returned to Cambridge, Massachusetts where an Erikson Center was established under Harvard's auspices. Erikson's final days were spent at a nursing home at Harwich on Cape Cod, near Cotuit where he and his wife Joan had long had a summer home.

Erikson's *Childhood and Society* first came out in 1950, and was reprinted more than any of his other books. *Young Man Luther* (1958) was a study in psychoanalysis and history, as Erikson treated Luther as an innovative psychologist whose Christian teachings complemented those of classical analysis. While *Identity and the Life Cycle* (1959) was a collection of his papers on ego psychology. *Insight and Responsibility* (1964) was a set of papers on the ethical implications of psychoanalytic insight. *Gandhi's Truth* (1969), a prize-winning book, sought the origins of militant non-violence in Gandhi's life. Erikson also gave the 1973 Jefferson Lectures in the Humanities, which appeared as *Dimensions of a New Identity* (1974). *Life History and the Historical Moment* (1975) was another collection of essays, and so was *A Way of Looking at Things* (1987).

Erikson used his concept of ego identity in order to move psychoanalytic theory away from Freud's libido approach; Erickson saw society as a constructive source of ego strength. Erikson also developed the notion of psychohistory as part of his effort to bring psychoanalysis into the modern social sciences.

PAUL ROAZEN

*Work discussed: Childhood and Society.*

*Notion developed: Ego identity.*

*See also: Burlingham-Rosenfeld/Hietzing Schule; Ego (ego psychology); Identity; Principle of identity preservation; Psychobiography; Psychohistory; United States.*

### **Bibliography**

Erikson, Erik H. (1950). *Childhood and Society*. New York: W. W. Norton.

———. (1958). *Young Man Luther*. New York: W. W. Norton.

———. (1959). *Identity and the Life Cycle*. New York: International Universities Press.

———. (1964). *Insight and Responsibility*. New York: W. W. Norton, 256 p.

———. (1969). *Gandhi's Truth*. New York: W. W. Norton.

---

## **EROS**

In ancient Greece the word *Eros* referred to love and the god of love. In his final theory of the drives, Sigmund Freud made Eros a fundamental concept referring to the life instincts (narcissism and object libido), whose goals were the preservation, binding, and union of the organism into increasingly larger units.

Eros the unifier is opposed to, and yet was blended into, the death instinct, an antagonistic force leading to the destruction, disintegration, and dissolution of everything that exists. "In this way the libido of our sexual instincts would coincide with the Eros of the poets and philosophers which holds all living things together" (Freud, 1920g, p. 50).

The term *Eros*, understood as a life instinct antagonistic to the death instinct, appeared for the first time in *Beyond the Pleasure Principle* (1920g), where Freud used it to establish a dynamic polarity that would define a new instinctual dualism. Freud wrote, "Our speculations have suggested that Eros operates from the beginning of life and appears as a 'life instinct' in opposition to the 'death instinct' which was brought into being by the coming to life of inorganic substance. These speculations seek to solve the riddle of life by supposing that these two instincts were struggling with each other from the very first" (p. 61). In this essay Freud refers to the doctrine of the Greek physician and philosopher Empedocles of Agrigento

(c. 490–430 B.C.E.), for whom the production of all things results from the interplay of two forces, Love and Discord, conceived of as the impersonal forces of attraction and repulsion.

Yet Freud's theoretical innovation is more than the pure speculations of philosophy, biology, or physics. Revision of his concepts was called for by his experience in psychoanalytic practice. He posited within the organism a primal masochism derived from the action of the death instinct to account for certain clinical problems: ambivalence in affective life, nightmares associated with traumatic neurosis, masochism, and negative therapeutic reactions.

Freud's uses of the term *Eros* (86 of 88 occurrences, according to Guttman's *Concordance*) is contemporary with his final theory of the instincts developed after 1920. The word itself, with its multiple meanings, enabled Freud to combine many things that he had previously separated and contrasted: love between the sexes, self-love, love for one's parents or children, "friendship and love among mankind in general," "devotion to concrete objects and abstract ideas," and partial sexual drives (component instincts). This expanded concept of love led Freud to evoke, on several occasions (1920g, 1921c, 1924c, 1925e [1924]), "the all-inclusive and all-preserving Eros of Plato's *Symposium*" (1925e, p. 218).

Although the concept of Eros, properly speaking, emerged late in Freud's work, this did not prevent him from claiming that all his earlier discoveries about sexuality can be seen in terms of Eros. Psychoanalysis showed that sexuality did not conceal "impulsion towards a union of the two sexes or towards producing a pleasurable sensation in the genitals" (1925e, p. 218), and that sexuality was thus different from genitality.

Though the term *Eros* does not appear in the original texts, two notes, one from 1925 in *The Interpretation of Dreams* (1900a) and the other from 1920 in *Three Essays on the Theory of Sexuality* (1905d), reinforce the use of "Eros" as a synonym for "sexual" in the discovery of psychoanalysis: "The situation would be different if 'sexual' was being used by my critics in the sense in which it is now commonly employed in psychoanalysts—in the sense of 'Eros'" (1900a, note 1925, p. 161). Freud even justified his failure to use the word earlier: "Anyone who considers sex as something mortifying and humiliating to human nature is at liberty to make use of the more genteel expressions 'Eros'

and 'erotic.' I might have done so myself from the first and thus spared myself much opposition. But I did not want to, for I like to avoid concessions to faintheartedness. One can never tell where that road may lead one; one gives way first in words, then little by little in substance too" (1921c, p. 91). Occurrences of the terms "Eros" (after 1920) and "eroticism" (after 1894) overlap in Freud's writings without ever leaving the field of sexuality.

Freud early on recognized the erotic character of repressed representations that lie at the heart of neurotic symptoms. He cites "the case of a girl, who blamed herself because, while she was nursing her sick father, she had thought about a young man who made a slight erotic impression on her" (1894a, p. 48), and who is then constrained to treat this unwanted representation of a sexual nature as if it had "never occurred." Freud conceived mental conflict as a moral conflict in which the troublemaker Eros stirs up trouble in the form of a symptom. He saw sexuality as a trauma that goes far beyond the well-known scenes of sexual seduction. Eros forces the ego to defend itself and thus participates in the division and fragmentation of the psyche. Repressed erotic representations later return in the form of symptoms or compromise formations that substitute for sexual activity or "precipitates of earlier experiences in the sphere of love" (1910a, p. 51). Such instances of deferred or aborted love are remote from sexual attraction and genital activity. Sexuality exists from infancy, is fundamentally perverse and polymorphous, and consists of a bundle of partial sexual drives that seek satisfaction independently of one another, in autoerotic fashion. The oral drive, for example, is seen as a mouth that kisses itself.

The 1920 footnote in *Three Essays on the Theory of Sexuality* retroactively referring to Eros (1905d, p. 266n) serves Freud's theoretical interests: to recognize infantile sexuality as something distinct from genitality, to emphasize the diphasic nature of sexual life, and to provide the concept of the drives with a mythical status, infantile in appearance and dominated by an ongoing and insatiable quest. Here Eros appears to conflict with the ego's instinct for self-preservation. The Oedipus complex determines the outcome of this conflict through the possibilities it offers for orienting the libido toward a sexual object (one that is no longer only sexual) by means of the phallus. The Oedipus complex is responsible for ensuring that the subject becomes satisfied in love after the reorganization at puberty, when the partial

drives (component instincts) are enlisted in the service of an organized genital apparatus. Failing this, the subject will fall ill unless an alternative object is found through sublimation.

Eros is not only a cause of symptoms but can also become the means for their relief. The theoretical model of Eros as healer is beautifully illustrated in *Delusions and Dreams in Jensen's "Gradiva"* (1907a [1906]).

Love was also at the center of the psychoanalytic experiment from the time of its initial discovery via transference. In the middle period of the development of psychoanalysis (1912–1915), the homage to love in *Delusions and Dreams* would butt up against its limitations in a theory of transference, which shows love to support resistance to remembering, and hence to analysis. Moreover, Freud discovered in cases of sexual impotence of psychological origin that a conflict exists between the “affectionate current” and the “sexual current”: “Where they love they do not desire, and where they desire they cannot love” (1912d, p. 183). This text anticipates Freud’s comments in “On Narcissism: An Introduction” (1914c). In this text, Freud saw the narcissistic libido as conflicting with erotic love of the object: Narcissus versus Eros. The ego claims a place among the sexual objects, and the self-preservation instincts have a libidinal nature. What distinguishes Eros is its link with objects: “A strong egoism is a protection against falling ill, but in the last resort we must begin to love in order not to fall ill, and we are bound to fall ill, if, in consequence of frustration, we are unable to love” (1914c, p. 85).

*Beyond the Pleasure Principle* (Freud, 1920g) overturned these earlier constructions. The theory of a death instinct, which worked in silence, forced Freud to combine the ego instincts and sexual instincts directed at objects, grouping them under the umbrella of a single force whose goal was union: Eros. Such an Eros is no longer a troublemaker, a divisive agent that disturbs the mental apparatus. It is the power of creation, of reproduction; it makes existence possible and postpones the return to an inorganic state. When discussing the life-preserving sexual instincts (object libido and ego), Freud explicitly refers to the myth of Eros recounted by Aristophanes in Plato’s *Symposium*. But the life and death instincts rarely come into play in isolation: They form various amalgams in which each attempts to make use of the other’s strength to its own advantage. Freud shows that moral masochism, for example, “becomes a

classical piece of evidence for the existence of fusion of instinct. Its danger lies in the fact that it originates from the death instinct and corresponds to the part of that instinct which has escaped being turned outwards as an instinct of destruction. But since, on the other hand, it has the significance of an erotic component, even the subject’s destruction of himself cannot take place without libidinal satisfaction” (1924a).

In Freud’s last work, it is as if the scandal of the discovery of sexuality was displaced in favor of the theoretical innovation of the death instinct. Eros as the embodiment of Aristophanes’ myth or Empedocles’ theories appears to get the better of Eros as the embodiment of desire, an Eros whose birth is given in the myth recounted by Diotima in *The Symposium*.

Jacques Lacan distances, without completely separating, love and desire (Eros). Love is the mirage in which desire is caught. The phallus is the fulcrum between the object that gives rise to desire and the part of the subject, minus language, that is forever lost. “Therefore, to love is to give what one does not have, and we can only love by acting as if we don’t have, even if we do” (Lacan, 1991).

ROLAND GORI

*See also:* Animus-Anima (analytical psychology); *Beyond the Pleasure Principle*; Binding/unbinding of the instincts; *Civilization and Its Discontents*; Drive/instinct; Genital love; German romanticism and psychoanalysis; Libido; Life instinct (Eros); Marcuse, Herbert; Myth; Sexuality.

### **Bibliography**

- Freud, Sigmund. (1894a). The neuro-psychoses of defence. *SE*, 3: 41–61.
- . (1900a). The interpretation of dreams. *SE*, 4: 1–338; 5: 339–625.
- . (1905d). Three essays on the theory of sexuality. *SE*, 7: 123–243.
- . (1907a [1906]). Delusions and dreams in Jensen’s “Gradiva.” *SE*, 9: 1–95.
- . (1914c). On narcissism: An introduction. *SE*, 14: 67–102.
- . (1920g). Beyond the pleasure principle. *SE*, 18: 1–64.
- . (1921c). Group psychology and the analysis of the ego. *SE*, 18: 65–143.

- . (1924a). Letter to Le Disque Vert. *SE*, 19: 290–290.
- . (1924b [1923]). Neurosis and psychosis. *SE*, 19: 147–153.
- . (1924c). The economic problem of masochism. *SE*, 19: 155–170.
- . (1925e [1924]). The resistances to psycho-analysis. *SE*, 19: 211–222.
- Guttman, Samuel A. (1984). *The concordance to "The standard edition of the complete psychological works of Sigmund Freud"* (2nd ed.). New York: International Universities Press.
- Lacan, Jacques. (1991). *Le séminaire. Book 8: Le transfert*. Paris: Seuil.

## EROTICISM, ANAL

The term *anal eroticism* is defined as sexual pleasure predominantly linked to the excitation of the anal sphincter and the functions of excretion in infancy.

In his correspondence with Wilhelm Fliess, Freud observed that sexually-based emotional discharges originating in the anal region, like those in the mouth and throat, had ceased by the time the normal person reached adulthood (letter of November 14, 1897, 1950a). He continued, “the memory of [stimulation] will produce by deferred action ... not a release of libido but of an unpleasure” (p. 269). In January of 1898, he sent his friend a summary of his “*Drekkologie*” (1985c [1887–1904], p. 291), a neologism that he coined during his self-analysis to designate the science of filth.

In his *Three Essays on the Theory of Sexuality* (1905d), Freud described how the child’s sexual activity could be anaclitically supported by the anal zone: sexual activity in the infant is propped up by another physiological function, namely defecation; this occurred in accordance with Freud’s general conception of anaclitic erogenous zones. There were, in his view, three erogenous zones that could thus prop up physiological functions: oral, anal, and genital. Freud noted that to a certain degree the excitability linked to these zones could remain connected to genitality throughout life. The human sexual drive was thus a highly complex mechanism, produced by the contributions of numerous components, of partial drives. One of those components was anal eroticism, which defines one of the pregenital organizations of the libido. Freud wrote that “The playing of a sexual part

by the mucous membrane of the anus is by no means limited to intercourse between men: preference for it is in no way characteristic of inverted feeling” (1905d, p. 152). He thus initiated all the psychoanalytic research that would later define the role of anal masturbation in relation to the constitution of the ego in both men and women.

In “Character and Anal Erotism” (1908b), Freud described a specifically anal character. As with all other elements of eroticism, a part of the excitation contributes to sexuality while another part was diverted from sexual aims and directed towards other ends by the process of sublimation. He recognized the traits of the anal character (orderliness, parsimony, and obstinacy) as the results of the sublimation of anal eroticism. In particular, the way of handling money merges with psychic interest in excrement, the product of the anal zone.

Freud suggested in a letter to Sándor Ferenczi that anal eroticism might have the same relation to hypochondria as sadism did to obsessional neurosis. In “The Disposition to Obsessional Neurosis” (1913i), he suggested that the passive current of sexuality was fed by anal eroticism, while activity coincided with sadism. The accentuation of anal eroticism during the pregenital stage of organization could predispose a man, in the genital stage, to homosexuality.

Within the framework of a discussion of stages of the libido, anal eroticism was at the center of the dialogue between Freud and Karl Abraham. Their common research led to Freud to write, among other essays, “Mourning and Melancholia” (1916–1917g [1915]). One of melancholia’s striking characteristics derives from an anal eroticism which is torn from its connections and regressively transformed. For Freud, the regression connected with this illness allowed him to discover the importance of anal eroticism and its involvement with relationship to the object, whether this was expressed in terms of retention or expulsion.

Freud’s writings on narcissism and object relations were clarified by this insight. In his article “On Transformations of Instinct as Exemplified in Anal Erotism” (1917c), he hypothesized that defecation provided the infant with its first opportunity to choose between a narcissistic attitude and one of object-love. Stubbornness and obstinacy came from the narcissistic persistence of anal eroticism. The stool was the object of a loss that gave rise to feelings of ambivalence. Toilet

training supplied a model for object relations, for the ego latched on to this experience, which would color its future relationships. Later Freud theorized, in *Civilization and Its Discontents* (1930a), that “Anal erotism . . . succumbs in the first instance to the ‘organic repression’ which paved the way to civilization” (p. 100n).

Anal eroticism and its links with introjection and projection were studied clinically by Karl Abraham. According to him, each of the two early stages of psychosexual development, the oral and the anal, included a substage. The ambivalence arising during the second, oral-sadistic substage of the oral stage was reinforced during the immediately following anal-sadistic substage (Abraham, 1924/1949). Freud later (1933a [1932]) adopted Abraham’s substages, characterizing the first as destructive and the second as possessive and conservative with respect to the object.

The work of Abraham and Freud made it possible to understand how “the fear of becoming poor . . . is derived from anal erotism” (1917e, p. 252). This idea inspired Melanie Klein (1935) when she conceptualized the tendencies to idealize and denigrate of the object, and also the manic defenses related to such regressive states that would eventually define her notion of a paranoid-schizoid position.

Ernest Jones (1918), for his part, took up the connections between anal erotism and the capacity for concentration as the origin of thought. Leonard Shengold (1985) asserted that an excess of control prevented anal erotism from being manifested. This excess was dehumanizing because of links that forced narcissism and anal erotism into a deobjectalizing regression.

Note that anal eroticism should be seen in relationship with the mastery of the ego functions and with the mastery wielded over the object as separate from the subject. André Green (1993/1999) has considered the importance of primary anality for subjectivation and its influence on the object relation.

DOMINIQUE J. ARNOUX

*See also:* Anality; Castration complex; Character formation; Coprophilia; Erotogenicity; Feces; Gift; Libidinal stage; Mastery; Money in the psychoanalytic treatment; “Notes upon a Case of Obsessional Neurosis” (Rat Man); Preenital; Psychosexual development; Stage (or phase); Symbolization, process of.

## Bibliography

- Abraham, Karl. (1949). A short study of the development of the libido, viewed in the light of mental disorders. In *Selected papers of Karl Abraham* (pp. 418–501). London: Hogarth Press. (Original work published 1924)
- Freud, Sigmund. (1905d). Three essays on the theory of sexuality. *SE*, 7: 123–243.
- . (1913i). The disposition to obsessional neurosis: A contribution to the problem of choice of neurosis. *SE*, 12: 311–326.
- . (1916–1917g [1915]). Mourning and melancholia. *SE*, 14: 237–258.
- . (1930a [1929]). Civilization and its discontents. *SE*, 21: 57–145.
- . (1933a [1932]). New introductory lectures on psycho-analysis. *SE*, 22: 1–182.
- . (1985c [1887–1904]). *The complete letters of Sigmund Freud to Wilhelm Fliess, 1887–1904* (Jeffery M. Masson, Ed. and Trans.). Cambridge, MA: Belknap/Harvard University Press.
- Green, André. (1999). *The work of the negative* (Andrew Weller, Trans.). London: Free Association. (Original work published 1993)
- Jones, Ernest. (1948). Anal-erotic character traits. In *Papers on psycho-analysis* (5th ed.). Boston: Beacon Press. (Original work published 1918)
- Klein, Melanie. (1935). A contribution to the psychogenesis of manic-depressive states. In *The writings of Melanie Klein* (Vol. 1, pp. 262–289). (Reprinted from *International Journal of Psycho-Analysis*, 16, (1935) 145–174.)
- Shengold, Leonard. (1985). Defensive anality and anal narcissism. *International Journal of Psycho-Analysis*, 66, 47–74.

---

## EROTICISM, ORAL

Sexual pleasure that is linked predominantly to the excitation of the oral cavity and the lips, first experienced through an infant’s feeding, is defined as oral eroticism.

Freud spoke of the “oral sexual system” as early as his letters to Wilhelm Fliess (letter of January 3, 1897, in 1950a, p. 222). Sucking was from then on considered as a sexual activity, and the lips, together with the surrounding area, as the oral erogenous zone. The sexual drive acquires an autonomy vis à vis the vital functions (nutrition) which support it, and satisfies itself in autoerotic fashion. Freud remarked that this

excitability may remain, to a certain degree, linked to genitality. The human sexual drive can appear therefore as a highly complex montage, born of the confluence of numerous factors, some of which are drives known as “partial,” which at the beginning were independent.

One of the components of the pregenital organization of the libido, consequently, issued directly from oral eroticism. In *Three Essays on the Theory of Sexuality* (1905d), Freud distinguished between two pregenital phases: the oral or cannibal phase and the anal-sadistic phase. He added: “[During the oral phase] the sexual aim consists in the incorporation of the object—the prototype of a process which, in the form of identification, is later to play such an important psychological part” (p. 198). This constituted, therefore, a way of relating to the object (note of 1915).

In his article, “Mourning and Melancholia,” (1916–1917g) Freud described identification as a “preliminary stage of object-choice, that it is the first way—and one that is expressed in an ambivalent fashion—in which the ego picks out an object” (p. 249). It would like to incorporate the object, and that by way of devouring it. Therefore in the phase of the oral organization of the libido, the loving attachment to the object still coincides with the annihilation of the latter, as Freud affirmed in *Beyond the Pleasure Principle* (1920g).

In “The Economic Problem of Masochism,” (1924c) he emphasized that the existence of masochism is expressed erogenously, in all phases of libido development; erogenous masochism often changes its psychic dress. So, “The fear of being eaten up by the totem animal (the father) originates from the primitive oral organization” (p. 165).

Karl Abraham, in “A Short Study of the Development of the Ego, Based on an Analysis of Mental Problems” (1924), said that sadistic drives always have a special affinity with anal eroticism, rather than oral eroticism.

In terms of relation to the object—the mother—from the point of view of the child, never gave enough milk; it is “as though they had never sucked long enough at their mother’s breast,” said Freud in his article, “Female Sexuality” (1931b, p. 234). Taking up the conclusions of Karl Abraham of 1924, Freud conceived of two stages in the oral phase, one pre-ambivalent regarding the breast, the second oral-sadistic; linked to the development of dentition and characterized by the appearance of ambivalence, which will be intensified in the following phase, that of anal-sadism (1933a).

Melanie Klein would later connect an oral fixation, in both sexes, to sucking the father’s penis, with the exacerbated phase of sadism.

DOMINIQUE J. ARNOUX

*See also:* Anal-sadistic stage; Anorexia nervosa; *Basic Neurosis, The-oral regression and psychic masochism*; Breast-feeding; Bulimia; Depression; Dream screen; Drive, partial; Erotogenicity; Libidinal stage; Melancholy; Oedipus complex, early; Orality; Pregenital; Psychosexual development; Stammering; Sucking (oral stage) Transitional object; Transitional object, space; Weaning.

### Bibliography

- Abraham, Karl. (1924). The process of introjection in melancholia: Two stages of the oral phase of the libido. In *Selected papers in psychoanalysis*. (Douglas Bryan and Alix Strachey, Trans.). London: Hogarth Press.
- . (1924). Melancholy and obsessional neurosis: Two stages of the anal-sadistic phase of the libido. In *Selected papers in psychoanalysis* (Douglas Bryan and Alix Strachey, Trans.). London: Hogarth Press.
- Freud, Sigmund. (1905d). Three essays on the theory of sexuality. *SE*, 7: 123–243.
- . (1916–1917g). Mourning and melancholia. *SE*, 14: 237–258.
- . (1920g). Beyond the pleasure principle. *SE*, 18: 1–64.
- . (1924c). The economic problem of masochism. *SE*, 19: 155–170.
- . (1931b). Female sexuality. *SE*, 21: 221–243.
- . (1933a). New introductory lectures on psychoanalysis. *SE*, 22: 1–182.
- . (1950a). Extracts from the Fliess papers. *SE*, 1: 173–280.
- Klein, Melanie. (1932). *The psychoanalysis of children*. London: Hogarth.

---

## EROTICISM, URETHRAL

Urethral eroticism is characterized by pleasure associated with micturition (or urination). In “Character and Anal Erotism” (1908b), Freud wrote, “We ought in general to consider whether other character-complexes, too, do not exhibit a connection with the excitations of particular erotogenic zones. At present I only know of the intense ‘burning’ ambition of people

who earlier suffered from enuresis" (p. 175). In "Fragment of an Analysis of a Case of Hysteria" (1905e [1901], p. 74), Freud emphasized the pleasure and erotic significance of micturition and considered enuresis as equivalent to masturbation. In his *Three Essays on the Theory of Sexuality* (1905d), he specified that urethral eroticism occurs more particularly in the "second phase of infantile masturbation," the phallic phase.

In "Character and Anal Erotism" (1908b), Freud returned to the idea that enuresis is the source of intense ambition. The character traits that persist are either the unchanged continued primal drives or their sublimation, or reaction formations that conflict with primal drives. Freud emphasized the connections between urethral eroticism and ambition in *Civilization and Its Discontents* (1930a [1929]) and between fire and genital eroticism in "The Acquisition and Control of Fire" (1932a).

In "The Narcissistic Evaluation of Excretory Processes in Dreams and Neurosis" (1949), Karl Abraham later pursued a similar line of thought when he noted that subjects inclined to urethral eroticism have a sense of unlimited power, believing that they can create or destroy any object.

In "Early Stages of the Oedipus Conflict" (1928), Melanie Klein emphasized a specifically urethral form of sadism in which fantasies contribute to difficulties of sexual potency in men and unconsciously help attribute a cruel role to the penis.

DOMINIQUE J. ARNOUX

See also: Enuresis (bedwetting); Oedipus complex, early; Wish for a baby.

### Bibliography

- Abraham, Karl. (1949). The narcissistic evaluation of excretory processes in dreams and neurosis. In *Selected papers of Karl Abraham, M.D.* (Douglas Bryan and Alix Strachey, Trans). London: Hogarth Press and the Institute of Psycho-analysis. (Original work published 1920)
- Freud, Sigmund. (1905d). Three essays on the theory of sexuality. *SE*, 7: 123–243.
- . (1905e [1901]). Fragment of an analysis of a case of hysteria. *SE*, 7: 1–122.
- . (1908b). Character and anal erotism. *SE*, 9: 167–175.
- . (1930a [1929]). Civilization and its discontents. *SE*, 21: 57–145.

———. (1932a [1931]). The acquisition and control of fire. *SE*, 22: 183–193.

Klein, Melanie. (1928). Early stages of the Oedipus conflict. *International Journal of Psycho-Analysis*, 9, 167–180.

### Further Reading

Bass, Alan. (1994). Aspects of urethrality in women. *Psychoanalytic Quarterly*, 63, 491–517.

---

## EROTOGENIC MASOCHISM

Erogenic masochism is the primary, biological, and constitutional masochism that results from libidinal excitation, which provides the physiological basis. It is the psychic superstructure that supports the other forms of masochism, feminine and moral, that Freud described along with it in "The Economic Problem of Masochism" (1924c).

In *Three Essays on the Theory of Sexuality* (1905d) Freud noted that "it may well be that nothing of considerable importance can occur in the organism without contributing some component to the excitation of the sexual instinct" (pp. 204–205). Earlier, he had specified that in the case of pain, in particular, a quantitative factor was added to the qualitative factor characteristic of the erotogenic zones.

Freud explained in "The Economic Problem of Masochism" that erotogenic masochism, as "pleasure in pain," subverts the pleasure principle, which would otherwise tend toward the zero excitation characteristics of the Nirvana principle and would be "entirely in the service of the death instincts" (p. 160). He further elaborated that the portion of the death instinct that the libido has not diverted outward toward objects remains inside the organism and "with the help of the accompanying sexual excitation . . . becomes libidinally bound there. It is in this portion that we have come to recognize the original, erotogenic masochism" (pp. 163–64). It is thus vestigial evidence of the earliest fusion of the instincts, which, by a kind of assimilation, binds the essential core of the death instinct that continually threatens the individual's existence.

According to Freud in this essay, erotogenic masochism is present in all of the developmental phases of the libido: the oral stage, as manifested in the "fear of being eaten up by the totem-animal (father)" (p. 165);



the anal-sadistic stage, especially with the erotogenic role of the buttocks (the wish to be beaten by the father); the phallic stage, as shown by the traces of (disavowed) castration in masochistic fantasies; and finally the genital stage, in “characteristically female” situations, namely, “being castrated, or copulated with, or giving birth to a baby” (p. 162).

It can be noted that in this libidinal sequence, Freud mentioned only the father as the object of masochistic desire, including during the oral stage, when this is manifested in the form of a defense—the fear of being devoured—whereas it is the wish to be beaten that is used as an example for the following stage. This attests to Freud’s difficulty in conceptualizing early relations, including masochistic ones, with the mother. However, the fact that he was dealing with early developmental stages is not what caused the difficulty, as he did not hesitate at the time, in 1924, to posit erotogenic masochism as being primary in psychic life.

Melanie Klein did not concur with this explanation, which construed anxieties about being devoured in terms of an erotogenic masochism that would cause the subject to wish for them. Given her emphasis on projection onto an object, conceived as present almost from the outset—and despite both her taste for the archaic and her agreement with the second theory of the instincts—she theorized them as anxieties about retaliation for oral sadism, in a view that is thus closer to secondary masochism, the existence of which, moreover, Freud recognized.

DENYS RIBAS

*See also:* Masochism.

### **Bibliography**

Freud, Sigmund. (1905d). Three essays on the theory of sexuality. *SE*, 7: 123–243.

———. (1924c). The economic problem of masochism. *SE*, 19: 155–170.

---

## **EROTOGENIC ZONE**

Any part of the body susceptible of becoming excited, of being a seat of pleasure, is an erotogenic zone. Freud nevertheless used the term to refer primarily to a num-

ber of specific areas, notably, the genitals, mouth, and anus. These zones he saw as locations of particular instincts known as “component instincts.” In neurosis, on his account, nongenital erotogenic zones come to function as substitutes for the genitals. The idea of erotogenic zones was inseparable from the theory of libidinal stages, each of which, at a certain age, is fixed upon a particular zone.

Freud found support in the work of the pediatrician S. Lindner for his assertion that the child pursues the kind of sucking that develops anaclitically from feeding at the breast, for the pleasure obtained from excitation of the oral erotogenic zone. “The child’s lips, in our view, behave like an erotogenic zone, and no doubt stimulation by the warm flow of milk is the cause of the pleasurable sensation” (1905d, p. 181). Sexual activity centered on an erotogenic zone rests first on its utility for self-preservation but is subsequently repeated independently of that function. Erotogenic zones are thus seen as the source of the sexual instinct, its place of origin, and (for the appropriate instinct) its place of residence.

Freud nevertheless broadened his definition of an erotogenic zone well beyond its original link with a bodily function, noting that “any other part of the skin or mucous membrane can take over the functions of an erotogenic zone, and must therefore have some aptitude in that direction” (1905d, p. 183). An area may be affected by chance as the child explores the body and discovers its potential for pleasure through an association with the simultaneous pleasure of sucking. For the adult who represses the sexual nature of the genitals, this opens up the regressive possibility of instating any part of the body as an erotogenic zone. In this case, hysterogenic zones present the same characteristics as erotogenic ones.

How is pleasure produced at the level of the erotogenic zone? The pressure of the need for satisfaction, which is of central origin, is projected outward, stimulating a peripheral erotogenic zone, whose manipulation, in a manner analogous to sucking on the breast, relieves the feelings aroused and so generates satisfaction. The erotogenic zone may also be stimulated directly, in which case it by itself creates a need, which, to be satisfied, calls for further stimulation of the zone in question.

Each particular erotogenic zone (the mouth, anus, genital organs) is wedded to a habitual stimulation

that will vary according to the life stage reached. Like the labial zone before it, the anal zone is eroticized by means of an anaclitic dependence on a corresponding bodily function, in this case excretion. The genital zone (the penis in the case of a boy, the clitoris in that of a girl) first becomes erotogenic through an anaclitic relationship with the function of micturition, the first sexual excitation of this zone constituting the point of departure for a normal sexual life. Freud (1908b) associated specific character types with adult fixations on the erotogenic nature of this or that zone.

The sexual life of early childhood is not confined to the stimulation of erotogenic zones, for so-called component instincts can emerge independently of those zones. The instinct to see and be seen, even though it is not autoerotic in nature and calls for an outside object, may turn the eye into the equivalent of an erotogenic zone. Likewise, the cruelty component of the sexual instinct, which seems at first even more independent of the erotogenic zones, is in fact linked to the instinct for mastery and to the musculature. By contrast, the skin of the buttocks, because of the chastisements it so often receives, can easily become an erotogenic zone and the site of passive masochistic pleasure.

With the introduction of narcissism, Freud added an important dimension to the theory of erotogenic zones by joining it with the ego-libido: "We can decide to regard erotogenicity as a general characteristic of all organs and may then speak of an increase or decrease of it in a particular part of the body. For every such change in the erotogenicity of the organs there might then be a parallel change of libidinal cathexis in the ego" (1914c, p. 84). The withdrawal of libido into the ego and the libido's cathexis of organs, as erotogenic zones now become painful and sensitive, may be thought to underlie hypochondria, and in such cases of hypochondria, health can be restored only by redeploing libido to objects external to the subject's own body.

The erotism aroused in these zones is essentially polymorphous in the young child. Save in the case of perversion, the child's erotism is later unified under the primacy of the genital zone, but the fate of this infantile sexuality varies: repressions, reaction-formations, and sublimations come into play as ways of dealing with the excitations emanating from the erotogenic zones, excitations that are normally unusable, or largely unusable, for the adult. In such cases, the instinctual object of the drive is often modified. Sándor Ferenczi (1916) showed, for instance, that an interest in money was founded on

the anal erotogenic zone and the possibility of establishing a symbolic link between feces and money.

In this light, and in view of the potentially infinite number of transformations of instincts deriving from the erotogenic zones, it is fair to say that any form of human activity might be attributable to erotogenic sources. The psychoanalytic theory of the erotogenic zones appears to fall under the rubric of autoerotism, for it is the component instincts, independent of these zones, that are said to be directed straight at the object. Yet, as has often been pointed out, it would seem impossible to dissociate the emergence of these multiple erotogenic zones from pleasure-generating encounters with the object, especially in the context of maternal care.

It is worth mentioning that theorists since Freud have considered other erotogenic zones, such as those that affect the functions of respiration and hearing.

SOPHIE DE MIJOLLA-MELLOR

*See also:* Anaclisis/anaclitic; Anality; Anal-sadistic stage; Autoerotism; Body image; Breastfeeding; Character formation; Cruelty; Drive/instinct; Erotogenicity; Eroticism, oral; Exhibitionism; Feminine sexuality; Libidinal stage; Libido; Masochism; Masturbation; Maternal; Object, choice of/change of; Oedipus complex; Orality; Organization; Organ pleasure; Pictogram; Progenital; Primary object; Psychosexual development; Sexuality; Skin; Stage; *Three Essays on the Theory of Sexuality*.

### **Bibliography**

- Ferenczi, Sándor (1916). Stages in the development of the sense of reality. In his *Contributions to psycho-analysis*. Boston: Richard Badger.
- Freud, Sigmund. (1905d). Three essays on the theory of sexuality. *SE*, 7: 123–243.
- . (1908b). Character and anal erotism. *SE*, 9: 167–175.
- . (1914c). On narcissism: An introduction. *SE*, 14: 67–102.

---

## **EROTOGENICITY**

The term *erotogenicity* designates the capacity of any part of the body, whether muco-cutaneous surfaces or internal organs, to become the site of sexual excitation.

Rarely used by Freud, the term first appeared in "On Narcissism: An Introduction." (1914c) Freud

wrote: "Let us now, taking any part of the body, describe its activity of sending sexually exciting stimuli to the mind as its "erotogenicity," and let us further reflect that the considerations on which our theory of sexuality was based have long accustomed us to the notion that certain other parts of the body—the "erotogenic" zones—may act as substitutes for the genitals and behave analogously to them. We have then only one more step to take. We can decide to regard erotogenicity as a general characteristic of all organs and may then speak of an increase or decrease of it in a particular part of the body. For every such change in the erotogenicity of the organs there might then be a parallel change of libidinal cathexis in the ego" (p. 84).

This term *erotogenicity*, or *erogeneity*, appeared contemporaneously with a conceptual change whereby Freud partitioned the libido (into the ego libido and narcissistic libido), this being indispensable in order to explain the processes at work in the psychoses, the "actual neuroses" (particularly hypochondria), and love life. This energetic and quantitative meaning of erotogenicity is directly linked to the concepts of libido, ego, and object. It would thus modify though not replace the qualitative conception of the erogenous zones from which it derived and which were previously defined as the sources of the autoerotic component instincts (partial drives).

Freud very early recognized the sexual excitability (*Erregbarkeit*) of certain parts of the body apart from the genital zones, in the strict sense, and referred to these as *erogenous zones*. This expression is derived from Charcot's *hysterogenic zones*, a term used to designate "more or less delimited regions of the body, on which pressure or merely rubbing determines, more or less rapidly, the phenomenon of the aura, which is sometimes succeeded, if we continue to apply pressure, by an hysterical attack. These points, or rather these surfaces, also have the property of being the seat of permanent sensitivity." (Charcot, 1890). When speaking of the case of Elisabeth von R. in *Studies on Hysteria*, Freud extended the meaning of *hysterogenic zone* by giving it its full value as a corporal inscription of a mnemonic trace and describing the sexual pleasure within the conversion symptom. Elisabeth von R's pains always started from a particular point on the right thigh and the analysis revealed that her father used to rest his leg there when she was caring for him. Freud states: "In this way she gave me the explanation that I needed of the emergence of what was an atypical

hysterogenic zone" (1895d, 148). The notion of hysterogenic zone came to be modified between Charcot and Freud because it now meant a place with a sexual "stimulability" (*Reizbarkeit*) that was determined by the subject's history and not by anatomy.

The equivalence between erogeneity and hysterogeneity is clearly defined in two of Freud's letters to Wilhelm Fliess, one dated December 6, 1896, in which the term *erogenous zone* appears for the first time, the other dated November 14, 1897, in which he wrote: "I have often suspected that something organic played a part in repression; I have told you before that it is a question of the attitude adopted to former sexual zones. . . . We must suppose that in infancy sexual release is not so much localized as it becomes later, so that zones which are later abandoned (and possibly the whole surface of the body) stimulate to some extent the production of something that is analogous to the later release of sexuality" (p. 232). These sexual zones that are abandoned in the course of development constitute infantile sexuality proper, and are recathected in perversions and neuroses. In *Three Essays* Freud shows that through the action of displacement and condensation these erogenous zones "then behave exactly like the genitals (1905d, p. 183) and produce the symptoms that are conceived of as substitutes for sexual satisfaction. The paradigm is that of hysteria: "erotogenic and hysterogenic zones show the same characteristics" (1905d, p. 184).

He then goes on to describe the development phases of infantile sexual organization (oral, anal, and phallic). The erogenous zones are the source of the component sexual impulses that seek autoerotic satisfaction until they are subordinated to and take part in genital activity. Freud's model for the excitation of the erogenous zones is based on the erection, including the tension (unpleasure) it mobilizes, and the demand for discharge (pleasure) that it prescribes. The fact that certain parts of the body are predestined to be erogenous is explained by the Freudian concept of *anaclysis*. The term is used to designate the relationship of leaning and implication that exists between the sexual instincts and the needs of self-preservation. For example, Freud postulates for the oral instinct that, "the satisfaction of the erotogenic zone is associated, in the first instance, with the satisfaction of the need for nourishment" (1905d, p. 181).

Without recanting on this theory of erogenous zones as presented above, Freud modified his concep-

tion of erogeneity in 1914 toward an energy-based and quantitative model where the hysteria paradigm is replaced by that of hypochondria. It was now the whole body that behaved like a male genital organ. The distribution of the libido and its capacity to go beyond the frontiers of narcissism conditioned suffering and love equally.

*Inhibition, Symptoms and Anxiety* (1926d) describes the relationship between the ego-function of an organ and erogeneity: “It has been discovered as a general fact that the ego-function of an organ is impaired if its erotogenicity—its sexual significance—is increased. It behaves, if I may be allowed a rather absurd analogy, like a maid-servant who refuses to go on cooking because her master has started a love-affair with her” (pp. 89–90). Freud gives other examples of inhibitions following a risk of conflict between the ego and the superego, as when profit and success are prohibited and when failure satisfies a need for self-punishment. Thus, in the second theory of the instincts erogeneity is equivalent to a libidinal satisfaction that can be accomplished up to and including self-punishment and self-destruction as in, for example, moral masochism.

The Freudian notion that erogenous activity is anaclitic in relation to the satisfaction of the fundamental needs of self-preservation favored the theoretical illusion of a progressive organization of instinctual stages with maturation being almost biologically determined. This conceptual model compromises the importance of the Other and its constitutive intervention in infantile sexuality. By referring to anaclysis in another sense, the choice of love object being based on the model of the mother who feeds or the father who protects, Freud’s 1914 text introduces another perspective, but not without some hesitation and aporia.

Jacques Lacan (1964-1966) developed a theoretical model that denies the genetic point of view of instinctual stages and its “naturally” programmed organization. He writes: “There is no relation of engendering between one component instinct and the next,” and states: “The passage from the oral instinct to the anal is not produced by a process of maturation but by means of the intervention of something that has nothing to do with instincts—by the intervention, the reversal, of the demand of the Other.”

Serge Leclaire (1968) demonstrated that erogeneity depends closely on the “sexual value” projected onto the

child’s body by another. The mother who caresses her child’s dimple with her finger inscribes a difference there, a flaw, a point of focus, an erogenous center: “What makes the erotogenic inscription possible is the fact that the caressing finger is itself, for the mother, an erotogenic zone. This finger, in its essential libidinal value, can be called a “letter-holder” or inscriber to the extent that, as an erotogenic zone of the mother, a letter fixes into its flesh the interbal of an exquisite difference” (p. 50).

ROLAND GORI

*See also:* Erotogenic zone; Fetishism; Hypochondria; Inhibition; Libidinal development; Organ pleasure.

### **Bibliography**

- Charcot, Jean Martin. (1890). *Oeuvres complètes. Leçons sur les maladies du système nerveux*. Paris: Progrès Médicale.
- Freud, Sigmund. (1895d). Studies on hysteria. *SE*, 2: 48–106.
- . (1905d). Three essays on the theory of sexuality. *SE*, 7: 123–243.
- . (1914c). On narcissism: An introduction. *SE*, 14: 67–102.
- . (1914d). On the history of the psycho-analytic movement. *SE*, 14: 1–66.
- . (1926d). Inhibitions, symptoms and anxiety. *SE*, 20: 75–172.
- Lacan, Jacques. (1966). Position de l’Inconscient. *Écrits*. Paris: Seuil. (Original work published 1964)
- Leclaire, Serge. (1999). *Psychoanalyzing: on the order of the unconscious and the practice of the letter*. (Peggy Kamuf, Trans.). Stanford, CA: Stanford University Press. (Original work published 1968)

---

## **EROTOMANIA**

Erotomania, the “delusion of being loved,” is a morbid fascination that is clinically classified as a form of delusion, accompanied by insistent demands and jealousy. Emil Kraepelin associates it with the paranoid psychoses and Sigmund Freud interprets it psychoanalytically (1911c [1910]). For Freud the inverse projection of erotomania serves as a defensive function against latent homosexuality:

Another element is chosen for contradiction in *erotomania*, which remains totally unintelligible on

any other view: 'I do not love *him*—I love *her*.' And in obedience to the same need for projection, the proposition is transformed into: 'I observe that *she* loves me.' 'I do not love *him*—I love *her*, because SHE LOVES ME.' Many cases of erotomania might give an impression that they could be satisfactorily explained as being exaggerated or distorted heterosexual fixations, if our attention were not attracted by the circumstance that these infatuations invariably begin, not with any internal perception of loving, but with an external perception of being loved. But in this form of paranoia the intermediate proposition 'I love *her*' can also become conscious, because the contradiction between it and the original proposition is not a diametrical one, not so irreconcilable as that between love and hate: it is, after all, possible to love *her* as well as *him*. It can thus come about that the proposition which has been substituted by projection ('*she loves me*') may make way again for the 'basic language' proposition 'I love *her*' (1911c [1910], pp. 63–64).

The initial core can be traced back to the narcissistic root through idealization (projection of the subject's ideal ego), split personality, and double bind situations.

In 1920 Gatian de Clérambault defined his conception of erotomaniac delusion in a letter to the Société Clinique de Médecine Mentale (Clinical society of mental medicine) as the "coexistence of two delusions: persecution and erotomania." In 1921 he isolated "pure erotomania" within the context of emotional delusion. This emotional syndrome, which is generated by feelings of pride, desire, and hope, revolves around a "fundamental postulate": "It is the object that began and that loves the most or that loves alone." This revelation, generally found in women, initiates the phase of hope. A number of topics are derived from this, for example, the belief that "the object cannot experience happiness without being loved." From then on their protection, their efforts at closeness, and indirect manifestations of their love are combined with paradoxical behavior patterns. Interpreted as hardships and especially as demonstrations of love, they appear as persecutory during the stages of spite and bitterness that are part of a chronic, persistent development. The associated erotomania is a fluid entity, an expression of a paranoid, a schizophrenic psychiatric condition.

In spite of our clinical (found in DSM IV) and psychopathological understanding, there have been few

therapeutic advances for such patients, who are often intrusive and consequently rarely succeed in attracting attention for very long.

MICHEL DEMANGEAT

*See also:* Delusion; Mathilde, case of; Paranoia; Passion; Persecution; "Psycho-Analytic Notes on an Autobiographical Account of a Case of Paranoia (Dementia Paranoides)"; Psychoses, chronic and delusional.

### Bibliography

- Demangeat, Michel. (1999). *Historisation et structure dans les névroses passionnelles*. Bordeaux: Cahiers de Trait.
- Freud, Sigmund. (1911c [1910]). Psycho-analytic notes on an autobiographical account of a case of paranoia (dementia paranoides). *SE*, 12: 1–82.
- Clérambault, Gatian de, and Brousseau, Albert. (1987). Coexistence de deux délires: Persécution et érotomanie (présentation de malades). In *Œuvres psychiatriques* (p. 323). Paris: Frénésie. (Reprinted from Bulletin de la Société clinique de médecine mentale Dec. 1920.)
- Perrier, François. (1967). L'érotomanie. In P. Aulagnier-Spairani et al., *Le Désir et la Perversion* (p. 129–162). Paris: Le Seuil.
- Rosolato, Guy. (1980). Clérambault et les délires passionnels. *Nouvelle Revue de psychanalyse*, 21, 199–213.

## ERYTHROPHOBIA (FEAR OF BLUSHING)

Erythrophobia or ereuthrophobia describes a pathological fear of blushing in public.

In the Minutes of the Psychoanalytical Society of Vienna (Nunberg and Federn, 1962–75) the session of February 3, 1909, was devoted to "A case of compulsive blushing" presented by Alfred Adler in the presence of Freud, Paul Federn, Max Graf, Edouard Hitschmann, Albert Joachim, Otto Rank, Isidor Sadger, and Fritz Wittels.

According to Freud, we cannot classify this state among the sexual neuroses because it is situated somewhere between anxiety hysteria and paranoia. These two assertions are to be found in the comments he made after Adler's conference: "Erythrophobia consists of being ashamed for unconscious reasons [...]. The first thing these patients were ashamed of was usually masturbation; more generally, the secret of their precocious knowledge with regard to sexuality."

And: “Neuroses cannot be expressed with a single current but only by a pair of opposites which are shame and rage in this case. Only the coexistence of these active and passive current explains the case of erythro-phobia: it is the meeting of these two currents that produces the attack.”

Ernest Jones, for his part, distinguished between “ereuthrophobia,” the fear of blushing, and “erythro-phobia” or fear of the color red (1913).

BERNARD GOLSE

*See also:* Phobias in children; Phobic neurosis.

### **Bibliography**

Jones, Ernest. (1913). Pathology of morbid anxiety. *Papers on Psychoanalysis*. London: Bailliere, Tindall & Cox, 1918.

Nunberg, Hermann; and Federn, Ernst. (1962–75). Minutes of the Vienna Psychoanalytic Society. New York: International Universities Press.

## **ESSENTIAL DEPRESSION**

The notion of *essential depression* was introduced by Pierre Marty in his 1966 article “La dépression essentielle,” shortly after the notion of “operative thought,” and it became a clinical construct in the treatment of psychosomatic disorders. The term *essential depression* emerged after “depression without an object” and is a more appropriate name than the latter because the phenomenon it describes constitutes the very essence of depression.

Essential depression involves a reduction in the level of both object-libido and narcissistic libido, without any positive economic counterpart, and thus without any libidinal connection at the relational level; this distinguishes it from other depressions of the neurotic or even psychotic type. This specificity of the relational mode with the investigator, an analogue for the overall relational mode, indicates a diagnosis of this type of depression, which can be difficult to detect. Everything seems to take place without visible emotion, flattening any underlying drama or internal conflict. This absence of any nameable affect is comparable to the hypothesis of alexithymia: We find something like an erasure of the dynamic capacities of the basic mental functions across the entire spectrum—the absence of any vital link gives the impression of a functional breakdown. According to

Marty, this abrasion of libidinal bonds and impression of fragmentation constitute the very definition of the death instinct (it should be recalled that Marty envisions the death instinct as a deficiency of individual movements of life without the opposing destructive charge carried by the death instinct as theorized by Sigmund Freud). However, adds Marty, “although essential depressives thus seem always to carry phenomena of death within themselves, the libido seems to be extinguished only when life is extinguished, except in certain rare cases.” In such cases, he contends, the ego ceases to exist as an agency within the psychic apparatus.

Marty subsequently introduced this clinical construct into his work as a pivotal notion, along with “operative thought”—all within the framework of “disorganization” that is part of his model of the somatization process. His most extensive account is found in *Les mouvements individuels de vie et de mort. Vol. 2: L'Ordre psychosomatique* (Individual movements of life and death. Vol. 2: The psychosomatic order; 1980), where he emphasizes one of the main signs of essential depression: The disappearance of unconscious feelings of guilt in an ego that only poorly fulfills its roles of linking, distribution, and defense. He once again underscores the fragility of the preconscious at this stage. The deficit of this symptom is thus situated within the psyche, and somatic disturbances are the result within a system that is defensive and yet disorganizing in response to trauma. He theorizes that this phase is preceded by an automatic, diffuse anxiety that is related to anxiety neurosis, which for its part cannot be understood as an alarm signal that should trigger the mental defenses. In the first volume of *Les mouvements individuels de vie et de mort*, subtitled *Essai d'économie psychosomatique* (Essay on psychosomatic economy; 1976), Marty hypothesizes that the passage into essential depression occurs through depletion of the “anxiety apparatus” at the expense of psychic functioning.

ALAIN FINE

*See also:* Character neurosis; Depression; Disintegration, feelings of, (anxieties); Disorganization; Mentalization; Negative, work of the; Operational thinking; Psychosomatic.

### **Bibliography**

Marty, Pierre. (1966). La dépression essentielle. *Revue française de psychanalyse*, 30, 5–6.

———. (1976). *Les mouvements individuels de vie et de mort. Vol. 1: Essai d'économie psychosomatique*. Paris: Payot.

———. (1980). *Les mouvements individuels de vie et de mort. Vol. 2: L'Ordre psychosomatique*. Paris: Payot.

## ESTRANGEMENT

The term *estrangement* connotes an idea of novelty or even bizarreness. Freud, in his essay “The Uncanny” (1919h), added an additional meaning when he emphasized that this feeling, an experience close to a sensation, is at its peak when it is triggered by the reappearance of a familiar object that has been forgotten or repressed for a long time. The feeling of estrangement can be compared to the phenomena of *déjà vu* or *déjà vécu* (previously lived). Although the concept is developed in *The psychopathology of everyday life* (Freud, 1901), it is referred to as such only in his short essay “A Disturbance of Memory on the Acropolis” (Freud, 1936a).

The concept of estrangement has been extensively described in classical psychiatry, which views it as a delusion associated with the inability to recognize a known object or person. Pierre Janet considered estrangement to be a disturbance of the reality function and a breakdown in the process of mental synthesis. Freud, however, distinguished such phenomena (which he also studied) from those described in the literature, where uncertainty about the nature of objects (living or dead, human or automata) is voluntarily maintained to create in the reader a feeling of anxiety, a sense of the uncanny.

Starting from Friedrich Schelling's idea that the feeling of estrangement arises from exposure to something that is revealed but should have remained hidden, Freud went on to stress the return of the repressed. In terms of symptoms, the feeling of estrangement appears as an anxiety that something is about to be revealed. It can be seen as a form of transgression, like crossing to the other side of an imaginary line without knowing how or why one got there. This transgression is not only prohibited by the superego but is associated with the subject's identity and simultaneously concerns the limit between internal and external, the limits among past, present, and future, and the limit between life and death. The feeling of estrangement is associated with a mysterious imaginary time before life, which is therefore

unrecognizable and yet insists on revealing its familiarity.

Freud had already developed these ideas in *Totem and Taboo* (1912–1913a). There he wrote that what is felt as strange in the outside world initially belonged to the self and was then projected to the exterior. The nonself, the object of perception, is only recognizable through this process of projection (an animist conception of the world). This feeling of estrangement is also related to the dialectic between the strange and the familiar among the dead, who are not completely separated from the living but rather continue to hover around them (the taboo against the dead).

The psychoanalytic feeling of estrangement arises from a sudden confrontation between a perception of the outside world and repressed primitive internal perceptions. These internal perceptions are not apprehended as such and appear in the subject's mental space only after having been projected onto the outside world. Consequently, they are bound to the objects that support them. This crossing of a limit, whether it involves the before or after, the animate or inanimate, the internal or external, is always associated with the death drive, whose final goal is the initial state—an expression of the inertia of organic life.

In “A Disturbance of Memory on the Acropolis” (1936a), Freud, deepening and restricting the feeling of estrangement, saw it essentially as a defense mechanism that attempts to distance something from the ego (depersonalization) or include something external (false recognition, *déjà vu*, previously narrated). The oedipal explanation of Freud's disturbance of memory (guilt for surpassing his father, realization of his desire to escape his family) does not cover all there is to estrangement.

The feeling of estrangement, which is so difficult to grasp, is an inherent part of psychoanalysis itself when it attempts to revivify repressed contents. It is associated with what Freud defined in *Beyond the Pleasure Principle* (1920g) as the demonic, which characterizes the repetition compulsion. To a considerable extent, it has the characteristics of a drive, yet it is hostile to the pleasure principle. In a sense, estrangement, in its unconscious dimension, may impose limits on our understanding, like an iceberg, which remains largely submerged.

SOPHIE DE MIJOLLA-MELLOR

See also: Certainty; Déjà vu; Depersonalization; “Disturbance of Memory on the Acropolis, A”; Double, the; Premonitory dream; Ego; German romanticism and psychoanalysis; Illusion; Phantom; Repetition; Secret; Self-consciousness; Telepathy; “Uncanny, The”.

### Bibliography

- Freud, Sigmund. (1901b). *The psychopathology of everyday life*. SE, 6.
- . (1912–1913a). Totem and taboo. SE, 13: 1–161.
- . (1919h). The uncanny. SE, 17: 217–256.
- . (1920g). Beyond the pleasure principle. SE, 18: 1–64.
- . (1936a). A disturbance of memory on the Acropolis. SE, 22: 239–248.

## ETHICS

Ethics concerns mores: human moral attitudes in general and, more specifically, rules of behavior and their justifications. This system of rules attributes values to behaviors by judging them to be good or bad according to their intrinsic moral qualities or their concrete social consequences. For Freud, ethics takes up where totemism and taboos leave off, and constitutes the basis of all religion.

In *Civilization and Its Discontents* (1930a [1929]), Freud noted, “The cultural super-ego has developed its ideals and set up its demands. Among the latter, those which deal with the relations of human beings are comprised under the heading of ethics” (p. 142).

As early as the *Studies on Hysteria* (1895a), Freud analyzed hysterical conversion symptoms as the result of a conflict between patients’ erotic thoughts and moral ideals. The adjective “ethical,” *ethisch* in German, appeared for the first time in 1898 in “Sexuality in the Aetiology of the Neuroses.” In that essay, Freud raised the question of whether physicians have the right to intrude into the sexual lives of their patients and whether their “ethical duty” might not be “to keep away from the whole business of sex” (p. 264).

The notion of ethics in Freud’s work refers primarily to those moral ideals in the name of which individuals renounce any instinctual impulses that are irreconcilable with the narcissistic ideals of the ego. These ideals are based on images of loved objects and the

esteem of the superego. For Freud, the symptoms of the transference neuroses were substitutes for the remains of old loves that were forbidden by morality.

The reign of “civilized morality” begins when the drives are renounced. This forms the basis of religion and culture. Yet when individuals renounce the drives, they are deprived of the sexual and aggressive satisfactions demanded by the id, and so run the risk of neurosis.

This traditional conception of ethics is emphasized when the German word *Ethik* is translated as *morals* or *morality*. In what Angélo Hesnard calls “the morbid universe of guilt,” the unconscious feelings of guilt that cause neurotic symptoms do not relate to the material reality of the patient’s actions. Neurotic patients are guilty only of their secret intentions. The psychic reality of the forbidden and repressed wishes of “the child that is in man” (Freud, 1910a [1909], p. 36) is accessible to us by dream interpretation and is realized in the course of analytic treatment in the love/hate relationship of the transference. And yet, by reawakening the demons banished by morality, does not psychoanalysis run the risk of destroying the very foundations of culture, which always demands sacrifices of the individual?

This question leads to another conception of ethics, one that is specific to psychoanalysis. The ethics of psychoanalysis is a consequence of how its practice implements its method and rules. Psychoanalysis does not aim to make the individual adapted to his or her environment. In other words, it does not serve the good; rather, it seeks the truth. When Freud recommended that physicians not give in to the amorous advances of their patients, he was giving voice less to traditional morality than to a psychoanalytic ethics conceived in terms of the requirements of a praxis founded on a method. The patient, by engaging in transference love, aggravated by a resistance to remembering, aims to reduce the analyst to a lover. The analyst is ethically bound not to respond, because he does not mistake the transference for true love. He wants to frustrate the analysand’s love so that it can be analyzed. Otherwise, the analyst would become allied with the resistance. Here moral motives converge with psychoanalytic technique.

This psychoanalytic notion of ethics serves philosophical, religious, and moral causes. In *Moses and Monotheism* (1939a), Freud showed that ethics originates in “a sense of guilt felt on account of a suppressed hostility to God” (p. 134). Using Judaism, he



returned to the myth of the murder of the father that he developed in *Totem and Taboo* (1912–1913a). Freud argued that people have always known that at one time they had a primitive father (which in religion becomes the godhead) and that they put him to death. The resulting “nostalgia for the father” reflected an insatiable need to appease a sense of guilt by changing the father’s prohibitions into ethical obligations. When sons ingest the dead father’s body, they come to identify with someone whom they simultaneously love and hate. Thus, the dead father becomes the superego, demanding self-sacrifice. When the subject obeys the superego and renounces his sexual and aggressive impulses, he can both hate and love the parental authority within himself.

Freud revealed the role that masochism and narcissism play when the drives are reined in by ethics. A subject who suffers by sacrificing his or her desires to the supposed demands of the Other feels loved and chosen by this Other while unconsciously reproaching the Other for sadism.

Jacques Lacan discussed how the death drive functions in the dialectic between the pleasure principle and the reality principle. He began by declaring the prohibition of incest to be the only universal law. All other rules of morality are merely historical and cultural variations of this law. Desire for the mother can never be satisfied, even after the murder of the deterring father, because acting out incest would cause the social order to collapse. For this reason, the “naturalist liberation” of pleasure fails (Lacan, p. 4), *jouissance* remains forbidden, and the prohibition is reinforced by the work of mourning. The human condition is tragic because the more the subject renounces pleasure, the more his superego demands greater sacrifices. Nevertheless, the superego is necessary to produce the economy of pleasure and to introduce desire into the world of symbolic mediation.

In the character of Antigone, Lacan found an incarnation of a “pure and simple desire for death” (p. 282). This “raw,” “inflexible” “kid” (pp. 250, 263) opposes the ethics of the good, represented by Creon. With her sacrifice, Antigone becomes the pure and simple relation between being human and “the break introduced by the presence of language in the human life” (p. 279). The result is that “when an analysis is carried through to its end the subject will encounter the limit in which the problematic of desire is raised” (p. 300).

Jacques Lacan emphasized the human subject’s debt to language in becoming human and thus proposed a psychoanalytic ethic that did not concern itself with happiness and the good. The idealization of the figure of Antigone produced a Hegelian imperative to “pure action” that could conceivably be added to or substituted for traditional ethico-religious ideals. What Patrick Guyomard refers to as “the enjoyment of the tragic” must give way to the specific requirements of psychoanalytic work, a work of mourning that, according to Conrad Stein, leads to a “crossing of the tragic.” Thus the ethics of psychoanalysis is a consequence of its specific method.

ROLAND GORI

*See also:* Boundary violations; Criminology and psychoanalysis; Judgment of condemnation; Kantianism and psychoanalysis; Seminar, Lacan’s; Transgression; Truth.

### Bibliography

- Freud, Sigmund. (1898a). Sexuality in the aetiology of the neuroses. *SE*, 3: 259–285.
- . (1910a [1909]). Five lectures on psycho-analysis. *SE*, 11: 7–55.
- . (1912–1913a). Totem and taboo. *SE*, 13: 1–161.
- . (1930a [1929]). Civilization and its discontents. *SE*, 21: 57–145.
- . (1939a). Moses and monotheism: Three essays. *SE*, 23: 1–137.
- Freud, Sigmund, and Breuer, Josef. (1895a). Studies on hysteria. *SE*, 2: 48–106.
- Guyomard, Patrick. (1992). *La jouissance du tragique: Antigone, Lacan et le désir de l’analyste*. Paris: Aubier.
- Lacan, Jacques. (1997). *The seminar of Jacques Lacan. Book 7: The ethics of psychoanalysis (1959–1960)* (Dennis Porter, Trans.). New York: W. W. Norton. (Original work published 1986)
- Stein, Conrad. (1995). La traversée du tragique en psychanalyse. *Études freudiennes*, 35, 33–48.

---

## ETHNOPSICHOANALYSIS

Ethnopsychanalysis is a form of psychotherapy that makes use of two complementary fields of knowledge: psychoanalysis and anthropology. Early in his career

Sigmund Freud was careful to test the cultural diversity of his principal psychoanalytic concepts. The Oedipus complex, shortly after its introduction, was at the heart of the controversy between universalism and culturalism, and even today the question remains unresolved. Bronislaw Malinowski (1927) was one of the first anthropologists to take an interest in the relation between the psyche and culture through an analysis of the Oedipus complex among the Trobriand islanders, a matrilineal society. After Malinowski, the question was investigated by Géza Roheim and especially Georges Devereux (1970/1980, 1972), who further refined the relation between psychoanalysis and anthropology. Devereux postulated two fundamentals: psychic universality, toward which every human being tends, and cultural encoding, which is the effect of a culture on the content of the mind. Devereux held that researchers should focus on particulars without speculating about an abstract universal, which cannot be known a priori but was frequently inferred.

Ethnopsychanalysis is based on the methodological principle of complementarity, which “does not exclude any method, any valid theory, but coordinates them” (Devereux, 1972). It is pointless to forcibly and exclusively integrate certain human phenomena into the field of psychoanalysis or anthropology. Human phenomena, Devereux asserted, are so specific that they require a two-pronged multidisciplinary approach that can neither be fused together nor carried out simultaneously.

In France and the United States, Devereux developed a theory of ethnopsychanalysis based on the methodological principle of complementarity. Later in France, Tobie Nathan (1986) provided practical methods for its application, methods that are still being developed. Some parameters, however, appear to be well established (Moro, 1998): the need for a group of therapists in some cases, the importance of the patient’s native tongue and the need to make a transition to the patient’s language, the need to start from the patient’s cultural representations, the need to construct intermediate spaces halfway between culture and psyche that enable the individual to speak more freely and creatively, the need to modify of the duration of sessions (longer sessions designed to comply with the cultural temporality of the patient), and so on. Finally, to encourage discussion, Western therapists must learn to look beyond the Western worldview and to modify their system of reference.

In this context it is important to implement, in addition to the mechanics for analyzing transference and affective countertransference, a specific method for analyzing the therapist’s “cultural countertransference.” In concrete terms, at the end of each interview, the group of therapists should attempt to elucidate the countertransference of each therapist by discussing the affects they have experienced, implicit elements, and theories that led them to believe certain things (inferences), and by planning activities (interventions) at the individual and cultural levels.

Ethnopsychanalysis, which integrates the mental and cultural dimension of human dysfunctionality, is not a specific method, strictly speaking. Rather, it involves creating a complex cross-cultural psychotherapeutic setting that allows therapists to step outside of their own cultures and recognize the cultural differences of emigrant patients.

MARIE-ROSE MORO

*See also:* Anthropology and psychoanalysis; Balint-Szé-kely-Kóvacs, Alice; *Basic Problems of Ethnopsychiatry*; “Claims to Scientific Interest”; Devereux, Georges Incest; Individual; Individuation; Malinowski, Bronislaw Kaspar; Mead, Margaret; Morgenthaler, Fritz; Myth of origins; Róheim, Géza; Transcultural.

### **Bibliography**

- Devereux, Georges. (1972). *Ethnopsychanalyse complémentaire*. Paris: Flammarion, 1985.
- . (1980). *Basic problems of ethnopsychiatry* (Basia Miller Gulati, and George Devereux, Trans.). Chicago: University of Chicago Press. (Original work published 1970)
- Malinowski, Bronislaw. (1927). *Sex and repression in savage society*. New York: Harcourt, Brace.
- Moro, Marie-Rose. (1998). *Psychothérapie transculturelle des enfants de migrants*. Paris: Dunod.
- Nathan, Tobie. (1986). *La folie des autres: traité d’ethnopsychiatrie clinique*. Paris: Dunod.

---

## **ETHOLOGY AND PSYCHOANALYSIS**

Ethology is a biology of behavior. It has developed a nomenclature for describing the behavior of all living things in their natural environment using an approach that is naturalistic, experimental, and comparative. It

describes the structure of a behavioral sequence, its immediate causes, its adaptive benefits (its function), and its origin in the evolutionary development of the species and the biological development of the individual. Ethology has established itself as an observational method in some of the existing social sciences, including genetics, ethoecology, ethoneurology, ethosociology, etholinguistics, and ethopsychanalysis.

After World War II, René Spitz, faced with the behavioral pathology of abandoned children, following the work of Anna Freud, studied the genesis of object-relationships and the construction of the ego within a Freudian perspective. Strongly influenced by Konrad Lorenz and the then-new theory of cybernetics, he observed and manipulated the “eyes-nose-mouth” stimulus signal that triggers the suckling’s motor smile. He subsequently developed the concept of ego organizers and showed how the child’s mastery of the headshake, meaning “No,” marks the behavioral emergence of the process of symbolization.

In 1958, John Bowlby, then president of the British Psycho-Analytic Society, described the effects of a lack of maternal care. These findings showed an “astonishing convergence” (Zazzo, 1974) with the Harlows’ experiments on Rhesus monkeys, which demonstrated that the affective relationship between a mother and her infant was built not on nutritional needs but rather on a primary need for sensory exchange.

At the Twenty-First International Congress of Psychoanalysis in Copenhagen (1959), a stimulating debate was initiated. Some psychoanalysts felt that experiments on imprinting, epigenesis, stimulus-signals, synaptic facilitation, and the behavioral ontogenesis that constructs human ties buttressed the Freudian concept of drives. Others, however, felt that these ran counter to Freudian theory, since the idea of attachment as a primary bond contradicted that of an anaclitic relationship to drives. They also felt that direct observation added nothing to clear pictures of subject’s mental world that could be obtained from a historical approach.

In contemporary ethnopsychanalysis, the ethological method is used to observe the structuring of the primary bond and to evaluate it in terms of life events and cultural pressures with, as a base-line, the observation of the “strange situation” (Ainsworth et al., 1978).

The three levels of interaction distinguish the body, the affect, and the fantasy (Lebovici, 1991), which, as “psychic representative of the drive” (Freud), enables

the unconscious to give shape to the drive and thereby fashion the words and gestures (Cosnier, 1984) that act on the other. Interestingly, Jacques Lacan invoked ethology as early as 1936. His study of such phenomena as animal behavior in front of a mirror and the “dance” of sticklebacks enabled him to develop the fundamental concepts of the mirror stage and the interaction of the Real and the Imaginary in humans.

The psychoanalytic development an ethological anthropology allows us to situate man in the living world by emphasizing how the emergence of symbols and signs has created a specifically human, historicized world.

BORIS CYRULNIK

See also: Clinging instinct; Imaginary; Instinct; Primary need.

### Bibliography

- Ainsworth, Mary D. Salter, Blehar, M. C., Waters, E., and Wall, S. (1978). *Patterns of attachment: A psychological study of the strange situation*. Hillsdale, N.J.: Lawrence Erlbaum.
- Bowlby, John. (1958). The nature of the child’s tie to his mother. *International Journal of Psycho-Analysis*, 39, 350–373.
- Cosnier, Jacques. (1984). La psychanalyse, le langage et la communication. *Psychothérapies*, 4 (4), 215–222
- Harlow, Harry. (1958). La nature de l’amour. *Le psychologue américain*, 13, 673–685.
- Lebovici, Serge. (1991). La dépendance du nouveau-né. In Catherine Dechamp–Le Roux (Ed.), *Figures de la dépendance, autour d’Albert Memmi* (pp. 29–39). Paris: Presses Universitaires de France.
- Spitz, René A. (1957). *No and yes: On the genesis of human communication*. New York: International Universities Press.

---

## ÉTUDES FREUDIENNES

*Études Freudiennes* is a journal launched in 1969 by Conrad Stein, with Lucio Covello as recording secretary and Julien Bigras as Canadian correspondent (Stein was the French correspondent for the Canadian journal *Interprétation*). Its birth resulted from a schism in the editorial board of *L’inconscient*, on which Stein was a key figure, along with Piera Aulagnier–Spairani (editor in chief) and Jean Clavreul. According to their

last editorial (no. 8, October 1968), “The editors have not been able to agree about the orientation appropriate for a review of psychoanalysis, nor on the part they would like it to play.”

The first issue of *Études Freudiennes*, “Du côté du psychanalyste” (with the psychoanalyst), came out in November 1969. The first issue of *Topique*, “La formation du psychanalyste” (training the analyst), came out at the same time, with an announcement by Piera Aulagnier of the creation of a new psychoanalytic association: the Quatrième groupe, Organisation psychanalytique de langue française (Fourth Group, Francophone Psychoanalytic Organization).

Stein’s orientation is apparent in his short introduction to “Le patient inconnu” (The unknown patient) by Theodor Reik. He presents this text as being about “a kind of truth, unconnected with any school, about psychoanalysis.” This sums up what became the spirit of the journal.

*Études Freudiennes* is open to all tendencies in Freudian psychoanalysis, as long as authors show a serious commitment to psychoanalysis, are creative, and write well. It takes up questions relating to the training of psychoanalysts, their course of studies, and their supervision (nos. 1–2 and 31). Other areas of focus are the history of ideas (Sigmund Freud, Sándor Ferenczi, Jacques Lacan), the history of concepts (interpretation, femininity, transference love), and the practice of psychoanalysis in relation to its principles and the exigencies inherent in Freudian methodology.

From May 1982 (nos. 19–20) to September 1987 (no. 29), each issue gave rise to “study days,” when articles were discussed in the presence of their authors. Another special feature of *Études Freudiennes* has been the ongoing scientific debates, parallel to the published essays, in which experienced psychoanalysts associated with the review since its beginnings have encounters with younger colleagues invited to expound their points of view independently of ties to any organization and without fear of censure. This feature has added to its reputation in France and abroad, where some numbers have been translated (Italy, Germany, Brazil).

With a history of more than thirty years, *Études Freudiennes* has encountered its share of obstacles. Yet its flexibility in matters relating to the mind has helped it to overcome them.

DANIÈLE BRUN

See also: France.

### Bibliography

- Bataille, Laurence. (1985). D’une pratique. *Études Freudiennes*, 25, 7–30.
- Bauchau, Henry. (1984). La connivence des temps. *Études Freudiennes*, 23, 9–20.
- Perrier, François. (1994). Thanatol. In his *La chaussée d’Antin* (pp. 537–568). Paris: Albin Michel. (Originally published 1974)
- Reik, Theodor. (1969). Le patient inconnu. *Études Freudiennes*, 1–2, 7–38.
- Stein, Conrad. (1994). La traversée du tragique en psychanalyse. *Études Freudiennes*, 35, 33–48.
- Trilling, Jacques. (1973). James Joyce ou l’écriture matricide. *Études Freudiennes*, 7–8, 7–70.

---

## EUROPEAN PSYCHOANALYTICAL FEDERATION

The European Psychoanalytical Federation (EPF) is a scientific organization that consolidates all the European psychoanalytic societies affiliated with the International Psychoanalytic Association. In 2002 there were approximately 3,900 individual members in twenty-two countries, speaking eighteen different languages. It comprises twenty-five societies and three study groups (the Romanian Group, Belgrade Group, and Polish Group). A study group is the first level of integration of a psychoanalytic body within the International Psychoanalytic Association (IPA), followed by a provisional society and finally a member society.

The EPF was founded in 1966 by Raymond de Saussure, a well-known member of the Société suisse de psychanalyse (Swiss Society for Psychoanalysis), with Evelyne Kestemberg as secretary. The idea of a European psychoanalytic organization was first discussed at a series of European conferences on training, which had been organized every two years from 1960. The need for guidelines for psychoanalytic training in Europe contributed greatly to the creation of a European organization similar to the American Psychoanalytic Association, which had a unified training policy.

However, the European societies, concerned about their autonomy and independence in training matters, refused to accept this initial proposal and preferred the

model of a federation of independent societies. The EPF is administered by an executive board, composed of an executive committee of seven members (president, president-elect, two vice presidents, secretary, treasurer, newsletter editor) and the presidents of the member societies and study groups.

The EPF has always served as a clearinghouse and forum for psychoanalytic societies in Europe. In this sense its function is essentially scientific, unlike the International Psychoanalytic Association, which also serves as a political entity in that it establishes common standards for training and practice for all member psychoanalysts.

In its bylaws, the EPF has set forth six major goals: to promote the development of psychoanalysis; to maintain and improve the standards for practice, training, and teaching; to promote psychoanalytic research and distribute information about the theory and practice of psychoanalysis; to improve communication among psychoanalysts by means of various publications, newsletters, scientific conferences, and other meetings; to create a discussion space for scientific fields related to psychoanalysis and other subjects of concern to psychoanalysts; to promote contacts between psychoanalysis and other disciplines.

Although initially the EPF limited itself to organizing an annual conference on training and to publishing an annual twenty-page bulletin, in 2004 it organized more than ten annual or biannual scientific gatherings: colloquia and conferences on training and on child and adolescent analysis, a large conference open to all members and candidates, a clinical seminar for members, a scientific symposium on a controversial theoretical issue, a seminar and summer university in Eastern Europe for Eastern Europeans, a clinical seminar for Europeans and North Americans. As of 2004, was the *Bulletin de la Fédération européenne de psychanalyse* (120 pages) is now (in 2004) published semiannually in the three official languages of the EPF (German, English, and French) and includes papers presented at the various conferences held throughout Europe. These papers reflect contemporary psychoanalytic dialogue and the problems encountered in the various European psychoanalytic societies.

At the beginning of the twenty-first century the EPF is at a point where it will have to define its role inside and outside the world of analysis. European psychoanalytic societies need to address a range of issues, including the professional status of the psychoanalyst

(psychoanalyst or psychotherapist), the development of psychoanalysis in Eastern Europe, evaluation of the various methods of training, the difficulties associated with the many languages in Europe and the EPF's relation to diverse cultures and psychoanalytic traditions, and finally, the role of the EPF in light of the restructuring of the International Psychoanalytic Association, which, as an association of individual members, is evolving toward more adequate representation of the societies themselves. By providing a forum for discussing these issues, the EPF has agreed to promote a European psychoanalytic identity that allows for differences among European psychoanalysts while enabling them to focus on a limited number of scientific, ethical, and democratic values that reflect the Freudian tradition.

ALAIN GIBEAULT

### **Bibliography**

- Diatkine, Gilbert, and Gibeault, Alain. (1996). Le statut du psychothérapeute et/ou du psychanalyste. *Bulletin de la Fédération européenne de psychanalyse*, 46, 119–141.
- Gibeault, Alain. (1996). Réalité psychique et réalité externe dans le processus psychanalytique: 3e Conférence de la FEP sur l'analyse d'enfant et d'adolescent, Amsterdam, 1996. *Bulletin de la Fédération européenne de psychanalyse*, 47, 65–70.
- . (1997). La Fédération européenne a trente ans: Passé, présent, avenir. *Psychanalyse en Europe*, 49.
- Groen-Prakken, Han. (1986). Une organisation psychanalytique européenne: Le quand, le comment et le pourquoi: un aperçu historique de la fondation et du développement de la F.E.P. *Psychanalyse en Europe*, 26–27, 11–65.
- . (1997). Vers une Fédération européenne de psychanalyse: Le développement du mouvement psychanalytique en Europe centrale et de l'Est, 1987–1996. *Psychanalyse en Europe*, 48 (1), 5–25.

---

## **EVENLY-SUSPENDED ATTENTION**

Evenly-suspended attention describes the necessary state of the analyst's mind when listening to the patient during a psychoanalytic session. It is the mirror image of the method of free association required of the patient.

Freud set forth the notion of free-floating attention in *The Interpretation of Dreams* (1900a) in connection with the secondary revision of the dream and the atti-

tude the interpreter must take: “For the purposes of *our* interpretation it remains an essential rule invariably to leave out of account the ostensible continuity of a dream as being of suspect origin, and to follow the same path back to the material of the dream-thoughts, no matter whether the dream itself is clear or confused” (p. 500).

His technical prescription is found in “Recommendations to Physicians Practising Psycho-Analysis” (1912e): “[I]t rejects the use of any special expedient (even that of taking notes). It consists simply in not directing one’s notice to anything in particular and in maintaining the same ‘evenly-suspended attention’ (as I have called it) in the face of all that one hears . . . . It will be seen that the rule of giving equal notice to everything is the necessary counterpart to the demand made on the patient that he should communicate everything that occurs to him without criticism or selection. If the doctor behaves otherwise, he is throwing away most of the advantage which results from the patient’s obeying the ‘fundamental rule of psychoanalysis.’ The rule for the doctor may be expressed: ‘He should withhold all conscious influences from his capacity to attend, and give himself over completely to his ‘unconscious memory.’ The doctor must put himself in a position to make use of everything he is told for the purposes of interpretation and of recognizing the concealed unconscious material without substituting a censorship of his own for the selection that the patient has forgone” (pp. 111–12). The psychoanalyst must be able to interpret everything he hears in order to discover everything that the unconscious disguises, and this without substituting his own censorship for the selectivity the patient has renounced.

In his 1923 encyclopedia article “Psycho-Analysis,” Freud returned to the topic: “Experience soon showed that the attitude which the analytic physician could most advantageously adopt was to surrender himself to his own unconscious mental activity, in a state of evenly suspended attention, to avoid so far as possible reflection and the construction of conscious expectations, not to try to fix anything that he heard particularly in his memory, and by these means to catch the drift of the patient’s unconscious with his own unconscious” (p. 239). Two years later, in a letter to Ludwig Binswanger dated February 22, 1925, he tempered the somewhat excessive aspect of this description: “In a more systematic formulation, unconscious must be replaced with preconscious” (2003, p. 179).

Some authors (notably James Strachey in the Standard Edition) have proposed as alternatives the terms *evenly-suspended* or *evenly-hovering attention* (in French, both *attention également flottante* and *attention flottante* are used). This prescribed attitude for the analyst has been considered one of the constitutive elements of the analytic setting. Associated with “neutrality,” it has also been compared with Theodor Reik’s notion of “listening with the third ear.” Since it requires that the analyst suspend judgment and eliminate his or her internal resistances and all personal censorship, it is clear that only prior analysis of the analyst can ensure that this state is maintained. In this special state, identifications and projections must be able to float freely, but some authors have emphasized the risk of falling asleep if the analyst is too intent on conforming to it (Fenichel, 1941). This observation has incited other authors to see in free-floating attention a state of self-hypnosis parallel to that triggered in the patient by the analytic setting (François Roustang).

Contrary to the passivity and static aspect suggested by this description, Joseph Sandler has argued that the dynamic back-and-forth between this state and the return to a countertransference analysis of what is perceived are conducive to “free-floating responsiveness” in the analyst (Sandler 1976, 1993).

ALAIN DE MIJOLLA

*See also:* Framework of the psychoanalytic treatment; Free association; Fundamental rule; Psychoanalytic treatment; “Recommendations to Physicians Practising Psycho-Analysis.”

### **Bibliography**

- Freud, Sigmund, and Binswanger, Ludwig. (2003). *The Sigmund Freud-Ludwig Binswanger correspondence 1908–1938*. (Arnold Pomerans, Trans.). New York: The Other Press.
- Fenichel, Otto. (1941) *Problems of psychoanalytic technique*. (David Brunswick, Trans.). New York: The Psychoanalytic Quarterly.
- Ornstein, Paul H. (1967). Selected problems in learning how to analyze. *International Journal of Psycho-Analysis* 48, 448.
- Sandler, Joseph. (1976). Counter-transference and role-responsiveness. *International Review of Psycho-Analysis* 3, 43–47.

———. (1993). On communication from patient to analyst: not everything is projective identification. *International Journal of Psycho-Analysis*, 74, 1097–1108.

## ÉVOLUTION PSYCHIATRIQUE (L'-) (DEVELOPMENTS IN PSYCHIATRY)

Before becoming the title of the review first published in 1929, with chief editors Henri Codet and Eugène Minkowski contributing to the first issues, *L'Évolution psychiatrique* was already the title of a collective work in two volumes (1925 and 1927), directed by Angélo Hesnard and René Laforgue.

In 1930 a study group was formed around the nucleus of collaborators in the review. This group contained no fewer than seven of the founding members of the Paris Psychoanalytic Society in 1926, but it did not seek to institutionalize psychoanalysis. Psychiatry was constantly evolving thanks to new acquisitions, including psychoanalysis which, although it appeared to be the most innovative, was not the only one, and the members of the group wanted their discipline, which was still stuck in declining alienism, to evolve. The philosophical ideas of the time would also contribute to this movement.

The name chosen was an obvious indication of the influence of Henri Bergson and his *Évolution Créatrice* (Creative evolution; 1907). *L'Évolution psychiatrique* (EP) would present the work of Eugène Minkowski, who published the first French-language volume of phenomenological psychopathology, *Le Temps vécu* (Time lived; 1934), and also Ludwig Binswanger, Karl Jaspers, and Viktor von Gebsattel. In 1934, Henri Ey used the review to present Eugen Bleuler's ideas on the group of schizophrenic psychoses (1911), an application of the nascent psychoanalysis to Emil Kraepelin's *dementia praecox*. Jacques Lacan's thesis, *De la psychose paranoïaque dans ses rapports avec la personnalité* (Paranoid psychosis and its relations to the personality; 1932) is another example of this psychoanalytic rereading of Kraepelin's entities that was to renew psychiatry. After the war, the exchanges between Ey and Lacan were milestones in the life of the society, which had interrupted its activity during the German occupation of France and suspended the publication of the review between 1940 and 1947. On the occasion of the *Journées de Bonneval*, Ey brought

together psychiatrists, psychoanalysts, and philosophers, and their debates on the psychogenesis of neuroses and psychoses (1946), schizophrenia (1958), and lastly the unconscious (1960), would go down in history.

In 1950, *L'Évolution psychiatrique* organized the first World Congress on Psychiatry in Paris, the presence of Anna Freud and Melanie Klein testifying to the importance attached to psychoanalysis. And in 1956 the centenary of Freud's birth was marked by an issue devoted to his work.

In 1955, the publication, under the direction of Ey, of the *Traité de psychiatrie* (Treatise on Psychiatry) in the *Encyclopédie médico-chirurgicale* (Medical and surgical encyclopedia) written by one hundred and thirty-two authors, psychiatrists, and psychoanalysts and almost all of the members of *L'Évolution psychiatrique*, marked a major moment in the history of the society. The unity in diversity thus realized was shattered soon afterwards, when psychiatry was recognized as a medical specialty distinct from neurology. The distinction was influenced by various factors: schisms in Freudian France, progress in psychopharmacology, different "anti-psychiatry," the success of behaviorism and cognitivism, and the appearance of the "neurosciences." The Seventh World Congress on Psychiatry, held in Vienna in 1984, could have declared psychoanalysis dead. For a quarter of a century the astonishing increase in the number of psychiatrists in France caused a multiplication in the number of societies with one approach and made *L'Évolution psychiatrique* the only place where phenomenologists, structuralists, biologists, psychotherapists, cognitivists, and analysts from different schools could confront each other's views. It is therefore not surprising that when psychiatrists again felt the need to reflect together on recent progress in their discipline, *L'Évolution psychiatrique* played an essential role in the creation of the French Federation for Psychiatry (1992).

JEAN GARRABÉ

See also: France; Hesnard, Angélo Louis Marie; Laforgue, René.

### Bibliography

Ey, Henri. (1955). *Traité de psychiatrie clinique et thérapeutique*, Paris: E.M.-C.

## EXAMINATION DREAMS

In examination dreams, which Freud considered to be “typical dreams,” the dreamer sees himself back at school taking an examination.

Freud mentions this type of dream several times in *The Interpretation of Dreams* (1900a). The dreamer is embarrassed to see himself as an adult among much younger fellow students and obliged to retake an examination that he already passed a long time ago. “It would seem, then, that anxious examination dreams (which, as has been confirmed over and over again, appear when the dreamer has some responsible activity ahead of him next day and is afraid there may be a fiasco)” (1900a, p. 274). The meaning of the dream would be: “Don’t be afraid of tomorrow! Just think how anxious you were before your Matriculation, and yet nothing happened to you” (1900a, p. 274).

The interpretation can nevertheless prove to be more complex: In Chapter 6, Freud recounts one of his own dreams, an “absurd dream about a dead father” (1900a, p. 435), which is marked by uncertainty about the dates of his own birth and his father’s death. Freud analyzes the uneasiness about filiation and hostility to the father (who in this dream admits to having been arrested for drunkenness) by associating it with his memory of having been a slow medical student: “In my circle of acquaintances I was regarded as an idler and it was doubted whether I should ever get through” (1900a, p. 450). It is therefore about an oedipal issue (particularly from the point of view of rivalry with the father).

Freud never returned to examination dreams, and the theme seems to have received little attention outside of the United States. However, these dreams are encountered frequently in clinical practice.

ROGER PERRON

*See also:* Dream.

### Bibliography

Freud, Sigmund. (1900a). The interpretation of dreams. Parts I and II. *SE*, 4–5: 1–625.

### Further Reading

Kafka, Ernest. (1979). On examination dreams. *Psychoanalytic Quarterly*, 48, 426–447.

Ostow, Mortimer. (1995). The examination dream revisited: A clinical note. *Psychoanalytic Study of the Child*, 50, 418–424.

Renik, Owen. (1981). Typical examination dreams; superego dreams; traumatic dreams. *Psychoanalytic Quarterly*, 50, 159–189.

## EXCITATION

*Excitation* is a term borrowed from the lexicon of commonplace words derived from the Vulgar Latin *excitatio*: “the action of exciting”; it is used notably in physics and physiology. Sigmund Freud, and other psychoanalysts after him, expanded this term for use in metapsychology, particularly the economic dimensions of that approach. In this usage, the word carries with it the connotations of the Latin *excitare*: “to awaken, wake up, push, or stimulate at the level of the psychic apparatus.”

This psychic apparatus, the fictional representation of metapsychological topography, appears as the locus of reception, transformation, and capacity for adequate discharge of excitation. Even before his analytic period per se, Freud in “The Psycho-Neuroses of Defence” (1894a) envisaged the sum of excitation as a quantum of affect that is spread over the memory traces of representations. It is in this light that, for want of a connection with affect, he posits an “abreaction” caused by the excess of excitation. It is also necessary that endogenous excitations reach a certain threshold in order to become mental excitations. In *The Interpretation of Dreams* (1900a) he conjectures that “during certain psychical processes the systems may be traversed in a temporal sequence determined by excitation”

Excitation may be external in origin, in the form of a stimulus coming from the object or the environment, and the problem becomes the manner in which it is handled, bound, and evacuated. Here Freud advances the concept of the “protective shield” that serves to protect against an overflow of excitation, which he views as being traumatic. Envisioning trauma as a “breaking through of the protective shield” is one of the perspectives he offers. But overflow can also originate internally. In cases where sound psychic defensive systems are lacking—above all, a failure of defense through repression, which would prevent satisfaction and discharge toward the outside—the result is the mental symptom as a sign and



substitute for an instinctual satisfaction that has not taken place, like a foreign body that keeps producing phenomena of excitation and reaction in the (mental) tissue in which it is implanted.

Excitation is thus also included in the register of the pulsional system. Instinct, a borderline concept between the psychic and the somatic, is posited as an excitation for the psyche. It is found in connection with the terms *drive*, *aim*, and *source*.

- Drive: driving factor, the measure of the amount of impulse toward a particular action or end.
- Aim: a satisfaction that is only attainable through successfully suppressing the very cause of the initial excitation. Following Freud, we could say that the psychic apparatus serves the intention of mastering and eliminating quantities of excitation, whether this excitation arrives from without or within.
- Source: any somatic process in an organ or part of the body whose excitation is represented in mental life by the instincts. The raw material of psychic disturbances is posited as being inherent in this register of excitation of somatic origin; here we find the physiological notion of excitation. This excitation must undergo a process of mental work to enter into the pulsional system, or indeed must transform its quantum of energy into mental energy. If this transformation does not occur, somatic sexual excitation, for example, ostensibly remains in that form and does not turn into psychosexual excitation; this is the Freudian approach to the concept of “actual (or defense) neurosis,” advanced relatively early on. This approach requires levels of discharge rather than repression as the constituents of its symptoms.

Beyond a certain threshold of excitation, Freud evokes the notion of “libidinal coexcitation,” which ostensibly disappears over time; this is supposedly the point from which fixation begins. Thus the instincts, in contrast to stimulus or external excitation, never act as a force of momentary impact, but rather as an ongoing force. Thus too, the final goal of mental activity—the tendency to obtain pleasure and to avoid unpleasure—can be envisioned, in economic terms, as an effort to master the masses of excitation that reside in the psychic apparatus.

The concept of conversion brings with it the enigma of the leap from mental excitation to the somatic

level—the true “vicissitude” of the instincts, a process that is above all discernible in the structures of hysteria. Jean-Paul Valabrega takes up this notion of discharge through conversion in approaching psychosomatic phenomena, while other authors invoke the idea of a return of excitation to its earliest source, the somatic level, in the absence of successful mentalization. In the view of Pierre Marty, the flow of the excitations from the instincts and the drives, essentially aggressive and erotic, constitutes the central problem in somatization. He contends that in the absence of sound regulation by the psychic apparatus and thus of the possibility for adaptation, the excess or deficit of excitation causes a trauma that can become the point of departure for the process of somatization.

Finally, following the introduction of the death instinct in *Beyond the Pleasure Principle* (1920g), Freud somewhat reconsiders excitation within the framework of the life and death instincts. The force and the flow (or retention) of excitation are reexamined, in light of the principles of constancy and inertia that he had already developed but further elaborates here. It should be recalled that, for Freud, although the animistic process is automatically regulated by the pleasure-unpleasure principle, the economic viewpoint accepts that the mental representatives of the instincts are invested with determined quantities of energy and that the psychic apparatus tends to maintain at the lowest possible level the sum total of excitations it carries. But the very essence of instinctual functioning is also envisioned: the tendency toward inertia under the influence of the death instinct. Repetition compulsion (the instinct’s instinct, according to Francis Pasche) is arguably a way to deal with the surplus of excitation that is not bound to the instinct as the result of post-traumatic defusion. Freud’s example of the repetition of traumatic dreams provides an illustration of this. In this view, the aim of repetition compulsion is the extinction of traumatic excitation through exhaustion—and this to the point of inertia, the aim of the death instinct.

This posited aim enables Freud to propose a notion drawn from the philosophy of the Far East: the nirvana principle, whose aim is total discharge—a quasi-metaphysical and existential approach that transcends the metapsychological economic register. This principle takes to its extremes and goes beyond another of Freud’s principles, the principle of constancy.

ALAIN FINE

*See also:* Anxiety; Conversion; Discharge; Erotogenic masochism; Erotogenic zone; Facilitation; Helplessness; Pain; Psychic envelopes; Libido; Mania; Mastery; Skin-ego; Nirvana; Object; Pleasure/unpleasure principle; Principle of constancy; Primal repression; Protective shield; Protective shield, breaking through the; Quantitative/qualitative; Quota of affect; Reciprocal paths of influence (libidinal coexcitation); Regression; Sleep/wakefulness; Sum of excitation; Trauma; Wish, hallucinatory satisfaction of a.

### **Bibliography**

- Freud, Sigmund. (1894a). The psycho-neuroses of defence. *SE*, 3: 45–61.
- . (1900a). The interpretation of dreams. Part I, *SE*, 4: 1–338; Part II, *SE*, 5: 339–625.
- . (1915c). Instincts and their vicissitudes. *SE*, 14: 117–140.
- . (1920g). Beyond the pleasure principle. *SE*, 18: 7–64.

## **EXHIBITIONISM**

“Exhibitionism” commonly denotes a sexual perversion in which satisfaction is linked to the displaying of one’s genital parts. Psychoanalysis broadens this notion by acknowledging many early manifestations of this tendency in the sexual life of the child. Freud showed how infantile sexuality, prior to the establishment of the genital functions, was governed by the interplay of various component instincts which manifest themselves most often as pairs of opposites and each of which is linked to a particular erotogenic zone. In this context exhibitionism is one of the elements of instinctual life, making its appearance in conjunction with its opposite, namely pleasure in looking, both being related to the eye as the relevant erotogenic zone. Seen in this light, exhibitionism as a perversion in the adult bespeaks regression to an earlier fixation of the libido.

It was chiefly in his *Three Essays on the Theory of Sexuality*, including the notes added to this work over its successive editions, that Freud outlined his conception of exhibitionism: “exhibitionists, . . . if I may trust the findings of several analyses, exhibit their own genitals in order to obtain a reciprocal view of the genitals of the other person.” A note added in 1920 elaborates: “Under analysis, these perversions . . . reveal a surprising variety of motives and determinants. The compulsion to exhibit, for instance, is also closely dependent

on the castration complex; it is a means of constantly insisting upon the integrity of the subject’s own (male) genitals and it reiterates his infantile satisfaction at the absence of a penis in those of women” (p. 157 and n.). The anxiety aroused by the perception of this real lack of the penis in women—in the mother, for example—led Freud to describe how, by the mechanism of disavowal, such a perception could be so thoroughly denied that an object, a fetish, could come to stand for the absent penis and “become the chosen object determining the achievement of sexual pleasure” (Green, 1990). For Guy Rosolato (1967), “fetishism is at the heart of all perversion in that it disavows the difference between the sexes”; it must therefore, and a fortiori, be central to exhibitionism.

Let us note, lastly, that exhibitionism as a manifestation of childhood sexuality is a common phenomenon and a part of sexual play. The desire to show off the genitals is linked to the needs for reassurance and knowledge. Child psychologists underline the importance of such play, though they insist that it should be confined to children of the same age, generally within a group where the curiosity is shared.

DELPHINE SCHILTON

*See also:* “Instincts and Their Vicissitudes”; Perversion; Scopophilia/scopophilia; *Three Essays on the Theory of Sexuality*; Turning around; Turning around upon the subject’s own self.

### **Bibliography**

- Freud, Sigmund. (1905d). Three essays on the theory of sexuality. *SE*, 7: 123–243.
- Green, André. (1990). *Le Complexe de castration*. Paris: Presses Universitaires de France.
- Lebovici, Serge, Diatkine, René, and Soulé, Michel. (1985). *Traité de psychiatrie de l’enfant et de l’adolescent*. Paris: Presses Universitaires de France.
- Rosolato, Guy. (1967). Étude des perversions sexuelles à partir du fétichisme. In Piera Aulagnier-Spairani, et al., *Le désir et la perversion* (pp. 9–52). Paris: Seuil.

## **EXPERIENCE OF SATISFACTION**

In *The Language of Psychoanalysis*, Jean Laplanche and Jean-Bertrand Pontalis gave the following definition of “experience of satisfaction”: “Type of primal experience postulated by Freud, consisting in the resolution,

thanks to an external intervention, of an internal tension occasioned in the suckling by need. The image of the satisfying object subsequently takes on a special value in the construction of the subject's desire. This image may be recatheted in the absence of the real object (hallucinatory satisfaction of the wish). And it will always guide the later search for the satisfying object" (1967/1973, p. 156).

The concept of the experience of satisfaction—real or hallucinatory—is obviously a cornerstone in Sigmund Freud's metapsychological construction in that it raises the issue of the mnemonic registration of the encounter with the object and in that it tries to articulate the problematic of the assuagement of need and the fulfillment of desire. Freud evoked the experience of satisfaction as early as the "Project for a Scientific Psychology" (1950c [1895]): "The residues of the two kinds of experiences [of pain and of satisfaction] which we have been discussing are affects and wishful states are affects and wishful states. These have in common the fact that they both involve a raising of Q<sub>é</sub> tension in  $\Psi$ —brought about in the case of an *affect* by sudden release and in that of a *wish* by summation" (pp. 321–322).

Freud also referred to this concept several times in *The Interpretation of Dreams* (1900a), after which it faded somewhat before reappearing in "Formulations on the Two Principles of Mental Functioning" (1911b): "It was only the non-occurrence of the expected satisfaction, and the disappointment experienced, that led to the abandonment of this attempt at satisfaction by means of hallucination. Instead of it, the psychological apparatus had to decide to form a conception of the real circumstances in the external world and to endeavour to make a real alteration in them. A new principle of mental functioning was thus introduced" (p. 219).

He returned to the concept yet again in "Negation" (1925h) in an attempt to link together the experience of satisfaction, on the one hand, and the reality principle, on the other: "[I]t is evident that a precondition for the setting up of reality testing is that objects shall have been lost that once brought real satisfaction" (p. 238). In other words, not only does the experience of satisfaction serve as a bridge between need and desire, it is also the basis for reality testing, which is set in motion by the absence of the real object and by insufficient compensation for that absence through the reactivation of memory traces.

The discussion of the experience of satisfaction thus raises the whole question of primitive hallucination, which Freud, as we know, deemed crucial to the emergence of the infant's very first mental representations. Initially, the experience of satisfaction is linked to the baby's fundamental immaturity—that is, its state of helplessness, its primary and fundamental powerlessness (*Hilflosigkeit*). Incapable on its own of affecting the tension produced by endogenous excitations, the infant must rely on intervention by an outside person. (Guy Rosolato would later interpret this as being the germ of the differentiation between the realm of need and that of sexual difference and autoerotism.) Satisfaction thus comes to be associated with the image of the outside object that has relieved tensions, and when these reappear, there is an active recathexis of the image of the object. Should this recathexis be overly intense, it is liable to produce the same "indication of reality" as the perception itself (hence the possible confusion between the real and hallucinated object, a confusion that is at the heart of the dynamics of desire). According to Laplanche and Pontalis, "the wish, though it originates with a search for actual satisfaction, is constituted on the model of the primitive hallucination" (p. 156). The formation of the ego is what puts an end to this confusion between hallucination and perception by means of its inhibiting role, which prevents an overly intense recathexis of the image of the satisfying object.

Involved here are the notions of "thought identity" and "perceptual identity," which Freud introduced as early as *The Interpretation of Dreams*: what the subject seeks through the direct path of hallucination (thought identity) is invariably something identical to the perception formerly associated with the satisfaction of a need (perceptual identity).

Recent work has attempted to distinguish between the experience of satisfaction and the experience of instinctual gratification, conceived as being broader. In reality, the main discussions have focused more on the nature of primitive hallucination than on the experience of satisfaction itself. Or rather, what is debated is the place of primitive hallucination in the process of the emergence of thought. Some authors have continued to place the absence of the object at the center of this process, while others have emphasized the presence of the object and its relationship with the subject or future subject. Clearly, the experi-

ence of satisfaction is what links these two approaches, the first of which is characteristic of classical psychoanalysts and the second of so-called developmental psychoanalysts, who in particular want to introduce attachment theory into their thinking (John Bowlby).

The absence and presence of the object appear in fact to be fundamentally inseparable, and it is undoubtedly in the experience of satisfaction that the dynamic interactions of need and desire, and even of demand, are most tightly enmeshed.

BERNARD GOLSE

*See also:* Infantile omnipotence; Pain; Pleasure/unpleasure principle; "Project for a Scientific Psychology"; Symbolization, process of; Wish, hallucinatory satisfaction of a.

### **Bibliography**

- Freud, Sigmund. (1900a). The interpretation of dreams. *SE*, 4–5: 1–635.
- . (1911b). Formulations on the two principles of mental functioning. *SE*, 12: 213–226.
- . (1925h). Negation. *SE*, 19: 233–239.
- . (1950c [1895]). Project for a scientific psychology. *SE*, 1: 281–287.
- Laplanche, Jean, and Pontalis, Jean-Bertrand. (1973). *The language of psycho-analysis* (Donald Nicholson-Smith, Trans.). New York: Norton. (Original work published 1967)
- Rosolato, Guy. (1964). La différence des sexes. *Essais sur le symbolique*. Paris: Gallimard, 1969.

---

## **EXTERNALIZATION-INTERNALIZATION**

The terms *externalization* and *internalization* refer to a specific psychic modality of externalizing and internalizing the object. In general, externalization and internalization do not bear on aspects of the object, but rather on the relationships and conflicts that are inherent in the object and that it maintains with other objects. Therefore, if a given aspect of the object is internalized or externalized, a relationship is internalized or externalized. In "Analysis Terminable and Interminable" (1937c), Freud noted that "the ego grows accustomed to removing the scene of the fight from outside to

within and to mastering the *internal* danger before it has become an *external* one" (p. 235). Freud was describing the ego's capacity for internalization, but was adopting a phylogenetic perspective: "[I]n the course of man's development from a primitive state to a civilized one his aggressiveness undergoes a very considerable degree of internalization or turning inwards; if so, his internal conflicts would certainly be the proper equivalent for the external struggles which have then ceased" (p. 244). His essential concern here was to argue for the dualism of instincts and to suggest that the death drive is equal in importance to Eros.

It was Anna Freud who introduced the clinical perspective in *Normality and Pathology in Childhood, Assessments of Development* (1965/1980). In evaluating pathology in terms of the type of anxiety and conflict experienced by the child, she distinguished internalized external conflicts, which correspond to anxieties linked to fear of object-loss and feelings of guilt, from conflict she described as "truly internal" (p. 133). The latter derives from the relationship between the id and the ego and their conflicting aims. According to her, only analysis can give access to this type of conflict.

DELPHINE SCHILTON

*See also:* Character neurosis; Group psychotherapies; Identification; Internal object; Word-presentation.

### **Bibliography**

- Freud, Anna. (1980). *Normality and pathology in childhood, assessments of development*. New York: International Universities Press. (Original work published 1965)
- Freud, Sigmund. (1937c). Analysis terminable and interminable. *SE*, 23: 209–53.

---

## **EXTROVERSION/INTROVERSION (ANALYTICAL PSYCHOLOGY)**

Extroversion and introversion are, for Carl Gustav Jung, two typical attitudes of the personality. These terms describe and distinguish two directions of energy within consciousness that attract the individual toward, on the one hand, the external world and its objects, and on the other hand, the internal world and its images. This typological distinction is to be understood as a function of the unconscious dynamics particular to each person. It is not intended to group

together specific and superficial traits of individuals in a characterological way.

The terms *extroversion* and *introversion* were first used in 1913 at the Fourth International Congress of Psychoanalysis in Munich, the occasion of the last meeting between Sigmund Freud and Jung and of their irrevocable rupture. At the time, the terms corresponded to personal concerns: At issue, for Jung, was understanding the conflicts dividing the psychoanalytic movement. This was the thrust of his lecture entitled “The Question of the Psychological Types,” which he concluded by opposing Alfred Adler’s theory, which he termed *introverted*, to Freud’s theory, supposedly *extroverted*, in that the one was centered around a subjective wish (for power), while the other was centered around a sexual quest (for the object). But, beyond this contrast, the importance that Jung attached to the typology illustrates one of his main intellectual choices: the relativization of all theories, including his own.

Extroversion and introversion coexisted in each person, according to Jung, but in different modes. In the normal subject, both were available to consciousness and came into play in alternation to meet the dual necessities of internal adaptation (the unconscious) and external adaptation (outer reality). Type—whether extroverted or introverted—was defined by the relative predominance of one or the other of the two attitudes in the realm of consciousness, the other attitude being partially relegated to the unconscious, where it acted in a compensatory unconscious mode. Finally, in pathological personalities, a single attitude predominated systematically and chronically; the opposing attitude was inaccessible to consciousness, and the compensatory role of the unconscious was manifested only in the form of symptoms.

Extroversion and introversion are in keeping with Jung’s conception of, and practical approach to, the unconscious and with Jungian practices. In this perspective, the unconscious is not solely pathogenic, but also has the potential to create balance, in particular through its compensatory role: it can bring into conscious awareness thoughts, tendencies, and impulses that consciousness neglects or rejects. Dreams, symbols, and parapraxes—also in addition to symptoms—serve as vectors of these unconscious compensations.

Extroversion and introversion cannot be conceived without four functions that are their modes of expres-

sion: thought, feeling, intuition, and sensation. It is important not to confuse a particular feeling, thought, sensation, or intuition with the function that mobilizes it. The former are contents of different values, while the latter is an operating system that makes it possible to utilize the corresponding content. Jung situates these four functions in systems of oppositions. He especially emphasizes the dynamic relation between the privileged function, which partakes of the power of consciousness, and the inferior function, which, by virtue of the fact that it is relegated to the unconscious, is less differentiated, but also contains a strong potential for change. The integration of this inferior function into consciousness is one of the paths to individuation.

Among criticisms of these Jungian views, the most vehement are directed less at the categories of extroversion and introversion than at the functions, their division into rational-irrational pairs, their number, and the nature of their opposition.

Admittedly, the typology of attitudes proposed by Jung and his theory of the functions could be further refined, but, far from having been conceived after the fashion of a personality test, they provide the stimulus for conceptualizing and dealing with the workings of the psyche as a system that is structurally complex, dynamic, and ever-evolving.

MARIE-LAURE GRIVET-SHILLITO

*See also:* Jung, Carl Gustav; Midlife crisis; Psychological types (analytical psychology).

### **Bibliography**

- Hillman, James. (1971). *The Feeling Function, in Lectures on Jung’s Typology*. Zürich: Spring.
- Jung, Carl Gustav. (1921). *Psychological Types. Collected Works*, 6. London: Routledge and Kegan Paul.
- Samuels, Andrew. (1985). *Jung and the Post-Jungians*. London and Boston: Routledge.
- Franz, Marie-Louise von. (1971). *The Inferior Function, in Lectures on Jung’s Typology*. Zürich: Spring.

---

## **EY, HENRI (1900–1977)**

Henri Ey, a French psychiatrist and philosopher, was born on August 10, 1900, and died on November 9, 1977, in Banyuls-dels-Aspres, in the Pyrénées-Orientales region of France. After completing his secondary educa-

tion in Sorèze, Ey began studying medicine in Toulouse. He was accepted as an intern at the Asiles de la Seine in 1925 and completed his studies in Paris, where he also studied philosophy at the Sorbonne and attended classes by Pierre Janet at the Collège de France. During this period he became friendly with several other interns, in particular, Jacques Lacan, Pierre Mâle, and Julien Rouart.

In 1931, while working at the Clinique des maladies mentales (Mental Health Clinic) at Sainte-Anne Hospital, Ey, a senior psychiatrist under Professor Henri Claude, met the first French psychoanalysts invited to practice there: René Laforgue, René Allendy, and Édouard Pichon. These men were among the founders of the Société psychanalytique de Paris (Paris Psychoanalytic Society). Together with Eugène Minkowski, they were among the first contributors to the journal *L'évolution psychiatrique* (Psychiatric evolution), launched in 1925 and published since then by the group of the same name that it gave birth to. The reference to *L'évolution créatrice* (Creative Evolution) by Henri Bergson, who critiqued Freud's first publications from a philosophical point of view, helps explain the genealogy of ideas. During the war and occupation *L'évolution psychiatrique* suspended activity, but afterward Ey succeeded Minkowski as manager and editor-in-chief of the journal.

Ey spent most of his career working in hospitals. In 1931 he was appointed as doctor of psychiatry, his first and only position, at Bonneval Psychiatric Hospital (today the Henri Ey Hospital), where he remained until his retirement in 1970. The only interruption occurred when he was mobilized as an army doctor during the war, from 1939 to 1940, and at liberation.

Ey's theoretical work was devoted to applying to the study of mental disorders the ideas of the English neurologist Hughlings Jackson, who was himself inspired by the organicism of the philosopher Herbert Spencer (1820–1903). In organicism (not to be confused with "organicism" in the medical sense), psychic life is characterized by its hierarchical organization, the development of individual functions, their ontogenesis (which reflects the order of their appearance among the species), and phylogenesis. This approach influenced the neurological work of Sigmund Freud, whose *On Aphasia: A Critical Study* (1953) is nothing more than the application of Jackson's principles to aphasia. In 1938 Ey published, together with Julien Rouart, the *Essai d'application des principes de Jackson à une conception dynamique de la*

*neuropsychiatrie* (The application of Jackson's principles to a dynamic conception of neuropsychiatry), though Rouart distanced himself from the ideas expressed in the monograph when it was reissued in 1975.

One of Ey's last psychoanalytic essays to appear before the four years of silence that ensued under the occupation was his "Réflexions sur la valeur scientifique et morale de la psychanalyse" (Reflections on the scientific and moral value of psychoanalysis; 1939). The essay was a response to ideas that Roland Dalbiez had expressed in 1936 in *La méthode psychanalytique et la doctrine freudienne* (Psychoanalytic method and Freudian theory). Ey's article was a brilliant measured attack against psychoanalysis as it existed in France, and the conclusion provides a clear overview of a position he never wavered from: "By attempting to reduce psychoanalysis to its exact limits and by showing that it operates within a zone of indeterminacy greater than Mr. Dalbiez appears to be aware of, we have attempted to be somewhat more relaxed in our criticism of the ideology that has crystallized around a major discovery—Freud's exploration of the unconscious." Throughout his life Ey expressed the same reservations, but these reservations did not prevent him from organizing meetings and discussions that were among the most exhilarating in the history of psychoanalysis in France.

Ey organized a number of famous conferences at Bonneval. Two of the best known are the third, "Le problème de la psychogenèse des névroses et des psychoses" (The problem of the psychogenesis of neuroses and psychoses; 1946), with contributions from Jacques Lacan, who discussed the organodynamism of his friend Julien Rouart, and the sixth, "L'inconscient" (The unconscious; 1960), the text of which was published in 1966 after considerable revision.

Ey had little doubt that psychoanalysis was part of the medical science of psychiatry. It was with this in mind that he organized the first Congrès mondial de psychiatrie (World Congress of Psychiatry), which was chaired by Jean Delay in Paris in 1950. The participants included several of leading names in psychoanalysis at the time: Franz G. Alexander, Anna Freud, Melanie Klein, Jacques Lacan. The congress was so successful that the organizing association transformed itself into the World Psychiatric Association, whose first executive secretary, until 1966, was Ey.

In 1955 Ey edited the first edition of the *Traité de psychiatrie* (Treatise on psychiatry) in the *Encyclopédie*

*médico-chirurgicale* (Medical-surgical encyclopedia). He assigned several chapters to some of the best known analysts of the time, especially those working on neuroses and psychoanalytic theory and practice. Jacques Lacan wrote the chapter “Variantes de la cure-type” (Treatment alternatives).

In 1960 Ey published, with Paul Bernard and Charles Brisset, the *Manuel de psychiatrie* (Manual of psychiatry), which went through six French editions and numerous translations. The manual introduced medical doctors to an approach to psychiatry that transcended the mechanical, linear model that arose out of medical organicism at the end of the nineteenth century. Ey strongly opposed abandoning the ethical dimension of medicine in the treatment of mental patients, which, in his view, was happening in the antipsychiatric movement and could be found as well in the misuse of psychiatry for purposes of political repression.

At the end of his professional life, Ey returned to his home in Catalonia, France, but remained active. There he wrote the *Traité des hallucinations* (Treatise on hallucinations; 1973), in which he devotes an important chapter to the psychodynamic study of hallucinations and, in an organodynamic approach to psychosis, introduces the concept of the “psychic body.”

JEAN GARRABÉ

*See also:* Colloque sur l'inconscient; Dalbiez, Roland; France; *Évolution psychiatrique* (L-); Ontogenesis; Phenomenology and psychoanalysis; Psychogenesis/organogenesis.

### **Bibliography**

Bonnafé, Lucien; Ey, Henri; Follin, Sven; Lacan, Jacques; and Rouart, Julien. (1950). *Le problème de la psychogenèse des névroses et des psychoses*. Paris: Desclée de Brouwer.

Ey, Henri. (1939). Réflexions sur la valeur scientifique et morale de la psychanalyse: à propos de la thèse de Roland Dalbiez. *Encéphale*, 34 (4), 189–220.

———. (1966). *L'inconscient: VIe colloque de Bonneval, 1960*. Paris: Desclée de Brouwer.

———. (1973). *Traité des hallucinations*. Paris: Masson.

———. (1975). *Des idées de Jackson à un modèle organodynamique en psychiatrie*. Toulouse, France: Privat.

Ey, Henri; Bernard, Paul; and Brisset, Charles. (1960). *Manuel de psychiatrie*. Paris: Masson.

Ey, Henri, and Rouart, Julien. (1938). *Essai d'application des principes de Jackson à une conception dynamique de la neuropsychiatrie*. Paris: Doin.

Freud, Sigmund. (1953). *On aphasia: A critical study* (E. Stengel, Trans.). New York: International Universities Press. (Original work published 1891)

# FE

## FACE-TO-FACE SITUATION

The expression *face-to-face situation* is used to describe the sitting arrangement in psychotherapy, as opposed to psychoanalysis where the patient is on the couch facing away from the psychoanalyst.

Sigmund Freud's prescription is clear as early as 1904 when he wrote, in "Freud's Psycho-Analytic Procedure," "Without exerting any other kind of influence he [the analyst] has them [patients] lie down in a comfortable attitude on a sofa, while he himself sits on a chair behind them outside their field of vision" (p. 250). He was even more explicit in 1913 when he wrote, in "On Beginning the Treatment (Technique of Psycho-Analysis)," "I must say a word about a certain ceremonial which concerns the position in which the treatment is carried out. I hold to the plan of getting the patient to lie on a sofa while I sit behind him out of his sight. This arrangement has a historical basis; it is the remnant of the hypnotic method out of which psycho-analysis was evolved. But it deserves to be maintained for many reasons. The first is a personal motive, but one which others may share with me. I cannot put up with being stared at by other people for eight hours a day (or more). Since, while I am listening to the patient, I, too, give myself over to the current of my unconscious thoughts, I do not wish my expressions of face to give the patient material for interpretations or to influence him in what he tells me. The patient usually regards being made to adopt this position as a hardship and rebels against it, especially if the instinct for looking (scopophilia) plays an important part in his neurosis. I insist on this procedure, however, for its purpose and result are to prevent the transference from mingling with the patient's associations

imperceptibly, to isolate the transference and to allow it to come forward in due course sharply defined as a resistance" (pp. 133–134).

The patient's obligation to lie down, according to the *fundamental rule*, is the second of the two main conditions of treatment that Freud expressed to the Rat Man, who quickly attempted to transgress it (Freud, 1909). Sixteen years later, Freud returned to this issue with Smiley Blanton, as the latter's *Diary of My Analysis with Freud* (1971) reveals: "The position is only a matter of convenience, but one point remains essential: The analysand must not see the analyst's face. If it were otherwise, the analyst's expression would influence him." In *The Fabric of Affect in the Psychoanalytic Discourse*, André Green writes: "Analytic speech is speech delivered lying down . . . addressed to a *hidden partner*" (1999 [1973], pp. 232–233).

The broadening of the types of cases in which psychoanalytic treatment has been deemed possible (psychosis, drug addiction, borderline personality disorders, behavioral disorders, and so on) has modified this previously inflexible rule and led to proposals that certain treatments take place face-to-face, known as "psychoanalytically inspired psychotherapies" (Held). Such therapies have been seen as a means of controlling the narcissistic regression to which the reclining position on the couch is conducive, along with the feelings of depersonalization, overwhelming anxiety states, or mechanisms of defensive rigidification it can entail. A more rational verbalization is thus encouraged; only psychotics are truly uninhibited in communicating their delusional fantasies in face-to-face situations. Better mastery over terrifying impulses to destroy the object can be achieved because of the



constant possibility of seeing that the object—here represented by the therapist via the transference—is still present and intact (which at times necessitates, on the part of the therapist, a no less effective mastery over his or her own countertransference anxieties).

The visual *gaze* intervenes less often as a satisfaction of voyeuristic or exhibitionistic drives than as a testament to the vigilance and security felt by a patient who does not have to fantasize the presence, behind him or her, of an invisible power who sits in judgment and can at any time, without warning, unleash punishment or destruction. The making or avoidance of eye contact is a harder burden for the therapist to bear than for the patient, as Freud noted; behind their elaboration, the crudest countertransference affects are liable at any time to manifest themselves in body language, facial expressions, or a change in attitude that patients unfailingly perceive and interpret.

Can psychoanalytic treatment, in the full sense of the term, take place in the face-to-face situation? Opinion is divided on this issue, although the majority of authors believe that the blocking of fantasies and the difficulty of developing a transference neurosis within a face-to-face situation make it unlikely that an authentic psychoanalytic process can be established. Certain practitioners begin treatment of difficult cases with a period of face-to-face interaction, or insert into classical treatment an interval of face-to-face interaction, which may vary in length, when excessive anxiety makes it dangerous to proceed with treatment within a strictly defined psychoanalytic setting. Such an approach can also be put forward with patients who return to see a psychoanalyst after having finished with classical analysis—a situation that is now increasingly in demand—and, in these cases, must address the often excessive length of treatment and the maintenance of an idealized transference (whether positive or negative) that has been insufficiently analyzed.

In current practice, it is increasingly common for psychoanalysts to interact with patients face-to-face, particularly when only temporary support is required or because a current life event—a trauma, for example—calls for a type of help that remains on the surface of the psychic processes, “at the level of the ego,” to use an accepted phrase.

In the face-to-face situation, where all the parameters of a permanent erotic-aggressive confrontation seem to converge to produce a pure and simple repeti-

tion of a patient’s archaic relational modalities, it is above all important that the psychoanalyst’s listening and physical perception of verbal and intraverbal reality, beyond any reductive fantasmatic project, bring the patient a progressive and profound refutation of their life-sustaining certainty that “nothing can change” and that he or she would run tremendous risks by giving up habitual defenses.

*See also:* Analytical psychology; Psychoanalytic treatment; Psychotherapy.

### **Bibliography**

- Blanton, Smiley. (1971). *Diary of my analysis with Freud*. New York: Hawthorn.
- Brusset, Bernard. (1991 May–June). L’or et le cuivre. La psychothérapie peut-elle être et rester psychanalytique? *Revue française de psychanalyse*, 55 (3).
- Freud, Sigmund. (1904a [1903]). Freud’s psycho-analytic procedure. *SE*, 7: 247–254.
- . (1909d). Notes upon a case of obsessional neurosis. *SE*, 10: 151–318.
- . (1913c). On beginning the treatment (Further recommendations on technique of psycho-analysis I). *SE*, 12: 121–144.
- Green, André. (1999 [1973]). *The fabric of affect in the psychoanalytic discourse*. London and New York: Routledge.
- Held, René. (1964–1965) Rapport clinique sur les psychothérapies d’inspiration psychanalytique freudienne. *Revue française de psychanalyse*, 28 (special number).
- Weissman, Stephen M. (1977). Face to face: The role of vision and the smiling response. *Psychoanalytic Study of the Child*, 32, 421–450.

---

## **FACILITATION**

*Facilitation* refers to the repeated passage of an excitation along the same pathway; this brings about a gradual and permanent decrease in resistance to this progression, and thus this channel develops into the preferred pathway for future excitations.

This term was used very early by Sigmund Freud (1888r, 1892g, 1893k). In the first article, Freud contrasts “facilitation and inhibition” to “reflex” and, in the two other articles, he separates “facilitation” and

“inhibition” as the two modes of reflex transmission. The maximal usage of the term, as defined above, is found in Freud’s 1895 “Project for a Scientific Psychology,” with its neurological model of mental functioning.

Josef Breuer, in the *Studies on Hysteria* (1895), mentions the “attentional facilitation” invoked by Sigmund Exner (1894), who was dealing with the problem of energy and considered attentional facilitation to be pathological. In the “Project for a Scientific Psychology,” Freud reworked the same notion differently to describe learning operations at the level of the “w neurons” and the memory, which tends to establish a type of operations similar to those of the  $\psi$  system governed by the principle of inertia. In this text, facilitation is conceived as a sort of double of the process of cathexis, the other important element in the management of bound energy.

Subsequently, Freud all but abandoned the term *facilitation*, which he uses only three times in *The Interpretation of Dreams* (1900a), where he opposes it to “resistance,” and a final time in “Beyond the Pleasure Principle” (1920g), where facilitation is defined as a “permanent trace of the excitation” (p. 26) obtained through a decrease in the resistance against the progression of excitation.

BERTRAND VICHYN

See also: Binding/unbinding of the instincts; Hypercathexis; “Project for a Scientific Psychology”; Psi system; Signifier; Signifying chain.

### Bibliography

Breuer, Josef, and Sigmund Freud (1895d). Studies on hysteria. *SE*, 2: 48–106.

Exner, Sigmund. (1894). *Entwurf zu einer physiologischen Erklärung der psychischen Erscheinungen*. Vienna.

Freud, Sigmund. (1888r). Rezension von: Phisalix, [Césaire-Auguste], Sur les nerfs craniens d’un embryon humain de trente-deux jours (Compt. rend. CIV, 4, p. 241). In: *Zbl. Physiol.*, Bd. 1, S. 268.

———. (1892g). Rezension von: Sternberg, [Maximilian], Hemmung, Ermüdung und Bahnung der Sehnenreflexe im Rückenmark (Wiener Akad. Sitzber. Juni 1891). In: *Zbl. Physiol.*, Bd. 5, S. 859f.

———. (1893k). Rezension von: Sternberg, M[aximilian], Über die Beziehungen der Sehnenreflexe zum Muskeltonus

(Wiener Akad. Sitzber. Juni 1891). In: *Zbl. Physiol.*, Bd. 6, S. 24.

———. (1900a). The interpretation of dreams. Part I, *SE*, 4: 1–338; Part II, *SE*, 5: 339–625.

———. (1920g). Beyond the pleasure principle. *SE*, 18: 7–64.

———. (1950c [1895]). Project for a scientific psychology. *SE*, 1: 281–387.

### FAKEL (DIE-)

A Viennese satirical review published by Karl Kraus, *Die Fackel* (The Torch) played an important role in the intellectual life of the early twentieth century. From April 1899 until February 1936, it appeared three times a month, then at least once every four months. Kraus published it by himself and was the only writer on the review’s staff after 1911. His primary target was the press and its promoters, who were the servants of the moneyed classes. Kraus was in favor of sexual freedom and an ethic of right-speech. Because of his antimilitarist position during the First World War, the publication was censored. A number of Kraus’s articles and aphorisms have been collected in anthologies.

Sigmund Freud, who was already a reader of the publication in 1903, is quoted in it for the first time in 1905 with reference to his *Three Essays on the Theory of Sexuality*. In 1906 *Die Fackel* sided with Freud when he was accused of plagiarism by Wilhelm Fliess. Freud wanted to “join forces with Kraus,” who showed an appreciation for Freud even though believing that art is more important than science and expressing reservations about the interpretation of dreams.

The tone changed in 1910 after Fritz Wittels, who had been a prolific contributor to the publication, presented a paper at the Vienna Psychoanalytic Society entitled “The Neurosis of the *Torch*,” in which he caricatures Kraus’s aversion to the *Neue Freie Presse* as an expression of a desire to kill his father. Kraus then sharpened his barbs against psychoanalysis in aphorisms such as, “Psychoanalysis is a mental disease for which it assumes it is the therapy” (no. 376, June 1913).

ERIK PORGE

See also: Austria, Wittels, Fritz (Sigfried).

**Source Citation**

*Die Fackel*. (H. Fischer, Ed.). Munich: Kösel Verlag, 1968–1973, nos. 1–922, 39 vols.

**Bibliography**

- Kaufholz-Messmer, Eliane. (1975). *Karl Kraus*. Paris: Editions de l'Herne.
- Kraus, Karl. (1985). *Pro domo et mundo*. Paris: Gérard Lebovici.
- . (1986). *La nuit venue*. Paris: Gérard Lebovici.
- Nunberg, Hermann, and Federn, Ernst (Eds.). (1962–1975). *Minutes of the Vienna Psychoanalytic Society*. New York: International Universities Press.
- Waldvogel, A. (1990). Karl Kraus und die Psychoanalyse: eine historisch-dokumentarische Untersuchung. *Psyche: Zeitschrift für Psychoanalyse und ihre Anwendungen*, 44(5), 412–444.

**FAILURE NEUROSIS**

The nosographical category of failure neurosis was created and applied mainly in France, as a result of René Laforgue's writings. It is defined in his book *Psychopathologie de l'échec* (The psychopathology of failure; 1941): "We thus speak of the failure of an individual's emotional life or social activity[...]. The person derives from the affective failure itself the strength and the voluptuousness that transforms the unhappiness into happiness."

He used the concept in *L'échec de Baudelaire* (The defeat of baudelaire; 1931), and in chapter eleven of *Clinique psychanalytique* (Clinical aspects of psychoanalysis; 1936/1984) he described it as a specific nosographical category. He was then criticized by Edward Glover in 1939 for following the current trend among French psychoanalysts of isolating multiple clinical syndromes without putting much effort into systematizing them into general categories. Although the chapters devoted to Napoleon and Hitler disappeared mysteriously during the troubled period of the Second World War, his book, which appeared in 1941, took Jean-Jacques Rousseau and Robespierre as examples in order to review and develop the psychopathological variations that clinicians encounter. Laforgue also pointed to Freud's treatment of the subject: "Freud was the first to speak of this syndrome in a short article on *Those Wrecked*

by *Success* but he did not accord to the question all the importance it deserved."

Freud did indeed describe this "character-type" among the causes of resistance to the symptom analysis (1916d). Taking the examples of Lady Macbeth and Rebecca West, a character in Ibsen's *Rosmersholm*, he showed how guilt linked to the possible realization of forbidden desires could lead to a failure as soon as the consciously desired goal was achieved in reality. Laforgue continued this oedipal theme, elaborating it from the notion of the superego (which he called the super-I). Because of his work on "family neurosis" (another syndrome that has since been forgotten), he considered the family environment important.

Failure as "fear of success" translates psychically into inhibitions, depression, even delusions, or physically into clumsiness or accidents of varying degrees, perhaps even fatal. These disorders can correspond to punishment for transgressing a prohibition (appearing after a significant success) or the impossibility of successfully completing a task required by the ego ideal. Other forms have been linked to survivor guilt after the death of a highly cathected object or a catastrophic experience (the Holocaust, for example). These states are usually accompanied by a depressed tone but, as Roy Schafer pointed out, we must be careful not to see all these subjects as "masochists" because this description would imply a sexualization of suffering, which is not always present.

The notion of "fate neurosis," which is quite vague, somewhat clouded the issue of the failure syndrome, which suffered further decline after the Liberation, during the debates around *The Psychopathology of Failure*, first published in 1941 and reprinted in 1944 despite the fact that it was rejected by Matthias Göring, from whom Laforgue had requested a translation. Certain considerations, like "this love of suffering, whether it translates as persecution or worrying about money, is one of the characteristic aspects of the Jewish psychism, as it developed in the ghettos" (1941, p. 42), helped discredit this theory, and since 1945 it has received only rare and brief mention in psychoanalytic literature, being generally associated with studies of adolescence (Mâle; Weil).

ALAIN DE MIJOLLA

See also: Laforgue, René; Neurosis; *Psychopathologie de l'échec* (Psychopathology of failure).

### Bibliography

- Freud, Sigmund. (1916d). Some character-types met with in psycho-analytic work. *SE*, 14: 309–333.
- . (1923b). The ego and the id. *SE*, 19: 1–66.
- Glover, Edward. (1939). Review of *Clinical aspects of psychoanalysis*, by René Laforgue, Hogarth and Inst. Psycho-Anal., London, 1938. *International Journal of Psycho-Analysis*, 20, 196–197.
- Laforgue, René. (1941). *Psychopathologie de l'échec*. Marseille: Les Cahiers du Sud.
- Laforgue, René. (1984). *Clinical aspects of psycho-analysis* (Joan Hall, Trans.). New York: Da Capo. (Original work published 1936)
- Mâle, Pierre. (1971). Quelques aspects de la psychopathologie et de la psychothérapie à l'adolescence. *Confrontations psychiatriques*, 7, 103–124.
- Schafer, Roy. (1988). Those wrecked by success. In Robert A. Glick and Donald I. Meyers (Eds.), *Masochism: Contemporary psychoanalytic perspective* (pp. 81–92). Hillsdale, NJ: Analytic Press.
- Weil, Annemarie P. (1978). Maturational variations and genetic-dynamic issues. *Journal of the American Psychoanalytic Association*, 26, 461–491.

## FAIRBAIRN, WILLIAM RONALD DODDS (1889–1964)

British physician and psychoanalyst William Ronald Dodds Fairbairn was born in Edinburgh on August 11, 1889, and died there on December 31, 1964.

Ronald Fairbairn was the only child of middle-class parents with strict Protestant morals and strong academic traditions in Scotland. He studied moral philosophy at Edinburgh University, and divinity and Hellenistic Greek at Edinburgh, Kiel, Strasbourg and Manchester.

Fairbairn made the decision to study medicine and psychotherapy after serving in the First World War. As a medical student he started analysis with E. H. Connell, and shortly after qualifying began thirty years of working with war neuroses. Despite being without the requisite formal training, he began psychoanalytic work in 1925 and obtained his MD in 1927. In 1926 he married and began a family; he started his clinical writing soon after. From 1927 to 1935 he was a lecturer in psychology at Edinburgh University, his special subject being adolescence, and held a post at the Clinic for

Children and Juveniles where he treated the delinquent and sexually abused.

He was introduced to the British Psycho-Analytical Society by both Ernest Jones and Edward Glover, who admired his thinking and intellectual rigor. Fairbairn was elected as associate member of the British Psycho-Analytical Society after presenting a paper to the Society in 1931. He became a full member in 1938.

During the Second World War he held a post in the Emergency Medical Service, and later a government post, while beginning to publish his most important contributions. Isolated from the conflicts in the British Psycho-Analytical Society, he was able to develop his original and independent ideas, and towards the end of his life was increasingly recognized. Fairbairn's first wife died in 1952, and he remarried in 1959.

Fairbairn's principal contributions can be found in his book *Psychoanalytic Studies of the Personality* (1952), and his article "An Object Relation Theory of the Personality" (1954). Several of these contributions are outlined below.

Fairbairn moved from a biological model to a psychological one, in which the early unitary ego is genetically geared towards object relationships. Energy is inseparable from structure in this model, and "drive" is seen as the struggle for integration, individuation and recognition within a human environment.

He described a theory of development based on a maturational sequence of relationships throughout life, from infantile dependence to "mature dependence." To this he added a theory of endopsychic structure and its development, in which the ego, as it becomes attached to different (ideal, exciting, rejecting) aspects of mother, internalizes them and splits (this is the "schizoid condition," inevitable and basic). The ego divides into a "central" ego, partly conscious and available for real relationships; a "libidinal" ego; and an "antilibidinal" ("internal saboteur") ego, both unconscious. The central ego also internalizes what Fairbairn called the "ideal object," and in order to earn its approbation develops the "moral defense" of guilt; it is the central ego, operating in the "real world" and also in touch with inner structures, that can mediate between them and lead to the opening up of the inner world to reality.

Fairbairn also developed a theory of psychopathology based on real environmental failure, in which the infant internalizes and identifies with the bad aspects

of its parent(s), and represses the relationships, together with memory, fantasy, and attached affect. The type and severity of psychopathology depends on the degree of splitting and repression required, the defenses against it, and the amount of remaining central ego available for external relationships. Here there are implications for psychoanalytic technique, particularly in the understanding of repetition compulsion.

One of the most important founders of object-relations theory, Fairbairn left work that has been increasingly influential, both in the United Kingdom and internationally. Those particularly influenced include members of the British Independent Group, attachment theorists, self-psychologists, and intersubjective theorists.

JENNIFER JOHNS

*Notions developed:* Antilibidinal ego; Quasi-independence/transitional stage.

*See also:* Breast, good/bad object; Great Britain; Libido; Object relations theory; Self (true/false).

### **Bibliography**

Fairbairn, Ronald. (1952). *Psychoanalytic studies of the personality*. London: Tavistock Publications.

———. (1994). *From instinct to self: Selected papers of W. R. D. Fairbairn: Vol. 1, Clinical and theoretical papers*. (David Scharff and Ellinor Fairbairn Birtles, Eds.). New Jersey: Jason Aronson.

———. (1994). *From instinct to self: Selected papers of W. R. D. Fairbairn: Vol. 2, Applications and early contributions*. (David Scharff and Ellinor Fairbairn Birtles, Eds.). New Jersey: Jason Aronson.

Greenberg, Stephen, and Mitchell, Jay. (1983). *Object relations in psychoanalytic theory*. Cambridge, MA, and London: Harvard University Press.

Grotstein, James, and Rinsley, Donald (Eds.). (1994). *Fairbairn and the origins of object relations*. London: Free Association Press and New York: The Guilford Press.

Sutherland, John. (1989). *Fairbairn's journey into the interior*. London: Free Association Press.

---

## **FALSE SELF**

The false self, in Donald Winnicott's developmental schema, refers to certain types of false personalities that develop as the result of early and repeated environmental

failure, with the result that the true self-potential is not realized, but hidden. This idea appears in many papers and is fully presented in "The theory of infant-parent relationship" (Winnicott, 1965c).

From 1945 onward Winnicott described the infant's development. In the earliest object relationships the infant is most of the time unintegrated and absolutely dependent, requiring at first the mother's totally reliable and empathic response (primary maternal preoccupation). Later the infant accepts her gradual but tolerable failures in provision (good enough mothering) and proceeds to ego integration and relative dependence. "Not good enough mothers," those who are unable to satisfy the excited infant's needs or who demand an inappropriately integrated response from an infant unable to give it, Winnicott describes as impinging and traumatizing. When repeated traumas occur very early in development, the infant experiences extreme dread or primitive agony, and psychosis may result. To such a mother, who fails to meet the infant's gesture and substitutes one of her own, the older and more integrated infant responds in a compliant fashion. In this way the infant may develop a false self that builds up a set of relationships based on compliance or even imitation, the potential true self being unrealized and hidden.

Winnicott described five degrees of false self. In the extreme case, the true self is completely hidden, and the false self appears authentic and is frequently successful, though failing in intimate relationships. In nearly normal cases, the false self is bound by the ordinary restraints necessary for social adaptation. Winnicott emphasizes a particular type of false self in which intellectual activity is dissociated from psychosomatic existence.

Winnicott is elusive in style, because he writes from an object-related point of view. In this viewpoint, the undifferentiated infant ego exists from the beginning in a relationship without knowing it, because the sense of self and other does not yet exist. Winnicott's developmental approach, of which the concept of a false self is one aspect, differs from those of Freud and Klein. He does not directly address instincts in themselves, for instance, since his focus is on the developing and dynamic relationship between what will become the individual and the environment in which that individual will grow. His theory parallels but also differs from that of Fairbairn. On Fairbairn's theory, environmental failure and lack of early intimacy must result in

defensive splitting, schizoid mechanisms being the most basic. From there, there are many subsequent possibilities in terms of character development and psychopathology. Winnicott held that one can ameliorate false-self organizations of personality only by facilitating regression in analysis.

JENNIFER JOHNS

*See also:* As if personality; Internal object; Lie; Normality; Self (true/false); Splitting.

### **Bibliography**

- Winnicott, Donald W. (1945). Primitive emotional development. *International Journal of Psycho-Analysis*, 26. (Reprinted in his *Collected papers: through paediatrics to psycho-analysis* [1958].)
- . (1958). Psychosis and child care. In his *Collected papers: through paediatrics to psycho-analysis* (pp. 219–228). London: Tavistock Publications. (Original work published 1952)
- . (1965a). Ego distortion in terms of true and false self. In his *Maturational processes and the facilitating environment* (pp. 140–152). London: Hogarth and the Institute of Psycho-Analysis. (Original work published 1962)
- . (1965b). Ego-integration in child development. In his *Maturational processes and the facilitating environment* (pp. 56–63). (Original work published 1962)
- . (1965c). The theory of infant-parent relationship. In his *Maturational processes and the facilitating environment* (pp. 17–55). London: Hogarth and the Institute of Psycho-Analysis. (Original work published 1960)
- . (1975). *Through paediatrics to psycho-analysis*. London: Hogarth Press and the Institute of Psycho-Analysis.
- . (1989). Development of the theme of the mother's unconscious as discovered in psycho-analytic practice. In his *Psychoanalytic explorations* (pp. 247–250). Cambridge, MA: Harvard University Press.

## **FAMILY**

Family is usually defined as a group of persons related by marriage or blood ties, or even by adoption—and also by the family bond.

Psychoanalysis contains an implicit concept of family. It emphasizes the functions of each family member and the prescriptions and prohibitions governing the relationships between them, which influence conflicts, fantasies, and the psychic agencies.

The family is a unit that consists of something more than a series of individuals; it is a group to which they belong and that provides support with its rules, which are as obscure and powerful as those of the unconscious and that thus ensure the family's coherence and cohesion. The family has many purposes: providing for its members' material and psychic needs and conceiving and developing the child until his accession as a subject. Each parent transmits a legacy that the child will have to negotiate in connection with its wishes. The family also has a function in terms of play, creating the space and time for leisure and reverie.

Before Freud, doctors took little interest in the family. The patient was studied in the present, without reference to childhood history, to the context in which he had developed, or to his father or mother, except to identify any hereditary predispositions that would reinforce the prevailing hypothesis concerning degeneration in mental patients. Freud raised the family to a preeminent position. However, after he quickly abandoned the seduction theory, the family headed by a seducer changed its status from a real entity to a theoretical fantasy. Freud still addressed the family as a real entity in the form of the primal horde (1912–1913a), with the authoritarian father put to death by his sons who were excluded from sharing the women. Freud subsequently returned to this hypothesis as to the origin of culture. For example, his group psychology (1921c) helped to explain family psychology. It may even be that he envisaged the functioning of the group and the crowd as an archaic family dominated by a leader (father) at whom his subjects direct their (ego) ideal cathexes. This model bears a curious resemblance to the family of ancient Rome, in which the father was the uncontested leader around whom the life of the household revolved. There are some revealing exceptions to this lack of interest in the real family, for instance, the account that the child's father gives to Freud in the analysis of "Little Hans" (1909b). It was not unusual at the time for a single analyst to treat different members of the same family.

As the real family receded from the picture, the representations of the parents gained ground, particularly through the increased interest in object relations. The shifting importance of the family relates to developments in the theory of trauma. However, the real problem is discovering not whether the original theory of trauma was definitively abandoned by Freud but whether it was given anything

other than a factual status. It would then not simply be the presence of the object or the primary maternal care that contributed to introjections but the parent's subjectivity, desires, fantasies, and affects—in other words, the force of his unconscious desire, which orients the child's ideals by proposing an ideal that reinforces his self-esteem when he experiences it as an important part of himself and which awakens the life of the drives by seducing him.

The analytic theory of the family is based on this model. It addresses the way in which the reciprocal cathexes between its members are managed and mobilized. Donald Winnicott explained this unconscious functioning as a productive network of interrelated fantasies giving rise to a generative illusion on the part of the mother and her child, whose attuned psyches are connected by primary narcissistic identifications. This generates the concept of the bond: An object relationship would be inconceivable without its counterpart, in other words, without the cathexis that the external object creates of the former and applies to him (Eiguer, 1987).

Furthermore, the concept of the bond is complicated by the dual nature of filiation. The family romance (Freud, 1909c [1908]) is a fantasy in which the child gives himself another origin by imagining himself to be adopted or illegitimate. While assuaging his oedipal anxieties, he seeks, by inventing better or prestigious parents for himself, to preserve the previous idealization of his own parents. However, in giving himself other parents (or one other) than his own, he acknowledges an essential dimension of filiation: The parental roles are not equivalent to the procreative functions—they can even be independent of these. In matrilineal cultures in particular, the father's role of strict educator reverts to an uncle who is related to the mother. Although Freud's discovery relates to a set of fantasies, this nevertheless accords with the idea of an underlying imago-based structure. The transgenerational figure of the ancestor ultimately evokes this spiritual fatherhood in the other of the father, the fourth family member.

ALBERTO EIGUER

*See also:* Collective psychology; Intergenerational; Law of the Father; Psychoanalytic family therapy; Secret; Sociology and psychoanalysis, sociopsychanalysis.

## Bibliography

- Eiguer, Alberto. (1987). *La Parenté fantasmatique*. Paris: Dunod.
- Freud, Sigmund. (1909b). Analysis of a phobia in a five-year-old boy. *SE*, 10: 1–149.
- . (1909c [1908]) Family romances. *SE*, 9: 235–241.
- . (1912–1913a). Totem and taboo. *SE*, 13: 1–161.
- . (1921c). Group psychology and the analysis of the ego. *SE*, 18: 65–143.
- Laforgue, René. (1936). La névrose familiale (IXe Conférence des psychanalystes de langue française). *Revue française de psychanalyse*, 9 (4), 327–359.
- Winnicott, Donald W. (1965). *The maturational processes and the facilitating environment*. London: Hogarth and the Institute of Psychoanalysis.

---

**FAMILY COMPLEX.** *See Imago*

---

## FAMILY ROMANCE

The family romance is a conscious fantasy, later repressed, in which a child imagines that their birth parents are not actual but adoptive parents, or that their birth was the outcome of maternal infidelity. Typically, the fantasy parents are of noble lineage, or at least of a higher social class than the real parents.

The family romance (Freud, 1909c[1908]) differs from children's sexual theories in that it does not address general questions about the origins of life but rather the question, "Who am I?"—where "I" denotes not an agency of the mind (or ego) but the result of an effort to place oneself in a history, and hence the attempt to form the basis of a knowledge.

The family romance fantasy has several possible aims and sources: revenge against frustrating parents; rivalry with the parent of the same sex; separation from idealized parents by means of their transformation into fantasy parents; and the elimination of brothers and sisters for competitive or incestuous purposes.

The family romance is built on the basis of the child's intuitive knowledge of their parents' emotions, although the parents may believe these perfectly con-

cealed (see Freud, *Totem and Taboo* [1912–1913a]; also, apropos of the paranoid's intuitiveness, "Some Neurotic Mechanisms in Jealousy, Paranoia and Homosexuality" [1922b [1921]]).

Other intellectual capacities are necessary for the creation of a family romance, notably the ability to compare and to relativize. The fantasy may thus be considered the result of a basic psychological attainment, that of the right to doubt—here, to doubt the absolute aspect of parental figures ("*Pater semper incertus est*"). The family romance is, in fact, linked to the unconscious of the parents. For the father, there can be only one true father, his own, that of the "primal horde"; while the mother associates her child psychologically, particularly her first-born, with her own oedipal attachments (Mijolla). This first childhood romance is often maintained in daydreams well beyond puberty. Its influence is also discernible in the pleasure novel-readers derive by identifying with different fictional characters.

SOPHIE DE MIJOLLA-MELLOR

*See also:* Cultural transmission; Family; Fantasy; Heroic self, the; Imposter; Latency period; *Myth of the Birth of the Hero*; Myth of the hero; Mythology and psychoanalysis; Substitute/substitutive formation.

### **Bibliography**

Freud, Sigmund. (1909c [1908]). Family romances. *SE*, 9: 235–241.

———. (1912–13a)]. Totem and taboo. *SE*, 13: 1–161.

———. (1922b [1921]). Neurotic mechanisms in jealousy, paranoia and homosexuality, *SE*, 18: 221–232.

Mijolla, Alain de. (1987). Unconscious identification, fantasies and family prehistory. *International Journal of Psychoanalysis*, 68, 397–403.

### **Further Reading**

Corbett, Ken. (2001). Nontraditional family romance. *Psychoanalytic Quarterly*, 70, 599–624.

Greenacre, Phyllis. (1958). The family romance of the artist. *Psychoanalytic Study of the Child*, 13, 9–36.

## **FANON, FRANTZ (1925–1961)**

Frantz Fanon was born on July 20, 1925, in Fort-de-France on the Caribbean island of Martinique and died on December 6, 1961, in Washington, D.C. He is best known for his work in fighting against colonization.

Fanon was the son of a native Martiniquan father (the descendant of slaves and a member of the island's middle-class community), and a French (Alsace) mother (herself the daughter of a mixed marriage). Between 1939 and 1943 he studied at the Lycée Schoelcher, where he was taught by Aimé Césaire, a poet who helped destroy the image of the African created by European colonization. In 1943, then a young man, Fanon became a dissident and agitated against representatives of the Vichy regime in the Antilles. He traveled to the island of Dominica to rally the free French forces in the Caribbean. In 1944 he fought on the European front. Wounded near the Swiss border, he received a citation for his courage, signed by Colonel Raoul Salan, whom he would later fight against in Algeria.

After receiving his baccalaureate at the special session of March 1946, he went to Lyon, France, to study medicine (1946–1951). After a brief stay in Martinique at the end of 1951, he returned to Lyon to specialize in psychiatry under the direction of Professor Tosquelles. There he met Octave Mannoni. The two men became friends, but Fanon was highly critical of Mannoni's *Psychologie de la Colonisation* (Psychology of colonization). He became a psychiatrist in June 1953. In 1954 he was appointed to a post in Blida, Algeria. He saw patients during the day and, at night, participated in the struggle for Algerian independence. He was expelled from Algeria in January 1957. At the end of the summer of 1958, Fanon settled in Tunis to resume his double life. He died in 1961 from leukemia.

He developed an interest in psychoanalysis fairly early in his career; he speaks of it in his first book, *Black Skin, White Masks* (1967a), published when he was twenty-seven. His attitude is that of a colonized subject who, disappointed by racism, grows skeptical of European universalism. Yet he began this work with the following statement: "Only a psychoanalytic interpretation of the black problem can reveal the emotional anomalies responsible for the resulting complexes." Fanon saw Sigmund Freud, Alfred Adler, and Carl Gustav Jung as more or less the same. His form of psychoanalysis is more of a social therapy based on liberation than of a talking cure.

**FAMILY THERAPY.** *See* Psychoanalytic family therapy



His ideas, as represented in his books—*Studies in a Dying Colonialism* (1965a), *The Wretched of the Earth* (1965a), and *Toward the African Revolution* (1967b)—can be summarized as follows: There is a specific pathology associated with colonization. The core of the emotional disturbances affecting black people is an inferiority complex, in the Adlerian sense. The Oedipus complex does not occur in families from the Antilles. The unconscious, as described by Jung, is collective. Analysis of the social-historical development of the individual must take precedence over any other approach. Freud, Jung, and Adler were not thinking about black people when they formulated their theories. He rejected the idea of determinism, believing that humankind was abandoned to its own fate.

He was unable to overcome his resistance to psychoanalysis at the time of his premature death at the age of thirty-six.

GUILLAUME SURÉNA

See also: Martinique; North African countries.

### Bibliography

- Cherki, Alice. (2000). *Frantz Fanon, portrait*. Paris: Seuil.
- Fanon, Frantz. (1965a). *Studies in a dying colonialism* (Haakon Chevalier, Trans.). New York: Monthly Review Press. (Original work published 1958)
- . (1965b). *The wretched of the earth* (Constance Farrington, Trans.). New York: Grove Press. (Original work published 1961)
- . (1967a). *Black skin, white masks* (Charles Lam Markmann, Trans.). New York: Grove Press. (Original work published 1952)
- . (1967b). *Toward the African revolution: Political essays* (Haakon Chevalier, Trans.). New York: Grove Press. (Original work published 1964)

## FANTASY

A fantasy is a product of the imagination in the form of a script in the theatrical or cinematic sense and deployed in support of a wish-fulfillment. It may be a conscious creation, a daydream created by the subject to procure an imaginary satisfaction that is erotic, aggressive, self-flattering, or self-aggrandizing in nature. This wish-fulfilling function likens the daydream, or reverie, to night dreams, but it may also be com-

pared to symptoms or behavior with similar aims. It must therefore be supposed that all these manifestations have a common origin, namely unconscious fantasy.

The term *Phantasie* was part of everyday language, where it signified “fancy,” “imagination.” It appeared very early in Freud’s writings, notably in the *Studies on Hysteria* (1895d), where he noted the frequency of daydreams among hysterics. However, the word soon took on a more precise meaning and the concept was expanded centrally in the burgeoning science of psychoanalysis. In a letter dated May 2, 1897, to Wilhelm Fliess, Freud wrote, “I have gained a sure inkling of the structure of hysteria. Everything goes back to the reproduction of scenes. Some can be obtained directly, others always by way of fantasies set up in front of them. The fantasies stem from things that have been heard but understood *subsequently*, and all their material is of course genuine.” (p. 239). Later, in Draft M (May 25, 1897), we find this: “Fantasies arise from an unconscious combination of things experienced and heard, according to certain tendencies. These tendencies are toward making inaccessible the memory from which symptoms have emerged or might emerge. . . . As a result of the construction of fantasies like this (in periods of excitation), the mnemonic symptoms cease” (1985a [1887–1904], p. 247).

Already, then, at this early moment, Freud posited unconscious fantasy as the source of the symptom, of the dream (soon to be elaborated on in *The Interpretation of Dreams*, 1900a), of daydreams, parapraxes, and so on. But the claim that “all [this] material is of course genuine” was significantly revised. On September 21, 1897, he famously announced to Fliess, “I no longer believe in my *neurotica*” (p. 264)—that is, in an etiology for hysteria attributable in all cases to a trauma actually experienced during childhood. This is not to say that Freud now abandoned his seduction theory. But in the wake of a sudden disillusionment, he entered a long period leading to his recognition that the traumatic event was never recorded exactly per se, and never endured in unmodified form but, quite to the contrary, was subject to incessant reworking after the fact. From that moment, indeed, Freud was convinced that “there are no ‘indications of reality’ in the unconscious, so that one cannot distinguish between truth and fiction that has been cathected with affect” (p. 264); or in other words between historical (or event-defined) reality and fantasy. It was possible,

then, that in some cases the hysterical symptom was the product of “pure fantasy”; seduction nevertheless existed, especially in view of the fact that a child might read this connotation into “innocent” events.

The birth of the psychoanalytical concept of fantasy may thus be dated 1897; in Freud’s self-analysis, its advent coincides with that of the Oedipus complex. As Freud wrote to Fliess on October 15, 1897, “I have found, in my own case too, [the phenomenon of] being in love with my mother and jealous of my father, and I now consider it a universal event in early childhood” (p. 272). This twin birth was acknowledged by Freud a quarter of a century later in *An Autobiographical Study* (1925d): “When, however, I was at last obliged to recognize that these scenes of seduction had never taken place, and that they were only phantasies which my patients had made up or which I myself had perhaps forced upon them, I was for some time completely at a loss. . . . When I had pulled myself together, I was able to draw the right conclusions from my discovery: namely, that the neurotic symptoms were not related directly to actual events but to wishful phantasies, and that as far as the neurosis was concerned psychical reality was of more importance than material reality. . . . I had in fact stumbled for the first time upon the Oedipus complex” (p. 34).

There are references to fantasy throughout Freud’s work, especially prior to the major theoretical revision of the 1920s. In his paper on “Screen Memories” (1899a), he revealed the role of adolescent fantasies in the work of reconstructing childhood memories. *The Interpretation of Dreams* (1900a), based on the idea of the dream as a wish-fulfillment, was itself a study of nighttime expressions of fantasy, while *Delusions and Dreams in Jensen’s “Gradiva”* (1907a) and “Creative Writers and Day-Dreaming” (1908e) were centered on the eruptions of fantasy during waking life. “Hysterical Phantasies and their Relation to Bisexuality” (1908a) was a reconsideration, ten years after its initial formulation, of the theory of symptom production through fantasy. In spite of its title, “On the Sexual Theories of Children” (1908c) also examined the role of fantasy: certain “theories” were constructed by the child to explain the mysteries of sexuality, conception, and birth, but they were in effect also imaginary productions similar to reveries. In the “Wolf Man” case history (1918b [1914]), Freud, returning at length to the problem of the relationship between event-defined “historical reality” and fantasy creation, ended by

re-embracing the notion of “phylogenetically” transmitted primal fantasies, previously discussed in *Totem and Taboo* (1912–1913a). Of special importance too is the essay “A Child is Being Beaten” (1919e), where Freud analyzed the genesis and structure of a particular fantasy in which erotic pleasure was tied to the evocation of punishment experienced by a (different) child.

The notion of fantasy nevertheless remained rather vague in Freud’s work. It presented a number of problems for him, especially that of the relationship between fantasy and representation. More generally, there was the question of the role played by fantasy in mentation. For Freud, the instinct was the living source of all mental activity, as he clearly asserted in *The Interpretation of Dreams*. The dream was a wish-fulfillment, but the dual action of primary processes and secondary revision could bring about transpositions and distortions that permitted the latent thoughts of the dream to cross over into the dream’s manifest content, to transform from unconscious fantasies into explicit images better able to break through the barrier of the censorship. In Chapter 7 of *The Interpretation*, Freud extended this model to psychic work as a whole in order to account for the transition from fantasy to mental representation, which were closely akin because of their common origin. The result, paradoxically, was that the difference between them was clearly pointed up: whereas the fantasy was an internal formation, created without reference to reality, mental representations drew their very substance from their relationship with the outside world. In “Formulations on the Two Principles of Mental Functioning” (1911b), Freud reiterated that fantasy served the pleasure principle exclusively, while mental representation, though it might transpose fantasy, answered strictly by the reality principle. Both the close kinship and the basic difference between fantasy and mental representation are easy to discern in Freud’s account of hallucinatory wish-fulfillment, where he describes that founding moment when the infant obtains satisfaction by hallucinating the real, but absent, agent of satisfaction, and then, since the need remains, begins to “represent” that absence (the representation of the object arises from its very absence). W. R. Bion was a leader among those authors who have sought to thus develop a theory of mental activity designed to illuminate the relationship between fantasy and representation.

The fact remains that back in 1897 Freud ran into a difficulty that continued to occupy him for the rest of his life and is still a crucial question for psychoanalysis in the twenty-first century: If instinctual forces are indeed the live source of wishes or fantasies, which mediate them, how can the forms of those wishes be explained, and more specifically how is it that *typical* forms, seemingly derived from a common matrix, occur very widely among people whose history and psychic make-up vary considerably? Freud posed this question repeatedly in his account of the “Wolf Man” (1918b [1914]), where he offered a meticulous, albeit hypothetical reconstruction of events that took place in his patient’s life between the ages of eighteen months and four years old in order to explain his subsequent pathology. Yet Freud continued to feel that such an explanation, based on a person’s real history, left something to be desired. He consequently appealed to an even earlier “historical reality”—that of the human species as a whole: “It seems to me quite possible that all the things that are told to us today in analysis as phantasy . . . were once real occurrences in the primaeval times of the human family, and that children in their phantasies are simply filling in the gaps in individual truth with prehistoric truth” (1916–1917a, p. 371). This echoed the “fiction” Freud had developed in *Totem and Taboo* (1912–1913a) according to which, at the time of the “primal horde,” the sons killed their father and committed incest with their mother; ever since, the unconscious memory of that primal drama has left its stamp on every human being.

It is not unreasonable to have reservations about this speculation. Nevertheless, clinical psychoanalysis has verified the role of “fantasies” that can be qualified as “primal,” however one regards their historicity, in that they are the basis of every individual fantasy. Freud mentioned three varieties: “I call such fantasies—of the observation of sexual intercourse between the parents, of seduction, of castration, and others—‘primal fantasies’” (1915f, p. 269). But this enumeration should not be looked upon as definitive; it should no doubt include the fantasy of a return to the mother’s breast (for further discussion of primal fantasies, see Laplanche and Pontalis).

Among post-Freudian developments, Melanie Klein’s contribution is the most important. Continuing the line of enquiry that Freud opened up in “Instincts and Their Vicissitudes” (1915c) and reorganized after 1920 by introducing the life and death

instincts, Klein assigned a leading role to the play of fantasy in the mental life of young children; indeed, she even seemed to make the apprehension of reality subordinate to fantasy in the context of a battle royal between love and hate that aroused massive anxiety. The beginning of mental life was envisaged by Klein as the scene of a tragedy played out by fantasies of invasion, cannibalism, deadly attacks on the breast and by the breast, explosion, laceration, and so forth. This approach was further advanced by some of Klein’s followers, notably Donald Meltzer. Significant theoretical support was supplied by Susan Isaacs in her paper “On the Nature and Function of Phantasy” (1948).

A very different approach was taken by Jacques Lacan, who compared fantasy to freezing the frame of a moving picture. In contrast to the Kleinian view, the emphasis here was on the defensive function of fantasies, which sought to “freeze” the evocation of violent scenes, and first and foremost those responsible for castration anxiety. For Lacan, the neurotic fantasy was an attempt, always fruitless, to respond to the enigma of the desire of the other. However varied individual expressions of fantasy themes might be, the aim of analysis was always to circumscribe the typical basic fantasy of each analysand, its place and role in the symbolic structure that determined that analysand’s particular mode of gratification (*jouissance*).

Michèle Perron-Borelli (1997) has taken an entirely different tack, providing a general overview of fantasy in the context of an original theoretical reformulation of the problem. Noting that every fantasy is centered on a representation of action, whether active in nature (e.g., seducing) or passive (being seduced), she defines fantasy in terms of a three-part structure comprised of an agent, an action, and an object of the action. This structure is analogous, for Perron-Borelli, to the basic grammatical subject/verb/object pattern; this is no accident, perhaps, if one accepts that language reflects the development of thought itself, and its origins in fantasy. All fantasy activity, therefore, and indeed all thought, may be conceived of as a system of transformations of this basic structure by a variety of means: changing of places by the subject and the object relative to the action (change from activity to passivity or vice versa), the replacement of the object or the subject, the assumption by the subject of the viewpoint of an outside observer; and so on. In this view, the subject comes into being and develops by virtue of these transformations themselves. At a deeper level, the starting-

point is sought in a “primal fantasy matrix” in the autoerotic life of the infant.

ROGER PERRON

*See also:* Act/action; Adolescent crisis; Amnesia; Anxiety; Archaic mother; Autism; Body image; Castration complex; Combined parental figure; Creativity; Depression; Family; Fantasy, formula of; Fantasy (reverie); Graph of Desire; Group analysis; Idea/representation; Identification; Identification fantasies; Internal/external reality; Internal object; Masochism; Myth of origins; Mythology and psychoanalysis; Need for causality; *Neurotica*; Object *a*; Oedipus complex, early; Perversion; Phallic woman; Pregnancy, fantasy of; Primal fantasies; Primal scene; Primal, the; Projective identification; Real trauma; Reparation; Rescue fantasies; Reverie; Screen memory; Seduction scenes; Symptom-formation; Unconscious fantasy; “Vagina dentata,” fantasy of.

### Bibliography

- Fain, Michel. (1971). Prélude à la vie fantasmatique. *Revue française de psychanalyse* 35 (2–3), 291–364.
- Freud, Sigmund. (1899a). Screen memories. *SE*, 3: 299–322.
- . (1900a). The interpretation of dreams. *SE*, 4–5.
- . (1907a). Delusions and dreams in Jensen’s “Gravida.” *SE*, 9: 1–95.
- . (1908a). Hysterical phantasies and their relation to bisexuality. *SE*, 9: 156–166.
- . (1908c). On the sexual theories of children. *SE*, 9: 205–226.
- . (1908e). Creative writers and day-dreaming. *SE*, 9: 141–153.
- . (1911b). Formulations on the two principles of mental functioning. *SE*, 12: 213–226.
- . (1912–13a). Totem and taboo. *SE*, 13: 1–161.
- . (1915c). Instincts and their vicissitudes. *SE*, 14: 109–140.
- . (1915f). A case of paranoia running counter to the psycho-analytic theory of the disease. *SE*, 14: 261–272.
- . (1916–17a). Introductory lectures on psychoanalysis. *SE*, 15–16.
- . (1918b [1914]). From the history of an infantile neurosis. *SE*, 17: 1–122.
- . (1919e). “A child is being beaten”: A contribution to the study of the origin of sexual perversions. *SE*, 17: 175–204.

———. (1925d [1924]). An autobiographical study. *SE*, 20: 1–74.

———. (1985c [1887–1904]). *The complete letters of Sigmund Freud to Wilhelm Fliess, 1887–1904* (Jeffrey Moussaieff Masson, Ed. and Trans.). Cambridge, MA: Belknap/Harvard University Press.

Freud, Sigmund, and Breuer, Joseph. (1895d). Studies on hysteria. *SE*, 2: 48–106.

Isaacs, Susan. (1948). On the nature and function of phantasy. *International Journal of Psycho-Analysis*, 29, 73–97.

Laplanche, Jean, and Pontalis, Jean-Bertrand. (1968). Fantasy and the origins of sexuality. *International Journal of Psycho-Analysis*, 49, 1ff. (Original work published 1964)

Perron-Borelli, Michèle. (1997). *Dynamique du fantasme*. Paris: Presses Universitaires de France.

Perron-Borelli, Michèle, and Perron, Roger. (1997). *Fantasme, Action, Pensée*. Algiers: Éditions de la Société algérienne de psychologie.

### Further Reading

- Hayman, Arlene. (1989). What do we mean by a “phantasy”? *International Journal of Psychoanalysis*, 70, 105–114.
- Sandler, Joseph, and Sandler, Anne-Marie. (1994). Phantasy and its transformations: A contemporary Freudian view. *International Journal of Psychoanalysis*, 75, 387–394.
- Shapiro, Theodore. (1990). Unconscious fantasy: Introduction. *Journal of the American Psychoanalytic Association*, 38, 39–46.

## FANTASY, FORMULA OF

In his early seminars, especially *Object Relations* (1956–57), Jacques Lacan primarily conceived of fantasy as deriving from psychic projection that screened a more painful image. He compared it to a freeze-frame, where an immobile image is often used to conceal the traumatic image that will come next. Thus he first conceived of fantasy as a defensive structure designed to protect against the perception of “lack” in the maternal other, thus of castration. A study of the different forms of the fantasmatic defense allow for a better understanding of psychical structures.

Following leads found in Freud’s writings—especially “The Wolf Man” (1918b [1914]) and “A Child is Being Beaten” (1919e)—Lacan questioned the

relation between the fantasy and fixation on perceptual traces. He also addressed the larger question of memory. He determined that fantasy need not be radically opposed to memory. Instead, he suggested that fantasy might rework memory depending on the pressure of unconscious desire and the defensive strategies of the subject. Thus Lacan stressed that fantasy fundamentally worked to transform memories of real events.

In particular, he emphasized that the subject is always represented in fantasy, as in the dream, in a more or less obvious way. In fact, the fantasy stages a certain relation and mode of interaction between the subject and the object of desire. Thus conceived, fantasy is a complex structure, a kind of scenario, as opposed to the simple hallucination of an object. Lacan proposed a general formula for it:  $\$ \diamond a$ . Here the diamond,  $\diamond$ , formalizes the specific relation that the subject of the unconscious,  $\$$ , which is “divided” by its relation to the realm of signifiers, maintains with the object “little *a*,” the “lost” object, the “detached” remainder of the first operation of symbolization by the parental other. The famous list of Freudian “detachable” objects (breast, feces, penis, baby), to which Lacan added the voice, the gaze, and the phōneme, all constitute object-causes of desire (objects *a*) that are not representable as such. The subject will spend all his or her life searching for various imaginary and concrete intermediary objects to take their place in the realization of desire.

In April 1961, in his seminar on the *Transference*, Lacan tried to define the various types of fantasies: The hysteric aspires to a master. The obsessional’s fantasy involves an indefinite metonymic substitution. And the pervert’s fantasy seeks to radicalize the subject/other split, so that it can be enjoyed; this fantasy tends to take the form  $a \diamond \$$ .

In his fundamental text, “The Subversion of the Subject and the Dialectic of Desire in the Freudian Unconscious” (1960), Lacan tried to place fantasy in the genesis of the psychic apparatus by locating it within his “graph of desire.” The major difficulty here is that the object of the drive, the object of physiological need, and the object of narcissistic love/hate maintain with each other a relation of fundamental and irreducible heterogeneity.

For Lacan, the psychoanalytic treatment must locate the subject’s more or less unconscious

“fundamental fantasy.” At the same time the subject’s particular mode of enjoyment is exposed, and freed as much as possible from the desire of the Other, in relation to which the fantasy is always a compromise formation. The objective of any treatment is always to produce a change in the subject’s defensive processes, to remove obstacles in order to allow the subject access to his or her own enjoyment.

Lacan fully recognized the power of the image in fantasy, but he insisted on the fact that its functional value derives from the place that it comes to occupy in the larger symbolic structure. In other words, its value derives from the fact that the image in question (a representation of something unconscious) must be able to play its role as a signifier. On this point, Lacan launched an unceasing attack on (primarily Kleinian) currents in psychoanalysis that tended to consider the fantasy as a production of images that were assumed to be symbols in their own right. He devoted an entire year of his seminar (*The Logic of Fantasy*, 1966–67) to unraveling the theoretical implications of the inscription of fantasy in the unconscious signifying structure. Most notably, he insisted that fantasy would perform the essential function of “knotting” the psychological registers of the symbolic, the imaginary, and the real—and thus of constituting what Freud called “psychic reality.”

BERNARD PENOT

See also: Fantasy.

### Bibliography

- Lacan, Jacques. (1991). *Le Séminaire-Livre VIII, Le Transfert*. (1960–61). Paris: Seuil.
- . 1994. *Le Séminaire-Livre IV, La Relation d’objet*. (1956–57). Paris: Seuil.
- . (2002). *Écrits: A selection*. (Bruce Fink, Trans.). New York: W. W. Norton.
- . Unpublished. *Le Séminaire-Livre XIV, La Logique du fantasme*. (1966–1967).

---

## FANTASY (REVERIE)

The term *reverie* refers to an imaginary representation created to help realize a desire. The term *Phantasie* was used by Freud to designate such mental activity collectively, whether conscious or unconscious. In French

the term *fantasme* prevailed in psychoanalytic use, for it was felt that the term *fantaisie* was too marked by current usage, where it connotes the idea of capriciousness or gratuitousness. However, following Daniel Lagache (1964), the term *fantaisie* came to refer to imaginary conscious or preconscious creations, without ignoring their continuity with the unconscious fantasies they reflect.

Daydreams, which everyone experiences, are the clearest examples of conscious or preconscious reveries. In general they explicitly satisfy a desire, providing some form of imaginary satisfaction, whether it be erotic, aggressive, ambitious, self-aggrandizing, or uplifting. It is not even unusual for people to visualize painful or humiliating experiences to their own advantage. In all these cases the narcissistic dimension of the process is obvious.

There are references to such daydreams in the *Studies on Hysteria* (1895d), primarily in the case study of Anna O., written by Josef Breuer. Freud wrote about daydreams in *The Interpretation of Dreams* (1900a). For example, when analyzing his dream about the “botanical monograph,” he relates a daydream during which he imagines that, afflicted by glaucoma, he travels incognito to Berlin for an operation and experiences considerable pleasure in listening to the surgeon extol the anesthetic qualities of cocaine (thus being compensated for the pain Freud experienced through being too late to be recognized as the one who discovered its properties). The “fantasies (*Phantasien*), or daydreams, are the immediate predecessors of hysterical symptoms... Like dreams they are wish-fulfillments; like dreams they are based in large part on our infantile experiences; like dreams they enjoy a certain relaxation of the censorship for their creations.”

According to Freud, a daydream is initially the expression of an unconscious fantasy; then, it is used as available material among the latent thoughts used by dreams. However, as he noted, there is an essential difference between night dreams and daydreams: the first is hallucinatory, the second is not, and the person remains more or less clearly aware that his daydream is a an escape from a reality that is not completely suspended.

This distinction can be blurred or even disappear entirely. Freud analyzes this phenomenon in his detailed commentary on Wilhelm Jensen’s *Gradiva* (1907a). In the same period, in “Creative Writers and

Daydreaming” (1908e [1907]), he discusses the function of daydreaming in the genesis of the literary work, and later, in “Family Romances” (1909c [1908]), he foresees the situation where daydreams are used by the child to avoid the oedipal conflict by imagining himself to be adopted, to be really the child of a king and queen.

Robert Desoille (1961) developed an original method of psychotherapy based on the development and analysis of the patient’s daydreams during therapy. For some patients and under certain circumstances, analytic psychodrama can create scenarios that are related to daydreams.

ROGER PERRON

*See also:* “Creative Writers and Day-Dreaming”; Creativity; Ego ideal; Family romance; Fantasy; *Phylogenetic Fantasy, A: Overview of the Transference Neuroses, Psychoanalysis of Fire, The*; Reverie; Unconscious fantasy.

### Bibliography

- Anargyros-Klinger, Annie; Reiss-Schimmel, Ilana; Wainrib, Steve. (1998). *Création, psychanalyse*. Paris: Presses Universitaires de France.
- Desoille, Robert. (1961). *Théorie et Pratique du Rêve-éveillé-dirigé*. Geneva: Le Mont-Blanc.
- Lagache, Daniel. (1964). Fantaisie, réalité, vérité. *Revue française de psychanalyse*, 28 (4), 515–538.

---

## FASCINATION

Fascination commonly refers to the act of fascinating or of being fascinated. To fascinate is to immobilize by the power of the gaze; as well as to charm, enchant, dazzle, or even attract or capture someone else’s gaze.

In psychoanalysis the concept was used by Sigmund Freud to refer to the bondage of love. He used this term to refer to the paralysis of critical faculties, the dependence, docile submission, and credulity that occur when in love, which he compared to what occurs in the relationship between hypnotist and hypnotized.

The term appears for the first time in *Group Psychology and the Analysis of the Ego* (1921c). Fascination, or love bondage, is the term Freud uses to describe the most extreme developments of being in love. It is possible that he borrowed the term from Gustave Le Bon, whom he quotes and who had noted,

in *Psychologie des Foules*, that the individual in a crowd arrives at a particular state that approximates the fascination of the hypnotized for the hypnotist.

Although the first occurrence of the term *fascination* appears to date from 1921, what Freud describes is the result of earlier considerations that quickly led him to associate being in love with the hypnotic state. Already in 1890, in his article “Psychical, or Mental, Treatment,” (1890a) referring to the docility, obedience, and credulity of the hypnotized individual, he had noted that in a situation of this type “subjection on the part of one person towards another has only one parallel, though a complete one—namely in certain love-relationships where there is extreme devotion.” In 1910, in a note added to *Three Essays on the Theory of Sexuality* (1905d), he again points out this connection. In 1918, in “The Taboo of Virginity,” (1918a) he discusses the question of “sexual bondage,” the expression used by Richard von Krafft-Ebing to define the state of subjugation, dependence, and loss of will experienced during the course of a sexual relationship.

In 1921, what he describes with the term *fascination* is, therefore, not new, any more than the concordance he establishes between this state and that of hypnosis: the same paralysis of critical faculties, the same docility, the same submission toward the loved object or the hypnotist. These findings open the way to the problem of the imaginary relationship of the self to the loved Other or the authority figure, and lead one to believe that fascination is essential to the constitution of the ego—a thesis put forward by Jacques Lacan.

The function of the gaze is central to fascination, so it is surprising that the term doesn’t appear in the 1922 article on “Medusa’s Head” (1940c). The phenomenon is similar to the paralysis (of thought, judgment, and the body) caused, in the myth, by the encounter with the Gorgon. Here mortal hypnotic fascination reaches its apogee. The power of the gaze is the bearer and vector of the “omnipotence of thought,” like the phenomenon of the “evil eye” Freud had analyzed in 1919 in “The ‘Uncanny’” (1919h). It is also surprising that although, in 1916, he presents the goddess Baubo as a representation of castration, or interprets the Medusa’s head, along with Sándor Ferenczi, as a representation of the female genital organs and more specifically the mother, he never explicitly raises the question of fascination and what can cause it, namely, the sight of the

female genitals and the representation of castration they bring to mind.

CATHERINE DESPRATS-PÉQUIGNOT

See also: Idealization; Numinous (analytical psychology); *Qu’est-ce que la suggestion?*

### Bibliography

- Freud, Sigmund. (1890a). Psychical (or mental) treatment. *SE*, 7: 281–302.
- . (1905a). On psychotherapy. *SE*, 7: 255–268.
- . (1918a). The taboo of virginity. *SE*, 11: 191–208.
- . (1919h). The “uncanny.” *SE*, 17: 217–256.
- . (1921c). Group psychology and the analysis of the ego. *SE*, 18: 65–143.
- . (1940c). Medusa’s head. *SE*, 18: 273–274.
- Lacan, Jacques. (1975). *Le Séminaire-Livre I, Les Écrits techniques de Freud (1954–1955)*. Paris: Le Seuil.
- Le Bon, Gustave. (1995). *The crowd / Gustave Le Bon*. New Brunswick, NJ: Transaction Publications. (Original work published 1895)

---

## FATE NEUROSIS

Helene Deutsch developed the notion of “fate neurosis” on the basis of the notion of “compulsion of destiny” (*Schicksalszwang*), which Freud mentioned at the end of the third chapter of *Beyond the Pleasure Principle* (1920g, p. 23). In that work Freud described the following trait in nonneurotic people: “The impression they give is of being pursued by a malignant fate or possessed by some ‘daemonic’ power; but psychoanalysis has always taken the view that their fate is for the most part arranged by themselves and determined by early infantile influences. . . . Thus we have come across people all of whose human relationships have the same outcome: such as the benefactor who is abandoned in anger after a time by each of his *protégés*, however much they may otherwise differ from one another . . . or the man whose friendships all end in betrayal by his friend; . . . or again, the lover each of whose love affairs with a woman passes through the same phases and reaches the same conclusion” (pp. 21–22).

Helene Deutsch developed this clinical description beginning in 1930 in her paper “Hysterical Fate

Neurosis" (1965), in which she presented a case involving a such neurosis. Hysterical fate neurosis, she explained, "is a form of suffering imposed on the ego apparently by the outer world with a recurrent regularity. The real motive of this fate lies, as we have seen, in a constant, insoluble, inner conflict" (p. 27). She linked the neurosis to a lack of control over an anxiety-inducing childhood situation that arose during the genital phase.

The term *hysterical fate neurosis* then came to be used in a broader sense to describe individuals who lack neurotic symptoms but whose history is marked by repeated painful experiences.

Although some English-speaking writers have referred to this notion briefly, most psychoanalysts have moved away from a "psychopathology of fate" that could not be more clearly defined in metapsychological terms, despite the efforts of such authors as Jean Laplanche and Jean-Bertrand Pontalis. In the entry on fate neurosis in their *Language of Psychoanalysis* (1967/1974), they attempted to give it a more precise meaning and to distinguish it from "character neurosis," noting that the experiences characteristic of fate neurosis had to be "repeated despite their unpleasant character," had to "unfold according to an unchanging scenario," and had to "appear to be governed by an external fate, whose victim the subject feels himself—with seeming justification—to be" (p. 161).

Nevertheless, the notion of fate neurosis continues to be invoked, essentially for descriptive purposes, because it implies a holistic view of the individual, whose past, present, and future are more than a simple succession of random events.

ALAIN DE MIJOLLA

*See also:* *Beyond the Pleasure Principle*; Character neurosis; Deutsch-Rosenbach, Helene; Neurosis.

### **Bibliography**

Deutsch, Helene. (1965). Hysterical fate neurosis. In her *Neuroses and character types* (pp. 14–28). New York: International Universities Press. (Originally published 1930)

Freud, Sigmund. (1920g). Beyond the pleasure principle. *SE*, 18: 1–64.

Laplanche, Jean, and Pontalis, Jean-Bertrand. (1974). *The language of psycho-analysis* (Donald Nicholson-Smith, Trans.). New York: Norton. (Original work published 1967)

### **Further Reading**

Kaplan, Donald M. (1984). Helene Deutsch's 'hysterical fate neurosis' revisited. *Psychoanalytic Quarterly*, 53, 240–266.

---

## **FATHER COMPLEX**

The expression *father complex* was used by Sigmund Freud in the period 1910–1913 to designate feelings of guilt and of castration anxiety relating to the father, and therefore to the Oedipus complex.

The expression first appears in the article "The Future Prospects of Psycho-Analytic Therapy" (1910d), when Freud wrote that "in male patients the most important resistances in the treatment seem to be derived from the father complex and to express themselves in fear of the father, in defiance of the father and in disbelief of the father" (p. 144). He attributed specifically to Carl Gustav Jung the coinage of the term *complex*, and in the same year he used it in developing the expression "Oedipus complex," which was at this time nearly synonymous with "father complex."

The expression was hardly ever used by Freud again, except in *Totem and Taboo* (1912–13a), where it took on a more specific meaning. Here, in essence, it referred to the guilt and castration anxiety experienced by the son in the "primitive horde" after the murder of the father, which in turn led to the repression of incestuous wishes toward the mother. Transmitted from generation to generation, this complex explains the permanence and universality of the Oedipus complex.

The expression father complex has almost entirely disappeared from usage in contemporary psychoanalysis.

ROGER PERRON

*See also:* Oedipus complex.

### **Bibliography**

Freud, Sigmund. (1910d). The future prospects of psychoanalytic therapy. *SE*, 11: 139–151.

———. (1912–13a). Totem and taboo. *SE*, 13: 1–161.

---

**FATHER (NAME OF).** *See* Name-of-the-Father



## FATHERHOOD

Fatherhood has been described as the cause and fulfillment of the father's creative, protective, and organizing power in his child. As a physical and symbolic bond between generations, fatherhood implies the authority of the father over the child, expressed through the transmission of the name. The sons use this aspect of paternity in the construction of their own individual and social identities, and in their respect for the law. Fatherhood is the basis of all thought.

Discovering in his self-analysis, through his dreams, that fatherhood satisfied both his desire for immortality, through his children, as well as his ambivalence toward his own dead father, Sigmund Freud fathered psychoanalysis when he published *The Interpretation of Dreams*, and established that the desire of Oedipus to sleep with his mother and kill his father is universal.

Fatherhood is an organizing system indissociable from the Oedipus complex. It links the law to desire and to castration. It structures and restrains sexuality, through the father, who is simultaneously loved, protective, and feared. It condenses conflicts of ambivalence and the castration anxiety. Fatherhood induces repression and prompts progress: It is an inevitable and indestructible origin and obstacle that unites the scattered ego, while showing how to overcome ambivalence through identification with the father. Its dynamic potential is anchored in the father-mother-child triangle it structures, not in the person of the father who supports the paternal function. Hans (1909b), in the throes of an oedipal crisis at four years of age, introjects the cultural treasure linked to fatherhood into the mythical power of language and knowledge. He is ignorant of the procreative function: Paternity, as the hidden cause for the production of children, confutes childhood trust, obstructs independent thought, and betrays the subject's expectation of protection. A child affected by nostalgia for the father will displace it onto God.

Fatherhood was considered to have had a phylogenetic origin, recapitulated by ontogenesis (1912–13a). Having murdered the violent and jealous primal father, the sons discover the symbolic paternity of the father in the work of mourning, made up of ambivalence, guilt, and idealization. Retrospective obedience and the renunciation of the father's omnipotence are at the origin of the social contract and the law. For Freud fatherhood also occupies a central place in the subject's genital organization through the father com-

plex. Linked to death and sexuality, which it transcends, and serving as an atemporal and structuring reference point, it channels through its incarnated generating power the diphasic sexual development of the child-become-adolescent, opening him up to the effects of *Nachträglichkeit*, sublimation, and the wish to become a father in his turn.

Identification is the prototype of this operation; first, the human subject constitutes itself through "primal" identification with the "father of personal prehistory" (1923b), an incorporation of paternity that includes the mother. Fatherhood then, logically, enables the subject's separation from the mother and authorizes relations of generation, dramatized as arising from a primal triangle, with differentiated parental imagos. Secondly, the oedipal crisis ends, with the installation of the impersonal superego.

The bond with the father is essential for a daughter (1933a). Involved in an intense pregenital relation to her mother, she enters late into the Oedipus complex, turning her outwardly directed libido inwards. She displaces her love onto her father, from whom she wants a child-penis. Her major anxiety, that of being no longer loved, often keeps her dependent on her bond with the father. As a mother she offers fatherhood to the man who is substituting for her father, if she has transcended her own claim to the phallus.

The bond of fatherhood is connected for the child with the desire that links the mother to the father. Paternity exerts itself when the child induces a "foreigner" (1939a) who is the father to adoption. For Jacques Lacan, a failure of this metaphorizing recognition is responsible for the foreclosure of the Name-of-the-Father, which leads to psychosis. Melanie Klein prefigured the oedipal complex through the nipple-object guiding the child's access to the breast, a paternity incarnated at the very heart of maternity.

Fatherhood can be considered as a development when becoming a father leads to psychic restructuring.

ANN AUBERT-GODARD

*See also:* Abandonment; Adolescence; Animus-Anima; Bisexuality; Castration complex; Counter-Oedipus; Criminology and psychoanalysis; "*Disturbance of Memory on the Acropolis, A*"; "Dostoevsky and Parricide"; Eroto-genic masochism; Ethics; Family; Family romance; Father complex; Freud, Jakob Kolloman (or Keleman or

Kallamon); *Future of an Illusion, The*; Homosexuality; Idealization; Identification; Infantile neurosis; Law and psychoanalysis; Law of the father; *Leonardo da Vinci and a Memory of his Childhood*; Myth of origins; *Myth of the Birth of the Hero*; Neurotica; Object; Object, change of/choice of; Oedipus complex; Otherness; Parenthood; Parricide, murder of the father; Penis envy; Pregnancy, fantasy of; Primal scene; Primary identification; Primitive horde; Scenes of seduction; “Some Psychical Consequences of the Anatomical Distinction between the Sexes”; Superego; *Totem and Taboo*; Totem/totemism; Wish for a baby.

### **Bibliography**

- Freud, Sigmund. (1900a). The interpretation of dreams. Part I. *SE*, 4: 1–338; Part II. *SE*, 5: 339–625.
- . (1912–13a). Totem and taboo. *SE*, 13: 1–161.
- . (1933a [1932]). New introductory lectures on psycho-analysis. *SE*, 22: 1–182.
- . (1939a). Moses and monotheism: three essays. *SE*, 23: 1–137.
- Lacan, Jacques (1958). The signification of the phallus. In Alan Sheridan (Trans.), *Écrits: a selection* (pp. 281–291). New York: Tavistock Publications.

## **FAVEZ-BOUTONIER, JULIETTE (1903–1994)**

A psychoanalyst and teacher, Juliette Favez-Boutonier was born near Grasse, France, in 1903, and died in Paris on April 13, 1994.

The daughter of teachers in the Alpes-Maritimes, to which she returned nearly every year until her death, Favez-Boutonier studied in Grasse and Nice. She later traveled to Paris to study philosophy at the Sorbonne, for a while with Léon Brunschvicg. In 1926 she was one of the first women ever to take the state doctoral exam in philosophy. She was only twenty-three at the time.

She taught at schools in Chartres and Dijon, while studying medicine, which was a required preparation for anyone who wanted to practice psychology at the time. In 1930 she wrote to Sigmund Freud, who responded personally on April 11 that “philosophical problems and their formulation were so foreign to him that he didn’t know what to say.” In 1938 she wrote her doctoral dissertation on ambivalence (La notion d’ambivalence); the text was reprinted in 1972. In 1935 she obtained a job in Paris teaching

philosophy and it is here that she met Daniel Lagache and began analysis with René Laforgue, with whom she remained friends for many years. During the Occupation, Laforgue entrusted Favez-Boutonier with the Freud letters he had preserved.

At this time she met with members of the Société Psychanalytique de Paris (SPP, Paris Psychoanalytic Society) who had remained in Paris. John Leuba wrote to Ernest Jones on December 31, 1944, the day after the Liberation, that new analysts were now beginning to appear, including “Mlle Boutonier, a gifted physician and philosopher with a sound technique; she was monitored by me and I can confirm that she will be one of the first recruits.”

For Favez-Boutonier the relations between psychoanalysis and philosophy were complex and, in 1985, for the reprint of the memorable session held January 25, 1955, by the Société Française de Philosophie (French Philosophy Society), Juliette Favez-Boutonier wrote about her experience writing her thesis. Her thesis director was Gaston Bachelard, who was using psychoanalysis as a therapeutic method as well as a philosophy. She had said after the publication of her thesis that she was the first to explore Freudian psychoanalysis in a noncritical way, and she was grateful to Bachelard who allowed her to express her experience in psychoanalysis within her interest for psychology and philosophy. Her thesis, *Anxiety*, was published in 1945 by Presses Universitaires de France and, in 1947, was awarded the Prix Paul Pelliot “Junior.” The “Senior” prize went to Henri Wallon.

While working for the Centre national de la recherche scientifique (CNRS) she presented several papers to the SPP and was elected a member in 1946. Having trained in clinical psychopathology at the Sainte-Anne Hospital with Georges Heuyer, she was put in charge of the Centre Psychopédagogique Claude-Bernard, which had been created by Georges Mauco. She was soon replaced by André Berge, for that same year she was appointed professor in the humanities department at the University of Strasbourg.

Close to the circle of analysts around René Laforgue, she participated in meetings and contributed to *Psyché*, the review founded by Marie Choisy in 1946. She argued in favor of “assistant psychologists,” participated in the Section des Psychanalystes d’Enfants, and tried to promote the creation of psychoanalytic groups throughout the country, especially in Strasbourg. This led to a conflict with those who were

setting up the future Institut de Psychanalyse de Paris (Paris Institute for Psychoanalysis). In 1952 she married Georges Favez, one of the future presidents of the Association Psychanalytique de France (French Psychoanalytic Association).

She intervened on behalf of Mrs. Clark-Williams during her trial in 1951–1952, believing that “psychoanalysis was a psychological technique.” This position, joined to her opposition to what she referred to as the “dictatorship” of Sacha Nacht, grouped her with Daniel Lagache and Françoise Dolto at the beginning of the 1953 split in the French psychoanalytic establishment and subsequent creation of the Société Française de Psychanalyse (French Society for Psychoanalysis), of which she would become the first vice president. For ten years she shared the trials and tribulations of the Society in its attempts to join the International Psychoanalytic Association, and was president during its dissolution following the second split in 1964.

Along with her membership activities, she had her own practice and taught psychoanalysis. However, some of her most important work was done within the French school system. She was appointed a professor at the Sorbonne in 1955, where she held the chair of general psychology. Didier Anzieu succeeded her at the University of Strasbourg. Although she encouraged work on group psychology, her own interest was clinical psychology, basing many of her ideas on the subject on those of Daniel Lagache. She appointed Laforgue the head of her laboratory in 1958. Along with Jacques Gagey, Claude Prévost, and Pierre Fédida, she was recognized as a “clinical psychologist” in 1968 after helping with the creation of the department “des Sciences Humaines Cliniques,” which was opened at the University of Paris VII.

Favez-Boutonier’s long life and career were characterized by an intellectual depth and richness that drew from the wellsprings of philosophy and psychoanalysis, which helped to enrich her clinical work in psychology and psychopathology.

BERNARD GOLSE

*See also:* Association psychanalytique de France; Centre psychopédagogique Claude-Bernard; France; Société française de psychanalyse.

### **Bibliography**

Boutonier, Juliette. (1945) *L'Angoisse*. Paris: Presses Universitaires de France.

———. (1955). Séance du 25 janvier 1955 de la Société française de philosophie. In F. Pasche (Ed.), *Métapsychologie et Philosophie*, Paris: Les Belles Lettres.

## **FAVEZ, GEORGES (1901–1981)**

Georges Favez, a Swiss psychoanalyst, was born on February 15, 1901, in Lausanne, Switzerland, and died on February 15, 1981, in Paris. His family ran a gourmet food store. He had an older sister, who was unmarried when she died, and from his first marriage he had a daughter whose three children Favez adored.

After studying in Leipzig and Strasbourg, Favez wrote his theology dissertation on Luther and worked as a country pastor in a free evangelical church rather than in the national church of the canton of Vaud. In 1936 he resumed his studies in Geneva at the Institut de l'éducation (Institute of Education), then under the supervision of Edouard Claparède, but he failed to sit for the final exam, which he felt he did not need for his future career as a teacher and psychotherapist.

From 1936 to 1938 Favez stayed in Paris with Georges Heuyer. In 1940 he was analyzed by Heinz Hartmann in Lausanne. Shortly after the war broke out, Favez was mobilized, and his analyst went into hiding and later emigrated to the United States. Favez divided his time among his psychoanalytic practice, the Office médico-pédagogique (Medical-Pedagogical Office), and the Maison d'éducation de jeunes délinquents (Home for the Education of Young Delinquents) in Vennes, Switzerland.

During the first Congrès des aliénistes et neurologistes de langue française (Congress of Francophone Psychiatrists and Neurologists), held in Lausanne in 1946, Juliette Boutonier, André Berge, and Georges Mauco visited the first Centre psychopédagogique français (French Psychopedagogical Center) at the Lycée Claude-Bernard in Paris in preparation for its opening. It was at this time that Favez met Boutonier, who became his wife in 1952. He began making frequent trips to Paris as a consultant and colleague at the Claude-Bernard center. He commuted regularly between Lausanne and Paris, and underwent analysis with Sacha Nacht. He was elected a member of the Société psychanalytique de Paris (Paris Psychoanalytic Society) in 1948. After his (third) marriage in 1952 to Boutonier, he settled permanently in Paris, on rue Descartes.

At this time, at the home of either Favez or Françoise Dolto, Favez, together with Daniel and Marianne Lagache and Juliette Favez-Boutonier, formed the Société française de psychanalyse (SFP, French Society for Psychoanalysis). Jacques Lacan joined shortly after its formation. In 1964 the society split into two groups: the École freudienne de Paris (Freudian School of Paris), under the supervision of Jacques Lacan, and the Association psychanalytique de France (APF, French Psychoanalytic Association), presided over by Daniel Lagache. Favez was one of the most active partisans for the association.

Favez devoted a great deal of his energy to the Association psychanalytique de France. He was soon elected secretary of the selection committee (formerly the training committee), a position he held for many years, and was president in 1966–1967. He was convinced that the association had a role to play in the French psychoanalytic landscape.

In 1966 he began to issue a semiannual newsletter, which published the psychoanalytic talks of the APF and reports of association activity. He was actively engaged in the activities of teaching and transmission and helped train many APF students. He also did much to popularize psychoanalysis. For example, after the war he had a program on Radio-Lausanne and gave many talks during the Journées des centres psychopédagogiques (Festival of Psychopedagogic Centers) and at SFP and APF events.

In 1971 and 1974 he published two articles that are still considered important: “L’illusion et la désillusion dans la cure psychanalytique” and “La résistance dans l’analyse.” A number of his articles are collected in *Être psychanalyste* (1976).

Those who knew Favez remarked on his intelligence, depth, and intellectual clarity. In his work he constantly emphasized the framework of psychoanalytic therapy and the psychoanalyst’s thoroughness and resolve. He loved Bach and Mozart, had a wonderful sense of humor, and enjoyed lively discussion. He was, according to Didier Anzieu, a man who lived well. Firmly rooted in clinical practice, he liked to quote Charles Ferdinand Ramuz: “We die making claims about ideas before having made claims to things.” He died in Paris on February 15, 1981, the day of his eighth birthday.

In 1982 the APF journal *Documents et débats* devoted issue number twenty to Favez’s memory. It

included articles by Jean-Claude Lavie, René Henny, André Bourguignon, and François Gantheret, together with a biography by Didier Anzieu.

BERNARD GOLSE

*See also:* As if personality; Internal object; Normality; Self (true/false); Splitting.

### **Bibliography**

Favez, Georges. (1971). L’illusion et la désillusion dans la cure psychanalytique. *Nouvelle Revue de psychanalyse*, 4, 43–54. (Reprinted in his *Être psychanalyste* [1976])

———. (1974). La résistance dans l’analyse. *Nouvelle Revue de psychanalyse*, 10, 193–199. (Reprinted in his *Être psychanalyste* [1976])

———. (1976). *Être psychanalyste*. Paris: Dunod.

---

### **FAVREAU, JEAN ALPHONSE (1919–1993)**

Jean Alphonse Favreau, French psychoanalyst and psychiatrist, was born on February 5, 1919, in Bordeaux, France, and died on May 30, 1993, in Saint-Léger-aux-Bois, France. Favreau belonged to a Catholic family that originally came from Guadeloupe. His father, an obstetrician, became a professor of obstetrics at the Catholic medical faculty in Lille, France, where Jean Favreau began his medical training in 1938. His studies were interrupted by the Second World War. Demobilized in 1940, he finished his studies in medicine in Bordeaux and later in Paris. In Lille he had met Jeanne-Marie Lejenne, whom he married in 1947. A physician herself, she became a psychoanalyst in 1957 and died in 1988. They had six children.

Through the lectures (published in the *Journal de Médecine de Bordeaux*, June 1913) and books of Angélo Hesnard owned by his father, Favreau learned of Sigmund Freud’s theories and was won over. In 1945 he embarked upon what would become a three-year analysis with John Lueba. In 1948, under the supervision of Sacha Nacht and Marc Schlumberger, he began the analysis of his first patients. These cases, taken in the context of his hospital practice, he did for free, which he justified in terms of the poverty and somewhat utopian climate that prevailed in the postwar period. Viewing free practice as a way of experimenting with possibilities for treatment under a different political and economic regime, he focused his

research on the effect of free treatment on the development and resolution of the psychoanalytic process.

This spirit persisted in the orientation and management of the Centre de consultations et de traitements psychanalytiques (Center for Psychoanalytic Consultations and Treatment), which was founded by Sacha Nacht in 1954 and where Favreau served as head physician beginning in 1958. His prior institutional experience dated from 1948, when, with Pierre Mâle, he helped create a hospital service for children aged six to ten years that allowed psychoanalysts to treat not just children but also their families. In this context he gained work experience consulting with families and supervising the psychotherapeutic treatment of children. He worked in a similar capacity at the Centre de consultations et de traitements psychanalytiques until his death, although he was succeeded as director by Jean-Luc Donnet in 1989.

Favreau's work bears the imprint of his practice, since clinical experience remained at the heart of his theoretical contributions. Working from cases of adult analysands, he sought to elucidate the "fantastic" and metapsychological genesis of the psyche and its successive alterations. The birth of the psyche is traumatic, he believed. Hence the object of psychoanalysis is human nature, not psychopathology. He illustrated this point in a report on the psychoanalytic treatment of an alcoholic patient emphasizing process rather than results. This focus on process was an important consideration for him. He also focused on those aspects of the development of human sexuality that are most often passed over in silence because they are subjected to intense repression and give rise to shameful feelings that wound the subject's narcissism, aspects such as anal sexuality and our animal nature in general. In this regard, he, together with his wife, contributed an article titled "Considérations sur les anomalies du comportement sexuel chez l'animal" (Considerations on Anomalies in Sexual Behavior in Animals; 1964) to a book on animal psychiatry. He was guided in his theoretical work by Freudian metapsychology and granted considerable economic importance to the idea of *après-coup* (deferred action).

Favreau transmitted his knowledge of psychoanalysis to younger analysts through supervision groups and seminars. The oral mode of communication was well suited to his thought because it is closer than writing to the experience of treatment and the emergence of the unconscious. In his work one thus finds a

greater concentration on practical aspects of psychoanalysis (such as indications for treatment, the psychoanalytic process, and the training of psychoanalysts) than on purely theoretical issues. Nevertheless, his contributions to child psychoanalysis and the study of children's emotional problems remain remarkably relevant and sound. He constantly insisted that the basis of theory is the drives and language, and he ascribed a determining role to the dialectical relationship among anxiety, suffering, and pleasure. Favreau published twenty-two articles, many of them written collaboratively or given in the form of interviews—yet another indication of his personable style.

MARIE-THÉRÈSE MONTAGNIER

See also: France; Société psychanalytique de Paris and Institut de psychanalyse de Paris.

### Bibliography

- Favreau, D. (1990). Le désir d'enfant dans l'imaginaire de l'enseignement. *Études psychothérapeutiques, 1* (new series), 115–124.
- Favreau, Jean. (1964). Considérations sur les anomalies du comportement sexuel chez l'animal. In Abel Brion and Henri Ey (Eds.), *Psychiatrie animale* (pp. 265–281). Paris: Desclée, De Brouwer.
- . (1972). La formation des psychanalystes. *Études freudiennes, 5–6*, 51–72.
- Mâle, Pierre, and Favreau, Jean. (1959). Aspects actuels de la clinique et de la thérapeutique des troubles affectifs de l'enfant. *Psychiatrie de l'enfant, 2* (1), 148–195.
- Ruyer, Danièle. (1991). Psychanalyse et idéal thérapeutique (interview with Jean Favreau). *Revue Française de Psychanalyse, 55* (2), 501–509.
- Troisier, Hélène, and Favreau, Jean. (1990). Plaisir et jouissance: chemins et détours (interview with Jean Favreau). *Revue française de psychanalyse, 54* (1), 189–196.

### FEAR

The term *fear*, whose metapsychological status remains uncertain, was used by Freud, in contrast to *anxiety*, to refer to the reaction to some real danger. In several works Freud discussed the semantic relationship between the terms *Angst* (anxiety), *Furcht* (apprehension, fear), and *Schreck* (fright). For Freud the distinction between anxiety and fear relates primarily to its

object, a distinction found in his earliest writings. In an article from 1895, which discusses the distinguishing characteristics of phobias and obsessions, he differentiates phobias “according to the object of the fear,” while anxiety refers to the emotional state experienced by the subject, without reference to a specific object (1895c [1894]). Similarly, in 1916, in his *Introduction to Psychoanalysis* (1916–1917a [1915–1917]), Freud, referring to the use of these terms in popular speech, indicated that “anxiety is related to a state with no direct allusion to an object, while in fear the person’s attention is precisely focused on the object.”

In 1920, in *Beyond the Pleasure Principle* (1920g), Freud emphasized the difference between fear and anxiety in terms of their relation to danger: Anxiety is a state characterized by the expectation and preparation for a danger, “even if unknown,” while fear implies a determinate object. In *Inhibitions, Symptoms, and Anxiety* (1926d [1925]), he further insisted on the association of anxiety with a state of expectancy and the use of the term *fear*—“in keeping with current usage”—to represent the situation when anxiety has found an object.

We see that the term *fear* is quoted with reference primarily to contemporary language. According to Catherine Cyssau, fear has no means of representation and its object does not conform to the criteria for repression. Although the status of anxiety, as an affect, occurs early in the development of Freudian theory, fear is more uncertain and seems to fall mostly within the context of behavioral description. Moreover, the opposition between fear and anxiety is hardly ever mentioned in Freud’s later writings, especially in the *New Introductory Lectures on Psychoanalysis* (1933a [1932]), where the theory of anxiety is again discussed.

In fact, another concept appeared in 1916 in Freud’s writings, that of “*Realangst*,” which can be translated as “realistic anxiety” or “anxiety in the face of a real danger,” and which is contrasted with neurotic anxiety or the anxiety of desire. In the *Introduction to Psychoanalysis*, Freud emphasized the rational and comprehensive nature of realistic anxiety, triggered by the perception of an external danger, that is, under conditions that can give rise to fear. From then on the fundamental question, to which he would frequently return, was that of the conditions required for the emergence of anxiety, a signal triggered by an external or internal danger.

In post-Freudian work the concept of fear is essentially used to characterize certain infantile manifestations of anxiety. Anna Freud, in particular, insisted on the structural differentiation between archaic, or primitive, fears and the phobias. It is important to remember that the “fear of the stranger’s face,” which, as described by René Spitz, arises in the infant when it is between six and eight months old, raises the question of determining if this reaction should be interpreted as a realistic anxiety responding to an external danger—the face perceived as unknown—or if it is an expression of unpleasure and the internal threat caused by the absence of the maternal object.

Fright, or *Schreck*, which is associated in several Freudian texts with traumatic neurosis, corresponds to the effects of a danger for which the subject “is not prepared by an earlier state of anxiety” (1916–1917a [1915–1917]). Freud goes on to say that anxiety contains “something that protects against fright” (1920g).

Roger Dorey has remarked that Freud, in *The Interpretation of Dreams* (1900a), described, in contrast to the “primary experience of satisfaction,” an “experience of fright whose origin is external” and which leaves behind a painful memory trace that the primitive psychic apparatus tries to avoid. This flight before the memory of the present pain, is, according to Freud, the “model and first example of psychic repression.” Thus, the prototype of fright is nothing but the experience of object loss, an experience that submerges the primitive psychic apparatus in excitations it is unable to control. For Dorey this “painful memory image” of the absent object forms a representation that contributes to the formation of the primal unconscious.

CLAUDE BURSZTEJN

*See also:* “Analysis of a Phobia in a Five-year-old Boy” (Little Hans); Annihilation anxiety; Anxiety; Castration complex; Claustrophobia; “*Confusion of Tongues between Adults and the Child*”; Danger; Drive/instinct; Erythro-phobia (fear of blushing); Fright; Guilt, feeling of; Incest; Paranoid position; Phobia of committing impulsive acts; Phobias in children; Stranger, fear of.

### **Bibliography**

Cyssau, Catherine. (1997). La peur et les phobies: des névroses d’angoisse à l’hystérie d’angoisse. In A. Fine, A. Le Guen, A. Oppenheimer (Eds.), *Peurs et phobies*. Paris: P.U.F.

Dorey, Roger. (1988). *Le Désir de savoir*. Paris: Denoël.

Freud, Sigmund. (1895a [1894]). (1916–1917a [1915–1917]). Introductory lectures on psycho-analysis (Parts I and II). *SE*, 15–16.

———. (1920g). Beyond the pleasure principle. *SE*, 18: 1–64.

## FECES

In a letter of December 22, 1897, Sigmund Freud wrote to Wilhelm Fleiss: “[B]irth, miscarriage, and menstruation are all connected with the lavatory via the word Abort (Abortus)” (p. 240). In German this word does effectively carry these different meanings.

Freud was to further develop these reflections in his “Three Essays on the Theory of Sexuality” (1905d), where he describes the phases of libidinal development from birth onward. The retention of fecal matter initially corresponds with an intention to use it for masturbatory purposes. The whole meaning of the anal zone is thus reflected in the fact that “few neurotics are to be found without their special scatological practices, ceremonies, and so on, which they carefully keep secret” (p. 187).

However, another link, that between fecal matter and money, emerged in listening to the discourse of obsessive patients; this link is expressed in one of the traits of the anal character, avarice. Freud writes in “Dreams in Folklore” (1958 [1911]): “How old this connection between excrement and Gold is can be seen from an observation by Jeremias: gold, according to ancient oriental mythology, is the excrement of hell” (p. 187).

Based on these associations, Freud establishes a symbolic equation that he phrases as follows: “[I]n the products of the unconscious—spontaneous ideas, phantasies, and symptoms—the concepts *faeces* (money, gift), *baby* and *penis* are ill-distinguished from one another and are easily interchangeable” (p. 128). When the child perceives that woman does not have a penis, the latter is conceived as being detachable and is thus analogous to excrement when it is separated from the body. In the same text, Freud underscores the importance of this equivalence in terms of the object: “Defaecation affords the first occasion on which the child must decide between a narcissistic and an object-loving attitude. He either parts obediently with his faeces, ‘sacrifices’ them to his love,

or else retains them for purposes of auto-erotic satisfaction and later as a means of asserting his own will” (p. 130). The love object that must be renounced (the mother of childhood), the lost object, will be identified by the Unconscious with feces, the body’s most intimate product, which must necessarily be relinquished; this marks the onset of the dynamics of loss, mourning, and melancholia.

Returning to the connection between feces and money in “From the History of an Infantile Neurosis” (1918b [1914]), Freud emphasizes that an interest in money is libidinal rather than rational in character, and that it thus relates back to excremental pleasure. The various terms in the sequence *filth* = *money* = *gift* = *child* = *penis* are thus treated as synonyms and represented by shared symbols.

In his “New Introductory Lectures on Psychoanalysis” (1933a), Freud completed his views: According to infantile theories of sexuality, the child is born from the intestine as a piece of feces; defecation is the model for the act of being born. “A great part of anal erotism is thus carried over into a cathexis of the penis” (p. 101), he writes.

DOMINIQUE J. ARNOUX

*See also:* Alpha function; Autism; Beta-elements; Castration complex; Coprophilia; Partial drive; Pregnancy, fantasy of; Stammering; Symbolism; Unconscious concept.

## Bibliography

Freud, Sigmund. (1905d). Three essays on the theory of sexuality. *SE*, 7: 130–243.

———. (1916–1917e). On transformations of instinct as exemplified by anal erotism. *SE*, 17: 125–133.

———. (1918b [1914]). From the history of an infantile neurosis. *SE*, 17: 1–122.

———. (1933a). New introductory lectures on psychoanalysis. *SE*, 22: 1–182.

Freud, Sigmund, and Oppenheim, David. (1911). Dreams in folklore. *SE*, 12: 175–204.

## FECHNER, GUSTAV THEODOR (1801–1887)

Gustav Fechner, German physician, physicist, and philosopher, was born on April 19, 1801, in Gross-Sächen, Prussia, and died in Leipzig on November 18, 1887. Freud admired Fechner as the pioneer of psychophysics and a founder of scientific and experimental psy-

chology. Together with his boyhood friend Eduard Silberstein, Freud attended Fechner's lectures in Leipzig in 1874.

Fechner studied medicine at the University of Leipzig. While still a student, he began writing articles (under the pseudonym Dr. Mises) that satirized contemporary science, and he did not become a practicing physician after receiving his degree. Instead, he turned his interest to physics and mathematics. His research demonstrating the validity of Ohm's laws in relation to a galvanic current led to his appointment as professor of physics in 1834. About 1839 Fechner was forced to leave his academic post due to an eye ailment that he attributed to exhausting research in optics. In his diary, which has been preserved at the University of Leipzig, Fechner described his experiences while ill and the existential crisis and depression that followed.

In the wake of his illness, Fechner developed his interest in sensation, the relation of mind to body, and panpsychism. "The great G. T. Fechner," as Freud called him, was appointed professor of philosophy and anthropology in 1843. In the course of this second creative period, he set out the foundations of psychophysics, such as the Fechner-Weber law, by which he is remembered as a founder of experimental psychology. His two-volume *Elemente der Psychophysik* was published in 1860.

Fechner's ambitions extended beyond experimental research. He hoped to organize psychophysics and metaphysics in a way that united philosophy and the human sciences. Major works toward fulfilling this aim include his 1848 article on the pleasure principle and *Einige Ideen zur Schöpfungs- und Entwicklungsgeschichte des Organismen* (Certain ideas on the creation and development of organisms; 1873). In this latter work Fechner offers the "principle of constancy" to explain how a progressively ordered and structured system can evolve from a disorganized state, a notion that suggests Freud's famous formula, "Where id was there ego shall be." (In this sense Fechner was also a precursor of the theory of the ego's self-organization [see, for example, Prigogine and Glansdorff].) Although Fechner's works inspired Freud when he conceived his concepts of the pleasure principle and the death instinct (Nitzschke), a systematic study tends to demonstrate that they were separated by fundamental differences in outlook.

BERND NITZSCHKE

See also: Alpha function; Autism; Beta-elements; Castration complex; Coprophilia; Partial drive; Pregnancy, fantasy of; Stammering; Symbolism; Unconscious concept.

### Bibliography

Fechner, Gustav Theodor. (1848). Über das lustprinzip des handelns. *Zeitschrift für philosophie und philosophische kritik*, 19, 1–30; 163–194.

———. (1860). *Elemente der psychophysik*. Leipzig: Breitkopf und Härtel.

———. (1873). *Einige ideen zur schöpfungs- und entwicklungsgeschichte der organismen*. Leipzig: Bretkopf und Härtel.

Lowrie, Walter (Ed.). (1946). *Religion of a scientist: selections from Gustav Theodor Fechner*. New York: Pantheon.

Nitzschke, Bernd. (1989). Freud et Herbert Silberer: Hypothèses concernant le destinataire d'une lettre de Freud de 1922. *Revue internationale d'histoire de la psychanalyse*, 2, 267–277.

Prigogine, Ilya, and Glandsdorf, P. (1973). L'écart à l'équilibre interprété comme une source d'ordre structure dissipatives. *Bulletin de la classe des sciences*, 59, 672–702.

---

## FEDERACIÓN PSICOANALÍTICA DE AMÉRICA LATINA

Formerly known as the Coordinating Committee of Psychoanalytic Organizations of Latin America (COPAL), the Federación psicoanalítica de América latina (FePAL; Psychoanalytic Federation of Latin America) brings together the Latin American psychoanalytic societies recognized by the International Psychoanalytic Association (IPA).

FePAL's objectives are as follows: to stimulate the expansion of member societies and the development of the psychoanalytic movement throughout Latin America within the framework of the IPA's established rules and stated goals, without prejudice to the autonomy of the organizations in the federation; to represent the common interests of member societies and their associates before the IPA; to create a forum for scientific exchange through publications, congresses, and meetings, among other activities; to facilitate scholarly exchanges among member organizations, the establishment of teaching programs, and training criteria in the various institutes; to encourage the



spread of psychoanalysis in Latin America; and to develop and offer advice and assistance to the psychoanalytic movement in areas where there is no member organization.

The Third Latin American Psychoanalytic Congress (the two preceding congresses were held in Buenos Aires, Argentina, and São Paulo, Brazil) was held in Santiago, Chile, in 1960, under the aegis of the Chilean Psychoanalytic Association. Ignacio Matte-Blanco was president of the organizing committee. At the administrative meeting, the decision was made to establish a Coordinating Committee of Psychoanalytic Organizations of Latin America (COPAL), presided over by Arnaldo Rascovsky—a veritable impresario for the idea of bringing Latin America's psychoanalysts together as an association.

COPAL was provisionally made up of the representatives of the societies or groups present at the meeting: for Bogotá (Colombia), Carlos Plata Mújica; for Mexico City, Avelino González; for Montevideo (Uruguay), Willy Baranger; for Porto Alegre (Brazil), Cyro Martins; for Rio de Janeiro (Brazil; Sociedade Brasileira de Rio de Janeiro), Fabio Leito Lobo; for São Paulo, Darcy de Mendoça; for Santiago, Carlos Whiting D'Andurain; and for Buenos Aires, Arnaldo Rascovsky.

COPAL acted as a pressure group before the IPA and succeeded in gaining representation on the IPA's steering committee. Léon Grinberg was the first Latin American representative to sit on the steering committee, followed by Avelino González, from Mexico, and later Luiz Dahleim, from Brazil. They were in turn succeeded by Carlos Plata, from Colombia; David Liberman, from Argentina; and Paulo Grimaldi, from Brazil. Later, this trend toward authorizing Latin American participation on the committee stabilized, and Angel Garma was elected honorary vice president of the IPA. Latin America's active political presence in psychoanalysis worldwide led to the granting of two vice presidencies for that continent. Thanks to the active intervention of this group, led initially by COPAL and later by FePAL, Latin America has obtained three vice presidencies on the IPA's governing board. The first IPA congress in Latin America was held in Buenos Aires in 1989; the second was held in Santiago in 1999.

During the 1960s and 1970s, through the efforts of teaching analysts who traveled to various regions to disseminate psychoanalytic knowledge, COPAL was extremely effective in promoting the scientific devel-

opment of the discipline, particularly in areas where the discipline was not yet well developed.

The exercise of political power brought internal frictions to COPAL, and at the International Congress of Psychoanalysis held in New York in 1979, a meeting between the organization's governing authorities and its delegates led to the resignation of a number of dignitaries, not without expressions of tensions, attitudes, and demonstrations that became extremely subjective in the case of some participants. This institutional crisis led to a new organization with participation of the societies, established groups, and groups-in-formation. An assembly of delegates was convened in Rio de Janeiro on June 6, 1980; the delegates approved the statutes of a new organization called the Federación psicoanalítica de América latina (FePAL), charged with the scientific development of Latin American psychoanalysis and organization of its congresses and exchanges between various regions. Primacy was given to democratic participation, and an order of succession to leadership of FePAL was established and has been respected ever since. Since its inception, FePAL has organized ten congresses; it serves as the umbrella organization for psychoanalysis throughout Latin America.

The successive presidents of COPAL were: Arnaldo Rascovsky, Marie Langer, Santiago Ramirez, Carlos Plata Mújica, David Zimmermann, Willy Baranger, Darcy M. Uchoa, and Fernando Cesarman. FePAL's successive presidents include: Joel Zac, Fernando Cesarman, Néstor Goldstein, Victor Aiza, Fábio Antonio Herrmann, Eustachio Portella Nunes, Alberto Pereda, Saul Peña, Alejandro Tamez Morales, Guillermo Carvajal, and Cláudio Laks Eizirik (1998–2000).

As of 2004, the federation included twenty-seven societies and study groups. New realities and the need for a more flexible and representative structure that would benefit from a more active participation by the presidents of member organizations have prompted debate on the reform of FePAL's statutes. The congress held in September 2000 in Gramado, in the state of Rio Grande do Sul (Brazil) was organized around the theme of "Psychoanalysis and Culture: Between the Couch and the Community." The pre-congress teaching workshops held in conjunction with the congress and focusing on "Children and Adolescents," "Myths," and "OCAL" attracted increased participation. At a meeting in February 2000 in Manaus (Brazil) there was a new edition of the Clinical Meetings of FePAL-

NAIPAG to mark the opportunity for Latin American and North American psychoanalysts to come together to discuss their clinical material and to share and compare their experiences.

The federation is in negotiation with the European Psychoanalytical Federation (EPF) to resume and establish regularity in the scheduling of FePAL-EPF Clinical Meetings. FePAL's *Boletín* (Bulletin) is published every six months; the *Revista Latinoamericana de Psicoanálisis* (Latin American revue of psychoanalysis) was restructured in keeping with the format and policies of the main international psychoanalytic journals. FePAL offers societies and study groups the possibility of an annual scientific exchange with invited participants from other Latin American institutions, and is considering an exchange program with analysts in other regions.

In 1998, FEPAL held its XXII congress in Cartagena de las Indias, Colombia, whose title was Cumbre Psicoanalítica Latino-Americana (Latin American Psychoanalytic Summit), under the presidency of Guillermo Carvajal. Several international authors gave lectures. In 2000, its XXIII Congress was in Gramado, Brazil, about *Psicanálise e Cultura: Entre o Divã e a Comunidade* (Psychoanalysis and Culture: Between the Couch and the Community), under the presidency of Cláudio Laks Eizirik. This was an extremely well attended congress, where the leading authors of the analytic field were present, and psychoanalytic research and the history of psychoanalysis in Latin America, were formally included in the program, as well as joint discussions with outstanding members of Latin American culture. The XXIV Congress was in Montevideo, in 2002, under the presidency of Marcelo Viñar, having as main theme *Permanencias y Cambios en la Experiencia Psicoanalítica* (What is permanent and what changes in the psychoanalytic experience). This Congress privileged small groups discussions, was also very well attended and introduced sending previously all papers by disc to all those registered, so that there were no formal presentations, but immediate discussions among the participants. In 2004, the XXV Congress was held in Guadalajara, Mexico, under the presidency of Serápio Marcano, with the main theme *Psicoanálisis en Latinoamérica Hoy: Teoría y Práctica en tiempos de Crisis* (Psychoanalysis in Latin America Today: Theory and Practice in a Period of Crisis).

Several clinical meetings were organized, in recent years, with North American colleagues, which stimulated fruitful exchanges. In recent congresses, from

Fepal as well in those organized by the European Federation, and the North American institutions, there are invited members from the other two regions, which indicates a growing interchange. Fepal holds its administrative meetings regularly, publishes its *Revista Latino-Americana de Psicanálise* (Latin American Journal of Psychoanalysis), and has an ongoing scientific program of exchanges among its component societies. In spite of difficult social and economic conditions in most countries of Latin America, psychoanalysts and candidates affiliated to FEPAL keep a continuous and passionate interest and commitment with psychoanalysis and contribute to its development both as a theory and a clinical practice.

In the next IPA Congress to be held in Rio de Janeiro, in July, 2005, the first one in Brazil, the second Latin American will become the IPA president, Cláudio Laks Eizirik, following the pioneer role of Horacio Etchegoyen, in 1993.

Beyond these activities, another dimension should be taken into account: FePAL provides a forum for meetings and joint reflection on psychoanalytic theory and clinical practice in the specific context of the particular cultures of the countries it represents and within the framework of a broader Latin American identity, with all the challenges currently posed by that condition.

CLÁUDIO LAKS EIZIRIK

### **Bibliography**

- Eizirik, Cláudio Laks. (1998). *Porqué Fe.P.A.L.? Boletín informativo de la Fe.P.A.L.* (2nd semester).
- Sanchez-Medina, Guillermo. (1998). *Sesenta años de psicoanálisis en Latinoamérica. Homepage Federación psicoanalítica de América latina.*

---

### **FEDERN, PAUL (1871–1950)**

Paul Federn, an Austrian physician and psychoanalyst, was born in Vienna on October 13, 1871, and died in New York on May 4, 1950.

The son of a famous Viennese doctor and nephew of a celebrated Prague rabbi, Federn was raised in a family with a longstanding liberal tradition. After receiving his medical diploma in 1895, he interned in general medicine with Hermann Nothnagel, who introduced him to the works of Sigmund Freud.

Deeply influenced by Freud's *Interpretation of Dreams*, in 1904 he devoted himself to psychoanalysis and, with Alfred Adler, Wilhelm Stekel, and Rudolf Reitler, became one of Freud's early disciples.

Federn was as interested in the analysis of social phenomena as he was in prevention and treatment of disease. In *Zur Psychologie der Revolution: die Vaterlose Gesellschaft* (On the psychology of revolution: the fatherless society; 1919), he analyzed the challenge to authority by the postwar generation as unconscious parricide aimed at creating a "fatherless society." In line with his interest in applying psychoanalysis to public health, in 1926 he published, together with Heinrich Meng, *Das psychoanalytische Volksbuch* (Popular psychoanalysis).

Of the Viennese disciples, Federn worked longest with Freud and was highly esteemed by him. He was such a loyal supporter of Freud that he was referred to as the "Apostle Paul" of the psychoanalytic movement. His position within the Psychoanalytic Society continued to grow over the years. In 1922 he helped Eduard Hitschmann and Helene Deutsch establish the Vienna Ambulatorium, and during the 1930s he was one of the coeditors of the *Internationale Zeitschrift für Psychoanalyse* and editor of *Zeitschrift für Psychoanalyse und Pädagogik*. But the most important source of official recognition came from Freud himself, who, in 1924, made him, along with Anna Freud, his official representative and vice president of the Vienna Society, a position he held until 1938.

After emigrating to America in 1938, Federn settled in New York. Though he got recognition for his medical diploma (which he received before 1914), it was not until 1946 that he was officially recognized as a training analyst at the New York Psychoanalytic Institute. He committed suicide after the recurrence of what he felt was an incurable cancer.

In addition to ego psychology, Federn was interested in the therapy of psychosis. Even his earliest writings, devoted to the sources of sadism and masochism and typical dream sensations (1914), manifest his interest in the nature and function of the ego, along with considerations of narcissism.

The results of Federn's research took time to come to fruition, since his ideas about the ego required a long period of gestation. In 1926 his important essay "Some Variations in Ego-Feeling" appeared, followed in 1928 by "Narcissism in the Structure of the Ego,"

and in 1929 by "Das Ich als Subjekt und Objekt im Narzissmus" (The ego as subject and object in narcissism). His phenomenological description of the ego as experience coinciding with "ego feeling" diverged considerably from Freud's structural approach. Although his conclusions were far removed from Freud's, out of loyalty Federn preferred to downplay his own theoretical contributions, such as "ego feeling," the "sense of reality," the "limits" and "states" of the ego, "ego cathexis," the "median" nature of narcissism, and the death drive. For although Freud had a great deal of respect for Federn, he did not value Federn's theoretical proposals very highly.

In his studies of schizophrenic patients, Federn came to the conclusion that, far from being excessively cathected with libido, their egos possessed inadequate cathectic energy. On Federn's hypothesis, contrary to the hypotheses of Freud and Karl Abraham, it was an absence rather than an excess of narcissistic libido that determined the psychotic's problems with the object. As a result, Federn's approach to treating psychotics, described in "The Analysis of Psychotics" (1934) and other important texts he wrote while in America, involved supporting the patient's efforts at integration by trying to prevent the emergence of the repressed and by strengthening the patient's defenses. According to Federn, transference in psychosis should not be interpreted. He felt that it was important to avoid negative transference and to help the psychotic confront problems by means of female support figures.

Although the response to Federn's ego psychology was limited, he had several illustrious followers, including Edoardo Weiss and Hermann Nunberg, along with a small group of American analysts such as Bertram D. Lewin, I. Peter Glauber, and Martin Bergmann. In psychiatry the influence of his ideas is obvious. His ideas also served as a foundation for the transactional analysis of Eric Berne, who refers to the theory of "ego states." Weiss was responsible for the posthumous publication of Federn's writings, *Ego Psychology and the Psychoses* (1952), a book that contributed greatly to spreading the ideas of one of the earliest and most faithful pioneers of psychoanalysis.

ANNA MARIA ACCERBONI

*Work discussed:* *Ego Psychology and the Psychoses*.

*Notions developed:* Ego boundaries; Ego, damage inflicted on the; Ego feeling; Ego stages.

See also: Ego (ego psychology); Lehrinstitut der Wiener psychoanalytischen Vereinigung; Marxism and psychoanalysis; Wiener psychoanalytischen Vereinigung.

### Bibliography

- Federn, Ernst. (1972). Thirty-five years with Freud. *Journal of Clinical Psychology*, suppl. 32, 18–34.
- Federn, Paul. (1914). On dreams of flying. In Hendrik M. Ruitenbeek (Ed.), *The first freudians* (pp. 121–128). New York: Jason Aronson.
- . (1919). Zur psychologie der revolution: die vaterlose gesellschaft. Vienna: Anzengruber-Verlag.
- . (1926). Some variations in ego-feeling. *International Journal of Psycho-Analysis*, 7, 434–444.
- . (1928). Narcissism in the structure of the ego. *International Journal of Psycho-Analysis*, 9, 401–419.
- . (1934). The analysis of psychotics. *International Journal of Psycho-Analysis*, 15, 209–214.
- . (1952). *Ego-psychology and the psychoses* (Edoardo Weiss, Ed.). New York: Basic Books.
- Federn, Paul, and Meng, Heinrich. (1926). *Das psychoanalytische volksbuch* (2 vols.). Stuttgart: Hippocrates.
- Pao, Ping-Nie. (1975). The place of Federn's ego psychology in a contemporary theory of schizophrenia. *International Review of Psychoanalysis*, 2, 467–480.
- Weiss, Edoardo. (1951). Paul Federn's scientific contributions: in commemoration. *International Journal of Psycho-Analysis*, 32 (4), 1–8.
- . (1966). Paul Federn: The theory of the psychoses. In Franz Alexander, Samuel Eisenstein, and Martin Grotjahn (Eds.), *Psychoanalytic pioneers* (pp. 142–159). New York: Basic Books.

## FÉDIDA, PIERRE (1934–2002)

The French psychoanalyst Pierre Fédida was born in Lyon, France, on October 30, 1934, and died in Paris on November 1, 2002. He was a full member and president of the Association psychanalytique de France (French Psychoanalytic Association), a member of the International Psychoanalytical Association, and cofounder, with Daniel Widlöcher, of the *Revue Internationale de psychopathologie* (International journal of psychopathology).

He passed the *concours d'agrégation*, a prestigious teacher-qualifying exam, in philosophy, and in 1962 he was appointed to a university-level teaching position.

He began his clinical training in psychiatry and neuropsychiatry at the age of twenty-three, notably at the Bellevue Sanatorium in Kreuzlingen, Switzerland, with Professor Ludwig Biswanger and in Münsterlingen, Switzerland, with Professor Roland Kuhn. His thinking on the treatment of psychotics was thus stamped with a distinctive phenomenological orientation that remained with him throughout his career.

All his psychoanalytic training (both individual analysis and professional training) took place under the Association psychanalytique de France, where he enrolled as a student in the 1960s and entered into analysis with Georges Favez. Although his background in phenomenological philosophy initially concerned some, he quickly established himself in the eyes of professionals as a very astute clinician with an exceptional mastery of the theory of treatment. After he became a training analyst, he was elected president of the Association psychanalytique de France in 1988 and undertook significant statutory reforms. Notably, he expanded the cadre of training analysts to include all tenured members of the association. He then played an active role in the European Federation of Psychoanalysis and the International Psychoanalytical Association, where, from 2000, he was responsible for contacts with psychologists, psychiatrists, and other psychoanalytic schools throughout Europe.

Concurrent with these developments, in 1966 he became senior assistant in clinical psychology at the Sorbonne with Juliette Favez-Boutonier. This led to his participation in the events that revolutionized the French university system in May 1968, with Jean Laplanche and others soon joining in.

Fédida taught at the Université de Paris VII from 1969 to 2002, and at the university he founded the Laboratoire de psychopathologie fondamentale et psychanalyse (Laboratory of basic psychopathology and psychoanalysis). Within the university's research and training program in human clinical sciences, which he helped establish, he served in many scientific and administrative capacities, including that of program director.

From the outset he brought a perspective transcending disciplines to his teaching, aiming to critique and bring together the main approaches in psychopathology, whether phenomenological, biological, or psychoanalytic. This open approach led him to establish a research laboratory in 1989 and an advanced degree program in basic psychopathology in 1990,

which he wanted to link with biology and then to the Centre d'études du vivant (Life studies center) at the Université de Paris VII (where he also served as vice president from 1987 to 1989). He also traveled widely to universities abroad, where he established a solid network of relationships, especially in Brazil and other Latin American countries.

Fédida wrote a substantial number of works: 320 publications on a wide variety of subjects. In addition to ten to twelve articles each year from 1962, he penned such major works as *Corps du Vide et Espace de Séance* (The body of the void and the space of the session; 1977); *L'Absence* (Absence; 1978), *Crise et Contre-Transfert* (Crisis and counter-transference; 1992), *Le Site de L'Étranger* (The site of the alien; 1995), and *Les Bienfaits de la Dépression* (The benefits of depression; 2001). These works have been translated into many languages. Unifying themes of his work are the concealed, the stranger within, and enigmatic knowledge of the self.

A man of dialogue conscious of his own charisma, Fédida fashioned an atypical discourse combining psychoanalysis, psychopathology, philosophy, literature, architecture, and art history. His writings present a complex blend of scientific rigor, human openness, and confidence in diversity.

SOPHIE DE MIJOLLA-MELLOR

*See also:* Association psychanalytique de France; Counter-transference; Favez-Boutonier, Juliette; Groddeck, Georg Walther; Intergenerational.

### **Bibliography**

- Fédida, Pierre. (1977). *Corps du vide et espace de séance*. Paris: J.-P. Delarge.
- . (1978). *L'absence*. Paris: Gallimard.
- . (1992). *Crise et contre-transfert*. Paris: Presses Universitaires de France.
- . (1995). *Le site de l'étranger*. Paris: Presses Universitaires de France.
- . (2000). *Par où commence le corps humain: Retour sur la régression*. Paris: Presses Universitaires de France.
- . (2001). *Des bienfaits de la dépression: Éloge de la psychothérapie*. Paris: Odile Jacob.
- Fédida, Pierre, and Guyotat, Jean (Eds.). (1986). *Mémoires et transferts*. Paris: Écho-Centurion.

**FEES.** *See* Money and psychoanalytic treatment

## **FEMALE SEXUALITY**

Freud's observations on female sexuality were made between 1923 and 1933, late in his career. They cannot be understood without reference to his thesis of the primacy of the phallus, according to which, for both sexes, "only one genital"—the male one—played a structuring role (1923e, p. 142). Structurally speaking, the phallic phase defined the girl as much as the boy, but the girl's embrace of the phallic—at once real (experienced directly), imaginary (fantasized in an oscillation between power and impotence), and symbolic (thought-cathexis)—was centered on the clitoris. Even though the Freudian theorization of the girl's psychosexual development toward femininity took as its sole basis the psychosexuality of the boy, Freud continually emphasized the differences between the sexes in this regard, and hence too the specificity of the female Oedipus complex.

Penis envy and the castration complex play the major, organizing roles that made access to femininity possible. As Freud wrote in "Some Psychological Consequences of the Anatomical Distinction between the Sexes," little girls "notice the penis of a brother or playmate, strikingly visible and of large proportions, at once recognize it as the superior counterpart of their own small and inconspicuous organ, and from that time forward fall a victim to envy for the penis" (1925j, p. 252). This injury, at once phallic and narcissistic, was experienced to begin with as a personal punishment, then accepted as part of a broader truth: women do not have them. That the mother should have omitted to "give her a proper penis" (1931b, p. 234) constituted the main motive, specific to the little girl, for transferring her affections to the father. This reversal was more a flight from the mother than a choice of the father as object. It was this disillusionment, coupled with the depreciation of the mother contingent upon the discovery that she was castrated, that occasioned the abandonment of the relationship with the mother as object.

The renunciation of phallic activity (clitoral masturbation) allowed passivity to come to the fore: "The transition to the father-object is accomplished with the

help of the passive trends in so far as they have survived the catastrophe. The path to the development of femininity now lies open to the girl" (p. 239). The girl placed all her hopes on her father, waiting for him to give her the penis that her mother had "refused" her. The feminine attitude would be reached only if an equivalence was established between penis and child and the wish for a penis transformed into the wish for a child.

What Freud had discovered in 1931 was that for the little girl the mother as dispenser of the earliest bodily care is the object of a particularly intense and long-lasting archaic cathexis. He compared this first bond between mother and daughter to the Minoan-Mycenaean civilization so long obscured from view by the civilization of Athens: "Our insight into this early, pre-Oedipus, phase in girls comes to us as a surprise, like the discovery, in another field, of the Minoan-Mycenaean civilization behind the civilization of Greece" (p. 226). He immediately pointed up the ambivalence of this earliest bond: primary homosexuality, the idea of which was to be further developed by Freud's successors, was built upon the amorous or tender current in mother-infant coexcitation, which was nevertheless not devoid of aggressiveness. Attachment and hostility toward the mother were differently inflected depending on whether they related to the oral or the anal phase. During the oral phase, after the withdrawal of the breast, they arose in response to the little girl's fears of being devoured, poisoned or killed by her mother. During the anal phase, the pleasure associated with various maternal manipulations was related to the intrusive anal mother (described by Ruth Mack Brunswick as arousing the girl's aggressiveness).

His discovery of a primal coexcitation sensorily uniting daughter and mother, and of the dramatic rift that ensued between the two female members of this initial dyad, supplied Freud with much support for his conclusion that the mental bisexuality of women was more marked than that of men. The subsequent route to femininity was a long one, marked by the detachment from the pre-oedipal mother and calling for both a change in the erogenous zone cathected (the shift from clitoris to vagina), and a change of object. Taking the father as love-object is thus seen as a second phase in the little girl's mental development, so that it is possible to speak of a two-phase oedipal period for women (Jeanne Lampl-de Groot, Julia Kristeva). Freud went so far as to say that he saw no dissolution of the

Oedipus complex in the female. Whereas in the boy the complex succumbed to the threat of castration, it would have no end in the case of women and would manifest itself as such in both the need for motherhood and in the character of "females as social beings" (p. 230). In addition to the path leading to the choice of the father as object, Freud evoked two other possible routes: the young woman might turn away from sexuality into neurosis (inhibition), or she might refuse to renounce the phallus and develop a masculinity complex.

Freud's phallogocentric account, which he took up again in the *New Introductory Lectures on Psycho-Analysis* (1933a [1932]), has been widely criticized. In the first place, a number of psychoanalysts, among them Karen Horney, Ernest Jones, Melanie Klein, and Helene Deutsch, have in particular contested the claim that penis envy is a primary given rather than a construction developed or used in a secondary way in response to primitive wishes. At the same time feminists have castigated Freud for incorporating his own phallogocentric and bourgeois prejudices into his theory. But it must not be forgotten that Freud's theorizing here addresses the Unconscious, so that only criticisms doing likewise have relevance (André, 1994). Furthermore it is essential to bear in mind that according to Freud the phallic organization in fantasy is based on the "infantile" genital organization, and that the primacy of the phallus, for the girl as for the boy, is deemed an aspect of the child's development and can in no way be conflated with the adult genital organization. Last, and most important, the idea of phallic primacy must be understood as the primacy of a symbolic dimension, not an organic one. In his *Écrits* (1966), Jacques Lacan describes the dynamics of a human psyche, dependent on language, which necessarily embraces both the male and the female speaking subject. Even though the "detachability" of the penis inevitably makes it the "signifier of the lack," and hence the symbol of the signifying function itself, men and women nevertheless relate to it differently. Recent psychoanalytical research has paid particular attention to the exploration of this difference, and notably to the "strangeness of the phallus" for the female (Kristeva).

JULIA KRISTEVA

*See also:* Feminine masochism; Femininity; Femininity, rejection of; Feminism and psychoanalysis; Gender identity; Infantile sexual curiosity; Masculinity/femininity; Oedipus complex; Penis envy; Phallic woman; Psy-

chosexual development; Sexual differences; Sexuality; Sexualization; Wish for a baby.

### **Bibliography**

- André, Jacques. (1994). *Sur la sexualité féminine*. Paris, Presses Universitaires de France.
- Freud, Sigmund. (1923e). The infantile genital organization. *SE*, 19: 141–145.
- . (1925j). Some psychical consequences of the anatomical distinction between the sexes. *SE*, 19: 241–258.
- . (1931b). Female sexuality. *SE*, 21: 221–243.
- . (1933a [1932]). New introductory lectures on psycho-analysis. *SE*, 22: 1–182.
- Kristeva, Julia. (2000). *The sense and non-sense of revolt* (Jeanine Herman, Trans.). New York: Columbia University Press, 2000. (Original work published 1996)
- Lacan, Jacques. (1966). *Ecrits*. Paris: Seuil.

### **Further Reading**

- Chodorow, Nancy. (1994). *Femininities, masculinities, sexualities. Freud and beyond*. Lexington, KY: University Press of Kentucky.
- Deutsch, Helene. (1946). *The psychology of women: I. Girlhood. II. Motherhood*. London: Research Books Ltd.
- Gilmore, Karen. (1998). Cloacal anxiety in female development. *Journal of the American Psychoanalytic Association*, 46, 443–470.
- Horney, Karen. (1973). *Feminine psychology*. New York: W. W. Norton.
- Kleeman, James A. (1976). Freud's view on early female sexuality in the light of direct child observations. *Journal of the American Psychoanalytic Association*, 24, 3–28.
- Silverman, Doris K. (2003). Theorizing in the shadow of Foucault: Facets of female sexuality. *Psychoanalytic Dialogues*, 13, 243–258.

## **FEMININE MASOCHISM**

Feminine masochism, “an expression of the feminine being nature” (p. 161), is one of the three forms of masochism described by Sigmund Freud in “The Economic Problem of Masochism” (1924c), along with moral masochism and primary, erotogenic masochism. Based “entirely . . . on the primary, erotogenic masochism” (p. 162), feminine masochism, according to Freud, is clinically accessible through the fantasies

of masochistic men, who obtain sexual satisfaction primarily through masturbation. Behind such men's need for punishment and humiliation (which form a transition with moral masochism by way of guilt) there is an infantile staging of a “characteristically female situation” that signifies “being castrated, or copulated with, or giving birth to a baby” (p. 162).

In Freud's view, the passivity of masochism is linked to femininity, and the active nature of sadism to virility, as he wrote in *New Introductory Lectures on Psycho-Analysis* (1933a [1932]). He first described this connection between active/passive and masculine/feminine in *Three Essays on the Theory of Sexuality* (1905d). However, in 1933, taking bisexuality into consideration, he relativized this opposition and stressed the role of the instinctual aim: “to achieve a passive aim may call for a large amount of activity” (p. 115). He also acknowledged that the social repression of aggressiveness in women could lead to secondary masochistic impulses, “which succeed . . . in binding erotically the destructive trends which have been diverted inwards” (p. 116).

Freud's discomfort on the issue of woman's sexuality is apparent in his description of feminine masochism in men, even though his 1924 essay rehabilitates masochism as a form of protection in the individual against the death instinct and as a factor in the organization of the ego. Yet we can deduce from his thinking that he thought that a woman's intimate acquaintance with passivity, and thus her capacity for masochism, also play a part in her strength, and not just in her weakness stemming from her need for love. Masochism is part of the intensity of her sexual pleasure, but also of the strength of her love as a woman and mother.

See also: Masochism

DENYS RIBAS

### **Bibliography**

- Freud, Sigmund. (1905d). Three essays on the theory of sexuality. *SE*, 7: 123–243.
- . (1924c). The economic problem of masochism. *SE*, 19: 155–170.
- . (1933a [1932]). New introductory lectures on psycho-analysis. *SE*, 22: 1–182.

### **Further Reading**

- Bernstein, Isidore. (1983). Masochistic pathology and feminine development. *Journal of the American Psychoanalytic Association*, 31, 467–486.

Blum, Harold P. (1976). Masochism, the ego ideal, and the psychology of women. *Journal of the American Psychoanalytic Association*, 24, 157–192.

Bonaparte, Marie. (1935). Passivity, masochism and femininity. *International Journal of Psychoanalysis*, 16, 325–333.

Deutsch, Helene. (1930). The significance of masochism in the mental life of women. *International Journal of Psychoanalysis*, 11, 48–60.

Horney, Karen. (1935). The problem of feminine masochism. *Psychoanalytic Review*, 22, 241–257.

## FEMININITY

Freud refused to put forward a definition of femininity: “In conformity with its peculiar nature, psychoanalysis does not try to describe what a woman is . . . but sets about enquiring how she comes into being” (1933a [1932], p. 116). He posits a primary bisexuality as the starting point for this process.

In Freud’s view, the genesis of femininity differs from the genesis of masculinity because its linearity is interrupted. In the pre-oedipal phase, the girl’s libido, instead of taking the opposite-sex parent as its object, as the boy does, is directed at the mother as object. This period is difficult to investigate because of the “inexorable repression” (1931b, p. 226) that overshadows it.

Therefore, the development of girls’ sexuality is studied in an indirect way based on the process that the boy undergoes. In the early stages a similar path is traced: “the little girl is a little man” (1933a, p. 118), with the clitoris being interpreted in the phallic phase as a miniature penis. Then there are two shifts in perspective, shifts in which there is an explicit moral imperative. The girl has the duty of turning from the mother to the father (1939a [1934–1938]): the zone of sensitivity moves from the clitoris to the vagina, and there is a change of object to the father.

Reconversion is made possible by the differential impact of the castration complex on boys and girls. In boys, the castration complex puts an end to the Oedipus complex. But for girls, the castration complex makes the Oedipus complex possible.

The girl sees her mother as castrated, while her love is “directed to her *phallic* mother” (1939a, p. 126). This gives rise to a penis envy that later radiates beyond the desired object to imbue the woman’s psychic life with envy and jealousy. The girl then chooses

the father as object because he possesses the envied organ, and this new libidinal orientation is superimposed on the orientation of the mother as object, without replacing it entirely. The woman often transfers her early relationship with her mother onto her male partner. The need to anticipate from someone else what the woman once wanted to possess herself makes her dependent in a way that leads both to masochism (with the castigation she receives relating to her position in coitus) and to narcissism (which is expressed in her greater need to be loved than to love). Presenting another perspective in “On Narcissism: An Introduction” (1914c), Freud stated that following puberty, women, “especially if they grow up with good looks, develop a certain self-contentment” that exercises “a great attraction for those who have renounced part of their own narcissism” (p. 89).

Although the texts that present a synthetic view of femininity are focused on lack, Freud’s incursions into mythology and literature emphasize something beyond the phallic stage in girls. This something is a place in the female body characterized by its internal nature (the “jewel-case”) or by disorientation, as in the sense of the uncanny. The woman then appears not as an externally definable form but as a “hollow space” (1916–1917a [1915–1917], p. 156) that can receive what penetrates it. The spatial disorientation is coupled with a temporal disorientation, in which the representation of femininity becomes confused with the notion of birth linked with the fear of death, as if the third of the Fates had come to embody a femininity that governed all of destiny. Freud’s study of femininity thus diverges into a theoretical synthesis derived from phallic logic and a representation of femininity that mythologizes woman as a place—whether of birth or death—where the processes of life are played out for every human being.

The idea of taking a foreign element into the self appears as the crossroads where the representations of psychoanalysis intersect with those of female sexuality. When Freud noted how the transference configuration enabled a repressed element to be taken in, he usually gave an example—Elisabeth in *Studies on Hysteria* (1895d) or Irma with her dream about the injection—of a patient struggling against accepting a proposed solution or repressed representation (1900a). Recourse to these terms had a clear impact on the paper “Negation” (1925h), because acceptance into the ego enabled repression to be effectively lifted.



Freud noted the conjunction between such acceptance and the outcome of female sexuality in “On the Sexual Theories of Children” (1908c), where he referred, in connection with the mother representation, to the discovery of the “cavity which receives the penis” (p. 218). In the moment of affirmation associated with the lifting of repression, the psychic apparatus has to receive the repressed element just as the female “hollow space” has to receive the penis. This correlation reappears in “Analysis Terminable and Interminable” (1937c), where Freud describes the man’s refusal to accept the cure from the psychoanalyst as his rejection of femininity. Does a refusal of this kind arise from the fear of losing masculinity or the fear of invasion occasioned by opening the self as a “hollow space”? Two different definitions of femininity clash at this juncture.

Post-Freudian psychoanalysis both extended and revised Freud’s lines of approach to femininity. The phallic primacy attributed to both sexes became a matter of dispute. Karen Horney asserted that the girl discovers vaginal sensations early on. As a result, recourse to the penis takes on a defensive significance. Ernest Jones did not consider woman as a form of failed man, and he related female anxiety not to castration anxiety but to aphanisis anxiety, the fear of losing her internal sensitivity. Janine Chasseguet-Smirgel challenged the passive concept of the vagina. She saw the vaginal aim of incorporation as conferring a capacity for mastery, as with anality.

Conrad Stein sought to define a specifically feminine outcome by positing “castration as a negation of femininity.” He argued that insofar as masculinity carries a “symbolic representation of itself,” it is a guardian of identity. In contrast, the female pole, situated close to being, is governed by a tendency toward “destruction of the self’s identity,” which, when it gives rise to anxiety, “is negated by the act of regarding woman only as a castrated being.” The risk of destruction to which the woman is exposed leads to a focus in the analysis on the dimension of invasion (André; Schaeffer).

Is there a fundamental difference between masculine protest and feminine protest organized around a receptive hollow space? In accordance with some of Michèle Montrelay’s theories, François Perrier emphasized the girl’s relationship with her mother, in which her fantasy involvement does not involve risking a part of herself but diving in head first. To reduce the risk of

being sucked in, the girl appeals to the male organ, on which she confers investigative properties. Penis envy is thus governed not by rejection of femininity but by the girl’s desire to orient herself in this space.

Wladimir Granoff examined the tendency for theory to construct femininity in negative terms. He regards femininity as a defense that resembles the child’s decision to prefer the father to the mother. In this view, thought needs to turn away from femininity to construct an intellectualized universe. This turning away resembles the son-in-law’s prohibition against turning toward his mother-in-law in Freud’s analysis and is related to Freud’s invitation to explore, beyond classical Greek culture, cultures that have been repressed by “turning from the mother to the father” (1939a, p. 114).

Because the female genital opening is feared as a place of absence, pubic hair has been ascribed the function of a veil, though it can equally well belong to fantasies surrounding fertility and growth, reminiscent of Demeter (Schneider). Marcel Detienne’s observation concerning the dual character of the founding sites of Greek culture—“Eleusis is the counterpart of Athens”—can be used to inform the study of femininity. Freud’s *Moses and Monotheism* (1939a [1934–1938]), drawing on Aeschylus’s *Eumenides*, belongs in the mythical tradition that began with the founding of Athens. Accordingly, it pays tribute to Athena, a virgin born without a mother. It might well be appropriate to unearth those underworld entities that Athena proposes at the end of the tragedy, to lead “Into the earth/ The cavern timeless as the tomb.”

MONIQUE SCHNEIDER

*See also:* Activity/passivity; Castration complex; Dark continent; Female sexuality; Feminine masochism; Femininity, rejection of; Feminism and psychoanalysis; Gender identity; Masculinity/femininity; *New Introductory Lectures on Psychoanalysis*; Object, change of/choice of; Penis envy; *Psychology of Women. A Psychoanalytic Interpretation, The*; Sexual differences; “Some Psychical Consequences of the Anatomical Distinction between the Sexes.”

### Bibliography

- André, Jacques. (1995). *Sur la sexualité féminine*. Paris: Presses Universitaires de France.
- Chasseguet-Smirgel, Janine. (1970). Feminine guilt and the Oedipus complex. In her *Female sexuality* (pp. 94–134).

- Ann Arbor: University of Michigan Press. (Originally published 1964)
- Freud, Sigmund. (1900a). The interpretation of dreams. *SE*, 4: 1–338; 5: 339–625.
- . (1908c). On the sexual theories of children. *SE*, 9: 205–226.
- . (1914c). On narcissism: an introduction. *SE*, 14: 67–102.
- . (1916–1917a [1915–1917]). Introductory lectures on psycho-analysis. *SE*, 15–16.
- . (1925h). Negation. *SE*, 19: 233–239.
- . (1931b). Female sexuality. *SE*, 21: 221–243.
- . (1933a [1932]). New introductory lectures on psycho-analysis. *SE*, 22: 1–182.
- . (1937c). Analysis terminable and interminable. *SE*, 23: 209–253.
- . (1939a [1934–1938]). Moses and monotheism: Three essays. *SE*, 23: 1–137.
- Freud Sigmund, and Breuer, Josef. (1895d). Studies on hysteria. *SE*, 2: 48–106.
- Granoff, Wladimir. (1976). *La pensée et le féminin*. Paris: Minuit.
- Horney, Karen. (1967). *Feminine psychology*. New York: W. W. Norton.
- Jones, Ernest. (1950). Early development of female sexuality. In his *Papers on psycho-analysis*. London: Bailliere, Tindall and Cox.
- Montrelay, Michèle. (1978). Inquiry into femininity. *M/F*, 1, 83–102.
- Schaeffer, Jacqueline. (1997). *Le refus du féminin*. Paris: Presses Universitaires de France.
- Schneider, Monique. (1992). *La part de l'ombre: Approche d'un trauma féminin*. Paris: Aubier.
- Stein, Conrad. (1977). La castration comme négation de la féminité. In his *La mort d'Edipe* (pp. 155–183). Paris: Denoël.
- Richards, Arlene K. (1996). Primary femininity and female genital anxiety. *Journal of the American Psychoanalytic Association*, 44(S), 261–282.
- Stoller, Robert J. (1976). Primary femininity. *Journal of the American Psychoanalytic Association*, 24, 59–78.

## FEMININITY, REJECTION OF

Rejection of femininity refers to a man's rejection of the feminine elements inherent in his constitutional bisexuality.

The concept first appeared in Freud's article "Analysis Terminable and Interminable" (1937c), where he introduced it in his discussion of the "bedrock" beyond which analytic work cannot continue. It also formed a part of his ongoing argument against the term proposed by Alfred Adler, "masculine protest." This bedrock, which takes the form of penis envy in women, appears in men as a rejection of femininity. Specifically, what the man rejects is a passive position towards another man.

The question of the exact nature of this rejected femininity is taken up again when Freud specifies what it is that the man is defending himself against: "He refuses to subject himself to a father-substitute . . . and consequently he refuses to accept his recovery from the doctor" (1937c, p. 252). The notion of "acceptance" (*Annahme*) is related to femininity, but without reference to the phallic organization. It refers to the act by which the vagina, as "cavity," "receives the penis" (1908c, p. 218).

Thus the rejection of femininity might be viewed as the refusal of inner space (as representative of mental space as a whole) to admit a foreign body. Jacqueline Schaeffer (1997) has spoken in this connection of anxiety about a femininity perceived as the "penetration of the ego and the body by a stranger, the agent of an incursion that feeds the constant pressure of the drive."

MONIQUE SCHNEIDER

See also: Femininity.

### Bibliography

- Freud, Sigmund. (1937c). Analysis terminable and interminable. *SE*, 23: 209–253.
- . (1908c). On the sexual theories of children. *SE*, 9: 205–226.

### Further Reading

- Dahl, Kirsten. (2002). In her mother's voice: reflections on femininity and the superego. *Psychoanalytic Study of the Child*, 57, 3–26.
- Kulish, Nancy. (2000). Primary femininity: Clinical advances and theoretical ambiguities. *Journal of the American Psychoanalytic Association*, 48, 1355–1380.

Schaeffer, Jacqueline. (1997). *Le refus du féminine*. Paris: Presses Universitaires de France.

Schneider, Monique. (1992). *La part de l'ombre. Approche d'un trauma féminin*. Paris: Aubier.

## FEMINISM AND PSYCHOANALYSIS

Freud's discovery of the unconscious is centrally linked to the study of female sexuality. In listening to the hysterics, Freud gave them a voice and attributed a meaning to what they said. As Juliet Mitchell noted, feminist movements have tended to equate what Freud said about the hysterics and his other female patients as prescriptions for patriarchal domination of women rather than understanding his writings as an analysis of women's position in patriarchal societies.

Feminist movements, especially in the 1960s and 1970s, were hostile to psychoanalysis, as they viewed it as a major factor in the oppression of women. The issues that feminists challenged in psychoanalysis centered on Freud's formulations of the differentiation between the sexes, in terms of the association of masculinity with activity and femininity with passivity; Freud's emphasis on the existence of penis envy in women; female masochism; and the emphasis on the role of the father as opposed to feminists' reassessment of the mother-daughter relationship.

Simone de Beauvoir's *La deuxième sexe* (1949) and Betty Friedan's *The Feminine Mystique* (1963) both viewed psychoanalysis as regarding women as inferior and as defining them only with reference to men. Then in the 1970s another wave of feminist writings, such as Kate Millet's *Sexual Politics* (1970), Shulamith Firestone's *The Dialectic of Sex: The Case for Feminist Revolution* (1970) and Germaine Greer's *The Female Eunuch* (1970), called for changes in society that would help to eliminate sexual inequality. Mitchell's *Psychoanalysis and Feminism* (1972) was a marker in the recovery of psychoanalysis, by explaining its revolutionary understanding of women.

From a very early stage, psychoanalysis maintained that the psychic reality of sex had to be distinguished from the anatomical reality, that there was no one-to-one correlation between biology and psychology. Men and women are not physically or socially "made" as male or female but become such.

Initially, however, Freud assumed a symmetry in the development of what he called the Oedipus

complex. It was only in an essay written in 1925 that Freud distinguished between the psychosexual history of boys and girls and recognized the importance of the pre-oedipal phase in which boys and girls love the mother, and both have to relinquish her in favor of the father (1925j). The girl has to move from loving her mother to loving her father, whereas the boy gives up his mother with the understanding that he will later have a woman of his own. In this model, boys identify with their fathers as their masculine identity is established. The little boy learns his role as the heir of his father. The little girl, on the other hand, has to identify with her mother while at the same time abandoning her as a love object and turning to her father instead. For Freud this turning away from the mother is based on frustration and the disappointment that she cannot satisfy her mother, and is accompanied by hostility.

The importance of the "pre-oedipal" relationship with the mother has been more fully discussed since Freud's time. More recently interest in the nature of female identity can be found in the works of Ethel Person, Irene Fast, and Jessica Benjamin in the United States, as well as in the works of Janine Chasseguet-Smirgel, Catherine J. Luquet-Parat, Maria Torok, and Joyce McDougall in France.

In the 1920s a controversy took place over the perception of femininity. If for Freud libido is identical in the two sexes, for the English School, feminine libido is specific. Karen Horney and Ernest Jones participated in a series of interchanges and opposed Freud's views by putting forward a "positive" view of female sexuality, not linked to an idea of a lack. For Jones, femininity's development is linked to instinctual constitution. In debate with him, Freud asserted that Jones profoundly misunderstood the fundamental nature of sexuality and that Jones had returned to a biological reductionism. Mitchell has pointed out that the Freud-Jones controversy shifted from the question of what distinguished the sexes to what each sex has that is specific to it alone.

Developments in psychoanalytic theory in England, with the school of object relations, led to an emphasis on the mother-child dyad, and on motherhood. Psychoanalytic work from an early stage concentrated on primitive states in infancy, and progressively attention was paid to the impact of these primitive states on transference. Melanie Klein's theory carried on Freud's shift in the emphasis from the father to the mother and the mother's importance for children of both

sexes. For her, the relationship of the child to the mother's body shaped subsequent emotional life. Particularly, the relationship to the breast is crucial in the child's early experiences. Klein's concepts of introjective and projective identification are metaphors for the bodily processes of taking in and expelling. According to Klein, the little girl believes her mother's body contains everything that is desirable, including the father's penis. As a consequence the little girl is filled with hatred towards her mother and wishes to attack and rob the inside of her body. She is then filled with a persecutory anxiety of "having the inside of her body robbed and destroyed." In 1928 Klein argued that it was the deprivation of the breast rather than the discovery of the lack of penis that turned the little girl away from the mother towards the father. Later she downplayed the child's original envy of the breast and wrote about an essentially heterosexual drive in little girls. Klein's views on this early relationship between mother and baby had an impact on some of the early writings on femininity in the British society, such as the work of Joan Riviere and Sylvia Payne.

Progressively psychoanalysts from all the groups in the British Society, inspired by the works of Klein, Donald Winnicott, Marjorie Brierly and Wilfred Bion, have emphasised the connection between primary affective development and object relations. One can trace these themes throughout the writings of Marion Burgner and Rose Edcumbe, Egle Laufer, Dinora Pines, Dana Breen, Joan Raphael-Leff, and Rosine Perelberg. In a more recent collection presenting work of the three schools of psychoanalysis in the British Psycho-Analytical Society, Raphael-Leff and Perelberg stress the primitive tie to the mother and its manifestations in transference and countertransference.

American feminists have perceived psychoanalysis as reproducing patriarchal inequalities. Nancy Chodorow is one of the most well-known writers in the United States on the relationship between psychoanalysis and feminism. *The Reproduction of Mothering: Psychoanalysis and the Sociology of Gender* (1978) introduced the work of Winnicott, W. Ronald Fairbairn, and Harry Guntrip to American readers. Chodorow emphasizes the development of the self in relation to others, stressing the pre-oedipal relationship between mother and child. She views the function of mothering as creating an asymmetrical relationship between boys and girls. The girl has more permeable boundaries in the relationship with the other because

of having been mothered by someone of the same gender. Girls are themselves, therefore, more committed to mothering. Boys, in contrast, develop a sense of self in opposition to the mother and establish more rigid boundaries. The masculine sense of self is more separate.

Jean Baker Miller and Carol Gilligan, from the interpersonal school of analysis, emphasize women's attributes of relatedness, empathy and nurturance which are viewed as devalued in the male-dominated culture. These interpersonal theoreticians stress cultural emphases on different attributes for men and women and are less concentrated on the internal world of unconscious phantasies and internal object relationships.

Jessica Benjamin in *Bonds of Love* (1988) sees both boys and girls as looking to the father for confirmation of themselves. While the boy's identity is confirmed by the father, the girl in contrast has her identification with the father's power denied, and he becomes the object of her ideal ego. This prevents her from having a "desire of her own," and her longing for the father becomes tinged with masochism. Issues of power and submission are located in the sphere of relationships.

Chodorow has argued that what all these authors have in common, in spite of their differences, is the emphasis on the qualities of the "self in relation" (or denial of relation). She suggests that this view radically breaks with an essentialist view of gender and moves towards a view that perceives masculinity and femininity in a contingent, relationally constructed context. These schools, however, end up by constructing a more fixed view of femininity and masculinity than Freud, who basically indicated that there is a fluidity between masculinity and femininity in both men and women.

These views can be contrasted with the major trends in French theories on psychoanalysis and feminism, where there is an emphasis on unconscious fantasies and desire and an attempt to find a language to express the feminine. Among the French psychoanalysts in particular there is a view that the discovery of the unconscious in itself reveals the precariousness of identity in the forces of fantasy and desire. This is the radical perspective that psychoanalysis can offer to feminism. The impact of Jacques Lacan's work pervades the numerous writings, from those who accept basic tenets of Freudian theory to those who, like Julia Kristeva, Helene Cixous, Michele Montrelay, Sarah

Kofman, and Luce Irigaray, remained highly critical of psychoanalytic assumptions.

Lacan pointed out that the distinction between penis and phallus is fundamental to Freud's differentiation between biological and psychic reality. The phallus exists outside anatomical reality and is the signifier of the mother's desire. Joël Dor has suggested that the central question of the Oedipus complex thus becomes "to be or not to be the phallus," i.e. to be or not to be the object of the mother's desire. The role of the father also becomes symbolic—he represents the impossibility of being the object of mother's desire. The phallus, unlike the penis, is possessed by nobody (male or female) and represents the combination of both sexes.

Chasseguet-Smirgel, McDougall, Torok, Luquet-Parat, Monique Cournut-Janin, and Jacqueline Schaeffer have all argued from a position inside psychoanalysis. Chasseguet-Smirgel indicated her perception that the little girl is aware of the existence of the vagina virtually from the beginning, although she also suggests that this "knowledge" may be held unconsciously, so that the little girl both knows and does not know. In her various works, "penis envy" is understood as having a defensive function.

For many of the French feminist writers the body is the locus of femininity, and numerous writings attempt to capture its rhythms (such as Luce Irigaray's *Ce sexe qui n'en est pas un*). In her book *Speculum* (1974), Irigaray perceives psychoanalysis as unaware of the historical and philosophical determinants of its own discourse and unable to analyse its own unconscious fantasies. Furthermore, being a product of patriarchal society, it cannot analyse what it owes to the mother. She consistently puts forward the view that women in patriarchy have no identity as women. She also emphasises the relationship of the little girl to the mother's body. The girl, says Irigaray, "has the mother, in some sense, in her skin, in the humidity of the mucous membranes, in the intimacy of her most intimate parts, in the mystery of her relation to gestation, birth and to her sexual identity."

Kristeva relates psychic repression to the actual structures of language, and describes the pre-oedipal stage as a play of bodily rhythms and pre-linguistic exchanges between infant and mother. Kristeva refers to what Plato, in *Timaeus*, called the *chora* as the site of the undifferentiated bodily space the mother and the

child share. Within the Oedipus complex it is the symbolic that is dominant; the domain of unified texts, cultural representations, and knowledge. This distinction between the semiotic and the symbolic is retrospective, as it is only through the symbolic that one has access to the semiotic. For Kristeva, subjectivity is founded on a constitutive repression of the maternal, the *chora*, the semiotic, and the abject (liminal states, like pregnancy). Kristeva has been accused of reducing women to the maternal function, but she is also seen as providing a deepening in the understanding of the pre-oedipal.

In these French feminist writings, there is a profound search for the multiplicity which characterizes femininity (as opposed to masculinity), which may be expressed in a language which itself attempts to capture the feminine. In a paradoxical way one may be referred back to Freud's thinking about hysteria. The symptoms of the first patient of psychoanalysis, Anna O., included mutism, paralysis, "time-missing," and gaps in memory: all expressing interruptions in the domain of a reality which is being denied. Psychoanalysis indicates that sexuality is only created through division and discontinuity, although femininity is the side that both represents, and tends to be represented as, the negative (of masculinity).

ROSINE JOZEF PERELBERG

See also: Cinema and psychoanalysis; Femininity; Boundary violations; *Psyche. Zeitschrift für Psychoanalyse und ihrer Anwendungen*.

### Bibliography

- Mitchell, Juliet. (1974). *Psychoanalysis and feminism*. Harmondsworth, UK: Penguin Books.
- Raphael-Leff, Joan, and Perelberg, Rosine Jozef (Eds.) (1997). *Female experience: Three generations of British women psychoanalysts on work with women*. London: Routledge.
- Wright, Elizabeth. (1992). *Feminism and psychoanalysis: A critical dictionary*. Oxford, UK: Blackwell.

---

## FENICHEL, OTTO (1897–1946)

Otto Fenichel, an Austrian physician and psychoanalyst, was born in Vienna on December 2, 1897, and died in Los Angeles on January 22, 1946. He was born into a family of Viennese Jewish lawyers. As a student he took

part in the Viennese youth movement that had coalesced around Siegfried Bernfeld. He took an interest in cultural and educational reform and was especially interested in information about sexuality and its scientific study. Released from serving in the military, he began, after the winter of 1915/1916, to attend Sigmund Freud's presentations at the University of Vienna, and after 1918 he participated in discussions held by the Vienna Psychoanalytic Society. In February 1919 he organized, at the university, a Viennese Seminar on Sexology, a working group to study psychoanalysis and sexual matters. In 1920, while still a student, he was accepted as a member of the Vienna Psychoanalytic Society after his talk on sexual problems in youth movements. He received his medical degree in 1921.

Fenichel began an analysis in Vienna with Paul Federn and continued, after moving to Berlin, with Sándor Radó. In 1926 he became a teacher at the Berlin Psychoanalytic Institute and that same year organized a seminar on child psychoanalysis, an open forum on the problems of clinical and applied psychoanalysis. He was a member of the German Psychoanalytic Society from 1926 to 1934. After 1932 some members of the seminar began discussing psychoanalytic issues from a Marxist perspective. Fenichel had to flee to Oslo, Norway, in 1933. There he became secretary of the Dansk-Norsk Psykoanalytisk Forening (Danish-Norwegian Psychoanalytical Society).

In Norway, in the spring of 1934, he continued the meetings on Marxist psychoanalysis, writing clandestine circular letters that he sent to his colleagues in exile. By 1945 he had written 119 such letters. In 1935 he moved to the Czechoslovak city of Prague, where he ran the Prager Arbeitsgemeinschaft (Prague Study Society), which was associated with the Vienna Psychoanalytic Society.

After the introduction of National Socialism in Vienna and the dissolution of the Prague group, in the spring of 1938 Fenichel and his family left for Los Angeles. There he joined the Los Angeles Psychoanalytic Study Group. In 1942 he helped found the San Francisco Psychoanalytic Society and in 1944 became vice president. After 1939 he was an editor of the *Psychoanalytic Quarterly*. In the summer of 1945 he began studying psychiatry to obtain his California license at the Cedars of Lebanon Hospital in Los Angeles.

The focus of his interest, which he shared with Siegfried Bernfeld, Wilhelm Reich, Erich Fromm, and

others, lie in the development of a form of psychoanalysis that provided sociological explanations and was capable of making contributions to politics. His most important work, *The Psychoanalytic Theory of Neurosis*, appeared in 1945 and became a key source for analytic training. One of Fenichel's most important contributions to psychoanalysis, overlooked until 1998, has been his circular letters, which have shown him to be an important historiographer of the psychoanalytic movement.

ELKE MÜHLLITNER

*Work discussed: Psychoanalytic Theory of Neurosis, The.*

*See also:* Addiction; American Imago; Asthma; Berliner Psychoanalytisches Institut; Boredom; Bulimia; Claustrophobia; Czech Republic; Dependence; Dipsomania; Evenly-suspended attention; Germany; Indications and contraindications for psychoanalysis for an adult; Lehrinstitut de Wiener Psychoanalytischen Vereinigung; Narcissism of minor differences; "Neurasthenia and 'Anxiety Neurosis'"; Norway; Oedipus complex, early; Politics and psychoanalysis; Stammering; Tics; Transference relationship; Wiener psychoanalytische Vereinigung; Second World War: The effect on the development of psychoanalysis; United States.

### **Bibliography**

- Fenichel, Otto. (1945). *The psychoanalytic theory of neuroses*. New York: W. W. Norton.
- . (1953–1954). *The collected papers of Otto Fenichel*. New York: W. W. Norton.
- . (1998). 119 Rundbriefe (1934–1945) (2 vols.). Frankfurt am Main: Stroemfeld.
- Mühlleitner, Elke. (1992). *Biographisches lexikon der psychoanalyse: die Mitglieder der psychologischen Mittwoch-Gesellschaft und der Wiener psychoanalytischen Vereinigung, 1902–1938*. Tübingen, Germany: Diskord.

---

**FEPAL.** *See* Federacion psicoanalitica de America Latina

---

## **FERENCZI, SÁNDOR (1873–1933)**

A Hungarian neurologist and psychoanalyst, Sándor Ferenczi was born in Miskolc on July 7, 1873, and died in Budapest on May 22, 1933. He was the eighth of eleven children of Baruch Fraenkel (who changed his

name to Bernát Ferenczi), a bookseller, printer, and ticket agent, and Róza Eibenschütz, both of whom were Jews from Galicia, Poland. His father died when he was fifteen. After studying at the Protestant school in his home town, Ferenczi went to Vienna to study medicine, obtaining his diploma in 1894. He became interested in psychology while still a student.

Ferenczi first practiced medicine at the Rókus Hospital in Budapest and then specialized in neurology at the Szent Erzsébet (Saint Elizabeth) Hospital. After 1899 he contributed to the medical journal *Gyógyászat* (Therapeutics). These early articles demonstrate Ferenczi's interest in clinical medicine and psychology.

Ferenczi read Freud's *Interpretation of Dreams* shortly after its appearance but was not impressed by the work. A few years later, after he adopted Carl Gustav Jung's association test, he became more receptive to Freud's ideas, and on February 2, 1908, together with another Hungarian doctor, he made his first visit to Freud. This was the beginning of a close friendship between the two men that lasted until Ferenczi's death. In 1908 they began their correspondence (comprising approximately one thousand four hundred letters), an exchange that had a profound effect on the history of psychoanalysis. At the first psychoanalytic meeting, which took place in Salzburg on April 27, 1908, Ferenczi presented the paper "Psychoanalysis and Pedagogy," the first psychoanalytic work devoted to the subject.

Because many of his friends were writers and artists, Ferenczi played an active role in the cultural life of Budapest, which was being swept at this time by currents of modernism. The Freudian ideas for which he became the spokesman were well received by his writer friends but rejected by most medical doctors.

To help introduce psychoanalysis to Hungary, Ferenczi gave a number of talks. He gradually became Freud's closest disciple and spent a number of summer vacations with the Freud family, often traveling with Freud. In 1909, when Freud visited Clark University in the United States, Ferenczi accompanied him (along with Jung) and helped prepare his presentations. In 1909 Ferenczi published "Introjection et transfert" (Introjection and transference; 1990a), his first theoretical work.

In 1910, following a suggestion by Freud, he proposed the creation of the International Psychoanalytical Association with Jung as president, and in 1913 founded the Hungarian Psychoanalytic Association

with István Hollós (a psychiatrist), Lajos Lévy (a doctor), Sándor Radó (a medical student), and Hugo Ignotus (whose real name was Hugo Veigelsberg and who was the editor-in-chief of the avant-garde literary review *Nyugat* [The Occident]). That same year Ernest Jones began analysis with Ferenczi.

After experiencing a series of personal problems in 1911 (his interminable hesitation between Gizella Pálos, a married woman and his mistress since 1905, and Elma, her eldest daughter), Ferenczi asked Freud to analyze him. The analysis took place in three parts, one in 1914 and the other two in 1916. The analysis was cut short by the First World War, but also by Freud's reluctance to get involved in matters he feared, not without reason, would have negative repercussions on their relationship. In the end Ferenczi married Gizella in 1919 without ever completely forgiving Freud for having influenced his decision. In 1916 Ferenczi undertook the analysis of Géza Roheim and Melanie Klein and played a key role in discovering their talent.

September 1918 marked the highpoint of psychoanalysis in Hungary. The Fifth International Congress took place at the Academy of Sciences in Budapest, with participation of representatives from the government, who were interested in psychoanalytic work on war neuroses. During the congress, Ferenczi was elected president of the International Psychoanalytical Association. A few months later, because of political and social events in Hungary, which was then independent of Austria, Ernest Jones succeeded him as president. The following year, during the short-lived Hungarian Commune, Ferenczi obtained a chair in psychoanalysis at the university. This was taken from him when the right-wing government under Miklós Horthy came to power. In 1920 he was also expelled from the Hungarian medical association.

After 1919 Ferenczi devoted himself exclusively to the care of his patients and the development of the psychoanalytic movement. In 1925, with Vilma Kovács, one of his analysands and students, he worked out the methods of a system of training, and in 1931 he founded a psychoanalytic clinic, with himself as director. At the same time he continued his research and theoretical work, which focused primarily on technique.

In 1924 Ferenczi and Otto Rank published *Entwicklungsziele der Psychoanalyse* (*The development of psychoanalysis* [1925]). The book was criticized,

principally by Karl Abraham and Ernest Jones, and then by Freud. When Rank broke with Freud, Ferenczi reaffirmed his commitment to Freud and published an article criticizing Rank's work. In 1924 he published *Thalassa* (1963), a work highly regarded by Freud for its use of Lamarckian ideas.

In 1926 and 1927 Ferenczi spent six months in the United States giving lectures and training candidates, not all of whom were doctors. His position in favor of lay analysis alienated a large part of the American psychoanalytic community, which was committed to limiting psychoanalytic practice to medical doctors.

Ferenczi's technical experiments between 1918 and 1932, which were conducted to make psychoanalysis accessible to patients who showed signs of pregenital disturbances, created dissension between him and Freud. The conflict embittered his final years and affected the entire psychoanalytic community. He gave his last lecture, "Confusion of Tongues between Adults and the Child" (1949), in 1932 at the Wiesbaden Congress. Already suffering from pernicious anemia, he died on May 22, 1933, in Budapest.

Ferenczi made an important contribution to psychoanalytic theory and technique. On the theoretical level, he introduced the concept of introjection, was the first to focus on object relations, and developed theories of trauma and regression. In *Thalassa* he presented a number of fertile hypotheses on the ontogenesis and phylogensis of genitality, or a sex life.

Above all, Ferenczi thought of himself as a doctor and held that it was not up to the patient to present himself as analyzable but up to the analyst to find suitable techniques for healing his patients. He successfully developed several therapeutic techniques:

1. He developed the so-called active technique, whereby the analysand is asked to do whatever will promote free associations or to refrain from doing whatever might impede them.
2. To help mediate the authoritarian nature of the active method, he developed the technique of elasticity and permissiveness. Here, pushing tolerance of regression to its extremes, he allowed the traumatized patient to experience his symptoms anew.
3. He developed what is known as mutual analysis—an attempt doomed to failure and quickly abandoned—which was intended to spare

traumatized patients the consequences of misunderstanding and blind spots on the part of the analyst.

Ferenczi occupies an important place in the development of psychoanalysis and psychoanalytic theory and played an important role in propagating psychoanalytic ideas and contributing to the understanding and global awareness of psychoanalysis. His disagreement with Freud during the last years of his life, as well as the uneasiness caused by the almost superhuman demands he made on the analyst, have relegated his work to obscurity for nearly fifty years. However, on closer examination of the history of the twentieth century, the relevance of his ideas becomes obvious. Owing to the efforts of Michael Balint, who edited Ferenczi's collected works, and the appearance in 1988 of his *Clinical Diary*, a unique document in the field of psychoanalysis, the value of his ideas has been recognized wherever psychoanalysis is practiced.

EVA BRABANT-GERÖ

*Works discussed:* "Confusion of Tongues between Adults and the Child"; "Development of Psycho-Analysis"; "Dream of the Wise Baby, The"; "Introjection and transference"; *Thalassa. A Theory of Genitality*.

*Notions developed:* Active technique; Amphimixia/amphimixis; Elasticity; Introjection; Mutual analysis; Relaxation principle and neo-catharsis; Tact.

*See also:* Abstinence/rule of abstinence; "Analysis Terminable and Interminable"; Anticipatory ideas; Autoplastic; Benign/malignant regression; Boredom; Boundary violations; Character neurosis; Clark University; Criminology and psychoanalysis; Erotogenic zone; Homosexuality; Hungarian School; Hungary; Identification; International Psychoanalytic Association; Knowledge, instinct for; Lie; Negative hallucination; Neutrality/benevolent neutrality; Nudity, dream of; Choice of neurosis; Occultism; Omnipotence of thought; Orgasm; Passion; Pleasure in thinking; Primary love; Psychic causality; Psychoanalytic filiations; Real trauma; Secret Committee; Seduction scenes; Splitting of the ego; Technique with adults, psychoanalytic; Telepathy; Tenderness; Termination of treatment; Tics; Training analysis; Transference; Transference depression; Wish, satisfactory hallucination of a.

### **Bibliography**

Ferenczi, Sándor. (1949). Confusion of tongues between adults and the child. *International Journal of Psycho-Analysis*, 30, 225–230.



- . (1963). *Thalassa: A theory of genitality* (Henry Alden Bunker, Trans.). New York: W. W. Norton. (Original work published 1924)
- . (1974). Les fantasmes provoqués. In his *Oeuvres complètes. Psychanalyse* (Vol. 3). Paris: Payot. (Original work published 1924)
- . (1988). *The clinical diary of Sándor Ferenczi* (Michael Balint and Nicola Zarday Jackson, Trans.). Cambridge, MA: Harvard University Press.
- . (1990a). Introjection et transfert. In his *Oeuvres complètes. Psychanalyse* (Vol. 1). Paris: Payot. (Original work published 1909)
- . (1990b). Le développement du sens de la réalité et ses stades. In his *Oeuvres complètes. Psychanalyse* (Vol. 2, pp. 51–64). Paris: Payot. (Original work published 1913)
- . (1996). Le traumatisme psychique. In his *Oeuvres complètes. Psychanalyse* (Vol. 4, pp. 82–97). Paris: Payot. (Original work published 1932)
- Ferenczi, Sándor, and Rank, Otto. (1925). *The development of psychoanalysis* (Caroline Newton, Trans.). New York: Nervous and Mental Disease Publishing Co. (Original work published 1924)

## FETISHISM

Fetishism first interested psychoanalysts as a sexual perversion, in the strict sense. The term referred to a man's compulsive use of an inherently nonsexual object as an essential condition for maintaining potency and achieving pleasure when having sexual relations with a person of the opposite sex. This view emphasizes that perversion, as originally understood, was viewed as a strictly masculine phenomenon. Freud presented his thinking on the subject in three texts, which represented his changing ideas on the subject: *Three Essays on the Theory of Sexuality* (1905d), "Fetishism" (1927e), and "The Splitting of the Ego in the Process of Defense" (1940e [1938]). The views expressed in those essays are as relevant in the early twenty-first century as when they were first written.

In all observed cases, the fetish, in the fetishist's unconscious fantasy, is a substitute for a woman's "penis." It "completes" the woman by making her phallic. Consequently, the woman's genital organs lose any erogenous quality, in the eyes of the fetishist, erogeneity being completely transferred to the fetish. The fetish becomes the source of excitement, an idealized object capable of providing sexual pleasure to the fetishist.

The psychopathological behavior of the fetishist can be considered exacerbation of a universal anxiety. Freud saw in this perversion one of the clearest demonstrations of the difficulty that some men (perhaps all men) experience in accepting the differences of the sexes.

It has become clear that the most important factor behind this perversion is castration anxiety experienced to an extreme degree. Fetishism arises entirely from defensive measures unconsciously adopted to reject castration and eliminate it from the field of possibility. Only a part of the man believes that a woman does not have a penis. So as far as the fetishist is concerned, castration is still possible under these circumstances. But if both sexes are equipped with a penis, castration cannot occur in this world. It thus becomes essential to remedy this unacceptable reality by attributing a penis to the woman at any cost. Creating such a reality is the primary function of the fetish in the unconscious imagination of the fetishist. The fetishist must then shelter his fragile mental apparatus from the return of disturbing sexual perceptions. He does so by choosing as a fetish an object that is always available, like a high-heel shoe. One fetishist is quoted as saying, "Every time I am in the presence of a naked woman, I imagine a high-heel shoe; I couldn't tell what a vagina looks like." As Freud demonstrated, the fetish makes the woman "acceptable" as an object of sexual love.

Freud considered fetishism important because this pathological structure can be used to observe the workings of two important defense mechanisms that had been partially ignored until then: splitting and denial. Fetishism enabled Freud clearly to identify the mechanism of splitting for the first time, that is, splitting of the thinking ego (to be distinguished from the splitting of the object representation). The fetishist demonstrates that he can accommodate two clearly contradictory conceptions of a woman within himself: a conscious affirmation ("The woman does not have a penis") and an unconscious fetishistic affirmation ("The woman has a penis"). The first is unimportant in the mental representations of the fetishist. These two modes of thought operate in parallel and have no effect on one another. The second mode of thought, a defense mechanism, denies castration, the lack of a penis, the crucial difference between the sexes. Most authors see splitting as arising to ensure the continuity of the denial, though it may be that splitting and continuity of denial occur simultaneously.

Since splitting and denial are observed in psychosis, some see fetishism as a protection against an otherwise threatening psychosis. Fetishism is also thought to protect against homosexuality. We should not conclude, however, that the fetishist is homosexual. In terms of his own feelings of identity and his own self-representations at all levels of thought, he sees himself as a man, a man in relation to a woman, except that the woman in this case also has a penis, according to the man's unconscious imagination. This is a major difference with the transvestite, who sees himself as a woman, in this case, a woman with a penis. Overall, in spite of the exceptions encountered, the transvestite is much closer to homosexuality than the fetishist. Rare cases of fetishism alternating with homosexuality have been observed, however.

It follows from the above that fetishism is a sign of narcissistic pathology, with mental operations functioning at a very archaic level, primarily through the extensive use of primitive identification (which some authors refer to as "narcissistic identification" or "projective identification"). This assertion is based on the fact that by endowing the woman (the mother, in the unconscious) with a penis, the fetishist preserves his own sexual organ by identifying with the mother. In doing so, the fetishist exhibits considerable narcissistic vulnerability regarding the integrity of his physical image.

Although opinions are divided, it seems justified to view the mechanism and structure of fetishism as resulting from a massive regression following the oedipal stage. The oedipal conflict was traumatic and results in significant regression to all levels of pregenitality, accompanied by strong anal and oral components. These components are manifest in an anxiety of disintegration, which is very noticeable during psychoanalysis. Another school of thought suggests viewing fetishism as essentially determined by pregenital conflicts.

Psychoanalytic work in the 1990s has shown that the fetish can also take on, in most cases, several other functions in varying proportions. These secondary functions include protection against trauma and depression, release from the outward expression of hostility and contempt while expressing them secretly, relief from psychosomatic symptoms, control over separation anxiety. As a partial delusion, fetishism protects the subject from the delusion. And finally, fetishism provides access to the maternal breast and full possession of the idealized mother.

ANDRÉ LUSSIER

*See also:* Castration complex; Coprophilia; Disavowal; Phallic mother; Phallic woman; Psychotic defenses; "Splitting of the Ego in the Process of Defence, The."

### **Bibliography**

- Freud, Sigmund. (1905d). Three essays on the theory of sexuality. *SE*, 7: 123–243.
- . (1927e). Fetishism. *SE*, 21: 147–157.
- . (1940e [1938]). Splitting of the ego in the process of defence. *SE*, 23: 271–278.
- Gillespie, William H. (1964). The psychoanalytic theory of sexual deviation with special reference to fetishism. In Ismond Rosen (Ed.), *The pathology and treatment of sexual deviation* (pp. 123–145). London: Oxford University Press.
- Lussier, André. (1983). Les déviations du désir: Étude sur le fétichisme. *Revue Française de Psychanalyse*, 47 (1), 19–142.
- Rosolato, Guy. (1967). Étude des perversions sexuelles à partir du fétichisme. In Guy Rosolato, Piera Aulagnier-Spairani, Jean Clavreul, François Perrier, and Jean-Paul Valabrega (Eds.), *Le désir et la perversion* (pp. 9–52). Paris: Seuil.

### **Further Reading**

- Bak, Robert. (1953). Fetishism. *Journal of the American Psychoanalytic Association*, 1, 285–298.
- Greenacre, Phyllis. (1960). Further notes on fetishism. *Psychoanalytic Study of the Child*, 15, 191–207.
- . (1969). The fetish and the transitional object. *Psychoanalytic Study of the Child*, 24, 144–164.
- Nersessian, Edward. (1998). A cat as fetish: A contribution to the theory of fetishism. *International Journal of Psychoanalysis*, 79, 713–726.
- Renik, Owen. (1992). Use of the analyst as a fetish. *Psychoanalytic Quarterly*, 61, 542–563.

---

**FILIATIONS.** *See* Psychoanalytic filiations

---

**FILM.** *See* Cinema criticism; Cinema and Psychoanalysis

---

## **FINLAND**

Psychoanalysis was practically nonexistent in Finland until it experienced rapid growth during the 1960s.

The first Finnish psychoanalyst, Yrjö Kulovesi (1887–1943), underwent analysis with Eduard Hitschmann in Vienna in 1924, then with Paul Federn in 1925. He became a member of the Vienna Psychoanalytic Society in 1931 and in 1934 went on to found, together with the Swedish psychoanalyst Alfhild Tamm, the Finno-Swedish Psychoanalytic Society, which was dissolved in 1943 after Kulovesi's death. A training analyst, he wrote several articles and an introduction to psychoanalysis, published in 1933.

A number of Finnish psychoanalysts emigrated to Sweden during the 1940s. After the war most of them were members of the Swedish Psychoanalytic Society. They included Stig Björk, Pentti Ikonen, Tapio Nousiainen, and Veikko Tähkä. A few years later Mikael Enckell, Reijo Holmström, Eero Rechartt, Matti Tuovinen, and Gunvor Vuoristo also traveled to Sweden for training in analysis. During this same period, three other psychoanalysts underwent similar training in Switzerland: Henrik Carpelan in Geneva, and Leena-Maija Jokipaltio and Lars-Johan Schalin in Zurich.

The biggest problem at the time was the shortage of psychoanalysts in Finland. Psychoanalysts trained abroad needed certification from the International Psychoanalytic Association (IPA) to work as training analysts in Finland. In 1964 Björk and Tähkä, trained in Sweden and members of the Swedish Psychoanalytic Society since the mid-1950s, formed a study group and became recognized as training analysts. The group, approved by an IPA committee presided over by Donald Winnicott and composed of members from Denmark, Sweden, and Great Britain, was formally recognized in 1967 as a provisional society and became an IPA affiliate in Rome in 1969. By 1974 there were already twenty-six candidates in training. Winnicott was the first honorary member of the Finnish Psychoanalytic Society. At the end of the 1950s, a psychotherapeutic organization, *Therapeia*, was founded, its methods inspired by existential analysis.

Academic resistance to psychoanalysis was less severe in Finland than in the other Nordic countries. The majority of Finnish psychoanalysts were psychiatrists. Tähkä, a professor of psychiatry at the University of Turku, twice visited the Austin Riggs Center in the United States for two years each time. The use of American ego psychology at the center led him to follow in this tradition, which is obvious from his book on psychoanalytic therapy (1970). Tähkä was most interested in research on alcoholism and schizophre-

nia. Kalle Achté was a professor of psychiatry and senior psychiatrist at the University of Helsinki. He conducted research on persecution and projection as defense mechanisms. Rechartt worked on psychosomatic illnesses and the evolution of ego psychology toward self psychology.

Yrjö Alanen, like Tähkä, studied the role of family factors in schizophrenia and applied psychoanalytic therapy in a family context. Tuovinen, a psychiatrist and lawyer, did psychoanalytic research on delinquent behavior and in particular analyzed aggression as a form of parental murder and suicide. Mikael Enckell, another important Finnish psychoanalyst, wrote several works on the Jewish question, the novelist Marcel Proust, the poet Friedrich Hölderlin, the filmmaker Luchino Visconti, and his own father, the poet Rabbe Enckell.

Finnish psychoanalysis was generally associated with ego psychology. Carpelan, trained in Geneva, is one of the few Finnish analysts to have a Kleinian orientation. He was president of the Finnish Group Therapy Association.

The traditional theoretical training period for psychoanalysts in Finland was extended from three years to four. The fourth year of training is devoted to the study of the relationship between psychoanalysis and the other sciences and of the theoretical and technical aspects of psychotherapy.

During the 1980s the Finnish Psychoanalytic Society (Suomen Psykoanalyttinen Yhdistys) underwent a period of rapid growth. In 2004 it had as many members as the Swedish Psychoanalytic Society. In the early 1980s it began offering training in child analysis, and in 1983 four candidates entered the program. In 1983 the Finnish Psychoanalytic Society had twenty-two full members, fifty-four associate members, and twenty-seven candidates. In 1993 there were forty-eight full members, ninety associates, and thirty-seven candidates.

During the late 1980s, several translations of Freud's work were published in Finland.

PER MAGNUS JOHANSSON

### **Bibliography**

Ihanus, Juhani. (1994). *Vietit vai Henki*. Helsinki, Finland: Yliopistopaino.

Kulovesi, Yrjö. (1933). *Psykoanalyysi*. Helsinki, Finland: Otava.

Laine, Aira, Parland, Helena, and Roos, Esa. (1997). *Pssykoanalyysin, uranuurtajat Suomessa*. Kemijärvi, Finland: Suomen Psykoanalyttinen Yhdistys R.Y.

Tähkä, Veikko. (1970). *Psykoterapian perusteet: psykoanalyttisen teorian pohjalta*. Porvoo, Finland: Söderström.

## FIRST WORLD WAR: THE EFFECT ON THE DEVELOPMENT OF PSYCHOANALYSIS

In July 1914 Sigmund Freud was more preoccupied with Carl Gustav Jung's resignation ("Finally, we are rid of Jung, that crazy brute, and his acolytes!" he wrote to Karl Abraham on July 26) than the war that Austria, following the assassination of Archduke Ferdinand in Sarajevo on June 28, had declared against Serbia. "This may be the first time in thirty years that I feel Austrian," he added. He was so unaffected that he allowed his daughter Anna to leave for Great Britain at the beginning of the month. The real problem was organizing the international congress that was supposed to take place that fall in Dresden, but that ultimately took place four years later in Budapest.

The general conflict let loose in August disturbed this sense of calm. Freud's sons weren't mobilized at the start of the war, and the progress of German troops made him hope for an early victory. "My heart would be with the combatants if I didn't know that England finds itself on the wrong side," Freud wrote on August 2, preoccupied with Anna's repatriation through Gibraltar and Genoa, which took place at the end of the month with the help of Ernest Jones ("he is obviously our 'enemy'"). Martin Freud joined the artillery: "According to his letter," his father wrote, "he didn't want to lose the opportunity to cross the Russian border without changing his religion." Karl Abraham wrote to Freud on August 29, 1914, "The news is excellent now, isn't it? The German troops are barely one hundred kilometers from Paris, Belgium has been liquidated, and England is on its last legs. Russia isn't doing much better." On September 13 he added, "During the next few days, we hope to have favorable news of the fighting along the Marne. If this ends well, France's fate will be pretty much sealed, that is, securing fortified positions in the southeast will be only a matter of days."

The principal concern appears to have been the publication of *Zeitschrift* and *Imago* with the help of Otto Rank, while Sándor Ferenczi traveled to Vienna at

the end of September for an analysis with Freud. Freud had begun writing the "Wolfman," which was published in 1918, but his morale was shaken by the announcement on October 17 of the death of Emanuel, his half-brother, after falling from a train, and then by the global expansion of the war on November 2.

On December 24, 1914, he wrote to Jones, "I have no illusions and realize that the expansion of our science has now been interrupted, that we are heading toward a bad period, and that all we can hope for is to maintain the embers in a few hearths, while waiting for a more favorable wind to help us build it up into a blaze. What Jung and Adler have left of the movement is now crumbling because of the dissension among nations. The *Verein* is no more tenable than anything having an international dimension. Our reviews will soon cease publication; we may manage to continue the *Zeitschrift*. . . . The future of the cause, which is so dear to you, does not bother me, naturally, but the immediate future, the only one I can take an interest in, appears desperately dark and I wouldn't cast a stone at the rat abandoning the ship." Because he had fewer patients, he had more time, and so announced, "I am again going to try to put whatever I can contribute into a summary."

These were the twelve essays on metapsychology that were to occupy Freud throughout 1915 not only as a necessary synthesis at a time of upheaval but as an essential next step in developing his ideas. This followed the publication of "On Narcissism: An Introduction" at the beginning of the year, which shook the foundations of psychoanalytic theory by questioning the opposition between "libidinal drives" and "self-preservation drives." The essay on melancholia was the subject of extensive correspondence with Karl Abraham, which allowed Freud to stress the fact that in the future any psychoanalytic explanation of an "affect can only be provided through its mechanism, considered from a dynamic, topological, and economic point of view" (letter of May 15, 1915). On that same day he wrote, "My work is taking shape. I have completed five essays: the one on Instincts and their Vicissitudes, which is of course somewhat dry but essential as an introduction, and will be justified in the following articles, then Repression, the Unconscious, A Metapsychological Supplement to the Theory of Dreams, and Mourning and Melancholy. The first four will be published in the *Zeitschrift* series currently underway; I will keep the rest for myself. If the war lasts long

enough, I hope to be able to combine about a dozen similar essays and publish them, in calmer times, to the uncomprehending public, with the title *Preliminary Essays on Metapsychology*. I feel that, overall, this represents progress. Same genre and same level as section VII of the *Interpretation of Dreams*.” In 1915 he also published “Thoughts for the Times on War and Death” (1915b), the first in-depth essay on violence, hatred, and the illusion of primal kindness, an essay that provides perspective for the future conceptualization of the death drive. On July 30, 1915, he wrote to Lou Andreas-Salomé, “It is impossible to say when we will be able to meet, we, the scattered members of an apolitical community, nor, when the moment arrives, will we know the extent to which we have been corrupted by politics.”

Ernst Freud fought in Galicia, Martin was slightly wounded, most of Freud’s followers were mobilized except for Hanns Sachs who had been deferred for nearsightedness, and meetings of the Vienna Psychoanalytic Society became increasingly less frequent. The fall of 1915 was a busy one. Freud gave a series of lectures that, after being continued during the winter of 1916–1917, formed the basis for the *Introductory Lectures on Psychoanalysis* (1916–1917a). In December Rainer Maria Rilke visited Freud and unsuccessful efforts were made to obtain the Nobel Prize for him. In January 1916 Freud’s isolation increased with the departure of Otto Rank for Krakow.

The year 1916 was relatively quiet for psychoanalysis, other than Freud’s sixtieth birthday in May. Like the rest of the population, Freud had grown weary of the incessant slaughter, the lies, the cold and hunger. The first generation of psychoanalysts were scattered across enemy territory but, being for the most part mobilized in the medical corps, they largely escaped death. The first really good news came in 1918 when Freud discovered Ernst Simmel’s book *Névroses de guerre et Traumatisme psychique*. “Here for the first time, a German doctor, who relates unequivocally and without condescension to psychoanalysis, who has made use of his position to advocate for the treatment of war neuroses, provides examples to prove it, and shows himself to be completely honest regarding the question of sexual etiology. True, he has not followed psychoanalysis on every point, supports the cathartic point of view, makes use of hypnosis, a method that cannot fail to mask the resistance and strength of the sexual drives; but he alleges with reason the need for

prompt results and the imperatives of sequential efforts. I think that with a year of training he would be a good analyst.” Freud went on to write to Simmel, “few writings by psychoanalytic novices who I do not know personally have given me as much satisfaction as your article” (February 20, 1918).

The time had come to organize a new congress, the first since the Munich congress of 1913. Planned to take place in Breslau, it was ultimately held in Budapest, a city that assumed considerable importance for Freud, primarily because Anton von Freund, one of his analysts, provided material and financial support to the cause of psychoanalysis. “We are going to become materially powerful, we will be able to maintain and develop our publications, have influence; our current poverty is coming to an end. The man to whom we owe all this is not only rich, he is also well intentioned, highly intelligent, and very interested in psychoanalysis. . . . From now on Budapest is going to become the center of our movement.”

The Fifth International Congress on Psychoanalysis was held in Budapest on September 28 and 29, 1918, and Freud spoke on “Wege der psychoanalytischen Therapie” (The paths of psychoanalytic therapy)—an essay that was to have considerable influence on the evolution of the psychoanalytic movement in the next few years. He planned the extension of psychoanalysis for social purposes, the need to blend the copper of suggestion with the pure gold of psychoanalysis, and introduced the idea of providing free treatment for the poor, which was to lead, two years later, to the creation of the Berlin Polyclinic and the Psychoanalytic Institute, which was needed to train psychoanalysts for the growing number of patients. The congress was a success, especially because the increasing problems introduced by war neuroses attracted the attention of the government authorities to the benefits of employing psychoanalytic methods. One month later a revolution broke out in the Hungarian Republic. Béla Kun’s revolutionary government appointed Ferenczi “professor of psychoanalysis” on May 12, 1919; he then assumed direction of the Batizfalvy Sanatorium (from the end of March to the beginning of August 1919).

The armistice on November 11, 1918 provided considerable relief, but Freud was worried about Martin, because he had not heard from him. At the end of the year, he learned that he was a prisoner in Italy and wouldn’t be released until October 1919. From Great Britain, Jones wrote on December 21, 1918, “In

Germany and America there has been much progress of late. Here, psychoanalysis has awakened general interest in every circle and it is even being taught in medical schools; the younger generation is impatient to learn more about it." He went on to say that he was preparing to "hunt down the 'remaining Jungians'" and establish the new British Psycho-Analytical Society and create the *International Journal of Psychoanalysis*.

On April 18, 1919, Freud was able to confirm, "I am still standing and in no way hold myself responsible for the world's absurdity. Psychoanalysis is flourishing, I am delighted to learn, on all sides, and I hope that the science will provide consolation to you as well."

ALAIN DE MIJOLLA

*See also:* Germany; Great Britain; Hungary; International Psychoanalytic Association; "Lines of Advance in Psychoanalytic Therapy"; New York Psychoanalytic Institute; Simmel, Ernst.

### **Bibliography**

Freud, Sigmund and Abraham, Karl. (1965a). *A psychoanalytic dialogue: The letters of Sigmund Freud and Karl Abraham, 1907–1926*. (Hilda C. Abraham and Ernst L. Freud, Eds. and Bernard Marsh and Hilda C. Abraham, Trans.). New York: Basic Books.

Freud, Sigmund, and Jones, Ernest. (1993). *The complete correspondence of Sigmund Freud and Ernest Jones, 1908–1939*. (R. A. Paskauskas, Ed.). London: The Belknap Press of Harvard University Press.

Gay, Peter. (1988). *Freud: A life for our time*. London-Melbourne: Dent.

## **FIVE LECTURES ON PSYCHO-ANALYSIS**

Freud delivered his *Five Lectures on Psycho-Analysis* in September 1909 at Clark University in Worcester, Massachusetts. He had been invited by Stanford Hall in honor of the university's twentieth anniversary. He was accompanied by Carl Gustav Jung, Sándor Ferenczi, and Ernest Jones. Upon their arrival in New York, he was welcomed by Abraham Arden Brill. These lectures were a key moment for the recognition and dissemination of psychoanalysis on an international level. Freud delivered these five lectures in German, without notes, and wrote them up later.

The text was published in English in the *American Journal of Psychology* in 1910. The work went through

eight editions in German, and it was translated into ten languages. In the course of these lectures, Freud first revealed Josef Breuer's role in the discovery of psychoanalysis. Freud recapitulated the case of a young girl (Anna O.) who was suffering from conversion hysteria and whom Breuer had treated. Freud described how catharsis (remembering traumatic events and their attendant affects under hypnosis) suppressed Anna's symptoms. But he quickly abandoned this technique. Research on hysteria being carried out at the same time by Jean Martin Charcot and Pierre Janet, in Paris, and Hippolyte Bernheim, in Nancy, allowed Freud to confirm his own theory. He discerned that a symptom is a disguised form of conflict between the conscious and the unconscious, provoked by incompatible desires, and he discovered the phenomena of resistance and repression.

Next Freud explained the basis for psychoanalytic technique: free association and the interpretation of slips of the tongue and, in particular, dreams, which he called "the royal road to knowledge of the unconscious." Making use of free association, the analyst identifies the latent content hidden behind dreams' manifest content (the actualization of hidden repressed desires) and the processes of condensation and displacement that are an obstacle to understanding the repressed desires.

Freud then approached the central issues of infantile sexuality, the Oedipus complex, and the sexual origins of neurosis. He showed the existence of transference by noting that in the relationship with the analyst, the patient relives old affects and repressed desires that have become unconscious and are returned to consciousness under the influence of transference. Finally, Freud refuted objections against psychoanalysis stemming from the fear that the liberation of repressed desires might endanger morality and social life. He believed that psychoanalysis, by bringing these desires back into consciousness, enabled people to accept and master them—or better yet, sublimate them.

These five lectures, written in a simple, lively style and filled with anecdotes, describe the origins of psychoanalysis and the trajectory of Freud's thinking up until the end of 1909.

MAÏTÉ KLAHR AND CLAUDIE MILLOT

*See also:* Clark University.

**Source Citation**

Freud, Sigmund. (1910a [1909]). Five lectures on psychoanalysis. *SE*, 11: 7–55.

**Bibliography**

Jones, Ernest. (1953–1957). *Sigmund Freud: Life and work*. London: Hogarth.

**FIXATION**

The notion of fixation involves a certain mode of connection that a drive has with its ideational representatives (its objects) as a function of a primitive phase of the subject's sexual organization. This mode of connection is characterized, at the economic level, by the withdrawal from general circulation of more or less significant quantities of libido. On the dynamic level it is marked by the absence of mobility of the drive in question. On the topographical level, the connection is inscribed in the unconscious.

In Freud's work, the idea of fixation is theoretically associated with four other notions: traumatism, regression, repression, and predisposition. These form the successive stages of Freud's elaboration of the concept of fixation.

The notion of fixation first appeared in a context, which would later turn up again, that is associated with Freud's first work on the psychoneuroses of defense around the time of the *Studies on Hysteria* (1895d): "The traumatic neuroses give a clear indication that a fixation to the moment of the traumatic accident lies at their root" (1916–17a, p. 274). The fixation to the trauma accounts for the neurotic disorder and for the patient's inability to master the affect contained in the traumatic events. Thus the first version of fixation is dominated by the economic dimension.

The notion of fixation next appeared in the *Three Essays* (1905d): "[W]e propose to describe the lagging behind of a part trend at an earlier stage as a *fixation*—a fixation, that is, of the [drive]....[T]he portions which have proceeded further may also easily return retrogressively to one of these earlier stages—what we describe as regression" (p. 340).

In the Freudian conception of infantile sexuality, the sexual function develops according to a graduated rhythm. A partial drive may either pursue a development that achieves the ability to organize freely circulating energy under the aegis of the oedipal genital

structures, or stop at some point along the way, lagging behind by fixing upon an earlier stage of sexual development or a primitive object of satisfaction. In clinical work, perversions, just like neurotic symptoms, are evidence of libidinal vestiges from the past.

Fixation appeared in a third context in regard to the case of Daniel Paul Schreber: "The libidinal current in question then behaves in relation to later psychological structures like one belonging to the system of the unconscious, like one that is repressed" (1911c, p. 66). For Freud, in fact, the psychical representatives of component drives are made the object of a fixation that then falls under repression. Similarly, in the formation of symptoms the return of the repressed goes back to the very point of fixation to which the libido has regressed.

Finally, the notion of fixation is associated, in Freud's teaching, with that of sexual constitution insofar as it brings together the various ways in which the different components of the libido are inscribed in the early stages of its development. Fixation thus represents predisposition as a factor in the etiology of neuroses.

The notion of fixation can be found in other currents of psychoanalytic thought, particularly in that of Pierre Marty, whose work represents an original contribution to the concept. For him, the fixation-regression system forms the basis of any functional organization and has a field of influence that stretches from mental to somatic functions. In the course of any psychosomatic disturbance, the presence of fixations, whether psychical or somatic, constitute the stopping points of a counter-developmental current, points from which a psychosomatic reorganization can take place. According to this point of view, the fixation-regression system represents the set of defensive capacities in the development of each individual.

CLAUDE SMADJA

*See also:* Cathexis; Choice of neurosis; Constitution; Disorganization; Ego states; Libidinal development; Psychic causality; Psychic temporality; Psychosomatic; Regression; Repression; Self-object; Stage (or phase); Traumatic neurosis.

**Bibliography**

Freud, Sigmund. (1905d). Three essays on the theory of sexuality. *SE*, 7: 123–243.

———. (1911c). Psycho-analytic notes on an autobiographical account of a Case of paranoia (dementia paranoides). *SE*, 12: 1–82.

———. (1916–17a). Introductory lectures on psychoanalysis. *SE*, 15–16.

Freud, Sigmund, and Breuer, Josef. (1895d) *Studies in hysteria*. *SE*, 2.

### Further Reading

Greenacre, Phyllis. (1960). Regression and fixation. *Journal of the American Psychoanalytic Association*, 8, 703–723.

Nagera, Humberto. (1964). On arrest in development, fixation, and regression. *Psychoanalytic Study of the Child*, 19, 222–239.

## FLIESS, WILHELM (1858–1928)

Wilhelm Fliess, a German physician, was born October 24, 1858, in Arnswalde (Markbrandebourg) and died in Berlin on October 13, 1928. He came from a family of Sephardic Jews. His mother observed the orthodox rituals, a tradition her son did not follow. He had a brother who was stillborn and a sister, Clara, a year younger, who died of pneumonia when Wilhelm was twenty. His father was in the grain business and committed suicide when Wilhelm was nineteen years old. He never spoke of this suicide, neither to Freud—to whom he related a different version of the father's death—nor to his own children, who didn't discover the truth until after their own father's death.

Fliess studied medicine in Berlin; in 1883 he opened a practice as a general practitioner and then as an otorhinolaryngologist. The number of patients grew along with his fame. He traveled a great deal, most importantly to Paris, in 1886, a year before meeting Freud, whose lectures he attended in Vienna. This was the start of their friendship, which resulted in a lengthy correspondence from 1887 to 1902, reaching its peak in 1899. Fliess married a Viennese woman from among the circle of Josef Breuer's patients named Ida Bondy, and together they had several children: Robert (1895) who became a well-known psychoanalyst after his emigration to the United States, Pauline (1898), Conrad (1899), and a stillborn daughter in 1902. Freud was treated by Fliess and was his enthusiastic collaborator; the two men met approximately once a year.

Fliess initially thought there was a correlation between the genital organs and the nose, based on the

principle of what he called the reflex nasal neurosis. In May 1895, when his wife was pregnant with their first child, he had a revelation of the theory of periods as a solution to the question of when conception occurred and the determination of the sex of the child. From that moment on he began constructing his system, postulating a cosmic harmony governed by the solar cycles, measured in days and years, between personal, family, and social events, but also affected by the animal and plant kingdoms. All vital events are determined by two periods, a male period of twenty-three days, and a female period of twenty-eight days, which are transmitted from generation to generation, from mother to child. Added to this bisexual periodicity was the idea of bilateralism, which represents the imprint of the simultaneity of the two periods on the body, the left hand bearing the positive and negative qualities of the opposite sex. Freud was interested in several aspects of the theory but doubted the cohesion of the three features (biperiodicity, bisexuality, and bilateralism) that were essential for Fliess and its predictive nature, which Fliess viewed as a rejection. He experienced this as a kind of persecution and in 1900 began distancing himself from his friend although Freud was not fully aware of it.

Their final break occurred in 1906. At the same time as the appearance of his major work on the theory of periods, *The Course of Life*, Fliess wrote a scathing pamphlet, "Pour ma propre cause," in which he accused Freud of having served as an intermediary in the plagiarism of his work by two young Viennese authors, Hermann Swoboda and Otto Weininger, who each had appropriated half of his ideas.

After breaking with his friend, Freud destroyed all his letters from Fliess and developed a theory of paranoia based on these experiences, which he also applied to Daniel Paul Schreber. Having done so, he failed to take into account the fact that his friend's delusion had first appeared in 1895 and he had encouraged it even as he took comfort in it. It was almost a reversal of the accusation of plagiarism to the extent that Fliess copied nature through his unshaken conviction that the determination of periods mimics natural cycles.

Ignorance and the censorship of the relations between Freud and Fliess have contributed to a fabricated version of Freud's self-analysis as the mythic origin of psychoanalysis, which projects a later schema of standard analytic therapy onto the original discovery. Fliess was not the analyst of Freud's unconscious



desires, but he represented a kind of precursor of the subject assumed to have knowledge of biology, and in doing so helped combine Freud's desire to be an analyst with a future science (that both men would divide between them).

After his break with Freud, Fliess continued to devote himself to his medical practice, caring for several analysts (Alix Strachey and Karl Abraham among them), and writing numerous articles, always on the same subjects, which were anthologized in books. With Ivan Block and Ernst Haeckel, he was a member of the Berlin Medical Society for the Sexual Sciences and Eugenics. He died of intestinal cancer on October 13, 1928. He was eulogized as a great doctor from Berlin.

ERIK PORGE

*See also:* Bisexuality; Eckstein, Emma; Fackel (Die-); Freud: *Living and Dying*; *Freud's Self-Analysis*; Germany; Irma's injection, dream of; *On Dreams*; "Project for a Scientific Psychology, A"; Self-analysis; *Sex and Character*; Splits in psychoanalysis; Swoboda, Hermann; Weinger, Otto.

### Bibliography

- Abraham, Karl. (1991). Six lettres inédites à W. Fliess. A. Buffel, E. Porge. *Littoral*, 31–32, 247–257.
- Fliess, Wilhelm. (1977). *Les Relations entre le nez et les organes génitaux féminins présentées selon leurs significations biologiques* (P. Ach and J. Guir, Trans.). Paris: Le Seuil. (Original work published 1897)
- Freud, Sigmund. (1985c). *The complete letters of Sigmund Freud to Wilhelm Fliess 1887–1904*. (J. M. Masson, Trans.). Cambridge, MA: Belknap/Harvard University Press.
- Sulloway, Franck. (1979). *Freud: The biologist of the mind*. New York: Basic Books.

## FLIGHT INTO ILLNESS

The Freudian notion of a "flight into illness" should be understood in terms of symptom formation and the primary and secondary gains of illness. The symptom is regarded here as a secondary defense against unconscious conflict, having value as a compromise between a wish and a defense.

Early in his work, Freud discussed this kind of symptom in terms of a psychological conflict, leading to repression and followed by compromise formation: "one portion of the symptom corresponds to the

unconscious wish-fulfillment and another portion to the mental structure reacting against the wish" (1900a, p. 569). The concept of gain through illness helps clarify the concept of flight into illness. In a note on the Dora case, added in 1923, Freud mentioned that "The motive for being ill is, of course, invariably the gaining of some advantage" and, further on, "In the first place, falling ill involves a saving of physical effort; it emerges as being economically the most convenient solution where there is a mental conflict" (1905e, p. 43).

Thus, in the case of a hysterical attack, the flight into illness might serve what Freud calls the "primary gain." Aside from the hysterical crisis, Freud noted in 1926 that there are cases in which neurosis is the most harmless solution to a conflict and, from a social point of view, represents the most advantageous solution. For the neurotic, flight into illness is a favorable avoidance of an unsatisfactory reality, a form of self-defense in the struggle to survive. Freud also noted, along the same lines, the desire to remain ill.

Insights associated with flight into illness also operate outside the framework of neurosis and neurotic conflict. As early as 1894 Freud wrote: "One is therefore justified in saying that the ego has fended off the incompatible idea through a flight into psychosis" (1894a, p. 59). In the contemporary context, some authors consider somatic symptoms to be a system of defense and resolution, an avoidance in the face of tension of all kinds.

ALAIN FINE

*See also:* "Fragment of an Analysis of a Case of Hysteria" (Dora/Ida Bauer); Gain (primary and secondary); Somatic compliance.

### Bibliography

- Freud, Sigmund. (1900a). *The interpretation of dreams*. *SE*, 4–5.
- . (1905e [1901]). Fragment of an analysis of a case of hysteria. *SE*, 7: 1–122.
- . (1926d). Inhibitions, symptoms and anxiety. *SE*, 20: 75–172.

## FLOURNOY, HENRI (1886–1955)

Henri Flournoy, a Swiss medical doctor and psychiatrist, was born on March 28, 1886, in Geneva, where

he died on May 6, 1955. He was the son of Théodore Flournoy. One of his sisters, Ariane, married Raymond de Saussure. His son, Olivier, became a psychoanalyst in Geneva. Flournoy studied medicine in Geneva and then took internships in Berne, Warburg, Munich, and Baltimore (at Johns Hopkins University). During the Balkan War, from 1912 to 1913, he served as a Red Cross doctor. A man of insatiable curiosity from an early age, he developed an interest in heraldry, to which he became a devoted amateur.

In 1920 he became a privatdocent and lecturer in psychopathology at the University of Geneva. He was president of the Société genevoise de prophylaxie mentale (Geneva Society for Mental Prophylaxis) and of the Conseil de surveillance des aliénés (Supervisory Board for Mental Illness) for the canton of Geneva.

In 1922 he opened a psychiatric and psychoanalytic practice in Geneva. There were four phases to his psychoanalytic training: an initial series of twenty-six sessions with Carl Gustav Jung, a six-month analysis with Johan Van Ophuijsen in the Netherlands, a three-month analysis with Sigmund Freud in Vienna, and a final six-month analysis with Hermann Nunberg, also in Vienna.

He was a close friend of Charles Odier, Raymond de Saussure, and Princess Marie Bonaparte and played an important role in the Swiss Society for Psychoanalysis. He was an active, though unofficial, participant in establishing the acts of incorporation of the Paris Psychoanalytic Society. In 1933 he presided at the eighth Conférence des psychanalystes de langue française (Conference of Francophone Psychoanalysts).

He worked intermittently after 1939, many foreign patients (mostly from the League of Nations) having left Switzerland and local demand having fallen off because of the war climate. As a result, Flournoy concentrated increasingly on psychotherapy.

He was appointed an expert for providing women who intended to have abortions with advice consistent with current legal requirements. Flournoy expended considerable energy in demonstrating that mental distress is a sufficient, more than sufficient, justification for abortion and advocated legalizing it. This contributed greatly to his celebrity, or notoriety, well beyond the borders of Switzerland. It was also the origin of an extensive correspondence with various medical, psychological, and legal publications.

As a psychoanalyst, Flournoy contributed to the development of the young Swiss Society for Psychoanalysis and to the acceptance of psychoanalysis in Switzerland. In addition to his many articles, in 1949 he published *Erreurs et dignité de la pensée humaine*.

OLIVIER FLOURNOY

*See also:* Flournoy, Théodore; France; Société psychanalytique de Genève; Switzerland (French-speaking); Switzerland (German-speaking).

### Bibliography

Flournoy, Henri. (1920). Dreams on the symbolism of water and fire. *International Journal of Psycho-Analysis*, 1 (3), 245–255

———. (1922). Çiva androgyne: contribution à l'étude psychanalytique des principaux symboles et attributs d'une divinité hindoue. *Archives de psychologie*, 18.

———. (1932). Le caractère scientifique de la psychanalyse. *Revue française de psychanalyse*, 5 (2), 190–200.

———. (1949). *Erreurs et dignité de la pensée humaine*. Paris: Le Mont-Blanc.

---

## FLOURNOY, THÉODORE (1854–1920)

A medical doctor and professor of physiological psychology at the University of Geneva, Théodore Flournoy was born in Geneva on August 15, 1854, and died, also in Geneva, on November 5, 1920. He was the son of Alexandre Flournoy and Caroline Claparède, sister of the naturalist Édouard Claparède.

Interested in philosophy and religion, Théodore Flournoy spent time in Germany to familiarize himself with the philosophy of Immanuel Kant, whose work he later taught at the university. After becoming a medical doctor, he was appointed a professor of physiological psychology at the University of Geneva in 1891.

His studies of the medium Hélène Smith were turned into a book, *Des Indes à la planète Mars*, which caused a considerable sensation in psychological and parapsychological circles in Europe and the United States. In it he described the phenomenon of “cryptamnesia,” forgotten memories that reappear without being recognized by the subject, who believes they are new. These memories disappear because of their

association with childhood sexual emotions. These involve a “subliminal process capable of achieving a degree of complexity and extent comparable to the work of composition and reflection in the thinker or novelist.” They are “reminiscences or momentary returns to earlier phases, which have long since been forgotten and which, normally, should have been absorbed during the individual’s development instead of recurring in strange forms.”

Cryptamnesia is unconscious. “The unconscious possesses a marvelous ability for dramatization, personification, and psychological proliferation; it is endowed with a creative imagination.” Flournoy went on to claim that “The unconscious, [is a] submerged sphere from which our instinct for physical and moral preservation confusedly arise, our feelings about sex, about spiritual and physical shame, everything that is most obscure and the least rational in the individual.” Concerning dreams, he wrote “By rising up from our hidden source, by throwing light on the intrinsic nature of our unconscious emotions, by revealing our ulterior motives and the instinctive slope of our associations of ideas, the dream is often an instructive probe into the unknown layers that support our ordinary personality.”

Flournoy used these hypotheses to explain the supranormal or parapsychological phenomena he studied. They helped compensate for the obscurity and misery of everyday life, attempted to realize sexual desires arising from a forgotten childhood, and served as defenses against internal threats of madness.

Freud was writing about the process of infantile amnesia at the same time, and it is clear just how close Flournoy’s claims were to Freud’s position. However, unlike Freud, Flournoy does not mention repression or the return of the repressed—the concept that enabled Freud to conceive of a dynamic therapy—but limited himself to cryptamnesia, locating the path to consciousness in subliminal activity. Like his friends William James and Frederick Myers, Flournoy did not treat patients; these men were observers—though that did not prevent them from proposing hypotheses for acting on and modifying phenomena.

Concerning the principle of parallelism, Flournoy’s aims were diametrically opposite those of Freud. Both men excluded transcendence from their investigations, but Flournoy did so in the hope of discovering it, free of human taint, while Freud tried to eliminate it,

especially in postulating the existence of erogenous zones at the start of life and the death instinct at the end, hoping to see the reign of science govern the study of the mind.

In 1901 Flournoy, with his cousin Édouard Claparède, founded *Les Archives de psychologie*, a review that was later taken over by Jean Piaget. He corresponded with Ferdinand de Saussure, whom he knew personally, along with other well-known linguists. His son Henri and his grandson Olivier became psychoanalysts. His daughter, Ariane, married psychoanalyst Raymond de Saussure.

OLIVIER FLOURNOY

See also: *Archives de psychologie, Les*; Claparède, Édouard; Cryptomnesia; Flournoy, Henri; *Psychology of the Unconscious, The*.

### Bibliography

Flournoy, Olivier. (1986). *Théodore et Léopold: de Théodore Flournoy à la psychanalyse*. Neuchâtel: La Baconnière.

Flournoy, Théodore. (1890). *Métaphysique et psychologie*. Geneva: Georg.

———. (1900). *Des Indes à la planète Mars*. Paris: Le Seuil.

———. (1902). Nouvelles observations sur un cas de somnambulisme avec glossolalie. *Les archives de psychologie, I*.

———. (1911). *Esprits et médiums*. Geneva: Kundig and Fischbacher.

---

## FLOWER DOLLS: ESSAYS IN CHILD PSYCHOTHERAPY

In an article that appeared in the *Revue française de psychanalyse* in 1949, “Cure psychanalytique à l’aide de la poupée-fleur” (A Psychoanalytic Cure with the Help of a Flower Doll), Françoise Dolto described her experience with this green doll—which is often referred to as a marguerite doll—in the treatment of a child named Bernadette.

At the age of five Bernadette was already suffering from *anorexia nervosa*. She was vomiting up her meals and spoke in a monotone. She dragged her left leg and her hand was folded back over her forearm, the consequence of a hemiplegia. She played with toys that she constantly punished. In the course of the seventh session, she began to speak about the monkey inside her

that said bad things, and then hammered her tummy with her fists to make the monkey come out.

Françoise Dolto noticed the child's interest in flowers, particularly marguerites. When her mother said that the little girl liked neither her animals nor her dolls, Dolto responded: "Perhaps she'd like a flower doll?" Bernadette responded, "Oh, yes, yes, a flower doll!" Her mother was asked to make a faceless doll with no hands out of green material and to crown it with a marguerite.

In the eighth session, Bernadette came with her flower doll, which she had named Rosine. She said she was horrible and naughty. "Do you know why she's so naughty?" Bernadette whispered into the analyst's ear: "For her being naughty means being nice because she has an arm and a leg that don't work. Her way of being nice is hurting others. She's not naughty, but she's ill. You're going to treat her!" And the doll stayed with the analyst while the little girl went away quite happy.

When Bernadette arrived for her ninth session, she came with a teddy bear dressed as a human doll, and she looked after it tenderly so that it wasn't too hot. From the day she left the flower doll for treatment, Bernadette had changed at home. "I treated her every day, you know," Explained Dolto. Then Bernadette spoke quietly to her doll, listened to her answer, made her dance on the table, and suddenly cried out in a modulated voice: "She's cured, her arm and legs work very well! You looked after her very well." Then she thrust forward her folded-back hand, like a sort of claw. "She's a wolf girl, so when she loves she scratches! Because the wolf girl is very fond of you she's going to show you how strong she is!" She began to dig her nails into the analyst's skin, saying: "Don't be afraid, she has to see blood because she loves you."

From that session onward, Bernadette used her good right hand to stroke the other hand, and she began to create many objects with clay, and her behavior changed. Dolto theorized that the flower doll was the support for the girl's narcissistic affects, which were wounded during the oral stage. Afflicted with serious somatic disorders, this sick little girl's oral, then anal, aggression turned against herself, then projected itself into this human and plant form without a head, a form that was unable to speak and not responsible for its actions. Bernadette used it for her treatment, which gave Dolto the idea of using it with other children and adults.

BERNARD THIS

### Source Citation

Dolto, Françoise. (1949). Cure psychanalytique à l'aide de la poupée-fleur. *Revue française de psychanalyse*, 13 (1), 53–69.

———. (1950). À propos des poupées-fleurs (deuxième partie). *Revue française de psychanalyse*, 14 (1), 19–41.

———. (1998). *Flower dolls: Essays in child psychotherapy*. (John Howe, Trans.). London: Marion Boyars.

---

## FLÜGEL, JOHN CARL (1884–1955)

The English psychoanalyst John Carl Flügel was born on June 13, 1884, in London, where he died on August 17, 1955. An honorary fellow of the British Psychological Society and an honorary member of the Indian Psychological Association, he was president of the Programme Committee of the International Congress on Mental Health in 1948 and president of the psychology section of the British Medical Association in 1950.

His father was German and his mother English, and the family had close ties with France; John Carl grew up learning all three languages. Because of a congenital malformation of his feet, he did not follow a normal school program, and he attended Oxford University when he was only seventeen. He studied philosophy and grew interested in hypnotism, becoming a member of Frederick W. H. Myers's famous Society for Psychical Research. He obtained a doctorate in philosophy at Oxford and a doctorate of science from the University of London, where he taught as an auxiliary professor from 1929 to 1944 in the experimental psychology laboratory. In 1913 he married Ingeborg Klingberg, who also became a psychoanalyst and with whom he had a daughter.

Flügel was an active member of the British Psychological Society: he was honorary secretary from 1911 to 1920, honorary librarian from 1911 to 1932, and president from 1932 to 1935. During the First World War he made a number of important psychological contributions to the society. After undergoing psychoanalysis with Ernest Jones, the two became friends, and Flügel became involved in the refounding of the British Psycho-Analytical Society in 1919. He also served as secretary of the International Psychoanalytic Association from 1919 to 1924. With John Rickman, Douglas Bryan, and Ernest Jones, he helped create the *International Journal of Psychoanalysis* in 1920, and with Ernest Jones and Joan Riviere, he helped translate

Sigmund Freud's *Vorlesungen (Introductory Lectures on Psycho-Analysis; 1916–1917a [1915–1917])*.

His knowledge of biology, experimental psychology, and philosophy, and his involvement in psychoanalysis enabled him to produce a considerable number of literary works, although these works are rarely read in the early twenty-first century. Ernest Jones wrote to Freud, "Flügel is certainly not predisposed to self-sacrifice, but what he does, he does very well and he is our best report writer. In non-medical circles he is of inestimable value and always uses his influence for the PAS [Psycho-Analytical Society]" (April 10, 1922). He wrote many books and articles, including *The Psycho-Analytic Study of the Family* (1921), which was the third volume (but the first English contribution) in the then recently created International Psycho-Analytical Library of Hogarth Press; "Psychoanalysis: Its Status and Promise" (1930a); *The Psychology of Clothes* (1930b); and *Man, Morals, and Society* (1945).

Upon Flügel's death, Ernest Jones wrote of his "good nature, kindness, humor, and fondness for an exceptionally large circle of good friends." Jones was less charitable, however, in a letter to Freud dated December 7, 1921: "Flügel has excellent written English and is intelligent, but he has two weaknesses. He is somewhat egotistic and the only thing he enjoys is doing his own work, not helping others; and he has not overcome a strong reaction to a sadistic complex that has paralyzed his efforts to criticize or disagree in any way, with very rare exceptions. He is thereby inhibited when he is asked to carry out any work of this sort (the same holds true for the correction of the American translation of the *Vorlesungen*), and he returned the manuscript almost in the same condition as it was. A mixture of laziness and inhibition. But he has to work with the tools available to him and I am trying to find out what interests him most and what is most suitable for him (which is to say, not much)."

ALAIN DE MIJOLLA

See also: Great Britain.

### Bibliography

Flügel, John Carl. (1921). *The psycho-analytic study of the family*. London: Hogarth and the Institute of Psycho-Analysis.

———. (1930a). Psychoanalysis: Its status and promise. In Carl Murchison (Ed.), *Psychologies of 1930*. Worcester, MA: Clark University Press.

———. (1930b). *The psychology of clothes*. London: Hogarth Press.

———. (1945). *Man, morals, and society*. New York: International Universities Press.

Freud, Sigmund, and Jones, Ernest. (1993 [1908–1939]). *The complete correspondence of Sigmund Freud and Ernest Jones, 1908–1939*. Cambridge, MA: Harvard University Press.

Jones, Ernest. (1956). J. C. Flügel. *International Journal of Psycho-Analysis*, 37, 193–197.

---

### FLUSS, GISELA (1859–?)

Gisela Fluss, born on September 26, 1859, was the daughter of Ignaz and Eleonora Fluss, a family friendly with Jakob and Amalia Freud after the Freuds left Freiberg, Moravia. She was the sister of Emil Fluss, who became a friend and correspondent of Freud during his adolescence. She is known as Freud's first "love experience." The date of her death is not known.

Gisela met Freud when he was staying with the family in 1871. Gisela appears to have been associated with the romantic infatuation that had gripped the fifteen-year old Freud—Gisela was only twelve—during his return to his birthplace, an infatuation that Freud cryptically referred to in "Screen Memories" (1899a).

When he was again in Freiberg the following year, Freud mentioned Gisela in letters describing his vacation written to his friend Eduard Silberstein (1989a [1871–1881, 1910]). On August 17, 1872, he wrote, "So let me just say that I took a fancy to the eldest, by the name of Gisela, who leaves tomorrow, and that her absence will give me back a sense of security about my behavior that I have not had up to now." On September 4 he again wrote to Silberstein: "I have soothed all my turbulent thoughts and only flinch slightly when her mother mentions Gisela's name at table. The affection appeared like a beautiful spring day, and only the nonsensical Hamlet in me, my diffidence stood in the way of my finding it a refreshing pleasure to converse with the half-naïve, half-cultured young lady."

In fact, these letters show that the young Freud harbored greater enthusiasm for Eleonora, Gisela's mother, "a woman none of her children can completely equal." In the letter of September 4, Freud went on to write, "She [the mother] can never have been beautiful, but a witty, jaunty fire must always have sparkled in her eyes, as it does now. Gisela's beauty, too, is wild,

I might say Thracian: the aquiline nose, the long black hair, and the firm lips come from the mother, the dark complexion and the sometimes indifferent expression from the father.”

Allusions to Gisela appeared in letters from 1873 and 1874 but disappeared after Gisela told Freud's sisters, in 1875, of a trip to Italy. Her engagement in 1874 and her being called an ichthyosaur by students among themselves remain in dispute. It is known, however, that on February 27, 1881, in Vienna, she married a businessman from Presbourg (near Bratislava) by the name of Emil Popper.

There is some mystery about her reappearance in Freud's report of his November 18, 1907, session with the Rat Man, when, instead of the name of his patient, Freud wrote her name “Dame Gisela” (1955a [1907–1908]). He added three exclamation points after this slip, which was never analyzed by Freud and has remained unexplained.

ALAIN DE MIJOLLA

See also: Silberstein, Eduard.

### Bibliography

- Freud, Sigmund. (1899a). Screen memories. *SE*, 3: 299–322.
- . (1955a [1907–1908]). Notes upon a case of obsessional neurosis. *SE*, 10: 151–318.
- . (1989a [1871–1881, 1910]). *The letters of Sigmund Freud to Eduard Silberstein, 1871–1881* (Arnold J. Pomerans, Trans.). Cambridge, MA: Belknap Press, 1990.

## FORECLOSURE

Jacques Lacan used the French word *forclusion* (foreclosure) to translate the German term *Verwerfung*, previously rendered in French as *rejet* (repudiation). Sigmund Freud had introduced the term along with negation (*Verneinung*) and repression (*Verdrängung*) as a defense mechanism.

Foreclosure is a primordial defense because it does not act on a signifier that is already inscribed within the chain of signifiers, but rather, it rejects the inscription itself. Foreclosure is thus antithetical to *Bejahung* (affirmation).

This operation of repudiation especially affects highly meaningful signifiers such as the Name-of-the-Father,

the guarantor of castration. Lacan viewed the foreclosure of this signifier as the characteristic mechanism of psychosis. In “On a Question Prior to any Possible Treatment of Psychosis” (*Écrits*), he wrote: “I will thus take *Verwerfung* to be foreclosure of the signifier. At the point at which the Name-of-the-Father is summoned—and we shall see how—a pure and simple hole may answer in the Other; due to the lack of the metaphoric effect, this hole will give rise to a corresponding hole in the place of phallic signification” (p. 191). To paraphrase, let us say that when the subject calls upon the Father to guarantee the law that situates both the subject and his desire in the Other, he encounters only an echo in a void that triggers a cascade of delusional metaphors. These readily become organized around the fantasmatic presence of an authority who is suspected of having intrusive or criminal intentions; it is as if the foreclosure of the Name-of-the-Father made present in the Real a malevolent authority desiring to commit sexual abuse or homicide.

Why does foreclosure come about? One explanation is that the child has been exposed to a mother who has refused to recognize the law, either because it does not situate her in accordance with her desires, or because it compels her to separate herself from its product. It may also happen that the real father reveals himself to be incapable of inscribing himself into a symbolic lineage, and consequently invalidates it (cf. Schreber's father in “Psycho-Analytic Notes on an Autobiographical Account of a Case of Paranoia [Dementia Paranoides],” 1911c). But not infrequently, skipping a generation, the child of a psychotic couple may validate the Name-of-the-Father on its own, based on what he finds in language and verifies with the help of substitute parent figures.

Could specific forms of foreclosure be responsible for the division of the psychoses into paranoia and schizophrenia? Nothing points to this conclusion, even if paranoia is an attempt at a cure through the designation of a real, albeit a persecutory father. This designation turns the signifier into a sign of certain truth.

Many have asked whether psychoanalytic treatment can repair a foreclosure. Case histories do not provide any clear answers.

Let us recall that Schreber, for his part, found a kind of stabilizing by accepting emasculation as being “consonant with the Order of Things” (p. 48); by becoming a woman, he could attract the divine presence that

safeguarded him. Equally interesting are studies of borderline cases. It seems that the latter more likely result from a denial or annulment of the Name-of-the-Father, with a predictable failure of the law, but without producing the reshaping of the real (its fragmentation or its investment by a persecutory figure) that are characteristic of foreclosure.

CHARLES MELMAN

*See also:* Autism; Castration complex; Parade of the signifier; Disavowal; Infantile neurosis; Law of the father; Linguistics and psychoanalysis; Negative, work of the; Negation; Neurosis; Psychoses, chronic and delusional; Psychotic defenses; Real, the (Lacan); Repudiation; Splitting; Topology.

### **Bibliography**

Freud, Sigmund. (1894a) Obsessions and phobias: Their psychological mechanism and their aetiology. *SE*, 3, 69–82.

———. (1911c) Psycho-analytic notes on an autobiographical account of a case of paranoia (dementia paranoides). *SE*, 12, 1–82.

Lacan, Jacques. (2004). On a question prior to any possible treatment of psychosis. *Écrits: A Selection* (Bruce Fink, Trans.). New York: W. W. Norton. (Original work published 1955–56)

## **FORGETTING**

In *The Psychopathology of Everyday Life* (1901b), Freud discussed forgetting under the rubric of psychosis. The typical example is awareness of having forgotten a proper noun (a name, for example). Like amnesia (where one is unaware that one has forgotten), forgetting is the result of repression. The forgotten name inhabits the preconscious and quickly returns to consciousness. It is attracted by an unconscious mental complex that primarily operates by displacement.

The concept of forgetting in general is present in Freud's earliest works on the theory of neuroses (1894a, 1895b, 1896a). But in "*The Psychological Mechanism of Forgetfulness*" (1898b) and *The Psychopathology of Everyday Life*, Freud considered forgetting, like slips of the tongue, to be a parapraxis symptomatic of ongoing repression. To demonstrate the existence of the unconscious, Freud uses the example of forgetting because it was one way of talking about repression before 1900. Forgetting appears in his first theory of neuroses, which explains hysteria as a traumatic

infantile sexual seduction that has to be rejected and repressed because the child finds it unacceptable.

Forgetting is associated with a painful sense of awareness (the "name on the tip of the tongue"), while repression is most often unconscious. Forgetting is associated with the psychology of consciousness and the preconscious, while repression is associated with the metapsychology of the unconscious, like memory traces. As a form of parapraxis, forgetting combines partial failure with partial success and must be distinguished from the customary psychological form of forgetting, a successful act of repression.

The dreamer who has forgotten his dream tries to reconstruct it, but in doing so, constructs it anew: "It is indeed possible that while trying to retell it, we fill in the blanks created by forgetting using new material arbitrarily chosen" (Freud, 1900a). We cannot completely remember what is forgotten, and so we prefer to construct likely hypotheses, capable of introducing conviction about what was forgotten (Freud, 1937d).

The person who has forgotten a name, by concentrating on it, only reinforces the ongoing repression. To remember, Freud tells us, we need to abandon the willful attempt to control what initially appears to be a cognitive disturbance, a shortcoming, and give in to the associations that come to mind.

Freud provides an autobiographical example: Forgetting the name of the painter Signorelli during a conversation, he seeks memories, ideas, and words similar to the name. These bring to his mind other paintings with the sensory acuity typical of a screen memory (an early memory used as a screen for a later event), along with the names of other Italian painters (Botticelli, Boltraffio). The value that Freud attributed to the forgotten name had been transferred to neighboring elements, through displacement, as is the case with a mnemonic symbol, which is also a form of metonymy. "Botticelli" is a metonym of Signorelli, "Botticelli" and "Boltraffio" are metonyms of Bosnia-Herzegovina, which Freud was visiting when he forgot Signorelli's name and which is related to the castration complex involved in this forgetting, since Freud attributes to the Turks in Bosnia-Herzegovina a strong attraction to sexuality and a considerable castration anxiety. "Boltraffio" was a metonym of Trafoi, an Italian city where Freud learned of the suicide of one of his patients, which triggered his thoughts on "death and sexuality." The sentence "Herr, was ist da zu

sagen? (Sir, what is there to say)” reported to Freud by his interlocutor as reflecting the Turks’ attitude toward the inevitability of death, evoked their attitude toward sexuality (“You know very well, Lord, if that fails, then life has no value”), the source of psychic conflict and repression behind his act of forgetting. The representation of death Freud associated with that of castration (the Turkish sentences imply that a life without sexuality is worth no more than death). Moreover, *Herr*, present in Herzegovina, refers to *Signor* (Lord), to the father figure, and to *Herz*, the heart, an organ likely to grow sick and cause death. Forgetting the name of Signorelli is thus associated with an oedipal dimension that Freud had discovered through his self-analysis: his repression of sexuality, his attraction for his mother, his rivalry with his father, and his ambivalent identification with his father caught up in a desire for parricide and a fear of losing his father.

Freud analyzed two levels at the same time, the psychology of consciousness and the preconscious and the metapsychology of the unconscious. He thus provided an example of the psychoanalytic method, although repression is not associated with the name “Signorelli” so much as the unconscious complex he represents. The names substituted for the forgotten name are composed of verbal memory traces and other proper nouns. They are substituted for the forgotten name through a process that acts on the phonemic material of words (the signifier) through association, metonymy, homology, as well as translation from one language to another, metaphor, and polysemy (*Herr* has multiple meanings, as does *Herz*). In the process of forgetting the name, displacement is metonymy, and condensation is metaphor.

Forgetting, like remembering, belongs more to the phenomenology of consciousness than to the metapsychology of the unconscious. As a specific form of parapraxis, it also signifies repression according to popular convention. Because it occurs in the preconscious and is attracted by the unconscious, forgetting and the rediscovery of the forgotten are similar to what occurs when the subject clearly formulates for himself something he had always known. There have been few developments in psychoanalysis concerning the preconscious ego. As a result, it is easier to formulate psychoanalytic approaches that emphasize the cognitive causality of forgetting.

FRANÇOIS RICHARD

*See also:* Amnesia; Cryptomnesia; Déjà-vu; *Delusions and Dreams in Jensen’s “Gradiva”*; Formations of the unconscious; Memory; *Moses and Monotheism*; Mythology and psychoanalysis; Slips of the tongue; “Remembering, Repeating, and Working-Through”; Reminiscence; Repression; *Psychopathology of Everyday Life The*.

### Bibliography

- Freud, Sigmund. (1894a). The neuro-psychoses of defence. *SE*, 3: 41–61.
- . (1895b). On the grounds for detaching a particular syndrome from neurasthenia under the description “anxiety neurosis.” *SE*, 3: 85–115.
- . (1896a). Heredity and the aetiology of the neuroses. *SE*, 3: 141–156.
- . (1898b). The psychical mechanism of forgetfulness. *SE*, 3: 287–297.
- . (1900a). The interpretation of dreams. *SE*, 4: 1–338; 5: 339–625.
- . (1901b). The psychopathology of everyday life. *SE*, 6.
- . (1937d). Constructions in analysis. *SE*, 23: 255–269.

### Further Reading

- Bach, Sheldon. (2001). On being forgotten and forgetting one’s self. *Psychoanalytic Quarterly*, 70, 739–756.

## FORMATIONS OF THE UNCONSCIOUS

Dreams, the forgetting of words and names, slips of the tongue, parapraxes in general, and jokes are all examples of formations of the unconscious, the forms by which the unconscious expresses itself. *The Formations of the Unconscious* is also the title of Jacques Lacan’s fifth seminar, given in 1957–1958. The expression also establishes, as a distinct group, different symptoms that were all discussed by Freud in his earliest works.

These formations of the unconscious are, in fact, symptoms, insofar as they are an expression and fulfillment of an unconscious wish. In psychoanalysis, they constitute the royal road to the unconscious. But knowledge of the unconscious can only be hypothesized, because “it is only as something conscious that we know it, after it has undergone transformation or translation into something conscious” (Freud, 1915e, p. 166). By proposing a generic expression for the symptomatic elements that Freud listed, Lacan emphasized that as “overdetermined” and “structurally iden-



tical” elements, they are “only conceivable, strictly speaking, within the structure of language” (Lacan, 2004a/1958, p. 260).

Freud isolated two principle mechanisms at work in the process of unconscious formations: condensation and displacement. Lacan suggested redefining these mechanisms as “the two aspects of the signifier’s effect upon the signified” (Lacan, 2004b/1957, p. 152), namely *metaphor* and *metonymy*, terms that had been analyzed by the linguist Roman Jakobson.

The notion of formations of the unconscious is related to Freud’s ideas of substitute formation, the return of the repressed, and symptom-formation.

ALAIN VANIER

*See also:* Graph of Desire; Metaphor; Object *a*; Over-interpretation; Seminar, Lacan’s; Splitting of the subject; Subject of the unconscious; Substitutive formation.

### **Bibliography**

- Freud, Sigmund. (1900a). The interpretation of dreams. *SE*, 4: 1–338; 5: 339–625.
- . (1901b). The psychopathology of everyday life. *SE*, 6.
- . (1905c). Jokes and their relation to the unconscious. *SE*, 8: 1–236.
- . (1915e). The unconscious. *SE*, 14: 159–204.
- Lacan, Jacques. (1998). *Le séminaire*. Book 5: *Les formations de l’inconscient, 1957–1958*. Paris: Seuil.
- . (2002a). The direction of the treatment and the principles of its power. In his *Écrits: A selection* (Bruce Fink, Trans., pp. 215–270). New York: W. W. Norton. (Original work published 1958)
- . (2002b). The instance of the letter in the unconscious, or reason since Freud. In his *Écrits: A selection* (Bruce Fink, Trans., pp. 138–168). New York: W. W. Norton. (Original work published 1957)

## **FORNARI, FRANCO (1921–1985)**

Franco Fornari, an Italian surgeon, psychiatrist, and psychoanalyst, was born in Rivergaro, Piacenza, on April 18, 1921, and died in Milan on May 20, 1985. A student and analysand of Cesare Musatti, Fornari went on to become president of the Società psicoanalitica Italiana (Italian Psychoanalytic Society) and director

of the Psychology Institute of the Department of Literature and Philosophy at the State University of Milan.

Fornari introduced the ideas of Melanie Klein to Italy. In his early writings, to treat schizophrenia and depression he advocated deepening our understanding of the primal psychotic dimension by examining the mental development of the child’s affective life. He also studied group dynamics and social conflict, his research on these subjects appearing in an essay titled *Nuovi orientamenti nella psicoanalisi* (New directions in psychoanalysis; 1966).

Fornari’s Kleinian convictions are most apparent in his wartime research, which gave rise to several interesting psychological studies, including *The Psychoanalysis of War* (1974). In this work Fornari located the anxieties and psychotic fantasies that govern the behavior of individuals in groups, and he revealed the ensuing loss of responsibility in various social and political situations. War, he said, arises from the external projection of an internal danger and the negation of death in the face of an alleged external persecutory entity, and these forces make the individual destroy to survive.

Fornari then investigated the theme of sensuality in relation to affective symbolization. In *Genitalità e cultura* (Genitality and culture; 1975), he examined the notion of perversion, determining that culture is the antithesis not of sensuality but of pregenitality, which arises from a lack of infantile symbolization and from destructive impulses dominating in one’s behavior. He subsequently proposed an evolutionary reading of libidinal development.

Though elements of symbolization are already present in *Genitalità e cultura*, Fornari directly studied this topic in *Simbolo e codice* (Symbol and code; 1976), *I fondamenti di una teoria psicoanalitica del linguaggio* (Foundations of a psychoanalytic theory of language; 1979) and *Codice vivente* (Living codes; 1981). In these essays Fornari reexamined psychoanalytic theory in cognitive terms, establishing the foundation for a psychoanalytic anthropology that could also be of use to nonpsychoanalysts. He resolved the relation between body and mind by positing a code that preserves and transmits information in both directions between body and mind. Such a code, which he called the “living code,” is assumed in the programming of affects, which in fact is driven by one’s erotic materiality and parental bonds. Fornari developed a “coinemic” theory, in which the minimum unit of affective meaning is the “coineme.” Fornari saw this living code as an

instrument and methodology that could be used to apply psychoanalysis to a broad range of cultural phenomena: speech, images, behavior.

In *La riscoperta dell'anima* (The rediscovery of the soul; 1984), Fornari attempted to understand the human effort to rediscover the primal symbiotic unity with one's mother. And in *Affetti e cancro* (Affects and cancer; 1985) he investigated the role that psychoanalysis could play in treating incurable diseases.

GIANCARLO GRAMAGLIA

See also: Italy.

### Bibliography

Fornari, Franco. (1966). *Nuovi orientamenti della psicoanalisi*. Milan: Feltrinelli.

———. (1974). *The psychoanalysis of war* (Alenka Pfeifer, Trans.). Garden City, NY: Anchor Press. (Original work published 1970)

———. (1975). *Genitalità e cultura*. Milan: Feltrinelli.

———. (1976). *Simbolo e codice: dal processo psicoanalitico all'analisi istituzionale*. Milan: Feltrinelli.

———. (1979). *I fondamenti di una teoria psicoanalitica del linguaggio*. Torino: Boringhieri, 1979.

———. (1981). *Il codice vivente: femminilità e maternità nei sogni delle madri in gravidanza*. Torino: Boringhieri, 1981.

———. (1984). *La riscoperta dell'anima*. Bari: Laterza.

———. (1985). *Affetti e cancro*. Milan: Cortina.

## FORT-DA

“Fort!” and “Da!” are exclamations that Sigmund Freud heard his grandson Ernst utter while playing. This pair of words—meaning “Gone!” and “There!”—has become shorthand for repetition in early childhood, and for the primary processes that such behavior mobilizes.

In psychoanalysis, allusions to *fort/da* refer to the second chapter of *Beyond the Pleasure Principle*, where in a few celebrated pages Freud described and interpreted a game played by the little Ernst at the age of eighteen months. At the time, Freud was tackling the thorny problem of the compulsion to repeat in traumatic neurosis, and this digression into normal childhood experience was in fact meant to help contextualize the question. Ernst was a “good little boy,”

manifested no particular symptoms, was rather calm by disposition, and “never cried when his mother left him for a few hours.” But he “had an occasional disturbing habit of taking any small objects he could get hold of and throwing them away from him into a corner, under the bed. . . . As he did this he gave vent to a loud, long-drawn-out ‘o-o-o-o,’ accompanied by an expression of interest and satisfaction. His mother and the writer of the present account were agreed in thinking that this was not a mere interjection but represented the German word ‘fort.’” Freud interpreted this behavior as a way of obtaining satisfaction by causing things to be “gone.” A short time later he observed the child playing with a reel that had a piece of string tied around it: He would toss the reel away from him to where it could no longer be seen, before pulling it back into view and hailing its reappearance with a gleeful “Da!” (“There!”). Freud also noticed that the boy would utter his “o-o-o-o” sound with reference to *himself*—notably when, by crouching down below a mirror, he made his image “gone.” Freud stresses the fact that the *fort* part of the game was much of the time sufficient unto itself, and was “repeated untiringly” by the child (1920g, pp. 14–15).

This observation leads to a number of fundamental questions: Are we confronted here by a method of mastering a painful experience by reproducing it oneself in an active manner, as children so often do, for example when playing frightening games? Or is the child literally taking revenge for the treatment visited upon him by redirecting it onto the other, or onto himself? In the end, the answer is not of any great consequence, for the real problem is the contradiction, which here is seen to arise very early, between the compulsion to repeat and the pleasure principle. How is it that satisfaction is to be derived from repeating actions that have been sources of unpleasurable feelings?

The great interest of this discussion of Freud's is that it sums up and condenses his subsequent exploration of the issue of the repetition compulsion. This very early children's game shows this compulsion to be one of the fundamental processes of the psyche, with two enigmatic aspects, one making manifest “mysterious masochistic trends” that resist all attempts at analysis (p. 14), the other revealing an irreducible primordial violence that takes an especially virulent form, according to Freud's account, when little Ernst, at thirty months, throws aside a toy and unequivocally identifies it with his absent father who has been “sent to the front” (p. 16).

The *fort/da* game has inspired very many authors who have seen it as the embodiment of the institution of fundamental structures of the infantile psyche, though their emphasis varies according to tendency or school. Thus Melanie Klein and Donald Winnicott both drew a number of lessons from it as they sought to cast light on the origins of the child's mental life and develop play techniques for use in child therapy. For Jacques Lacan, the game expressed the child's accession to the symbolic order, and the purpose of making something appear and disappear was to replace it with elementary signifiers. Jean Laplanche, for his part, sees this play as the first attempt to respond to the adult's enigmatic messages.

It must be noted that Freud's original discussion actually focused in turn on first one and then another game, each dominant at a different moment. The first, at eighteen months, is based on *fort*, on throwing the object far away, with the accompanying "o" sound, and it indicates the pleasure obtained from making the other disappear, or making oneself disappear, a pleasure that makes it possible to tolerate absence and reflects the violence that absence implies; this game endures, for it is still available when, at thirty months, Ernst is gratified by his father's going off to war. The second game is founded on disappearance and reappearance, and shows a quite different kind of pleasure, that felt by the child when he sees what he had thought gone forever return from the void, and thus discovers the possibility of permanence, of continuity—the necessary basis for introjection and the working out not only of the symbolic order but also of the imaginary one. As much as the first game, if it is associated with nothing else, is governed by death-dealing repetition, the second, by contrast, is connected to a constructive repetition and partakes of a process of binding and transformation.

It is thus the *fort* game that is the more problematical, in that the subject obtains from the disappearance of the other or of himself an unconscious gratification which runs counter to the most fundamental prohibitions. In view of his belief in the omnipotence of thoughts, the child cannot conceive of death or disappearance otherwise than as the outcome of a wish; he can form an idea of these concepts solely through seeing and losing sight of objects, so he links these to the deployment of visual desire, thereby transforming trauma into pleasure, albeit a forbidden pleasure. In his account of *fort/da* play, Freud hints that the game

was beneficial to Ernst, for, even though he was not free from feelings of jealousy upon the arrival of a new sibling, he was well able to cope with the death of his mother a short time later. This was not to say, however, as Freud had noted in discussing "dreams of the death of persons of whom the dreamer is fond" (1900a, pp. 248ff), that once the subject reaches adulthood, and becomes aware of the true meaning of death, they will not be assailed in a deferred way by the guilt-driven anxiety that is to be seen in so many neuroses.

GÉRARD BONNET

*See also:* *Beyond the Pleasure Principle*; Childhood; Death instinct (Thanatos); Infant observation (direct); L and R schemas; Lost object; Metaphor; Object *a*; Symbolic, the (Lacan); Symbolization, process of; Word-presentation.

### **Bibliography**

Freud, Sigmund. (1900a). The interpretation of dreams. Part I, *SE*, 4: 1–338; Part II, *SE*, 5: 339–625.

———. (1920g). *Beyond the pleasure principle*. *SE*, 18: 1–64.

---

## **FOULKES (FUCHS), SIEGMUND HEINRICH (1898–1976)**

Physician and psychoanalyst Siegmund Heinrich Foulkes was born on September 1898 in Karlsruhe, Germany, and died on July 8, 1976 in London.

He was the youngest child of a comfortably-off, assimilated Jewish family (the Fuchs). After service in the telephone and telegraph section of the German army in World War I, he studied medicine at Heidelberg, qualifying at Frankfurt.

Foulkes soon determined to become a psychoanalyst but first spent two significant years as an assistant to the neurologist Kurt Goldstein. The work centered on rehabilitation of brain-damaged soldiers from World War I, who were intensively studied neurologically and with methods derived from Gestalt psychology by Adhemar Gelb. Goldstein's holistic approach to the function of the central nervous system later influenced Foulkes's concept of the group: as a whole where each person represents a nodal point in the group's network, analogous to the function of the neurone in the cortical network of the central nervous system.

In 1928 Foulkes went to Vienna for psychoanalytic training and postgraduate psychiatry. His analyst was Helene Deutsch and his supervisors Eduard Hitschmann and Herman Nunberg. Paul Schilder was also a significant influence. His close friend was Robert Waelder.

In 1930 Foulkes returned to Frankfurt as director of the outpatient clinic of the newly founded Frankfurt Psychoanalytic Institute directed by Karl Landauer. Erich Fromm and Frieda Fromm-Reichman were colleagues. There were fruitful exchanges in Frankfurt between psychoanalysts and sociologists, as both the Psychoanalytic Institute and the Sociological Research Institute (led by Theodor Adorno and Max Horkheimer) shared the same building. Foulkes developed a close friendship with the sociologist Norbert Elias whose theories were influential in his later group analytic theories. During this time he also became acquainted with the American analyst Trigant Burrow's writings on group analysis.

Foulkes emigrated to England in 1933. After psychoanalytic practice in London he moved to the provincial town of Exeter, where he first began group psychotherapy. He further developed group work in the British Army, notably at Northfield Military Hospital where he collaborated with Thomas Forest Main, Harold Bridger and others. Foulkes was the principal architect in transforming the hospital to a therapeutic community. Wilfred Bion and John Richman had preceded him in their short experiment in group work. In 1948 Foulkes published his Northfield experiences in his first book where he laid down the bases of group analytic theory and practice.

After the war Foulkes was a training analyst for the Anna Freud Group in the British Psychoanalytic Society and Consultant Psychotherapist at the Maudsley Hospital where he taught generations of psychiatrists the rudiments of both individual and group psychotherapy. With James Anthony he founded the Group Analytic Society and later collaborated in forming the Institute of Group Analysis, both in London.

Foulkes's approach is that of "psychoanalysis by the group"—developing the group members' therapeutic capacities as co-therapists to each other, in contrast to the approaches of Wilfred Bion and Henry Ezriel's "psychoanalysis of the group," or Franz Alexander and Alexander Wolf's "psychoanalysis in the group."

His principal contributions, as described in his book *Therapeutic Group Analysis* (1964) are the Matrix and the therapeutic power of mirroring. The Matrix is the hypothetical basis of all group transactions that provides the group's capacity for containment and holding. Mirroring and resonance are the group's specific therapeutic factors. The value of communication is a vital therapeutic factor as well: the ability to translate the language of symptoms into articulate, exchangeable communications. The therapist's main contribution is to facilitate this process. Foulkes valuably emphasizes the therapist's responsibility to be the "dynamic administrator," organizing and protecting the group situation, as well as his responsibilities as group conductor. Foulkes died during a seminar he was leading for his senior colleagues.

MALCOLM PINES

*See also:* Great Britain; Group analysis; Group psychotherapy; Sigmund Freud Institute; Tavistock Clinic.

### **Bibliography**

Foulkes, Siegmund Heinrich. (1964). *Therapeutic group analysis*. New York: International Universities Press.

---

## **FOUR DISCOURSES**

In his seminar "The Other Side of Psychoanalysis," Jacques Lacan introduced four types of discourses. The discourses are the discourse of the master, the discourse of the hysteric, the discourse of the university, and the discourse of the analyst. They represent a matrix in which everything comes in fours. The discourses too are made up of four elements: S1, the master signifier; S2, knowledge; *a*, surplus enjoyment; and  $\$$ , the subject. Their positions above and below the bar on either side of the diagram represent four different values or functions: the agent, the other, the production, and truth.

In this fourfold structure, manipulating the minimal signifying chain, S1→S2, is both necessary and sufficient to represent the subject,  $\$$ , in relation to both the big Other (the unconscious) and the small other (the object *a* as the object cause of desire) (Fig. 1).

FIGURE 1

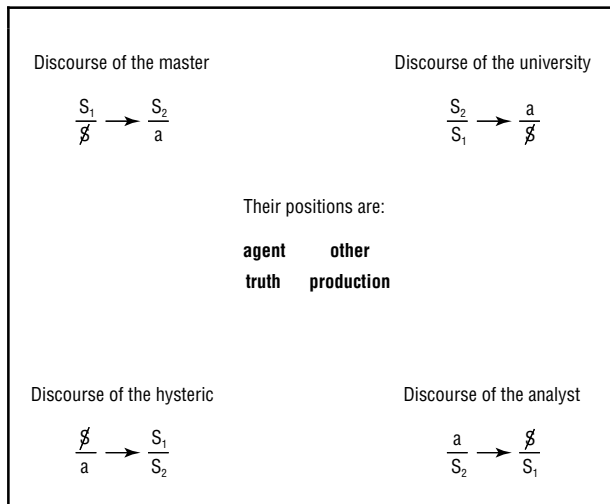

In each discourse, the *agent* addresses an *other*, and the *truth* that the discourse seeks is attained through a certain *production*. Insofar as there is a connection between S1 and S2, between the master-signifier and knowledge—a connection that depends on the essential mediation of speech—the subject is separated from the production of the discourse, and this results in a discourse that is always inadequate. In this case an unbridgeable gap separates the subject \$ and the object *a*.

If we take the discourse of the master as the starting point, the four terms generate each of the other discourses by making four successive ninety-degree turns in a clockwise direction. As each term takes the place of the agent, it assumes the dominant position and gives meaning and value to the discourse it generates. S1, the master-signifier, in the dominant position gives rise to discourse of the master. S2, knowledge, in that position produces discourse of the university. \$, the subject, as agent leads to discourse of the hysteric. In this case, the symptomatic signifier affects and marks the subject so that the subject's body displays the symptom and speaks metaphorically in the place of the repressed signifier. And finally, *a*, the object of desire, in the dominant position produces discourse of the analyst. But it is not because analysis is the “science of desire” that the analyst has direct access to the object *a*. If the analyst can assume the place of the agent and thus to know something about the patient's desire, it is only because the analyst is not duped into believing the agent's discourse. Something of the truth of the patient's desire has a chance to emerge within the framework of the treatment through the transference and by means of interpretation.

These four different social bonds constitute what Lacan claims is an essential support for communication. The four discourses go beyond speech, but “without going beyond language's actual effects” (Lacan, 1998, p. 93).

In the 1960s Lacan theorized the four discourses on the basis of a minute study of the social field that each discourse both reveals and conceals, because he wanted to ensure the transmission of psychoanalysis. He certainly knew that the discourses of the master and the university had existed for a much longer time. He credited Freud with having discovered the discourse of the hysteric, but argued that Freud had not known how to define the discourse of the analyst. So Lacan attempted to establish this discourse by defining its occurrence and its effects and by positing its limits so that analysis could be developed in a community and be taught in the community on both the theoretical and clinical levels. Lacan considered the discourse of the analyst to be one of his original contributions to psychoanalysis.

JOËL DOR

See also: Matheme; Philosophy and psychoanalysis; Seminar, Lacan's.

### Bibliography

- Lacan, Jacques. (1970). Radiophonie. *Scilicet*, 2–3, 55–99.
- . (1991). *Le séminaire, livre XVII: L'envers de la psychanalyse (1969–1970)*. Paris: Seuil.
- . (1998). *On feminine sexuality, the limits of love and knowledge: The seminar, book XX, encore 1972–1973* (Bruce Fink, Trans.). New York: W. W. Norton.

## FOURTH ANALYSIS

“Fourth analysis” (*l'analyse quatrième*), a contribution of the French Fourth Group, or OPLF (French-Language Psychoanalytical Organization), is a new approach to the part of analytic training traditionally known in psychoanalytic societies as “control” or “supervised” analysis. “Thus fourth analysis is in the first place a theory of the control analysis and of the conditions of supervision — a theory never outlined until now — that takes into account the entire group of figures and persons involved in it, as well as their visible and hidden interactions” (*Topique*, 1983). The

term “fourth” refers not only to the Fourth Group itself, but also to the number of protagonists, namely, the analysand, the analyst, the analyst’s analyst, and the analyst who carries out the fourth analysis.

The term *fourth analysis* did not appear in the Fourth Group’s “Principles and Modalities of Functioning” (or “Blue Book” [1969]), even though the idea of a “multi-referential” analysis effectively prefigured it. Such a multi-referential analysis, it was felt, was an adequate characterization of a key moment of analytic training, always assuring that training was not to be reduced to some kind of academic “curriculum.” “Indeed, as soon as the candidate takes on his or her first patient, it is no longer the didactic contract, but also the clinical experience, with all its unknowns, that regulates the relation of the subject to the unconscious. Thus the patient, who is only spoken of indirectly, confronts three analysts with the partiality (in both senses) of their knowledge: the novice, who is striving towards mastery, but also the supervisor and the didactician” (*Topique*, 1969). It is notable that these were still the very terms that the Fourth Group would later question, specifically the term *supervisor*, which is replaced by *fourth analyst*, and *didactician*, which would become “the analyst of the analyst”.

Stress on the multi-referential serves in the first place to highlight and to clarify the harmful effects specific to this plurality when it is not recognized as such. For example, playing the didactician and the supervisor off against each other, or making what one expects from the patient dependent on what one might want to hear or on what one thinks the supervisor wants to hear. Hence the formula that gave birth to the term *fourth analysis*: “There are three chairs and a fourth unconscious, which language does not express fully in known dialects” (*Topique*, 1969).

At the same time, the multi-referentiality specific to fourth analysis is not limited to it, which leads to the necessity of organizing “interanalytic sessions” with other analysts of the Fourth Group and possibly analysts from other societies. “The exemplary character of this four-term situation does not exhaust the diversity of third-party references. The candidate must be able, according to his or her own analytical, theoretical, and clinical progress, to organize in due course debates of variable lengths with other analysts” (*Topique*, 1969).

In the supplement to the “Blue Book” produced by the Fourth Group’s 1970 congress, dedicated

mainly to the notion of the “didactic effect,” the term *fourth analysis* is defined as follows: “The discipline of fourth analysis based on multi-referentiality implies access to the conditions that make the didactic affect possible: not just some regulatory mechanism designed to facilitate experimentation, scholarship, or initiation, but what may be called a *topography*. . . . To become an analyst is to gain access to this tetradimensionality of Freudian training as a process” (*Topique*, 1971).

This points up the important idea that the didactic effect is constructed in a dialectical movement made possible by the shift from a dual relation to a fourfold one. The risk of a major alienation, that is, alienation in knowledge, can thus be counteracted and the didactic effect is defined as never being the direct consequence of the transmission of knowledge.

In 1979, Jean-Paul Valabrega, who had participated in drafting the “Blue Book” in 1969 and 1970, undertook a more thoroughgoing theorization of fourth analysis (Valabrega, 1979), which he defined as a “theory of supervision.” He set out “to better delimit the ‘analytic material’ itself and above all to prevent its potential loss, to insure as much as possible against its unintended erasure” (*Topique*, 1983).

The principle of the fourth analysis has not been modified further. On the other hand, it has been integrated into the greater aim of emphasizing the crucial consideration of the transference and countertransference. The work being carried out on the analysis of the analyst on the basis of fourth analysis allows for, or at least contributes to, a limitation of countertransference effects in the treatment, notably the deafness towards the analysand that comes about when listening to oneself and not the other overwhelms the analyst’s psychic space.

To reopen and to reinstitute, without ever taking as given what must be perceived as a process, is in fact the ideal not only of analytic training, but also of analytic practice, including that of established analysts. The existence, and even the necessity, of interanalytic sessions that bring several analysts face to face around a trainee constitutes a test of each one’s clinical practice; and, at least in principle, it represents an abiding recommendation for every analyst after his or her accreditation. Fourth analysis and interactive sessions, by virtue of their very stringency, are an effective response to what Freud (1937c) said in “Analysis

Terminable and Interminable” about the necessity of the analyst’s putting his or her own analysis to work.

SOPHIE DE MIJOLLA-MELLOR

*See also:* France; Supervised analysis (control case); Training the psychoanalyst.

### **Bibliography**

(1969). La formation du psychanalyste. *Topique*, 1.

(1971). Travaux récents. *Topique*, 6.

(1983). Les historiens et leurs versions. *Topique*, 32.

(1986). Constructions de l’identité. *Topique*, 38.

Valabrega, Jean-Paul. (1994). *La formation du psychanalyste*. Paris: Payot.

---

## **“FRAGMENT OF AN ANALYSIS OF A CASE OF HYSTERIA” (DORA/IDA BAUER)**

Freud’s case history for Ida Bauer, alias Dora (1905), covers approximately seventy hours of treatment. The eighteen-year-old adolescent was forced to go to Freud by her father, Philip Bauer, who was allegedly most concerned by her fainting spells and recent suicide note. Her presenting symptoms included dyspnoea, tussis, nervosa, aphonia, depression, and hysterical unsociability. Combining anamnestic data, reconstruction, and an extensive analysis of two dreams, Freud portrays his patient as a young child observing the primal scene and falling sick from related masturbation. Her subsequent psychic disorder was directly related to her father’s liaison with Frau K. (Peppina Zellenka). Philip denied the liaison and, in his own version of Dora’s analysis, wanted Freud “to talk Dora out” of her belief. Furthermore, Dora had been traumatized twice by Herr K. (Hans Zellenka). Until therapy she had kept the first traumatic occasion to herself, and the second was denied by Hans, who, with his wife and Philip, accused Dora of fabrication. Mrs. Bauer’s “housewife psychosis” and self-absorption further increased Dora’s alienation and desperation.

Freud attempted to demonstrate to Dora that her reproaches toward her adulterous father were self-reproaches, rooted in her unacknowledged love for Hans, who continued to solicit her. Surprisingly, Freud also wanted Dora to stop resisting and to accept Hans, for it “would have been the only possible solution for all

parties concerned.” Dora, however, abruptly terminated treatment—an action Freud considered as another manifestation of her vengeance. Freud pointed out two other shortcomings of his handling of the case: he neglected Dora’s transference, and he overlooked Dora’s homosexual strivings, found at her deepest unconscious level.

Freud’s case history was an organizing clinical experience for him and for the psychoanalytic movement and stands as a paradigmatic record of both psychoanalysis and contemporary culture. It is Freud’s longest text on a female patient and also one of Freud’s memorable trilogy including *The Interpretation of Dreams* (1900a) and *Three Essays on Sexuality* (1905d). It is the first of Freud’s great analytic cases and the first involving an adolescent. Ernest Jones called the case “a model for students of psychoanalysis,” and for Erik Erikson, it was “the classical analysis of the structure and the genesis of a hysteria.” Other critics have described the case as a canonical specimen of conversion hysteria, as Freud’s most graphic demonstration of psychosomatics, and as the case of Freud’s most discussed in psychiatry and psychoanalysis as well as in sociology, anthropology, history, and literary criticism.

Granted, Freud’s various theoretical discoveries in the Dora case, from a practical point of view, must be reevaluated. Freud either downplayed or entirely disregarded Dora’s triple burden of being a woman, a Jew, and an adolescent victimized by two pairs of adults. In his quest to genetically reconstruct the psychic truth, Freud dismissed Dora’s concern about current historical truth and her need to validate her experience. The case lacks indispensable desiderata of psychoanalysis in that there is virtually no interpretation involving transference and in that indoctrination and forced association replace free association.

Even as a case of therapy, Freud’s treatment of Dora was disastrous. By bullying his patient and even wanting her to return to the middle-aged adulterous pedophile who twice traumatized her, Freud subjected her to a third, iatrogenic trauma. There are further indications of Freud’s counter-transferential perturbation: he lied twice and misdated the case twice in his prefatory remarks; he repeatedly errs about Dora’s age and refers to her at different developmental levels (“girl,” “child,” “woman,” “female person,” “lady”); he confusedly traces Dora’s coughing and aphonia to ages eight and twelve; he attributes to Dora an adult-like love of Hans during her “first years” in Merano, Italy (she was there from age six to age seventeen); and he grossly

misinterprets Dora's silence as agreement when he mistakenly tells her that at age seventeen (she was really fifteen), she was committed to her traumatizing seducer, much like her mother at the age of seventeen.

According to his own words, he wrote up the case "during the two weeks immediately following" termination; his correspondence with Wilhelm Fliess contains explicit statements that he was writing the case history between January 10 and 24, a two-week period in 1901. The implications of the duration of Freud's composition have gone completely unnoticed. When Dora decided to quit therapy two weeks before she actually did, Freud irritably charged that she was reacting like a maid who gives a two-week notice before leaving her employer. But Freud himself unconsciously behaved immaturely during his composition of the case, which partially took on the character of an acting out, or better yet, a writing out. His two weeks of writing up the case was a way of dismissing it and of trying to rid himself of Dora.

As a follow-up to Dora's treatment, Freud proceeded to write up her case history. Pertinently, Freud never considered Dora's bisexuality and transference together; his defensive typographic separation of these two dynamics enabled him to ward off any notion of maternal transference. However, far from dissolving his countertransference toward Dora, Freud re-enacted it with the reader, whom he tried to seduce into agreement.

PATRICK MAHONY

*See also:* Acting out/acting in; Adolescence; Bauer, Ida; Cruelty; Flight into illness; Free association; Hysteria; Identification; Latent dream thoughts; Oedipus complex; Psychoanalytic treatment; Resolution of the translation. Secret; Somatic compliance.

### Source Citation

Freud, Sigmund. (1905e). Bruchstück einer Hysterie-Analyse. *M Schr. Psychiat. Neurol.*, XVIII, p. 285310, 408–467; *G.W.*, V, p. 161–286; Fragment of an analysis of a case of hysteria. *SE*, 7: 1–122.

### Bibliography

Erikson, Erik H. (1964). *Insight and responsibility*. New York: W. W. Norton.

Freud, Sigmund. (1900a). The interpretation of dreams. *SE*, 4: 1–338; 5: 339–625.

Jennings, Jerry. (1986). The revival of "Dora": Advances in psychoanalytic theory and technique. *Journal of the American Psychoanalytic Association*, 34, 607–634.

Laurent, Éric (1986). Lectures de Dora. In *Fondation du champ freudien, Rencontre internationale, Hystérie et obsession* (pp. 29–42). Paris: Navarin.

Mahony, Patrick. (1996). *Freud's Dora: A historical, textual, and psychoanalytic study*. New Haven: Yale University Press.

## FRAGMENTATION

*Fragmentation* describes a state of the self that is the opposite of cohesion. It is a diagnostic sign.

This notion appeared in Heinz Kohut's 1968 article "The Psychoanalytic Treatment of Narcissistic Personality Disorders." A sign of the narcissistic personality, as compared with the neuroses, fragmentation triggers disintegration anxiety, a counterpart of castration anxiety. The fragmentation corresponding to the autoerotic stage is total in psychosis, in contrast to the narcissistic personality, in which the self is cohesive. In narcissism, transient fragmentation is seen during analysis and during certain periods when the self is vulnerable, such as adolescence.

This notion was developed throughout Kohut's work, becoming one of the four fundamental concepts of self psychology set forth in "Remarks about the Formation of the Self" (1974). To Kohut, narcissistic pathology tends to be progressively reduced to variations in the state of the self, which is fragmented at the preoedipal and oedipal levels. Fragmentation of the self triggers an intensification of the drives, which are redefined as products of the disintegration of the self in the service of its restoration.

Fluctuations in the state of the self are important clinical data for diagnosis and treatment, but the drives become secondary to the self.

AGNÈS OPPENHEIMER

*See also:* Disintegration, products of; Schizophrenia; Self, the.

### Bibliography

Kohut, Heinz (1968). The psychoanalytic treatment of narcissistic personality disorders. In *The search for the self* (Vol. 1). New York: International Universities Press.

———. (1971). *The analysis of the self*. New York: International Universities Press.



———. (1974). Remarks about the formation of the self. In *The search for the self* (Vol. 2). New York: International Universities Press.

———. (1977). *The restoration of the self*. New York: International Universities Press.

———. (1984). *How does analysis cure?* Chicago: University of Chicago Press.

## FRAMEWORK OF THE PSYCHOANALYTIC TREATMENT

The “frame of psychoanalytic treatment” refers to the formal and contractual means necessary for establishing the situation that characterizes psychoanalysis compared to other forms of psychotherapy. Although the frame has been at the heart of psychoanalytic practice ever since its origins, considerations of its structure and function are more recent, dating from the Second World War. One of the first to investigate this frame was José Bleger in an article entitled “Psychoanalysis of the Psychoanalytic Frame” (Bleger, 1967).

This frame was gradually developed by Freud for what were often circumstantial or personal reasons, but he eventually developed a set of uniform recommendations consistent with the theoretical and practical modalities of treatment. As early as 1904 he described his “psychotherapeutic method”: “Without exerting any other kind of influence, he invites them to lie down in a comfortable attitude on a sofa, while he himself sits on a chair behind them outside their field of vision. He does not even ask them to close their eyes, and avoids touching them in any way, as well as any other procedure which might be reminiscent of hypnosis. The session thus proceeds like a conversation between two people equally awake, but one of whom is spared every muscular exertion and every distracting sensory impression which might divert his attention from his own mental activity” (1904a, p. 250). Nine years later he provided additional details such as frequency and duration of the sessions and method of payment—parameters that were as important for proper treatment as the mutual obligations of free association or the prohibition to act out on the part of the analysand and free-floating attention or the rule of abstinence on the part of the analyst (1913c).

The restrictions imposed by the treatment setting apply to both parties, even if its contractual nature is

often overlooked in order to emphasize the pseudo-power attributed to the psychoanalyst by virtue of the patient’s masochism. The frame appears to function as the representative of the incest prohibition in the analytic situation, a prohibition that in fact favors expression and analysis. The frame can be considered an “excluded middle” that hovers over the protagonists during the session, reminding them that every “dualistic” relationship is illusory, even during moments of the most intense regression.

Opinions vary regarding these interpretations since the elements that characterize the frame are rich with symbolization. José Bleger (1967) distinguishes the frame within the psychoanalytic situation as a “non-process” consisting of “constants within whose bounds the process takes place” (p. 511), and he locates its origin in the “most primitive fusion with the mother’s body” (p. 518). He subdivides the frame into two elements: the frame proposed by the analyst and accepted by the patient, and the frame formed by projections of the patient’s most primitive symbiotic associations. It is with this last point that the concepts of “container-contained,” the analyst’s alpha function (Wilfred Bion), and Donald Winnicott’s “setting” are associated. For Winnicott, the analyst “expresses” his love for the patient by his reflected interest and his hatred by his observance of the rites of payment and scheduling (Winnicott, 1958). According to Jean-Luc Donnet, “the frame is both protection and threat, just as its symbolization is forced and liberating” (1973). Jean Laplanche, with his image of the psychoanalyst’s “tub,” describes a “double-wall setting” wherein the outside wall, “purely legalistic and formal” but contractual, is necessary to preserve the inner wall, which is subject to the uncertainties of the analytic process and is needed for sexual issues and the transference neurosis to manifest themselves (Laplanche, 1987).

The arrangement of the frame for psychotic patients or as a function of what Lacan and his students refer to as the temporal scansion of the session introduces the question of its relationship with the establishment and ongoing coherence of a psychoanalytic process. There are a number of parameters involved and each of them raises the question of its role and importance in managing the situation: the number and duration of sessions (four sessions of fifty minutes at a minimum according to official American guidelines, three of forty-five minutes for French members of the International Psychoanalytic

Association, shorter for others, longer for Freud), distribution throughout the week (frequent sessions, sometimes several a day for patients who live far away), payment (cash or check), accepting third-party payment or not, problems associated with days off, with vacations, with changes to the ritual (moving, for example), the intrusion of the telephone, contact during, or outside, the session (Sándor Ferenczi's "active technique" or "mutual analysis," Michael Balint's or Donald Winnicott's physical holding), and so on.

Rigid attitudes on one side, transgressive relativism on the other, reference to the paternal prohibition against incest versus a conception of the frame as a womb implying a total return to a primal state, a setting for hypnosis or a condition for working-through—the conditions associated with the unique nature of psychoanalytic treatment possess a non-alienating value only because they are based on a contract that circumscribes them and that can at any moment be torn up by either of its cosignatories.

ALAIN DE MIJOLLA

*See also:* Abstinence/rule of abstinence; Initial interview(s); Face-to-face situation; Free association; "Lines of Advance in Psycho-Analytic Therapy"; Money and psychoanalytic treatment; Neutrality, benevolent neutrality; Psychoanalytic treatment.

### **Bibliography**

- Bleger, José. (1967). Psychoanalysis of the psycho-analytic frame. *International Journal of Psycho-Analysis*, 48 (4), 511–519.
- Donnet, Jean-Luc. (1973). Le divan bien tempéré. *Nouvelle revue de psychanalyse*, 8, 23–49.
- Freud, Sigmund. (1904a). Freud's psycho-analytic procedure. *SE*, 7: 247–254.
- . (1913c). On beginning the treatment (Further recommendations on technique of psycho-analysis I). *SE*, 12: 121–144.
- Laplanche, Jean. (1989). *New foundations for psychoanalysis* (David Macey, Trans.). Cambridge, MA: Basil Blackwell. (Original work published in 1987)
- Winnicott, Donald W. (1958). *Collected papers: Through paediatrics to psycho-analysis*. London: Tavistock Publications.

### **Further Reading**

- Busch, Fred. (1995). Beginning analytic treatment: Establishing an analytic frame. *Journal of the American Psychoanalytic Association*, 43, 449–468.

## **FRANCE**

Freud spent several months, from October 1885 to February 1886, studying in Paris with Jean Martin Charcot at the Salpêtrière Hospital. This experience greatly determined his orientation toward psychopathology. In his article "Heredity and the Aetiology of the Neuroses," published in French in 1896 in the *Revue neurologique*, the word *psychoanalysis* appeared for the first time.

In France, Jean Martin Charcot's legacy gave rise to bitter disputes on the nature of the mind, and Pierre Janet's theories were widely accepted in medical and philosophical circles. These two factors explain the poor reception given to Freud's ideas for many years. The article that Freud called "the first article on psychoanalysis written in France," by Doctor René Morichau-Beauchant, professor of medicine in Poitiers, appeared as late as November 14, 1911, in *La gazette des hôpitaux civils et militaires*. In 1913 a French translation of Freud's essay "The claims of psychoanalysis to scientific interest" in the Italian journal *Scientia* went unnoticed.

In 1914 Professor Emmanuel Régis and his assistant Angelo Hesnard, a naval doctor in Bordeaux, wrote the first book on psychoanalysis, *La psychanalyse des névroses et des psychoses*, but the First World War cut short further interest in the field. It was not until December 1920 that the *Revue de Genève* and Éditions Payot published a French translation of Freud's essay "On the History of the Psycho-Analytic Movement" (1914).

With Freud's support, Eugénie Sokolnicka, a Polish psychiatrist who had settled in France, began analyzing young psychiatrists working at the Clinique des maladies mentales at the Sainte-Anne Hospital under the direction of Professor Henri Claude. Psychoanalysis became fashionable in France around 1921: In October 1921 André Breton traveled to Vienna to meet Freud, the "greatest psychologist of our time." Henri-René Lenormand's play "Le mangeur de rêves" (1921) turned out to be a success. And the Belgian journal *Le disque vert* published a special issue in 1924 titled "Freud et la psychanalyse" (Freud and psychoanalysis).

Though the medical profession remained overtly hostile to psychoanalysis, a number of young psychiatrists interested in psychoanalysis, including René Allendy, Angélo Hesnard, René Laforgue, and Eugène

Minkowski, decided to launch a journal that was clearly psychoanalytic in orientation. The first volume of *Évolution psychiatrique* appeared in 1925, followed by a second in 1927. In 1930 the journal founders formed a learned society of the same name, which was still in existence in 2005. In July 1926 these psychiatrists, along with Raymond and Ariane de Saussure, Édouard Pichon, and Adrien Borel, organized the *Conférence des psychanalystes de langue française* (Conference of French-Speaking Psychoanalysts) in Lausanne, the origin of the *Congrès des psychanalystes de langues romanes* (Congress of Romance Language Psychoanalysts) and the *Congrès des psychanalystes de langue française* (Congress of French-Speaking Psychoanalysts), which take place annually.

On November 4, 1926, the *Société psychanalytique de Paris* (SPP; Paris Psychoanalytic Society) was formed under the guidance and with the assistance of Princess Marie Bonaparte, Napoleon's great-grand-niece, who was being analyzed by Freud and who later became close friends with him. Her circle included Eugénie Sokolnicka, Angélo Hesnard, René Allendy, Adrien Borel, René Laforgue, Georges Parcheminey, Édouard Pichon, and Rudolf Loewenstein. (The last was a Polish Jewish émigré who, after training at the Berlin Institute, settled in France, where he became the first and best known teaching analyst. He was naturalized in 1930.) Also in her circle were a number of French-speaking Swiss analysts. They included Charles Odier, Henri Flournoy, and Raymond de Saussure (the son of the linguist), all of whom made important contributions to the growth of the new society. The first issue of the *Revue française de psychanalyse* appeared on June 25, 1927, and on January 10, 1934, the *Institut de psychanalyse* was created and remained active until 1940.

The development of psychoanalysis encountered some difficulties, however, notably with the International Psychoanalytical Association (IPA) and because of Freud himself. The French welcomed Freud's "psychoanalytic method" but in general rejected Freudian "doctrine," to paraphrase the title of a critical essay by Roland Dalbiez published in 1936. Because of this tendency, Marie Bonaparte played a crucial role. She was not a physician, and by being jealously faithful to Freud, she prevented psychoanalysis in France from falling completely under the sway of institutional psychiatry (Mijolla, 1988b). She also began translating Freud's writings intermittently until 1988, when a

team led by Jean Laplanche began a new translation of Freud's complete works (Mijolla, 1991).

During the 1936 international IPA congress in Marienbad, Czech Republic, the young Jacques Lacan presented a paper titled "Le stade du miroir" (The mirror stage, or phase). He became a member of the *Société psychanalytique de Paris* in December 1938, nine years after Sacha Nacht (October 1929) and eighteen months after Daniel Lagache (July 1937), his future rivals, both of whom, like Lacan, were analyzed by Rudolf Loewenstein. Though there were few truly innovative French presentations aside from Lacan's paper, many presentations helped spread Freudian theory and technique, which was for the most part based on the work of Sándor Ferenczi. The recommendations made by René Laforgue (on scotoma, schizophrenia, and family neurosis) went unanswered, as did the many articles and essays by Angélo Hesnard, Édouard Pichon, and René Allendy.

Freud received assistance in emigrating from Austria from U.S. Ambassador William C. Bullitt and Marie Bonaparte, who paid the "departure tax" demanded by the Nazis and saved his antiquities collection. Following his departure from Vienna, Freud stayed in Paris on June 5, 1938, while waiting to embark for London. Because of Nazi persecutions, Jewish psychoanalysts had begun to leave Germany in 1933, usually passing through Switzerland or France. They included René Spitz and Heinz Hartmann. They too received help from Marie Bonaparte, as well as from Anne Berman (Bonaparte's secretary), René Laforgue, and Paul Schiff.

On June 13, 1940, the day before Hitler's troops entered Paris, Sophie Morgenstern, one of the first child analysts, committed suicide. The *Société psychanalytique de Paris* and the *Institut de psychanalyse* closed their doors, and the *Revue française de psychanalyse* ceased publication. There was no overtly psychoanalytic activity in France during the four years of German occupation. Rudolf Loewenstein succeeded in leaving for America, where he settled for good. Marie Bonaparte went into exile in Cape Town, South Africa. Sacha Nacht, who worked with the Free French forces, barely escaped deportation. Daniel Lagache continued teaching in Clermont-Ferrand, where the University of Strasbourg had temporarily reestablished itself. Paul Schiff joined the troops that would later liberate Italy and France, while Jacques Lacan, Françoise Dolto, Marc Schlumberger, and John Leuba

continued their activities in Paris. Only René Laforgue attempted, from 1940 to 1942, to create a French section at the Göring Institute, but his efforts were in vain. His subservient attitude toward the occupation authorities resulted in his exclusion from the Société psychanalytique de Paris following liberation (Mijolla, 1988a).

After 1945 psychoanalytic activity resumed in France. A number of new figures appeared on the scene: Maurice Bouvet, Serge Lebovici, René Held, Maurice Bénassy, Francis Pasche. On July 25, 1946, the annual Congrès des psychanalystes de langue française (Congress of French-Speaking Psychoanalysts) resumed in Montreux, Switzerland. In November, Maryse Choissy founded the Centre d'étude des sciences de l'homme (Social Sciences Study Center) and launched the journal *Psyché*, both of which were influenced by the Catholicism of Pierre Teilhard de Chardin. That same year the Centre psychopédagogique Claude-Bernard (Claude Bernard Psychopedagogical Center) was created, with Georges Mauco as nonmedical director. Juliette Boutonier was the medical director, but she turned the position over to André Berge in order to replace Daniel Lagache at the University of Strasbourg. Lagache had been appointed to a position at the Sorbonne, where he created a degree program in psychology. In 1948 a new publisher, Presses universitaires de France, began publishing the *Revue française de psychanalyse*.

The Cold War began, and the Communist journal *La nouvelle critique* published an article in 1949 referring to psychoanalysis as a "reactionary ideology." The article, written by four psychoanalysts, one of whom was Serge Lebovici, reinforced the criticisms made by Georges Politzer before the war. Years later, between 1973 and 1977, Lebovici was the first French psychoanalyst to be made president of the International Psychoanalytical Association.

The success of psychoanalysis continued to attract candidates and presented the problem of training them. Moreover, a suit brought against Margaret Clark-Williams between 1950 and 1952, a psychoanalyst but not a medical doctor, for illegally practicing medicine, though concluded in her favor, exposed the collective responsibility of the psychoanalytic community and the need to establish criteria for practice.

After three years of violent debate, flip-flopping alliances, and maneuvering between the three French

leaders who acquired their positions after the war, the decision to create a new Institut de psychanalyse caused a split in the Société psychanalytique de Paris. None of the three were especially interested in making the institutions democratic, and they waged a kind of open warfare with one another that would leave scars on the psychoanalytic community in France for years to come. Aside from their personal ambitions, they had opposing ideas about the theory, practice, and institutional organization of psychoanalysis. Sacha Nacht wanted to remain faithful to the norms of the International Psychoanalytical Association and aligned with medical education. Daniel Lagache favored academic training. The third, Jacques Lacan, developed original theories and methods of therapy, and the latter, especially his "variable-length sessions," did not comply with international standards.

On June 16, 1953, a motion of no confidence was passed against Jacques Lacan, then president of the Société psychanalytique de Paris. Daniel Lagache, Juliette Favez-Boutonier, and Françoise Dolto then announced that they would be leaving the society to form the Société française de psychanalyse (SFP; French Society for Psychoanalysis). Lacan joined them and was followed by nearly half the students, who were behind the split. But the defectors, in their desire to create an institute free of Sacha Nacht's authority, had overlooked the fact that they would be excluded from the International Psychoanalytical Association and would have to undergo a lengthy period of scrutiny by the international community before they could prove their ability to train new analysts (Mijolla, 1996).

In September 1953, the sixteenth Conférence des psychanalystes de langues romanes took place and, at the end of the SPP meeting, Lacan presented to the members of his new society, the Société française de psychanalyse, his "Discours de Rome" on the function of language in psychoanalysis.

The Institut de psychanalyse de Paris (Paris Institute for Psychoanalysis) was officially established on June 1, 1954. Sacha Nacht remained the director until 1962, when Serge Lebovici replaced him. Through the Centre de diagnostic et de traitements psychanalytiques (Center for Diagnostics and Psychoanalytic Treatment), run by Michel Cénac and René Diatkine, Nacht was to become, for nearly thirty years, the symbol of traditional psychoanalysis in France, to the detriment of the Société scientifique, which did not

return to its former prestige until 1986. To strengthen its image, the Twentieth International Congress of the International Psychoanalytical Association was held in Paris in 1957. The IPA had met there once before, in 1938, and would meet in Paris again in 1973.

Around this time new directions in psychoanalysis were explored. For example, in Paris in 1958 Philippe Paumelle, Serge Lebovici, and René Diatkine created the Association de santé mentale (Mental Health Association), which provided doctors and social workers with training in psychoanalysis. Also established that year were the Groupe Lyonnais, the first regional branch of the Société psychanalytique de Paris, and the Séminaire de perfectionnement, an annual meeting for psychoanalysts working throughout France, similar to the Journées provinciales run by the Société française de psychanalyse.

The rivalry that developed between the two societies promoted the growth of theoretical developments as well as new institutional forms. The work of Maurice Bouvet is a case in point. Through his writing, Bouvet attempted to counteract the growing interest in the ideas of Jacques Lacan. Unfortunately, he died at the early age of forty-nine in 1960. In 1962 an annual prize in psychoanalysis was created in his name.

There were a number of psychoanalysts for children working in France at this time. In the Société psychanalytique de Paris there were Serge Lebovici, René Diatkine, Roger Misès, Michel Soulé, Pierre Mâle, Jean Favreau, Ilse Barande, and Pierre Bourdier. In the Société française de psychanalyse there were Jenny Aubry, Françoise Dolto, Maud Mannoni, and Victor Smirnoff. In the field of psychosomatics were Jean-Paul Valabrega (SFP) and the team formed around Pierre Marty: Michel Fain, Michel de M'Uzan, and Christian David (all SFP members). David went on to found the Institut de psychosomatique (Institute of Psychosomatics). Those working in psychodrama and group psychoanalysis included Jean and Evelyne Kestenberg, Jean Gillibert, and Robert Barande (SPP), and Didier Anzieu, Angélo Bejarano, René Kaës, André Missenard, and Jean-Bertrand Pontalis (SFP). Primary representatives in the field of psychogenesis and the treatment of psychosis were Sacha Nacht and Paul-Claude Racamier of the SPP, and Jean-Louis Lang, Serge Leclair, François Perrier, and Guy Rosolato of the SFP. Worthy of note is that there was a certain coolness in France toward Melanie Klein's theories, which remained relatively unknown until the

1970s, following the work of James Gammil, Jean Begoin, and Florence Begoin-Guignard.

Jacques Lacan became increasingly important in French psychoanalysis and as a leader of young analysts. He published articles in *La psychanalyse*, the SFP review created in 1955 (the eighth and last number appeared in 1964), and in 1953 began giving his famous seminars. The increasingly well-attended sessions were held every Wednesday from 12 noon to 3 p.m., initially at the Sainte-Anne Hospital, then at the École normale supérieure, and finally at the Paris law school. On November 7, 1955, in Vienna, he introduced his call for a "return to Freud," which met with tremendous success. Interest in the work of Claude Lévi-Strauss and structuralism during the 1960s contributed to the dissemination of a conception of psychoanalysis unrelated to psychology and without any therapeutic aims (in 1957 Lacan had spoken of "excessive healing"). The impact of Lacan's ideas can be judged from the October 1960 Sixth Colloque de Bonneval, organized by Henri Ey on the unconscious. In the presence of Jean Hyppolite, Maurice Merleau-Ponty, Eugène Minkowski, Henri Lefebvre, and Paul Ricoeur, members of the two societies confronted one another. In that setting the work of a number of hitherto unknown psychoanalysts came to light: André Green and Conrad Stein of the Société psychanalytique de Paris, and Jean Laplanche, Serge Leclair, and François Perrier of the Société française de psychanalyse.

Lacan's success guaranteed him a role within the Société française de psychanalyse that did not always sit well with his colleagues, especially since his theoretical development, together with the unusual nature of his personal practice, made him persona non grata within the traditional international psychoanalytic community. There were increasing conflicts within the SFP over Lacan, and these grew worse as the conditions for the society's readmission to the Institut de psychosomatique were communicated to him in 1961 during the twenty-second international congress in Edinburgh, just as it received the status of a study group. The SFP was asked to adhere to the guidelines for didactic analysis and training (four sessions of forty-five minutes per week and a year of therapy after the beginning of supervised therapy). Everyone knew that Lacan would never accept these requirements.

In spite of diplomatic efforts by the three-member group within the SFP known as the "troika"—Wladimir

Granoff, Serge Leclaire, and François Perrier—the situation grew worse until several members of the SFP, including some of Lacan’s former analysts, urged that he, along with Françoise Dolto, be removed from the list of teaching analysts, a decision that was ratified in November 1963. This led to a split within the SFP. One group of members formed the Association psychanalytique de France (French Psychoanalytic Association), which chose Daniel Lagache as its first president and was accredited by the Institut de psychosomatique on July 28, 1965, during the twenty-fourth international congress in Amsterdam.

On June 21, 1964, Lacan founded the École Freudienne de Paris (EFP; Freudian School of Paris), which, over a period of sixteen years, became one of the leading forces in the French psychoanalytic movement. Organized into groups known as “cartels,” it published an annual list of members. This did not mean that the organization recognized them as psychoanalysts, for according to Lacan, “The psychoanalyst’s authority can only come from himself.” Since the school was intent on making a difference within the psychoanalytic community, some members were designated “EFP analysts,” and on October 9, 1967, Lacan instituted a test to enable members to obtain the title. As a result of this action, Piera Aulagnier, François Perrier, and Jean-Paul Valabrega quit the École Freudienne de Paris in January 1969 to create the Quatrième groupe, Organisation psychanalytique de langue française (The Fourth Group, or Francophone Psychoanalytic Organization). (Piera Aulagnier, in 1967, founded, together with Jean Clavreul and Conrad Stein, the journal *L’inconscient*, of which only eight issues were published.) This group introduced new criteria of membership admission and methods of training: “the fourth analysis.”

Lacan’s claim that “the unconscious is structured like a language” helped rally to the cause of psychoanalysis Marxists like Louis Althusser and several priests, including the Jesuit Louis Beirnaert. Subsequently, the French Communist Party and the Catholic clergy, both of which had been hostile to Lacan, softened their position. More significantly, Lacan won over to his cause the French intelligentsia, along with a number of foreign students, thereby mobilizing the forces for a media campaign unique in the field of psychoanalysis.

The ground for Lacan’s success had already been prepared, as Serge Moscovici showed in his dissertation, “La psychanalyse: Son image et son public”

(Psychoanalysis: its image and public), completed in 1961. In 1958 Jean-Paul Sartre worked on the screenplay for the first film about Freud. *Freud: The Secret Passion*, directed by John Huston, appeared in movie theaters in 1962. Between December 1962 and July 1963, Marthe Robert presented a series of radio broadcasts titled *The Psychoanalytic Revolution: The Life and Work of Sigmund Freud*.

The literature on psychoanalysis began to grow. The Presses universitaires de France published Freud’s letters to Wilhelm Fliess and Ernest Jones’s biography of Freud in its series Bibliothèque de psychanalyse (Library of Psychoanalysis), edited by Daniel Lagache and later Jean Laplanche. In 1961 Gérard Mendel founded the series Science de l’homme (Science of Man) at Éditions Payot. This was followed, in 1964, by the series Le champ Freudien (The Freudian Field), edited by Jacques Lacan, then by Jacques-Alain Miller, at Éditions du Seuil, and in 1973 by L’espace analytique (The Analytic Space), edited by Maud Mannoni and Patrick Guyomard at Denoël. This last press published memoirs about Vienna and the early years of psychoanalysis in its series *Freud et son temps* (Freud and His Time), edited by Jacqueline Rousseau-Dujardin. Gallimard launched the series *Connaissance de l’inconscient* (Knowledge of the Unconscious), edited by Jean-Bertrand Pontalis, as well as the journal *Nouvelle revue de psychanalyse*, which appeared in the spring of 1970 (it ceased publication in the fall of 1994 with number 50). Laplanche and Pontalis were also the authors of the celebrated *Language of psychoanalysis*, first published in 1967. A number of academic journals were launched at this time: *Cahiers pour l’analyse* in 1966, *Scilicet* in 1968, *Topique* and *Études freudiennes* in 1969, *Ornicar?* in 1975, *Confrontation* in 1979, and *L’écrit du temps* in 1982. In 1965 Paul Ricoeur published *De l’interprétation: Essai sur Freud*, an example of what was most attractive about psychoanalysis to philosophers and academics.

Jacques Lacan’s *Écrits* appeared at the end of 1966 as part of the series Le champ freudien, published by Éditions du Seuil. The book achieved considerable success with the public in spite of the difficulty of the author’s style and ideas. As the popularity and longevity of Lacan’s seminars show, the École Freudienne de Paris and Lacanian thought in general began to occupy an increasingly prominent place in French psychoanalytic circles. Lacan’s ideas soon spread around the world, especially in South America.

The student movements of May 1968 were attracted to a Marxist version of Freud inspired by Herbert Marcuse and Wilhelm Reich. In October of that year the school reforms led to the creation of a department of psychoanalysis at the University of Paris VIII in Vincennes by Serge Leclair and Jacques-Alain Miller, Lacan's son-in-law, and a department of clinical social science at the University of Paris VII. In October 1968 Gérard Mendel, the founder of socio-psychoanalysis, published *La révolte contre le père* (A revolt against the father), an explanation of the student protests. At the opposite end of the spectrum, in 1969 there appeared *L'univers contestationnaire* (The universe of conflict) by Béla Grunberger and Janine Chasseguet-Smirgel, writing under the pseudonym André Stéphane.

Opposition to psychoanalysis arose with the publication in 1969 in *Les temps modernes* of "L'homme au magnétophone" (The man with a tape recorder), with a commentary by Jean-Paul Sartre. Its publication led Jean-Bertrand Pontalis to resign from the journal's editorial board. In 1972, Gilles Deleuze and Félix Guattari published *Anti-Oedipus: Capitalism and Schizophrenia*, and Pierre Debray-Ritzen published *La scholastique freudienne*, a caricature of past, present, and future criticisms of psychoanalysis in France.

In the 1970s the French psychoanalytic movement split into mutually exclusive factions. In 1974 René Major and Dominique Geahchan created the group Confrontation, which claimed to be independent of the various psychoanalytic societies but over time grew closer to the Lacanians. They organized animated discussions led by Serge Leclair (1977) and representatives of the French feminist movement, led by Antoinette Fouque (1979). Although theoretical and clinical advances continued to be made in the Société française de psychanalyse and the Association psychanalytique de France, as well as the Quatrième groupe, public and media attention focused on Jacques Lacan and his students.

With age, Lacan's health and productivity declined. Jacques-Alain Miller undertook the publication of an "official" transcript of Lacan's seminars (often contested by Miller's adversaries) and assumed a guiding role in managing the École Freudienne de Paris, which displeased Lacan's older students. In the face of all this dissension, Lacan, by now quite ill, ordered his school dissolved on January 5, 1980. This led to a court trial and the division of his followers into mutually hostile groups. In his letter to the thousand, Lacan announced, on February 21, 1980, the foundation of

the Cause Freudienne. Shortly thereafter Jacques-Alain Miller founded the École de la cause Freudienne. In the years that followed the school developed an international reputation and became especially well established in South America. Jacques Lacan died on September 9, 1981.

In November 1980 Dominique Geahchan helped create the Collège de psychanalystes (Council of Psychoanalysts), which, despite its name, was not a training organization. It ceased functioning in June 1994. Following the dissolution of the École Freudienne de Paris, several new groups came into existence: in 1982 the Cercle Freudien (Freudian Circle) and the Association Freudienne internationale (International Freudian Association); in 1983 the Cartels constituants de l'analyse Freudienne (Constituent Cartels for Freudian Analysis), the Convention psychanalytique (Psychoanalytic Convention), and the Mouvement du coût Freudien (Freudian Cost Movement) the École Lacanienne de psychanalyse (Lacanian School of Psychoanalysis); and in 1986 the Séminaires psychanalytiques de Paris (Paris Psychoanalytic Seminars). Also in 1982 the Centre de formation et de recherches psychanalytiques (Center for Psychoanalytic Training and Research) formed around Octave and Maud Mannoni. Its dissolution in 1994 led to the creation, in 1995, of the Espace analytique (Analytic Space), of which Maud Mannoni was president until her death in 1998, and the Société de psychanalyse Freudienne (Freudian Society for Psychoanalysis), under the direction of Patrick Guyomard. Many of these associations were subject to internal dissension and disappeared (at least in their initial form) during the 1990s.

In France and elsewhere in the world, a crisis followed as a result of the excessive enthusiasm—in particular, excessive psychiatry and excessive ideology—generated by an idealized image of psychoanalysis. This enthusiasm was clearly associated with the personality and fame of Jacques Lacan. Subsequently, psychiatrists began to focus on the neurosciences. On another front, renewed enthusiasm for philosophy and religion led to a decline in interest in Freudian theory in the universities. Within the field of psychoanalysis, interactions over the years among the various psychoanalytic groups, which the first meetings of Confrontation had in its time attempted to establish, began to overcome the violent splits of the past.

The Société psychanalytique de Paris continued to assert its authority as the chief French psychoanalytic

institution, partly through the increased readership of the *Revue française de psychanalyse* at a time when a number of publications ceased publication, many because of poor sales. In fact, the association came to be viewed as akin to a public institution by 1997. Around this time André Green became internationally well known for his writings on the “dead mother,” “the narcissism of death,” and “the negative,” and Joyce McDougall became well known, especially in North America, for her work on the concept of normalcy and addiction. Although less well known, Conrad Stein, following the publication of his *L'enfant imaginaire* (The imaginary child; 1971) and the organization of a number of conferences through *Études Freudiennes* (Freudian Studies), continued his research on Freud and his criticism of the institutionalization of psychoanalysis.

Some APF members too made important contributions to the field. Worthy of mention are Guy Rosolato's work on the symbolic order and sacrifice, generalized seduction, and deferred action (a topic proposed by Jean Laplanche after a detailed reading of Freud); the theoretical work and fiction of Jean-Bertrand Pontalis; Daniel Widlöcher's work on change; and Didier Anzieu's research on Freud's self-analysis, the “skin ego,” psychodrama, and group analysis, a field also investigated by René Kaës.

Through the publication of *La violence de l'interprétation: Du pictogramme à l'énoncé* (The Violence of Interpretation: From Pictogram to Statement; 1975), Piera Aulagnier's work provided original theoretical material for understanding and treating psychosis (Mijolla-Mellor, 1998). Although somewhat less synthetic, the work of Octave and Maud Mannoni broadened the scope of psychoanalytic research, especially in the area of child psychoanalysis, a field greatly influenced by the work of Serge Lebovici, René Diatkine, and Michel Soulé. Françoise Dolto had a considerable impact on psychoanalysis in France through her original and provocative ideas, some of which generated considerable controversy. Her radio presentations and the creation of the *Maisons vertes*, psychoanalytic facilities for children, brought her considerable public recognition in France, and her books have remained successful.

A number of other authors—Béla Grunberger, Michel Fain, Jean Bergeret, Jean Guillaumin, Jean-Paul Valabrega, Serge Leclair, François Perrier—made important contributions to specifically French psychoanalysis, which has been characterized by a tendency

toward clinically based theorizations and is generally less empirical than the work of Anglo-American authors. In particular, Lacanian psychoanalysts have emphasized the importance of language and are probably closer to postwar French philosophy than any other branch of psychoanalysis. They have been influenced by thinkers as diverse as Jean-Paul Sartre, Maurice Merleau-Ponty, Claude Lévi-Strauss, Michel Foucault, and Jacques Derrida (who included psychoanalysis in the curriculum when he created the *Collège de philosophie* in 1983).

Psychoanalysts in France remain unlicensed in spite of several attempts by the government to institute licensing. Although psychoanalysts have managed to obtain a number of rights as private practitioners through psychoanalytic associations, it is as accredited psychologists that they are authorized to practice psychotherapy and analysis. The attempt in December 1989 by Serge Lebovici, then head of the *Association pour une instance*, to create a professional body consolidating all psychoanalysts in France was rebuffed by associations that were members of the International Psychoanalytical Association. These organizations had no desire to merge with the numerous practitioners operating in the Lacanian tradition, because they felt that training requirements in this tradition were inadequate.

There has been considerable interest in the history of psychoanalysis as well. In June 1985 the *Association internationale d'histoire de la psychanalyse* (International Association for the History of Psychoanalysis) was created. In 1984 this association merged with the *Société internationale d'histoire de la psychiatrie* (International Society for the History of Psychiatry), created in 1982, to become the *Société internationale d'histoire de la psychiatrie et de la psychanalyse*. In 1991, encouraged by Joseph Sandler, the International Psychoanalytical Association formed an Archives and History Committee within its organization.

French developments in psychoanalysis have also expanded and exerted influence outside the country. One sign of this is the election, in 1999, of Daniel Widlöcher as president of the International Psychoanalytical Association and of Alain Gibeault as secretary general, both of whom are French. Although no other French theoretician has achieved Jacques Lacan's global recognition or, like Lacan, has created schools and institutions, the body of theoretical and clinical research in French is considerable. In spite of the often irreconcilable differences within the French psychoanalytic



community, this work has continued to enrich the development of psychoanalysis throughout the world.

ALAIN DE MIJOLLA

### Bibliography

- Mijolla, Alain de. (1982). La psychanalyse en France, 1893–1965. In Roland Jaccard (Ed.), *Histoire de la psychanalyse* (Vol. 2, pp. 9–105). Paris: Hachette.
- . (1984). Quelques avatars de la psychanalyse en France. *Évolution psychiatrique*, 49 (3), 773–795.
- . (1985). Pulsion d'investigation, fantasmes d'identification et roman familial. *Topique*, 34, 33–59.
- . (1988a). Psychoanalysis and psychoanalysts in France between 1939 and 1945. *International Forum of Psychoanalysis*, 12, 136–156, 2003.
- . (1988b). Quelques aperçus sur le rôle de la princesse Marie Bonaparte dans la création de la Société psychanalytique de Paris. *Revue française de psychanalyse*, 52 (5): 1197–1214.
- . (1991). L'édition en français des œuvres de Freud avant 1940: Autour de quelques documents nouveaux. *Revue internationale d'histoire de la psychanalyse*, 4, 209–270.
- . (1992). France, 1893–1965. In Peter Kutter (Ed.), *Psychoanalysis international: a guide to psychoanalysis throughout the world*, Vol. 1: Europe (pp. 66–113). Stuttgart, Germany: Frommann-Holzboog.
- . (1996). La scission de la Société psychanalytique de Paris en 1953: quelques notes pour un rappel historique. *Cliniques méditerranéennes*, 49/50, 9–30.
- Mijolla-Mellor, Sophie de. (1998). *Penser la psychose: Une lecture de l'œuvre de Piera Aulagnier*. Paris: Dunod.
- Roudinesco, Élisabeth. (1990). *Jacques Lacan & Co.: A history of psychoanalysis in France, 1925–1985* (Jeffrey Mehlman, Trans.). Chicago: University of Chicago Press. (Original work published in two vols., 1982, 1986.)

## FRANCO DA ROCHA, FRANCISCO (1864–1933)

Francisco Franco da Rocha, Brazilian physician and psychiatrist, was born on August 1864 in Amparo, in the state of São Paulo, Brazil, and died there on April 8, 1933.

Franco da Rocha received his medical degree from the national faculty of medicine of Rio de Janeiro in 1890; he was a student of Teixeira Brandao, com-

monly considered to be the first Brazilian psychiatrist. Upon his return to São Paulo in 1893, Franco da Rocha was named hospital practitioner at the Hospício dos Alienados (a mental hospital created by a state law in September 1848); prior to his arrival, only general practitioners had worked at the facility, and there was no specialization in the treatment of psychiatric patients. Franco da Rocha was thus a pioneering psychiatrist and the first specialist to work in a public institution in São Paulo. In 1896 he was named head physician and director of the Hospício dos Alienados.

That same year he succeeded in establishing an agricultural colony for nearly eighty patients in Sorocaba. This pioneering experiment in the field of work therapy was intended to serve as a pilot for a far more ambitious project: a welfare institution for the mentally ill near São Paulo. Franco da Rocha received government approval for this project and chose as the site a plantation near the railway center of Juquery, the name by which this large psychiatric hospital was first known. Completed in 1902 and since renamed after its founder, the hospital is, as of 2005, still in operation, and many generations of psychiatrists have been trained there. Franco da Rocha served as director of the institution until his retirement in 1923.

Franco da Rocha began his teaching activities in the faculty of medicine of São Paulo in 1913. In 1918 he became that institution's first professor of clinical neuropsychiatry. In his courses, he made the earliest presentations on psychoanalytic doctrine in Brazil. His inaugural lecture in 1919 dealt with Sigmund Freud's psychoanalytic theory. Transcribed and published in the newspaper *O Estado de São Paulo* on March 20, 1919, under the title "Do delírio em geral" (On delusions in general), it marked the beginning of the dissemination of Freudian thought in São Paulo.

In 1920 Da Rocha published *O pansexualismo na doutrina de Freud* (Pansexualism in the doctrine of Freud), a popular scientific work that was well received by the general public but that provoked a discreet negative reaction in medical circles. In 1930, on the advice of Durval Marcondes, he published a second edition of this book in which he eliminated the word *pansexualism*.

According to Marcondes's unpublished biography of Franco da Rocha, "In the presentations he made at this institution, he included a Freudian approach to

mental illness, which at the time was something new for us. This was the beginning, in the scientific circles of São Paulo, of the move from an exclusively descriptive and organicist psychiatry toward a psychiatry that was also becoming descriptive and psychodynamic.”

Although he was a specialist in Freudian doctrine, Franco da Rocha came into contact with it relatively late in his career and was thus unable to incorporate it into his clinical work.

FABIO HERRMANN AND ROBERTO YUTAKA SAGAWA

See also: Brazil.

### **Bibliography**

Briquet, Raul. (1934). *Franco da Rocha e a psicanálise: memórias do Hospital Franco da Rocha*. São Paulo, Brazil.

Franco da Rocha, Francisco. (1928). A psicologia de Freud. *Revista brasileira de psicanálise*, 1: 1.

———. (1930). *A doutrina de Freud* (2nd ed.). São Paulo, Brazil: Companhia Nacional.

Perestrello, Marialzira. (1992a). *A psicanálise no Brasil: encontros psicanálise*. Rio de Janeiro, Brazil: Imago.

———. (1992b). Histoire de la psychanalyse au Brésil des origines à 1937. *Frénésie*, 2 (10), 283–304.

Sagawa, Roberto Yutaka. (1996). *A construção local da psicanálise*. Marília, Brazil: Interior-Psicanálise.

---

## **FRANKL, VIKTOR EMIL (1905–1997)**

Viktor Emil Frankl, Austrian physician, psychoanalyst, philosopher, and professor of neurology and psychiatry at the University of Vienna Medical School, was born on March 26, 1905, in Vienna, where he died of heart disease on September 2, 1997.

Frankl was a twelfth-generation descendant of Rabbi Judah Loew, the Maharal of Prague who created the Golem, Yossele, to save Jews from the blood libel. At sixteen, while still a student at the lycée, Viktor sent Freud a text concerning “the origin of the mimic movements of affirmation and negation” (Frankl, 1997, p. 48), which in 1924 was published in the *International Journal of Psychoanalysis*. But Frankl would turn away from psychoanalytic formulations in favor of the work of Igor Caruso, humanistic psychology, and existential analysis, of which he was a founder.

During the Second World War, Frankl was arrested in September 1942 and spent nearly three years in several concentration camps, including a brief stay at Auschwitz, at Dachau (where he encountered Bruno Bettelheim), and at Theresienstadt. Frankl’s parents, brother, and wife died in the camps. While a prisoner, Frankl drafted a manuscript that was later published as *The Doctor and the Soul*. After being liberated in 1945, he wrote *Ein Psycholog erlebt das Konzentrationslager*, which sold over a million copies when it was published in 1947. Translated in English as *Man’s Search for Meaning*, Frankl drew on his concentration camp experience to develop the theory of “logotherapy,” where *logos* signifies the will to discover meaning in one’s existence.

After the war Frankl was appointed professor of psychiatry at the Vienna Neurological Policlinic. A psychotherapist, he lectured throughout the world and held numerous visiting professorships. In 1970 the first Institute of Logotherapy was founded at the United States International University at San Diego, California. Subsequently, a number of independent institutes were founded and as of 2005 operate in more than 25 countries, including the Viktor Frankl Institute in Vienna. Frankl wrote over thirty books, which have been translated into more than twenty-five languages. “The meaning of your life,” Frankl once explained, “is to help others find the meaning of theirs.”

JACQUES SÉDAT

See also: Austria; Caruso, Igor.

### **Bibliography**

Frankl, Viktor. (1972). *Man’s search for meaning: An introduction to logotherapy*. Boston: Beacon Press.

———. (1997). *Recollections: An autobiography*. New York: Plenum Press.

---

## **FREE ASSOCIATION**

Free association (considered the “fundamental rule”) is the method used in psychoanalytic treatment. In free association the patient says whatever comes to mind without exercising any selectivity or censorship. It is based on Freud’s deterministic concept of psychic phenomena: “We start, as you see, on the assumption, which he does not share in the least, that these

spontaneous thoughts will not be arbitrarily chosen but will be determined by their relation to his secret—to his ‘complex’—and may, as it were, be regarded as derivatives of that complex” (1906c, p. 108–109). The origin of this new method of therapy can be dated from Emmy von N’s irritation with Freud for interrupting her when she spoke. The method was not codified until later and would become the keystone of the technique of psychoanalytic treatment. There is no mention of this in the *Studies on Hysteria*. At that time a pressure on the forehead was intended to bring forth an idea or an image with the help of which the cathartic method could be exercised.

The first mention of the fact that redirecting the patient’s attention can allow connections to emerge between a forgotten word and repressed ideas appears in the analysis of the forgetting of “Signorelli’s” name (1898b). But it is in the chapter on “The Method of Interpreting Dreams” (1900a) that the process is described in detail: “We . . . tell him that the success of the psycho-analysis depends on his noticing and reporting whatever comes into his head and not being misled, for instance, into suppressing an idea because it strikes him as unimportant or irrelevant or because it seems to him meaningless” (p. 101). The technique was used in the analysis of Dora and Freud specifies that he managed to “the pure metal of valuable unconscious thoughts can be extracted from the raw material of the patient’s associations” (1905e, p. 112). For example, “It is a rule of psycho-analytic technique that an internal connection which is still undisclosed will announce its presence by means of a contiguity—a temporal proximity of associations; just as in writing, if ‘a’ and ‘b’ are put side by side, it means that the syllable ‘ab’ is to be formed out of them (p. 39) . . . in a line of association, ambiguous words . . . act like a point at a junction (p. 65n) . . . I am in the habit of regarding associations such as this, which bring forward something that agrees with the content of an assertion of mine, as a confirmation from the unconscious of what I have said (p. 57) . . . [the unwillingness on Dora’s part to follow the rules of dream-interpretation] coupled with the hesitancy and meagreness of her associations with the jewel-case, showed me that we were here dealing with material which had been very intensely repressed” (p. 69n).

It is in “On Beginning the Treatment” (1913c) that Freud made these ideas explicit: “One more thing before you start. What you tell me must differ in one

respect from an ordinary conversation. Ordinarily you rightly try to keep a connecting thread running through your remarks and you exclude any intrusive ideas that may occur to you and any side-issues, so as not to wander too far from the point. But in this case you must proceed differently. You will notice that as you relate things various thoughts will occur to you which you would like to put aside on the ground of certain criticisms and objections. You will be tempted to say to yourself that this or that is irrelevant here, or is quite up important, or nonsensical, so that there is no need to say it. You must never give in to these criticisms, but must say it in spite of them—indeed, you must say it precisely because you feel an aversion to doing so. Later on you will find out and learn to understand the reason for this injunction, which is really the only one you have to follow. So say whatever goes through your mind. Act as though, for instance, you were a traveler sitting next to the window of a railway carriage and describing to someone inside the carriage the changing views which you see outside. Finally, never forget that you have promised to be absolutely honest, and never leave anything out because, for some reason or other, it is unpleasant to tell it” (p. 135).

This method of free association was often confused with the association experiments involving stimulus words that Eugen Bleuler and Carl Gustav Jung were doing at the same time at the Burghölzli clinic. Even though he referred to the method in “Psycho-Analysis and Establishment of Facts in Legal Proceedings” (1906c), Freud was careful to differentiate his own work from it and, on February 26, 1908, referred to this technique as a “coarse method, to which psycho-analysis is far superior” (Nunberg and Federn, 1962–1975, p. 335). But for years commentators, especially in France, have attributed its use to him.

In 1920, in “A Note on the Prehistory of the Technique of Analysis,” Freud recognized the “cryptamnesia” that led to his claiming to be the inventor of a method, a description of which he had read when he was fourteen in a text by Ludwig Börne, entitled, “The Art of Becoming an Original Writer in Three Days.” In it he stated that the best way for the writer to banish inhibitions and censorship was to write down everything that came to mind for a period of three days.

Once again we see how an isolated idea that circulates in the popular mind is inadequate on its own and what developments are needed for it to be integrated

within a body of thought that transcends it. The method of free association, by freeing speech in its search for a hidden truth, has become the principal method of producing the material for analysis, even if, through overproduction, the freedom it offers sometimes becomes a form of resistance to any form of interpretation.

ALAIN DE MIJOLLA

*See also:* Active imagination (analytical psychology); Complex; Evenly-suspended attention; Framework of the psychoanalytic cure; Hermeneutics; Technique with adults, psychoanalytic; Sudden involuntary idea; Word association (analytic psychology).

### **Bibliography**

- Freud, Sigmund. (1906c). Psycho-analysis and the establishment of facts in legal proceedings. *SE*, 9: 103–114.
- Nunberg Hermann, and Federn, Ernst. (1962–1975). *Minutes of the Vienna Psychoanalytic Society*. New York: International Universities Press

---

## **FREE ENERGY/BOUND ENERGY**

Freud regarded energy as a capacity with two modes of functioning: that of free energy, in which energy proceeds towards an immediate and total discharge, and that of bound energy, in which it is blocked and accumulates.

Freud used the concept of energy in his theory in an attempt to explain a point of transition between the “quantity” of energy and the “quality” of the representation. To this end, he addressed the question of energy in the “Project” (1950a; Laplanche and Pontalis, 1967/1974; Laplanche, 1976) in a far more radical way than Josef Breuer had done. There he described “primary process” as an energetic state of disorganization that the ego on its emergence seeks to regulate during the “secondary process” by managing the energy according to the constancy principle.

As concerns energy, however, the distinction clearly does not always work perfectly for Freud because in this text he only used this term twice and without the qualification “bound” or “free.” Although Freud’s idea of energy used the inevitably sexual encounter between the child and the adult as a metaphor here, unfortunately he combined this with

a genetic perspective in which primary-process disorganization precedes the organization that characterizes the secondary process. Accordingly, this hierarchical Jacksonian perspective prevented him from the outset from fully conceiving of the primary process as the result of the absorption of adult sexuality into the child’s psychic apparatus.

It should also be noted that with its excessively cut-and-dried oppositions, the dynamics posited by Freud are no more satisfactory in relation to the matter of life. In Freud’s concept of the child, he has no chance of survival, whether this is in terms of an excessively organized or an excessively withdrawn system. The latter perspective very clearly leads to the theory of narcissism, while the former leads to the conceptualization of the death drive.

In *The Interpretation of Dreams* (1900a), Freud reattributed the role of binding to the preconscious. It is also here that the expression “cathexing energy” appears, described as “mobile and capable of discharge” (p. 597), which conflicts with the theories of the “Project,” in which cathexis had been conceived as a way of producing bound states. In fact, this concerns an energy in search of representations and, furthermore, an “object.” The cathexis of energy is next conceived (1915d) as an approach to the unconscious and its decrease (decathexis) is attributed to repression. In “The Unconscious” (1915e), Freud stated that Breuer had distinguished between “two different states of energy in mental life; one in which energy is tonically ‘bound’ and the other in which it is freely mobile” (p. 188). In fact, Breuer (1895d) had superimposed on psychic states two types of energy that accorded with the knowledge of the time but which Freud had gone on to use in a much more imaginative way. In *Beyond the Pleasure Principle* (1920g), still unaware of a further distortion, Freud also attributed the idea to Breuer by maintaining that he had established the distinction between “two kinds of cathexis of the psychical systems or their elements—a freely flowing cathexis that presses on towards discharge and a quiescent cathexis” (p. 31).

Freud thus established the foundation for his theory of a death drive that unbinds and an Eros that binds. This could be considered as a diluted view of sexuality, simultaneously binding and unbinding, which he had encountered from his first analyses. The main impetus for this development may be the

theory of narcissism in which Freud had exalted the theme of happiness found in love of the external object, a theme that had already appeared in embryonic form in the “Project,” with its Jacksonian perspective of a possible transition from unbinding to binding.

In conclusion, Freud did not succeed in resolving the question of free energy or framing it in dialectic terms because it simultaneously applied to both conscious (1933a [1932]) and unconscious functioning. The theoretical problem arises, in terms of the conscious, from the perception that leaves no trace and, in terms of the unconscious, from the primary process. If free energy cannot be specific, the solution would be to remove the distinction between free and bound energy because this adventitious hypothesis, since Breuer’s proposition, has confused energy and state. In fact, a system that possesses what can be (wrongly) described as a disordered state can operate with the same energy as an ordered system.

BERTRAND VICHYN

*See also:* Psychic energy.

### **Bibliography**

- Freud, Sigmund. (1900a). The interpretation of dreams. *SE*, 4–5: 1–625.
- . (1915d). Repression. *SE*, 14: 141–158.
- . (1915e). The unconscious. *SE*, 14: 159–204.
- . (1920g). Beyond the pleasure principle. *SE*, 18: 1–64.
- . (1933a). New introductory lectures on psychoanalysis. *SE*, 22: 1–182.
- . (1950a). Extracts from the Fliess papers. *SE*, 1: 173–280.
- Freud Sigmund, and Breuer, Josef. (1895d). Studies on hysteria. *SE*, 2: 48–106.
- Laplanche, Jean. (1976). *Life and death in psychoanalysis* (Jeffrey Mehlman, Trans.). Baltimore, MD: Johns Hopkins University Press.
- Laplanche, Jean, and Pontalis, Jean-Bertrand. (1974). *The Language of Psycho-Analysis* (Donald Nicholson-Smith, Trans.). New York: Norton. (Original work published 1967)

---

**FREE-FLOATING ATTENTION.** *See* Evenly-suspended attention

---

**FREUD, ALEXANDER GOTTHOLD EFRAIM.** *See* Freud, Sigmund (siblings)

---

### **FREUD, ANNA (1895–1982)**

Psychoanalyst and pioneer in child analysis, Anna Freud was born on December 3, 1895, in Vienna, and died on October 9, 1982, in London.

Anna Freud was Sigmund and Martha Freud’s third daughter and sixth and last child. When she was a year old, Martha’s sister Minna joined the family. The two women had carefully defined roles, but a warm and affectionate Catholic nursemaid, Josefine Cihlarz, to whom Anna felt very close, took a very active part in the upbringing of the three youngest children. The children were treated leniently but firmly: disciplined behavior and punctuality were emphasized and expected. Anna Freud displayed these traits throughout her life. Her love of animals may, in part, have reflected Josefine’s influence.

She started elementary school at six, and at ten entered the Salka Goldman Cottage Lyceum for girls. She read widely and wrote poetry. Her remarkable memory was a major asset at school and throughout her life; later, as a psychoanalyst, she never forgot the details of any case reported to her, and could make telling use of them in clinical discussion.

She was on holiday in England when war broke out in 1914. Now an enemy alien, she managed to return to Austria with the Ambassador and his entourage, traveling by an adventurous route. She trained as an elementary school teacher at the Lyceum, and her industry and rare intelligence ensured her appointment to the teaching staff.

She was always a wonderful teacher, but her interest in psychoanalysis was evident in early adolescence. She became Librarian of the Viennese Psychoanalytic Association, and was analyzed by her father—unthinkable perhaps nowadays, but not such a rare event at this time. She read her first paper (on beating fantasies) to the Association in 1922, and was thereby granted membership.

Her teaching experience served her well as a pioneer in child analysis. Melanie Klein was already analyzing children in Berlin; but the two leaders in the field used children’s play differently in their techni-

ques. Anna Freud disputed Klein's belief that play was the child's equivalent of free association in adults, but this was only one of many later differences. Klein went to England in 1927 and became a powerful influence in the British Society. Disparities of view between the Viennese and British Societies became pronounced, initially on the basis of child analytic practice.

Anna Freud's new ideas, charm, and lifelong capacity for winning collaborators quickly secured her a large following. Her seminars in Vienna attracted colleagues from Prague and Budapest. A wide range of disorders were treated and discussed, but Anna Freud's attention to normal development matched her interest in pathology. She believed it was impossible to understand the one without the other. She applied her growing knowledge to the field of education and gave lectures to teachers and parents. With her friend and colleague Dorothy Burlingham, she set up what she called "a cross between a crèche and a nursery school," financed by the wealthy psychoanalyst Edith Jackson, for the poorest children in Vienna who were given both bodily and psychological care. These experiences fuelled Anna Freud's interest in the psychological consequences and concomitants of physical illness and laid a foundation for her interest in pediatric practice.

Her work with adults fostered her need to know more about psychiatry and she attended, on a regular basis, ward-rounds at the University's Psychiatric Clinic, headed by Wagner-Jauregg, the Nobel Prize winner, and staffed by Paul Schilder and Heinz Hartmann. She retained this interest for the rest of her life.

Earlier publications were followed by her first book in 1936, appearing one year later in English as *The Ego and the Mechanisms of Defence*. This major work was the first to distinguish between recognized defenses against instinctual drive derivatives and defenses against painful affects, newly observed and described by her.

The Nazis annexed Austria in 1938, and Princess Marie Bonaparte and Ernest Jones together secured safe transfer to London for the Freud family and a number of associates. Freud, Anna, and other psychoanalysts were admitted to the British Psycho-Analytical Society. Though well received, clinical and theoretical differences between the two groups were

pronounced and culminated in a series of controversial discussions between 1941 and 1945. The disagreements were beyond resolution, and two parallel training courses were set up in recognition of this fact.

Freud died in 1939 from the cancer of the jaw that had plagued him for fourteen years, and Anna Freud was his devoted nurse. She continued to support the principles behind his psychoanalytic thinking, but she had a highly original mind and never followed him slavishly. After the outbreak of war, the predicament of children made homeless through bombing led her to establish, with Dorothy Burlingham, the Hampstead War Nurseries. Careful observations and meticulous records, made with the help of staff who rarely left the premises, vastly increased existing knowledge of child development and problems of residential care. The findings are collected by Anna and Dorothy in *Young Children In Wartime* (1942) and *Infants Without Families* (1944).

In 1947 Anna Freud founded a course in child analysis, and in 1952 established the Hampstead Child Therapy Clinic. With these unequalled facilities clinical research expanded substantially. In this Anna Freud's charm and authority served her unsurpassed capacity to draw staff and students into the work and make substantial contributions. She herself continued to publish major papers, but her most important book was *Normality and Pathology of Childhood* (1965). Her writing continued apace, with major contributions to psychoanalytic diagnosis and to clinical and theoretical understanding of a wide range of developmental problems and disturbances. Her work in the fields of education, pediatrics, and family law (*Beyond the Best Interests of the Child*), in which she collaborated with Professors Albert J. Solnit and Joseph Goldstein from Yale University, won her wide recognition within those disciplines. She received many honors and was appointed Commander of the British Empire (CBE) in 1967. Of her many honorary degrees, she was especially proud of the MD from the University of Vienna (1975) and the PhD from the Goethe Institute in Frankfurt (1981) where, half a century earlier, her father had been awarded the Goethe prize for literature.

By this time Anna Freud was seriously ill with an advanced anemia of old age, but her mind remained clear and active throughout the slow physical deterioration that led to her death. Her ashes were

placed next to her father's at Golders Green crematorium in London.

CLIFFORD YORKE

*Work discussed: Ego and the Mechanisms of Defence, The.*

*See also:* Abandonment; Adaptation; Adolescent crisis; Altruism; Andreas-Salomé, Louise (Lou); Austria; Berggasse 19, Wien IX; British Psycho-Analytical Society; Burlingham-Rosenfeld/Hietzing Schule; Burlingham-Tiffany, Dorothy; Childhood; Children's play; Child psychoanalysis; Controversial Discussions; Defense; Ego (ego psychology); Externalization-internalization; First World War: The effect on the development of psychoanalysis; Freud-Bernays, Martha; Freud Museum; *Freud, the Secret Passion*; Lay analysis; *Gesammelte Schriften*; *Gesammelte Werke*; Gestapo; Goethe (prize); Great Britain; Hampstead Clinic; Hogarth Press; Identification with the aggressor; *Imago. Zeitschrift für die Anwendung der Psychoanalyse auf die Geisteswissenschaften*; Infantile neurosis; Lehrinstitut der Wiener psychoanalytischen Vereinigung; Masochism; Negative transference; Neutrality/benevolent neutrality; Phobias in children; *Psychoanalytic Study of the Child, The*; Second World War: The effect on the development of psychoanalysis; Sigmund Freud Archives; Sigmund Freud Copyrights Limited; Sigmund Freud Museum; Splits in psychoanalysis; *Standard Edition of the Complete Psychological Works of Sigmund Freud*; Telepathy; Transference in children; Unconscious fantasy; Wiener psychoanalytische Vereinigung.

### Bibliography

- Freud, Anna. (1936). *Collected writings*. New York: International Universities Press.
- . (1968). Acting out. *International Journal of Psycho-Analysis*, 49.
- . (1977). Fears, anxieties, and phobic phenomena. *Psychoanalytic Study of the Child*, 32, 85–90.
- . (1979). Personal memories of Ernest Jones. *International Journal of Psycho-Analysis*, 60, 285–287.
- . (1980). Introduction. In Sigmund Freud: *The analysis of a phobia in a five-year-old boy*. Frankfurt am Main: S. Fischer.
- . (1981). Insight. *Psychoanalytic Study of the Child*, 36, 241–250.
- Goldstein, Joseph; Freud, Anna; and Solnit, Albert J. (1973). *Beyond the best interests of the child*. New York: The Free Press.

## FREUD-BERNAYS, MARTHA (1861–1951)

Martha Bernays was born on July 26, 1861, the second daughter of Berman Bernays (1826–1879), a merchant, and his wife Emmeline (née Philipp, 1930–1910). Isaac Bernays, Martha's paternal grandfather, was Chief Rabbi of Hamburg, and Berman continued the religious tradition. Emmeline Bernays was intelligent, resolute, well-educated, and shared Berman's Jewish orthodoxy. Martha obeyed her with true devotion. Berman moved to Vienna in 1869 as secretary to a well-known economist. Emmeline loved Hamburg and disliked the move. On December 9, 1879, Berman died suddenly of a heart attack. Martha became an intelligent young woman without intellectual pretensions, svelte, attractively pale, and gracious, and she had a warm personality that brought many male admirers.

Freud met Martha in April 1882; though previously uninvolved with women, he quickly fell in love. His great passion (it was nothing less) was more slowly returned by Martha, but with unwavering steadfastness, and they were soon engaged. The betrothal was secret at first, since Freud was without the means to support a wife. The engagement is well documented by Ernest Jones (1953), who was privileged to read, in their entirety, the love letters that almost daily passed between them. Jones declared that the vast set of letters "would be a not unworthy contribution to the great love literature of the world."

During the engagement (1882–1886) Freud was at times despairing, both because of his poverty and his agonizing attacks of jealousy, not only of men Martha knew, but even of her mother and brother. Martha, by contrast, was unchangingly certain of Freud's love. Freud's eldest sister Anna became engaged to Martha's brother, Eli, at Christmas 1882, and Freud and Martha then declared their own commitment. The hardest tribulation came in June, when Emmeline returned to her former home at Wandsbek, near Hamburg, and Martha, protesting, went with her. Freud had been obliged to give up research work, and was struggling to establish a private practice. Finally, their civil wedding, on September 13, 1886 at Wandsbek, was not recognised in Austria, where a Jewish marriage was obligatory, much to Freud's distaste. In spite of her upbringing, Martha joined Freud in his religious antipathy, and Jewish practices formed no part of their life together.

The honeymoon was largely spent in Holstein on the Baltic, and the bride, just 25, and the husband, 30, settled in Vienna at 8 Maria Theresienstrasse. Their first child, Mathilde, arrived on October 16, 1887. The marriage was remarkably happy, with no return of Freud's early, intermittent doubts of Martha's love. Martha was an excellent wife and mother; both were devoted parents. Two sons were born: Jean Martin (after Charcot) on December 6, 1889, and Oliver (after Cromwell) on February 19, 1891. More space was needed, and it was at 19 Bergasse that the three remaining children were born: Ernst (after Brücke) on April 6, 1892; Sophie on April 12, 1893; and Anna (after Freud's sister) on December 3, 1895. Josefina Cihlarz, a Catholic *Kinderfrau*, then looked after Anna, Sophie and Ernst. About a year later, Martha's sister Minna, whose fiancé had died, joined the family.

Minna differed from Martha in both looks and temperament: large as opposed to petite; a little imperious as opposed to retiring; outspoken as opposed to discrete. But they got on well enough, and ran the home with clear boundaries between responsibilities. Freud found Minna an intellectual companion who, unlike Martha, took an interest in his developing psychological theories. Martha made it her duty to facilitate Freud's professional work with a supportive daily routine, and their mutual devotion was unshakeable. Martha read widely and discussed with her husband the major works she read. They quoted poetry together—by Goethe, Heine, Uhland and others. Martha, whose letters were sometimes in verse, kept up with current literature to the end of her life. She entertained well; and distinguished visitors included Thomas Mann, one of her favorite authors.

There were misfortunes in the family. Martha was severely ill in 1919, and in the following year Sophie's death from a similar illness was a bitter blow. Many years later the savage disruption of the *Anschluss*, on March 11, 1938, signalled the end of life in Vienna. Through the good offices of Marie Bonaparte and Ernest Jones the family able to move to London, and accorded diplomatic privileges. Eventually, Martha, Sigmund Freud, and Anna settled for good at 20 Maresfield Gardens. Dorothy Burlingham was unable to join for some time; Paula Fichtl, the maidservant, was first interned in the Isle of Man; and Minna was soon admitted to a nursing home.

Martha was efficient in the home even without Paula's help. She did the shopping daily, became well

known to the local shopkeepers, and remained a hostess of considerable charm to the many visitors. Although Martha was deeply worried about Freud's health, it was Anna who nursed him, making his care a duty above all others. By March 1939 he began to deteriorate, and died on the 23 September, 1939.

In a response to Margarethe Nunberg's condolences, Martha said they would have to live without his goodness and wisdom (Young-Bruehl, 1988). In spite of all her children's love, and support from all over the world, her life, she said, had lost its sense and meaning.

Minna died in 1941, and Martha's sense of loneliness intensified. At the end of the war came the horrific news of the deaths of members of the Freud family in concentration camps, of which, hitherto, there had been no intimation. Bereaved relatives were accommodated and comforted at Maresfield Gardens.

In due course Martha became chronicler of the lives of herself and her husband, and as such, a unique resource for biographers, though family letters remained private. She wrote to friends worldwide, and composed short poems for family occasions. She stayed in charge of home and garden but, increasingly frail as she approached ninety, needed home nursing. She died on November 2, 1951.

CLIFFORD YORKE

*See also:* Berggasse 19, Wien IX; Bernays, Minna; Freud, Anna; Freud, Ernst; Freud, Oliver; Judaism and psychoanalysis.

### **Bibliography**

- Jones, Ernest. (1957). *Sigmund Freud. Life and work*. London: Hogarth.
- Young-Bruehl, Elizabeth. (1988). *Anna Freud: A biography*. New York: Summit Books.

---

## **FREUD, EMMANUEL** *See* Freud, Sigmund (siblings)

---

## **FREUD, ERNST (1892–1970)**

Ernst Freud was born on April 6, 1892, in Vienna and died April 7, 1970, in London. The fourth of six children of Sigmund and Martha Freud, he was named in honor of Ernst Brücke. As a child there were references



to him in his father's correspondence, where Sigmund Freud discussed the child's angina and various fevers. On June 12, 1900, Freud wrote, "Ernst had a fever again for four days. He has unflagging energy, even with a 38.5 [°C] fever he continues to cry out: I won't be able to get well, I want to get up; it was only at 39.5 [°C] that this cantankerous fellow took note and became amiable."

He seems not to have been overly influenced by his father's fame and chose his profession without interference. On June 15, 1909, Freud wrote to Oskar Pfister, "Ernst, who was your favorite and has almost become ours, is taking his final examination, although he is suffering from an ulcer of the small intestine and is not doing well at all. He wants to become an architect. I don't know if I'm supposed to agree with this." In fact he did become an architect, though he was often referred to as the "fortunate child" or, as Freud wrote to his friend Max Eitingon in London in 1938, "a tower of strength."

A militant Zionist, he participated in the Zionist Congress held in September 1913 in Vienna. Along with his brother Martin, he joined the army in 1914; he left for Galicia in August 1915 but returned a year later on leave to see his family, "as sprightly as ever." He was demobilized without problem but suffered for years from the results of pneumonia contracted during the war.

After the war he completed his studies at the Munich Technische Universität and, in December 1919, settled in Berlin, where he became engaged to Lucy Brasch, marrying her shortly afterward ("Lux," 1896–1989). "To all appearances a good and beautiful creature," Freud wrote to Lou Andreas-Salomé. That same year Karl Abraham had, on March 13, told his father that Ernst "had attained lasting merit in setting up the clinic [and would be] universally admired."

Ernst and Lucy's first child, Stefan (Stephen) Gabriel, was born July 31, 1921, "He is my fourth grandson, but I regret the absence of a grand-daughter," Freud wrote to Ernest Jones, who wrote back, "I was delighted to learn that Ernst has a son: a new acquisition for Zionism." Lucy, who was not Jewish, "had been so sure of having three sons that she decided from the beginning to give each of them the name of an archangel in addition to a more earthly first name." (Jones, 1959, III) There followed Lucian Michael on December 8, 1922, who became a well-known painter, a friend of Francis Bacon, and of Klemens (Clement)

Raphael, who was known in Great Britain as a television host, a specialist in gastronomy, and a deputy in the Liberal Party. Freud met these friends for the first time in Berlin during Christmas 1925, and it was in Berlin, while staying with his son, that he was visited by Albert Einstein and his wife.

The "architect," as Ernst was known, helped renovate the Tegel clinic between 1927 and 1928. It was also in 1928 that he worked on the Berlin Psychoanalytic Institute. On October 22, 1930, Freud wrote to Lou Andreas-Salomé, "Today, I gave my son Ernst the order to send you a thousand marks from the Goethe prize money he is holding for me."

In 1933 the rise of Nazism forced Ernst to emigrate, in spite of the fact that "he was sheltered because of his wife," as Freud wrote to Jones. Moreover, it was because of his wife that he chose Great Britain, where he arrived during the summer. On June 3, 1933, Jones told Sigmund, "We were able to provide Ernst with good introductions and he has certainly lived up to his reputation as being a *Glücksind* (lucky person). You have nothing to worry about as far as he is concerned. We will be delighted to have him in England, even though I have wondered if, with his bubbly personality, he wouldn't be better off in France."

His integration in British society was not without difficulties, in spite of the help of Jones, who commissioned him to build a wing for his cottage in 1935–1936. On October 14, 1937, Arnold Zweig wrote to Freud, "I need to get in touch with you and let you know that I was pleased with my visit to your Ernst in London. He is tranquil, serene, and full of juvenile enthusiasm, and his home is delightful in its nobility and simple modernity."

Ernst traveled to Paris to meet his parents when they arrived in June 1938 and was also close by when they settled in London. Together with his sister Anna, he found the house in Maresfield Gardens, where he had an elevator installed, which Freud needed to reach his bedroom.

At the time of his father's death, he was, with Martin and Anna, appointed an executor of the will. He ran the corporation that was formed to manage the rights for Freud's work and, with Lucy's assistance, worked on all the major Freud publications that were to help popularize his work and psychoanalysis in general after the 1950s: his correspondence with Wilhelm Fliess (1950a), his general correspondence (1960a),

and so on. Shortly before his death, in late 1969, he had the pleasure to be given by Franz Jung, also an architect, the letters that had been kept by his father “in a document box covered with linen cloth, on which had been written in large capital letters, ‘FREUD LETTERS.’”

Ernst Freud died on April 7, 1970. After his death, Ilse Grubrich-Simitis was asked to complete the pictorial biography he had planned to publish and on which he had worked with Lucy. The work finally appeared in 1976 as *Sigmund Freud: His Life in Pictures and Words*.

ALAIN DE MIJOLLA

See also: Berggasse 19, Wien IX; Berliner Psychoanalytisches Institut; Freud-Bernays, Martha; Sigmund Freud Copyrights Limited.

### **Bibliography**

Berthelsen, Detlef. (1989). *Alltag bei Familie Freud. Die Erinnerungen der Paula Fichtl*. Hamburg: Hoffman & Campe.

Gay, Peter. (1988). *Freud: A life for our time*. London-Melbourne: Dent.

Jones, Ernest. (1959). *Free associations. Memories of a psycho-analyst*. London, New York: Basic Books.

Roazen, Paul. (1993). *Meeting Freud's family*. Amherst: University of Massachusetts Press.

---

**FREUD, ESTHER ADOLFINE (DOLFI).** See **Freud, Sigmund** (siblings)

---

### **FREUD, JAKOB KOLLOMAN (OR KELEMEN OR KALLAMON) (1815–1896)**

Jakob Freud, the father of Sigmund Freud, was born on April 1, 1815, (a date arbitrarily chosen by Jakob Freud) in Tysmenitz (Galicia) and died in Vienna on October 23, 1896. Of his father's family Freud wrote, “I believe they lived a long time in Rhenish territory (Cologne), that during the persecution of Jews in the fourteenth or fifteenth century they fled east, and in the nineteenth century returned from Lithuania, through Galicia, to a German-speaking country, Austria” (1925d).

In the “Gedenkenblatt,” where he entered the birth date of May 6, 1856, and circumcision on May 13 of

the following year of “my son Schlomo Sigmund,” Jakob Freud refers to his grandfather “Rabbi Ephraim” and his father “Rabbi Schlomo,” who died in Tysmenitz on February 21, two months prior to the birth of Freud, who was given the same first name. The sources of Freud's unconscious identifications (Mijolla, 1975/1981 [1975]) have been traced to the references to honorifics appearing in this genealogy.

The son of Schlomo Freud and Peppi (Pesel) Hofmann, Jakob had, out of admiration for Bismarck, chosen the date of April 1 as his birth date, although in reality the date is assumed to be December 18, 1815. Born in Tysmenitz, Galicia, he was the eldest of four children. His younger brother Josef (1825–1897), arrested in 1865 and condemned in February 1866 to ten years in prison for trafficking in counterfeit rubles (Gicklhorn, 1976), was the “criminal” uncle (*Verbrecher*) who appeared in the *Interpretation of Dreams* and caused so much grief for his older brother.

Freud wrote to his fiancée about another “uncle from Breslau,” Abae. “He is a younger brother of my father, a rather ordinary man, a merchant, and the story of his family is very sad. Of the four children only one daughter is normal, and married in Poland. One boy is hydrocephalic and feeble minded; another, who as a young man showed some promise, went insane at the age of nineteen, and a daughter went the same way when she was twenty-odd. I had so completely forgotten this uncle that I have always thought of my own family as free of any hereditary taint. But since I have been thinking about Breslau it all came back to me, and I am afraid the fact that one of the sons of the other (very unhappy) uncle in Vienna died an epileptic is something I cannot shift to the mother's side, with the result that I have to acknowledge to a considerable ‘neuropsychological taint,’ as it is called” (letter of February 10, 1886).

Jakob married young, in 1832. His wife was Sally Kanner and together they had four children, two of whom survived. The elder, Emanuel, was born in 1833 (or 1832), followed by Philipp, born in 1836 (or 1834). A fabric salesman, there are references to a trip Jakob is supposed to have made with his father Schlomo and maternal grandfather Siskind Hoffmann to Freiberg in 1838–1839, then of extended stays in 1844–1845 as “tolerated Jews.” He spent several months there before joining his family in Tysmenitz, then received the authorization to settle in Klogsdorf, near Freiberg, in 1848. In the “register of Jews,” there is a record from

October 31, 1852, that at their home are: Jakob Freud, thirty-eight, with his wife Rebeka, thirty-two, and the children, Emanuel, twenty-one, with his wife, eighteen years, and Filip, sixteen” (Sajner, 1968; Gicklhorn, 1976). Mention of this “Rebeka,” rather than “Sally” has led to much wild speculation, but it is possible that because of an administrative error or for reasons of concealment, the entry refers to the wife of his brother Joseph, Rebecca Freud-Rawnial.

Whoever this “Rebeka” may have been, Jakob was no longer married when he met Amalia Nathanson, twenty-one years his junior. They were married according to the Jewish rites in Vienna, on July 29, 1855, before settling in Freiberg in the house at Schlos-sergasse 117, owned by the locksmith Zajic. In 1857 his wife was referred to as “the wife of the wool draper” (*Wollhändlersgattin*).

There followed six births in ten years: Sigmund, on May 6, 1856; Julius, in October 1857, who died the following April; Anna, on December 31, 1858; Regine Debora (Rosa), on March 21, 1860; Maria (Mitzi), on March 22, 1861; Esther Adolfine (Dolfi), on July 23, 1862; Pauline Regine (Paula), on May 3, 1864; and Alexander Gotthold Efraim, on April 15 (or 19), 1866.

Over this period Jakob’s situation changed. Poor business decisions forced him to emigrate to Leipzig, and then to Vienna, where he settled permanently. His sons left for Manchester, England, where they became prosperous businessmen; his wife and their two first children joined him in August 1859. Establishing a permanent residence in Vienna turned out to be extremely difficult, and bad memories of this period stayed with Sigmund Freud throughout his life.

From this point on nothing is known of Jakob’s activities or the source of his income, which, although modest, allowed him to raise his large family and enabled Sigmund—the talented son he so admired—to attend school without having to earn a living to help the family. This mystery became the source of several malicious assumptions when the counterfeiting operations of Uncle Josef were revealed. The investigation led all the way to Manchester, although no evidence was found incriminating Jakob or his two émigré sons.

A tall man, who according to his son resembled Garibaldi, Jakob was a calm and respected patriarch. An observant Jew close to the Haskala movement, he appears to have been more traditional than Freud claimed. Although it is not known if Sigmund himself

was bar-mitzvahed, he learned to read with the Philippson Bible, which was presented to him on his thirty-fifth birthday with a dedication in Hebrew: “My dear son Schlomo (Salomo), in the seventh . . . [illegible] of your life, the spirit of the Lord began to move you [cf. Judges, 13:25], and said to you: Go, read in My book that I have written, and there will be opened to you the sources of wisdom, or knowledge and understanding . . . For a long time the book has been hidden [kept safe] like the fragments of the Table of the Law in the shrine of his servant, [yet] for the day on which you have completed your thirty-fifth year I have had it covered with a new leather binding and given it the name ‘Spring up, O Well! Sing ye unto it’ [cf. Numbers 21:17], and offer it to you for a remembrance and a memorial of love—From your father, who loves you with unending love—Jacob son of Rabbi [probably “Reb,” meaning Mr., M.K.] Sch. Freud. In the capital city of Vienna, 29 Nissan 5651, May 6, 1891” (Krull, 1979, p. 160).

Martin Freud, his grandson, recalls his amiable nature, and his granddaughter, Judith Bernays-Heller, recalls, “[He] divided his time between reading the Talmud (in the original) at home, sitting in a coffee house, and walking in the parks. . . . Tall and broad, with a long beard, he was very kind and gentle, and humorous in the bargain—much more so than my grandmother. . . . It was not a pious household, but I do remember one Seder at which I, as the youngest at the table, had to make the responses to the reading of the song about the sacrifice of the kid. I was greatly impressed by the way my grandfather recited the ritual and the fact that he knew it by heart amazed me.” (1973, p. 336).

For Sigmund, the son, things were less simple. There are references in *The Interpretation of Dreams* to his reprimands, his irritated comment, “Nothing will ever come of this boy,” the reproaches for his expenditures on books. On several occasions he attributes his father’s compulsion for earning money to his poor financial management. For example, on December 18, 1916, he wrote to Karl Abraham, “I have little to do, so that at Christmas, for instance. I am again faced with a blank. Leisure is not good for me, because my mental constitution urgently requires me to earn and spend money on my family as the fulfillment of my well-known father complex” (1965a).

He also remembered being terribly disillusioned by the sight of his father, without saying a word, picking

up a hat thrown into the mud by an anti-Semite. But during the republication of the book in 1908, Freud recognized, “I understood that it was part of my self-analysis, my reaction to the death of my father, the most important event, the most terrible loss in a man’s life.”

In fact, after his father’s illness, which began in June 1896, and his death on October 23, Freud wrote to Wilhelm Fliess, “He bore himself bravely to the end, just like the altogether unusual man he had been” (letter dated October 26, 1896), and “By one of those dark pathways behind the official consciousness the old man’s death has affected me deeply. I valued him highly, understood him very well, and with his peculiar mixture of deep wisdom and fantastic light-heartedness he had a significant effect on my life. By the time he died, his life had long been over, but in [my] inner self the whole past has been reawakened by this event. I now feel quite uprooted” (letter to Wilhelm Fliess, November 2, 1896).

However, on February 8, 1897, he remarked, “Unfortunately, my own father was one of these perverts and is responsible for the hysteria of my brother (all of whose symptoms are identifications) and those of several younger sisters. The frequency of this circumstance often makes me wonder.” We know that the doubt would disappear during his self-analysis, which began in July, and Freud could write, on September 21, “I no longer believe in my *neurotica* [theory of the neuroses]” after being confronted by his “surprise that in all cases, the *father*, not excluding my own, had to be accused of being perverse.” On October 3, shortly before the anniversary of Jakob’s death, he confirmed, “the old man plays no active part in my case.”

But the history of psychoanalysis bears witness to the fact that Jakob Freud did play a role in the genesis of Freudian theory and the place given in it to the representation of the father. And it was to him that, in 1904, standing on the Acropolis with his brother Alexander, Sigmund Freud’s thoughts turned, “It must be that a sense of guilt was attached to the satisfaction in having gone such a long way: there was something about it that was wrong, that from the earliest times had been forbidden. It was something to do with a child’s criticism of his father, with the undervaluation which took the place of the overvaluation of earlier childhood. It seems as though the essence of success was to have got further than one’s father, and as though to excel one’s father. . . . Our father had been in

business, he had no secondary education, and Athens could not have meant much to him. Thus what interfered with our enjoyment of the journey to Athens was a feeling of *filial piety*” (1936a).

ALAIN DE MIJOLLA

### Bibliography

- Bernays-Heller, Judith. (1973). Freud’s mother and father. In *Freud as we knew him* (pp. 334-340). Detroit: Wayne University Press.
- Bernfeld, Siegfried, and Cassirer-Bernfeld, Suzanne. (1944). Freud’s Early Childhood. *Bulletin of the Menninger Clinic*, VIII, 107–115.
- Freud, Sigmund. (1900a). The interpretation of dreams. Part I. *SE*, 4: 1–338; The interpretation of dreams. Part II., *SE*, 5: 339–625.
- . (1936a). A disturbance of memory on the Acropolis (An open letter to Romain Rolland on the occasion of his seventieth birthday). *SE*, 22: 239–248.
- Freud Sigmund, and Abraham, Karl. (1965a). *A psycho-analytic dialogue: The letters of Sigmund Freud and Karl Abraham, 1907-1926* (Hilda C. Abraham and Ernst L. Freud, Eds.; Bernard Marsh and Hilda C. Abraham, Trans.). New York: Basic Books.
- Gicklhorn, Renée. (1976). La famille Freud à Freiberg. *Études freudiennes*, 11–12, 231–238.
- Krüll, Marianne. (1979). *Freud and his father* (Arnold J. Pomerans, Trans.). New York: W. W. Norton.
- Sajner, Josef. (1968). Sigmund Freuds Beziehungen zu seinem Geburtsort Freiberg (Pribor), und zu Mähren. *Clio Medica*, 3, 167–180.

### FREUD, (JEAN) MARTIN (1889–1967)

Martin Freud, a lawyer and the eldest son of Sigmund Freud, was born on December 6, 1889, in Vienna, and died in 1967 in London. He was named Jean Martin in honor of Charcot. Writing to Freud, Charcot exclaimed, “Best wishes; may he be welcomed; may the Evangelist and the generous Centurion be propitious for him; may their names, which are now his as well, bring him happiness!” Later he dropped “Jean” from his name. Sigmund Freud considered his son Martin to be “very intelligent” and in his letters to Wilhelm Fliess, along with news about childhood illness, he made several references to the poems the boy wrote between the ages of eight and ten. He was “a strange

bird; sensitive and good-natured in his personal relationships, completely wrapped up in a humorous phantasy world of his own.” (letter dated July 3rd, 1899, 1985c, p358). This lightheartedness would remain with him all his life.

After completing his “matura” (equivalent to the first year of college) in 1908, he entered the university to study law. An enthusiastic sportsman, “he had his face cut in a duel,” as Freud informed Carl Gustav Jung on July 7, 1909. He was also politically engaged and had joined a Zionist movement, the Kadimah.

In 1910 he joined the Imperial horse artillery as a so-called one-year volunteer. In January 1911 he broke his leg in a skiing accident. When the First World War broke out, he immediately volunteered for the artillery service and was sent to Galicia in January 1915. After being slightly wounded in August 1915, he was soon promoted to lieutenant but was taken prisoner, something his uneasy family didn’t learn about until after the armistice. “Martin’s captivity has sapped my moral. Do you know anyone in Genoa? He is being held at San Benigno inferiore,” Freud wrote to Ernest Jones on February 18, 1919.

He was released shortly thereafter, and Freud wrote to Pastor Pfister on October 5, “My son Martin, barely back from his captivity in Italy, has made himself a captive again through his engagement to the young lady of his choice, the daughter of a Viennese lawyer.” On December 7, 1919, he married Ernestine Drucker (Esti, 1896–1980), with whom he had two children, Anton Walter Freud, born April 3, 1921, and Myriam Sophie Loewenstein-Freud, born August 6, 1924.

Because of his background—he had a law degree and was working in a bank—he became increasingly involved in Freud’s investments and helped him to manage his books. When the retirement of Adolf Joseph Storfer in 1931 revealed the poor financial situation of the Internationaler Psychoanalytischer Verlag, Martin took control and with his father’s help appealed to the international community to obtain the necessary funds for its survival. But in 1936, after the Nazis had come to power in Germany, they sequestered the firm’s publications and shortly after the *Anschluss* did the same in Vienna, where Martin was troubled by the Gestapo.

Family affairs went badly, for Martin had several extramarital relations (including a very ambiguous relationship with an American patient of Freud,

Dr. Edith Jackson), which his wife didn’t discover until shortly before their departure from Austria on May 14, 1938.

His wife remained in France with their daughter, while Martin went on to London, shortly before his parents. His life there was not simple. From July to November 1940 he was interned as a “foreign enemy” in a camp near Liverpool, Huyton Camp, under terrible conditions. Freud, in his will, had made Ernst, Martin, and Anna the executors of his estate, but by 1946 an organization, which was run for many years by Ernst, was created to ensure the survival of his work and his memory in the field of psychoanalysis. Martin had many jobs and ended up running a smoke shop near the British Museum. In 1958 he published, against Anna’s advice, his book of memoirs, *Sigmund Freud: Man and Father*, which remains one of the primary sources for all biographers of Freud. He died on April 25, 1967, at the age of seventy-seven.

His wife Esti managed to escape France in 1940 with her daughter Sophie. They left Nice, where brother-in-law Olivier Freud lived, and traveled to Morocco, where they boarded a ship for the United States. She began a practice as a speech pathologist in the United States, where she lived until her death in 1980. She and Martin were never divorced.

ALAIN DE MIJOLLA

*See also:* Berggasse 19, Wien IX; First World War: The effect on the development of psychoanalysis; Freud-Bernays, Martha; Imago Publishing Company; Internationaler Psychoanalytischer Verlag; Lampl, Hans; Sigmund Freud Copyrights Limited.

### Bibliography

- Freud, Sigmund. (1985c). *The complete letters of Sigmund Freud to Wilhelm Fliess 1887–1904* (Jeffrey M. Masson, Ed. and Trans.). Cambridge, MA, London: Belknap Press of Harvard University Press.
- Freud, Martin. (1958). *Sigmund Freud: Man and father*. New York: J. Aronson.
- Gay, Peter. (1988) *Freud: A life for our time*. London-Melbourne: Dent.
- Jones, Ernest. (1959). *Free associations. Memories of a psycho-analyst*. London, New York: Basic Books.
- Roazen, Paul. (1993). *Meeting Freud’s family*. Amherst: University of Massachusetts Press.

## FREUD, JOSEF (1826–1897)

Josef Freud, ten years younger than his brother Jakob Freud, was born in 1826 in Tysmenitz, Galicia. We would have had no record of his existence if Freud hadn't referred to him in *The Interpretation of Dreams* (1900a, chap. 4) in the "dream of the uncle with the yellow beard." Freud was quite open in writing, "For I have only one uncle, my Uncle Josef. His story was a sad one. More than thirty years earlier his desire for gain had misled him into an act severely punishable by the law, and he was punished accordingly. My father, whose hair turned gray with grief in a few days, always used to say that Uncle Josef had never been a bad man, he had been a numbskull; that was the expression he used." For decades the complete story remained unknown, and Ernest Jones's biography even claimed that "he was only given a fine, for the Austrian police records show no sign of his imprisonment."

In reality, on June 20, 1865, Uncle Josef was arrested by the police as he was about to sell counterfeit rubles. He was involved in an international money trafficking ring that had contacts in Manchester, where his nephews Emanuel and Philipp Freud lived. Although suspected, they were never implicated in the crime. The news was published in the newspapers the following day, but Freud's name did not appear. However, during sentencing in February 1866, the Viennese press gave the story considerable coverage, announcing "ten years of forced labor for Freud." He was released after four years for good behavior, but little is known about what became of him after that, or about his wife Rebecca, whom he married in 1849 in Jassy (possibly this is the "Rebeka" who was elsewhere documented as brother Jakob's wife). Of their two children, only Deborah is mentioned by name; a friend of Adolfine Freud, she was a child at the time of his sentencing. He died at the Rudolf Hospital in Vienna on March 5, 1897 (Peter Swales, quoted in Grinstein, Alexander, 1990), at about the time that Freud had his dream.

Requested by Siegfried Bernfeld to inquire about Freud's youth, it was the wife of a Viennese professor, Mrs. Renée Gicklhorn, who unearthed the story, which came to light when Sigmund Freud was between nine and ten years old. It is easy to understand the affect this had on the Freud family. Josef, who had already been referred to as the "other—very

unfortunate—uncle from Vienna" in a letter Sigmund wrote to his fiancée in February 1886, twenty years after the affair, now reappeared—this *Verbrecher* (criminal), as he is known in one of the most frequently cited passages from *The Interpretation of Dreams*—as the symbol of the obstacle to his nephew's ambitions in 1897, the year Freud was so anxious to become a professor.

It should not come as a surprise that this dramatic episode from Freud's childhood has been extensively written about since its discovery. Freud's biographers have provided more or less accurate psychological analyses of the inventor of psychoanalysis, often in the hope of clarifying what they believe to be cracks in his theory.

ALAIN DE MIJOLLA

See also: *Interpretation of Dreams, The.*

### Bibliography

- Gicklhorn, Renée. (1976). *Sigmund Freud und der Onkeltraum. Dichtung und Wahrheit*. Horn/Ndösterr: F. Berger.
- Freud, Sigmund. (1900a). The interpretation of dreams. Part I. *SE*, 4: 1–338; The interpretation of dreams. Part II, *SE*, 5: 339–625.
- Grinstein, Alexander. (1990). *Freud at the Crossroads*. New York: International Universities Press.
- Krüll, Marianne. (1979). *Freud and his father*. (Arnold J. Pomerans, Trans.). New York: W. W. Norton.
- Mijolla, Alain de. (1979). "Mein Onkel Josef" à la une! *Études freudiennes*, 15–16, 183–192.
- Rand, Nicolas, and Torok, Maria. (1995). *Questions for Freud: The secret history of psychoanalysis*. Cambridge: Harvard University Press.

---

**FREUD, JULIUS.** See Freud, Sigmund (siblings)

---

**FREUD-KLEIN CONTROVERSIES, THE.** See Controversial Discussions

---

## FREUD: LIVING AND DYING

Dr. Max Schur was a psychoanalytically oriented internist who became Freud's physician in 1929. He treated Freud and members of his family until 1939, when Freud

died. Schur then emigrated to the United States. There many people tried to persuade him to write about Freud, but he was reluctant to do so out of respect for Freud's privacy. When the correspondence between Freud and Wilhelm Fliess was published in 1950, he was impressed by the historical and scientific value of his documents on Freud and agreed to make his notes available to Ernest Jones, who was preparing a biography of Freud. Disagreeing with some of Jones' assessments of Freud's physical and neurotic symptoms, Schur decided to craft a "biographical study" of Freud's life, concentrating on his changing attitudes toward life and death as revealed in his life, work, and correspondence.

Schur's book begins with a brief biographical review of Freud's early life, incorporating recently published material that threw light on some of Freud's reconstructions. Then, subjecting Freud's descriptions of his symptoms in his letters to Fliess in the early 1890s to a careful review, he disputes Jones's conclusion that Freud had a cardiac neurosis. Schur believed that the most likely diagnosis was a small coronary occlusion with typical anginal pains, arrhythmias, and mild cardiac insufficiency, aggravated by nicotine. As is well known, Freud was addicted to cigars, and he continued to find them necessary for creative concentration even when they were clearly contributing to his cancer during his last years. Schur believed that "neurotic anxiety was much less pronounced in Freud than excessive swings of mood, which at their low ebb had a definite depressive quality." He also described Freud's obsessive preoccupation with death and with dying at a certain age. During the cardiac episode Freud's relationship with Schur, which began in mutual admiration, intensified and took on characteristics of a "transference-like" relationship.

Schur examines Freud's self-analysis in the light of such transference. His discussion of Freud's "Irma dream" demonstrates that the dream was also an unrecognized attempt to exonerate Fliess in order to preserve Freud's idealization of Fliess. Schur also demonstrates how Freud's self-analysis led to a breakup of his friendship with Fliess in 1904 and how ghosts of the relationship continued to haunt Freud in the form of a preoccupation with death dates based on Fliess's numerical periods. Schur also pursues the broader theme of Freud's attitudes toward death throughout Freud's works, most notably when he discusses Freud's notion of the death instinct.

The last third of Schur's book is a painfully moving description of Freud's cancer, the surgical procedures

he endured, the tormenting prostheses he had to suffer, and the fortitude and remarkable capacity he demonstrated to continue to analyze and write despite everything. When Freud interviewed Schur before appointing Schur as his physician, he asked for two promises: that he would be told the truth and nothing but the truth, and that he would not be required to suffer unnecessarily. Schur ends with a description of how he fulfilled the second of these promises.

ROY K. LILLESKOV

*See also:* Death and psychoanalysis.

### Source Citation

Schur, Max. (1972). *Freud: Living and dying*. New York: International Universities Press.

### Bibliography

- Bowlby, John. (1960). Grief and mourning in infancy and early childhood. *Psychoanalytic Study of the Child*, 15, 9–52.
- Freud, Anna. (1946). *The ego and the mechanisms of defence*. New York: International Universities Press.
- Freud, Sigmund. (1926). Inhibitions, symptoms and anxiety. *SE*, 20: 77–174.
- Hartmann, Heinz. (1958). *Ego psychology and the problem of adaptation*. New York: International Universities Press.
- Jones, Ernest. (1953–1957). *Life and work of Sigmund Freud*. New York: Basic Books.
- Kanzer, Mark (Ed.). (1971). *The unconscious today*. New York: International Universities Press.
- Loewenstein, Rudolf, et al. (Eds.). (1966). *Psychoanalysis: a general psychology*. New York: International Universities Press.
- Schur, Max. (1953). The ego in anxiety. In Rudolf Loewenstein (Ed.), *Drives, affects, and behavior* (pp. 67–103). New York: International Universities Press.
- . (1969). The background of Freud's disturbance on the acropolis. *American Imago*, 26, 303–323.
- Schur, Max, and Ritvo, Lucille B. (1970). The concept of development and evolution in psychoanalysis. In Lester R. Aronson et al. (Eds.), *Development and evolution of behavior*. San Francisco: W. H. Freeman.

---

## FREUD MUSEUM

The Freud Museum, at 20 Maresfield Gardens in London, was Sigmund Freud's "last address on this

planet,” as he wrote to Jeanne Lampl-de Groot on August 22, 1938. He and his family moved in on September 27, 1938, and he died there on September 23, 1939.

After his death his family remained in the house: the last occupant was his youngest daughter Anna, who died in 1982. As stipulated in her will, the house was turned into a museum under the auspices of the Sigmund Freud Archives and the New-Land Foundation, a charitable fund run by the family of her friend, the American psychoanalyst Muriel Gardiner. The Museum was opened to the public in 1986.

Its centerpiece is Sigmund Freud’s working environment, preserved as it was during his lifetime. The study contains his personal library, his collection of antiquities, and the original couch that witnessed the discovery of psychoanalysis. When the Freud family fled from Nazi Austria in June 1938, they arrived virtually empty handed, but all their possessions were sent on afterwards. Consequently, the Museum contains all their furniture, carpets, pictures, and other belongings, in addition to Freud’s books and antiquities. Most of his papers were subsequently removed to the Sigmund Freud Archive at the U.S. Library of Congress. However, copies of many of these documents remained in the museum, and this copy archive forms a valuable resource for European scholars. The archive also includes many of Anna Freud’s papers and related documents. In addition, the Freud family photo albums form the center of an extensive photo archive.

The museum attracts fourteen thousand visitors each year from all over the world. In little over a decade of existence it has also established itself as a workplace and study center, as well as a vibrant memorial to Freud’s life and work. It hosts regular national and international conferences on cultural and psychoanalytical themes, as well as lectures and study seminars, and its education program reaches out to students and schoolchildren in the local community.

MICHAEL MOLNAR

*See also:* Sigmund Freud Archives.

### **Bibliography**

- Appignanesi, Lisa, and Forrester, John. (1992). *Freud’s women*. London: Weidenfeld and Nicolson.
- Bernfeld-Cassirer, Suzanne. (1951). Freud and archaeology. *American Imago*, 8, 107–128.

Davies, J. Keith, and Botting, Wendy. (1989). La bibliothèque de Freud. In Eric Gubel (Ed.), *Le sphinx de Vienne, Sigmund Freud: l’art et l’archéologie* (pp. 199–201). Gent, Belgium: Ludion.

Gamwell, Lynn, and Wells, Richard (Eds.). (1989). *Sigmund Freud and art: His personal collection of antiquities*. London: Freud Museum.

---

## **FREUD-NATHANSON, AMALIA MALKA (1835–1930)**

Sigmund Freud’s mother, Amalia Malka Freud-Nathanson, was born, according to family tradition, on August 18, 1835, in Brody, in Galicia, and died in Vienna on September 12, 1930.

The daughter of Jacob Nathanson and Sara Widens, Amalia had three older brothers and one younger brother, Julius. The Jewish calendar makes Amalia’s date of birth somewhat uncertain, as Freud once told Wilhelm Fliess, but it was celebrated the same day as the birth of Emperor of Austria, Franz Josef, and the annual national holiday made it the occasion of humorous family banter.

The Nathansons had lived in Galicia before moving to Odessa, then to Vienna, where Amalia, at age twenty, met Jakob Freud. Jakob shared her father’s first name and was twenty years older than she; they were married in a synagogue in 1855. She went to live with him in Freiberg, in Moravia, where on May 6, 1856, she gave birth to her son Sigmund.

Other children soon followed: Julius in October 1857 (the namesake of Amalia’s younger brother, who was tubercular, both to die within a year); Anna on December 31, 1858; Regine Debora (Rosa) on March 21, 1860; Maria (Mitzi) on March 22, 1861; Esther Adolfine (Dolfi) on July 23, 1862; Pauline Regine (Pauli) on May 3, 1864; and Alexander Gotthold Efraim on April 15 (or 19), 1866.

Diagnosed with tuberculosis, Amalia took frequent cures at Roznau, twenty-five kilometers from Freiberg, even after moving to Vienna in the wake of Jakob’s failed financial ventures. In August 1859 she and her two children left Freiberg on a railway journey that Freud would recall among his earliest memories during his self-analysis: At the railroad station in Breslau gas jets made him think of the “flames of hell” and he also recalled seeing his mother nude (“*matrem nudam*” [Anzieu, Didier, 1986, p. 14]).



In other of Freud's memories he recalled his mother as "slim and beautiful" (Gay, 1988, p. 7), and as teaching him to read and write German. Once, while at work in the kitchen, she responded to his questioning the idea that people are made of dust and therefore mortal by rubbing her hands to elicit the blackish bits of epidermis. When Freud was about ten years old, he had an anxiety dream in which he saw his "beloved mother with a peculiarly calm, sleeping facial expression, being carried into the room by two (or three) persons with bird's beaks . . ." (p. 504).

Amalia appears to have been an anxious mother, if one considers as exemplary the precautions that Freud took to conceal from her his adolescent plans to travel to London, or her response to the 1873 cholera epidemic that raged in Vienna while she was staying in Roznau. But she was also a supportive mother who foresaw a great destiny for Sigmund, a gifted child to whom she granted many favors, triggering jealousy among her other children. Freud would help his mother financially as soon as he began to earn a living and, together with his brother, Alexander, he would continue to support her to the end of her life.

Coquettish as a young woman, she enjoyed card parties, but Amalia became difficult as she grew older. According to her grandson Martin Freud, she was a typical Galician Jewish woman; she "had great vitality and much impatience; she had a hunger for life and an indomitable spirit" (1958, p. 11).

After she became a widow, Amalia lived with her daughter Adolfine (Dolfi), and made yearly trips to Ischl for her lung ailment. In her home on Grüne Thorgasse, by family custom, she would receive her "goldener Sigi" and other children and grandchildren every Sunday.

Freud hid from Amalia the deaths of his daughter Sophie and her child, Heinele, and he cautiously told her about surgery on his jaw without mentioning cancer. Indeed, her old age and death presented Freud with a problem he discussed with Karl Abraham as early as May 1918: "My Mother will be eighty-three this year and is no longer very strong. I sometimes think I shall feel a little freer when she dies, for the idea that she might be told that I have died is a terrifying thought." (Jones, Ernest, 1955, Vol. 2, p. 196) He brought up the problem again after the death of Max Eitingon's mother on December 1, 1929, repeating almost word for word what he had written to Ludwig

Binswanger the previous January: "The loss of a mother must be something very strange, unlike anything else, and must arouse emotions that are hard to grasp. I myself still have a mother, and she bars my way to the longed-for rest, to eternal nothingness; I somehow could not forgive myself if I were to die before her." (Freud, 1960, p. 392)

Three days after her death on September 12, 1930, Freud wrote to Ernest Jones: "I will not disguise the fact that my reaction to this event because of special circumstances been a curious one. Assuredly, there is no saying, what effects such an experience may produce in deeper layers, but on the surface I can detect only two things: an increase in personal freedom, since it was always a terrifying thought that she might come to hear of my death; and secondly, the satisfaction that at last she has achieved the deliverance for which she had earned a right after such a long life. No grief otherwise, such as my ten years younger brother is painfully experiencing. I was not at the funeral; again Anna represented me as at Frankfort. Her value to me can hardly be heightened." (Jones, p. 152)

For all intents and purposes, Freud's relationship with his mother may be said to have been excellent and his comment concerning Goethe is usually cited: "[I]f a man has been his mother's undisputed darling he retains throughout his life the triumphant feeling, the confidence in success, which not seldom brings actual success along with it." (Freud 1917b, p. 156)

ALAIN DE MIJOLLA

*See also:* Freud, Jakob Kollomon (or Kelemen or Kallamon); Freud, Sigmund (siblings); Judaism and psychoanalysis.

### **Bibliography**

- Anzieu, Didier. (1986). *Freud's self-analysis*. Madison, CT: International Universities Press.
- Gay, Peter. (1988). *Freud: A life for our time*. New York: Doubleday.
- Jones, Ernest. (1953–57). *Life and work of Sigmund Freud*. New York: Basic Books.
- Freud, Martin. (1958). *Sigmund Freud: Man and father*. New York: Vanguard Press.
- Freud, Sigmund. (1917b). A childhood recollection from "Dichtung und Wahrheit." *SE*, 17: 145–156.

———. (1960a). *Letters of Sigmund Freud*. New York: McGraw-Hill.

## FREUD, OLIVER (1891–1969)

Oliver Freud, named after Oliver Cromwell, was the third son of Sigmund and Martha Freud. Born in Vienna on February 19, 1891, he died in Williamstown, Massachusetts, in February 1969. His mother's favorite, Oliver's life was less tied to that of his parents than his other brothers and sisters, in spite of the compliments paid to him by Freud for his precocious interests in mountains and railways and his gift for construction.

After completing his "matura" (equivalent to the first year of college), in 1909 he entered the Vienna Polytechnic, a private school. He graduated with a degree in civil engineering in 1915. He was not enlisted when the First World War broke out but was put to work building a barracks, then a tunnel, until December 1916. After this he was inducted as an officer in an engineering regiment.

Married in December 1915, he was divorced by September 1916. Sent to Galicia in 1916, then Hungary, he returned at the end of hostilities and was discharged on December 2, 1918. In July 1919 Freud remarked that Oliver was the only one of his three sons who found work after his return. He lived in Berlin, like Ernst, and both brothers traveled to Hamburg for the funeral of their sister Sophie in January 1920.

But the boy was a problem for Freud. He confided in Max Eitingon on October 30, 1920, that he was often worried about this son, who "had been his pride and secret hope," and suggested that Oliver "would need to be analyzed" because of the symptoms of obsessional neurosis. In 1921 Oliver, upon the advice of Hans Lampl, a fellow student and friend of Martin, began analysis with Franz Alexander (Roazen, 1993).

After a stay in Romania, he married Henny Fuchs (born February 11, 1892, in Berlin, died 1971 in North America) in Berlin on April 10, 1923. His mother, Martin, and Anna, after returning from Göttingen to visit Lou Andreas-Salomé, were present for the marriage. On September 3, 1924, their daughter Eva Mathilde Freud was born. Freud warmly greeted the family on Christmas 1924, not wishing to "delay any further making the acquaintance of the adorable new grandchild."

While living in Berlin, Oliver went without work from 1932 until April 7, 1933. Freud wrote to Ernest Jones, "My unemployed son Oliver, whom I have been supporting for a year, is coming to Vienna tomorrow to discuss his future. There is little doubt that he will never find work in Berlin again (he is a civil engineer)."

Oliver emigrated to France that same year, 1933. He first lived in Brittany, near Dinard, then in Paris, where Freud sent a letter of introduction to Arnold Zweig on October 25, 1933, "But I have a son in Paris—Oliver, who with his wife and child lives in 16me, rue George Sand. He is a civil engineer, a very talented man [*ein hochbegabter Alleswisser*], knows everything, excellent at his job; nice wife and charming little daughter. I'm afraid he will not achieve anything in Paris. I'd be very pleased if you could meet him."

In 1934 he went to Nice, where he began working as a photographer, about which Freud remarked, "At least he has found a job that satisfies his passion for tinkering" (letter to Zweig, June 13, 1935). Oliver remained in Nice, aside from a visit to Vienna in November 1936, until 1943.

After obtaining a visa for America in 1942, Oliver, Henry, and Eva tried to leave France through Spain, but fear of deportation led them back to Nice, now under Italian occupation. René Laforgue, whose property of Garéoult was nearby, is said to have helped them obtain forged papers and leave France for the United States in 1943.

But their daughter Eva, who was nineteen years old at the time, refused to go with them and remained with her fiancé on the Mediterranean coast. She was later analyzed by René Laforgue and then by Henri Stern. She died tragically from septicemia contracted after an abortion, complicated by a cerebral abscess, in the Hospital of La Timone in Marseille, on November 4, 1944.

Her parents reached Philadelphia, where Oliver found work as an engineer with the Budd Company. He and Henny retired in Williamstown, in western Massachusetts, where he died in February 1969.

Arnold Zweig wrote to Freud from Haifa on January 21, 1934, "And since I've been here I have been thinking very much about this son of yours, who is also too decent to find it easy to adapt himself to life. It was shattering to observe how he talked most vividly

and warmly when speaking about his wartime service. Just like all other men of his generation and of his circumstances who now find that they have to begin all over again at a time when they are firmly set in their ways of thought and feeling, habits and ambitions. No one can take it amiss if these men do not wish to have anything to do with the contemporary business scene and prefer to take refuge in memories of a time when a man (especially a young man) merely needed to risk his life to be fulfilling all the demands that society made upon him.”

ALAIN DE MIJOLLA

*See also:* Berggasse 19, Wien IX; Freud-Bernays, Martha.

### **Bibliography**

- Gay, Peter. (1988). *Freud: A life for our time*. London-Melbourne: Dent.
- Jones, Ernest. (1959). *Free associations. Memories of a psycho-analyst*. London, New York; Basic Books.
- Roazen, Paul. (1993). *Meeting Freud's family*. Amherst: University of Massachusetts Press.
- Second, Pierre. (1993). Eva Freud, une vie: Berlin 1924, Nice 1934, Marseille 1944. *Trames*, 75, 16.

---

**FREUD, PHILIPP.** *See* Freud, Sigmund (siblings)

---

### **FREUD, SIGMUND (SIBLINGS)**

Sigmund Freud, born May 6, 1856, was Jakob Freud's third child. From a previous marriage, in 1832 to Sally Kanner, he had two sons, Emanuel and Philipp. After Sally died in 1852, a brief second marriage to a woman named Rebekka also ended with her death. Jakob's third marriage, to Amalie Nathanson on July 29, 1855, produced eight more children. In addition to Sigmund (Sigmund), the firstborn, were born Julius, Anna, Rosa, Marie, Adolfine, Pauline, and Alexander.

#### **Freud, Emanuel**

Born in 1833 in Tysmenitz in Galicia, then part of the Austro-Hungarian Empire, Emanuel Freud worked in his father's textile business. In 1852, he married (Kokach), who was born in Milow in Russia in 1834 (perhaps 1836). In Freiberg he settled a few blocks from his father's home at 42, place du Marché. His

children's nurse, Monika Zajicova, was said to also have been Sigmund's "Nannie."

Freud's oldest nephew, Johann, was born in Freiberg on August 13, 1855. I have also long known," wrote Freud to Fliess in 1897, "the companion of my misdeeds between the ages of one and two years; it is my nephew, a year older than myself, who is now living in Manchester and who visited us in Vienna when I was fourteen years old. The two of us seem occasionally to have behaved cruelly to my niece, who was a year younger" (Freud, 1985c, p. 268) "Until the end of my third year we had been inseparable; we had loved each other and fought each other, and, as I have already hinted, this childish relation had determined all my later feelings in my intercourse with persons of my own age" (1900a, p. 424). Freud also wrote, "An intimate friend and a hated enemy have always been indispensable to my emotional life; I have always been able to create them anew, and not infrequently my childish ideal has been so closely approached that friend and enemy have coincided in the same person; but not simultaneously, of course, as was the case in my early childhood" (1900a, p. 483). Johann's whereabouts cannot be traced after 1919, and what happened to him in later years is unknown.

On November 20, 1856, Pauline Freud, Sigmund's niece, was born in Freiberg; she would die a spinster in Manchester in 1944. The games she played with John and Sigmund in the meadow covered in yellow flowers, which Freud recalled in "Screen Memories" (1899a), are thought to have taken place during the summer of 1859. Freud's unconscious fantasy of Pauline's defloration by John and himself led some to believe that both boys sexually assaulted the little girl (Krüll, 1979). Towards 1875, it seems that Jakob Freud had the idea of sending Sigmund to England with his brothers and having him marry Pauline.

On February 22, 1859, Bertha Freud was born in Freiberg. She died accidentally from a fall on a staircase in 1944.

Toward 1859–1860, while Jakob and his family left Freiberg for Vienna, Emanuel emigrated with relatives and his brother Philipp to Manchester, England. Solomon Samuel (Sam) Freud, Emanuel's fourth son, was born there on June 28, 1860. His correspondence with Sigmund Freud was eventually published (Freud 1996 [1911–38]). He died in 1945.

On May 12, 1862, Matilda Freud was born in Manchester.

In 1900 Freud described Emanuel to Wilhelm Fliess (Freud 1985c, p. 417) on the occasion of his half-brother's trip to Vienna with his son Sam: "He brought with him a real air of refreshment because he is a marvelous man, vigorous and mentally indefatigable despite his sixty-eight or sixty-nine years, who has always meant a great deal to me."

Freud paid visits to Emanuel in August 1875 and to his sister Rosa in 1884–1885. He went to England for a second two-week visit to his brothers in September 1908.

Emmanuel died from a fall from a train traveling between Manchester and Southport on October 17, 1914, just six days before the anniversary of Jacob's death—a coincidence noted by Freud.

Marie, Emanuel's wife, died in Manchester in 1923.

### **Freud, Philipp**

Philipp Freud was born in Tysmenitz around 1835. He would play an interesting role in his brother's life that Freud would only reconstruct in October 1897 during his self-analysis. It was Philipp who "locked up Nannie in prison" for stealing shortly before the family's departure from Freiberg. He was living across the street from Freud's parents and was the same age as Freud's mother, Amalie. Some authors have imagined from Freud's fantasy that Philipp and Amalie were together as a "couple" with the suggestion that he had an affair with her (Krüll, 1979). He contributed in any event to the confusion of generations in Freud's mind that was only clarified in 1875 during his visit to England.

Philipp married at about forty years old, in Manchester on January 15, 1873, to Matilda Bloomer (Bloomah), from Birmingham (1839–1925). They had two children. Pauline Mary (Poppy) was born on October 23, 1873, married Frederick Oswald Hartwig and died in Bucklow/Chester on June 23, 1951. Morris Herbert Walter was born on April 2, 1876, and died in Port Elizabeth, South Africa, on November 28, 1938.

Philipp died in Manchester on August 29, 1911.

Freud (1989a, pp. 126–127) described this part of his family in an 1875 letter to Eduard Silberstein: "You will, no doubt, wish to know about my relatives in

England and about my attitude toward them. I don't think I've ever told you much about them. There two brothers on my father's side, from my father's first marriage, twenty-two years older than I, the older, Emanuel, having married in early youth, the younger, Philipp, two and a half years ago. They used to live with us in Freiberg, where the elder brother's three oldest children were born! The unfavorable turn their business took there caused them to move to England, which they have not left since 1859. I can say that they now hold a generally respected position, not because of their wealth, for they are not rich, but because of their personal character. They are shopkeepers, i.e., merchants who have a shop, the elder selling cloth and the younger jewelry, in the sense that word seems to have in England. My two sisters-in-law are good and jolly women, one of them an English woman, which made my conversations with her extremely agreeable. Of those persons in our family whose uncle I may call myself, you are already acquainted with John, he is an Englishman in every respect, with a knowledge of languages and technical matters well beyond the usual business education. Unknown to you, and until recently, to me, are two charming nieces, Pauline, who is nineteen, and Bertha, who is seventeen, and a fifteen-year-old boy by the name of Samuel—which I believe has been fashionable in England ever since Pickwick—and who is generally considered to be a 'sharp and deep' young fellow" (pp. 126–7).

Sigmund Freud was born on May 6, 1856, the first of Jacob and Amalie Freud's eight children.

### **Freud, Julius**

Julius Freud was born in October 1857 in Freiberg, when Sigmund was eighteen months old. He died the next April, the same year that Amalie's brother, Julius's namesake, also died.

On October 3, 1897, Freud (1985e, p. 268) wrote to Wilhelm Fliess about one of the discoveries of his self-analysis: "that I greeted my one-year-younger brother (who died after a few months) with adverse wishes and genuine childhood jealousy; and that his death left the germ of [self-] reproaches in me."

### **Bernays-Freud, Anna**

Anna Bernays-Freud was born on December 31, 1858, in Freiberg and died on March 11, 1955, in New York. Her relationship with her older brother was often difficult, but she was her father's favorite daughter. In her

memoirs (Bernays-Freud, 1940), she recalled Sigmund's special privileges, the fact that he enjoyed his own room, and that it was forbidden to play the piano in order not to disturb him; he also censored what she read.

Anna married Martha's oldest brother, Eli Bernays (1860-1923) on October 14, 1883, with whom Freud, who didn't attend their wedding, felt for a time resentful regarding his sister's dowry.

Anna and Eli emigrated in the United States in 1892 with their two children, Lucy, born in 1886, and Judith born a year earlier. In 1973 the latter, Judith Bernays-Heller, published a brief memoir of her visits to grandparents Jacob and Amalie (Bernays-Heller, 1973). Anna and Eli had three more children: Edward Louis was born in 1891, and Hella and Martha in 1893 and 1894, respectively.

Eli, who enjoyed a brilliant career in business, was in charge of Freud's works in the United States and he had some disagreements with Ernest Jones concerning their English translations. After Eli's death, in 1925 Freud wrote to his son Edward in reply to the latter's proposition: "What deprives all autobiographies of value is their tissue of lies. Let's just say parenthetically that your publisher shows American naivete in imagining that a man, honest until now, could stoop to so low for five thousand dollars. The temptation would begin at one hundred times that sum, but even then I would renounce it after half an hour." On March 8, 1920, he wrote to Ernest Jones, describing Edward as "an honest boy when I knew him. I know not how far he has become Americanized" (Gay 1989, p. 568) and in September he announced, to Jones's chagrin, that his nephew would serve as literary executive for American rights to his works.

### **Graf-Freud, Regina Deborah (Rosa)**

Regina Deborah Graf-Freud (Rosa) was born on March 21, 1860, and died in the Treblinka concentration camp in 1942. Considered his favorite sister, Freud in 1886 acknowledged that the beautiful Rosa, like himself, had "a nicely developed tendency toward neurasthenia" (Freud 1960, p. 210). On October 22, 1874, Freud wrote to Eduard Silberstein: "Rosa has entered a school of drawing and design newly established for the perfection of feminine handicrafts. I have taken charge of the rest of her education and am sacrificing one of my lectures to that end. The gods cannot possibly have rejoiced at this sacrifice as much as I did" (Freud 1989a, p. 67). She would return the

favor in various ways, by taking care of his laundry, for example, during his stay in Paris, later by caring for his children during vacations.

Rosa's fate was particularly unfortunate. After a disappointing love affair, she married Heinrich Graf (b. 1852), a physician, on May 17, 1896, but he died in 1908 at the age of fifty-six. Her son, Hermann Adolf, was born on July 13, 1897 and died in action during World War I, in early 1917. Finally, her daughter, Cäcilie, born October 18, 1899, and nicknamed Mause, whom Freud called "my favorite niece," a dear girl of 23, was unmarried and pregnant when she committed suicide with an overdose of the barbiturate veronal on August 18, 1922.

The last document from Rosa is a letter transmitted by the International Red Cross to Freud's address in London. Twenty five words only were authorized: "Geliebte Martha! Tief bewegt grüssen Dich Alle. Erbitten Deiner Alexanders Familie Befinden. Vier einsam. Traurig. Leidlich. Gesund. —S. freundschaftlich. Ganze Einrichtung bestens engleagert. Graf Rosa" ("Dear Martha! Greetings with heartfelt emotion. Wondering about the state of your Alexander's family. Four alone. Sad. Painful. Health. Yours warmly. Best furnishings in storage. Graf Rosa.")

Rosa was deported in Theresienstadt on August 28, 1942, at the same time as her three sisters, with whom she was living in a increasingly cramped apartment. According to a witness, during the Nuremberg trial, in October 1942 in the Treblinka concentration camp, the commandant of the camp to whom she introduced herself as Sigmund Freud's sister, examined her identification and "said that there was probably some mistake and showed her the railroad signs, telling her that there would be a train to take her back to Vienna in two hours. She could leave her belongings, go into the showers and, after bathing, her documents and her ticket to Vienna would be ready. Rose naturally went into the showers and never returned" (Leupold-Löwenthal, 1989).

### **Moritz-Freud Maria (Mitzi)**

Maria Moritz-Freud (Mitzi) was born on March 22, 1861, and died in the Maly Trostinec, the extermination camp, in 1942. In 1885 she had to work as a governess, which led Freud, then in Paris, while observing nannies with young children, to write Martha: "I couldn't help thinking of poor Mitzi and grew very, very furious and full of revolutionary thoughts" (Freud 1960, p. 173).

In 1887 Mitzi married her Romanian cousin Moritz Freud (1857–1920). They had four children, Margarethe, born in 1887; Lilly Marlé-Freud, born in 1888, who became a well-known actress; Martha Gertrude, born in 1892, who illustrated children books under the name “Tom” and would commit suicide in 1930, a year after her husband the journalist Jakob Seidmann, killed himself; Theodor (Teddy) and born in 1904, whose twin was stillborn and who died from drowning in 1923 in Berlin. Martha’s daughter, Angela Seidmann, was in the care of Freud and Anna for a while before emigrating to Haifa.

Mitzi, reunited with her sisters in Vienna after her husband’s death, shared their fate in the Holocaust. She was deported to the concentration camp of Theresienstadt, on June 29, 1942, then to Maly Trostinec where she disappeared (Leupold-Löwenthal, 1989).

#### **Freud, Esther Adolfine (Dolfi)**

Esther Adolfine (Dolfi) was born on July 23, 1862, and died in 1943 in the concentration camp at Treblinka. She was unmarried and cared for her father Jakob when he fell ill, then of her mother, becoming impetuous Amalie’s constant companion, which her nephew Martin considered could not have been a welcome fate. “She was not clever or in any way remarkable, and it might be true to say that constant attendance on Amalie had suppressed her personality into a condition of dependence from which she never recovered” (M. Freud, 1958, p. 16).

Dolfi was deported with Mitzi and Paula to the concentration camp of Theresienstadt on August 28, 1942, where she died from “internal hemorrhages” on February 5, 1943, according to information gathered by Harry Freud after the war, perhaps due to malnutrition. (Leupold-Löwenthal, 1989).

#### **Winternitz-Freud, Pauline Regine (Pauli)**

Pauline Regine Winternitz-Freud (Pauli) was born on May 3, 1864, and died in the Holocaust in 1942. She was married to Valentin Winternitz and emigrated to the United States, where their daughter, Rose Beatrice (Rosi), was born on March 18, 1896. After her husband’s death in 1900, on Freud’s advice, she returned to Berlin, where she lived with her husband’s family before joining relatives in Vienna. Deported from that city in June 1942, she was taken first to the concentration camp of Theresienstadt, then to the exter-

mination camp or Maly Trostinec (Leupold-Löwenthal, 1989).

In 1913, Rosi, just seventeen years old, developed psychological problems that suggested psychosis. Ten years later and pregnant, she married Ernst Waldinger, a young poet, but the couple was not happy and, in 1931, she had a relapse. Rosi successfully emigrated to the United States and in 1946 entered analysis with Paul Federn in New York, probably with the financial assistance of Anna Freud.

#### **Freud, Alexander Gotthold Efraim**

Alexander Gotthold Efraim Freud was born on April 15 (or April 19), 1866, in Vienna, and died in 1943 in Canada. The youngest of the family, his name was chosen by Freud himself at a family meeting.

For a number of years Alexander was closest to his older brother, sharing with him, until Freud married, Easter and summer vacations, mainly in Italy after a first visit there in 1895. He took part in the 1897 trip during which Freud contemplated Luca Signorelli’s frescoes, and in the visit to Rome at the end of August 1901. “It was a high point of my life” as wrote Freud to Wilhelm Fliess. He was also with his brother on the Acropolis, during the sudden “disturbance of memory” in Athens in September 1904.

Merry and whimsical and a music-lover, Alexander “was an excellent story-teller who could imitate the various accents of the characters in his stories, as his nephew would write (M. Freud, 1958, p. 17). He did not pursue an education but, intelligent and hardworking, became a specialist in transportation and worked at the Vienna Chamber of Commerce. On August 20, 1899, Freud wrote to Fliess: “Alexander was here for four days; he will lecture on tariff rates at the Export Academy and will be given the title and rank of professor extraordinarius after one year—much earlier in fact than I” (Freud, 1985c). With his expertise, he was responsible for organizing Freud’s voyage to America in 1909.

Also in 1909, Alexander married Sophie Sabine Schreiber in a synagogue, in a double ceremony with his niece Mathilde. His wife gave birth on December 21, 1909, to Harry, their only child. With an excellent livelihood, he shared with Freud the support of their mother and Dolfi. He was, according to his brother, much more upset than he by Amalie’s death in 1930. In 1936 he commissioned Wilhelm Victor Krauss to paint Freud’s portrait.

In March 1938, shortly after the Alexander emigrated to Switzerland. Sigmund, at the time still in Vienna wrote Ernest Jones (April 28, 1938) that his brother caused him considerable worry; he had reacted badly to the loss of his business and was in poor health. By shared decision, the brothers left a large sum (160,000 Austrian Schillings) to their four sisters that would have been sufficient for a comfortable living in Vienna; they saw no serious danger to their remaining in Vienna. Freud soon realized his mistake and at his request Marie Bonaparte attempted to secure their passage from Austria, but without success.

Alexander gave up his Anglophobia and pro-German sentiments that dated to the First World War to emigrate to London in September 1938, where he also joined his son Harry. It was this latest who wrote to his aunts a letter they never receive and in which he described Sigmund's last days.

Alexander and his wife would emigrate to Canada, where he died in 1943.

*See also:* Freud, Jacob Kolloman (or Kelemen or Kallamon); Freud-Nathanson, Amalie Malka.

### **Bibliography**

- Bernays-Freud, Anna. (November 1940). My brother Sigmund Freud. *American Mercury* 51 (203), 335–342.
- Bernays-Heller, Judith. (1973). Freud's mother and father. In *Freud as we knew him*. (H.M. Ruitenbeck, Ed.). Detroit: Wayne State University Press.
- Freud, Martin. (1958). *Sigmund Freud: Man and father*. New York: Vanguard Press.
- Freud, Sigmund. (1900a). *The Interpretation of Dreams*. SE 4–5.
- . (1960). *Letters*. New York: Basic Books.
- . (1989). *Letters of Sigmund Freud and Eduard Silberstein: 1871–1881*. Cambridge, MA: Harvard University Press.
- Krüll, Marianne. (1979). *Freud und sein Vater. Die Entstehung der Psychoanalyse und Freuds ungelöste Vaterbindung*. Beck.
- . (1986). *Freud and His Father*. (Arnold J. Pomerans, Trans.). New York: W.W. Norton. (Original work published 1979).
- Leupold-Löwenthal. (1989). Die Vertreibung der Familie Freud 1938. *Psyche-Zeitschrift für Psychoanalyse und ihre Anwendungen*, 43 (10), 908–928.

## **FREUD, SIGMUND SCHLOMO (1856–1939)**

Sigmund Schlomo Freud was born on May 6, 1856, in Freiberg (now Priborg), Moravia (now the Slovak Republic), and died on September 23, 1939, in London. He was the son of Amalia Nathanson and of Jakob Freud, a draper, who had two children (Emanuel and Philipp) from a previous marriage. Freud was the first child of a couple in which the husband was forty years old, twice as old as his young wife. Over the next ten years, five daughters and two more sons would be born.

He was circumcised a week after birth. When he was two years old, a younger brother, Julius, died at the age of seven months, the first of several traumas of his early childhood. Others included the arrest for theft of “Nanie” his nurse; the departure of his father for Austria after a series of bad business dealings; the emigration to Great Britain of his older half-brothers and their children, his first playmates; and, most crucially, his own exile at the age of three. He rejoined his father in Vienna in the company of his mother after a lengthy train trip that left a deep impression on him.

He remembered his constant poverty following his arrival in the Austrian capital in 1859 and during his childhood, but alluded only once to the family's shame after his uncle Josef was condemned to ten years of forced labor for trafficking in counterfeit currency in 1866. He was a brilliant student, however, and after completing his “matura” (equivalent of the first year of college), was able to choose between law and natural science. He enrolled in medical school and after briefly studying philosophy (Franz Brentano was one of his teachers), decided to major in zoology.

In the summer of 1875, after a brief stay in Great Britain with his half-brothers in Manchester, he was able to put together a better idea of his place in the family genealogy. The following year he obtained a research grant to work at the Experimental Zoology Station of the University of Vienna in Trieste, where his work helped demonstrate the existence of testicles in the male eel. His work was presented to the Academy of Sciences in March 1877 and published in April (1877b), signaling his entry, at the age of twenty-one, into the world of science. In the following years his research and personal interest led him to study the anatomy of the nervous system; he hoped that through his research he would be able to achieve what he had

always dreamed of—financial security. But in spite of his success, his material life remained precarious.

In October 1876 he entered Professor Ernst Brücke's Physiologisches Institut, where he remained until 1882. He became friends with the two assistants, Ernst von Fleischl and Josef Breuer, and investigated the posterior nerve roots of the Petromyzon, or sea lamprey. Impressed by Ernst Brücke's personality, he became an adept of the positivist school of Emil Du Bois-Reymond, who claimed that biology could be explained by physico-chemical forces whose effects are strictly deterministic. In March 1881, Freud was made doctor of medicine, while continuing his research and writing on subjects as distant from human clinical practice as the nerve cells of crayfish.

But his future as a laboratory researcher was called into question when he met Martha Bernays, who became his wife four years later. He needed to provide an income for his future household, and followed the advice Brücke had given him in June—to abandon pure research and go into medical practice. This prospect failed to excite Freud, as he wrote many years later, "After forty one years of medical activity, my self-knowledge tells me that I have never really been a doctor in the proper sense. I became a doctor through being compelled to deviate from my original purpose; and the triumph of my life lies in my having, after a long and roundabout journey, found my way back to my earliest path. I have no knowledge of having had any craving in my early childhood to help suffering humanity. My innate sadistic disposition was not a very strong one, so that I had no need to develop this one of its derivatives. Nor did I ever play the 'doctor game'; my infantile curiosity evidently chose other paths. In my youth I felt an overpowering need to understand something of the riddles of the world in which we live and perhaps even to contribute something to their solution" (1927a).

Freud worked in various departments of the Vienna General Hospital to complete his training. While continuing his research on cerebral anatomy and pathology, he became interested in psychiatry (while working with Professor Theodor Meynert) and the nascent field of neurology. This very likely contributed to Freud's failure to reap the rewards of his research on cocaine, which he had begun in 1884. More preoccupied with its euphoric effects and what he incorrectly believed to be its ability to serve as a substitute for the opiates, he missed the opportunity to discover its local

ocular anesthetic properties. For several years he continued to ingest a certain amount of cocaine to overcome his timidity and increase his ability to work, which he discussed openly in his correspondence.

Appointed privat-docent in July 1885, he requested a grant to study neurology with Jean Martin Charcot in Paris. His internship at the Salpêtrière Hospital from October 13, 1885, to February 23, 1886 derailed his other projects, by exposing him to disturbances of mental origin. In terms of etiological research as well as his career as a specialist in neurology, the clinical lessons of the Parisian master, then at the height of his glory, demonstrated to Freud the importance of syndromes that had until then been characterized as "hysterical." Charcot's personality fascinated Freud and this first trip outside the Viennese family circle was to have a decisive effect on his future.

After returning to Vienna he set up a private practice on April 25, 1886, after a short stay in Berlin working with Professor Joseph Baginsky, where he familiarized himself with pediatrics. This enabled him, over a ten-year period, to maintain a steady practice in the department of neurology that the pediatrician Max Kassowitz (1842–1923) had opened at the Vienna Institute for Child Diseases. Once established he was finally able to get married, which he did on September 13, 1886. But his attempt to become Charcot's spokesman among Viennese neurologists and psychiatrists met with open rejection, especially from Theodor Meynert. Demanding, vulnerable, and passionate, for years he interpreted criticism or ignorance of his contributions as a form of systematic hostility that he often attributed to anti-Semitism, which was widespread in Vienna, especially in academic and medical circles.

His solitude was broken by a meeting that would later develop into a close friendship that lasted for nearly fifteen years. Wilhelm Fliess, an otorhinolaryngologist (ear-nose-and-throat specialist) in Berlin, gradually became a confidant who could share some of Freud's doubts and research activities, and a witness to the clinical experiments and theoretical hypotheses that littered the long road leading to the birth of psychoanalysis. An extensive correspondence and several meetings, referred to as "conferences," enabled them to exchange ideas about their research, which often fell upon deaf ears when Freud clearly overestimated his friend's comprehension. They also exchanged personal information. For Freud it was the anxiety about



money and the birth of six children in succession, something Fliess's theories on menstruation and the hope that they brought of a possible method of contraception failed to resolve.

Their friendship gradually took the place of an earlier friendship with an older Viennese doctor, Josef Breuer. Breuer, who had helped Freud financially and professionally early in his career, had also related to him, in 1882, the story of his patient Anna O. and her treatment by the "cathartic method" that she and Breuer had invented. Having experimented with hypnosis for a period of time, Freud had determined that it was ineffective, especially after an 1889 visit to Nancy to see Hippolyte Bernheim, Charcot's rival. He then decided to make use of the "talking cure" Breuer had mentioned. This involved, in the attempt to overcome the patient's resistance, bringing back to consciousness an apparently forgotten memory, which had been repressed, of the first appearance of a symptom. This made hypnosis no longer necessary; gradually, the technique of incessant questioning it had given way to was in turn abandoned, in favor of the free association of ideas. Freud had developed the hypothesis of the unconscious, together with the idea that disturbances had their origin in the history of the subject's infantile sexuality.

These statements were shocking to many, especially because of Freud's public intransigence concerning them, and it was not without considerable reluctance, ultimately leading to the end of their friendship, that Josef Breuer agreed to cosign the *Studies in Hysteria* in 1895. Wilhelm Fliess remained his only confidant and the only one who listened to his theoretical suggestions and the results of his day-to-day clinical observations. Sexual etiology and childhood seduction by a parent were among the earliest etiological ideas, but the death of his father in October 1896 led Freud to question these ideas, and to practice the same methods on himself he had been using on his patients. His self-analysis continued throughout the summer and fall of 1897 and the discoveries followed: psychic reality, the Oedipus complex, and so on. Under various forms Freud would continue to question himself, as shown by his statement to James Jackson Putnam in 1911—"A self-analysis must be continued indefinitely. I note, in my own case, that each new attempt has brought surprises" (November 5 letter)—and the article dedicated to Romain Rolland, "A Disturbance of Memory on the Acropolis." (1936a)

Prompted by the frequency with which his patients spontaneously reported their dreams to him, Freud began to investigate their unconscious meanings. The first dream to which he applied his new method of interpretation through the fragmentation and association of ideas was the "injection given to Irma," of July 23, 1895. His systematic investigation of this dream became the origin of *The Interpretation of Dreams*, published at the end of 1899, but dated 1900 (1900a). It is a fundamental work in what Freud had referred to for the first time in 1896 (in an article published in French in the *Revue neurologique*) as "psychoanalysis."

The book was widely praised but sold poorly (421 copies in six years), although this did not impede his work. It was a period in which he described himself as a "conquistador," thereby summarizing the mixture of enthusiasm and obstinacy that characterized his personality. Anxious, suffering from hypochondriacal illnesses of the stomach and heart, preoccupied with the calculation of dates predicting his death, undecided about whether to continue or abandon smoking; there is nothing of the austere scholar depicted by his biographers. But he was primarily an indefatigable worker, who stayed up late at night to answer letters (a correspondence estimated at more than twenty thousand letters) and would fill large sheets of paper with his broad gothic handwriting.

As his friendship with Fliess waned, he prepared the *Psychopathology of Everyday Life* (1901b) and took notes for the Dora case, which was not published until 1905. Some of those who attended his courses at the university went to see him, either to be treated, like Wilhelm Stekel, or to discuss innovative theories with him. They formed the "Wednesday Psychological Society," which met every week and, in 1908, became the first Vienna Psychoanalytic Society. The publication of *Jokes and their Relation to the Unconscious* (1905c) and *Three Essays on the Theory of Sexuality* (1905d); followed by a collection of his earliest articles, *Sammlung kleiner Schriften zur Neurosenlehre aus den Jahren 1893–1906* (1906b); helped him break out of what he described as his "splendid isolation." Readers intrigued by the originality of his hypotheses came to visit him in Vienna: Max Eitingon in January 1907, Ludwig Binswanger and Carl Gustav Jung in February, Karl Abraham in December 1907, Sándor Ferenczi in February 1908. They were to form the core group of his future disciples.

In response to the growing number of followers and the high level of interest, the first International Psychoanalytical Congress was held in Salzburg on April 27, 1908. Freud spoke for nearly five hours on the Ratman (1909d), a case which, by systematizing non-directivity, helped establish the parameters of the psychoanalytic “framework.” Here the patient was stretched out on a couch with the psychoanalyst seated behind him, out of sight of the patient, sessions were held daily and lasted for about an hour, the patient was free to say whatever he wished. Freud laid down the groundwork for the theory of “transference” with the therapist and, in 1910, in response to Carl Gustav Jung’s affair with his patient Sabina Spielrein, the theory of the “counter-transference.” That same year, the risks of “wild” psychoanalysis led to the creation, at Ferenczi’s initiative, of an international psychoanalytic association to monitor the development of “die Sache” (the cause) and distinguish the wheat from the chaff among its practitioners.

Although Freud maintained friendly relations with Sándor Ferenczi—notwithstanding periods of tension and the short analysis his younger colleague began with him in 1914—until Ferenczi’s death in 1933, his relationships with his other students were often strained. Alfred Adler, who developed a theory based on aggression, the will to power, and organ inferiority, and rejected sexual etiology, distanced himself from Freud to found a new school in 1911. He was followed by Wilhelm Stekel in 1912. But the greatest disappointment came from Carl Gustav Jung, who in 1909 had been declared “successor and crown prince” by Freud, who had glimpsed the doors of academic psychiatry opening to him, along with the possibility that psychoanalysis would no longer be viewed as a “Jewish matter.” Their personal relationship, as shown in their correspondence, and the intellectual exchange this involved, encouraged Freud to study psychosis, using the *Memoirs of My Nervous Illness* by Daniel Schreber (1911c), and to speculate on anthropological issues, of which *Totem and Taboo* (1912–1913a) is the first expression.

However, Jung’s personality was such that he could not remain for long in the position of the submissive son, and his religious training and interest in mysticism led to no more than a superficial acceptance of Freud’s materialism and insistence on sexual etiology. This rejection of what was considered an outrageous and obscene “pansexualism” was fairly general, even

though Freud gradually enlarged the concept of sexuality, which the majority of his critics reduced to adult forms of genital sexuality. The concepts of “infantile sexuality” and “polymorphous perversity” were even more unacceptable to those who believed they sullied what was believed to be an original infantile purity.

As is often the case in such situations, Jung’s departure in 1914 served as a spur to Freud’s creativity, who wrote “On Narcissism: An Introduction” (1914c) and developed his analysis of the primal scene in his essay on the Wolfman, which he also completed that year (1918b [1914]). He also provided the first historical overview of the origins of psychoanalysis in *On the History of the Psycho-Analytic Movement* (1914d), which was intended to sway those who were still undecided between him and Jung.

The First World War seemed to sound the death knell for the young science of psychoanalysis. Freud’s sons were at the front and he initially supported a German victory. However, he soon revised his position, which he explained in “Thoughts for the Times on War and Death” (1915b). Times were difficult and material scarcity became a growing problem as war progressed. However, it was also a period of considerable intellectual creativity, and Freud laid out the groundwork for the broad theoretical foundations of psychoanalysis, primarily the twelve essays on metapsychology, only five of which (and the newly discovered draft of the twelfth) were published. In spite of his pessimism there was renewed interest in psychoanalysis among the public and within the medical establishment when it proved useful in treating war neuroses. The end of hostilities brought about a minor institutional triumph for, following the Fifth International Psychoanalytical Congress in Budapest (September 28–29, 1918), Béla Kun’s revolutionary government offered a university chair to Sándor Ferenczi. Another Hungarian, the rich brewer Anton von Freund, whom Freud analyzed, invested his fortune in “the cause,” which led to the creation of the Internationaler Psychoanalytischer Verlag, but he died of cancer in 1920.

Freud was sixty-five at this time, and around him he saw sickness and death. *Beyond the Pleasure Principle* (1920g) reflected this, with its theory of the repetition compulsion and the duality between a life impulse, Eros, and a death impulse, Thanatos, whose theoretical necessity Freud maintained until his death, despite the opposition of many psychoanalysts to such

“speculation.” In real life his daughter Sophie (he called her “Sunday’s child”) died during the Spanish flu epidemic, on January 25, 1920. Three years later, in April 1923, he experienced the first signs of cancer of the jaw, which had a profound effect on the remaining sixteen years of his life; that same year, on June 19, his favorite grandson, Heinele, died.

He was now sixty-seven years old and, although he often complained of growing old, this was but one of the many hypochondriacal conditions he had always referred to in his letters. His fear of death is most evident in his superstitious fears and morbid calculations, borrowed from Wilhelm Fliess, but the fateful days passed without event. Freud also showed considerable interest in telepathy and clairvoyance, and conducted experiments in this field, often together with Sándor Ferenczi.

In spite of his shortness, he was still the “professor” and was authoritarian with his family, his students, and his patients. He showed himself to be the undisputed leader of the psychoanalytic movement, interest in which he stimulated through his many publications. He had overcome pain and disappointment, and watched as the “cause” to which he had devoted his life continued to grow. Interest spread to France, and its identification with a founding father, a Moses—for Freud the creator of monotheism—seemed increasingly justified. It is in this context that his decision to become his daughter Anna’s analyst must be understood. This is not as unusual as it may seem, especially for the time, and Freud speaks of it in his letters. It was only after the Second World War that Anna Freud’s accession to the status of guardian of Freudian orthodoxy cast into oblivion a form of training so inconsistent with the strict criteria that had been laid out. There was a risk the lapse would be viewed as something very nearly incestuous.

With the onset of his cancer, old age and death became a reality for Freud. It was at this time that he strengthened the death instinct and deepened the concept of identification discussed in *Group Psychology and the Analysis of the Ego* (1921c). He also revised the theoretical model that he had been developing for the past quarter-century with the “second topographical” structure introduced in *The Ego and the Id* (1923b). Some of his contemporaries, like Otto Rank, were reluctant to accept Freud’s newest theories, which appeared to disturb the fantastic and somewhat unreal experience represented by the birth of psychoanalysis

for those who had lived through it. Freud’s life was now marked by painful and disfiguring operations that forced him to interrupt his activities while he recovered in the Weiner Cottage-Sanatorium or the Schloss Tegel clinic, which Ernest Simmel ran from 1927 to 1931 in Berlin. The uncomfortable prosthetic devices he was required to wear caused him to remain silent for long periods of time.

Change was in the works, however. There were disagreements within the secret committee, formed at the request of Ernest Jones in 1912 to provide support for Freud during Jung’s defection, and it ceased to exist entirely in 1927. The quarrels weren’t so much about who would inherit Freud’s mantle, as they were about jealousies and rivalries, all of which helped feed Freud’s increasingly pessimistic—some would say realistic—vision of the human race. The first generation of psychoanalysts had evolved and began to develop their own theories. It often fell to Freud to resolve the resulting theoretical disputes and arbitrate personal conflicts.

Freud never claimed to be a great therapist and was often irritated by the “*furor sanandi*” shown by some of his followers, notably Sándor Ferenczi, as being contrary to a strictly psychoanalytic attitude. Although he had encouraged the use of “active technique” in 1918–1920, he hesitated to complete the project for a “psychoanalytic method” that his followers demanded of him and which he had begun to write down in 1908. During this last period of his life, he devoted himself almost exclusively to training analyses. Having been a patient of Freud was widely viewed as a kind of diploma, and there was an unending stream of candidates, especially from North and South America.

His theoretical interest turned increasingly to what he felt to be his most important contribution: the importance of psychoanalysis to culture. It was in keeping with this that he resumed his anthropological ideas about the primitive horde and the murder of the primitive father, which had been introduced in *Totem and Taboo* (1912–1913a), extending their scope with the new theory of impulses, the importance of primal fantasies, and the concept of primary identification (in 1923b). In *The Future of an Illusion* (1927c), Freud analyzed religious sentiment; aside from being an affirmation of his scientific and materialist beliefs, the book also served as a warning against the religious leanings that jeopardized psychoanalysis. *Civilization and its Discontents* (1930a) resumed the discussion of

human destiny, torn between its contradictory impulses and condemned to negotiate the avoidance of suffering for its survival. Freud's focus on culture in his writings became increasingly obvious; he described a "process of civilization" whose evolution paralleled the process of mental development in the individual. The last essay, "*Weltanschauung*," in the *New Introductory Lectures on Psychoanalysis* (1933a) resumed these themes, which had also been discussed in his letter to Albert Einstein, "Why War?" (1933b), but it was in *Moses and Monotheism* (1939a) that Freud outlined the last great fresco of man's relation to culture, which continued to preoccupy him.

Freud continued to refine psychoanalytic theory. The second topographical model and the theory of impulses, "our mythology," as he called it in 1933, as well as upheavals in the psychoanalytic movement, led to new considerations and refinements. *Inhibitions, Symptoms and Anxiety* (1926d) is a response to the reduction of the Oedipus theory to the "birth trauma" proposed by Otto Rank in 1924, the first manifestation of a defection that would continue until 1926. "The Dissolution of the Oedipus Complex," (1924d) "Some Psychical Consequences of the Anatomical Distinction between the Sexes," (1925j) and "Female Sexuality" (1931b) provide an outline of the libido that was supported by the work of the first female psychoanalysts. The emphasis on a phallic phase responded to the criticism of Ernest Jones on Freudian views about femininity, discussed in chapter 30 of the *New Introductory Lectures* (1930a). There, Freud insists on the primordial role played by the threat and fear of castration. The ego defenses raised to counter the threat led Freud to introduce elements for a new approach to perversion, which he did in "Negation" (1925h). "Fetishism," (1927e) and his final manuscript, "Splitting of the Ego in the Process of Defense." (1940e [1938]) Freud gave increasing consideration to the death impulse in his clinical work and eventually it became not speculative but a key element of his theory, in spite of the opposition of many of his students.

Some of his older students passed away—Karl Abraham in 1925 and Ferenczi, who had grown distant from him, in 1933. The most important person in Freud's circle was now Anna, his daughter. While she was undergoing analysis, Freud arranged her initial contacts with the Vienna Psychoanalytic Society, to which she was elected a member in 1922. The worsening of his cancer and subsequent infirmity led to his

becoming increasingly dependent on his "Antigone," who began to represent him at conferences and accepted the Goethe Prize in his stead, when it was awarded in 1930 by the city of Frankfurt to acknowledge the literary value of his writing. She took his place at the funeral of his mother, Amalia Freud-Nathanson, who died at the age of ninety-five in September 1930. It is easy to understand why Freud looked askance at Ernest Jones and English psychoanalysts when, in 1925, they welcomed Melanie Klein and her theories, which contradicted the views of Anna Freud on child psychoanalysis.

Moreover, the Old World was crumbling, incapable of stopping the rise of Adolf Hitler. Freud's books were burned publicly in May 1933, and Jewish psychoanalysts were forced to flee or condemned to death. Initially, Freud negotiated in the hope of preserving the "cause," but the *Anschluss* forced him to face the bleak reality. With the assistance of Princess Marie Bonaparte, who, after an analysis begun in 1925, had become an attentive and influential friend, and the U.S. Ambassador William C. Bullitt, with whom he had attempted to write a psychological study of President Woodrow Wilson (1966b), he was able to emigrate with his wife and daughter to Great Britain on June 6, 1938. His other children as well as his brother Alexander left Austria, but his four sisters remained in Vienna; they died in the Nazi concentration camps in 1942 and 1943.

The "*peau de chagrin*" (Balzac's novel was one of the last books he read) began to tighten around Freud, who had settled on the outskirts of London, where he continued to write and see patients. The onset of the Second World War on September 1, 1939, and his physical decline led him to ask Max Schur, his doctor, to keep the promise they had made when they first met: not to give him a sedative but to shorten his suffering when he felt the hour was near. He died on September 23, 1939, and three days later his ashes were placed in a Greek urn that, knowing his fondness for antiques, Marie Bonaparte had given him.

Freud's death did not go unnoticed in spite of the upheavals in Europe and elsewhere. Aside from the eulogies and numerous critical assessments, it marked the beginning of a considerable expansion of psychoanalysis that began in the United States, a country Freud claimed to have little liking for. It also resulted in an astonishing idolization of Freud in the years following the war. For a time, under the impetus of the

lengthy biography written by Ernest Jones, Freud became a subject for hagiography; mention of his name took the place of original thinking and the “return to Freud” served as a theoretical pretext, for others as for Jacques Lacan in France. The home at Maresfield Gardens, where Martha Freud died in 1951, became, under the watchful eye of Anna Freud, the center of Freudianism and, after her death in 1982, was transformed into a museum, as was Freud’s apartment at Berggasse 19 in Vienna. In New York, Kurt Eissler began gathering documents and eye-witness accounts of Freud for the Freud Archives. However, because of his demand for secrecy, this material was for years kept from researchers, arousing their anger, exciting their curiosity, and giving rise to a number of spiteful rumors.

By the 1960s Freud’s books were often bestsellers. The body of Freud’s writings increased with the publication of his correspondence to his students and friends. His letters to Wilhelm Fliess, purchased in 1937 by Marie Bonaparte and miraculously preserved throughout the Second World War, provided insights into the birth of psychoanalysis, a theme that was to serve as inspiration for filmmakers and dramatists (among others, John Huston’s film, *Freud*, of 1962). Unfortunately, some passages were censored, which led to the growth of research on an unexpurgated history of Freud and psychoanalysis. Paul Roazen helped promote these efforts with his study on the relationship between Freud and Viktor Tausk (1969), which emphasized Freud’s responsibility in the suicide of this brilliant student and triggered a backlash against “orthodox” Freudians by adversaries who, thirty years later, would be labeled “revisionists.” Ardent supporters and angry critics confronted one another on a regular basis. Freud and his ideas were called into question by an increasingly large number of people, in a way compensating for the glorious early years psychoanalysis. The number of essays and criticisms multiplied with the discovery of historical documents—some authentic, some not. The anger and bitterness of his critics became increasingly obvious, betrayed by the excess of the accusations: there was an alleged attempt on Fliess’s life, reports of lies about his patients or errors of diagnosis by a Freud who was hungry for glory, tales of a ménage à trois involving Minna Bernays, and rumors of an abortion. A band of “moralists” obsessed with the “truth” about Freud and Freudianism kept up the pressure, especially in the United States.

On a more serious note, after the leading biography by Fritz Wittels, which had irritated Freud in 1924, and the monument erected by Ernest Jones from 1953 to 1957, a number of books have been written to describe Freud’s life and work, by serious scholars: Max Schur (1972), Ronald W. Clark (1980), Peter Gay (1988). Some of these presented original, and often questionable, interpretations of Freud’s work, such as the biographies by Frank Sulloway (1979) and Marianne Krüll (1979). The gradual appearance of new documents and the opening of the secret archives opened the door to future research and new assessments of Freud’s importance for the history and evolution of the civilization of his time and for human thought.

ALAIN DE MIJOLLA

*Works discussed:* *Autobiographical Study, An; Civilization and its Discontents*; “Claims of Psychoanalysis to Scientific Interest” “Contributions to the Psychology of Love”; “Creative Writers and Day-Dreaming”; “Delusions and Dreams in Jensen’s ‘Gradiva’”; “Dostoyevsky and Parricide”; *Ego and the Id, The; Group Psychology and the Analysis of the Ego*; “Heredity and the Aetiology of the Neuroses”; *Inhibitions, Symptoms and Anxiety*; “Instincts and their Vicissitudes”; *Interpretation of Dreams, The; Introductory Lectures on Psychoanalysis; Jokes and their Relation to the Unconscious*; “Klinische Studie über die halbseitiger Cerebrallähmung der Kinder” [Clinical study of infantile cerebral diplegia]; *Leonardo da Vinci and a memory of his childhood*; “Lines of Advance in Psycho-Analytic Therapy”; “Metapsychologic Supplement to the Theory of Dreams”; *Moses and Monotheism*; Moses of Michelangelo, The”; “Mourning and Melancholia”; “Negation, The”; “Neurasthenia and Anxiety Neurosis”; *New Introductory Lectures on Psychoanalysis*; “Note upon the ‘Mystic Writing Pad’, A”; “Notes upon a Case of Obsessional Neurosis” (Rat Man); “On Narcissism: An Introduction”; “On the History of the Psychoanalytic Movement”; “On the Sexual Theories of Children”; *Phylogenetic Fantasy, A: Overview of the Transference Neuroses*; “On Transience”; “Project for a Scientific Psychology, A”; *Question of Lay Analysis, The*; “Recommendations to Physicians Practicing Psychoanalysis”; “Remembering, Repeating and Working-Through”; “Repression”; “Seventeenth-century Demonological Neurosis, A”; “Sexual Enlightenment Of Children, The”; “Some Psychological Consequences of the Anatomical Distinction between the Sexes”; *Studies on Hysteria*; “Theme of the Three Caskets, The”; “Thomas Woodrow Wilson, Twenty-eighth President of the United States. A Psycho-

logical Study"; *Three Essays on the Theory of Sexuality*; "Thoughts for the Times on War and Death"; "Totem and Taboo"; "Uncanny, The"; "Unconscious, The"; "Why War?"; "Wild' Psycho-Analysis."

### Bibliography

- Mijolla, Alain de. (1982). Aux origines de la pratique psychanalytique. In R. Jaccard (Ed.), *Histoire de la psychanalyse* (v. I, pp. 11–43). Paris: Hachette.
- . (1989). Images of Freud from his correspondence. *International Forum of Psychoanalysis*, 5, 87–110.
- . (1993). Freud, biography, his autobiography and his biographers. *Psychoanalytic History*, 1 (1), 4–27.
- . (1996). Un adolescent bien tranquille. Sig(is)mund Freud, 1870–1876. *Cahiers du Collège international de l'Adolescence*, 1, 231–267.
- Wittels, Fritz. (1924). *Sigmund Freud, his personality, his teaching, his school* (E. and C. Paul, Trans.). London: Allen & Unwin.

## FREUD'S SELF-ANALYSIS

Although Didier Anzieu's doctoral thesis (1975; trans. 1986) treated Freud's self-analysis, he had already published a briefer, more general text: *L'auto-analyse: Son rôle dans la découverte de la psychanalyse par Freud, sa fonction en psychanalyse* (Self-analysis: its role in the discovery of psychoanalysis by Freud and its function in psychoanalysis; 1959). There one finds, in addition to research on the self-analysis of the young Freud, a study of self-analysis in general, both in literature (the surrealists) and in the clinic, before and after treatment.

*Freud's Self-analysis* (1986) dropped the study of self-analysis in general and featured an epistemological and historical approach to Freud's self-analysis, primarily as revealed in *The Interpretation of Dreams* (1900a), in relation to the discovery of psychoanalysis.

Anzieu avoided classic biography (such as the one by Ernest Jones [1953–1957]) in order to apply the psychoanalytic method to its creator. His work is supported by a thorough chronological inventory of the documents of the self-analysis (dreams, screen memories, slips, instances of forgetting, and parapraxes) from 1895 to 1902, the date of the break with Wilhelm Fliess and the foundation of the Psychoanalytic Society of Vienna. A chronological list of the inventory itself is appended at the end of the work.

The central focus of the book is essentially an investigation into the subjective conditions that led Freud to create psychoanalysis. This focus is also part of a major preoccupation of Anzieu's, the psychoanalysis of creative genius (1974).

Especially notable in *Freud's Self-Analysis* are the creative subject's masochism, the mother's favoritism for the future genius, Freud's mentally active attitude in relation to the primal scene, the creative subject's "heroic identifications," and also the castration anxiety that tends to paralyze or destroy creativity. In this regard Anzieu emphasizes the supportive role played by Fliess, remarking along the way that there is no serious self-analysis if it is not spoken to someone.

At a time when the history of psychoanalysis still captured only limited interest in France, Didier Anzieu produced both a reference work for researchers and a valuable example of the inseparability of psychoanalytic theory from the history of the discovery of its concepts, and thus from its authors.

SOPHIE DE MIJOLLA-MELLOR

*See also:* Anzieu, Didier; Self-analysis.

### Source Citation

- Anzieu, Didier. (1986). *Freud's self-analysis* (Peter Graham, Trans.). Madison, CT: International Universities Press. (Original work published 1975)

### Bibliography

- Anzieu, Didier. (1959). *L'auto-analyse: Son rôle dans la découverte de la psychanalyse par Freud, sa fonction en psychanalyse*. Paris: Presses Universitaires de France.
- . (1974). Vers une métapsychologie de la création. In Didier Anzieu (Ed.), *Psychanalyse du génie créateur* (pp. 1–30). Paris: Dunod.
- Freud, Sigmund. (1900a). The interpretation of dreams. *SE*, 4: 1–338; 5: 339–625.
- Jones, Ernest. (1953–1957). *Sigmund Freud: Life and work*. London: Hogarth.
- Mellor-Picaut, Sophie. (1977). Le travail de la création dans "L'autoanalyse de Freud et la découverte de la psychanalyse" par Didier Anzieu. *Psychanalyse à l'université*. 2 (8), 707–724.

## FREUD, THE SECRET PASSION

The first film made about Sigmund Freud, *Freud, the Secret Passion* was directed by John Huston and was based on a very long script proposed by Jean-Paul Sartre in 1958 but reworked by Charles Kaufmann and Wolfgang Reinhardt (Sartre insisted that his name not appear in the credits); it featured Montgomery Clift in the role of Freud and Susannah York in the role of Cecily Koertner. Released in 1962, it was distributed in France under the title *Freud, désirs inavoués*.

The film tells the story of the treatment by hypnosis of an hysterical patient, Cecily, by the young Freud, who struggles to bring her into awareness of the sexual origins of her problems and runs up against hostility from those close to her. Freud almost invariably looks furious, “somber,” “stiff,” “ashen-faced”—stuck in the shackles of his neurosis until he achieves a state of lucid Sartrean consciousness by getting rid of the protective and hated father figures with whom he had surrounded himself. Pushed by the hostility of the Viennese medical community, spurred on by anti-Semitism, he becomes “engaged,” according to Sartre’s ideas, in a revolutionary combat for the liberation of oppressed hysterics, unjustly called “fakers.” He is constructed in the image of the author-philosopher, who was known for repeatedly taking a stand in defense of blacks, the Algerians, Jews, workers, or those who, like Jean Genet, had been labeled from childhood and condemned to be what others had designated them to be.

It is these violent external conflicts, symbolized by the three “fathers” who appear—an alcoholic Theodor Meynert, a senile Jakob Freud, and a lame Josef Breuer—that for Sartre constitute the main motivation for Freud’s actions, although Sartre poses an additional, underlying question: What was Freud’s sexuality? The film glosses over this aspect of the script and of Sartre’s explanation of Freud’s violence by means of a sexual contention that remains inexplicable and unexplained. “But your Freud, he was neurotic down to the marrow!” Sartre once said jubilantly to Jean-Bertrand Pontalis (Pontalis in Sartre, 1984/1985).

On July 15, 1958, considering Ernest Jones’s hagiography of Freud, Simone de Beauvoir noted in her journal: “Jones doesn’t explain very well what Freud’s particular neurosis was, nor how he got rid of it. Perhaps the fact that Freud’s daughter is still alive embarrasses him, but there are certain questions he doesn’t ask: Freud’s relationship with his wife, for example. It’s

easy enough to say that they [sic] were ‘excellent’; but Freud’s depressions and migraines are either directly linked to his domestic life or they are not. Which? After all, he was an extremely vital man; witness his passionate love of travel. Monogamous, all right; but why, exactly? Jones avoids the question. . . . The most moving moment is the one where he discovers his mistake about hysteria. He had believed that all his women patients had been ‘seduced’ by their fathers . . . and he realized that his patients had invented it all. What a slap in the face! What a shock! . . . It is moving to watch these concepts that have become so scholastic, mechanical—transference for example—reveal themselves in such vital experiences” (1963/1965, pp. 430–431).

In a 1965 interview, Huston confided to Robert Benayoun: “The basic idea of Freud the adventurer, the explorer of his own unconscious, was mine. I wanted to concentrate on this episode like in a detective plot.” He also explained: “To me, hypnosis is something magical, almost sacred” (Benayoun, 1965).

And indeed, the hypnotic treatment and catharsis are what are presented to the public. Huston’s Freud conforms to the classic movie character who, one against all, and above all, against himself, must make triumphant a truth that he reveals through pain. Despite the sugar-coatings he added to the original script, Huston had to submit to the explicit and implicit imperatives of American censorship and adapt his film to the then-dominant ideological demands of the world of psychiatry and psychoanalysis. He later deplored the fact that his film had been “literally mutilated of its essential scenes” (Benayoun, 1965).

Many were concerned that Freud’s image might be ruined by his promiscuity in overly shocking scenes. It was essentially Anna Freud who opposed the idea of any film on her father. It is known, for example, that through the intermediary of Marianne Kris, she convinced Marilyn Monroe (who had consulted her during a shoot in London) not to play the role of Cecily, which Huston had in mind for her, according to Donald Spoto’s *Marilyn Monroe: The Biography* (1993). She also opposed the idea of any living member of the family being represented, which explains the childless marriage attributed to Freud onscreen. The theme of prostitution, which Sartre emphasized so constantly that it can be wondered whether this was his answer to his questions about Freud’s sexuality, was also strongly challenged by Hollywood’s censors, advised by some

eminent psychoanalysts (Walker, 1993). At the time, as Pontalis pointed out, studies of the history of psychoanalysis were virtually nonexistent.

Although the film can be criticized on many counts, its great merit must be acknowledged; it helped to shatter the conventional portrait of an old, stern, bespectacled, and white-bearded Freud. Even though it may seem artificial, excessive in the grimaces and wounded looks given by Montgomery Clift, the character seen onscreen made it possible, in its day, to imagine a Freud who was closer to the young viewers discovering him for the first time.

*See also:* Cinema and psychoanalysis; France; Sartre and psychoanalysis.

### **Bibliography**

Beauvoir, Simone de. (1965) *Force of circumstance: The autobiography of Simone de Beauvoir* (Richard Howard, Trans.). New York: Putnam. (Original work published 1963)

Benayoun, Robert. (1965). Interview de John Huston. *Positif*, 70.

Mijolla, Alain de. (1999). Freud and the psychoanalytic situation on the screen. In *Endless night. Cinema and psychoanalysis: Parallel histories* (pp. 188–199). Los Angeles and London: University of California Press. (Original work published 1994)

Sartre, Jean Paul. (1985). *The Freud scenario* (Quinton Hoare, Trans.). London: Verso. (Original work published 1984)

Spoto, Donald. (1993). *Marilyn Monroe: The autobiography*. New York: HarperCollins.

Walker, Janet. (1993). *Couching resistance: Women, film, and psychoanalytic psychiatry*, Minneapolis: University of Minnesota Press.

---

## **FREUND TOSZEGHY, ANTON VON (1880–1920)**

Anton von Freund Toszeghy, director of a brewery in Budapest, Hungary, a doctor of philosophy, and a patron of the psychoanalytic movement, was born in 1880 in Budapest and died on January 20, 1920, in Vienna, Austria. The son of a rich, ennobled industrialist who founded the state brewery of Steinbuch A. G., von Freund spent an idyllic childhood with his

brother, Emil (later codirector of the brewery with him), and two sisters on a magnificent property, the remains of which are still visible next to the brewery. Here Sigmund Freud spent the summer of 1918, far from the penury of wartime, receiving visits from Sándor Ferenczi, going for carriage rides along the Danube, correcting proofs of his articles, and analyzing one of von Freund's sisters, Kata (the future wife of Lajos Lévy, a physician, analyst, and director of the Jewish Hospital).

Von Freund underwent analysis with Freud and even directed a course of an analysis, which he reported on to Freud. The two men became friends, and von Freund went on to play an important role in the psychoanalytic movement. An eminent figure in Budapest, and practical and generous in temperament, he was initially the main organizer of the Fifth Congress of 1918 and was the founder of the first center for research on child psychology (for which he recruited Melanie Klein, one of Ferenczi's patients). He financed the publishing house Internationaler Psychoanalytischer Verlag in Vienna as well as an analytic outpatient clinic in Budapest (the latter was never actually created). He died prematurely of cancer, and Freud composed a moving obituary for this "providential" man.

MICHELLE MOREAU RICAUD

*See also:* *Beyond the Pleasure Principle*; Hungary; Internationaler Psychoanalytischer Verlag.

### **Bibliography**

Freud, Sigmund. (1920). Dr. Anton von Freund. *SE*, 18: 267–268.

---

## **FRIEDLÄNDER-FRÄNKL, KATE (1902–1949)**

Kate Friedländer, psychoanalyst and physician, was born in Innsbruck, Austria in 1902, and died February 20, 1949, in London.

Kate Friedländer's birthplace was one of the most anti-Semitic parts of Austria, and her parents were middle-class Jews. Her two brothers both died in early childhood, and she had a gifted younger sister whom she greatly admired.

She obtained her medical degree at the University in 1926, but frustrated by the narrow outlook in her



native town, she left for the Weimar Republic and settled in Berlin. There she became an assistant to Professor Karl Bonhoeffer at the University psychiatric clinic (The Charité), where many of the young doctors were interested in psychoanalysis. In 1930 Kate Friedländer obtained her second medical degree. She was interested in neurology and in 1932 published a paper titled "A Clinical Entity to be separated from Multiple Sclerosis." She wrote other papers, including one on general paresis and the social integration of those who had been treated for this condition with malaria therapy. This reflected her keen interest in social affairs and strong social conscience, an interest reflected in her involvement in the Juvenile Court in Berlin. Her interest in delinquency lasted all through her professional life. Two of her early papers, "The Somatic Origin of Anxiety" (1933) and "The Biological Basis of Freud's Theory of Anxiety" (1935), proclaimed her deep interest in this subject.

Friedländer's achievements in Berlin, and her pleasure in them, were overshadowed by the success of the Nazis. Together with her husband and two-year-old daughter, she emigrated to London in 1933, to become first an associate and then a full member of the British Psychoanalytical Society. In 1936 she took her third medical degree in Edinburgh, and in 1943 her D.P.M., in London. Her husband became increasingly mentally ill and, although she fought hard to save her marriage, the first steps toward an eventual divorce were taken in 1935.

Although her interests were wide, Kate Friedländer's contributions to psychoanalysis developed along two main lines, one linked closely with Edward Glover and the other with Anna Freud. In the 1930s she had already pursued her interest in delinquency and joined Glover in the Institute for the Study and Treatment of Delinquency; she published a book, *The Psycho-Analytic Approach to Juvenile Delinquency*, in 1947. With the arrival of Anna Freud she was greatly stimulated by her work with children and by the eventual creation of the War Nurseries. It was she above all who persuaded Anna Freud to found the child training course, in which she took an active part and which later became an integral part of the Hampstead Child Therapy Course and Clinic—an enterprise that would have delighted her had she lived to see it.

It was her remarkable vision and energy that led her to set up Britain's first Child Guidance Clinic—that of West Sussex, of which branches were opened in Horsham, Chichester and Worthing, supported by

enthusiastic students who had worked in the Hampstead Nurseries. These are the achievements for which she is best remembered. She played as well a full part in the life of the British Psychoanalytical Society, and submitted a number of written statements to the special meetings on the Controversial Discussions. But when Edward Glover, whom she strongly supported, resigned from the Society in 1944, she withdrew as well.

She was a keen and active sportswoman, an adventurous swimmer who defied tide and uncongenial weather, fond of tennis, skiing, ice-skating, and mountaineering. She died, with a great deal still to offer, on February 20, 1949, from carcinoma of the lung with brain secondaries, at the early age of forty-six, with her second husband, a well-known radiologist, at her bedside.

CLIFFORD YORKE

See also: Controversial Discussions; Great Britain.

### Bibliography

- Friedländer, Kate. (1940). On the longing to die. *International Journal of Psycho-Analysis*, 21, 416–426.
- . (1941). Children's books and their function in latency and pre-puberty. *Internationale Zeitschrift für Psychoanalyse*, 26.
- . (1945). Formation of the anti-social character. *Psychoanalytic Study of the Child*, 1, 189.
- . (1949). Neurosis and home background, a preliminary report. *Psychoanalytic Study of the Child*, 3–4, 423.
- King, Pearl H. M.; and Steiner, Riccardo. (1991). *The Freud-Klein Controversies, 1941–1945*. London-New York: Tavistock Publications-Routledge, New Library of Psychoanalysis.

## FRIENDSHIP

From a psychoanalytic viewpoint, friendship is one of the bonds that arise from sexual impulses when their attainment of a directly sexual goal is inhibited. However, this is a process of inhibition rather than sublimation. This approach to a sexual satisfaction that is never consummated forms the basis for especially strong and enduring ties between people.

Both in adolescence and in adulthood, Freud had some intense and deep friendships, but he did not

write on this subject at any great length. However, friendship, as he defined it, plays a key role between individuals to the extent that it appears as a metaphor for those relationships between two people that, unlike the state of romantic love, lead to a broader form of unity. In this sense, Freud connects it with these other ties that are based on the aim-inhibited sexual impulses: the tender relationship between parent and child, and conjugal love in which the sexual relationship has gradually fallen into second place. These two bonds form the basis for the broader unity that is constituted by the family, just as friendship is the foundation for the creation of social ties.

However, these different kinds of bond should not be confused, because the homosexual libido can develop into friendship whereas the conjugal bond is in essence heterosexual and the parent-child relationship involves an elaboration of the parent's narcissistic libido. These ties can even conflict: "a pair of lovers are sufficient to themselves, and do not even need the child they have in common to make them happy" (1930a [1929], p. 108).

At the theoretical level, Freud refined the concept of sublimation by distinguishing it from the inhibition of the aim of sexual satisfaction and, in this respect, friendship constitutes a good example. Using the examples of Plato and St. Paul (1921c), Freud emphasized that the libido corresponds to love understood in a wide sense, including, along with the state of romantic love, self-love, filial and parental love, friendship, and even the attachment to physical objects and abstract ideas. The sexual basis of these ties is attested to by the fact that they retain some of the primary sexual aims: "Even an affectionate devotee, even a friend or an admirer, desires the physical proximity and the sight of the person who is now loved only in the 'Pauline' sense" (pp. 138–139).

However, these aim-inhibited drives are not only capable of being combined with non-inhibited drives but can also be transformed back in the opposite direction to revert to the directly sexual form from which they have originated. Friendship, admiration, and even the religious bond therefore remain close to the sexual bond itself.

There is a particular kind of friendship that merits further consideration—the form that is shared by male homosexuals and leads to the formation of social ties. In relation to Daniel Paul Schreber, Freud wrote

that homosexual tendencies "help to constitute the social instincts, thus contributing an erotic factor to friendship and comradeship, to *esprit de corps* and to the love of mankind in general. How large a contribution is in fact derived from erotic sources (with the sexual aim inhibited) could scarcely be guessed from the normal social relations of mankind" (1911c [1910], p. 61). He bases this on the hypothesis that the shared homosexual impulse is generally aim-inhibited and constitutes a source of unused libido that is therefore available for these various ties. Moreover, the degree of homosexual drive in an individual determines their particular capacity for forming such ties, provided that they continue to inhibit it from direct satisfaction.

This highly simplistic economic perspective, which ignores the entire tradition of homosexual friendship in antiquity and mentions only the form that is not aim-inhibited, is somewhat baffling. This is a long way removed from the depth of Freud's analysis of the resexualization of sublimated homosexual ties that leads via narcissism to paranoia (1911c [1910]). However, Freud continues to subscribe to this specific affinity between the homosexual bond and the constitution of the group through friendship and *esprit de corps*: "It seems certain that homosexual love is far more compatible with group ties, even when it takes the shape of uninhibited sexual tendencies" (1921c, p. 141).

While the "social sense," a "sublimated" (or, rather, inhibited) form of the male homosexual libido, may take the form of love of humanity, it can also be extended to a relatively large group. Solidarity is therefore the form of expression given to the recognition of what is identical to the self.

SOPHIE DE MIJOLLA-MELLOR

*See also:* Alter ego; Double (the); Eros; Homosexuality; Persecution; "Psycho-Analytic Notes on an Autobiographical Account of a Case of Paranoia (Dementia Paranoides)."

### **Bibliography**

Freud, Sigmund. (1911c [1910]). Psycho-analytic notes on an autobiographical account of a case of paranoia (dementia paranoides). *SE*, 12: 1–82.

———. (1921c). Group psychology and the analysis of the ego. *SE*, 18: 65–143.

**Further Reading**

Rangell, Leo. (1963). On friendship. *Journal of the American Psychoanalytic Association*, 11, 3–54.

Rubin, Lowell B. (1986). On men and friendship. *Psychoanalytic Review*, 73, 165–181.

**FRIGHT**

Fright, a state of sudden, extreme fear, is provoked either by a situation experienced as an external danger or by the feeling of a high probability of danger. Situations capable of causing fright are often associated with a risk of physical or mental death.

The term *fright* appeared in the Freudian corpus for the first time in the “Preliminary communication” (Breuer and Freud, 1893a) to the *Studies on Hysteria* (1895d). In this paper Freud evokes the links between certain forms of hysteria and traumatic neurosis, combined in the term *traumatic hysteria*. Unlike the physical expression of hysteria, the affect of fright is mental trauma.

In a clinical context, fright is accompanied by a state of shock and stupor or, more rarely, by disordered agitation. But ever since Freud, psychoanalytic clinical practice and theory have always emphasized the passivity of fright and total lack of preparedness of the subject in the face of the situation, which are due as much to the totally unforeseeable nature of the event as to the potential for concrete danger. It is in this sense that fright must be differentiated from fear (a concept implying a definite object) and anxiety (a central psychoanalytic concept connoting the anxious expectation of an external or internal danger that needs to be confronted). As with many concepts, this distinction between internal and external is primarily metaphoric. For example, “sexual fright” designates a cataclysmic eruption that has a disorganizing effect on the subject’s mental life. Fright is associated with the splitting of the ego, the castration complex, and the perception of reality.

In light of the distinctions above, the concept of fright deserves a place in modern psychoanalysis, for it allows psychoanalysts to accurately assign theoretical and clinical categories and to avoid terminological ambiguity.

CLAUDE BARROIS

See also: Castration complex.

**Bibliography**

Barrois, Claude. (1988). *Les névroses traumatiques*. Paris: Dunod.

Freud, Sigmund. (1923d [1922]). A seventeenth-century demonological neurosis. *SE*, 19: 67–105.

———. (1926d [1925]). Inhibitions, symptoms and anxiety. *SE*, 20: 75–172.

———. (1940c [1922]). Medusa’s head. *SE*, 18: 273–274.

Freud, Sigmund, and Breuer, Josef. (1893a). On the psychological mechanism of hysterical phenomena: Preliminary communication. *SE*, 2: 1–17.

**FRINK, HORACE WESTLAKE (1883–1936)**

Horace Westlake Frink, American psychoanalyst and physician, was born in 1883 in Millerton, New York, and died on April 19, 1936, in Chapel Hill, North Carolina.

A physician uncle in Hillsdale, NY, raised Frink, an orphan. He studied with Adolf Meyer while attending Cornell University Medical College, from which he received his medical degree in 1905.

Although Abraham Arden Brill, Frink’s first analyst in 1909, considered himself the most prominent analyst in America, after James Jackson Putnam’s death in 1918 Freud was unhappy with the prospects of the direction of his movement in the United States. Between 1921 and 1923, for two periods of analysis, Frink was in treatment with Freud in Vienna, and Freud decided Frink was the most brilliant of his American disciples, and picked Frink to replace Brill as his deputy in America.

Frink was married and had two children. He was a Gentile in a movement known for its many Jews, which could help account for Freud’s enthusiasm for him. At Freud’s direction he became president of the New York Psychoanalytic Society.

During Frink’s second analysis with Freud, Frink underwent a psychotic breakdown which Freud failed to recognize as such. Frink suffered so much depersonalization that he had to be taken care of for a time by a male attendant. Freud interpreted Frink’s difficulties as simply part of the analysis.

Earlier, back in New York, Frink had fallen in love with a patient of his, an immensely rich, Jewish, married woman named Angelika Bijur. Her husband, also in analysis, threatened a legal suit against what he thought was the misconduct of his wife’s analyst. Frink had guilt feelings about abandoning his first wife who, however, was willing to divorce for the sake of his health. Freud saw Frink’s new fiancée in Vienna and encouraged the new union. Shortly before the wedding the bride had her doubts about Frink’s stability. Freud, however, insisted that Frink’s analysis was “complete” and that he was fully able to go through with the marriage. Freud thought that the match would be good for the analytic movement.

Bijur’s first husband died of cancer, and shortly after the wedding Frink’s own first spouse passed away. Frink felt he was unable to carry on, and put himself under the psychiatric care of Adolf Meyer. Frink’s second wife repudiated Meyer’s recommendation of patience, and ended the marriage. She was furious at the way she thought that Freud had misled her, and irritated that he had blamed her for supposedly having failed Frink over money.

Frink did attempt a professional comeback after leaving the hospital. But at an analytic meeting in New York, Brill read a letter from Freud to another analyst stating that Frink was unfit to execute the commission to which Freud had appointed him, because he was suffering from a mental disorder.

Frink spent the next decade raising his children. He was able to live on the money they had inherited from their mother, which Angelika had given as part of the divorce settlement. Frink re-married in 1935, but was suffering from heart disease; he died at a hospital in a state of manic excitement.

Frink’s textbook *Morbid Fears and Compulsions* (1918) was the best psychoanalytic book of its kind in English at the time.

Frink, who had become the center of a great scandal, turned against analysis but did not in the remotest way blame Freud for what had happened. Freud thought that Frink’s demise was the last straw in Freud’s efforts to help the Americans, and it confirmed Freud in his anti-American prejudices.

PAUL ROAZEN

*See also:* United States.

### **Bibliography**

Frink, Horace. (1918). *Morbid fears and compulsions* New York: Dodd Mead.

---

## **“FROM THE HISTORY OF AN INFANTILE NEUROSIS” (WOLF MAN)**

The twenty-three-year-old Dr. Sergueï Pankejeff, alias the Wolf Man, first consulted Freud in the beginning of February, 1910, and became the subject of the longest and, by general consent, greatest of Freud’s case histories. Dr. Pankejeff’s health had collapsed in his eighteenth year after a gonorrheal infection, and by the time he met Freud, he was incapacitated and entirely dependent on an attendant. In Freud’s eyes, he had an obsessional neurosis; modern opinion favors the diagnosis of borderline pathology.

Dr. Pankejeff felt that he was caught off from the world by a “veil,” which could be torn away only after he received an enema. In a letter addressed to Sándor Ferenczi at the very beginning of the analysis, Freud wrote about his patient, “He would like to use me from behind and shit on my head.”

In the case history, Freud focuses on the patient’s early life. The very title of the case history, “From the history of an infantile neurosis,” indicates a drastic expository selection from the four and a half years of the patient’s first analysis with Freud. Freud used the case to demonstrate the lasting neurotic impact of conflicted infantile sexuality in order to refute the theories of Alfred Adler and Carl Jung. Despite Freud’s claim of a complete cure, the Wolf Man continued to be seriously ill for the remaining half century of his life and was seen by many therapists (for accounts of Dr. Pankejeff’s second analysis with Freud and the subsequent prolonged analysis with Ruth Mack Brunswick, see Gardiner, 1971).

The case history is noteworthy for having brought to attention the psychodynamics of the following phenomena: the primal scene (adults engaged in sex), the early oral organization of the libido, primary feminine impulses, deferred effects, the rare instance of a trauma arising from a manifest drama, the complexities of anal eroticism and the castration complex, and the multiple vicissitudes of an obsession. In a technical sense, the case is remarkable as an example of a most elaborate analysis of a dream, a detailed reconstruction of an infantile scene, and strategic reliance on forced

termination of the analysis. Given the paucity of transference between Dr. Pankejeff and Freud in the clinical setting, one may suspect that the case material was immeasurably better understood and more highly organized in Freud's mind than in the patient's.

Freud described a whole range of mental disturbances in Pankejeff's young life, ranging from infantile anorexia and panic attacks to deficient impulse control, phobia, entrenched sadomasochistic tendencies, and various symptoms of obsession. Because he emphasized oedipal-derived pathology, Freud attributed major importance to the primal scene and the castration complex. Capital events determining the patient's young life were a primal scene observed when he was one and a half, a threat of castration from his nursery maid Grusha about a year later, his sister's seduction when he was three and a quarter, his traumatic dream when he was four, the outbreak of symptoms of obsession a half year later, and hallucinations at the age of five.

In a mimetic gesture, Freud devotes part 4 of his case history to the traumatic dream that Pankejeff had at age four about wolves (whence the patient's pseudonym). According to Freud's minute reconstruction, which mined each detail of the dream, the primal scene of *coitus a tergo* (vaginal penetration from behind) observed by the patient as an infant finally returned much later in a dream when he was capable of a deferred understanding. After writing up the case in 1914, Freud himself had a deferred understanding about the authenticity of the early primal scene (Freud did not include that revision in part 4 but deferred its inclusion, and hence his readers' ability to understand it, until part 5).

Notwithstanding Freud's reserve about the factuality of the primal scene, his comparative elaboration of clinical material in the case history remains problematic. According to Freud, the Grusha scene was more certain than the primal scene (1918, 113 ff.), yet he mentions the Grusha scene on 12 pages, or 10 percent of the case (115 pages), whereas he refers to the "less certain primal scene" on 46 pages, or about 40 percent of the case. Such a discrepancy over what is salient in the very showpiece of Freud's case histories proportionately undercuts its intrinsic value.

Another salient feature of the case history is that the initial years of treatment produced hardly any change. Freud submitted his patient to a "long education"

before Pankejeff would share in the work of analysis, and once he did with any success, he forsook further cooperation. He thus became "unassailably entrenched behind an attitude of obliging apathy." Freud then took the drastic measure of unilaterally setting an irrevocable, fixed date for terminating treatment. Reacting to the pressure of a deadline, Pankejeff reportedly lessened his resistance and came forth with a flood of material that clarified Freud's comprehension of the infantile neurosis. In light of the patient's passive character and superficial compliance, many analysts hold that only Freud believed that there was a clinical breakthrough, not his patient.

PATRICK MAHONY

*See also:* Abraham, Nicolas; Disavowal; Infantile neurosis; Money and psychoanalytic treatment; Pankejeff, Sergueï; Primal fantasy; Primal scene.

#### Source citation

Freud Sigmund. (1918). From the history of an infantile neurosis. *SE*, 17, 1–122.

#### Bibliography

Freud Sigmund. (1918). From the history of an infantile neurosis. *SE*, 17, 1–122.

Gardiner, Muriel M. (Ed.). (1971). *The wolf-man by the wolf-man*. New York: Basic Books.

Mahony, Patrick J. (1984). *Cries of the wolf man*. New York: International Universities Press.

Smith, Joseph, and Humphrey, Morris (Eds.). (1992). *Telling facts: history and narration in psychoanalysis*. Baltimore: Johns Hopkins University Press.

Viderman, Serge. (1970). *La construction de l'espace analytique*. Paris: Denoël.

---

## FROMM, ERICH (1900–1980)

Erich Fromm, a German psychoanalyst and sociologist, was born on March 23, 1900, in Frankfurt, Germany, and died on March 18, 1980, in Locarno, Switzerland. He grew up in a Jewish family in Germany. From age eighteen to twenty-two he attended the University of Heidelberg, where he studied sociology, receiving his doctorate under the supervision of Alfred Weber. He wrote his thesis on Talmudic law in three separate Jewish communities. In 1924 he met Frieda Reichmann, who became his first analyst and

later his wife. At the time she was running a small sanatorium in Frankfurt. Fromm had two other analysts before he moved to Berlin, where in 1927 he was analyzed by the Viennese Hanns Sachs.

From the 1930s, after about ten years of being a traditional Freudian, Fromm began to look critically at the central moral and philosophical bases of Freud's writings. As a Marxist, Fromm was shrewd in spotting the middle-class, liberal assumptions Freud had taken for granted. As a psychologist, Fromm's special theoretical contribution was an understanding of the social forces that stabilize or undermine the political community. In *Escape from Freedom* (1941), a landmark in modern social science, Fromm enunciated the important concept of "social character" in building theoretical bridges between the study of the individual and the study of society. He was fascinated with the problem of social change and how sociological issues can be understood in the light of depth psychology. He also wanted to examine people in their social milieus. Fromm had his predecessors within psychoanalysis, the most notable perhaps being Wilhelm Reich, who also tried to synthesize Marxist and Freudian principles. Fromm has his detractors: not only strict psychoanalysts but also Marxist hardliners, who have been determined to dismiss Fromm as a so-called social democrat.

After Fromm fled from Nazi Germany in 1933, he moved to the United States, where he was soon in contact with a whole new school of analysts, anthropologists, and sociologists that became known as the neo-Freudian movement. This group included analysts like Harry Stack Sullivan, Karen Horney, Abram Kardiner, and Clara Thompson, as well as academics such as Margaret Mead, Ruth Benedict, and Ralph Linton. Fromm found that he had been quietly dropped as a direct member of the International Psychoanalytical Association. Despite this setback, he was made clinical director of the William Alanson White Institute in New York City, which focuses on training psychoanalysts, and served from 1946 until 1950.

In 1949 Fromm moved for much of the year to Mexico for his second wife's health. There he founded the Mexican Institute of Psychoanalysis, where his ideas are still being taught in a clinical context as of 2005. He also continued to write in his isolated retreat near Mexico City. Especially in Germany, where the International Erich Fromm Society is headquartered,

but also in Italy and elsewhere, Fromm's clinical concepts are still being extended.

Millions of people around the world read Fromm's works, but it has usually been his social philosophy that catches the public's attention. Works like *The Sane Society* (1955) represent a serious indictment of modern capitalist culture. *Man for Himself* (1947) was an early popular effort to extract a humanitarian core from analytic teachings. *The Art of Loving* (1956) is perhaps Fromm's best-selling book. *The Anatomy of Human Destructiveness* (1973) showed the comprehensive nature of Fromm's system of thought. *To Have or to Be?* (1976) was a widely read restatement of his attempt to connect humanistic Marxism with analysis. More technical works like *The Forgotten Language* (1951) and *Psychoanalysis and Religion* (1950) are of direct clinical relevance, even though they are no longer studied at most professional training centers.

Fromm was one of the first and boldest to challenge the ideological underpinnings of Ernest Jones's quasi-official three-volume life of Freud. In *Sigmund Freud's Mission* (1959) he gave a path-breaking response to the orthodox version of Freud's career and its controversies. For example, he asked some serious questions about Freud's relationship with his mother—a subject that has not received adequate attention in the literature. Fromm also discredited Jones's account of the supposed mental deterioration of both Sándor Ferenczi and Otto Rank.

Fromm, one of the most conceptually clear-cut thinkers in the tradition of dissenting analysts, claimed to be truer to the intellectually radical implications of the spirit of Freud's thought than the organized following generally supposed to be Freud's heirs. One cannot correct some central problems where Freud could be mistaken by piously fixing translations or re-editing Freud's writings. By pointing out some of these central problems, Fromm ranks as an important critic of Freud's. Part of Fromm's strength came from a deep identification with Freud as a warrior of the spirit; to be genuinely like Freud meant also to be independent-minded. Fromm proved fearless in expressing his analytic convictions, even though the orthodox-minded to reacted to him by branding him as a dissenting voice.

PAUL ROAZEN

See also: Germany; Horney-Danielson, Karen; International Federation of Psychoanalytic Societies; Marxism and psychoanalysis; Mexico; United States; Politics and psychoanalysis; Sigmund Freud Institut.

### **Bibliography**

- Burston, Daniel. (1991). *The legacy of Erich Fromm*. Cambridge, MA: Harvard University Press.
- Fromm, Erich. (1941). *Escape from freedom*. New York: Holt, Rinehart, and Winston.
- . (1947). *Man for himself*. Greenwich, CT: Fawcett Premier Books.
- . (1950). *Psychoanalysis and religion*. New Haven: Yale University Press.
- . (1951). *The forgotten language: An introduction to the understanding of dreams, fairy tales, and myths*. New York: Rinehart.
- . (1955). *The sane society*. Greenwich, CT: Fawcett Premier Books.
- . (1956). *The art of loving*. New York: Harper.
- . (1959). *Sigmund Freud's mission: An analysis of his personality and influence*. New York: Harper.
- . (1973). *The anatomy of human destructiveness*. New York: Holt, Rinehart, and Winston.
- . (1976). *To have or to be?* New York: Harper and Row.
- Funk, Rainer. (1982). *Erich Fromm: The courage to be human* (Michael Shaw, Trans.). New York: Continuum.

---

## **FROMM-REICHMANN, FRIEDA (1889–1957)**

Frieda Fromm-Reichmann, psychoanalyst and physician, was born on October 23, 1889, in Karlsruhe, Germany, and died on April 28, 1957, in her cottage on the grounds of Chestnut Lodge, Rockville, Maryland, in the United States.

Fromm-Reichmann was the oldest of three daughters. Her father was a Jewish bank personnel manager and her mother founded a girls' school, which well prepared Frieda to be among the very first German university-trained women. She graduated in 1913 from the University of Königsberg medical school where her dissertation mentor was Kurt Goldstein, with whom she worked during World War I. As a major in the Prussian Army she ran a hospital for soldiers with

brain injuries. She then joined the psychotherapy staff of the Lahmann Sanatorium, Weisser Hirsch, under J. H. Schultz's directorship (1920–1924).

Fromm-Reichmann received her psychoanalytic training at the Berlin Psychoanalytic Institute (1925), where her training analyst was Hanns Sachs. She opened her own sanatorium where kosher food was served (nicknamed the "Thorapeuticum"), working closely with Georg Groddeck, as well as Sándor Ferenczi. She was married to Erich Fromm, who was ten years younger than she. This marriage lasted for about four years. Along with Karl Landauer, Heinrich Meng, Georg Groddeck, Siegfried Fuchs, and Franz Stein, they founded the Frankfurter Institut. With the onset of World War II she went first to Alsace-Lorraine, (1933–1934) then Palestine (1934), and in 1935 to the United States.

At Chestnut Lodge, as its Director of Psychotherapy, she helped its owner and medical director, Dexter M. Bullard, Sr., make it the premier center for the psychoanalytically-oriented treatment of schizophrenia, and worked closely with Harry Stack Sullivan. She was a training analyst of the Washington-Baltimore Psychoanalytic Institute and president of its Society (1939–1941), and a popular teacher at the Washington School of Psychiatry.

Her central thesis was that psychotic patients' communications are understandable, that they magnify their sense of their destructive potential and thus isolate themselves, suffering enormous loneliness and dread. If the therapist understands his or her countertransference and thus is not made anxious by the psychotic patient, recovery is possible. Essentially all psychiatrists trained during the 1950s, 1960s and 1970s read her book *Principles of Intensive Psychotherapy*. Joanne Greenberg, a patient of hers who recovered from schizophrenia, wrote the bestseller *I Never Promised You a Rose Garden*, in which Fromm-Reichmann appears as Dr. Fried.

ANN-LOUISE S. SILVER

See also: Germany; Psychotic transference; Schizophrenia; Sigmund Freud Institut; United States.

### **Bibliography**

- Bullard, Dexter. (1959). *Psychoanalysis and psychotherapy. Selected papers of Frieda Fromm-Reichmann*. Chicago: University of Chicago Press.

Fromm-Reichmann, Frieda. (1950). *Principles of intensive psychotherapy*. Chicago: University of Chicago Press.

Greenberg, Joanne. (1964). *I never promised you a rose garden*. New York: Holt, Rinehart and Winston.

Hornstein, Gail A. (2000). *To redeem one person is to redeem the world: The life of Frieda Fromm-Reichmann*. New York: The Free Press.

Silver, Ann-Louise. (Ed.). (1989). *Psychoanalysis and psychosis*. Madison, CT: International Universities Press.

## FRUSTRATION

The word *frustration*, now in common usage, refers to the state of someone who denies himself, or who is denied, drive satisfaction.

Beginning with “Heredity and Aetiology of the Neuroses” (1896a), a paper written in French, Freud identified sexual frustration as conducive to anxiety neurosis. In “My Views on the Part Played by Sexuality in the Aetiology of Neuroses” (1906a), to refer to frustrated excitation, he used the word “frustrane,” a word probably formed from the German verb “frustrieren” (to frustrate), which was in everyday usage. The German language has no equivalent to the substantive form “frustration,” which was later used in English and the romance languages to translate “Versagung,” the word used by Freud in a slightly different sense from the meaning it then had of renunciation and sometimes refusal to describe frustration. Freud was aware of this difficulty and did not neglect to discuss it.

In his article “Types of Onset of Neurosis” (1912c), Freud used the word “frustration” (*Versagung*) for the first time to describe both internal and external factors that cause neurosis. He wrote, “Psycho-analysis has warned us that we must give up the unfruitful contrast between external and internal factors, between experience and constitution, and has taught us that we shall invariably find the cause of the onset of neurotic illness in a particular psychical situation which can be brought about in a variety of ways” (p. 238). In essential particulars he continued to hold this view, going on to write, for example, about a narcissistic form of frustration.

The concept of frustration seems to cover the idea of privation, while sometimes going beyond it. Freud was aware of a conceptual difficulty here, and he attributed its resolution to psychoanalysis rather to the

innate genius of the German language. In *The Future of an Illusion* (1927c), he wrote, “For the sake of a uniform terminology we will describe the fact that an instinct cannot be satisfied as a ‘frustration,’ the regulation by which this frustration is established as a ‘prohibition’ and the condition which is produced by the prohibition as a ‘privation’” (p. 10). Later in this work he specified the drive urges subject to frustration, prohibition, and privation: incestuous, murderous, and cannibalistic wishes.

In the view of English-language authors, Melanie Klein in particular, frustration incites the reality principle and modulates psychic functioning. “Neurotic children do not tolerate reality well, because they cannot tolerate frustrations. They protect themselves from reality by denying it. What is fundamental and decisive for their future adaptability to reality is their greater or lesser capacity to tolerate those frustrations that arise out of the Oedipus situation” (Klein, 1975, pp. 11–12). Here the feeling of frustration appears to complement the idealizing impulse pointed out by Jean-Michel Petot (1982), who also suggested that the English term “deprivation” was closer to the German *Versagung*.

The connections made by Freud among frustration, prohibition, and privation form the basis for Lacan’s discussion of the connections between castration, privation, and frustration in his seminar on the object relationship (1994). Frustration there appears as an imaginary formation caused by the symbolic mother but related to the real breast; it prevents the subject from entering the symbolic dialectic of giving and exchange. Lacan writes, “Frustration essentially belongs to the realm of protest. It relates to something that is desired and not possessed but that is desired without reference to any possibility of gratification or acquisition. Frustration itself constitutes the realm of unbridled and lawless demands. This core of the concept of frustration as such is one of the categories of lack and an imaginary damnation. It exists at the imaginary level.” And later, “The early experience of frustration is only of importance and interest insofar as it leads to one or other of the two levels that I have set out for you—castration or privation. In truth, castration is simply that which accords frustration its true place, transcending it and establishing it within a law that gives it another meaning.”

Frustration for Lacan is nonetheless more than a mode of object relationship; it extends from an object



relationship to the very organization of speech and the ego. There is an inherent frustration in the discourse of the subject, and the feeling of frustration is a basic characteristic of the ego (Lacan, 1994). These propositions can be connected with Kleinian theories of the genesis and organization of the psychic apparatus.

It should be mentioned that on two occasions Lacan made Freud's use of the term *frustration* unnecessarily problematic. He asserted that it was of marginal importance in Freud's thought, whereas in fact it is central to his thought and Lacan himself deploys it as such (1994 [1956–1957]). Ten years later, far from correcting this viewpoint, he went so far as to assert that there was not the slightest trace of the term *frustration* to be found in Freud's works (1966). Lacan's persistent slip suggests that the expansion of the concept of frustration in psychoanalysis is the result of a misunderstanding or a translation error not only among German and English and the romance languages but above all between psychoanalysis and psychology, which at the time essentially based its observations, experiments, and theories on the conflict between frustration and gratification.

LUIZ EDUARDO PRADO DE OLIVEIRA

*See also:* Abstinence/rule of abstinence; Active technique; Anxiety; Archaic mother; Child analysis; Deprivation; Negative Capability; Primary need; Privation; Projection; Protothoughts; Psychological tests; Realization; Relaxation principle and neo-catharsis; Splitting; Splitting of the object; Subject's castration, the; Symbolic realization; Thought-thinking apparatus; Want of being/lack of being.

### Bibliography

- Freud, Sigmund. (1896a). Heredity and the aetiology of the neuroses. *SE*, 3: 141–156.
- . (1906a [1905]). My views on the part played by sexuality in the aetiology of the neuroses. *SE*, 7: 269–279.
- . (1912c). Types of onset of neurosis. *SE*, 12: 227–238.
- . (1927c). The future of an illusion. *SE*, 21: 1–56.
- Klein, Melanie. (1975). The psychological foundations of child analysis. In *The writings of Melanie Klein* (Vol. 2: *The psycho-analysis of children*; Alix Strachey, Trans.). London: Hogarth Press and the Institute of Psycho-Analysis.
- Lacan, Jacques. (1966). *Écrits*. Paris: Seuil.

———. (1977). *Écrits: A selection* (Alan Sheridan, Trans.). New York: Norton.

———. (1994). *Le séminaire*. Book 4: *La relation d'objet* (1956–1957). Paris: Seuil.

Petot, Jean-Michel. (1982). *Mélanie Klein*. (Christine Trollope, Trans.). Madison, CT: International Universities Press.

Siboni, Jacques. (1996). *Les mathèmes de Lacan: Anthologie des assertions entièrement transmissibles et de leurs relations dans les écrits de Jacques Lacan*. Paris: Lysimaque.

### Further Reading

Bacal, Howard. (1988). Reflections on 'optimum frustration.' *Progress in Self Psychology*, 4, 127–131.

Lowenfeld, Henry. (1975). Notes on frustration. *Psychoanalytic Quarterly*, 44, 127–138.

---

## FUNCTIONAL PHENOMENON

In his study on “hypnagogic” states (states between being awake and falling asleep) (1909/1951), which earned immediate publication and led him to make contact with Sigmund Freud in 1909, Herbert Silberer designated by the name “autosymbolic phenomenon” the visual image he saw when falling asleep that, upon analysis, could be understood as a representation in image form of his ideas at that moment. He gave the name “functional phenomenon” to what, in this process, represented not the object of his thought but how his mind was functioning—effortlessly, cumbersome, or vainly. In other words, the term refers to a symbolization of the thinking process itself, of the current activity of the mind, its affects, and its intentions.

In “On Narcissism: An Introduction” (1914c), Sigmund Freud, in his discussion of the role of moral conscience, offered a commentary that is as clear as it is full of praise: “It will certainly be of importance to us if evidence of the activity of this critically observing agency—which becomes heightened into conscience and philosophic introspection—can be found in other fields as well. I will mention here what Herbert Silberer has called the ‘functional phenomenon,’ one of the few indisputably valuable additions to the theory of dreams. Silberer, as we know, has shown that in states between sleeping and waking we can directly observe the translation of thoughts into visual images, but that in these circumstances we frequently have a representation, not of a thought-content, but of the actual state (willingness, fatigue, etc.) of the person who is strug-

gling against sleep. Similarly, he has shown that the conclusions of some dreams or some divisions in their content merely signify the dreamer's own perception of his sleeping and waking. Silberer has thus demonstrated the part played by observation—in the sense of the paranoid's delusions of being watched—in the formation of dreams. This part is not a constant one. Probably the reason why I overlooked it is because it does not play any great part in my own dreams; in persons who are gifted philosophically and accustomed to introspection it may become very evident" (pp. 96–97).

In Silberer's thought, analysis of functional phenomena resulted in an interpretation that increasingly evolved toward abstraction and generalization—"anagogical interpretation," which Freud criticized.

At the end of a lengthy critical examination of Silberer's theories in his article "The Theory of Symbolism" (1916/1948), Ernest Jones concluded, "Silberer, by first extending the term 'functional symbolism' from its original sense to cover the concrete representations of concrete processes in general, and by then confining it to the cases where these are secondary in nature, recedes from the conception of true symbolism and reaches once more the population conception of symbolism as the presentation of the abstract in terms of the concrete" (p. 127).

ALAIN DE MIJOLLA

*See also:* Anagogical interpretation; Silberer, Herbert.

### **Bibliography**

Freud, Sigmund. (1914c). On narcissism: An introduction. *SE*, 14: 67–102.

Jones, Ernest. (1948). The theory of symbolism. *Papers on Psychoanalysis*. Boston: Beacon Press. (Original work published 1916.)

Silberer, Herbert. (1911). Symbolik des Erwachens und Schwellensymbolik überhaupt. *Jahrbuch für psychoanalytische und psychopathologische Forschungen*, 3, 621–660.

———. (1951). Report on a method of eliciting and observing certain symbolic hallucination-phenomena. In David Rapaport (Ed.), *Organization and pathology of thought: Selected sources* (pp. 195–207). New York: Columbia University Press. (Original work published 1909)

———. (1971). *Hidden symbolism of alchemy and the occult arts* (Smith Ely Jelliffe, Trans.). New York: Dover. (Original work published 1914.)

## **FUNDAMENTAL RULE**

The fundamental rule, as set forth in "Freud's Psychoanalytic Procedure" (1904a [1903]), urges that patients say "whatever comes into their heads, even if they think it unimportant or irrelevant or nonsensical . . . or embarrassing or distressing" (p. 251). Implicitly, the rule urges analysts to adopt a corresponding listening technique ("evenly suspended attention"), for which they are prepared by virtue of what Ferenczi (1928, pp. 88–89) called the second fundamental rule, namely the requirement that future analysts be analyzed themselves.

The fundamental rule was an end-point in Freud's development of his technique. He had begun with the "cathartic method," using hypnosis to elicit a verbal discharge of affects attached to buried traumas. In an intermediary stage, he used "free associations" as a way of uncovering the latent meaning of manifest phenomena such as memories, symptoms, or dreams, but without as yet forgoing the constraining use of suggestion. His adoption of the fundamental rule marked the renunciation of suggestion and of all prior assumptions on the part of the therapist. By initially and always giving the right to speak to the patient, the rule designated him or her as the source of all knowledge. By insisting that both partners in the work of analysis proceed "without any purpose in view" (1912e, p. 114) the rule claims implicitly to institute a kind of independent authority or "third party" before which the sequence of psychic material demanded by the rule might be manifested, perceived, and put into words. This initial positive rationality for the rule gradually came into question as the complexity of what was involved became apparent.

By examining significant variations in the way the rule has been stated, it is possible to get the measure of its metapsychological implications.

1. The statement of the rule was at first intended as a purely negative recommendation: the patient must not, as he would in an ordinary conversation, reject the incidental thoughts that cross his or her mind. The idea is to lift the censorship so that the products of unconscious mental activity could be expressed.

To resolve the paradox resulting from the fact that this negative prescription assumes a patient who is already in the process of speaking, the rule was subsequently pared down by Freud to: "Say whatever goes through your mind" (1913c, p. 135). Thus, the

patient's "choice" of a topic was no longer differentiated from "any intrusive ideas that may occur to you" (p. 134). The result of this was that the patient had to attribute two functions to the rule simultaneously, making it both a source of freedom and an obligation to "tell all."

2. Freud's formulation of the rule created a basic disjunction between "whatever goes through the mind" and words used to report it. At first this distinction seems clear enough: The patient's utterances presumably result from a voluntary act, whereas "whatever goes through the mind" is involuntary and passively "received." Thus understood, the logic of the rule combines the supposed "immunity" of the act of speaking with an acceptance of the idea of a "passivity" that implies the suspension of the usual way in which meaning is assigned. This logic is supposed to lead the patient to a positive cathexis of "whatever goes through the mind" and its enigmatic origins. And "whatever goes through the mind," it should be recalled, is a heterogeneous category, including as it does not just ideas, images, or wishes, but also representations, sensations, feelings, pure affects (such as anxiety), bodily states, and so on.

3. Further reflection confronts us with the fact that this as-yet un verbalized material comprises "word-presentations"; it is therefore discursive in nature, which means that the discrepancy between what comes to mind and the act of reporting it is either invalidated or limited to the sphere of linguistic activity.

We can see how Jacques Lacan, as a result of this primordial importance of speech and language, was led to propose the following wording for the rule: "Say anything at all, without being afraid of saying something stupid." However, the disjunction evident in Freud's work remains in full force. An eloquent expression of it is the metaphor of traveling in a train. The patient is compared to the passenger seated by the window, who must describe to his traveling companion the scenery passing by, without paying special attention to any given aspect on a priori grounds. For Freud, the most important point was that the countryside being traversed can never be reduced to what the passenger can perceive of it and say about it. The disjunction between psychic activity and the activity of speaking preserves the heterogeneity of relationships that word-presentations may have with the various registers of psychic and physical reality. According to Freud, "whatever comes to mind" tends,

through the favored mode of regression toward the visual image, toward a hallucinatory realization that is similar to the dream and its primary processes.

The crucial phenomenon remains the transference, through which "what comes to mind" is aimed at the analyst to whom, simultaneously, the patient's speech is addressed. The postulate of the rule is that discourse can invest this transference relationship.

The statement of the rule alludes to certain critical judgments that the patient must disregard. The judgments that something is unimportant or nonsensical naturally attest to the ordinary aspiration to say important and logical things. The judgment against things that are "distressing" to say summarizes all the others. Thus, the conflict whose onset is postulated in the wording of the rule is one that, by attesting to the consistency of the patient's inner psychic conflict, ensures that the attempt to put the rule into effect will have a dynamic value. The analyst's task is thus to confront the unpleasure of telling. At the price of this unpleasure, overcoming resistance can be productive.

From a metapsychological point of view, we can consider that by requiring the lifting of repression, the rule opens up the unconscious, gives the repressed access to consciousness, under the sign of the pleasure principle. The resistances that attempt to close this door are based on ordinary rationality. However, under the aegis of an accepted rule, they are no longer anything other than rationalizations; they express the action of repression, which also derives from the pleasure principle, since its aim is to substitute a sort of flight by avoidance for the action of a psychic "reality principle" and the free judgment it makes possible.

We can conceive that "intrusive ideas" are derivatives of the repressed: They can be perceived and spoken because they are not too threatening to the censorship. At a certain threshold of instinctual investment, a certain proximity to the unconscious kernel, signal-anxiety triggers repression, which manifests itself as resistance. It is because the conflict between repressing and repressed is well "organized" that it reveals the topographical contradictions of the pleasure principle (what is pleasure in one place becomes unpleasure in another), and that by following the associative chains and the "compromises" whose traces they bear and the context this process creates, the analyst is enabled to "discover the repressed instinctual impulses which are feeding the resistance," according to Freud in "Remembering,

Repeating and Working Through (Further Recommendations on the Technique of Psycho-Analysis II)" (1914g, p. 155). In the same essay Freud defined the cure as a "working-through of the resistances" (p. 155). The aim of the rule is not to "free" unconscious material (as in hypnosis), but rather to support the most complete and most "free" manifestation of conflicting forces so that their interplay may be modified.

Let us highlight the complexity of the rule's inherent stakes and their metapsychological correlates:

a) The rule cannot be described as either impartial or exterior to the forces at work in the analysis. It is directly involved in the phenomena inherent in the processes of the cure and its indirect "goals" (symbol-formation, sublimation, transference onto speech, becoming-conscious): Putting it into effect is an end as much as a means.

b) Accordingly, the rule inevitably plays a role in the transference. Far from remaining a third locus, it is invested as an emanation of the analyst's desire that it will thus be possible to satisfy or disappoint. Mobilization of the conflict in response to the rule can be expressed in the form of a transference acting out (*Agieren*) inherent in the logic of the situation. But the massive nature of this mobilization and the instantaneous nature of making the rule the locus of conflict do not facilitate the task of interpretation.

c) It is thus clear that the rule necessarily summons up the transgressions that contest it, the events that illustrate the impossibility of completely putting it into effect. It is only realized through that which seems to negate it: the activation of modes of "magical" or animistic thinking, which subvert the very existence of an observing ego, of a reality principle applied to psychic space. Any reference, even implicit, to the rule, seems to disappear at times, and it is then the sustained analytic setting that ensures through its vicariousness, until such time as a successful interpretation or a working-through makes it reappear, along with the meaning of the play of psychic forces that it represents.

d) The putting into effect of the rule has its optimal relevance when, as is the case in the neurotic, the topography of the repression attests to a tempered conflict between the pleasure principle and the reality principle. Clinical work has brought to light forms of resistance linked to the unconscious of the ego and the superego that subvert the dynamics of the analytic

situation (interminable analysis, or even disorganizing regression). Here we shall mention only the need for punishment, linked to unconscious guilt, that can be appeased only in and through suffering. The dynamic of the rule is perverted when the unpleasure it involves satisfies this need in an overly masochistic way. The work of analysis can then no longer be based on the logic of the pleasure principle to modify this need. This is but one of the many examples that could illustrate the limits of the rule's relevance and the need, in many cases, to situate the analysis outside its bounds.

The discrepancy between the apparent programmatic rationality of the rule and the complexity of its metapsychology explains that both its practical value and the function of its statement have been relativized and indeed called into question. Many analysts believe it is superfluous to state it. Others even deem it antianalytic, because it introduces an alienating representation of a goal, that of speaking "according to" the rule, and they believe it is preferable that the dynamics of the analysis begin spontaneously, allowing the patient to discover its inherent rule when they can make sense of it.

By contrast, one can underscore that the analytic situation could not be established by acting as if the superego-linked register of the prescription could be abolished. In this vein, one can point out that the statement of the rule, in its brilliant economy, condenses that which can be directly transmitted at the outset of the cure, and which the analyst states in the name of the analysis. In this way, it dismisses other, more implicit or more insidious prescriptions, and places the patient in the position of assuming responsibility for his or her own analysis.

The statement of the rule thus takes on the meaning of a repetition of an original, founding statement of the analytic situation. While the rule was initially intended as a third locus excluding suggestion from the analytic process, through its ineluctable transference evolution, it has proved to be the means and the place through which the effects of suggestion can be identified and analyzed in the transference.

JEAN-LUC DONNET

*See also:* Active technique; Face-to-face situation; Free association; Modesty; Obsessional neurosis (compulsive neurosis); *Outline of Psychoanalysis*, An; Psychoanalytic treatment; "Recommendations to Physicians Practising

Psycho-Analysis;” “Remembering, Repeating and Working-Through;” Training analysis; Training of psychoanalysts; Transgression; Truth.

### **Bibliography**

Freud, Sigmund (1904a [1903]). Freud’s psycho-analytic procedure. *SE*, 7, 247–254.

———. (1912e). Recommendations to physicians practising psycho-analysis. *SE*, 12, 109–120.

———. (1913c). On beginning the treatment (Further recommendations on technique of psycho-analysis I). *SE*, 12, 1–144.

———. (1914g). Remembering, repeating and working-through (Further recommendations on the technique of psycho-analysis II). *SE*, 12, 145–156.

---

## **FUSION/DEFUSION**

The concepts of fusion and defusion essentially apply to the life and death instincts, which are initially closely united but later become partially differentiated, under the influence of various psychic movements. Some portion of these instincts remains fused together in the self, in the form of erotogenic masochism (Laplanche and Pontalis, 1967, pp. 244–245).

The elaboration of the second theory of the instincts in “Beyond the Pleasure Principle” (1920g) led Sigmund Freud to postulate the existence of two types of instincts: the life instinct, which forms ever-larger units, and the death instinct, which disintegrates these units. Fusion of the life and death instincts is primal. Outward projection of the death instinct, when it is redirected inward toward the self, constitutes secondary masochism, Freud asserted in “The Economic Problem of Masochism” (1924c). But, according to Freud, a psychic movement that inhibits libidinal satisfaction, such as the movement that is the basis for the existence of the superego or the process of sublimation, by its very nature brings about a defusion of the instincts and thus unleashes destructiveness. This is what endows the Superego with a brutal and cruel aspect, Freud explained in “The Ego and the Id” (1923b).

Benno Rosenberg, in his thorough study of the consequences of this theory of fusion of the instincts, postulated the existence of a form of “life-saving

masochism,” so named because it restrains primal destructiveness in its structures. Nevertheless, there is a remaining ambiguity: When Jean Laplanche in *The Language of Psychoanalysis* (1967, trans. 1974) deemed the term *union* preferable to *fusion*, he introduced the concept of binding (Wilfred R. Bion), which has generally supplanted the concept of fusion in the current psychoanalytic literature. However, the concept of binding/unbinding applies to that which interrelates or separates the ego and the object, and no longer applies to the two types of instincts.

It has come to the point where the term *fusion* is often used instead of *binding*; there is thus a confusion between that which pertains to the integration of opposite qualities, with all the mental work that entails, and what was originally conceived as a primal attribute of the psyche. This confusion particularly affects the concept of ambivalence, which is the maintaining of two distinct qualities that exist in conjunction but not in a state of fusion.

CLÉOPÂTRE ATHANASSIOU-POPESCO

*See also:* Activity/passivity; Binding/unbinding of the instincts; Death instinct (Thanatos); Economic point of view; Eros; Free energy/bound energy; *Ego and the Id, The*; Life instinct (Eros); Love-Hate-Knowledge (L/H/K links); Sexuality.

### **Bibliography**

Freud, Sigmund. (1920). Beyond the pleasure principle. *SE*, 18, 7–64.

———. (1923). The ego and the id. *SE*, 19, 12–66.

———. (1924). The economic problem of masochism. *SE*, 19, 159–70.

Laplanche, Jean, and Pontalis, Jean-Bertrand. (1974). *The language of psycho-analysis*. (Donald Nicholson-Smith, Trans.). New York: Norton.

Rosenberg, Benno. (1991). *Masochisme mortifère et masochisme gardien de la vie*. (pp. 30–54). Paris: Presses Universitaires de France.

---

## **FUSION/DEFUSION OF INSTINCTS**

Freud used the terms “fusion” and “defusion” (*Mischung/Entmischung*), in the context of his second theory

of the instincts, to account for the “mixing” and separation of the life instincts and the death instincts.

Throughout his work, Freud relied upon the notion of an instinctual dualism, on an opposition between two fundamental kinds of instinct, to explain the conflict inherent in mental life. In his first theory of the instincts, he contrasted sexual instincts on the one hand and self-preservative instincts (or ego-instincts) on the other. In his second theory, the life instinct, or Eros, stood opposed to the death instinct, and Freud emphasized that the antagonistic relationship between the two reflected their essential nature. The life instinct, for its part, was a force that strove to unify, and this included unifying the two fundamental instincts themselves; their intimate fusion came about through their simultaneous cathexis of the same object, which rendered them well-nigh indissoluble. At the same time, the death instinct, which promoted dissolution, worked to defuse them through a decathexis of the object, thus threatening the unity of the psyche itself.

These theses were first set forth in *Beyond the Pleasure Principle* (1920g), where Freud, postulating the self-destructive character of the death instinct, sought to show how a portion of its self-destructiveness was immediately neutralized by the life instinct, which eroticized it. In the first edition of the work, in introducing the notion of instinctual fusion, Freud cited Alfred Adler (p. 53n), who had indeed, many years earlier, argued that instinctual energy stemmed from “two originally separate instincts,” the one sexual, the other aggressive, “which had subsequently intersected” (Adler, 1908). Freud would observe later, in “Analysis Terminable and Interminable” (1937c), that “The two fundamental principles of Empedocles—love and strife—are, both in name and function, the same as our two primal instincts” (p. 246).

With *The Ego and the Id* (1923b), the fusion and defusion of instincts became a feature of Freud’s second topography (also known as the structural theory): defusion was now viewed as a function of the id and of the severity of the superego, while fusion was the task of the ego, both constitutionally and in its role as unifier of the three mental agencies. Instinctual defusion caused regression, and identification and sublimation themselves tended to bring about defusion. The clinical prototype of instinctual fusion was to be found in the action of sadism (which facilitated the turning of the death instinct toward the external world) and of masochism; its metapsychological prototype was

primary erotogenic masochism. The physiological basis of this last, namely sympathetic sexual excitation, constituted the very foundation of the Freudian theory: “It may well be that nothing of considerable importance can occur in the organism without contributing some component to the excitation of the sexual instinct” (1905d, p. 205; 1924c, p. 163).

The fusion and defusion of the instincts (*Triebmischung/Triebentmischung*) needs to be clearly distinguished from the processes known as binding and unbinding (*Bindung/Entbindung*). Freud first used these last terms in connection with energy flows: the self-preservative instincts of the ego, he argued, tended to bind the free energy that flowed continuously from the sexual instincts; unbinding, therefore, was a discharge of free energy by the ego. In 1920, when Freud advanced the notion that union was the aim of the life instincts, he saw such union as dependent for its quality and its strength on this internal capacity of the ego’s to bind self-preservative impulses to free sexual energy (Rosenberg, 1991). The best way to keep the distinction clear between the two above-described levels of instinctual interaction—the binding/unbinding processes internal to the ego and the fusion/defusion of the life and death instincts—is to confine the original economic reading to binding/unbinding. Variations in the quantitative factor may then be said to bring about a qualitative modification of the instinctual fusion, notably in “the advance from the earlier [genital] phase to the definitive genital one” (1923b, p. 42).

Attention to the variations of the binding/unbinding internal to the ego and the fusion/defusion of the life and death instincts has played a heuristic role in the understanding of psychosis (in the work of Melanie Klein, Piera Aulagnier, Benno Rosenberg, and others), of psychosomatic illness (for Pierre Marty), and of borderline conditions (in the “objectalizing/ deobjectalizing function” described by André Green).

Jacques Lacan has criticized an approach that casts a positive light on instinctual binding and its agency, the ego, while condemning the fascinating and immobilizing aspects of the process. Jean Laplanche (1981) has for his part argued that sexuality should not be reduced to the unifying function of the life instinct lest it thereby be divested of its non-bound aspect, with its fundamentally destructive and even demoniacal features.

JOSETTE FRAPPIER

See also: Binding/unbinding of the instincts.

### Bibliography

- Adler, Alfred. (1908). Der Aggressionstrieb im Leben und in der Neurose. *Fortschrift. Med.*, 26.
- Freud, Sigmund. (1905d). Three essays on the theory of sexuality. *SE*, 7: 123–243.
- . (1920g). Beyond the pleasure principle. *SE*, 18: 1–64.
- . (1923b). The ego and the id. *SE*, 19: 1–66.
- . (1924c). The economic problem of masochism. *SE*, 19: 155–170.
- . (1937c). Analysis terminable and interminable. *SE*, 23: 209–253.
- Laplanche, Jean. (1981). *Problématiques IV. L'Inconscient et le Ça*. Paris: Presses Universitaires de France.
- Rosenberg, Benno. (1991). *Masochisme mortifère et masochisme gardien de la vie*. Paris: Presses Universitaires de France.

---

## FUTURE OF AN ILLUSION, THE

The publication of a *The Future of an Illusion* followed *The Question of Lay Analysis* (1926e) and preceded *Civilization and its Discontents* (1930a [1929]). *Die Zukunft einer Illusion* soon reached a wide audience, and was translated into English in 1928 by W. D. Robson-Scott as *The Future of an Illusion*, and into French in 1932 by Marie Bonaparte as *L'Avenir d'une illusion*.

In a letter to the Swiss Calvinist pastor Oskar Pfister (November 25, 1928), Freud wrote: “I do not know if you have detected the secret link between *Lay Analysis* and the *Illusion*. In the former I wish to protect analysis from the doctors and in the latter from the priests.” Freud keeps his distance from the two principal custodians of secrets protected by the law. Moreover, he considers priestly knowledge, or religious dogma, a “neurotic relic” that it is time to replace “with the results of rational mental labor.”

The link between *The Future of an Illusion* and *Civilization and its Discontents* was made by Romain Rolland. *Liluli*, the title of a play he wrote, was a play on the word “illusion.” In *The Future of an Illusion* Freud discusses the religious feelings then so essential

to Rolland’s thinking and which Freud refers to as “oceanic sensations”; these he considers both eternal and infinite. In *Civilization and its Discontents* Freud explicitly refers to this concept to differentiate himself from it: “I cannot discover this ‘oceanic’ feeling in myself.”

Freud considered religion to be a phenomenon of culture or civilization, based, like all culture, on the “rejection of instincts” by means of “prohibitions.” The gods retain “their threefold task: they must exorcize the terrors of nature,” (especially death), “they must reconcile man to the cruelty of fate, particularly as is shown in death, and they must compensate them for the sufferings and privations which a civilized life in common has imposed on them.” Religion thus constitutes a “treasure of ideas born of the need to make human misery supportable.”

Freud used as an example one of the phases of religious evolution, “which roughly corresponds to the final form taken by our present-day, white, Christian civilization.” Here he makes a clean break with Jung, who based many of his ideas on the religions of India (Hinduism and Buddhism primarily). Logically, he insists on an essential characteristic of Christian religion, “the father-son relationship.” He asserts that “God is an exalted father, the nostalgia for the father is the root of religious need.”

The entire work is marked by Freud’s desire to placate his friend, Pastor Pfister, who responded the following year with the publication of a pamphlet titled *The Illusion of a Future* (1928). Freud distinguished illusion from error: an illusion, the product of desire, is not necessarily false. Moreover, he adds a condition to a claim present in his article on “Compulsive activities and religious exercise” (1907b): “Religion could thus be the universal obsessional neurosis of humanity.” He even considers that “devout believers are safeguarded in a high degree against the risk of certain neurotic illnesses; their acceptance of the universal neurosis spares them the task of constructing a personal one.”

Freud, who spent his life trying to destroy illusions and complete what Max Weber called the “disenchantment of the world,” seems to hesitate when it comes to the future of religious phenomena. He says

he is in favor of “retaining the religious doctrinal system as the basis of education and of man’s communal life.” Just as Charles Maurras at the time defended Catholicism as an element of political order in spite of his naturalist positivism, Freud, in spite of his atheism, defended Christian education (the teaching of religion was required in Austrian schools) “which is so important for the safeguarding of civilization.”

He concludes his work with a case study of conversion, without confusing the beliefs of “inert and unintelligent” crowds with the more certain achievements of science. “No, our science is not an illusion.”

ODON VALLET

*See also:* Belief; *Civilization and its Discontents*; Ethics; *Group Psychology and the Analysis of the Ego*; Magical thinking; Mysticism; Pfister, Oskar Robert; Religion and psychoanalysis; Rite and ritual; Science and psychoanalysis; Weltanschauung.

### Source citation

Freud, Sigmund. (1927c). *Die Zukunft einer Illusion*. Vienna; *GW*, XIV, p. 325–380; *SE*, 21: 5–56.

### Bibliography

Freud, Sigmund. (1907b). Compulsive activities and the exercise of religion. *SE*, 9: 117–127.

———. (1921c). Group psychology and the analysis of the ego. *SE*, 18: 65–143.

———. (1926e). The question of lay analysis. *SE*, 20: 177–250.

———. (1927c). The future of an illusion. *SE*, 21: 1–56.

———. (1930a). Civilization and its discontents. *SE*, 21: 57–145.

Freud, Sigmund and Pfister, Oskar. (1963). *Psycho-analysis and faith; the letters of Sigmund Freud and Oskar Pfister*. (Heinrich Meng and Ernst L. Freud, Eds., and Eric Mosbacher, Trans.). London: Hogarth Press.

Pfister, Oskar. (1928). The illusion of a future. *International Journal of Psycho-Analysis*, 74, 1993, 557–579.





### GADDINI, EUGENIO (1916–1985)

Eugenio Gaddini, president of the Italian Psychoanalytic Society from 1978 to 1982, was born in Cerignola, Foggia, Italy, on January 18, 1916, and died in Rome on September 27, 1985. A brilliant student, he developed a precocious interest in literature and philosophy. In 1942 he received his medical diploma. In 1956 he gave up his position as chief physician in a hospital in Rome to devote himself to psychoanalysis.

After completing an analysis with Emilio Servadio, he was admitted in 1953 to the Società Psicoanalitica Italiana (Italian Psychoanalytic Society), in which he served as secretary (1957), vice president (1967–1969), and president (1978–1982). During his tenure as president, he worked hard to expand the society, primarily by revitalizing the *Rivista de psicoanalisi* (Review of psychoanalysis), of which he was editor for several years. After 1970 he worked as a teacher at the Centro Psicoanalitico Romano (Rome Psychoanalytic Center) and the Centro di Firenze (Florence Center), which he founded, surrounding himself with a circle of students who were receptive to his original ideas. Gaddini was highly esteemed within the International Psychoanalytical Association, where he assumed several high-level positions, and was known for his original contributions in the fields of metapsychology and clinical therapy.

Combining Freudian psychoanalysis with the techniques of Donald Winnicott, he formulated an innovative theory of early mental states, postulating the existence of a “fundamental mental organization,” which serves as the basis for the formation of the self. According to Gaddini, “nonintegration anxiety” occurs during the transition from the “psychosensory zone,” characterized by a preponderance of physical

sensations, to the “psycho-oral zone” (1987). During this process, when the basic outlines of mental structure are laid down, the mechanism of imitation plays an important role (Gaddini, 1969). Gaddini distinguished imitation from introjection and identification, which he associated with the psycho-oral zone, where the tension to “attain the object” was a sign of distinctness and separation. Imitation he associated with the psychosensory zone and “correlative bodily fantasies.” In other words, fantasies of fusion respond to bodily changes associated with becoming “the object.” During the course of analysis (1981), disturbances of the psychosensory zone become manifest in transference through the patient’s use of mechanisms of imitation to reestablish fusion, as if by magic, and avoid recognition of the object as an other distinct from the self.

In his writing, Gaddini suggested reconsidering the function of the father in the oedipal triangle (1989) and in aggression. Adopting the fusion theory of instincts, he hypothesized that aggression shifted the libido from its initial narcissistic position to objects (1972). His essay “Transitional objects and the process of individuation,” published in 1970 with his wife Renata, continued the work of Donald Winnicott. Gaddini’s writings have been collected in *Scritti*, published posthumously in 1989 and translated into English in 1992.

ANNA MARIA ACCERBONI

*See also:* Italy

#### **Bibliography**

Gaddini, Eugenio. (1969). On imitation. *International Journal of Psycho-analysis*, 50, 475–484.

- . (1972). Aggression and the pleasure principle: Towards a psychoanalytic theory of aggression. *International Journal of Psychoanalysis*, 53 (2), 191–198.
- . (1987). Notes on the mind-body question. *International Journal of Psychoanalysis*, 68 (3), 315–330.
- . (1989). *Scritti*. Milan, Italy: Raffaello Cortina.
- . (1992). *A psychoanalytic theory of infantile experience: Conceptual and clinical reflections* (Adam Limentani, Ed.). London: Tavistock Publications.
- Limentani, Adam. (1986). Eugenio Gaddini (1916–1985). *International Journal of Psycho-analysis*, 67, 373–374.

## GAIN (PRIMARY AND SECONDARY)

Primary and secondary gains correspond to the direct or indirect advantages that individuals gain from their illness. The primary gain is a constitutive element of the illness that is present in the very motive of the illness. The secondary gain is an addition to the primary gain and comes into play at a later stage. It consolidates the disorder.

The specific term “gain” in relation to an illness appeared in 1897 in a letter from Freud to Wilhelm Fleiss. Secondary gain is described for the first time in 1913 in *On Beginning the Treatment*: here the symptom has a secondary function (1913c). In 1916 in Lecture twenty-four of *Introductory Lectures on Psychoanalysis* Freud clearly articulated the distinction between primary and secondary gain (1916–17a, [1915–17]), and again in 1923 in a footnote to the study of the case of Dora (1905e [1901]).

Primary gain subdivides into two parallel aspects. In the internal part, illness remains the most economic solution in cases of conflict, and this is the “flight into illness.” The external part is linked to profitable arrangements occasioned in the individual’s relational life. The secondary gain “helps the ego in its effort to incorporate the symptom.” (1916–17a [1915–17]) It procures a satisfaction that is narcissistic or linked to self-preservation.

DOMINIQUE BLIN

*See also:* Flight into illness; Narcissism

### Bibliography

- Freud, Sigmund. (1905e [1901]). Fragment of an analysis of a case of hysteria. *SE*, 7: 1–122.

- . (1916–17a [1915–17]). Introductory lectures on psycho-analysis. Parts I and II. *SE*, Part I, 15 ; Part II, 16.
- . (1923b). The ego and the id. *SE*, 19 : 1–66.
- . (1926e). The question of lay analysis. *SE*, 20: 177–250.

## GARDINER, MURIEL (1901–1985)

An American psychoanalyst and psychiatrist, Muriel Gardiner was born November 23, 1901 in Chicago, Illinois and died February 6, 1985 in Princeton, New Jersey.

The daughter of Edward Morris and Helen Swift, she was born into a family of wealth and privilege. During her childhood she became aware of the plight of the poor and disenfranchised and subsequently developed a life-long commitment to social and political reform. After graduating from Wellesley College in 1922 she traveled to Europe where she lived until the outbreak of World War II.

In 1926 she settled in Vienna where she underwent the first of two periods of analysis with Ruth Mack Brunswick. During this period she developed an interest in applying psychoanalytic insights to education. Simultaneously with her psychoanalytic training she attended the Vienna Medical School, graduating in 1938. In 1934, in the midst of her training and a second period of analysis with Mack Brunswick, a fascist dictatorship was installed in Austria. Witnessing the brutality that accompanied these events was a turning point in Gardiner’s life. She resolved to help endangered individuals escape from fascist Europe, and for the next six years worked tirelessly in the Austrian underground. These years are vividly described in her memoir *Code Name “Mary”* (1983).

After returning to the United States in 1939 Gardiner completed her analytic training at the Philadelphia Association for Psychoanalysis, with which she was associated for many years. Gardiner was appointed a training and a supervising analyst in 1955, but she never accepted any candidates. Rather she found fulfillment by using her training in psychoanalysis in her work as a consultant in schools, hospitals, and residential settings. Here she was able to offer help to children and adolescents, and to their teachers, social workers, and doctors.

Gardiner’s publications include *The Deadly Innocents: Portraits of Children Who Kill* (1976), a book which grew out of her work with children and adolescents; and

*The Wolf-Man by the Wolf-Man* (1971), which she edited. This is a compilation which includes his autobiographical reminiscences, Freud's original case report, Ruth Mack Brunswick's 1928 essay, and Gardiner's paper recording her contacts with the Wolf Man over three decades. After the Wolf Man's death in 1979 she wrote *The Wolf Man's Last Years* (1983a) wherein she described his final years and gently but pointedly took issue with Karin Obholzer's portrayal of the Wolf Man in her 1982 book, *The Wolf Man, 60 Years Later*.

Muriel Gardiner's contribution to psychoanalysis goes beyond her books and papers, her generous support of the Hampstead Clinic, the Freud Archives, and the Freud Museum, and her long relationship with the Wolf Man, characterized as it was by her concern for his dignity and psychological well-being. Of equal significance was the fact that she took psychoanalytic insights and her counsel into settings—schools, hospitals, and prisons—where they are usually not found.

NELLIE L. THOMPSON

See also: Brunswick, Ruth Mack; Freud Museum; "From the History of an Infantile Neurosis" (Wolf Man); Panjeff, Sergej.

### **Bibliography**

- Gardiner, Muriel M. (1971). *The Wolf-Man by the Wolf-Man*. New York: Basic Books.
- . (1976). *The deadly innocents: Portraits of children who kill*. New York: Basic Books.
- . (1983). *Code name "Mary": Memoirs of an American woman in the Austrian underground*. New Haven and London: Yale University Press.
- . (1983a). The Wolf Man's last years. *Journal of the American Psychoanalytic Association*, 31, 867–897.
- Guttman, Samuel A. (1985). *In memoriam Muriel M. Gardiner, M.D. (1901–85). The Psychoanalytic Study of the Child*, 40, 1–7.

## **GARMA, ANGEL (1904–1993)**

A Spanish psychiatrist and psychoanalyst, Angel Garma was born June 24, 1904, in Bilbao, and died January 29, 1993, in Buenos Aires.

Garma, a Basque by birth and temperament, went to Madrid at the age of seventeen to study medicine.

After completing his studies he left for Germany, where he was a student of Robert Gaupp and Karl Bonhoeffer. In 1929 he began a training analysis with Theodor Reik at the Berlin Institute of Psychoanalysis.

When he was twenty-seven Garma became a member of the Berlin Psychoanalytic Association (BPV) after presenting his now classic paper, "Die Realität und das Es in der Schizophrenie" (Reality and the Id in Schizophrenia), which he read in October 1931. This innovative essay questions the Freudian conception of psychosis. While Freud believed the psychotic repressed reality to satisfy the id, Garma claimed that the psychotic represses the id more than the neurotic, which disturbs his relation to reality.

At the end of 1931 Garma settled in Madrid. Although he had completed his training with the Berlin Psychoanalytic Association, he soon quit the organization, decrying its growing discrimination. He remained a "direct member" of the International Psychoanalytic Association (IPA) for several years. In July 1936, before the start of the Spanish Civil War and in spite of his sympathy for the Republicans, Garma went to France to avoid the fratricidal struggle taking place in his homeland. Through the Société Psychanalytique de Paris he met Celes Ernesto Cárcamo, an Argentinean who had trained in Europe before returning to Buenos Aires. He invited Garma to accompany him. Garma preferred to remain in Paris, but spurred on by the impending world war, he eventually decided to leave.

Garma arrived in Argentina in June 1938 and quickly adapted to life in Buenos Aires, a progressive city where psychoanalysis was already being taught. Cárcamo's return in 1939 gave a new impetus to the nascent psychoanalytic movement, which was soon reinforced by the arrival of Marie Langer.

In late 1942 the Asociación Psicoanalítica Argentina (APA) was founded. Garma was its first president (1942–1944), a position he held on three other occasions during his life. He founded the Institute for Psychoanalysis, where he was a teacher for thirty-two years. During his tenure as APA president, Garma promoted scientific activity, established annual conferences, and helped organize Latin-American and Pan-American conferences.

Garma's work was widely recognized during his lifetime. He was honored publicly on his seventieth birthday and, in 1983, was named honorary vice

president of the IPA. In 1989 King Juan Carlos I of Spain decorated him and the APA named the Institute of Psychoanalysis after him. A year later he was elected honorary president of the Psychoanalytic Federation of Latin America (FEPAL).

An important pioneer, Garma developed a body of scientific work of considerable importance. He made significant contributions to the study of the psychoanalysis of dreams, psychoses, perversions, psychosomatic medicine, and technique. Within his extensive body of work his detailed and careful work on gastric ulcers and headache deserve special mention.

Dream-like phenomena were a constant preoccupation for Garma. The doctoral dissertation he presented in Argentina, “Psicoanálisis de los sueños” (1940, [Psychoanalysis of Dreams]) became a classic. Garma continued to make contributions to the theory of dreams, focusing his work on the *Traumdeutung*, even though he sometimes disagreed with Freud’s findings.

Garma’s research primarily involved the theory of the traumatic genesis of dreams, the characteristics of dream-like thought, the origin of dream hallucinations, and the relation to reality. The dream originates in unconscious conflicts that configure a traumatic situation, so that, ultimately, all dreams are nightmares. The satisfaction of desire is merely an attempt to mask the traumatic situation. The dream work is not limited to providing mental content with a new form, it is a creative process, a particular type of thought, archaic and vast. Garma’s theory on the origin of dream hallucination and the relation to reality, which contradicts Freud, is discussed in his essay “La realidad exterior y los instintos en la esquizofrenia” (External Reality and the Instincts in Schizophrenia), published in 1931. Here, the relation of the subject to reality is disturbed whenever he has to abandon the satisfaction of impulsive demands and submit to internal persecutory objects that channel the death impulse.

These ideas, along with others, are crystallized in two important books. *Nuevas Aportaciones al psicoanálisis de los sueños* (1970, [New Contributions to the Psychoanalysis of Dreams]) covers thirty years of his work, although it by no means exhausts his contributions to the field. His *Tratado mayor del psicoanálisis de los sueños* (1990, [Comprehensive Treaty on the Psychoanalysis of Dreams]) incorporates the work done during the last twenty years of his life. All of Garma’s work is a sustained and consistent effort to unmask a

fundamental structural conflict, the submission of a masochistic ego to a sadistic superego that serves as an obstacle to the free exercise of genitality.

Angel Garma had two daughters, Lucinda and Isabel, with Simone Mas, his first wife. Elisabeth Goode Rasmussen, his second wife, who was with him at the height of his career, remained a steadfast caretaker during the years of his illness. An eminent psychoanalyst in her own right, she assumed the difficult role of being the wife of a great man. Angel and Elisabeth had two daughters, Carmen and Sylvia.

R. HORACIO ETCHEGOYEN

*See also:* Argentina; Colombia; Congrès des psychanalystes de langue française des pays romans; Federación psicoanalítica de América latina; Spain.

### Bibliography

- Garma, Angel. (1931). Die Realität und das Es in der Schizophrenie. *Internationale Zeitschrift für Psychoanalyse*.
- . (1970). *Nuevas aportaciones al psicoanálisis de los sueños*. Buenos Aires: Paidós.
- . (1985). *The psychoanalysis of dreams*. New York: Jason Aronson. (Original work published 1940)
- . (1990). *Tratado mayor del psicoanálisis de los sueños*. Madrid: Contenido.

---

## GATTEL, FELIX (1870–1904)

Felix Gattel, a medical doctor, was born in Berlin on December 14, 1870, and died in 1904. He is known in the history of psychoanalysis as Sigmund Freud’s first student.

Gattel traveled from San Francisco to Würzburg, Germany, to complete his studies. Though he specialized in neurology, he spent May to October 1897 in Vienna, studying with Freud (Masson, Jeffrey M., 1985). He published a few articles but after 1899 all trace of Gattel was lost. The exact date of his death is not known, but Wilhelm Fliess indicates in his writings that he died in 1906. Subsequent research by Michael Schröter and Ludger M. Hermanns has led to the conclusion that he died on October 17, 1904.

Gattel followed the same initial scientific education as Freud, beginning his career in pathological anatomy. His interest then turned to neurosis and sexuality. He

learned about Freud while he was doing research, in particular, through an article written by Freud in collaboration with Oskar Rie on infantile cerebral hemiplegia (1891a). Gattel, aware of Freud's growing reputation in the field of neurasthenia and hysteria, contacted him before settling in Vienna, most likely to take advantage of Freud's clinical experience.

Gattel remains something of a mystery to us, since there is little available biographical material. He was one of Freud's earliest supporters and, with Emma Eckstein, can be considered one of his first students—at least in the traditional academic sense, where a young medical student might work under the guidance of an older colleague. Eckstein can be considered the first student of analysis, since she was analyzed by Freud and then began analyzing others in turn.

Gattel's importance—although minor—in the history of psychoanalysis shows up in several ways. Freud, eager to communicate his research results, conducted experiments with him, as he did later with Heinrich Gomperz; this was classic scientific research as practiced in academic circles. As an academic Freud assigned Gattel the job of conducting field research in neurasthenia (letter to Wilhelm Fliess, January 20, 1898). Gattel was an enthusiastic and enterprising student, but not up to the theoretical level his teacher would have liked. It was through these early experiments with Gattel that Freud came to understand that conventional scientific research was not the best method for communicating his ideas. During this work, he came to understand the importance of transference between student and teacher. It is easy to understand the importance of Freud's first students by examining the concept of the correspondent in scientific discovery. Gattel and Fliess, although in different ways, assumed this role before the creation of the Wednesday Psychological Society. It was during these meetings that Freud was able to express himself most fully, for his audience was able to follow his ideas and spurred him on intellectually. At the same time, given the inevitable diffusion of transference in a small group, he was not overly concerned with the intensity of two-way transference. This activity preceded the evolution of the small group of the "savage horde" that Freud later became interested in.

Gattel appears in the Freud-Fliess correspondence as someone inclined to plagiarism. He was the quintessential mediocre student. In the Swoboda affair, which

signaled the end of Freud's friendship with Fliess (Porge, Erik, 1994; Le Rider, Jacques, 1982), he is mentioned as an example of an unreliable personality. Frank J. Sulloway (1979) exaggerates his importance, but Schröter and Hermanns (1992) provide a more accurate assessment of him as a talented and hard working young man, capable of recognizing the value of a scientific discovery but unable, during his short life, to live up to the promise of his talent.

NICOLAS GOUGOULIS

See also: Germany; "Neurasthenia and 'Anxiety Neurosis'".

### **Bibliography**

- Freud, Sigmund, and Rie, Oskar. (1891a). *Klinische Studie über die halbseitige Cerebrallähmung der Kinder*, Heft III der Beiträge zur Kinderheilkunde. Wien: Kassowitz.
- Le Rider, Jacques. (1982). *L'Affaire Otto Weininger*. Paris: Presses Universitaires de France.
- Masson, Jeffrey M. (1985). *The complete letters of Sigmund Freud to Wilhelm Fliess 1887–1904*. London: Belknap.
- Porge, Erik. (1994). *Vol d'idées?* Paris: Denoël.
- Schröter, Michael and Hermanns, Ludger. (1992). Felix Gattel, 1870–1904: Freud's first pupil. *International Review of Psychoanalysis*, 19, 91–104, 97–208.
- Sulloway, Frank J. (1979). *Freud—biologist of the mind*. London: Burnett.

---

### **GELEERD, ELISABETH (1909–1969)**

Psychoanalyst Elisabeth Geleerd was born on March 20, 1909 in Rotterdam, the Netherlands, and died May 25, 1969 in New York.

Elisabeth Geleerd's parents were Moses and Bertha (Haas) Geleerd. The eldest of three children, she and her two younger brothers, Yap and Benedictus, grew up in comfortable circumstances in Rotterdam where her father's business was outfitting ships. When she was nine or ten her mother died of tuberculosis and she was sent to live with an aunt and uncle. This was an unhappy experience and she returned to her father's house in her early teens. Several years later Yap also died of tuberculosis. The deaths of her mother and brother influenced Elisabeth's decision to study medicine at the University of Leyden. Her father supported her ambition to become a physician.

After receiving her M.D. in 1936, she moved to Vienna in order to undertake psychoanalytic training at the Vienna Psychoanalytic Institute, where her analyst was Anna Freud. In 1938 the deteriorating political situation led her to move to London, where she completed her analytic training at the Institute for Psychoanalysis, the training arm of the British Psychoanalytic Society. In 1940 she arrived in the United States and worked for several years at the Menninger Clinic in Topeka, Kansas before finally settling in New York in 1946. That same year she married the prominent psychoanalyst, Rudolph M. Loewenstein.

In 1947 Geleerd was appointed a training analyst at the New York Psychoanalytic Institute and, as a member of the Educational Committee, played a formative role in the development of the Child and Adolescent analysis program at the Institute.

Recollections of Geleerd invariably note her intelligence and beauty. Her countenance has been described as neoclassical and delicate, her temperament as sensitive, searching and romantic. The congruence between her face and her character, each mirroring the other, left an indelible impression on her friends and colleagues. She was by all accounts an empathic therapist, but her approach to patients was based on a thorough grasp of psychoanalytic theory and technique. In a series of papers on the psychodynamics of childhood schizophrenia, the developmental vicissitudes of adolescence and the psychological states of fugue and amnesia, she delineated the defenses the ego utilizes in its attempt to master early, often overwhelming trauma originating in the mother-child relationship. She also sought to suggest new techniques for treating seriously disturbed children and adolescents.

NELLIE L. THOMPSON

*See also:* Loewenstein, Rudolph M.

### **Bibliography**

Geleerd, Elisabeth R. (1958). Borderline states in childhood and adolescence. *The Psychoanalytic Study of the Child*, 13, 279–295.

———. (1964). Child analysis: Research, treatment and prophylaxis. *Journal of the American Psychoanalytic Association*, 44, 242–258.

Kabcenell, Robert. (1970). Eulogy for Elisabeth Geleerd. Unpublished. A.A. Brill Library, the New York Psychoanalytic Institute.

Tartakoff, Helen. (1970). Obituary Elisabeth Geleerd Loewenstein. *International Journal of Psychoanalysis*, 51, 71–73.

Thompson, Nellie L. (1997). Elisabeth Geleerd. In *Jewish women in America: An historical encyclopedia*, Volume One. (pp. 501–502) (Paula E. Hyman and Deborah Dash Moore, Eds.) New York: Routledge.

---

## **GENDER IDENTITY**

The term *gender identity*, meaning a person's relative sense of his or her own masculine or feminine identity, was first used in 1965 by John Money (Money, 1965). The term was introduced into the psychoanalytic literature by Robert Stoller in 1968 (Stoller, 1968).

Money used the term to distinguish the subjective experience of gender from the concept of “gender role” which he used to describe the socially determined attributes of gender.

Stoller (1968) developed the idea further to distinguish between the psychological and biological dimensions of sex. He used *gender* to distinguish ideas and experiences of masculinity and femininity—both socially determined psychological constructs—from *sex*, the biologically determined traits of maleness and femaleness. This usage has become the standard in psychoanalytically derived discussions of gender and sexuality to refer to the psychological aspects of sexuality, what Freud (1925) called “psychical consequences of the anatomical distinction between the sexes.”

Stoller (1968) further distinguishes the general sense of masculinity and femininity—*gender identity*—from the earlier awareness of sexual difference, what he calls *core gender identity*, a relatively fixed sense of maleness or femaleness usually consolidated by the second year of life, prior to the oedipal phase.

Stoller identifies three components in the formation of core gender identity: 1) Biological and hormonal influences; 2) Sex assignment at birth; 3) Environmental and psychological influences with effects similar to imprinting.

In contrast to Freud's belief that the primary identification is masculine, Stoller believes that both the boy and the girl begin with a female core gender identity obtained from the maternal symbiosis. Core gender identity is derived non-conflictually through identification and, in essence, learning. Failure to interrupt the maternal symbiosis pre-oedipally with boys may

result in permanent core gender identity disorders like transsexualism. Otherwise, normal development facilitates the boy's shift to a male core gender identity and the subsequent oedipal conflicts associated with obtaining a masculine gender identity.

The concept of gender identity is important historically because it separates masculine and feminine psychology from the innate biological determinism suggested by Freud. Increasing attention to the diversity and multiplicity of the origins and workings of gender have made even the terms gender identity and core gender identity less than adequate to describe the nuances of such a central organizing factor of personality and behavior. It is important to differentiate the term, gender identity, which describes the individual's sense of gender, from Stoller's speculative theory about the origins of core gender identity.

CHRISTOPHER GELBER

*See also:* Femininity; Feminism and psychoanalysis; Identity; Imaginary identification/symbolic identification; Masculinity/femininity; Perversion; Sexual differences; Stoller, Robert J.; Transsexualism.

### **Bibliography**

- Freud, Sigmund. (1925j). Some psychical consequences of the anatomical distinction between the sexes, *SE*, 19: 241–258.
- Money, John (Ed.). (1965). *Sex research: New developments*. New York: Holt, Rinehart and Winston.
- Stoller, Robert. (1968). *Sex and gender: On the development of masculinity and femininity*. New York: Science House.

### **Further Reading**

- Benjamin, Jessica. (1998). *Shadow of the other. Intersubjectivity and gender in psychoanalysis*. New York: Routledge.
- Breen, Dana. (Ed.). (1993). *The gender conundrum*. London, New York: Routledge
- Chodorow, Nancy. (1978). *The reproduction of mothering. Psychoanalysis and the sociology of gender*. Berkeley: University of California Press.
- Fast, Irene. (1999). Aspects of core gender identity. *Psychoanalytic Dialogues*, 9, 633–662.
- Stoller, Robert. (1985). *Presentations of gender*. New Haven, London: Yale University Press.
- Wagonfeld, S., rep. (1982). Panel: Gender and gender role. *Journal of the American Psychoanalytic Association*, 30, 185–196.

## **GENERAL MEDICAL SOCIETY FOR PSYCHOTHERAPY (AÄGP).** *See* *Allgemeine Ärztliche Gesellschaft für Psychotherapie*

## **GENERAL THEORY OF SEDUCTION**

Sigmund Freud developed the theory of seduction in the years 1895–1897, and then he abandoned it. The theory accounted for the genesis of the psychopathological unconscious on the basis of a complex mechanism that brought two moments into play: a scene in which a child is seduced by an adult, and the “deferred” reactivation of this scene at a later time.

Jean Laplanche has proposed a “general theory of seduction,” extending the Freudian seduction theory to the genesis of the unconscious in general, and broadening its foundations to include primacy of the other's enigmatic message and the theory of repression as a partial failure to translate this message.

It has been said, and is incessantly repeated, that Freud abandoned his first theory of the neuroses and announced this to Wilhelm Fliess in his letter dated September 21, 1897 (*SE* 1, p. 259). Recrudescences and relics of this theory are nonetheless legion in Freud's work. What is perhaps the most surprising fact is that it was effectively tabooed and misrepresented until 1964 (Laplanche and Pontalis, 1964). Even then, when it began to attract a new interest, this was directed not to the highly complex mechanism described by Freud but instead to anecdotes of manifest sexual abuses and to the issue of whether Freud had fled, or “repressed,” this reality and taken refuge in the hypothesis of a pure and simple production of fantasies (Masson, 1984).

Freud's original seduction theory was strictly confined to the realm of the psychoneuroses. It is even tempting to think that Freud posited the existence of the unconscious in neurotics alone, and that he nourished the hope that cure might come to mean the elimination of the unconscious.

The theory sought to explain the development of the unconscious by the repression, in the child, of memories of sexual scenes usually experienced while in the charge of an adult. It brought three interconnected levels into play: a temporal dimension, a topographical dimension, and a language-related dimension. The temporal aspect of seduction was



bound up with the concept of deferred action (or “afterwardness” [Nachträglichkeit]), which was to survive in Freud’s later thought. The thesis was that nothing was inscribed in the human unconscious save by way of the interrelationship between at least two events separated from one another by a period of mutation, a lapse of time that made it possible for the subject to react differently to the memory of the first experience than to the actual experience as lived. Left in suspense, the initial memory became pathogenic and traumatizing when revived by the occurrence of a second scene having some association or resonance with the first.

The topographical aspect involved the theory of an ego in the process of formation, armored against attack from without but not against attack from within. Since what attacked it at the second moment was not an outside event but a memory, this ego was unprotected and could react only by repression.

Lastly, a linguistic aspect of the theory was suggested by Freud’s analogy between the barrier separating the two moments of the psychical trauma and a translation, or a partial failure of translation (letter to Fliess of December 6, 1896, *SE* 1, p. 235).

It is thus apparent just how inadequate a response it is to reduce the seduction theory to the simplistic assertion that the adult’s seduction of the child brings on mental disturbance. Freud’s first theory was in fact intimately interwoven with the clinical doctrine of the time.

At the close of 1897, Freud undertook a systematic critique of his theory which led him to abandon it, surrendering hysterics to their “seduction fantasies,” and those fantasies themselves, ultimately, to a phylogenetic determinism.

The critique of a theory—its “falsification”—may have several outcomes: rejection, partial modification, or a reexamination of its foundations. It is the last of these that Jean Laplanche has sought with his “general theory of seduction.” In the first place, he argues, the unconscious should not be looked upon as invariably pathological. The unconscious is part of the human condition, and there is therefore no reason to rebuke a theory or a practice for not being able to eliminate it. Secondly, the adult-child relationship ought to be viewed in a way that transcends psychopathological features specific to particular cases of perverse sexual abuse. Generally speaking, there is a basic asymmetry between the infant and the adult, stemming from the

fact that adults have already constructed a sexual unconscious for themselves and that their way of addressing themselves to children, in gestures or words, is necessarily shot through by that unconscious. Thirdly, the general theory of seduction aims to bring considerations to the fore that played little part in Freud’s thinking. These include: the notion of the message; the priority of the adult other in the message received by the infant; and, lastly, the idea of “translation” as the basis for a model of repression less mechanistic than that of a pure interplay of forces, as set forth in classical psychoanalytic thought.

JEAN LAPLANCHE

*See also:* Anaclisis/anaclitic; Breastfeeding; Deferred action and trauma; Heterosexuality; Masochism; Maternal reverie, capacity for; Object; Ontogenesis; Oral stage; Proton-pseudos; Seduction; Seduction Scenes.

### **Bibliography**

- Freud, Sigmund. (1896c). The aetiology of hysteria. *SE*, 3: 186–221.
- . (1950a [1887–1902]). Extracts from the Fliess papers. *SE*, 1: 173–280.
- Laplanche, Jean. (1989 [1987]). *New foundations for psychoanalysis*. (David Macey, Trans.). Oxford: Blackwell.
- Laplanche, Jean, and Pontalis, Jean-Bertrand. (1968 [1964]). Fantasy and the origins of sexuality. *International Journal of Psycho-Analysis*, 49, 1–18.
- Masson, Jeffrey Moussaieff. (1984). *The assault on truth*. New York: Farrar, Straus and Giroux.

---

**GENEVA PSYCHOANALYTICAL SOCIETY.** *See* Société psychanalytique de Genève

---

### **GENITAL LOVE**

*Genital love* corresponds to the type of object relation organized during the adult genital phase of libidinal development. It is characterized by the unification, under the primacy of the genital, of pregenital sexual aims and, in particular, by the reunion of the two currents of sexuality—sensuality and affection.

It is difficult to provide a univocal definition of love. The Greeks differentiated among *eros*, *philia*, and *agapè*,

distinctions that were picked up by Freud, who distinguished sensual love from affection and from love in the more general sense of the term. Although he leaves discussions of love to the poets, Freud refers to the polysemy of the term “love,” which he judges to be well founded: sexual and amorous relations between men and women, love between parents and children, friendship, self-love, the love of truth or humanity. “We are of the opinion, then, that language has carried out an entirely justifiable piece of unification in creating the word ‘love’ with its numerous uses, and that we cannot do better than take it as the basis of our scientific discussions and expositions as well” (1921c).

The concept of “genital love” has meaning only if it is associated with the concept of the “genital phase” of libidinal development. It would thus stand in contrast to that which characterizes the object relations of the preceding “pregenital” phases. Genital love should not be understood here solely as love in the form of sexual congress, but as the type of love organized after the oedipal phase and the latency period, at the moment when the libido is sufficiently evolved to enable the organization of the adult genital phase.

Thus, genital love is characterized by the unification, under the primacy of the genital, of all the sexual components that have not been repressed or sublimated, and of those pregenital sexual aims that have been maintained as preliminary pleasures. This unification is prepared during the infantile genital stage and is “completed” only after puberty with the development of adult sexuality.

During the period of oedipal decline, a new distribution of impulse cathexes will leave its traces throughout the sexual life with a new distribution of inhibited or sublimated erotic investments. In particular, there is a conjunction of the sensual erotic current and the affectionate current of adolescence following their relative disjunction during the latency phase. There is a reunion of “genital satisfaction and pregenital affection” (Balint, Michael, 1947). The union of these two currents brings about an equilibrium that is rarely static but can rather be compared to an interlacing, a struggle (Parat, Catherine, 1996).

The model of adult genital organization implies the choice of a heterosexual object, which leads to the reproduction, in a couple, of what was for the child the representation of the couple created by his or her parents. This assumes that the sexual nature of the

images of the parents that were internalized during the oedipal phase have been sufficiently differentiated. In this sense genital love, that is, adult genital organization, is indeed the successor of the oedipal complex, and assumes further that it renounces the oedipal objects formed during childhood (Perron, Roger, Perron-Borelli, Michèle, 1994). Genital, or post-oedipal love, is the form of love best able to articulate the two currents—heterosexual and homosexual—of oedipal love. Positive oedipal erotic investments are reflected onto the sexual partner in the couple, while homosexual investments will nourish, in a more or less desexualized form, social and professional relations.

Michael Balint (1947) emphasized the idealist nature of a concept that would manifest no trace of ambivalence or pregenital object relation. This type of ideal object relation would, therefore, contain no oral characteristics, would have no desire to devour the object; there would be no desire to dominate or master the object, no sadistic traits and therefore no vestige of anality; there would be neither envy nor fear of the genital organs of the other sex, therefore no trace of the phallic phase or castration complex, and so on. Clearly, such love does not exist. The pregenital components cannot all be integrated and every love assumes the destruction of the narcissistic “shell.” We are justified, then, in emphasizing the idealist nature of such a concept, even its normative aura. This does not mean that a certain maturation of the ego and its abilities does not take place gradually when the genital phase of libidinal development is achieved. The state of being in love (David, Christian, 1996) then becomes possible: it is the result of the simultaneous activity of free sexual tendencies and inhibited tendencies and, in particular, of the union of sensuality and affection.

JEAN-FRANÇOIS RABAIN

*See also:* Aberastury, Arminda, known as “La Negra”; Adolescence; Genital stage; Love; Organization; Partial drive; Pregenital; Psychosexual development; Puberty; *Three Essays on the Theory of Sexuality*

### **Bibliography**

- Balint, Michael. (1972). *L'amour génital. Amour primaire et Technique psychanalytique*. Paris: Payot. (Original work published 1947)
- David, Christian. (1996). Post-scriptum à l'état amoureux. *Revue française de psychanalyse*, 60 (3), 633–642.

Parat, Catherine. (1996). À propos de l'amour et de l'amour de transfert. *Revue française de psychanalyse*, 60 (3), 643–662.

Perron, Roger and Perron-Borelli, Michèle. (1994). *Le Complexe d'Œdipe*. Paris: Presses Universitaires de France.

*Revue française de psychanalyse* (1996).

## GENITAL STAGE

A stage or phase of psychosexual development, the *genital stage* is characterized by the organization of the component instincts under the primacy of the genital zone. It is divided into two periods separated by the latency period: first, the infantile genital organization, or phallic phase, dominated by the phallus, that is, by the male genital organ alone, and, secondly, the genital organization properly so-called, which is established at puberty.

Many authors feel that the terms “genital stage” or “genital organization” should be reserved for this second period, and that the “infantile genital organization” or “phallic phase” should properly be classed with the (oral and anal) pregenital organizations that precede latency. Freud himself at first described the genital organization as linked to the discovery of the sexual object at the time of puberty (1905d). Under the primacy of the genital zone, a prerequisite to the union of the sexes, the component instincts of the young child’s “polymorphously perverse” sexuality were unified and integrated into sexual activity as fore-pleasure.

In a paper of 1923, “The Infantile Genital Organization,” intended as a complement to his *Three Essays on the Theory of Sexuality*, Freud moved away from the standpoint of biological maturation, reduced the significance previously accorded to puberty, and described an organization that approximated “(in about the fifth year) to the definitive form taken by [sexuality] in the adult” (1923e, p. 141).

There are two important points here. Object-choices, as first made during this phase, are in every way analogous to post-pubertal choices, and this is “the closest approximation possible in childhood to the final form taken by sexual life after puberty” (p. 142). The second and even more important point is that the infantile genital organization, which is simultaneous with the emergence of the Oedipus complex, is marked by the presence of a particular sexual theory:

the child at this time conceives of but one kind of genital, namely the male sexual organ. This is the reason for the denomination “phallic phase”: “At the same time, the main characteristic of this ‘infantile genital organization’ is its *difference* from the final genital organization of the adult. This consists in the fact that, for both sexes, only one genital, namely the male one, comes into account. What is present, therefore, is not a primacy of the genitals, but a primacy of the *phallus*.” (p. 142)

The idea of the primacy of the male genital organ thus became the foundation of the general theory of the castration complex, of which Freud sought thenceforward to frame feminine as well as masculine versions: “the significance of the castration complex can only be rightly appreciated if its origin in the phase of phallic primacy is also taken into account” (p.144). In *An Outline of Psycho-Analysis*, Freud placed the phallic phase as a pregenital organization following the oral and anal organizations, and reserved the term “genital organization” or “phase” for the pubertal period only. He reasserted the idea that “The complete organization is only achieved at puberty, in a fourth, genital phase” (1940a, p. 155).

It is worth recalling here the importance of the notion of organization. Each phase of development sets up a functional system that organizes not only the current state of mental operation but also its future state. Thus, in 1923, Freud summarized the transformations that the polarity between the sexes undergoes during infantile sexual development as follows: “At the stage of the pregenital sadistic-anal organization, there is as yet no question of male and female; the antithesis between *active* and *passive* is the dominant one. At the following stage of infantile genital organization, which we now know about, *maleness* exists, but not femaleness. The antithesis here is between having a *male genital* and being *castrated*. It is not until development has reached its completion at puberty that the sexual polarity coincides with *male* and *female*” (1923e, p. 145).

Even though the evolution of Freud’s view of psychosexual development led him to assimilate infantile sexuality more and more to adult sexuality, he did not alter his initial assertion: he continued to maintain that it was only with the advent of the sexual organization of puberty that the component instincts were definitively unified and a hierarchy established; the child could not emerge from the anarchy of the component

instincts until, at puberty, the primacy of the genital zone was assured.

JEAN-FRANÇOIS RABAIN

*See also:* Adolescent crisis; Genital love; Phobias in children; Stage (or phase).

### **Bibliography**

- Brusset, Bernard. (1992). *Le Développement libidinal*. Paris: Presses Universitaires de France.
- Freud, Sigmund. (1905d). Three essays on the theory of sexuality. *SE*, 7: 123–243.
- . (1923e). The infantile genital organization (An interpolation into the theory of sexuality). *SE*, 19: 141–145.
- . (1940a). An outline of psycho-analysis. *SE*, 23: 139–207.

### **Further Reading**

- Dorsey, Denise. (1996). Castration anxiety or feminine genital anxiety? *Journal of the American Psychoanalytic Association*, 44(S), 283–302.
- Harley, Marjorie. (1961). Some observations on the relationship between genitality and structural development at adolescence. *Journal of the American Psychoanalytic Association*, 9, 434–460.
- Roiphe, Herman. (1968). On an early genital phase: With an addendum on genesis. *Psychoanalytic Study of the Child*, 23, 348–368.

## **GERMAN ROMANTICISM AND PSYCHOANALYSIS**

Romanticism, according to Thomas Mann, was “the most revolutionary and most radical” movement of the “German spirit.” Along with Judaism and the Enlightenment, it was one of Sigmund Freud’s main sources of inspiration. The culture of the age of Johann Wolfgang von Goethe infused his childhood and youth, but also the whole of the nineteenth century, which was steeped in post-romantic elements such as Darwinism and the resurgence, in Germany, of *Naturphilosophie*, forgotten at the end of the century (Ellenberger, 1974). Freud’s knowledge of certain romantic works of literature is attested by their presence in his library and by the 130 citations of them that appear in his writings.

If Freud was ambivalent with regard to romanticism, this may have to do with his disillusionment, during his youth, with the pan-Germanism (part of the post-romantic trend) of student circles in Vienna when he arrived at the university in 1873 and joined the Reading Circle of Viennese Students, whose “Wagnerism” soon veered toward nationalism and anti-Semitism (MacGrath, 1974).

On the other hand, all of the themes for which romantic science and medicine had laid the groundwork were to be found in psychoanalysis a century later: dreams and their “psychic value,” instinct, repression, the lifting of which is the source of “the uncanny” (Friedrich von Schelling)—the *unheimlich* being a central concept in both romanticism and psychoanalysis, Friedrich Schleiermacher’s secularized interpretations, which he even applied to speech, and of course *Witz*, that alloy of Jewish thought and romantic irony theorized by Jean Paul and August Wilhelm von Schegel, on whom Freud relied, along with Heinrich Heine, whose work he cited numerous times in his writings. A “defrocked romantic,” Heine was also Freud’s model as an atheist Jew, a “brother in unbelief” to Spinoza, one of the romantics’ sources. They gave Eros and sexuality an essential place, and, by elevating the individual ego, took on the conquest of inner freedom. We should also recall the “conquistador” status of Freud himself and the open, “interminable” form of his work.

Freud’s teacher Ernst Brücke had trained him in experimental physiology in a spirit of physico-chemical reductionism, which, in its opposition to the *Naturphilosophie* of his own teacher, Johannes von Müller, nevertheless allowed a romantic heritage to filter through in Freud’s work. It was brought forth by his self-analysis—in the tradition of the knowledge of self of the romantic *Bildung*—with Wilhelm Fliess, an adept of romantic biology who transmitted to him, notably, the idea of primal bisexuality. Freud then practiced hypnosis—the heritage of animal magnetism—to create, through a radical transformation, the psychoanalytic cure. At the same time, he drew upon the post-romantics of his own time to support his work: the theosophist Gustav Fechner, from whom he borrowed the concepts of topography and the pleasure principle, Theodor Lipps, for the unconscious, and Karl Scherner for dreams. At the time of the shift in his thinking in the 1920s, with the dualism of the instincts, Freud can be seen as returning to the “primal

antithesis of the world” of *Naturphilosophie*, and he later took part in an essential discussion with Romain Rolland, “the last of the great French romantics.”

In “A Short Account of Psycho-Analysis” (1924f) Freud alluded to romanticism as an element in the prehistory of psychoanalysis, while Ludwig Binswanger pointed out Freud’s faithfulness to the concept of nature as “mythical essence,” and Thomas Mann assessed psychoanalysis as a romanticism turned scientific.

MADELEINE VERMOREL AND HENRI VERMOREL

*See also:* Goethe and psychoanalysis; Individual; Individuation (analytical psychology); Judaism and psychoanalysis; Sublimation.

### **Bibliography**

Ellenberger, Henri. (1970). *The discovery of the unconscious: The history and evolution of dynamic psychiatry*. New York: Basic Books.

Freud, Sigmund. (1924f). A short account of psycho-analysis. *SE*, 19: 189–209.

MacGrath, William J. (1974). *Dionysian and populist politics in Austria*. New Haven; London: Yale University Press.

Mann, Thomas. (1936). Freud and the future. *International Journal of Psycho-Analysis*, 37 (1), 106–115.

———. (1941). Freud’s position in the history of modern culture. *Psychoanalytic Review*, 28(1), 92–116.

Vermorel, Henri, and Madeleine Vermorel. (1986). Freud et la culture allemande. *Revue française de psychanalyse*, 49, 1034–62.

## **GERMANY**

The first contacts between psychoanalysis and Germany occurred during the discussions and correspondence between Freud and Wilhelm Fliess at the end of the 1890s and continued through Freud’s student Felix Gattel. Between 1907 and 1910 psychiatrists who formed part of the entourage of Otto Binswanger, professor of psychiatry at Jena, became familiar with the “cathartic method.” They included Wolfgang Warda, Wilhelm Strohmayer, Arnold Georg Stegmann, Georg Wanke, Iwan Bloch, Arthur Muthmann, Otto Juliusburger, and Jaroslav Marcinowski.

The first systematic application of psychoanalysis in Berlin was carried out by Karl Abraham, a student of

Carl Gustav Jung and Eugen Bleuler. Abraham was in close contact with Freud since 1908 and was responsible for the first meeting of the Berliner Psychoanalytische Vereinigung (Berlin Psychoanalytic Association) on August 27, 1908, which involved a group of local doctors, including Magnus Hirschfeld (a sex researcher), Iwan Bloch (dermatology, human sexuality), Otto Juliusburger (psychiatry, abstinence), and Heinrich Koerber (circle of Monists). Later its members included Max Eitingon and Mosche Wulff. In 1910 the International Psychoanalytical Association was founded on the occasion of the second international congress of psychoanalysis in Nuremberg, with the Berlin Psychoanalytic Association the leading regional group. By the end of 1911 the Berlin association had eleven members, including three women, Tatiana Rosenthal, Karen Horney, and Margarete Stegmann, the first women analysts. In June 1912 two other nonphysician women were admitted as members at large.

Since German psychiatrists resisted psychoanalysis, recognition took place through various cultural movements (sexual liberation, the emancipation of women, judicial reform, monism). At the time two psychoanalytic congresses were held in Germany: the Weimar congress on September 21, 1911 and the Munich congress on September 7, 1913. The Berlin Psychoanalytic Association underwent qualitative consolidation in an effort to set itself apart from the sexual sciences (after the exclusion of Magnus Hirschfeld in 1911) and in reaction to the defection of Carl Jung, who gave up the presidency of the International Psychoanalytical Association in 1913 and was supported by the Munich group.

Aside from its institutionalization, psychoanalysis received a welcome reception in literature (from authors Lou Andreas-Salomé, Hermann Hesse, Rainer Maria Rilke, Alfred Döblin). Indeed, the city of Frankfurt awarded Sigmund Freud the Goethe Prize in 1930. It was also well received in art (though the mediation of Otto Gros, who was part of the action group that included F. Pfemfert, F. Jung, E. Mühsam). Georg Wilhelm Pabst’s film *Geheimnisse einer Seele* (The mysteries of a soul; 1926) was made in collaboration with Karl Abraham and Hanns Sachs.

Georg Groddeck, the “wild analyst” and the “father of psychosomatics,” opened a fifteen-bed clinic in Baden-Baden. During World War I, an opportunity arose to prove the effectiveness of psychoanalysis in

treating war neuroses. This had the effect of identifying the majority of analysts with the objectives of the war (with the exception of Helene Stöcker and Siegfried Bernfeld) and enabled them to maintain international scientific dialogue (for example, through the publication of the *Internationale Zeitschrift für Psychoanalyse*). Official recognition of psychoanalysis grew, as demonstrated by the presence of government representatives from Austria, Germany, and Hungary at the 1918 Budapest congress, whose theme was the use of psychoanalysis in treating war neuroses. It was here that Sigmund Freud spoke in favor of the use of mass psychoanalysis. In 1919 the Internationaler Psychoanalytischer Verlag (International Psychoanalytic Press) was founded in Leipzig (later in March 1936 the Nazis confiscated the firm's inventory).

The executive board of the Berlin Psychoanalytic Association appointed Max Eitingon, Ernst Simmel, and Karl Abraham on September 26, 1919, to head the Poliklinik für psychoanalytische Behandlung nervöser Krankheiten (Polyclinic for the Psychoanalytic Treatment of Mental Illnesses), which opened on February 16, 1920. Though the Berlin Psychoanalytic Association managed the Berlin Psychoanalytic Institute and the polyclinic, Max Eitingon owned the physical assets and library. He financed the association with an annual fund of 16,000 Reichsmarks. Annual elections were held for the various positions (polyclinic, teaching, candidate, cash management, and subventions). The association grew through an influx of Hungarian analysts fleeing the revolution and counterrevolution, as well as the arrival of analysts from other countries, who were attracted by the freedom and liberality of the Weimar Republic and the then favorable economic situation in Germany. From 1923 the training of analysts was systematized according to guidelines established by Max Eitingon, Carl Müller-Braunschweig, and Sándor Radó and included theoretical courses, a required analysis, and supervised analyses. In 1925 analytic treatment was recognized by a new Prussian order on honoraria (PREUGO) and the German doctor's agreement (ADGO). Following the death of Karl Abraham (on December 25, 1925), Ernst Simmel became director of the association (Sándor Radó was secretary, and Karen Horney was treasurer). On April 24, 1926, the association, in compliance with the international guidelines introduced by Ernest Jones, president of the International Psychoanalytical Association, became the Deutsche psychoanalytische Gesellschaft (DPG; German Psychoanalytic Society).

Germany was host to international psychoanalytic congresses in 1922 (Berlin), 1925 (Bad Homburg), and 1932 (Wiesbaden), as well as a couple of national conferences in 1924 (Würzburg) and 1930 (Dresden). Psychoanalytic work groups were formed in Leipzig in 1919 around Karl H. Voitel (from which a second group formed in September 1922 with Therese Benedek at its head), in Frankfurt in 1926 (with members Karl Landauer and Heinrich Meng), in Stuttgart in 1930 (with members Gustav Hans Graber and Hermann Gundert), and in Hamburg in 1930 (with members Clara Happel and August Watermann).

In 1929 the Südwestdeutsche psychoanalytische Arbeitsgemeinschaft (Southwest German Psychoanalytic Work Group, with members Karl Landauer, Heinrich Meng, and Frieda Fromm-Reichmann) was formed in Frankfurt in close collaboration with the Institut für Sozialforschung (Institute for Social Research) (with members Max Horkheimer and Theodor Adorno). This work group sought to diffuse psychoanalysis by providing training analysis and classes on theory held at the university for candidates without any therapeutic training. A few psychoanalytic clinics were established, though they soon closed for lack of financing. There were the Therapeutikum (from 1924 to 1928, with room for fifteen patients), founded by Erich Fromm and Frieda Fromm-Reichmann in Heidelberg to create a bridge between orthodox Judaism and psychoanalysis, and the Schloss Tegel sanatorium in Berlin (from April 1927 to August 1931) for the treatment of serious neuroses, addictions, and character disturbances.

In 1928 Max Eitingon became president of Internationaler psychoanalytischer Verlag. On January 13, 1931, he was elected president of the DPG, and was assisted by Felix Boehm, Hanns Sachs, and Ernst Simmel.

On April 7, 1933, a law restoring the "office of professions" was issued by the National Socialist government, followed, on April 9, 1933, by an "Aryanization" order directed at medical organizations. On April 22, 1933, medical health insurers started excluding "non-Aryan" doctors, and psychoanalysis was attacked as a "Jewish" science. Yet many eminent non-Jewish representatives of the profession, such as Felix Boehm and Carl Müller-Braunschweig, believed, as did National Socialism itself, that psychoanalysis was an effective therapeutic practice. Many eminent leftist psychoanalysts, including Wilhelm Reich, Otto Fenichel, and

Ernst Simmel, considered psychoanalysis to have a worldview opposed to National Socialism.

At the annual DPG meeting of May 6, 1933, when Boehm and Müller-Braunschweig proposed Aryanizing the presidency, most members voted against the change (eight out of fifteen, with five abstentions). On May 10, 1933, the works of Sigmund Freud, along with those of other psychoanalysts, were burned. On November 18, 1933, Boehm and Müller-Braunschweig assumed control of the society, and on December 31, 1933, Max Eitingon left Berlin.

At the annual DPG meeting held on December 1, 1935, the society, with the assistance of Ernst Jones, president of the International Psychoanalytical Association, refused to dissolve and decided to remain within the association. However, it required its Jewish members to leave the society. By 1936, 74 analysts had left Germany. Salomea Kempner, August Watermann, and Karl Landauer did not survive their incarceration by the National Socialists.

Some members of the DPG resisted the regime: Edith Jacobsohn fought with the socialist resistance group *Neu Beginnen* (New Beginnings). She was arrested on October 24, 1935, but managed to escape and fled to the United States. The DPG then passed a resolution that required members to abstain from politics. In February 1937 Käthe Dräger became head of the Berlin committee of the KPD-Opposition (the opposition group formed to fight the German communist party, or KPD). She wrote and distributed antifascist writings and tracts, and helped the families of comrades who had been jailed. In 1937 John Rittmeister was forced to flee Switzerland for “communist activity,” and in 1941 he joined the resistance group that had formed around H. Schultze-Boysen (the *Rote Kapelle*, or Red Orchestra). He was arrested on September 26, 1942, and executed on May 13, 1943. Fourteen psychoanalysts remained in Germany.

Discussions between Felix Boehm (president of the DPG), Sigmund and Anna Freud, and other leading analysts gave Boehm the impression of a certain neutrality toward or even support for his and the DPG’s adaptation to the National Socialist regime. But those involved did not want to further complicate matters, though they did not agree with his political views or the ideological conformism of Müller-Braunschweig. The Ministry of the Interior told Boehm that to obtain authorization to teach, he, as president of the DPG,

had to fold the other psychotherapeutic organizations into the *Deutsches Institut für psychologische Forschung und Psychotherapie* (German Institute for Psychological Research and Psychotherapy), which was to be under National Socialist control and run by Professor Matthias Heinrich Göring.

The new institute was founded in May 1936, and Max Eitingon’s assets “inventoried.” This was the beginning of the development of a “German psychotherapy,” an eclectic mix of different psychotherapeutic theories. The DPG was dissolved on November 19, 1938, after an aborted attempt by Müller-Braunschweig to transfer the *Wiener Psychoanalytische Vereinigung* (WPV; Vienna Psychoanalytic Society) and the publishing house to the German Institute for Psychological Research and Psychotherapy, within which it would become working group A.

Although Boehm and Müller-Braunschweig were officially banned from teaching and publishing, they were both important collaborators of the institute. They ran the polyclinic, and Boehm coordinated the working group on homosexuality, while Müller-Braunschweig coordinated the teaching program. The ban on the use of psychoanalytic terminology did not affect Harald Schultz-Hencke, however, who in 1933 developed a form of “neopsychanalysis,” an amalgam of current psychoanalytic teachings, by abandoning metapsychology and other essential elements of analysis.

Of the 300 members of the medical staff of the German Institute (including 17 members of the DPG/WPV), 41 were members of the Nazi party (the *Nationalsozialistische Deutsche Arbeiterpartei*), and of the 145 members who were not doctors (25 of whom were members of the DPG/WPV), 22 were party members. Although most of the DPG members remaining in Germany had managed to adapt to the Nazi regime, only Doctor Gerhard Scheunert was a member of the Nazi party. The German Institute, by then solidly established, was recognized by the union of German workers, financed by the *Luftwaffe* and private insurers, and, during the war, was “assigned to the war effort.” Eventually it was raised to the level of a government institute within the Reich’s research council (*Reichsinstitut im Reichsforschungsrat*), with an annual budget of 880,000 Reichsmarks.

After the war, though participants claimed to have sought to “save psychoanalysis” by their underground

presence, they faced considerable skepticism and criticism from colleagues living abroad. On October 16, 1945, the DPG was reestablished with Müller-Braunschweig as its first president, Boehm as representative, and Werner Kemper as the third member of the office staff. It had 35 ordinary members and 2 members at large, 12 of whom had been trained between 1936 and 1945. On April 29, 1946, it resumed activities (as the Berliner Psychoanalytische Gesellschaft until December 3, 1950), but the British military authorities forced the DPG to strike any mention of being a “member of the International Psychoanalytical Association.” On May 9, 1947, the Institut für Psychotherapie was founded in Berlin, with teachers from a variety of psychotherapeutic backgrounds, to provide training in psychotherapy; in 1948 the institute also began training “education counselors,” or *Psychagogen* (child and adolescent therapists).

During the first postwar International Congress of Psychoanalysis, which took place in Zurich in 1949, the confrontation between Harald Schultz-Hencke’s neops psychoanalysis and the conventional Freudian position of Müller-Braunschweig reached its culmination. The DPG was provisionally admitted to the International Psychoanalytical Association, subject to the requirement that its members state their position openly.

On May 13, 1950, Müller-Braunschweig, unsuccessful in his attempts to obtain recognition from Schultz-Hencke, secretly founded the Deutsche psychoanalytische Vereinigung (DPV; German Psychoanalytic Association). The DPV was admitted to the International Psychoanalytical Association at the 1951 Amsterdam congress, but not the DPG. The DPG only succeeded in regaining membership as the IPA Executive Council Provisional Society at the IPA Congress in Nice in 2001. In 2004 the DPV was the second largest group within the International Psychoanalytical Association in terms of number of members. At the suggestion of Werner Schwidder (member of the DPG and student of Schultz-Hencke), the DPG, in 1962, joined with other neops psychoanalytic groups to form the Internationale Föderation psychoanalytischer Gesellschaften (International Federation of Psychoanalytic Societies), comprising twenty individual societies in Europe, North America, and South America.

In spite of struggles for influence between the DPG and the DPV, which were just beginning to ease, in 1949 Wilhelm Bitter founded the Deutsche Gesellschaft für

Psychoanalyse, Psychotherapie, Psychosomatik und Tiefenpsychologie (German Society for Psychoanalysis, Psychotherapy, Psychosomatics, and Depth Psychology), a professional organization incorporating the major trends in depth psychology (neops psychoanalysis, conventional Freudianism, Jungian analysis, Adlerian analysis). The member societies took turns supplying presidents. As of 2004, it had approximately 3,150 members in 45 institutes, which are recognized by the kassenärztliche Bundesvereinigung (German association of registered physicians) and German medical associations as establishments providing further education to become child and youth analytical psychotherapists. Outside Berlin, working groups and psychotherapeutic establishments were created in Munich (the successor of the German Institute for Psychological Research and Psychotherapy and the mobile psychosomatic service of Johann Cremerius), Stuttgart (the working group in 1946, and in 1948 the Institut für Psychotherapie und Tiefenpsychologie [Institute for Psychotherapy and Depth Psychology], representing the various forms of depth psychology and founded by Wilhelm Bitter, Hermann Gundert, and Felix Schottlaender), Heidelberg (the department of psychosomatics run by Alexander Mitscherlich), Bremen (the working group founded by Hildegard Buder in 1949, and an institute founded by R. W. Schulte and Franz Rudolf Haarstrick in 1951), and Göttingen (the Tiefenbrunn regional hospital, founded by G. Kühnel and W. Schwidder). Later, institutes were created in all the major cities of the Federal Republic of Germany. The Berlin institute gradually lost its importance and was overshadowed by the institute founded in Frankfurt in 1961 under the direction of Alexander Mitscherlich and associated with the university. This was the Institut und Ausbildungszentrum für Psychoanalyse und psychosomatische Medizin (Institute and Learning Center for Psychoanalysis and Psychosomatic Medicine), which was renamed the Sigmund Freud Institute in 1964.

Mitscherlich and his wife, Margarete Mitscherlich-Nielsen, not only renewed relations with the Institute of Social Research (where Max Horkheimer and Theodor Adorno were central figures) but also initiated a dialog with the international psychoanalytic community concerning the controversies associated with Germany’s National Socialist past. Sparked by criticisms from the student movement, interest in social policies, group therapy, and family therapy grew (relevant authors include Horst-Eberhard Richter, Franz Heigl, Anneliese Heigl-Evers). The “Bernfeld Circle”



(Johannes Cremerius) began to question the training and qualifications of analysts, the issue of feminism, and the various polemics surrounding psychoanalysis (Christa Rhode-Dachser).

In the German Democratic Republic, ideology interfered with the resumption of a psychoanalytic tradition, although there was relative tolerance for neopsychoanalysis. In an initial phase running from 1945 to 1949, the analysts Werner Kemper (West Berlin), Alexander Mette (Weimar), and Franz Baumeyer (Arnsdorf) were among the dozen psychiatrists responsible for training and accrediting “mental health caretakers and psychotherapists.” In Leipzig, the neurologist A. Beerholdt, although he never completed his analytic coursework, was able to introduce psychoanalysis to several psychiatrists (Wendt, Starke, Behrendt, Böttcher). The only trained psychoanalyst remaining in the German Democratic Republic, Alexander Mette, left psychoanalysis to start a career in politics (he pursued an initial interest in health policies, then a university career, and eventually became a member of the chamber of deputies of the German Democratic Republic and a member of the central committee of the Socialist Unity Party). The contents of psychoanalytic discussions were determined by Harald Schultz-Hencke and his followers, Werner Schwidder, U. Derbolowsky, and G. Kühnel. Schultz-Hencke’s appointment as professor at Humboldt University on September 29, 1949, led the DPG to issue a resolution forbidding members from taking posts in both East and West Germany, and Schultz-Hencke gave up his professorship. Following the creation of the German Democratic Republic on October 7, 1949, psychotherapeutic establishments were created in Jena and Leipzig.

From 1950 to 1962, while psychoanalysis was expanding in the United States and an antipsychoanalytic movement was taking place in the Soviet Union (where Freud’s work represented a facet of National Socialist ideology), the trend in the German Democratic Republic turned to Pavlovianism. Associated with the therapeutic tradition of Otto Binswanger, Johannes H. Schultz, Ernst Speer, and O. Vogt, in 1951 a department of psychotherapy was opened at the medical polyclinic. There they developed a medical-materialist “rational psychotherapy” intended to replace neopsychoanalysis.

The period from 1963 to 1976, when H. Kleinsorge was president of the DPG, was characterized by greater

openness in discussions of psychotherapies and in international relations. In the society a number of sections were set up, organized according to method rather than their theoretical leanings: psychodynamic therapy, group therapy, autogenic training and hypnosis, infant therapy, music therapy. Between 1976 and 1984 recognition was granted to “medical specialists in psychotherapy” and “medical psychologists” (August 1978), and individual therapy was reintroduced. Fifteen regional societies of psychotherapy were created to cover psychotherapeutic needs and the basic training of doctors, and interdisciplinary working groups were formed to further integrate psychoanalysis with the medical field. After 1985 efforts were made to institutionalize psychotherapy in the universities by creating autonomous chairs of psychotherapy and medical psychology, and psychoanalytically oriented research on the body helped to conceptualize group therapy. Access to the psychoanalytic literature was still limited, however: Freud was first published in the German Democratic Republic as late as 1983.

In September 1947, the Studiengesellschaft für praktische Psychologie (Research Society for Practical Psychology) was formed in West Germany for representatives of all the academic professions concerned with the individual. Ever since 1945, in the university exams given to psychologists, psychoanalysis appeared under “depth psychology and education counseling.” After the educational reforms of 1973, it appeared in the larger field of “clinical psychology,” comprising the study of testing, prevention, rehabilitation, counseling, and other areas outside the field of depth psychology.

Gradually, psychoanalysis disappeared from higher education to be taught in training institutes and the psychosomatic departments of medical schools. Nonetheless, in experimental psychology, psychoanalysis remained the most systematic and most studied psychological theory in 1977. At the beginning of the 1980s, the emphasis on the interpretation of psychoanalytic texts brought about through the influence of Jacques Lacan made its appearance in German scholarship. After 1970 medical psychology and sociology, as well as psychotherapy and psychosomatics, became required material for students of medicine and resulted in the creation of the corresponding chairs and, in some cases, university departments. In 1979 the DPG created a psychoanalysis section alongside psychotherapy, and psychoanalysis became a part of the continuing training of doctors. At the start of the

1990s, specialist medical training included fields such as “psychotherapeutic medicine,” “psychiatry and psychotherapy,” “psychiatry and psychotherapy of children and adolescents.”

With respect to the relations between psychoanalysis and insurers, the Einheitskrankenkasse and the Rentenversicherung, in Berlin, had financed the Zentralinstitut für psychogene Erkrankungen der Versicherungsanstalt Berlin (Central Insurance Institute of Berlin for Mental Illness), founded by Werner Kemper and Harald Schultz-Hencke. By 1955 insurance reforms in Berlin had gradually done away with many of these organizations, but the Central Insurance Institute remains. Empirical follow-up work on outpatients by Franz Baumeyer and Annemarie Dührssen made legal recognition of psychotherapy possible. In 1960 the “Munich model” was instituted; this system involved the sharing of medical expenses among the government (for employees), insurers, and patients, each paying a third. In 1967 psychological and psychoanalytic therapies became covered general medical expenses for which insurers were responsible, following verification of the illness. In 1968 insurers (and in 1971 mutual insurance companies as well) started covering psychotherapy under certain conditions, and they also covered child therapies. On July 1, 1976, the medical committee and insurers modified the guidelines for analytic therapies to recognize neurosis as an illness. Psychosomatic treatment became covered from October 1, 1987. In therapy, if the symptoms are recognized, reimbursement covers 160 fifty-minute hours of treatment, with 80 to 140 additional hours possible. Psychologists who have received analytic training can provide psychoanalytic treatments. With the passing of a law regulating psychotherapists (June 16, 1998), “psychological psychotherapists” and child and youth therapists now require a license to practice medicine.

Among journals, one of the most important is *Psyche*, which began by focusing on depth psychology but later broadened its coverage to include cultural trends. *Jahrbuch der Psychoanalyse* published contributions to the theory, practice, and history of psychoanalysis. *Forum der Psychoanalyse* and *Zeitschrift für psychoanalytische Theorie und Praxis* are clinical in orientation. Other journals include *Praxis der Psychotherapie und Psychosomatik* and *Zeitschrift für psychosomatische Medizin und Psychoanalyse*.

Until the end of the 1960s, the DPG and the DPV were separated by their divergent theoretical positions

concerning Harald Schultz-Hencke’s neopsychanalysis. Since then, the DPG’s orientation has shifted to a more international position focused on the ego and the self and on the theory of object relations. Moreover, it has generally supported the classical Freudian position. However, there has been growing interest within both the DPV and the DPG for the Kleinian position, and contacts have developed with the “Middle Group” of the British Psycho-Analytical Society. Though there are a few theoretical differences (Rudolf, 1987), there are more differences in practice. For example, in training analysis the DPV recommends four sessions, and the DPG three.

After accounts were settled over Alexander Mitscherlich’s involvement with National Socialism, a reckoning that took place over a twenty-five-year period following the war, the first postwar congress of the International Psychoanalytical Association in Germany was held in Hamburg in 1985. At the congress there was a growing interest in the history of psychoanalysis, its development (Karen Brecht, Volker Friedrich, Ludger Hermanns, Dierk Juelich, Isidor Kaminer, and Regine Lockot), and its interpretation (Hermann Beland, Ermann). In 1995 and 1996 conferences between groups of German and Israeli psychoanalysts took place (H. Beland). In 1996 the first joint DPG-DPV conference was held on “the division of the psychoanalytic community in Germany and its consequences.” In 1996 the two societies, the DPG and DPV, had nearly the same number of members (approximately five hundred each).

REGINE LOCKOT

### Bibliography

- Haarstrick, Franz Rudolf. (1994). Die Entwicklung des Gutachterverfahrens in der Psychotherapie. *Arbeitskreis Deutschen Gesellschaft für Psychoanalyse, Psychotherapie, Psychosomatik und Tiefenpsychologie/Vereinigung Analytischer Kinder—und Jugendlichen—Psychotherapeuten*, 4.
- Hermanns, Ludger M. (1994). Karl Abraham und die Anfänge der Berliner psychoanalytischen Vereinigung. *Luzifer-Amor*, 13, 30–40.
- Höck, Kurt. (1988). *Entwicklung der Balint-Gruppenarbeit in der D.D.R. Klinik und Praxis*. Berlin: Springer.
- Lockot, Regine. (1985). *Erinnern und Durcharbeiten: zur Geschichte der Psychoanalyse und Psychotherapie im Nationalsozialismus*. Frankfurt am Main: S. Fischer.
- Rudolf, Gerd. (1987). Vergleich der Akzeptanz psychoanalytischer Konzepte von I.P.A.- und D.P.G.-Mitgliedern.

## GESAMMELTE SCHRIFTEN

The twelve volumes of the *Gesammelte Schriften* constitute the first publication of Freud's complete (or almost complete) works in his native language. They were published by the Internationaler Psychoanalytischer Verlag.

This edition was undoubtedly planned when Freud was ill with cancer in 1923, and it was originally limited to ten volumes. Volumes 4, 5, 7, 8, and 10 appeared in 1924, volumes 1, 2, 3, 6, and 9 in the following year. Since Freud remained productive despite his illness, an eleventh volume containing his writings from the interim was published in 1928, and in 1934 a final volume appeared that brought together "the writings of 1928–33" and various additions to Volumes 1–11. Anna Freud and Adolf Josef Storfer served as editors for Volumes 1–11 and Otto Rank as their co-editor on Volumes 4, 5, 7, 8, and 10. Anna Freud and Robert Waelder made the selection and provided editorial commentary for Volume 12. As indicated on the endpapers, all volumes were "prepared with the collaboration of the author," and in correspondence Freud several times referred to the *Gesammelte Schriften* as the "complete edition" of his works.

This was not a critical edition, however. The somewhat random composition of Volumes 11 and 12 was the result, to be sure, of their belated conception. Volumes 1–10, envisioned as a whole, were organized by theme. Scholarly apparatus and commentary were minimal. There was no introductory statement of the principles governing the editors' choices and aims, nor was any bibliography or index provided. The only editorial decision of any moment concerned *The Interpretation of Dreams*, the first edition of which magnum opus, Freud's dream-book in its initial form, was offered as the second volume of the *Gesammelte Schriften*, while Volume 3 assembled the many and often voluminous additions that Freud made to the book in its subsequent editions. It was Freud himself who proposed this original way of presenting his great work.

Prior to the publication of the *Gesammelte Schriften*, Freud had for the most part published his work in the form of monographs, articles in journals or annals, or contributions to anthologies and collections. After the founding, in 1919, of his own publishing house, the Internationaler Psychoanalytischer Verlag, he generally published there. It was thus the "twelve volumes in dictionary format" (to quote the publishers'

promotional matter) of the *Gesammelte Schriften* that gave readers their first general view of the full scope and import of Freud's work.

ILSE GRUBRICH-SIMITIS

See also: *Gesammelte Werke*; "Moses of Michelangelo, The"; *Studies on Hysteria*

### Bibliography

Grubrich-Simitis, Ilse. (1993). *Back to Freud's texts. Making silent documents speak*. New Haven and London: Yale University Press.

———. (2000). *Metamorphosen der Traumdeutung*. In Jean Starobinski, Ilse Grubrich-Simitis, and M. Solms, (Eds.) *Hundert Jahre Traumdeutung von Sigmund Freud*. Frankfurt am Main: Fischer Taschenbuch Verlag.

## GESAMMELTE WERKE

The eighteen-volume *Gesammelte Werke*, along with an unnumbered supplemental volume (the *Nachtragsband*) constitutes the second complete edition of Freud's work in German.

In 1939, having emigrated to London, Freud founded the Imago Publishing Company as a successor to the Internationaler Psychoanalytischer Verlag, shut down by the Nazis. The chief purpose was to preserve the Viennese *Gesammelte Schriften*, duly modified, as a new *Gesammelte Werke*. Work on the project was begun as early as the fall of 1938, with Freud participating.

At the outset, the editorial committee consisted of Anna Freud, Edward Bibring, and Ernst Kris. Volumes 1 through 17 appeared between 1940 and 1952, which is to say after Freud's death. Bibring and Kris migrated to the United States in 1940–41, to be replaced by Willi Hoffer and Otto Isakower, who served as co-editors for every volume except 9 and 15, both of which were published in 1944. Marie Bonaparte's collaboration was acknowledged in every volume. Volume 18, planned as a *Gesamtregister* or General Index, was prepared by Lilla Veszy-Wagner, but before the manuscript could be sent to the printer, Imago Publishing Company went bankrupt in 1961. When S. Fischer Verlag of Frankfurt acquired the rights to Freud's works in 1960, they also came into possession of the remaining stock of the seventeen volumes of the *Gesammelte Werke* and the

manuscript of the *Gesamtregister*. After a thoroughgoing revision, Volume 18, the very first general index to Freud's work, finally appeared in 1968. In 1987 the *Nachtragsband*, edited by Angela Richards with the assistance of Ilse Grubrich-Simitis, brought together all of Freud's psychological and psychoanalytical texts that for one reason or another had not been included in the first seventeen volumes of the *Gesammelte Werke*.

Like the *Gesammelte Schriften*, the first seventeen volumes of the *Gesammelte Werke* cannot be described as a critical edition of Freud's work. Editorial comment is reduced to the bare minimum. In contrast to the approach of the *Schriften*, the contents of the *Gesammelte Werke* are ordered chronologically. Volume 2 and 3 reproduce the eighth edition of *The Interpretation of Dreams*, including all the added material.

The *Nachtragsband*, however, is supplied with a serious editorial apparatus and may be considered a critical edition. It is organized by theme, but its overall arrangement is chronological.

The main aim of the editors of Volumes 1-17, working from London during and immediately after the Second World War, was to make Freud's work available in its original language through the book trade. The editorial shortcomings resulted in part from the difficult conditions under which this second edition of Freud's collected works had to be produced; in light of the circumstances the undertaking constituted a remarkable rescue operation. The *Nachtragsband* eked out the set of texts in Volume 1-17 by adding writings that had come to light later, some of them lacking even in the *Standard Edition*, as for example the "Übersicht der Übertragungsneurosen" (Overview of the transference neuroses) of 1915. Some texts, among them the "Project for a Scientific Psychology" and Freud's original notes on the "Rat Man" case, appeared in the *Nachtragsband* in freshly corrected transcriptions.

Until such time, then, as a historico-critical edition is produced, the *Gesammelte Werke* and the *Nachtragsband* together constitute the most comprehensive presentation of Freud's work available in its original language.

ILSE GRUBRICH-SIMITIS

See also: *Gesammelte Schriften*; Imago Publishing Company.

## Bibliography

Grubrich-Simitis, Ilse. (1987). Einleitung. In Sigmund Freud, GW, *Nachtragsband*, Frankfurt am Main: S. Fischer.

———. (1993). *Back to Freud's texts. Making silent documents speak*. New Haven and London: Yale University Press.

---

## GESTAPO

It was not long after the *Anschluss* of March 13, 1938, that the Nazis began to take an interest in the Jew Sigmund Freud. The number of "visits" to the Berggasse residence increased in frequency and were often accompanied by demands for money. One Tuesday evening, on March 22, Anna Freud was held "bei Gestapo" for questioning, which sealed her father's decision to leave Austria.

It has been suggested that "humor is a polite way of expressing despair" and it is not surprising that a number of jokes circulated in Austria at the time. One of them, attributed to Freud himself, has been frequently repeated ever since Ernest Jones reported it: "One of the conditions for being granted an exit visa was that he sign a document that ran as follows, 'I Prof. Freud, hereby confirm that after the Anschluss of Austria to the German Reich I have been treated by the German authorities and particularly the Gestapo with all the respect and consideration due to my scientific reputation, that I could live and work in full freedom, that I could continue to pursue my activities in every way I desired, that I found full support from all concerned in this respect, and that I have not the slightest reason for any complaint.' When the Nazi officer brought it along Freud had of course no compunction in signing it, but he asked if he might be allowed to add a sentence, which was: 'I can heartily recommend the Gestapo to anyone'" (Jones, 1957, p. 226).

This "story" has been repeated many times and commented on by those who treated it as genuine. Some commentators have reproached Freud for a "recommendation" they felt to be ambiguous; others admired his audacity. Eventually, some people ended up believing that Freud had actually added this sentence to the Nazi document.

It is hard to imagine that Freud, who was aware of the difficult and costly negotiations by the U. S. ambassador to France (William C. Bullitt), Marie Bonaparte, and Ernest Jones to obtain his visa, and

who was responsible for the fate of his daughter and wife within the climate of the anti-Semitic hatred that had taken hold in Vienna, would have taken the risk of making a joke that in a matter of seconds might undo all their efforts. Moreover, he was depressed by the powerlessness resulting from his age and poor health, as he wrote in a letter to his son Ernst on May 12, 1938, "I am writing to you for no particular reason because here I am sitting inactive and helpless while Anna runs here and there coping with all the authorities, attending to all the business details" (letter number 297, p. 442). But his "official" biography maintained this fiction, and none of those close to Freud denied it, especially Anna Freud.

The original text of the statement was found during a 1989 public auction of documents concerning the emigration of Freud's family. It is a more sober statement, closer to the horrible truth of those years, than the theatrical version given by Jones, and more consistent with the customary bureaucratic indifference of the Nazi machine. It was written by Alfred Indra and signed by Freud, without any additions by him. It reads: "*Erklärung. Ich bestätige gerne, dass bis heute den 4. Juni 1938, keinerlei Behelligung meiner Person oder meiner Hausgenossen vorgekommen ist. Behörden und Funktionäre der Partei sind mir und meinem Hausgenossen ständig korrekt und rücksichtsvoll entgegnetreten. Wien, den 4. Juni 1938. Prof. Dr. Sigm. Freud.*" (Declaration. I hereby confirm of my own free will that as of today, June 4, 1938, neither I nor those around me have been harassed. The authorities and representatives of the Party have always conducted themselves correctly and with restraint with me and with those around me. Vienna, June 4, 1938. Prof. Dr. Sigm. Freud.)

Freud's comment was most likely introduced to mask the anguish of his departure—a form of black humor, which had close links, throughout Freud's life, with the tradition of Yiddish *Witze*, which were often also tinged with despair.

ALAIN DE MIJOLLA

See also: Bettelheim, Bruno; Freud, (Jean Martin); Internationaler Psychoanalytischer Verlag; Mitscherlich, Alexander.

### **Bibliography**

Jones, Ernest. (1957). *Sigmund Freud. Life and work*. London: Hogarth.

Mijolla, Alain de. (1989). A sale in Vienna. *Journal de l'association internationale d'histoire de la psychanalyse*, 8.

## **GIFT**

Gifts and money are unconsciously associated with anal eroticism. In "On Transformations of Instinct as Exemplified in Anal Eroticism" (1916–1917e), Sigmund Freud writes, "It is probable that the first meaning which a child's interest in faeces develops is that of 'gift' rather than 'gold' or 'money.' . . . Since his faeces are his first gift, the child easily transfers his interest from that substance to the new one which he comes across as the most valuable gift in life. Those who question this derivation of gifts should consider their experience of psycho-analytic treatment, study the gifts they receive as doctors from their patients, and watch the storms of transference which a gift from them can rouse in their patients" (pp. 130–131). The gift is meaningful because of its connection to the libido and eroticism. Freud's investigation led him to the discovery of the unconscious link with defecation and its relation to treasure hunting.

Karl Abraham (1916) examined the connection between excessive giving and anxiety. He investigated (1919) the transference meaning of the associations—occasionally excessive—presented by the patient to the psychoanalyst as a gift. This attitude is an expression of narcissism and is characterized by its view of analysis as something governed by the pleasure principle.

What happens to the instinctual impulses of anal eroticism after the genital organization has been established? Freud in "On Transformations of Instinct as Exemplified in Anal Eroticism" (1916–17e) responds with the idea of the transformation of instinct. In this schema, gift equals excrement according to the symbolic language of the dream and daily life.

The first gift is excrement, a part of the infant's body he gives up only upon the mother's insistence and through which he manifests his love for her. Defecation and its relation to the object thus become the first opportunity for the infant to choose between bodily pleasure (narcissism) and object love (sacrifice).

Later in life the interest in excrement is transferred to an interest in gifts and money. The concepts of excrement, infant, and penis are poorly distinguished

and are frequently treated as if they were equivalent; they can easily be substituted for one another. Freud perceived the identity of the infant with excrement in the linguistic expression: “to give a child.” Similarly, Freud wrote in the “Wolf Man” (1918b), “By way of this detour demonstrating a common point of departure in their significance as gifts, money can now attract to itself the meaning of children, and in this way take over the expression of feminine (homosexual) satisfaction.”

Freud views the transference relation of certain patients as a vague recollection of this problematic, arising whenever the patient wants to interrupt the unfinished treatment and place himself in a situation of disdain that originates in the outside world. The patient then replaces the urgent desire to have a child with promises of significant gifts, most often as unrealistic as the object of his past desire. This concept is developed in *Beyond the Pleasure Principle* (1920g).

Melanie Klein (1932–1975) demonstrated the importance of the theme of poison gifts as a source of depression and melancholy toward the object. “For the child gifts attenuate his guilt by symbolizing the free gift of what he wanted to obtain by sadistic means.” In this same article, Klein clarifies the role of ambivalence and sees it as a step forward compared to archaic mechanisms. The gift provides access; it is a preliminary form of sublimation within the compulsions of reparation and restitution associated with obsessive behavior.

DOMINIQUE J. ARNOUX

See also: Anality; Money in psychoanalytic treatment

### **Bibliography**

Abraham, Karl. (1966). Examen de l'étape prégénitale la plus précoce du développement de la libido. *Complete works*, vol. 2, 1915–1925. (pp. 231–254) (I. Barande, Trans.) Paris: Payot. (Original work published 1916)

———. (1979). A particular form of neurotic resistance against the psycho-analytic method. (pp. 303–311) In *Selected papers of Karl Abraham, M.D.* (Douglas Bryan and Alix Strachey, Trans.) New York: Brunner/Mazel. (Original work published 1927)

Freud, Sigmund. (1908b). Character and anal erotism. *SE*, 9: 169–175.

———. (1916–17e). On transformations of instinct as exemplified in anal erotism. *SE*, 17: 127–133.

———. (1918b). From the history of an infantile neurosis. *SE*, 17: 1–122.

———. (1920g). Beyond the pleasure principle. *SE*, 18: 1–64.

Klein, Melanie. (1975). *The psycho-analysis of children*. (Alix Strachey, Trans.) London: Hogarth Press. (Original work published 1932)

## **GLOVER, EDWARD (1888–1972)**

Edward Glover, British psychoanalyst and physician, was born on January 13, 1888 in Lesmahagow, Scotland, and died August 16, 1972, in London.

Born in a small Scottish village, he was the third and youngest son of a country schoolmaster, Matthew Glover, who, for reasons of health, had previously given up a very promising scholastic University career. His mother, Elizabeth Shanks Glover, had been raised by her uncle, a Minister of the Reformed Presbyterian Church, and she was privately educated in its very firm tenets and strict Sunday observances, as well as in domestic arts. By contrast, Edward's father was Darwinian and agnostic, but Edward was raised in what he regarded as his mother's oppressive religious convictions.

Glover is said to have inherited his literary gifts from his mother, but his father's linguistic expertise and thorough knowledge of Greek, Latin, Hebrew, French, and English must have deeply influenced him. Matthew Glover's interest in natural philosophy, his intellectual rigor, scientific attitude, and capacity to teach was likewise reflected in Edward's selfsame gifts.

But the boy hated his early years of schooling and religious instruction, describing himself as “reluctant, rebellious, contumacious, and obstinate” as a pupil, though he seems otherwise to have had a happy childhood. But, on entering secondary school—under his father's direction—he threw himself into his work with energy and gusto, matriculating at sixteen, starting medical training, and qualifying M.B., Ch.B. with distinction at the age of twenty-one.

He was appointed House Physician to the well-known cardiologist Professor John Cowan at Glasgow Royal Infirmary, and in the next few years learned to apply scientific method to clinical practice and undertook research. Four years later he became Senior Resident at the Glasgow Children's Hospital, and remarked

that there “the facts of psychological life could no longer be gainsaid.” He became Assistant Physician at the Edward VII Sanatorium at Midhurst, greatly admiring the pathologist there, J.A.D. Radcliffe, whom he felt provided him with a disciplined understanding of natural scientific method. Glover’s experience led to significant published contributions to the field of pulmonary medicine.

In following his medical career he had been greatly influenced by his oldest brother, James. His dissatisfaction with a strictly organic approach to medicine—the limitations of which he discovered in the course of his own clinical practice—led him to follow his brother James’s interest in Freud’s psychology. James had moved to Brunswick Square in London to set up a psychiatric practice with Drs. Jessie Murray and Julia Turner. In 1920 the brothers went to Berlin to undergo training analyses (Edward preferred to call his an apprenticeship) with Karl Abraham, studying alongside Ella Freeman Sharpe and Mary Chadwick—also to make their names as psychoanalysts in London. Glover had an honorary appointment there, and learned as much psychiatry as he could from the hospital facilities in Berlin before returning to London, becoming an associate member of the British Psycho-Analytical Society in 1921 and a full member the following year.

James, who was close to Ernest Jones, died in 1926, and Edward took over many of his commitments. He was appointed Scientific Secretary of the British Society, Director of Research, Assistant Director, under Jones, of the London Clinic of Psychoanalysis, and then Secretary of the training committee of the International Psychoanalytic Society. His influence in the British Society was second only to Jones, while his reputation among doctors outside the Society was unsurpassed. He was a fine public speaker and a very gifted writer; and although he sometimes lapsed into polemics, he produced some memorable and witty sayings in the process.

Glover was sufficiently self-critical to recognize that, for a time after his qualification, he had allowed his enthusiasm for psychoanalysis to undermine, at times, the critical and scientific discipline that had become so important to him during his strictly medical work. But it was an error that he soon set about correcting. He became an enemy of what he called “unchecked speculation,” and became, in a series of telling critiques of analysts and former analysts published over the years (most notably, perhaps, *Freud or*

*Jung* [1950]), what someone in another field once called “the necessary antidote to everything.” In this he held firmly to the common ground of basic psychoanalytic concepts. Unhappily, he lived to see that ground becoming increasingly less common.

Much of his work, however, consists of original contributions covering a wide range of psychoanalytic interest. These included: drug addiction; prostitution; *War, Sadism, and Pacifism* (1933); *The Technique Of Psycho-Analysis* (1955); the classification of mental disorders; the early development of mind and the nuclear theory of ego formation; education; and research methods in psychoanalysis. A selection of many key papers appeared in 1956. A classic textbook on psychoanalysis was published in 1939 and substantially enlarged for a second edition in 1949. But, perhaps above all, his contributions to the study of psychopathy and crime reflected his single greatest interest, about which he wrote a large number of papers, the bulk of them gathered together in his book *The Roots of Crime* (1960). From small beginnings in 1922, and in association with Grace Pailthorpe and others, the foundations were laid on which Glover later founded the Institute for the Study and Treatment of Delinquency (ISTD), the clinical wing of which was later adopted by the National Health Service as the Portman Clinic, while the scientific and research division was funded separately. Together with Hermann Mannheim and Emanuel Miller, Glover founded *The British Journal of Delinquency* (later *The British Journal of Criminology*) in 1950 and, together with the ISTD, launched the International Library of Criminology. He was a founding member of the editorial board of *The Psychoanalytic Study of the Child*.

Glover is often remembered in the British Psychoanalytic Society, perhaps unfairly, for the part he played in the series of Controversial Discussions, recorded with great thoroughness and scholarship by Pearl King and Riccardo Steiner in *The Freud-Klein Controversies 1941–45* (1991). Glover’s critique of Klein, later published separately, is still perhaps the most thorough and exhaustive on this topic. His dissent led him to leave the Society in 1944, but he continued to be a member the International Psychoanalytic Association through his honorary membership of the Swiss and American Societies. Glover’s first wife, whom he married in 1918, died eighteen months later from septicemia. He married for a second time in

1924, and their only child, a mentally handicapped girl, was born in 1926.

CLIFFORD YORKE

*See also:* British Psycho-Analytical Society; Splitting of the object; Controversial Discussions; Dipsomania; Great Britain; Indications and contraindications for psychoanalysis for an adult; Schmeiderg-Klein, Melitta; Technique with adults, psychoanalytic.

### **Bibliography**

- Glover, Edward. (1933). *War, sadism and pacifism*. London: Allen and Unwin.
- . (1950). *Freud or Jung*. London: Allen and Unwin.
- . (1955). *The technique of psycho-analysis*. London: Bailliere, Tindall and Cox.
- . (1956). *On the early development of mind. Selected papers*. London: Imago Publishing. Re-issued 1970, New York: International Universities Press.
- . (1960). *The roots of crime*. London: Imago Publishing. Re-issued 1970, New York: International Universities Press.
- King, Pearl H.M.; and Steiner, Riccardo. (1991). *The Freud-Klein controversies 1941–1945*. London and New York: Tavistock Publications-Routledge.

## **GLOVER, JAMES (1882–1926)**

English psychoanalyst and physician James Glover was born in Lesmahagow, Lanarkshire, Scotland. Six years older than his well-known brother Edward, James was, after Ernest Jones, the most notable British (Scottish) psychoanalyst of his era. As he died prematurely from diabetes at the age of forty-four, after only eight years of training and practice of psychoanalysis, he left few publications. Had not Ernest Jones devoted eight pages of the *International Journal of Psychoanalysis* (volume 8, 1926) to his obituary, there would be little record of his life and the name of Glover would exclusively be associated with his younger brother.

James and Edward were the sons of Matthew Glover, country schoolmaster and academic, and Elizabeth Smith Shanks, who came of a farming family. There was a middle brother who died. James was regarded as the genius of the family and Edward as the more pedestrian. James received a fine Scottish

education, which stimulated and trained his intellect; throughout his life he maintained his knowledge of science and philosophy. At the same time, he was a writer of short stories and a great reader of literature.

James qualified as a physician and surgeon in Glasgow at the early age of twenty-one. As he was already in poor health, he undertook sea voyages and spent some years in Brazil where he practiced both medicine and surgery. After some ten years his health deteriorated further and he returned to Britain where he practiced chest medicine and ear, nose, and throat surgery.

His philosophical interests turned to psychology and to an interest in Freud. In 1918 he joined the Brunswick Square Clinic, the first psychotherapy center in the United Kingdom, founded by Julia Turner and Dr. Jessie Murray. They practiced an eclectic form of psychotherapy, influenced by Pierre Janet and Dejerine. James underwent a “pseudo-analysis” with Julia Turner and quickly became co-director of the clinic with her after the illness and death of Dr. Murray. He was very active in training psychotherapists at the clinic and was in charge of the rehabilitation of resident patients. But his skeptical and enquiring mind and strict scientific and philosophical outlook soon made him dissatisfied with eclectic psychotherapy and he decided to become a psychoanalyst. In 1920 he attended the Hague Congress of Psychoanalysis and went on to Berlin for some months of analysis with Karl Abraham and returned to him for more analysis the following year. At this time he insisted that psychoanalysis should be the only form of psychotherapy at the Brunswick Square Clinic and persuaded both the patrons and the staff to close the clinic and to transfer its funds and activities to the Psychoanalytic Society. Jones writes that he displayed tact combined with a steel-like resolution in order to get his way. Amongst the psychoanalysts who were drawn to psychotherapy through the Brunswick Square Clinic were Sylvia Payne, Mary Chadwick, Ella Sharpe, Nina Searle, Susan Isaacs, Iseult Grant-Duff, Marjorie Brierley and the Jungian Constance Long.

Glover became an associate member of the newly formed Psychoanalytic Society in 1921, full member 1922, and in 1924 was appointed to the council. He arranged the transfer of the International Library of Psychoanalysis to the Hogarth Press of Leonard and Virginia Woolf. Glover was untiringly active in the Psychoanalytic Society, training, lecturing (particularly on anxiety states), and establishing the clinic of the society, and was its assistant director.



Glover was a fine lecturer and a fierce polemicist, a trait shared with his brother Edward. He was appointed chair of the medical section of the British Psychological Society, which was the meeting ground for psychotherapists of different persuasions. One of his few published papers is his contribution to a symposium “The conception of sexuality” (1925), in which he savagely criticized the contribution of J.A. Hadfield, a leading figure at the Tavistock Clinic. Reading his paper gives a vivid insight into the quality of Glover’s mind; he was described by Ernest Jones as lucid, ironic, as a master of metaphor, and a searcher for truth.

Glover hesitated to publish and had to be persuaded. He gave a paper “Notes on an unusual form of perversion”, at the 1924 Salzburg Congress and it was published in *The International Journal of Psychoanalysis*. He gives a clear and rigorous account of the analysis of his patient who was an alcoholic fetishist. Glover showed that there was a marked oral fixation underlying the genital oedipal level: the attitude to the maternal nipple was as a source of pleasure and a focus for oral sadism. He wished to take revenge on the nipple for his weaning and for his mother’s betrayal of him through her genital relationship to her husband. The patient’s fetishist behavior involved shoes, which represented both the maternal phallus and a disgust for smell, which was a fecal displacement. Particularly interesting is his discussion of the fetish having been established at a phase when clear self-object differentiation had not been established.

Glover died of severe diabetes: Ernest Jones wrote that this was “an inestimable loss” to psychoanalysis.

MALCOLM PINES

See also: British Psycho-Analytical Society; Glover, Edward; Great Britain.

### **Bibliography**

- Glover, James. (1924). Notes on an unusual form of perversion. *International Journal of Psychoanalysis*, 8, 10–24.
- (1925). Contribution to a symposium on the conception of sexuality. *British Journal of Psychology*, 5, 3.
- Jones, Ernest. (1927). James Glover, 1882–1926. *International Journal of Psychoanalysis*, 8, 1–9.
- Pines, Malcolm. (1991). The development of the psychodynamic movement. In Berios, G.E.; and Freeman H. (Eds.). *150 years of British Psychiatry 1851 to 1991*. London: Gaskell-Royal College of Psychiatrists

## GOETHE AND PSYCHOANALYSIS

Johann Wolfgang von Goethe (born August 28, 1748; died March 22, 1832), poet and dramatist, dominated the German literary scene of his time. The *Aufklärung*, *Sturm und Drang*, of which he is the principal representative along with Johann Herder and Friedrich von Schiller, the German classicism he embodied along with Schiller, and German romanticism have all been referred to by Heinrich Heine as “Goethean.” He is one of the principle sources of Freudian thought.

Freud noted Goethe’s scientific interests (Freud, 1930e). After reading the poem, “Hymn to Nature”—then attributed to Goethe but in reality written by Georg Christoph Tobler, a Swiss pietist—Freud decided to enter medical school, and according to Ludwig Binswanger, throughout his work remained faithful to nature’s “mythical essence.” A theoretician of evolution fifty years before Darwin, Goethe inspired Freud, as shown by the “sheep’s head” dream, where the dreamer’s associations make reference to Goethe’s research on the intermaxillary bone of the sheep.

Goethe introduced the ideas of Spinoza—another of Freud’s models—into Germany, and Freud often quoted Goethe’s maxim: “The best of what you know/ You could not tell your students,” which reflected the need for dissimulation imposed by the revelation of essential truths.

Freud often quoted Goethe’s *Faust*; speaking through the devil, he assumed his role as (metapsychological) sorcerer in the creation of his work. He also referred to the “eternal feminine” and the “Mothers,” using the poet’s words to flesh out his conception of the representation of the mother and woman. He made use of a number of Goethe’s lines, such as “in the beginning was the Deed,” (for example, 1912–13a, p. 161) and “What thou hast inherited from thy fathers, acquire it to make it thine” (e.g., 1912–13a, p. 158n).

Goethe was a secret advisor to the Duke of Saxe-Weimar and had Johann Fichte and representatives of the first phase of German romanticism appointed to the University of Jena. Nearly contemporary with the universalism of the Enlightenment and the French Revolution, he opposed a number of romantic ideas, even though the concept of *Naturphilosophie* was a logical outcome of his scientific research. In Goethe’s work, the word *Trieb*—which became a core concept in psychoanalysis—assumes the meaning of instinct,

need, and mental impulse, *Bildungstrieb* being the secret force that animates living creatures. The model of the *Urphänomen* influenced the model of the primal in mental life (Vermorel, 1995).

Goethe was one of Freud's principal models and he quotes him a hundred and ten times, according to the Concordance. He even shows up in Freud's dreams as a familiar character, like his family and friends. Freud identified with this creative genius, who, like him, was coddled during childhood by his mother but deeply wounded by the death of family members. According to Alain de Mijolla (1981), because he often held his father in low esteem, Freud created a double of his grandfather Schlomo in the idealized figure of the sage of Weimar.

In his acknowledgments for receiving the Goethe prize, Freud recognized that the poet had emphasized Eros in mental life and appreciated the value of dreams. He said his inspiration for the term "psychoanalysis" came from the "chemistry" found in the *Elective Affinities* (the alchemy to which Goethe was introduced as a young man). He went so far as to turn him into a precursor of psychoanalysis, for having described in *Iphigenia* a kind of spiritual cure, and using conversation to heal a mental symptom experienced by Mrs. Herder (Freud, 1930e).

HENRI VERMOREL

*See also:* Act/action; Eissler, Kurt Robert; Freud-Nathanson, Amalia Malka; Goethe Prize; *On Dreams*; *On Transience*; Vienna, University of; Witch of Metapsychology, the.

### Bibliography

Freud, Sigmund. (1917b). A childhood recollection from *Dichtung und Wahrheit*. *SE*, 17: 145–156.

———. (1930e). Address delivered in the Goethe Haus at Frankfurt. *SE*, 21: 208–212.

Goethe, Johann Wolfgang von. (1992). *Faust, a tragedy, part one*. (Martin Greenberg, Trans.). New Haven, CT: Yale University Press. (Original work published 1808)

———. (1998). *Faust, part two*. (Martin Greenberg, Trans.). New Haven, CT: Yale University Press. (Original work published 1883)

Hachet, Pascal. (1995). *Les psychanalystes et Goethe*. Paris: L'Harmattan.

Vermorel, Henri. (1995). La pulsion, de Goethe et de Schiller à Freud. In H. Vermorel et al. (Eds.), *Freud, Judéité, Lumières et Romantisme* (pp. 133–149). Lausanne: Delachaux & Niestlé.

## GOETHE PRIZE

The Goethe prize was awarded by the city of Frankfurt to Sigmund Freud on August 28, 1930 in Frankfurt-am-Main. The prize, instituted in 1927, was awarded annually on August 28, the anniversary of the birth of Johann Wolfgang von Goethe. The sum of ten thousand Deutsche Marks was awarded to individuals "whose creative activity served to honor the memory of Goethe." Before Freud the prize had been given to Stefan George (1927), Albert Schweitzer (1928), and Leopold Ziegler (1929).

In 1927 Heinrich Meng and Stefan Zweig had begun a promotional campaign to propose Freud for the Nobel Prize. Members of the Frankfurt Psychoanalytic Institute (1929–1933), especially Heinrich Meng, also worked to ensure that Freud was awarded the Goethe prize. Because of his poor health, Freud, then seventy-four years old, was unable to accept the prize in person and sent his daughter Anna Freud to Frankfurt for the awards ceremony (1930d).

The award of the Goethe prize by Frankfurt in 1930 was considered by Freud to be the culmination of his public life. Discussions by the award committee appeared to idealize psychoanalysis, but in fact it was criticized. Among the adversaries of psychoanalysis there was a general refusal to accept psychoanalysis and a converse movement to idealize Goethe, which, given the regressive nature of German society of the time, was soon to become a permanent characteristic. A few years later, in 1933, Freud's writings were burned by the National Socialists in Frankfurt and in other German cities.

The reaction of the media to the award simply repeated the controversy that divided the award committee. The periodical *Die Psychoanalytische Bewegung* (1930), contains a review of the event in German.

THOMAS PLÄNKERS

*See also:* Freud Anna; Germany; Goethe and psychoanalysis; Meng, Heinrich.

### Bibliography

Freud, Sigmund. (1930d). Letter to Dr. Alfons Paquet. *SE*, 21: 207–207.

Paquet, Alfons. (1930). Zum Goethepreis 1930. Rede im Südwestdeutschen Rundfunk am 28.8.1930. In *Die Psychoanalytische Bewegung*. p. 426–430.

Plänkers, Tomas. (1993). Vom Himmel durch die Welt zur Hölle. Zur Goethe-Preisverleihung an Sigmund Freud im Jahre 1930. *Jahrbuch für Psychoanalyse*, 30, p. 167–180.

———. (1996). Die Verleihung des Frankfurter Goethe-Preises an Sigmund Freud 1930. Die Sitzungsprotokolle des Goethe-Preiskuratoriums. In Tomas Plänkers, et al., *Psychoanalyse in Frankfurt a. M. Zerstörte Anfänge, Wiedernäherung und Entwicklungen* (p. 254–331). Tübingen: Diskord.

## GOOD-ENOUGH MOTHER

The “good-enough mother” is a mother whose conscious and unconscious physical and emotional attunement to her baby adapts to her baby appropriately at differing stages of infancy, thus allowing an optimal environment for the healthy establishment of a separate being, eventually capable of mature object-relations.

Evolving slowly, and underpinning Donald Winnicott’s theory of early integration, personalization and object-relating, this concept includes the “ordinary devoted mother” (1949), and “the good-enough environment”. It first appears clearly in Winnicott’s “Mind and its Relation to the Psyche-Soma” (1949).

Winnicott’s emphasis on the particular need for maternal sensitivity begins in his paper “The Observation of Infants in a Set Situation” (1941), and is referred to repeatedly in his work. His statement, “There is no such thing as a baby” implies that without a mother, an infant cannot exist. He describes “primary maternal preoccupation” (1956), the psychophysiological preparedness of a new mother for motherhood, as a special phase in which a mother is able to identify closely and intuitively with her infant, in order that she may supply first body-needs, later emotional needs, and allow the beginnings of integration and ego-development.

The good-enough mother is described as responding to the infant’s gesture, allowing the infant the temporary illusion of omnipotence, the realization of hallucination, and protection from the “unthinkable anxiety” (primitive agonies) that threatens the immature ego in the stage of “absolute dependence.” Failure in this stage may result, ultimately, in psychosis.

As the infant develops, the good-enough mother, unconsciously aware of her infant’s increasing ego-integration and capacity to survive, will gradually fail to be so empathic. She will unconsciously “dose” her failures to those that can be tolerated, and the infant’s

developing ego is strengthened, the difference between “me” and “not-me” clarifies, omnipotence is relinquished, a sense of reality begins to emerge, mother can be increasingly seen as a separate person, and “the capacity for concern” can develop. Failure in this stage may result in the formation of a “false self.”

Winnicott describes how the capacity to be alone can develop out of the experience of the infant of being alone in the presence of another. Ego-immaturity is balanced by ego-support from mother, and this ego-support is in time internalized, so that aloneness is tolerable (1958).

Many writers approach environmental failure (Fairbairn, Kohut, Balint, and others); however, few describe the optimal situation in health as described by Winnicott. Winnicott is accused of romanticism, idealism and optimism in his description of the mother whose adaptation is so exquisite, and of “blaming the mother” when things go wrong. It is important in reading his work to realize the lack of moralism he evinces. Winnicott certainly regrets the failure of those mothers who cannot reach the state of being “good-enough,” but acknowledges that this state arises out of their own early relationships, and he emphasizes repeatedly the strength of innate maternal capacity.

JENNIFER JOHNS

*See also:* False self; Handling; Holding; Maternal care; Object; Self (true/false); Transitional object, space; Winnicott, Donald W.

### Bibliography

Winnicott, Donald W. (1956). Primary maternal preoccupation. In *Collected papers, through paediatrics to psychoanalysis* (pp. 300–305). London: Tavistock Publications, 1958.

———. (1958). Mind and its relation to the psyche-soma. In *Collected papers, through paediatrics to psychoanalysis* (pp. 243–54). London: Tavistock Publications. (Reprinted from *British Journal of Medical Psychology*, 27, (1954), 201–209.)

———. (1958) The observation of infants in a set situation. In *Collected papers, through paediatrics to psychoanalysis* (pp. 52–69). London: Tavistock Publications. (Reprinted from *International Journal of Psycho-Analysis*, 22 (1941), 229–249.)

———. (1965). The capacity to be alone. In *The maturational processes and the facilitating environment* (pp. 29–36). London: Hogarth Press and the Institute of Psycho-Analysis. (Reprinted from *International Journal of Psycho-Analysis*, 39 (1958), 416–420.)

**GÖRING INSTITUTE.** *See* Deutsches Institut für Psychologische Forschung und Psychotherapie (Institut Göring)

## GÖRING, MATTHIAS HEINRICH (1879–1945)

Matthias Heinrich Göring, a German physician, psychiatrist, and Nazi, was born on April 5, 1879, in Düsseldorf, Germany and died in 1945 in captivity in Poznan, Poland.

He earned a doctorate in law at Freiburg/Breisgau in 1900 and a doctorate in medicine at Bonn in 1907. Specializing in psychiatry and neurology, in 1923 Göring set up practice as a *Nervenarzt* in Elberfeld and subsequently underwent a training analysis with Adlerian Leonhard Seif in München. In 1928 he established an educational counseling service in Elberfeld and in 1929 founded a study group of psychotherapy in Wuppertal.

Like fellow Adlerians Seif and Fritz Künkel, Göring placed an emphasis upon “community feeling,” to which he added German patriotism and Christian pietism. He was therefore critical of psychoanalysis for its alleged materialism and pansexualism.

Göring’s significance in the history of psychoanalysis stems from his career after 1933. His position as leader of organized psychotherapy in Nazi Germany stemmed from the fact that he was an elder cousin of Nazi boss Hermann Göring. In part to protect the fledgling institution of psychotherapy against Nazi medical activists and university psychiatrists, Göring (who joined the Nazi party in 1933) preached against “Jewish” psychoanalysis and supervised the exclusion of Jewish psychoanalysts from his society and institute.

In 1934 Göring assumed leadership of the German General Medical Society for Psychotherapy and from 1936 to 1945 was director of the German Institute for Psychological Research and Psychotherapy in Berlin. In 1938 he presided over the destruction of the Vienna Psychoanalytic Institute and the dissolution of the German Psychoanalytic Society, although also protecting and employing psychoanalysts August Aichhorn, Felix Boehm, and Carl Müller-Braunschweig.

At the German Institute for Psychological Research and Psychotherapy in Berlin and at branches elsewhere in Germany and in Vienna, however, non-Jewish psychoanalysts continued to practice, study, and train. Göring himself allegedly expressed appreciation for the expertise of the Freudians, who were especially active within the Berlin outpatient clinic. Göring’s wife Erna was in analysis with Werner Kemper and his son Ernst underwent a training analysis with Carl Müller-Braunschweig. Outpatient director and psychoanalyst John Rittmeister, however, fell victim to charges of espionage and was executed by the Nazis in 1943.

The legacy for psychoanalysts in Germany of the institutionalization of psychotherapy that Göring occasioned during the Third Reich has been one of both professional advancement and internecine ethical debate.

GEOFFREY COCKS

*See also:* Allgemeine Ärztliche Gesellschaft für Psychotherapie; Berliner Psychoanalytische Poliklinik; Deutsches Institut für Psychologische Forschung und Psychotherapie (Institut Göring); France; Germany; Psychopathologie de l'échec (Psychopathology of Failure).

### Bibliography

- Cocks, Geoffrey. (1985). *Psychotherapy in the Third Reich: The Göring Institute* (2nd ed). New York: Oxford University Press.
- Lockot, Regine. (1985) *Erinnern und Durcharbeiten : zur Geschichte der Psychoanalyse und Psychotherapie im Nationalsozialismus*. Frankfurt am Main: S. Fischer.
- . (1994). *Die Reinigung der Psychoanalyse : die deutsche psychoanalytische Gesellschaft im Spiegel von Dokumenten und Zeitzeugen (1933–1951)*. Tübingen: Diskord.

**GRADIVA.** *See* Delusions and Dreams in Jensen’s “Gradiva”

**GRAF-FREUD, REGINA DEBORA (ROSA).** *See* Freud, Sigmund (siblings)

## GRAF, HERBERT (1904–1973)

Herbert Graf is broadly known in psychoanalysis by the name of “Little Hans.” Born on April 10, 1904 in Vienna, he died on April 5, 1973 in Geneva.

Graf was the Stage Director at the Metropolitan Opera in New York 1936–1960, and Director of the Grand Theatre in Geneva (1965–1973). He also authored several books on opera production in America.

The son of Max Graf, musicologist and critic, and Olga Graf (nee Hoenig), apparently a one-time patient of Freud’s, Herbert Graf grew up in the avant-garde intellectual atmosphere of fin de siècle Vienna. His godfather was Gustav Mahler. He describes, in a four part interview with Francis Rizzo later in life, how he “invented” his study program in order to become an opera director, for which there was at that time no prescribed curriculum.

In 1922 Freud published a postscript to “Analysis of a Phobia in a Five-year old Boy” in which he describes a visit from “Little Hans” when he was a young man. Graf himself refers to this visit in the Rizzo interviews and reports that he had no recollection of the treatment until he came across Freud’s paper in his father’s study. Several place names that Freud had not altered led him to believe that the article referred to him. He sought Freud out in Berggasse 19 and the meeting is described in Freud’s publication.

Graf’s publications were not in the field of psychoanalysis. The interviews with Rizzo are interesting for the light they shed on the attitudes towards Freud’s theories amongst intellectuals in Vienna in the early part of the twentieth century. Graf’s later biography had no relevance to psychoanalysis. As “Little Hans” he was of fundamental importance. His treatment was the very first example of a child analysis, although an unusual one, as it was carried out by his father under Freud’s “supervision.”

VERONIKA MÄCHTLINGER

See also: “Analysis of a Phobia in a Five-year-old Boy” (Little Hans); Graf, Max.

### Bibliography

Freud, Sigmund. (1909b). Analysis of a phobia in a five-year-old boy. *SE*, 10: 1–149.

———. (1922c). Postscript. *SE*, 10: 148.

Rizzo, Francis. (1972). Memoirs of an invisible man; Herbert Graf recalls a half-century in the theater: a dialogue with Francis Rizzo, interview, with 12 illustrations and 2 sketches. *Opera News* 36, part I, 5 Feb. 1972, p. 24–28 ; part II : 12 Feb. 1972, p. 26–29 ; part III : 19 Feb. 1972, p. 26–29 ; part IV : 26 Feb. 1972, p. 26–29.

## GRAF, MAX (1873–1958)

Max Graf, a composer and music critic, the father of “Little Hans,” was born October 1, 1873, in Vienna, where he died on June 24, 1958.

The son of Joseph Graf, a Jewish writer and editor, he was educated in Vienna and Prague. After 1891 he studied at the law school of the University of Vienna but devoted most of his time to music and it was his intention to become a composer, according to Louis Rose (1986). He finished his legal studies in 1896 but devoted much of his time to music composition and criticism, and regularly took part in meetings of the literary group *Jung-Wien*. From 1902 to 1938 he taught the history of music and musical aesthetics at the Vienna Academy of Music, where he was appointed professor in 1909.

Graf met Sigmund Freud in 1900 and his wife, Olga Graf (born Olga Hoenig), from whom he separated a few years later, was probably a patient of Freud’s. Within the psychoanalytic movement he is known for being the father of “Little Hans,” Herbert Graf, who was born in 1903. It was Max who supplied Freud with the material for his paper “The Analysis of a Phobia in a Five-Year Old Boy” (1909b).

At the end of 1904, he took part in sessions of the Wednesday Psychoanalytic Society and, in December 1907, wrote an essay entitled “Methodik der *Dichterspsychologie*” (Methodology of the Psychology of the Poet). In early 1906 Freud wrote a short text on a somewhat unexpected topic, “Psychopathische Personen auf der Bühne” (Psychopathic Characters on the Stage). The text was never published in German, but Graf, to whom Freud had given the manuscript, kept it and had an English translation published (1942a [1905–1906]).

In 1909 Graf settled in Paris as a correspondent for the *Frankfurter Zeitung* and translated Romain Rolland into German. “In 1910–1911 he gave up all work

with the Society. His book on the psychology of creativity appeared in 1910 and his pamphlet on Wagner in 1911. In February 1909 Freud had asked him to prepare an essay on ‘Mozart and his Relation to Don Juan,’ but Graf did not follow up on the idea. He officially withdrew in 1913” (Rose, 1986). On the list of members of the Vienna Psychoanalytic Society for October 1913, his name is crossed off.

Graf emigrated to the United States in 1938 and taught until 1947 at the New School for Social Research in New York, where, in 1940, he created the first seminars in music criticism. He was a guest professor at the Carnegie Institute of Technology in Pittsburgh and at Temple University in Philadelphia. In 1947 he returned to Austria and taught music criticism at the Mozarteum in Salzburg and elsewhere. In 1953 his autobiography, *Jede Stunde war erfüllt: Ein halbes Jahrhundert Musik- und Theaterleben* (Every Minute Filled: A Half-Century in Music and Theater), was published in Vienna, where he died in 1958.

ELKE MÜHLEITNER

See also: “Analysis of a Phobia in a Five-year-old Boy” (Little Hans); Applied psychoanalysis and the interaction of psychoanalysis; Graf, Herbert; *Minutes of the Vienna Psychoanalytic Society*.

### Bibliography

Graf, M. (1911). *Richard Wagner im “Fliegenden Holländer,” Ein Beitrag zur Psychologie des künstlerischen Schaffens*. Leipzig-Vienna: F. Deuticke.

———. (1942). Reminiscences of Professor Sigmund Freud. *Psychoanalytic Quarterly*. 11, p. 465–476.

———. (1947). *From Beethoven to Shostakovich: The Psychology of the Composing Process*. New York: Philosophical Library.

Mühlleitner, Elke. (1992). *Biographisches Lexikon der Psychoanalyse (Die Mitglieder der Psychologischen Mittwoch-Gesellschaft und der Wiener Psychoanalytischen Vereinigung 1902–1938)*. Tübingen: Diskord.

Rose, Louis. (1986). *The psychoanalytic movement in Vienna: Towards a science of culture*. Dissertation, Princeton University.

## GRANDIOSE SELF

The grandiose self, described and developed as a normal narcissistic configuration by Heinz Kohut in 1971

in *The Analysis of the Self*, corresponds to or replaces the “purified pleasure-ego” posited by Sigmund Freud: The subject, center of the world, expels what is unpleasurable and preserves what is pleasurable. In theory, the instinctual grandiose self is integrated into the self to form the nucleus of the ambitions (strivings), but it cannot constitute itself or be the object of fixations, repression, or splitting.

The grandiose self, also called the narcissistic self, first appeared in Kohut’s work in 1964. A description of an aspect of the narcissistic personality, it acquired a metapsychological status in Kohut’s 1971 book.

From a developmental point of view, the infant attempts to restore narcissistic perfection by establishing narcissistic configurations, among them the grandiose self, a structure invested with energy that is rooted in exhibitionist part-instincts. In narcissistic pathology, the activity of the grandiose self explains the intensity of the demand for attention; if it is repressed, no source is available to nourish the reality-ego, which is characterized by a lack of self-esteem, feelings of inferiority, and a tendency toward depression. In Kohut’s *The Restoration of the Self* (1977), the grandiose self is the pole of the self that draws its strength from the self objects’ responses to mirroring needs.

The notion is related to mirror transference.

Initially instinctual, the grandiose self was desexualized with Kohut’s generalized self psychology advanced in 1977.

AGNÈS OPPENHEIMER

See also: Self psychology.

### Bibliography

Kohut, Heinz. (1971). *The analysis of the self*. New York: International Universities Press, 1971.

———. (1977). *The restoration of the self*. New York: International Universities Press

## GRANOFF, WLADIMIR ALEXANDRE (1924–2000)

Wladimir Alexandre Granoff, a French psychiatrist and psychoanalyst, was born September 7, 1924, in Strasbourg, and died in Neuilly-sur-Seine on February 2, 2000.

His family, part of the Russian intelligentsia, had moved to Alsace after emigrating from Russia. Young Granoff attended secondary school in Strasbourg. During the war, as a refugee in Nîmes, he discovered Freud's work in the local library. He began studying medicine and psychiatry in Lyon and continued his education in Paris.

With the Société Psychanalytique de Paris (Paris Psychoanalytic Society) he began a training analysis with Marc Schlumberger; Maurice Bouvet and then Jacques Lacan directed his group control analysis, and Francis Pasche his individual control analysis. In 1953 he began organizing the student rebellion at the Institut de Psychanalyse with Serge Leclair and François Perrier, whom he followed during the June 1953 split. The three men were later referred to as the "Troika." After their secession they participated actively in the Société Française de Psychanalyse (SFP) (French Society for Psychoanalysis), founded in 1953, leading seminars on clinical psychoanalysis together and working to ensure the organization's admission into the International Psychoanalytic Association (IPA). During a colloquium on female sexuality organized by the SFP in September 1960 in Amsterdam, Granoff and François Perrier presented a report on "Le problème de la perversion chez la femme et les idéaux féminins," which reopened the question of female sexuality (*La Psychanalyse*, 1964).

He played an important role in negotiations with the IPA (Pierre Turquet, Max Gitelson) because of his multilingualism (he spoke Russian, German, English, and French). In 1963, together with his friend Victor Smirnoff, he prepared a "Histoire de la psychanalyse en France," in order to convey to the Anglo-American psychoanalytic community the originality and specificity of psychoanalysis in France. The article was mimeographed and translated into English, but remains unpublished at this time. Despite these efforts, Granoff sensed that their request would be rejected and that Lacan would never be admitted to the IPA. He also felt he himself had been betrayed by Lacan. So, in 1964, he helped found the Association Psychanalytique de France (French Psychoanalytic Association) and abandoned any further involvement in institutional politics, refusing even to attend IPA congresses.

After years of absence from public life, he presented a paper in 1973–1974, "Filiations, l'avenir du complexe d'Œdipe," a psychoanalytic interpretation of the

history of psychoanalysis, characterized by a return to Freud's writings. In 1974–1975 he gave another talk on "La pensée et le féminin." These presentations were contemporaneous with those given by François Perrier and it was at this time that the two men renewed their former friendship.

He was one of the first to introduce Sándor Ferenczi in France and held a conference in 1958 entitled "Ferenczi: faux problème ou vrai malentendu" (published in *La Psychanalyse*, 1961). In 1983 he published, together with philosopher Jean-Michel Rey, *L'Occulte, objet de la pensée freudienne*, in which he investigated Freud's interest in telepathy.

His withdrawal from organizational work did not mean retirement from active life, and Granoff always maintained relations with French Lacanians and foreign colleagues. Because of his broad exposure to European culture and his Slavic background, he was perhaps the most cosmopolitan, the most international French psychoanalyst of his generation. His work—in large part appearing in individual articles—focused on Freudian practice as well as the problems of translating and transmitting psychoanalysis.

JACQUES SÉDAT

*See also:* Association psychanalytique de France; Femininity; France; Psychoanalytic filiations; Société française de psychanalyse; Telepathy.

### Bibliography

- Granoff, Wladimir. (1975). *Filiations. L'avenir du complexe d'Œdipe*. Paris: Minuit.
- . (1976). *La pensée et le féminin*. Paris: Minuit.
- Granoff, Wladimir, and Perrier, François. (1964). Le problème de la perversion chez la femme et les idéaux féminins. *Psychanalyse*, 7, 141–199.
- . (1979). *Le désir et le féminin*. Paris: Aubier.
- Granoff, Wladimir, and Rey, Jean-Michel. (1983). *L'Occulte, objet de la pensée freudienne*. Paris: Presses Universitaires de France.

---

## GRAPH OF DESIRE

The Graph of Desire is a schema, or model, that Jacques Lacan began developing in his seminar on *The Formations of the Unconscious* (1957–58). It achieved

its definitive form in his essay “Subversion of the Subject and the Dialectic of Desire in the Freudian Unconscious” (1960/2004). Its four successive stages represent the constitution of the human subject and his desire. Nevertheless, Lacan never intended it to describe the genetic stages of a biological development. Rather, it represents the “logical moments” of the birth of a speaking subject.

Lacan starts with what he calls the “quilting point” (where an upholsterer attaches a button to a sofa or mattress to prevent the batting from moving around) a kind of looping by which the signifying chain of the parental Other’s “discourse”—not to be understood here as merely verbal, of course—intersects with the baby’s expressions of need (See Figure 1).

This pressure of need is represented by a retrograde trajectory beginning at delta ( $\delta$ ). In the course of its reverse looping, this line intersects at two successive points the vector  $S \rightarrow S'$ , which represents the chain of the Other’s discourse. Because they travel in opposite directions, the two trajectories carry out this double intersection in a retroactive manner that calls to mind Freud’s concept of “deferred action.” For Lacan, the point of intersection on the right,  $A$ , represents the “treasure trove of signifiers” (p. 292), which is Lacan’s definition of the Other as the “locus” of the signifying battery on which the subject depends. On the left, the other point,  $s(A)$ , represents the moment at which a meaning is produced in the heart of the Other, which henceforth makes it a sign for the infant.

This first stage of the graph forms a “circuit” of vectors that first follows the chain of the Other’s

discourse, from  $s(A)$  to  $A$ , and then returns, from  $A$  to  $s(A)$ , along the path of the baby’s biological impulses. In this circularity, everything comes back to the signifying structure of the Other’s discourse. The demand of the newborn must conform the Other’s “code” in order to be understood.

In spite of this apparently closed circularity, Lacan also situates the constitution of the ego ideal at this level. By grasping upon an insignia of the Other’s parental power,  $s(A)$ , the child anticipates its own future access to any power whatsoever. From then on, the ego ideal,  $I(A)$ , is inscribed at the endpoint of trajectory delta, as an anticipated function that the child can attain in relation to the parent.

The process where the ego is constituted makes up the second stage of the graph. A right-to-left vector goes from the specular image,  $i(a)$ , to the constitution of the ego,  $m$  (Figure 2). This vector is essentially imaginary, which means that it belongs to the register of spatial-corporeal representation, and it is grafted as a short circuit onto the delta trajectory, which represents the pressure of need.

From then on, a second circuit can be taken by returning along the signifying chain,  $S \rightarrow S'$ . This return circuit, by which the constitution of the ego is implicated in the discourse of the Other, might constitute in itself an impasse, from which no subject could extricate himself. And this is where Lacan made one of his specific contributions to psychoanalysis by emphasizing the intrinsic doubling of the Other’s discourse.

We have seen that effects of meaning are manifested in the Other,  $s(A)$ , where they are interposed between

FIGURE 1

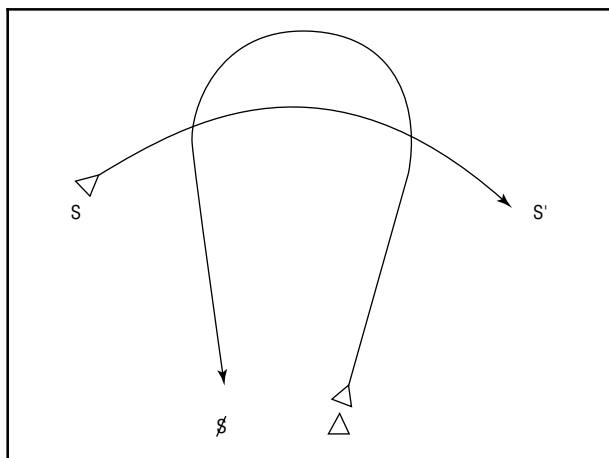
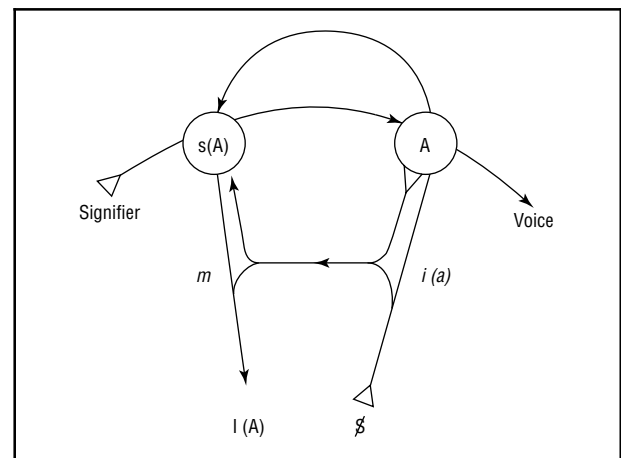
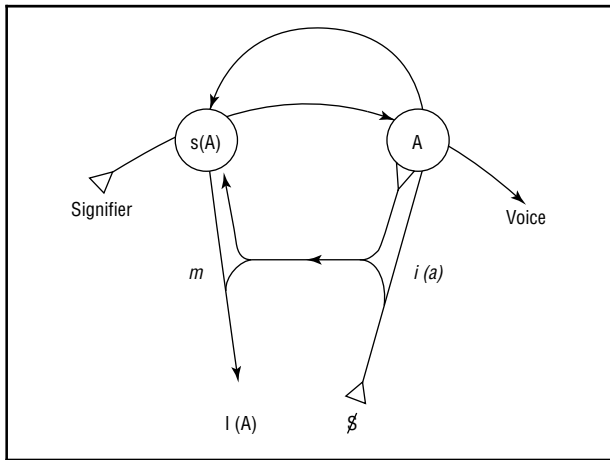

FIGURE 2





**FIGURE 3**



the needs of the baby and certain signals and statements coming from the mother. The baby comes to feel capable of provoking these maternal manifestations, and at the same time develops a paranoid tendency to interpret their intentionality when they appear.

Lacan developed an account of this essential phenomenon on the basis of certain linguistic facts that led him to distinguish, beyond the subject of the *statement* evident in the parental discourse, a more or less obscured subject of the *enunciation*. This implied that quite another dimension of unconsciousness was possible (Figure 3).

The intentionality that is assumed to exist in the manifestations of the Other causes the child to ask—*What does he want from me?* This question forms the basis of the first experience of anxiety (*Hilflosigkeit*). Given the fundamental mirroring nature of the imaginary relation that gives the ego substance, this paranoid question—*What does he want from me?*—returns in the form of a question addressed to the nascent subject—*What do you want?* (or “*Chè vuoi?*” as Lacan puts it). This form of address, characteristic of the superego leads to the upper stage of the graph, which it takes the form of a question mark rooted in A, the place of the Other. But the Other at this stage is still not in any way the “barred” by the symbolization of its possible absence and not yet marked by the incompleteness of its sexual identity. At this point the Other is still the all-embracing expression of the two parents merged into a single non-castrated parent figure. It is the perception of the mother’s lack of a penis that now plays the crucial role of representing the incompleteness of the maternal Other.

For the nascent subject, this is a transformational moment that leads to a recognition that the Other is desiring/lacking. From that moment on, the Other will be “barred,”  $S(\bar{A})$ , and submitted to the symbolic system of exchange that is instituted in the aftermath of the of the superego’s question (*Chè vuoi?*). It is from this point that we can conceive of the emergence of a subject in its own right. Lacan designates it with a barred S because of its fundamental dependence on a relation of at least two signifiers, one of which is necessarily the signifier of the lack in the Other—without which, Lacan said, no signifier would ever be able to represent a “person.”

This is what can be formalized in a fourth imaginary stage wherein the subject that is detached at the point of symbolization by the Other finds a way to represent itself as having a relation with the object of desire through an unconscious fantasy, as shown in the formula  $\$ \diamond a$ . The operation by which the Other is recognized as lacking is inscribed in a symbolic system of exchange that nevertheless includes a real “remainder” made up of objects that are detachable from the mother. These are the Freudian partial objects, which Lacan designates with a small *a*, that become part of the fantasy. Any persistent difficulty in symbolically marking the mother’s lack interferes with the constitution of the fantasy and leads to a failure in the process of subjectivation (Figure 4).

At the upper level of the graph, along the imaginary vector ( $d \rightarrow \$ \diamond a$ ), desire and fantasy maintain a relation similar to the one that at the lower level governed the constitution of the ego in relation to the image of the small other,  $i(a)$ . However, Lacan noted that these two imaginary stages are not in any way analogous to each other, since unconscious desire tends to present itself regularly to the ego as precisely what the ego does not want. The subject of the unconscious fantasy, in contrast to the ego, represents for Lacan “the ‘stuff’ of the *I* that is primally repressed” (p. 302). In treatment, this subject would be the analyst’s true interlocutor.

The two levels of the graph are modeled on a split that is structural in the human being (in Lacan’s terms *parlêtre*, or “speaking-being”). The first level, that of the statement and of specular relations of the ego, is prior to castration. It manifests a phallic-narcissistic logic where the nascent ego remains trapped in the circle of the Other’s all-importance. The upper level, on the other hand, has as its keystone the signifier of the lack in the Other,  $S(\$)$ , the guarantor of a discourse



For some years, having failed to obtain recognition in London, Jones had worked in Toronto and was one of the founders of the American Psychoanalytic Association. Though Jones must be regarded as an outstanding figure in the development of the psychoanalytic movement, he was not alone. David Eder gave the first paper on psychoanalysis to a medical audience in 1911 at a Congress of the British Medical Association; the audience left in disgust before he had finished speaking. Henry Butter Stoddart, a distinguished psychiatrist who became a convert to psychoanalysis, was better received. He gave a series of lectures titled "The New Psychiatry" in Edinburgh in 1915. There he found converts as well as opponents, the most significant of the former being George Robertson, Professor of Psychiatry at Edinburgh, who thereafter declared himself a Freudian. Stoddart, a stout, good-humored man, played a quiet yet important role in establishing psychoanalysis within psychiatry, through his well respected textbook "Mind and its Disorders."

In these early days psychoanalytic ideas were supported and propagated by important psychiatrists and psychologists who nevertheless maintained a critical attitude and did not become members of Jones's reformed British Psycho-Analytical Society (1919). Eder was accepted as, after some analysis with Sándor Ferenczi, he left Jung. Bernard Hart was significant both because of the respected position he held and as author of a textbook, "The Psychology of Insanity" (1912), which ran through many editions and was the principal textbook in support of psychoanalysis. The influential psychologist William McDougall, the research psychologist Sir Cyril Burt, the well-known clinician William Browne, all made Freud's ideas accessible to their professions. Perhaps the most brilliant figure was William Halse Rivers, psychiatrist, research psychologist, and anthropologist, who died prematurely in 1922. Rivers, along with other dynamically-minded psychiatrists, treated psychiatric casualties during World War One with a psychotherapy that was strongly influenced by psychoanalysis. Rivers's work and personality became well known through the autobiography of the poet Siegfried Sassoon who had been Rivers' patient during the war. The novelist Pat Barker used Rivers as a central character in her three novels about psychiatry and the First World War: *Regeneration*, *The Eye in the Door*, and *The Ghost Road* (London, Viking).

Psychoanalysis made great strides through the treatment of psychiatric cases during World War One, and

there were many chronic cases of these war casualties who had to be treated after the war. The Ministry of Pensions set up clinics to deal with these patients and their senior psychiatrist was the analyst David Forsyth. Attacks upon psychoanalysis came from many psychiatrists, notably a disciple of Hughlings Jackson, Charles Mercier. He attacked psychoanalysis as a German importation that would corrupt the minds both of doctors and of children. In his attacks he was supported by many other psychiatrists, amongst whom was the first Professor of Psychiatry in England, Shaw-Bolton. In a critical article, "The Myth of the Unconscious Mind" (1926), Shaw-Bolton stated that it had been a repugnant task to write but that psychoanalysis was an insidious poison being inserted into the minds of the young.

Jones reformed his Society more carefully and retained a strong control over its development for over two decades. Its outstanding supporters included the brothers James and Edward Glover. James, who died early, had been to Karl Abraham in Berlin for analysis and on his return dissolved the Brunswick Square Clinic which had been an important training institution for psychotherapy that was not psychoanalytic (Boll, 1962). Amongst its students who later became analysts were Mary Chadwick, Ella Freeman Sharpe, Nina Searl (a pioneer in child analysis), Iseult Grant-Duff and Marjorie Brierley, the last of whom was to become a very influential psychoanalytic theoretician.

In the 1920s psychoanalysis increased both in popularity and notoriety. The British Medical Association set up a committee to investigate and report on the subject of psychoanalysis following public disquiet over breakdowns and suicides said to be the result of psychoanalysis. This committee sat for three years and took evidence from both supporters and opponents of psychoanalysis. Ernest Jones represented psychoanalysis, and his impressive performance carried the day for the cause. The result was that the British Medical Association acknowledged psychoanalysis as an authentic form of treatment and determined that the term psychoanalysis should not be used for any other technique or theory than that of Freud. However, the committee did not record its support of psychoanalysis, solely its recognition.

In the 1920s and early 1930s the Psychoanalytic Society remained quite small and London remained the only training center. Some British analysts went to Vienna for analysis (the Stracheys, Money-Kyrle,

Riviere), some to Berlin (James and Edward Glover, Ella Sharpe), some to Budapest (David Eder). Interest grew in child analysis and Nina Searle began to write on this topic before Melanie Klein's arrival in 1926 at Jones's invitation. Klein was introduced through Alix Strachey who had gone to Berlin for further analysis with Abraham, being dissatisfied with her experience in Vienna with Freud. The correspondence between James and Alix Strachey gives a vivid picture of the two cities, Berlin and London, and their psychoanalytic communities.

It should be recognized that a distinct "English" school of psychoanalysis had begun to emerge. The distance from Vienna led to independent thinking; consideration was being given to the psychic consequences of bereavement and mourning following from the great number of casualties and bereaved families left by the war. This led to a consideration of object relations in addition to libidinal forces. John Carl Flugel, who held an academic position at London University, wrote the influential "Psychoanalysis of the Family," and John Bowlby researched the psychological and socially deprived backgrounds of juvenile delinquents. Donald Winnicott applied his extensive experience as a pediatrician to child analysis.

Melanie Klein made a powerful impact in Britain through her writings on early psychic development. She was supported by Susan Isaacs, Joan Riviere, Ernest Jones and others, although many analysts considered her ideas to be unsystematic and overly speculative. Among them, her clearest critic was Marjorie Brierley. Ronald Fairbairn, working in isolation in Edinburgh, was considerably influenced by Klein, and in turn Melanie Klein recognized that she also learned from him; impressed by his work on the schizoid personality she added "schizoid" to her "paranoid" early infantile stage, hence "paranoid-schizoid." Fairbairn was the strongest revisionist of psychoanalytic theories, establishing a full object relationship theory.

Jones continued to be the dominant figure in British psychoanalysis, as a result both of his writing and his personality. Influenced by Melanie Klein's exploration of early psychic development, he wrote on female sexuality in a way that Freud perceived as a challenge both to himself and to his daughter Anna. Jones tried to achieve a balance between the innovative British work and the more conservative Viennese mode, instituting a series of exchange lectures in an attempt to build bridges.

Edward Glover was Jones's close collaborator and for many years the presumptive next president of the Society. He produced the first enquiry into the theories and practices of psychoanalysis by issuing a questionnaire to members of the British Society which later he elaborated into his authoritative textbook on the technique of psychoanalysis. Though Glover had supported Melanie Klein for some years, later he strongly opposed her, and for this reason found himself against strong opposition when preparing to succeed Jones as president.

British psychoanalysis was dramatically changed by the flight of Sigmund and Anna Freud and their supporters to London in 1938. It is not pleasant to find it on record that Melanie Klein thought it unfortunate that the Freuds had come to London as it would prejudice her intellectual hold on the Psycho-Analytic Society. Indeed, conflict soon broke out between the Viennese and the supporters of Melanie Klein which in wartime led to the famous "Controversial Discussions" that set the scene for the tripartite division of training in the British Psycho-Analytical Society after the war, the three groups of Kleinians, Freudians and the Middle, later Independent Group. This group consisted of those who did not wish to be identified with either of the warring camps. Influential teachers during this period included: for the Klein Group, Susan Isaacs, Joan Riviere, Paula Heimann, Roger Money-Kyrle; for the "Middle Group"; Ella Freeman Sharpe, James Strachey, Sylvia Payne, Donald Winnicott, William Gillespie, Marjorie Brierley, and later Michael Balint; for the Anna Freud Group were Kate Friedlander, Ilse Hellman, and Willie Hoffer. Anna Freud virtually retired from the British Psycho-Analytical Society to build her own training center in child analysis at the Hampstead Child Therapy Clinic, though on the international scene she retained her pre-eminence in psychoanalytic theory.

British psychoanalysis has been regarded as leading the way in child analysis. This is due to several factors. The Hampstead Child Psychotherapy Clinic provided thorough training in child and adolescent analysis, as systematically organized by Anna Freud and her close collaborators. Research initiated by Joseph Sandler on the Hampstead Index (representing the Clinic's collection and collation of clinical experience) has led to several important publications. Anna Freud's concept of "developmental lines" has been a significant clarification in the study of child development. Melanie

Klein's theories have had a major impact and many child analysts have adopted her theories. The training in infant observation and child analysis at the Tavistock Clinic is largely Klein-oriented. Some of her ideas have eventually been partly accepted by those who previously opposed them, including Anna Freud's followers. Klein retained a stronghold on the writings of her followers, which eventually led Paula Heimann to leave her group. In contrast to Anna Freud, Klein did not develop a systematic training in child analysis, though her influence on the Tavistock training is noticeable. Donald Winnicott's writings represent a distinct and different viewpoint. His vast experience as a pediatrician and his acute observational powers led him to the concepts of transitional space and transitional object, tracing the infant's move away from total dependence on the maternal environment. His original concepts such as holding, the use of an object, and the object's survival of the infant's destructiveness, have been influential internationally. Originally a supporter of Melanie Klein, he became a strong critic of what he saw becoming a proselytizing movement within the British Society. Khan, an analysand of Winnicott, was a blazing comet who burnt himself out. His sparkling, erudite papers, which also bridged British and French psychoanalysis, were notable contributions though his polemical debating style demonstrated an equally noticeable self-inflation. In his later years he became isolated, somewhat paranoid and was asked to resign from the Society because many members were outraged by the anti-Semitic tone of his last book, written during his final illness.

The balance between the size and influence of the three groups varies: the "Group of Independent Analysts" is the largest in number, followed by the Klein group and then the "Contemporary Freudian" as the former "B" (Anna Freud) group was called. There is a "gentleman's agreement" that each group should be represented on committees and take turns in the significant roles of President, Scientific Secretary and Chairs of important committees. Total membership as of 2005 was 443 Members and Associate Members, many of whom live abroad. On qualification the student is elected to associate membership. Candidates for full membership are obliged to take part in a membership course with seminars and advanced supervision.

The Institute is responsible for the International Journal of Psycho-Analysis, founded by Jones in 1920;

the New Library of Psycho-Analysis, which is the successor to the original library which Jones founded in 1921 and which was published by Leonard and Virginia Woolf at the Hogarth Press; and also for the Standard Edition of Freud's work, which was undergoing a new revision as of 2004. Riccardo Steiner has demonstrated the political aim that Jones and his translators held in "standardizing" the language of psychoanalysis in the English version. In recent years there has been more activity devoted to making psychoanalysis better known to the general public through systematic courses of lectures and daylong and weekend meetings, which are more directed to interested professionals.

It is obligatory of psychotherapy training institutions to submit to regulation and registration which has brought psychoanalysts into closer collaboration but also into conflict with other psychotherapeutic training institutions. The United Kingdom Council for Psychotherapy was formed to represent and regulate psychotherapy trainings. The British Psycho-Analytical Society, together with the Society of Analytical Psychology (Jungians), the Tavistock Clinic and some other broadly psychoanalytic organizations have broken away from UKCP to form the British Confederation of Psychotherapists, so as to affirm their group identities as "psychoanalytic."

University College of the University of London has a privately funded Chair of Psychoanalysis which must be occupied by a psychoanalyst. Students can gain PhDs for research in the field of psychoanalysis and these students do not have to be members of the Psycho-Analytical Society. The Tavistock four-year training in psychoanalytic psychotherapy can lead to a PhD as well. For several years it has been possible to achieve psychoanalytic training in Scotland through a joint venture of the Scottish Institute of Human Relations and the Institute of Psycho-Analysis in London. Training is also possible in Northern Ireland and may become possible in other regions of the British Isles.

The British Psycho-Analytical Society has coped with great dissension without splitting into conflicting units and is likely to remain one body. Psychoanalysis is still regarded as a prestigious qualification and attracts good candidates, although the number of medically-qualified applicants has diminished. The Institute has always accepted women and non-medically-qualified applicants and has recently declared itself to operate a non-discriminatory admissions policy regarding sexual orientation and ethnicity.

A full account of this movement, principally associated with Ronald D. Laing and David Cooper, has been provided by Digby Tantum (1991). Laing wrote his most famous and influential book, *The Divided Self*, when he was a senior registrar at the Tavistock Clinic and in training analysis with Dr. Charles Rycroft. Although he was accepted as an associate member of the British Psycho-Analytical Society, he rapidly distanced himself from it and he and Cooper founded their own Philadelphia Association. Together they ran a community named Kingsley Hall on “anti-psychiatric” lines. The basic tenets of anti-psychiatry are as follows: Schizophrenia is not an illness, but a label arbitrarily fixed by society and confirmed by psychiatrists; the symptoms of madness are understandable as communications; what psychiatrists call schizophrenia is either a reaction to a disturbed family or a healing voyage which would be of benefit if it could be completed without interference; and, lastly, psychiatrists and psychiatric hospitals degrade people and cause mad behavior.

Laing and Arnold Esterson carried out research on families in 1958 and 1967, partly at the Tavistock Institute of Human Relations and at Villa 21, Shenley Hospital, which was directed by Cooper and which treated young schizophrenics. From their researches they concluded that schizophrenia was a reaction to familial or social pathology and that symptoms were caused by disturbed family communications. Their findings were published as “The Politics of Experience” (1967) and by Cooper as *Psychiatry and Anti-Psychiatry* (1967). As Tantum described it, “Many readers agreed with Laing that a plausible account of symptoms in terms of disturbed family communication was tantamount to proving that disturbed family communications caused symptoms. ‘The Politics of Experience’ was written at the height of the 1960’s rebellion by young people against their parents generation. It was the apogee of flower power and a year before the Paris Events. Drug induced mysticism was fashionable and was presented as a voyage of self-discovery. It was tempting to pretend that schizophrenia was not only intelligible but intelligent” (1991).

Laing’s legacy survives in the Philadelphia Association and in the Arbours Association, which is led by his former associate Joseph Berke. Both these organizations have training programs and the Arbours Association provides shelter and treatment for psychotic patients in residential homes, thus avoiding hospitalization. The

other legacy of the anti-psychiatry movement is found in the refinement of psychiatric diagnosis and in a more psychodynamic approach to both the schizoid character and to schizophrenia. The movement has also increased the momentum away from psychiatric treatment and toward self-help circles for persons who have suffered psychotic breakdowns and who try to avoid further psychiatric involvement. Laing had relatively little direct influence within the British Psycho-Analytical Society and his theories and practices were marginalized by lack of attention.

The Tavistock Clinic has a reputation for psychoanalytic psychotherapy. Founded after World War I by Hugh Crichton-Miller, it began as an eclectic center for psychotherapy where Freudians, Jungians, and Adlerians, among others, provided psychotherapeutic services. During the Second World War the director of the Tavistock Clinic, John Rawlings Rees, who was not himself a psychoanalyst, was appointed director of British Army Psychiatry. Through his influence, several future leaders of psychoanalysis, including Wilfred Bion, John Rickman, and Thomas F. Main, were given posts of high responsibility. When they returned to civilian life at the end of the war they succeeded in making the Tavistock Clinic a psychoanalytic clinic, no longer eclectic. John D. Sutherland, who succeeded Rees as director, held an early enthusiasm for group psychotherapy under the leadership of Bion (and later of Henry Ezriel). This movement eventually faded and was replaced by individual psychoanalytic psychotherapy. Over the years the Kleinian Movement became predominant and those who did not follow this school were to some extent marginalized. The most conspicuous example is that of John Bowlby, whose research into the links between ethology and psychodynamic theory was regarded as extraneous. Bowlby had created the Department of Family and Children and introduced a systems approach to the pathology of the family and because of his “contamination” by such ideas he was also marginalized in the British Psycho-Analytical Society, of which he had been a prominent member since the 1930s. Before his death, however, the importance of his contribution was recognized internationally and thereby he regained recognition within Britain.

Michael Balint did a great deal to make the name of the Tavistock Clinic known internationally through his work with family doctors. Together with his wife Enid, he carried out extensive research into

psychodynamic aspects of general practice, and “Balint Groups” spread worldwide. Balint had succeeded Ferenczi as the Director of the Hungarian Psychoanalytic Institute but came to Britain in the 1930s as a refugee. He quickly established a strong position for himself as a representative of the Hungarian school of psychoanalysis and was recognized as one of the leaders of the “Independent” group, in time becoming President of the Society. He also stimulated research into brief psychotherapy, which was carried out by a group of psychoanalysts drawn from the Tavistock Clinic and the Cassel Hospital.

The Cassel Hospital, too, was founded following World War I, to provide inpatient psychotherapy, and between the wars it became more psychodynamic in its approach. Following World War II, Thomas Main became its director, and the hospital became a center for psychoanalytic inpatient psychotherapy. Many psychoanalysts in training were employed there. The hospital gained a worldwide reputation for its innovations in psychodynamic nursing and for its contributions to the therapeutic community movement. The Cassel can be contrasted to the Henderson Hospital which under Maxwell Jones took an approach to inpatient psychotherapy that was socio-psychological rather than psychoanalytic.

MALCOLM PINES

### **Bibliography**

- Cooper, David. (1967). *Psychiatry and anti-psychiatry*. London: Tavistock
- Hinshelwood, Robert D. (1991). Psychodynamic psychiatry before World War I. In Berrios and Freeman, (Eds.), *150 years of British psychiatry*. London: Gaskell.
- Miller, P.; Rose, N.; and Pines, Malcolm. (1994). On therapeutic authority: psychoanalytic expertise under advanced liberalism. *History of the Human Science*, 7 (3), 9–64.
- Pines, Malcolm. (1991a). The development of the psychodynamic movement. In Berrios and Freeman, (Eds.), *150 years of British psychiatry*. London: Gaskell.
- . (1991b). A history of psychodynamic psychiatry in Britain. In J. Holmes (Ed.): *Textbook of psychotherapy in psychiatric practice*. Livingstone, England: Churchill.
- Tantum, Digby. (1991). The anti-psychiatry movement. In Berrios and Freeman, (Eds.), *150 years of British psychiatry*. London: Gaskell.

## **GREECE**

Reference to the history of psychoanalysis in Greece lends itself to reflection along two different lines.

First, there is the history of events—that is, the diachronic line of events that, between 1915 and the 1980s and 1990s, sustained the slow (and somewhat difficult, owing to discontinuities) establishment of a framework for the psychoanalytic movement in Greece, with all of the consequences, both positive and negative, that such a framework entailed for psychoanalytic circles. This chronology shows that, around 1920, a circle of intellectuals and teachers were actively studying the works of Sigmund Freud and publishing on practices in psychotherapy and psychoanalysis. However, the official medical community and the broader public remained indifferent or even hostile to these currents of thought.

The active presence of Princess Marie Bonaparte in Athens beginning in 1946 seemed to offer a way of changing things. The interest of academics and doctors was mobilized on the occasion of a visit by Anna Freud, who was invited to Athens in 1949, but this lasted only for the short duration of her stay. Only two psychiatrists, Démétrios Kouretas and Georges Zavitzianos; a poet, Andreas Embirikos; and a physician, Nicolas Dracoulides, were interested in pursuing more in-depth psychoanalytic training. These four men formed a working group, and, supported by Marie Bonaparte, were accepted as members of the Société psychanalytique de Paris (Psychoanalytic Society of Paris) in 1950. However, the group was to be short-lived: It disbanded a year later, the four analysts having chosen to settle in three different countries.

After the end of World War II and the civil war that ravaged Greece, the creation of a few institutional, psychodynamically oriented mental health centers made it feasible to organize lecture series, seminars, and group discussions in Athens; these developments seemed to portend a possible new beginning for analytic work. Colleagues from abroad—Serge Lebovici was the first—were prepared to offer assistance, beginning in 1957. Three Greek analysts working in different areas—Kouretas at the University of Athens, Pangiotis Sakellaropoulos at the Center of Thétokos, and Anna Potamianou at the Center for Mental Health and Research—provided the impetus, as hopes for a new beginning took shape. And once again, the central

figures comprised two psychiatrists and one person from outside of that field.

Numerous attempts to ensure sustained and systematic collaboration did not yield results. It was not until 1982, after countless efforts and failures, and with the help of a group of analysts who had trained overseas (Athena Alexandris, Pierre Hartocollis, Stavroula Beratis), that a “Greek psychoanalytic group” gained formal recognition as a study group of the International Psychoanalytic Association (IPA). This group, which includes four teaching analysts, ten members, eight corresponding members, and twenty-six candidates, was designated by election as an IPA member society in 2001.

Between 1989 and 1995, two groups inspired by the work of Jacques Lacan, the Freudian Praxis, and the Athenian Circle of the European School of Psychoanalysis, as well as another group whose members wished to remain independent of any school, were formed. Still two other groups follow the teachings of Alfred Adler. Thus, the diachronic axis in Greece reveals considerable oscillation between forward movement and movements of regression-repetition, attesting to an unconscious, but definite, fidelity to Freudian thought in connection with the psychic trajectory of individuals and groups.

A second line of reflection brings out even more clearly the similarities between the course of development of psychoanalysis in Greece and the very essence of the Freudian *Logos*. Marked by a convergence between the Jewish soul and the Hellenistic spirit, Freud’s thought engraved a path of complementary opposites and constraints that mirrors the history of psychoanalysis in Greece. That history, it seems, is the fruit of conflicts whose unexpected violence often astonished spectators; it is also the result of harsh schisms and mutilating projections, the revelatory details of which can be found in the writings of those involved in its difficult and laborious gestation.

Opposition and indifference arose within the group; analysts departed to seek training abroad. There were abortive attempts, productive convergences, jolts, and contacts. It is certain that the development of psychoanalysis was not exempt from tumultuous adventures in any country. However, it is equally certain that in this land that engendered what for Freud doubled as the alien element of the unconscious—that is, the discourse and

myths of the ancient Greeks—the constraint of rejection and exclusion of analytic thought exerted its influence for too long. There are a variety of reasons for this, and they have been studied and discussed by such authors as Gerosimos Stephanotos, Athanase and Hélène Tzavaras and Anna Potamianou. Currently, this constraint has been eased somewhat. For Freud, the journey leading to Athens was not easy; the price he paid in terms of his autoanalysis was considerable. For Greek analysts today, there is certainly a price to be paid so that analysis may “be” in their country.

With regard to publications in Greek: Kouretas and Zavitzianos published numerous works, mainly concerning clinical practice and applied psychoanalysis. More recently, Greek psychoanalysts have mostly tended to publish in the language in which they received their training (English, French, or German), but numerous articles and several books, including four collaboratively written volumes, have also been written in Greek.

ANNA POTAMIANOU

### ***Bibliography***

- Potamianou, Anna. (1988). Episkepsis: Pensées autour de la visite d’Anna Freud à Athènes. *Revue internationale d’histoire de la psychanalyse*, 1, 247–254.
- Stephanatos, Gerosimos. (1992). Un pari sous l’Acropole. *Bulletin d’information du Quatrième Groupe*, 12, 56–63.
- Tzavaras, Athanase. (1993). Psychanalyse “et” Grèce—dix ans après. *IO—Revue Internationale de Psychanalyse*, 4, 157–162.
- Tzavaras, Hélène. (1993). Oedipe ou Ulysse? Identité et filiation de la psychanalyse en Grèce. *IO—Revue Internationale de Psychanalyse*, 4, 87–93.
- Tzavaras, Hélène, and Tzavaras, Athanase. (1995). Au pays d’Oedipe. *Panoramiques*, 22, 156–158.

---

### **GREENACRE, PHYLLIS (1894–1989)**

Phyllis Greenacre, American psychoanalyst and physician, was born May 3, 1894 in Chicago, Illinois, and died October 24, 1989 in Ossining, New York.

Greenacre was the fourth of seven children of Isaiah Thomas, a prominent lawyer, and Emma Russell. After graduating from Rush Medical College in Chicago, in



1916, she became an intern and resident at the Phipps Clinic at the Johns Hopkins Hospital in Baltimore (Harley and Weil, 1990).

At the Phipps Clinic, where Greenacre remained for twelve years, she came into contact with the great Swiss-American psychiatrist, Adolf Meyer. Her exposure to Meyer reinforced her conviction of the inextricable link between biology and psychology. In 1932 she began psychoanalytic training at the New York Psychoanalytic Institute, graduating in 1937. In 1942 she was appointed a training analyst and henceforth served in a number of important institutional positions at the Institute.

During this period there was a growing influx of émigré analysts to the United States and particularly to New York. Greenacre was influenced by two of these émigrés, Heinz Hartmann and Ernst Kris. Her friendship with Kris was particularly significant because he encouraged her to value her unique analytic vision.

Greenacre's written contribution falls into three categories: clinical papers on development; psychoanalytic training and therapy; and studies of creativity. Her first paper, "The Predisposition to Anxiety" (1941), was criticized for its exploration of preverbal stages of development, and her argument that the roots of anxiety might predate the existence of the ego. This paper and its companion, "The Biological Economy of Birth" (1945), are also noteworthy because they announce her interest in memory and its vicissitudes. Greenacre's clinical work took as its point of departure her conviction of the importance of reconstruction in analytic work. She paid close attention to screen memories, believing them the path by which early preverbal experiences could be traced.

In the early 1950s Greenacre began writing on fetishism, and observed that fetishists had an especially mutable body image. The fact that descriptions of bodily changes were central to the writings of Lewis Carroll and Jonathan Swift led to the biographical study *Swift and Carroll* (1955). She wrote a number of papers on creativity, and proposed a theory of aggression, in *The Childhood of the Artist* (1957), as a manifestation of a positive developmental force; aggression as a positive response by the infant to the circumstances of its earliest experiences, both frustrating and gratifying.

Greenacre's contributions to psychoanalysis include original insights about the bodily and psychic

experiences of the preverbal child, fetishism, and the creative individual. Of equal note is the fact that she presented this material in papers and books that are characterized by beautiful, evocative prose, in the service of imaginative and bold theoretical ideas and the sensitive interpretation of clinical material.

NELLIE L. THOMPSON

See also: Allergy; As if personality, Identity; Imposter; *Trauma of Birth, The*.

### Bibliography

- Greenacre, Phyllis. (1941). The Predisposition to Anxiety. In *Trauma, growth and personality* (pp. 27–82). New York: W. W. Norton, 1952.
- . (1945). The Biological Economy of Birth. In *Trauma, growth and personality* (pp. 3–26). W. W. Norton, 1952.
- . (1955). *Swift and Carroll, a psychoanalytic study of two lives*. New York: International Universities Press.
- . (1957). The Childhood of the Artist: Libidinal Phase Development and Giftedness. In *Emotional growth, psychoanalytic studies of the gifted and a great variety of other individuals* (2 vols., p. 479–504). New York: International Universities Press.
- Harley, Marjorie, and Weil, Annemarie. (1990). Phyllis Greenacre, M.D. (1894–1989). *International Journal of Psychoanalysis*, 71, 523–525.

---

## GREENSON, RALPH (1911–1979)

Ralph Greenson, American psychoanalyst and physician, was born on September 20, 1911 in Brooklyn, New York, and died on November 24, 1979 in Los Angeles, California.

He was the eldest child (by ten minutes, as he was a twin) born to his physician father and pharmacist mother in Brooklyn. He completed his premedical studies at Columbia University and his medical training at the University of Bern (1930–1934) in Switzerland. In Switzerland he met Hildi Troesch; they married and had two children, Daniel and Joan.

In 1935 he began an analysis with Wilhelm Stekel and undertook analytic training in the Active Psychoanalytic Institute in Vienna. Dissatisfied with the therapeutic effect of this work, he began "classical"

training in Los Angeles in 1938 and had a personal analysis with Otto Fenichel. He held various positions in organized psychoanalysis, but mostly enjoyed teaching candidates, residents and medical students. He gave many public lectures which were very popular and well received. These were published in book form, as *Loving, Hating, and Living Well* (1993).

He published 65 articles in the psychoanalytic literature, almost all of which were clinically based. Thirty-two of these appear in his book *Explorations in Psychoanalysis* (1978). *The Technique and Practice of Psychoanalysis* (1967) is still considered a classic book on analytic technique. In addition to his books on technique, his major contribution to psychoanalysis involved his emphasis on aspects of analytic work: the working alliance—the “real” relationship with patient’s empathy and counter-transference, apart from transference interpretations.

DANIEL GREENSON

*See also:* Abstinence/rule of abstinence; Boredom; Empathy; Identity; Silence; Technique with adults, psychoanalytic; Therapeutic alliance; Transference relationship.

### **Bibliography**

- Greenson, Ralph. (1965). The working alliance and the transference neurosis. *Psychoanalytic Quarterly*, 34 p. 155–181.
- . (1967). *The technique and practice of psychoanalysis* (Vol. 1). New York: International Universities Press.
- . (1970). The exceptional position of the dream in psychoanalytic practice. *Psychoanalytic Quarterly*, 39, 519–549.
- . (1978). The “real” relationship between the patient and the psychoanalyst. In *Explorations in Psychoanalysis* (p. 425–440). New York: International Universities Press. (Original work published 1971)
- . (1978). *Explorations in psychoanalysis*. New York, International Universities Press.

## **GROSSOT, MICHEL (1918–1975)**

Michel Gressot, a Swiss physician, psychoanalyst and teacher with the Société Suisse de Psychanalyse (Swiss Society for Psychoanalysis) was born in Porrentruy in 1918 and died in Geneva in 1975. He attended the Collège de Saint-Maurice (Valais), where he acquired

an extensive background in humanism and philosophy that was to have a profound affect on his psychoanalytic work. After studying medicine in Fribourg, Basle, and Lausanne, he specialized in psychiatry in Lausanne, in Malévoz (Valais), and in Geneva, where he settled in 1950 as a psychiatrist and psychoanalyst. In 1969 he was appointed *Privat Dozent* at the School of Medicine of the University of Geneva.

Gressot was introduced to Freud’s work through his teachers at Saint-Maurice. Subsequently, during his psychiatric training, he began a personal analysis with Charles Odier in Lausanne. Once settled in Geneva he devoted himself almost exclusively to psychoanalysis. Raymond de Saussure, upon his return from the United States in 1952, relied on Gressot’s assistance in providing a new impetus to the development of psychoanalysis and training (after 1956 he worked with Marcelle Spira). These psychoanalytic educators played an important role in the later growth of psychoanalysis in French-speaking Switzerland, especially in Geneva. Gressot regularly gave seminars and conferences, and was an enthusiastic participant in the Congrès des psychanalystes de langue romane (Congress of romance language psychoanalysts). His career was interrupted suddenly in 1975, when he died in Geneva at the age of fifty-seven.

Gressot’s most important contributions were collected by Michel de M’Uzan in a posthumous volume entitled *Le Royaume intermédiaire* (1979), with a preface by Michel Roch. It contains his essay, “Le Mythe dogmatique et le Système moral des manichéens,” which emphasizes the psychoanalytic advantage in studying Manichaeism. The book also contains two important reports on congresses held in Paris. The first, from 1955, “Psychanalyse et Connaissance: Contribution à une épistémologie psychanalytique,” sketches a psychoanalytic theory of knowledge. The second, from 1963, “Psychanalyse et Psychothérapie, leur commensalisme: L’esprit de la psychanalyse est-il compatible avec la psychothérapie?” studies the interaction of the fields of psychoanalysis and psychotherapy from a dialectic point of view that was typical of Gressot’s style.

Gressot trained a number of psychoanalysts during his career. The depth of his thought, his attention to detail as a writer, and his openness to different ideas all had a strong influence on the growth of psychoanalysis inside and outside Switzerland.

JEAN-MICHEL QUINODOZ

See also: Congrès des psychanalystes de langue française des pays romans; Switzerland (French-speaking)

### Bibliography

Gressot, Michel. (1979). *Le royaume intermédiaire*. Paris: Presses Universitaires de France.

Roch, Marcel. (1979). Préface: En hommage à Michel Gressot. In Michel Gressot, *Le royaume intermédiaire*. Paris: Presses Universitaires de France.

——— (1980). À propos de l'histoire de la psychanalyse en Suisse romande. *Bulletin de la Société suisse de psychanalyse*, 10, 17–30.

## GRID

The grid is an instrument for classifying psychoanalytic material, coming from either the patient or the analyst, proposed by Wilfred R. Bion in his *Elements of Psycho-Analysis* (1963). Classification is made along two axes, with the vertical axis representing the genetic evolution of thoughts or ideas, and the horizontal axis representing the uses or functions attributed to thoughts or ideas. By combining the vertical categories with the horizontal uses or functions, a grid is obtained that makes it possible to classify the “elements of psycho-analysis”—the term Bion applies to the thoughts and emotions of the patient-analyst dyad.

Bion does not advocate using the grid as a working method during sessions. Rather, it is conceived as a tool that the analyst can use outside of the sessions to clarify their ideas or reexamine material.

By means of the grid and other abstract systems of notation, Bion sought to bring a greater degree of specificity to psychoanalytic theory. For example, in the theory of the Oedipus complex that helped Sigmund Freud to found psychoanalysis, there are elements that are constants, fixed through their association with other elements. Thus, in the classic oedipal scheme, it would be impossible to detach any of the following from the whole: sexual agitation, sexual curiosity, or castration. Bion's use of new methods of notation began with his book entitled *Learning from Experience* (1962) and reached its height with *Transformations: Change from Learning to Growth* (1965), where the reader finds a profusion of mathematical signs, Greek words, arrows, dots, and lines, the assimilation of which (when it is possible) adds little to analytic understanding. Bion himself admitted his failure, referring to his mathematics as

“Dodgsonian,” in reference to Charles Dodgson (Lewis Carroll), the author of *Alice's Adventures in Wonderland*. The grid was not as ill-fated as Bion's other notation systems and has even become emblematic of his research.

Arranged along the vertical axis of the grid are the following: A) beta-elements; B) alpha-elements; C) dream thoughts, dreams, and myths; D) preconception; E) conception; F) concept; G) a scientific deductive system; H) algebraic calculus.

The horizontal axis essentially presents the functions the mind uses to have access to the real: 1) definitory hypotheses; 2) denial; 3) notation; 4) attention; 5) inquiry; 6) action.

If, in the horizontal axis, Bion draws from Freud's 1911 article, “Formulations on the Two Principles of Mental Functioning,” the vertical axis instead reflects the influence of Immanuel Kant's epistemology.

As a whole, the grid recalls Kant's categories (much more than it does Dimitri Mendeleev, contrary to what some have suggested). Like in Kant's faculty of thought, there are three levels in the grid: sensibility, understanding, and reason. Sensibility, in Kant's work, is predominantly passive and serves to receive impressions from the outside (the equivalent of Bion's lines A, B, and C). Understanding is active; it takes sensibility's components and forms them into judgments and real knowledge (the equivalent of Bion's lines D, E, and F). Reason is the final stage in the operations of knowledge, which are begun by the senses and continue through the understanding.

For all its interest, Bion's grid did not achieve the degree of abstraction he believed was desirable in the development of any scientific theory. The grid did not produce the desired combinatory effects, in the same way that psychoanalytic theory is not at the level of a predictive scientific system. Perhaps the ascent into abstraction is not possible for psychoanalysis, just as it is not possible for the other human sciences. Walking in the footsteps of Ludwig Wittgenstein, Ernst Mach, and Bertrand Russell, Bion did not take into account the methodological obstacles raised when one attempts to assimilate the natural and human sciences—obstacles evoked by Wilhelm Dilthey in his *Introduction to the Human Sciences: An Attempt to Lay a Foundation for the Study of Society and History* and by Georges Politzer in his *Critique of the Foundations of Psychology: The Psychology of Psychoanalysis*, among others.

PEDRO LUZES

**BION'S GRID**

	Definitory hypothesis <b>1</b>	↓ <b>2</b>	Notation <b>3</b>	Attention <b>4</b>	Inquiry <b>5</b>	Action <b>6</b>	...n.
<b>A</b> Beta-elements	A1	A2				A6	
<b>B</b> Alpha-elements	B1	B2	B3	B4	B5	B6	...Bn.
<b>C</b> Dream thoughts, dreams, and myths	C1	C2	C3	C4	C5	C6	...Cn.
<b>D</b> Preconception	D1	D2	D3	D4	D5	D6	...Dn.
<b>E</b> Conception	E1	E2	E3	E4	E5	E6	...En.
<b>F</b> Concept	F1	F2	F3	F4	F5	F6	...Fn.
<b>G</b> Scientific deductive system		A1					
<b>H</b> Algebraic calculus							

SOURCE: In W.R. Bion, *Elements of Psychoanalysis*, London: Heinemann.

See also: Concept; Container-contained; *Learning from Experience*; Maternal reverie, capacity for; Preconception.

Trans.). Pittsburgh: Duquesne University Press. (Original work published 1928)

**Bibliography**

Bion, Wilfred Ruprecht. (1963). *Elements of psycho-analysis*. London: Heinemann.

———. (1965). *Transformations: Change from learning to growth*. London: Heinemann.

Politzer, Georges. (1994). *Critique of the foundations of psychology: the psychology of psychoanalysis* (Maurice Apprey,

**GRODDECK, GEORG WALTHER (1866–1934)**

A German physician and the director of a clinic in Baden-Baden, in the Black Forest region, Georg Walther Groddeck was born on October 13, 1866, in Bad Kösen

an der Saale, Germany, and died on June 11, 1934, in Knonau bei Zürich, Switzerland. Groddeck detailed his upbringing in his autobiographical writings. A saying of his mother's, "Big ears mean great accomplishments," became his life motto. The youngest of five children in a family of aristocrats, he was educated at the school in Schulpforta where Gotthold Lessing, Otto Rank, and Friedrich Nietzsche also studied. He was a great admirer of Nietzsche and Johann Wolfgang von Goethe, among others. He studied medicine with Ernst Schwenger, Otto von Bismarck's personal physician, in keeping with a Romantic tradition of medicine based on experience, in contrast to the scientific mindset of his era. As a result of his exceptionally powerful personality, Groddeck became a renowned doctor whom patients throughout Europe came to consult about somatic and psychosomatic illnesses. He initially used hydrotherapy, dietetics, massage therapy, and psychotherapy based on authority and the power of suggestion; he later refined this approach into a form of psychoanalytic-psychosomatic therapy.

In 1910, during a life crisis, he discovered the writings of Sigmund Freud, and he completed his self-analysis in the course of the 115 lectures on psychoanalysis that he delivered to patients in his clinic between 1916 and 1919. These lectures later became famous.

He began corresponding with Freud in 1917 and met him personally in 1920, at the international psychoanalytic congress in the Hague. Groddeck drew a mixed reception with his presentation at the congress, which he supposedly introduced by saying, "I am a wild psychoanalyst," and in which, associating freely, he spoke of his childhood enuresis. In 1920 he became a member of the Deutsche psychoanalytische Gesellschaft (German Psychoanalytic Society). But he did not fully integrate himself into the psychoanalytic movement, and he followed his own path whenever personal ties were important and institutional constraints bothersome. He took a skeptical view of the new ego psychology.

Throughout his life he remained involved in sociopolitical activist groups. He refused to accept the National Socialists' reining in of German psychoanalysts after 1933 and ran up against insurmountable problems with them. Finally, he had to take refuge in Switzerland.

In 1917 he put forward his psychoanalytic-psychosomatic agenda in *Psychische Bedingtheit und psychoanalytische Behandlung organischer Leiden* (Psychic

determination and psychoanalytic treatment of organic disorders). Using examples from his clinical work and vignettes from his self-analysis, he described the relationship between somatic disorders and unconscious psychic processes. In 1921 he published *Der Seelensucher: ein psychoanalytischer roman* (The soul-seeker: a psychoanalytic novel), a humorous account of the adventures of a psychoanalytic Don Quixote. Groddeck considered this his best work, as did Freud; others complained that it was sexually indecent and unscientific. With the publication of the *The Book of the It* (1923/1928), Groddeck became famous. This was yet another extremely personal book: clinically oriented, spontaneous, unconventional. This work was followed by many lectures, articles in the journals *Satanarium* and *Die Arche*, and, in 1933, *Der Mensch als Symbol: unmassgebliche Meinungen über Sprache und Kunst* (Man as symbol: considerations, without pretension, on language and skills). Groddeck's correspondences with Freud and with Sándor Ferenczi are well known. Most of his works are available in translation in many languages.

Groddeck was important above all in psychoanalytic psychosomatics. He was the first to argue for the value of psychoanalysis in theorizing about the mind and for the treatment of not just conversion but all somatic disorders, which he supported with a large amount of clinical data. His work is still controversial because his method was neither rational nor scientifically rigorous. Instead, he followed the primary processes in both his therapeutic work and his writings. Using this way of thinking, which Hanns Sachs described as a "self-portrait of the unconscious," he presented psychoanalysis as an activity, not a theory. Drawing on Nietzsche and the critical philosophy of consciousness, he stressed the concept of the id, a concept that Freud took up, but in a modified form. (He advocated saying, "The id thinks in me," and not "I think.") He recognized the significance of regression, pre-oedipal desires, and maternal transference, and thus had an enormous influence on Ferenczi, with whom he became friends. He was also in contact with Ernst Simmel, Frieda Fromm-Reichmann, and Michael Balint. The educated public and several writers (Lawrence Durrell and Ingeborg Bachmann, among others) took a great lay interest in his work, and the French psychoanalysts Roger Lewinter, Pierre Fédida, Jean-Bertrand Pontalis, Octave Mannoni, and François Roustang were receptive to his ideas for their scientific content.

HERBERT WILL

See also: Allgemeine Ärztliche Gesellschaft für Psychotherapie; *Book of the It, The*; Germany; Id; Psychic causality; Psychosomatic.

### Bibliography

- Bos, Jaap. (1992). On the origin of the id (*das Es*). *International Review of Psychoanalysis*, 19, 433–443.
- Chemouni, Jacquy. (1984). *Georg Groddeck, psychanalyste de l'imaginaire: psychanalyse freudienne et psychanalyse groddeckienne*. Paris: Payot.
- Groddeck, Georg. (1917). *Psychische Bedingtheit und psychoanalytische Behandlung organischer Leiden*. Leipzig: S. Hirzel.
- . (1928). *The book of the it*. Washington, DC: Nervous and Mental Disease Publishing Co. (Original work published 1923.)
- . (1933). *Der Mensch als Symbol: unmassgebliche Meinungen über Sprache und Kunst*. Leipzig: Internationaler psychoanalytischer Verlag.
- . (1951). *The world of man* (V. M. E. Collins, Trans.). New York: Funk & Wagnalls Co.
- . (1977). *The meaning of illness: selected psychoanalytic writings* (Gertrud Mander, Trans.). London: Hogarth Press.
- Grossman, Carl M., and Grossman, Sylva. (1965). *The wild analyst: the life and work of Georg Groddeck*. New York: Braziller.
- Grotjahn, Martin. (1966). Georg Groddeck: the untamed analyst. In Franz Alexander, Samuel Eisenstein, and Martin Grotjahn (Eds.), *Psychoanalytic pioneers*. New York: Basic Books, 1966.
- Will, Herbert. (1987). *Georg Groddeck: die Geburt der Psychosomatik*. Munich: Deutscher Taschenbuch Verlag (dtv).
- . (1994). Ferenczi und Groddeck: eine Freundschaft. *Psyche*, 720–737.

## GROSS, OTTO HANS ADOLF (1877–1920)

Otto Gross, a neurologist and psychoanalyst, was born March 17, 1877, in Feldbach (Styria), Austria, and died February 13, 1920, in Berlin. His father, Hans Gross, was a celebrated professor of criminal law and his mother Adèle came from a middle-class family. Young Otto Gross grew up in a well-to-do family environment and was a precocious child.

On the advice of his father, he began studying medicine and completed his degree at the University of Graz in 1899 at the age of twenty-two. He was hired as a

doctor on a cruise ship, which introduced him to South America—and drugs. He was also involved with several women during this time, something that earned him a rebuke from his father on his return, the beginning of a conflict that would last until 1907 and their final break. In 1903 he married Frieda Schloffer, “one of the only Germans I have ever liked,” wrote Freud. But his sexual life remained agitated, the reflection of the “sexual immorality” he would turn into a theoretical credo.

In 1901–1902 he specialized in neurology and was especially interested in the hypotheses of Carl Wernicke on associative circuits and their separation (in a February 1908 letter to Carl Gustav Jung, Freud humorously referred to this as “sejunction”). In 1902, he began a detoxification cure at the Burghölzli Clinic, where Jung was working, and discovered psychoanalysis.

In spite of his appointment as *Privat Dozent* at the University of Graz, he left the city—where his father had also received an appointment—to settle, in September 1906, in Munich. Here, as an assistant to Emil Kraepelin, he spent time among the artistic and literary circles in the Schwabing quarter. The following year he went to Amsterdam for the first International Congress on Psychiatry, Psychology, and Aid to the Mentally Ill and, with Jung, defended Freud’s theory of hysteria. His intellect and creativeness caught Freud’s (who felt that “unfortunately he was not quite sane”) and Ernest Jones’s attention, and he was present at the Salzburg Congress of April 27, 1908.

Gross was again hospitalized at the Burghölzli, where Jung began treating him. Jung kept Freud informed of his progress, for both men felt that because of Gross’s intelligence this was a unique opportunity to develop further theoretical insights. Jung diagnosed an “obsessive neurosis” in 1908, which was confirmed by Freud. Gross’s condition seemed to get better. He gave up drugs—opium and cocaine—but things soon got worse, and in June 1908 Jung diagnosed him as suffering from “precocious dementia” after Gross escaped from the clinic and displayed increasing symptoms of pathological behavior. Nonetheless, he continued to work and publish articles in which he explained his theories on the social origin of nervous disturbances. He became involved with anarchist circles, but spent increasing amounts of time in psychiatric clinics, which were paid for by his father.

In 1909, his book *Über psychopathische Minderwertigkeiten* (On Psychopathic Inferiority) was published.

On June 3, Freud referred to Gross's book, in which he establishes a connection between genius and degeneracy, as a "bold synthesis overflowing with ideas." The "degenerate," although appearing unsuited to current social life, can also represent the future of the culture. In 1913 Gross published, in the Expressionist review *Aktion*, an essay entitled "Zur Überwindung der kulturellen Krise" (How to Overcome the Cultural Crisis), in which he affirmed that "the psychology of the unconscious is the philosophy of revolution." He referred to Friedrich Nietzsche and Sigmund Freud, and one can only wonder what influence this early work may have had on the Marxist psychoanalysts of the following decades.

A few months after its publication, at his father's request, Otto Gross was expelled from Germany, held in Austria at the Tulln Asylum, and placed under his father's care. The international press began to print articles about his arbitrary internment and, on January 25, 1914, he was transferred to the Troppau Asylum in Silesia, where he remained until July 8. He then followed a treatment with Wilhelm Stekel, who refused to diagnose him as a schizophrenic and spoke only of a serious neurosis accompanied by drug addiction. In the *Zentralblatt für Psychoanalyse und Psychotherapie*, Gross published an article on the symbolics of destruction.

His father's death in 1915 left Gross distraught. At the start of the First World War, he worked as a volunteer in several military hospitals but was himself hospitalized again in Romania for drug addiction at the end of 1916, before being transferred to Munich to stay with his mother, then to Vienna. His writings appeared in various political reviews and made use of psychoanalysis to criticize education, society, and the patriarchy, which communism would supposedly abolish in favor of a matriarchy ("The Fundamentally Communist Conception of the Symbolics of Paradise," July 1919). He is mentioned in a letter from Sándor Ferenczi to Freud on February 7, 1918: He "made his circle of disciples there, who, among other things, had the duty without exception to enter into sexual relations with Dr. Gross's lover, named 'Mieze.' They supposedly classified the young colleague, who found that repugnant, as 'morally unreliable' for that reason. Incidentally, the young colleague had some time ago received news of Dr. Gross's death, which has, however, not been substantiated. He will still pop up here and there as a 'Golem'."

In 1920 he published his last book, *Drei Aufsätze über den inneren Konflikt* (Three papers on the inner

conflict), this conflict being situated between the "self" and the "foreign," which established a conflict between Freudian sexual drives and the Adlerian ego drive.

He was found unconscious on a Berlin sidewalk on February 11, 1920, and died in the Pankow sanatorium two days later from pneumonia. He was buried "by mistake" in the Jewish cemetery of Berlin.

Known to Franz Kafka, Max Brod, Max Weber, Blaise Cendrars (who protested against his internments), and the Dadaists, this "Golem" continued to be referred to in connection with D. H. Lawrence (whose wife Frieda, born Frieda von Richthofen, had been his mistress in 1912) and the Bloomsbury group. Guillaume Apollinaire had written "La disparition du Dr Gross" in the *Mercure de France* on January 16, 1914, to protest his internment, and Sándor Ferenczi wrote to Freud, on March 22, 1910, "There is no doubt that, among those who have followed you up to now, he is the most significant. Too bad he had to go to pot." Ernest Jones wrote in his memoirs that "[h]e was the nearest approach to a romantic ideal of a genius I have ever met. . . . He was my first instructor in the technique of psychoanalysis" (Jones, 1959, p. 173). Paradoxically, the Marxist Freudians seem to have forgotten Gross, their earliest precursor.

ALAIN DE MIJOLLA

See also: Germany; Politics and psychoanalysis.

### Bibliography

- Dehmlow, Raimund, and Heuer, Gottfried. (1999). *Otto Gross: Werkverzeichnis und Sekundärschrifttum*. Hannover: Laurentius.
- Freud, Sigmund and Jung, Carl Gustav. (1975). *The Freud/Jung Letters: The correspondence between Sigmund Freud and C. G. Jung* (William McGuire, Ed.; Ralph Manheim and R.E.C. Hull, Trans.). Princeton, NJ: Princeton University Press.
- Gross, Otto. (2000). *Collected works*. (Lois Madison, Ed. and Trans.). Hamilton, NY: Mindpiece.
- Hurwitz, Emmanuel. (1979). *Otto Gross: Paradies-Sucher zwischen Freud und Jung*. Zürich.
- Lawrence, David Herbert, and Richthofen, Frieda von. (1961). *The memoirs and correspondence*. London: E.W. Tedlock Jr.

## GROUP ANALYSIS

Broadly defined, group analysis is a psychoanalytic approach to the experience of the unconscious in the group situation and a method for investigating the psychic structures and processes that manifest themselves in that context. It uses concepts and techniques from individual psychoanalysis, as well as original psychoanalytic observations from the study of groups. In a more restricted sense, group analysis is a technique of group psychotherapy.

Trigant Burrow proposed the notion of “group analysis” in 1927, but it was only at the beginning of the 1940s that Siegmund Foulkes, John Rickman, and Henry Ezriel founded the “Group Analysis” tendency in London. Their work was informed by the structural perspective of Gestalt theory. At around the same time, Wilfred R. Bion was developing original ideas about group structures and processes based on basic concepts of psychoanalysis and Sigmund Freud’s speculations on group psychology. Foulkes’s initial objective was to propose an alternative to the limitations of individual therapy, while Bion’s aim was to explore the ways in which group processes could be specifically mobilized in the treatment of certain traumatic, borderline, and psychotic pathologies.

In the theoretical current inspired by Foulkes, the group is a totality; the individual and the group form a figure-ground whole. Within the group, the individual is like the nodal point in a neural network. Foulkes believed that all illness is produced within a complex network of interpersonal relations. In *Therapeutic Group Analysis* (1964), he writes: “Group psychotherapy is an attempt to treat the entire network of problems, either at the point of origin in the primitive group of origin, or by placing the disturbed individual into the conditions of transference within an alien group.” The group possesses specific therapeutic properties, which are expressed in the five basic tenets of Foulkesian group analysis: the capacity to listen to, understand, and interpret the group as a totality in the “here and now”; taking into account only the transference “of the group” on the analyst and not lateral transferences; the notion of “unconscious fantasmatic resonance” among the members of the group; “shared tension” and the common denominator of the unconscious fantasies of the group; and the notion of the group as a “psychic matrix” and frame of reference for all interactions.

In his 1961 book *Experiences in Groups*, Bion distinguishes and articulates two modes of psychic functioning in groups: the “work (or *W*) group,” dominated by the processes and requirements of secondary logic; and the “basic-assumption group” defined by the concept of group mentality (p. 105ff). “Group culture” is the structure acquired by the group at a given time, its self-assigned tasks, and the organization adopted to perform them. Bion defines “group mentality” as the mental activity that takes shape within a group based on the opinions, will, and the unconscious, unanimous, and anonymous desires of its members. It ensures that group life will correspond to the basic assumptions that determine its course. Basic assumptions are made up of intense emotional states, primitive in their origin, that play a determining role in a group’s formation, the performance of its task, and the satisfaction of the needs and desires of its members. An expression of unconscious fantasies, these assumptions submit to the primary process and remain unconscious. Basic assumptions are also defensive group reactions used as magical techniques, especially for combating the psychotic anxieties reactivated by the regression the group situation imposes. Three basic assumptions govern the course of psychic phenomena specific to the group and satisfy the desires of its members. The basic assumption of dependency (*baD*) is grounded in the conviction that the group has come together to receive security and the satisfaction of all the needs and desires of its members from someone (therapist, leader, master) or something (idea, ideal) upon whom (or which) it is absolutely dependent. The corresponding group culture is organized around the search for a more-or-less deified leader and manifests itself in passivity and loss of critical judgment. The basic assumption of fight-flight (*baF*) rests on the collective fantasy that there exists an internal or external bad object embodied in an enemy: a group member, illness, an adverse or erroneous idea that the group must either attack or flee. The group finds its leader among paranoid personalities likely to feed this idea. The basic assumption of pairing (*baP*) is sustained by the collective fantasy that some being or event will resolve all the group’s problems: Messianic hope is placed in a couple whose child will save the group from hatred, destruction, or despair. Group culture is organized around the idea that the future will bring long-awaited solutions, but for the future to come, their messianic hope must never be realized. In his book *Group*, the Italian writer Claudio Neri



extended and further elaborated Bion's ideas into field theory.

The French current of thought in group analysis has focused its research on the unconscious function the group fulfills for its members. Jean-Bertrand Pontalis (1963) emphasized the importance of instinctual cathexis and representations whose object is the group. According to Didier Anzieu in *Le Groupe et l'Inconscient*, the group, like the dream, is essentially a means and a locus for the imaginary fulfillment of the unconscious desires of its members. Although the group's structures and psychic processes obey general mechanisms that are characteristic of all products of the unconscious, some of them are specific to the group situation, as witness the group illusion. The model of a group mental apparatus proposed by René Kaës (1976) describes a mechanism for linking and transforming the psychic structures committed to the group by its members. This mechanism produces the group's psychic reality and processes it within the group. In his 1993 book *Le Groupe et le Sujet du groupe* (The group and the group subject), Kaës emphasizes the role of repression, denial, or rejection, and the unconscious alliances underlying the formation of the psychic reality of the group and its members.

RENÉ KAËS

See also: Anzieu, Didier; Balint group; Bion, Wilfred Ruprecht; Collective psychology; Family; Family therapy; Foulkes (Fuchs), Sigmund Heinrich; Group phenomenon; *Group Psychology and the Analysis of the Ego*; Group psychotherapy; Identification; Primitive horde; Second World War: The effect on the development on psychoanalysis; Sociology and psychoanalysis/sociopsychanalysis.

### **Bibliography**

- Anzieu, Didier. (1975). *The group and the unconscious*. (Benjamin Kilborne, Trans.). London and Boston: Routledge & Kegan Paul, 1984.
- Bion, Wilfred Ruprecht. *Experiences in groups*. London: Tavistock Publications, 1961.
- Foulkes, Sigmund Heinrich. *Therapeutic group analysis*. New York: International Universities Press, 1964.
- Kaës, René. *Le groupe et le sujet du groupe*. Paris: Dunod, 1993.
- Neri, Claudio. (1997) *Group*. (Christine Trollope, Trans.). Rome, London and Philadelphia: Jessica Kingsley.

Pontalis, Jean-Bertrand. (1963) *Le petit groupe comme objet*. In *Après Freud*. Paris: Gallimard, 1968.

## **GROUP PHENOMENON**

Wilfred R. Bion's work on group dynamics, developed in particular in his 1961 book *Experiences in Groups*, established a fundamental difference between individual and group mentalities; individual and group psychoanalysis must be treated differently, even though "the two methods provide the practitioner with a rudimentary binocular vision" and are "dealing with different facets of the same phenomena" (p. 8). In a group, individuals undergo a regression to defend themselves against the conflicts provoked or revealed by their participation in the group. This regression is expressed through formation of a "group mentality"—a unanimous expression of the group's will, a defensive system of avoidance and denial, and a common repository for anonymous contributions that the individual members split off or disavow (such as their hostility toward the therapist). The individual contributes to the group mentality but is nevertheless situated in opposition to it, since it threatens the satisfactions of the individual's needs as a group animal. The group responds to this threat by means of a compromise formation, the "group culture."

Bion emphasizes the importance of the work (W) group: the mental functioning (and not the individual participants) necessary to perform the joint task that the group has implicitly taken on. The work group must take reality into account ("reality testing"); its characteristics "are similar to those attributed by Freud [in *Beyond the Pleasure Principle*, 1920g] to the ego" (p. 143). The work group's methods are "rational, and therefore, in however embryonic a form, scientific" (p. 143), and they depend upon cooperation among the group's members, training, and the type of mental development defined by the aptitude for learning through experience. The members must undergo development rather than rely on magical efficacy.

The work group has come together to undertake a creative task, such as, to resolve the psychological problems of its members. However, the work group's rational intentions are, as a rule, impeded by obscure and chaotic emotional forces, which produce anomalies in the group's mental activity. These emotional forces are given coherence by the supposition that the group is acting as if its goal were motivated by a basic

assumption. In contrast with the requirements of the work group, participation in an activity that depends on a basic assumption does not call for any training, experience, or individual mental development; it is instantaneous, inevitable, and instinctive, and it actually manifests an aggressive refusal to work or develop. The basic-assumption group does not make rational use of verbal communication; it does not develop language as a method of thought and instead uses words as a mode of action. The inability to form and use symbols, observed by Melanie Klein (1930) in an autistic child, extends to all individuals functioning as members of a basic-assumption group. The members seemingly wish to replace any process of elaboration with the ability to know magically, by instinct, without any development or learning, how to live and act in the group. Activity that depends on a basic assumption does not require any ability to cooperate on the part of the individual, but it supposes that the individual—unless he or she is schizophrenic—possesses a “valency,” defined as “the individual’s readiness to enter into combination with another in making and acting on the basic assumption” (p. 116). The hostile reaction against any process of development in the basic-assumption mentality indicates that time has no place in it, and interpretations of disturbed temporal relations elicit feelings of persecution. In fact, the basic-assumption group only exists outside of time; it neither disperses nor comes together. Inevitably, the basic-assumption group develops an intolerable frustration that can only be addressed by an awareness of the passage of time, and to counter this frustration, the group immediately and automatically puts into play behaviors and beliefs that define itself. Because he considered this theoretical model of basic assumption to be inadequate, Bion elaborated it by describing its modes of dependency, fight-flight, and pairing.

Sigmund Freud considered the Catholic Church and the army to be groups faced with the basic assumptions of, respectively, dependency (*baD*) and fight-flight (*baF*)—in effect, “specialized work groups.” One of the goals of these groups is to prevent the basic assumption from being translated into action, which would require work-group methods to remain in contact with reality. The third type of specialized work group, involved in the basic assumption of pairing (*baP*), Bion associated with the aristocracy and its preoccupation with reproduction and good genes. However, the psychoanalytic method itself

constitutes a work group of two people centered around the basic assumption of pairing, which endows the transference with its characteristic features and only accounts for the link between individuals in terms of the libido, the latter designating only the specific quality of the valency characteristic of the pairing group.

A basic assumption can only be manifested in alternation with the two others. When one is active, it relegates the others to prototypes and confines them to the sphere of what Bion calls the “proto-mental.” In this sphere, the physical, the psychological, and the mental are not differentiated and the emotional components are blurred together because they have not yet come into being on the psychological plane. The group expresses (proto-) emotions from this sphere by putting into play a basic assumption, and the psychological expression of these emotions reinforces, invades, or dominates the group’s mental life. The proto-mental phase in the individual is only a part of the proto-mental system. Proto-mental phenomena cannot be understood solely as functions of the individual, but must be studied within the group. Somatic illnesses can be manifested in the individual, but their full context is in the relationship between the individual and the active basic-assumption group and in the proto-mental phases of the two other basic assumptions. The basic-assumption group that sweeps aside the essential part of individual mentality still operant in the work group thus expresses, on a level that is more neurophysiological than psychological, the primitive parts that live a group life within each individual.

BERNARD DEFONTAINE

*See also:* Family therapy; Group analysis.

### **Bibliography**

- Bion, Wilfred R. (1961). *Experiences in groups*. London: Tavistock.
- . (1970). *Attention and interpretation*. London: Tavistock.
- Grinberg, León; Sor, Darío; and Tabak de Bianchedi, Elizabeth. (1993). *New introduction to the work of Bion* (rev. ed.). Northvale, NJ: Jason Aronson.
- Meltzer, Donald. (1986). The proto-mental apparatus and soma-psychotic phenomena. In *Studies in extended meta-psychology*. London: Clunie Press.

Pines, Malcolm. (Ed.). (1985). *Bion and group psychotherapy*. London: Routledge.

## **GROUP PSYCHOLOGY AND THE ANALYSIS OF THE EGO**

Sigmund Freud's second essay, after *Totem and Taboo* (1912–13a), on collective psychology, *Group Psychology and the Analysis of the Ego* is perhaps his fundamental work on that topic. He began contemplating the project in 1919: "I had not only completed the draft of 'Beyond the Pleasure Principle' . . . but I also took up the little thing about the 'uncanny' again, and, with a simple-minded idea [*Einfall*], I attempted a P∇ foundation for group psychology," he wrote to Sándor Ferenczi on 12 May 1919 (Freud and Ferenczi, Letter 813, p. 354). His progress was slow; a first version was finished in September 1920, and the final version was finished in March 1921. It was published that summer. The close relationship between the discovery of dynamics operating in large dimensions—the theory of the life and death instincts, advanced in *Beyond the Pleasure Principle* (1920g)—and the possibility of reconceptualizing group psychology is noteworthy.

In contrast to *Totem and Taboo*, where Freud was applying psychoanalytic ideas to the psychology of groups and simultaneously acknowledging the differences between psychoanalysis and anthropology, here the brief and magisterial introductory chapter makes the claim that group psychology is part of psychoanalysis. Next he tackles a fundamental problem not elaborated in *Totem and Taboo*: What is the mental dynamic that holds together the individuals in a group, creates the group's forms, ensures its continuity and stability, or causes its disappearance? In other words, what is the morphodynamics of groups? Repeating a significant move in psychoanalysis, his abandonment of hypnosis, Freud proposed that the libido accounts for group morphodynamics. He accomplished this epistemological operation in three chapters, borrowing from Gustave Le Bon and William McDougall to describe the prevalence of the primary processes in ephemeral groups.

Freud refined his proposal by showing how two groups, the church and the army, can come apart—in their different ways—through the loss of libidinal bonds to the leader or among members, and how, in keeping with psychoanalytic dynamics, only the power

of love is capable of overcoming the narcissism and hatred that distance us from one another.

It remained to identify the psychic formations that ensure group cohesion. This is the topic is addressed in the next three chapters, where, for the first time, Freud studied in detail the various known identificatory processes and distinguished the ego's identifications from those of the ego ideal. Hence his statement: "A primary group . . . is a number of individuals who have put one and the same object in the place of their ego ideal and have consequently identified themselves with one another in their ego" (p. 116). This statement holds true for passionate love and the hypnotic state, which he had used to shed light on the identificatory processes. Freud then verified its validity in the case of the primitive horde, as a structure, as discussed in *Totem and Taboo*. In the course of his discussion, the generic quality of alienation and submission inherent in group membership is brought to light. A final chapter sharpens the distinction between ego and ego ideal, a distinction that provides an opening for psychoanalytic investigation of the narcissistic psychoses.

In important supplements to this work Freud distinguished three paradigmatic forms and dynamics of groups, based on the degree of the weakening of the ego ideal and the ego that they impose: the horde, the matriarchy, and the totemic clan. He specified that the level of elaboration allowed to groups excluded the thinking of sexual difference. He proposed that the earliest individual psychology in which the ego ideal does not appear in weakened form is that of the poet telling the totemic clan the lie that explains their origins: "the myth, then, is the step by which the individual emerges from group psychology" (Postscript, p. 136). He also examined the relationship between direct sexual instincts and sexual instincts whose aim is inhibited, with only the latter being mobilized and tolerated by social bonds.

The notion of the intrinsic relationship between individual and group psychology—which Freud sustained throughout his work—appears the most clearly in this essay. Freud's bringing to light of the libidinal morphodynamics of groups made possible some fundamental work on identifications, the ego ideal, and the ego and narcissism that would be continued in *The Ego and the Id* (1923b). However, the mode of articulation of object relations and identifications remained enigmatic, in part. The relevance of the three forms and paradigmatic dynamics proposed is unquestionable.

We can assume that these are deployed in every real human group, and that they are constantly in conflict. It should be noted that the horde of *Totem and Taboo* and that of *Group Psychology and the Analysis of the Ego* do not have the same status: The first is mythic and structural, while the second is actual and is endowed with active libidinal dynamics. The essay's lack of resonance among psychoanalysts, with regard to Freud's ideas about group psychology, can be explained by the fact that the majority of psychoanalysts after Freud, when working on groups, have hypothesized oedipal moments in them. Dealing with "the analysis of the ego," which has been referred to frequently, is another matter altogether.

At the beginning of the essay Freud made clear that he was working only on the libidinal dynamics involved in group cohesion. Three parameters were excluded: the influence of external reality on groups, the influence of "great men" on their level of development, and finally, an economic assessment of bonds and the role of hatred. This work was to be carried out in part in *Civilization and Its Discontents* (1930a [1929]) and then in *Moses and Monotheism* (1939a [1934–1938]).

MICHÈLE PORTE

See also: Collective psychology.

### Source Citation

Freud, Sigmund. (1921c) *Massenpsychologie und Ich-Analyse*. Leipzig-Vienna-Zürich: Internationaler Psychoanalytischer Verlag; *GW*, XIII: 71–161; Group psychology and analysis of the ego. *SE*, 18: 65–143.

### Bibliography

Freud, Sigmund. (1912–13a). Totem and taboo. *SE*, 13: 1–161.

——— (1923b). The ego and the id. *SE*, 19: 1–66.

——— (1930a [1929]). Civilization and its discontents. *SE*, 21: 57–145.

——— (1939a [1934–38]). Moses and monotheism: three essays. *SE*, 23: 1–137.

Freud, Sigmund, and Ferenczi, Sándor. (1992–2000). *The correspondence of Sigmund Freud and Sándor Ferenczi, Vol. 2, 1914–1919*. (Ernst Falzeder and Eva Brabant, Eds.; Peter Hoffer, Trans.). Cambridge and London: The Belknap Press of Harvard University Press, 1966.

Kaës, René, and Anzieu, Didier. (1976). *Chronique d'un groupe, le groupe du 'Paradis perdu': observation et commentaires*. Paris: Dunod.

Mitscherlich, Alexander. (1963). *Society without the father: A contribution to social psychology*. (Eric Mosbacher, Trans. New York: Schocken Books, 1970.

Moscovici, Serge. (1981). *The age of the crowd: A historical treatise on mass psychology*. (J.C. Whitehouse, Trans. Cambridge (Cambridgeshire) and New York: Cambridge University Press.

---

## GROUP PSYCHOTHERAPIES

The notion of group psychotherapies encompasses a considerable number of techniques and different theoretical points of view. Strictly speaking, group psychotherapy is a method for treating psychopathology and its concomitant suffering by means of the specific action of the group's processes on the individuals who comprise it. There is also a model of group psychotherapy that seeks to treat the group as a specific whole. To accomplish its therapeutic aims and bring about the corresponding changes in personality, group psychotherapy mobilizes in the participants the psychological exploration and work that ensues necessarily as a result of the development of intersubjective and transsubjective links. Various appropriate mechanisms are directed toward this end.

This method of psychotherapy is probably the oldest form of mental and psychosomatic care. Treatment regimens practiced in the Asclepion at Pergamon (Bergama) included group sessions of dream interpretation, as the ancient writings of Aelius Aristides reveal. However, the term "group psychotherapy" is recent: It was introduced by Jacob Moreno around 1930. Various attempts had been made prior to that, from Franz von Mesmer's tub to the explorations of J. H. Pratt (1905) or Trigant Burrow (1914). On the eve and at the beginning of the Second World War, Kurt Lewin and his collaborators developed the basics of group dynamics, based on Gestalt theory, observations of experimental groups, and group training programs. Siegmund Foulkes and Wilfred R. Bion established the groundwork for group analysis and psychoanalytic group psychotherapy. During the 1950s and 1960s this trend saw a remarkable upsurge in the United States, Latin America (Enrique Pichon-Rivière, José Bleger), and in Europe, notably in Great Britain, France, and Italy.

There is considerable variation among the theories, practical techniques, and goals of group psychotherapies, but a certain number of characteristics are common to all its forms. The group is composed of a relatively small number of participants (from three to about a dozen) who come together for a limited time. The restricted size of the group enables each of its participants to perceive and enter into relationship with each of the others; the time limitation, whether or not it is predetermined (long-term groups, short-term therapies, groups that gradually become more open), makes it possible to work with the resistance effects provoked by the group's institutionalization.

Several combinable classification criteria can be used to distinguish different types of groups: monotherapy or cotherapy groups; groups centered on the group or on the individual; on speech or on nonverbal modes of expression (ergotherapies, art therapies, writing, music); on psychodramatic role-playing or on the body (bioenergy, primal scream, relaxation); on family relations (psychoanalytic and systemic family therapies); on instituted groups (therapy groups within institutions, therapeutic communities). Regardless of the form of communication used to put the therapeutic processes into play (words, screams, improvised or scripted role-playing, sculpting, painting, music, puppets), each theory has its own way of assessing the therapy's processes and effects.

According to the psychoanalytic conception, the group constitutes a staging ground for the externalization, figuration, and contention of pathogenic representations that are unacceptable in the intrapsychic space; it is a mechanism for linking and dynamic transformation of the formations and processes that cannot be internally bound without this detour through the work of intersubjectivity. Groups result in specific modes of transference and resistance. Interpreting these produces a reorganization of the psyche in its encounter with the object-based reality of others, with the prohibitions and founding statements of psychic life and of intersubjectivity. For its members, the group constitutes a powerful identificatory analysis; it generates creativity and the capacity for symbolization between intrapsychic and bodily reality and intersubjective and social reality. However, numerous clinical, methodological, and theoretical problems have yet to be worked out. Group psychotherapies are not a panacea. They require a personal demand and personal training; their effectiveness

depends on the specific indications, limits, and principles involved.

RENÉ KAËS

*See also:* Group phenomenon; Group analysis; Intersubjective/intrasubjective.

### **Bibliography**

- Bion, Wilfred Ruprecht. (1965). *Transformations: Change from learning to growth*. London: Tavistock Publications.
- Bleandonu, Gérard. (1991). *Les groupes thérapeutiques familiaux et institutionnels*. Paris: Presses Universitaires de France.
- Foulkes, Siegmund Heinrich. (1964). *Therapeutic group analysis*. New York: International Universities Press.
- Moreno, Jacob L. (1966). *The international handbook of group psychotherapy*. New York: Philosophical Library.
- Schneider, Pierre-Bernard. (1965–1972). *Pratique de la psychothérapie de groupe*. Paris: Presses Universitaires de France.

### **Further Reading**

- Brown, Dennis, and Zinkin, Louis. (Eds.) (1994). *The psyche and the social world: Developments in group-analytic theory*. London/New York: Routledge.

---

## **GROUPS/ENSEMBLE.** *See* Topology

---

## **GUËX, GERMAINE (1904–1984)**

Germaine Guex, a Swiss psychoanalyst and psychologist who was a teaching member of the Société suisse de psychanalyse (Swiss Psychoanalytic Society), was born in France in 1904 and died in Lausanne, Switzerland, in 1984. She studied psychology in Geneva and, after receiving her diploma from the Institut Jean-Jacques Rousseau, became Jean Piaget's assistant in the psychology laboratory. However, she was attracted to clinical work above all. In 1930 Guex was recruited by Dr. A. Répond, a psychoanalyst and director of the psychiatric clinic of the Swiss canton of Valais in Malévoz, to oversee a psychoanalytically inspired medical and psychological

unit, the first of its kind. This consultancy was geared toward children, parents, and teachers, and its work was both therapeutic and preventive.

During her years in Malévoz, Guex became acquainted with Sigmund Freud's work, especially through her connection with Dr. Répond, who was both a psychiatrist and, as a psychoanalyst, a member of the Société suisse de psychanalyse. In the 1940s she moved to Lausanne, where she practiced psychoanalysis and was active in developing psychoanalytic training in French-speaking Switzerland. She was the companion of the psychoanalyst Charles Odier.

In 1950 Guex published *La névrose d'abandon* (Abandonment neurosis), revised in 1973 and appearing in a second edition under the title *Le syndrome d'abandon* (The abandonment syndrome). In this book she focused on the intense emotional needs and lack of security of some patients, an aspect of pregenital development that can impede working through the Oedipus complex—a new approach at that time. She believed that psychoanalytic treatment could enable such patients to have a new type of emotional experience of the transference, more conscious than unconscious, based on listening, mutual trust, and stability in the analytic relationship. Only then, she believed, could oedipal issues be analyzed. Because of the importance of its topic, *La névrose d'abandon* established Guex's reputation and has been translated into several languages.

JEAN-MICHEL QUINODOZ

See also: Abandonment; Switzerland (French-speaking).

### **Bibliography**

- Guex, Germaine. (1950). *La névrose d'abandon*. Paris: Presses Universitaires de France. (2nd ed.: *Le syndrome d'abandon*, 1973.)
- Quinodoz, Jean-Michel. (1993). *The taming of solitude: separation anxiety in psychoanalysis* (Philip Slotkin, Trans.). London: Routledge.
- Roch, Marcel. (1980). Á propos de l'histoire de la psychanalyse en Suisse romande. *Bulletin de la Société suisse de psychanalyse*, 10, 17–30.

---

## **GUILBERT, YVETTE (1867–1944)**

A French actress, singer and storyteller, whose repertoire ranged from medieval ballads to suggestive popular songs, Yvette Guilbert shared with Sigmund

Freud a friendship based on mutual admiration. Born Emma Laure in Paris on January 20, 1867, she died in Aix-en-Provence on February 3, 1944.

From a provincial family, her parents settled in Paris shortly before her birth. Her mother Albine owned a boutique, while her father, Hippolyte, a bon vivant who liked spending money in cabarets and enjoyed the company of women, sometimes brought her with him to the café-concerts, where she showed precocious singing talent. Seamstress, shop girl, and model, at age sixteen Guilbert came to the notice of Charles Zidler, later to become director of the Moulin Rouge, who introduced her to the world of show business.

After performing for a time in Parisian theaters, Guilbert sang at the Eldorado in 1890, then at the Moulin Rouge, the Divan Japonais, and other venues. As a storyteller and singer with an inimitable voice, Guilbert crafted in song the Paris of Toulouse-Lautrec—who made several famous sketches of her.

On June 22, 1897, Guilbert married Max Schiller, a Viennese biologist whom she met during one of her tours in New York. After the First World War, she appeared in a number of films and developed a new repertoire based on her research into the history of old French songs and medieval ballads, which she collected and published. She also wrote three volumes of memoirs: *La Chanson de ma vie* (1927), *La Passante émerveillée* (1929), and *Mes lettres d'amour* (1933).

On the advice of Madame Charcot, wife of the famous neurologist, Freud heard Guilbert perform for the first time in Paris in August 1889, while attending the First International Congress of Experimental and Therapeutic Hypnotism. Thereafter he never missed her concerts when she performed in Vienna. Eventually Guilbert and Freud enjoyed a friendly correspondence. In 1931, in reply to one of her letters, Freud wrote that her interpretive artistry surely arose from “repressed desires and traits that haven't had a chance to develop.” Guilbert was furious and rejected the explanation of “her very dear friend.” A few years later, however, in the daily newspaper *Ce Soir* (January 14, 1938), Guilbert wrote an article, “The Actor's Complex,” in which she employed the Freudian theories she had previously rejected.

Her husband's niece, Eva Rosenfeld, became a well-known psychoanalyst as well as a friend and colleague of

Anna Freud, with whom she worked at the Hietzing Schule, which she co-directed. At a musicale presented by Marie Bonaparte in Paris in 1938, during the XV International Congress of Psychoanalysis, Guilbert performed Freud's favorite song, "Dis-moi que je suis belle."

JEAN-PIERRE BOURGERON

See also: Burlingham-Tiffany, Dorothy; France; Hietzing Schule/Burlingham Rosenfeld School.

### **Bibliography**

- Brécourt-Villars, Claudine. (1988). *Yvette Guilbert l'irrespectueuse*. Paris: Plon.
- Freud, Sigmund. (1960a [1873–1939]). *Letters of Sigmund Freud, 1873–1939*. (Ernst L. Freud, Ed.; Tania and James Stern, Trans.). London: Hogarth Press.
- Guilbert, Yvette. (1902). *La vedette*. Paris: H. Simonis Empis.
- . (1926). *Autre temps, autres chants*. Paris: Robert Laffont.
- . (1992). *47 enregistrements originaux de 1897 à 1934*. Paris: E.P.M.
- Knapp, Bettina, and Chipman, Myra. (1964). *That was Yvette: The biography of the great diseuse*. New York: Holt, Rinehart & Winston, 1964).

---

## **GUILT, FEELING OF**

Guilt represents a sensation of intrapsychic tension, sometimes linked to apprehension of a catastrophic threat to oneself. It may also be manifest as humility, suffering, the need for punishment, remorse, and feelings of inadequacy.

According to Jean Laplanche and Jean-Bertrand Pontalis (1968), the term describes an emotional state that arises in consequence of some action that the subject considers reprehensible; it may also refer to a vague feeling of personal unworthiness, unconnected to any particular act.

The "sense of guilt" appeared for the first time in Freud's work in his article, "Obsessive Actions and Religious Practices" (1907b); however, he had previously suggested its outlines in the second section of his "The Neuro-Psychoses of Defence." (1894a) Freud distinguished two sources of the sense of guilt: fear of authority and fear of the superego. The former

compels renunciation of some instinctive pressure or action, while in the latter, internalization of parental authority initiates development of the superego. One of the functions of this agency (the superego), which is responsible for the evaluation and judgment of the actions of the ego, is known as moral conscience (1923b). Aggression stemming from this moral conscience prolongs and intensifies the aggression experienced from authority. Under the influence of the sense of guilt, the ego submits to the superego's demands, out of fear of losing its affection and protection. According to Freud, there is a link between the sense of guilt and the Oedipus complex.

Anxiety occasioned by loss (or potential loss) of the loved object is not the only manifestation of the sense of guilt. There is also the potential for psychic pain and suffering; excessive humility; repeated failures and regrets; constant asking for penitence, expiations, and renunciation; suicidal ideas; and the tendency toward self-punishment.

Melanie Klein (1948), like Freud, also saw a direct relationship between the sense of guilt and fundamental ambivalence arising from the life and death instincts. She stressed that this feeling not only appears in the oedipal conflict, but also in the very earliest relationships with the nourishing mother. In her description, damaged intrapsychic objects become persecutors.

In *Civilization and Its Discontents* (1930a), Freud described how the sense of guilt, together with the methods and mechanisms used to struggle against it, influence the individual's relationships, not only with their immediate family, but also other relationships within the larger social group, and even with civilization as a whole. One of the principal aims of psychoanalysis is therefore to understand how patients manage their guilt, for example, to understand the extent to which they can accept ambivalence and responsibility in the face of instinctual strivings and the feelings that generate guilt. The discovery that patients harbor feelings of both love and hate for their parents underscores the importance of guilt as a nodal area of personality development. In the first years of life, the specific ways that children respond to guilt may predispose them to neurosis and mental instability, but may also prove to be a source of success and fulfillment.

Klein (1945/1975), in opposition to Freud, attempted to show, through observation of children in analysis, that the superego emerges much earlier than Freud suggested. According to her views, the Oedipus

complex also appears much earlier, during the first six months of life. The essential nature of the sense of guilt resides in the young child's impression that its own experience of aggressive instincts have caused hurt to the love object. The desire to undo or to repair this damage derives from the sense of guilt.

To the extent that guilt may be said to reflect, or result from, discordance between the ego and superego, emergence of the latter implies the ineluctable appearance of the sense of guilt.

LEÓN GRINBERG

*See also:* Criminology and psychoanalysis; Death instinct (Thanatos); "Dostoyevski and Parricide"; Guilt, unconscious sense of; Law and psychoanalysis; Melancholy; Moral masochism; Need for punishment; Self-punishment; Superego.

### **Bibliography**

- Freud, Sigmund. (1894a). The neuro-psychoses of defence. *SE*, 3: 41–61.
- . (1907b). Obsessive actions and religious practices. *SE*, 9: 115–127.
- . (1923b). The ego and the id. *SE*, 19: 1–66.
- . (1930a). Civilization and its discontents. *SE*, 21: 57–145.
- Klein, Melanie. (1948). A contribution to the theory of anxiety and guilt. *International Journal of Psycho-Analysis*, 29, 113–123.
- . (1975). The Oedipus complex in the light of early anxieties. *The writings of Melanie Klein* (Vol. 3, 1946–1963). London: Hogarth. (Reprinted from *International Journal of Psycho-Analysis*, 26 (1945), 11–33.)
- Laplanche, Jean; and Pontalis, Jean-Bertrand. (1973). *The language of psycho-analysis*. New York: Norton, 1973.

### **Further Reading**

- Pulver, Stanley. (1999). Shame and guilt: a synthesis. *Psychoanalytical Inquiry*, 19, 388–406.
- Sandler, Joseph, and Sandler, Anne-Marie. (1987). Past unconscious, present unconscious, and the vicissitudes of guilt. *International Journal of Psychoanalysis*, 68, 331–342.

## **GUILT, UNCONSCIOUS SENSE OF**

The unconscious sense of guilt is an ego state resulting from conflict between the aims of the superego and those of the ego.

As a psychoanalytical term, according to Jean Laplanche and Jean-Bertrand Pontalis (1973), the "unconscious sense of guilt" developed a more specific meaning over time than when it was first used simply to designate a feeling in the unconscious aroused by an act considered reprehensible. Its current definition implies an unconscious relationship between the ego and superego expressed in subjective phenomena from which, in extreme instances, any conscious perception of guilt is entirely absent.

The term itself appeared for the first time in Sigmund Freud's article "Obsessive Actions and Religious Practices" (1907b). "We may say that the sufferer from compulsions and prohibitions behaves as if he were dominated by a sense of guilt, of which, however, he knows nothing, so that we must call it an unconscious sense of guilt, in spite of the apparent contradiction in terms" (p. 123). However, the basic idea had been adumbrated much earlier, in the second part of Freud's "The Neuro-Psychoses of Defence" (1894a).

In accepting the hypothesis that the sense of guilt arises simultaneously with the gradual development of the superego, it is important to stress that they both imply a social dimension, and that the superego also owes its existence to external factors and represents the demands of society to the ego. In addition, the superego not only frustrates certain tendencies of the ego, but also can divert aggression at it. When it does so, it manifests as a repetitive sense of culpability and expiation. In addition, as Freud wrote in *The Ego and the Id* (1923b), "One may go further and venture the hypothesis that a great part of the sense of guilt must normally remain unconscious, because the origin of conscience is intimately connected with the Oedipus complex, which belongs to the unconscious" (p. 52).

The sense of guilt appears to dominate instinctual life not only by acting to deny gratification, but also by leading to an increase in libido and thus the provocation of masochistic pleasure. Psychoanalysts see moral masochism as an expression of an unconscious sense of guilt.

Unconscious guilt is one of the most powerful factors in the gratification of passive libidinal wishes. Narcissistic patients should be helped to acknowledge the unconscious self-criticism and guilt that underlie their hostile demands for love. They must come to see how they project their thoughts and attitudes in order to regain self-esteem. What is in fact a deficiency of the superego is largely manifested as self-destructive



refusal to acknowledge guilt, thereby provoking an obvious disorder of ego functioning.

Trying to help such patients become aware of their unconscious guilt reveals characteristic patterns. One often encounters solid resistance to acknowledging guilt or even accepting its existence, and frequently such patients use projection as a defense. An intense battle is waged with the aim of warding off unconscious guilt, of keeping it silent and hidden. Analysis of dreams may be useful achieving a degree of acceptance.

Inasmuch as unconscious guilt acts as a form of “signal anxiety,” we might expect it to produce defenses against a subject’s wishes. This indeed turns out to be the case, and the inhibitions one observes are its clinical manifestations, seen by some as representing a “signal function” that announces the presence of guilt. But the most important characteristic of the unconscious sense of guilt is that it deploys defenses against passive libidinal wishes, in contrast to guilt caused by active and aggressive libidinal aims.

The origin and nature of unconscious guilt, and the way in which it affects psychological development are both unresolved issues. Some psychoanalytical tendencies are distinguished by the treatment techniques they employ to deal with the sense of guilt. Some analysts focus interpretatively on the necessity to “liberate” the patient from guilt, which they consider pathological and to which the patient is seen as submitting out of masochism. Other analysts, in sharp contrast, believe that the denial of guilt is central to all neurotic conflict, and that guilt itself is due to aggressive fantasies against objects. This controversy arises from a conflation of two distinct ideas.

Grinberg (1965), from a Kleinian perspective, has suggested distinguishing “persecutory guilt” from “depressive guilt.” This distinction permits a better understanding of the dynamic of the sense of guilt and thus fosters a broader understanding of the content and quality of object relations, as well as reactions to different stimuli and the normal or pathological process of mourning.

Persecutory guilt appears very early in life, and is associated with a weak and immature ego. It develops in parallel with the anxieties of the paranoid-schizoid position, or in the wake of some frustration or of a failure of depressive guilt. Despite its early appearance, persecutory guilt has an important influence upon subsequent psychological growth and plays an important role in the development both of inhibitions and masochistic attitudes and behaviors. Despair, resentment, fear, pain and self-reproach are the symptoms of persecutory guilt, as are a compulsion to repeat and a tendency to “act out.” Extreme cases occur with schizophrenia, melancholia and pathological mourning.

To the extent that persecutory guilt diminishes, pain and suffering caused by object loss will increase, along with a more or less depressive manifestations. Concern for self and object, responsibility and, in the final analysis, the capacity for reparation will also increase. These feelings represent a form of depressive guilt which predominates in the normal process of mourning and in activities requiring sublimation.

LÉON GRINBERG

*See also:* Guilt, feeling of.

### **Bibliography**

- Freud, Sigmund. (1894a). The neuro-psychoses of defence. *SE*, 3: 41–61.
- . (1907b). Obsessive actions and religious practices. *SE*, 9: 115–127.
- . (1923b). *The ego and the id*. *SE*, 19: 1–66.
- Grinberg, Léon. (1965). Deux sortes de culpabilité: leurs relations avec les aspects du deuil normal et pathologique. *Revue française psychanalyse*, 29, 2–3.
- Laplanche, Jean, and Pontalis Jean-Bertrand. (1973). *The language of psycho-analysis* (Donald Nicholson-Smith, Trans.). W. W. Norton: New York. (Original work published 1971)

# H H

## **HALBERSTADT-FREUD, SOPHIE (1893–1920)**

The fifth child of Sigmund and Martha Freud, Sophie Halberstadt-Freud was born on April 12, 1893, in Vienna, and died on January 25, 1920, in Hamburg. Freud's "Sunday's child" was named after Sophie Schwalb, the niece of Samuel Hammerschlag, Freud's Hebrew teacher. Admired by her father, and her mother's favorite, Sophie only succeeded in getting out of the house by the sudden announcement of her engagement in 1912. On July 20, Freud wrote to his sister Mitzi, "His name is Max Halberstadt, he's thirty years old, is a distant relative of our family from Hamburg. He's very serious, inspires confidence, and both of them seem to be in love with one another. The terms are appropriate and bourgeois. No wealth, no distinction. Something we would not be pleased with in the case of Max Halberstadt." Engaged on July 28, they were married on January 14, 1913, in Hamburg.

On March 11, 1914, Ernst Wolfgang was born. The child's spool game fascinated Freud and provided the example of repetition in "Fort-da" (1920g, chap. 2). On September 22, 1914, Freud wrote to Karl Abraham, "My grandson is a charming little fellow, who manages to laugh so engagingly whenever one pays attention to him; he is a decent, civilized being, which is doubly valuable in these times of unleashed bestiality. A strict upbringing by an intelligent mother enlightened by Hug-Hellmuth has done him a great deal of good." Later, "little Ernst" would be analyzed by his aunt Anna Freud (Roazen, 1933), who hesitated to adopt him but made him her legal heir. Emigrating to Great Britain in 1938 after having traveled to Palestine, Moscow, and South Africa, he was analyzed by Willy

Hoffer. After marrying Irene Chambers in 1945, he himself became a psychoanalyst and, under the name Ernst W. Freud, practiced in Germany, returned to Great Britain, and finally returned to Germany.

On December 8, 1918, Heinz Rudolf, called "Heinele," was born in Schwerin.

Sophie Halberstadt-Freud died on January 25, 1920, from complications resulting from the Spanish flu that ravaged Europe. Freud wrote to Pastor Pfister on January 27:

This afternoon we received the news that our sweet Sophie in Hamburg had been snatched away by influenzal pneumonia, snatched away in the midst of glowing health, from a full and active life as a competent mother and loving wife, all in four or five days, as though she had never existed. Although we had been worried about her for a couple of days, we had nevertheless been hopeful; it is so difficult to judge from a distance. And this distance must remain distance; we were not able to travel at once, as we had intended, after the first alarming news; there was no train, not even for an emergency. The undisguised brutality of our time is weighing heavily upon us. Tomorrow she is to be cremated, our poor Sunday child! . . . Sophie leaves two sons, one of six, the other thirteen months, and an inconsolable husband who will have to pay dearly for the happiness of these seven years. The happiness existed exclusively within them; outwardly there was war, conscription, wounds, the depletion of their resources, but they had remained courageous and gay. I work as much as I can, and am thankful for the diversion. The loss of a child seems to be a serious, narcissistic injury; what is known as mourning will probably follow only later.

He wrote of this “irreparable narcissistic wound” in a letter to Sándor Ferenczi on February 4. On April 11, 1929, he consoled Ludwig Binswanger, who was suffering from a similar loss: “We know that the acute sorrow we feel after such a loss will run its course, but also that we will remain inconsolable, and will never find a substitute. No matter what may come to take its place, even should it fill that place completely, it remains something else. And that is how it should be. It is the only way of perpetuating a love that we do not want to abandon.”

Early on, commentators claimed that this grief inspired the introduction of the death impulse in Freudian theory. In fact, the war of 1914–1918 and the thoughts it inspired in Freud were sufficient for this change in his thinking (see the discussion in “Why War,” 1933b), but the story continues to be repeated. By December 18, 1923, Freud had indicated to Fritz Wittels, who repeated this “interpretation” in his biography, that the book had been written in 1919, while his daughter was still “healthy and flourishing” (this claim has been discussed and contradicted for some time by Ilse Grubrich-Simitis, 1993). In September he gave the manuscript to several friends in Berlin to read, including Karl Abraham. Concluding, he added, “Likelihood is not always truth.”

Similarly, it has for a long time been believed, wrongly, that the child with the spool was Sophie’s other son, Heinz Rudolf (Heinele), who had a tragic destiny. In 1922, taken in by his aunt Mathilde, he was, according to Freud (letter to Anna von Vest, November 14, 1922), “physically very fragile, truly a child of the war, but especially intelligent and endearing.” He died on June 19, 1923, from military tuberculosis.

On October 15, 1926, Freud wrote to Ludwig Binswanger, “For me, that child took the place of all my children and other grandchildren, and since then, since Heinele’s death, I have no longer cared for my grandchildren, but find no enjoyment in life either. This is also the secret of my indifference—it has been called courage—towards the threat to my own life.” On March 11, 1928, he returned to the subject in a letter to Ernest Jones: “Sophie was a dear daughter, to be sure, but not a child. It was only three years later, in June 1923, when little Heinele died, that I became tired of life permanently. Quite remarkably, there is a correspondence between him and your little one. He too was of superior intelligence and unspeakable spiritual

grace, and he spoke repeatedly about dying soon. How do these children know?”

ALAIN DE MIJOLLA

*See also:* *Beyond the Pleasure Principle*; Burlingham-Tiffany, Dorothy; Fort-da; Hollitscher-Freud, Mathilde; Hietzing Schule/Burlingham-Rosenfeld.

### Bibliography

- Grubrich-Simitis, Ilse. (1993). *Back to Freud’s texts: Making silent documents speak*. New Haven and London: Yale University Press.
- Roazen, Paul. (1993). *Meeting Freud’s family*. Amherst, MA: University of Massachusetts Press.
- Wittels, Fritz. (1923). *Sigmund Freud, his personality, his teaching, his school*. (E. and C. Paul, Trans.). London: Allen & Unwin.

---

### HALL, GRANVILLE STANLEY (1844–1924)

Psychologist, educator, and philosopher Granville Stanley Hall was born in Ashfield, Massachusetts, on February 1, 1844, and died on April 24, 1924 in Worcester, Massachusetts.

The son of Congregationalist farmers, he spent his adolescence in rebellion against the strict authority of his father, a model of moral and religious values. He attended Williams College and Union Theological Seminary before abandoning religion for the emergent discipline of psychology. During two trips to Europe, Hall familiarized himself with currents in philosophy, became conversant with the scientific trends in physiology and psychology, and studied with biologist and philosopher Ernst Haeckel. In 1878 at Harvard University he was awarded the first American doctorate in psychology by William James himself. In Leipzig during 1879–80, he also worked with Wilhelm Wundt, who was just then establishing the first laboratory of experimental psychology. There he participated in word association tests based on Francis Galton’s psychometric experiments, which Carl Jung would later modify to confirm Freud’s theory of neuroses in a laboratory setting.

After returning to the United States, in 1880 Hall began his career as an educator and psychologist, devoting himself to a systematic study of child and adolescent development. He edited several journals,

the most important of which was the *American Journal of Psychology*, which eventually became a forum both to disseminate his own ideas and to publish articles on psychoanalysis. He taught at Johns Hopkins from 1883, and his interest in the human sciences and in education led to his appointment as president of Clark University in 1888, where he was also professor of philosophy and psychology and launched more reviews, including the *Journal of Applied Psychology*. In 1892 he also served as president of the newly founded American Psychological Association.

In 1909, Hall invited Freud to deliver the series of lectures that launched the psychoanalytic movement in the United States. The correspondence between the two men, from 1908 to 1923, includes some thirty-one letters. For Hall, Freudian theory was a boon to the hereditarian approach to studying children and adolescents. Like Freud, with whose works he had been familiar since 1894, Hall was inspired by Charles Darwin's theory of evolution, and he shared a lively interest in understanding sexuality. He was electrified by Freud's lectures in Worcester, and believed that they reduced to ashes much of the flimsy theoretical structure upon which philosophically-based laboratory psychology of the time relied.

However, in a letter to Freud four years later (September 26, 1913) Hall indicated areas of skepticism and disagreement with psychoanalytic theory. Rather prophetically, he suggested that one day "specific [hereditary] influences" would be discovered to operate on individuals. He was also critical of extravagant use of sexual symbolism. Subsequently, he made it clear that he regarded as significant the contributions of Alfred Adler, who had rejected castration anxiety as central to the fears and anxieties of childhood.

Learning of Hall's friendly relationship with Adler, Freud wrote that he was sharply stung by what he viewed as a serious defection. However, Hall continued to support psychoanalysts in the American Psychopathological Association, and from 1917 to 1920 he served as president of the American Psychoanalytic Association. Several years later, responding to Freud's admonition that Adler's ideas were incompatible with psychoanalysis, Hall defended his eclecticism, suggesting that Freud should be more generous toward rebellious children of psychoanalysis like Adler and Jung.

Hall's autobiography, published in 1923, indicates that he tried self-analysis and underwent some

psychoanalysis; he was apparently disappointed with the results but did not disclose them. In general, while exasperated by religious and moral restrictions upon happiness and artistic creation, Hall hoped to protect the essential virtues of the ideology that he fought—the cult of work and the intricacies of moral conscience. The influence of psychoanalysis is perceptible in his 1904 two-volume work on adolescence and in his life of Jesus Christ, published in 1917.

Hall died from pneumonia at eighty years of age. He is generally considered, with William James, to be one of the founders of psychology as a scientific discipline in the United States.

FLORIAN HOUSSIER

*See also:* Clark University; *Five Lectures on Psychoanalysis*; North America; Ontogenesis; Psychology and psychoanalysis.

### **Bibliography**

- Esman, Aaron H. (1993). G. Stanley Hall and the invention of the adolescence. *Adolescent Psychiatry*, 19, 6–20.
- Hale, Nathan G. Jr. (1971). *Freud and the Americans: The beginnings of psychoanalysis in the United States*. New York: Oxford University Press.
- Hall, G. Stanley. (1923). *Life and confessions of a psychologist*. New York: Appleton.
- . (1904). *Adolescence: Its psychology and its relations to physiology, anthropology, sociology, sex, crime, religion and education*. New York: Appleton.
- . (1917). *Jesus, the Christ, in the light of psychology*. Garden City, New York: Doubleday.
- Houssier, Florian. (2003). G. S. Hall (1844–1924): un pionnier dans la découverte de l'adolescence. Ses liens avec les premiers pschanalystes de l'adolescent. *Psychiatrie de l'enfant*, 46, 655–668.
- Rosenzweig, Saul. (1992). *Freud, Jung, and Hall the king-maker: The historic expedition to America (1909)*. St. Louis: Rana House.

---

## **HALLUCINATORY, THE**

The basis for the transformational dynamics of representation-perception-hallucination, the hallucinatory register is a constant process of mental life, representing the instinctual impulse insofar as it is "pressure" (*Drang*) and movement (*Treiberegung*).

In noun form and detached from any psychiatric connotations, the term *hallucinatory* was introduced as a metapsychological notion in 1990 by César Botella and Sára Botella, in an attempt to broaden an analytic theory that was overly focused on the notion of representation, and that therefore could not explain certain analytic structures or why certain analytic treatments were doomed to failure.

Freud used the expression “hallucinatory satisfaction of need” throughout his writings, and he considered the hallucinatory a basic assumption governing mental life. However, he never really developed the idea.

The same was true of the post-Freudians. In “Le développement du sens de réalité et ses stades” (Stages in the development of the sense of reality; 1913), Sándor Ferenczi described a “hallucinatory stage” but did not explore it in depth. Wilfred Bion took an interest in the topic, but his notion of hallucinosis remained close to that of pathological hallucination. Jacques Lacan, in *Das Ding* (1959), hinted at a “fundamental hallucination,” but he did not develop this idea either.

André Green, in *The Fabric of Affect in the Psychoanalytic Discourse* (1973/1999) was indisputably the first to posit a hallucinatory formation, as a “negative hallucination” (the representation of the absence of a representation; this is a reverse configuration, whose opposite is hallucinatory realization). According to Green, hallucination was fundamental to the structure of the psyche. In “L’hystérie, unité et diversité” (Hysteria, unity and diversity; 1985), Augustin Jeanneau conceptualized a “hallucinatory position” with the value of a mental function.

The hallucinatory represents the instinctual impulse in the same way that affect represents qualitatively the quantity of the instinct, and the idea represents the instinct’s contents. It involves a process that is inseparable from the regressive pathway that opens up in dreams but that must be inhibited during the working hours in favor of ideation and perception.

This notion is indispensable to psychoanalytic practice. At certain times during the session, under the influence of a formal regression of thought, “accidents of thought” or a quasi-hallucinatory “work of representability” can unexpectedly occur in the analyst without his or her conscious awareness; this may be

the only way to gain access to the meaning of the patient’s unrepresentable material.

CÉSAR BOTELLA AND SÁRA BOTELLA

*See also:* Absence; Action-(re)presentation; Amentia; Experience of satisfaction; Fantasy; Idea/representation; “Metapsychological Supplement to the Theory of Dreams”; Negative hallucination; Negative, work of; Pleasure/unpleasure principle; Primary need; Reality principle; Reality testing; Representability; Subject’s desire; Wish-fulfillment; Wish, hallucinatory satisfaction of a; Word-presentation.

### **Bibliography**

- Botella, César, and Botella, Sára. (1990). La problématique de la régression formelle de la pensée et de l’hallucinatoire. In *La psychanalyse: Questions pour demain, colloque de la S.P.P.* Unesco, Paris: Presses universitaires de France.
- . (1992). Névrose traumatique et cohérence psychique. *Revue française de psychosomatique*, 2.
- . (2001). *La figurabilité psychique*. Lausanne and Paris: Delachaux & Niestlé.
- Green, André. (1999). *The fabric of affect in the psychoanalytic discourse* (Alan Sheridan, Trans.). London: Routledge. (Original work published 1973)
- Jeanneau, Augustin. (1985). L’hystérie, unité et diversité. *Revue française de psychanalyse*, 49 (1), 258–283.

## **HALLUCINOSIS**

“Hallucinosis” is a term coined by Wilfred Bion in “Transformations” (1965) to denote the mental state of the psychotic part of the personality. Psychotic panic is the experience, the O, which impels the personality to hallucinosis. Psychotic panic arises from a primitive disaster between infant and mother in which the infant’s emotional contents fail to find a container, that is to say, a mother with reverie. Undue envy and greed in the infant are significant factors in this disaster. In an effort to escape overwhelming anxiety, the infant evacuates ego functions capable of the experience of psychotic panic, along with other related contents, including space, time and meaning. Such events are in stark contrast to the normal situation where alpha-function creates a container for violent emotions.

In transformations in hallucinosis there is a failure of realistic projective identification; instead there is an

explosive projection in an unrestricted mental space. In a metaphor that has become well-known, Bion compares the emotional experience of psychotic space to surgical shock, in which the dilation of capillaries so increases the space in which blood circulates that the patient is at risk of bleeding to death in his own tissues.

In the mental space of hallucinosis, words and images float without limits, either as debris, or, in an attempt at synthesis, as conglomerates which are bizarre objects. Such beta-elements and bizarre objects indicate a place where the object should be, but, as the container is destroyed, is not. This place feels very threatening. In transformations in hallucinosis, sense organs, instead of being used for perception, become channels for the evacuation of unwanted mental products; the musculature is also used in this way in the form of acting out. Words, too, become vehicles of evacuation rather than conveyers of meaning. Manifest hallucinations may be visual, auditory, tactile, and olfactory. If the sensorial component has been violently fragmented or pulverized during its expulsion, the hallucinations of the psychotic patient will be evanescent or even what Bion calls "invisible."

Transformations in hallucinosis should be contrasted with transformations in thought. This contrast is of clinical importance. In the area of thought, frustration and the absence of the object facilitate the construction of symbols. In hallucinosis there are no symbols, only representations of concrete things for the psychotic part of the personality. A sentence uttered by a psychotic patient, though it may have the same words as a sentence uttered by a neurotic patient, has a different significance. As Leon Grinberg and others remark in their overall exposition, "... words like *yesterday*, *later*, or some years ago may not be representations but residues of destructive dispersing attacks on time." (1993, p. 94).

The psychotic patient believes that his method of transformation in hallucinosis is superior to transformations in thought in that his universe provides him with freedom from reality—its restrictions, its pains—especially of frustration and absence of the object, and its threats of panic and annihilation. In analysis, hallucinosis is viewed as especially superior to the transformations in thought offered by the analyst.

EDNA O'SHAUGHNESSY

*See also:* Bizarre object; Hallucinatory, the; Psychotic panic; Psychotic part of the personality; Transformations.

### **Bibliography**

Bion, Wilfred. (1965). *Transformations: Change from learning to growth*. London, Heinemann.

Grinberg, Leon; Sor, Dario; and Tabak de Bianchedi, Elizabeth. (1993). *New introduction to the work of Bion*. Northvale, NJ; London: Jason Aronson.

---

## **HAMLET AND OEDIPUS**

An original work of applied psychoanalysis, *Hamlet and Oedipus* was initially published in 1910 as an article in the *American Journal of Psychology* with the title "The Oedipus Complex as an Explanation of the 'Mystery of Hamlet.'" It was translated into German in 1911 in a brochure in the series *Schriften zur angewandten Seelekunde* as "Das Problem des Hamlet und der Oedipus Komplex."

In 1923 it appeared as the first chapter of *Essays in Applied Psychoanalysis* (Hogarth Press, London, 1964) as "A Psychoanalytic Study of Hamlet." In its current form the work appeared in 1949 as *Hamlet and Oedipus*, together with an essay on the interpretation of Hamlet, an article on "The Death of Hamlet's Father" signed by Jones, and an article by Ella Freeman Sharpe, "The Impatience of Hamlet," which had previously appeared in 1929 in the *International Journal of Psycho-Analysis*.

There are eight chapters in the book, which is an attempt to spread Sigmund Freud's ideas and improve the recognition of psychoanalysis as a science. With respect to Freud, aside from the theme of parricide, the author also discussed matricide, and the homosexual and homicidal nature of the son's aggression toward the father. Sharpe's essay continues Jones's work through reference to libidinal development, regression, and pregenital attachment, and shows how the difficult confrontation with the oedipal conflict results in procrastination and its transformation into blind action and violence.

FRANÇOIS SACCO

*See also:* Applied psychoanalysis and the interaction of psychoanalysis; Jones, Ernest; Eissler, Kurt Robert; Literary and artistic creation; Parricide; Phantom; *Ornicar?*; Shakespeare and psychoanalysis.

**Source Citation**

Jones, Ernest. (1949). *Hamlet and Oedipus*. London: Hogarth Press.

**HAMPSTEAD CLINIC**

Founded in London in 1951 by Anna Freud together with Helen Ross and Dorothy Burlingham, the Hampstead Clinic set out to provide therapy and assistance to families, to treat disturbed and handicapped children irrespective of their problems, social background or past history, and at the same time to offer aspiring analysts the most balanced and rich training possible. Anna Freud saw the Clinic as an opportunity to apply the particular psychoanalytic knowledge she had acquired in the area of child guidance.

Located at 31 Maresfield Gardens in Hampstead, London, the clinic began full operation only in 1952. It had many philanthropical supporters, notably the Field Foundation of Illinois, the Foundation for Research in Psychiatry, and the Yale Study Center. The establishment comprised six consulting rooms, a playroom, offices, a library, and a classroom for use in the training of therapists.

In addition to the treatment of children, simultaneous mother-and-child therapy was practiced under the supervision of Dorothy Burlingham. Burlingham also promoted the creation of an index that would record data gathered during child analysis, enter it on cards, and organize it thematically in close correlation with the analytic context and with what children revealed therein. Unconscious contents, anxieties, defenses, character traits, object-relationships, and manifestations of the transference were some of the themes serving as index headings. This classification system had its origins in the methods developed by Burlingham and Anna Freud when they directed the Jackson Nursery in Vienna and later the Hampstead War Nurseries in London.

For her part, Anna Freud perfected a diagnostic tool that later came to be known as the "diagnostic profile." This approach used a psychological questionnaire intended to generate diagnoses on the basis of information garnered from interviews with children and their families. The goal was to increase the reliability of child analysis while making it easier for analysts to take effective therapeutic action much earlier than had hitherto been possible.

The Hampstead Clinic soon achieved a fame that allowed its founders to undertake several pathbreaking experiments. In 1954, Burlingham started the analysis of a blind child, and this marked the beginning of a long collaboration between the clinic and the Royal National Institute of the Blind. She soon opened a nursery school for blind children in a house conceived by Ernst Freud and built in the garden of the main building. Later on, a Well Baby Clinic was set up in order to help mothers respond to the physical and emotional needs of their babies, and the observation of normal children became possible thanks to the institution of a kindergarten.

DELPHINE SCHILTON

See also: Burlingham-Tiffany, Dorothy; Childhood; Freud, Anna; Great Britain; Hietzing Schule/Burlingham-Rosenfeld; *Psychoanalytic Study of the Child, The*.

**HANDLING**

Handling is the way a mother manages the moment to moment physical care of her infant such that the baby gets to know his own body. It necessarily involves the mother and infant going on in a psychosomatic partnership; as if they formed one unit (Winnicott, 1962).

Donald Woods Winnicott presented his ideas of infant care and its relation to psychological development to the lay public in a series of radio broadcasts and child care journals (Winnicott, 1947). He gave detailed descriptions of what happens between the mutually adapted mother and infant, for example with breastfeeding or when a mother picks up her baby. In this paper Winnicott made his famous statement, "there is no such thing as a baby. . . . A baby cannot exist alone, but is essentially part of a relationship" (p. 88). The description of the mother's handling of her baby grew out of Winnicott's detailed observations of mother-infant interactions in his work as a pediatrician and later his psychoanalytic work with both child and adult patients. Mutually attuned and sensitive physical care of the baby gives the baby a sense of his own body: "an indwelling of the psyche in the soma" (1970). The mother approaches her baby and picks him up as if there is a person within the body she approaches. This concept is adapted to the quality of care enacted in psychoanalytic treatment. The mother

adapts herself to what the baby can understand, and to what the baby needs. Thus, Winnicott insisted that the mothering of one's own baby is a personal job, that no one else could do as well. The mother's handling of her own baby is so sensitive as to be unique.

The baby has no experience of being a baby, so it is dependent upon the mother's capacity to adapt to his needs in order to develop the experience of mutuality. The "good-enough mother" manages the baby's body and its needs in such a way that he comes to know his body—that there is an inside and an outside, a body schema integrated with his personal psychic reality, that is: "personalization."

PAUL CAMPBELL

*See also:* Breastfeeding; Good-enough mother; Holding; Integration; Maternal; Maternal care; Neutrality/benevolent neutrality; Object.

### **Bibliography**

Winnicott, Donald. (1964) Further thoughts on babies as persons. In his *The child, the family, and the outside world* (pp. 85–92). Harmondsworth, England: Penguin Books. (Original work published 1947)

———. (1965) Ego integration in child development. In his *The maturational processes and the facilitating environment* (pp. 56–63). London: Hogarth Press. (Original work published 1962)

———. (1970) The mother-infant experience of mutuality. In E. Anthony and T. Bender (Eds.), *Parenthood: Its Psychology and Psychopathology*. Boston: Little, Brown & Co.

———. (1989) On the basis for self in body. In C. Winnicott, R. Shepherd, and M. Davis (Eds.), *Psychoanalytic explorations*. London: Karnac. (Original work published 1971)

### **HAPPEL, CLARA (1889–1945)**

Clara Happel, a German psychoanalyst, was born on October 1, 1889, in Berlin. She committed suicide on September 16, 1945, in Detroit.

While studying medicine, Happel showed an early interest in psychoanalysis, and after settling in Frankfurt in 1921, she began analysis with Hanns Sachs. The same year Max Eitingon facilitated her admission to the Berlin Psychoanalytic Society. She

attended the Eighth International Congress in Salzburg in 1924, where Olga Székely-Kovacs drew her caricature. In 1925 in Berlin, Happel lectured on male homosexuality.

When the Berlin Psychoanalytic Society became the Deutsche psychoanalytische Gesellschaft (German Psychoanalytic Society) in 1926, Happel, with Karl Landauer, was appointed to head the Frankfurt branch. With Landauer, she participated in the foundation of the Southwest German Psychoanalytic Working Group, which operated from 1929 to 1933 and from which would emerge the Frankfurt Psychoanalytic Institute. In 1931 Happel moved to Hamburg, where with August Waterman she established a study group.

After Hitler came to power, Happel, a Jew, firmly advocated that Jewish members of the Deutsche psychoanalytische Gesellschaft resign in protest. Her motion was rejected at a meeting on November 18, 1933. This episode earned her the enmity of Ernest Jones, who perceived it as at odds with his efforts to mediate the situation and save psychoanalysis in Germany. As late as 1936 he was reluctant to allow her to join after her resignation in protest two years earlier. Anna Freud, however, opposed this restriction.

In January 1936, divorced from her husband (probably because he was not a Jew), Happel left Germany with her two children, emigrating first to Palestine and then to the United States, where she was welcomed by Sándor Radó. Within a year she was certified as training analyst. She joined the Chicago Psychoanalytic Society in 1938 but settled in Detroit, one of the developing outposts. In 1940, with Editha and Richard Sterba and Leo H. Bartemeier, Happel helped establish the Detroit Psychoanalytic Society and its training program, in which she taught, supervised, and lectured.

Happel remained close to fellow émigré analysts, welcoming them as she had been embraced when she arrived in the United States. At the beginning of World War II, she was affected by legal sanctions targeting "aliens" in the United States when a psychotic patient denounced her. She was arrested on the day after the attack on Pearl Harbor and detained for six weeks. Her correspondence with her children, who were then attending school in New York, reveals a life that was lonely, difficult, and sad.



Happel opened a practice in New York, which enabled her to spend more time with her married son. Yet despite this success, she became depressed, and her condition worsened at the end of World War II with revelations about the Nazi death camps and the use of atomic weapons on Japan. In addition, she found it difficult to adjust to life in a country where she was denied citizenship and not recognized as a medical doctor. She recalled Stefan Zweig's suicide several years earlier and ended her own life in September 1945.

Happel's published work includes a paper on substitute formation in masturbation and observations on a case of pederasty. Yet she is better remembered for her training and teaching activities in Germany and United States.

ALAIN DE MIJOLLA

*See also:* Sterba, Richard F.; Sterba-Radanowicz-Hartmann, Editha.

### **Bibliography**

- Eickhoff, Friedrich-Wilhelm. (1995). The formation of the German Psychoanalytical Association (DPV): Regaining the psychoanalytical orientation lost in the Third Reich. *International Journal of Psycho-Analysis*, 76, 945–956.
- Friedrich, Volker. (1988). Letters of an emigrant: The psychoanalyst Clara Happel to her son Peter, 1936–1945. *Revue internationale d'histoire de la psychanalyse*, 1, 323–348.
- Happel, Clara. (1923). Onanieersatzbildungen. *Internationale Zeitschrift für Psychoanalyse*, 9, 206–209.
- . (1927). Der Mann in der Kloake. *Zeitschrift für psychoanalytische Pädagogik*, 2, 86–89.
- . (1926). Communication: Notes on an analysis of a case of paederasty. *International Journal of Psycho-Analysis*, 7, 229–236.
- Steiner, Riccardo. (1989). It is a new kind of Diaspora. *International Review of Psychoanalysis*, 16, 35–72.

## **HARD SCIENCE AND PSYCHOANALYSIS**

“Hard sciences” are those disposing of a theory of measurement. The development of qualitative mathematics, since the middle of the 19th century, and its diverse applications have made this description questionable.

By the time he was thirty, Freud was a brilliant researcher in the field of natural science, well-versed in neuro-anatomy and neuro-physiology, in addition to having done some work in chemistry. At the laboratory of Brücke (1876–1882) he acquired an expertise in chemistry and physics, including thermodynamics (Helmholtz). As to epistemology, Freud, besides his familiarity with the German positivist school and the debates it carried on with Vienna (Brentano, Mach, Boltzmann), attended, for two years, Brentano's seminar on Aristotle.

In his writing, Freud refers little to the hard sciences as such. He uses the German system of classification: sciences of nature and of mind, situating psychoanalysis among the former, while insisting that it is relevant to “almost all the sciences of the mind” (1924f). There was one exception: “Strictly speaking, there are only two sciences: psychology, pure and applied, and natural science” (1933a, p. 179). Freud was frankly ironic about official sciences, assuming, moreover, the following position: “Scientific thinking does not differ in its nature from the normal activity of thought, which all of us, believers and unbelievers, employ in looking after our affairs in ordinary life” (1933a, p. 170).

The relationship between chemistry and psychoanalysis was formed early on—the former lent some of its prestige to the latter, signifying that the scientific method was common to both of them Freud, and Freud hoped that chemistry would isolate the toxins linked to sexuality and neuroses. The contribution of thermodynamics to his dynamic and economic point of view was evident also; his use of the terms “free energy” and “bound energy” makes this clear. Considerations of stability, carried over from Fechner, equally played a part. At a time when psychoanalysis was still unsure of its foundation, Freud defended the theory of the drives by noting that physics also was unsure of its foundations. Accordingly, he placed the discoveries of Copernicus and Darwin, and his own, on the same plane, for having dealt blows to human narcissism and religious convictions. Finally, a nostalgia for energetics surfaced when he evoked the “quantitative factor,” decisive for symptomatology, yet unattainable.

“Analysts ... cannot repudiate their descent from exact science and their community with its representatives. ... Instead of waiting for the moment when they will be able to escape from the constraint of the

familiar laws of physics and chemistry, they hope for the emergence of more extensive and deeper-reaching natural laws, to which they are ready to submit” (1941d [1921], p. 178–79). Qualitative dynamics, which reinterprets thermodynamics, may prove to be a part of this hoped-for emergence.

MICHÈLE PORTE

*See also:* Science and psychoanalysis.

### **Bibliography**

- Freud, Sigmund. (1924f). A short account of psychoanalysis. *SE*, 19: 189–209.
- . (1933a [1932]). New introductory lectures on psycho-analysis. *SE*, 22: 1–182.
- . (1941d [1921]). Psycho-analysis and telepathy. *SE*, 18: 173–193.
- Lacan, Jacques. (2002). *Écrits: A selection* (Bruce Fink, Trans.). New York: W.W. Norton.

### **Further Reading**

- Bucci, Wilma. (1997). *Psychoanalysis and cognitive science. A multiple code theory*. New York: Guilford Press.
- Holt, Robert. (1997). *Psychoanalysis and the philosophy of science*. Madison, CT: International Universities Press.
- Shevrin, Howard. (1995). Psychoanalysis: one science, two sciences, or no science?. *Journal of the American Psychoanalytic Association*, 43, 963–985.
- Strenger, Carlo. (1991). *Between hermeneutics and science. An essay on the epistemology of psychoanalysis*. Madison, CT: International Universities Press.

## **HARTMANN, HEINZ (1894–1970)**

Physician and psychoanalyst Heinz Hartmann was born in Vienna on November 4, 1894, and died in Stony Point, NY, on May 17, 1970.

Hartmann’s family had been distinguished for several generations. One grandfather, Moritz Hartmann, was a well-known poet, essayist, professor, and member of parliament; the other grandfather, Rudolf Chrobak, was an eminent physician and professor. Hartmann’s father, Ludo Hartmann, was a professor of history and founder of public libraries and adult education; his mother, Grete Chrobak, was a successful sculptor and pianist.

Tutors educated Hartmann until age thirteen; he continued in public schools and at the University of Vienna, where he attended lectures in many fields, earned his medical degree, and became a psychiatrist and faculty member in Wagner-Jauregg’s clinic. He published two papers on quinine metabolism during medical school, and then published several papers on psychiatry with Paul Schilder. Becoming interested in Freud, he published, with S. Betlheim, what became a minor classic paper in experimental psychoanalysis, “On Parapraxes in Korsakov Psychosis,” demonstrating by experiment the validity of some of Freud’s concepts of symbolization.

When Karl Abraham, with whom Hartmann had arranged to have a training analysis in Berlin, unexpectedly died, Hartmann had his first analysis with Sándor Rado; and while in Berlin wrote *Die Grundlagen der Psychoanalyse* (The foundations of psychoanalysis; 1927). Before 1937, he published about two dozen papers, including twin studies and studies of psychoses, neuroses, values, and cocaine; and he contributed to a major handbook on medical psychology. When Adolf Meyer offered Hartmann a full professorship at Johns Hopkins, Freud offered to analyze Hartmann free of charge if he would stay in Vienna. Hartmann was analyzed by Freud, and became a key member of his generation of Freud’s followers at the Vienna Psychoanalytic Society (a group including Helene and Felix Deutsche, Edward Bibring, Ernst Kris, Robert Waelder, Willy Hoffers, Hans Lampl, and Anna Freud), and co-editor of *The International of Journal of Psychoanalysis*. He married Dora Karplus, a pediatrician who later became a child and adult psychoanalyst. They had two sons, Ernest Hartmann and Lawrence Hartmann; one became a psychoanalyst and sleep and dream researcher, the other a child and adult psychiatrist, educator, and President of the American Psychiatric Association.

In 1937, Hartmann read to the Vienna Society a paper on ego psychology that developed into a book, *Ich-Psychologie und Anpassungsproblem* (1939) (later published in English as *Ego Psychology and the Problem of Adaptation*; 1958). Along with Anna Freud’s *The Ego and Mechanisms of Defense*, that work was a decisive landmark in extending psychoanalysis into the ego-psychological areas that would be central for the next several decades. In 1938, after the annexation of Austria by Nazi Germany, the Hartmanns moved to Paris, then to Switzerland, and in 1941 to New York.

There Hartmann became a leader of the New York Psychoanalytic Society and Institute, which was energized by many illustrious immigrants. He served for many years as a training analyst and as the first director of the Institute clinic. His old close friendship with Ernst Kris developed into many years of extraordinary collaboration, and they soon invited Rudolph Loewenstein to join them. Meeting once a year for many years, the three jointly wrote a series of major papers. With Kris and, in London, Anna Freud, Hartmann founded an annual, *The Psychoanalytic Study of the Child*, in 1945; he helped to establish and maintain it as one of the key publications in psychoanalysis for several decades. President of the International Psychoanalytic association in the 1950s, he was then elected their Honorary President for Life, and served as something of a dean of world psychoanalysis in the mid-twentieth century.

Hartmann was considered a major clinical analyst, teacher, theoretician, and metapsychologist, building on and extending Freud's ideas and findings. He was frequently an integrator. A pillar of that era's psychoanalytic establishment but not a cloistered thinker, he welcomed biopsychosocial thinking, contributions from general biology, neurobiology, and medicine; and also psychology, developmental theory, history, philosophy, anthropology, sociology, ethology, mythology, and art. He saw psychoanalysis as central to a general psychology.

Hartmann is best known for his work on ego psychology and adaptation, elaboration of conflict and drive theory, neutralization of aggression, and the conflict-free ego sphere, which serve as structures for much clinical and research work. Familiar analytic concepts such as structural and developmental theory, drive, and conflict were, by Hartmann's time, securely enough established to allow powerful additions, such as contributions from biology and interactions with average expectable (and other) environments, and such as ego functions and adaptation. His success in including mind-brain interactions, as well as centrally defining structures of mind-mind and mind-environment interactions, established some lasting solid ground, and also helped prepare the field for some subsequent analytic schools, notably object relations theory, self psychology, and continuing psychoanalytic attempts at biopsychosocial integration.

LAWRENCE HARTMANN

*Work discussed:* *Ego Psychology and the Problem of Adaptation*.

*Notions developed:* Ego autonomy; Ego, damage inflicted on the; Ego functions; Self.

*See also:* Adaptation; Alteration of the ego; Defense mechanisms; Desexualization; Ego; Ego (ego psychology); Ego libido/object libido; Ego psychology; France; Identification; Kris, Ernst; Lehrinstitut der Wiener Psychoanalytischen Vereinigung; Loewenstein, Rudolf M.; Neutrality/benevolent neutrality; New York Psychoanalytic Institute; *Psychoanalytic Study of the Child*, *The*; Self psychology; Self-representation; Société psychanalytique de Paris and Institut de psychanalyse de Paris; Stage (or phase); Structural theories; United States; Wiener psychoanalytische Vereinigung.

### Bibliography

Hartmann, Heinz. (1927). *Die Grundlagen der Psychoanalyse*. Leipzig: G. Thieme.

———. (1939). *Ego Psychology and the Problem of Adaptation*. New York, International Universities Press, 1958, 122 p.

———. (1944). The psychiatric work of Paul Schilder. *Psychoanalytic Review*, 31, (1), p. 296.

———. (1950). Comments on the psychoanalytic theory of the ego. *Psychoanalytic Study of the Child*, 7, 9–30.

———. (1956). The ego concept in Freud's work. *International Journal of Psycho-Analysis*, 37, 433.

(1964). *Essays on ego psychology*. New York, International Universities Press. (Original work published 1939)

Hartmann, Heinz; Kris, Ernst; and Loewenstein, Rudolf M. (1946). Comments on the formation of psychic structure. *Psychoanalytic Study of the Child*, 2, p. 11–38.

———. (1964). *Papers on psychoanalytic psychology*, New York: International Universities Press.

Hartmann, Lawrence. (1994). Heinz Hartmann: A memorial tribute and filial memoir. *Psychoanalytic Study of the Child*, 49, 3–11.

---

## HATRED

In day-to-day use, hatred is a violent feeling that impels the subject to wish another person ill and to take pleasure in bad things that happen to that person.

In "Instincts and Their Vicissitudes" (1915c), Sigmund Freud wrote that the primal structure of hatred reflects the relationship to the external world

that is the source of stimuli: “At the very beginning, it seems, the external world, objects, and what is hated are identical” (p. 136). The determining factor is thus the relationship to unpleasure. Freud thus asserted that “Hate, as a relation to objects, is older than love” (p. 139), for this feeling originates in the ego’s self-preservation instincts rather than in the sexual instincts (although later on hatred can bind with the latter to become “sadism”). It can be inferred from this that “hatred is a kind of self-preservation, to the extent of destroying the other, while loving is a way . . . of making the other exist,” as Paul-Laurent Assoun expressed it in *Portrait métapsychologique de la haine: Du symptôme au lien social* (Metapsychological portrait of hatred: from symptom to the social bond; 1995).

This emotion that aims to destroy thus seems to be radically opposite to love. But as Roger Dorey underscored in “L’amour au travers de la haine” (Love through hatred; 1986), there are deep affinities between the two: Not only does hatred precede love, but no doubt there is love only because there is hatred, at the very origin of the person” Indeed, in both “Instincts and Their Vicissitudes” and “Negation” (1925h) Freud showed that hatred is not exclusively destructive toward the object: Acting as the first differentiating boundary between inside and outside, it ensures the permanence of that boundary and is its constituting principle. Speaking of the purified pleasure-ego, which places the characteristic of pleasure above all others, Freud wrote in “Instincts and Their Vicissitudes” that love “is originally narcissistic, then passes over on to objects, which have been incorporated into the extended ego, and expresses the motor efforts of the ego towards these objects as sources of pleasure” (p. 138).

But prior to the establishment of genital organization, in which love has “become the opposite of hate” (p. 139), the two earliest stages make no distinction between them. The oral stage involves incorporating and devouring the object; in the anal-sadistic stage, “the striving toward the object appears in the form of an urge for mastery, in which injury or annihilation of the object is a matter of indifference” (p. 139). It must be recalled that hatred always expresses the ego’s self-preservation instincts and that both the will to power and the urge for mastery originate in hatred; before the genital stage, self-preservation of the ego is precisely what is endangered by the encounter with the object. The love/hate distinction that forms in the

genital stage allows them to be linked together, bringing whole persons into being.

If hatred is experienced as the unpleasure derived from the encounter with the “other” that threatens the ego’s integrity, the manner of being of this “other” must be reintroduced. With notions involving the determining role, for the baby, of the object, with its expected function as “container” of excitations, “toilet breast,” or alpha function, Donald Winnicott, Donald Meltzer, and Wilfred Bion, among others, have shed new light on the treatment of hatred.

NICOLE JEAMMET

*See also:* Aggressiveness/aggression; Aimée, case of; Ambivalence; Breast, good/bad object; Dead mother complex; Drive/instinct; *Ego and the Id, The*; Emotion; Erotomania; Frustration; “Instincts and their Vicissitudes”; Love-Hate-Knowledge (L/H/K links); Melancholia; Need for punishment; Negative therapeutic reaction; Negative transference; Object; Object, choice of/change of; Obsessional neurosis; Paranoia; Paranoid position; Persecution; Primary object; Projection; Racism, anti-Semitism, and psychoanalysis; Reversal into the opposite; Rivalry; Self-hatred; Self-mutilation in children; Shame; Splitting of the object; Superego; Transference hatred; Turning around; “Why War?”.

### Bibliography

- Assoun, Paul-Laurent. (1995). *Portrait métapsychologique de la haine: Du symptôme au lien social*. Paris: Anthropos.
- Dorey, Roger. (1986). L’amour au travers de la haine. *Nouvelle Revue de psychanalyse*, 33, 75–94.
- Freud, Sigmund. (1915c). Instincts and their vicissitudes. *SE*, 14: 109–140.
- . (1925h). Negation. *SE*, 19: 233–239.
- Jeammet, Nicole. (1989). *La Haine nécessaire*. Paris: Presses Universitaires de France.

---

### HEIMANN, PAULA (1899–1982)

Paula Heimann, British physician, psychiatrist, and psychoanalyst, was born Paula Glatzko on February 3, 1899, in Danzig, Germany, and died October 22, 1982, in London.

Heimann grew up in Danzig. She attended the High School for Girls and studied Medicine in Königsberg,

Berlin, Frankfurt am Main, and Breslau. She passed the “Staatsexamen” in 1925.

After attaining her MD, Heimann studied at the Psychiatric University Clinic in Heidelberg, and the Charité in Berlin. She received psychoanalytic training at the Berlin Psycho-Analytic Institute (1928–1932). Her training analyst was Theodor Reik. Other teachers included Otto Fenichel, Hanns Sachs, Franz Alexander, Karen Horney and Sándor Rado. She emigrated to London in 1933, and that year became an associate member of the British Psycho-Analytical Society. Heimann became a full member in 1939, a control supervisor in 1940, and a training analyst in 1944. In 1938, she received her British medical qualification from Edinburgh. She became a Fellow of the Royal College of Psychiatrists in 1971. In 1924, Heimann married Franz-Anton Heimann; they had one daughter and divorced in 1933.

In London Heimann became a close collaborator of Melanie Klein and in 1935 went into further analysis with her. The termination date is not known. In 1955 she left the Kleinian Group of Analysts of the British Psycho-Analytical Society. After years of increasing alienation on both sides, and she became an active member of the Independent Group of Psycho-Analysts. In 1949 she was elected a member of the Training Committee of the British Psycho-Analytical Society, becoming its training secretary in 1954.

She was an esteemed teacher and a sought-after training analyst and supervisor, at first for students of the Kleinian Group and later for those of the Independent Group. After the war she helped to train German analysts and went regularly on weekends to the Psychosomatic Clinic in Heidelberg and later to the Sigmund Freud Institute in Frankfurt am Main. Psychoanalytic institutes in France, Germany, Italy, North and South America invited her to give papers and hold seminars.

Paula Heimann wrote thirty papers. Her earlier contributions are of a Kleinian theoretical orientation, and two of them are contributions to the Controversial Discussions (1942–1944) of the British Psycho-Analytical Society. Her later papers mainly discuss various clinical problems and questions of technique, in particular those of transference, counter-transference, the psychoanalytic setting and different aspects of formulating and making interpretations.

She read her paper on “Counter-Transference” (1950) at the 16th International Congress of Psycho-Analysis in 1949, in which she conceived of the phenomenon as an important tool for the understanding of patients’ communications. The paper was influential for many other authors during the 1950s and 1960s. She never wrote a comprehensive critique of Kleinian theory and technique but it is often implicit in her later papers (1955–1982). She discussed the concept of sublimation and the concept of the death instinct in their clinical relevance in early papers (1942, 1952) from a Kleinian viewpoint, but presented a revision of them in later papers (1959, 1964). Her published contributions to discussions of papers read at International Congress of Psycho-Analysis (1962, 1964, 1966, 1970) are clear critical evaluations of the main papers presented.

MARGRET TONNESMANN

*See also:* Change; Controversial Discussions; Counter-transference; Dependence; Empathy; Great Britain; Paranoid position.

### Bibliography

- Heimann, Paula. (1950). On counter-transference. *International Journal of Psycho-Analysis*, 31, 81–84.
- . (1952). Certain functions of introjection and projection in early infancy. In Klein, Heimann, Isaacs, and Riviere (Eds.) *Developments in Psycho-Analysis* (p. 122–168). London, Hogarth.
- . (1962). Contribution to the discussion of “The curative factors in psycho-analysis”. *International Journal of Psycho-Analysis*, 43, p. 228–231.
- . (1989). *About children and children-no-longer. Collected papers of Paula Heimann 1942–1980*. M. Tonnesmann, London/New York: Tavistock Publications/Routledge.
- King, Pearl H.M., and Steiner, Riccardo. (1991). *The Freud-Klein controversies 1941–1945*. London/New York: Tavistock Publications/Routledge.

### HELD, RENÉ (1897–1992)

René Held, a French psychiatrist and psychoanalyst, was born October 7, 1897, in Paris, where he died on February 18, 1992. He was the second son of a family that had emigrated from Russia after a short stay in Germany. His father was unable to obtain an equivalency diploma for his medical degree and held a series

of relatively minor positions with pharmaceutical companies. Consequently, Held was forced to go to considerable efforts to become fully integrated in French society.

A man with curious mind, cultivated and sharp witted, Held was not immediately attracted to psychoanalysis. He was initially interested in psychiatry, which he had discovered during his medical studies at the Salpêtrière and then at Val-de-Grace during the First World War. It was here that he met André Breton and Louis Aragon. His was an inquisitive mind, and it was difficult for Held to settle into a sedentary and unchanging activity. The uncertainties of life led him to dabble in Russian revolutionary activities while he was an assistant surgeon in Kiev in 1917 (which earned him the Croix de Guerre in 1918). Through his friendship with the painters of the Paris School and his familiarity with the surrealist movement, he developed an in-depth understanding of art.

It is said that the young twenty-nine-year-old psychiatrist was offered an opportunity to participate in the foundation of the Société Psychanalytique de Paris (Paris Psychoanalytic Society) in November 1926 and that he refused—something he regretted all his life. The story is not entirely credible, however, as Held would have been more attracted to the newly formed *Évolution Psychiatrique*, because he was a contributor to the first issue of that organization's review.

During the 1930s, he was much more interested in developing a clientele as an independent psychiatrist than in adopting Freudian theories that were not yet fully accepted. He got married on March 26, 1926, had a son, Jean Francis, in 1930, and had divorced by 1933. His mother, who followed Jewish family tradition closely, almost never left his side from then on.

Miraculously, he managed to survive the Occupation unscathed. A disciplined Frenchman who believed in his country, Held registered as a Jew with the police in his area and returned home with a yellow star, which he decided, two days later, never to wear again. After narrowly escaping a roundup of French Jews, he left the city for the unoccupied countryside but returned to Paris, where, in spite of the seals that had been placed on the door of his apartment on avenue Raymond-Poincaré, he managed to live there, treating American pilots who had been hidden by the Resistance.

It wasn't until the Liberation that Held's name began to appear on the rolls of psychoanalytic meetings. He underwent a teaching analysis with John Leuba, and was then supervised by Sacha Nacht. At a meeting of the Société Psychanalytique de Paris held in October 1947, presided over by his analyst, he gave a talk on "a phobia about knives." It was here that he met Pierre Mâle, a man who was to remain a colleague and friend until his death. That same year he was made a member of the society. The following year, Professor Gilbert-Dreyfus created for him, at the La Pitié hospital, the first department of psychosomatic medicine.

He was not fond of Jacques Lacan and remained faithful to his friends during the 1953 split. He was made a full member of the Société Psychanalytique de Paris on February 16, 1954, when Pierre Mâle was president, and was given responsibility for teaching activities in the new Paris Psychoanalytic Institute. He taught psychosomatic medicine in 1954, and psychoanalytic psychotherapy, with Mâle, in 1957. In 1963, during the 24th Congrès des psychanalystes de langue française des pays romans (Congress of French-speaking psychoanalysts from Romance-language-speaking countries), he presented a "Rapport clinique sur les psychothérapies d'inspiration psychanalytique freudienne," which became a book, *Psychothérapie et Psychanalyse* (1968). He was also president of *Évolution Psychiatrique* and the Société de Médecine Psychosomatique (Society of Psychosomatic Medicine).

Held was a brilliant improviser, simultaneously droll and wise, sometimes carried away by his garrulousness. All of his verbal eloquence has vanished but, as Gérard Mendel, one of his analysts, wrote, "We have his books, four books, in which, regardless of the subject, the man could be seen on the page, thumbing his nose at dogma and obfuscation." His books include *De la psychanalyse à la médecine psychosomatique* (1968) and his memoir of surrealism published in 1973 as *L'Oeil du psychanalyste* (Payot). His last completed book—Held began dozens of unfinished projects for novels, scripts, and other writings—brings his critical faculties to bear on the then-current fashion for all things Freudian: *Problèmes de la cure psychanalytique d'aujourd'hui. Us et abus de la psychanalyse* (1976).

Although there was much that was colorful about Held's character, we must not overlook the originality of his ideas and his numerous contributions to the

psychoanalytic conferences organized by the SPP until the 1970s. As Roland Jaccard remarked, “rationalist, atheist, and materialist, René Held was an old-fashioned psychoanalyst: sensitive and warm, he placed the interests of his patients above those of theory.”

ALAIN DE MIJOLLA

*See also:* Face-to-face situation; France; Psychotherapy; Société psychanalytique de Paris and Institut de psychanalyse de Paris.

### **Bibliography**

Held, René. (1968). *De la psychanalyse à la médecine psychosomatique*. Paris: Payot.

———. (1968). *Psychothérapie et psychanalyse*. Paris: Payot.

———. (1973). *L'Œil du psychanalyste*. Paris: Payot.

Jaccard, Roland. (1992). La disparition de René Held: la psychanalyse et l'humour. *Le Monde*, Tuesday, February 25, 1992.

Mendel, Gérard. (1992). René Held toujours vivant. *Raison présente*, 102, 120.

---

## **HELLER, HUGO (1870–1923)**

Hugo Heller, the second Viennese publisher of Freud's works, was born in Hungary in 1870 and died in Vienna on November 29, 1923.

When he finished his secondary education, he trained as a bookseller and contributed to founding the “first populist bookshop in Vienna.” In 1905, he founded his own bookshop (Hugo Heller & Co.) comprising a publishing house, an art gallery, and a reception hall. Many exhibitions and conferences were organized in this richly endowed bookshop by contemporary poets and artists such as Arnold Schönberg, Rainer Maria Rilke, Hugo von Hofmannsthal, Jakob Wassermann, and Thomas and Heinrich Mann. In response to the cultural orientation of this bookshop, its clients came from the intellectual elite of Vienna.

Freud was one of the regular customers and in 1907 he gave a conference, “Der Dichter und das Phantasieren” (Creative Writers and Day-Dreaming, 1908e), to Heller's literary-minded public. Relations between Hugo Heller and Freud were not based solely on Freud's interest in literature; they were also consolidated by

Heller's interest in psychoanalysis. He was of the small circle of the founding members of the Wednesday Society, where he delivered his first paper: “Zur Geschichte des Teufels” (On the History of the Devil). Even before Lou Andréas Salomé was invited to attend the Wednesday Society, Heller had already given them an account of the work of this author who was already enshrined in the mists of legend. His daughter, Maggie Heller, was one of the pioneers of psychoanalytic teaching. In 1906 she organized a survey of writers and scientists, asking them to list “ten good books.” Arthur Schnitzler, Ernst Mach, and Peter Altenberg, along with Freud and others, responded to the survey, which Heller published under the title *Vom Lesen und von guten Büchern* (Reading and good books).

During World War I, Heller took over the scientific section of the Deuticke publishing house and became the “real publisher of the house of Freud.” For Heller this change in Deuticke also reflected the new interest of psychoanalysis in terms of its applications for the mind sciences and the broadening of its readership toward a more general public. In the literary, but also the social democratic context of this publishing house the following works of Freud were published: *Delusions and Dreams in Jensen's “Gradiva”* (1907a), *Totem and Taboo* (1912–13a), the “Collection of short writings on the theory of the neurosis” (4 volumes, 1907–09) and *Introductory Lectures on Psychoanalysis* (1916–17a). Its catalog of authors also included analysts like Otto Rank and Alfred von Winterstein.

Hugo Heller also took the risk of publishing two psychoanalytic reviews, the *Internationale Zeitschrift für (ärztliche) Psychoanalyse* and *Imago*, after several other publishers had backed down. Theodor Reik, who was working in Heller's bookshop at the time, took charge of the two reviews. During the war the publishing house suffered from production conditions that went from bad to worse, with the result that it became problematic to produce the two reviews. Finally, Heller publications could no longer ensure a regular production of books. As a result, Freud's work *Zur Vorbereitung einer Metapsychologie* (Toward the Preparation of a Metapsychology), which he had entrusted to Heller, never went to print and is considered to have been lost.

After the creation of the Internationaler Psychoanalytischer Verlag in 1919, Heller handled only the distribution of periodicals and books. After World War I, although still a member of the Viennese Psychoanalytic

Association, he no longer attended their meetings. When he died on November 29, 1923, an obituary in the *Internationale Zeitschrift für Psychoanalyse* observed that Viennese Psychoanalytic Society had lost one of its oldest members.

LYDIA MARINELLI

See also: Deuticke, Franz; *Imago. Zeitschrift für die Anwendung der Psychoanalyse auf die Geisteswissenschaften*; *Internationale Zeitschrift für (ärztliche) Psychoanalyse*.

### Bibliography

Hall, Murray G. (1985). *Österreichische Verlagsgeschichte 1918–1938*. Vienna-Köln-Graz.

Mühlleitner, Elke. (1992). *Biographisches Lexikon der Psychoanalyse (Die Mitgleider der Psychologischen Mittwoch-Gesellschaft und der Wiener Psychoanalytischen Vereinigung 1902–1938)*. Tübingen: Diskord.

Nunberg, Herman, and Federn, Ernst. (1962–78). *Minutes of the Vienna Psychoanalytic Society*. New York: International Universities Press.

Worbs, Michael. (1983). *Nervenkunst. Literatur und Psychoanalyse im Wien der Jahrhundertwende*. Frankfurt-am-Main.

## HELLMAN NOACH, ILSE (1908–1998)

Dr. Ilse Hellman Noach, distinguished psychoanalyst and expert on child development, was born in Vienna on September 28, 1908, and died in London on December 3, 1998. Her parents, Paul and Irene Hellman, were deeply engaged in the cultural climate of the day, encouraging the arts and promoting the talents of musicians who achieved distinction.

Fascinated by children, Hellman, on leaving school, completed a two-year course specializing in juvenile delinquency. She joined a home near Paris for the children of parents unable to care for them, and her fluent French allowed her to attend evening classes in psychology at the Sorbonne. The home was run on family lines, and the same staff member looked after each small group of children. On returning to Vienna, she attended the University and studied under Charlotte Buhler, Professor of Child Development, who was making detailed studies of children from birth onwards. Buhler was invited to London as visiting Professor at University College, retaining her post in

Vienna, and in 1937 she invited Hellman, who by then had been awarded her Ph.D., to join her in the study of retarded children. When Buhler was in Vienna, Hellman took charge. It was then, too, that she met the distinguished analyst and child expert, Susan Isaacs, who became a close friend.

At the outbreak of war Buhler left for the United States, and the Home Office employed Ilse Hellman and other psychologists to work with children evacuated from London to escape the threat of air raids. Taken from their mothers to remote areas, many suffered disturbed sleep, eating disorders and bedwetting, and the psychologists set up special homes to cope with these problems. In 1942, Freud's daughter Anna invited Hellman to join her war nurseries, set up to provide for children whose families were disrupted by wartime bombing, and she remained there until the nurseries closed at the end of the war. The staff was residential and, to facilitate attachment to a substitute parent, each member cared for the same small group of children (as in the French home). The three homes together cared for 150 children, and the staff slept wherever they could. The children's development was rigorously observed and meticulously recorded, and Ilse Hellman found the experience invaluable for the understanding of the effects of separation, the restriction of the damage it occasioned, and child observational research. She continued to meet with, and evaluate, her own "war babies" for over fifty years.

While at the nurseries, she trained in psychoanalysis, and rapidly rose to prominence in the British Psycho-Analytical Society. Her attractive and friendly personality put her on the best of terms with Melanie Klein, Donald Winnicott and other well-known analysts: theoretical differences never interfered with friendship. She joined the Staff at Anna Freud and Dorothy Burlingham's Hampstead Child Therapy Course and Clinic, which had quickly earned a worldwide reputation. The clinic originated major studies on child development, normative and pathological, to many of which Ilse contributed. For some years she was in charge of the department for adolescents, publishing valuable papers about the difficulties encountered with this age group. She wrote on many other subjects. She was a fine teacher. Her deeply empathic understanding of the problems encountered by students in their clinical work made her a valued mentor in work with both adults and children. Her clinical



skills with children of all ages secured her international reputation.

It was not until after the war that she learned that her mother and brother had died in Nazi concentration camps. It was then she met and married the art historian, Arnold Noach, who had survived the Nazi occupation of Holland. He later became Professor of the History of Art at the University of Leeds. His was a fun-loving and warm personality. He died suddenly in 1976. Hellman Noach continued her work for many years, although in the last few years she worked much less intensively. Impressed by the fact that many young people showed great trust, and a readiness to confide in her, she amusingly called herself an “analytic grandmother.” But, at the age of 84, increasing ill health forced her to abandon the practice of, though not the interest in, the profession she had served so well.

She endured a cruelly incapacitating illness with great fortitude, always finding a warm and welcoming word for her visitors. Generations of analysts have cause to be grateful for her guidance, instruction, and, above all, her wisdom. She was survived by her one daughter, Maggie, and grandchild, Sophie.

CLIFFORD YORKE

*See also:* Great Britain.

### **Bibliography**

Hellman, Ilse. (1990). *From war babies to grandmothers: Forty-eight years in psychoanalysis*. London: Karnac.

## **HELPLESSNESS**

The state of helplessness is linked to the infant’s initial powerlessness in the face of its needs. This causes distress, as the protective shield is overwhelmed; only the intervention of another person can relieve this suffering.

The neurophysiological model of Sigmund Freud’s “Project for a Scientific Psychology” (1950c [1895]) posits the baby’s original helplessness as the prototype of all traumatic situations. Helplessness and satisfaction structure the two modes of mental functioning. In the primary mode, the desired object and desired satisfaction are hallucinated immediately through recathexis of the memory traces left by the real experience. In the secondary mode, a lasting discharge forms

the basis for the relationship to the real object, lost and rediscovered thanks to “indications of reality,” and invested with the meaning “mutual understanding.”

Helplessness and the theory of anxiety are closely linked. The helpless baby, powerless to fulfill its needs and without any adequate means of discharging internal excitation, experiences “automatic anxiety.” Anticipation of helplessness triggers “signal anxiety,” the ego’s appeal to the ego (1926d [1925]).

In a state of helplessness owing to its prematurity, the preverbal human infant cries, experiences and recognizes its powerlessness, and urgently alerts the succoring object. The ability to apprehend its helplessness depends on the protective shield against stimuli, whose action is thus the basis of relationships, the precondition of effective communication.

For Melanie Klein (1952/1975), the distress associated with the death instinct, a source of tremendous persecution, precipitates projection. This is the foundation of what she calls the schizoid-paranoid position.

When a human being is reduced to a state of helplessness, subjected to a primal kind of passivity by the impositions of others, he or she may seek to regain mastery through repetition of the experience. For Kreisler et al. (1966), too much distress of this kind may cause psychosomatic disorders; for Tustin (1972), the result may be recourse to autistic defenses.

ANNE AUBERT-GODARD

*See also:* Alpha function; Anxiety; Dependence; Illusion; Narcissitic injury; Prematurity; Transference depression; Thing, the; Trauma.

### **Bibliography**

Freud, Sigmund. (1925). Inhibitions, symptoms and anxiety. *SE*, 20: 87–172.

———. (1950c [1895]). Project for a scientific psychology. *SE*, 1: 281–387.

Klein, Melanie. (1975). Some theoretical conclusions regarding the emotional life of infants. In *The writings of Melanie Klein* (Vol. 3, pp. 61–93). London: Hogarth Press. (Original work published 1952)

Kreisler, Léon, Fain, Michel, and Soulé, Michel. Études sur la clinique psychosomatique du premier âge. Coliques, insomnie, mérycisme, anorexie, vomissements. *Psychiatrie de l’enfant*, IX (1), 89–222.

Tustin, Frances. (1972). *Autism and childhood psychosis*. London: Hogarth.

## “HEREDITY AND THE AETIOLOGY OF THE NEUROSES”

Sigmund Freud first published this article in French in the *Revue neurologique* in Paris. It is important for two independent reasons. The first reason is historical, in that it contains the first occurrence of the word “psychoanalysis.” The second reason is more theoretical, in that the article makes a clear distinction between Freud’s theories and those deriving from Jean Martin Charcot’s teaching on the role of heredity in the etiology of the neuroses. The article goes on to provide a complete exposition of Freud’s thoughts on the sexual etiology of neuroses, and his theory of seduction.

The opening sentence reads: “I am addressing in particular the disciples of J.-M. Charcot, in order to put forward some objections to the aetiological theory of the neuroses which was handed on to us by our teacher” (1896a, 143). Heredity is only a “condition,” to borrow the term used in the distinction already made the year before (1895f), but it is the “specific causes” that must be sought.

Referring back to the nosographical distinctions he made between hysteria, obsessional neurosis, neurasthenia, and anxiety neurosis, he affirms that these “functional pathological modifications *have as their common source the subject’s sexual life, whether they lie in a disorder of his contemporary sexual life or in important events in his past life*” (p. 149). He adds: “I am quite sure that this theory will call up a storm of contradictions from contemporary physicians” (pp. 149–50).

The etiology of neurasthenia lies in immoderate onanism and spontaneous pollutions, and that of anxiety neuroses in forced abstinence, or genital irritation that does not result in orgasm. With regard to the other states: “I owe my results to a new method of psycho-analysis, Josef Breuer’s exploratory procedure; it is a little intricate, but it is irreplaceable, so fertile has it shown itself to be in throwing light upon the obscure paths of unconscious ideation” (p. 151). The origin of the disorders is a memory that is related to the sexual life: “The event of which the subject has retained an unconscious memory is a *precocious experience of sexual relations with actual excitement of the genitals, resulting from sexual abuse committed by another*

*person; and the period of life at which this fatal event takes place is earliest youth—the years up to the age of eight to ten, before the child has reached sexual maturity”* (p. 152). The memory of this act passively suffered in dread: “*The memory will operate as though it were a contemporary event. What happens is, as it were, a post-humous action by a sexual trauma*” (p. 154).

The precocious event can also be found in “obsessional neurosis,” but with a “capital” difference: “it is a question . . . of an event which has given *pleasure*, of an act of aggression inspired by desire (in the case of a boy) or of a participation in sexual relations accompanied by enjoyment (in the case of a little girl). The obsessional ideas . . . are nothing other than *reproaches addressed by the subject to himself on account of this anticipated sexual enjoyment*” (p. 155).

Sent to the *Neurologisches Zentralblatt* on the same day, February 5, 1896, the article *Further Remarks on the Neuro-Psychoses of Defence* reviews the last two etiologies and develops the notion of *repression*, which is missing from the French text. Freud also adds the analysis of a “case of chronic paranoia” that shows that this affection also comes “from the repression of distressing memories and that its symptoms are determined in their form by the content of what has been repressed” (1896b, pp. 174–75).

Of course Freud had sent these considerations to Wilhelm Fleiss a few months earlier, but they find their first public expression here. He made the following comment to Fleiss on April 26, 1896: “A lecture on the etiology of hysteria at the psychiatric society was given an icy reception by the asses and a strange evaluation by Krafft-Ebbing: ‘It sounds like a scientific fairy tale.’ And this, after one has demonstrated to them the solution of a more-than-thousand-year-old problem, a *caput Nili*. They can go to hell, euphemistically expressed” (1985c [1887-1904]).

The seduction theory has often been called into question in the course of the history of psychoanalysis, from Freud’s abandonment of his “neurotica” in September 1897. Taken up again by Sándor Ferenczi in 1932, then by his disciples, the theory has also seen polemical use, by Jeffrey Masson in 1984.

ALAIN DE MIJOLLA

See also: Choice of neurosis; Constitution; France; Memories; Obsession; Reminiscence.

**Source Citation**

Freud, Sigmund. (1896a). L'hérédité et l'étiologie des névroses. *Revue neurologique*, 4: 161–169; *GW*, 1: 407–422; Heredity and the aetiology of the neuroses. *SE*, 3: 141–156.

**Bibliography**

Freud, Sigmund. (1895f). A reply to criticisms of my paper on anxiety neurosis. *SE*, 3: 118–139.

———. (1896b). Further remarks on the neuro-psychoses of defence. *SE*, 3: 157–185.

———. (1896c). The aetiology of hysteria. *SE*, 3: 186–221.

———. (1985c [1887–1904]). *The complete letters of Sigmund Freud to Wilhelm Fliess 1887–1904* (Jeffrey M. Masson, Ed. and Trans.). Cambridge, MA : Belknap/Harvard University Press.

Masson, Jeffrey Moussaieff. (1984). *The assault on truth*. New York: Farrar, Straus & Giroux.

**HEREDITY OF ACQUIRED CHARACTERS**

The expression “heredity of acquired characters” generally refers to the transmission to descendants of modifications taking place in the course of the individual life of a forebear, such transmission being possible by virtue of these modifications being integrated into the forebear’s genotype. Such modifications may be morphological, functional, or even behavioral (acquired through learning). This idea, which was central to the evolutionism of Jean-Baptiste Lamarck, was later very largely rejected. Freud nevertheless accorded it a non-negligible role in some of his theoretical views.

We have to bear in mind that psychiatry and psychology at the end of the nineteenth century were very strongly marked by the idea that individual characteristics were essentially determined by hereditary data (in the genetic sense), whether in reference to normal or pathological development, including mental pathologies. It must also be said that in this domain the theory of degeneration was well established.

It is not surprising that Freud initially stood by the theory. In 1888 he wrote, in agreement with Jean Martin Charcot, that “the aetiology of the *status hystericus* is to be entirely looked for in the heredity” (1888b). However, he made a clear distinction over the following years between the inherited “constitutional” causes that provide the individual’s base psychic terrain, and the “occasional causes,” principally the

vicissitudes of sexual life, which alone could explain the appearance and form of the mental pathology. Publishing his translation of Charcot’s *Leçons du mardi* (Tuesday lectures), he went so far as to contradict him by writing that “the most frequent cause of agoraphobia, as well as the other phobias, does not reside in heredity but in the anomalies of sexual life” (1892–94a).

In *Studies on Hysteria* (1895d) he actively criticized recourse to the notion of degeneration as an explanation of hysterical phenomena, and restated the complementary nature of constitutional and accidental causes. He never departed from this position, which he stated clearly in the manuscripts he addressed to Wilhelm Fliess (Ms B, 1950a), then repeated in his article in French on *Heredity and the Aetiology of the Neuroses* (1896a), and each time over the following years that he discussed the problem of the “choice of neurosis”—the determination of a subject’s evolution toward hysteria or phobia.

The problem took on a greater dimension when Freud undertook to answer the question that cannot fail to rise in such a perspective: where do the “constitutional causes” themselves come from? He answered with a thesis inspired by Charles Darwin, and even more so by Ernst Haeckel, that found its most complete formulation in *Totem and Taboo* (1912–13a): major events in the prehistory of humanity mark all its later development and fashion the individual development of each child. This recourse to “phylogenesis” was coupled with two postulates: the first borrowed from Lamarck (transmission of acquired characters), the second from Haeckel (ontogenesis recapitulates phylogenesis). He focused on the hereditary transmission of general developmental factors and psychic function, remaining more discreet on the subject of differential factors.

These Freudian theses have been vigorously criticized, particularly their Lamarckian aspect which seems to have been eliminated by the victory of neo-Darwinism and modern genetics. Contemporary work in molecular genetics and population genetics seems to suggest new ways of formulating the question of psychic heredity (Chiland C., Roubertoux P., 1975–1976).

ROGER PERRON

See also: Constitution; Cultural transmission; Identification fantasies; Instinct; Intergenerational; Phylogenesis;

*Phylogenetic Fantasy, A: Overview of the Transference Neuroses; Prehistory; Thalassa. A Theory of Genitality.*

### Bibliography

- Chiland, Colette, and Roubertoux, Pierre. (1975–1976). Freud et l'hérédité. *Bulletin de psychologie*, 4–7.
- Freud, Sigmund. (1888b). Hysteria. *SE*, 1: 39–60.
- . (1892–94a). Preface and footnotes to the translation of Charcot's "Tuesday Lectures." *SE*, 1: 129–144.
- . (1896a). Heredity and the aetiology of the neuroses. *SE*, 3: 141–156.
- . (1912–13a). Totem and Taboo. *SE*, 13: 1–161.
- . (1950a [1887–1902]). Extracts from the Fliess papers. *SE*, 1: 173–280.
- Freud, Sigmund, and Breuer, Josef. (1895d). Studies on hysteria. *SE*, 2: 48–106.

## HERMANN, IMRE (1889–1984)

Imre Hermann, Hungarian neurologist and psychoanalyst was born on November 13, 1889 in Budapest and died there on February 22, 1984.

He spent most of his long life in Budapest where he was born. He received his medical degree in 1913. While still a university student, he became interested in experimental psychology. During the 1918–19 revolutions he was assistant professor to Géza Révész at the faculty of psychology. There he met Alice Czinner, also Révész's student, who became an analyst herself and his life companion of fifty-three years (1922–1975).

He set up analytical practice in 1919. Discounting the few months of the siege of Budapest during the German occupation, he continued his psychoanalytical practice without interruption up to the last months of his life. While a university student, he also attended Sándor Ferenczi's lectures, and it was Ferenczi who invited Hermann to join the society. Hermann was a member of the Hungarian and International Psychoanalytical Societies from 1921; Secretary of the Hungarian Psychoanalytical Society from 1925, vice-president between 1936–44, and president between 1945–49. An honorary professor, he lectured at the medical university and the faculty of arts in Budapest between 1946–49.

His first important works were in the field of the psychology of thinking; *Psychoanalyse und Logik*

(1924), *Das Ich und das Denken* (1929). In the first he explored the unconscious background of certain logical steps, such as doubling and reversal, based on observations of patients. In the second, he established a relationship between individual differences in thought processes with sense-organ orientation. In a series of experiments in 1921, he demonstrated, that, given a choice of identical elements, a child will select an external element, while an adult will select a center element, but that in a regressive state external selection returns. Unconscious operations also tend toward external selection. His book, *Pszichoanalízis, mint módszer* (Psychoanalysis as a Method, 1933; published in German in 1934; 1963) is a summary of the results of his teaching of psychoanalysis.

In the 1920s his interest turned toward the behavior of primates. He noted a peculiar instinctive behavior of the offspring of anthropoid apes: they spend the first months of their lives clinging onto the fur of their mothers. He set forth his theory of the clinging instinct in detail in *Az ember ősi ösztönei* (The Primeval Instincts of Man; 1943, 1984). Hermann's interest also extended to a number of other areas. His monographs about Fechner (1925) and János Bólyai (1945) and several other writings show interest in the psychology of creativity. He also published the book, *Az antiszemizmus lélektana* (The Psychology of Anti-Semitism; 1945). Based on clinical observations of obsessional neurosis he identified the dissociated superego. He noted the relationship between affectivity and space perception. Toward the end of his life he found a relationship to exist between musicality and perversions.

Hermann's theory of the clinging instinct prepared the way for the work of John Bowlby and René Spitz, and supported Mihály Bálint's theory of primary object relationship. His studies in the psychology of thinking make him one of the forerunners of ego psychology. In addition, he deserves credit for maintaining the continuity of psychoanalysis in Hungary and for reintroducing psychoanalytic training during the period of liberalization of communist dictatorship.

HUNGARIAN GROUP

See Also: Alcoholism; *Christians and Jews: A Psychoanalytical Study*; Clinging instinct; Hungarian School; Hungary; Racism, anti-Semitism and psychoanalysis; Shame.

**Bibliography**

- Binet, Agnes. (1984). Útbaigazítás. In Hermann (Ed.): *Az ember ő si ösztönei* (pp. 15–33). Budapest: Magvető.
- Hermann, Imre. (1933). *A pszichoanalízis, mint módszer*. Budapest: Novák R. és Tsa.
- . (1943). *Az ember ő si ösztönei Pantheon*. Budapest: Magvető, 1984.
- Nemes, Lívia. (1984). Hermann Imre munkássága. In *Hermann Imre “Az ember ő si ösztönei”* (p. 586–612). Budapest: Magvető.
- Vikár, György. (1985). Obituary. Imre Hermann, 1889–1984. *International Journal of Psycho-Analysis*, 66, 111.

**HERMENEUTICS**

The term *hermeneutics* is used broadly to describe the process of justifying interpretation through exposing the criteria used to produce it. The form is also used, by extension, to designate a twentieth-century philosophy for which interpretation is either a condition for accessing meaning through thought, and therefore a condition of every science of mind as such, thus implicating the normativity of logic, or the *praxis* of thought itself, no product of thought being capable of escaping infinite reinterpretation since it would then no longer be living thought but dead thought.

In a limited sense, Logic, as understood by Aristotle's *Organon*, has been and remains the framework of hermeneutics. “*Hermeneia*,” Paul Ricoeur writes, “in the fullest sense, is the meaning of the sentence”—and goes on to criticize an “overly ‘lengthy’ concept” of interpretation. But this is also the case when “hermeneutics” is understood as biblical exegesis (an “overly restricted” sense). Here it is theology, understood as an exclusive theory and therefore as a preestablished doctrine, that conditions truth and falsehood, and thus access to the determination of meaning. It should not be surprising therefore to find within the result of the interpretation what we were trying to find from the start.

Understood as philosophy, hermeneutics rejects the fact that logical concepts, in the Hegelian sense, can present and determine meaning, or that the “logic of the concept” can be its concretization; nor can the concept serve as a criterion of signification. However, hermeneutic finality can remain with the concept in

the sense of discourse, or, on the contrary, an interpretation that falls short of the separation of words and things, an interpretation of the constitution of a possible world by each and for all, or even a fundamental process of “leveling” the language of the unconscious.

Freud considered that analytic interpretation, at the clinical situation, transmutes the patient's dreams into the true creative and critical power of subjectivity. For this reason interpretation is not and could not be an “extension” of the dream, as Ludwig Wittgenstein claimed, believing to have found in this a critique of the unscientific nature of Freudian “hermeneutics.” Since, according to Wittgenstein, to interpret a dream is to prolong it, Freud's method of dream interpretation remains within the dream from the point of view of its scientific value. Thus one can also say that hermeneutics risks arbitrariness or relevancy that is only superficial to the extent that it can drift into an imaginary free association of ideas in connection of symbiotic or “esoteric” object, whereas this free association must itself be the object of a rigorous interpretation with reorganized and shared criteria; so hermeneutics also runs the risks of falling into a “delirium of interpretation,” a psychotic hermeneutics used by the schizophrenic, who cultivates a discourse of paradoxes in order to protect himself from ambivalence and conflict (Paul-Claude Racamier).

DOMINIQUE AUFFRET

*See also:* Amplification (analytical psychology); Deferred action; Interpretation; Philosophy and psychoanalysis.

**Bibliography**

- Ricoeur, Paul. (1965). *History and truth*. (Charles A. Kelbley, Trans.). Evanston, IL: Northwestern University Press. (Original work published 1955)
- . (1970). *Freud and philosophy: An essay on interpretation*. (Denis Savage, Trans.). New Haven: Yale University Press. (Original work published 1965)
- . (1974). *The conflict of interpretations* (Don Ihde, Ed.). Evanston, IL: Northwestern University Press. (Original work published 1969)

**HEROIC IDENTIFICATION**

Didier Anzieu proposed the notion of heroic identification in connection with his concept of the group illusion (1971). Anzieu extensively studied group

dynamics and made significant contributions to that field with his ideas of the skin-ego (1984, 1989) and psychic envelopes.

By “group illusion,” he wrote, “I mean a particular mental state that is seen in natural groups as well as in therapeutic or formative groups, and that is spontaneously verbalized by group members in the following form: ‘We are doing well together; we’re a good group; our leader or our supervisor is a good leader, a good supervisor’” (1971). According to Anzieu, three conditions are necessary to establish the group illusion: the designation of one group member as a victim or scapegoat (“One of us is bad”), the formulation of an egalitarian theory (“We are all alike”), and finally, the refusal to take gender differences into account (“We are all born outside of sexual relations”). With regard to this last condition, he further explained, “The group illusion expresses an unconscious statement according to which group members are not born in the same way as individuals, but are instead a product of parthenogenesis, living within the body of a fertile and all-powerful mother” (1971).

With this set of conceptual tools, Anzieu reminded us that the group derives from a founding father, and as Freud showed in “Group psychology and the analysis of the ego” (1921c), the great majority of group members are, or believe themselves to be, equally loved by the founding hero. “For the founder, the group serves as a fantasized resonator that gives body to his ideas, and as a mediator for making these ideas known to a broad public. For the group members, the founder satisfies their heroic desires and proves that they can obtain the love of the superego” (Anzieu, 1984).

Such, then, are group members’ identifications with the heroism of the group’s founder and leader. As was often his practice, Anzieu drew examples from mythology to support this concept, which enriches and complements the classical Freudian views on identification.

BERNARD GOLSE

*See also:* Ego ideal/ideal ego; Group analysis; Identification.

### **Bibliography**

Anzieu, Didier. (1971). L’illusion groupale. *Nouvelle revue de psychanalyse*, 4, 73–93.

———. (1984). Les groupes et leurs romans des origines. In Didier Anzieu, Bertrand Cramer, Georges David, et al., *Le nouveau roman familial, ou “On te le dira quand tu seras plus grand”* (pp. 99–109). Paris: E.S.F.

———. (1989). *The skin ego* (Chris Turner, Trans.). New Haven, CT: Yale University Press. (Original work published 1985)

Freud, Sigmund. (1921c). Group psychology and the analysis of the ego. *SE*, 18: 65–143.

---

## **HEROIC SELF**

The heroic self, as understood by Riccardo Steiner (1999), refers to the creative person’s specific need to associate with, to compete with, and to surpass, the heroes of their own or of some other cultural tradition. Although the heroic self is principally a component specific to the creative personality, it is present, in varying degrees, in every single person.

Steiner’s notion of the “heroic self” is derived, through the work of Daniel Lagache, Hermann Numberg, Alain de Mijolla, André Green, Jacques Lacan, and other French authors, from the phenomenological differentiation of the various aspects of the ego as originally described by Freud in his paper entitled “On Narcissism: an Introduction” (1914c). In this work, Freud spoke of the existence of an “ideal ego” and of an “ego ideal,” and later he also mentioned the existence of a “superego.” The heroic self is one of the ways in which the ideal ego manifests itself. Forming part of the constitutional endowment of the creative personality, it has, of course, constitutional aspects. Yet, understood from a Kleinian point of view, the heroic self can either be fostered or inhibited, from the beginning of life, by the *reverie*, or by the lack of *reverie*, shown by the mother and the parental couple. Later on in life, it can also be fostered, or inhibited, by relatives, by teachers, by cultural or other institutions, depending on the attitude these have towards the potential heroic self of the creative personality.

The heroic self manifests itself through what Steiner calls heroic projective and introjective identifications. The way in which it manifests itself depends on the individual’s previous vicissitudes. If, for instance, the heroic self has been properly fostered by the creative person’s family, or by their educational environment (by a teacher, school, etc.), at a certain moment the creator will start to feel the specific need to identify parts of the self with the heroes of their own or of

some other cultural tradition. They will do this via heroic projective identifications, as they will also be able to introject those same heroes via introjective identification. Particularly interesting, developmentally speaking, is the period Freud called “the family romance,” and during adolescence, when it is often possible to observe the first manifestations of the heroic self, although Steiner insists that the unconscious roots of the heroic self have to be traced back to the earliest object relationships and to the way they have been dealt with during the depressive position phase.

Conceived in this way, the heroic self constitutes an important aspect of the creative process. Due to the creator’s constant interaction with its chosen tradition or peers, the creative process can never therefore be conceived to be developing in a socio-cultural vacuum, nor can it ever be understood as being a purely subjective process. In other words, there can never be a relationship between the creator and their unconscious which excludes all relationship with the tradition or the peers of the creator’s heroic self.

For various psychopathological reasons, and as a result of events experienced during the course of infantile and adolescent development, the heroic self and its heroic introjective and projective identifications can be deeply disturbed and, in some cases, can almost cease to exist. All this can result in a megalomaniac distortion of the heroic self, which comes to feel narcissistically and destructively superior to any form of dependence on peers or cultural traditions. In such cases, creators isolate themselves and refuse to learn from peer or cultural traditions. The disturbances can also manifest themselves as a profoundly paralyzing and melancholic “apathic” which again leads to impossibility of the individual being able to relate constructively to peers or cultural traditions, or to be able to learn from them.

In order for the creative personality to be able to use their own heroic self and their heroic projective and introjective identifications, it is vitally important that help is given to the damaged creative personality, via psychoanalytic treatment, to repair not only their own internal and external objects, but their heroic self as well. This leads to it being possible for the creative personality to learn from their heroic peers, or from the heroes of the chosen tradition. And, in the case of genuinely creative personality, it leads to a capacity to tolerate the specific anxiety related to the need not

only to bypass their biological parents and their creativity, but also to bypass and to compete constructively with the great heroes of their cultural tradition, and, sometimes, with great heroic peers. Particularly important is the possibility for the creator’s heroic self to be able to identify with the creative intercourse of their parents, at least in fantasy. This does not necessarily mean that the creator has to generate children! Very often, their “children” are their creative results. All this is possible, according to Steiner, if the creator and their heroic self have achieved a good enough, even if not absolute, capacity to function according to what Klein and her followers have called the depressive position (Segal, 1991).

The notion of the “heroic self” and its heroic projective and introjective identifications may help one to acquire a better understanding of certain general aspects of the creative process, particularly those concerning the creator’s relationship with the cultural tradition or traditions to which they belong, or of which they make use in their own work. It can therefore lead to a better psychoanalytic understanding of cultural movements such as classicism, romanticism, futurism, and the like, because these all involve a particular unconscious and emotional relationship between creativity, individuality, originality, and the role played in it by tradition. It can also shed light on the way it is possible, from a psychoanalytic point of view, to evaluate a creative work in general. Even the reader, the literary or art critic, and so on, all have to mobilize their heroic selves and their heroic projective and introjective identifications in order to understand and evaluate a creative work.

If one looks at its psychopathological manifestations, the notions of a megalomaniac psychopathic heroic self (and this is something Daniel Lagache has pointed out at an individual level) can help to clarify some aspects of what could be called a “folie à plus,” which is to say a stimulation of the megalomaniac and psychopathic aspects of the heroic self at a mass level. In order to do this, the mass needs a megalomaniac and psychopathic leader. All this could help towards a better understanding of the unconscious roots of the power which appeals to groups and to the masses, based on their reference to the “heroes,” past or present, of a particular cultural or historical tradition, not least certain past and present-day religious figures and movements. These heroes, religious figures and movements have been used, and continue to be used, in a

distorted and destructive way by both old and more recent totalitarian and fundamentalist regimes.

RICCARDO STEINER

*See also:* Creativity; Ego ideal; Ego ideal/ideal ego; Grandiose self; Heroic identification; Myth of the hero; Self; *Trauma of Birth, The*.

### Bibliography

Lagache, Daniel. (1982). La psychanalyse et la structure de la personnalité. In his *Oeuvres* (pp. 163–78). Paris: Presses Universitaires de France. (Original work published 1962)

Segal, Hanna. (1991). *Dreams, phantasy and art*. London: Routledge-The Institute of Psycho-Analysis.

Steiner, Riccardo. (1999). Some notes on the Heroic Self and the meaning and importance of its reparation for the creative process and the creative personality. *International Journal of Psycho-Analysis*. 80, 685–718.

## HESNARD, ANGÉLO LOUIS MARIE (1886–1969)

A psychoanalyst, doctor with the French Navy, and professor at the École Principale du Service de Santé de la Marine, Angélo Louis Marie Hesnard was born in Pontivy in the Morbihan, on May 22, 1886, and died in Rochefort-sur-Mer on April 17, 1969. He was co-author of the first French work on psychoanalysis and one of the founding members of the Société Psychanalytique de Paris (SPP). He was the son of Angélo Théodose Hesnard and Lélia Célénis Rosalie Blancon, from a family of judges. His brother Oswald, who had a degree in German, helped him understand Freud's writings.

After completing his studies in Pontivy, he entered the École de Santé de la Marine et des Colonies in Bordeaux on October 20, 1905. A student of Albert Pitres, then of Emmanuel Régis, he wrote his dissertation in 1909 on “Les troubles de la personnalité dans les états d’asthénie psychique,” in which there is a reference to Freud. He continued his military career in Toulon, then, from 1910 to 1912, on the armored cruiser *Amiral Charner* in the Middle East.

Upon his return in 1912 he was appointed assistant at the Clinique des Maladies Mentales at the University of Bordeaux, where he rejoined Emmanuel Régis, who encouraged Hesnard to study Freud. On January 2,

Freud wrote to Karl Abraham, “Today I received a letter from a student of Régis, in Bordeaux, written on his behalf, apologizing in the name of French psychiatry for its present neglect of  $\Psi$ a.” According to a letter to Ernest Jones on January 14, the reference is to the “apologies from the French nation” that Freud received. This was followed in 1913 by the publication of “La doctrine de Freud et de son école” by Emmanuel Régis and Angélo Hesnard in *L’Encéphale*.

*La Psychanalyse des névroses et des psychoses* appeared in 1914. It was a lengthy précis—and as faithful as it was possible to be at the time—of Freud’s principal theories, as Sándor Ferenczi noted in the review of the book he wrote in 1915. This was followed by an examination of the criticisms the theories had received from various authors, and finally by several commentaries, of which Hesnard claimed, after Régis’ death, that he—Régis—was the principal author.

They recognized that “Freud’s system seems to constitute, regardless of what one may say, one of the most important scientific movements of the current psychological period.” Nonetheless, their remarks essentially referred to what appeared to them to be no more than “ingenious assumptions” that were both original and well understood, since—and this is an argument that would be repeated for decades to come—“Freud’s method of conception is based on that of Janet, whom he has constantly been inspired by. Transforming the term ‘psychological analysis,’ employed by Janet, into psychoanalysis has changed nothing in the method used by both students of Charcot.” The causal importance given to sexuality or symbolism was also criticized. While Freud, in his “On the History of the Psychoanalytic Movement” (1914d), concluded that “Régis and Hesnard (Bordeaux) have recently [1914] attempted to disperse the prejudices of their countrymen against the new ideas by an exhaustive presentation, which, however, is not always understanding and takes special exception to symbolism,” he reproached Hesnard for years for this type of finding. In France the work remained the only extensive essay on psychoanalysis for nearly twenty years and was reprinted in 1922 and 1929.

Hesnard spent the war years in Rochefort and on September 16, 1915, married Henriette Aline Vimont. He was supposed to return to Bizerte, Tunisia, in 1917. When he returned to Paris in 1919, he was named professor at the École Principale du Service de Santé de la Marine and assistant in neuropsychiatry at the



Bordeaux school of medicine. His interest in psychoanalysis did not wane, nor did his reticence, and he was appointed rapporteur to the Congrès des aliénistes et neurologistes de langue française de Besançon (Congress of francophone psychiatrists and neurologists of Besançon) in August 1923. The subject was “La Psychanalyse: Valeur étiologique, méthodologique, thérapeutique et psychiatrique de la doctrine.” In his conclusion Hesnard wrote, “It is in this way that psychoanalysis, freed of its terminological errors, its theoretical exaggerations, and its symbolic fictions of semiological research, joins psychiatry, from which it depends, and clinical psychology. . . . It is in this way that this still unwieldy, but highly perfectible, body of doctrine and method, has an incontestable right to our sympathy as scientists and French nationals.”

While on a trip to Toulon he established contacts with young psychiatrists, who, back in Paris, began to practice psychoanalysis. René Laforgue was the first. It was with Laforgue that Hesnard founded, in 1925, the group and the review of the same name, *L'Évolution psychiatrique*, before his departure in June to the Far East. He returned in November 1925, and in August 1926 was present at the Congrès des Aliénistes in Geneva and participated in the first Conférence des Psychanalystes de Langue Française (Conference of francophone psychoanalysts) that was created at that time.

Although he refused to undergo a teaching analysis (a position he maintained until the end of his life), in November 1926 he became one of the founders of the Société Psychanalytique de Paris, of which he was vice president in 1928 and president in 1930, and in 1927 helped found the *Revue française de psychanalyse*, where he was responsible for the “medical section.” He was also a member of the Commission Linguistique pour l'Unification du Vocabulaire Psychanalytique Française (Linguistic commission for the unification of French psychoanalytic vocabulary), where he fought for the harmonization of French psychoanalytic terminology.

Although supported by Laforgue, he was often criticized by Freud. In 1922, in a preface to the second edition of his first important work, he wrote, “Freud’s doctrine, the product not of the French character of Charcot, as has been claimed, but rather of Germanic philosophy, has had no more useful adversary in the search for truth than Restraint, the muse of Latinity.” Over the years, Hesnard’s position would soften and,

in 1926, he dedicated his book, *La Vie et la Mort des instincts*, to Freud: “To Professor S. Freud, I offer, along with the disavowal of my unfair criticisms, the homage of my pure admiration.” When the book was reprinted for the third time in 1929, he noted that he had spent “ten years in understanding psychoanalysis theoretically and five years in acquiring sufficient practical knowledge,” and he softened his initial criticisms.

Nonetheless, Hesnard remained part of a small group of psychiatrists who opposed the more cultural approach to psychoanalysis represented by Marie Bonaparte. They especially rejected the authority of the International Psychoanalytic Association, and even of Freud himself—a division that would nearly lead to a split among their ranks in the late nineteen thirties. On January 23, 1932, Hesnard wrote to Bernard Grasset, whom he was trying, in vain, to treat, “I beg you, forget all that flashiness, the grandiloquence, all those ‘Oedipuses.’ You, as a subtle and marvelously intuitive Gaul, should not let yourself be misled further by those Judeo-Germanic specters of enchantment” (Bothorel, J., 1989).

He was secretary of the Conseil Supérieur de la Marine in Paris in 1938 and was named head of the Service de Santé de la Marine in Algeria and director of the Service de Santé de la Quatrième Région Maritime in 1940, inspector general of the Service de Santé de la Marine in Africa in 1943, and spent the Second World War in Bizerte. In 1942–1943 he wrote an article entitled, “Sur l’israélisme de Freud,” published in 1946, which claimed to be a refutation of the apparent or claimed Jewish influence in Freud’s writings. Nonetheless, Élisabeth Roudinesco maintained that the article was anti-Semitic in spite of Hesnard’s apparent pro-Jewish sentiments (1982). Calumniated and disgraced after the Liberation, from September 1944 to June 1945, he lived with his wife and daughter in Casablanca, where he joined the Socialist Party and gave several talks before returning to Toulon.

Hesnard participated indirectly in the renewal of the SPP and was also one of the members of the honor committee of the group and the review *Psyché*, founded by Maryse Choisy in 1946, which brought together, aside from René Laforgue, religious and academic scholars and Jungian psychologists who had not been admitted to the SPP. He participated in writing the *Dictionnaire de psychanalyse et de psychotechnique*, which was being prepared in 1949, under the direction of Maryse Choisy and later Daniel Lagache.

At this time Hesnard moved into the “Port-Hesnard” villa in the Mourillon quarter of Toulon, where he practiced psychoanalytic therapy. He was criticized for his lack of rigor in his work, a reproach that was used against him during the negotiations intended to reintegrate the Société Française de Psychanalyse (SFP) into the International Psychoanalytic Association (IPA) because he had sided with Jacques Lacan during the June 1953 split. In June 1957 he was dismissed from the SFP for “non-payment of dues and failure to participate in society activities.”

Although he was elected president of the SFP in 1959, one of the “recommendations” of the IPA committee, made during the Edinburgh congress of 1961, stipulated “that the current practice of keeping Doctors Hesnard and Laforgue out of the training program be maintained. With respect to Doctor Hesnard’s students, these can participate in regular analytic training or they will not be admitted as students of the society.” Hesnard again sided with Lacan in 1964 during the foundation of the École freudienne de Paris (Freudian school of Paris) and, in 1968, became a member of its “accreditation committee.”

In 1964, for family reasons, he left Toulon to settle in Nantes, near where he was born, and where he died on April 17, 1969.

There have been references to the “tall, somewhat Olympian silhouette, the luminous eyes and expressiveness” (Picard, 1972) of this complex character, sometimes sarcastically referred to as “the admiral,” whose extensive body of work has had little impact on theory. Following a number of articles written before the war that fall halfway between proselytism and criticism, the bulk of his output was didactic or historical in nature. These include: *Freud dans la société d’après-guerre* (1946), *L’Univers morbide de la faute* (1949), *Morale sans péché* (1954), *Psychanalyse du lien interhumain* (1957), *L’Oeuvre de Freud et son importance pour le monde moderne* (1960), *Les Phobies et la Névrose phobique* (1961), *Psychologie du crime* (1963).

ALAIN DE MIJOLLA

*Work discussed:* *Psychanalyse des névroses et des psychoses, La*.

*See also:* Aimée, case of; Congrès des psychanalystes de langue française des pays romans; *Disque vert, Le*; Ethics; *Évolution psychiatrique (I’ -)* (Developments in Psychiatry); France; Object; *Psyché, revue internationale de*

*psychanalyse et des sciences de l’homme* (Psyche, an international review of psychoanalysis and human sciences); Régis, Emmanuel Jean-Baptiste Joseph; *Revue française de psychanalyse*; Société française de psychanalyse; Société psychanalytique de Paris and Institut de psychanalyse de Paris.

### Bibliography

Bothorel, Jean. (1989). *Bernard Grasset: vie et passion d’un éditeur*. Paris: Grasset.

Hesnard, Angéolo. (1960). *L’Oeuvre de Freud et son importance pour le monde moderne*. Preface by M. Merleau-Ponty, Paris: Payot.

Hesnard-Félix, Édith. (1984). *Le Dr Hesnard et la naissance de la psychanalyse en France*. Ph.D. thesis in philosophy, Paris-I.

Picard, Pierre Alexandre. (1972). Hesnard et le début de la psychanalyse en France. *Psychologie médicale*, IV, 1, p. 73–85.

Régis, Emmanuel and Hesnard, Angéolo. (1913). La doctrine de Freud et de son école (1re partie). *L’Encéphale*, VIII, 10 April 1913, p. 356–378.

———. (1914) *La psychoanalyse des névroses et des psychoses. Ses applications médicales et extra-médicales*. Paris: Félix Alcan.

Roudinesco, Élisabeth. (1982). *La bataille de cent ans. Histoire de la psychanalyse en France* (Vol. 1). Paris: Ramsay.

---

## HETEROSEXUALITY

The terms to designate sexual orientation arose only in the later nineteenth century. “Homosexuality” owes to work by the Austro-Hungarian journalist and literary figure Károly Mária Kertbeny, who wished to reform prevailing sodomy laws in Prussia; in 1868 he coined the term to avoid the pejorative “pederast.” First used in a letter, it gained some currency and in 1880 its binary opposite—“heterosexuality”—appeared in a book by Kertbeny’s friend and colleague, zoologist Karl Jager. Richard von Kafft-Ebing picked up both terms, though not systematically, for use in his *Psychopathia Sexualis*, first published in 1886. Not long afterward, in 1894, the French intellectual Marc-André Raffalovitch used the term “heterosexual” in an article published in the *Archives of Criminal Anthropology*.

In *Three Essays on the Theory of Sexuality* (1905d), Freud’s developmental stage theory gave special force to the implicitly privileged status of heterosexuality in

a normative context. He outlined a biological and psychological program for each individual, to be elaborated by instinctual objects and aims in a trajectory that moves from a polymorphously perverse disposition in infancy to heterosexual object choice in adolescence.

Heterosexuality in recent years has attracted attention as an aspect of gender and sexuality, a new discipline of study in Anglo-American scholarship, combining traditions of feminist scholarship, psychoanalytic theory, and cultural studies.

BERTRAND VICHYN

*See also:* Bisexuality; Ego; Homosexuality; Object, change of/choice of; *Three Essays on the Theory of Sexuality*.

### **Bibliography**

Freud, Sigmund. (1905d). Three essays on the theory of sexuality. *SE*, 7: 123–243.

Katz, Ned. (1995). *The invention of heterosexuality*. New York: Dutton.

### **Further Reading**

Chodorow, Nancy J. (1992). Heterosexuality as compromise formation: A theory of sexual development. *Psychoanalysis and Contemporary Thought*, 15, 267–304.

---

## **HEUYER, GEORGES (1884–1977)**

A professor of child psychiatry at the Paris Medical School and member of the Académie Nationale de Médecine, Georges Heuyer was born in Pacy-sur-Eure on January 30, 1884, and died in Paris on October 23, 1977.

Having lost his father when he was only eighteen months old, he was placed in a boarding school in Pacy, then in Évreux, where his supervisor was the director of the psychiatric asylum—the origin of his interest in psychoanalysis. In spite of his poverty he studied medicine in Paris, where he became friendly with Georges Duhamel, Henri Queuille, Paul Chevalier, and Henri Mondor. After continuing his studies in pediatrics, neurology, and psychiatry, he became an intern, resident, and in 1923, a doctor in the Paris hospital system. In 1925 he was made director of the clinic of child neuropsychiatry, which, in

1949, created the first chair of child psychiatry in France.

The founder of child psychiatry in France and an international spokesman for the field, at the time of his death, Heuyer left behind a considerable body of work, comprising at least ten books and more than eight hundred articles and publications.

He was not a psychoanalyst and the great majority of his work was devoted to child neuropsychiatry, maladjusted children, and criminology. It was Heuyer who first introduced the use of trained psychoanalysts in public hospitals (Eugénie Sokolnicka at Sainte-Anne's hospital in 1921). With Emmanuel Régis, Angélo Hesnard, and Édouard Pichon, he was one of the promoters of psychoanalysis in France, writing the first article on the subject for a medical treatise, *Traité de pathologie médicale*, which was edited by Émile Sergent in 1924.

In 1925 he created a “laboratory” of psychoanalysis in his clinic, run by Sophie Morgenstern, with whom he published several articles. However, Heuyer wrote little on psychoanalysis with the exception of some studies in collaboration with other people. He was also far from being an uncritical supporter of the field and was always ambivalent and, somewhat later in life, often unfair in his estimate of the profession. However, he did introduce and encourage the use of psychoanalytic inquiry and treatment in child psychiatry and recommended that its practitioners have themselves analyzed or become analysts themselves. This was the case for the majority of his assistants, especially Serge Lebovici (assistant from 1946 to 1957), and of his residents, who subsequently helped psychoanalysis (“which has provided us with so many new and essential concepts” he wrote in 1964) assume the key position it currently holds in French child psychiatry.

JEAN-LOUIS LANG

*See also:* Analytic psychodrama; Infantile psychosis; Infantile schizophrenia; *Psyché, revue internationale de psychanalyse et des sciences de l'homme* (Psyche, an international review of psychoanalysis and human sciences).

### **Bibliography**

Heuyer, Georges. (1924). La psychanalyse. In É. Sergent (Ed.), *Traité de pathologie médicale* (Vol. 1, Psychiatrie, p. 35–79). Paris: Maloine.

———. (1936). Préface. In Sophie Morgenstern, *Psychanalyse infantile*. Paris: Denoël.

Heuyer, Georges; and Morgenstern, Sophie. (1927). Un cas de mutisme chez l'enfant. Guérison par la psychanalyse. *Journal de la Société de psychiatrie*, 19, 6.

Lang, Jean-Louis. (1995). Georges Heuyer, l'art médical et la psychanalyse. *Revue de neuropsychiatrie infantile*, 43 (6), 269–273.

———. (1997). *Georges Heuyer, fondateur de la pédopsychiatrie: un humaniste du XXe siècle*. Paris: Expansion scientifique française.

## HIETZING SCHULE/BURLINGHAM-ROSENFELD SCHOOL

Founded in 1927 by Dorothy Burlingham and Eva Rosenfeld under the aegis of Anna Freud, the Hietzing Schule (Hietzing School) was an effort to create a pedagogic experience inspired by psychoanalytic principles with children who were at the same time engaged in analysis.

Small and private (it was sometimes known as the “Matchbox School”), the school was housed in a log cabin built in Eva Rosenfeld’s back yard, in the XIIIe district of Vienna. Peter Blos, who had been engaged as tutor to Burlingham’s four children, was its first administrator. He enlisted his friend Erik Homburger Erikson as one of the teachers.

Rather few students attended the school, about twenty in all. They came from households in which their parents were apt to understand psychoanalysis or to themselves be in analysis. The children of Burlingham and Rosenfeld, Peter Heller (who would eventually write about his experiences), August Aichhorn’s son Walter, and Ernst Halberstadt-Freud, participated in the project, which created something like a “psychoanalytic family.”

Freud’s own 1918 pronouncements on the role that psychoanalysis might play in preventing psychological conflicts (1919a) undoubtedly influenced the way that the school was conceived. Siegfried Bernfeld, close to Anna Freud, a committed socialist who had himself founded the *Kinderheim Baumgarten*, gave a lecture on education on February 25, 1929, the contents of which were published in the *Frankfurter Zeitung*. Psychoanalysis, according to the article, “would provide decisive

arguments in favor of endeavors in modern education to promote the independent creative activity of the child and the retrenchment of authority and punishment” (Heller 1992, p. 80). Similarly, teaching at the Hietzing School was to be free of the constraints of a rigid or official curriculum in favor of a project-based approach. To allow free rein to curiosity and fantasy (though not to acting out) would provide a place for studying topics such as “Eskimos,” for example, around which would be organized ethnographic investigations, creation of drawings and objects, and games.

Important debates took place between the school’s progressives and latitudinarians (Peter Blos and Erik Erikson) and others who thought it was necessary to impose some unpleasant tasks on children, including Anna Freud, Eva Rosenfeld, and August Aichhorn, who managed the school from 1931 to 1932.

Anna Freud, with her teaching experience in a primary school in Vienna and analysis with her father (who was also analyst to both Dorothy Burlingham and Eva Rosenfeld), was one of the first to plan teaching programs based on psychoanalytic principles. She had almost all the children and some teachers in analysis, including Erik Erikson. Although she appreciated progressive advances in education, she was fairly conservative.

The school closed in 1932, in part due to Eva Rosenfeld’s departure for Berlin. Some students found it difficult to adapt to public education; this factor subsequently influenced Anna Freud and Dorothy Burlingham when they founded, in London during the Second World War, the Hampstead War Nurseries and Child Therapy Clinic.

ALAIN DE MIJOLLA

*See also:* Aichhorn, August; Blos, Peter; Burlingham-Tiffany, Dorothy; Erikson, Erik Homburger; Freud, Anna; Rosenfeld, Eva Marie.

### **Bibliography**

Asspignanesi, Lisa and Forrester, John. (1992). *Freud’s women*. New York: Basic Books.

Freud, Sigmund. (1919a [1918]) Lines of advance in psycho-analytic therapy. *SE*, 12: 159–168.

Heller, Peter. (1992). *Anna Freud’s letters to Eva Rosenfeld*. Madison, CT: International Universities Press.

## HILFERDING-HÖNIGSBERG, MARGARETHE (1871–1942)

Margarethe Hilferding-Hönigsberg, an Austrian physician and psychoanalyst, was born on June 20, 1871, in Vienna, and died while being deported to Maly Trostinec in September 1942.

She was from a family of Jewish doctors, who were deeply involved in the social-democratic movement. She was trained to be a teacher in public and private schools, received her baccalaureate degree, and, in 1898, enrolled in the philosophy department of the University of Vienna. She switched from philosophy to medicine and obtained her doctorate in 1903—one of the first female doctors in Vienna. In 1904 she married Rudolf Hilferding, a socialist economist, future minister of finance of the Weimar Republic. In 1907–1908, the family was living in Berlin but Hilferding-Hönigsberg returned to Vienna with her two sons following her divorce. In 1910 she began practicing medicine in a workers' quarter of Vienna, where she was also politically active with the social democrats from 1927 to 1934, working as a district councilor.

In April 1910 Paul Federn proposed Margarethe Hilferding as a candidate for the Vienna Psychoanalytic Society, which led to an in-depth discussion on accepting women into the organization. On April 27, 1910, she became the first woman in the society and, until her resignation, a year-and-a-half later, regularly attended meetings. During the winter 1910–1911 season, she was an auditor at Sigmund Freud's talks at the school of medicine. In January 1911 she gave her first presentation to the Vienna Psychoanalytic Society; it was titled "The Basis of Maternal Love."

In 1911, at the time of the split between Alfred Adler and Sigmund Freud, she sided with Adler and cosigned his letter of withdrawal. After the First World War she was very active in the Verein für Individualpsychologie (Association for Individual Psychology). She worked as a chief physician in offices providing educational counseling in individual psychology and at the Mariahilfer Ambulatorium day hospital. Her seminars, talks, and publications concerned educational issues and the problems of women. In the collection edited by Sofie Lazarsfeld in 1926, "Volkstümliche Schriftenreihe" (Popular Collection), she published *La Régulation des naissances* with a postscript by Alfred Adler.

When the National Socialists came to power, Margarethe Hilferding-Hönigsberg was unable to get out in time. She lost her apartment and was placed in a Jewish old-age asylum in Vienna. On June 28, 1942, she was deported to Theresienstadt. She died while being transported to Maly Trostinec in September 1942.

ELKE MÜHLEITNER

See also: Austria; Wiener psychoanalytische Vereinigung.

### Bibliography

- Hilferding-Hönigsberg, Margarethe. (1919). Der Schleichhandel. *Kampf*, 12, p. 300–304.
- . (1920). Was kostet die auskömmliche Ernährung? *Kampf*, 13, p. 101–105.
- . (1926). *Geburtenregelung. Erörterungen zum 144. Nachw. A. Adler*. Vienna-Leipzig: Moritz Perles.
- Mühlleitner, Elke. (1992). *Biographisches Lexikon der Psychoanalyse (Die Mitglieder der Psychologischen Mittwoch-Gesellschaft und der Wiener Psychoanalytischen Vereinigung 1902–1938)*. Tübingen: Diskord.

## HIRSCHFELD, ELFRIEDE (1873–?)

Born in 1873 and raised in Frankfurt-am-Main, Elfriede Hirschfeld was a patient of Sigmund Freud. She was treated between 1908 and 1914, and appears anonymously in several articles and in his correspondence. The work of Ernst Falzeder (1994) has enabled us to identify the person behind these references.

Freud was reticent about treating Hirschfeld after she had already undergone ten years of psychiatric treatment. She continued to receive treatment from several other psychoanalysts and psychiatrists but the results were inconclusive. She appears for the last time in the correspondence between Freud and Ludwig Binswanger on May 10, 1923, while she was being treated in Binswanger's clinic.

Hirschfeld appears as "Frau A." in the Freud-Abraham correspondence, "Frau H." in the Freud-Pfister correspondence, "Frau C." in the Freud-Binswanger correspondence, and finally as the "thirty-seven year old patient" in the Freud-Ferenczi correspondence. She was the subject of six articles and the origin of three articles from 1913: "An Evidential Dream" (1913a), "Two Lies Told by Children" (1913g), and "The

Disposition to Obsessional Neurosis” (1913i). She is also directly implicated in the following articles: “Psycho-Analysis and Telepathy” (1941d [1921]), “Some Additional Notes on Dream-Interpretation as a Whole” (1925i), and finally in the chapter “Dreams and the Occult” in *New Introductory Lectures on Psycho-Analysis* (1933a [1932]). The list is long enough to establish the importance of Falzeder’s discovery, but we can also confirm that her case serves as the background for the technical articles “Remembering, Repeating and Working-Through” (1914g) and “Observations on Transference Love” (1915a [1914]).

Hirschfeld’s case was described in the three articles from 1913 and, in greater detail, in the article on obsessional neurosis. In it Freud introduced the erotic-anal phase, following the phases of autoerotism and narcissism, which was not present in the first edition of the *Three Essays on the Theory of Sexuality* (1905d). He also introduces the idea of “symptom mobility,” which he does not describe in detail.

After six years of analysis, three articles, references in his correspondence, and in spite of the fact that Freud claimed to have “reached the hard kernel of the illness,” the patient had not made much progress. She was passed from doctor to doctor, seeing Carl Gustav Jung, Oskar Pfister, and finally Ludwig Binswanger, who treated her in his clinic. Freud made a comment to Binswanger that was to have considerable technical significance: “Analytic treatment should be accompanied by institutionalized control” (letter of April 27, 1922). This comment, along with others on then “current” methods of treatment that preceded analysis, appears in Freud’s correspondence with Karl Abraham. It demonstrates Freud’s pragmatism when faced with clinical difficulties.

Based on the evidence, Hirschfeld pushed Freud toward his final position on transference and countertransference. We can now accept that Freud formulated his first ideas about countertransference with reference to Hirschfeld. Everyone understood the notion of healing through love, as formulated by Carl Jung and Max Eitingon (and which is also found in the *Minutes of the Vienna Psychoanalytic Society* [Nunberg, Hermann; and Federn, Ernst, 1962]), in their own way. It is important to remember that it was during this time that Jung was deeply involved with Sabina Spielrein and Sándor Ferenczi with Elma Palos (Haynal, André, and Falzeder, Ernst, 1991). Freud was dealing with a patient who would not now be termed

neurotic, as he wrote, nor schizophrenic, as Eugen Bleuler claimed, but very likely borderline or suffering from “pseudoneurotic schizophrenia.” In these pathologies the symptoms do not mark the return of the repressed but serve as a defense against psychotic collapse.

Of the hundreds of patients that Freud treated in his practice, few were the subject of a monograph (Dora, for example) or an article (the young homosexual of 1919). Some are mentioned in an article and others appear only as signs or abbreviations in the correspondence. It is clear that psychoanalysis is not a purely empirical science and that its theory is firmly based on clinical practice (Lipton, Samuel D., 1977). Additionally, contemporary witnesses and belated analyses of Freud’s treatments have contributed greatly to our understanding of Freudian practice, as well as how its theorization developed over time (Cremerius, Johannes, 1980).

The case of Elfriede Hirschfeld can be read as a female pendant to the Wolfman, to the extent that their treatments took place almost simultaneously. It is worthwhile rereading the introduction of pregenitality based on this case and the use of the primal scene in Freud’s theorization of the Wolfman’s symptoms. It is certain that Freud made progress as a researcher who experimented within this atmosphere of psychiatric nihilism that consisted in providing a diagnosis, then waiting for the illness to run its course. It is likely that his patients recognized this and, depending on their capabilities, benefited from it.

NICOLAS GOUGOULIS

*See also:* Case histories.

### **Bibliography**

- Cremerius, Johannes. (1980). Freud bei der Arbeit über die Schulter geschaut. *Beiheft zum Jahrbuch der Psychoanalyse*, 123–158.
- Falzeder, Ernst. (1994). My grand-patient, my chief tormentor: A hitherto unnoticed case of Freud’s and the consequences. *Psychoanalytic Quarterly*, 63, 297–331.
- Freud, Sigmund. (1905d). Three essays on the theory of sexuality. *SE*, 7, 123–243.
- . (1913a). An evidential dream. *SE*, 12, 267–277.
- . (1913g). Two lies told by children. *SE*, 12, 303–309.

- . (1913i). The disposition to obsessional neurosis: a contribution to the problem of choice of neurosis. *SE*: 12, 311–326.
- . (1914g). Remembering, repeating and working-through (Further recommendations on the technique of psycho-analysis II). *SE*: 12, 145–156.
- . (1915a [1914]). Observations on transference love (Further recommendations on the technique of psycho-analysis III). *SE*: 12, 157–171.
- . (1925i). Some additional notes on dream-interpretation as a whole. *SE*: 19, 123–138.
- . (1933a [1932]). New introductory lectures on psycho-analysis. *SE*: 22, 1–182.
- . (1941d [1921]). Psycho-analysis and telepathy. *SE*: 18, 173–193.
- Hanyal, André, and Falzeder, Ernst. (1991). Healing through love? a unique dialogue in the history of psychoanalysis. *Free Associations*, 21 (2), 1–20.
- Lipton, Samuel D. (1977). The advantages of Freud's technique as shown in the analysis of the ratman. *International Journal of Psycho-Analysis*, 58, 255–274.
- Nunberg, Hermann, and Federn, Ernst. (1962-1975). *Minutes of the Vienna Psychoanalytic Society*. New York: International Universities Press.

## HISTORICAL REALITY

“Historical reality” refers to the real facts and events of the past as they occurred historically, whether they were external or internal to the subject confronted by them. In general, historical reality stands opposed to wishful fantasies and to everything within the mind that may be said to answer to the pleasure/unpleasure principle and its principal mechanism: hallucinatory wish-fulfillment.

To better understand the relevance of historical reality to psychoanalysis, it is important to realize that the conflict between the two fundamental principles of the mental apparatus—the pleasure/unpleasure principle and the reality principle—also has an impact on the past and on the subject's ideas about the past.

On the one hand, history as retained in memory is capable of being reinterpreted and transformed on behalf of the pleasure/unpleasure principle by means of the individual's fantasies, wishes, and defenses. A fantasy that has been cathected and activated by hallucinatory wish-fulfillment behaves as an actual reality,

interfering with the ego's ability to differentiate real events from imagined and hallucinated ones. This view supports the belief in memory's poor reliability when it comes to historical reality, since any memory is likely to have been reorganized on behalf of the pleasure/unpleasure principle.

On the other hand, Freud—and many other psychoanalysts as well—was never able completely to overlook the impact of certain traumatic historical events in the etiology of mental suffering and symptomology. While history can be transformed for the sake of the libidinal economy of the subject, the repression of the historical reality would be incomplete, since it would leave traces as psychic events unfolded. The reality principle must also be capable of being applied to the past and of opposing the pleasure principle. In a way fantasies themselves might be said to indicate the existence of a kernel of historical reality.

Fantasy and historical reality are not strict opposites. Fantasies, as Freud wrote early in his career, are of “mixed blood”—intermediary formulations that fall somewhere between lived reality and the way in which the subject has given it meaning within his libidinal organization of the moment.

Thus in addition to representative forms of the “memory” of events and facts in the past, forms that are likely to be subjected to different kinds of “deferred” reinterpetations and wishes, there are ways of directly recording lived experience that bear witness to the impact of historical reality. The work of reconstructing historical reality is, therefore, potentially possible, and indeed one of the essential goals of psychoanalytic work (Freud, 1937d) is to extend the influence of the reality principle to the past and its representation.

Historical reality and mental reality are not, therefore, strictly at odds. The reality of experience marks history with an imprint that has significance within the current psychic organization, in particular during childhood, on the basis of infantile sexual theories and the narcissism of infantile animism. Debate continues to erupt, however, within psychoanalysis, over the disjunction between historical reality and mental reality, and this suggests the fragility of the synthesis mentioned above. It would seem that the question of the distribution of what is part of actual history—and therefore, “outside” the subject—and what is part of desire still needs to be re-examined, as if the boundary

between inside and outside was fluid and admitted a degree of undecidability essential to mental functioning and internal conflict.

RENÉ ROUSSILLON

*See also:* Construction de l'espace analytique, La; Event; Fantasy; History and psychoanalysis; Internal reality/external reality; Screen memory; Seduction scenes.

### **Bibliography**

- Freud, Sigmund. (1899a). Screen memories. *SE*, 3: 299–322.
- . (1937d). Constructions in analysis. *SE*, 23: 255–269.
- . (1939a). *Moses and monotheism: Three essays*. *SE*, 23: 1–137.
- Roussillon, René. (1995) La métapsychologie des processus et la transitionnalité. *Revue française de psychanalyse*, 59.
- Viderman, Serge. (1970) *La Construction de l'espace analytique*. Paris: Denoël.

## **HISTORICAL TRUTH**

Historical truth, as Sigmund Freud conceived it, can be defined as a lost piece of the subject's lived experience that is accessible only through the work of construction. The term *historical* here refers to origins, which explains why historical truth can be presented as a kernel of truth in formations as diverse as legends, religions, or delusions.

The problem of historical truth can be theorized in a number of ways in the field of history. The fundamental split between the approach of the historian and that of the psychoanalyst has to do with their respective ways of conceiving temporality. For the psychoanalyst, time is blended: Present and past live together in repetition and in the reliving that is a part of the transference. For the historian, by contrast, the past is separate from the present, and even if there are causal links between the two, their order of succession remains immutable, since what endows an event with its historicity is precisely the fact that it occurred at one time that will never be repeated. Thus, seen from a psychoanalytic perspective, historical truth is not the material truth of an event, even if Freud may have believed this early on his works, but rather the truth of a history as it appears through an event. It is the truth of a sequence and not of a point; it requires the reconstruction of phases leading up to the constitution of an

element that can claim the status of truth. Accordingly, historical truth is to be distinguished from material truth—literal truth that is presumed to have a direct referent in reality.

Although Freud spoke a great deal about truth throughout his work, it was toward the end of his work that he essentially developed the notion of historical truth, mainly in connection with “Constructions in Analysis” (1937d) and “Moses and Monotheism: Three Essays” (1939a [1934–38]).

The idea of historical truth is very important in psychoanalysis, because it makes it possible to take off from a realistic conception of the analytic process, as it was present in Freud's early theory centered around trauma, and move toward a more refined, perspective-based conception where the main focus is on the notion of construction and the process of an indirect confirmation of the construction by the analysand, who can thus give it a truth value, even in the absence of a recovered memory. However, the notion of truth remains dependent upon a feeling of certainty. It is not formal, in the sense that it could be considered to be the same thing as exactness.

Two factors must be taken into account here. The first relates to what Freud called intellectual feeling and concerns the degree of conviction brought by an isolated and repressed piece of truth that returns. This “kernel of truth,” a veritable fossil, is the basis for the irresistible claim to truth contained in religious faith as well as in delusional beliefs. This is a “historical” truth, that is, the truth of both the fossil kernel and the sense the subject may have of the process of distortion that is attached to it. In *Moses and Monotheism: Three Essays*, Freud wrote: “An idea such as this has a compulsive character: it *must* be believed. To the extent to which it is distorted, it may be described as a *delusion*; in so far as it brings a return of the past, it must be called the *truth*” (p. 130). “Historical truth” is thus revealed to be distinct from historical exactitude when the latter does not involve this passage by way of the repressed, and the truth is not implicit in historical narration, for this is, on the contrary, the site of compromise and dissimulation, which this time are conscious. However, as Freud wrote in *Moses and Monotheism*: “In its implications the distortion of a text resembles a murder: the difficulty is not in perpetrating the deed, but in getting rid of its traces” (p. 43); the only possibility is thus to follow these guiding fossils



(*Leitfossil*) that open a pathway toward truth through these distortions.

In “Constructions in Analysis,” the dialectic concerning truth is even more subtle, since an erroneous construction can lead the patient to remember a fragment of his or her historical truth. In this case, said Freud, citing Shakespeare’s Polonius, it is as if “our bait of falsehood had taken a carp of truth” (p. 262). The work of interpretation thus entails freeing the fossil from the aggregate of current material encasing it and bringing it back to the point in the past to which it belongs.

SOPHIE DE MIJOLLA-MELLOR

See also: Amnesia; Anticipatory ideas; *Construction de l'espace analytique, La*; “Constructions in Analysis”; Myth of origins; Paranoia; Truth.

### **Bibliography**

Freud, Sigmund. (1937d). Constructions in analysis. *SE*, 23: 255–269.

———. (1939a [1934–1938]). Moses and monotheism: three essays. *SE*, 23: 1–137.

Mijolla-Mellor, Sophie de. (1985). *Vérité ou fantasme de vérité. Métapsychologie et Philosophie*. Paris: Les Belles Lettres.

Viderman, Serge. (1970). *La Construction de l'espace analytique*. Paris: Denoël.

### **Further Reading**

Mijolla, Alain de. (1996). Psychoanalysts and their history. *International Psychoanalysis: The Newsletter of the IPA*, 5 (1), 25–28.

Spence, Donald. (1982). *Narrative truth and historical truth. Meaning and interpretation in psychoanalysis*, New York: W. W. Norton.

## **HISTORY AND PSYCHOANALYSIS**

Freud wrote little about history, in the sense that professional historians understand that term, or about its relationship to psychoanalysis. Nevertheless, three remarks are in order.

From the outset, Freud posited psychoanalytic investigation as being linked to the reconstitution of the patient’s personal history. The aim was to restore this history to patients, with the goal of helping individuals emerge as the subject and agent of their own history through the lifting of the repressions that weighed

it down, and breaking the pattern of repetitions that resulted from it. Initially Freud conceived of this process as a restitution of buried traces in their entirety; he thus readily compared it with the task of the archaeologist who brings to light the strata of a buried past layer by layer. Although he always maintained his fundamental hypothesis—that the psyche forgets nothing—he came to believe that these “traces” undergo constant change as they are reshaped through deferred action and that they can therefore only be known through analysis in this reworked form, as he explained in “Constructions in Analysis” (1937).

If Freud showed little interest in History as it is written by historians, by contrast he took a great interest in the prehistory and anthropology of so-called primitive peoples, above all at the time when he was seeking to substantiate his views on phylogenesis as the basis for individual psychogenesis. This was the period when he wrote *Totem and Taboo* (1912–13a) and *A Phylogenetic Fantasy: Overview of the Transference Neuroses* (1987 [1915]).

Finally, on several occasions Freud undertook a psychoanalytic interpretation of significant personalities from both the past, such as Leonardo da Vinci (“Leonardo da Vinci and a Memory of His Childhood,” 1910), and the present, such as President Woodrow Wilson (*Thomas Woodrow Wilson, Twenty-Eighth President of the United States: A Psychological Study*, with W. C. Bullitt, 1966). Returning to the story of Moses in *Moses and Monotheism: Three Essays* (1939a), he sought to show that the theory that Moses was an Egyptian would account for his mythical role of founder of a monotheistic religion.

It was this type of work, known as psychobiographical studies, that was most influential on certain of his successors. Notably, in this regard, reinterpretations of Nazism in terms of Adolf Hitler’s personality and psychopathology can be cited; see, for example, Saul Friedländer’s *History and Psychoanalysis: An Inquiry into the Possibilities and Limits of Psychohistory* (1975/1978). These studies have often drawn criticism (for example, from Alain Besançon, after a 1974 work in which he tried this approach) for the reductionist tendency of some authors to overlook factors (cultural, economic, social, etc.) operating outside of individual psychic functioning.

The historian and the psychoanalyst would seem to have common interests: both work on memory,

forgetting, and the restitution of traces; for both, the temporal dimension is essential. Both admit that they construct their object of study through the combined use of techniques for gathering factual data and the work of interpretation that endows these data with meaning by fitting them together; moreover, both use narratives as their starting point, and they accept that these narratives come to them constructed through meaning and must be deconstructed and reconstructed within the framework of their discipline.

One difference between them is the fact that while the historian focuses on the effects of time in the collective memory, the psychoanalyst focuses on these effects in the case of an individual person considered as such. This difference might seem to be a minor one, were it not for the substantial difficulties in assessing how these two levels of analysis are connected: How do collective history and individual history fit together? To what extent does History depend on the contingencies of individual fates, and to what extent are these fates shaped by History? The main difficulties, however, are epistemological in nature.

These difficulties have to do with methods: While the historian is at leisure to verify and tally sources using every means at his or her disposal, the analyst is, as a matter of principle—within the framework of “classical” treatment—limited to only what the patient says in the analytic setting. It is impossible to establish whether a given event in the past actually took place as the patient says it did. It has been argued, justifiably, that this is a moot question, that the only event that is certain is that something has been said this way in the here and now, and that therein lies all the “material” of the analysis (see Viderman, 1970, 1977).

The divergence between history and psychoanalysis exists also, and perhaps above all, at the theoretical level. Time does not have the same status in the two disciplines. The psychoanalyst, who can only know past events through their narration in the present, is led to accept two temporalities: a one-directional, linear time in which the narrated events, with their possibility causality, are ordered; and another, two-directional time, in which an event has modified, sometimes profoundly, an earlier event that is thus reshaped. This means accepting a principle of “antegrade” causality that has no analogue in the study of history or, perhaps, in any other discipline.

ROGER PERRON

*See also:* Andersson, Ola; Anzieu, Didier; “An Autobiographical Study”; Bernfeld, Siegfried; Certeau, Michel de; *Construction de l'espace analytique, La; Freud's Self-Analysis*; Ellenberger, Henri Frédéric; Historical truth; International Association for the History of Psychoanalysis; *Leonardo da Vinci and a Memory of His Childhood*; *Moses and Monotheism: Three Essays*; *On the History of the Psychoanalytic Movement*; Prehistory; Psychoanalytic filiations; Psychoanalytic research; Psychobiography; Psychohistory.

### Bibliography

- Besançon, Alain. (1974). *L'histoire psychanalytique: Une anthologie*. Paris: Mouton.
- Friedländer, Saul. (1978). *History and psychoanalysis: An inquiry into the possibilities and limits of psychohistory*. (Susan Suleiman, Trans.). New York: Holmes & Meier. (Original work published 1975)
- Le Beuf, Diane, Perron, Roger, and Pragier, Georges (eds.). (1998). *Construire l'histoire*. Paris: Presses Universitaires de France.
- Mijolla, Alain de. (1996). Psychoanalysts and their history. *International Psychoanalysis: The Newsletter of the IPA*, 5 (1), 25–28.
- Viderman, Serge. (1970). *La construction de l'espace analytique*. Paris: Denoël.
- . (1977). *Le céleste et le sublunaire*. Paris: Presses Universitaires de France.

## HITSCHMANN, EDUARD (1871–1957)

Austrian physician and psychoanalyst Eduard Hitschmann was born in Vienna on July 28, 1871, and died in the United States on July 31, 1957. He was one of Freud's early disciples and remained loyal to him throughout a long career.

Raised in Vienna, Hitschmann was the son of a banker and the grandson of a physician. He attended the University of Vienna Medical School, received his degree in 1895, and initially practiced internal medicine. In 1905 Paul Federn brought him into the Wednesday Psychological Society. By then a well-known physician, he served for a time as the Freud family doctor.

In April 1909, Hitschmann read before the Vienna Psychoanalytic Society a paper entitled “A General Presentation of Freud's Theories” (Nunberg and Federn, 1962) in which he proposed to write a brief exegesis of psychoanalytic ideas. Freud cautioned Hitschmann not to present psychoanalysis as a closed system and insisted on openly acknowledging that there are

domains in which psychoanalysis could lay no clear claim to knowledge. “Furthermore, this work would require that the writer refrain from expressing any of his own ideas” (Nunberg and Federn, 1962, p. 210). Hitschmann went on to write the first concise presentation of psychoanalysis, *Freuds Neuosenlehre: Nach ihrem gegenwärtigen Stande zusammenfassend dargestellt* (1911), which was translated into English as *Freud’s Theories of Neurosis*.

He also wrote numerous biographical studies, including those of Franz Schubert, William James, and Emanuel Swedenborg; these studies were published in *Great Men: Psychoanalytic Studies* (1956).

Hitschmann’s many psychoanalytic publications did not always receive a friendly appraisal by Freud, who maintained a certain intellectual distance in spite of their friendship. He viewed Hitschmann as “quite orthodox” (Freud 1974, p. 400), as he remarked to Jung. However, Freud entrusted Hitchensmann to direct the psychoanalytic outpatient clinic, or “Ambulatorium,” when it was established in Vienna in 1922. Hitschmann fled the Nazis in 1938 and sought refuge in London; in 1944 he emigrated to Boston where he worked as a training analyst until his death.

HAROLD LEUPOLD-LÖWENTHAL

*See also:* Internationale Zeitschrift für Psychoanalyse; Lehrinstitut der Wiener Psychoanalytischen Vereinigung; Psychoanalytische Bewegung; Wiener psychoanalytische Vereinigung.

### **Bibliography**

- Becker, Philip L. (1966). Edward Hitschmann, 1871–1957, Psychoanalysis of great men. In Franz Alexander, Samuel Eisenstein and Martin Grotjahn (Eds.), *Psychoanalytic Pioneers*. New York: Basic Books Inc.
- Freud, Sigmund. (1974a). *The Freud/Jung letters: The correspondence between Sigmund Freud and C.G.Jung*. Princeton: Princeton University Press.
- Hitschmann, Eduard. (1911). *Freud’s theories of the neuroses, by Dr. Eduard Hitschmann*. Authorized translation by Dr. C.R. Payne, with an introduction by Ernest Jones. New York, Moffat, Yard and company, 1917. 257 p.
- . (1956). *Great men: psychoanalytic studies*. New York: International Universities Press.
- Nunberg, Hermann; and Federn, Ernst. (1962). *The Minutes of the Vienna Psychoanalytic Society. Vol. I, 1906–1908*. New York: International. Universities Press.

## **HOFFER, WILLI (WILHELM) (1897–1967)**

Willie Hoffer, British physician and psychoanalyst, was born in Luditz, Austria in 1897, and died on October 25, 1967, in London.

Educated in Pilsen and Vienna, he became keenly interested in biology and psychology, and took a Ph.D., the thesis for which concerned play as a means of education. He was analyzed by Herman Nunberg from 1921 to 1922. Although he first joined the Viennese Psychoanalytical Society in 1923 as a non-medical member, he studied and qualified in medicine in 1929.

In Vienna, Hoffer worked closely with Anna Freud, and when the Freud family and others left for London in 1938, he too came to London and remained a staunch supporter and in many ways a protector of Freud’s youngest daughter. Anna Freud repeatedly consulted him on many important matters and strongly relied on his judgement. He was a consultant at the Hampstead Child Therapy Course and Clinic, which was founded by Anna Freud and Dorothy Burlingham.

Hoffer obtained a British medical qualification in 1943 and taught at the Maudsley Hospital, as Consultant Psychotherapist, from 1954 to 1962. In 1949 he was elected Editor-in-Chief of *The International Journal of Psycho-Analysis*. In 1957 he resigned this post to become President of the British Psycho-Analytical Society for the following three years; he had already, in 1957, been elected an Honorary Vice-President for life of the International Psychoanalytical Association. His many other honors included appointments as Abraham Flexner Lecturer in Nashville, Tennessee in 1953 and Sigmund Freud Lecturer in New York in 1966. Of his tours abroad, his help in re-establishing psychoanalysis in post-war Germany through repeated visits to teach in Frankfurt were particularly appreciated.

Hoffer wrote a great deal. His best-known work is perhaps his paper on “Mouth, Hand and Ego-Integration” (1950), followed the next year by a paper on oral aggressiveness and ego development. He was also fascinated by young children and what could be learned by studying them. Anna Freud, in a memorial address in 1968, emphasized his “unique role in laying the foundations for a sound and well-planned approach to the study of children of all ages” and reminded her audience that he had set up, in Vienna, a

psychoanalytic training course for teachers, graduates of which were spread all over the western world.

His interest in children was reflected in his writings on play, fairy tales, and education, but his interests were wide and his papers included work on the psychoanalytic investigation of brain damage, schizophrenia, group formation, metapsychology and analytic technique. Hoffer based much of his work on clinical observation and he was at all times a careful writer whose works were frequently revised before publication.

His warmth and personal qualities made him very popular in the British Society, and his work was appreciated by many outside his own group. His wife Hedwig was a non-medical psychoanalyst with whom he lived happily and to whom he was close in every way; her death in 1961 was a very heavy blow to him, and although he faced it bravely, it left its mark.

CLIFFORD YORKE

*See also:* Controversial Discussions; *Gesammelte Werke*; Great Britain; *International Journal of Psychoanalysis*, *The*; Lehrinstitut der Wiener Psychoanalytischen Vereinigung; Wiener psychoanalytische Vereinigung.

### **Bibliography**

- Hoffer, Willi. (1947). Diaries of adolescent schizophrenics (hebephrenics). *Psychoanalytic Study of the Child*, 2, 293–312.
- . (1950). Mouth, hand and ego integration. *Psychoanalytic Study of the Child*, 3–4, 49–56.
- . (1955). *Psychoanalysis: Practical and research aspects*. Baltimore: Williams & Wilkins.
- . (1956). Transference and transference neurosis. *International Journal of Psycho-Analysis*, 37, 377–379.
- . (1968). Notes on the theory of defense. *Psychoanalytic Study of the Child*, 23, 178–188.

## **HOGARTH PRESS**

The Hogarth Press was born in the dining room of the home of Leonard and Virginia Woolf (Hogarth House) in Richmond, Surrey. It was devised largely as a hobby for its owners, with whose literary views it was closely identified; but their standing as writers and critics of substance meant that the small press, concerned more with standards than with profit, attracted

a reputation for quality that brought the imprint renown.

In 1924 the Press moved to more substantial premises in Tavistock Square in London. Between 1921, when Virginia Woolf's *Monday or Tuesday* was launched, and 1938, thirty-three titles are listed in the *Annals of English Literature 1475–1950*, all of high quality, though the first pamphlet was published in 1917. The press became a self-supporting business with a high reputation, particularly in the area of literature. It became an allied company of Chatto and Windus in 1946. By that time, if pamphlets and little series of essays are included, 527 titles had appeared. Apart from writers either famous or later to become so, such as T.S. Eliot, Robert Graves, Katherine Mansfield, C. Day Lewis and Virginia Woolf herself, issues such as disarmament, the League of Nations, educational reform and racial prejudice were tackled. Hogarth was recognized as a foremost publisher of challenging new ideas and major writing. The Press retained this reputation after the alliance with Chatto and Windus.

Seven psycho-analytic works, including Freud's *Beyond the Pleasure Principle* (1920a), *Group Psychology and the Analysis of the Ego* (1921c) and the first volume of his *Collected Papers*, were translated from the German under the editorship of Ernest Jones, assisted by James Strachey and published in Britain between 1921 and 1924. But in that year, negotiations were completed with the Hogarth Press, who added the seven numbers of what was entitled *The International Psycho-Analytical Library* to its list. A partnership was struck with the Institute of Psycho-Analysis in London, who became co-publishers, Leonard Woolf retaining a right of veto, though there is no record that this was ever exercised.

The Library accepted for publication only works of the highest standard, most of which were kept in print for long periods. Karl Abraham, Sandor Ferenczi, Anna Freud and Heinz Hartmann were among its many distinguished authors. The enterprise was so successful that Leonard Woolf agreed to publish a *Standard Edition of the Complete Psychological Works of Sigmund Freud* in a new translation under the general editorship of James Strachey, with the collaboration of Anna Freud and the assistance of Alix Strachey and Alan Tyson. The first of twenty-four volumes appeared in 1953 and the last in 1966. The whole is a triumph of scholarship, with extensive notes and editorial

introductions: no comparable collection of Freud exists anywhere in the world. Woolf is said to have described the decision to publish the work, with understatement, as “rather fortuitous.”

Unhappily, for reasons that have never been fully disclosed, the Institute of Psycho-Analysis, against the wishes of the then editor of the *International Library*, Clifford Yorke, decided to discontinue the Library, and the last of the series, number 118, *Freud's Self-Analysis* by Didier Anzieu, was published in 1986. However, the link with Hogarth as co-publishers of the *Standard Edition*, which has maintained its international success, continues. A new edition is now planned, with a scholarly update of Strachey's editorial apparatus, with additional papers by Freud that were either unknown or unavailable at the time of the first edition, with new refinements. In this venture, the American publisher Norton will join the Hogarth Press and the Institute of PsychoAnalysis. It will be two or three years before the new edition is ready for publication.

The Hogarth Press has maintained its identity, together with Chatto and Windus, even though it is now part of the Random House publishing group.

CLIFFORD YORKE

*See also:* British Psycho-Analytical Society; Glover, James; Great Britain; Jones, Ernest; *Standard Edition of the Complete Psychological Works of Sigmund Freud*.

## HOLDING

Holding is the process by which the mother's capacity to identify with her infant enables her to provide sensitive physical support, especially when the child is physiologically vulnerable. This provision of ego support is a “form of loving” that provides the basis for the establishment of integrated psychological development.

Donald Winnicott presented his ideas on holding and infant development to the public, and to those directly responsible for infant care (1947), and formulated these in psychoanalytic terms at the 22nd International Psychoanalytic Congress at Edinburgh in his seminal paper “The Theory of the Parent-Infant Relationship” (1960).

Sensitive physical handling by the mother allows the baby to tolerate frustrations such as hunger and discomfort and experience the gradual diminishment of his sense of omnipotence without going to pieces. Holding, at the beginning, is a series of physical acts which include responding to the baby's skin, feeding, and a group of sensory sensitivities built into the whole routine of day to day care. This is continued as necessary ego support throughout childhood and adolescence.

When practicing as a pediatrician during and after World War II, Winnicott addressed many groups, including parents and nursery care workers, about the essential qualities of infant care. In describing the minute details of ordinary breast-feeding, he was able to demonstrate how the “good-enough mother” provides sensitive physical and psychological holding of her baby. She identifies with her infant to know how the child feels and to provide just what it needs. In the holding phase, this fosters the baby's apparent belief that what it wanted, it created. It has then a hopeful sense of itself in the present and over time. Successful holding provides the baby with the feeling of reliability in the world, both internal and external. The average mother provides this reliability almost without thinking; and by small increments of frustration allows her baby to become “disillusioned” and aware that there is a “me” and “not-me” and a world that in fact it cannot control. Successful holding is the mothers handling of her infant through a “mutuality of cross identifications” and leads to an integration of the self.

Winnicott is clear that these processes in infancy are not the same as the pathological mental mechanisms of the disturbed or borderline adult patient, but those infants who have been significantly “let down” (1970) experience unthinkable anxieties and the later possibility of schizoid states. Winnicott also described holding within the analytic relationship and more broadly in casework with adult patients (1960). When the analyst's mind wanders, it can be experienced by the patient as a failure to “hold” the mind.

Although mention is made of the father's role in later phases (1960), Winnicott focuses his attention more on the immediacy of the mother-baby interaction and less on the conditions within the adult couple and family needed to foster a successful holding phase.

PAUL CAMPBELL

*See also:* Breastfeeding; Breakdown; Dead mother complex; Framework of the psychoanalytic treatment; Good-enough mother; Handling; Integration; Maternal; Maternal care; Object; Protective shield, breaking through the; Psychosomatic limit/boundary; Self-mutilation in children; Splitting of the object.

### **Bibliography**

Anthony, E., and Benedek, T. (Eds.). (1970). *Parenthood: Its psychology and psychopathology*. Boston: Little, Brown.

Winnicott, Donald W. (1964). Further thoughts on babies as persons. In his *The child, the family and the outside world* (p. 85–92). Harmondsworth, Penguin Books. (Original work published 1947)

———. (1960). The theory of parent-infant relationship. *The maturational processes and the facilitating environment*. London, Hogarth, 1965, p. 17–55.

———. (1970). The mother-infant experience of mutuality. In E. Anthony, T. Benedek (Eds.), *Parenthood: Its psychology and psychopathology*. Boston: Little, Brown.

## **HOLLITSCHER-FREUD, MATHILDE (1887–1978)**

The eldest daughter of Sigmund Freud, Mathilde was born on October 16, 1887, in Vienna, and died in London on February 20, 1978.

Mathilde, named after Josef Breuer's wife, appeared in Freud's dreams as his only reference to oedipal and fatherly feelings (1900a). A sickly child, Mathilde suffered from several serious illnesses, including bouts with diphtheria, and references to her health problems as an adolescent and even after her marriage appear often in her father's correspondence.

When she was twenty and doubted her physical appearance, Freud wrote:

You know that I have always intended to keep you at home until you are at least twenty-four, until you are strong enough for the duties of marriage and possibly of bearing children, and until the weakness, which those three serious illnesses in your early life left behind, has been repaired. In social and material circumstances like ours, girls quite rightly do not marry during their early youth; otherwise their married life would be over too soon. . . . I think you probably associate the present minor complaint with an old worry about which I should very much like to talk to you for once. I have guessed for a long time

that in spite of all your common sense you fret because you think you are not good-looking enough and therefore might not attract a man. I have watched this with a smile, first of all because you seem quite attractive enough to me, and secondly because I know that in reality it is no longer physical beauty which decides the fate of a girl, but the impression of her whole personality. Your mirror will inform you that there is nothing common or repellent in your features. . . . The more intelligent among young men are sure to know what to look for in a wife—gentleness, cheerfulness, and the talent to make their life easier and more beautiful (March 26, 1908) (Freud 1960, pp. 271–272).

Despite Freud's vague plan that she marry Sándor Ferenczi, seven months later he announced her engagement to "a young Viennese businessman named Robert Hollitscher" (1875–1959) whom she married at the synagogue the same day (February 7, 1909) as her uncle, Freud's brother Alexander, married.

In September 1912 Freud interrupted his vacation to go to Mathilde's bedside. A botched appendectomy from six years earlier, which had then carried a risk of peritonitis, had caused her to suffer a miscarriage.

Mathilde remained childless but, after the death of her sister Sophie in 1920, she took charge of young Heinele (Heinz Rudolf Halberstadt). "My eldest, Math[ilde], and her husband," Freud told some friends, "have virtually adopted him and have fallen in love with him so thoroughly that one could not have predicted it." (Gay 1988, p. 421) But Heinele died on June 19, 1923.

In Vienna, Mathilde became friends with Ruth Mack Brunswick, who named her eldest daughter after her. After her husband's business suffered during the Great Depression, Freud helped financially while Mathilde opened a fashionable women's clothing store.

Mathilde and her husband managed to emigrate to London on May 26, 1938, and so welcomed Freud at his arrival shortly thereafter. Mathilde Hollitscher opened another clothing store on Baker Street. She retired in 1960 and died on February 20, 1978 at age ninety-two.

ALAIN DE MIJOLLA

*See also:* Berggasse 19, Wien IX; Freud-Bernays, Martha; Irma's injection, dream of; Mathilde, case of.

### **Bibliography**

- Appignanesi, Lisa; and Forrester, John. (1992). *Freud's women*. New York: Basic Books.
- Freud, Sigmund. (1960a [1873–1939]). *Letters*. New York: Basic Books.
- Gay, Peter. (1988). *Freud: A life for our time*. New York: Doubleday, 1988.
- Gödde, Günther. (2003). *Mathilde Freud. Die älteste Tochter Sigmund Freud in Briefen und Selbstzeugnissen Gieben*. Giessen: Psychosozial-Verlag.
- Jones, Ernest. (1957). *Life and work of Sigmund Freud*. (Vol. 3). New York: Basic Books.

---

## **HOLLÓS, ISTVÁN (1872–1957)**

István Hollós, the Hungarian physician, psychiatrist, and psychoanalyst, was born in Budapest in 1872 and died there in 1957.

The son of a modest artisan (a Jewish tailor, called Heszler before he Magyarized his name), he studied medicine at the Royal School in Budapest. He met Sándor Ferenczi at the beginning of the century and participated in the foundation of the Psychoanalytic Association of Budapest (1913), of which he was vice-president. He worked as an analyst, then did a short analysis with Freud in 1918, followed by control analysis in Vienna with Paul Federn, an analyst specializing in psychotic patients. He was president of the Hungarian Psychoanalytic Society from 1933 to 1939.

He was appointed director of the famous Lipotmező clinic near Budapest, also known as the “Yellow House.” He was close to Ferenczi’s circle and opened the doors of his asylum to writers (Kosztolányi and Karinthy) who were interested in psychotic patients and their linguistic productions. During the period of the Hungarian Commune he taught in the university as a psychiatric “exhibitor.” He translated Freud into Hungarian, first *The Interpretation of Dreams*, finished in about 1917, revised by Ferenczi and published by Somlóin about 1934–1935; followed by *The Ego and the Id* with Géza Dukes, published by Pantheon in 1937. In 1925, under the anti-Semitic regime of Miklós Horthy he had to resign his position as director of the asylum. He wrote a moving testimony to the work he did there and addressed it to Freud, who was prompted to wonder about his own “intolerance” with regard to psychotic patients. He continued to

translate Freud and practice as an analyst while maintaining close relations with Ferenczi.

In 1944 thanks to the last minute intervention of the Swedish diplomat Raoul Wallenberg, he and his wife, along with a few other Jews, escaped a tragic death. He wrote an account of the trauma: *Letter from a Survivor (Psyche, 24 (3), 1974)*. Following the death of his wife and a manic episode for which he received treatment, he returned to the Yellow House, where he ended his days.

Hollós was one of the pioneers of a new approach to mental patients who were, as he put it in 1927, “on strike from life.” His sensitivity, empathy, humanistic principles, and analytic practice helped him to transform asylum conditions, thus making him a forerunner of the movement to apply psychoanalysis in psychiatric institutions.

MICHELLE MOREAU RICAUD

*See also:* Ferenczi, Sándor; Hungary.

### **Bibliography**

- Ferenczi, Sándor; and Hollós, István. (1922). *Zur Psychoanalyse der paralytischen Geistesstörung*. Wien : Internationaler Psychoanalytischer Verlag.
- Hollós, István. (1914). Egy versmondo betegröl. *Nyugat, 8*, p. 333–340.
- . (1919). Die Phasen des Selbstbewusstseinsaktes. *Internationale Zeitschrift für Psychoanalyse, 5*, p. 93–101.
- . (1927). Mes adieux à la Maison jaune. *Le Coq-Héron, 100*, 1986.
- . (1933). Psychopathologie alltäglicher telepathischer Erscheinungen. *Imago, 19*, 529–546.

---

## **HOMOSEXUALITY**

The term *homosexuality* designates a sexual orientation in which a person of the same sex is the object.

The term was apparently coined in 1869, from the Greek *homos* (“same”), by K. M. Benkert, a writer who published his works under the pseudonym Kertbeny Karoli. He was a defender of sexual rights, and he used the term “homosexual” during discussions on whether to change paragraph 143 of the Prussian Constitution of April 14, 1851, which punished acts of “unnatural

indecent" committed between men, or between a man and an animal.

It is highly surprising that Freud took no interest in this manifestation of sexual life during the first years of psychoanalysis, despite the abundant literature on the topic by such writers as Jean-Martin Charcot, Valentin Magnan, Richard von Krafft-Ebing, Albert Moll, Magnus Hirschfeld, and others. Though Freud views neurosis as the "negative of perversion" (without mentioning homosexuality), this is because he supposes that psychic processes do not undergo repression in the "pervert." Moreover, the theory of bisexuality (Freud-Fliess) introduces the question, albeit under the veil of biology. However, Freud did undertake to analyze a homosexual patient at the end of the nineteenth century, but the patient concerned apparently committed suicide at Trafoi.

The arrival of Isidore Sadger in Freud's circle in 1906 was to be decisive. As dialogue between him and Freud led to the laying down of an "etiological formula": masculine homosexuality results from a boy's childhood repression of the existence of a "strong" mother and a weak or absent father (Freud, 1910c). In the debate with Sadger, who adhered to the seduction theory, Freud proposed etiological variants in which the boy's arousal is transposed from the mother onto men (1905d [1910]), or else there is identification with the mother, hatred towards boys is converted into love, there is a "narcissistic" fixation on the penis, or we see identification with the mother leading to repression of love for the mother (Nunberg, Federn, 1962–75). The theory of narcissism that developed in tandem with that of homosexuality opened up a path that Freud left relatively unexplored: the transmission of narcissism. Thus, Freud's descriptions in "On Narcissism: An Introduction" (1914c)—"A person may love . . . according to the narcissistic type . . . (a) what he himself is (i.e., himself), (b) what he himself was" (p. 90)—could be supplemented by formulae such as "a person loves that which the other wants him to be" and, eventually, "a person loves in himself that which the other would have liked to have or to be" (p. 90).

The other area barely outlined by Freud in the discussions of the Vienna Psychoanalytical Society is that of the passage from autoerotism to narcissism: "In general, man has two original sexual objects and his later life depends on the one upon which he remains fixated. These two sexual objects are, for each

individual, the woman (the mother, the children's nurse, etc.) and his own person. It is a question of getting rid of both of them and not lingering over them. One's own person is the one which, most often, is replaced by the father; the latter soon enters the hostile position. Homosexuality bifurcates at this point. The homosexual is unable to detach himself from himself so soon" (1914c). This heavily significant appearance of the father-figure was not followed up in the etiology of masculine homosexuality but it was later to be found in the analysis of male paranoia (the Schreber case, reported in "Psycho-Analytic Notes on an Autobiographical Account of a Case of Paranoia [Dementia Paranoides]": 1911c [1910]), in which a pathological defense against homosexuality develops, though the role of the father is never specified. Is he an agent of culture because he brandishes castration in the name of the law that forbids masturbation and the mother? Might he not also fill a role as seducer?

In 1910, homosexuality was defined by the characteristics of the object or the subject, but in 1915, in place of this distinction, Freud returned to the conception he had earlier developed with Fliess: the object is merely the reflection of the bisexual nature of the subject ("Three Essays on the Theory of Sexuality," 1905d [1915]).

Homosexuality in women would remain less well explored ("The Psychogenesis of a Case of Homosexuality in a Woman," 1920a), because the transposition of the etiological formula for men—specifically, excessive love for the father—often works less well.

As Sándor Ferenczi remarked in 1914, drawing a distinction between "subject homoerotism" and "object homoerotism" (*Three Essays on the Theory of Sexuality*, note added in 1920, p. 147), psychoanalysis relied right from the start on a model of the "feminine man" and thus neglected the masculinity present in other homosexual men, just as it ignored the femininity of certain lesbians.

Since the 1970s, as homosexuality became more openly discussed, several authors (Chasseguet-Smirgel, J., et al., 1964; Isay, R. A., 1986) have communicated clinical observations that suggest other etiologies. But the psychoanalytic perspective has again become clouded by the way the question of "gender" has been biologized (Robert Stoller). Gays themselves have embraced theories of innate or physiological homosexuality in order to defend themselves against



the inquisitorial persecution long meted out to them by justice, medicine, and even psychoanalysis.

Nonetheless, a first step towards the lessening of homophobia, on a basis other than that of moral principles, was taken by Freud, who put forward the idea that a manifest sexual tendency (heterosexuality, for instance) could conceal another, opposite tendency that remains latent (such as homosexuality). However, although Freud went along with increasingly progressive attitudes in society, he remained just as reserved as did society—witness this rather ambiguous and nuanced letter that he wrote in 1935 to the mother of a homosexual, whose sexuality he did not view as an illness but as a case of arrested development (while only heterosexuality is treated as normal): “Homosexuality is assuredly no advantage, but it is nothing to be ashamed of, no vice, no degradation; it cannot be classified as an illness; we consider it to be a variation of the sexual function, produced by a certain arrest of sexual development. Many highly respectable individuals of ancient and modern times have been homosexuals, several of the greatest men among them. (Plato, Michelangelo, Leonardo da Vinci, etc.) It is a great injustice to persecute homosexuality as a crime—and a cruelty, too. . . . By asking me if I can help, you mean, I suppose, if I can abolish homosexuality and make normal heterosexuality take its place. The answer is, in a general way we cannot promise to achieve it. In a certain number of cases we succeed in developing the blighted germs of heterosexual tendencies, which are present in every homosexual; in the majority of cases it is no more possible” (*Letters of Sigmund Freud, 1856–1939*, p. 423). However, such permissiveness was contradicted by the fact that from 1920 onwards many psychoanalytic societies refused to admit openly homosexual candidates.

The response to the theoretical and practical debate around homosexuality was nevertheless present, in embryonic form, in Freud’s conceptualization of the sexual instinct in 1905. Indeed, at the beginning of the *Three Essays on the Theory of Sexuality* following Charcot and Magnan, he used the highly inappropriate word “inversion” to prove demonstrate that the instinct has no predefined object.

BERTRAND VICHYN

*See also:* Activity/passivity; Alcoholism; Anality; Dark continent; Eroticism, anal; Female sexuality; Fetishism;

Heterosexuality; Identification; “Leonardo da Vinci and a Memory of His Childhood”; Libido; Narcissism, secondary; Neurosis; Paranoia; Paranoid position; Persecution; Perversion; Phallic mother; Projection; *Psychology of Women, The: A Psychoanalytic Interpretation*, *Psychopathologie de l’échec* (Psychopathology of Failure); Sadger, Isidor Isaak; Suicide; *Three Essays on the Theory of Sexuality*.

### Bibliography

- Bieber, Irving, et al. (1962). *Homosexuality, a psychoanalytical study*. New York: Basic Books.
- Chasseguet-Smirgel, Jacqueline, et al. (1964). *Female sexuality: New psychoanalytic views*. London: Virago.
- Freud, Sigmund. (1960). *Letters of Sigmund Freud, 1856–1939*. (Ernst L. Freud, Ed.; Tania and James Stern, Trans.). New York: Basic Books.
- Isay, Richard A. (1986). The development of sexual identity in homosexual men. *Psychoanalytic Study of the Child*, 41.
- Lewes, Kenneth. (1988). *The psychoanalytic theory of male homosexuality*. New York: Simon & Schuster.
- Socarides, Charles W. (1978). *Homosexuality*. New York: Jason Aronson.

### Further Reading

- Friedman, Robert. (1988). *Male homosexuality. A contemporary psychoanalytic perspective*. New Haven and London: Yale University Press
- Roughton, Ralph. (2002). Rethinking homosexuality: What it teaches us about psychoanalysis. *Journal of the American Psychoanalytic Association*, 50, 733–764.

## HORNEY-DANIELSON, KAREN (1885–1952)

Karen Horney, physician and psychoanalyst, was born Karen Danielson in a suburb of Hamburg, on September 15, 1885, and died December 4, 1952, in New York.

Her father was a sea captain of Norwegian origin, her mother of Dutch-German extraction. She studied medicine at the Universities of Freiburg, Göttingen, and Berlin, and married Oskar Horney in 1909. She entered analysis with Karl Abraham in 1910, and became a founding member of the Berlin Psychoanalytic Institute in 1920.

Having separated from her husband in 1926, Horney emigrated to the United States in 1932, when Franz Alexander invited her to become associate

director of the newly formed Chicago Psychoanalytic Society and Institute. She moved to New York in 1934 and became a member of the New York Psychoanalytic Institute. In 1941, she organized the American Institute for Psychoanalysis, of which she was dean until her death in 1952. She was founding editor of *The American Journal of Psychoanalysis*.

Horney's thought went through three phases: in the 1920s and early 1930s, she wrote a series of essays in which she tried to modify orthodox ideas about feminine psychology while staying within the framework of Freudian theory. In 1930s, she tried to redefine psychoanalysis by replacing Freud's biological orientation with an emphasis on culture and interpersonal relationships. In the 1940s, she developed her mature theory in which individuals cope with the anxiety produced by feeling unsafe, unloved, and unvalued by disowning their spontaneous feelings and developing elaborate strategies of defense.

Disagreeing with Freud about penis envy, female masochism, and feminine development, Horney's early essays were largely ignored until they were published in *Feminine Psychology* in 1967. Since then, there has been a growing recognition that Karen Horney was the first great psychoanalytic feminist.

As the author of *The Neurotic Personality of Our Time* (1937) and *New Ways in Psychoanalysis* (1939), Horney is often thought of as a neo-Freudian member of "the cultural school," a group that also included Erich Fromm, Harry Stack Sullivan, Clara Thompson, and Abram Kardiner. These two books proposed a model for the structure of neurosis in which adverse conditions in the environment as a whole, and especially in the family, create a "basic anxiety" against which the child defends itself by developing strategies of defense that are self-alienating, self-defeating, and in conflict with each other. In a striking departure from Freud, Horney advocated focusing on the current constellation of defenses and inner conflicts rather than with infantile origins.

In her next book, *Self-Analysis* (1942), Horney presented her fullest account of how the psychoanalytic process works in terms of her structural paradigm. The object of therapy for Horney is to help people relinquish their defenses, which alienate them from their real selves, so that they can get in touch with their true likes and dislikes, hopes, fears, and desires.

In her mature theory, developed in her last two books, Horney argued that people defend themselves against their anxieties by developing both interpersonal and intrapsychic strategies of defense. She described the interpersonal strategies most fully in *Our Inner Conflicts* (1945). They involve moving toward, against, or away from other people and adopting a compliant, aggressive, or detached solution. Since people tend to employ more than one of these strategies, they are beset by inner conflicts. In order to avoid being torn apart or paralyzed, they adopt a strategy consistent with their culture, temperament, and circumstances; but the repressed tendencies persist, generating inconsistencies and rising to the surface if the predominant solution fails.

Karen Horney emphasized intrapsychic strategies in *Neurosis and Human Growth* (1950). To compensate for feelings of weakness, inadequacy, and low self-esteem, people develop an idealized image of themselves that they seek to actualize by embarking on a search for glory. The idealized image generates a pride system, which consists of neurotic pride, neurotic claims, and tyrannical shoulds, all of which intensify the self-hate against which they are intended to be a defense. The idealized image is inwardly divided, since it reflects not only the predominant interpersonal strategy but also the conflict between it and the subordinate tendencies.

Horney's mature theory helped to inspire the interpersonal school of psychoanalysis, provided a model for therapies that focus on the current situation, and influenced some of the descriptions of personality disorders in the DSM-III and -IV. It has made an important contribution to the study of literature, biography, gender, and culture. Because of her emphasis on self-realization as the goal of life and the source of healthy values, Karen Horney was recognized by Abraham Maslow as one of the founders of humanistic psychology. Her theory has most in common, perhaps, with the work of Erich Fromm, Ernest Schachtel, Carl Rogers, and Abraham Maslow. Many of Horney's ideas have made their way, often unacknowledged, into the array of concepts and techniques that are currently employed in clinical practice.

BERNARD PARIS

*Work discussed: Neurosis and Human Growth*

See also: Allgemeine Ärztliche Gesellschaft für Psychotherapie; American Academy of Psychoanalysis; Dark continent; Feminine sexuality; Femininity; Feminism and psychoanalysis; Germany; Memory; Second World War: The effect on the development of psychoanalysis; Splits in psychoanalysis; United States.

### **Bibliography**

- Horney, Karen. (1922). *Feminine psychology*. New York, W.W. Norton.
- . (1937). *The neurotic personality of our time*. New York: W. W. Norton.
- . (1939). *New ways in psychoanalysis*. New York, W.W. Norton.
- . (1942). *Self-analysis*. New York: W.W. Norton.
- . (1950). *Neurosis and human growth: The Struggle toward self-realization*. New York, W.W. Norton.
- Paris, Bernard. (1994). *Karen Horney : A psychoanalyst's search for self-understanding*. New Haven, CT: Yale University Press.
- Quinn, Susan. (1987). *A mind of her own: The life of Karen Horney*. New York: Summit Books.
- Westkott, Marcia. (1986). *The feminist legacy of Karen Horney*. New Haven, CT: Yale University Press.

---

## **HOSPITALISM**

René Spitz introduced the term *hospitalism* in his work defining disorders in infants who were institutionalized for long periods and deprived of substitute maternal care. The notion was later expanded to refer more generally to severe and lasting maternal deprivation.

Linked to Sigmund Freud's concept of maternal care according to, hospitalism refers to the most radical effects of deficiencies in this area. Spitz's defining study of the phenomenon concerned abandoned children who had been separated from their mothers at around three months and had lived for five to six months in a nursery that was said to be beyond reproach in terms of nursing care but that was isolated and devoid of human bonding relations for the babies. The pathology analyzed showed the following: overall developmental deterioration; stagnation in height-weight growth; a shift in development ratios; relational

or affective expression reduced to silence; motor and behavioral deviancies; and increased morbidity/mortality rates. Many of these forms of damage were deemed to be irreversible. Spitz categorized hospitalism as "total affective deficiency" and distinguished it from anaclitic depression, categorized as "partial deficiency," which followed at least six months of satisfactory relations with the mother and which could improve once the child was reunited with the mother.

Spitz described these two pathological forms in a pair of publications (hospitalism in 1945, anaclitic depression in 1946) jointly subtitled "An Inquiry into the Genesis of Psychiatric Conditions in Early Childhood." His work emphasizes the vital importance of object relations and the serious consequences of its failure. Additionally, it underscores the relevance of direct infant observation. The baby in reality and the reconstructed baby, placed in a relation of reciprocal reassessment, make possible a wealth of discoveries that validate the research method promoted by Spitz. His concept thus brings us back to the very origins of infant psychiatry, and the first World Congress on Infant Psychiatry, in 1980, was dedicated to his memory.

As a model of deprivation in institutional settings, hospitalism holds a historical place in the design of children's shelters and child-care facilities. The notion received international exposure through a World Health Organization monograph (No. 2, 1951) entitled "Maternal Care and Mental Health"; it was coordinated by John Bowlby, already an established presence in this field ten years prior to his shift in focus to attachment theory.

Spitz's concept of hospitalism drew a number of critical analyses, some on specific points (the inaccuracy of the term itself, lack of precision in pediatric terms, the omission of frequent repeated separation, failure to consider the father's role, etc.), others more general in their scope. These criticisms resulted in some major reassessments in a new World Health Organization monograph published in 1962, whose principal authors included Serge Lebovici and Mary D. Ainsworth.

Study of the short- and long-term consequences of a young infant being separated from its mother remained one of the foremost focuses of childhood psychiatry (Michel Soulé), constantly revised in the light of new discoveries and approaches: the competencies of

infants, relational pathologies, advances in knowledge about the infant's mental functioning, psychosomatic repercussions as the top-ranking psychopathological expressions of frustration in early infancy (Léon Kreisler). With a few major exceptions, forms of hospitalism at the turn of the millennium are less connected to stays in institutions and more often concern the complexity of social and intrafamilial deprivation that children face in contemporary society.

LÉON KREISLER

See also: Abandonment; Anaclysis/anaclytic; Deprivation; Spitz, René Arpad.

### Bibliography

Ainsworth, Mary D. Salter. (1962). The effects of maternal deprivation: a review of findings and controversy in the context of research strategy. In Mary D. Ainsworth and R. G. Andry *Deprivation of maternal care*. Geneva: World Health Organization.

Lebovici, Serge. (1962). Sur la notion de carence maternelle. In *La carence de soins maternels, réévaluation de ses effets*. Geneva: Organisation Mondiale de la Santé.

Soulé, Michel; Lauzanne, Kathlen; and Leblanc, Nelly. (1995). La carence de soins maternels. In Serge Lebovici, René Diatkine, and Michel Soulé (Eds.) *Nouveau traité de psychiatrie de l'enfant et de l'adolescent* (Vol. 4, pp. 2529–2545). Paris: Presses Universitaires de France.

Spitz, René A. (1945). Hospitalism: An inquiry into the genesis of psychiatric conditions in early childhood. *Psychoanalytic Study of the Child*, 1, 53–74.

Spitz, René A. (1946). Anaclytic depression. *Psychoanalytic Study of the Child*, 2, 313–342.

### Further Reading

Spitz, Rene A. (1946). Hospitalism: a follow-up report. *Psychoanalytic Study of the Child*, 2, 113–118.

## HUG-HELLMUTH-HUG VON HUGENSTEIN, HERMINE VON (1871–1924)

The Austrian psychoanalyst Hermine Hug von Hugenstein (usually known as Hermine von Hellmuth) was born in Vienna on August 31, 1871, where she was murdered on September 8 or 9, 1924. She is often regarded as the first child psychoanalyst.

Hug-Hellmuth was the second daughter of Hugo Hug von Hugenstein, who served in the Austrian war

ministry both as a military officer (rising to the rank of lieutenant colonel) and as a civilian. The family was Catholic. After the death of her mother, who had served as her tutor, Hermine entered public school and eventually trained to become a teacher. She taught in public and private schools before entering the University of Vienna in 1897, where she studied the physical sciences. In 1909, she obtained a doctorate in physics.

While a patient of the Viennese analyst Isidor Sadger, Hug-Hellmuth became interested in psychoanalysis. In 1910, she resigned her teaching post and the next year published her first paper on psychoanalysis in the *Zentralblatt für Psychoanalyse*, even before she began to take part in the meetings of the Vienna Psychoanalytical Society. The title of that paper, “The Analysis of a Dream of a 5-Year Old Boy” already indicated her principal interest. In 1913 she published “The Nature of the Child’s Soul (Or Psyche).” The title of that paper subsequently served as the name of a section on child psychoanalysis that she wrote for *Imago*; she also became a regular contributor to the *Internationale Zeitschrift für (ärztliche) Psychoanalyse*. Hug-Hellmuth first participated in meetings of the Vienna Society in 1913, and became a member of the society that fall.

Active and well-known beyond Vienna, Hug-Hellmuth became the first child analyst and contributed to the evolution of child psychoanalysis. At the International Congress in The Hague in 1920, she reported on her early efforts in her paper “On the Technique of the Analysis of Children.” A year later she became director of the Educational Counseling Center associated with the “Ambulatorium” of the Vienna Psychoanalytic Society. Her work, critiqued by both pedagogues and psychologists, was based on observation and analysis of children’s behavior and on the possibility of applying psychoanalytic theory to education and the psychology of children. Her broad application of psychodynamic hypotheses to child behavior contributed to the rejection of psychoanalysis by the field of educational psychology.

Hug-Hellmuth’s *A Young Girl’s Diary* was first published anonymously in 1919 by the Internationaler Psychoanalytischer Verlag, the official psychoanalytic publishing house. The book created a sensation, and was discussed in the daily newspapers as well as in medical and psychological reviews, but its authenticity was questioned. Hug-Hellmuth, who was named as

the book's "editor" in 1922, would not admit to being its real author. In 1927 Freud, who had written an introduction to the book, asked that it be withdrawn from bookstores.

On the night of September 8–9, 1924, shortly after the completion of her book *New Ways to the Understanding of Youth*, Hug-Hellmuth was murdered by her eighteen-year-old nephew, Rolf. The illegitimate child of her half-sister Antoine, he had been raised by Hug-Hellmuth since the death of his mother. According to Rolf, his aunt's writings contained many observations of him and he testified at his trial that she had attempted to psychoanalyze him. After his trial he was sentenced to twelve years in prison. After being released from prison, he attempted to get restitution from the Vienna Psychoanalytic Association, as a victim of psychoanalysis.

ELKE MÜHLEITNER

*Work discussed:* *Young Girl's Diary*, A.

*See also:* Child analysis; Children's play.

### **Bibliography**

- Drell, Martin J. (1982). Hermine Hug-Hellmuth, A pioneer in child analysis. *Bulletin of the Meninger Clinic*, 46 (2), 138–150.
- Hug-Hellmuth, Hermine von. (1919). *A study of the mental life of the child*. New York and Washington; Nervous and Mental Disease Monograph series.
- . (1971). *A young girl's diary*. Boston: Milford House. (Original work published 1924)
- MacLean, George; and Rappen, Ulrich. (1991). *Hermine von Hug-Hellmuth*. New York: Routledge.
- Roazen, Paul. (1976). *Freud and his followers*. New York: Alfred A. Knopf.

---

## **HUMOR**

*Humor* is the name given to the psychic process that operates in the field of the preconscious, based on the dynamic interrelation between the agencies of the mind, and akin to a defense mechanism, consisting of an unexpected re-evaluation of the demands of reality that reverses their painful emotional tone and thereby offers to the triumphant ego that yield of pleasure

which enables it to demonstrate its invulnerable narcissism.

Freud's first insight into the mechanism of this phenomenon, which was entrenched in the family and community life in which he was deeply involved, came in the last pages of *Jokes and their Relation to the Unconscious* (1905c). It was, in fact, on the death of his father that he started to collect Jewish jokes (*Witze*) and, at the insistence of Wilhelm Fliess, developed a theory to explain them, bringing out how their very condition of possibility lay in the activity of this process within the humorist. Although he pointed out (1908c) the kinship between this process and children's games, he did not elucidate it in metapsychological terms until the brief article of 1927 (1927d).

Unlike comedy and wit, or even irony, all of which aim at the satisfaction of erotic or aggressive drives and necessitate, for this purpose, the effective presence of a real third party, humor involves a strictly intrapsychic process of indirection whose purpose is economic, viz., sparing the subject from the painful feelings (pity, irritation, anger, suffering, disgust, tenderness, horror, etc.) that the situation ought to occasion. The energy of these feelings is thus diverted and transformed into the moderate but triumphant pleasure (so different from the explosion of hilarity) that is expressed in the smile of humor. As a result, the humorist reaffirms his narcissistic invulnerability, assuring himself that nothing traumatic can affect him, and that he can in fact find in such things a yield of pleasure.

This being the case, although humor is an autonomous process, it is encountered most often mixed with other forms of the comic, in which it finds a mode of expression, with which it is often confused, and for which it intervenes as a mechanism that inhibits any emotions that would obstruct its development.

Nonetheless, Freud considers humor as a particularly salubrious activity, making of it the rarest and most elaborate form of defense. Yet its benefits turn out in fact to be costly, necessitating a large outlay, since while this economic process, being neither denial nor repression, leads to a reversal of emotional tone, it does not eliminate the painful representation. Freud explained this as the result of a new topographical arrangement: the humorist takes the psychic emphasis off the ego and displaces it onto his superego: "Look! here is the world, which seems so dangerous! It is

nothing but a game for children—just worth making a jest about!” (1927d, p. 166).

In fact, humor leads to a set of notions whose origin, nature, history, and development thus all need to be re-examined, as they all indubitably hark back to the genesis of the ideal psychic agencies and their function in establishing a humorous attitude towards reality. All of these dimensions, indeed—whether it be the invulnerable narcissistic kernel of which the humorist is a living testimony, the exercise of the reality principle, the experience of pain, the mechanism of illusion, or the alchemy of the emotions that it produces—invite reflection on the precocious relations that were formed between the humorist and his mother who bequeathed to him this precious gift (Donnet, J.-L., 1997; Kameniak, J.-P., 1998). For example, we need to reflect—as did Freud—on the enigma of the “essence of the Super-ego,” a superego that manifests itself in an atypical form of functioning: as a reassuring and consoling agency—even a maternal one—that is barely consistent with the severity usually associated with it, whether in the commands it issues or in its role as representative and guardian of the reality principle.

While humor was initially considered as a variety of the comic genre, in the same way as wit (with which it is often confused), Freud early on endeavored to distinguish it through topographical localization, the kind of gratification it affords, the absence of the need for a third person, and, finally, the specific nature of the process, all of which make it a character disposition or trait rather than a random production. Consequently, over and above the defensive use that has been classically recognized and associated with the process of humor, we might want to ask whether it could have a specific function of working-through, very different from the relaxation which is brought about by the comic effect, thus tempering any excess of emotion; how any real “work of humor” is actually accomplished; and what its nature might be. Whereas, when faced with the hostility of events, the risk of trauma may appear to be significant, humor does allow the subject to maintain the integrity of his psychic functions and their availability while also acknowledging the “disruptive” nature of reality. We can surely envisage the possibility (Bergeret, 1973) that there are hints of a working-through involved in humor, or, at the very least, the establishment of the framework needed for any possible integration of the sufferings inflicted on the subject.

Nevertheless, it cannot escape notice that there has been a general lack of interest and a relative silence on the part of contemporary analysts when it comes to this subject, apparently so frivolous though in fact it raises fundamental questions. Up until now, analytic literature on this theme has scarcely extended beyond a few scattered remarks or occasional articles, and most of them use humor as a generic category succeeding that of “the comic” proposed by Freud. Consequently, they are more likely to discuss the techniques and procedures of the modes of expression to which humor resorts than to examine the process of humor itself.

JEAN-PIERRE KAMENIAK

*See also: Almanach der Psychoanalyse; Creativity; Jokes and their Relation to the Unconscious; Paradox.*

### **Bibliography**

- Bergeret, Jean. (1973). Pour une métapsychologie de l'humour. *Revue française de psychanalyse*, 37, 4.
- Donnet, Jean-Luc. (1997). L'humoriste et sa croyance. *Revue française de psychanalyse*, 61, 3.
- Gay, Peter. (1990). *Reading Freud: Explorations and entertainments*. New Haven: Yale University Press.
- Kameniak, Jean-Pierre. (1998). *Freud, un enfant de l'humour*. Lausanne-Paris: Delachaux & Niestlé.
- Shentoub, Salem A. et al. (1989). *L'Humour dans l'oeuvre de Freud*. Paris: Two Cities.

### **Further Reading**

- Poland, Warren S. (1990). Gift of laughter: Development of a sense of humor in clinical analysis. *Psychoanalytic Quarterly*, 59, 197–225.

---

## **HUNGARIAN SCHOOL**

Fundamentally, the “Hungarian School” denotes a trend of thought developed by psychoanalysts who worked in Budapest between the two world wars. Its representatives worked independently. They shared a theoretical view that did not recognize primary narcissism. From the beginning, they attributed a prominent role to the mother-child relationship. As part of this work, they contributed to the instinct theory (clinging instinct, Imre Hermann) and the role of psychological deficiency (Sándor Ferenczi, Michael Balint).

Commitment to treatment was emphasized, which gave rise to methodological experiments (Ferenczi) and led to two-person psychology (Michael Bálint). They contributed to the development of ethno-psychoanalysis (Geza Róheim) and psychoanalytical psychosomatics (Franz Alexander), and the introduction of psychoanalytical pedagogics (Ferenczi, Imre Hermann, Michael Bálint).

The school was founded by Ferenczi as an analytical circle around him in Budapest. In 1913 the Hungarian Psychoanalytical Society was founded which, together with the Viennese Society, became the most important intellectual center in Europe. The cultural-social atmosphere of the age was, in many respects, favorable for the development of psychoanalysis; reputed writers and also joined the group. Freud supported the idea that psychoanalysis should have several centers. At the end of WWI in 1918, the International Congress was held in Budapest and plans were made to found the first psychoanalytical institution there.

The 1920s were the golden age of the Hungarian School. Ferenczi's theoretical work and methodological experiments mark this period. Several creative analysts among his students acquired worldwide repute (Alexander, Alice Bálint, Melanie Klein, Róheim, René A. Spitz). With regard to training, Ferenczi advocated the introduction of compulsory personal analysis of greater depth than in the case of patients. This gave rise to the development of the Budapest model of supervised analysis (Vilma Kovács).

Ferenczi's death and the political situation in the 1930s, and specifically the persecution of Jews, caused many to emigrate (Sándor Radó, C. Robert Bak, Alice Bálint, Michael Bálint, Róheim), and many of those who remained in Budapest fell victim to fascism during WWII. By the end of the 1930s the Hungarian School as an intellectual community had lost its significance. Many of the emigrant analysts preserved the spirit of the School in their work in their adopted country (the Bálints and E. Gyömrői in England; Alexander, Therése Benedek, Sándor Lóránd, Margaret Mahler, Radó, Danièle Rapaport, Róheim, and Spitz in the U.S.). The small group in Budapest continued their scientific activity.

After 1945, there was a brief period of upswing, but in 1949 the communist government banned the society and psychoanalysis was forced into semi-illegality. Its representatives—led by Imre Hermann—

ensured the survival of psychoanalysis, passing on the spirit and traditions of the Hungarian School. In the 1970s, psychoanalysis was reinstated (1975—study group; 1983—provisional society; 1989—component society).

The Hungarian School may be said to have two distinctive features. One is that its original representatives catalyzed the development of psychoanalytical theory and techniques. They discovered and described a number of phenomena which have continued to constitute the foundation of psychoanalysis. The other is the "Ferenczi phenomenon," according to which only the essential development of psychoanalysis makes the integration of theoretical and methodological work possible.

#### HUNGARIAN GROUP

See also: Ferenczi, Sándor; Hungary.

#### Bibliography

- Harmat, Pál. (1988). *Freud, Ferenczi und die Psychoanalyse in Ungarn*. Tübingen: Diskord.
- Harmatta János, Szónyi, Gábor. (1992). Hungary. In P. Kutter (Ed.), *Psychoanalysis international, a guide to psychoanalysis throughout the world*, (Vol. 1, Europe, p. 173–184). Stuttgart-Bad Cannstatt: Frommann-Holzboog.
- Hidas, György. (1987). Die Psychoanalyse und ihre Schicksale in Ungarn. *Sigmund Freud House Bulletin*, 11 (2), 1–12.
- Nemes, Livia. (1985). The fate of the Hungarian psychoanalysts during the time of fascism. *Sigmund Freud House Bulletin*, 9, 20–28.
- Vikár, György. (1994). Der Beitrag der Budapester psychoanalytischen Schule zur Objektbeziehungstheorie. *International Forum for Psychoanalysis*, 10, 52–60.

## HUNGARY

Hungary, a country that was primarily agricultural until the mid-nineteenth century, entered the modern era in 1867 with the creation of the Austro-Hungarian monarchy. At the start of the twentieth century, in Budapest, which had become a center of cultural life, a group of radical intellectuals demanded the democratization of a country that had remained semi-feudal. Unable to compete in the political sphere, they created institutions like the Free School of Social Science,

reviews like *Huszadik Század* (Twentieth Century) and *Nyugat* (Occident), to achieve their goal by means of education. For psychoanalysis the Hungarian intelligentsia was fertile terrain, for it held that the liberation of the individual and the liberation of society went hand in hand.

Psychoanalysis was introduced to Hungary by Sándor Ferenczi, who was its leading exponent. A young neurologist, Ferenczi encountered Freudian theory through Carl Gustav Jung's word association test and through the literature of analysis. After his first visit to Freud in February 1908, he quickly became an integral part of the Vienna group and assumed the responsibility of bringing psychoanalysis to Hungary. His efforts were well received in literary and artistic circles, as shown in the writings of Géza Csáth, Dezső Kosztolányi, Mihály Babits, and Frigyes Karinthy, while most physicians remained reticent.

The Hungarian Psychoanalytic Association was founded by Ferenczi in 1913. In addition to Ferenczi, its members included the psychiatrist István Hollós, the physician Lajos Lévy, the medical student Sándor Radó, and the journalist and writer Hugó Ignó (Hugó Veigelsberg), the editor-in-chief of *Nyugat*.

During World War I, Ferenczi, who had been mobilized, cared for soldiers who had suffered trauma during combat. The psychoanalytic treatment of war neuroses drew the attention of Hungarian officials, with the result that the Fifth Congress of Psychoanalysis, organized in Budapest on September 28 and 29, 1918, was held at the Academy of Sciences in the presence of government representatives. During the congress, Antal (Anton) von Freund, who ran a large beer hall, but also had a PhD in philosophy, a patient and friend of Freud, provided funding for the creation of a psychoanalytic clinic and publishing house. Ferenczi was elected president of the International Psychoanalytic Association, but the political upheavals that shook the country, especially Hungary's independence from Austria, the democratic revolution, the Bolshevik revolution in Budapest in 1919 and its brutal repression, forced him to yield the presidency to the Briton, Ernest Jones.

During the democratic government of Mihály Károlyi, students and progressives demanded that psychoanalysis be officially recognized. Their demand reached the Commune and Ferenczi was appointed professor of psychoanalysis at the university, the first

in the world. When the right-wing government of Miklós Horthy came to power, the position was eliminated and, in 1920, Ferenczi was excluded from the Hungarian medical association.

The 1920s turned out to be a phase of expansion for psychoanalysis in Hungary. At the end of the war, Géza Róheim, Imre Hermann, Zsigmond Pfeifer, and other leading figures joined the Hungarian Psychoanalytic Association. Cut off from playing a role in Hungarian public life, psychoanalysts consulted, taught, and published. Róheim developed the notion of psychoanalytic anthropology, Hermann worked on the psychology of creativity, Pfeifer on children's games. This was also the period of the first wave of emigration. Sándor Radó and Jenő Hárnik moved to Berlin and participated in the creation of the Institute for Psychoanalytic Training. During the twenties, József Eisler, Sándor Feldmann, Erzsébet Révész, Béla Felszeghy, Vilma Kovács, and Alice and Mihály Bálint joined the association.

Efforts were made to organize the teaching of psychoanalysis. Seminars on theory were established in 1919, and in 1925 a training method specific to Hungary was developed by Ferenczi and Vilma Kovács.

In 1925, István Hollós was fired from his position as head physician at the psychiatric hospital of Lipótmező because of his Jewish background. Two years later he published *My Farewell from the Yellow House*, in which he investigated psychosis from a new and innovative point of view.

In 1928, Géza Róheim traveled to central Australia, Normanby Island, and America. During his research, financed by Marie Bonaparte, he combined anthropological research with psychoanalytic theory.

In 1930, a psychoanalytic clinic for children was created under the direction of Margit Dubowitz. That same year Lilian Rotter and Fanny Hann joined the association. In 1931, in spite of several administrative problems, a polyclinic was opened at 12 Mészáros Street, with Ferenczi as director. The building and funding were provided by Vilma Kovács and her family; analysts from the association provided free consultations.

Ferenczi's students prepared *Psychoanalytic Studies* for his sixtieth birthday, but the book wasn't published until after his death in 1933. István Hollós then



became president of the association and Mihály Bálint director of the polyclinic.

In 1935 and 1937 two meetings, known as the Four Nations, were organized by the psychoanalytic associations of Vienna, Prague, Italy, and Hungary, the first in Vienna, the second in Budapest, and devoted to the problems of psychoanalytic training. At the second meeting, Vilma Kovács detailed the characteristics of the Hungarian method and Anna Freud read a paper by Helene Deutsch criticizing the method.

Hungarian analysts also began a program to develop public awareness of psychoanalysis. Kata Lévy organized seminars with teachers, Alice Bálint with mothers, and Mihály Bálint held discussion groups with general practitioners. In 1933, Lilly Hajdu, a psychiatrist, joined the association.

During the late thirties, threatened by the rise of anti-Semitism and fascism, a number of analysts decided to emigrate. Among them were the Bálints, Géza Róheim, Sándor Feldmann, and Edit Gyömrői. The association continued to function under police surveillance and under the direction of its non-Jewish members, Endre Almássy and Tibor Rajka. In 1944, when German troops invaded Hungary and put Hungarian Nazis in power, several analysts, including Zsigmond Pfeifer, Géza Dukes, László Révész, Miklós Gimes, and József Eisler, became victims of persecution. Imre Hermann and István Hollós barely escaped with their lives.

After 1945, psychoanalysts in Hungary resumed their activities. They participated in the creation of a mental health institute and worked in dispensaries. But the Stalinist government, which came to power in 1948, forced the association to dissolve. From then on psychoanalysis survived in a semi-clandestine fashion, primarily through the help of Imre Hermann, who trained the new generation of analysts: György Vikár, Livia Nemes, Agnes Binét, Teréz Virág. The dark years after 1956 were marked by the suicide of Lilly Hajdu, whose husband was murdered by the Nazis and whose son, a friend of Imre Nagy, had been executed along with the prime minister. During the sixties, the Kádár government became more tolerant of psychoanalysis. István Székács, a member of the Hungarian Psychoanalytic Association since 1939, also began to train psychoanalysts, although not initially a member of Hermann's group.

During the seventies, Hungarian analysts still did not have an officially recognized association, but some public manifestations of recognition took place. In 1969, for example, Imre Hermann was decorated on his eightieth birthday and, in 1974, a commemorative celebration was organized for the Ferenczi centenary. In 1987 an international congress of psychoanalysis was held in Budapest.

After democracy was restored in 1989, the Hungarian Psychoanalytic Association was reconstituted and affiliated itself with the International Psychoanalytic Association. A new generation of analysts was able to practice, teach, and publish openly.

The Ferenczi Society, a broad-based group of people interested in psychoanalysis, began to publish the review *Thalassa*. While the first generation of analysts trained by Imre Hermann was affected primarily by his ideas, contemporary psychoanalysts were reevaluating the ideas of Ferenczi, which they were forced to read in foreign editions since his complete works had not yet been published in Hungarian because of a lack of funding. They also served as an inspiration for Otto Kernberg.

Hungarian psychoanalysts of the 1930s developed a number of specific ideas that justify referring to them collectively as the Budapest School. These include the importance of trauma in the etiology of mental pathology, the attention given to object relations, consideration of dyadic relations and regression, and insistence on the importance of experience in therapy. Hungarian training methods differed from other methods in that the candidate's first control analysis was undertaken by his own analyst to further an understanding of the countertransference and better understand his own transference to the analyst.

Ferenczi's students demonstrated considerable creativity. Imre Hermann developed the theory of clinging, Géza Róheim the ontogenetic theory of culture, and Mihály Bálint the theory of primal love (and several others after his emigration). Lilian Rotter developed a body of original work on female sexuality and Alice Bálint on the mother-child relationship. István Hollós and Lilly Hajdu examined psychoses from a psychoanalytic point of view.

ÉVA BRABANT-GERŐ

### Bibliography

- Bálint, Michael. (1968). *The basic fault: Therapeutic aspects of regression*. London: Tavistock Publications.
- Brabant-Gerő, Éva. (1993). *Ferenczi et L'école hongroise de psychanalyse*. Paris: L'Harmattan.
- Ferenczi, Sandor. (1955). Selected Papers of Sandor Ferenczi. (Vol. 3, Michael Bálint, Ed.). New York: Basic Books.
- Haynal, André. (1988). *The technique at issue: Controversies in psychoanalysis from Freud and Ferenczi to Michael Bálint*. (Elizabeth Holder, Trans.). London: Karnac. (Original work published 1986)
- Hermann, Imre. (1972). *L'instinct filial*. (G. Kassai, Trans.). Paris: Denoël.
- Hungarian Psychoanalytic Association. (1933). *Lélekelemzési Tanulmányok* (Psychoanalytic Studies). Budapest: Somló.

## HYPERCATHESIS

Freud employed the term “hypercathesis” to designate an additional charge of instinctual energy cathecting any already cathected psychical element. The word’s primary application was in the description of the economy of consciousness, but it also served in connection with the regulation of the flow of psychical energy and the constitution of the preconscious realm.

The term was first used by Freud in the “Project for a Scientific Psychology” (1950c [1895]), where it referred to a mobile cathexis of the ego specific to consciousness, necessary to the mechanism of attention, and consisting in a supplementary cathexis of neurones already cathected by perception. In Freud’s account consciousness affected indications of quality. It arose from the excitation, during perception, of particular neurones belonging to the system W. Attention first addressed the indications of quality transmitted by these already cathected neurones, and then, via a facilitated pathway, focused on the perceptions themselves, which were thus hypercathected. “By this means [the ego] is led to cathect precisely the right perceptions or their environment” (p. 362). The ego was hence able to distinguish cathexes of real perceptions from cathexes of wishes, and the reality principle could be established.

According to Freud, the regulation of cathexes within the psychical apparatus remained unconscious,

and was effected automatically in accordance with the pleasure/unpleasure principle. In *The Interpretation of Dreams* (1900a), he pointed out that this initial mechanism was fine-tuned by virtue of a cathexis of attention, described as a “hypercathesis set up . . . by the regulating influence of the sense organ of the Cs.” (p. 617), which at times could even work counter to the primary mechanism by cathecting elements that were a source of unpleasure and that would otherwise succumb to repression.

In “The Unconscious” (1915e), Freud attributed the emergence of the preconscious to a hypercathesis of word-presentations by thing-presentations: “It is these hypercathexes, we may suppose, that bring about a higher psychical organization and make it possible for the primary process to be succeeded by the secondary process which is dominant in the Pcs. . . . A presentation which is not put into words, or a psychical act which is not hypercathected, remains thereafter in the Ucs. in a state of repression” (p. 202).

In considering the question of traumas, in *Beyond the Pleasure Principle* (1920g), Freud described the anti-traumatic regulatory function of hypercathectic energy, in the operation of the protective shield against stimuli, as the last line of defense in the attempt to bind the sum of excitation: “In the case of quite a number of traumas, the difference between systems that are unprepared and systems that are well prepared through being hypercathected may be a decisive factor in determining the outcome” (pp. 31–32).

RICHARD UHL

*See also:* Actual; Attention; Castration complex; Cathexis; Conscious processes; Consciousness; Disavowal; Facilitation; Idealization; Narcissistic defenses; Protective shield; Unconscious, the; Word-presentation.

### Bibliography

- Freud, Sigmund. (1900a). The interpretation of dreams. *SE*, 4–5.
- . (1915e). The unconscious. *SE*, 14: 159–204.
- . (1920g). Beyond the pleasure principle. *SE*, 18: 1–64.
- . (1950c [1895]). Project for a scientific psychology. *SE*, 1: 281–387.

## HYPNOID STATES

The notion of hypnoid states appeared in section 3 of “On the Psychical Mechanism of Hysterical Phenomena: Preliminary Communication,” published in January 1893 under the joint authorship of Sigmund Freud and Josef Breuer in preparation for their *Studies on Hysteria* of 1895. Hypnoid states involve a “splitting of consciousness” or “double conscience” (1893a, p. 12), in which ideas and affects are fragmented and then cut off from normal waking consciousness, but which, owing to what Freud a short time later called “false connections” (1895d, p. 302), can give way to new, pathogenic associations that engender hysterical symptoms.

The notion of hypnoid states originated from Freud and Breuer’s interest in hypnosis. Freud and Breuer wrote that they wanted to replace “the familiar thesis that hypnosis is an artificial hysteria by another—the basis and sine qua non of hysteria is the existence of hypnoid states” (1893a, p. 12). In themselves, such hypnoid states are not abnormal (as witness the daydreams “to which needlework and similar occupations render women especially prone” [p. 13]), but the hysteric is especially predisposed to them.

In fact, the notion of hypnoid states came from Breuer, who used it in a major explanatory principle in his account of the case of Anna O. and developed it in the fourth paragraph of the chapter on “theoretical considerations” that he wrote for *Studies on Hysteria*. By the time of that work, it is clear that Freud was only paying lip service to this idea as a concession to Breuer to obtain joint publication of their work. To be sure, Freud agreed that hysterical phenomena should be explained in terms of “dissociation” and a faulty recomposition, but unlike Breuer (who in this regard held views similar to those of Pierre Janet), he did not see in these phenomena a weakening of psychic functioning. On the contrary, he saw them as the mark of the active work of the defenses, above all repression. Freud later explained his stance on these issues, notably in “On the History of the Psycho-Analytic Movement” (1914d) and in “An Autobiographical Study” (1925d [1924]). Indeed, the notion of hypnoid states seems so contrary to metapsychology as a whole that it cannot be accepted as being a part of psychoanalysis.

ROGER PERRON

*See also:* Amnesia; Anna O., case of; Breuer, Josef; Dream; *Studies on Hysteria*; Hypnosis; Primary process/secondary process.

### Bibliography

- Freud, Sigmund. (1914d). On the history of the psychoanalytic movement. *SE*, 14: 1–66.
- . (1925d [1924]). An autobiographical study. *SE*, 20: 1–74.
- Freud, Sigmund, and Breuer, Josef. (1893a). On the psychical mechanism of hysterical phenomena: preliminary communication. *SE*, 2: 1–17.
- . (1895d). Studies on hysteria. *SE*, 2: 48–106.

## HYPNOSIS

Hypnosis is the altered state of consciousness brought on by a hypnotist using various techniques (staring at an object, verbal commands, etc.). The English physician James Braid, in his *Neurhypnology* (1843), popularized, or may even have coined, the word “hypnotism.” “Hypnosis” appears to have come into use later.

Braid sought to replace unscientific ideas and practices with a scientific conception of a “peculiar state of the nervous system induced by a fixed and abstracted attention of the mental and visual eye.” He also hoped to do away with what magnetizers called “rapport.” In the mid-nineteenth century, the English physiologist William Carpenter provided scientific support for “Braidism” by making hypnosis the paradigm of the reflexive and automatic activity that he called “unconscious cerebration.” Introduced to the topic by the young physiologist Charles Richet, Jean Martin Charcot experimented with hypnosis on hysterical patients in his clinic starting in 1878, basing himself on Braid’s and especially Carpenter’s neurological approach. In 1882, in an article that was noted by the Académie des Sciences, he identified a pathology unique to hysterics, the “grand hypnotism” characterized by three specific nervous states (catalepsy, lethargy, and somnambulism).

Starting in 1860 in Nancy, where he had set up a “clinic,” Ambroise Liebeault also made use of hypnosis, employing methods established by J.-P. Durand de Gros, one of the proponents of Braidism in France. He paid special attention to Braid’s experiments with suggestion, using hypnotic suggestion for therapeutic purposes, unlike Charcot, whose practice was almost

purely experimental. Hippolyte Bernheim went even further and treated hypnosis as a particular type of suggestion. He also popularized the term “psychotherapy,” which he borrowed from the Briton Hack Tuke, and practiced psychotherapy by means of suggestion with and without hypnotism. After 1884 two opposing schools of hypnosis developed around Charcot and Bernheim. In Paris, the emphasis was on the idea of a pathological nervous state; in Nancy, on that of a link or psychological influence that was not necessarily pathological.

Nonetheless, although they often took their cue from a particular school, some practitioners and researchers tried to look beyond prevailing theoretical and therapeutic dogmas. The psychotherapist could thus refuse merely to issue commands, and attempt through hypnosis, to discover memories forgotten during waking life that could be at the root of neurotic symptoms (see the case of Pierre Marie in *L'Automatisme psychologique* by Pierre Janet, 1889). Several stories of cures associated with the return of forgotten memories were published at the end of the nineteenth century.

In discussions of hypnotic suggestion the question of “rapport” was again raised. Joseph Delboeuf introduced the idea of reciprocal suggestion. Pierre Janet and Alfred Binet spoke of “electivity,” of “somnia-lant passion” and “experimental love.” Additionally, there was interest in the psychology of hypnotic states of consciousness. These were described in terms of dissociation (Janet) or hypnoid states (Sigmund Freud and Josef Breuer). Finally, contrary to the dominant medical view at the time, the idea arose that the unconscious was not only reflexological but psychological. Experiments with post-hypnotic suggestion, in which a subject, while awake, obeys an order given during a hypnosis that he has apparently forgotten, seemed to the philosopher Henri Bergson to prove the existence of unconscious ideas and a psychological unconscious. Freud the psychoanalyst undoubtedly emerged from this plethora of research and debate: 1885–1886 (Paris), 1889 (Nancy), and 1895 (publication of the *Studies on Hysteria*).

Hypnosis refers both to a state of consciousness (or unconsciousness) and to a relationship. True to the legacy of Charcot and Bernheim, present-day proponents of hypnology are still divided into “statists” and “relationists.” Some points of view, especially within the relationist school, draw on psychoanalysis, while

others seek to reinstate hypnotism as part of an anti-psychoanalytic tendency. For hypnosis, like animal magnetism before it, does not refer only to a state or to a relationship. Since the nineteenth century it has become a magical word with strong negative or positive connotations and as many staunch advocates as militant opponents—a tireless vector of fascination and stigma.

The practice, phenomenology, and theory of hypnosis have evolved, of course, since the time of James Braid, and hypnosis can now be seen as a largely cultural phenomenon. All the same, some questions, contradictory and probably unanswerable, seem to remain after more than a century. Is the hypnotic state akin to sleep and dreaming, or to wakefulness and lucidity? Does it imply an unconscious dispossession, or is it a form of playacting? And is “hypnosis” a functional concept that can explain certain phenomenon, or a word that precipitates the very state it is supposed to account for?

JACQUELINE CARROY

*See also:* Alienation; Anna O., case of; Autosuggestion; Bernheim, Hippolyte; Cécilie M., case of; Cathartic method; Charcot, Jean Martin; Chertok, Léon (Tchertok, Lejb); Cinema and psychoanalysis; “Confusion of Tongues between Adults and the Child”; Congrès international de l’hypnotisme expérimental et scientifique, Premier; Cure; Delboeuf, Joseph Rémi Léopold; Emmy von N., case of; *Five Lectures on Psycho-Analysis*; Freud’s Self-analysis; *Freud, the Secret Passion*; *Group Psychology and the Analysis of the Ego*; Hypnoid states; Janet Pierre; Liebault Ambroise Auguste; “Lines of Advance in Psycho-Analytic Therapy”; Look, gaze; Masochism; Negative hallucination; Psychoanalytic treatment; Psychotherapy; Relaxation psychotherapy; Repression, lifting of; Resistance; Self-consciousness; *Studies on Hysteria*; Suggestion; Trance; *Qu’est-ce que la suggestion?* (What is suggestion?).

### Bibliography

- Carroy, Jacqueline. (1991). *Hypnose, Suggestion et Psychologie: l’invention de sujets*. Paris: Presses Universitaires de France.
- Chertok, Léon, and Stengers, Isabelle. (1992). *A critique of psychoanalytic reason: Hypnosis as a scientific problem from Lavoisier to Lacan* (Martha Noel Evans in collaboration with the authors, Trans.). Palo Alto, CA: Stanford University Press. (Original work published 1989)

Ellenberger, Henri F. (1970). *The discovery of the unconscious: The history and evolution of dynamic psychiatry*. New York: Basic Books.

Freud, Sigmund. (1921c). Group psychology and the analysis of the ego. *SE*, 18: 65–143.

## HYPOCHONDRIA

Hypochondria is a psychopathological formation whose locus of suffering, anxiety, or even (fantasized) erasure is the body or one of its parts or functions, even though the symptoms in most cases appear to have no material cause. Symptoms can range from minor, transient forms to massive, debilitating forms. Despite some strong lines of evidence pointing toward a link with various specific structural organizations of the psyche, hypochondria is currently seen as transnosographic, as present as an element in a neuropsychosis or preceding certain psychoses.

For centuries, hypochondria has challenged medicine, philosophy, and even religion. Some ancient lines of inquiry are echoed by modern investigations, notably on the enigmatic link between psyche and soma and on similarities between hypochondria and melancholia. The absence of any material organic cause has elicited a variety of hypotheses from psychoanalysts, including accounts of pathogenicity that extend to delusions in the subject.

Has the enigma of hypochondria been fully deciphered by contemporary psychoanalysis? Freud acknowledged this poorly understood disorder as an awkward gap in his theories. Later it was deemed surprising that hypochondriacs had been the object of so little psychoanalytic research, but in the 1990s there were a number of studies on the topic. One reason that psychoanalysis has paid little attention to hypochondria is that the autocratic attitude of hypochondriacs has made analysts unreceptive to types of transference uncondusive to analytic listening. However, a broadening of treatment indications seems to have made psychoanalysis more receptive to hypochondriacs, and this has allowed psychoanalysis to draw conclusions from them that go beyond Freud's hypotheses. It is also true that hypochondriacal behavior can emerge in the course of any treatment, as a displacement or means of discharge when the patient's psyche is placed under stress.

Freud encountered hypochondria early on in his work. On the basis of the semantics and nosology of his era as well as his own theories, he placed hypochondria among the pure forms of "actual neurosis," alongside neurasthenia and anxiety neurosis, and thus outside of the realm of the defensive neuropsychoses. His description of the actual neuroses contains the same elements as hypochondria: the patient's representational contents have a basis in current reality and not in what has been repressed into the unconscious; the patient's meaningful contents or unconscious overdeterminations capable of being symbolized do not indicate an internal conflict with current reality.

In "On Narcissism: An Introduction" (1914c), Freud revised his account of hypochondria in light of his theory that the libido is divided into the object-libido and the (narcissistic) ego-libido. He placed (bodily) ego-libido, the realm of hypochondriacal anxiety, in opposition to object libido, the realm of neurotic anxiety. As a function of this opposition, the more one realm absorbs, the more the other is impoverished. Therefore, the idea of excessive, dammed-up narcissistic libido is essential to understanding hypochondria. The chosen organ of hypochondria, which has strong erotogenic potential, is nevertheless a source of unpleasure, suffering, and anxiety owing to this increase in tension, this damming up of libido. Many authors have viewed this account, a schematic model of dynamic energies, as problematic and fraught with questions.

During the same period, Freud tried to understand the possible relationship between hypochondria and paraphrenia. In "On Narcissism: An Introduction" (1914c) he wrote, "We may suspect that the relation of hypochondria to paraphrenia is similar to that of the other 'actual' neuroses to hysteria and obsessional neurosis: we may suspect, that is, that it is dependent on ego-libido just as the others are on object-libido, and that hypochondriacal anxiety is the counterpart, as coming from ego-libido, to neurotic anxiety" (p. 84). In this perspective he viewed hypochondria as the first stage in delusion and linked it to narcissistic pathologies affecting the body. Three years earlier he wondered about the connections between hypochondria and paranoia. For example, in "Psycho-Analytic Notes on an Autobiographical Account of a Case of Paranoia (*Dementia Paranoides*)" (1911c [1910]), his text on Daniel Paul Schreber, he wrote, "I shall not consider any theory of paranoia trustworthy unless it

also covers the *hypochondriacal* symptoms by which that disorder is almost invariably accompanied” (pp. 56–57, n. 3). Freud thus viewed hypochondria as a precursor to psychosis and sometimes as an independent condition.

Some authors have interpreted hypochondria in terms of true projections that are no longer directed outward but instead are directed at the body, like an internal paranoia. In his subsequent writings Freud did not return to the comparison with melancholia, nor did he reexamine his hypotheses in light of his second theory of the instincts or in terms of the concept of primary masochism, as later authors did, thereby somewhat undermining Freud’s classification of hypochondria as an actual neurosis.

Many others, notably followers of Melanie Klein, have emphasized the close relationship between hypochondria and melancholic depression. Others have inferred a masochistic dimension or a “locked-up” autoerotism. In the view of still others, the “hypochondriacal solution,” despite its fragile and largely unstructured nature and despite being pregnant with the death instinct, is the subject’s last bastion against madness.

ALAIN FINE

*See also:* Actual neurosis/defense neurosis; Body image; Eroticism, anal; Erotogenic zone; Erotogenicity; “On Narcissism: An Introduction”; “Neurasthenia and Anxiety Neurosis”; Organ pleasure; Persecution; Psychoanalytical nosography.

### Bibliography

- Aisenstein, Marilia; Fine, Alain; & Pragier, Georges (Eds.). (1995). *L’hypochondrie*. Paris: Presses universitaires de France.
- Freud, Sigmund. (1898a). Sexuality in the aetiology of the neuroses. *SE*, 3: 259–285.
- . (1911c [1910]). Psycho-analytic notes on an autobiographical account of a case of paranoia (*dementia paranoïdes*). *SE*, 12: 1–82.
- . (1914c). On narcissism: An introduction. *SE*, 14: 67–102.
- Jeanneau, Augustin. (1990). L’hypochondrie, ou La mentalisation de l’impossible. *Cahiers du Centre pour la psychanalyse et la psychothérapie*, 21, 83–99.

- Perrier, François. (1994). *Psychanalyse de l’hypochondriaque*. In Jacques Sédot (Ed.), *La Chaussée d’Antin* (rev. ed.). Paris: Albin Michel. (Originally published 1959)

### Further Reading

- Rosenfeld, Herbert. (1958). Observations on the psychopathology of hypochondriacal states. *International Journal of Psychoanalysis*, 39, 121–124.
- Stolorow, Robert D. (1977). Notes on the signal function of hypochondriacal anxiety. *International Journal of Psychoanalysis*, 58, 245–246.

## HYPOCRITICAL DREAM

A hypocritical dream is one that in which the dream’s wish is distorted (most often by the reversal of affect) such that it cannot be discerned in the manifest dream thoughts. Thus the wish is expressed “hypocritically,” in disguise.

Freud referred to hypocritical dreams in several passages of *The Interpretation of Dreams* (1900a). He first used the term in connection with a dream in which he felt a great affection towards his friend R. But the analysis of the dream showed that in fact the latent wish was to portray R. as a simpleton (1900a, pp. 137 ff.). Freud also referred to a dream about a reconciliation with a friend in which the latent wish was to free himself from this friend completely (p. 145n.). He returned to the topic later in the book, writing that “There is one class of dreams which have a particular claim to be described as ‘hypocritical’ and which offer a hard test to the theory of wish-fulfillment” (p. 473). Witness the repetitive dream of the poet Rosegger in which he found himself each night back in the unfortunate situation of a apprentice tailor ill-suited for his craft (pp. 473–75).

Freud referred to a similar dream of his own in which he found himself back in a laboratory where he had once worked in his younger days, ill-suited to the chemical analyses he was required to perform. This was, Freud says, a “punishment dream” (p. 476) that followed upon his daytime thoughts of being too proud of the success of his psychoanalyses. Such a punishment dream, he goes on, is nothing but the inverted expression of a wish. He modified this theory considerably in his theoretical revisions of the twenties (1920g, 1923b, 1924c). And the question of hypocriti-

cal dreams was, for Freud, closely linked to that of repetitive dreams.

The term “hypocritical dream” is not frequently used in present-day psychoanalysis. However, the question that Freud posed under this rubric remains essential: Is every dream the realization of a wish?

ROGER PERRON

*See also:* Dream.

### **Bibliography**

- Freud, Sigmund. (1900a). The interpretation of dreams. *SE*, 4–5.
- . (1920g). Beyond the pleasure principle. *SE*, 18: 1–64.
- . (1923b). The ego and the id. *SE*, 19: 1–66.
- . (1924c). The economic problem of masochism. *SE*, 19: 155–170.

## **HYSTERIA**

*Hysteria* refers both to a personality type and to a cluster of psychoneurotic symptom formations. Its manifestations—dramatic, physical, and affective—may be viewed as an attempt to express and symbolize a psychosexual conflict and, at the same time, to defend against acknowledging that conflict. Symptoms range from mental anxiety and phobia to the physical signs of conversion disorder.

The term derives from *hysteria*, the Greek word for uterus, and was historically considered a female disorder. Writings on hysteria date to ancient Egypt and the Kahun papyrus (ca.1900 BCE), which described the disturbances caused by the “wandering uterus” that manifested as symptoms in various parts of the body. Greco-Roman doctors continued to associate hysteria with the uterus and to treat it as a female complaint. From the end of antiquity through the Middle Ages and the Inquisition, recourse to supernatural explanations made it possible to consider hysteria a form of demoniacal possession or witchcraft. The theatrical and contagious nature of hysterical symptoms may have been at the root of phenomena such as the “possessed” nuns of Loudun, the convulsionaries of Saint-Médard, and the Salem witches. Hysterics and their putative victims were often burned at the stake.

Identification of hysteria as a distinct entity dates to 1870, when Jean Martin Charcot, a doctor at the largest hospice in France, the La Salpêtrière, segregated hysterics from other mental patients for purposes of research and investigation.

As a concept hysteria acquired several meanings:

1. Conversion hysteria was a convulsive attack characterized by paralysis, muscular contractions and bodily contortions, visual disturbances, including hallucination, pain and anesthesia, and so on.
2. As a psychoneurosis, studied by psychoanalysis, it was manifested by various symptoms and inversion of affect. Thus, Sigmund Freud's patient Dora experienced sexual excitation not as desire but as disgust, a hysterical displacement of a genital sexual conflict (1905e).
3. The term “hysteric” also qualifies, pejoratively, a certain type of distaff personality in which prominent use is made of dramatization, emotional exuberance, colorful and exaggerated language, continuous erotization, and seductiveness.
4. Finally, in everyday language, hysteria is the stuff of “emotional outburst” and “making a scene.”

Broadly speaking, conversion hysteria led to the discovery of psychoanalysis as a method of understanding and treating psychopathological symptoms. Freud, who famously attended clinical demonstrations by Charcot, was struck by the indifference that hysterical patients displayed toward their suffering. Although for a time he suspected traumatic childhood seduction to be at the root of hysteria, he came to view such patients suffering “mainly from reminiscences” (1895d, p. 7)—that is, from a repressed traumatic event that remained mnemonically unintegrated, and could therefore only be expressed by conversion—through a corporeal memory, so to speak.

The death of his father in 1897 and subsequent self-analysis with Wilhelm Fliess led Freud to the discovery of his childhood passion for his mother and of his hostile feelings toward his father. Although the Oedipus complex did not appear as part of Freudian theory until later, he abandoned the theory of traumatic seduction; his key discovery was the notion of infantile sexuality, together with the importance of fantasy as a force that was both creative and disorganizing. At the same time he developed the concept of psychic defense

and discovered in dreams and dream-work a link with hysteria.

In psychoanalytic theory, a hysterical crisis might be thought of as the embodiment of a dream. Its symptoms included the same mechanisms of condensation, displacement, symbolization, and disguise through censorship. Hysteria expressed a conflict that, incapable of being elaborated mentally, is translated in altogether enigmatic fashion into physical symptoms. The associative method of psychoanalysis could be used to identify the fantasies and symbolic pathways within it. Thus Freud described a hysterical woman who, with one hand, tore off her clothes, and with the other, held them against her body, simultaneously expressing the struggle between impulse and defense, enacting in effect a sexual scene in which she represented partners of both sexes (1908a). Hysterical neurosis and hysterical relationships involve identification, constant repression, and counter-cathexis that uses the Other as the theater of conflict.

Due to the absence of an organic lesion and the tendency for symptoms to disappear without a trace, as mysteriously as they came, hysterical conversion represented a provocative challenge to medicine. In general, hysterics have historically triggered irritation, accusations of lying and malingering, and rejection.

Hysteria has always defied medicine and the social order because sexuality is mixed up in it—in particular, female sexuality and the associated desire for sexual pleasure. Freud, in 1937, referred to the “repudiation of femininity” (p. 252) in both sexes as “bedrock,” a stumbling block because of the mental association of the female with castration. Symptomatically, hysteria is an illness of repudiated femininity. More specifically, the anxiety that leads to this repudiation reflects the considerable libidinal energy required by the constant pressure of libido, a pressure that may be destructive of the ego.

JACQUELINE SCHAEFFER

*See also:* Activity/passivity; Actual neurosis/defense neurosis; Anna O., case of; Anxiety; Archeology, the metaphor of; Autoplastic; Autosuggestion; Breuer, Josef; Cécilie M., case of; Charcot, Jean Martin; “Claims of Psychoanalysis to Scientific Interest”; Conflict; Defense mechanisms; “Dostoyevsky and Parricide”; Elisabeth von R., case of; Emmy von N., case of; Fantasy; Femininity; *Five Lectures on Psycho-Analysis*; “Fragment of an Analysis of a Case of Hysteria” (Dora, Ida Bauer); *Freud, the Secret Passion*; Fright; Hypnoid states; Hysterical

paralysis; Indications and contraindications for psychoanalysis in adults; Janet, Pierre; Katharina, case of; Lifting of amnesia; Lucy R., case of; Mnemic symbol; Mnemic trace, memory trace; *Nervous Anxiety States and their Treatment*; Neurosis; Phobias in children; Phobic neurosis; Proton-pseudos; Psychoanalytical nosography; Psychogenic blindness; Psychological types (analytical psychology); Quota of affect; Reminiscence; Repression; Seduction; Seduction scenes; Sexual trauma; Somatic compliance; *Studies on Hysteria*; Symbol; Symptom-formation.

### Bibliography

- Freud, Sigmund. (1937). Analysis terminable and interminable. *SE*, 23: 209–253.
- Freud, Sigmund, and Breuer, Josef. (1895d). Studies in hysteria. *SE*, 2.
- Jeanneau, Augustin. (1985). L'hystérie, unité et diversité. *Revue française de psychanalyse*, 49 (1), 258–283.
- Schaeffer, Jacqueline. (1986). Le rubis a horreur du rouge. Relation et contre-investissement hystériques. *Revue française de psychanalyse*, 50 (3), 923–944.
- . (1997). *Le refus du féminine*. Paris: Presses Universitaires de France.

### Further Reading

- Britton, Ronald. (1999). Getting in on the act: The hysterical solution. *International Journal of Psychoanalysis*, 80, 1–14.
- Halberstadt-Freud, Hendrika. (1996). Studies on hysteria one hundred years on: a century of psychoanalysis. *International Journal of Psychoanalysis*, 77, 983–996.
- Kohon, Gregory. (1984). Reflections on Dora: The case of hysteria. *International Journal of Psychoanalysis*, 5, 73–84.

## HYSTERICAL PARALYSIS

*Hysterical paralysis* designates various forms of loss of mobility of the upper or lower limbs that are present in certain patients without any indication of a direct neurological cause.

Even before the *Studies on Hysteria* (1895d), the problems that hysterical paralysis posed for the medical diagnostic model led Freud to introduce the first elements of psychoanalysis in a work called, “Some Points for a Comparative Study of Organic and Hysterical Motor Paralysis” (1893c).

To Freud, hysterical paralysis seemed too precisely delimited in relation to their “excessive intensity”



(1893c, p. 164), and they appeared to be related more to the way patients imagined their bodies than to any distribution of lesions in real anatomy. Based as it was on the fact that peripheral points on the body are grouped at the level of the nerves that represent the medullary centers of the cortex, Freud's neurological conception of "representation paralysis" went far beyond what Charcot himself (1880–1893) called a "disease of representation." Freud was in effect seeking "permission to move on to psychological ground" (1893c, p. 170), and he crossed that border on the basis of the difference between organ and function.

This amounted also to placing paralysis on the level representing both fantasy and action. By defining the hysterical paralysis of the arm as "the abolition of the associative accessibility of the conception of the arm" (1893c, p. 170), he raised both the question of trauma and that of the affective value of a function, so anticipating what would later be known as associative links and breaks, isolation and repression.

We see here too that what would later become the "innervation" of the repressed idea—"psychical excitation that takes a wrong path," as Freud wrote in 1894 (1950a, p. 195)—did not restrict the notion of conversion to a single idea of discharge, but installed it within conflictual ambivalence, and this whether it was muscular contraction, paralysis, or anesthesia that was at issue. Thus the symptom achieves the repression of the representation and the return of the related affect to its original innocent status as action. This disconnection between affect and symptom is what Charcot referred to as the "*belle indifférence*" of hysterics (cf. Freud, 1915d, pp. 155–56).

Thus conversion holds a precise position between hypochondria, which seeks to mentalize the unrepresentable depths of the body's interior, and, at the other extreme, psychosomatic disturbances where improvement or somatic recovery dispense with the symbolic level entirely. Between the two, conversion involves the striated musculature in order to play out a drama at the level closest to the body. The involvement of the vegetative level is not excluded here, so long as it is introduced into a fantasy, the desire of which was expressed in its negative form as a paralysis (Jeanneau, 1985).

AUGUSTIN JEANNEAU

*See also:* Charcot, Jean Martin; Conversion; Elisabeth von R., case of; Hysteria; Innervation; Psychic causality; Psychic reality; Psychotic/neurotic; Somatic compliance; *Studies on Hysteria*; Symptom-formation.

### **Bibliography**

- Freud, Sigmund. (1950a). Extracts from the Fliess papers. *SE*, 1: 173–280.
- . (1915d). Repression. *SE*, 14: 141–158.
- . (1893c). Some points for a comparative study of organic and hysterical motor paralyzes. *SE* 1: 155–172.
- Freud, Sigmund and Breuer, Josef. (1895d). *Studies on Hysteria*. *SE*, 2: 48–106.
- Jeanneau, Augustin. (1985). L'hystérie, unité et diversité. *Revue française de psychanalyse*, 49 (1), 258–283.

The concept of the “I” appears in Jacques Lacan’s work as a function that derives from the mirror stage. Piera Aulagnier later develops this term in a different way and defines it as nothing other than a knowledge of itself: “the I is nothing more than the I’s knowledge of the I” (1975/2001, p.114).

Despite their semantic proximity, the I, for both Lacan and Aulagnier, is something clearly distinct from the Freudian ego; the latter is an agency, even if it claims to represent the totality of the person, and it has to be understood in relation to the other agencies (id, superego) and to the demands of reality and the object, which it can also oppose by occupying its position and turning, narcissistically, to the love of the id.

Towards the end of his work (1923b), Freud ascribes a different origin to the ego, no longer considering it as a psychic agency or no longer defining its “character” only as a product of identifications but regarding it as “the mental projection of the surface of the body” and thus primarily as a “bodily ego” that is derived from sensations.

Jacques Lacan introduced the concept of “I” with the mirror stage (1936, then 1949), in opposition not to the Freudian ego but to the philosophy derived from the Cartesian *cogito*. The mirror stage constitutes an identification; namely, the transformation that occurs in a subject when he assumes an image as his own. This stage constitutes a fundamental identification that precedes the moment when the subject identifies with others through the mediation of language. It comprises several phases: in the first, the child reacts

joyfully to the image but identifies it as belonging to an other; in the second, he perceives its imaginary nature and seeks the other behind the mirror; in the third, the child recognizes the image as his own. For Lacan, this entails the progressive and structuring conquest of the I through the intermediary of the subject’s own body. “This *Gestalt*... symbolizes the mental permanence of the *I* at the same time as it prefigures its alienating destination; it is still pregnant with the correspondences that unite the *I* with the statue in which man projects himself, with the phantoms that dominate him, or with the automaton in which, in an ambiguous relation, the world of his own making tends to find completion” (1949/2002, p. 3]). Therefore the *I* simultaneously is alienated in this image, because it is always external to it, and finds a stability, if not a permanence, there. Here Lacan adduces the concept of alienation: “[the subject] identifies his sense of self with the image of the other and the image of the other then captivates this sense in him” (1946–50). In a second temporal phase, the subject is mediated by language, thereby returning to the unconscious everything that does not pass into discourse.

Piera Aulagnier fundamentally modifies the Lacanian concept of I by historicizing it, that is, by defining it in terms of the dual processes of “self-historicization” and the “identificatory project.” However, it is principally in the mother-child relationship, well before the mirror stage, that she locates the primary identification from which the I will subsequently emerge. For the child, this identification develops from the first experience of pleasure, and it is the mother who identifies the child as the seeker of what she is offering, which thus makes him dependent on her own imagination. Similarly, in the mirror stage,

Aulagnier emphasizes that the child, having recognized the specular image as his own, turns to his mother to seek approbation in her gaze and thus to find the “junction between the image and the legend” (1975/2001, p. 124). “She alone will be able to complete the narcissistic image, to add that ‘something more’ that is indispensable to its sheen and without which it would cease to be anything more than it is in the real: an effect of the laws of optics” (1975).

For Aulagnier, however, the I is not to be confused with the precursor of the I that is constituted by the subject’s representational activity in these early stages. The I is first of all anticipated by the mother (as “word-bearer”) and as this still-idealized I that is formed during the “representative” stage, that is to say the child’s psyche that represents itself as possessing an absolute and immediate power over reality.

How does the I come into being? It is through the act of enunciation, but rather than just any act, it is that which names the affect: “*the act of uttering a feeling is therefore at the same time the utterance of a self-naming by the I*” (p. 97). To name the other with the term of beloved, for example, is to designate the subject who is naming as that of the lover. Hence the author’s formulation: “It is therefore in and by the deferred action of naming the cathected object [affect and kinship system] that the I comes about . . . the I is nothing more than the knowledge that the I may have of the I” (p. 98).

This knowledge has a sole purpose: to guarantee to the I a knowledge of its past and its future, the former being the precondition for the representability of the latter. The I will be characterized by its work, which differs from the enacting fantasy because it entails a work of making-sense based on “ideational representations.” Despite being anticipated by the mother at a primitive stage, the I can subsequently occur only by itself. The Other, the mother, no longer has the power to respond to questions such as “who am I?” or “what am I to become?”: “To these two questions, which must necessarily find an answer, the I will respond on its own behalf by the continuous self-construction of an ideal image that it claims as its inalienable right and which assures it that the future will prove to be neither the result of pure chance, nor forged by the exclusive desire of another I” (p. 116).

What is possessed in this case is nothing but an outline, but what is cathected is the ideal image, as well as

the ability to construct it and to recognize oneself through this process of construction. No philosophical observation about freedom can be dissociated from this definition of the I, as the author establishes it on the basis of the preconditions for the emergence of the I, and the way in which these preconditions can be lacking in the case of psychosis.

SOPHIE DE MIJOLLA-MELLOR

*See also:* Alienation; *Apprenti-historien et le maître-sorcier (L’-)* [The apprentice historian and the master sorcerer]; Aulagnier-Spairani, Piera, ex-Castoriadis-Aulagnier; Demand; Ego; Ego (ego psychology); Encounter; Graph of Desire; Ideational representation; Identificatory project; Individual; Individuation (analytical psychology); Infant observation; Infantile psychosis; Integration; Need for causality; Object; Other, The; Passion; Primal, the; Psychic temporality; Psychoanalytic treatment; Psychotic potential; Sartre and psychoanalysis; Self-consciousness; Self-image; Sense/nonsense; Subject; Subject of the drive; Truth; *Violence of Interpretation, The: From Pictogram to Statement*.

### Bibliography

- Castoriadis-Aulagnier, Piera. (2001). *The violence of interpretation. From pictogram to statement*. (Alan Sheridan, Trans.) Hove: Brunner-Routledge. (Original work published 1975)
- Charron, Gyslain. (1993). *Le discours et le Je*. Klincksieck, Canada: Presses de l’université de Laval.
- Lacan, Jacques. (2002). *Écrits: A selection*. (Bruce Fink, Trans.) London: Tavistock Publications.
- Mijolla-Mellor, Sophie. de (1998). *Penser la psychose. Une lecture de l’œuvre de Piera Aulagnier*. Paris: Dunod.

## ID

Linked with the ego and the superego, the id (*das Es*) is the mental agency, in Freud’s “second topography” of 1923, that answers to the instincts and to the greater part of the unconscious processes. In German, *es* is the neuter personal pronoun. Its use as a noun, with an initial capital—*das Es*—is perfectly regular. From the standpoint of linguistics, *es* presents problems at the border between semantics and the syntax of anaphora: in order to understand what it signifies one must refer to another part of the discourse that interprets it. Thus *es* may be interpreted as any neuter noun in German and is also used, like the English “it,” in many

impersonal constructions. Syntactically, *es* may be the subject or object of transitive verbs. Consequently, an idea designated “*das Es*” is liable to be indefinite and impersonal, universal, diverse, ambiguous and equivocal, even contradictory.

Georg Groddeck used this term to refer to the universal unconscious agency—as force and as substance—that he considered to be his interlocutor and object of study when he treated patients suffering from somatic illnesses: “There is something common to the body and the soul; there is an Id in them, a force by which we are lived, even as we believe we are living ourselves” (Groddeck to Freud, May 27, 1917). Groddeck borrowed the term from the Berlin physician Ernst Schwenger, who had written, “The id cures.” The idea of an energetic monism was in any case a commonplace of the German culture of the time. And of course Groddeck had been reading Freud in the 1913–1917 period.

Freud first encountered the notion of the id in Groddeck’s letter. His response in a letter of June 5, 1917, was critical: “The notion of the *Ucs* requires *no extension*.” The *Ucs* (unconscious) system was adequate for dealing with organic illnesses, for it influenced somatic processes. And why “cancel the difference between psychological and physical phenomena”? “I am afraid,” Freud concluded, “that you are a philosopher as well and have the monistic tendency to disparage all the beautiful differences in nature in favor of a tempting unity” (1960a, pp. 317–318). But in the same letter Freud had dubbed Groddeck “an analyst of the first order,” and subsequently he supported him, having his *Book of the It* published by the International Psychoanalytischer Verlag just before his own *The Ego and the Id*. Apropos of *The Book of the It*, he wrote to Groddeck on March 25, 1923 that “The work . . . expounds the theoretically important point of view which I have covered in my forthcoming *The Ego and the Id*” (1960a, p. 342).

The Freudian conception of the id, which he worked out in the summer of 1922, was presented in *The Ego and the Id*. That work, along with *Beyond the Pleasure Principle* and *Group Psychology and the Analysis of the Ego*, constituted what Freud called “the third step in the theory of the instincts” (1920g, p. 59). The life and death instincts (*Pleasure Principle*) opened up a dynamic space for the accommodation and study, in *Group Psychology*, of the large-scale mental formations of the “second step”: ego, ego ideal, identifications. In

*The Ego and the Id*, moving “closer to psycho-analysis” (1923b, p. 12), Freud confronted the ego and its unconscious resistance on the one hand and the unconscious/preconscious-conscious (*Ucs./Pcs.-Cs.*) distinction on the other. As a result, this last system was now seen as local, confined to the superficial layers of the mental apparatus where the *Ucs.* was synonymous with the repressed; it was unable to explain the resistance of the ego and inadequate as far as practice was concerned. In order to take the ego into account it was now necessary to move from the “local” examination of the symptoms and their treatment to a global view of the mental personality and of psychoanalytical treatment. This shift of level implied different dynamics and forms, although it did not necessarily mean that local forms and dynamics were surpassed or modified.

Freud introduced the id as alien to the ego, as “the other part of the mind,” global and unconscious, incorporating the repressed and the forces by which (in Groddeck’s terms) we “are lived”: a realm large enough to be that which the ego resists (1923b, p. 23). “We shall now look upon an individual as a psychical id, unknown and unconscious, upon whose surface rests the ego, developed from its nucleus the *Pcpt.* [perceptual] system.” (p. 24). The resistance of the ego was not identical to the familiar local resistances, for it had a global aspect that it manifested in the treatment (often after the local symptomatic features had been worked on) precisely at the point where it was confronted by something alien to it. The inadequacy of the *Ucs./Pcs.-Cs.* opposition was thus bound up with the countertransference and with the orientation of the treatment, issues that could not be addressed solely in terms of the first topographical theory.

The introduction of the notion of the id bespoke a fresh overall approach on Freud’s part to treatment and the mental personality. Because of the life and death instincts, it was possible to claim a place for this new point of view “in the structure of science” (1923b, p. 23) without falling into monism. The attribution of the id’s paternity to Nietzsche, inaccurate on its face, perhaps may be taken as a semantic reference to the philosopher who, in criticizing philosophies of consciousness and of the subject, did the most to thematize the dynamics of the psyche.

The division of the mental personality into three provinces, id, ego, and superego, would not have been relevant had each of the three agencies not been

characterized by Freud, beginning in *The Ego and the Id*, by sufficient ambiguity, diversity, and even contradiction. Since he did, the concept of the id would remain stable until the end of his work. A main interpretant of the id is instinctual life. “We approach the id with analogies: we call it a chaos, a cauldron full of seething excitations. We picture it as being open at its end to somatic influences, and as there taking up into itself instinctual needs which find their psychical expression in it, but we cannot say in what substratum.” (1933a [1932], p. 73). Since psychoanalysis is a dynamic theory of the psyche, the “whole person” is an interpretant of the id (p. 105), and psychoanalysis is “a psychology of the id (and of its effects on the ego)” (1924f, p. 209). The prevalence of the dynamic aspect means that the ego and the superego emerge from the id as “superficial strata” differentiated during ontogenesis; “id and ego are originally one” (1937c, p. 240); the superego “is in fact a precipitate of the first object-cathexes of the id” (1926e, p. 223). So the ego and the superego are interpretants of the id. (In *The Ego and the Id*, “es” is related to ego and superego in an ambiguous manner.)

External reality is not an interpretant of the id (since we are not dealing here with the instinctual point of view), but it does illuminate the dominance of the pleasure principle in the id. The id knows nothing of logic, nothing of negation; contrary instinctual impulses coexist within it; the mechanisms of displacement and condensation are normal; dispersal and disorganization reign. And if, “in its blind efforts for the satisfaction of its instincts, it disregarded that supreme external power,” the outside world, if it did not have the ego as its protective shield and guide vis-à-vis reality, then the id, motor of the psyche, “could not escape destruction” (1933a [1932], p. 75).

The id is not only a motor—it is also the locus of the motor; and in this respect, passive—it is a reservoir, or a storehouse (in which case reality is indeed an interpretant of the id). The id is the original reservoir of libido and of the destructive instincts that cathect and nourish the ego and the superego and their cathexes; it is also a storehouse for active memory-traces and, in this capacity, indifferent to time: “Wishful impulses which have never passed beyond the id, but impressions, too, which have been sunk into the id by repression, are virtually immortal.” (1933a [1932], p. 74). The id embraces the repressed, and by extension the unconscious: “The impressions of early traumas

... are either not translated into the preconscious or are quickly put back by repression into the id-condition. Their mnemonic residues are in that case unconscious and operate from the id” (1939a, pp. 97–98). The id also stores up human history: “The experiences of the ego seem at first to be lost for inheritance; but, when they have been repeated often enough and with sufficient strength in many individuals in successive generations, they transform themselves, so to say, into experiences of the id, the impressions of which are preserved by heredity. Thus in the id, which is capable of being inherited, are harboured residues of the existences of countless egos; and, when the ego forms its super-ego out of the id, it may perhaps only be reviving shapes of former egos and be bringing them to resurrection” (1923b, p. 38). Such an archaic inheritance may include symbolism, the schemata of primal fantasies, or memory-traces of the killing of the primal father by the primal horde (1939a, pp. 98–101).

Although the id-ego-superego system entails not only conflicts between these agencies but also intra-agency conflict, there is no conflict within the id. Clinical experience allows for part of the id’s operations to be inferred. The repressed is transformed there; the id can destroy a repressed impulse, the libido of which is diverted into other channels. The liquidation of the Oedipus complex, which is not repression but rather destruction in the id, is an example. A regression of the libidinal organization can be brought about by the id, as for example in compulsive neurosis.

Since psychoanalysis is an interpretant of the id, any notion may be related to it. Furthermore, the id is neither separated nor separable from the areas onto which it opens: the somatic realm, the ego and superego, even external reality; from its dynamic dimension, where the life and death instincts are to be found; from its constituent elements: instinctual life, libido, hate, repressed material, memory-traces, the unconscious; or from the pleasure principle.

The articulation of the mental personality in accordance with the ego-superego-id scheme revived discussion on the following issues: the distinction between neurosis and psychosis; the classification of individuals into “libidinal types” defined by the particular conflicts that predominate in each case between id, ego, superego, and reality; and the forms of resistance and the dynamics of working-through: Freud describes as “arising from the id” the form of resis-

tance that, even after ego-resistances have been relaxed, demands a “period of strenuous effort” in order to undo repressions (1926d, pp. 160, 159).

The conduct and aims of analysis were described by Freud as follows: “During the treatment our therapeutic work is constantly swinging backwards and forwards like a pendulum between a piece of id-analysis and a piece of ego-analysis. In the one case we want to make something from the id conscious, in the other we want to correct something in the ego. . . . The therapeutic effect depends on making conscious what is repressed, in the widest sense of the word, in the id.” (1937c, p. 238). “Its intention is, indeed, to strengthen the ego, to make it more independent of the superego, to widen its field of perception and enlarge its organization, so that it can appropriate fresh portions of the id. Where id was, there ego shall be. It is a work of culture—not unlike the draining of the *Zuider Zee*” (1933a, p. 80).

Lastly, the question of anxiety was modified by the advent of the division into id, ego, superego, and reality. Whereas anxiety had hitherto been seen as arising from repressions, it was now acknowledged as intrinsic to the psyche and indeed as a factor in the institution of these divisions: “. . . the expression ‘anxiety of the id’ would stand in need of correction, though rather as to its form than its substance. . . . The id cannot have anxiety as the ego can; for it is not an organization and cannot make a judgement about situations of danger. On the other hand it very often happens that that processes take place or begin to take place in the id which cause the ego to produce anxiety. Indeed, it is probable that the earliest repressions as well as most of the later ones are motivated by an ego-anxiety of this sort in regard to particular processes in the id” (1926d, p. 141). Freud distinguishes two cases: something in the id may activate a danger-situation for the ego and spark anxiety in it; alternatively, “a situation analogous to the trauma of birth is established in the id and an automatic reaction of anxiety ensues” (1926d, pp. 140–41).

“But one cannot flee from oneself; flight is no help against internal dangers. And for that reason the defensive mechanisms of the ego are condemned to falsify one’s internal perception and to give one only an imperfect and distorted picture of one’s id” (1937c, p. 237). Depending on the epistemology to which one subscribes (and on the resistance by which this choice is motivated), one will be more or less inclined to

accept the aspects of the unknown and the possible that Freud introduced into the metapsychological realm along with the id; these aspects are correlated with intrinsic and universal psychic dynamics and cannot be reconciled with positivism, pragmatism, or structuralism. In the history of psychoanalysis, what Freud had called “the third step in the theory of the instincts” came, after him, to be known as the “second topography.”

After Freud, the dynamic dimension of the id and the importance of the instincts were concealed rather than further developed by a good many psychoanalytic tendencies. The ego psychology of Heinz Hartmann and his followers, the emphasis on object relationships (Ronald Fairbairn or Michael Balint in Great Britain, Margaret Mahler and Otto Kernberg in the United States), the foregrounding of the Self (Donald Winnicott, Heinz Kohut)—all either play down the notion of instinct (or drive) to the benefit of the object or sideline it completely; in all cases the id no longer has any *raison d’être*. Jacques Lacan’s “unconscious structured like a language” gives no room to the id. Melanie Klein, although she preserves the priority of the instincts, gives pride of place to the aggressive and death instincts. However, some French analysts who are not exclusively Lacanian continue to work on the id.

Freud himself gave his followers a free hand, as witness the following observation on the division into id, ego, and superego: “It must not be supposed that these very general ideas are presuppositions upon which the work of psycho-analysis depends. On the contrary, they are its latest conclusions and are ‘open to revision.’ Psycho-analysis is founded securely upon the observation of the facts of mental life; and for that very reason its theoretical superstructure is still incomplete and subject to constant alteration” (1926f, p. 266).

A coherent advance in metapsychology that respected Freud’s requirements with respect to mental dynamics would certainly not be able to dispense with the conceptual tools of qualitative dynamics, as developed during the nineteenth century. This approach posits spaces articulated with each other by sets of dynamics that give rise to specific forms. It would make it possible to illuminate the way in which the ego and the superego arise from the id and from reality; to specify and explain the various processes of identification; to characterize inherited memory-traces as well

as types of governing dynamics; and to distinguish between energies of different kinds—and this while respecting the diversity of the id.

MICHÈLE PORTE

*See also:* Agency; Psychic apparatus; Resistance; Super-ego; Topographical point of view.

### **Bibliography**

- Freud, Sigmund. (1920g). Beyond the pleasure principle. *SE*, 18: 1–64.
- . (1921c). Group psychology and the analysis of the ego. *SE*, 18: 65–143.
- . (1923b). The ego and the id. *SE*, 19: 1–66.
- . (1924f [1923]). A short account of psycho-analysis. *SE*, 19: 189–209.
- . (1926d). Inhibitions, symptoms and anxiety. *SE*, 20: 75–172.
- . (1926e). The question of lay analysis. *SE*, 20: 177–250.
- . (1926f). Psycho-analysis. *SE*, 20: 259–270.
- . (1933a [1932]). New introductory lectures on psycho-analysis. *SE*, 22: 1–182.
- . (1937c). Analysis terminable and interminable. *SE*, 23: 209–253.
- . (1939a). Moses and monotheism. *SE*, 23: 1–137.
- . (1960a). *Letters of Sigmund Freud* (Ernst L. Freud, Ed. Tania and James Stern, Trans.). New York: Basic Books.
- Groddeck, Georg. (1928). *The book of the it: Psychoanalytic letters to a friend*. Washington, DC: Nervous and Mental Disease. (Original work published 1923)
- . (1977). *Ça et Moi. Lettres à Freud, Ferenczi et quelques autres* (R. Lewinter, Trans.). Paris: Gallimard.

### **Further Reading**

Shulman, Michael E. (1987). On the problem of the id in psychoanalytic theory. *International Journal of Psychoanalysis*, 68, 161–174.

---

## **IDEA / REPRESENTATION**

The term “representation” has two meanings in psychoanalysis: sense “A,” which is the conscious or pre-conscious evocation in internal mental space of an object or person, even an event in the external world;

and sense “B,” which refers to one of the two expressions (or “translations”) of a drive within psychic processes, the other being the “quota” or charge, of affect.

Sense A is the conventional meaning in philosophy and psychology. It is also found in Freudian metapsychology, a fundamental contribution of which was to describe it according to sense B, which is specific to psychoanalysis. Thus, there are two dimensions to representation, the first focused on the internal/external distinction (internal space of representation/external space of perception and action), the second on psychic topography (whether it involves the first topographical subsystem of conscious/preconscious/unconscious or the second of id/ego/superego, which does not replace the first). A full description of these two “orthogonal” dimensions does entail certain problems, however.

At this point it would be useful to introduce some terminological guidelines.

The term *representation* translates at least three terms used by Freud, although he never clearly distinguished among them:

- *Vorstellung*. This is an everyday word that literally means “that which is placed before, in front of, in the foreground.” The implication of the word “representation” is obviously quite different since it can mean that a second presentation is involved (this implication is dominant in sense A, but plays a less obvious role in sense B).
- *Repräsentant*. This is a much less common word, derived from Latin, which means “delegate,” “representative” (*Repräsentantenhaus*: “House of Representatives”), and is primarily applied to sense B (the drive “delegates” a representation in psychic life).
- *Idee*. The word means idea, conception, thought, and so on. It is the term Freud often used to refer to “dream thoughts.”

It is useful to distinguish the various senses of the concept of representation from related concepts such as “figuration” (especially in the dream work but also in the case of many creative activities), “symbol” (sometimes used by Freud as a synonym for “representation”), and “fantasy” (which can be considered as a representation or as a system of representations of a particular kind).

Freud's interest in these distinctions was evident even before the advent of psychoanalysis. In "On Aphasia: A Critical Study" (1891b), he defined aphasic disorders from a structural perspective, as disorders of semantic systems and, consequently, as disorders of representational systems—the "things" evoked by words. (We can trace the origin of the distinction he made in 1915 between "thing representation" and "word representation" to this essay.)

Freud then transposed these ideas onto the problem of the psychoneuroses. Even in his earliest descriptions of the affects, he emphasized how "irreconcilable ideas [representations]" come to be rejected by morality. But psychoanalysis truly came into being when he referred to this rejection as "repression," an active process that changes the status of representations, now unconscious but potentially active (through the return of the repressed); and when, at the same time, he also distinguished the vicissitudes of the two expressions for drives, representation and affect. Strictly speaking, it is only the representation that is subject to repression. It would be contradictory to speak of unconscious affects, emotions, or feelings, even though Freud subsequently referred to an "unconscious feeling of guilt." For what is unconscious is not the feeling itself, which has disappeared, but the still active mechanisms that generated it.

At this point we are confronted with, on the one hand, "floating" affects that are deprived of representational support and, consequently, are easily converted into anxiety, and, on the other hand, unconscious representations that attempt to return to satisfy the desire, as well as unrepressed conscious representations that in general are not, or only slightly, imbued with affect. It is these last, "suspended representations," that the floating affect will invest (in the military sense of blockading, or investing, a stronghold as well as in the economic sense, the way a fluid fills a container). Through this mechanism, the unconscious representation "delegates" the satisfaction of the desire to a representation or a group of representations that can enter consciousness. These views, which were clearly expressed between 1894 and 1896 (Freud, 1894a, 1895c, 1895d, 1896b), were developed in 1915, especially in "Repression" (1915d) and "The Unconscious" (1915e). André Green (1973) discussed these issues in a remarkable essay.

We see, then, how Freudian metapsychology attempted to differentiate the two senses: the representation

carries libidinal impulses that are cathected to it to the extent that it is potentially engaged with the external world, where the satisfaction will necessarily be sought. But this also raises serious problems concerning the relation between psychic reality and the reality of the external world—problems that Freud continued to struggle with throughout his career.

These problems are related to the activity of perception and memory. When the representation is, in the A sense, the internal "double" of an object, event, or person in the external world, it is assumed that the external reality has already been perceived and some trace of the perception has been retained. It is only under these conditions that the representation, in the B sense, will be able to be invested with a "quantum of affect."

Freud at first followed a rather simplistic theory of perception that was consonant with the empiricist-associationist school that dominated the late nineteenth century: perception functions like a recording device that faithfully transcribes the formal qualities of the perceived object, supplying "raw" material for the associative process. The resulting representations are themselves preserved unchanged in the form of "memory traces." But this raises a rather difficult problem: By what criteria can the subject distinguish a true perception (the German verb for perceiving is *wahrnehmen*, "to take to be true") from an illusion or hallucination?

Moreover, clinical work soon revealed the extent to which memory traces were manipulated through repression when they reappeared during the return of the repressed, were recathected by an affect, or were used for the disguised fulfillment of a desire. The perception itself, initially subject to psychic conflict, cannot be mistaken for a simple record, or inscription. It took a long time before Freud was able to acknowledge that every perception, every memory trace, and therefore every representation, is "constructed" by the dynamics of the psyche itself and undergoes a constant process of retroactive reworking (Perron, 1995). The controversies that ensued, advanced by "ego psychology," concerning basal cognitive functions conceived as "zones free of conflict," fell within the framework of these problems.

What enabled Freud to escape the empiricism of his early work (rather than associationism) was the awareness of desire. In "A Project for a Scientific Psychology"



(1950c), he states that desire originates with psychic life: under cover of need it reactivates the memory of the satisfaction and “supplies something similar to a perception, in other words, a hallucination” (1950c.). We must learn to distinguish between them and it is at this point that the difficult question of the “reality test” arises. A solution was indicated in a series of Freudian texts, including “Negation” (1925h) and *Inhibitions, Symptoms and Anxiety* (1926d).

The difference can be found in the introduction of disappointment, which should be added to the schema of maternal care. While the infant’s needs are satisfied by the mother (or her substitute), his desire is associated with an object, an object that will be progressively situated “externally” (and verified as such through its absence). If there is no satisfaction, the need persists (or is reborn, independent of hallucinatory satisfaction), and the child situates the desired object “inside himself.” Subject and object come into being together, along with the representation, now defined (as distinct from hallucination) as that which exists here, in me, in my internal space, but (not necessarily) there, in the external world. In this case, the child must determine “if something present in the ego as representation can also be found in the perception (reality). As we have seen this is again a question of outside and inside. The non-real, simply represented, the subjective, is only inside; the other, the real, is also present outside” (1925h).

Based on this information, a number of authors attempted to construct a coherent theory of the “origins of psychic life” (Perron-Borelli, Perron, 1997), including Donald Winnicott (transitional objects and transitional space), Wilfred Bion (the transition from beta elements to alpha elements, the function of the maternal daydream, preconceptions), and Piera Aulagnier (from the pictogram to utterances, primal—primary—secondary succession).

Fundamentally, as we have seen, representation is constituted as a double of the absent object, which it can evoke or cause to exist even when it is absent from the world of perceptions and actions; it is an absent presence. However, the same is true of the symbol. And Freud often used the two terms synonymously. He established a term-for-term correspondence, where the relation between representant and represented was equivalent to the relation between symbol and symbolized. But elsewhere he introduced a completely different approach, one—referred to as “structural”

above—in which the material of psychic life consists of “systems” of representations that are more or less cathected by affects. In these systems a representation only assumes meaning and functionality through its connection to other representations. This has analogies with linguistics, especially the work done by Ferdinand de Saussure and extensively employed by structural linguistics. We know, for example, that Jacques Lacan used this as the basis for constructing a profoundly original metapsychology.

It is appropriate at this point to examine the sense of the term “representation” that no longer refers to the product of psychic work but to the work itself, the process of representation. How is it distinguished from the process of symbolization (Gibeault, 1989)? Symbolization can be said to make use of material supplied by the systems of representation, which are themselves constantly changing. This, however, raises questions about the problem of fantasy.

It is difficult, in Freud’s writing as well as in the later literature, to differentiate the two concepts. However, by consensus, the following distinctions are generally accepted: Fantasy, much more so than representation, which need not be heavily cathected with affect, is invested with desire and the hallucinatory (or quasi-hallucinatory) satisfaction of this desire. Fantasy, however, cannot simply be characterized as a strongly cathected representation. It would be preferable to treat fantasy as a particular type of representation centered on satisfaction: the typical structure of the fantasy would, therefore, comprises an agent, an action, an object of the action. Transformations of this structure (through agent/object or active/passive reversals, the substitution of agents and objects)—a good example of which is provided in Freud’s article “A Child is Being Beaten” (1919e)—are part of the process of representation (Perron-Borelli, 1997).

The psychoanalytic process is obviously an incessant process of binding and unbinding representations and affects, giving them mobility in place of rigid and repetitive bindings. In therapeutic procedures, like those that make use of children’s drawings or psychoanalytic psychodrama, we see how perception, memory traces, figuration, and representation are interrelated. The procedure consists in encouraging the patient to produce figurations (drawings, mimetic actions) as perceptual objects. And it is preferable, to avoid confusion, to use the term “figuration,” which is precise where “representation” is ambiguous.

These figurations are based on psychic realities known as representations (and their variant, fantasies). They are present as objects of perception to the therapist and give rise in him to representations that are more or less in line with those of the patient, although not always perfectly aligned with them. These overlapping representations and their constant reworking are the very material of the therapeutic process to the extent that it attempts to remobilize the psychic life of the patient. Donald Winnicott, with his squiggle technique, and Marion Milner after him, have done a remarkable job in describing these processes.

ROGER PERRON

*See also:* Psychic representative; Representative.

### **Bibliography**

- Freud, Sigmund. (1925h). Negation. *SE*, 19: 233–239.
- Gibeault, Alain. (1989). Destins de la symbolisation. *Revue Française de Psychanalyse*, 53, 6, 1493–1617.
- Green, André. (1999). *The fabric of affect in the psychoanalytic discourse*. (Alan Sheridan, Trans.) London, New York: Routledge. (Original work published 1973)
- Perron, Roger. (1995). Théories de la psychogenèse. In *Encyclopédie médico-chirurgicale*, volume *Psychiatrie*. Paris: E.M.-C., fasc. 37-810-F-30.
- Perron-Borelli, Michèle. (1997). *Dynamique du fantasme*. Paris: Presses Universitaires de France.
- Perron-Borelli, Michèle, and Perron, Roger. (1997). *Fantasme, action, pensée*. Algiers: Éditions de la Société algérienne de psychologie.

## **IDEALIZATION**

Idealization is a concentrated libidinal investment in an object that is thus exalted and overvalued. The term first appeared in connection with Freud's definition of narcissism (1914), but the concept can already be found in *Leonardo da Vinci and a Memory of His Childhood* (1910), where Freud speaks of the biographer who sacrifices the truth to idealize the biographical subject, "reviving in him, perhaps, the child's idea of the father" (p. 130). From the time of the *Three Essays on the Theory of Sexuality* (1905), Freud used the notion of "sexual overvaluation" in relation to fetishism and sexual deviations. This overvaluation makes the subject dependent and submissive toward an object

containing traces of the earliest oedipal attachments: "One always returns to one's first love" (1905d, p. 154). This attitude reappears in the subject's passionate dependence on an idealized object.

Idealization involves an object of a drive, but not the drive itself. Since the origin of this libidinal overinvestment is unconscious, the investment appears to be an effect of the superior value of the object itself. The subject denies, however, that he is overinvesting and allows the overvalued object to remain overvalued. The subject thus overcomes ambivalence toward the object. This defense mechanism promotes an illusion that has effects in reality, both for the subject and those around the subject. The latter are at times forced to conform with an alienating image, as members of an idealized nation or race.

Idealization must be distinguished from both sublimation and identification with the ego ideal, even if the notion of value is prominent in each. Idealization and sublimation are comparable in that both notions involve a modification of early object choices and sexual aims. These two notions also involve a psychical working through that detaches the drive from its primitive support and sets it off in another direction as a partial drive. Finally, both concepts involve valuations expressed in the social sphere. But whereas sublimation allows the drive to deviate from its goal, idealization blocks it from attaining its goal—thus creating an inhibition—because of a feeling of inequality between the great object to be attained and the small subject who feels libidinally impoverished in comparison with the idealized object. Thus, in place of libidinal fulfillment, the subject experiences an inhibiting fascination or, as the case may be, a destructive rage.

Similarly, idealization of the object is different from identification with the ego ideal, first of all because in the former case the ego has impoverished libido, while in the latter case the ego introjects both the object and its qualities. Furthermore, in idealization the object is external to the ego, while in identification the object becomes internal. Most important, in idealization the object is set up in place of the ego ideal, while in identification it is the ego that takes the place of the object.

Idealization results from a failure of the superego and the ego ideal to form at the outcome of the oedipal conflict. In idealization, the ego cannot serve as the ideal in a healthy process of identification that would insure that the first idealized objects belong to the ego.

Instead, the ego is dispossessed of its narcissistic libido for the benefit of the independently existing, and thus alienating, object. It is thus forced to externalize its most important constitutive element, the ego ideal. This results in an infantile situation of helplessness, a “paralysis derived from the relation between someone with superior power and someone who is without power and helplessness” (1921c, p. 115). The notion of idealization thus enables one to understand both individual psychological mechanisms (such as passion, perversion, and psychotic identification) and collective ones (such as a group’s fascination with its leader).

Numerous authors have contributed to enriching the concept of idealization. Melanie Klein (1952) has developed the notions of the idealized good object and the persecutory bad object, Piera Aulagnier (1979) has written on idealization in passion and psychosis, and Janine Chasseguet-Smirgel (1975) has discussed the disease of ideality.

SOPHIE DE MIJOLLA-MELLOR

*See also:* Bipolar self; Desexualization; Ego ideal; Idealizing transference; Intellectualization; Narcissistic defenses; Paranoid-schizoid position; Passion.

### **Bibliography**

- Aulagnier, Piera. (1979). *Les destins du plaisir: aliénation, amour, passion*. Paris: Presses Universitaires de France.
- Chasseguet-Smirgel, Janine. (1985). *The ego ideal: A psychoanalytic essay on the malady of the ideal* (Paul Barrows, Trans.). London: Free Association Books. (Original work published 1975)
- Freud, Sigmund. (1905). Three essays on the theory of sexuality. *SE*, 7: 123–245.
- . (1910). Leonardo da Vinci and a memory of his childhood. *SE*, 11: 57–137.
- . (1914). On narcissism: an introduction. *SE*, 14: 67–102.
- . (1921). Group psychology and the analysis of the ego. *SE*, 18: 65–143.
- Klein, Melanie. (1946). Notes on some schizoid mechanisms. *International Journal of Psychoanalysis*, 27, 99–110.

### **Further Reading**

Lachmann, Frank M., and Stolorow, Robert D. (1976). Idealization and grandiosity: developmental considerations

and treatment implications. *Psychoanalytic Quarterly*, 45, 565–587.

## **IDEALIZED PARENTAL IMAGO**

The idealized parental imago is a narcissistic configuration that arises from the child’s attribution of former, lost narcissistic perfection to an admired and omnipotent self-object. A precursor of the Freudian ego ideal, it can be the object of a fixation and not be integrated into the self in order to lead to ideals, but instead remain a concrete self-object.

This notion appeared in Heinz Kohut’s article, “Forms and Transformations of Narcissism” (1966), and was formalized in his *Analysis of the Self* (1971). The idealized parental imago accounts for the need to merge with an all-powerful object and for religious and idealistic feelings of varying degrees of intensity. It gives rise to an idealizing transference in analysis.

In *The Restoration of the Self* (1977) Kohut conceived of it as a pole of the self, a possibility or potential for the self, which acquires its cohesion by responses of the self-objects that promote a sense of merging and calm. One pole can compensate for the other; idealization can compensate for deficient mirror responses. The self will be fragile only if both poles fail in their function.

These views of Kohut have been criticized on metapsychological grounds because they are based on the notion of an independent line of development for narcissism.

AGNÈS OPPENHEIMER

*See also:* Alter ego; Bipolar self; Idealizing transference; Narcissistic transference; Twinship transference/alter ego transference.

### **Bibliography**

- Kohut, Heinz. (1966). Forms and transformations of narcissism. *Journal of the American Psychoanalytic Association*, 14, 243–272.
- . (1971). *The analysis of the self*. New York: International Universities Press.
- . (1977). *The restoration of the self*. New York: International Universities Press.

## IDEALIZING TRANSFERENCE

An idealizing transference—in which an individual seems to say “you are perfect, and I am a part of you”—is defined as the mobilization of an all-powerful object, either spontaneously or as a reaction to the loss of narcissistic equilibrium. It illustrates the need for maintaining a narcissistic fusion against feelings of emptiness and powerlessness. It emerges from a fixation point—a “prestructural imago,” that is, one prior to the formation of agencies.

The term first appeared in 1968, in Heinz Kohut’s “The Psychoanalytic Treatment of Narcissistic Personality Disorders,” and he developed the concept starting in 1971, within the framework of narcissistic transferences, which are defined as the reactivation of narcissistic configurations in analyzable narcissistic personalities.

It is important to distinguish three different phenomena: the idealizing transference, the pseudo-idealizations, and idealization in the treatment of neurosis. The idealizing transference central to the treatment is stable even if it is present in different degrees, from the archaic fusion to a more evolved ideal. A break in this transference leads either to a more archaic idealizing transference, or a mirror transference when the libido is withdrawn from the archaic object.

The idealizing transference refers back to the imago of the idealized parent.

Kohut has been accused, particularly by the Kleinians, of letting patients develop an idealization that is not a factor of development, but rather a defense.

AGNÈS OPPENHEIMER

*See also:* Idealized parental imago; Self, the.

### Bibliography

Kohut, Heinz. (1968). The psychoanalytic treatment of narcissistic personality disorders. In *The search for the self* (vol. I, pp. 477–509). New York: International Universities Press.

———. (1971). *The analysis of the self*. New York: International Universities Press.

### Further Reading

Gedo, John E. (1975). Forms of idealization in the analytic transference. *Journal of the American Psychoanalytic Association*, 23, 485–506.

## IDEATIONAL REPRESENTATION

The notion of ideational representation was proposed by Piera Aulagnier. She distinguished three levels of representation: the pictogram, the fantasy, and the idea. Involved here are the three modes (representable, figurable, thinkable) through which the psyche metabolizes the information it draws from its encounter with reality. These three modes coexist, according to Aulagnier in *The Violence of Interpretation: From Pictogram to Statement* (1975/2001): “Every act, every experience, gives rise conjointly to a pictogram, to a *representation* and to ‘sense-making’” (p. xxx). The ideational representation is thus at the basis of the thinkable, which can be defined as a relational schema that the I imposes on the elements of both its own internal reality and the outside world in order to make them conform and cohere with the logic of the discourse from which the I itself is produced.

What distinguishes the ideational representation from the pictogram and the fantasy is the appearance on the mental stage of the word-presentation and the changes it will impose. On this point Aulagnier’s theory converges with that of Sigmund Freud, for whom an idea becomes conscious in conjunction with the appearance of the word-presentation. As he stated in “The Unconscious” (1915): “[T]he conscious presentation comprises the presentation of the thing plus the presentation of the word belonging to it, while the unconscious presentation is the presentation of the thing alone” (p. 201). Aulagnier emphasized the importance of the dimension of what is heard for the mental inscription of word-presentations in *The Violence of Interpretation*, recalling Ernest Cassirer’s description of “the infant’s first encounters with language as a series of sound fragments, attributes of a breast that he endows with the power of speech” (p. 55). There is then an adjunct of this “heard” to the thing-presentation, but this is still within the primary system, for the system of signification remains organized based on the postulate of the omnipotence of the desire of the Other. There is thus a first step in the infant’s psychic activity during language acquisition, in which libidinal meaning has priority over linguistic

meaning. Nevertheless, according to Aulagnier, this libidinal meaning traces an access to linguistic signification “by leading the psyche to accept that this meaning exists, that it is part of the representative’s inheritance and that this meaning is not unconnected to the offer or refusal present in the psyche’s response” (p. 65).

Alongside this, the infant’s thinking activity and thus the formation of ideational representations and language acquisition are part of what the mother expects for the child; at the same time these elements are also what will enable to child to gain its independence by keeping its thoughts secret. In contrast, if thinking is attacked by psychosis such secrecy is impossible. Aulagnier did not situate this attack, as Freud did in “The Unconscious,” in terms of a regressive treatment of word as thing, or of metaphor as concrete object (as Harold Searles did in “The Differentiation between Concrete and Metaphorical Thinking in the Recovering Schizophrenic Patient” [1962]) but instead on the basis of the fact that thinking, which constitutes the equivalent of an erogenous zone-function, can become the object of mutilations or amputations, depending on the relational field in which it develops.

SOPHIE DE MIJOLLA-MELLOR

*See also: Violence of Interpretation: From Pictogram to Statement, The.*

### **Bibliography**

- Castoriadis-Aulagnier, Piera. (2001). *The violence of interpretation: From pictogram to statement* (Alan Sheridan, Trans). Hove, England, and Philadelphia: Routledge. (Original work published in 1975)
- Freud, Sigmund. (1915e). The Unconscious. *SE*, 14: 159–204.
- Mijolla-Mellor, Sophie de. (1998). *Penser la psychose. Une lecture de Piera Aulagnier*. Paris: Dunod.
- Searles, Harold F. (1962). The differentiation between concrete and metaphorical thinking in the recovering schizophrenic patient. *Journal of the American Psychoanalytic Association*, 10 (1), 22–49.

---

## **IDEATIONAL REPRESENTATIVE**

The ideational representative is one of the two components of the instinctual representative (the mental

expression of the instinctual drive), the other being its charge, or “quota” of affect.

It was essentially in his 1915 articles brought together under the title “Metapsychology” (“Instincts and Their Vicissitudes,” “Repression,” and “The Unconscious”) that Freud dealt with these issues. The ideational representative can be conceptualized as a mnemonic trace of old perceptions. Strictly speaking, repression affects only this portion of the instinct; accordingly, it can be rendered unconscious, but can later return to consciousness in disguised form, with new, “innocent” associations, when, under the pressure of the instinctual drive, it manages to cross the barrier of censorship (this is the “return of the repressed”). Because of this, ideational representatives undergo constant transformations, during which they can again take on the charge of affects that had become “empty” at the time of repression. The other component of the psychic expression of the instinctual drive, the “quota of affect,” is not subject to repression; it can be “suppressed” (that is, undergo a quantitative attenuation that may go as far as nullification), undergo a qualitative change in nature (be felt differently), or be transformed into “free-floating” anxiety.

Of course, questions about what becomes of ideational representatives thus rejected “into the unconscious” have been raised: Are they really voided of affective charge there? Do they also, in the unconscious, undergo transformations in such a way that they change from there? Such issues quickly reach the point of unknowability, since it is not possible to talk about them except on the basis of returns of the repressed. Undoubtedly, then, from a perspective that is too exclusively topographical, the danger is to reify the agencies of the psyche as “contents” (a notion implicit in the expression “in the unconscious”) and to wonder about the status and fate of ideational representatives conceived as discrete elements that preserve their individuality and that can be traced. This trap can be avoided by returning to the very basis of the definition of the instinct, that is, the primacy of the economic, and by examining the conflictual dynamics at work in the transformations in question.

ROGER PERRON

*See also: Hallucinatory, the; Representative; Psychic representative; Scotomization.*

## Bibliography

- Green, André. (1999). *The fabric of affect in the psychoanalytic discourse* (Alan Sheridan, Trans.). London and New York: Routledge. (Original work published 1973)
- . (1995) *La Causalité psychique. Entre nature et culture*. Paris: Odile Jacob.
- Laplanche, Jean, and Jean-Bertrand Pontalis. (1973). *The language of psychoanalysis*. (Donald Nicholson-Smith, Trans.). London: Hogarth. (Original work published 1967)
- Le Guen, Claude, et al. (1986). Le refoulement (les défenses). *Revue française de psychanalyse*, 50, 1

## IDENTIFICATION

Identification is an unconscious mental process by which someone makes part of their personality conform to the personality of another, who serves as a model. Described cursorily by Freud in the context of psychopathology, the mechanism of identification has come to refer to a principal mode of relating to others and has been integrated in the processes that constitute the psyche. Identification should be distinguished from imitation, which is a voluntary and conscious act.

The notion of identification, in spite of its novelty and originality in the scientific or psychological vocabulary of the time, first appeared in Freud's writings in a letter to Wilhelm Fliess on December 17, 1896. It has always retained the meaning he gave it then: "I have confirmed, for instance, a long-standing suspicion about the mechanism of agoraphobia in women. You will guess it if you think of prostitutes. It is the repression of the impulse to take the first comer on the streets—envy of the prostitute and identification with her" (1985c, p. 182).

Freud often associated identification and hysterical symptoms with each other in subsequent writings, but he gave the concept a greater role in the *Interpretation of Dreams* (1900a), especially in the commentary that follows the dream of the "spiritual butcher," as Jacques Lacan referred to the dream of the dinner party where Freud refers to the wife's identification with a friend and presumed rival (chapter 4). Freud remarks that patients can "suffer as it were for a whole host of others, and to play all the roles in a drama solely out of their own personal resources." The classic definition follows: "[I]dentification is not simple imitation but assimilation on the basis of a similar aetiological

pretension; it expresses a resemblance and is derived from a common element which remains in the unconscious" (1900a, p. 150).

There is little doubt for Freud that this "aetiological claim" and "some factor held in common" are sexual in nature. Freud completes his description by demonstrating the dynamic use of identification under cover of another personality or composite formation, through the process of condensation and the use of a shared trait (the *einzigster Zug* that Jacques Lacan translated as "unary trait"), overcome censorship and realize the forbidden infantile wishes in the dream. The concept changed little in the following years, and in the Dora case it is used to account for the complexity of hysterical phenomena.

But in 1909 Sándor Ferenczi focused interest on the concept of identification when he introduced the similar notion of "introjection." For Ferenczi the ego "is always searching for objects to identify with, transference objects," and introjects them in order to grow. Object love is nothing but introjection. In the following years, in the study of Leonardo da Vinci (1910c), Freud explored this new pathway when he wrote that the young man who will become a homosexual "represses his love for his mother; he puts himself in her place, identifies himself with her, and takes his own person as a model in whose likeness he chooses the new objects of his love" (p. 100).

Likewise, "little Hans's" identification with the phobogenic animal, and therefore with his father (1909b), of the Rat Man with his father or mother (1909d), of little Arpad with a cock (Ferenczi, 1913), or the Wolf Man united with his parents during the primal scene (1918b [1914])—all are based on the model found in *Totem and Taboo* (1912–1913a), namely, the identification with the dead father during the totemic meal. The oral cannibalistic precursor of the mental mechanism of identification, named "incorporation," is clearly indicated in a note added in 1915 to the *Three Essays on the Theory of Sexuality* (1905d).

In 1915 the concept of identification was significantly modified, becoming a process integral to the history of the libidinal bonds woven between the ego and the other, even within the subject. The loss of an object narcissistically invested resulted in a phenomenon that Freud described in *Mourning and Melancholy* (1916–1917g [1915]) as "an identification of the ego with the abandoned object" (p. 249). It is

important to understand that this identification, here referred to as “melancholic,” is no longer partial and determined by a common trait as was hysterical identification, but total and brought about by withdrawal of the libido, which returns from the lost object to the ego. This was soon after referred to as “narcissistic identification” and considered to be more primal than ordinary identification.

In *Group Psychology and the Analysis of the Ego* (1921c), Freud describes three forms of identification: “First, identification is the original form of emotional tie with an object; secondly, in a regressive way it becomes a substitute for a libidinal object-tie, as it were by means of introjection of the object into the ego; and thirdly, it may arise with any new perception of a common quality shared with some other person who is not an object of the sexual instinct” (107–108).

The first of these modalities provides an opportunity for Freud to express the dialectic of being and having, which he used later on several occasions. “A little boy will exhibit a special interest in his father; he would like to grow like him and be like him, and take his place everywhere. We may say simply that he takes his father as his ideal” (p. 105). But the initial ambivalence evolves under the pressure of the Oedipus complex, either toward rivalry with the father or homosexual cathexis through identification with the mother. “It is easy to state in a formula the distinction between an identification with the father and the choice of the father as an object. In the first case one’s father is what one would like to *be*, and in the second he is what one would like to *have*” (p. 106). Seventeen years later, on July 12, 1938, this opposition would continue to disturb Freud, who left a brief trace in his writings: “‘Having’ and ‘being’ in children. Children like expressing an object-relation by an identification: ‘I am the object.’ ‘Having’ is the later of the two; after loss of the object it relapses into ‘being.’ Example: the breast. ‘The breast is a part of me, I am the breast.’ Only later: ‘I have it’—that is, ‘I am not it’” (1941f [1938], p. 299).

The second modality indicates the replacement of an erotic attachment, associated with the Oedipus complex, through identification and regression. A little girl coughs like her mother. “You are like her, but through suffering.” Dora coughs like the love object, her father. In both cases identification is only partial,

entirely limited, the ego restricting itself to borrowing only one of the object’s traits.

The third modality is original. It introduces the new concept of the ego ideal and embodies it in the person of the “leader.” This projection of the ideal promotes the social life of subjects who will be able to identify with one another through this common bond to an other, instead of considering one another as rivals to be destroyed. Young girls with a crush on the same singer are not jealous of one another; the loyal partisans of a leader forget their quarrels and differences. One point needs to be remembered, however: Identification is not here determined by the sexual bond that characterized the community of hysterical identification, which introduced the use of groups and “masses” in sociological research.

With the introduction of the “mythology” of the life and death instincts, and the description of the second topographical subsystem, the concept of identification changed in ways that would continue to enrich it. The nodal situation given to the Oedipus complex led to the description of complex interconnected identifications with each of the parents, which are made and unmade based on the number of possibilities for change and the data concerning their bisexual constitution.

Along with these “hysterical” forms of identification, narcissistic identification assumes particular importance in the formation of the subject. “Since then we have come to understand that this kind of substitution has a great share in determining the form taken by the ego and that it makes an essential contribution towards building up what is called its ‘character’” (1923b, p. 28). A number of post-Freudian authors like Theodor Reik went so far as to see this as a formative process for the ego itself. This insight helps contextualize the following remarks by Freud concerning the necessary withdrawal of cathexis from libidinal objects, which evolutionary change forces the id to abandon: “It may be that this identification is the sole condition under which the id can give up its objects. . . . When the ego assumes the features of the object, it is forcing itself, so to speak, upon the id as a love-object and is trying to make good the id’s loss by saying: ‘Look, you can love me too—I am so like the object’” (p. 29–30).

Subsequently, Freud defined what he referred to as “primary identification” (*primäre Identifizierung*), a

fundamental process in human mental development that represents a mythical moment similar to that of primary narcissism, primary repression, or even the murder of the father by the primitive horde. The term led to a number of contradictions and misunderstandings, for the term “primary identification” was used to refer to infantile identification of the baby with its mother, something not intended by Freud. As a sign of becoming human he understands it to mean an identification with the “father in his own personal prehistory” (1923b, p. 31) that occurs prior to any form of object choice. It splits the id from the ego ideal, the first split that signifies their connection, which the theory of the formation of the superego subsequently refines. The injunction associated with identification, to “You ought to be like this (like your father),” contradicts the later admonition: “You may not be like this (like your father)” (p. 34). In response to the evolution of the Oedipus complex and the fear of castration, the superego imposes itself as the introjection of the father in his controlling capacity through a later resumption of the primary identification. “Thus we have said repeatedly that the ego is formed to a great extent out of identifications which take the place of abandoned cathexes by the id; that the first of these identifications always behave as a special agency in the ego and stand apart from the ego in the form of a super-ego, while later on, as it grows stronger, the ego may become more resistant to the influences of such identifications. The super-ego owes its special position in the ego, or in relation to the ego, to a factor which must be considered from two sides: on the one hand it was the first identification and one which took place while the ego was still feeble, and on the other hand it is the heir to the Oedipus complex and has thus introduced the most momentous objects into the ego” (1923b, p. 48).

In “The Dissolution of the Oedipus Complex” (1924d), Freud returned to his description while emphasizing the role of the fear of castration. Because of this, “the object-cathexes are given up and replaced by identifications. The authority of the father or the parents is introjected into the ego, and there it forms the nucleus of the super-ego, which takes over the severity of the father and perpetuates his prohibition against incest, and so secures the ego from the return of the libidinal object-cathexis. The libidinal trends belonging to the Oedipus complex are in part desexualized and sublimated (a thing which probably happens with every

transformation into an identification) and in part inhibited in their aim and changed into impulses of affection” (p. 176–77). Here Freud uses the notion of introjection as a sign of a form of assimilation that is more stable and less labile than identifications would be, being closely associated with fantasy. This is a modification of the concept defined earlier by Sándor Ferenczi and another example of the terminological misunderstandings that have hampered the evolution of the concept of identification. In any case “the super-ego retained essential features of the introjected persons—their strength, their severity, their inclination to supervise and to punish” (p. 167), Freud wrote in “The Economic Problem of Masochism” (1924c).

Freud’s final thoughts on identification reveal his confusion in the face of its conceptual complexity. In chapter 31 of the *New Introductory Lectures* (1933a), entitled, “Decomposition of the Psychic Personality,” he again attempts—and for the last time—to clarify the various processes he designates as being part of identification and concludes, “I am absolutely not satisfied myself with these developments concerning identification.” But he adds a comment that will open a pathway to research on the phenomena of transmission between generations:

As a rule parents and authorities analogous to them follow the precepts of their own super-egos in educating children. Whatever understanding their ego may have come to with their super-ego, they are severe and exacting in educating children. They have forgotten the difficulties of their own childhood and they are glad to be able now to identify themselves fully with their own parents who in the past laid such severe restrictions upon them. Thus a child’s super-ego is in fact constructed on the model not of its parents but of its parents’ super-ego; the contents which fill it are the same and it becomes the vehicle of tradition and of all the time-resisting judgments of value which have propagated themselves in this manner from generation to generation.... Mankind never lives entirely in the present. The past, the tradition of the race and of the people, lives on in the ideologies of the super-ego, and yields only slowly to the influences of the present and to new changes; and so long as it operates through the super-ego it plays a powerful part in human life, independently of economic conditions (1933a, p. 67).

The “cruel” father himself had a father whom he took as a model, as well as a mother, and they too had



a mother and a father. Every parent replays in his child the world of his own childhood as it has remained engraved in his unconscious and his preconscious fantasies, far removed from the versions he communicates to others or keeps hidden from his conscious memories. It is this universe of origins that the investigative drive of every child explores to discover the secrets of its birth and identity. For its personality is formed with this material of composite images that may one day return in the form of “visitors of the ego” (Mijolla).

Post-Freudian authors have emphasized the psychoanalytic situation surrounding the concept of identification, which Freud did not examine in terms of identification. They have insisted on the necessity and limits associated with transference identification from the patient to the analyst, emphasizing that the analyst must possess a certain amount of empathy (*Einfühlung*), the ability to “understand what is foreign to our ego in other persons” (Freud, 1921c), and even to understand and interpret the analysand’s unconscious. Identification with Freud, the founding father, although the source of intense disagreement among his contemporaries and immediate successors, nonetheless remains one of the most vital areas of interest for the analyst. Fantasies of identification, with Freud or with individuals within the “psychoanalytic genealogy” of analysts, can lead to an understanding of certain theoretical propositions and events in the history of psychoanalysis.

Both Anna Freud, through her work on identification with the aggressor, and Melanie Klein, through her work on projective identification, have helped clarify various modes of identification that have confirmed the heuristic benefits of this evasive concept. The interest in relations with the mother has led to a misreading of primary identification, whose paternal-phallic nature was identified by Freud. Following Edith Jacobsen, other authors have presented it as a pre-object archaic mother-child relation situated in a state of fusion/confusion between the self and the not-self (Sandler), and have distinguished it from the concept of “imitation” borrowed from psychological models.

The distinction between “internalization,” comprising incorporation, imitation, and introjection, and associated with the construction of identity (Hartmann, Kris, and Loewenstein), and “externalization” as the distinction between internal objects and

external objects, has placed identification at the crossroads of these different systems. Its narcissistic pole has also been elucidated in the so-called “mirror” relation between mother and child, which is distinct from the specular identification of the child at the mirror stage, described by Jacques Lacan (1949). “Secondary identifications” have been isolated to describe the identificatory processes associated with the appearance and growth of the object relation, of pre-oedipal, oedipal and post-oedipal relations, and so on.

Psychoanalytic interest in more serious pathologies has drawn attention to the challenges to identity, whether these involve the behavioral disturbances of adolescence or the depersonalization observed in borderline or psychotic patients. Long before he addressed these issues in his essay on Justice Schreber (1912a), Freud, in a letter to Wilhelm Fliess (December 9, 1899), noted that “paranoia dissolves the identification once more; it re-establishes all the figures loved in childhood which have been abandoned ... and it dissolves the ego itself into extraneous figures” (1950a, p. 280).

More recently, research on identification has branched off in several directions: “counter-identification,” the “identificatory project” (Piera Aulagnier), “archaic identification,” “heroic identification” (Didier Anzieu), and “fantasies of unconscious identification” (Mijolla). The number of statements made to account for the richness of the concept seems interminable and psychoanalysts are still trying to determine its nature and formation.

ALAIN DE MIJOLLA

*See also:* Adhesive identification; Adolescent crisis; Allergic object relation; Alter ego; Animus-Anima (analytical psychology); As if personality; Asthma; Autohistorization; Character formation; Collective psychology; Counter-identification; Cultural transmission; Dead mother complex; Defense mechanism; “Dostoyevsky and Parricide”; Ego; *Ego and the Id, The*; Ego ideal; Empathy; Fetishism; Heroic identification; Holding; Homosexuality; Hysteria; Idealization; Identification fantasies; Identification with the aggressor; Identificatory project; Identity; Imaginary identification/symbolic identification; Introjection; “Introjection and Transference”; Little Arpåd, the boy pecked by a cock; Mastery; Megalomania; Melancholia; Melancholic depression; Midlife Crisis; “Mourning and Melancholia”; Narcissism; Object; Orality; Object relations theory; Phantom; Primary

identification; Psychotic potential; Self-hatred; Superego; *Thalassa. A Theory of Genitality*; Transference (analytical psychology); *Transference and Countertransference*; Transference relationship; Transitional object, space.

### Bibliography

- Ferenczi, Sándor. (1916). Introjection and transference. In his *Contributions to Psychoanalysis* (Ernest Jones, Trans.; pp. 30–80). Boston: Richard G. Badger. (Original work published 1909)
- Florence, Jean. (1978). *L'Identification dans la théorie freudienne*. Brussels: Publications des facultés, Université Saint-Louis.
- Grunberger, Béla, and Chasseguet-Smirgel, Janine (Eds.). (1978). *L'Identification: l'autre c'est moi*. Paris: Tchou.
- Kanzer, Mark. (1985). Identification and its vicissitudes. *International Journal of Psycho-Analysis*, 66, 19.
- Mijolla, Alain de. (1986). *Les Visiteurs du Moi, fantasmes d'identification, Confluents psychanalytiques* (2nd ed.). Paris: Les Belles Lettres. (Original work published 1981)
- Mijolla, Alain de. (1987). Unconscious identification fantasies and family prehistory. *International Journal of Psychoanalysis*, 68, 397–403.

### Further Reading

- Silverman, Martin. (2002). The will to succeed and the capacity to do so: The power of positive identifications. *Psychoanalytic Quarterly*, 71, 777–800.
- Smith, Henry. (2001). Hearing voices: The fate of the analyst's identifications. *Journal of the American Psychoanalytic Association*, 49, 781–812.

## IDENTIFICATION FANTASIES

The term *identification fantasies* originally referred to imaginary constructions or even genuine unconscious fantasmatic scenarios through which the subject replaces a part of their Ego or Superego with a primordial figure from their family history, particularly the father, mother, or grandparents, such that this figure lives a small or large fragment of the individual's own existence as a substitute.

Only an interpretation that is integrated into an ongoing analytic process, where the psychoanalyst's own identification fantasies are also activated, makes it possible to detect these fantasies and understand their meaning as expressed through symptoms, behaviors, or even *delusions*, in the sense that Sigmund Freud spoke of delusions in the case of the Rat Man (1909d).

Used similarly by Alain de Mijolla in “La désertion du capitaine Rimbaud” (“Captain Rimbaud's desertion”; 1975/1981), the notion of identification fantasies was later used in the description of less pathological phenomena. It was especially useful in bringing a new theoretical perspective to the study of *transgenerational* phenomena, an area previously dominated by the overly mythical idea of “transmission from unconscious to unconscious,” by providing the conditions for a more psychoanalytic consideration of the fantasmatic genealogy of each individual. Transmission does indeed occur, but by way of preconscious processes involving the third-party transmitters that are the earliest objects: parents or grandparents establish a relationship between the child and preceding generations via stories, traditions, secrets, and legends, which are thus perpetuated from generation to generation with varying degrees of alteration along the way. Given this fact, it is important from a psychoanalytic point of view to substitute the term *intergenerational* for *transgenerational* (the latter in any case being borrowed from other theoretical systems).

Identification fantasies often assume the guise of *screen-identifications* that involve a staging of personalities that are foreign to the subject, such as fashionable celebrities, idealized versions of people close to the subject, or legendary figures, but analysis can reveal their original, more modest, familial models.

The notion of fantasies is essential, for the “truth” the child refers to in exploring his or her prehistory is not necessarily that of actual, recognized and dated events (although why not, if such information is available?), but can be made up of more or less disparate fragments of representations and affects. These elements are often organized into “scenes” that fill gaps in the individual's history, and whose assimilation, or *introjection*, to use Sándor Ferenczi's first definition of that term, enriches the Ego by providing additional coherence to the subject's psychic universe. Such fantasies are not decorative but rather, like any other fantasy, offer libidinal satisfaction and an outlet for the actualization of desires within the dynamics of the drives.

Grandparents, whether living or dead, are an essential part of this process of fantasmatic genealogical organization, since the conscious and unconscious representations of them that are kept and transmitted by the child's parents are as essential to the formation of identification fantasies as the child's own perception of external reality, if not more so.

Psychoanalytic treatment is the best-adapted context for the recollection and opening up of identification fantasies, and for a repetition of the primitive quest that led to their construction. It is because the psychoanalyst allows the patient's fantasies to resonate within himself or herself, where they awaken echoes of the analyst's own intrapsychic explorations, that these fantasies can become a common ground where interpretation is possible and communicable.

ALAIN DE MIJOLLA

*See also:* Identification; Intergenerational; Phantom; Primal fantasy; Secret.

### **Bibliography**

- Freud, Sigmund. (1909d). Notes upon a case of obsessional neurosis. *SE*, 10: 151–318.
- Halfron, Olivier, Ansermet, François, and Blaise, Pierrehumbert (Eds.). (2000). *Filiations psychiques*. Paris: Presses Universitaires de France.
- Mijolla, Alain de. (1981). La désertion du capitaine Rimbaud. *Les visiteurs du moi, fantasmes d'identifications*. Paris: Les Belles Lettres. (Originally published 1975)
- Mijolla, Alain de. (1987). Unconscious identification fantasies and family prehistory. *International Journal of Psychoanalysis*, 68, 397–403.
- Mijolla, Alain de. (2004). *Prehistoire, de famille*. Paris: Presses Universitaires de France.

## **IDENTIFICATION WITH THE AGGRESSOR**

Identification with the aggressor was first described by Anna Freud in her book *The Ego and the Mechanisms of Defence*, first published in German in 1936.

In that book, Anna Freud drew a distinction between defenses directed against drive derivatives (to protect the ego against instinctual demands) and defenses against affects. The former included defenses that had long been recognized, such as repression, regression, reaction formation, introjection, projection, isolation, and undoing, as well as vicissitudes of instinct such as reversal and turning against the self which still need the intervention of the ego for their operation. To these nine mechanisms Anna Freud added a tenth: sublimation, or displacement of instinctual aims. Nonetheless, Anna Freud was well aware of the adaptive function of sublimation.

Defenses against painful affects (which may be regarded as “preliminary stages of defense”) include denial in fantasy, denial in word and deed, restriction of the ego (a defensive form of altruism), and identification with the aggressor, with which we are here concerned.

Jenny Wäelder, in a verbal communication to Anna Freud, had already given a striking picture of this mechanism in a five-year-old boy. Whenever the clinical material was about to touch on the question of masturbation or masturbatory fantasies, the normally inhibited little boy became extremely aggressive: for example, he would pretend to be a roaring lion and attack the analyst. He carried a rod about with him and pretended to be a devil, using it to attack the stairs and other parts of the room, and trying to strike his mother and grandmother. Matters came to a head when he began to brandish kitchen knives. Analysis showed that he was expecting punishment for what he regarded as forbidden activities. In his violent behavior he was both dramatizing and forestalling the attacks that he feared, and the kitchen knives pointed to his fear that his penis would be cut off.

A little boy whose Oedipus complex was at its height used this defense mechanism to try to deal with his sexual wishes towards his mother. Hitherto his relations with her had been very happy, but were now punctuated by outbursts of resentment. He would criticize her in the strongest terms for all sorts of reasons, of which the most mysterious was curiosity. This was not too difficult to explain: in his fantasies the mother knew of his sexual wishes towards her and rejected his advances with indignation. The indignation was replicated in his own outbursts of resentment, though he did not reproach her on general grounds but on those of curiosity. But the curiosity was a feature of his own instinctual life, not his mother's; he had found his scopophilic impulse the most difficult to master. Thus, defensively, he reversed the roles of parent and child.

These and other examples are described by Anna Freud. Essentially, identification with the aggressor points to a particular phase in the development of super-ego functioning, as she pointed out. For although external criticism has been introjected, the link between the fear of punishment and the offense committed has not yet been established in the patient's mind. Once the criticism is internalized, therefore, the offence is externalized—a maneuver that involves another mechanism, the projection of guilt. As Anna

Freud put it, intolerance of other people precedes severity towards oneself.

CLIFFORD YORKE

See also: Altruism; *Ego and the Mechanisms of Defence*, *The*; Ego psychology; Identification.

### **Bibliography**

Freud, Anna. (1946). *The ego and the mechanisms of defence*. New York, International Universities Press, 1966. (Original work published 1936)

## **IDENTIFICATORY PROJECT**

The notion of the identificatory project was proposed by Piera Aulagnier to account for the I's (the perceived self's) work of identification as a function of future time. In *The Violence of Interpretation: From Pictogram to Statement* (1975), Aulagnier defined the identificatory project as "that continuous self-construction of the I by the I that is necessary if that agency is to be able to project itself into a temporal movement, a projection on which the I's very existence depends" (p. 114). The temporal dimension that is projected onto both the past of memory (in auto-historization) and the imagined future (in the identificatory project) is the basis for the I's ability to respond in its own name to the unavoidable questions that sum up the identification process: "Who am I?" and "What must the I become?"

Aulagnier's theory of identification owes a great deal to Jacques Lacan. For her, it is the mother who initially identifies the preverbal infant as the entity that demands what she gives; because of this, the infant depends upon the maternal imaginary. But at the same time, the infant self-represents itself based on the "pictographic representation" it has of its earliest experiences of pleasure. The second phase of identification, which follows this primary period, is specular identification (the mirror stage). In Lacan's theorization, this stage shapes the function of the I and establishes the imaginary register as the locus of the ego's identifications ("The Mirror State As Formative of the Function of the I As Revealed in Psychoanalytic Experience" [1949/2004]). For her part, Aulagnier emphasized that after the young child recognizes the image in the mirror as being its own, it turns toward his mother seeking approval in her gaze; this enables

the child to see in the mirror "the junction between the image and the legend" (p. 124). In these conditions, object-libido and ego-libido are joined together; the baby discovers in the image the entity whose presence brings pleasure to the mother and in turn derives pleasure from the valorization of this image that he knows to be his own. Hence the definition that Aulagnier proposed with regard to the second phase of identification: "To be like the image that others admire or to be like the image admired by those whom the I admires are the two formulations that the narcissistic wish borrows from the field of identifications" (p. 126).

With the notion of "identification with the projection" (1968/1986), which in *The Violence of Interpretation* became the "identificatory project," a fundamental change took place. The immediacy of the exchange of care, contact, and gazes was succeeded by the temporal distance of the project(ion) referring to a time in the future. However, the possibility of access to the dimension of a genuine future (one that is not merely a coming reactualization of the past) is not automatic, and it is the trial of castration that gives the subject such access.

Aulagnier likened what she calls the identificatory project to what Freud called "ego ideals." She also underscored its difficulty: "The I's task is to become capable of thinking its own temporality. To do this it must think, anticipate, and invest in a future time-space, despite the fact that lived experience will quickly reveal that in doing so, the I is investing not only in the unforeseeable, but also in a time that it might not even have to live. In other words, the I is cathecting an 'object' and a 'goal' that possess the properties that it most abhors: precariousness, unpredictability, and the possibility of inadequacy."

In the "something less" borne in the present, by comparison with the ideal-filled future, Aulagnier proposed in *The Violence of Interpretation* to see "the assumption of the castration trial in the identificatory register" (p. 116), meaning that the I will never coincide with its ideal in the present of a realization, but instead will always project it forward in time. The identificatory register can thus be seen to be indissociable from the libidinal register, because a representation of the desiring subject always figures there. Being, or rather, knowing who one is, is essentially knowing who one wants to become. This opens the way for extending these ideas into clinical practice, not only

with regard to psychosis, but in other areas ranging from geriatric depression to adolescent turmoil.

SOPHIE DE MIJOLLA-MELLOR

*See also:* I; Identification; Mastery; Psychic temporality; Time; *Violence of Interpretation, The: From Pictogram to Statement.*

### **Bibliography**

- Aulagnier, Piera. (1986). *Demande et identification*. In *Un interprète en quête de sens*. Paris: Ramsay. (Original work published 1968)
- . (2001). *The violence of interpretation: From pictogram to statement*. (Alan Sheridan, Trans.). Hove, U.K., and Philadelphia: Brunner/Routledge. (Original work published 1975)
- . (1978). *La violence de l'interprétation du pictogramme à l'énoncé*. Paris, Presses Universitaires de France, 1975, 363 pp.
- Lacan, Jacques. (2004). The mirror state as formative of the function of the I as revealed in psychoanalytic experience. In *Écrits: A selection* (Bruce Fink, Trans., pp. 3–9). New York: W. W. Norton. (Original work published 1949)
- Mijolla-Mellor, Sophie de. (1998). *Penser la psychose. Une lecture de Piera Aulagnier*. Paris: Dunod.

## **IDENTITY**

Identity is not a Freudian concept. Theoreticians have defined it in very different ways: as a structure that accounts for narcissism and is part of the ego; as the ability to remain the same despite changes; as a feeling of continuity; or as the sum of representations of the self.

The importance of the notion of identity in the United States is related to its use in ego-psychology, which considers the ego as a relatively autonomous and potentially conflict-free structure. Many theories of identity adapt a portion of Freud's view of the ego. Alongside the Freudian ego, which is a structure defined by its functions, another ego—or identity related to identifications—is posited (whether inside or outside ego-psychology) and conceived of as the outcome of a process of individuation.

The first mentions of the importance of the concept of identity for clinical practice and psychopathology date from the nineteen-fifties. When it first appeared

in psychoanalytic discourse, the concept of identity was associated with two approaches. The first was an attempt to extend the Freudian perspective to a general psychology that would include the ego's relationships with the surrounding world and guide research on child development. The second sought to apply psychoanalysis to pathologies, more serious than neurosis, characterized by disturbances of identity. Phyllis Greenacre evoked the internal and external faces of identity, and described their favorable and unfavorable aspects. Ralph Greenson isolated a screen-identity syndrome. Margaret Mahler viewed identity as a facet of development connected with object-relations, symbiosis, and the possibility of separation-individuation.

Two major psychoanalytical theorists have focused on identity. In 1956 Erik Erikson introduced the concept of an ego identity formed during adolescence, which served as a gauge of psychopathology. In 1961 Heinz Lichtenstein proposed giving identity the priority that the libido had for Freud. He considered it the keystone of psychopathology and eventually reframed Freudian metapsychology within a monist perspective that challenged the dualistic concept of identification.

Erikson hoped to explain human development epigenetically; the various stages of his model could not be reduced to the psychosexual level. The ego was not propelled by drives alone but must confront the challenges posed by the environment. Ego identity was the adolescent stage; it took over from various identifications and its successful establishment depended on the resolution of earlier developmental crises. Erikson's ego identity was defined by the unconscious quest for personal continuity, by the synthesis of the ego, and by group loyalties. It reflected an existential dimension of the ego. It was formed through a succession of syntheses of the ego whereby the conflicts of earlier stages were integrated. The opposite of ego identity was a diffusion of identity, a pathological syndrome in which representations of self and object are fluid and unintegrated, and oppositionalism and acting out are manifested. Otto Kernberg used this model as a diagnostic criterion for borderline states.

Lichtenstein looked upon human identity as a permanent dilemma because of the absence of any form of guarantee. The theme of an invariable identity arose from an unconscious imprint derived from the mother thanks to a process of mirror reflection. Variations on this theme constituted the feeling of identity, a creation unique to the child. Pathological developments

occurred when themes emerged that were impossible to satisfy yet necessary for the maintenance of identity. In such case a subject could be caught in a paradoxical oscillation between the search for an annihilating other and an isolating autonomy. The principle of identity was the central motivation for the human individual, who was obliged to maintain an identity under more or less continual threat. This principle replaced the reality principle in Lichtenstein's account, and the drives as well as the repetition compulsion were subservient to it. Identity was assimilated to narcissism, described as a primary thematic with secondary variants. It left room for the self, the fourth metapsychological dimension and third paradigm of psychoanalysis. Identity was part of an evolutionist view that rejected dualism of any kind.

Historically speaking, theories of identity were replaced by theories of the self and by the "self psychology" of Heinz Kohut.

These are psychological theories in which the unconscious and libido are secondary. As Freud pointed out, however, unity and synthesis are superficial concepts. Drawing on such criticism, Kohut characterized Erikson's identity as a descriptive psychosocial concept. Edith Jacobson questioned the relevance and universality of so-called disturbances of identity, which she considered exaggerated. Roy Schafer interpreted the emergence of the concept of identity as symptomatic of a subjectivity stripped of a mechanistic and reifying metapsychology and hence in need of reformulation. Merely descriptive theories of identity may be said to belong to the sphere of phenomenology. When the conceptual focus is on identity, the ego is cut off from its libidinal roots. Furthermore, the view that underpins these theories is exclusively developmental and completely rejects any causality based on deferred effects.

AGNÈS OPPENHEIMER

*See also:* Adhesive identification; Adolescent crisis; Anthropology and psychoanalysis; Double, the; Ego (ego psychology); Ego-identity; Identification; Imposter; Object relations theory; Principle of identity preservation; Projection and "participation mystique" (analytical psychology); Self-consciousness; Self-image; Self representation; Sexual identity; Symbiosis/symbiotic relation.

### **Bibliography**

- Erikson, Erik. (1956). The problem of ego identity. *Journal of the American Psychoanalytic Association*, 56–121.
- Greenacre, Phyllis. (1958). Early physical determinants in the development of the sense of identity. *Journal of the American Psychoanalytic Association*, 6, 612–627.
- Greenson, Roger. (1958). Variations in classical psychoanalytic technique. *International Journal of Psycho-Analysis*, 29, 200–201.
- Lichtenstein, Heinz. (1983). Identity and sexuality. *The dilemma of human identity*. New York: Jason Aronson.
- Mahler, Margaret. (1958). Problems of identity. *Journal of the American Psychoanalytic Association*, 6, 131–142.

### **IDEOLOGY**

The word *ideology* refers to the study of ideas, a form of general or abstract discourse, immobilized thought (Piera Aulagnier, Sophie de Mijolla-Mellor), or any doctrine claiming to justify a collective activity of a political, religious, artistic, or other kind. When Antoine Destutt de Tracy in his *Mémoire sur la faculté de penser* (vol. 1, 1796–1798) and *Éléments d'idéologie* (1801) coined the word as an attempt to create a science of ideas, he remained nominally a Platonist in that he did not conceive of the term as derogatory, which it has since become. However, the Platonic "ideology" Alexandre Kojève described in his *Essai d'une histoire raisonnée de la philosophie païenne* (vol. II, *Platon et Aristote*) was not only a science of ideas but claimed to be the science of objective reality, the *Cosmos noëtos* conceived by Plato as the real, or essential world, interposed between the One and the sensible world (*Cosmos aisthètos*). Destutt de Tracy claimed to be an ideologue, as did Pierre Daunou, Constantin-François Volney, Pierre Cabanis, and Dominique Garat, but the term was used deprecatingly by Napoleon and François René de Chateaubriand.

In the work of Karl Marx, ideology assumed a critical sense that displayed the opposition between the "noble" sense given to it by Destutt de Tracy and its opposite, purely negative meaning; this opposition is itself "ideological." In the *German Ideology*, ideology is always the reflection of an alienation, an alienation obscured by the material conditions that determine the representations that constitute that alienation. Ideology, as an expression of alienation, is essentially incapable of grasping the dialectical relationships that

unite or resist those representations. By extension any non-critical system of representation is considered an ideology, for example, Catholic ideology or even Marxist ideology understood as the dogmatization of the results of Marx's critical thought (Leninism, Stalinism, etc.). Ideology would then be seen as the discourse of a class, a party, or an association that seeks to achieve or achieves cultural, political, economic, intellectual, spiritual, or other domination over society and individuals.

The essence of ideology could therefore be to weld a "collectivity" into a defensive system of representations based on an unconscious causality, material or structural, involving realities such as the Family, the Nation, the Army, the Church, the State, and so on. These can then be understood as ideological entities, just as "fixed" as individual doctrines or representations. "System," superstructure, doctrine, dogma, and so on, then become other possible synonyms for ideology.

Sigmund Freud gathered up all these meanings to express a "vision of the world" (*Weltanschauung*) whose various forms of representation philosophy elaborates in thought, which would make his research into truth the pinnacle of ideology. For philosophy is the work of sublimation while ideology, as Piera Aulagnier has shown, is an avatar of the desire for "self-alienation" (*Les Destins du plaisir*, 1979). Ideology—always and everywhere—corresponds to a "sublimated abandonment to an abstract idea" (Freud, Sigmund, 1921c). But as Sophie de Mijolla-Mellor has noted, "it isn't a question of sublimation but of intellectualization or desexualized abstraction; we do not give in to an idea but to its author, whether a group or an individual" (1992). Radical ideology might be a form of destructive madness to the extent that ideology tends to exclude conflict and sharply reduce ambivalence, thus resembling the discourse of schizophrenia.

DOMINIQUE AUFFRET

*See also:* Philosophy and psychoanalysis.

### **Bibliography**

Aulagnier, Piera. (1979). *Les Destins du plaisir. Aliénation, amour, passion*. Paris: Presses Universitaires de France.

Freud, Sigmund, (1921c). Group psychology and the analysis of the ego. *SE*, 18: 65–143.

Mijolla-Mellor, Sophie de. (1992). *Le Plaisir de pensée*. Paris: Presses Universitaires de France.

## **ILLUSION**

Illusion is an error experienced by someone who is misled (*illudere*) by the nature of evidence or the seductive appearance of something that deceives. The deceiver may be personified (Descartes's "evil genius") or limited to a physical or physiological cause (the illusions of the senses), or even an ontological structure (the Platonic myth of the cave). However, the subject can create his own illusion by taking his desires for reality. It is this last formulation that is embodied in the Freudian approach to illusion, defined as a belief primarily motivated by the realization of a desire. To that extent the illusion has much in common with dreams and dreaming, where the philosophers of antiquity had situated it.

The concept of illusion in Freud is gradually developed, reaching its culmination in *The Future of an Illusion* (1927c). In the *Project for a Scientific Psychology* (1950c [1895]), illusion is confused with hallucination in the context of perceptual illusion. But with the *Psychopathology of Everyday Life* (1901b), the concept is further refined. In Freud's case it would be wrong to qualify the feeling of *déjà vu* or *déjà éprouvé* as illusion, because they correspond, through displacement and concealment, to an authentic unconscious daydream. Thirty-five years later in "A Disturbance of Memory on the Acropolis," Freud would refer to false recognition (*déjà vu, déjà raconté*) as a part of the "illusions in which we seek to accept something as belonging to our ego, just as in the derealizations we are anxious to keep something out of us" (1936a, p. 245).

There is a certain amount of ambiguity concerning the simple criterion that defines illusion as something that doesn't exist in reality, to the extent that the concept of reality is reconsidered in psychoanalysis as mental reality. Moreover, the single stable criterion used to define illusion in psychoanalysis is a belief motivated by the realization of desire: "[W]e will call a belief an illusion when a wish-fulfilment is a prominent factor in its motivation, and in doing so we disregard its relations to reality, just as the illusion itself sets no store by verification" (1927c, p. 31).

Freud identifies illusion as being mostly associated with religion, art, and philosophy, but he also

acknowledges the hypothesis that science itself could be an illusion, although he rejects it. In a deeper sense the greatest illusion would be the belief in the happiness and goodness of human nature. This pessimism, or realism, is first associated with the illusion that lasting sexual satisfaction is possible (“‘Civilized’ Sexual Morality and Modern Nervous Illness,” 1908d) and that social rules should be modified to procure happiness for individuals. Freud then assumes the position of a defender of a realist position, which includes negativity instead of ignoring it: “Because we destroy illusion we are accused of endangering ideals” (1910d, p. 147). In fact the only ideal he defends is that of truth. He further distinguishes two types of illusions: those that are not harmful since the illusion is obvious, and those that are dangerous because they take the place of an objective apprehension of reality (philosophy, ideology, and especially religion).

To the first category belongs art, which is said to evolve from magic and which, as an artistic illusion, produces the same affective effects as if it involved something real (1912–1913a). “Art is said to be almost always harmless and beneficent; it does not seek to be anything but an illusion.” (1933a [1932], p. 160). In what sense is art an illusion? Freud is forced to make use of the concept of reality to determine this. “The substitutive satisfactions, as offered by art, are illusions in contrast with reality, but they are none the less psychically effective, thanks to the role which phantasy has assumed in mental life” (1930a [1929], p. 75). Illusion, and especially the ability to take pleasure in it, would therefore be the result of the magical omnipotence associated with the beginnings of mental life, which led to the separation of the life of the imagination from the mental life grafted to reality, “At the time when the development of the sense of reality took place, this region [imagination] was expressly exempted from the demands of reality-testing and was set apart for the purpose of fulfilling wishes which were difficult to carry out” (1930a [1929], p. 80).

But reality-testing is difficult to manage when defining illusion. Freud emphasizes it when he distinguishes illusion from delusion: “Illusions need not necessarily be false—that is to say, unrealizable or in contradiction to reality” (1927c, p. 31). The example chosen (the illusion of a young woman of modest means of being able to marry a prince) is not convincing, because within the framework of erotomaniacal delusion, that same idea (not illusory since it is realizable, Freud says) would

indeed appear to contradict reality. We could therefore say that delusion has more to do with a difference in “temporality”—hope and expectation in one case, real certainty on the other.

The difference between the potential reality of the content of the illusion and the belief in its actual reality is what allows reality testing to be used to define the illusion. Illusion primarily involves the *Wel-tanschauung* and, in this regard, Freud emphasized religious illusion. All religious doctrines are “illusions and unsusceptible of proof. No one can be compelled to think them true, to believe in them” (1927c, p. 31). The desire they realize is that of being protected and loved by a father who is more powerful than the real father. Infantile distress is the origin of religious need, which Freud criticizes because of the weight it places on education. He also feels—and this may sound paradoxical—that it is necessary to maintain religious teaching as a basis of education and human life in common. “If you want to expel religion from our European civilization, you can only do it by means of another system of doctrines; and such a system would from the outset take over all the psychological characteristics of religion—the same sanctity, rigidity and intolerance, the same prohibition of thought—for its own defense” (p. 51). In other words even if for Freud religion is a “serious enemy” of science, it would be an illusion to believe that it is possible to renounce belief for the benefit of knowledge alone.

The philosophical illusion that believes it can deliver an image of the world that is coherent and without gaps is undermined by the progress of science; and political illusion, such as communism, is an example of a substitute for religion. The struggle against illusion is therefore a battle that will only yield incomplete results, following a process of maturation that is never realized: “Since we are prepared to renounce a good part of our infantile wishes, we can bear it if a few of our expectations turn out to be illusions” (1927c, p. 54).

In psychoanalysis the concept of illusion has, in the work of Donald Woods Winnicott, undergone a completely different development than it has in Freud. Winnicott (1953/1971) defines illusion as the necessary adaptation of the mother to the needs of the baby, which allows her to experiment with narcissistic omnipotence from the beginning. This phase corresponds to the primary creativity of the infant and is prolonged during adulthood in art and religion. Winnicott’s



ideas extended Freudian theories of the “purified pleasure ego” and the “reality test.” Winnicott postulates the existence of “intermediate state between a baby’s inability and growing ability to recognize and accept reality” (1953, p. 90). This ability is strictly dependent on what the mother allows the baby to feel. “The mother’s adaptation to the infant’s needs, when good enough, gives the infant the illusion that there is an external reality that corresponds to the infant’s own capacity to create” (p. 95).

In other words, the reality test is experienced as a frontal shock, but the reality is initially constructed by the baby who perceives it as being part of himself. During a subsequent period, it will appear to be independent, but only gradually: “The mother’s eventual task is gradually to disillusion the infant, but she has no hope of success unless at first she has been able to give sufficient opportunity for illusion” (p. 95). But illusion as a form remains and serves as a binding factor: “We can share a respect for illusory experience, and if we wish we may collect together and form a group on the basis of the similarity of our illusory experiences. This is a natural root of grouping among human beings” (p. 90).

This differs from the Freudian point of view, which remains dependent on a certain proscientific militancy, while Winnicott situates himself at a level that is both more metaphysical and more affective. “It is assumed here that the task of reality-acceptance is never completed, that no human being is free from the strain of relating inner and outer reality, and that relief from this strain is provided by an intermediate area of experience which is not challenged (arts, religion, etc.). This intermediate area is in direct continuity with the play area of the small child who is ‘lost’ in play” (p. 95).

SOPHIE DE MIJOLLA-MELLOR

*See also:* Belief; Certainty; Erotomania; *Future of an Illusion, The*; Narcissistic elation; “Thoughts for the Times on War and Death”; Wish, hallucinatory satisfaction of a;

### **Bibliography**

- Freud, Sigmund. (1901b). The psychopathology of everyday life. *SE*, 6.
- . (1927c). The future of an illusion. *SE*, 21: 1–56.

———. (1933a [1932]). New introductory lectures on psycho-analysis. *SE*, 22: 1–182.

———. (1936a). A disturbance of memory on the Acropolis (an open letter to Romain Rolland on the occasion of his seventieth birthday). *SE*, 22: 239–248.

Winnicott, D. W. (1953). Transitional objects and transitional phenomena, a study of the first not-me possession. *International Journal of Psycho-Analysis*, 34, 89–97. Additional material in (1971). *Playing and reality* (pp. 1–30). London: Tavistock.

## **IMAGINARY IDENTIFICATION/SYMBOLIC IDENTIFICATION**

Jacques Lacan differentiated between an imaginary identification, that forms the ego from a symbolic one that founds the subject. He discussed the first in his essay on the “Mirror Stage” (1936) and he examined the second primarily in his seminar on *Identification* (1961–1962).

Imaginary identification involves the image of one’s “fellow being.” Before the subject develops the proper neurological connection, he grasps the unity of his body image by identifying with the image of the other, the ideal ego. Thus the subject escapes the feeling of having a fragmented body. The mirror stage is also the source of the aggressive tension that characterizes relations with the one’s fellow being, and it is the source of desire as the other’s.

Symbolic identification, or “signifier identification,” involves an ideal signifier—an insignia of the Other or a unary trait—as the nucleus of the ego-ideal that the subject depends on.

This situation is modeled on Freud’s second form of identification, that is, an identification by adopting a single trait taken from the object. In fact, imaginary identification depends on symbolic identification. In the mirror stage, the infant looks for a sign from the maternal Other holding him up to the mirror in order to confirm that the image is his. Behind the signifier of the ego-ideal are the Name-of-the-Father and the symbolic phallus.

A subject’s sexual identity does not depend on his relation to an image, but on his position in relation to the symbolic phallus—a male subject has it, while the female subject does not have it, but is it.

In the last years of his Seminar lectures, Lacan introduced the idea of identification with a symptom

and added it to the notions of imaginary and symbolic identification.

MARC DARMON

*See also:* Body image; Demand; Ego ideal/ideal ego; I; Identification; Mirror stage; Object *a*; Seminar, Lacan's; Unary trait.

### **Bibliography**

Lacan, Jacques. (2002). The mirror stage as formative of the *I* function as revealed in psychoanalytic experience. In *Écrits: A selection*. (Bruce Fink, Trans.). New York: W. W. Norton. (Original work published 1949).

———. *Le Séminaire-Livre IX, L'identification* (1961–62). (unpublished seminar).

## **IMAGINARY, THE (LACAN)**

In the work of Jacques Lacan, the real, the symbolic, and the imaginary are a central set of references. The imaginary is the field of the ego.

In his 1936 essay “Au-delà du ‘principe de réalité’” (Beyond the reality principle), Lacan noted that Freud discovered a meaning in patients’ complaints that other physicians considered imaginary and thus illusory. In his first reading of Freud’s work, Lacan emphasized the notion of the image by highlighting its function: reflecting the subject’s discrete behaviors in unified images. In the mirror stage, the subject identifies with these images and develops an ego concept in relation to another.

In his first seminar, Lacan acknowledged that such identification implies a radical alienation (1988a), but he considered this identification to be essential to the structure of the imaginary order and to the development of the human ego. At that time (1953–1954), he was interested in the ethological work of Nikolaas Tinbergen and Konrad Lorenz, which privileged the function of the image as gestalt in the development of the sexual instinct. Lacan believed that the development of the sexual drive of humans too is related to the imaginary function. This would account for the lure of images. As an example, he referred to the female stickleback, a fish whose copulatory dance is set in motion by the sight of a certain color patch on the male’s back. Yet a paper cutout bearing the same

markings can have the same effect on the female (Lacan, 1988a, pp. 122–123). What matters is that image is invested with libido. Lacan referred to libidinal investment as “what makes an object become desirable, that is to say, how it becomes confused with this more or less structured image which, in diverse ways, we carry with us” (1988a, p. 141).

But for the subject to come into being, one must find “a guide beyond the imaginary, on the level of the symbolic plane. . . . This guide governing the subject is the ego-ideal” (1988a, p. 141). The ego-ideal, according to Lacan, is the Other (caregiver) speaking. From that point on, the symbolic order (language) dominates over the imaginary order, which is reduced to being a decoy. It took Lacan twenty years to restore the imaginary to its full place alongside the real and the symbolic, which he did within the topic of the Borromean knot (a set of three interlinked rings that come apart if any one is removed).

In spite of Lacan’s focus, in 1982, on the importance of knotting the three consistencies (the real, the symbolic, and the imaginary), many Lacanians continue to neglect the imaginary. In his study of James Joyce (2001), however, Lacan showed the difficulties that follow from a failure to give proper place to the imaginary. According to Marie-Christine Laznik-Penot (1995), the treatment of autism also allows us to see the difficulties that can follow from failure to accord the imaginary order its proper place.

MARIE-CHRISTINE LAZNIK

*See also:* Blank/nondelusional psychoses; Demand; Desire of the subject; Ethology and psychoanalysis; Fantasy, formula of; Fort-Da; Frustration; Graph of Desire; I; Identificatory project; Imaginary identification/symbolic identification; Imago; Knot; Law of the father; Matheme; Mirror stage; Object *a*; Optical schema; Other, the; Phallus; Privation; Real, the (Lacan); Real, Imaginary, and Symbolic father; Schizophrenia; Self-image; Signifier; Structuralism and psychoanalysis; Subject; Subject’s castration; Symbolic, the (Lacan); Symptom/sinthome; Topology.

### **Bibliography**

Lacan, Jacques. (1936). Au-delà du “principe de réalité.” In his *Écrits*. Paris: Seuil, 1966, 73–92.

———. (1982). The seminar XXII of 21 January 1975: RSI. In Juliet Mitchell and Jacqueline Rose (Eds.), *Feminine sexuality*. New York: W. W. Norton.

———. (1988a). *The seminar of Jacques Lacan. Book 1: Freud's papers on technique (1953–1954)* (John Forrester, Trans.). New York: W. W. Norton.

———. (1988b). *The seminar of Jacques Lacan. Book 2: The ego in Freud's theory and in the technique of psychoanalysis (1954–1955)* (Sylvana Tomaselli, Trans.). New York: W. W. Norton.

———. (2001). Joyce: le symptôme. In his *Autres écrits*. Paris: Seuil.

Laznik-Penot, Marie-Christine. (1995). *Vers la parole: trois enfants autistes en psychanalyse*. Paris: Denoël.

## IMAGO

An unconscious prototype of personae, the imago determines the way in which the subject apprehends others. It is elaborated based on the earliest real and fantasmatic intersubjective relations with family members.

The term *imago* first appeared in work of Carl Gustav Jung in 1912, and the same Latin word was adopted in various languages. The concept was borrowed from a novel of the same name by Carl Spitteler (1845–1924), published in 1906. In Jungian psychology, the term *imago* eventually replaced the term *complex*.

The imago is linked to repression, which in neurosis, through regression, provokes the return of an old relationship or form of relationship, the reanimation of a parental imago. This regression is linked to particular quality of the unconscious, that of being constructed through historical stratification. “I have intentionally given primacy to the expression *imago* over the expression *complex*, for I wish to endow the psychical fact that I mean to designate by *imago*, by choosing the technical term, with living independence in the psychic hierarchy, that is, the autonomy that multiple experiences have shown us to be the essential particularity of the complex imbued with affect, and which is cast into relief by the concept of the imago,” Jung wrote.

Jung later replaced the term *imago* with *archetype* in order to express the idea that it involves impersonal, collective motifs, but in fact this idea was already present in his earliest descriptions of imagos. In 1933 he again explained his choice of this term: “This intrapsychical image comes from two sources: the influence of the parents, on the one hand, and the child's specific

relations, on the other. It is thus an image that only reproduces its model in an extremely conventional way.” Finally, he situated the imago “between the unconscious and consciousness, in a sense, as if in *chiaroscuro*.” It is a partially autonomous complex that is not completely integrated into consciousness.

Sigmund Freud, “forgetting” that Spitteler's novel had inspired Jung, used the same title, *Imago*, for the review he created with Hanns Sachs and Otto Rank in Vienna in March 1912.

The concept of the imago, very seldom used by Freud, appeared in his writings for the first time that same year, in “The Dynamics of Transference” (1912b), where he wrote: “If the ‘father-imago,’ to use the apt term introduced by Jung . . . is the decisive factor in bringing this about, the outcome will tally with the real relations of the subject to his doctor” (p. 100). In those rare texts where he used this term, the imago refers only to an erotic fixation related to real traits of primary objects. But elsewhere, Freud had already shown the importance of the child's links with its parents and had explained that the most important thing is the way in which the child subjectively perceives its parents; these ideas are contained in the notion of the imago. He had also distinguished certain representations that had the status of the imago (the mnemonic image of the mother, or the image of the phallic mother in the work of Leonardo da Vinci). However, in “The Economic Problem of Masochism” (1924) he used the term *imago* in the Jungian sense, in relation to moral masochism and the superego. Indeed, he wrote that behind the power exerted by the first objects of the libidinal instincts (the parents) was hidden the influence of the past and traditions. In his view, the figure of Destiny, the last figure in a series that begins with the parents, can come to be integrated with the agency of the superego if it is conceived of “in an impersonal way,” but quite often, in fact, it remains directly linked to the parental imagos.

At that time the term *imago* was commonly used in the psychoanalytic community, but it was particularly developed in the work of Melanie Klein. Besides the classic imagos, she described “combined parental imagos” that provoke the most terrible states of anxiety. She linked these to the “stage of the apogee of sadism,” which in 1946 became the “schizoid-paranoid position.” The analyst's work is to bring forth the anxiety linked to these terrifying imagos, thus facilitating the passage to “genital love” (which in 1934 became the

“depressive position”) by transforming these terrifying imagos into helpful or benevolent imagos. In her view, the young child develops cruel, aggressive fantasies about the parents. The child then projects these fantasies onto the parents, and thus has a distorted, unreal, and dangerous image of people around it. The child then introjects this image, which becomes the early superego. Klein thus described the early superego more as an imago than as an agency.

Klein left it to Susan Isaacs to define what she meant by imago: an image, or imago, is what is introjected during the process of introjection. It involves a complex phenomenon that begins with the concrete external object in order to become that which has been “taken into the self” (p. 89), that is, an internal object, Isaacs explained in “The Nature and Function of Phantasy” (1948), adding: “In psycho-analytic thought, we have heard more of ‘imago’ than of image. The distinctions between an ‘imago’ and ‘image’ might be summarized as: (a) ‘imago’ refers to an unconscious image; (b) ‘imago’ usually refers to a person or part of a person, the earliest objects, whilst ‘image’ may be of any object or situation, human or otherwise; and (c) ‘imago’ includes all the somatic and emotional elements in the subject’s relation to the imaged person, the bodily links in unconscious phantasy with the id, the phantasy of incorporation which underlies the process of introjection; whereas in the ‘image’ the somatic and much of the emotional elements are largely repressed” (p. 93).

In his 1938 article entitled *Les Complexes familiaux dans la formation de l’individu* (The family complexes in the formation of the individual), Jacques Lacan drew the connection between imago and complex. It was at this time that he advanced his first theory of the Imaginary. The imago is the constitutive element of the complex; the complex makes it possible to understand the structure of a family institution, caught between the cultural dimension that determines it and the imaginary links that organize it. Lacan described three stages in it: the weaning complex, the intrusion complex (in which the mirror stage is described), and the Oedipus complex. This complex-imago structure prefigured what would become his topology of the Real, the Imaginary, and the Symbolic.

ANTOINE DUCRET

*See also:* Combined parent figure; Idealized parental imago; Internal object; Maternal; Myth of the hero; Phallic mother; Transference depression.

### **Bibliography**

- Freud, Sigmund. (1912b). The dynamics of transference. *SE*, 12: 97–108.
- . (1924). The economic problem of masochism. *SE*, 19: 155–170.
- Isaacs, Susan. (1948). The nature and function of phantasy. *International Journal of Psycho-Analysis*, 29, 73–97.
- Jung, Carl Gustav. (1911-12, 1925 [1952a]), Psychology of the unconscious. A study of the transformation and symbolism of the libido. A contribution to the history of the evolution of the thought. *Coll. works*, Vol. 5, London, Routledge & Kegan Paul.
- Lacan, Jacques. (1984). *Les Complexes familiaux dans la formation de l’individu*. Paris: Navarin. (Original work published 1938)

---

## **IMAGO PUBLISHING COMPANY**

The destruction by the Nazis of the *Verlag* (International Psychoanalytic Press) was a bitter blow to Freud, and when he arrived in London in 1938 he tried to find some way of restoring it.

Already, in May of that year, Hanns Sachs had suggested that he establish a periodical in the United States that would be devoted to non-medical applications of psychoanalysis, especially to culture, and to call it the *American Imago*. In this way Sachs hoped to continue along the path pursued by the original *Imago*, founded by himself and Otto Rank in 1912, and of which he had remained co-editor. The name “Imago” was taken from the title of a novel by a Swiss poet, Carl Spitteler, that had underlined the importance of the unconscious in its motif, a love affair. According to Ernest Jones, Freud favored the Sachs plan, for which financial backing had been guaranteed by a well-wisher, but was somewhat reluctant to agree to the title, though he quickly gave in, and *American Imago* remains successful.

Freud was deeply concerned about the loss of his own journals printed in German, as well as the *Verlag*. He found a sympathetic and gifted writer, poet, and publisher, John Rodker, who founded the Imago Publishing Company (IPC) in London. Rodker’s co-directors were Barbara Low and Martin Freud, and the headquarters of the new company were located at 6,

Fitzroy Square in London. For a short time in 1939 a combined *Zeitschrift* and *Imago* were published in London, but failed to survive the beginning of the Second World War.

Plans had already been made for the publication of a new edition of Freud's collected works, and the *Gesammelte Werke* were published by the new company and replaced the original *Gesammelte Schriften*. Its eighteen volumes were undoubtedly a publishing triumph. Individual works by Freud were also published by the IPC in German, of which *Aus den Anfängen der Psychoanalyse* (later translated as *The Origins of Psycho-Analysis* (1954) by Eric Mosbacher and James Strachey and edited by Marie Bonaparte, Anna Freud and Ernst Kris) was of cardinal importance, containing as it did the most important letters to Fliess on the subject as well as relevant drafts and notes. Other major Freud works published by the IPC in English translation were *Three Essays of the Theory of Sexuality* (1905d), *The Question of Lay Analysis* (1926e), and *On Aphasia* (1891b). The publishing house also issued important works by other authors, of which *Twins: A Study of Three Pairs of Identical Twins* (1952) by Dorothy Burlingham is exemplary. Other publishing arrangements for psychoanalytic books were well established by the time the IPC closed, shortly after its last publication in 1962.

CLIFFORD YORKE

See also: *Gesammelte Werke*; Low, Barbara.

### Bibliography

- Burlingham, Dorothy. (1952). *Twins: A study of three pairs of identical twins*. London: Imago Publishing Co.
- Freud, Sigmund. (1954a). *The origins of psycho-analysis: Letters to Wilhelm Fliess, drafts and notes: 1887–1902*. (Marie Bonaparte, Anna Freud, and Ernst Kris, Eds.). London: Imago Publishing Co.
- Grubrich-Simitis Ilse. (1995). *Urbuch der Psychoanalyse. Hundert Jahre Studien über Hysterie von Josef Breuer und Sigmund Freud*. Frankfurt am Main: S. Fischer.

## IMAGO. ZEITSCHRIFT FÜR DIE ANWENDUNG DER PSYCHOANALYSE AUF DIE GEISTESWISSENSCHAFTEN

Following the launch of *Jahrbuch für Psychoanalyse* and *Zentralblatt für Psychoanalyse*, Hugo Heller, the

publisher, in 1921 created *Imago*, the third psychoanalytic periodical under the editorial direction of Sigmund Freud. While the two earlier publications were primarily oriented toward clinical applications and developments, *Imago* introduced an interdisciplinary approach to journal publishing, an approach that Freud had already tested with the series "Schriften zur angewandten Seelenkunde" (Essays on applied psychology), published by Franz Deuticke. With *Imago*, the concept was enlarged and expanded in periodical form.

The original title of the journal had been *Eros and Psyche*, but that was changed to *Imago*, after the name of a novel by Carl Spitteler (1845–1924). For Freud, the name was sufficiently vague to be useful to his enterprise (letter to Ernest Jones, January 14, 1912). Directed toward other than clinical ends, the journal served as a forum to introduce an experimental dialogue with neighboring fields such as anthropology, philosophy, literature, theology, and linguistics (see Freud, 1913j).

Consistent with this approach, the first part contains a contribution from two lay analysts, the editors-in-chief of the publication, Otto Rank and Hanns Sachs. This was "Entwicklung und Ansprüche der Psychoanalyse" (Development and demands of psychoanalysis), in which the authors show that the methodology of psychoanalysis, although based on concrete methods of therapy, continued to struggle, in its theoretical paradigms, with the relation between dreams and artistic, mythological, and religious fantasies. Consequently, it was necessary to test and develop the knowledge obtained through the study of dreams, neuroses, and symptom formation as part of a general science of the mind based on the unconscious. *Imago* was not only addressed to nonmedical lay practitioners but actively courted this target group in search of authors, thereby exposing psychoanalysis to areas of expertise outside therapy.

A number of Freud's contributions to applied psychoanalysis appeared in *Imago*, ranging from excerpts from *Totem and Taboo* in 1912 to early manuscript versions of *Moses and Monotheism*, which appeared in the final volume, published in Vienna in 1937.

The periodical was the product of a flourishing publishing business. Its success was based not only on the quality of content but also the number of readers. Following its transfer to the Internationaler

Psychoanalytischer Verlag (International Psychoanalytic Press), it was the largest source of income for the publisher. After the seizure of the Internationaler Psychoanalytischer Verlag by the National Socialists in 1938, Anna Freud and other émigré analysts succeeded in continuing publication of *Imago* until 1941, when it merged with the *Internationale Zeitschrift für Psychanalyse*.

In 1939 Hanns Sachs, seeking to perpetuate the *Imago* tradition in the United States, founded *American Imago*, which still exists. After the Second World War a number of psychoanalytic periodicals followed in the tradition of an interdisciplinary psychoanalytic journal, first introduced by *Imago*.

LYDIA MARINELLI

*See also:* *American Imago*; Applied psychoanalysis and the interaction of psychoanalysis; First World War: The effect on the development of psychoanalysis; Heller, Hugo; Imago Publishing Company; *Internationale Zeitschrift für (ärztliche) Psychoanalyse*; Internationaler Psychoanalytischer Verlag; Rank (Rosenfeld), Otto; Sachs, Hanns.

### **Bibliography**

Freud, Sigmund. (1913j). The claims of psycho-analysis to scientific interest. *SE*, 13: 165.

Freud, Sigmund, and Abraham, Karl. (1965). *A psychoanalytic dialogue: The letters of Sigmund Freud and Karl Abraham, 1907–1926* (Hilda C. Abraham and Ernst L. Freud, Eds.). New York: Basic Books.

Freud, Sigmund, and Binswanger, Ludwig. (2003). *The Sigmund Freud–Ludwig Binswanger correspondence, 1908–1938* (Gerhard Fichtner, Ed.). New York: Other Press.

Freud, Sigmund, and Jones, Ernest. (1993). *The complete correspondence of Sigmund Freud and Ernest Jones, 1908–1939* (R. Andrew Paskauskas, Ed.). Cambridge, MA: Harvard University Press.

---

## **IMPOSTER**

Psychoanalytic tradition considers the nature of the imposter by referring to the work of Karl Abraham originally; during the 1950s, to the work of Helene Deutsch; and later to Phyllis Greenacre.

Their work contained descriptions of clinical cases as well as a comparison of famous imposters throughout history, like James MacPherson. The imposter is someone who pretends to be someone they are not. It

is the falsification of identity that creates the imposture, the borrowed identity being that of someone else or that of an imaginary person with a different name or a different profession. The success of the imposture may depend on the complicity of others in the lie.

In truth none of the descriptions given in the literature goes much further than these relatively superficial findings. The attempt to create a composite picture of the imposter has failed because of the inaccuracy of the term itself, which is not conceptual, and the diverse personalities included under this term.

However, several characteristics have been advanced as being specific to the imposter. These include the compulsion to enact the family romance, disorders in the sense of identity (which are paradoxically relieved by the borrowed identity), and a malformed superego. Considered as a form of psychopathology, imposture has been classified among the perversions. Imposters are described as having usurped the role of the oedipal father and as identifying with the maternal phallus at an early age.

ANDRÉE BAUDUIN

*See also:* As if personality.

### **Bibliography**

Deutsch, Helene. (1955). The impostor: Contribution to ego psychology of a type of psychopath. *Psychoanalytic Quarterly*, 24, 483–505.

Greenacre, Phyllis. (1958). Early physical determinants in the development of the sense of identity. *Journal of the American Psychoanalytic Association*, 6, 612–627.

---

## **IMPULSE.** *See* Drive/instinct

---

## **INCEST**

Characterization and definitions vary across cultures, but incest refers to sexual relations between close relatives. Prohibition may be according to custom or morality, and embodied in law. In psychoanalysis, the term

is also and especially discussed in terms of fantasy and psychological conflict.

Freud mentioned incest for the first time in his correspondence with Wilhelm Fliess (Draft N, dated May 31, 1897), in which he explained “saintliness” in terms of its impious and anti-social character (1950a). A family primordially promiscuous would be forced to give up incestuous behavior in order to avoid being socially isolated.

Incest subsequently became a central theme in Freud’s formulation of the Oedipus complex, defined as a child’s conflict between sexual desire for the parent of the opposite sex (the “positive” oedipal complex) and repression of that desire. The theory was put forth in *Three Essays on the Theory of Sexuality* (1905d) and in Freud’s discussion of the case of “Little Hans” (1909b), among other works.

From the start Freud also discussed the incest taboo in an anthropological context, in terms of its role in the evolution of society. The first chapter of *Totem and Taboo* (1912–13a) was devoted to “the horror of incest” and was based on the work of contemporary ethnologists. For Freud it was important to establish that such a taboo operated in every human society. This view gained some support in the work of later anthropologists, including Claude Lévi-Strauss, who, however, maintained reservations regarding Freud’s obligatory corollary, that the Oedipus complex was “universal.” (See André Green [1995] for a discussion of Lévi-Strauss’s views.)

Freud held that psychic energy which accumulates through repression of sexual gratification, prohibitions owed to the oedipal situation, becomes an essential force propelling the development of civilization, especially through channels of sublimation. In “‘Civilized’ Sexual Morality and Modern Nervous Illness” (1908d), Freud suggested that repression can also provoke psychological disorders through the “damming-up” of libido (the “actual” neuroses) or by substitute symptom formation (the psychoneuroses). The price of civilized morality is high when repression adversely affects too many individuals and distorts the social fabric; Freud examined these issues in *Group Psychology and the Analysis of the Ego* (1921c) and in *Civilization and Its Discontents* (1930a).

The incest theme has received little attention in contemporary psychoanalytic literature; an exception

is Paul-Claude Racamier’s interesting treatment of the “incestual” (1995).

ROGER PERRON

*See also:* Ethics; Family romance; Framework of the psychoanalytic treatment; Law and psychoanalysis; Myth of origins; Oedipus complex; Phantom; Privation; Prohibition; *Psychology of the Unconscious, The Secret*; “Some Psychical Consequences of the Anatomical Distinction Between the Sexes”; Tenderness; *Totem and Taboo*; Transgression.

### Bibliography

- Freud, Sigmund. (1905d). Three essays on the theory of sexuality. *SE*, 7: 123–243.
- . (1909b). Analysis of a phobia in a five-year-old boy. *SE*, 10: 1–149.
- . (1921c). Group psychology and the analysis of the ego. *SE*, 18: 65–143.
- . (1908d). “Civilized” sexual morality and modern nervous illness. *SE*, 9: 177–204.
- . (1912–13a). Totem and taboo. *SE*, 13: 1–161.
- . (1930a). Civilization and its discontents. *SE*, 21: 57–145.
- . (1950a [1897]). Draft N. “Impulses, fantasies and symptoms.” *SE*, 1: 173–280.
- Green, André. (1995). *La Casualité psychique*. Paris: Odile Jacob. *Propédeutique. La métapsychologie revisitée*. Paris: l’Or d’Atalante.
- Racamier, Paul-Claude. (1995). *L’inceste et l’incestuel*. Paris: Éditions du Collège de psychanalyse groupale et familiale.

### Further Reading

- Simon, Bennett. (1992). Incest—see under “oedipus complex”: the history of an error in psychoanalysis. *Journal of the American Psychoanalytic Association*, 40, 955–988.
- Simon, Bennett, and Bullock, Christopher. (1994). Incest and psychoanalysis: Are we ready to fully acknowledge, bear and understand? *Journal of the American Psychoanalytic Association*, 42, 1261–1282.

---

## INCOMPLETENESS

In psychoanalysis, the state of “incompleteness” does not connote an imperfect or unfinished state, but rather implies openness and retrospective reexamination.

The notion of incompleteness in the work of Sigmund Freud presupposes two possibilities and one constraint: the integration of new ideas and the reexamination of old ideas in retrospect, provided that the whole remains coherent.

The image of the umbilical knot used by Freud in connection with dreams in *The Interpretation of Dreams* (1900a) to represent the unfathomable reaches that are endlessly saturable with meaning—the ego’s vanishing point—eventually found its homologue in the realm of reality in Heisenberg’s uncertainty principle. Some form of incompleteness can be deduced from the integration of the new, from the working of deferred action, from demands for the production of coherence; it is a relationship that can be located in psychoanalytic theory, clinical practice, and treatment.

Incompleteness in the realm of theory can be pinpointed, in terms both of Freud’s mental moves leading to theoretical creation and of the content of his theories. Several authors, such as Didier Anzieu, Jean Guillaumin, and Jean-Paul Valabrega, have established parallels between certain of Freud’s personal mental changes and his great moments of theoretical creation: “Project for a Scientific Psychology” (1950c [1895]); the writings included in the *Metapsychology* of 1915; the turning point of 1920, when dualism of the instincts was introduced into the corpus; and the years 1937–1938, when the theory of trauma from the “Project for a Scientific Psychology” was revised to make it coherent with the apparatus of the second topography, to cite only a few.

In 1895 Freud was already well advanced in his theoretical conception of neurosis, particularly hysteria. Under a certain amount of pressure from his colleagues, notably Wilhelm Fliess, who was formulating his own theory of the “periods,” Freud found himself urgently in need of a homogeneous, totalizing formulation of psychic mechanisms that would take into account the theory of the neuroses and the normal psychic apparatus—hence his haste in writing “Project for a Scientific Psychology.” This essay brings with it a paradox that attests to Freud’s felicitous inability to conceptualize a closed theoretical system: Based on the neurological metaphor, he provided a coherent and relatively finished system that he nonetheless called a “Project” in the sense of a sketch (*Entwurf*). History showed that this was indeed just a sketch, whose hypercoherence was dismantled beginning in September 1897—at the same time as Freud’s work of mourning

in connection with the death of his father—and whose elements were reworked and used in subsequent theoretical developments.

Thereafter, Freud no longer allowed himself to be dominated by the desire to devise a system that would have an answer for everything. The topography, as well as his theories of anxiety, the instincts, and the neuroses, was modified in light of his clinical work, leading to new theoretical acquisitions such as the “splitting of the ego in the process of defense,” for example.

As the foundations of the psychic apparatus, the instincts were a theoretical constant that was given even greater emphasis with the introduction of the id in the second topography. Principles and laws of psychic functioning came to modulate and use, to the benefit of ideation and meaning, the power that is inseparable from the notion of the instinct. This force can meet with two economic vicissitudes: “binding” and “discharge.” Above all, after the metapsychological complexification of the second topography, a balance between binding and discharge was imposed, even if Freud more particularly indicated the path of binding culminating in the construction of more and more representational units that can be subjectivized. After 1920, and mainly after 1923–1924, around the time of “The Ego and the Id” (1923b), the first trauma-based theories of 1895 were reworked so that the notion of trauma could be integrated and become a constituent part of the *Metapsychology*. Not only is there a traumatic kernel in neurosis, but the id, even in its normal state, is traumatic for the ego.

The relations of the instincts and the other psychic contents (ideas) are marked by incompleteness. The incompleteness of the fabric of representation and the inexhaustible nature of the quest for meaning and coherence attest to the fact that the relations between the psychic agencies and objects satisfy a complex dynamic, which Freud’s successors attempted to theorize.

Incompleteness is at the heart of psychoanalytic practice. Freud refused to reduce the scope of psychoanalysis to that of psychotherapy. To be sure, there are the symptoms and suffering of patients, but analysis opens up other horizons, as Freud unambiguously declared in the “New Introductory Lectures on Psycho-Analysis” (1933a [1932]): “I did not want to commend [psychoanalysis] to your interest as a



method of treatment but on account of the information it gives us about what concerns human beings most of all—their own nature” (pp. 156–157).

From its own unfathomability to the multiplicity of its exterior, the subject is constantly being transformed. The essential question of psychoanalysis has become that of subjectivity, which today has plunged it into a paradoxical situation. Without doubt, Freud left it to his successors to establish a theory of the subject. They have not yet managed to construct one that would be coherent with Freudian metapsychology, and most often we must content ourselves with invoking what Raymond Cahn has called the “process of subjectivation.” This places the emphasis on interpretative intent in psychoanalysis, whose essential aim is no longer simply bringing material into consciousness, but also to enable a constant reworking, through discourse, of the representations and formations of desire, identifications, and affect-fixating memories upon which the analysand writes and rewrites their history. “Where id is, there ego shall be” (1933a [1932], p. 80). Rather than seeing in this the idealistic aim of a Freud limited by a psychotherapeutic ideal, we can infer the modesty of Freud, the psychoanalyst, revealing the magnitude of the analyst’s clinical task. It is not the completion of this task, even supposing that would be possible, that would trigger the process of the end of treatment, but perhaps the ability to work through the grieving process it entails.

Whether the emphasis is placed on the subject’s coming into being or on subjectivation, this presupposes the corollary idea of maintaining that entity, which requires that it make constant adjustments in relation to the agencies, its ideals, and others. Considering the power of the drives, the state of the subject is precarious, always susceptible of dissolving into actions or symptoms, especially when it is a question of seeking out, through transference, “truths” and new insights, as analysis according to Freud proposes to do. The quest for truth and the quest for causality, moved by the power of the drives, endow the very process of subjectivation with its unstable and ever incomplete character.

The completion and incompleteness of analysis preoccupied Freud until the end of his work, as his “Analysis Terminable and Interminable” (1937c) attests. Today, the idea of a completed analysis is entirely relative, and opinion remains divided as to the criteria for ending treatment. Respect for the idea of

incompleteness bears with its full weight on the ethics of the psychoanalyst as one of the elements that protects the treatment from the alienation that would result if the analyst were to impose their own desire upon that of the analysand.

RENÉ PÉRAN

*See also:* Indications and contraindications for psychoanalysis for an adult.

### **Bibliography**

- Cahn, Raymond. (1997). Le processus de subjectivation à l'adolescence. In M. Perret Catipovic, and F. Ladame (Eds.), *Adolescence et psychanalyse: une histoire* (pp. 213–227). Lausanne, France: Delachaux et Niestlé.
- Freud, Sigmund. (1900a). The interpretation of dreams. Part I, *SE*, 4: 1–338; Part II, *SE*, 5: 339–625.
- . (1933a [1932]). New introductory lectures on psycho-analysis. *SE*, 22: 1–182.
- . (1937c). Analysis terminable and interminable. *SE*, 23: 209–253.
- . (1950c [1895]). Project for a scientific psychology. *SE*, 1: 281–387.

---

## **L'INCONSCIENT**

The periodical, *L'Inconscient*, was founded by Piera Aulagnier-Spaurani, who was the editor-in-chief, and Jean Clavreul and Conrad Stein. With the help of Renée Andrau and Lucio Covello as editorial secretaries, the first issue, published by Presses Universitaires de France, appeared in January–March 1967. At the time the psychoanalytic movement in France had been wracked by divisions and internal dissension. The Société Française de Psychanalyse (French Psychoanalytic Society) had been dissolved and rival institutions created. These included the Association Psychanalytique de France (French Psychoanalytic Association), which in 1965 became part of the International Psychoanalytic Association, and the École Freudienne de Paris (Freudian School of Paris), directed by Jacques Lacan. Two students of Lacan’s organization worked with a member of the Société Psychanalytique de Paris (Paris Psychoanalytic Society), Conrad Stein, to create a review that was open to the opposing points of view that were tearing the French psychoanalytic movement apart. It was one

of the attempts by psychoanalysts of the 1950s to establish connections with organizations other than the official psychoanalytic bodies, which pretended to ignore one another when they were not actively jockeying for position.

Appropriately, the first issue was devoted to the topic of “transgression,” and included essays by Conrad Stein, Serge Leclaire, Michel Neyraut, Guy Rosolato, and Piera Aulagnier. Other issues followed; the issue devoted to perversion contained contributions from Jean Clavreul, André Green, Jean-Paul Valabrega, and Georges Daumézon. Daumézon represented the symbolic link that united these disparate personalities: The Sainte-Anne Hospital, where many of these young psychoanalysts worked. (Most were between thirty and forty years of age at the time.)

Over the course of eight issues, there were contributions from a wide range of practitioners, including Serge Viderman, Lucien Israël, Irène Roublef, Christian David, Michel de M’Uzan, Francis Pasche, François Roustang, Jean-Luc Donnet, François Perrier, Jean Gillibert, Joyce McDougall, Dominique Geachan, Claude Robant, Robert Barande, and Cornélius Costoriadis. Unfortunately, dissension within the psychoanalytic community led to the cessation of publication after two years. The final issue, of October 1968, was devoted to the potentially explosive topic of psychoanalytic training. The founders argued among themselves, a reflection of the dissension within the Lacanian movement that had originated with Lacan’s statements concerning “*la passe*” in October of the previous year. A notice indicated that “the editors have been unable to agree on the direction most suitable for a review of psychoanalysis or on the role they felt it should play.”

Five months later Piera Aulagnier founded the Quatrième Group, Organisation Psychanalytique de Langue Française (Fourth Group: French Language Psychoanalytic Organization) with François Perrier and Jean-Paul Valabrega, and the review *Topique*. That same year, 1969, Conrad Stein founded *Études freudiennes*, which also published points of view that differed from the French psychoanalytic mainstream. It was several years, however, before the psychoanalytic ecumenicalism of *L’Inconscient* was repeated in France.

ALAIN DE MIJOLLA

See also: *Études freudiennes*; France; *Topique*.

## INDIA

The founder’s meeting of the Indian Psychoanalytic Society took place in Calcutta in 1922 with Girindra-shekhar Bose, a young Bengali doctor who had read the English translations of Freud’s work, in the chair. Of the fifteen original members, nine were college teachers of psychology or philosophy and five belonged to the medical corps of the Indian Army, including two British psychiatrists. In the same year, Bose wrote to Freud in Vienna. Freud was pleased that his ideas had spread to such a far-off land and asked Bose to write Ernest Jones, then President of the International Psychoanalytic Association, for membership of that body. Bose did so and the Indian Psychoanalytic Society, with Bose as its first president (a position he was to hold till his death in 1953) became a fully-fledged member of the international psychoanalytic community.

Cut off from the debate, controversy, and ferment of the psychoanalytic centers in Europe, and dependent upon often difficult to acquire books and journals for outside intellectual sustenance, Indian psychoanalysis was nurtured through its infancy primarily by the enthusiasm and intellectual passion of its progenitor. In the informal meetings of eight to ten people held on Saturday evenings at the president’s house—which was to become the headquarters of the Indian Society after Bose’s death—Bose read most of the papers and led almost all the discussions.

Although psychoanalysis attracted some academic and intellectual interest in the 1930s and 1940s, mostly in Calcutta, the number of analysts was still small (fifteen) when in 1945 a second training center, under the leadership of an Italian expatriate, Emilio Servadio, was started in Bombay.

To judge from the record of publications of its members, the small Indian society was fairly active up through the 1940s. There was a persistent concern with the illumination of Indian cultural phenomena as well as attempts to register the “Indian” aspects of the patients’ mental life. By the early 1950s, however, the interest in comparative and cultural aspects of mental life, as well as the freshness of the papers written by the pioneering generation of Indian psychoanalysts, was lost. Thereafter, most Indian contributions, to judge from the official journal of the Indian Society, have been neither particularly distinctive nor original.

In the public arena, psychoanalysis has generally had an indifferent, if not hostile, reception. At first glance, the Indian indifference to psychoanalysis seems surprising, given the fact that there has rarely been a civilization in human history that has concerned itself so persistently over the millennia with the nature of the “self” and with seeking answers to the question, “Who am I?” As a colonized people, however, reeling under the onslaught of a conquering European civilization that proclaimed its forms of knowledge and its political and social structures as self-evidently superior, Indian intellectuals in the early twentieth century felt the need to cling doggedly to at least a few distinctive Indian forms in order to maintain intact their civilization’s identity. The Indian concern with the “self,” its psycho-philosophical schools of “self-realization,” often appearing under the label of Indian metaphysics or “spirituality,” has become one of the primary ways of salvaging self-respect, even a means of affirming a superiority over a materialistic Western civilization. Psychoanalysis was seen to be a direct challenge to the Indian intellectual’s important source of self-respect; it stepped on a turf the Indian felt was uniquely his own.

Another reason for the rejection of Freudian concepts had to do with their origins. Derived from clinical experience with patients growing up in a cultural environment very different from that of India, some of the concepts, when transposed, did not carry much conviction. The different patterns of family life and the role of multiple caretakers in India seemed to push in the direction of modifications of psychoanalytical theory. Similarly, Freudian views of religion, derived from the Judeo-Christian monotheistic tradition, with its emphasis on a father-god, had little relevance for the Indian religious tradition of polytheism where mother-goddesses often constituted the deepest substratum of Indian religiosity.

Because of its relative isolation, Indian psychoanalysis has been decisively marked by the stamp of the first Indian analyst, Girindrashekar Bose (1886–1953). Without experiencing the benefits of training analysis himself, it was Bose who “analyzed” the other members in a more or less informal manner. He developed a method of his own, similar to the active therapy and forced fantasy method of Sándor Ferenczi, which calls for a more active, didactic stance from the analyst, and which came dangerously close to what a lawyer is forbidden to do in the courtroom, namely “lead the witness,” increasing the chances of

suggestion. In hindsight, Bose’s important contribution to psychoanalysis was less his “theory of opposite wishes” and more his questioning of some presumed psychoanalytic universals, based on his clinical experience. In his letters to Freud, Bose points out differences in the castration reactions of his Indian and European patients and notes that the desire to be a female is more easily unearthed in Indian male patients than in European. Since cultural relativism was not on the psychoanalytic agenda in the 1930s when Bose communicated his observations, they received little attention.

The question of cultural relativism versus the universality of many psychoanalytic concepts and theories is very much at the heart of contemporary analyst Sudhir Kakar’s work. Based on clinical and cultural data from India, Kakar has highlighted the cultural aspects of the psyche in his many books and papers, trying to show that mental representations of the culture play a significant role in psychic life.

The Indian Psychoanalytic Society has published a journal, *Samiksa, the Journal of the Indian Psychoanalytical Society*, since 1946.

SUDHIR KAHAR

### **Bibliography**

- Hartnack, Christiane. (1990). Vishnu on Freud’s desk: psychoanalysis in colonial India. *Social Research*, 57 (4), p. 921–949.
- Kakar, Sudhir. (1996). *Culture and psyche: Psychoanalysis and India*. New York: Psyche Press.
- Vaidyanathan, T.G. (1996). *Hinduism and psychoanalysis: A reader*. Delhi, Oxford University Press.

## **INDICATIONS AND CONTRAINDICATIONS FOR PSYCHOANALYSIS FOR AN ADULT**

Borrowed from traditional medicine, the notions of indications and contraindications have been very much present in the writings of Freud and his medical following from the very beginnings of psychoanalysis. Moreover, the indications and contraindications for psychoanalysis have changed in the course of theoretical and practical developments that have profoundly altered attitudes toward psychoanalytic treatment.

In *Studies on Hysteria* (1895d), Sigmund Freud and Josef Breuer listed certain conditions for applying the

cathartic method: “The procedure is not applicable at all below a certain level of intelligence. . . . The complete consent and complete attention of the patients are needed, but above all their confidence (1895d, p. 264). In “Freud’s Psycho-Analytic Procedure” (1904a [1903]), Freud specified further indications and contraindications: “Chronic cases of psychoneuroses without any very violent or dangerous symptoms are the most favourable ones for psycho-analysis: thus in the first place every species of obsessional neurosis, obsessive thinking and acting, and cases of hysteria in which phobias and abulias play the most important part; further, all somatic expressions of hysteria whenever they do not, as in anorexia, require the physician to attend promptly to the speedy removal of the symptoms. . . . The patient must be capable of a psychically normal condition; during periods of confusion or melancholic depression nothing can be accomplished even in cases of hysteria. . . . Deep-rooted malformations of character, traits of an actually degenerate constitution, show themselves during treatment as sources of a resistance that can scarcely be overcome. . . . If the patient’s age is in the neighbourhood of the fifties the conditions for psycho-analysis become unfavourable” (pp. 253–254).

Gradually, with the work of Karl Abraham, Ernst Simmel, and Wilhelm Reich, the range of cases regarded as appropriate for treatment expanded to include psychoses and borderline conditions, even perversions and drug addiction—with uneven results. As time went on, efforts were made to separate the issue of indications from medical categories and traditional diagnostic procedures, in order to create a suitable framework for understanding the metapsychological factors underlying the demand for treatment and a suitable framework allowing prediction of its results. Otto Fenichel (1945) included in his contraindications, in addition to advanced age and unfavorable life conditions, the “absence of a reasonable and cooperative ego” and the existence of significant secondary gains derived from symptoms.

In 1955 Edward Glover, discussing the “transference potential of the patient,” distinguished “accessible” cases (psychoneuroses, reactive depressions, psychosexual inhibitions, optional bisexuality) and “moderately accessible” cases (obsessional neurosis, fetishism, alcoholism and drug addiction, chronic maladaptation, psychopathic delinquency) from “rebel cases” (psychoses, grave character disorders, and sexual

disorders). The list presented by Sacha Nacht and Serge Lebovici in 1958 was fairly close to this one.

The issue of indications and contraindications has acquired another dimension with the notion of “analyzability,” especially after the Twenty-Fifth International Congress of Psychoanalysis (Copenhagen, July 1967) and René Diatkine’s 1968 article. Diatkine proposed evaluating the patient on first encounters to prognosticate the evolution of future treatment: evaluation of imaginative capacities, flexibility in object relations, screening for an “operational idea,” and so on. Subsequently, McDougall (1972) used the notion of the “anti-analysand” to characterize a patient who disassembles normalcy, sometimes as a cover for serious relational problems—a trait that poses a risk of making analysis impossible.

As a result of a growing interest in the role of the psychoanalyst’s counter-transference, whether psychoanalysis is indicated has come to mean considering the analyst’s particular capacities for empathy and tolerance for various kinds of pathologies in a candidate patient. In 1945 Otto Fenichel noted that analysis could be counterindicated with a given analyst for reasons other than the analyst’s sex or prior relationship with the candidate analysand. Robert Barande has also discussed “analyst indication.”

The expansion of the range of indications and the multiplication of approaches in psychoanalytic and related forms of psychotherapy has modified, sometimes in the direction of excessive laxity, decisions about whether analysis is appropriate. This proliferation has even been seen as a reason for the disappointment of those who expect miracles from a psychoanalytic approach to difficult cases.

Finally, it is appropriate to recall what Freud wrote to Ludwig Binswanger on May 28, 1911: “Truthfully, there is nothing that man’s organization makes him less apt for than psychoanalysis” (2003).

ALAIN DE MIJOLLA

*See also:* Analyzability; Congrès des psychanalystes de langue française des pays romans.

### **Bibliography**

Diatkine, René. (1969). L’enfant prépsychotique. *Psychiatrie de l’enfant*, 12, 2, 413–446.

- Fenichel, Otto. (1945). *The psychoanalytic theory of neurosis*. New York: W. W. Norton.
- Freud, Sigmund. (1904a [1903]). Freud's psycho-analytic procedure. *SE*, 7: 247–254.
- . (2003 [1908–1938]). *The Sigmund Freud–Ludwig Binswanger correspondence, 1908–1938* (Arnold J. Pomerans, Trans.). New York: Other Press.
- Freud, Sigmund, and Breuer, Josef. (1895d). Studies on hysteria. *SE*, 2: 48–106.
- Glover, Edward. (1955). *The technique of psychoanalysis*. London: Tindall and Cox.
- McDougall, Joyce. (1972). L'anti-analysant en analyse. *Revue Française de Psychanalyse*, 36, 167–206.
- . (1992). *Plea for a measure of abnormality*. New York: Brunner/Mazel. (Original work published 1978)
- Nacht, Sacha, and Lebovici, Serge. (1958). Indications et contre-indications de la psychanalyse chez l'adulte. In Sacha Nacht (Ed.), *Psychanalyse d'aujourd'hui*. Paris: Presses Universitaires de France.

### Further Reading

- Grand, Stanley. (1995). Classic revisited: Stone's "The widening scope of indications for psychoanalysis". *Journal of the American Psychoanalytic Association*, 43, 741–764.
- McNutt, Edith R. rep. (1992). Panel: Psychoanalysis and psychotherapy: indications, contraindications. *Journal of the American Psychoanalytic Association*, 40, 223–232.
- Stone, Leo. (1954). The widening scope of indications for psychoanalysis. *Journal of the American Psychoanalytic Association*, 2, 567–594.

## INDIVIDUAL

The concept of the individual is not especially Freudian, although analysis assumes that the analysand has a degree of psychic autonomy, individuality, and even identity. The term "individual" (*Einzel*) is found in Freud, notably in *Civilization and Its Discontents* (1930a [1929]), where it stands in opposition to culture. More broadly, the concept is central to a variety of disciplines, such as ethnology, sociology, political theory, and philosophy.

Cultural historians have described the birth of individual love as an outgrowth of courtly love, the appearance of the individual feeling of finitude and death at the end of the Middle Ages, and the birth of the modern conception of childhood within the family

in the eighteenth century (Philippe Ariès). With the Enlightenment and Romanticism, the child became "the father of the man." After 1900, childhood and adolescence became distinct age categories and stages of mental development. Scholars can trace the development of the concept of the individual across the political, social, cultural, and religious landscapes from the Renaissance to the Reformation to the Enlightenment.

While having universal scope, psychoanalysis is nonetheless marked with the imprint of Western culture, in which it was born. According to Claude Lévi-Strauss, this culture "vomits up" the individual, in contrast with group societies ("holistic" societies, according to Louis Dumont), which "swallow" the individual.

Ethnopsychanalysis (Georges Devereux) examines differences in mental development according to culture. The Oedipus complex described by Freud refers to the symbolic figure of the father in Jewish and Christian cultures, and it affords the possibility of triangulation, which leads to individuation and identity construction. Other oedipal modalities are present in matrilineal societies, where the parent is differentiated from the maternal uncle, who represents the paternal function—an arrangement consistent with limited individuality and extended dependence on the social group. The history of European culture is marked by a gradual transition from a holistic society (during the Middle Ages) to a society of individuals, and accompanying this transition was the evolution of identity formation characteristic of modernity.

If a conception of the individual is a precondition for the development of psychiatry, the existence of the self, the subject, is a precondition for the creation of psychoanalysis. When the individual perceives his ego as a double and perceives the uncanny nature of his division, this perspective can be presented as a cure for the suffering that the individual experiences in the face of modernity. In *Totem and Taboo* (1912–1913a), Freud hypothesized that a "mass psychosis," a collective soul, in his text, "culture" (*Kultur*) in the sense of a collective mental formation situated above the individual, to a large extent conditions the individual's mental functioning. Freud elaborated the concepts of the ego ideal and superego, transitional formations located between culture and the individual. He also showed that the repression associated with anality in

modern culture has an impact on the modalities of identity formation during adolescence.

During the 1950s Margaret Mahler defined “individuation” as a process of separation to escape the primary union of the mother-child symbiosis. Working with the uncertainties of individuation in infantile psychosis, Mahler described a “symbiotic” stage of child development, prior to the separation and individuation that ends absolute dependence. John Bowlby, using an ethological approach to the mental development of the infant, developed the concepts of attachment and separation. José Bleger, employing the concepts of symbiosis and ambiguity, showed that traces of primitive undifferentiation persist, even among the most evolved individuals, in the form of an “agglutinated nucleus.”

Research by Alain de Mijolla (1981) and data from group psychoanalysis and family therapy have shown connections between subjectivity and the Other in culture, in the family, and across generations, that is, connections among the intrasubjective, intersubjective, and intergenerational dimensions of the psyché.

HENRI VERMOREL

*See also:* Adolescence; Castration complex; Constitution; I; Identity; Libidinal development; Object; Processes of development; Self-consciousness; Self (true/false); Symbiosis/symbiotic relation.

### Bibliography

- Ariès, Philippe. (1962). *Centuries of childhood: A social history of family life* (Robert Baldick, Trans.). New York: Vintage Books. (Original work published 1960)
- Bleger, José. (1981). *Symbiose et ambiguïté: Étude psychanalytique* (A. Morvan, Trans.). Paris: Presses Universitaires de France. (Original work published 1967)
- Dumont, Louis. (1986). *Essays on individualism: Modern ideology in anthropological perspective*. Chicago: University of Chicago Press. (Original work published 1983)
- Freud, Sigmund. (1912–1913a). Totem and taboo. *SE*, 13: 1–161.
- . (1930a [1929]). Civilization and its discontents. *SE*, 21: 57–145.
- Mijolla, Alain de. (1981). *Les Visiteurs du moi: Fantômes d'identification, confluent psychanalytiques*. Paris: Belles Lettres.

## INDIVIDUATION (ANALYTICAL PSYCHOLOGY)

Carl Gustav Jung considered individuation to be a step or process that leads to a partial disengagement from the control of the unconscious and from collective rules and norms and feelings. This process is accompanied by a development of the rapport of the ego to the self, through an ever closer recognition of the forces and figures that structure—at first without our being aware of it—our representations and behavior.

The earliest version of this notion can be found in Gérard Dorn, in the sixteenth century, then in the Goethean conception of the novel of apprenticeship (*Bildungsroman*), as well as in the works of Arthur Schopenhauer and Friedrich Nietzsche. However, in his writings of the second decade of the twentieth century, Jung gave it a whole different meaning and significance, inscribing it into his own experience, then integrating it with the successive stages of his thought on the relationship with the unconscious.

Jung mentions individuation for the first time in 1916 in his *Seven Sermons to the Dead* and in an essay entitled “Adaptation, Individuation and Collectivity.” In the first of these, the emphasis was on the imperious need for everyone to undo the obscure envelope of their origin, distinguishing and differentiating themselves from it, to learn how to live as a unique being, separate and alone (“*einzelsein*,” he wrote). In the second work he stressed the debt contracted and the price to pay by anyone who distances themselves from the common knowledge and collective norms of a group.

These works showed the impact of Jung’s own experience on his work after the break with Freud (during the period of 1912–1918). His experience led to the emergence of images that, under the influence of the emotions he was feeling, gradually took on voice and shape: individuation for him was not only a necessity and a principle, on the basis of which a human being is constituted in his singularity, it is also a work—Jung soon was to call it a process (*ein Prozess*), and even a work of long duration (the ancient alchemists, whom he studied from 1935–1936, referred to it as their *opus*)—which one can learn to accompany, support, and even provoke.

From one phase of his work to another, Jung was always very specific about the stakes and the risks (of exaltation, or inversely, of depression, or even psychotic

breakdown) of individuation, as well as its modalities, notably in the clinical conditions of analytic practice, and its effects, possible or anticipated, on the future of man and on that of the unconscious itself.

In 1918, he started working on some empirical exercises in graphics that made him experience a decentralization, which he later realized was close to that produced by the use of mandalas, as well as the destabilization of the ego produced by Taoism. His reflections on the conditions of symbolic life for us today came from these studies, and also from his later analyses of the history of Christianity and his encounters with Amerindian and African religions. This includes his conception, a rather fluid one, of the self in its relations with the ego: what is at stake presently in individuation can be all the more clearly grasped as one becomes aware of its projections in ancient systems of representation and practice.

Also, from his publication of *The Relations between the Ego and the Unconscious*, in 1928, and with the help of his analyses of alchemical literature and iconography, Jung explored the diverse stages that mark the individuation process: recognition of “the shadow” or “shadows” proper to each, the more or less upsetting or mediating effects of “the anima” or “the animus,” and especially the experience of the “Self.”

Finally it should be noted that the Jungian reflection on individuation was part of a frequenting of the unconscious that constantly assumed its compensatory capabilities and its capacity to maintain conjoined contradictory attitudes and even givens. From this perspective the quaternary model of psychic functioning that he introduced in his *Psychological Types* (1921) was deepened and enlarged in the forties and fifties to apply to the analysis of opposing movements (in the direction of incest and inversely towards differentiation) that are stirred by the transference, expanding also to include a reflection on the conditions for an integration of the feminine, and on the question of evil.

Consequently, the Jungian problematic of individuation has provided access to and perspective on certain collective issues, but its pertinence for cultures with a different history this is unknown.

CHRISTIAN GAILLARD

See also: Analytical psychology; Compensation (analytical psychology); Ego (analytical psychology); Extrover-

sion/introversion (analytical psychology); Self (analytical psychology); Transference/counter-transference (analytical psychology).

### Bibliography

- Gaillard, Christian. (1995). *Jung*. Paris: Presses Universitaires de France.
- Humbert, Élie George. (1983). *Jung*. Paris: Éditions Universitaires.
- Jacoby, Mario. (1990). *Individuation and narcissism: The psychology of the self in Jung and Kohut* (Myron Gubitz, and, in collaboration with the author, Françoise O’Kane, Trans). London: Routledge. (Original work published 1985)
- Kast, Verena. (1992). *The dynamics of symbols: Fundamentals of Jungian psychotherapy* (Susan A. Schwarz, Trans.). New York: Fromm International. (Original work published 1990)

---

**INERTIA.** See *Principle of inertia*

---

### INFANS

The Latin term *infans*, derived from the Greek *phèmi* (“I speak”), means “one who does not (or rather, not yet) speak,” and refers to the baby before the acquisition of speech that marks the entry into childhood.

A number of authors (notably Melanie Klein and Donald Winnicott) used the term to describe those whose mode of communication is situated at a preverbal level. In the work of Jacques Lacan the term *infans* took on a further dimension in his discussion of language and its relation to the unconscious. Piera Aulagnier elaborated a theory of the mother-infant relation in terms of discourse (with the mother as “word-bearer”). The discussion here will be limited to the specific reference to language implied in the notion of *infans*.

In French translations of authors like Klein or Winnicott, terms such as *bébé* (baby), *nourrisson* (nursling), *petit enfant* (small/young child), or *infans* are used. A good many of Klein’s texts were originally written in German, and she used the word *infans*, which was translated in different ways in English and then in French, according to Luis E. Prado de Oliveira.

Winnicott commented on the term *infant*, commonly used in English, in “The Theory of the Parent-Infant Relationship,” originally published in the *International Journal of Psychoanalysis* in 1960. He explicitly referred to the fact that the infant does not yet have the use of verbal symbols or word-presentations. The baby’s dependence on the mother’s care is therefore more linked to maternal empathy than to any understanding the mother might have of what could be verbally expressed. In the work of Lacan, the “*infans* stage” precedes the advent of the subject through language. In “The Mirror Stage as Formative of the Function of the *I* As Revealed in Psychoanalytic Experience” (1949/2004), he wrote: “The jubilant assumption of his specular image by the kind of being—still trapped in his motor impotence and nursling dependence—the little man at the *infans* stage thus seems to me to manifest in an exemplary situation the symbolic matrix in which the *I* is precipitated in a primordial form, prior to being objectified in the dialectic of identification with the other, and before language restores to it, in the universal, its function as subject” (p. 4).

Piera Aulagnier’s theory of the *infans* stage is original in that she did not stop herself with merely noting the preverbal relationship to the mother at this stage, but also emphasizes that the mother plays the role of “word-bearer” in relation to the preverbal infant. This can be understood only in the context of the anticipation of the baby’s *I* by the mother. In *The Violence of Interpretation: From Pictogram to Statement* (1975/2001), Aulagnier writes: “The mother’s words and deeds always anticipate what the infant may know of them” (p. 10).

The idea of the mother as word-bearer draws on Lacan’s emphasis on the function of discourse. In *The Violence of Interpretation*, Aulagnier reminded us that “Every subject is born into a ‘speaking space’” and that the *I* is “an agency constituted by discourse” (p. 71). By “bearing” the word, the mother effects a twofold junction: first, between the infant’s manifestations and the outside world, by verbalizing them and giving them meaning; and second, between the world and the infant, since for the baby she serves as the representative of an external order, whose laws and demands she articulates.

Unlike the bodily needs that the newborn, because of its immaturity, cannot meet by itself, the psychic needs involving representation in its primal form (the pictogram) do not depend on intervention by a third

party. But the infant does not yet have access to the formation of ideas and naming, and it is thus in this place of lack that the mother as word-bearer is inserted. She fashions the objects that are presented to the infant by endowing them with a libidinal meaning. In Aulagnier’s words: “[F]or the senselessness of a real that could have no status in the psyche, it substitutes a reality that is human because it is cathected by the maternal libido, a reality that may be reshaped by the primal and the primary only because of that earlier work” (p. 74).

On this point, which is crucial for thinking the relationship with the world, and which marks the way in which that relationship depends on the relationship to the other—here the mother—Aulagnier simultaneously underscores her indebtedness to Lacan and her proximity to Wilfred Bion, from whom she considered herself to be fairly distant in other respects. With regard to Lacan, she notes: “The contribution of Lacan’s theory will be recognized here: indeed it might be said that the object is capable of being metabolized by the infant’s psychical activity only if, and as such, the mother’s discourse has endowed it with a meaning as evidenced by her naming of it. In this sense ‘swallowed’ with the object, Lacan was to see the primal introjection of a signifier as the inscription of a unary trait (*trait unaire*)” (p. 73).

As for Bion, she underscored her similarity to him as regarding the idea of an object that initially resided in the “maternal zone” and is then metabolized by the infant into a pure representation of its own relationship to the world. On the other hand, she diverged from both Lacan and Bion in her analysis of the consequences of this prosthetic function of the mother’s psyche in terms of “violence.” In this respect, we can assume that this notion that, a priori, seems surprising in the context of mother-child relations, came from another source—specifically, from the other violence that marks the bonds between the mother and the baby who will become psychotic, and specifically the schizophrenic.

In what sense does the mother/word-bearer inflict violence upon the *infans*? This necessary, “primary” violence is violence nonetheless, in that the infant feels the imposition of the word-bearer’s interpretations of the world. As Aulagnier explained in another work, the mother maintains a “spoken shadow” relationship with the infant, but the infant never completely coincides with this shadow that preexists it. The “violence”



is linked to the need to create and hold a subject-place (the spoken shadow) where there are as yet only potentialities. Accordingly, the future subject, the I, will come into being in a space preformed by expectations that are not its own. This is the necessary violence of maternal interpretation. But just as there is no such thing as a developmental *tabula rasa*, there can be no human subject without this pre-form. It is the discrepancy between the infant and shadow that makes it possible to situate a violence that will only really be violent (secondary violence) if the mother imposes it no longer upon the infant, but upon the I of the child.

SOPHIE DE MIJOLLA-MELLOR

*See also:* *Apprenti-historien et le maître-sorcier (L'-)* [The apprentice historian and the master sorcerer]; Controversial Discussions; Demand; Graph of Desire; Helplessness; I; Ideational representation; Identificatory project; Infant development; Megalomania; Narcissism; Object; Other, the; Primary narcissism; Sense/nonsense; *Violence of Interpretation, The: From Pictogram to Statement.*

### Bibliography

Castoriadis-Aulagnier, Piera (2001). *The violence of interpretation: From pictogram to statement.* (Alan Sheridan, Trans.).. Hove, U.K., and Philadelphia: Brunner/Routledge. (Original work published 1975)

Aulagnier, Piera. (1984). *L'Apprenti-historien et le maître sorcier. Du discours identifiant au discours délirant.* Paris: Presses Universitaires de France.

Lacan, Jacques. (2004). The mirror stage as formative of the function of the I as revealed in psychoanalytic experience. In his *Écrits: A selection* (Bruce Fink, Trans.).. New York: W. W. Norton (Original work published 1949).

Mijolla-Mellor, Sophie de. (1998). *Penser la psychose: Une lecture de l'oeuvre de Piera Aulagnier.* Paris: Dunod.

Winnicott, Donald W. (1960). The theory of the parent-infant relationship. *International Journal of Psycho-Analysis*, 41 (6), 585–595.

———. (1965). *The maturational processes and the facilitating environment.* London: Hogarth.

## INFANT DEVELOPMENT

The term *infant development* refers to the processes of psychic organization and transformation that lead the preverbal infant from absolute dependency to the

earliest integrations of the ego during the first year of life.

By studying the “psychical apparatus” in its structures, functioning, and development, Sigmund Freud established facts and proposed hypotheses that are indispensable to the study of early development. Freud’s newborn is a being in a state of helplessness (*Hilflosigkeit*) whose development requires that a “mutual understanding” be established between it and its mother, as he explained in “Project for a Scientific Psychology” (1950 [1895]). The infant is active, driven by needs that give rise to the hallucination of satisfaction, which, according to *The Interpretation of Dreams* (1900a), is the prelude to fantasies and thoughts. Its oral component-instincts trigger the fundamental mechanisms of projection and introjection, as described in “Three Essays on the Theory of Sexuality” (1905d) and “Negation” (1925h). These mechanisms gradually enable the infant to form an idea of its mother as a total object; it can then bind its autoerotism to the love-object, as described in “Three Essays on the Theory of Sexuality.” The parents’ narcissistic investment in the infant, described in “On Narcissism: An Introduction” (1914d), and the quality of the primary identifications that unite the baby with its parents, described in “The Ego and the Id” (1923), are the basis for its own “life and death narcissism,” to borrow André Green’s expression.

The earliest psychoanalytic writings on the psychic life of infants came from Melanie Klein (1933), Anna Freud (1946), Donald Winnicott (1945), René Spitz (1945), and John Bowlby (1951). From the beginning, the quality of interrelations between mother-environment and the infant was universally accepted as being a vital necessity, indispensable to human psychic and somatic development. Early work in the field produced such landmark concepts as “early organizers,” “prototypes of ego-defense,” “archaic forms of communication” (Spitz); “tonic dialogues” (Julian de Ajuriaguerra); “interactional epigenesis” (Erik Erikson); and “interactive spiral” (Serge Lebovici).

Over time, Freud’s basic theories were further elaborated. Thus the conception of the oral instinct’s analysis on the alimentary function was broadened to include sensory, affective, and object forms of nourishment. The theory of an attachment instinct (John Bowlby) took into account the needs for contact that play a major role at birth and in the evolution of the separation-individuation process in the young infant

(Mary Ainsworth, Margaret Mahler). The notion of stages (Freud, Karl Abraham) was supplanted by that of “positions,” with its greater focus on the analysis of processes. Klein’s hypothesis of an ego that is active from birth, operating through projections and introjections, has been accepted and appears to be compatible with Freud’s theory of “primary identification with the parents” or fundamental narcissistic identification, set forth in “The Ego and the Id.” The infant’s access to a representation of the mother as total object and the prevalence of the depressive position over paranoid anxieties (Klein) precipitate the coming together of the ego.

Recent works on “adhesive identity,” the “psychic skin,” and the “skin-ego” (Esther Bick, Frances Tustin, Didier Anzieu) have brought new developments to these problematics. The theory of an early activation of the ego’s reflexive function has also opened a field for exploration. The advent of consciousness of self, termed the “mirror stage” by Jacques Lacan, is, in Winnicott’s view, a construction linked to “the mirror of the mother’s face and the family.” According to Winnicott, interiorization of the love-object enables the infant to find or create potential spaces for representation of the self and the outside world.

In another problematic, Daniel Stern described the evolution of different “senses of self” and explored the primitive forms of representations that result from the “interpersonal bond.” Wilfred Bion (1962) analyzed how, through the earliest projections and introjections, there immediately develops between mother and infant a process of thought, or reverie, that transforms the excitations that submerge the infant into “alpha elements.” The latter can be considered as proto-representations elaborated in the coalescence of “infant’s body” and “mother-environment” (Piera Castoriadis-Aulagnier, Monique Piñol-Douriez). They are the malleable foundations of psychic construction, and they undergo the transformations proper to the depressive position and later developments. Through maturation and interrelations, the “interactional epigenesis” leads the preverbal infant to love and to hate. At the end of the first year, the infant is ready to develop language, many of whose elements it already understands, and which it is beginning to babble.

Although Freud made joint use of “direct observation and regressive analysis” (1905d) as working methods, some psychoanalysts believe that direct observation reflects an objectifying scientism and that

because it is preverbal, the very young infant cannot be subjected to a psychoanalytic approach. Nevertheless, the theories elaborated on the basis of observation of early development can feed into psychoanalytic practice, theory, and research.

MONIQUE PIÑOL-DOURIEZ AND MAURICE DESPINOY

*See also:* Adhesive identification; Anaclisis/anaclitic; Anxiety; Archaic mother; Breastfeeding; Breast, good/bad object; Combined parent figure; Creativity; Depressive position; Early interactions; Eroticism, oral; Experience of satisfaction; Family; Good-enough mother; Handling; Helplessness; Holding; Identificatory project; Infantile omnipotence; Infant observation (therapeutic); Lack of differentiation; Maternal care; Maternal reverie; capacity for; Mirror stage; Narcissism, primary; Optical schema; Paranoid-schizoid position; Prematureness; Primal scene; Primary love; Primary object; Primary process/secondary process; Processes of development; Self-consciousness; Self (true/false); Stranger; Sucking/thumbsucking; Symbiosis/symbiotic relation; Thought-thinking apparatus; Transitional object; Transitional object, space; Transitional phenomena; Wish, hallucinatory satisfaction of a.

### Bibliography

- Bion, Wilfred R. (1962). *Learning from experience*. London: Heinemann Medical Books.
- Bowlby, John. (1951). *Maternal care and mental health*. Geneva: W.H.O. Monographs.
- Freud, Sigmund. (1900a). The interpretation of dreams, Parts I and II. *SE*, 4–5.
- . (1905d). Three essays on the theory of sexuality. *SE*, 7: 123–243.
- . (1914d). On narcissism: an introduction. *SE*, 14: 67–102.
- . (1925h). Negation. *SE*, 19: 233–239.
- Freud, Anna. (1946). *The psychoanalytic treatment of children*. London: Imago Publishing Co., Ltd.
- Klein, Melanie. (1933). The early development of conscience in the child. In S. Lorand (Ed.), *Psycho-analysis Today*. New York: Covici-Friede.
- . (1987). Some theoretical conclusions regarding the emotional life of the infant. In *The writings of Melanie Klein: Vol. 3. Envy and gratitude and others* (pp. 61–93). London: Hogarth. (Original work published 1952)
- Lebovici, Serge. (1983). *Le Nourisson, la Mère et le Psychanalyste*. Paris: Le Centurion.

Spitz, René A. (1945). Hospitalism: an inquiry into the genesis of psychiatric conditions in early childhood. *Psychoanalytic Study of the Child*, 1, 53–74

Winnicott, Donald W. (1945). Primitive emotional development. *International Journal of Psycho-Analysis*, 26.

### Further Reading

Tyson, Phyllis. (2002). The challenges of psychoanalytic developmental theory. *Journal of the American Psychoanalytic Association*, 50, 19–52.

Tyson, Phyllis, and Tyson, Robert. (1990). *Psychoanalytic theories of development: an integration*. New Haven/London: Yale University Press.

## INFANT OBSERVATION

Infant observation has long been considered an important training exercise for child psychotherapists and for psychoanalysts (Bick, 1964). This has led to certain theoretical developments commonly associated with the work of Esther Bick (1968, 1986).

Bick began this work in 1948, shortly after Melanie Klein had described the paranoid-schizoid position. In Klein's view of the paranoid-schizoid position, the ego has a primary sense of a boundary between itself and the external world. Bick described a variant of this process, in which boundary of the ego is not primary, but comes from the sensations arising from skin contact. Sufficient skin sensations are necessary to give the experience of a boundary.

One of the processes she noticed interpersonally was that the breaking of skin contact appeared to be experienced by the infant as a hole from which it could leak. She noticed the frequency with which infants become incontinent of excreta, as well as loosing tears from the eyes, and screams from the mouth. She believed she was watching just that process which Klein had described as the disintegration of the ego in the early stages after birth. The fragmentation takes the form of an experience of leaking into empty space.

Bick described various methods by which the infant seemed to operate to plug that leaky gap. It might grasp with the mouth so that literally the hole is filled. Alternatively the hands may grasp as the mouth does; or more distantly the eyes may become fixed upon a point of light or some discrete object, as if clinging like the clenched hands. In addition the infant may fix aurally upon sounds, including the sound of its own

crying. These processes of filling, grasping, fixing, and hanging on represent a method of completing a boundary. However, the mother's contact with the baby's skin remains the most potent, and perhaps natural, means of completing the boundary.

The theoretical ideas concerning the skin are related to the notion of the "skin egos" developed by Didier Anzieu (1985) and Pierre M. Turquet's "skin-my-neighbor" (1975).

Bick's view was that the boundary between ego and external world was first of all a phenomenon of the body ego, and specifically the skin. Also, it is not a given structure at the outset of life, but instead has to be achieved through the experience of the mother "giving" the infant a sense of being enveloped, through the mother's innate understanding of the baby's need for skin contact. Thus the primary object that stabilizes the ego is not Klein's good internal object internalized inside the ego boundaries, but is the ego boundary itself. The skin is thus a bodily component of the stability of the ego, and it is gained passively, at first, from the external object (mother).

Bick thought she was extending Klein's theories, by displaying a psychic level prior to and beneath Klein's paranoid-schizoid position. However, this has not been generally accepted.

ROBERT D. HINSELWOOD

*See also:* Adhesive identification; Child analysis; Good-enough mother; Infant observation (direct); Lebovici, Serge; Sindel Charles; Processes of development; Symbiosis/symbiotic relation.

### Bibliography

Bick, Esther. (1968). The experience of the skin in early object relations. *International Journal of Psycho-Analysis*, 49, 558–566.

———. (1986). Further considerations on the functioning of skin in early object relations: findings from infant observation integrated into child and adult analysis. *British Journal of Psychotherapy*, 2, 292–299.

Pérez-Sánchez, Manuel. (1990). *Baby observation*. Perth: Clunie Press.

### Further Reading

Bick, Esther. (1964). Notes on infant observation in psychoanalytic training. *International Journal of Psychoanalysis*, 45, 558–566.

Boyer, Diane, and Sorensen, Pamela. (1999). Tavistock model of infant observation in neonatal intensive. *Psychoanalytical Inquiry*, 19, 146–159.

Freud, Anna. (1953). Some remarks on infant observation. *Psychoanalytic Study of the Child*, 8, 9–19.

Spitz, Rene A. (1950). Relevancy of direct infant observation. *Psychoanalytic Study of the Child*, 5, 66–73.

## INFANT OBSERVATION (DIRECT)

The direct observation of babies is a way of learning about the developing human mind.

In “The Psychogenesis of a Case of Homosexuality in a Woman” (1920), Sigmund Freud stated that if direct observation were sufficient to provide us with information on the origins of human sexuality, he would not have bothered to write his books. Arguably, we observe nothing that we do not already know, and vision, although closely linked to the scopical instinct—the foremost tool of curiosity and inquiry—is not a productive way of investigating psychic reality. Nevertheless, his observation of Little Hans, related in “Analysis of a Phobia in a Five-Year-Old Boy” (1909), provided him with the essential elements of his theory of the libido and castration anxiety. He believed he was able to see directly in the child “these sexual impulses and these formations built by desire that we have such difficulty uncovering in the adult.” His observation of an eighteen-month-old child playing the *Fort!/Da!* game with a wooden reel, related in “Beyond the Pleasure Principle” (1920), by establishing the basis for his theory of the death instinct, played a role not only in his theorizations of narcissism, but also because it provided a paradigm for numerous currents of thought in child psychoanalysis.

Freud and Melanie Klein, working within different perspectives, encouraged their students to observe infants, but without making this a separate field of study. It was Donald Winnicott who, in “The Observation of Infants in a Set Situation” (1941), defined that field by envisioning infant observation as a “set situation” capable both of providing information about the infant carried by its mother and of establishing an authentic therapeutic relationship with the infant, working in a nonverbal mode. Winnicott proposed his own reading of Freud’s “game of *Fort!/Da!*” and helped us to see what distinguishes his interpretation from

pure behavioral observation. He analyzed the sequence of the baby’s behaviors in three stages: (a) hesitation, which he interpreted as a “sign of anxiety about something” and a symptom of a conflict between the infant’s desire and its interiorization of a threatening maternal imago; (b) then the expression of self-confidence—which is close to what he called “omnipotence.” In some cases, this phase can lead to the world of make-believe and shared play; and (c) the game of appearance/disappearance of the object, in which the infant, emerging from its depressive mood, expresses its ability to restore the object through the game.

Winnicott thus establishes a difference between the primitive processes, as they can be directly observed, and the deeper processes that are already a reconstruction and elaboration of the primitive processes, linked with experience of the environment. He made it possible to utilize direct infant observation to better understand psychic reality in the process of being constructed.

The postwar period, in which psychoanalysts were faced with the problem of early psychopathologies, renewed interest in observation. René Spitz and John Bowlby, borrowing their methods from genetic psychology and ethology respectively, proposed new developmental models focused on, respectively, the concept of organizers of the ego and attachment theory. An important research trend then developed, mainly in the United States, that interpreted the baby’s nonverbal behaviors as genuine mental acts. Her work informed by the theories both Klein and Wilfred Bion, the British investigator Esther Bick, in “Notes on Infant Observation in Psycho-Analytic Training” (1964), for her part upheld the idea that the infant’s mental life unfolds in a projective mode that must be contained by psychic structures that are sufficiently developed to support the emergence of the processes of introjection. Originally conceived as a contribution to the training of child psychotherapists and psychoanalysts, this method has been extended to other objectives: research on the beginnings of the infant’s mental and relational life, prevention and treatment techniques used in families and in various institutional settings (treatment and other centers for young children, nurseries, neonatal care services).

From an epistemological point of view, Didier Houzel (1997) underscored the difference between an ethological approach and observation that he characterized as psychoanalytical, which sticks to the

proposed framework both internally (coming as close as possible to the baby's somatopsychic experiences) and externally (type of contract established with the family, means used by the various parties to abide by or transgress the conditions, and finally the observer's capacity for empathy). Observation thus takes place in two stages: encounter with the subject, and the deferred working-over of transference and counter-transference material.

DRINA CANDILIS-HUISMAN

*See also:* Infant observation (therapeutic).

### **Bibliography**

- Bick, Esther. (1964). Notes on infant observation in psychoanalytic training. *International Journal of Psycho-Analysis*, 45, 558–566.
- Freud, Sigmund. (1909b). Analysis of a phobia in a five-year-old boy. *SE*, 10: 1–149.
- . (1920g). Beyond the pleasure principle. *SE*, 18: 1–64.
- . (1920a). The psychogenesis of a case of homosexuality in a woman. *SE*, 18: 145–172.
- Winnicott, Donald. (1941) The observation of infants in a set situation. *International Journal of Psycho-Analysis*, 22, 229–249.

## **INFANT OBSERVATION (THERAPEUTIC)**

The method of observing the infant in its family environment, from birth to age two, using the rigor of the analytic framework, was conceived by Esther Bick. The observer visits the infant at home for one hour once each week and maintains a strict neutrality. The field of observation is the relationship that is established between the baby and its mother, within the context of the transference instituted between the mother and the observer, and between the mother and her baby. The objective is training the observer in analytic work rather than the fabrication of an instrument for research. This method, used for the training of psychoanalysts and childhood specialists, later proved to be a remarkable tool for early treatment.

In 1948, at the request of John Bowlby, Bick developed a method of infant observation in a family context. As Bick explained in “Notes on Infant Observation in Psycho-Analytic Training” (1964), the aim

was to provide an opportunity for practical experience as a part of first-year training for therapists at the Tavistock Clinic.

In 1963, Bick presented her method of observation to the British Psychoanalytical Society (BPS). A consensus was established among the various English schools that this method would be integrated into the first-year curriculum; the attentive observation of an infant's development enables the future analyst to live out a number of fundamental emotional experiences, then to think them through within the framework of the work group. It was Sigmund Freud's grandson, W. Ernest Freud—the “child playing with the spool”—who promoted this method for therapists at the Anna Freud Center, as he related in “Infant Observation: Its Relevance to Psychoanalytic Training.” (1975). Bick's method of observation is a part of analytic training within the Spanish and Belgian psychoanalytic societies. Bick herself recommended training in this method for all categories of professionals involved in children's mental health.

In France, André Green strongly opposed the use of direct observation, noting in “Entretien avec Pierre Geissmann à propos de l'observation des bébés” (1992; Interview with Pierre Geissmann on infant observation) that it carries the risk of externalizing psychic life and confusing the infantile with the actual infant, which runs contrary to the work of representation and the spirit of psychoanalysis.

Bick's method was a conceptual innovation, described as “a stroke of genius” by Martha Harris. It is a precise technique used in a fixed framework, whose goal is the training of the analyst. The observer must be able to find a space within the family that is sufficiently neutral, yet not rigid, to enable him or her to experience the emotional impact of the baby's presence, without taking action. He or she must come unburdened by theoretical preconceptions, and be receptive without interfering. After the observation, the observer writes a report that conveys his or her experiences to a work group, which keeps an eye on methodological ethics and helps to make sense of the observed material. Observing a baby presupposes an ability to identify with the different points of view of family members; this flexibility makes it a sound preparation for analytic work. Through the analysis of his or her countertransference in relation to both the mother and what he or she feels from the baby, the observer can understand the impact of the mother's

fantasies on the baby's mental space and perceive the manner in which the baby responds to this. Thus, the specific type of affective and counter-transferential opening up inherent in observation makes it an aid to the development of the future analyst's capacities for free-floating attention.

The observer's presence is a source for change. It often has beneficial effects for most families: helping the mother emerge from postpartum depression, developing the parents' attention-giving abilities, modulating the effects of repetition of the mother's past on the baby. Bick's method opened the way for new therapeutic possibilities. Infant observation in day-care facilities, hospitals, and in the home has been developed to sensitize staff, as a preventive measure against early disorders, and with a view to therapeutic intervention in cases of autistic or psychotic pathologies.

In day-care facilities, the main indicators for setting up observation are:

- Mental dysfunction in the mother. The containing effects of observation serve as a protective shield and allow for a reshaping of the imagos;
- Children who have to be entrusted to a series of foster care situations owing to inadequacies on the part of the parents can benefit from the presence of an observer who follows them from one place to the next;
- When a child has a disability that is traumatic for the parents. The observer tries to get them to recognize the child's performances and the support he or she needs;
- Early autistic or psychotic disorders. The observer serves as a support for child-raising and the parents. He or she identifies the sources of suffering, defense mechanisms, and factors that hinder the child's development, and helps to improve the family's responses in the form of caregiving and listening skills.

In hospitals, in obstetrics wards and neonatal intensive care units, attention given to the baby, especially when he or she seems to be disorganized, enables both medical providers and parents to "think" the baby, to find meaning in interactions, and to avoid functional repetition.

Observation is a remarkable tool for prevention and treatment. It is an aid to the baby, who is helpless

in the face of its intense anxieties, to the mother in need of solicitude, and to other caregivers.

CHRISTINE ANZIEU-PREMMEREUR

*See also:* Archaic; Infantile psychosis; Infant observation; Infant observation (direct); Premature-prematurity; Tenderness.

### **Bibliography**

- Bick, Esther. Notes on infant observation in psycho-analytic training. *International Journal of Psycho-Analysis*, 45, 558–566.
- Freud, W. Ernest. Infant observation: its relevance to psychoanalytic training. *Psychoanalytic Study of the Child*, 30, 75–94.
- Green, André. Entretien avec Pierre Geissmann à propos de l'observation des bébés. *Journal de la psychanalyse de l'enfant*, 12, 133–153.
- Haag, Michel, and Geneviève Haag. L'observation des nourrissons selon Esther Bick (1901–1983) et ses applications. *L'Information psychiatrique*, 1 (1995): 7–17.
- Pérez-Sánchez, Manuel. (1981). *L'observation des bébés*. Paris: Clancier-Guénaud.

---

## **INFANTILE AMNESIA**

Infantile amnesia results from the repression of childhood polymorphous sexuality and the oedipal complex during the latency period. It constitutes a reference point and a model for subsequent (especially hysterical) amnesias and repressions. It "hides the earliest beginnings" of our lives "up to the sixth or eighth year" even though we have "good reason to believe that there is no period at which the capacity of receiving and reproducing impressions is greater than precisely during the years of childhood" (Freud, Sigmund 1905d, p. 174–175).

The notion of amnesia is defined by Freud in his *Three Essays on the Theory of Sexuality* (1905d), when he develops his conception of infantile sexuality. Having conceived since 1895 of the notion of hysterical amnesia, he now acknowledges an amnesia bearing upon the first six to eight years of life, contrasting with the capacity of the child's memory and its ability to register impressions. The infantile impressions falling under this amnesia constitute the reference point and model for later amnesias in the adult, helped into being by the

preexistence of a repressed that attracts to itself any elements of the subject's current life that resemble it.

Freud compares infantile amnesia to the hysterical amnesia of adults and suggests that in both cases the process would consist "in a simple withholding of these impressions from consciousness, viz., in their repression" (1905d, p. 175). That withheld from consciousness (repressed) includes infantile sexuality, defined as "polymorphous perversity," which thus allows Freud to say that "neurosis is the negative of perversion." This formulation could be attributed to a belief that the lifting of amnesia (hysterical and infantile) would permit the subject to follow in a reverse direction the path that leads from a childhood that did not endure censorship to neurosis. But Freud came to distinguish between a lifting of amnesia and a true lifting of repression in "Remembering, Repeating and Working-Through" (1914g). In "Constructions in Analysis" (1937d), this belief came up against the idea of sexuality as structurally linked to anxiety through the effects of the death drive.

The sexuality of the neurotic preserves important pregenital infantile traits. The hysteric refuses the perverse dimension of these traits all the more so since the child that they once were had already refused them during the latency period. Infantile amnesia creates for everybody a kind of "enigmatic prehistory." The infantile prehistory finds the infant, who is just beginning to speak, imbued with primal fantasies that become the object of a radical amnesia, primal repression. In the *Three Essays on the Theory of Sexuality*, this is not specifically a question of the Oedipus complex; however, it much be understood that infantile amnesia bears upon the entire "polymorphously perverse infantile sexuality/Oedipus complex," the oedipal conflict in turn reinforcing the censorship of infantile sexuality.

It is notable that Freud theorizes infantile amnesia moreover starting from the observation of children outside the analytic setting rather than from adults recalling their childhoods in analysis. Infantile amnesia covers over the mnemonic traces of childhood, about which Freud says in *The Interpretation of Dreams* (1900a) that they are "outside of time" and "indestructible," which would tend to define all unconscious psychic life as infantile in its essence, on the condition that what is psychically infantile be distinguished from the real infant.

FRANÇOIS RICHARD

See also: Memories; Memory.

### Bibliography

- Freud, Sigmund. (1900a). The interpretation of dreams. *SE*, 4–5: 1–751.
- . (1905d). Three essays on the theory of sexuality. *SE*, 7: 123–245.
- . (1914g). Remembering, repeating and working-through (further recommendations on the technique of psycho-analysis, II). *SE*, 12, 145–156.1

## INFANTILE NEUROSIS

A psychogenic mental disorder, infantile neurosis manifests expresses a psychic conflict that has been symbolically noted in the subject's early childhood. The term is used to designate either a disorder characterized by neurotic pathology, with variable prognostications, or a transference neurosis, constituting the prolegomenon of adult mental problems. Infantile neurosis is organized in terms of a dependency model. This results in counter-transference reactions on the part of the adult, which can be dangerous for the future development of the child, especially if the adult concerned remains oblivious to such a possibility.

"Little Hans" was treated by his father, who was in turn "supervised" by Freud. Freud himself only saw this five-year-old boy twice. Hans suffered from a phobia that prevented him from any activity, a fear that arose from having seen a horse fall on the ramp at the Vienna railroad station. When Freud saw Hans again as an adult, his parents had separated and he had drawn closer to his father. He did not recognize Freud, and he did not appear to be very healthy mentally. The son of a musician, by the end of his professional life he was director of the Geneva Opera, but his career left few traces. About all that is known about him is that he was interested in Wagner's Ring Cycle, that he staged the story of Brunhilde and Wotan, and that he was particularly taken with Siegfried's search for a mother in Brunhilde.

One might therefore agree with Jean Bergeret, who argued that this boy had a phobia linked to the his father's relations with his wife, who had been analyzed by Freud. Freud perhaps knew too much about this family's secrets. Despite the appearance of having been cured of his phobia through Freud's work of interpre-

tation, Hans suffered from a neurosis that certainly inhibited his creativity.

The cases of the “Wolf Man” and the “Rat Man” published by Freud have been the object of extensive commentary. The Wolf Man, Sergei Pankejeff, suffered from an infantile neurosis. Freud concentrated on describing the key fantasy of observing the coitus of the parents, especially in the context of the dream of wolves. In this nightmare, the patient saw immobile wolves, sitting on the branches of a tree and staring at him. Eventually the Wolf Man was declared to be psychotic. He died at the psychiatric hospital of Vienna after a number of psychotic episodes, which were treated by students of Freud. At the end of his life the Wolf Man said terrible things about Freud to a Viennese journalist. However, he had been supported by psychoanalysts, who purchased paintings in which he depicted his dream.

In fact, it was on the basis of this dream that Freud had decided to study the primal scene. He wanted to determine if the wolves that observed Pankejeff were placed in a situation opposite to the real one, when, as a child, he witnessed his parents making love. It seems probable that the coitus *a tergo* of animals had been attributed by the child to humans.

It is known that the Wolf Man had made the rounds of psychiatric services in Germany, ending up with Freud after seeing many other doctors. After he was financially ruined during the Russian Revolution, he married one of his nurses in Vienna. She was somewhat able to contain his madness. It is understandable that this man, who had paranoid tendencies, but was also persecuted in reality, would try to protect himself through various fantasies. But he needed to renounce them in order to find some peace and be able to return to a more normal life.

The Rat Man, who died during World War I, was traumatized in his childhood by his relations with the nurses who raised him and who had pathological sexual experiences with him. As an adult he suffered from an obsessional neurosis; many notes about Freud were found with him; and once in the course of a transference he attempted to transform Anna Freud into one of his nurses, insulting her constantly.

Neurotic symptoms in childhood do not necessarily lead to adult neuroses. In the adult, the existence of neurotic symptoms can mask an underlying psychotic structure. Furthermore, the study of the evolution of

certain cases of autism treated by psychoanalysis demonstrates frequent obsessional masking of psychoses, as is also the case in serious obsessional neuroses in children.

In Serge Lebovici’s report on the relation between infantile neurosis and transference neurosis presented to the Congrès des psychoanalystes de langue française des pays romans, he recalled Anna Freud’s theory that normal neurotic symptoms were a sign of good psychic health in a child during the oedipal phase: the repression of the drive is generally insufficient at that time, and thus transitory neurotic symptoms will arise. It has been demonstrated that the absence normal infantile neurosis is a sign of a predisposition to psychoses. However, subsequently Lebovici considered that his exposé should have been slightly rectified: normal infantile neurosis is also a sign of a solid narcissism, linked to a narcissistic cathexis with “His Majesty the Baby” on the part of his parents, who structure the ego of the child. The organization of intersubjectivity demonstrates the importance of family relations to the psychic life of the child. The kinship system accords a huge place to the imagined child, that is to say, to the imaginary and phantasmic child of the mother. This is contemporaneous with the child’s proto-representations. This ensemble communicates the presence of phantasmic interactions and also shows the importance of the role of the child in the psychic lives of the parents.

When this double process is satisfactory, the intergenerational transmission results in a solid and flexible ego. However, when there are “ghosts in the nursery” (Selma Fraiberg), this double process fails and the cultural constitution of filiation becomes impossible, illustrating the importance of studying the early interactive stage. But this work comes up against various obstacles that are not oedipal.

The triangulation process starts relatively early. It is preceded by a triadic arrangement, in the course of which the father and mother, in present-day society, play a specific role, allowing one to predict of the possible outcomes of triangulation. In the dull repetition of interactions, certain events are fundamental to the reconstitution of the interaction: they are “spoken backwards”—that is to say, they become truly significant events.

This perspective give understanding of the specific incidents in upbringing that demonstrate the modalities of the transmission of attachment, as



John Bowlby anticipated them. Mary Ainsworth has described this kind of attachment as the “strange situation,” transmitted according to genetic rules. The mechanisms of transmission in the adult follow the principle of a genetic transmission (Mary Main). Peter Fonagy has built on this idea, considering that children forced to deal with insecure transmission would benefit from a psychotherapeutic approach, which can modify the givens of this genetic transmission, as can be observed in thirty percent of cases. Studies on narration seem to confirm that episodic memory inscribes these givens, emphasizing the importance of the “proto-narrative envelopes” described by Daniel Stern.

SERGE LEBOVICI

*See also:* “Analysis of a Phobia in a Five-Year-Old Boy (Little Hans)”; “From the History of an Infantile Neurosis (Wolf Man)”; Infantile, the; Neurosis; Phobias in children; Prepsychosis; *Psychoanalytical Treatment of Children*; Transference neurosis.

### **Bibliography**

Freud, Sigmund. (1909b). Analysis of a phobia in a five-year-old boy. *SE*, 10: 1–149.

———. (1914c). On narcissism: An introduction. *SE*, 14: 67–102.

———. (1918b [1914]). From the history of an infantile neurosis. *SE*, 17: 1–122.

Lebovici, Serge. (1980). L'expérience du psychanalyste chez l'enfant et chez l'adulte devant le modèle de la névrose infantile et de la névrose de transfert. *Revue Française de Psychanalyse*, 64, 5–6, 733–857.

### **Further Reading**

Kris, Ernst, et al. (1954). Problems of infantile neurosis. *Psychoanalytic Study of the Child*, 9, 16–71.

Loewald, Hans W. (1974). Current status of the concept of infantile neurosis: Discussion. *Psychoanalytic Study of the Child*, 29, 183–190.

---

## **INFANTILE OMNIPOTENCE**

The sense of omnipotence that arises in the fundamental misapprehension of reality which is central to the period of primary narcissism, during which the infant hallucinates its original love-object, persists into childhood and is found among prehistoric and preliterate

peoples who overestimate the power of wishful thinking and the real-world effect of psychic acts. Infantile omnipotence is also a feature of obsessional pathology, in which it appears as superstitious or magical thinking; in psychosis, as delusions of grandeur; and, finally and to a lesser extent, in creative people who are able to momentarily escape reality and manipulate a world of fantasy. Sigmund Freud treated the concept of omnipotent thinking at length through investigations of primitive peoples and their beliefs in telepathic and animistic thought, and also through pathologies such as obsessional neurosis and psychotic megalomania.

Although Freud did not discuss it in these terms, narcissistic regression in sleep may be viewed as putting the dreamer in a situation typical of infantile omnipotence, able to realize frustrated desires of the previous day and, on a deeper level, to fulfill repressed wishes. Dreams revive the earliest situation of the nursing infant who seeks to re-experience satisfaction through primary process thinking—that is, to use hallucination to short-circuit reality. Perceptual identity is achieved by means that are rapid, regressive, and interior to the psychic apparatus. “It was only,” wrote Freud, “the non-occurrence of the expected satisfaction, the disappointment experienced, that led to the abandonment of this attempt at satisfaction by means of hallucination” (1911b, p. 219). Omnipotence in this sense is essentially indistinguishable from the capacity of the psychic apparatus to ignore reality and has universal purchase as an archaic function of the psyche.

For the child, learning the limitations that the reality principle imposes on the pleasure principle is in effect a limitation on its sense of omnipotence. However, as Melanie Klein (1921 [1919]) noted, the child's sense of omnipotence is also tied to that which it endows its parents and with which it identifies. Reality opposes it in either case. The “decline of the omnipotence-feeling that is brought about by the impulse to diminish parental perfection (which certainly assists in establishing the limits of his own as well as of their power) in turn influences the impairment of authority, so that an interaction, a reciprocal support would exist between the impairment of authority and the weakening of the omnipotence-feeling” (p. 17). In her view, the child's experience of omnipotence as increasing or diminishing will determine whether he or she will become bold and optimistic or fearful and pessimistic. However, she added: “For the result of development

not to be boundless utopianism and phantasy but optimism, a timely correction must be administered by thought" (p. 24). A compromise thus emerges between the pleasure principle that regulates wishes and fantasies and the area in which the reality principle prevails in the sphere of thoughts and established facts.

Donald W. Winnicott showed how the young child's mental activity can transform a "good-enough" environment into perfect surroundings. This transformation is necessary for object constancy not to be disturbed. By contrast, a defective environment is harmful because faulty adaptation overwhelms the psyche-soma of the young child and prematurely forces it out of its narcissistic universe. In terms of the illusion of creating the object and what he calls "transitional objects," Winnicott (1952) wrote: "We allow the infant this madness, and only gradually ask for a clear distinguishing between the subjective and that which is capable of objective or scientific proof. We adults use the arts and religion for the off-moments which we all need in the course of reality-testing and reality-acceptance" (p. 224).

Omnipotence does not disappear as childhood ends, but it delimits itself to specific areas and coexists with the recognition that reality imposes limitations upon it. Literary fiction and especially Romanesque adventure permits safe enjoyment of omnipotence through all manner of imagined danger. "It seems to me, however," wrote Freud (1908a), "that through this revealing characteristic of invulnerability we can immediately recognize His Majesty the Ego, the hero alike of every day-dream and of every story" (1908a, p. 150). Moreover, parents transmit omnipotence to the child inasmuch as "they are inclined to suspend in the child's favour the operation of all the cultural acquisitions which their own narcissism has been forced to respect, and to renew on his behalf the claims to privileges which were long ago given up by themselves... Illness, death, renunciation of enjoyment, restrictions on his own will, shall not touch him; the laws of nature and of society shall be abrogated in his favour; he shall once more really be the centre and core of creation—'His Majesty the Baby', as we once fancied ourselves" (1914c, p. 19).

SOPHIE DE MIJOLLA-MELLOR

See also: Alpha function; Amplification (analytical psychology); Anxiety; Arrogance; Borderline conditions;

"Claims of Psychoanalysis to Scientific Interest"; Dead mother complex; Dependence; Ego ideal; Ego ideal/ideal ego; Encopresis; Inferiority, feeling of; Good enough mother; Holding; Illusion; Infant observation (direct); Mania; Megalomania; Narcissism; Narcissistic defenses; Narcissistic elation; Omnipotence of thought; Paranoia; Pregnancy, fantasy of; *Psycho-Analysis of Children, The*; Quasi-independence, Transitional stage; Rite and ritual; Self (true/false); Self esteem; Silence; Squiggle; Suicidal behavior; Technique with children, psychoanalytic; Termination of treatment; Transference/counter-transference (analytical psychology); Transgression; Transitional phenomena; Transitional object; Transitional object, space.

### Bibliography

- Freud, Sigmund. (1908e). Creative writers and day-dreaming. *SE*, 9: 141–153.
- . (1911b). Formulations on the two principles of mental functioning. *SE*, 7: 213–226.
- . (1914c). On narcissism: An introduction. *SE*, 14: 81–105.
- Klein, Melanie. (1921 [1919]). The development of a child. In: *Love, guilt and reparation and other works, 1921–1945*, pp. 1–53. Delacorte Press, 1975.
- Winnicott, Donald W. (1952). Psychosis and child care. In: *Collected papers* (pp. 219–228). New York: Basic Books, 1958.

---

## INFANTILE PSYCHOSIS

Infantile psychosis has recently been replacing the notion of infantile schizophrenia. Infantile psychosis can be defined as precociously pathological organization that develops out of the integration of the earliest relations. Later forms of exteriorization can also be manifested in childhood. The age at the first outbreak, the greater or lesser stability of the supports of equilibrium that are constituted, and the nature of the defense mechanisms have significant repercussions on the risk and incidence of later negative developments.

The principal psychic mechanisms at work lie somewhere between the neurosis-psychosis opposition, posed by Freud, and the Kleinian theory of fantasy and the precocious Oedipus: the predominance of projection and projective identification, the fusion between real and imaginary, with infiltration of primal shattering fears, direct instinctual expression and the search for satisfaction by the shortest way, principally in the register of oral drives.

Clinical polymorphism, the absence of pathognomonic signs, and the failure of any common etiology of pathogenesis all characterize the category of the infantile psychoses in child psychiatry. Psychosis is diagnosed on the basis of the seriousness of perturbations, their atypical quality and their duration, in the context of various presenting symptoms—such as behavior problems, compromising of intellectual efficiency and functioning, retardation and/or language anomalies, expressions of great anxiety, sleep, eating, and sphincter conduit disorders; and in rare cases delirium and hallucinations. In terms of occurrence, a clear distinction has been established between schizophrenia that is declared in adolescence, without as much variety in the forms it takes, and the child schizophrenics who present more individualized particularities.

In the *Diagnostic and Statistical Manual of Mental Disorders (DSM)* of the American Psychiatric Association, psychoses are not listed as a disorder nosology, but rather placed under the rubric of “general developmental disorders” among which figures infantile autism. The overall “a-theoretical” cast of the ensemble and its descriptive corollaries suggest an organogenic and negative conception of psychosis, implying interventions that consist principally in reeducation.

Until the beginning of the twentieth century, this dominant understanding of infantile psychoses was still borrowed in large measure from that of nineteenth-century psychiatry; advocating medical pedagogical treatment (Bourneville, Seguin, Vallee), as well as psychometric approaches (Binet, Simon). Backwardness, states of idiocy and insanity, and their anatomical-clinical correlations in etiological matters were some characteristics of the dominant conception.

A threefold transformation of thought then contributed to the emergence of infantile psychoses:

- the application to ever younger children of models coming from advances in adult psychiatry and psychoanalysis;
- the rejection of these adulto-morphic models, as clinicians took account of the specificities of children;
- the gradual passing of the hypothesis of homogeneity, and the recognition of the heterogeneity of clinical tableaux and their underlying conditions.

Wilhelm Weygandt, Emil Kraepelin himself, and especially Sancte de Sanctis in 1908 with “*dementia praecox*,” described the infantile forms of early insanity. Yet all of this was merely followed the Kraepelinian model of the child. With the introduction by Eugen Bleuler of the category of schizophrenics (1911), the emphasis shifted from dementia to the dissociation of psychic functions (“*Spaltung*”). Among disorders called secondary—“responses of the sick soul”—was the hermetic isolation of “autism,” a term coined by Bleuler by subtracting “eros” from the Freudian notion of autoeroticism.

This new dynamic approach progressively influenced studies of children. From the thirties, in the United States (Charles Bradley, Howard Potter) and Europe (Georges Heuyer, Jacob Lutz, Léon Michaux), the notion of infantile schizophrenia, an autonomous endogenic illness resulting in a dramatic alteration in the developmental curve, became a familiar one. For Lutz, it was strictly opposed to organic and encephalopathic madness, or to gradually developing retardation. An overall conception of the malady was enlarged to include different clinical types and an approach to intra-familial relations. The work of Melanie Klein and her treatment of psychotic, even autistic children (cases of Dick, 1930; Erna, 1932) was especially influential, and took place well before the descriptions of precocious infantile autism by Leo Kanner (1943) and of symbiotic psychosis by Margaret Mahler (1952).

The emergence of the concept of infantile psychosis first in the United States, then in Europe, from the end of the 1940s is linked to several factors:

- the dissemination of psychoanalytic works relative to children and concerning early development: Melanie Klein, already mentioned, Anna Freud, René Spitz, Donald Winnicott;
- a progressive disengagement from any etiological presupposition;
- a challenge to the notion of dementia as an endogenous condition with ineluctable processes which had been itself a factor in negative prognoses.

Post-Kleinian authors in Great Britain attempted to make further progress in investigating the origins of thought and its disorders: Herbert Rosenfeld located the role of projective identification in the psychotic process; Wilfred Bion stressed the impact of

destructive drives against activities of liaison, perception, and attention, while describing a normal projective identification; Hanna Segal developed the notion of “symbolic equation” in schizophrenia, where the symbol is confused with the thing it symbolizes.

In France, after the early work of theorization of Serge Lebovici, René Diatkine, Conrad Stein, and Denise Kalmanson came up with a comprehensive psychological profile of infantile psychoses. The contributions of Roger Misès and Jean-Louis Lang should also be emphasized as having illuminated the rapport between psychoses and flaws in organic constitution. While the neurosis-psychosis opposition still maintains considerable heuristic value, the complexity and flexibility of the child’s systems have resulted in proposing the concepts of pre-psychosis, developmental disharmony, and para-psychosis.

The British school, through Donald Meltzer, proceeded to a synthesis of the Kleinian concepts in the very unfolding of the psychoanalytic process in the child (1948) and the observation of stages of psychic growth and of “dimensionality.” Esther Bick’s insight into a primal mode of narcissistic identification, “adhesive identification” (1968), extended the hypothesis formulated by Winnicott of premature traumatic separation and psychotic depression. Subsequently, Frances Tustin developed an original conceptualization of autistic defense mechanisms, distinguishing “shell states” (autisms) from “confusable states” (schizophrenias), where there has been access to tridimensionality. Finally, the study of the competencies of the infant, coupled with direct observation as well as the notions of interactional epigenesis and phantasmic interactions (Lebovici, 1983), posed the problem of the consistency of psychoanalysis with new models of premature dysfunctions (Didier Houzel, Bertrand Cramer). The idea that the baby creates the mother as much as she creates the baby has contributed to reflection on the access to maternity (Racamier, 1979) and on the role maternal depression plays in the psychotic process.

Leo Kanner described early infantile autism (1943), and he deduced it from the Bleulerian concept of the autism of schizophrenia. It was then applied to the “extreme autistic solitude” manifested from the start of life beginning in certain children. However, the question of whether this is a special category, in spite of Kanner’s integration of it in the general framework of infantile psychoses, remains unresolved. The especially

rigid homeostasis of their constitution locates these children in the register of the unchangeable, capable of no effect of projection, action or possession. A line can be drawn here between autism and infantile psychoses. Because the autistic system is relatively unstable, future development, once a major breakdown has been avoided, will include passage by “symbiotic” madness. Some authors, however, see in this a confirmation of the developmental continuity of various forms of child psychosis.

Described by Margaret Mahler in the child of two to four years of age, “symbiotic psychosis” is based on a primal indistinction between the psyche of the baby and that of the mother, and on a regression to this state of “symbiosis.” Psychosis involves the tentative restitution of the mania of omnipotent fusion with the mother’s image. Marked by ambivalence, its symptomatology includes a loss of functional skills and major manifestations of disturbance at the prospect of a separation from corporeal contact. Its onset is connected with maturation of the functions of the ego and the unconscious mobility of parental cathexes. A manifestly pathological “symbiotic” upsetting of equilibrium, a result of separation or sudden loss, can result in a secondary autistic condition.

Other early developmental disharmonies, psychotic in structure and composite clinical articulation, have been described. One consideration is that psychoses that are externalized later, from the age of four-to-five to puberty, can be seen as evolving adjustments to these early forms, and in continuity with them. On the other hand, without underestimating the significance of unrecognized fault lines, they surface in children who seem safe from them. Clinical configurations correspond to variable classifications of the signs of a need for help, polymorphic in nature, as has been mentioned above. Pseudo-neurotic (phobias, obsessions) and pseudo-maladjustment forms should be remarked, as well as complex motor or instrumental disorders, and some school failures, where psychosis is a factor.

The ensemble of these theories, not excluding neurobiological, environmental, and historical factors, tends to be situated outside of linear reductive causality. For René Diatkine, the understanding of psychopathology necessitates a reflection on the etiology of “normalcy.” From the time of *The Interpretation of Dreams* (1900a), the Freudian hypothesis of the hallucinatory return of the experience of satisfaction linked

normal development and psychotic functioning. Melanie Klein, in her description of the precocious Oedipus and schizoid-paranoid and depressive positions, situated “early psychotic stages” as potentialities in any human being. Infantile psychoses were the result of fixation at this early pre-psychotic phase, in which splitting, introjection, and projection dominate. They signify the failure of the depressive phase central to the second six months of life, when the child is faced with persecutory anxieties of annihilation. Projective identification, with its dimension of aggressive intrusion into the body of the mother to control her from the inside, was the key to narcissistic object relations of the schizoid-paranoid position. However, Melanie Klein has been criticized for using metaphors borrowed from psychopathology to describe the general organization of the psyche—as well as for the absence of a clear conceptual opposition between neurosis and psychosis.

Serge Lebovici and René Diatkine are of the opinion that the ensemble of psychic functioning and the economic equilibrium between different systems are what permits the differentiation of every form of psychic organization with regard to the “treatment” of projective identification. Consequently, according to Diatkine, “the optimal form of development of the pre-Oedipean organization” could be represented “as an interaction between two psychotic positions (schizoid-paranoid and depressive positions)” (1955) which is similar to some of Bion’s formulations. Psychosis would correspond to the relative primacy of the primal processes in the lowering of tensions and the reestablishment of economic equilibrium, a condition of psychic continuity. The tendency toward repetition of this primacy is what is pathognomonic. Cathexis and meaning would be established, consequently, accorded to a “primal” logic, without suppression of secondary processes. René Diatkine emphasized the crisis, decisive for psychic development, leading to the installation of the object in the second six months of life. The presence/absence opposition assumes qualitative significance, and the maternal object, lost by definition as soon as constituted, is cathected ambivalently. The working through of the ambivalence is crucial, the object of love and hate being doubly inscribed, internally and externally. Symbiotic psychosis corresponds to the impossibility of working-through, a consequence of serious perturbations in the earliest exchanges: painful representation becomes

non-representation. The environment can contribute to the stabilization of this pathological equilibrium or it can favor the constructive recapture of mental representations. Projective identification, which becomes very significant when introjection organizes desire permanently in the depressive position, allows the loved object to be spared by addressing itself to a third party. This primal triangulation is the jumping off point of the oedipean constitution, as in Kleinian formulations. For Wilfred R. Bion, projected hatred and envy become so intense, in the pathological projective identification, that the identificatory object, unable to contain and work through them, is experienced as a “superego,” crushing and destructive of the capacities of psychic development. The inversion of the alpha function necessary for the assimilation of emotional experiences results in catastrophic hallucinations and anxieties.

Donald W. Winnicott regarded failures of the early processes of illusion-disillusion, shared between the mother and the child, as the source of the psychosis centered on phases of the formation of “the continuous feeling of existence.” The lack of access to a “primal maternal preoccupation” (1965) would deprive the subject of an essential early period of illusion. For Wilfred Bion, this particular maternal phase can be considered from the point of view of a mutual projective relation of identification between the mother and the baby, reintroducing the role of the object and the environment into Kleinian theories. The containing and working-through capacities of the mother are what soothe the persecutory anxiety of the child (“capacity for maternal reverie”).

Lacanian theorization relative to infantile psychoses were developed on the basis of the concepts of the foreclosure (the “*Verwerfung*” of Freud) of the Name-of-the-Father and of the mirror stage as “formative of the function of the I.” The foreclosed signifiers, outside of symbolization, return to the heart of the Real in hallucination. The mirror phase, between six and eighteen months, marks the first version of an ego in the experience of a primal identification, anticipating a corporal unity. For Maud Mannoni, psychoses are inscribed in the maternal unconscious, with the psychotic child being unrecognized as a desiring subject, excluded from access to oedipean triangulation, and frozen as partial object subjected to maternal omnipotence. Finally, Piera Aulagnier’s notion of the “imaginary body of the child” should be mentioned. This

introduces an imaginary working through by the mother, prior to birth and anticipating the libidinal cathexis of the baby. The pictographic representation of the complementary object zone, attached to the primal process, bears witness to the disjunctive ruptures of corporal space in psychosis.

In summary, it can be affirmed that, in clinical practice, psychotic polarity is represented by projective expansion, immediate hallucinatory satisfaction and disorganization, whereas neurotic polarity is represented by the efficacy of symbolic transmission, the multiplication of liaisons, and the capacity to differentiate and work through.

A desirable early psychoanalytic treatment, extended in time, in the context of flexible institutional guidelines, should go along with a recognition of the different levels, perceptible but unpredictable, of psychic functioning of patients, as well as of related family circumstances.

BERNARD TOUATI

*See also:* Adhesive identification; Anaclysis/anaclytic; Autism; Autistic capsule/nucleus; Autistic defenses; Black hole; Breakdown; Child analysis; Deprivation; Developmental disorders; Dismantling; *Empty Fortress, The*; Individual; Infantile schizophrenia; Lack of differentiation; Mirror stage; Primitive agony; Psychic envelope; Psychotic potential; Self-mutilation in children; Sucking/thumbsucking; Symbiosis/ symbiotic relation; Tube-ego.

### Bibliography

- Bick, Esther. (1968). The experience of the skin in early object relations. *International Journal of Psycho-Analysis*, 49, 558–566.
- Bion, Wilfred R. (1963). *Elements of psychoanalysis*. London: Heinemann.
- Bleuler, Eugen. (1952). *The group of schizophrenias*. (Joseph Zinkin, Trans.). New York: International Universities Press. (Original work published 1911)
- Diatkine, René. (1994). *L'enfant dans l'adulte ou l'éternelle capacité de reverie*. Neuchâtel-Paris: Delachaux & Niestlé.
- Diatkine, René, and Simon, Janine. (1972). *La psychanalyse précoce*. Paris: Presses Universitaires de France.
- Kanner, Leo. (1943). Autistic disturbances of affective contact. *Nervous Child*, 2, 217–250.
- Klein, Melanie. (1948). *Contributions to psychoanalysis. 1921–1945*. London: Hogarth Press.

Lebovici, Serge. (1983). *Le nourrisson, la mère et le psychanalyste*. Paris: Le Centurion.

Mahler, Margaret. (1952). On child psychosis and schizophrenia. *Psychoanalytic Study of the Child*, 7, 286–305.

Misès, Roger, and Moniot, Marc. (1970). Les psychoses de l'enfant. In *Encyclopédie médico-chirurgicale*, vol. *Psychiatrie*. Paris: E.M.C.

Racamier, Paul-Claude. (1979). *La maternité psychotique. (Commentaires et complément 1978 et 1979)*. Paris: Payot.

### Further Reading

Volkan, Vamik. (1995). *The infantile psychotic self and its fates. Understanding and treating schizophrenics and other difficult patient*. Northvale, NJ: Aronson Inc.

## INFANTILE SCHIZOPHRENIA

The French classification of childhood and adolescent mental disorders describes two psychoses under two rubrics: childhood-onset psychoses of the schizophrenic type and adolescence-onset psychoses of the schizophrenic type.

Nineteenth-century child psychiatry, it can be assumed, followed the models proposed by adult psychiatry. Valentin Magnan applied the adult psychiatric theory of degeneration to children. In the same vein, Ernest Dupré applied the theory of constitutions to children. Later, various authors described clinical cases of children that showed obvious adult forms of schizophrenia. Thus, in 1905 Sancte de Sanctis described *dementia præcocissima* on analogy with *dementia præcox*. In 1888 Jacques-Joseph Moreau de Tours wrote the first treatise on child psychiatry, *La folie chez l'enfant* (Madness in children). A year earlier, Hermann Emminghaus demonstrated that the description of mental illness in children should be separated from descriptions of adult mental illness.

In 1908 Theodore Heller described *dementia infantilis*, a clinical group of several illnesses generally of neurological origin with various components. At the First International Congress on Child Psychiatry, held in Paris in 1937, Lutz was the first to use the notion of infantile schizophrenia, of which he made a critical study. According to him, there are very few such cases. His presentation was supported by Georges Heuyer. Already English-speaking authors had extended the concept of infantile schizophrenia to cover everything in current practice conventionally referred to as “childhood

psychoses.” In 1943 Leo Kanner proposed isolating a particular morbid illness under the term “infantile autism.” This particular psychosis does not evolve toward schizophrenia. As a matter of practice, institutions that treat children do not admit the notion of schizophrenia, while the concept of autism is very widespread.

French psychiatry has described prepsychotic and parapsychotic states that evolve toward a state of disintegration accompanied by mental retardation and that can appear analogous to certain schizophrenic states in adults. In English-speaking countries, especially in institutions following the American classification in the *Diagnostic and Statistical Manual of Mental Disorders (DSM-IV)*, the notion of psychosis has disappeared and been replaced by the concepts of autism and of pervasive developmental disorders. Some of the latter disorders may develop into schizophrenia. In German psychiatry, which long maintained its influence over the Soviet and Eastern Bloc countries, childhood autism has long been described as an initial form of schizophrenia, with development into schizophrenia more or less inevitable.

Schizophrenia that begins during adolescence will not be treated here, for it is generally at this age that symptoms of schizophrenia are first manifested. Many authors believe that schizophrenic adolescents, who are often extremely intelligent, already had bizarre behavioral problems in childhood. Most authors, however, believe that schizophrenia appears in the young adult out of the clear blue sky. In conformity with this view, the World Health Organization’s *International Classification of Diseases (ICD-10)*, “Classification of Mental and Behavioral Disorders” lists autism and childhood disintegrative disorder, but not infantile schizophrenia. Lastly, Roger Misès has described childhood borderline pathologies, within which he included states that may develop into schizophrenia. He sees this as a failure of the development of narcissism. Although it is possible to invoke some cases of infantile autism that have unquestionably evolved in the direction of schizophrenic states, the onset of schizophrenia during the latency period is altogether exceptional.

Psychiatric morbidity in children whose parents suffer from mental disorders is significant. However, these disorders are usually neuroses. When one parent is schizophrenic, the child has a 20 percent chance of being schizophrenic, whereas the rate is only 3 percent when neither parent is schizophrenic. Children adopted by parents listed on the schizophrenic register

are more likely to be psychotic than those who are apparently the children of schizophrenics. These studies, carried out in Chicago and in the Scandinavian countries, seem to be more probing than research involving identical twins.

Some serious neurotic states, especially obsessive-compulsive disorders, may be a neuroticization of certain childhood and adult psychoses. This is what Joyce McDougall and Serge Lebovici described in *Un cas de psychose infantile (A case of infantile psychosis; 1960)*. They describe the case of a child whose analysis was stopped by his parents. The parents wanted to place the boy in the care of Bruno Bettelheim. The mother of this boy said the boy was suicidal, and the boy, according to his father, became a “homosexual schizophrenic” who was among “the wealthiest Americans.” At the end of his analysis, the boy would make sure that the subway had indeed stopped in each station and would go down to check its exact position. The neuroticization of his “schizophrenia” thus led to an obsession with checking that impeded subway trains from leaving the station.

It is legitimate to wonder whether true obsessional neuroses that appear from the latency period on are not preschizophrenic. Generally, very bizarre obsessions are involved, as in the case of a boy who wanted to make certain that falling snow made no sound. These obsessional neuroses are not mild schizophrenias that have already led to a degree of defensive obsessive behavior. In adulthood, schizophrenic decompensations can emerge, as in one case of traumatic schizophrenia in a preadolescent girl who saw her sister, caught in the eddying currents of the Loire River, drown. She first blamed herself, in the manner of a delusional melancholic, then became schizophrenic.

Clearly, as these few cases show, infantile schizophrenia is rare.

SERGE LÉBOVICI

*See also:* Autism; Deprivation; Double bind; Infantile psychosis; Lack of differentiation.

### **Bibliography**

- McDougall, Joyce, and Lebovici, Serge. (1960). *Un cas de psychose infantile*. Paris: Presses Universitaires de France.
- Misès, Roger. (1990). *Les pathologies limites de l'enfance*. Paris: Presses Universitaires de France.

## INFANTILE SEXUAL CURIOSITY

Infantile sexual curiosity must be distinguished from the “investigative drive” in that the former directly cathects sexuality. Secondarily, it can stimulate the activity of the latter, which is also directed at non-sexual objects and gives rise to theories (infantile sexual theories). For Freud, in fact, the investigative drive is “awoken” (*geweckt*) by sexual curiosity, which responds to the “selfish” interest of self-protection from the birth of younger siblings.

Sexual curiosity initially involves an interest in seeing the genital organs and sexual relations (scopophilic drive). This visual pleasure can develop into voyeurism without necessarily leading to a sublimated cathexis of the enigma surrounding sexuality and of enigmas in general. Although sexual curiosity is linked to the investigative drive and constitutes the form in which it first emerges, the quest for the sight of an object of desire nevertheless continues to play a predominant role. It may be surprising that Freud should accord this preeminent position to sexual curiosity, to the extent of regarding it as the starting point of the child’s investigative activity, whereas in fact the child displays from the earliest months an all-consuming curiosity about everything that surrounds him.

In fact, this curiosity already differs from the scopophilic drive both through its choice of an absent object, the mother’s penis (cf. Little Hans, 1909b), as a preferred object and because it is not restricted to the pleasure of seeing but immediately develops into a need for self-comparison with the object being looked at (“The ego is always the standard by which one measures the external world,” 1909b, p. 107). Unlike the scopophilic drive, which can undergo a perverse development (voyeurism) or invent the absent object by remaining fixated on it (fetishism), sexual curiosity goes beyond this register by cathecting its enigmatic dimension. In this sense, it is already undergoing a sublimatory development, even if the investigation has not yet been formulated as an independent objective. The existence of an enigma presupposes the existence of a premonitory knowledge that is not necessarily possessed. In the “Wolf Man” case (1918b [1914]), concerning the primal scene, Freud hypothesizes that the understanding of the sexual process, as well as its meaning, is conceivable even at such an early age, if it is compared with the instinctive knowledge of animals (*instinktives Wissen*). This curiosity would then be the

disposition to cathect a scene of which the meaning is intuited, giving it an enigmatic quality. However, the value of the scene in question derives only from that which is not visible, that is to say its meaning, as distinct from what is directly perceived. Sexual curiosity differs from voyeuristic pleasure in the same way, as can be stated following Freud: “An advance in intellectuality consists in deciding against direct sense-perception in favour of what are known as the higher intellectual processes—that is, memories, reflections and inferences” (1939a, [1934–38], pp. 117–118).

Sexual curiosity (epistemophilia) was extensively discussed by Melanie Klein, who emphasized that it precedes the child’s understanding of language and, because of his immaturity, contributes a great deal of frustration and a sense of ignorance that reinforce the castration complex. Melanie Klein also emphasizes the connection of this curiosity with sadism and the anal-sadistic libidinal position, which makes the child want to appropriate the contents of the body and particularly the mother’s body, which is thought to possess the penis and the babies.

Sexual curiosity does not necessarily mean that the child is asking questions about sexuality. Rather, this seems in fact to be displaced, with the child posing innumerable, often stereotypical questions to which he does not appear to expect answers because they substitute for those questions that repression prevents him from asking and in regard to which alone he could be satisfied.

Infantile sexual curiosity, in its denied form (inhibition, disgust) or its obsessional form, plays an important role in infantile symptomatology. It has important consequences for learning at school (Klein, 1923). Freud takes this viewpoint a step further by considering the failure of infantile sexual curiosity as a paralyzing factor in later life: “The impression caused by this failure in the first attempt at intellectual independence appears to be of a lasting and deeply depressing kind” (1910c, p. 79).

SOPHIE DE MIJOLLA-MELLOR

*See also:* “Analysis of a Phobia in a Five-Year-Old Boy” (Little Hans); Myth of origins; “On the Sexual Theories of Children”; Phallic stage; Phobias in children; “Sexual Enlightenment of Children, The”; Thought.

### Bibliography

Freud, Sigmund. (1905d). Three essays on the theory of sexuality. *SE*, 7: 123–243.



———. (1909b). Analysis of a phobia in a five-year-old boy. *SE*, 10: 1–149.

———. (1910c). Leonardo da Vinci and a memory of his childhood. *SE*, 11: 57–137.

———. (1918b [1914]). From the history of an infantile neurosis. *SE*, 17: 1–122.

Moses and monotheism: three essays. *SE*, 23: 1–137.

Klein, Melanie. (1923). The development of a child. *International Journal of Psychoanalysis*, 4, 419–474.

Mellor-Picaut, Sophie. (1980). La vision et l'énigme. *Topique*, 25.

## INFANTILE, THE

In *Au vif de l'infantile* (At the heart of the infantile; 1996), Florence Guignard wrote: “The basic structure at the fringes of our animality, the repository and container for our drives, libidinal or hateful as well as epistemophilic, the infantile is the ‘malleable’ alloy of the instinctual and structural that makes one oneself and not some other person. Irreducible and unique, and by those very qualities universal, the infantile is thus what enables our psyche to come into being, in all the developments of its psychic bisexuality organized by the Oedipus complex.”

The concept of the infantile was born with psychoanalysis in the sense that Sigmund Freud's discovery of infantile sexuality caused the observation of psychic phenomena to move from the level of consciousness to the level of the unconscious. Both the child one sees in reality and the childhood one remembers elicit reflection about processes of secundarization, and neither constitutes the specificity of the infantile as it is revealed within the psychoanalytic setting itself. It was by thinking about the psychic causality of pathological phenomena that Freud discovered the infantile origins of the neuroses, and later the psychoses. In this way, he established a bridge between the actual structures of the mind—that of the adult analysand, but also that of the child in analysis—and the ways these structures have been informed, through deferred action during an infantile period that is reconstructed in analysis. Dreams are what give the most direct access to the infantile layers of the psyche, since the latter are so deeply hidden by the processes of primary and secondary repression.

In “L'expérience du psychanalyste chez l'enfant et chez l'adulte devant de modèle de la névrose infantile et de la névrose de transfert” (The analyst's experience

with children and adults in terms of the models of infantile neurosis and transference neurosis; 1980) Serge Lebovici specified the organizing aspects of infantile neurosis as opposed to neurosis in children. The taking over of neurotic elaboration by infantile neurosis enables the adult analysand to develop a genuine transference neurosis. In this conception the capacity to develop a transference neurosis is based in the formation of bonding processes. The infantile is thus what expresses a stratum of mental life that is as inaccessible to consciousness as the unconscious material that resides in it, yet it serves as a nodal point that makes it possible to go back and forth between past and present.

In “L'enfant, l'infantile et la causalité psychique” (The child, the infantile, and psychic causality; 1994), Bernard Brusset uncoupled the infantile from the historical, thus differentiating between causal biography (that of the infantile) and reconstructed biography (that of the child). Thus the infantile can be assimilated into the unconscious (Agnès Oppenheimer), to the extent that the infantile is not observable, or that it is observable only in the form of reconstruction or deferred action. This view thus posits the infantile as a turning point in the reworking of primal fantasies.

Making the infantile that which is unconscious and unrepresentable opens the way for a rethinking of the work of psychoanalytic observation both of the adult and of the child by the adult: To be truly psychoanalytic, any observation must involve a dimension in which the infantile within the observer responds to the infantile of the person being observed. It is this transference/countertransference echo that means that one is no longer faced with the child, but rather the approach of the infantile. This involves putting into perspective both the child and the infantile within the adult, and recognizing, in the adult's “infantile” reaction, not the child he or she once was, since that child existed only for a time, but rather the infantile playing itself out within the child.

CLÉOPÂTRE ATHANASSIOUS-POPESCO

### Bibliography

Brusset, Bernard. (1994). L'enfant, l'infantile et la causalité psychique. *Revue Française de Psychanalyse*, 58, 3, 693.

Guignard, Florence. (1996). *Au vif de l'infantile*. Paris: Delachaux and Niestlé.

Lebovici, Serge. (1980). L'expérience du psychanalyste chez l'enfant et chez l'adulte devant le modèle de la névrose infantile et de la névrose de transfert. *Revue Française de Psychanalyse*, 44, 5–6, 733–857.

Oppenheimer, Agnès. (1994). Enfant, enfance, infantile. *Revue Française de Psychanalyse*, 58, 3, 707.

## INFERIORITY, FEELING OF

The term “feeling(s) of inferiority” refers to a group of representations and affects that reflect an individual's self-devaluation in relation to others. In *The Interpretation of Dreams* (1900), Sigmund Freud mentioned a dream marked by both feelings of inferiority and infantile omnipotence. The thematic content of this dream is explicitly anal, which is significant, since Freud later often returned to anal issues as forces that can have a positive or negative impact on self-esteem.

Freud addressed feelings of inferiority, notably, in his analyses of the cases of the Rat Man (1909d), Schreber (1911c), and the Wolf Man (1918b). He also took up this theme in his formulations on narcissism (1914c). But above all, he examined feelings of inferiority with especially keen insight within the framework of the oedipal complex. In his paper on a child's fantasy of being beaten (1919e), he wrote that this fantasy, as well as other, analogous perverse fixations, were “precipitates of the Oedipus complex, scars, so to say, . . . just as the notorious ‘sense of inferiority’ corresponds to a narcissistic scar of the same sort” (p. 193). Within the oedipal framework, the threat of castration that weighs upon the little boy distorts his self-esteem, and the absence of a penis leads the little girl to devalue herself. In both cases, feelings of inferiority are intimately linked to the guilt inherent in the oedipal drama. The loss of love of the object and the sense of rejection accentuate this feeling.

Freud revised these views when he formulated his structural theory of ego psychology. “There is always a feeling of triumph when something in the ego coincides with the ego ideal. And the sense of guilt (as well as the sense of inferiority) can also be understood as an expression of tension between the ego and the ego ideal,” Freud wrote in *Group Psychology and the Analysis of the Ego* (1921c, p. 131).

One can thus better understand why Freud so firmly opposed Alfred Adler when Adler wanted to make feelings of inferiority the keystone of his theoretical conceptions in *The Neurotic Constitution: Outlines*

*of a Comparative Individualistic Psychology and Psychotherapy* (1912/1926). In Freud's view, feelings of inferiority were a superficial manifestation—important in clinical work, to be sure, but understandable only within the framework of a more general metapsychology.

ROGER PERRON

*See also:* Adler, Alfred; Compulsion; Fanon, Frantz; Feeling of inferiority (individual psychology); Masculine protest (individual psychology); Social feeling (individual psychology).

### Bibliography

Adler, Alfred. (1926). *The neurotic constitution: Outlines of a comparative individualistic psychology and psychotherapy* (Bernard Glueck and John E. Lind, Trans.). New York: Dodd, Mead, and Co. (Original work published 1912)

Freud, Sigmund. (1900a). The interpretation of dreams. *SE*, 4: 1–338; *SE*, 5: 339–625.

———. (1909d). Notes upon a case of obsessional neurosis. *SE*, 10: 151–318.

———. (1911c). Psycho-analytic notes on an autobiographical account of a case of paranoia (dementia paranoides). *SE*, 12: 1–82.

———. (1914c). On narcissism: an introduction. *SE*, 14: 67–102.

———. (1918b). From the history of an infantile neurosis. *SE*, 17: 1–122.

———. (1919e). A child is being beaten: A contribution to the study of the origin of sexual perversions. *SE*, 17: 175–204.

———. (1921). Group psychology and the analysis of the ego. *SE*, 18: 65–143.

## INFERIORITY, FEELING OF (INDIVIDUAL PSYCHOLOGY)

As early as 1907 Alfred Adler considered the state of organic inferiority as a factor in neurosis before linking it to the newborn child's state of physiological immaturity. This state of inferiority is the source of the feeling of inferiority that persists throughout life: “Being a man means having a feeling of inferiority that constantly demands compensation” (1912/2002).

The life history of Alfred Adler, who suffered from rickets as a child, goes some way to explaining his insistence on the importance of the states of organic

inferiority at the root of the feeling of inferiority. He later observed the various modulations that the family and cultural environment, as well as the child's choices, introduced into this feeling, which he saw as a stimulant to psychic life. By way of compensation the child will elaborate a directing fiction representing an ideal being who has all the qualities that the child lacks, and will project itself into the future "in the shape of the father, mother, an older brother or sister, a schoolteacher, an animal or a God" (1912/2002). The gap between the self and the directing fiction is all the greater if the child has suffered frustrations or ill treatment and encounters no obstacles in its imaginary world.

Very early on this fiction will be adapted due to the influence of social and cultural factors and will express itself in the form of a counter-fiction (1912/2002). Psychic health is characterized by harmonious relations between the fiction and the counter-fiction, whereas the neurotic will remain under the control of the fiction, making an effort "to shine while acting modestly, to conquer while remaining humble and submissive, to humiliate others with his own apparent virtues, to disarm others with his passivity, to make others suffer through his own suffering, to pursue a virile goal with feminine means, to make himself small in order to seem big."

Compensation for an exacerbated feeling of inferiority can take the form of a superiority complex, the different manifestations of which Adler described in *The Neurotic Constitution*, whereas discouragement will take the form of an inferiority complex. In this case the subject will use neurotically rich symptoms to flee all situations that threaten its prestige, hence Adler's definition of neurosis: "An attempt to maintain the appearance of value at all costs, while desiring this goal without paying the price" (1930/1927).

Cultural influence manifests itself in the elaboration of the fiction through the choice of a model representing a virile ideal that leads to a mode of apperception that is in accordance with the opposition relation: masculine/dominant/superiority, feminine/defeated/inferiority. The social influence constitutes the correcting element that determines the feeling of inferiority. These two factors make up two lines of force that are present in the formation of the child's lifestyle, which can be compared to the program of perception and behavior with which the child complies unconsciously (1929/1964).

FRANÇOIS COMPAN

*See also:* Cinema and psychoanalysis; Inferiority, feeling of; Grandiose self; Object; Paranoia; Penis envy; "Some Psychical Consequences of the Anatomical Distinction between the Sexes."

### Bibliography

Adler, Alfred (1972). *The neurotic constitution: Outlines of a comparative individualistic psychology and psychotherapy* (Bernard Glueck and John E. Lind, Trans.). Freeport, NY: Books for Libraries Press. (Original work published 1930)

———. (1964). *Problems of neurosis: A book of case histories*. (P. Mairet, Ed.). New York: Harper & Row. (Original work published 1929)

———. (2002). *The neurotic character. Fundamentals of individual psychology and psychotherapy* (Cees Koen, Trans.). San Francisco: Alfred Adler Institutes. (Original work published 1912)

---

## INHIBITION

Sigmund Freud defined inhibition as "the expression of a restriction of an ego-function. A restriction of this kind can itself have very different causes." This definition appears in the opening pages of *Inhibitions, Symptoms and Anxiety* (1926d [1925]).

Analogizing from a medical definition of the concept ("restriction of an organ function") does not perfectly express the psychopathological specificity of the notion of inhibition. Thus when Freud states that the "ego-function of an organ is impaired if its erotogenicity—its sexual significance—is increased," (1926d [1925]) this mechanism, which is borrowed from the clinical psychoanalysis of hysteria, provides no psychopathological differentiation between the inhibition and the symptom.

In the same volume he also underlines the links between inhibition and the concept of anxiety: "Some inhibitions obviously represent a relinquishment of a function because its exercise would produce anxiety." In this way Freud tries to delineate the concept by comparing it with and distinguishing it from other notions that have been described by analytic theory, as indicated fairly clearly in the title of the work. Apart from the fact that they enable us to isolate a pure form of inhibition—"The libido may simply be turned away"—these efforts lead Freud to distinguish two types of inhibition "as a measure of precaution or

brought about as a result of an impoverishment of energy.” The study of these different mechanisms enables him to define the modalities of the opposition between inhibition and symptoms: unlike inhibition, “the symptom cannot any longer be described as a process that takes place within, or acts upon, the ego.”

This opposition makes it possible to define inhibition as a simple relinquishment at the level of the ego, where the symptom accomplishes a veritable compromise between the ego and the instinctual demands of the id. Freud offers an illustration of this in relation to the horse phobia in the case of Little Hans. In this case, “the inability to go out into the streets was an inhibition, a restriction which his ego had imposed on itself so as not to arouse the anxiety-symptom.” The phobic symptom cannot be described as such except when there has been “the replacement of his father by a horse. It is this displacement, then, which has a claim to be called a symptom.”

Emphasizing the fundamentally imaginary status of inhibition, Jacques Lacan reviewed his study in the seminar devoted to anxiety by opposing it to the notion of an act. The latter appears as a response of the subject forced to adopt a position in relation to its splitting. Unlike inhibition, the act “après-coup” inaugurates a new transformed subject: “Only action engenders certitude in the subject.” By means of this opposition, inhibition appears as an attempt on the part of the subject to defer an option, a choice to be made in relation to its desire. Like Freud’s dissatisfied tone in relation to the theories developed in *Inhibitions, Symptoms and Anxiety*, Lacan’s proposed extensions confirm the difficulties of apprehending the concept of inhibition but also its heuristic value.

NICOLAS DISSEZ

*See also:* Action-(re)presentation; Act, passage to the Allergy; *Civilization and Its Discontents*; Drive/instinct; Facilitation; Friendship; Idealization; *Inhibitions, Symptoms and Anxiety*; Infantile sexual curiosity; Jokes; Knowledge or research, instinct for; Oedipus complex, early; Ontogenesis; Orgasm; Pleasure in thinking; Prepsychosis; Sexual theories of children; Smell, sense of; Thought.

### Bibliography

Freud, Sigmund. (1926d [1925]). *Inhibitions, symptoms and anxiety*. *SE*, 20: 75–172.

Lacan, Jacques. (1966). *Écrits*. Paris: Éditions du Seuil.

## INHIBITIONS, SYMPTOMS, AND ANXIETY

*Inhibitions, Symptoms, and Anxiety* was published in German in 1926, a year after Freud’s famous article “Negation” (1925h) and “An Autobiographical Study” (1925d). Ernest Jones wrote that the work was written in July 1925, corrected in December, and then published in the third week of 1926 by Fisher Verlag of Frankfurt.

Concerning this work Sigmund Freud wrote, “It contains several new and important things, takes back and corrects many former conclusions, and in general is not good” (Jones, 1953–1957, vol. 3, p. 131). There were a number of “contradictions” in the translations, and it was not until 1936 that Alix Strachey finally produced a better translation, again according to the testimony of Ernest Jones, published by Hogarth Press in the “International Psycho-Analytical Library” series. In addition to Alix Strachey, “Freud had also given the translation rights to H. A. Bunker in New York without informing either translator of the other” (Jones, 1953–1957). At the same time a thirteenth edition of this text, lacking the passage about Alfred Adler and Carl Gustav Jung, was published in the *Encyclopaedia britannica* with a different title: “Psycho-Analysis: Freudian School” (1926f).

In any event, this was obviously an extremely important essay for the evolution of Freudian thought and should be seen, in large part, as a response to the ideas of Otto Rank in *The Trauma of Birth* (1929). As a curious side note, it is worth noting that when Freud was writing *Inhibitions, Symptoms, and Anxiety*, his daughter Anna was preparing “The Psychoanalytic Treatment of Children”; that is, while the father was investigating anxiety, separation anxiety in particular, his daughter was working on the distinction between child and adult psychoanalysis.

*Inhibitions, Symptoms, and Anxiety* is divided into ten chapters (without titles) and three addenda, entitled “Modification of Earlier Views,” “Supplementary Remarks on Anxiety,” and “Anxiety, Pain, and Mourning.” Some commentators saw in the fact that Freud discussed pain in the final addendum a reflection of the theoretical difficulties he had encountered in studying the phenomenon, which he had discussed earlier in *Mourning and Melancholia* (1916–1917g [1915]).

The first chapter discusses the connections between inhibitions and symptoms. The second presents the ego as the site of anxiety (“There are good grounds for

firmly maintaining the idea that the ego is actually the site of anxiety”) and sees the role of repression from a perspective different from Freud’s earlier one, which viewed anxiety as the automatic consequence of repression. Chapter 3 takes up the relations between the ego and superego. Chapter 4 returns to the phobia of “little Hans” to show that “the motive force of the repression was fear of castration” (p. 108). Chapter 5 focuses on obsessional neurosis and the mechanism of the formation of symptoms within this context. Chapter 6 further investigates the defense mechanisms of isolation and retroactive undoing within obsessional neurosis. Chapter 7 examines the problem of phobias. Chapter 8 provides a brief interlude in which Freud analyzes the experience of unpleasure and distinguishes object loss and the fear of object loss—a distinction that provides the framework for a discussion of automatic anxiety and signal anxiety. Chapter 9 then focuses on the relations between symptom formation and the development of anxiety. Finally, the last chapter distinguishes three factors that lead to neuroses: a biological factor (“the long period of time during which the young of the human species is in a condition of helplessness and dependence” [p. 154]), a phylogenetic factor (the two-stage development of sexual life, with emphasis given to puberty), and a psychological factor (the defects of the mental apparatus lead Freud to treat libidinal drives as dangers in the face of which the ego can only restrain its own mechanisms and tolerate the formation of symptoms “in exchange for having impaired the instinct” [p. 156]).

The key points in this theoretical text are the following: Freud challenges Otto Rank’s view on the trauma of birth, which Rank regarded as the prototype of all later anxieties. For Freud:

In man and the higher animals it would seem that the act of birth, as the individual’s first experience of anxiety, has given the affect of anxiety certain characteristic forms of expression. But, while acknowledging this connection, we must not lay undue stress on it nor overlook the fact that biological necessity demands that a situation of danger should have an affective symbol, so that a symbol of this kind would have to be created in any case. Moreover, I do not think that we are justified in assuming that whenever there is an outbreak of anxiety something like a reproduction of the situation of birth goes on in the mind (pp. 93–94).

In other words, Freud wanted to retain Otto Rank’s idea that birth provides a kind of mold or expressive

content for anxiety, but insisted that the mental content of the affect of anxiety is determined by later existential experiences and subsequent psychological reworkings of the affects. He also insisted that anxiety is experienced by the ego but not produced by it. Here he returned to his theory of anxiety by making repression not the cause but the result of anxiety. Thus, what is involved is not “automatic anxiety” but “signal anxiety,” which must now be accounted for. Signal anxiety reflects the significant adaptive and maturational progress of the child to the extent that anxiety is no longer a simple reaction to object loss but an anticipation of the threat of the loss of love from the object.

Finally, the text provided Freud with an opportunity for further investigation of mental pain, which reflects a loss of a part of the self rather than a loss of the object, in the strict sense. This led Freud to recognize the importance of the more or less narcissistic valence of the lost object, which serves to demarcate mourning and melancholic depression.

BERNARD GOLSE

*See also:* Abandonment; Anxiety; Anxiety development; Castration complex; Cathexis; Defense mechanisms; Ego; Ego psychology; Erotogenicity; Isolation; Obsessional neurosis; Pain; Phobias in children; Resistance; Signal anxiety; Substitutive formation; Undoing.

#### Source Citation

Freud, Sigmund. (1926d [1925]). *Hemmung, Symptom und Angst*, Leipzig-Vienna-Zurich, Internat. Psychoanal. Verlag; *G.W.*, 14:111-205; Inhibitions, symptoms, and anxiety. *SE*, 20: 77–172.

#### Bibliography

Freud, Sigmund. (1916–1917g [1915]). Mourning and melancholia. *SE*, 14: 237–258.

Jones, Ernest. (1953–1957). *Sigmund Freud: Life and work*. London: Hogarth Press.

Rank, Otto. (1929). *The trauma of birth*. London: Kegan Paul, Trench, Trubner and Co. (Original work published 1924.)

---

## INITIAL INTERVIEW(S)

The term *initial* or *preliminary interview(s)* refers to the meeting or meetings that take place between a psychoanalyst and the person who must decide whether

or not to enter into analysis. The purpose of the initial interview or consultation is to determine the person's need for treatment.

The initial interview became standard procedure at the same time that Sigmund Freud clearly instituted the framework for the psychoanalytic situation: patient lying down, analyst hidden from the patient's view. These conditions in fact produce a radical change in a relationship that, during the preliminary interview, was fairly similar to consultation with a physician or psychologist, or indeed an interview for the purpose of soliciting advice of any type.

The issue of course is whether analysis is indicated, and this implies referring to criteria assessing "analyzability" and the degree to which such an undertaking is possible. From the beginning, however, from the phone call setting up the first meeting, the subtle mechanisms of transference and counter-transference are set in motion, shedding an entirely different light on the criteria for choices.

It is because of these intersubjective parameters that Freud advised, in "On Beginning the Treatment (Further Recommendations on Technique of Psycho-Analysis)" (1913c):

I may add . . . that I have made it my habit, when I know little about a patient, only to take him on at first provisionally, for a period of one to two weeks. . . . No other kind of preliminary examination but this procedure is at our disposal; the most lengthy discussions and questionings in ordinary consultations would offer no substitute. This preliminary experiment, however, is itself the beginning of a psycho-analysis and must conform to its rules. . . . Lengthy preliminary discussions before the beginning of the analytic treatment, previous treatment by another method and also previous acquaintance between the doctor and the patient who is to be analyzed, have special disadvantageous consequences for which one must be prepared. They result in the patient's meeting the doctor with a transference attitude which is already established and which the doctor must first slowly uncover instead of having the opportunity to observe the growth and development of the transference from the outset (pp. 123–125).

In 1930, his responses to his analysand Smiley Blanton, as revealed in the latter's *Diary of My Analysis with Freud* (1971), showed no change in this point of view. According to Blanton's entry for March 7, Freud told him: "[T]he lying down is but a matter of

convenience. But there is one point that is essential: the analysand must not see the face of the analyst. If he did, he would be influenced by the face of the analyst" (p. 50). In his entry for August 9, 1935, Blanton recalled: "In a discussion about technique, I asked Freud if he advocated talking to a patient several hours before analysis—or, rather, to begin an analysis with several hours of discussion. He replied, "With a student in training it may be permissible. With a patient who is there for treatment, no" (p. 71).

In later years, trial analysis fell out of practice, and the status of the preliminary interviews has become somewhat vague; these vary, according to different schools, in their frequency and duration, as well as in terms of whether they may be free of charge. Some practitioners limit them to one or two meetings, the latter case being intended to assess the patient's capacity for insight and working over, following the initial meeting: Was there a dream, a parapraxis, a lifting of amnesia, or an instance of acting out? Other analysts advise having several interviews to avoid the possibility of having to interrupt an analysis that, too late, turned out to be unjustified. Several authors have emphasized the importance of preliminary interviews with borderline patients, for whom, more than with other patients, possible modifications to the analytic situation may be considered.

The analyst's listening attitude, the absence of questions of a medical nature, discreet emphasis on preconscious manifestations, recognition of mental suffering and its possible modes of expression other than acting out, and assessing possible lateral transferences (if a colleague has already interviewed the patient) are among the themes evoked most frequently by authors in their discussion of preliminary interviews. Similarly, these authors have underscored the need, once the preliminary interviews have ended and if a decision has been made to undertake analysis, to establish clearly and in detail with the patient the conditions in which the treatment will take place. Such conditions include the length and frequency of sessions, scheduled times for them, method of payment, policy in case of absence from sessions, and vacation periods.

Also to be considered is certain psychoanalysts' practice of switching to a classical analytic mode of treatment after a long series of sessions of psychoanalytically inspired therapy; in their view, this move is similar to what happens after traditional preliminary

interviews. In all cases, there remains first and foremost the problem, raised by Freud, of the psychoanalytic handling of the transference and countertransference, which in the classic view is only possible within the psychoanalytic setting.

ALAIN DE MIJOLLA

*See also:* Analyzability; Framework of the psychoanalytic cure; Psychoanalytic treatment; Face-to-face situation; Indications and contraindications for psychoanalysis for an adult; Technique with adults, psychoanalytic.

### **Bibliography**

- Blanton, Smiley. (1971). *Diary of my analysis with Freud*. New York: Hawthorn.
- Freud, Sigmund. (1913c). On beginning the treatment (Further recommendations on technique of psychoanalysis I). *SE*, 12: 121–144.
- Pulver, Sydney E. (1995). The technique of psychoanalysis proper. In *Psycho-Analysis, the major concepts*, edited by E. Moore Burness and B. D. Fine. New Haven and London: Yale University Press.
- Quinodoz, Danielle. (1992). The psychoanalytic setting as the instrument of the container function. *International Journal of Psycho-Analysis*, 73, 627.

### **Further Reading**

- Console, William, et. al. (1977). *The first encounter: The beginnings in psychotherapy*. New York: Jason Aronson.
- Gill, Merton, et. al. (1954). *The initial interview in psychiatric practice*. New York: International Universities Press.
- Jacobs, Theodore J., and Rothstein, Arnold. (Eds.), (1990). *On beginning an analysis*. Madison, CT: International Universities Press.

## **INNERVATION**

Freud uses the term *innervation* throughout his work, both with and without reference to hysterical conversion. We find it in its physiological and anatomical meaning as an efferent or afferent mode of action of the nervous system and/or distribution of nerves in a region of the body: “sensation of innervation,” “voluntary or involuntary innervation of the muscles,” “innervation of the brain,” “body innervation.” But we also find, more rarely: “innervation (tears),” “sensation of the innervation of the word,” “sensation of speech innervation,” “innervation of images of *movement*.”

For Freud the theory of conversion took shape within the very broad framework of these meanings: “the inhibited antithetic idea can put itself into effect by innervation of the body” (1892–93a, p. 122). As soon as the term *conversion* appeared, it was often linked to *innervation*. Two examples: “The affect that is torn [from the repressed idea] would be used for a somatic innervation. (That is, the excitation is ‘converted’.)” (1895d, p. 285), and “in the case of conversion hysteria the circuitous route led to the somatic innervation; the repressed impulse broke its way through at some point or other and produced *symptoms*” (1925d, p. 33).

The notion is not much used by psychoanalysts today. Although linked to Freud’s earliest paraneurological speculations, it has nevertheless been retained in relation to hysteria, for example, as a reaffirmation in Freud’s opinion of a correspondence or an indissoluble continuity between the psychical and the physical.

BERTRAND VICHYN

*See also:* Conversion; Hysterical paralysis; Mnemic symbol; Psychosomatic limit/boundary; Sum of excitation; Symptom

### **Bibliography**

- Freud, Sigmund. (1892–93a). A case of successful treatment by hypnotism. *SE*, 1: 115–128.
- . (1895d). Studies on hysteria. *SE*, 2: 48–106.
- . (1940e [1938]). Splitting of the ego in the process of defence. *SE*, 23: 271–278.

## **INSIGHT**

In psychoanalysis, insight is a process whereby one grasps a previously misunderstood aspect of one’s own mental dynamics. It refers to a specific moment, observable during the treatment, when the patient becomes aware of an inner conflict, an instinctual impulse, a defense, or the like, that was previously repressed or disavowed and that, when it emerges into consciousness, elicits surprise and a sense of discovery.

Two forms of the experience have been described. The first involves a feeling of sudden discovery or illumination—a kind of “Eureka!” moment. The second is a slower, more gradual process where the subject and usually the analyst as well experience a sensation of the

obvious: “Yes, that’s how it is. We knew this, of course, but now it’s perfectly clear.” In all cases, something other than simple intellectual comprehension is involved. Frequently, understanding at a lower level, laden with cultural references and general, abstract concepts constructed as defenses, is replaced by deeper insight that leads patients to question their entire personal histories and thinking. This happens, for example, when patients, after making defensive comments about oedipal conflicts, relive and reabsorb their own oedipal dramas. In such cases the economic and dynamic charge of such a shift and the accompanying emotions run far deeper than mere intellectual understanding.

Insight indicates a transition from the preconscious to the conscious. Attentive analysts will often anticipate a coming moment of insight, though they may feel that interpretation would be premature so long as the moment has not yet arrived. When they sense that the moment is truly imminent, they may choose to facilitate the revelation by intervening.

When assessing whether psychoanalysis is indicated during initial consultations, evaluating a patient’s capacity for insight is especially important. The capacity for insight must likewise be taken into account in gauging whether an analyst in training has yet been adequately analyzed.

ROGER PERRON

*See also:* Analyzability; Initial interview(s); Introspection; Projective identification.

### **Bibliography**

Blacker, Kay Hill. (1981). Insight (panel). *Journal of the American Psychoanalytic Association*, 29, 659–672.

Freud, Anna. (1959). *The psychoanalytical treatment of children: Technical lectures and essays*. New York: International Universities Press.

Schafer, Roy. (1978). *Language and insight*. New Haven, CT: Yale University Press.

### **Further Reading**

Kris, Ernst. (1956). On some vicissitudes of insight in psychoanalysis. *International Journal of Psychoanalysis* 37, 445–455.

Poland, Warren S. (1988). Insight and the analytic dyad. *Psychoanalytic Quarterly*, 57, 341–369.

Rangell, Leo. (1981). From insight to change. *Journal of the American Psychoanalytic Association*, 29, 119–142.

Valenstein, Arthur F. (1981). Insight as an embedded concept in early historical phase of psychoanalysis. *Psychoanalytic Study of the Child*, 36, 307–318.

---

## **INSTINCT**

The notion of *instinct* is usually linked to the field of ethology or the psychology of animal behavior. It corresponds to a specific program of action for a species that is genetically transmitted and theoretically independent of individual experience. Given a particular situation, this programming activates a specific set of neurophysiological and endocrine responses. Modern research in ethology tends to limit the exclusive role of heredity in the determination of instinct and focus instead on the role of epigenesis.

In Sigmund Freud’s work, and thus in psychoanalysis, the notion of instinct must be discussed on the one hand in terms of its differentiation from the notion of the drive and on the other hand in its own, animal acceptance.

Instinct falls under the category of what is inherited, that is, within the history of a species. By contrast, the drive belongs to the subject’s individual history. In fact, it is the fundamental vector of that history. In mental life, it is experienced through representatives, which in the course of psychical processes are differentiated into ideational representatives of objects and words, on the one hand, and representatives of affects on the other. Anchored in the somatic, the drive becomes psychical in its trajectory from its source to its aim. Among its characteristics, its capacity to trace a progressive course towards a real satisfaction or a regressive course towards a hallucinatory satisfaction offers the subject a flexibility of functioning that contrasts with the relative rigidity of instinct.

On several occasions, Freud hypothesized the existence in human beings of a collection of instincts analogous to those of animals. These instincts would form the kernel of the unconscious; and primal fantasies, as the inherited representative images of phylogenesis, would flow from them. For Freud, the instinct exists as a preliminary phase, before that of the drive, and during a process of psychical disturbance, the drive could revert to the level of instinct. Current studies of



psychosomatic disorders emphasize just such a “regressive” return to instinct.

CLAUDE SMADJA

*See also:* Drive/instinct; Ethology and psychoanalysis; Primal fantasies.

### **Bibliography**

Freud, Sigmund. (1915c). Instincts and their vicissitudes. *SE*, 14: 109–140.

———. (1915e). The unconscious. *SE*, 14: 159–204.

———. (1918b [1914]). From the history of an infantile neurosis. *SE*, 17: 1–122.

---

**INSTINCT/DRIVE.** *See* Drive/instinct

---

### **“INSTINCTS AND THEIR VICISSITUDES”**

Written between March 15 and April 4, 1915, and immediately published, *Instincts and Their Vicissitudes* opens the “collection which I originally intended to publish in book form under the title ‘Preliminaries to a Metapsychology.’ . . . The intention of the series is to clarify and carry deeper the theoretical assumptions on which a psycho-analytic system could be founded” (Freud, 1917d, p. 222 n.).

The previous year, 1914, Freud’s introduction of narcissism and of the ego as a libidinally cathected agency altered the dynamics of the psychic conflict between sexual drives and ego drives (self-preservation), leading to “the second step in the theory of the drives” (1920g). In 1924 Freud grouped “Instincts and Their Vicissitudes” with the “Metapsychology” collection of twelve essays, five of which were published. The first translations appeared in Spanish in 1924, in English in 1925, in French in 1936, in Italian in 1972, and in Portuguese in 1974.

Freud began elaborating his metapsychology under the notion of the dynamics of the psyche. He established the drive as a concept. Prior to this he had been theorizing about one or more drives. The continuing pressure of the drive, as a “measure of the demand for work that it represents,” became the “very essence” of the drive (Freud, 1915c, p. 122). Freud then theorized

about the complex relationships among autoeroticism, the sexual drives, narcissism, and the dynamic genesis of the ego. The sexual drives, early defenses belonging to narcissistic organization, have two destinies that result in the work demanded by the drive: reversal in the opposite direction and turning against the self. The former destiny splits into another two movements: turning a drive away from activity toward passivity, which combines with turning against the self, and reversing content, the only instance of which is the transformation of love and hate. Freud’s study (1915c) then gives a new analysis of sadism/masochism, voyeurism/exhibitionism, and love/hate as pairs of opposites.

The opposition of pairs is an evolving process that starts from autoeroticism as a narcissistic formation. This opposition is subject to the active, reflective, and passive expressions of the drives, from which objects and a “new subject” emerge. The genesis of the ego thus contributes to the biological polarity of psychic life, activity/passivity, which is expressed in the ambivalence of the drive impulses.

Love and hate introduce ambivalence of feeling. Again, the opposition proves complex. Freud explained how the opposition depends on the economic polarity of pleasure/unpleasure and the real polarity of ego/external reality in the dynamics of the psyche. Loving follows from pleasure; hating from unpleasure. The initial ego/reality opposition (or internal/external reality opposition) differentiates internal and external according to a sound objective criterion—the internal being the continuing pressure of the drive, which is inescapable, and the external being subtle stimuli that can be avoided. This opposition mutates into a purified-pleasure-ego under the influence of the pleasure principle in the narcissistic position. Then ego and pleasure correspond, and external world and unpleasure correspond. “At the very beginning, it seems, the external world, objects, and what is hated are identical” (1915c, p. 136). Freud then demonstrates the role of hate as a constituent in affirming and preserving the ego, as well as the autonomy of hate in relation to love.

As a pivotal text among Freud’s works, “Instincts and Their Vicissitudes” and the essays that follow do not entirely succeed. “What has happened to my *Metapsychology*? In the first place it has not yet been written. . . . But if I still have ten years to live . . . , then I promise to make further contributions to it. A first example of

this will be found in an essay of mine entitled *Beyond the Pleasure Principle* [1920g];” Freud wrote to Lou Andreas-Salomé on April 2, 1919 (1966a/1972, p. 95). In fact, this “third step in the theory of the instincts” (1920g, p. 59) enabled Freud to elaborate various themes identified or developed in that study: the relation of the drive to biology, the problem of masochism and pain (Freud, 1924c), the polarities of sexual psychic life, the addition of the phallic/castrated opposition to the active/passive and masculine/feminine oppositions (Freud, 1923e), a more sophisticated morphodynamics of the ego (Freud, 1925h), and how hatred leads to the death drives.

“Instincts and Their Vicissitudes” was a source of inspiration for Freud and his successors. It is essential to understanding the work of Melanie Klein and Jacques Lacan, as well as André Green’s discussion of how the drives intersect in their expression, for example. It is also central to understanding the drive and the ontogenesis of the ego in psychoanalysis.

MICHÈLE PORTE

*See also:* Psychosomatic limit/boundary; Defense mechanisms; Drive/instinct; Love; Metapsychology; Primary need; Purified-pleasure-ego; Self-preservation; Subject of the unconscious.

### Source Citation

Freud, Sigmund. (1915c). Triebe und Triebchicksale. *Internationale Zeitschrift für (ärztliche) Psychoanalyse*, III, p. 84–100; *G.W.*, X, p. 210–232; Instincts and their vicissitudes. *SE*, 14: 117–140.

### Bibliography

- Freud, Sigmund. (1917d [1915]). A metapsychological supplement to the theory of dreams. *SE*, 14: 219.
- . (1920g). Beyond the pleasure principle. *SE*, 18: 1–64.
- . (1923e). The infantile genital organization (an interpolation into the theory of sexuality). *SE*, 19: 141–145.
- . (1924c). The economic problem of masochism. *SE*, 19: 155–170.
- . (1925h). Negation. *SE*, 19: 233–239.
- Freud, Sigmund, and Andreas-Salomé, Lou. (1966a [1912–1936]). *Sigmund Freud and Lou Andreas-Salomé: Letters*

(William and Elaine Robson-Scott, Trans.). London: Hogarth Press, 1972.

### Further Reading

- Feldman, Michael. (2000). Some views on the manifestation of death instinct in clinical work. *International Journal of Psychoanalysis* 81, 53–66.
- Hadley, June L. (1992). The instincts revisited. *Psychoanalytic Inquiry*, 12, 396–418.
- Maze, John R. (1993). The complementarity of object-relations and instinct theory. *International Journal of Psychoanalysis*, 74, 459–470.

---

## INSTINCTUAL IMPULSE

The term *instinctual impulse* (*Triebregung*), designating the initial, productive, and local form of an instinct active within the psyche, emphasizes its intrinsic emotional dynamic. *Trieb* is the “instinct” or “drive.” *Regung* means “movement of the heart or soul, a nascent feeling, a stirring of the heart, an emotion.” Literally, *Triebregung* is the “emotional momentum of the instinct.” Etymology provides us with two versions of the verb *regen*, the origin of *Regung* (and also of *Erregung*, “excitation” or “arousal”). The first means “to place upright, to raise up, to set in motion, to stir, to arouse, to irritate, to awaken, to touch, or to affect emotionally.” *Triebregung* stems from the second meaning: “to rise, to rise up, to be in erection, to prick up.” The family of words with the root *reg-* connotes activity and movement *in action*, often in their initial stages: a desire that “pricks up” becomes *rege* in German. Sigmund Freud coined other words in an analogous way.

The term “instinctual impulse” first appeared in Freud’s work “Obsessive Actions and Religious Practices” (1907b): “A deeper insight into the mechanism of obsessional neurosis is gained if we take into account the primary fact which lies at the bottom of it. This is always the *repression of an instinctual impulse* (a component of the sexual instinct), which was present in the subject’s constitution and which was allowed to find expression for a while during his childhood but later succumbed to repression” (p. 124). In “Hysterical Phantasies and Their Relation to Bisexuality” (1908a), he wrote: “Hysterical symptoms arise as a compromise between two opposite affective and instinctual impulses, of which one is attempting to bring to

expression a component instinct or a constituent of the sexual constitution, and the other is attempting to suppress it" (p. 164). He went on to specify the meanings attached to these two transference neuroses, without giving an exhaustive definition. Until around 1914, the theory of the instincts as expounded in the "Three Essays on the Theory of Sexuality" (1905d) remained quite phenomenological. Freud thus used as near equivalents for *instinct* in its partial sense the words *impulse* or *component instinct*, as well as the terms *instinctual constituent*, *part*, or *element*. The term *impulse* appeared in 1905, described in various ways: homosexual, vengeful, or repressive impulses; sexual, hostile, libidinal, tender, or perverse impulses. In "Notes upon a Case of Obsessional Neurosis" (1909d), Freud wrote of the Rat Man: "His unconscious encompasses prematurely repressed impulses, to be described as passionate or bad." Each time the word *impulse* is used, the emphasis is on the present-time effectiveness of the instinct in question and on the emotional dimension of the psychic impulse. The impulse is located in the unconscious, with the exception of the impulse of self-preservation.

At the time of the next major development in the theory of the instincts ("Instincts and Their Vicissitudes," 1915c), the concept of the "instinct" with its "pressure" was defined, and the instinctual impulse described in more detail. The former constitutes the dynamic space underlying the psyche, and the latter actualizes it. At the end of "Instincts and Their Vicissitudes," we read: "We may sum up by saying that the essential feature in the vicissitudes undergone by instincts lies in *the subjection of the instinctual impulses to the influences of the three great polarities that dominate mental life*. Of these three polarities we might describe that of activity-passivity as the *biological*, that of ego-external world as the *real*, and finally that of pleasure-unpleasure as the *economic* polarity" (p. 140). The vicissitudes of the instincts are in fact vicissitudes of instinctual impulses. Moreover, in "Thoughts for the Times on War and Death" (1915b), Freud placed "what we call our unconscious" in apposition to "the deepest strata of our minds, made up of instinctual impulses" (p. 296), whereas in "Instincts and their Vicissitudes" he maintained that "the opposition between consciousness and the unconscious has no application for the instincts." Among the four vicissitudes of the instinctual impulses, repression makes it possible to distinguish two components: an idea or group of ideas on the one hand, and the quantitative

factor, the amount of affect in the instinctual impulses, on the other. Together, they constitute the instinctual ideation that is dissociated by repression, and they meet with different fates. Instinctual impulses are also subjected to all the defensive processes and reworked, or even worked-through, by them.

The third step in the theory of the instincts does not greatly modify the notion of instinctual impulse, except for the ideas, expressed in "New Introductory Lectures on Psychoanalysis" (1933 [1932]), that "every instinctual impulse that we can examine consists of similar fusions or alloys of the two classes of instincts [Eros and aggressiveness]" (pp. 104–105), and that their place is the id, which "originally includes all the instinctual impulses" (p. 105).

The overall understanding relating to instinctual impulses is the same as that relating to the instincts. More narrowly, the notion of affect is very close to them, as is the question of unconscious feelings. Moreover, instinctual impulses often arise in pairs of opposites. The power of instinctual impulses is necessary for the creation of dreams; unconscious fantasies are derivatives of them; and in the final analysis, any particular psychic formation is derived from them.

The notion of the instinctual impulse has been actively criticized ever since the publication of Freud's *Complete Works*: the index, at least in the case of the German and French editions, does not generally distinguish between "instinctual impulse" and "instinct." Consequently, some passages in Freud's work are ambiguous.

MICHÈLE PORTE

*See also:* Anxiety; Boredom; Instinct; Judgment of condemnation; Lie; Reaction-formation; Repressed; Repression; Slip of the tongue; Unconscious, the.

### **Bibliography**

- Freud, Sigmund. (1907b). Obsessive actions and religious practices. *SE*, 9: 115–127.
- . (1908a). Hysterical phantasies and their relation to bisexuality. *SE*, 9: 156–166.
- . (1915b). Thoughts for the times on war and death. *SE*, 14: 273–300.
- . (1915c). Instincts and their vicissitudes. *SE*, 14: 109–140.
- . (1933a [1932]). New introductory lectures on psycho-analysis. *SE*, 22: 1–182.

## INSTINCTUAL REPRESENTATIVE

In “Drives and Their Vicissitudes” (1915c), Freud defined the drive as a “concept on the frontier between the mental and the somatic, as the psychical representative of the stimuli originating from within the organism and reaching the mind” (pp. 121–122). In “Repression” (1915d), he added that this representative must be considered as made up of two components, the representative proper, or the ideational representative, and a charge of energy, the “quota of affect” (p. 152). The vicissitudes of these two components can differ markedly. Strictly speaking, only the first is submitted to repression. Psychical life is chiefly constituted by the binding and unbinding of these two components, and the psychoanalytic cure aims at reopening this process. Freud put it this way: the instinctual representative is “an idea or group of ideas which is cathected with a definite quota of psychical energy (libido or interest). . . . [B]esides the idea, some other element representing the instinct has to be taken into account. . . . [The quota of affect] corresponds to the instinct in so far as the latter has become detached from the idea and finds expression, proportionate to its quantity, in processes which are sensed as affects. From this point on, in describing a case of repression, we shall have to follow up separately what, as the result of repression, becomes of the *idea*” (p. 152). Three different vicissitudes of this “quantitative factor” can be distinguished: “[E]ither the instinct is altogether suppressed, so that no trace of it is found” (p. 153)—this first option leads to what Charcot called “*la belle indifférence des hystériques*” (p. 156). Or “it appears as an affect which is in some way or other qualitatively coloured, or it is changed into anxiety” (p. 153).

Thus there appears to be a contradiction between these two texts, in spite of the fact that they come from the same year, 1915. This contradiction was pointed out by Jean Laplanche and Jean-Bertrand Pontalis in their article on the “psychical representative” in *The Language of Psychoanalysis* (1967), and it is illustrated in the two passages quoted above. According to the first, the drive is a psychical “representative,” while according to the second, it is “represented” in the psyche by two different components, the ideational representative and the quota of affect.

It could be said that Freud is only guilty of clumsy expression or confusion of terms. In fact, it is a matter

of two different sets of difficult problems that he sought to solve in 1915. The first concerns the notion of representation, which is highly ambiguous. The second is the definition of the drive as a “frontier concept,” which has never ceased to cause problems for everyone from Freud on—to the point that its usage in psychoanalysis has been challenged (Widlöcher, 1986). Any possible path towards a solution must certainly reaffirm the character of the drive as an indispensable notion in the metapsychological edifice and acknowledge that it involves the “interface” between the somatic and the mental. Thus it is an intermediary phase in a sequence that runs from (bodily) excitation to the drive to representatives (ideational representative and quota of affect)—a sequence in which the drive is simultaneously “representing” and “represented” (Green; David).

ROGER PERRON

*See also:* Psychical representative.

### Bibliography

- David, Christian. (1985). À propos de la représentance de l'affect. *Revue Française de Psychanalyse*, 69, 3, 797–806.
- Freud, Sigmund. (1915c). Instincts and their vicissitudes. *SE*, 14: 109–140.
- . (1915d). Repression. *SE*, 14: 141–158.
- Green, André. (1985). Réflexions libres sur la représentation de l'affect. *Revue Française de Psychanalyse*, 69, 3, 773–788.
- Laplanche, Jean, and Pontalis, Jean-Bertrand. (1973). *The language of psycho-analysis*. (Donald Nicholson-Smith, Trans.) New York: Norton.
- Widlöcher, Daniel. *Métapsychologie du sens*. Paris: P.U.F., 1986.

## INSTITUT CLAPARÈDE

The Institut Claparède is a treatment and consulting center. Its objectives are “the diagnosis and treatment of mentally maladjusted children whose maladjustment is associated with neuropsychic disturbances or behavioral disturbances likely to benefit from medical therapy, medical and psychological re-education, psychotherapeutic re-education, or even specialized psychopedagogical re-education under medical control.” It is one of the Centres médico-psychopédagogique (Medical and Psychopedagogical Centers), which, since 1956, have

been monitored by the Direction d'action sanitaire et sociale (Department of Health and Social Activity) and financed by the French health care system.

A thousand families and children are treated each year. The institute has been active since 1949. In 2001 it had a team of 23 psychoanalysts, including 21 child psychiatrists, and 24 psychologists and re-educators working with 5 social workers. When the institute was created, the inclusion of child psychoanalysis added a new understanding of educational and adaptive problems in terms of the precursors of the evolution of personality. Specialized teams of psychoanalysts provide appropriate treatment to patients of all ages (up to twenty-one or older) through conventional psychoanalysis and various forms of analytic psychotherapy: psychodrama, family therapy, couples therapy, group therapy. The institute's activity provides a psychoanalytic dimension to various activities in the field of child psychiatry, education, and maternal and infant protection.

SIMONE DECOBERT

See also: France.

### **Bibliography**

Association des centres psychopédagogiques. (1954). *Rapport sur l'activité des premiers centres psychopédagogiques à Paris (Claude-Bernard), Strasbourg et Mulhouse*. Paris: Association des centres psychopédagogiques.

Association française pour la sauvegarde de l'enfance et de l'adolescence. (1959, May–June). Problème d'un centre médico-psychologique: l'institut Claparède. *Sauvegarde de l'enfance*, 5–6.

———. (1989, May–June). Travaux de l'institut Claparède: quarante ans d'existence. *Sauvegarde de l'enfance*, 3.

Chabanier, Jacques. (1988). *Le centre médico-psychopédagogique: son histoire, sa pratique, ses valeurs*. Paris: Paidós–Le Centurion.

---

## **INSTITUT MAX-KASSOWITZ**

From 1886 to 1896 Sigmund Freud was responsible for the department of nervous diseases at the Erstes Öffentliches Kinder-Krankeninstitut in Vienna (First Public Institute for Sick Children), known as the Max-Kassowitz Institute after its founder and director. Freud saw patients there three times a week without pay. The institute was founded in 1788 to provide free

treatment to sick children of impoverished families as part of a public health program begun by Emperor Joseph II. It was the second children's clinic of its kind in Europe, the first being the Dispensary for Sick Children in London (1769).

Max Kassowitz (1842–1913), a professor of pediatrics in Vienna, took over management of the facility in 1882. A specialist in the physiology and pathology of bone formation, in 1883 he introduced a method for treating rickets using phosphorous in cod liver oil.

In 1886 the institute had only two rooms: a waiting room and a consulting office (Steindlgasse 2). That same year the institute inherited two new facilities from the Kassowitz family (Tuchlauben 8) and created two departments of internal medicine and five departments for specializations: surgery (Richard Wittelshöfer and later Ignaz Rosanes), dermatology (Eduard Schiff), nervous diseases (Sigmund Freud), ears (Josef Pollak), and nose and throat (Eduard Ronsburger). In 1889 a new department for eye diseases was created (Leopold Königstein); in 1894 the second department of internal medicine added a new doctor (Oskar Rie). All these “departments” provided care, as they would in a dispensary. Aside from the director and doctors, there were medical assistants (including Ludwig Rosenberg and Max Kahane). None of these positions was salaried. For the doctors the job had the advantage of providing access to a wide range of clinical material. In 1886 there were approximately 6000 office visits, which rose to 12,839 in 1892, and to 17,400 in 1898.

The possibility of working with children led Freud to travel to Paris and Berlin in 1885–1886. In Berlin he studied pediatrics with Professor Adolf Baginsky. In 1886, as privat-docents, Wittelshöfer, Schiff, and Freud asked the teachers college of the University of Vienna for authorization to provide lessons at the institute, an authorization that had been given to Kassowitz himself, using clinic patients for their demonstrations. Authorization was refused in order to maintain the distinction between university clinics and the institute. However, Freud gave—or at least publicized—lessons “on the nervous diseases of children with demonstrations” during the summer months of 1887, 1888 (near the institute), 1891, 1892, and 1893 (at an unknown location). Under Kassowitz's leadership the institute engaged in

considerable scientific activity and, in 1890, published a collection of articles entitled *Beiträge zur Kinderheilkunde aus dem I. öffentlichen Kinder-Krankennstitute in Wien* (Contributions to children's medicine based on research conducted at the first public institute for sick children in Vienna).

Freud's scientific activity was at the time directed exclusively at infantile cerebral palsy, with the single exception of a study on infantile enuresis. Between 1886 and 1892 he collected two-hundred seventy-five neuropathological observations on diplegia in children under ten years of age, which served as the clinical basis for nine publications during the years 1888–1900. These included three monographs, including the one he presented in 1897 to the prestigious collection "Spezielle Pathologie und Therapie," directed by Hermann Nothnagel. At the time Freud was considered to be one of the principal authorities on infantile cerebral palsy.

In 1896 Freud's position was turned over to Emil Redlich, who in 1898 in turn passed it on to Julius Zappert. In 1938 the institute celebrated its one-hundred-fiftieth anniversary with a publication that proudly stated that among its collaborators was "Sigmund Freud, a great thinker and the man who discovered psychoanalysis." The institute was dissolved that same year, following the annexation of Austria by the Third Reich.

CARLO BONOMI

See also: Rie, Oskar.

### **Bibliography**

- Bolzinger, André. (1997). Freud pédiatre et antipédiatre. *Le Coq-Héron*, 146, 61–69.
- Bonomi, Carlo. (1994). Why have we ignored Freud the "Paediatrician?" *Cahiers psychiatriques genevois, Special Issue*, 55–99.
- Gicklhorn, Josef, and Gicklhorn, Renée. (1960). *Sigmund Freuds akademische Laufbahn*. Vienna-Innsbruck: Urban & Schwarzenberg.
- Hochsinger, Carl. (1938). *Die Geschichte des ersten öffentlichen Kinder-Kranken-Institutes in Wien während seines 150jährigen Bestandes 1788–1938*. Vienna: Verlag des Kinder-Kranken-Institutes.
- Jones, Ernest. (1953). *Sigmund Freud: Life and work*. London: Hogarth Press.

## **INTEGRATION**

Donald Woods Winnicott distinguished three major maternal functions in his study of the role of the environment in the processes of maturation of the infant's ego: *holding*, which conditions the integration process; *handling*, which makes possible "personalization" or "psyche indwelling in the soma"; and lastly, *object-presenting*, which underlies the building of the earliest object relations.

Winnicott essentially expounded the notion of integration in two important papers: "Primitive Emotional Development" (delivered at the November 28, 1945 meeting of the British Psychoanalytical Society) and "Ego-integration in Child Development" (1962).

Integration presupposes the existence of an initial state of nonintegration, on the basis of which the individual, not yet differentiated from his or her environment, tends to become organized into a unique being by the coming together of multiple varied and fragmented experiences. In *Winnicott* (1981), Claude Geets described the process in these terms: "These early experiences are at first sensory and motor: that which will become an I is at this point only a mass of dispersed, unconnected sensations. At the end of the integration process, there is what Winnicott calls the establishing of a unitary self: the subject (from now on) has the sense of existing as an individual entity" (p. 73).

Two types of experiences intervene in the transition from primary nonintegration to successful integration: first, the care the infant receives, "whereby an infant is kept warm, handled and bathed and rocked and named" (Winnicott, 1945/1958, p. 140), and second, the acute instinctual experiences that "tend to gather the personality together from within" (p. 140). Indeed, Winnicott very strongly emphasized the effects of the encounter between the (future) subject and the object, the impact of which is central, according to him, in the constitution of the infant's self.

Nonintegration thus has a natural place in the course of the individual's development, and every individual temporarily returns to that state during moments of rest, relaxation, or dreams, provided that he or she has enough trust in the environment to yield to this regressive movement. Winnicott linked creativity and artistic experience in adults to the ability to remain in contact with this nonintegrated, primitive

self, just as the subject must be able to experience a return to a state of nonintegration in psychoanalysis.

Nonintegration is thus a positive, structuring phenomenon that must be clearly distinguished from disintegration of the personality (or fear of disintegration). The latter is to be situated within the realm of psychopathology as a modality of defense against a return to a state of nonintegration, for in Winnicott's view, madness is never a regression, but instead a last, pathetic resort against regression.

BERNARD GOLSE

*See also:* False self; Good-enough mother; Handling; Holding; Paranoid-schizoid position; Self (true/false).

### **Bibliography**

Geets, Claude. (1981). *Winnicott*. Paris: Éditions Universitaires J.-P. Delarge.

Squiggle Foundation. (1988). *Winnicott studies. The journal of the Squiggle Foundation. A celebration of the life and work of Marion Milner, No. 3*. London: Squiggle Foundation, 1988.

Winnicott, Donald W. (1958). Primitive emotional development. In *Collected papers: Through paediatrics to psychoanalysis* (pp. 145–156). London: Tavistock Publications. (Reprinted from *International Journal of Psycho-Analysis*, 26 (1945), 137–143.)

———. (1965). Ego-integration in child development. *The maturational processes and the facilitating environment* (pp. 56–63). London: Hogarth and the Institute of Psycho-Analysis. (Original work published 1962)

---

## **INTELLECTUALIZATION**

Intellectualization is the use of the intellect to defend against instinctual impulses. Obsessive neurotics use intellectualization in an effort to master obsessive representations and exhaust themselves in an intellectual activity that is as intense as it is empty, forcing themselves against their will to scrutinize and speculate as if the most important and vital personal issues were at stake. We must not confuse this sexualization of thought, which resembles indefinitely prolonged and fruitless masturbation, that one can drive from intellectual beauty.

In *Leonardo da Vinci* (1910c) Freud gave a prototype of intellectualization in its defensive function: “His affects were controlled and subjected to the

instinct for research; he did not love and hate, but asked himself about the origins and significance of what he was to love or hate” (p. 74). For Freud, this conversion of instinct into intellect had several consequences. First of all, it is by no means certain that reconversion in the reverse direction is possible, thus leaving the world of affects out of reach. In addition, “investigating has taken the place of acting and creating as well” (p. 75). These arguments are quite surprising, because Freud had earlier demonstrated in relation to “paths of reciprocal influence” (1905d) the interaction between thinking activity and sexual excitation. Freud's interpretation of da Vinci is also surprising because it contradicts what we know about Leonardo's creative power and his passion for it. However, while the example Freud chose may pose a problem, in *Leonardo* Freud was painting a picture of the passion for investigation with which he himself was not unfamiliar.

We find intellectualization more commonly in special instances of painful and incessant mental work, which can take the extreme form that psychiatrists call *intellectual rumination*. Pierre Janet describes it in the following terms: “It is a singular labor of thought that accumulates associations of ideas, interrogations, questions, innumerable research, in such a way as to form an inextricable labyrinth. The work is more or less complicated depending on the intelligence of the subject; but whether he goes round in a circle or goes off on branches, he never reaches a conclusion, he can never hold course and exhausts himself in a work that is as interminable as it is pointless” (1909). The distinctive feature of intellectualization is in fact its pointless and infinite character. Freud partly explains this through the fact that it is not the content of the thought that is pursued, but its pure mechanism. Speaking of mental rumination in relation to the Rat Man, he noted “The thought process itself becomes sexualized, for the sexual pleasure which is normally attached to the content of thought becomes shifted on to the act of thinking itself, and the satisfaction derived from reaching the conclusion of a line of thought is experienced as a sexual satisfaction” (1909d).

We may wonder whether speaking of a “conclusion of a line of thought” in such a case is not contradictory, a contradiction we already found in *Leonardo*, when Freud spoke simultaneously of the “feeling that comes from settling things in one's mind and explaining them” (1910c, p. 80), and “the fact that this

brooding never ends and that the intellectual feeling, so much desired, of having found a solution recedes more and more into the distance” (p. 80). For Freud, obsessive intellectualization is by no means a gauge of intellectual development, which is in fact redirected for the purposes of combating the instincts and very often disappears once repression has acquired the upper hand.

Intellectualization does not derive from the sublimation of an instinct, like the pleasure of thinking, but on an idealization. Freud could thus write: “The struggle which once raged in the deepest strata of the mind, and was not brought to an end by rapid sublimation and identification, is now continued in a higher region, like the Battle of the Huns in Kaulbach’s painting” (1923b).

SOPHIE DE MIJOLLA-MELLOR

*See also:* Ideology; Interpretation; *Leonardo da Vinci and a Memory of his Childhood*; Obsessional neurosis; Rationalization; Thought.

### **Bibliography**

- Freud, Sigmund. (1905d). Three essays on the theory of sexuality. *SE*, 7: 123–243.
- . (1909d). Notes upon a case of obsessional neurosis. *SE*, 10: 151–318.
- . (1910c). Leonardo da Vinci and a memory of his childhood. *SE*, 11: 57–137.
- . (1923b). The ego and the id. *SE*, 19: 1–66.
- Janet, Pierre. (1909). *Les névroses*. Paris: Flammarion.
- Mijolla-Mellor, Sophie de. (1992). *Le plaisir de pensée*. Paris: Presses Universitaires de France.

### **Further Reading**

- Kestenbaum, G.I. (1983). Toward a definition of intellectualization. *Psychoanalysis and Contemporary Thought*, 6, 671–692.

---

## **INTERGENERATIONAL**

In psychoanalysis, the term *intergenerational* refers to a process allowing for the recognition of the modalities of conflict that situate a human being in relation to the generations that preceded that individual’s birth. The specifically psychoanalytic meaning of this notion has

to do with its articulation with the essential psychoanalytic concepts and methodological conditions that made possible the discovery of the unconscious. To avoid reification of this concept, it is preferable to use the word only as an adjective.

This term is a derivative of *transgenerational*, a term that came out of family systems therapy (Boszormenyi-Nagy, Ivan, 1973); it appeared in France around 1985 in connection with the notions of inheritance, transmission, and genealogy (Guyotat, Jean, and Fédida, Pierre, 1985; Eiguier, Alberto, 1987).

In the heterogeneity of its uses, this word served as a catalyst for the recognition of a problematic that numerous psychoanalysts had been working on for years: the presence of ideas coming from an “other” who from the outset participates with his or her own unconscious psyche in the constitution of the subject’s psychic apparatus.

It is not sufficient to observe empirically the involvement of three generations to speak of intergenerational phenomena from a psychoanalytic point of view. In fact, this notion involves a parental and grandparental intrapsychic agency that is distinct from the real, material parents and grandparents and that can hinder recognition of the differences between generations, sexual difference, and otherness.

By way of a precursor to this notion, let us recall Sigmund Freud’s statement, in “New Introductory Lectures on Psycho-Analysis” (1933a [1932]): “Thus a child’s super-ego is in fact constructed on the model not of its parents but of its parents’ super-ego; the contents which fill it are the same and it becomes the vehicle of tradition and of all the time-resisting judgements of value which have propagated themselves in this manner from generation to generation” (p. 67). It is precisely this parental agency that is revealed in the process of reconstruction.

To the extent that there is revealed “a third party of the other” situated in the generation of a grandparent (or an ancestor), it is possible to study the way in which the history that preceded the subject’s conception comes into play in the formation and development of the psyche. Thus, for example, René Kaës (1993) examined Freud’s work in terms of inheritance and transmission, and attributed to the group the role of mediator. Jean Guillaumin, for his part, studied the object loss in Freud’s work (1984, 1988).



This whole problematic presupposes the sequence genealogy/transmission/transference/reconstruction of unconscious ideas. This is why the term *intergenerational* is preferable to *transgenerational* (see also Alain de Mijolla, 1999, 2004). The operation that best exemplifies the link among generations is that of unconscious identification. The concept of unconscious identification is articulated together with other, complementary psychoanalytic notions and must be situated in the specific context of each author.

Among the works that are precursors to this problematic, the following can be cited: Sándor Ferenczi's work (1932) on the confusion of tongues and Jean Laplanche (1984) on the enigmatic signifier, in relation to the theme of the adult's message to the child; around the theme of the mirror, Jacques Lacan's foundational article on the mirror stage (1949), Donald Winnicott on the mother's mirroring role (1967), and André Green on the dead mother (1983); and lastly, focusing in the conditions of the appearance of psychotic thinking, Enrique Pichon-Rivière's work on internalization of the social bond and the psychotic as word-bearer of the family (1957–1962); Wilfred R. Bion's formulations on the functions of containment and transformation (1963–1965); the concept of blank psychosis (Jean-Luc Donnet and André Green, 1973); and Piera Aulagnier's work on failures in the maternal function as word-bearer and the prohibition imposed against thinking (1964, 1975, 1984).

A great many authors have approached the “intergenerational” (or “transgenerational”) from different perspectives, even though for the most part they have not used this term. The following contributions can be considered as coming out of this problematic: on the three generations of man in religious myth and genealogy (Guy Rosolato, 1967); on phantoms, the crypt, and the unavowable secret (Nicolas Abraham and Maria Torok, 1961–1975, 1978); on identification fantasies (Rimbaud and Freud) and the genealogy of fantasies (Alain de Mijolla, 1975, 1981, 1985, 2004); on confusion between birth/death and narcissistic lines of descent in psychopathology (Jean Guyotat, 1980, 1991, 1995); on alienating narcissistic unconscious identifications and the telescoping of generations (Haydée Faimberg, 1981, 1985, 1988); and on delusional inheritance (Micheline Enriques, 1984, 1986, 1987) as a consequence of the prohibition against thinking.

Continuing the line of inquiry in the work of Abraham and Torok, Serge Tisseron (1985, 1990, 1992,

1997) studied the creation of images as witnesses to family secrets, and Cl. Nachin studied the pathology of mourning (1981, 1989). Jean-José Baranès (1984, 1986, 1993) examined the possibility of formulating a “transgenerational metapsychology.” Alberto Eiguer (1987, 1997) conceptualized the “transgenerational object” in family therapy. With reference to observation of early relationships, Serge Lebovici (1980, 1995) spoke of a “transgenerational mandate.”

Other authors have studied the transmission of traumas in historical contexts: the Shoah (M. Bergman and M. Jucovy, 1982) and the assignment of names (Y. Gampel, 1982, 1986); vampire identifications (Pérel Wilgowitz, 1991); and Armenian genocide (Jeanine Altounian, 1991).

The terms *intergenerational* and *transgenerational* appeared relatively recently. The concept they cover can be applied to a variety of different theoretical domains. The psychoanalytic relevance of this concept can be put to the test through a retroactive reexamination of studies that made it possible to think the relationship among generations, even if it potentially means having to change or make more precise the term itself. It is thus possible to envision comparing it with the two Freudian models of the unconscious: the unconscious as a specific agency, or as the consequence of a primal repression in which an “other” takes part.

Analytic experience was the basis for the following definition, proposed by Faimberg in “À l'écoute du télescope des générations: pertinence psychanalytique du concept” (1988; Listening to the telescoping of generations: psychoanalytic relevance of the concept): The intergenerational relationship refers to a process of (re)construction that brings the primal into existence through deferred action, in the history of the transference. This primal, always fragmentary and hypothetical, then becomes the condition of possibility for initiating a process of historicizing the subject in relation to two or more previous generations. This process of links among generations can be mediated by means of an unconscious identification that is revealed in the same process of reconstruction.

This conceptualization of the intergenerational relationship does not aim to find out whether it is necessary to go back ever earlier in time. It is centered around the transference, the process of listening to the anachronisms of the unconscious, and (re)constructing historical truths. Accordingly, to avoid the risk of

finding only material that had already been put there, it does not aim to anticipate, based on known events, what might be brought to light through the analytic process. Further, the “intergenerational” concepts that result from the necessary work of transformation linked to the transference situation can by no means be substituted for it without becoming univocal explanatory schemes. Only by avoiding any such reification is it possible to listen to the unconscious there where it speaks: in a place where neither the analysand nor the analyst expected it.

HAYDÉE FAIMBERG

*See also:* Family.

### **Bibliography**

- Eiger, Alberto. (1987). *La Parenté fantasmatique*, Paris: Dunod.
- Faimberg, Haydée. (1985). Le télescopage des générations, à propos de la généalogie de certaines identifications. *Revista de Psicoanálisis*, 42, 5, 1043–1056.
- Guyotat, Jean, and Fédida, Pierre. (1985). *Événement et psychopathologie*. Lyon: Simep.
- Kaës, René; Faimberg, Haydée; Enriquez, Micheline; et al. (1993). *Transmission de la vie psychique entre générations*. Paris: Dunod.
- Mijolla, Alain de. (1987). Unconscious identification fantasies and family prehistory. *International Journal of Psychoanalysis*, 68, 397–403.
- . (2004). *Préhistoires de famille*. Paris: Presses Universitaires de France.
- Tisseron, Serge, et al. (1995). *Le psychisme à l'épreuve des générations: clinique du fantôme*. Paris: Dunod.

## **INTERNAL REALITY/EXTERNAL REALITY**

An individual's internal reality corresponds to a collection of processes, representations, and affects that are essentially (but not only) unconscious, which Sigmund Freud referred to as “psychical reality.” It thus contains the representations of the world that the subject has formed, fantasies stemming from unconscious desires, and universal fantasy structures: the primal fantasies. For the analyst, it has an existence and efficiency that are comparable to physical reality.

External reality, also called material reality, subsumes the objects of our physical environment, the subject's body, and the subject's inscribed place in society.

These two concepts exist in a dialectical and sometimes paradoxical relation throughout Freud's work. They presuppose a theorization of each one taken separately and of their interconnection. In other words, what is at stake is knowing how material reality becomes internalized and how a reality that is initially completely subjective is gradually constituted as external.

In “Negation” (1925) Freud asserted, “What is bad, what is alien to the ego and what is external are, to begin with, identical” (p. 237). According to him, external reality always remains unknowable, like Immanuel Kant's *Ding an sich* (Thing-in-itself); but, like Kant, Freud did not adhere to George Berkeley's absolute idealism, which essentially holds that there exists only mental reality. Actually, such a state is only found in certain psychoses (schizophrenia, chronic delusional psychosis, etc.), in which the movements of mental reality are taken for external reality (cf. hallucination). In neurosis, these two topographical spaces remain distinct, even if “psychical reality plays a dominant role,” as Freud wrote in the *Introductory Lectures on Psychoanalysis* (1916–17b [1915–17]).

The theory of the connection between the two orders was adumbrated as early as 1891 in Freud's text “On Aphasia: A Critical Study,” where he distinguished between thing-presentations and word-presentations. The unconscious contains only *Sachvorstellungen* (thing-presentations), whereas both forms of representation are found in the preconscious and the conscious.

In elaborating the idea of mental reality Freud no doubt drew upon the teachings of the philosopher Franz von Brentano (*Psychology from an Empirical Standpoint*, 1874/1973). However, his first model can justifiably be traced back to the 1895 “Project for a Scientific Psychology,” where Freud invoked a “reality of thought [*Denkrealität*] that is autonomous although dependent upon external reality.” “Project for a Scientific Psychology,” which Jean Guillaumin has called “a wide-ranging meditation on the relationship between the Ego and the external world,” deals with material reality by introducing the concept of the “reality index,” based on the perceptual neurons capable of apprehending external reality. The actual term “psychical reality” appears for the first time in 1909 in an addendum to the second edition of *The Interpretation of Dreams*. Not until the 1919 edition was the

now-classic distinction between “psychical reality” and “material reality” finally posited.

Throughout his writings Freud attempted to specify the laws of the functioning of psychic reality and to shed light on its dialectical connection with external reality. In “Formulations on the Two Principles of Mental Functioning” (1911), he asserted that in the earliest stages of life the subject is dominated by the pleasure principle and hallucinatory satisfaction. But the failure of this as a means of attaining satisfaction forces the infant to “represent for itself the real state of the external world.” Thought, which is originally unconscious, is split: One part remains under the control of the pleasure principle and constructs fantasies; the other part, with language, becomes conscious and capable of judging whether a representation belongs to internal, psychic reality or to the external reality of the world. Thus psychic reality functions under the yoke of instinct and according to the laws of the primary processes. Unaware of time or negation, these representations and affects are displaced and condensed according to the flow of cathexis. Ever concerned with shedding light on the connections that exist between this internal reality and the external world, Freud then introduced, in “A Case of Paranoia Running Counter to the Psycho-Analytic Theory of the Disease” (1915), the idea of “primal fantasies.” These “constitute” a treasure of organizing “schemas” of all fantasies and are in a sense the hard core of psychic reality (Jean Laplanche and Jean-Bertrand Pontalis, 1985).

By postulating that the primal fantasies are phylogenetic in origin, an idea he would defend until his death, Freud re-enmeshed external reality and psychic reality. What had once been prehistoric reality later became part of psychic reality. In any case, in Freud’s view, in “An Outline of Psychoanalysis” (1940 [1938]), external reality must forever remain “unknowable,” just as a “quantity of (unconscious) processes are themselves unknowable.” He concluded this work by emphasizing the function of the internalized external world constituted by the superego that “reunites the influences of the present and the past.”

Since then, numerous psychoanalysts, inspired in particular by the writings of Melanie Klein, have developed the idea of psychic reality, most often on the basis of work on psychosis: Michael Balint, Donald Winnicott, Wilfred Bion—who emphasized the hatred the psychotic patient feels for realities—and Piera Aulagnier, with the concept of historical

reality. In France, Jacques Lacan took up this thematics with his 1953 introduction of the category of the real, as distinct from reality. In his 1975 seminar “R.S.I.,” he defined the Real as “what is impossible to subjectivize.” A stopping point for thought, it supposedly appears in psychosis and irrupts at the end of the cure.

During the same period, Serge Videman in *La Construction de l’espace analytique* (Construction of the analytical space; 1970) argued that “the reality of events is of no importance to the analyst, whose duty it is to invent it.” By stating it to the patient, the analyst in a sense brings this reality into existence. The event or its trace is argued to be at most the grain of sand around which fantasies are formed, like the pearl around an impurity. Thus Freud invented a new reality, constrained by the “epistemological necessity” of delimiting his object of study and his field of action. Although the notion of psychic reality is no longer contested today, and although all analysts recognize its heuristic value, fundamental divergences exist among the various conceptions relating to the articulation of internal and external realities.

Adherence to a physical realism has led many practitioners to invoke social and material reality from a normative perspective (Heinz Hartmann, 1956). Explaining symptoms only in terms of real events and advocating adaptation to reality are a contemporary trend in psychotherapeutic practices that retain from the analytic approach nothing but the adjective in which it is tricked out.

Another theoretical and practical current advocates the bracketing of external and historical reality (Lacan, Videman). Beyond their divergences, these theorists share the same desire to master the domain of the psyche whose purity cannot be altered by any factual opacity. Today, most analysts are in agreement on a principle of “undecidability” (Daniel Widlöcher, Jean Guillaumin, Haydée Faimberg, etc.) as to what should be attributed to material reality and what comes from psychic reality. Deeper understanding of the notion of the primal (Aulagnier) and transcultural studies show that “the infantile, culture, and the characteristic of the object,” as Maurice Dayan expressed it in *Inconscient et Réalité* (Unconscious and reality; 1985)—in other words, external reality—organize the subject’s psychic reality in their own way.

JEAN-PIERRE CHARTIER

See also: Adaptation; Animus-Anima (analytical psychology); Children's play; Collective unconscious (analytical psychology); Contradiction; Creativity; Cure; Dream-like memory; Ego; Ego autonomy; Id; Illusion; "Inconscient, (L'-)"; "Metapsychological Supplement to the Theory of Dreams"; Money and psychoanalytic treatment; Mourning; Negation; Omnipotence of thought; *Phylogenetic Fantasy, A: Overview of the Transference Neuroses*; Psychotic part of the personality; Reality testing; Real trauma; Symbolization, process of; Termination; Thought; Transitional object; Transitional object, space; Transitional phenomena.

### Bibliography

- Aulagnier, Piera. (2001). *The violence of interpretation: From pictogram to statement*. (Alan Sheridan, Trans.). Hove, UK, and Philadelphia: Brunner/Routledge. (Original work published 1975)
- Dayan, Maurice. (1985). *Inconscient et réalité*. Paris: Presses Universitaires de France.
- Freud, Sigmund. (1891b). On aphasia: A critical study. (E. Stengel, Trans.). New York: International Universities Press, 1953.
- . (1895 [1950c]). Project for a scientific psychology. *SE*, 1: 281–387.
- . (1911b). Formulations on the two principles of mental functioning. *SE*, 12: 213–226.
- . (1915f). A case of paranoia running counter to the psycho-analytic theory of the disease. *SE*, 14: 261–272.
- . (1916–17b [1915–17]). Introductory lectures on psychoanalysis. *SE*, 15–16.
- . (1925h). Negation. *SE*, 19: 233–239.
- . (1940a [1938]). An outline of psychoanalysis. *SE*, 23: 139–207.
- Lacan, Jacques. (1974–1975). Le Séminaire-Livre XXII, R.S.I. Jacques-Alain Miller (ed.). *Ornicar?*, 2–5.
- Laplanche, Jean, and Pontalis, Jean-Bertrand. (1974). *The language of psycho-analysis*. (Donald Nicholson-Smith, Trans.). New York: W. W. Norton. (Original work published 1967)
- Viderman, Serge. (1970). *La Construction de l'espace analytique*. Paris: Denoël.

### Further Reading

- Grand, Stanley. (2002). Action in the psychoanalytic situation: Reflections on its relation to internal and external reality. *Psychoanalytical Psychology*, 19, 254–280.

Kernberg, Otto. (1980). *Internal world and external reality: object relations theory applied*. New York: Aronson.

## INTERNAL OBJECT

*Internal object* refers to the mental representation that results from introjection, incorporation, or internalization of the relationship to an external object. This is reinforced by the self-representation of the representative agency engaged in that relationship, thus together giving rise to complex object relationships.

Although Freud himself never used the term “internal object,” he provided a foundation, which was then elaborated upon by Sándor Ferenczi and Karl Abraham. It was Melanie Klein, however, who proposed the original theory of an internal world with introjected objects and the ego's ambivalent relations with them. In her theoretical model (Klein 1935, 1940), the young ego split in this way experiences the threat of annihilation both from internal persecution arising from its destructive instincts and, at the same time, from reprisals by its own internal objects under attack. Ronald Fairbairn (1963), Donald W. Winnicott (1954/1958), Wilfred Bion (1962), Thomas Ogden (1987), and others subsequently offered further theoretical clarifications.

The concept of (if not the term) internal object in Freud's work originates with his paper “Mourning and Melancholia” (1916–17g). Freud suggested that during the normal mourning process, the ego introjects the loved object to maintain its close relationship with it before submitting to the reality principle and eventually acknowledging the loss. In melancholia, by contrast, investment in the loved object, which arose in the first place from a narcissistic object choice that was originally ambivalent, is withdrawn when the object is lost; but the libido, instead of being transferred to other objects, is reinvested in the ego and used to form an unconscious identification with the lost or abandoned object. Object loss becomes ego loss, and the divided ego thereafter maintains a tormented relationship with itself. Freud refers to a regression to infantile narcissism in which the subject relates to the object on an oral level; thus, identification is effected through cannibalistic incorporation accompanied by an instinctual and ambivalent struggle to detach from, or preserve, libidinal investment. Melancholia would be also associated with the superego, conceived by Freud as the internalization of parental demands upon the

ego; the superego separates itself from the ego by splitting in the course of the repression that ensues in the wake of the oedipal conflict.

After 1934, and especially with her paper “Mourning and Its Relation to Manic States” (1940), Melanie Klein took up these ideas, and introduced the notion of an internal world of introjected and internalized objects, with which the ego maintains tumultuous relations of love and destructiveness. According to Klein, the splitting of the object and the introjection of the good object are defenses of the ego when threatened with the loss of the object. This process is characteristic of the “depressive position,” during which the part-object comes to be seen by the infant as a whole object, thus susceptible to loss. In this internal world, the play of instincts will threaten the good object (the primary object, incorporated before being introjected) with destruction. But because the good object constitutes the primary core of the ego itself, the ego then fears that it will be annihilated as well. Following Freud’s model of the “purified pleasure ego” (1915c), Klein sees projection as the internal (good) object’s defense against what it experiences as bad objects, whether the feeling of unpleasure is due to frustration or resulting instinctual destructiveness.

Fairbairn’s contribution (1963) took these theories into consideration. Like Klein, he conceived of the ego as present at birth and capable of complete object relations. In case of failure of the primary object relationship, the ego splits off aspects of the self that appear undesirable to the mother, in a fixation to an unsatisfactory aspect of the object; this relation as a whole is repressed with the dual aim of mastering emotions and of creating the desired change in the object. For Fairbairn, “dynamic ego-structures” possess a certain autonomy in relation to the personality (considered as unique), and the internal object, as representative of an external object, is considered a specific agency. Thus, according to Fairbairn, the concept of the undifferentiated id is replaced by the idea of unconscious ego-object structures.

In 1954, Donald Winnicott proposed the notion of the “false self” as a defense organization developed to counter the threat of annihilation. The “false self” is a form of self-care; it energetically manages life in order to shield itself from the experience of an intense pressure to develop according to the internal logic of a primary other.

Wilfred Bion (1962) brought into play the notion of the “container” to describe the process that goes from projective identification to reintroduction. He discusses the unconscious fantasy of projecting into another the undesirable or damaged parts of the self, which can be later reintroduced after modification by this “container.” For Bion, projective identification implies a personality split and ejection of the split-off part as an internal object. The “bizarre” object is an internal object experienced by the schizophrenic patient as having a life of its own, in an ego split such that the patient at the same time recognizes the self as a thing enclosed in the object.

For Thomas Ogden, the internal object relationship necessarily implies interaction between two divisions of the personality, each an active agency (1987). He suggests conceiving of the internal object as an aspect of the split ego, projected into and identified with an object representation. As an active agency able to produce meaning, this suborganization identified with the object works as a self-representation, which corresponds to the representation of the object. The relation to the internalized object implies thenceforth a double cleavage of the ego, because another ego suborganization remains identified with the self and maintains the object relationship.

Maria Torok’s contribution, “The Illness of Mourning and the Fantasy of the Exquisite Corpse” (1968/1994), also deserves mention here. For this author, what is introjected is not the object, but the ensemble of drives and their vicissitudes for which the object serves as occasion and mediator. Here the goal here is to subjectify, to introduce into the ego unconscious, anonymous, or repressed libido. Torok distinguishes the internal object from the imago; the former represents one pole for the process of introjection while the latter represents everything that the ego appropriated through fantasies of incorporation, bringing together everything that had resisted introjection. Such an imago of fixation develops from a failed introjective relationship with an external object, and acts to prohibit sexual desire. Beyond the object, desire is lost, buried in an “endocryptic” identification.

The nature of the internal object remains an open discussion. Melanie Klein’s theoretical propositions lacked clarity, based as they are on attributing literal reality to unconscious phantasies and on postulating agencies that are capable of feeling, thinking, and perceiving. Fairbairn clarified this issue with his suggestion that the

internal object must be considered a split-off part of the ego that remains in relation with an object that is (at least partially) a dynamic structure, but he did not explain the dynamism of this structure. Bion's notion of the "bizarre object" also brought a certain clarity to the discussion by assuming a process in which a suborganization of the ego, a consequence of a split, presents itself to itself as a "thing," and has a fantasy of being included in (part of) the object.

MARIE EUGÉNIE JULIAN MUZZO BENAVIDES

See also: Concept; Deprivation; Group analysis; Imago; Object; Projective identification.

### **Bibliography**

- Bion, Wilfred R. (1962). A theory of thinking. *International Journal of Psycho-Analysis*, 43, 4–5.
- Fairbairn, W. Ronald D. (1963). Synopsis of an object-relations theory of the personality. *International Journal of Psycho-Analysis*, 44, 224–225.
- Freud, Sigmund. (1915c). Instincts and their vicissitudes. *SE*, 14: 109–140.
- . (1916–17g [1915]). Mourning and melancholia. *SE*, 14: 237–258.
- Klein, Melanie. (1935). A contribution to the psychogenesis of manic-depressive states. *International Journal of Psycho-Analysis*, 16, 262–289.
- . (1940). Mourning and its relation to manic-depressive states. *International Journal of Psycho-Analysis*, 21, 125–153.
- Ogden, Thomas H. (1987). The transitional oedipal relationship in female development. *International Journal of Psycho-Analysis*, 68, 485–498.
- Torok, Maria. (1994). The illness of mourning and the fantasy of the exquisite corpse. In Nicolas Abraham and Maria Torok, *The shell and the kernel: renewals of psychoanalysis* (Nicholas T. Rand, Ed. and Trans.). Chicago: University of Chicago Press. (Original work published 1968)
- Winnicott, Donald W. (1958). Metapsychological and clinical aspects of regression within the psycho-analytical set-up. In *Collected papers: through paediatrics to psycho-analysis*. London: Tavistock (Original work published 1954)

### **Further Reading**

- Hinshelwood, Robert D. (1997). The elusive concept of "internal objects"(1934–43). *International Journal of Psycho-Analysis*, 78, 877–898.

Isaacs, Susan. (1940). Temper tantrums in early childhood, and their relation to internal objects. *International Journal of Psycho-Analysis*, 21, 280–293.

Ogden, Thomas. (1983). The concept of internal object relations. *International Journal of Psycho-Analysis*, 64, 227–242.

Sandler, Joseph, and Sandler, Anne-Marie. (1998). *Internal objects revisited*. London: Karnac Books.

---

**INTERNAL SABOTEUR.** See *Antilibidinal ego/internal saboteur*

---

**INTERNALIZATION.** See *Externalization/internalization*

---

## **INTERNATIONAL ASSOCIATION FOR THE HISTORY OF PSYCHOANALYSIS**

The International Association for the History of Psychoanalysis (Association Internationale d'Histoire de la Psychanalyse), a non-profit organization, was created on June 25, 1985, in Paris by Alain de Mijolla. The Association was created to provide as full an understanding as possible of the history of psychoanalysis and its founder. Its central concerns are the history of the discovery of psychoanalysis; the life of Sigmund Freud; his friends, disciples, and successors; the history of the psychoanalytic movement since its inception, including its international developments and internal divisions; the role of psychoanalysis in the history of the sciences and the intellectual life of the nineteenth and twentieth centuries; and its relation with general history and the political, socio-economic, and cultural characteristics of its time.

Through international meetings held every two years in Paris, Vienna, London, Brussels, and Berlin or Barcelona, the association has been able to promote renewed interest in the history of psychoanalysis. These meetings also led to the creation of other groups and associations devoted to the collection of archival documents and research concerning the historical evolution of psychoanalytic ideas and institutions as well as the contributions of the men and women who have, through their creativity, helped to disseminate Freudian theories.

Presentations, films, and the twice-yearly publication of the *Journal de l'A.I.H.P.* in French and English has given the Association a reputation for accuracy and openness in historical research, and independence from any allegiance to psychoanalytic schools or groups. The Association is open to all professionals and amateurs of history, whether or not they are psychoanalysts. In 2001 the Association received the Mary S. Sigourney award in recognition of its outstanding contribution to the field of psychoanalysis.

ALAIN DE MIJOLLA

### **Bibliography**

Mijolla, Alain de. (1996). Psychoanalysts and their history. *International Psychoanalysis: The Newsletter of the IPA*, 5 (1), 25–28.

## **INTERNATIONAL FEDERATION OF PSYCHOANALYTIC SOCIETIES (IFPS)**

The International Federation of Psychoanalytic Societies (IFPS) was founded in Amsterdam on July 30, 1962, by four Societies: the Deutsche Psychoanalytische Gesellschaft e. V. gegründet 1910, the Sociedad Psicoanalítica Mexicana, the Wiener Arbeitskreis für Tiefenpsychologie, and the William Alanson White Psychoanalytic Society.

The main promoter of IFPS was Erich Fromm, who also was the founder of the Mexican Society, had been excommunicated in the United States, and had lost his IPA membership. As a consequence of his many disappointments, Fromm in 1956 began to wish for the creation of a non-bureaucratic psychoanalytic association of all bona fide psychoanalysts, independently from their persuasion.

He found a sympathetic listener in Werner Schwidder, who wished to overcome the post-World War II isolation of the German Psychoanalytic Society (DPG). In Germany, under the Nazi regime, the psychoanalytic terminology had been prohibited in 1938, and the Freudian Group of the Göring Institute became officially nonexistent. After the war the DPG, which had been founded in 1910, was reconstituted anew. In 1950, however, there was a schism: the DPG lost a number of members, who founded the German Psychoanalytic Association (DPV). Apparently, the reason for the psychoanalytic war was the question of loyalty to the Freudian psychoanalytic

principles: under Müller Braunschweig, the DPV accused Felix Böhm and the disciples of Schultz-Hencke in the DPG of having sold out to the Nazi ideology by rejecting integral Freudian tenets. In 1951 the DPV was admitted to the International Psychoanalytic Association (IPA), while the application of the DPG was rejected because of its deviant psychoanalytic conception (Schultz-Hencke's contributions). When Schwidder succeeded Böhm, he tried to establish international contact. Fromm encouraged him to contact the William Alanson White Society in New York, and Schwidder, hoping for an alliance supportive of analytic "freedom of speech," pointed out in a letter to the White Society that Schultz-Hencke's work had preceded the Hitler's era.

A first open international psychoanalytic meeting took place in Amsterdam in the summer of 1960, a second one in Düsseldorf in 1961, and a year later the First International Forum of Psychoanalysis was held in Amsterdam, on the subject "Present Day Trends in Psychoanalytic Theory and Practice." A number of prominent analysts had agreed to participate at the Forum, among them Franz Alexander, Herbert Binswanger, Médard Boss, Igor Caruso, Erich Fromm, Martin Grotjahn, René Laforgue, Jack Millet, Sándor Rádo, Raoul Schindler, René Spitz, Edith Weigert, and many others. On this occasion a new "Arbeitsgemeinschaft" for promoting a free discussion of psychoanalytic theory and practice, later named IFPS, was founded at a meeting between Igor Caruso, Erich Fromm, Werner Schwidder, and Gerard Chrzanowski. Sándor Rádo, representing the American Academy of Psychoanalysis and its medical psychoanalysts policy only, withdrew from participation in the organization of the federation.

According to the Statutes, "the IFPS is committed to the concept of pluralism in psychoanalytic theory and practice as well as to the interdisciplinary exchange in matters of micro- and macro- social interest." Since 1962, the Forum has been held every four years. In nearly four decades, the IFPS organized 18 international meetings (10 fora and 8 conferences), and the member societies have risen to 22, all from Europe and America, representing about 2,000 psychoanalysts. The minimum requirement for being admitted is a regular training, consisting of three years of theoretical and clinical psychoanalytic instruction (after a full course of studies in medicine or psychology), a personal analysis (three sessions per week), and supervised psychoanalytic sessions with two different supervisors. In 1992, the *International Forum of*

*Psychoanalysis*, a quarterly journal promoted and supported by the IFPS, began to be published, and in 1996 the IFPS *Archives* for the history of psychoanalysis were established.

CARLO BONOMI

## **INTERNATIONAL JOURNAL OF PSYCHOANALYSIS, THE**

*The International Journal of Psychoanalysis* began to be published in 1920 "as an English Journal or Edition of the *Zeitschrift (Die Internationale Zeitschrift für ärztliche Psychoanalyse)*, not identical of course, owned by the Vereinigung [Internationaler Psychoanalytischer Vereinigung]," to use the words of Ernest Jones who proposed the new journal to Freud in a letter dated London the 7th of December 1918.

During Jones's rather controlling editorship, which lasted till 1939, the *International Journal of Psychoanalysis* translated and published some of the most important papers of Sigmund Freud, Anna Freud, Karl Abraham, Sándor Ferenczi, Melanie Klein and others, as well as papers by British and American psychoanalysts and by psychoanalysts from other countries. From the start, *The International Journal* contained a specific section dedicated to the review of books concerned with psychoanalysis.

Originally the aim of Ernest Jones was to create a journal which could make the British Psychoanalytic Society the leading and controlling authority in this field in the English-speaking world, eliminating the competition of the Americans, whose scientific standards Jones deeply distrusted as far as the translation of Freud's papers and the diffusion of psychoanalysis were concerned.

From 1940 to 1945, the *International Journal of Psychoanalysis* was edited by James Strachey. In 1946, it was edited by Adrian Leslie Stephen and from 1947 to 1948 by Willie Hoffer, John Rickman, and W. Clifford M. Scott. It was during this period that, due to the emigration of the Viennese and other analysts from Central Europe to England and America because of Nazi persecution, the *International Journal of Psychoanalysis* became the acknowledged official organ of the International Psychoanalytical Association (IPA), publishing the Bulletins and the business meetings of

the IPA Congresses, taking the place of *Die Internationale Zeitschrift für (ärztliche) Psychoanalyse*, which had ceased publication. In 1947, it was agreed by Anna Freud and her co-workers and by the British Psychoanalytic Society that the IPA would continue to own the heading of the International Journal of Psychoanalysis but that the British Psychoanalytic Society would become the custodian of the journal, which would be edited by a British editor at least for a while. This compromise remains in force.

Willi Hoffer edited the International Journal of Psychoanalysis from 1949 till 1959; John D. Sutherland from 1960 till 1968; Joseph Sandler from 1969 till 1978; Thomas Haley from 1978 till 1988. From 1988 till 1993 Thomas Haley edited the *International Journal of Psychoanalysis* together with David Tuckett. David Tuckett then became the editor of the *International Journal of Psychoanalysis* followed by Glen O. Gabbard and Paul Williams.

During the decades after Jones retired from the editorship, the *International Journal of Psychoanalysis* has continued its policy of translating into English the best papers of psychoanalysts belonging to the various schools, although it has had to face the increasing competition of several other periodicals of psychoanalysis, not only in English, and the complexity of the increasing multiculturalism and multilingualism of the international psychoanalytic community. To try to maintain its leadership, in 1984 Thomas Haley tried to increase the democratic participation in the editorship, which until that time had been controlled only by the British editor with the help of a North American sub editor. Haley created regional boards of sub editors, including psychoanalysts from Latin America, Europe and other parts of the world. This policy is being followed by the current editor. Since 1995, the *International Journal of Psychoanalysis* has been available on CD, and since 1997 it has been accessible on its World Wide Web site.

RICCARDO STEINER

See also: Hartmann, Heinz; *Internationale Zeitschrift für (ärztliche) Psychoanalyse*; Jones, Ernest.

### **Bibliography**

Pauskukas R.A. (Ed.). (1993). *The complete correspondence of Sigmund Freud and Ernest Jones 1908–1939*. Cambridge, MA and London: Harvard University Press.



Steiner W. (1994). The Tower of Babel or after Babel in contemporary psychoanalysis. *International Journal of Psychoanalysis*, 75, (5/6), 883–901

## INTERNATIONAL PSYCHOANALYTICAL ASSOCIATION

Throughout his lifetime Sigmund Freud was concerned to maintain the unity of the theory and practice of psychoanalysis—an enterprise that he had labored so prodigiously, so single-handedly, and for so long to create. To him, psychoanalysis was not only a science and profession, but also a movement calling for dedicated and disciplined allegiance. When confronted with the enormously painful blow of Carl Gustav Jung's defection, he readily took to the idea, which Ernest Jones claimed to introduce (1955, p. 152), of creating a secret committee of seven ring holders, a group of his geographically scattered closest friends and adherents, to try to ensure the stability of his central psychoanalytic doctrines. This desire to safeguard psychoanalysis as a unified enterprise against both destructive pressures from without and human divisiveness from within also served as a principal impetus for organizing the International Psychoanalytical Association (IPA).

At the first international congress, a scientific gathering of interested colleagues organized by Jung and held at Salzburg, Germany, in 1908, Freud presented the case of the Rat Man, a presentation that took over four hours. The outstanding success of this meeting and the growing concern over the spread of substandard psychoanalytic work by uninformed outsiders, as well as antipathies and attacks emanating from the organized medical and academic worlds, led to the official founding of the IPA during the second congress at Nuremberg in 1910. Three branch societies were recognized at this congress: Vienna, Berlin, and Zurich (Limentani, 1996). This congress was more contentious than the first one in Salzburg. Sándor Ferenczi, who actively promoted this new venture, proposed, with Freud's strong backing, that the administrative center should be Zurich (not Vienna) and that Jung should be president. To mollify the disgruntled Viennese, Freud handed the presidency of the Vienna Psychoanalytic Society to Alfred Adler and designated Adler and Wilhelm Stekel as coeditors of the newly founded official journal *Zentralblatt für Psychoanalyse*.

The first IPA congresses, up through the ninth congress in Bad Homburg, Germany, in 1925, were essentially scientific conclaves of the gradually increasing cadre of psychoanalysts, mostly in the central European heartland in which analysis first grew and thrived, but with members gradually coming from a wider geographic orbit as psychoanalytic influence slowly spread throughout Europe and even across the Atlantic. In fact, at the third, Weimar, congress in 1911, a New York group was admitted as the newly formed American Psychoanalytic Association.

At the fourth congress in Munich in 1913, organizational politics erupted. Jung agreed to continue as president despite increasing opposition by many members, less reluctant than Freud, to face Jung's growing alienation from psychoanalysis. But within a few months Jung's break became final, and he resigned his IPA membership and with it the presidency. Jung's break followed Adler's earlier defection in 1911 and was contemporaneous with other significant departures, those of Eugen Bleuler and Wilhelm Stekel. This early turmoil and the rise of alternative psychologies—Adler's individual psychology and Jung's analytical psychology—prompted Jones to propose the committee of seven (Sándor Ferenczi, Otto Rank, Karl Abraham, Hanns Sachs, and Max Eitingon, in addition to Freud and himself) to watch over Freud's creation. This committee, a major result of the tensions that periodically characterized the history of the IPA, went on meeting and corresponding until 1927.

There were only four congresses, one in Austria and three in Germany, with German the dominant language in each, before the five-year hiatus caused by World War I. When the fifth congress took place in Budapest at the end of the war in 1918, only analysts from Austria, Germany, and Hungary were able to attend. At this fifth congress Ferenczi was elected President, but unfavorable circumstances in his country soon forced him to ask Ernest Jones to take over the position. Thus began a presidency by Jones that lasted from the sixth congress in the Hague in 1920 until the sixteenth congress in Zurich in 1949 (with the exception of a nine-year period, 1925 to 1934, when Abraham and Eitingon served as president). During this period between the First and Second World Wars and under Jones's presidency, a major struggle over lay analysis took place—a struggle that nearly sundered the IPA.

Wallerstein (1998) has detailed the nearly eight-decade long struggle over the question of lay analysis within the worldwide psychoanalytic movement, from its inception in 1910 to its final resolution at the thirty-fifth congress in Montreal in 1987. In 1910 there occurred two events, seemingly totally unrelated and widely separated geographically, that were fateful for the evolution of this conflict. One, in Europe, was the publication of Freud's paper " 'Wild' psycho-analysis," expressing his alarm at the proliferating practice of psychoanalysis by the analytically uninformed. The other, in America, was publication of the famed Flexner report, which exposed the shocking state of medical education in the United States and caused in short order half the existing medical schools in the country to close their doors, with the remainder moving to emulate the preeminent German model and become the approximately 100 top-notch medical schools in the nation by the 1930s. The challenge was to exorcise charlatans from therapeutic activity and to make a proper medical degree, obtained from the fully upgraded schools, the hallmark of proper training and competence in the healing arts.

From these disparate circumstances, one can trace two divergent paths, beginning in 1910, for organized psychoanalysis. One set of developments occurred in central Europe, where Freud lived and was personally influential, and the other in North America, where as early as the second decade of the century some doctors became interested in psychoanalysis, went to Europe for personal analysis and some rudiments of training, and then returned to establish the new science in North America. The European developments were, of course, heavily colored by Freud's personal career. His new doctrines were not welcomed by the established medical and academic worlds, and for the most part, psychoanalysis in Vienna and throughout Europe had to exist as a completely private activity outside of academia and organized medicine and, in its early days, in the face of medical and public opposition. When Eitingon created the first organized training institute in Berlin in 1920 to counter the threat of "wild analysis," it was as a private night school, to which Freud and his followers welcomed all who came and wanted to learn. The majority of those attracted were physicians drawn mostly from a sterile diagnostic neurology, but others came from a great array of other disciplines, including pedagogy, psychology and other social sciences, and the humanities. From the start,

psychoanalysis in Europe was open to all who could qualify, whatever their discipline of origin.

In North America, meanwhile, matters took a different course. Under the impact of the Flexner report, the Americans felt that the integrity of analysis could be safeguarded from psychoanalytic activity by the unqualified only within the increasingly respectable and scientific medical orbit. So from the start they restricted membership in the American Psychoanalytic Association, an affiliate of the IPA, to medical psychoanalysts. Thus Europe and North America, in attempting to cope with the same issues of psychoanalytic standards and competence, embarked on diametrically opposite courses, European psychoanalysis being open to all, with standards to be maintained by rigorous training in organized institutes, and American psychoanalysis excluding all but physicians, with standards to be maintained by barring those without medical qualifications.

This fundamental clash of conceptions was brought squarely into the IPA at the ninth congress, in Bad Homburg in 1925. At this congress the IPA, for the first time, undertook to become more than a scientific congress; it sought to become as well a standard-setting voice for establishing and maintaining uniform training criteria for all psychoanalysts in the growing number of geographically scattered centers of analytic activity in the world. This was done by organizing the International Training Commission (ITC), with Eitingon as its chair. The laudable intent was to establish and monitor internationally agreed-upon standards for training modeled on those of the Berlin institute, which Eitingon established five years earlier in 1920. This measure was also intended to make psychoanalytic credentials portable as analysts emigrated from their countries of origin, which at the time meant mainly from Europe to the United States.

For the Americans at Bad Homburg, this raised the specter of immigration into the United States of nonmedical analysts with credentials from European training centers, all of which accepted nonmedical applicants on the same basis as physicians. The Americans, therefore, strongly objected to the authority of the ITC and cited American laws against quackery, which required them to exclude nonphysicians from therapeutic activity. They asked to be exempted from the regulations of the ITC and to have the right to set their own criteria for admission to training in the United States and their own criteria for acceptance

to American societies, criteria that would cover their own graduates and also immigrant analysts from Europe. Thus began a major confrontation between the Europeans and the Americans that lasted up to the onset of World War II and was only “resolved” by a compromise solution at the sixteenth congress in Zurich in 1949, the first congress after the war.

Strenuous efforts were made over the six congresses between the ninth in 1925 and the fifteenth, in Paris, in 1938, to reconcile the increasingly bitter differences between the Europeans and the Americans so that a viable ITC could function across the analytic world. But each time these efforts were unsuccessful or amounted only to temporary patchworks that promptly broke down. The matter came to a head at the fifteenth congress, in 1938, when the Americans proposed a resolution declaring that the IPA is a congress for scientific purposes alone and calling for the total dismantling of the ITC and the abrogation of any training authority in the IPA over psychoanalysis in America. They backed this up with the voiced threat that if their demands were not granted, they would secede from the IPA and split the analytic world into separate American and European hegemonies. The threat was ominous because the balance in the IPA changed considerably over the immediately preceding five years subsequent to Hitler’s accession to power in 1933. Whereas the Americans were only 20 percent of the total membership at the beginning of the 1930s, by 1938 they were quickly becoming the majority, as Hitler’s march across Europe systematically depopulated the major centers of IPA activity in central Europe, sending a tide of refugees abroad, mostly to the United States.

The threat of secession was indeed portentous: the IPA would have been split asunder, with the American part much the larger and the European part, such as still existed in 1938 after the dispersal of the Berlin and Vienna institutes, under the threat of gathering war clouds. Ernest Jones, the continuing IPA president, therefore proposed deferring a definitive vote on the American motion until the next congress, scheduled for 1940, with an injunction that all affiliated societies intensively deliberate on the issues in the hope that some viable compromise might yet emerge. But two years later, in 1940, Europe was in the midst of World War II and the congress was canceled, not to reconvene until 1949, in Zurich, eleven years after the near split of 1938. In the meantime, soon after the Paris congress the Americans passed what became known as the 1938

rule, asserting full autonomy over training standards in the United States, limiting training to physicians, and barring from admission to the American Psychoanalytic Association all nonphysicians except for a grandfathered handful, all trained before 1938. During the war years the IPA was essentially dormant.

In 1949, when the first postwar congress reconvened in Zurich, a number of divisive issues came to the fore. One was the conditions under which the reconstituted German Psychoanalytic Society could be readmitted, but even more contentious for the IPA was the unresolved issue of relations between the Americans and the Europeans. As IPA president, Jones, together with colleagues from the British Psychoanalytic Society, had taken the lead in exploring this issue even prior to setting a firm date for the congress. Efforts at a solution included an intense transatlantic correspondence and a series of meetings with an American delegation that came to London to meet with the British group. In the end, an amicable gentlemen’s agreement was hammered out, and at the 1949 congress the form of the British-American agreement became clear. The ITC was defunct and would not be resurrected. The American Psychoanalytic Association was granted full control over training standards in the United States with no IPA oversight. The association could thus limit analytic training in American institutes to the medically qualified and bar all nonphysicians from admission to its ranks, except for a few individuals grandfathered under the 1938 rule. In addition, it would have an “exclusive franchise” in its geographic area, meaning that the IPA would recognize no training bodies in the United States other than those affiliated with the American Psychoanalytic Association. Also, from then on, the IPA presidency, heretofore always in Europe and for so long the preserve of Ernest Jones, would alternate between North America and Europe.

In return, the Americans made the concession that direct membership in the IPA could continue, so non-medical analysts who had immigrated to America, though barred from the American Psychoanalytic Association, could still maintain membership in the IPA without being a member of a local affiliated society. All in all, it was an agreement to proceed, in 1949, as if the American proposals of 1938, which never actually came to a vote but which the American Psychoanalytic Association had de facto made operative, had been formally adopted retroactively.

On this basis the IPA, in 1949, reached an accord that formally endured for almost another forty years until the thirty-fifth congress in Montreal in 1987. The issue of lay analysis thus receded from the center of IPA preoccupation until it was abruptly reawakened by a lawsuit against the American Psychoanalytic Association and the IPA, filed in March 1985 in New York and resolved by a negotiated settlement in October 1988, three and a half years later.

For the next several congresses the IPA occupied itself with the codification of its bylaws and procedures. In 1957 President William Gillespie, of London, created a task force headed by Secretary Pearl King to work on codification. After several congresses considered successive drafts, the twenty-third congress in Stockholm, under President Maxwell Gitelson of Chicago, adopted the final document from King's committee. These bylaws codified the special status of the American Psychoanalytic Association as the only regional society of the IPA with the two special privileges of complete autonomy in training matters and exclusive franchise within its geographic area, thus finally rendering *de jure* the rebellious American proclamation of 1938.

Succeeding administrations continued to bring innovations in organizational structure and activity, each marking an increase in IPA administrative authority beyond being merely an organizer of scientific congresses, as it had started out in 1910 and back towards which the Americans tried to consign it in 1938. In 1965, for example, Elizabeth Zetzel, as IPA secretary, was instrumental in launching, in Amsterdam, the first of the still ongoing pre-congress Conferences of Training Analysts. A compromise from the original ITC intention to manage the training activities of the IPA affiliated institutes, the new conferences constituted a forum for representatives of member institutes to discuss training problems encountered worldwide. In 1983 in Madrid the conferences were opened to any training analyst from around the world who wished to participate. Under President Pieter J. Van der Leeuw of Holland (1965–1969), the IPA began disseminating more information and committed itself to helping troubled societies and institutes by dispatching international committees for local site visits, either at the request of the local group or when clear evidence of the need for help became evident. Under President Leo Rangell (1969–1973), the IPA, housed up to that time within the British Psycho-analytical Society from the

days when Ernest Jones was the dominant figure in both organizations, established its own permanent headquarters in London. (The IPA is incorporated, however, under Swiss law.)

President Serge Lebovici of Paris (1973–1977) inaugurated the modern functioning of the IPA. Under his administration the IPA became more international, strengthened its governance, and widened participation in its governance. For example, the 1977 congress was planned for Jerusalem, the first time ever outside of Europe. From then on congresses were hosted in a wide variety of cities on other continents: New York in 1979; Montreal in 1987; Buenos Aires in 1991 (the first time in Latin America); San Francisco in 1995; Santiago, Chile, in 1999; Nice, France, in 2001; and Toronto, Canada, in 2003. Concomitantly, the number of Latin American vice presidents in the IPA Executive Council was increased to give Latin America more representation. Members of the IPA Executive Council began to be more actively involved in administration, the president often asking them to head the ever increasing number of site visits to troubled societies and institutes and to chair regular sponsoring committees for the rapidly proliferating new study groups.

Lebovici also inaugurated two other important moves. The first was to call an all-day meeting of presidents of affiliated societies on the day prior to the opening of each congress. This meeting started as a forum for exchanging information but has since evolved into a structure, the House of Delegates, representing the affiliated societies (as distinct from the Executive Council, elected by the individual members). The House of Delegates was created under President Joseph Sandler of London (1989–1993) and is currently being incorporated into the formal governing structure of the IPA in a manner not yet fully worked out. Lebovici also started a series of IPA symposia that brought together forty to fifty administrative and scientific leaders of the IPA for a week-long conference (with mornings devoted to scientific conferences and afternoons to administrative meetings). These symposia were held every two years, beginning in 1976, in the years between congresses in an isolated rural setting, usually in England but once in Portugal. There were six such symposia before economic retrenchment forced their cancellation during the presidency of Joseph Sandler (1989–1993), and they served to bring the IPA's leadership, scattered all over the world, into close collegial dialogue and friendship.

These symposia also led to the creation of an IPA publishing program. The IPA published monographs on the proceedings of its symposia (held in the years between congresses) and its Conferences of Training Analysts (held in connection with the congresses). These monographs were published in the IPA's four official languages for distribution to members and for sale to others. Two monographs were published commercially, but this plan proved untenable, since it was subject to the schedules of the publishing house and only an English-language publisher was willing to take the commercial risk. The IPA then introduced in-house desktop publishing to publish and distribute a sequence of symposia and Conferences of Training Analysts until it began publishing the *Educational Monograph Series* during the presidency of Robert Wallerstein (1985–1989), which brought this venture to a close.

The presidents after Lebovici—Edward Joseph of New York (1977–1981) and Adam Limentani of London (1981–1985)—built upon the structure put into place by Lebovici. In addition, during these two administrations the IPA involved itself, for the first time, in the turbulent events of the surrounding social and political worlds. This stand forms a stark contrast to the manner in which the IPA, during the many years of Jones's presidency, carefully refrained from political statements, even in the face of Nazi triumphs in Germany and Austria and the subsequent dismemberments of the psychoanalytic societies in Berlin and Vienna. At the thirty-first congress in New York in 1979, this activism took the form of a resolution (in keeping with the practice of other scientific and professional organizations around the world) condemning the repressive practices, disappearances, tortures, and murders being committed under the military dictatorship in Argentina, with a listing of professional colleagues and family members who were among the “disappeared.” At the 1981 congress in Helsinki, faced with a comparable situation in Brazil, the IPA moved the 1983 congress, scheduled for Rio de Janeiro, to Madrid, and shortly later drastically intervened in the analytic society in Rio de Janeiro, where there were serious allegations that a senior figure was shielding a candidate and army psychiatrist complicit in the tortures—a situation that almost totally disrupted all scientific and educational activities in that society. The IPA committee made multiple visits over a several-year period to disentangle the warring factions, marginalize

the extreme protagonists on either side, and enable a central group to restore order and functioning to the society. It should be noted, however, that such strong interventions relating to external political events are rare exceptions and not the norm in the activities of the IPA.

The major event preoccupying the presidency of Robert Wallerstein of San Francisco (1985–1989) was a lawsuit. The issue of lay analysis had not been under consideration by the IPA ever since the agreement for a regional association had given the American Psychoanalytic Association full autonomy over its admissions and training criteria. However, the issue continued as an ongoing controversy within the American Psychoanalytic Association, which, over time, took a number of limited initiatives and appointed a sequence of committees to consider various ways of accommodating the growing pressure to widen its admission criteria beyond psychiatric candidates while trying still to maintain its medical character. U.S. psychologists interested in psychoanalysis were following these years of debate within the American Psychoanalytic Association with growing impatience, and when in 1984 the American Psychoanalytic Association took up the cumulative study of many preceding years to look at the whole problem afresh, the watchful psychologists decided that their only recourse was legal action. Consequently, on March 1, 1985, four clinical psychologists, acting on behalf of a declared class of several thousand, filed a lawsuit against the American Psychoanalytic Association and two of its affiliated institutes on antitrust grounds, alleging a conspiracy in restraint of trade designed to deprive them of access to training and practice in this very prestigious and lucrative means of livelihood.

The IPA was secondarily sued for allowing its American affiliate to engage in these improper activities. The IPA administration headed by Wallerstein (with Edward Weinschel as secretary) was centrally engrossed with this divisive issue from the moment that it took office at the Hamburg congress in the summer of 1985, five months after the lawsuit was filed, until the formal settlement of the suit through a compromise solution promoted by the IPA and accepted by all the involved parties in October 1988, three and a half years after the start of the litigation.

Throughout these often tortuous legal proceedings, the IPA tried to play the role of honest broker between the American Psychoanalytic Association and the

plaintiffs, sympathetically supported by IPA affiliated societies around the world, to whom the exclusionary practices of the American association were completely repugnant. The position of the American Psychoanalytic Association was that it had a right to restrict psychoanalytic training to the medically qualified, a right accorded to it under the regional-association agreement. The American association expected the IPA to support its affiliated organizations in their rights.

Two main events facilitated settlement of the lawsuit. The membership of the American Psychoanalytic Association approved, by more than a two-thirds vote, the recommendation of a new committee studying the question of lay analysis, the Gaskill Committee. This opened the way for qualified nonmedical applicants to be admitted to full clinical psychoanalytic training within its institutes. Soon thereafter the IPA and the American association worked out an alteration of the regional-association agreement (subsequently approved at the IPA business meeting at the 1987 Montreal congress), under which the American association would retain its control over its admission and training standards but would relinquish its exclusive franchise in the United States. This, for the first time, allowed nonmedical psychoanalytic organizations that had unofficially grown up outside the aegis of the American association to qualify for IPA affiliation if they could meet IPA standards. Thus two channels for nonmedical analysts in the United States to become IPA members were opened almost simultaneously, one within the American association and one outside it. All this enabled the IPA and the American Psychoanalytic Association to push successfully for a settlement of the lawsuit, which essentially sought such alterations in training procedures, and bring to final resolution the controversial issue of lay analysis that had so divided the IPA for most of its existence, from the 1925 congress at which the International Training Commission had been established. This long history has been chronicled in Wallerstein (1998).

The Wallerstein administration undertook other important actions: (1) It made Latin America fully equal with Europe and North America by including Latin America in the rotation of the presidency (thus enabling Horacio Etchegoyen to be elected as the first Latin American president of the IPA in 1993) and by equalizing the number of vice presidents at three from each of the three regions. (2) It made IPA governance more democratic by having presidents of affiliated

societies regularly meet with IPA officers at the biannual congresses. (3) It added half-day sessions on child and adolescent analysis, on psychoanalytic research, and on applied analysis as regular components of the scientific program at IPA congresses. (4) It inaugurated the IPA *Educational Monograph Series* (replacing the earlier monographs on symposia and on Conferences of Training Analysts). In this series of teaching monographs, distinguished analysts from around the world discuss a seminal paper of Freud's, reviewing it in the light of intervening developments in analysis since Freud's time. As of 1996, four educational monographs had been published.

President Joseph Sandler of London (1989–1993) and Secretary Jacqueline Amati Mehler took office at the thirty-sixth congress in Rome in 1989. Its four years were marked by three main thrusts: (1) IPA governance became more democratic. For one, the entire worldwide membership began electing IPA officers by mail ballot. This system replaced elections at congress business meetings by those able to be present. In addition, out of the meeting of presidents of affiliated societies there evolved a new structure, the House of Delegates, whose twenty-seven members are elected by and represent affiliated IPA societies. The House of Delegates is gradually working out its role in relation to the president and Executive Council, elected by vote of individual IPA members; (2) The IPA has made psychoanalytic research part of its core mission with the inauguration of an annual Psychoanalytic Research Conference held each year at University College, London; (3) The IPA is making a greater effort to bring precept and practice together in a uniform base of training requirements so that graduating from an IPA institute has comparable meaning and represents comparable accomplishment wherever the institute is located in the world.

At the thirty-eighth congress in Amsterdam in 1993, the first Latin American administration of the IPA was inaugurated, with Horacio Etchegoyen of Buenos Aires as president and Ana Maria Andrade de Azevedo as secretary. This administration has further formalized the role of the House of Delegates (representing the affiliated societies), alongside the president and the Executive Council (representing the individual members), in the governing structure of the IPA. At the fortieth congress in Barcelona in 1997 this administration was succeeded by one from North America headed by Otto Kernberg of New York as president

and Robert Tyson as secretary. From the commitments made during the presidential campaign, it is clear that a major emphasis will be on a marked expansion in IPA support for psychoanalytic research. Kernberg also is committed to increasing regional activities in the IPA as a counterweight to the world gatherings grown increasing unwieldy as the IPA expands in numbers and geographic dispersal. By 2004 it has grown from fewer than 100 close colleagues and mostly friends who started the organization in 1910 to an organization now poised at the 10,000 mark, with over 45 societies in 30 nations on almost every continent and with four official languages. From this base of growing strength and the vitality chronicled in this brief history, it confidently faces its future.

ROBERT S. WALLERSTEIN

### Bibliography

- Freud, Sigmund. (1910). "Wild" psycho-analysis. *SE*, 11: 221.
- Jones, Ernest. (1953–1957). *Sigmund Freud: Life and work*. London: Hogarth.
- Limentani, Adam. (1996). A brief history of the International Psychoanalytical Association. *International Journal of Psycho-Analysis*, 77, 149–158.
- Wallerstein, Robert S. (1998). *Lay analysis: Life inside the controversy*. New Haven, CT: Yale University Press.

## INTERNATIONALE ZEITSCHRIFT FÜR (ÄRZTLICHE) PSYCHOANALYSE

In the wake of conflicts concerning the *Zentralblatt für Psychoanalyse*, the directorate of the International Psychoanalytic Association passed a vote of no confidence in the editor Wilhelm Stekel on November 24, 1912. A new review, the *Internationale Zeitschrift für (ärztliche) Psychoanalyse* (International Review of [Medical] Psychoanalysis), was founded with Hugo Heller, and from 1913 it replaced the *Zentralblatt* as the official organ of the IPA. It was directed by Sigmund Freud with an editorial committee initially consisting of Sándor Ferenczi, Otto Rank, and Ernest Jones.

The creation of this review reflects the efforts of the IPA to define strict limits in relation to other psychoanalytic schools emerging at the time. Its declared aim was first of all to provide structures for scientific

communication, even outside of congresses, between the different associations interested in receiving international psychoanalytic training. Apart from clinical and theoretical contributions, the *Internationale Zeitschrift für (ärztliche) Psychoanalyse* therefore included a considerable number of reviews of contemporary literature as well as an IPA correspondence section bringing together documents concerning the activities of the different groups. It is impossible to overestimate the importance of this review, which brought together on this central stage and around psychoanalysis early scientific discussions involving all the pioneers of the day.

Faced with financial problems toward the end of World War I, Hugo Heller editions could no longer undertake to publish the review and, in 1919, the *Internationaler Psychoanalytischer Verlag* was founded mainly with a view to continuing its publication. In 1919, Karl Abraham and Eduard Hitschmann joined the editorial committee and the term "ärztliche" (medical) was dropped from the title, which thus became *Internationale Zeitschrift für Psychoanalyse*.

In 1920 Otto Rank, as director of the *Internationaler Psychoanalytischer Verlag*, became the chief editor, assisted by the members of the editorial team, who changed from year to year. Following his dispute with Freud, Rank lost all his official functions, including editorship of the review. In 1925 Max Eitingon, Sándor Radó, and Sándor Ferenczi replaced him as the new chief editors.

As soon as World War I came to an end, it became increasingly obvious that psychoanalysis was giving rise to an unexpected and growing interest in the world, particularly in Anglo-Saxon countries, so much so that a central purely German-language publication could no longer meet demands. For this reason Ernest Jones, with the support of Sigmund Freud, founded an English-language counterpart of the *Internationale Zeitschrift für (ärztliche) Psychoanalyse*, the *International Journal of Psycho-Analysis*, which published abstracts and translations of articles in reciprocal collaboration with the *Internationale Zeitschrift für (ärztliche) Psychoanalyse* and *Imago*.

The National Socialist rise to power in Austria in March, 1938, signaled the immediate suspension of the review. United with *Imago*, it appeared under the title *Internationale Zeitschrift für Psychoanalyse und Imago* from 1939 to 1941 during its exile in London.

The German Reich's policy of destruction and the events of the war made it impossible to continue to publish the review in German. The *International Journal of Psycho-Analysis*, published in London and supported by many exiles, then took its place.

LYDIA MARINELLI

See also: Heller, Hugo; *International Journal of Psychoanalysis*, *The*; Internationaler Psychoanalytischer Verlag; *Zentralblatt für Psychoanalyse*.

### Bibliography

Freud, Sigmund. (2003 [1908–1939]). *The Sigmund Freud-Ludwig Binswanger correspondence 1908-1938* (Gerhard Fichtner, Ed. and Arnold J. Pomerans, Trans.). New York: Other Press.

———. (1993 [1908-39]). *The Complete correspondence of Sigmund Freud and Ernest Jones, 1908-1939*, (R.A. Paskauskas, Ed.). London: The Belknap Press of Harvard University Press.

## INTERNATIONALER PSYCHOANALYTISCHER VERLAG

At the end of World War I, it was uncertain whether publisher Hugo Heller could continue publishing the *Internationale Zeitschrift für (ärztliche) Psychoanalyse* and *Imago*. A project was then undertaken to establish a psychoanalytic publishing house independent of commercial interests: International Psychoanalytic Editions.

Creating the company was made possible by the generous support of Anton von Freund, a Budapest businessman and patient of Freud. In the fall of 1918, during the international psychoanalytic congress in Budapest, Freud was made aware of the existence of the grant, intended to promote scientific publication and the publication of professional journals edited by the International Psychoanalytical Association. In January 1919 Otto Rank became head of the company, now named the Internationaler Psychoanalytischer Verlag (International Psychoanalytic Press). Other participants included Sigmund Freud, Anton von Freund, and Sándor Ferenczi. The goal for the publishing company was to ensure the publication not only of journals and other publications with small circulations but above all of an “official reference” (according to Freud’s letter to the presidents of the psychoanalytic

societies, Easter 1932), to stand out from the growing literature on pseudo-psychoanalysis. Subjecting psychoanalytic literature to peer evaluation seemed necessary not only in the German-speaking world but also in the English-speaking world, where Ernest Jones was active.

In 1920 Jones, together with Rank, created an English publishing branch of the Internationaler Psychoanalytischer Verlag, the International Psychoanalytical Press. It published the *International Journal of Psycho-Analysis* and the International Psychoanalytical Library series. Along with English-language authors, this press also published authorized translations of Freud’s work by C. J. M. Hubback and James Strachey.

Working with other publishers, the Internationaler Psychoanalytischer Verlag helped produce books in Hungarian, Polish, and Italian. From its two psychoanalytic journals (*Internationale Zeitschrift für [ärztliche] Psychoanalyse* and *Imago*), the publisher produced books in the following three series: Imago-Bücher and Internationale psychoanalytische Bibliothek (Imago Books and the International Psychoanalytic Library), Neue Arbeiten zur ärztlichen Psychoanalyse (New Research on Medical Psychoanalysis), and Quellenschriften zur seelischen Entwicklung (Basic Writings on Mental Development).

The financial success of the operation was hampered by the runaway inflation after the First World War, which caused von Freund’s grant to lose a considerable portion of its value. From the early 1920s, recurring economic crises were a constant threat to the venture. Finally, in 1923, poor financial circumstances caused the liquidation of the press in Great Britain; personal dissension between Jones and Rank about the future direction of the publishing house was also a factor in its decline.

Conflicts over Rank’s revision of dream theory in his *Das Trauma der Geburt und seine Bedeutung für die Psychoanalyse* (*The Trauma of Birth*), published by Internationaler Psychoanalytischer Verlag in 1924, led to his resignation from the editorial committee. Adolf Josef Storer took over from Rank and carried out a series of ambitious editorial projects: he founded the *Psychoanalytische Bewegung* (Psychoanalytic Movement), launched the *Zeitschrift für psychoanalytische Pädagogik* (Journal of Psychoanalytic Teaching), and began publishing a psychoanalytic almanac.



Unfortunately, the publishers were unable to weather the surrounding economic crisis. After Storer's resignation, Martin Freud took his place in 1932 and attempted, with his father's help, to save the company from bankruptcy. During Easter 1932, Freud wrote an urgent letter of appeal to members of the International Psychoanalytical Association to help save the company. Through the creation of a publishing committee and with donations from members, especially from Marie Bonaparte and Abraham Arden Brill, the company narrowly escaped ruin.

But the economic crisis was replaced by a political crisis following the rise to power of the National Socialists in Germany. Freud's writings were burned in May 1933, and psychoanalytic authors were gradually forbidden to publish in Germany. In 1936 the Leipzig inventory of the *Internationaler Psychoanalytischer Verlag* was seized, and its entire publishing program for Germany had to be canceled. Under these conditions the number of books published and sold declined sharply. Shortly after the beginning of the annexation of Austria into the German Reich in 1938, the Vienna publishing house was seized by the Gestapo and liquidated by an administrator.

LYDIA MARINELLI

*See also: Almanach der Psychoanalyse; Freud, (Jean) Martin; Freund Toszeghy, Anton von; Gesammelte Schriften; Psychoanalytische Bewegung, Die; Rank (Rosenfeld), Otto.*

### **Bibliography**

Hall, Murray G. (1985). *Österreichische Verlagsgeschichte 1918–1938*. Vienna: H. Böhlau.

Sigmund Freud Museum (Ed.). (1995). *Internationaler psychoanalytischer Verlag, 1919–1938*. Vienna: Sigmund Freud Museum.

## **INTERPRETATION**

Interpretation seeks to bring out, within the confines of the analytic method, the latent meaning of a subject's words and behavior; its aim is to reveal unconscious desires and the defensive conflicts that are linked to them. Technically, interpretation consists in making manifest this latent meaning, in accordance with the rules dictated by the various phases of the treatment.

The first version of the theory of interpretation was delineated by Sigmund Freud in his psychoanalytic study of dreams (1900a) and is applicable to other products of the unconscious, such as parapraxes, slips of the tongue, and symptoms. For Freud, psychoanalysis was an art of interpretation, but he preferred the term "construction" as a description of the core of the psychoanalytical method, that is, the unveiling of the unconscious. This "construction" of the unconscious is entirely a matter of applying successive interpretations to the different aspects of a case. The interpretations allow an overall perspective to emerge and thus define a strategy for the treatment; however, it might also be tactically necessary at times to adjust to unforeseen developments.

Interpretation is not just a matter of what needs to be expressed and its actual utterance: it conveys its own meaning, one that disturbs that defensive arrangements meant to maintain the effectiveness of repression. Care must be taken not to provide a premature "translation" of unconscious content, as this risks discouraging the patient, reinforcing his resistance and creating a purely intellectualized understanding. Firstly, the affects associated with these defensive structures need to come to expression, and this implies a struggle of wills. While interpretation is characterized by the necessary intelligibility of its formulations—its reductiveness—as well as by its closeness to manifest representation, generalization, and theorization, it also has a darker and more complex dimension that relates to the polysemy of language, personal symbolism, or the history of the affects involved. Bringing out these affects opens up an economic dimension in which instinctual energy forces the representation into the open. This is made possible, first of all, through the workings of the transference and the counter-transference.

In "The Dynamics of Transference," Freud insisted that interpretation should not begin before the appearance of the transference, and specified that the goal in interpreting the patient's transference is "to compel him to fit these emotional impulses into the nexus of the treatment and of his life-history, to submit them to intellectual consideration and to understand them in the light of their psychical value. This struggle between the doctor and the patient, between intellect and instinctual life, between understanding and seeking to act, is played out almost exclusively in the phenomena of transference. It is on this field that victory must be won" (1912b, p. 108).

What the interpretations communicate to the patient in terms of the construction of the unconscious, and on the basis of the transference, is indissociable from the analyst's reconstruction which is based on the analysis of his own counter-transference. The analyst responds to the transference demands with only a minimum of authority, allowing him to make the counter-transference into a tool for exploring the unconscious of the patient. For Freud, the unconscious of the patient is consequently revealed through the unconscious of the analyst.

The primary goal of interpretation is the lifting of resistance: the cure is not the result of a premature recognition of whatever has been repressed, but occurs through a victory over the resistances at the source of this ignorance. Thanks to the love-transference and the psychoanalyst's patience, the analysand should be able to accept the psychoanalyst's "translation" without these revelations about their unconscious adding to their conflicts or symptoms. Freud rejected any interpretation that is isolated from the symbolic material issuing from the unconscious, and indicated that it would be a mistake to think that the interpretation of dreams is central to all analyses.

As Michel Fain wrote, "While the turning of 1920 [*Beyond the Pleasure Principle*, 1920g] shattered the metapsychology of 1915, conceptions from the first topic continued to influence Freud's conception of interpretation" (1983). It would seem useful to emphasize the necessary complementarity of the two topics, neither being able alone to account for the theoretical role of interpretation.

"The path that starts from the analyst's construction ought to end in the patient's recollection; but it does not always lead so far. . . . If the analysis is carried out correctly, we produce in him an assured conviction of the truth of the construction which achieves the same therapeutic result as a recaptured memory" (Freud, 1937d, pp. 265–66).

Interpretation has recently become one of the latest focuses in the epistemological debate over the status of psychoanalysis. The "experimental" point of view, in which interpretation is conflated with a generalizable scientific truth that results from verifiable protocols and can be duplicated within the context of multidisciplinary research, includes certain models from psychoanalytical theory, comparing them with other developmental models or conceptual tools from psychopathology.

Conversely, the "hermeneutic" point of view results in a purely relative, narrative, and pragmatic conception of truth, whereby the interpretation is only a new version of the life story that makes the patient feel better. Consequently it tends towards a language of action that valorizes the conscious dimension. Highlighting the narrative point of view obviously involves challenging the status of metapsychology (Schafer, Roy, 1983), but the "scientific" point of view ultimately leads to the same tendency.

A closely related notion, often mentioned when clinical cases are being discussed, is that of "intervention." It is often used by default, when the analyst wants to utter words that are deemed appropriate, without the elements of the construction justifying those words being clearly established. It is given that analysts do not merely proffer interpretations during the session—in addition they may request a clarification, verify an element already referred to in the treatment, encourage the patient to continue speaking, and the like.

However, because of the transference situation, it is impossible to predict the outcome of these interventions, whose inoffensive, innocent, or insignificant character cannot be affirmed *a priori*. Jean Cournut has criticized the illegitimacy of this notion, adding that, in his view, "the term 'intervention' should be eradicated from the lexicon of psychoanalysis" (1983).

JACQUES ANGELERGUES

*See also:* Amnesia; Bernfeld, Siegfried; *Construction de l'espace analytique (La-)* (*Constructing the analytical space*); Construction-reconstruction; "Constructions in Analysis"; Dream interpretation; Hermeneutics; Interpretation of dreams (analytical psychology): *Interpretation of Dreams, The*; Over-interpretation; Psychoanalytical treatment; Technique with adults, psychoanalytic; Technique with children, psychoanalytic; Transference; Transference and counter-transference; Translation; *Violence of Interpretation, The: From Pictogram to Statement*.

### **Bibliography**

- Fain, Michel. (1983). Introduction. *Revue Française de Psychanalyse*, 67, 3, 707–716.
- Freud, Sigmund. (1900a). The interpretation of dreams. Part I, *SE*, 4: 1–338; Part II, *SE*, 5: 339–625.
- . (1912b). The dynamics of transference. *SE*, 12: 97–108.

———. (1937d). Constructions in analysis. *SE*, 23: 255–269.

Schafer, Roy. (1983). *The analytic attitude*. London: Hogarth.

### Further Reading

Britton, Ronald, Steiner, John. (1994). Interpretation: Selected fact or overvalues idea?, *International Journal of Psychoanalysis* 75, 1069–1078.

Busch, Fred. (2000). What is a deep interpretation? *Journal of the American Psychoanalytic Association*, 48, 237–254.

Friedman, Lawrence. (2002). What lies beyond interpretation, and is that the right question?, *Psychoanalytic Psychology*, 19, 540–551.

Ogden, Thomas. (1997). Reverie and interpretation. *Psychoanalytic Quarterly*, 66, 567–595.

---

## INTERPRÉTATION

The review *Interprétation* was born in 1967 of a meeting between the desire to challenge the practice and teaching of psychiatric thinking in Canada, on the part of a team of the Research and Teaching Service of the Laurentides Hospital (directed by Marcel Lemieux),—and the passion and commitment of the psychoanalyst who became its editor-in-chief, Julien Bigras.

Having taken from the very beginning the course of interdisciplinarity, for the purpose of furthering reflection through the encounter of the various human sciences, the review, independently of any school, opened itself up equally to literary and artistic milieus, making much room for foreign authors, especially French. Conrad Stein was editor for France between 1967 and 1971. The editorial committee for the first numbers of the review comprised: André Saint-Jean, Claude Lagadec, Pierre Mathieu, Carlo Serlin, Laurent Santerre, Rémi Savard, and Élizabéth Bigras. After a break of seven years, the review began publishing again, with the same editor-in-chief and a new editorial committee, including Jean-Jacques Couvrette, François Peraldi, and Josette Garon.

The review has published many articles on specifically psychoanalytical themes, such as, for example, the psychoanalytic process, fantasy life, and psychoses, or on the question of the training, education, and commitment of psychoanalysts, as well as on the theories and works of Freud and authors who have written about and after him. There have been also a

number of articles relating to anthropology, sociology, literature, pedagogy, semiology, philosophy, theology, and the theory of communication.

This review has published texts of many different forms: clinical and theoretical articles, translations, conferences, and congress reports. Exchanges have taken the form of letters, discussions, and responses; authors have also published original creative works, such as poems, stories, and theatrical scenarios. The review has organized encounters and colloquia, playing an important catalytic role in the Quebec milieu. A crossroads of the human sciences, it has kept open the question of the wealth, but also the limits of interdisciplinarity, as well as that of the limits of psychoanalysis.

JOSETTE GARON

See also: Bigras, Julien Joseph Normand; Canada.

---

## INTERPRETATION OF DREAMS (ANALYTICAL PSYCHOLOGY)

Jung considered the dream a natural and normal psychic phenomenon describing the inner situation of the dreamer, a “spontaneous self-portrayal in symbolical form of the actual situation in the unconscious” (Jung, 1947). In analytical psychology the dream is seen as neither a disguise nor a symptom but as a source of new understanding, especially of the psychic function of archetypal imagery. Jung never distinguished between manifest and latent meaning, since he based his understanding directly on dream content. Analytical psychology does not generally encourage free association per se; rather, it employs circular associations around the various images and actions in the dream to make sense of the dream in its entirety. In analytical psychology, the concepts of sign and symbol have meanings different from their meanings in psychoanalytic usage. For Jung, a sign is a token of meaning that stands for something known, whereas a symbol is an image that points to something partially known but unknowable at its core. A symbol has a subjective dynamic that powerfully attracts the individual and transforms psychological energy.

Jung first read Freud’s *Interpretation of Dreams* in 1900 as a student at the Burgholzi Psychiatric Clinic in Zurich, reviewing it for his fellow psychiatric students

(Jung, 1907). He began to develop his own ideas about the meaning of dreams shortly after his break with Freud around 1912 to 1913, and by 1928 he had outlined his mature views.

Dreams can be interpreted on three levels: objective, subjective, and transference. Any interpretation that refers the images in the dream to the subject's view of external objects is considered an interpretation on the objective level. Any interpretation that refers every part of the dream back to the dreamer is an interpretation on the subjective level. Interpretation on the objective level breaks the dream content down into memory traces referring to the external situation. Interpretation on the subjective level detaches the underlying memories from their external sources and presents the dreamer with the images as inner facts. Such experience of inner reality opens the way for psychological transformation. Transference interpretation is a mixture of the two levels, except that dream images are interpreted in relationship to the transference.

Dreams compensate for attitudes held consciously. This follows from the concept of the psyche as a self-regulating system, dreams representing an unconscious voice. Jung saw compensation as operating in two directions. One he termed the "prospectively function," by which he meant that the dream is an anticipation of future conscious achievement. This does not mean that dreams are prophetic; rather, a dream is a preliminary exercise, a combination of possibilities, roughly sketched out in advance. In their prospective function, dreams can be both integrative and synthetic. In the other direction, the reductive function, the dream operates as a retrospective compensation, bringing up repressed material. A dream can be interpreted in either or both directions at the same or different times and at different developmental stages. No interpretation is considered final.

Another important, uniquely Jungian method in dream interpretation is amplification. Here analogous material is brought into play to enlarge upon the symbols of the dream. Parallels from mythology, folklore, anthropology, comparative religion, ethnology, and current cultural patterns are presented to the analyst to elicit a richer understanding of the dream. Amplification is used less often today, as analytical psychologists have become more aware that it can be used to avoid personal issues.

Basically, analytical psychology teaches an open attitude in interpreting dreams. Jung stressed that each dream should be approached without preconceived notions. At the beginning of the twenty-first century there is a greater emphasis on transference interpretations in analytical psychology. Yet many analytical psychologists hold the view that dream images are part of the objective reality of the psyche and that dream interpretation is central to theory and practice.

THOMAS B. KIRSCH

*See also:* Active imagination (analytical psychology); Amplification (analytical psychology); Analogical interpretation; Analytical psychology; Archetype (analytical psychology); Numinous (analytical psychology); Shadow (analytical psychology).

### **Bibliography**

- Freud, Sigmund. (1900a). The interpretation of dreams. *SE*, 4: 1–338; 5: 339–625.
- Jung, Carl Gustav. (1907). The psychology of Dementia praecox. *Coll. works* (Vol. 3). London, Routledge & Kegan Paul.
- . (1909b). The analysis of dreams. *Coll. works* (Vol. 4). London: Routledge and Kegan Paul.
- . (1928a [1935]). The relations between the ego and the unconscious. *Coll. works* (Vol. 7). London: Routledge and Kegan Paul.
- . (1928b [1948]). On psychic energy. *Coll. works* (Vol. 8). London: Routledge and Kegan Paul.
- . (1928c [1948]). General aspects of dream psychology. *Coll. works* (Vol. 8). London: Routledge and Kegan Paul.
- . (1931–34). The practical use of dream analysis. *Coll. works* (Vol. 16). London: Routledge and Kegan Paul.
- . (1947 [1954]). On the nature of the psyche. *Coll. works* (Vol. 8). London: Routledge and Kegan Paul.

### **Further Reading**

- Edelson, Marshall. (1972). Language and dreams: the interpretation of dreams revisited, *Psychoanalytic Study of the Child*, 27, 203–282.
- Fosshage, James L. (1988). Dream interpretation revisited. *Progress in Self Psychology*, 3, 161–175.
- Rothstein, Arnold (Ed.). (1987). *The interpretation of dreams in clinical work*. Madison, CT: International Universities Press.

## INTERPRETATION OF DREAMS, THE

Even more than the *Studies on Hysteria*, written in collaboration with Josef Breuer (1895d), or the *Project for a Scientific Psychology* (1950c [1895]), *The Interpretation of Dreams* may be considered the founding work of psychoanalysis. It was with this book that Freud sought for the first time to present an overall view of mental functioning. Most of its tenets were maintained unchanged throughout Freud's lifetime, and even today the book is considered indispensable to any possible theoretical progress in psychoanalysis.

Freud became interested in his patients' dreams early in his career, feeling that they might provide useful information about what, consciously or not, they hid from their doctor. He also came to believe that dreams and symptoms were formed in an analogous way. He went further, asserting that the mechanisms involved were not restricted to pathological processes, and that the analysis of dreams could serve as a powerful method for explaining mental functioning in general. He began to write down and analyze his own dreams, and the material generated in this way would eventually constitute the greater part of the empirical evidence on which *The Interpretation* was based.

Preparatory work went on for nearly four years, from the spring of 1896 to the end of 1899. Freud was slowed down in part by a self-imposed obligation to reviewing the whole of the existing literature on dreams, and more importantly by the fact that he had indeed embarked on the development of a general theory of the functioning of the psyche. During a burst of creative energy he produced a first outline in 1895 (the posthumously published "Project for a Scientific Psychology"). He drew inspiration from the theories of his teacher Ernest von Brücke and of Hermann von Helmholtz, who believed that all biological, and hence neurological and by extension psychological, activity could be reduced to physical and chemical processes. On this basis Freud worked out a neurobiological model that was strictly imaginary (albeit filled with extraordinary insights) and entirely based on the supposed working of neurons, which had only recently (1891) been discovered. But he was disappointed with this paper, put it aside, and set about reformulating his theory in terms of mental processes alone. Four years later, in September 1899, the manuscript of *The Interpretation of Dreams* was finished.

The work was published by Deuticke on November 4 of that year, but—prophetically enough for a book that inaugurated the "century of psychoanalysis"—it bore the publication date of 1900. The book had a rather frosty reception, however, and to begin with sales were wretchedly bad. But over the long term it enjoyed an extraordinary success: there were ten reprintings in Germany during Freud's lifetime, and innumerable translations. Over the years Freud continually modified and (especially) added to his text, so that each new edition reflected developments in his thinking.

Freud makes four fundamental claims in *The Interpretation of Dreams*:

1) He proposes a method for investigating mental processes. The content of a dream (its "material") rarely sheds direct light on the processes that shape it; the meaning has to be teased out of the interplay between chains of association in the mind of the dreamer (who is urged to express all thoughts that come to mind, excluding nothing, no matter how irrelevant it may seem) and interpretations offered by the analyst. Through their interaction, these associations and interpretations lead to a clarification of the "latent dream-thoughts" beneath the manifest content. For Freud the interpretation of dreams is the "royal road" to the unconscious—to that part of mental life which has been subjected to repression—in that the manifest content of the dream reveals the "return of the repressed."

2) He lays down a general rule: every dream represents a wish fulfilled. He sets out to show that even when the manifest content of a dream is distressing, the latent meaning always embodies a search for satisfaction. This is a direct echo of the "Project for a Scientific Psychology," according to which the neuronal apparatus tends to release large amounts of energy that circulate within it. In psychic terms, this becomes the "pleasure-unpleasure principle": the reduction of unpleasure and a corresponding access to pleasure by means of a discharge of energy. This account in terms of energy, the basis of the "economic point of view" in Freud's theory, derives directly from Helmholtz and Brücke; its generalization would later lead to the notion of the libido.

3) In order to transform the latent dream-thoughts into manifest content, the dream-work relies on four means of distortion. Freud sees these procedures as belonging to two stages: in the first, the primary processes operate by means of displacement, condensation,

and visual representation; then secondary processes (“secondary revision”) restore a consistency and surface plausibility that makes the dream content acceptable but by the same token guarantees that the dream’s latent meaning is misapprehended.

4) Freud takes pains to emphasize that he is by no means offering a new “dream book”: every dream has an individual meaning discoverable only by applying his principles of interpretation. All the same, the sources of human dreams lie in wishes of a similar kind, and give rise to analogous conflicting forms, while the latent content is submitted to the same transforming mechanisms. The result is the existence of “typical dreams” whose meaning is quasi-universal, even if the details are specific to the individual dreamer. Such typical dreams include dreams of nakedness, dreams of the death of loved ones, examination dreams, and so on.

How is such “common symbolism” related to the individual’s symbolizing processes? This is a question which preoccupied Freud continually, and indeed gave rise to most of the many revisions he made over the years to *The Interpretation of Dreams*.

ROGER PERRON

*See also:* Day’s residues; Dream; Dream’s navel, the; Dream symbolism; Dream work; Fliess, Wilhelm; Freud, Jakob Kolloman (or Keleman or Kallamon); *Freud’s Self-Analysis*; Functional phenomenon; Interpretation; Irma’s injection, dream of; Latent; Latent dream thoughts; Manifest; Primary process/secondary process; Psychic apparatus; Psychic causality; *On Dreams*; Secondary revision; Sleep/wakefulness; Structural theories; Wish-fulfillment.

### Source Citation

Freud, Sigmund. (1900a). *Die Traumdeutung*. Vienna: Deuticke; G.W., 2–3; The interpretation of dreams. *SE*, 4–5.

### Bibliography

Freud, Sigmund, and Breuer, Josef. (1895d). Studies on hysteria. *SE*, 2: 48–106.

Jones, Ernest. (1953–1957). *Sigmund Freud: Life and work*. London: Hogarth Press.

## INTERSUBJECTIVE / INTRASUBJECTIVE

The intersubjective/intrasubjective dichotomy often appears in the psychoanalytic literature against the

background of another pair of opposites, interpersonal/intrapersonal. In reality, these two pairs of opposites cannot be superimposed.

Psychoanalysis is concerned primarily with the intrasubjective and the intrapsychic, and what pertains to the “subjective” (inter- or intra-) presupposes reference to a subject differentiated on both the extrapsychic and intrapsychic levels, whereas that which pertains to the “personal” presupposes only reference to individuals who are differentiated on the extrapsychic level, but may not yet be entirely differentiated on the intrapsychic level.

In his study of early childhood, Donald Winnicott made important contributions to the study of the dynamics of the intersubjective/intrasubjective dichotomy by providing a deeper understanding of the “sense of the continuity of being” and the role of the self-object environment. On the other hand, “developmental” psychoanalysis has focused primarily on the issue of interpersonal relations between the baby and its interactive partners, and has been criticized on a metapsychological level.

The work of Daniel N. Stern, a student of René Spitz, is worthy of mention in that his concept of “affect attunement” seeks to show how a mechanism at the interpersonal level helps open access to the intersubjectivity by which it is in fact determined. Another of Spitz’s students, Robert N. Emde, has also carried out important work in this vein.

Nevertheless, a purely metapsychological approach is problematic here because it is hard completely to disregard a phenomenological point of view. Moreover, the functional mechanisms and modalities that lead from the interpersonal to the intrapsychic are as yet unknown.

BERNARD GOLSE

*See also:* Group psychotherapy; Phallus; Sadosomochism; Symbolization, process of.

### Bibliography

Sameroff, Arnold J., and Emde, Robert N. (Eds.). (1989). *Relationship disturbances in early childhood: A developmental approach*. New York: Basic Books.

Stern, Daniel N. (1985). *The interpersonal world of the infant: A view from psychoanalysis and developmental psychology*. New York: Basic Books.

Squiggle Foundation. (1988). *Winnicott studies. The journal of the Squiggle Foundation. A celebration of the life and work of Marion Milner*. London: Squiggle Foundation.

## **INTRODUCTORY LECTURES ON PSYCHO-ANALYSIS**

The *Introductory Lectures on Psycho-Analysis* is based on a series of two-hour talks given by Sigmund Freud at the University of Vienna between 1915 and 1917 to initiate both doctors and laypeople to the fundamental principles of psychoanalysis. Delivered with the intention of publication at a later date, the published *Introductory Lectures* had enormous success, with fifty thousand copies sold in German during Freud's lifetime. Together with the *Psychopathology of Everyday Life* (1901b), it was—and still is—Freud's best-known work.

The approach Freud used is that of the public lecture. The *Lectures* are not treatises but simplified expositions of ideas and of the results of established research. He provides a number of examples and anecdotes, and devotes a large portion of the book to the psychopathology of everyday life and dreams, subjects of immediate relevance to his audience. Yet he also strives to delineate the special nature of psychoanalysis, particularly the aspects that people find difficult to acknowledge, and that are comparable in their insult to human megalomania as the revelations of Charles Darwin and Nicolas Copernicus.

The book is divided into three parts of unequal length. The first, which is short, is on parapraxis, the second and third, which are more fully developed, are on dreams and the general theory of neuroses. There is a gradual progression in the three sections, accompanied by a notable erasure of the distinction between the normal and the pathological. Freud insists on the versatility of his method, which he claims is easier to understand by the study of dreams rather than of symptoms.

Regarding slips, Freud proposes that their relevance lies in the meaning of the symptom and not the psychophysiological determination. Along with meaning, Freud introduces two of the prime movers of mental life, sexuality and aggressivity. The theory of mental conflict is outlined: parapraxes “arise from the concurrent action of two different intentions” (1916–17a, p. 44). Dreams had been previously discussed in an

abridged presentation addressed to the general public and titled “On Dreams.” (1901a) In this essay, which provides greater details on dreams than the *Introductory Lectures*, Freud makes an attempt to identify and discuss all possible objections to his theory, as he had done in *The Interpretation of Dreams* (1900a). In this regard he discusses the number of interpretations and the complexity of the interpretative process, which he justifies by comparing it to the tortuous efforts of customs agents in trying to find contraband material. He stresses that only practice and experience can determine the actual degree of comprehensibility of the dream and that the “lay public, including the scientific lay public, are well known to enjoy making a parade of scepticism when faced by the difficulties and uncertainties of a scientific achievement” (1916–17a, p. 232).

Part three is extremely condensed, given the scope of the subjects treated, which range from the unconscious to the development of the libido, the formation of various symptoms and how they are handled during psychoanalysis. Freud discusses the differences between his point of view on the libido and that of Carl Gustav Jung. Addressing the notion of the “ego libido,” he tackles the question of treating “narcissistic neuroses,” discusses nosographic considerations in the case of paraphrenia (combining paranoia and precocious dementia under the same term), and ends with the issue of transference. Transference is compared to the intermediate layer between the tree and the bark, a layer that serves as the starting point for the formation of new tissue and an increase in trunk diameter. As a result the patient's symptoms lose their primitive meaning and acquire a new meaning in relation to the transference. The work of healing is then defined as follows by Freud: “The decisive part of the work is achieved by creating in the patient's relation to the doctor—in the ‘transference’—new editions of the old conflicts; in these the patient would like to behave in the same way as he did in the past, while we, by summoning up every available mental force [in the patient], compel him to come to a fresh decision” (1916–17a, p. 454).

In these lectures for the lay public, Freud addressed, as he had done previously in the case of dreams but on a much larger scale, the difficulties and paradoxes of university training in psychoanalysis. “As a result of receiving your instruction at second hand, as it were, you find yourselves under quite unusual conditions

for forming a judgement” (1916–17a, p. 18). Consequently, the claim that there is no objective criterion by which to judge the truth of psychoanalysis appears to eliminate it from the domain of science, where Freud maintains it belongs. The weakness of the epistemological argument leads to the pragmatic argument that we can only learn psychoanalysis through self-experimentation. Here, Freud’s talent as a dialectician is apparent, and in the remainder of the work, he gradually tries to convince his reader of his claims.

SOPHIE DE MIJOLLA-MELLOR

*See also:* Dream; First World War: The effect on the development of psychoanalysis; Neurosis; *New Introductory Lectures on Psycho-Analysis*; Parapraxis; Psychoanalysis; Transference.

### Source Citation

Freud, Sigmund. (1916–1917a [1915–1917]), *Vorlesungen zur Einführung in die Psychoanalyse*, Leipzig-Vienna: Hugo Heller; *GW*, 11; Introductory lectures on psycho-analysis. *SE*, 15–16.

### Bibliography

- Freud, Sigmund. (1900a). The interpretation of dreams. Part 1, *SE*, 4: 1–338; Part 2, *SE*, 5: 339–625.
- . (1901a). On dreams. *SE*, 5: 629–685.
- . (1901b). The psychopathology of everyday life. *SE*, 6.
- Gay, Peter. (1988). *Freud: A life for our time*. London-Melbourne: Dent.
- Strachey, James. (1943–1974). Introductory notes. In *The standard edition of the complete psychological works of Sigmund Freud*. London: Hogarth.

## INTROJECTION

Introjection is a fundamental process in the mental development of the infant, related to incorporation fantasies. Sándor Ferenczi emphasized the idea of identification with the aggressor in post-traumatic syndromes through introjection of the adult’s feelings of guilt.

This notion became fundamental after Ferenczi developed it. In the neurotic it entails including as much of the external world as possible within that individual’s sphere of interests; the neurotic’s ego is pathologically inflated. This mechanism is the opposite

of projection, which causes the paranoiac to project outward emotions that have become too painful; in contrast to the neurotic, the paranoiac suffers from a shrinking of the ego. The schizophrenic, meanwhile, more or less withdraws his or her interest from the outside world. In addition, from the earliest mother-child relations, introjection constitutes a primary process that organizes the psyche, as the very basis of love and thus of the transference.

Introduced by Ferenczi in “Introjection and Transference” (1909), the idea of introjection was taken up by Sigmund Freud in “Instincts and Their Vicissitudes” (1915c), and again in “Mourning and Melancholia” (1916–17 [1915]). It was then further developed by Karl Abraham in the chapter “The Process of Introjection in Melancholia: Two Stages of the Oral Phase of the Libido” in “A Short Study of the Development of the Libido, Viewed in the Light of Mental Disorders,” (1924), devoted to his research on manic-depressive psychosis. In “Instincts and Their Vicissitudes,” with regard to the instinctual mechanisms and love, Freud wrote: “Loving admits not merely of one, but of three opposites. In addition to the antithesis ‘loving—hating’, there is the other one of ‘loving—being loved’; and, in addition to these, loving and hating taken together are the opposite of the condition of unconcern or indifference. The second of these three antitheses, loving—being loved, corresponds exactly to the transformation from activity to passivity and may be traced to an underlying situation in the same way as in the case of the scopophilic instinct. This situation is that of *loving oneself*, which we regard as the characteristic feature of narcissism. . . . (p. 133). . . . [T]he ego-subject is passive in respect of external stimuli but active through its own instincts” (p. 134). The description of turning around of the instinct onto the subject, thus with the same aim but a different object, is supported with the examples of sadomasochism and voyeurism-exhibitionism.

It may be that the severe pathologies of narcissism are organized as a result of these early introjections, producing different unconscious identifications. There are three of these: primary identification, linked to a relation of cannibalistic incorporation (Karl Abraham), a primitive defense mechanism involving absorption of a part of the maternal object; projective identification, whose aim is controlling others by means of projection outside of the self of the good parts that have already been introjected, leading to



impoverishment of the ego and the psychotic consequences that are corollary to the schizoid-paranoid stage (Melanie Klein); and finally, identification with the aggressor, linked to the traumatic origins described by Ferenczi in “Confusion of Tongues between Adults and the Child: The Language of Tenderness and Passion” (1932/1949), where he emphasized the child’s “introjection of the guilt feelings of the adult” (p. 228) when there has been maltreatment or early sexual abuse, whether incestuous or not. He accounted in this way for fragmentation of the personality, turning of the instincts back onto the self (compulsive masturbation and different depressive syndromes) when there has been early abuse of this type (*Verführung* is usually translated as “seduction”). There is also a reversal into their opposites of the child’s instincts after this kind of abuse by an adult, which brings with it the child’s loss of confidence in his or her own perceptions, fragmentation of memories, recurring dreams, and a whole pathological procession that far exceeds the bounds of neurosis (often called “introjection disorder”). It involves emotional disturbance and psychopathic problems, early eating disorders, substance abuse, psychosis, or intergenerational repetition of perverse behaviors.

From a metapsychological perspective that takes into account the idea of adaptation, Ferenczi, at the end of his life, invented a neologism that combined introjection with the violent effects of parental repression and of a certain tendency in analysis. He wrote in his *Journal*: “Child analysis, education, are the ‘intropression’ of the superego by adults” (1985 [1932]). In France, this line of research was continued by Maria Torok and Nicolas Abraham, for example, in “Le crime de l’introjection” (The crime of introjection; 1963), where Abraham evoked the ego’s need, faced with the death, wickedness, or inconstancy of the external object, to put in place “a reintroduction of the corresponding Imago.” Manic-depressive psychosis is triggered not by the loss of the external object, but instead by the threat of losing the indispensable internal object. In each case, what is involved is disavowing the “crime,” which, in the final analysis, is “having introjected the object.”

PIERRE SABOURIN

*See also:* Breast, good/bad object; “Confusion of Tongues Between Adults and the child: The Language of Tenderness and Passion”; Defense mechanisms; Depressive

position; *Ego and the Mechanisms of Defence, The*; Ego ideal/Ideal ego; Identification; Imago; Internal object; “Introjection and Transference”; Melancholic depression; Projective identification; Self-punishment; Superego.

### Bibliography

- Abraham, Karl. (1949). A short study of the development of the libido, viewed in the light of mental disorders. History of the development of the libido.” In *Selected papers on psycho-analysis* (pp. 418–479). London: Hogarth. (Original work published 1924)
- Abraham, Nicolas. (1963). Le crime de l’introjection. In *L’Écorce et le noyau* by Nicolas Abraham and Maria Torok. Paris: Aubier-Flammarion, 1978.
- Ferenczi, Sándor. (1959). Introjection and transference. In *Sex in Psychoanalysis (Contributions to Psychoanalysis)* (pp. 30–80). New York: Dover. (Original work published 1909)
- . (1933 [1932]). Confusion of tongues between adults and the child: The language of tenderness and passion. *International Journal of Psycho-Analysis*, 30, (1949), 225–230. In *Final Contributions to the Problems and Methods of Psycho-Analysis*. London: Hogarth, 1955.
- . (1985). *The clinical diary of Sándor Ferenczi* (Judith Dupont, Ed.; Michael Balint and Nicola Zarday Jackson, Trans.). Cambridge: Harvard University Press. (Original work published 1932)
- Freud, Sigmund. (1915c). Instincts and their vicissitudes. *SE*, 14: 109–140.
- . (1916–1917g [1915]). Mourning and melancholia. *SE*, 14: 237–258.

### Further Reading

- Scharff, Jill S. (1992). *Projective and introjective identification and the use of the therapist’s self*. Northvale, NJ: Jason Aronson.

---

## “INTROJECTION AND TRANSFERENCE”

Sándor Ferenczi met Sigmund Freud in February 1908, and the following year he wrote this successful paper, a theoretical and clinical achievement that proved his creativity and maturity. Previously he had published numerous studies on topics as varied as “love in science,” spiritualism, and the organization of a hospital ward, and had read all the psychoanalytic literature of the time before coming to Vienna. Ferenczi’s practice of hypnosis, psychiatry, and psychoanalysis provided him with a body of material that he used in

this original paper describing the distinction between the mechanism of projection characteristic of psychosis and the introjection characteristic of neurosis. “The neurotic is constantly seeking for objects with whom he can identify himself, to whom he can transfer feelings, whom he can thus draw into his circle of interest, i.e., introject” (p. 40–41), wrote Ferenczi. With regard to psychotics, he distinguished between the “dement,” who “completely detaches his interest from the outer world” (p. 40), and the paranoiac, who “would like to do the same” (p. 40) but who rejects this interest outside of his “ego” and projects his desires into the world. The psychoneurotic suffers from a widening, the paranoiac from a shrinking of his ego” (p. 41).

Some of Ferenczi’s formulations are striking. For example, “The transference born in the unconscious emerges into consciousness with an increased emotional charge, under a reversed sign,” and, later in the article: “The loved objects are introjected, taken into the ego” (p. 65). Observing that transference operates based on minute but meaningful elements, he recalled that in “Jokes and Their Relation to the Unconscious” (1905), Freud had pointed out how in these spontaneous phenomena the representation by means of details acts as a triggering factor for pleasure. “The poetical figure “pars pro toto” is thus quite current in the language of the unconscious” (36).

PIERRE SABOURIN

*See also:* Introjection.

### Source Citation

Ferenczi, Sándor. (1916). Introjection and transference. In his *Contributions to psychoanalysis* (Ernest Jones, Trans.; pp. 30–80.). Boston: Richard G. Badger. (Original work published 1909)

### Bibliography

Freud, Sigmund. (1905c). Jokes and their relation to the unconscious. *SE*, 8: 1–236.

---

## INTROSPECTION

The etymology of the term *introspection* gives a clear indication of its meaning: the mental activity of a subject who is attentive to her/his own psychic processes (who *looks inside*).

Late nineteenth-century psychologists (Alfred Binet in France, the Würzburg school in Germany, Edward Bradford Tiltchener in the United States, to name but a few) considered introspection to be the sovereign method until its throne was usurped by objectivism and behaviorism.

The word has had a bad press in psychoanalysis. However, psychoanalysis was born from just such an effort at self-observation, with Freud’s self-analysis (Anzieu). Unlike introspection, however, which focuses only on conscious processes, that self-analysis opened the way for the “Freudian revolution” (Robert): Freud’s discovery, below the conscious level, of wishes and the obstacles in their way, of the roundabout processes such wishes use to achieve fulfillment—in a word, the unconscious.

Introspection should be clearly distinguished from the “capacity for insight,” the patient’s ability in the course of treatment to experience his or her own psychic dynamics in a new way—a major feature of the psychoanalytic approach (Blacker).

ROGER PERRON

*See also:* Autobiography; Insight; Sartre and psychoanalysis; Self-consciousness.

### Bibliography

Anzieu, Didier. (1986). *Freud’s self-analysis* (Peter Graham, Trans.). London: Hogarth and the Institute of Psychoanalysis. (Original work published 1975)

Blacker, Kay Hill. (1981). Insight (panel). *Journal of the American Psychoanalytic Association*, 29, 659–672.

Robert, Marthe. (1964). *La Révolution freudienne*. Paris: Payot.

---

## INTROVERSION. *See* Extroversion/introversion

---

## INVARIANT

In the first chapter of his book *Transformations: Change from Learning to Growth* (1965), Wilfred Bion defined the idea of the invariant and elucidated the link between transformations and the invariant. He used the metaphor of a painter, a painting, and a field

of poppies to explain that the patient and the analyst have to “repaint” new realizations, starting from the primal scene, onto the canvas of the transference. In this process, a constant must be recognized for meaning to emerge. What remains unchanged between the real field of poppies and the field of poppies on the painter’s canvas, that is, between the primal scene and a transference realization, constitutes the invariant.

To develop further his ideas on the invariant, Bion turned to the notion of mathematical invariance. By way of illustration, Bion explained that the mathematical use of symbols such as ellipses, circles, dots, and lines, no matter how coherent such a use may be, must not cause us to forget that this does not involve “things in themselves,” and that a change in vertex can change the data. Thus, the eye sees two parallel lines as converging at a point that, for the mathematician, does not exist. While in algebraic projective geometry, invariance makes it possible for there to be an object common to a circular object and the elliptical representation of it, this does not apply in the case of lengths, angles, and congruence, even though these data are also a part of Euclidean geometry. Why should not the same be true of psychoanalysis? What are the invariants specific to it? How are they related to one another? According to Bion, psychoanalysis involves transformations. Through interpretations, which are themselves transformations, the analyst gains access to the analysand’s original experience and its realization.

In the work of interpretation, theories are like the painter’s tools, and they give access to meaning only if they have invariants. These theories vary in different methods of interpretation, so that a Kleinian transformation is different from a classically Freudian one. The meaning transmitted by the theory is also different, even if the material transformed is the same in the two cases. To illustrate his thinking, Bion offered a clinical example: In a first stage, the analysis seemed to reveal a patient suffering from hypochondriacal pain, but then in the second stage, external events (a family crisis, hospitalization) disrupted the mechanism and put the treatment at risk. What had changed? What had remained unchanged, invariant? In Bion’s view, the analyst must think in terms of the fate of the external and internal objects. What appeared during the second stage as external emotional objects (worried relatives, the hospital) corresponded to what remained contained, in the form of internal objects, in pains in the knee, leg, or abdomen.

What the analyst considered internal transformed into something external, but the emotional element, though disguised, had remained unchanged. Thus, the invariant provides a link that goes beyond an apparent disconnect. It ensures the continuity necessary for psychic growth and gives the interpretation its effectiveness.

JEAN-CLAUDE GUILLAUME

See also: Transformations.

### **Bibliography**

Bion, Wilfred R. (1965). *Transformations: Change from learning to growth*. London: Heinemann.

---

## **INVESTMENT.** See *Cathexis*

---

## **IRMA’S INJECTION, DREAM OF**

Freud’s dream of “Irma’s injection” introduced the process of dream interpretation and, in a way, psychoanalytic technique as well. It is described in the second chapter of *The Interpretation of Dreams*, “The Method of Interpreting Dreams,” and was reinterpreted many times by Freud’s successors and biographers.

Early in the morning of July 24, 1895, Freud, then on vacation at the Hôtel Bellevue, near Vienna, had a dream about one of his patients, whom he called Irma. The manifest content of the dream can be summarized as follows:

Irma is not doing well; she has pain in her throat, stomach, and nose. Freud examines her in spite of her reluctance and is disturbed, wondering if he has made a medical error. He calls over his two friends M. and Otto, both doctors, for a consultation. This results in an absurd diagnosis that involves trimethylamine.

Later in *The Interpretation of Dreams*, Freud provided a detailed account of this dream that illustrated his approach to dream analysis. The analytical procedure suggested by Freud begins by examining “day residues,” events that occur during the days preceding the dream and which, through association, can clarify the dream episode and restore the identity of the protagonists. The interpretation is guided by the

assumption that the dream is the fulfillment of a wish, in this case, the wish to deflect responsibility for the fault onto someone else, namely M. and Otto. Freud's friend Wilhelm Fliess, an otorhinolaryngologist, who played an important part in Freud's self-analysis, appeared in the background of the dream in connection with the anomalous appearance of turbinate nasal bones in Irma's throat. In reality, Fliess had previously made a serious professional error in treating one of Freud's patients, Emma Eckstein, leaving a bandage in one of her nasal cavities after an operation, which had resulted in infection and serious hemorrhaging.

The interpretation of this dream was the beginning of Freud's self-analysis, which he conducted primarily through analysis of his own dreams. He chronicled the results of this process in *The Interpretation of Dreams* and thus introduced the practice of psychoanalysis itself.

ROGER PERRON

See also: Eckstein, Emma; *Interpretation of Dreams*, The; Mathilde, case of; Real, the (Lacan); Rie, Oskar; Wish-fulfillment

### Bibliography

- Anzieu, Didier. (1986). *Freud's self-analysis* (Peter Graham, Trans.). London: Hogarth and the Institute of Psychoanalysis. (Original work published 1975).
- Freud, Sigmund. (1900a). The interpretation of dreams. *SE*, 4–5.
- Jones, Ernest. (1957). *Sigmund Freud: Life and work*. London: Hogarth.
- Schur, Max. (1966). Some additional "day residues" of "the specimen dream of psychoanalysis." In R. M. Loewenstein, L. M. Newman, M. Schur, and A. J. Solnit (Eds.), *Psychoanalysis: a general psychology*. New York: International Universities Press.

## ISAACS-SUTHERLAND, SUSAN (1885–1948)

A British psychoanalyst and member of the British Psycho-Analytical Society, Susan Isaacs was born in Bolton, Lancashire on March 24 1885, and died on October 12, 1948 in London.

Isaacs came from a middle-class English family from the Midlands. She was educated at Bolton secondary

schools and then at Manchester and Cambridge Universities. She taught at Darlington Training College in 1913–14 and then was appointed lecturer in logic at Manchester University in 1914–15. During the First World War she was appointed tutor in Psychology at London University where she taught until 1933. She was analyzed by Flügel and then from 1922 by J. Riviere. She became an associate member of the British Psycho-Analytical Society in 1921, and a full member in 1923. She was a member of the Training Committee in 1944–45.

Isaacs's contributions to psychoanalysis were particularly important in the field of education. As early as the twenties, from 1923–1927, with the help of her husband, she directed the famous Malting House School project at Cambridge to conduct the education of a small group of children aged two to seven as a piece of scientific work and research. The theoretical framework of the project was deeply influenced by Melanie Klein's views on the importance of phantasy and play in young children. The results of this research, condensed in two volumes, *Intellectual Growth in Young Children* (1930) and *Social Development of Young Children* (1933), were immediately acknowledged as a new way of looking at the development of children and influenced even Jean Piaget.

Between 1929 and 1936, under the name of Ursula Wise, she replied to parents' questions concerning their children in *Nursery World*. She thereby exerted significant influence Britain using the psychoanalytic ideas derived mainly from Melanie Klein in changing patterns of education of generations of children in Great Britain. She effectively founded the Department of Child Development at London University in 1933. During the war she directed the Cambridge Evacuation Project; see the *Cambridge Evacuation Survey* (1941).

Isaacs's theoretical contributions played a fundamental role during the Controversial Discussions between Anna Freud and Melanie Klein (1941–45). Due to her clear theoretical mind and her academic background in general psychology, logic, and education. Klein chose her to write, read and discuss the first paper of the Discussions, "The Nature and Function of Phantasy" (1943), which, in an abridged version, was published in 1948. In this paper, which is her main theoretical contribution to psychoanalysis, Isaacs very clearly expressed Klein's views on the importance that unconscious phantasies play in the development of the

child from the beginning of its life and tried to support Klein's views, linking them where possible to general academic psychology and epistemology.

Her other clinical and theoretical contributions were collected and reprinted in a book entitled *Childhood and After* (1948).

RICCARDO STEINER

*See also:* British Psycho-Analytical Society; Controversial Discussions; Fantasy; Great Britain; Imago; Unconscious fantasy.

### **Bibliography**

- Gardner, Dorothy E. M. (1969). *Susan Isaacs*. London: Methuen Education.
- Isaacs, Susan. (1930). *Intellectual growth in young children*. London: Routledge.
- . (1933). *Social development in young children*. London: Routledge.
- King, Pearl H.M., and Steiner, Riccardo. (1991). *The Freud-Klein controversies 1941–1945*. London and New York: Tavistock Publications-Routledge, New Library of Psychoanalysis.
- Rickman, John. (1950). Obituary. Susan Sutherland Isaacs C.B.E. M. MA. D. Sc. (Vict), Hon. D. Sc. (Adelaide). *International Journal of Psycho-Analysis*, 31, 279–285.

---

## **ISAKOWER, OTTO (1899–1972)**

American physician, psychiatrist, and psychoanalyst, Otto Isakower was born in Vienna on June 2, 1899, and died in New York on May 10, 1972.

He studied medicine, graduating in 1923, and remained at the University of Vienna to specialize in psychiatry, working with Paul Schilder and Heinz Hartmann in Julius Wagner-Jauregg's psychiatric clinic. After analysis with Paul Federn, he became a member of the Vienna Psychoanalytic Society (WPV) in 1925, and later served as a training analyst. From 1934, he served as co-chairman with Eduard Hitschmann at the ambulatorium of the Vienna Psychoanalytic Institute. A Jew, he was forced to flee upon the arrival of the Nazis in 1938.

Isakower first emigrated to London where in June 1938 he married Salomea Gutmann, also a physician and, from 1928, a member of the WPV. They joined the British Psycho-Analytical Society and worked in

Liverpool and Manchester, and Isakower was selected to co-edit the collected edition of Freud's works (*Gesammelte Werke*) that Anna Freud carried on from London. In 1940, the couple emigrated to New York where they would spend the rest of their lives. A member of the New York Psychoanalytic Society, Isakower became essentially involved in teaching at its Institute. He served as chairman of the Educational Committee and for many years was chairman of the Curriculum and Library Committees. In February 1972, he gave up his teaching activities at the Institute due to a cardiac ailment. He died three months later.

A man of considerable learning, fascinated by history, he left only a few scientific contributions. Most notable was his classic description of self-observed hypnogogic states and body-ego regression while falling asleep, which came to known as the "Isakower phenomena." First published in German in 1936, his "Beitrag zur Pathopsychologie der Einschlafphänomene" appeared two years later in English as "A Contribution to the Pathopsychology of Phenomena Associated with Falling Asleep" (Isakower, 1938). In addition, through his teaching of the techniques of interpretation of dreams, he influenced several generations of New York psychoanalysts.

ALAIN DE MIJOLLA

*See also:* *Gesammelte Werke*; Isakower phenomenon; Lehrinstitut der Wiener psychoanalytischen Vereinigung; New York Psychoanalytic Institute.

### **Bibliography**

- Isakower, Otto. (1938). A contribution of the pathopsychology of phenomena associated with falling asleep. *International Journal of Psycho-Analysis*, 19, 331–325.
- Kronold, Edward. (1973). Otto Isakower (1899–1972). *International Journal of Psycho-Analysis*, 54, 369.
- Mühlleitner, Elke. *Biographisches Lexikon der Psychoanalyse (Die Mitglieder der Psychologischen Mittwoch-Gesellschaft und der Wiener Psychoanalytischen Vereinigung 1902–1938)*. Tübingen: Diskord, 1992.

---

## **ISAKOWER PHENOMENON**

In 1936 Otto Isakower published an article on the psychopathology of phenomena associated with falling asleep: "Beitrag zur Pathopsychologie der Einschlafphänomene" (A contribution to the psychopathology of

phenomena associated with falling asleep). It dealt with a varied set of phenomena similar to certain hypnagogic states and capable of being observed “in a number of patients suffering from widely different types of psychological disorders and also in some normal persons” (p. 331).

After studying several clinical cases, Isakower observed:

Most striking of all is the blurring of the distinction between quite different regions of the body, e.g. between mouth and skin, and also between what is internal and what is external, the body and the outside world. We note too the amorphous character of the impressions conveyed by the sense-organs. The visual impression is that of something shadowy and indefinite, generally felt to be ‘round’, which comes nearer and nearer, swells to a gigantic size and threatens to crush the subject. It then gradually becomes smaller and shrinks up to nothing [...] The auditory impression is of a humming, rustling, babbling, murmuring, or of an unintelligible monotonous speech. The tactile sensation is of something crumpled, jagged, sandy or dry, and is experienced in the mouth and at the same time on the skin of the whole body. Or else the subject feels enveloped by it or knows that it is close at hand. Sometimes it feels as if there were a soft yielding mass in his mouth, but at the same time he knows that it is outside him (p. 333).

The reference to the breast is obvious but the description is polymorphous. It appeals to the different senses, it is based on a relative confusion of the boundaries between the outside and the inside. It implies difficulty in evaluating distances; the mouth is often the center of these phenomena, that are sometimes played out in an atmosphere of *déjà vu* and against a background attitude of self-observation in the subject.

Over and above all the neurophysiological factors that are implied in these sort of phenomena, Isakower attempts to conduct a metapsychological analysis that refers back to a set of experiences that were lived through at a very early age, that may be at the origin of the somewhat unexpected success of this description: regression, splitting of the ego, relative indifferentiation of affects—all elements that led the author to conclude “we can observe the regressive revival of ego-attitudes which from the ontogenetic standpoint are primitive” (p. 345).

Such is the Isakower phenomenon, as it opens a window on the very ancient sensory history of the child, particularly the child at the breast if not, indeed, in the uterus. Hence the conclusion of the article: “In dreams and in the phenomenon which is the subject of this paper we have the best authenticated instances of the way in which that function may be renounced in order to conjure up lost objects and submerged worlds” (p. 345). In his own way and in a literary context, Marcel Proust described somewhat comparable phenomena on the verge of sleep.

BERNARD GOLSE

*See also:* Dream screen; Isakower, Otto.

### **Bibliography**

Isakower, Otto. (1938). A contribution to the psychopathology of phenomena associated with falling asleep. *International Journal of Psycho-Analysis*, 19, 331–345. (Original work published 1936)

---

## **ISOLATION**

“Isolation” is the defense mechanism characteristic of obsessional neurosis. The links of a thought, idea, impression, or feeling with other thoughts or behaviors are broken by means of pauses, rituals, magical formulas, or other such devices.

In “The Neuro-Psychoses of Defense,” Freud conceived of defense, in hysteria as well as in phobias and obsessions, as a form of isolation: “defense against the incompatible idea [is] effected by separating it from its affect; the idea itself [remains] in consciousness, even though weakened and isolated” (1894a, p. 58).

In the case of the “Rat Man,” Freud wrote suggestively of “isolation” though still without naming it as a specific neurotic defense mechanism. He wrote that, in contradistinction to hysteria, in which amnesia attests to a successful repression, obsessional neurosis reveals that “[t]he infantile preconditions of the neurosis may be overtaken by amnesia, though this is often an incomplete one. . . . The trauma, instead of being forgotten, is deprived of its affective cathexis; so that what remains in consciousness is nothing but its ideational content, which is perfectly colourless and is judged to be unimportant” (Freud 1909d, pp. 105–106). Thus, in obsessional neurosis, “patients will

endeavour to ‘isolate’ all such protective acts from other things” (p. 243).

In *Inhibitions, Symptoms and Anxiety* (1926d), Freud returned to the analysis of isolation as a defense mechanism in obsessional neurosis—a view that Anna Freud would further develop in 1936—and he emphasized how isolation involves the “the taboo on touching” to the extent that it involves “removing the possibility of contact; it is a method of withdrawing a thing from being touched in any way. And when a neurotic isolates an impression or an activity by interpolating an interval, he is letting it be understood symbolically that he will not allow his thoughts about that impression or activity to come into associative contact with other thoughts” (pp. 121–122).

ELSA SCHMID-KITSIKIS

*See also:* Defense mechanisms; *Ego and the Mechanisms of Defence, The; Inhibitions, Symptoms and Anxiety*; Neurotic defenses; Obsessional neurosis.

### **Bibliography**

- Freud, Anna. (1966). *The ego and the mechanisms of defence*. New York: International Universities Press.
- Freud, Sigmund. (1894a). The neuro-psychoses of defence. *SE* 3: 41–61.
- . (1909d). Notes upon a case of obsessional neurosis. *SE* 10: 151–318.
- . (1926d). Inhibitions, symptoms and anxiety. *SE* 20: 75–172.

## **ISRAEL**

Reflecting the intense struggle of generations not only for survival but also for the establishment of a new social order, Israeli psychoanalysis is intertwined with modern Israeli history, the reestablishment of a nation. After the publication of the 1917 Balfur Declaration, which provided the basis for establishing a Jewish state in Palestine, the British Zionist Commission was appointed. Among its members was David Eder, the first secretary of the British Psychoanalytical Society, founded in 1913. He stayed in Palestine from 1918 to 1922, during which time he urged cooperation between Jews and Arabs and proposed extending medical and social services to all segments of the population. Together with A. Feigenbaum, who immigrated

to Palestine from Vienna in 1920, he worked with teachers and educators, applying psychoanalytic theories.

After both had left Palestine, there was little or no active psychoanalytical work in Palestine until the arrival of Max Eitingon (1881–1943) in Jerusalem in 1933, following Hitler’s rise to power. He proceeded to found the Palestine Psychoanalytic Society (later the Israeli Psychoanalytic Society) with the help of other refugees who, like himself, came to Palestine via Berlin (Moshe Wulff, Ilja Schalit, Anna Smelianski, Gershon and Gerda Barag, Vicky Ben-Tal, Ruth Jaffe, and others).

Eitingon hoped to set up the first chair of psychoanalysis at the Hebrew University in Jerusalem, where Freud had been a member of the first board of governors. But the university authorities considered the inclusion of psychoanalysis in the university setting to be premature, as a chair of psychology had yet to be established. On December 5, 1933, Freud wrote to Judah Magnes, the rector of the university, “The plan to establish a chair for psychology indicates a barely disguised rejection of psychoanalysis and the University of Jerusalem would thus have followed the example of other official teaching institutions. It is then comforting to bear in mind that Dr. Eitingon is determined to pursue the practice of psychoanalysis in Palestine also independently of the University.” Nonetheless, the attempt to introduce psychoanalysis into the university was a historic first.

Eitingon then decided to create an independent psychoanalytic institute modeled after the Berlin institute. In 1934 he founded a polyclinic and the Palestine Institute of Psychoanalysis, which became the eleventh member institute of the International Psychoanalytical Association. As in Berlin, the purpose was to offer treatment, training and supervision, and a forum for discussing psychoanalytic theory. The Israeli clinic still functions according to this model to the present (2004).

Eitingon served as president of the Israeli Psychoanalytic Society (Hachevra Hapsychoanalytit be Israel) during its first ten years. The formative years of the society and the institute were characterized by idealism, devotion, and hard work, often overshadowed by political and economic difficulties. Eitingon’s spirit continued to prevail after him, and within a few years there were twenty analysts practicing in Palestine. Three groups were formed in the three major cities,

and all three participated in the institute. Eitingon's concern and compassion for those who needed psychoanalytic treatment was maintained and handed down from one generation of analysts to the next (the first pioneer group even raised a small fund called the "Institute's Loan Fund" to offer needy patients a daily meal, as an empty stomach is not conducive to analysis). It should be noted that in the first ten years the language used at meetings was German, and for a while later as well, some analyses were carried out in a language in which either the analyst, the patient, or both were not fluent, and they sometimes even used different languages. Eitingon left a legacy of interdisciplinary and multicultural relations and interests that made the institute a vibrant intellectual and cultural center.

The second president of the Israeli Psychoanalytic Society was Moshe Wulff (1943–1953). Wulff was born in 1878 in Odessa, Russia, and later settled in Tel Aviv. He made many important contributions to psychoanalysis, one of them being "Fetishism and Object Choice in Early Childhood" (1946). On the basis of his findings, Wulff formulated a theory about the transition from infantile narcissism to the first genuine libidinal cathexis of an outside object. He also promoted the acceptance of analysis in Israel, especially in educational circles. After Wulff, the presidency of the society rotated for almost twenty years between Heinz Winnik, founder of the *Israel Annals of Psychiatry and Related Sciences* and a pioneer of psychiatric education in Israel, and Erich Gumbel, the first graduate of the institute.

In the 1950s Israeli analysts became increasingly involved in education and training. Heinz Winnik and Ruth Jaffe were the first psychoanalysts to head psychiatric hospitals. Erich Gumbel led an effort that began a three-year program in psychotherapy for non-analysts, and it still continues in 2004. Analysts began teaching at the School of Medicine in Jerusalem.

In the 1960s New Yorker Mortimer Ostow set up a group in the United States of corresponding members of the Israeli Psychoanalytic Society. These American analysts maintained a special relationship with the Israeli society through visits, symposiums, and financial assistance.

Almost as a rule, members of the Israeli Psychoanalytic Society have been continuously involved in social issues. A topic of special interest to analysts is the special conditions under which children were raised in

kibbutzim. Shmuel Golan, a leading theoretician and practitioner in the kibbutzim, based his educational and developmental theories on psychoanalysis (1959). Shmuel Nagler, another psychoanalyst involved in work with kibbutzim, wrote of his clinical observations of kibbutz children (1963).

In the Six-Day War (1967), Yom-Kippur War (1973), Lebanon War (1982), and Gulf War (1991), psychoanalysts assumed a significant role in treating and researching combat-stress reactions and the consequences of social violence (Raphael Moses, Gad Tadmor). Other societal issues of great interest to Israeli analysts were the Israeli-Arab conflict, immigration, and survivors of the Holocaust and their children (Hillel Klein, Shamai Davidson, Raphael Moses, Dan Hertz, Ilani Kogan, Shalom Robinson, Martin Wanhg, and Yolanda Gampel). The Israeli Psychoanalytic Society and the Freud Center cosponsored conferences and dialogues between Israeli and German analysts. Prominent in this dialogue was Hillel Klein, a survivor of Auschwitz. This dialogue has evolved into a working conference held under the title "Germans and Israelis: The Past and the Present."

In 1977 the International Psychoanalytical Association held its thirtieth congress in Jerusalem. This was the first IPA congress held outside Europe. At this time, after efforts by numerous analysts throughout the world, among them Martin Wanhg, Hebrew University established a chair of psychoanalysis, thus realizing Freud's dream. Joseph Sandler was the first person to hold this chair. He stayed in Jerusalem with Anne-Marie Sandler, his wife, and contributed greatly to the further development of psychoanalysis in Israel. After Sandler, a number of distinguished psychoanalysts were appointed to this chair, including Albert Solnit, who developed psychoanalytical thought in the Ben Gurion University Medical School. In the 1990s the chair was held by Shmuel Erlich, a senior psychoanalyst and academician.

Over the past twenty years, among those who made major theoretical and clinical contributions to psychoanalysis through the Israeli Psychoanalytic Society were Pinchas Noy (who contributed to psychoanalysis in the fields of art and creativity), Rivka Eiferman, Rina Moses-Hrushevski, Emanuel Berman, Ruth Stein, and Shmuel Erlich. Those who contributed to the development of child analysis in Israel include Naomi Weiss, Eliezer Ilan (who was the director of the child guidance clinic in Jerusalem), Yechezkiel Cohen



(who directed a residential treatment center where boys receive psychoanalytic treatment and education), Raanan Kulka, and Yolanda Gampel.

A theme that Israeli psychoanalysts are very involved with is the consequences of social violence. *Psychoanalysis at the political border* (Rangell and Moses-Hrushovski, 1996), presents, among other topics, the contributions of Israeli psychoanalysts to compelling issues confronting groups and nations.

In 2004 the Israeli Psychoanalytic Society has more than 100 members, and the Israeli Psychoanalytic Institute, as it is now called, has more than 70 candidates. The number of applicants has been five times higher than can be accepted. Throughout the years, analysts who completed their training in different institutes have immigrated from Argentina, France, Holland, and the United States, bringing different outlooks and perspectives from a variety of paradigms in psychoanalysis. If influence initially emanated from European, especially classical Freudian Berliner and Viennese, psychoanalysts, current major influences are Melanie Klein's model and Heinz Kohut's ideas. During the mid-1990s Donald Winnicott's and Wilfred Bion's concepts have achieved prominence in teaching and discussion in the society. The society and institute are growing and developing creatively; its members hold leading positions in psychiatry, psychology, and particularly academia.

YOLANDA GAMPSEL

### Bibliography

- Cohen, Yecheskiel. (1988). The "golden fantasy" and countertransference: Residential treatment of the abused child. *Psychoanalytic Study of the Child*, 43, 337–350.
- Golan, Shmuel. (1959). Collective education in the kibbutz. *Psychiatry*, 22, 167–177.
- Kulka, Raanan. (1988). Narcissism and neurosis—an opportunity for integration in psychoanalytic theory and technique. *International Journal of Psycho-analysis*, 69, 521–531.
- Moses, Raphael. (1998). Psychoanalyse in Israel. *Psychoanalytische Blätter*, 9.
- Moses-Hrushovski, Rina. (1994). *Deployment: Hiding behind power struggles as a character defense*. Northvale, NJ: Jason Aronson.
- Noy, Pinhas. (1973). Symbolism and mental representation. *Annual of Psychoanalysis*, 1, 125–158.
- Rangell, Leo, and Moses-Hrushovski, Rena (Eds.). (1996). *Psychoanalysis at the political border*. Madison, CT: International Universities Press.
- Wulff, Moshe. (1946). Fetishism and object choice in early childhood. *Psychoanalytic Quarterly*, 15, 450–471.

---

## ITALY

On June 7, 1925, Professor Marco Levi Bianchini (1875–1961), director of the psychiatric hospital of Nocera Inferiore (Salerno), helped create the Societa Psicoanalitica Italiana (SPI) (Italian Psychoanalytic Society). Of its members only Dr. Edoardo Weiss (1899–1970) had been analyzed. This was an important cultural event given the climate of indifference toward psychoanalysis in the world of Italian neuropsychiatry, then dominated by Enrico Morselli (1852–1929).

In 1915, there appeared the first work of Freud translated into Italian and published by Marco Levi Bianchini for the Biblioteca Psichiatrica Internazionale under the title *Sulla psicoanalisi* (On Psychoanalysis); it included the five lectures given by Freud at Clark University in the United States. The review *Archivio Generale di Neurologia, Psichiatria e Psicoanalisi*, founded in 1920 by Levi Bianchini, became the official organ of the SPI in 1925.

On October 1, 1932, Edoardo Weiss transferred the SPI from Trieste to Rome, and Levi Bianchini became honorary president. Weiss, a Jewish physician from Trieste, had known Freud in Vienna when he was still a student and had been sent to Paul Federn for his personal analysis. He completed his training as an analyst in 1913 before obtaining, the following year, his medical diploma. After returning to Trieste he began to practice as a psychoanalyst (1919). The core of the new society consisted of Cesare Musatti (1897–1989), Nicola Perrotti (1897–1970), and Emilio Servadio (1904–1995), the last two being students of Edoardo Weiss.

Other new publications appeared, including the ephemeral *Rivista di Psicoanalisi* in 1932, which was banned by the Fascist government at the end of 1933. In 1931, Weiss's *Elementi di Psicoanalisi* was published, with a preface by Sigmund Freud. The book made an important contribution to the understanding of psychoanalysis, and in fact was the first true work of psychoanalysis published in Italy (in 1937 it was in its third edition).

But the cultural climate in Italy under Fascism was not conducive to the spread of psychoanalysis. To this must be added the hostility of official psychology, represented by the Catholic Agostino Gemelli (1878–1959, see especially the articles published between 1924 and 1925 in *Civiltà cattolica*), and mainstream philosophy, which was influenced by Benedetto Croce and Giovanni Gentile. An opportunity arose, however, through the indirect contact between Freud and Benito Mussolini. The father of a patient of Edoardo Weiss, Giovacchino Forzano, was a friend of the Fascist dictator. During a consultation in Freud's office, in the presence of Edoardo Weiss, he asked Freud to dedicate one of his books to Mussolini. Weiss was extremely embarrassed but Freud accepted with a certain ironical detachment and wrote the following dedication in the volume selected (*Warum Krieg?, Why War?*): "To Benito Mussolini, with respectful greetings from an old man who recognizes in you the hero of a culture. Vienna, April 26, 1933." Later (1952) Weiss felt obligated to explain Freud's behavior to Kurt Eissler, secretary of the Freud Archives in New York, insisting on his rejection of fascism. In a letter of June 30, 1956, to Ernest Jones, he attempted to contest the statement of his patient, the daughter of Giovacchino Forzano, according to whom Mussolini intervened with the Viennese authorities to ensure Freud's safety and enable the family to leave Vienna.

Notwithstanding Weiss's difficulties as the head of the Italian delegation, he was able to participate in the international congresses of the International Psychoanalytic Association (IPA) in Wiesbaden (1932), Lucerne (1934), and Marienbad (1936). In 1935 the IPA recognized the SPI as a member society, but the Fascist government looked askance at the affiliation of Italian psychoanalysts with a foreign association. Emilio Servadio was refused the necessary authorization from the Ministry of Foreign Affairs to affiliate with the Vienna Psychoanalytic Society and the IPA. In a report dated April 20, 1935, Carmine Senise, chief inspector of police, described the Vienna Psychoanalytic Society as a subversive movement of leftist Jews and claimed that Freud maintained relations with extremists and with Italian anarchists. This climate of hostility did not prevent Italian analysts from publishing in 1936, in the *Biblioteca Psicoanalitica Internazionale*, a series of essays entitled *Saggi in onore di Sigmund Freud* to celebrate Freud's eightieth birthday. That same year Ernest Jones, as president of the IPA, was forced to defend his Italian colleagues by writing a

letter to the consul general of Italy in London, protesting the fact that the IPA had never recognized the Italian association. In September 1938, however, the Fascist government instituted race laws, and the SPI was dissolved. Emilio Servadio emigrated to India. In January 1939, Edoardo Weiss emigrated to Chicago, where he stayed for the remainder of his life.

Psychoanalysis in Italy did not resume activities until 1945. Joachim Flescher, a Polish doctor analyzed by Edoardo Weiss, had been very active in psychoanalysis and, by publishing a number of articles, sought to propagate knowledge of the field. In 1947, the SPI was officially reconstituted with Nicola Perrotti as president and with the assistance of Alessandra Wolff Stomersee, Princess Tomasi di Lampedusa (1895–1982), who had trained at the Berlin Institute during the early twenties and had returned to Palermo, where she had a small circle of students.

The review *Psicoanalisi*, founded by Joachim Flescher, became the official mouthpiece of the SPI. Meanwhile, the first Italian Congress of Psychoanalysis was organized in Rome in 1946, followed by a second congress in 1950, also held in Rome. *Psicoanalisi* was published during the years 1945–1946, but in 1948 Nicola Perrotti founded a new review, *Psiche*, which, like its French homonym *Psyché*, created by Marie Choisy, was devoted as much to research as it was to popularization. Within the cultural debate of the time, the speech given by Pius XII on April 15, 1953, played an important part, for, overlooking the reservations of Agostino Gemelli, the Church then recognized the validity of psychotherapy and psychoanalysis. In 1955, the SPI reintroduced *Rivista di Psicoanalisi*, which has remained the official publication to this day. During the next few years some psychoanalysts trained in London by Melanie Klein and her students spread awareness of Kleinian theory in Italy. They included Adda Corti, Pierandrea Lussana, Mauro Morra, and Lina Generali Clementis. The systematic translation of the work of Melanie Klein, Wilfred Bion, Donald Winnicott, Herbert Rosenfeld, Donald Meltzer, and Hanna Segal also had considerable influence on psychoanalysis in Italy.

During the nineteen sixties, the SPI was involved in the creation of a number of local centers primarily devoted to scientific research and involvement in social policy. At the same time, differences regarding training were formalized with the establishment of three institutes—one in Milan and two in Rome—

coordinated by the Commissione Nazionale del Training.

Interest in psychoanalysis among the public at large continued to grow. By the end of the sixties, there were a number of students, doctors and psychologists, surgeons, and psychiatrists, who had begun to look to the SPI, either to begin personal analysis or to seek supervision for their own treatment of others. During the nineteen-seventies and up to the mid-eighties, upon the initiative of Dr. Piero Bellanova (1917–1987), a number of SPI members joined together to form the Società Italiana de Psicoterapie Psicoanalitica (SIPP) (Italian Society of Psychoanalytic Psychotherapy). With help from the Tavistock Clinic in London, the profound interest in the work of Melanie Klein resulted in the creation of schools of child psychoanalysis, first in Rome, then in other cities throughout Italy. In 1979 Professor Adriano Giannotti (1932–1994) created, within the department of child neuropsychiatry at the School of Medicine in Rome, a “Corso di psicoterapia psicoanalitica dell’età evolutiva” (Developmental Psychoanalytic Psychotherapy).

Also in Milan, through the efforts of Professors Cesare Musatti, Franco Fornari (1921–1985), Antonio Imbasciati, Franco Ferradini, Giovanni Carlo Zapparoli, Dr. Enzo Morpurgo, and others, psychoanalysis entered the academic world and local medical institutions by training students and clinicians in psychoanalysis. Prompted by Professor Francesco Corrao (1922–1994), the so-called “Pollaloi” group was formed in Rome in the seventies to study and practice psychoanalysis according to the principles established by Wilfred Bion. A Centro Italiano de Gruppo Analisi (CIGA), inspired by the work of S. H. Foulkes, was also created in the seventies by Alice Ricciardi von Platen. During the seventies and early eighties, seminars were organized in Italy by Wilfred Bion, Donald Meltzer, Marta Harris, and Hanna Segal, which received considerable popular attention.

At the same time the work of Jacques Lacan became known in Italy through the effort of three of Lacan’s own students—Giacomo Contri, Muriel Drazien, and Armando Verdiglione, who, in 1974, with Lacan’s agreement, formed a new association, the Cosa freudiana. The systematic translation of Lacan’s seminars and writings was begun by Giacomo Contri and continued by a student of Jacques-Alain Miller, Antonio di Ciaccia. In 1953, during the Congrès des Psychanalystes de Langues Romanes (Congress of Romance

Language Psychoanalysts), held in Rome, Jacques Lacan introduced his program: “Fonction et champ de la parole et du langage en psychanalyse.” Lacan returned several times to Italy for conferences and seminars. On October 31, 1974, a congress of the École Freudienne de Paris was held in Rome, along with the first Congress (devoted to the topic of culture), held in 1982, of the Mouvement Freudien Internationale (International Freudian Movement), founded in Milan in 1976 by Armando Verdiglione. Verdiglione was arrested in 1986 and charged with “extortion, abandonment of the disabled, and criminal association,” and condemned to four and a half years in prison.

In psychiatry the influence of psychoanalysis was evident in the new concept of mental illness and the new therapeutic methods illustrated by Professor Franco Basaglia (1924–1980). These led to Law 180/78, which profoundly transformed the organization and function of psychiatric hospitals in Italy.

In 1982, in the presence of the president of the republic Sandro Pertini, the Fiftieth Anniversary Congress of the Foundation of the SPI was held in Rome. During the eighties, the society had followed with growing interest the legislative procedure that resulted in the passage of legislation governing psychologists and psychotherapists (Law 56/89). The legislature examined the methods of intervention and engagement with the Italian state and planned to create a “Scuola di Formazione” (Training School) according to the terms of the new law.

Two IPA congresses were held in Rome, in 1969 and in 1989, and a Congress of Romance Language Psychoanalysts, was also held in Rome (1953, 1960) and in Milan (1964). The SPI as a whole and through its members has always maintained close contacts with its sister societies, especially in England and France. At the national congresses, the tenth of which was held in Rimini in 1994, foreign colleagues were always invited to attend. Throughout the eighties an attempt was made to promote interaction among members from different cities, either through seminars held every two years in Bologna or through yearly conferences organized by the center in Palermo. There were also a number of Italian-French colloquia held nearly every year, starting in November 1989.

Among the significant events of the nineteen-nineties were the revision of the bylaws and rules of

the SPI, which dated back to 1974 (1994). Under the impetus of the Site Visit Committee, presided over by Serge Lebovici, a single and unique training institute, currently established in four locations—two in Rome, one in Milan, and one in Bologna—was formed that same year. At the same time a code of professional practice was published. In 1992, a circle of members led by Emilio Servadio and Adriano Giannotti led to the creation of a study group that was recognized by the IPA in 1993 as the Associazione Italiana de Psicoanalisi (AIPsi) (Italian Association for Psychoanalysis). A series of meetings were also held concerning the relation between psychoanalysis and culture, organized annually by the commune of Lavarone under the patronage of the autonomous province of Trento and the SPI. Glauco Carloni, Michel David, Anna Maria Accerboni, and Alberto Schoen assisted in organizing the meetings. The first Italian-Spanish colloquium took place in March 1996.

The theoretical and clinical contribution of Italian psychoanalysts to psychoanalysis merits respect. Aside from the work of Outre Cesare Musatti, who began the translation of the works of Sigmund Freud (OSF, 1967–1980), other important contributions have been made by Niccola Perrotti, Emilio Servadio, Franco Fornari, Eugenio Gaddini, Francesco Corrao, and Ignacio Matte Blanco, the Chilean psychiatrist and philosopher who became a naturalized Italian citizen.

The theoretical investigations concerning the “group field” and “analytic relationship” that characterized Italian psychoanalysis in the 1980s continued into the 1990s. Initiated by analysts who defined the analytic relationship as a system, their point of extra-analytic reference was systems theory while within analysis they relied fundamentally on Freudian metapsychology. Around the same time, Francesco Corrao, a

psychoanalyst from Palermo, developed the group field model, deeply influenced by Wilfred Bion. Both trends developed clinical approaches through an extensive investigation into psychoanalytic methodology and epistemology. Several representatives of the psychoanalytic center of Milan, including Nissim Momogliano, employed not only Bion’s work but the Kleinian-based clinical theory of Willy Baranger. Other Milanese colleagues were influenced by American intersubjective theory, which has gained currency in Europe in recent years.

The Italian Psychoanalytic Society has centers located in ten major cities, each relatively autonomous. Two reviews chart the ongoing development of psychoanalysis in Italy: *Rivista di psicoanalisi*, the official publication of the IPS, and *Psiche*, a journal with broader cultural aims that reaches an audience of specialists in other disciplines.

ROSARIO MERENDINO

### **Bibliography**

- Accerboni, Anna Maria (1988). *Psychanalyse et fascisme: deux approches incompatibles. Le rôle difficile d’Edoardo Weiss. Revue internationale d’histoire de la psychanalyse, 1*, 225–243.
- Bellanova, Piero, and Bellanova, A. (1982). *Le due gradive*. Roma: C.E.P.I.
- Contri, Giacomo (1978). *Lacan in Italia*. Milan: La Salamandra.
- David, Michel (1966). *La psicoanalisi nella cultura italiana*. Turin: Boringhieri.
- Novelletto, Arnaldo (1989). *L’Italia nella psicoanalisi*. Rome: Istituto della Enciclopedia italiana.



### JACOBSON, EDITH (1897–1978)

Edith Jacobson, psychoanalyst and physician, was born September 10, 1897 in Haynau, Germany and died December 8, 1978 in Rochester, New York.

Edith Jacobson's father was a physician and her mother was a talented musician. She attended medical school at Jena, Heidelberg, and Munich, and received her medical degree from Munich in 1922. From 1922 to 1925 she was a pediatric intern at the University Hospital in Heidelberg.

Jacobson traced her interest in psychoanalysis to the period of her pediatrics internship, during which she observed instances of childhood sexuality (Milrod, 1971). In 1925 she began training at the Berlin Psychoanalytic Institute, where her analyst was Otto Fenichel. During these years she also participated in "Das Kinder Seminar," which was formed by candidates at the Berlin Institute and led by Fenichel (the name is an ironic reference to the junior status of its organizers, not to its substantive focus).

In 1934 she was named a training analyst at the Berlin Institute. During the 1930s she was imprisoned by the Nazis because she refused to divulge information about a patient (Kronold, Edward, 1979). During her imprisonment she became seriously ill with Graves disease and diabetes. While hospitalized in Leipzig she was able to escape from Germany with the help of her close friend Annie Reich, and Reich's second husband. In 1941 she emigrated to the United States of America where, as a member of the New York Psychoanalytic Society and Institute, she was a distinguished training analyst and teacher.

The investigation of ego and superego functioning, the processes of identification underlying their

development, and their role in depression were central to Jacobson's theoretical and clinical work. In her writings she sought to construct an overarching developmental perspective which would do justice to both drives and to real objects and their representations in building up of the ego and superego. Jacobson and Heinz Hartmann introduced the concept of self-representation into psychoanalytic theory, and she was particularly interested in the fate of self-representations in depressive and psychotic illness. Her collected papers, *Depression: Comparative Studies of Normal, Neurotic, and Psychotic Conditions* (1971), permit the reader to follow the development of her thinking over the years. *The Self and the Object World* (1964) is Jacobson's main theoretical text. She observes that in psychotic and borderline patients processes of regression lead to severe deterioration of object relations, ego functions, and superego structure and function. This is accompanied by dissolution of the essential identifications on which the experience of identity is founded.

Jacobson's work is "the first attempt to trace, within a strictly psychoanalytic framework, the development of the self . . . and its mental representations" (Tuttman, 1981). She is the first theorist to attempt to integrate drive theory with structural and object relations theory in a comprehensive, developmental synthesis, and her influence on subsequent work in this area has been profound.

NELLIE L. THOMPSON

*See also:* Ego boundaries; Identity; New York Psychoanalytic Institute; Object relations theory; Primary identification; Self; Self-representation.

### Bibliography

- Jacobson, Edith. (1964). *The self and the object world*. New York: International Universities Press.
- . (1971). *Depression: Comparative studies of normal, neurotic and psychotic conditions*. New York: International Universities Press.
- Kronold, Edward. (1979). Edith Jacobson, 1897–1978. *Psychoanalytic Quarterly*, 49, 505–507.
- Milrod, David. (1971). *Oral history interview with Edith Jacobson*. New York: A.A. Brill Library, New York Psychoanalytic Institute
- Tuttman, Saul. (1981). The significance of Edith Jacobson's *The Self and the Object World* in contemporary object relations theory. In C. Kaye M. Zimmerman, S. Tuttmann (Eds.): *Object and self: A developmental approach, essays in honor of Edith Jacobson* (p. 81–102). New York: International Universities Press.

## JAHRBUCH DER PSYCHOANALYSE

It was decided at the 1908 Salzburg congress on Freudian psychology to create a periodical that reflects the specialization and specificity of psychoanalysis. In 1909 the publisher F. Deuticke launched the *Jahrbuch für psychoanalytische und psychopathologische Forschungen* (Annals of Psychoanalytic and Psychopathological Research), a periodical specializing in psychoanalysis, the first of a series of psychoanalytic publications to appear over the following years. Eugen Bleuler and Sigmund Freud were the editors, and Carl Gustav Jung was in charge of the writing.

With the appearance of this publication, the psychoanalytic movement that had built up around the congresses and in private associations acquired an autonomous literary profile. Previously dispersed in different medical journals, psychoanalytic articles were now grouped together in a single publication and made available not only to medical circles but also to the growing lay public. The interdisciplinary interests of readers caused the *Jahrbuch* to publish many articles by pioneers of applied psychoanalysis, alongside more detailed case histories. Moreover, as Freud pointed out to Jung, because the audience was clearly defined, it did not need to be constantly reminded of either the foundations of psychoanalytic theory or the criticisms, and so more space could be devoted to new developments in analytic theory.

The first divisions to shatter the analytical world between 1911 and 1913 also translated into conflicts for

editorial control of publications. Wilhelm Stekel took over control of the *Zentralblatt für Psychanalyse*, and after the resignation of Jung and Bleuler in 1914, Freud continued as the sole director of the *Jahrbuch*, with Karl Abraham and Eduard Hitschmann as editors.

The rupture with Jung and his followers was reflected in the new title: *Jahrbuch der Psychoanalyse* (Annals of Psychoanalysis). The first issues of the new *Jahrbuch* was devoted entirely to defining the theoretical territory of psychoanalysis in relation to the positions of Carl Jung and Alfred Adler. The two works by Freud that it published—“*On the History of the Psycho-Analytic Movement*” (1914a) and “*On Narcissism*” (1914b)—defined new frontiers for psychoanalysis with polemical acuity.

In spite of this transformation of the *Jahrbuch*, it proved to be impossible to publish it on a regular basis. Because of the reduced number of subscribers caused by the war, Deuticke suspended publication after only one year.

LYDIA MARINELLI

See also: Germany.

### Bibliography

- Freud, Sigmund. (1914a). On the history of the psychoanalytic movement. *SE*, 14: 1–66.
- . (1914b). On narcissism: An introduction. *SE*, 14: 67–102.
- Jones, Ernest. (1953–1957). *Sigmund Freud: Life and work* (3 vols.). London: Hogarth.
- Jung, Carl Gustav. (1947 [1954]). On the nature of the psyche. *Coll. works* (Vol. 8). London: Routledge & Kegan Paul.

## JALOUSIE AMOUREUSE, LA

The two volumes of this work correspond to Daniel Lagache's PhD thesis, presented in 1947. The subheading (*Descriptive Psychology and Psychoanalysis*) clearly states Lagache's intention of producing a study at the intersection of his experience and multidisciplinary training as a philosopher, psychiatrist, psychologist, and psychoanalyst.

Lagache conducted an exhaustive study of the different authors who dealt with the question of jealousy.

His work was based on fifty essentially personal clinical cases, most of them in institutions, and a few cases of analytic treatment for which he presents an ample amount of material. In the first volume he sets out to describe and classify states of jealousy; the second deals with jealousy as it is actually experienced.

“Amorous jealousy derives from a conflict between jealous (possessive) love and reality, jealous love constituting a demand for total and exclusive possession of the partner.”

But jealousy extends beyond the context of the love relationship and becomes a manner of existing (an essential part of which is devoted to passionate and instinctual life), so in fact the distinction between normal and pathological jealousy is a matter of degree and not of essence. The onset of jealousy may be exacerbated by concomitant factors creating a situation of insecurity and frustration that strikes an echo with situations of frustration in childhood, with hyperemotive and impulsive reactions that Lagache considers to be predisposing factors for jealousy. Jealousy may occupy a subordinate position in all clinical cases, but seems to have an elective affinity for the paranoid mode of psychic organization characterizing a relatively primitive level of functioning of the person and of their relations with others.

In the second volume he studies how greed, linked with covetousness in envy and possession in jealousy, can blend with the feeling of love because jealousy is distinct from envy in that we are “jealous of what we possess and envious of what others possess.” He distinguishes three types of love relations: communion-love, oblation love and captative love. Captative love implies jealousy and the desire for total, physical and moral possession of the partner, who is then compared to the ideal object and totally ignored in their otherness (sexuality, violence). Jealousy avoids the internal conflict by displacing it to a conflict with the exterior, which is experienced as a demand for atonement based on an impression of injustice. This can go as far as homicidal jealousy in which, over and above the reality of the victim, the whole of interhuman reality is denied.

RÉGINE PRAT

*See also:* Castration complex; Lagache, Daniel; Neutrality/benevolent neutrality; Oedipus complex; Paranoia; Passion; Psychoses, chronic and delusional; “Psycho-Analytic

Notes on an Autobiographical Account of a Case of Paranoia (Dementia Paranoides)”.

### Source Citation

Daniel, Lagache. (1947). *La Jalousie amoureuse. Psychologie descriptive et psychanalyse*. Paris, Presses Universitaires de France.

---

## JANET, PIERRE (1859–1947)

Pierre Janet, a French physician and philosopher, was born in Paris on May 30, 1859; he died there on February 23, 1947. Janet spent his entire life in Paris, except for his years as a teacher and his travels abroad.

For fifty years (1889 to 1939) Janet was, along with Henri Bergson, the most famous French psychologist in the world, the student of two of the greatest minds in French psychopathology, Jean Martin Charcot and Théodule Ribot. Attempts were made to turn Janet into an unfortunate rival of Freud during the controversy over the discovery of hysteria.

Born into a middle-class Catholic family, he was deeply influenced by his uncle Paul Janet, a well-known spiritualist philosopher. As a philosopher and physician, Janet had the educational background of the ideal psychologist outlined by Ribot.

He entered the *École Normale Supérieure* in 1879, received his degree in philosophy in 1882, and was appointed professor of philosophy at the *Lycée du Havre* in 1883. There he began collecting material for his dissertation, and in 1889 presented the oral defense of his doctoral dissertation, “*L’automatisme psychologique, essai de psychologie expérimentale sur les formes inférieures de la vie mentale*.” It is based on experiments Janet conducted, in the department of Doctors Gibert and Powilewicz, on hypnotism, somnambulism, and suggestion with one of his most famous patients, Léonie. Janet insisted on the role of unconscious obsessions in the genesis of hysteria and the possibility of their disappearance through hypnosis and suggestion.

His work attracted the attention of Théodule Ribot, who in 1895 recommended him as his successor as professor of psychology at the *Collège de France*, which he did in 1902, and of Jean Martin Charcot, who in 1890 created for Janet a laboratory of psychology at the *Salpêtrière Hospital*. Charcot died in 1893,



immediately after Janet's defense of his medical dissertation, "L'état mental des hystériques." Although hysteria and hypnosis had been almost universally criticized, Janet, with the help of Fulgence Raymond, was able to continue working, and wrote several important works, which he cosigned with Raymond. But upon Raymond's death in 1910, Jules Déjerine fired him from the laboratory at the Salpêtrière. And in 1912 Henri Piéron was chosen, in place of Janet, as head of the Laboratory of Physiological Psychology at the Sorbonne. Janet's only institutional support at this time consisted of his courses at the Collège de France, where he taught the psychology of behavior, emphasizing genetic and social factors.

At the Seventeenth Congress of Medicine in London, in 1913, he presented a paper on "Psychoanalysis." This period, the culmination of his public dispute with Sigmund Freud, ended, as many observers concluded, with his defeat and the decline of his stature. His theories on hysteria were supposedly more rational than Freud's, and were based on the idea of mental depression that was said to be the origin of a narrowing of the field of consciousness, of "subconscious" obsessions, and the dissociation of systems of images and functions that normally constituted consciousness. With respect to etiology he also insisted on the importance of a predisposition, since dissociation was acquired, and the presence of some form of emotional trauma; sexuality did not play any special role in this. In his therapy he used suggestion under hypnosis, providing a non-traumatic substitute for the obsessions associated with events that were said to be the cause of the disease.

Although Janet modified his positions later on, Freud would never forget his criticisms and remained deeply upset by the efforts of French psychologists and psychoanalysts to give Janet priority in the essential discoveries of psychoanalysis. Marie Bonaparte and Édouard Pichon (who became Janet's son-in-law) tried to reconcile the two men, but in vain.

The founder, in 1904, along with Georges Dumas, of the *Journal de psychologie normale et pathologique*, Janet published a number of books, including *Névroses et Idées fixes* (1898) and *Les Médications psychologiques* (1919–1921). In 1926 he published his major work, *De l'angoisse à l'extase*, where he described the case of Madeleine, who suffered from mystical delusions and whom he treated for twenty years, analyzing the psychology of belief and its pathology.

Janet continued teaching until 1935 and, following his retirement, continued to write articles and even to see patients until 1942 at the Sainte-Anne Psychiatric Hospital in Paris. When he died on February 23, 1947, he was working on a paper on the psychology of belief.

ANNICK OHAYON

*See also:* Automatism; Case histories; Charcot, Jean Martin; Compulsion; Estrangement; France; Hypnosis; Intellectualization; Narco-analysis; Obsessional neurosis; Obsession; Phobias in children; Pichon, Edouard Jean Baptiste; Psychology and psychoanalysis; Salpêtrière Hospital, La; *Studies on Hysteria*; Subconscious; Suggestion.

### Bibliography

- Ellenberger, Henri F. (1970). *The discovery of the unconscious: The history and evolution of dynamic psychiatry*. New York: Basic Books.
- Janet, Pierre (1889). *L'Automatisme psychologique: essai de psychologie expérimentale sur les formes inférieures de la vie mentale*, dissertation. Paris: Félix Alcan; reprinted Société Pierre-Janet, 1973.
- . (1914, March–April). La psycho-analyse. *Journal de psychologie normale et pathologique*, 11 (1–3), 98–130.
- . (1926). *De l'angoisse à l'extase. Étude sur les croyances et les sentiments*. Paris: Félix Alcan.

## JANKÉLÉVITCH, SAMUEL (1869–1951)

Samuel Jankélévitch, a physician, was born in Odessa, Russia, on April 30, 1869, and died in Paris in 1951. He was one of the first French translators of the work of Sigmund Freud.

Affected by the discriminatory laws that affected Russian Jews in 1880, he traveled to France and studied medicine in Montpellier, then in Bordeaux. He married Anna Ryss. The couple had three children, one of whom, Vladimir, became a well-known philosopher. Jankélévitch practiced medicine in Bourges, then moved to Paris, where he remained until the Second World War. He published two books of his own: *Nature et société* (Nature and society; 1906) and *Révolution et tradition* (Revolution and tradition; 1947), together with a handful of articles in medical and applied psychology journals. His books reflect his interest in spiritualist philosophy rather than medicine. The remainder of his publishing activity consists of translations. These

were numerous and eclectic: philosophy, history, anthropology, sociology, biology, psychology, and psychoanalysis.

In the 1920s and 1930s he worked for Payot, translating not only the works of Sigmund Freud, but also those of Ernest Jones and Otto Rank. In spite of reservations concerning the difficulties for a nonanalyst in translating certain concepts or works (at the time there were no trained psychoanalysts in France), Freud allowed Payot to publish his *Introductory Lectures on Psycho-Analysis* in 1922, with Jankélévitch as translator.

In the preface of the book Jankélévitch states that he is less interested in championing the theories he is translating than in making them known to the French public to dispel common prejudices. There followed translations of *The Psychopathology Of Everyday Life* in 1922, and *Totem and Taboo* and *Group Psychology and the Analysis of the Ego* in 1924. After 1927 he stopped translating Freud, and in any case ceased to be Freud's sole translator in France: Blanche Reverchon, Hélène Legros, Ignace Meyerson, and Marie Bonaparte were also working on Freud texts. With competition from Alcan and Gallimard, Payot also lost its publishing monopoly over Freud.

Ironically, Jankélévitch died in 1951 while preparing a work on Tolstoy and death.

ANNICK OHAYON

See also: France; Translation.

### **Bibliography**

Jankélévitch, Samuel. (1906). *Nature et société*. Paris: Félix Alcan.

———. (1947). *Révolution et tradition*. Paris: J.-B. Janin.

---

## **JAPAN**

The period before World War II is the first important period for psychoanalysis in Japan.

Kiyoyasu Marui went to the United States in 1919 to study with Adolf Meyer at Johns Hopkins University. Witnessing the influence of psychoanalysis on American psychiatry, he hoped to introduce psychoanalysis to the Japanese. After returning to Japan, he began teaching at the University of Tohoku in Sendai (in northeastern Japan). Psychoanalysis became the

focus of his medical school lectures on psychiatry. In 1933, Marui visited Freud in Vienna and received approval for establishing a Sendai Branch of the IPA.

Heisaku Kosawa, a student of the Tohoku School, left Japan to study at the Vienna Psychoanalytic Institute from 1932 to 1933. He received training analysis from Richard Sterba, and individual supervision on psychotherapy from Paul Federn. While in Vienna, furthermore, Kosawa visited Freud at his home at Bergasse 19 and interviewed him directly. He presented Freud with a paper explaining his theory of the Ajase complex, which he contrasted with Freud's Oedipus complex. Unfortunately, Freud does not appear to have evinced great interest in Kosawa's thesis. After returning to Japan in 1933, Heisaku Kosawa opened a private clinic in Tokyo. Here he began practicing psychoanalytic therapy as it was known in Europe and the United States.

With the outbreak of World War II in 1939, Japan became an ally of Nazi Germany, which regarded psychoanalysis as a dangerous, Jewish system of thought. Kosawa came under constant surveillance from the special police. Nevertheless, he continued to conduct a private practice throughout the war.

The end of World War II brought an influx of learning and culture from the United States, which greatly influenced all aspects of Japanese society including the field of psychiatry. It created a generation of young psychiatrists who sought to study the model of American dynamic psychiatry. They chose to receive training analysis and individual supervision from Kosawa. This group of psychiatrists who studied under him became the second generation of Japanese psychoanalysts, known as the Kosawa School. Some leading members included Takeo Doi, Masahisa Nishizono, and Keigo Okonogi.

After the death of Kiyoyasu Marui in 1953, Kosawa changed the name of the Sendai Branch to the Japan Branch which is known internationally as the Japan Psychoanalytic Society. Psychiatrists who received training analysis from Kosawa between 1950 and 1960 represent its core members.

In 1969, following the death of Heisaku Kosawa, Michio Yamamura succeeded to the presidency of the Japan Psychoanalytic Society. The period 1960–1970 also witnessed the return of several Japanese psychiatrists from clinical work abroad. Boosted by the participation of these third-generation psychiatrists,

psychoanalysis gradually gained importance in Japan, and became a major influence in the field of clinical psychiatry. From the 1950s to the 1960s, Japanese psychoanalysis was greatly influenced by psychoanalysis in the United States, especially ego psychology (Heinz Hartmann, Anna Freud, Paul Federn, Erik Erikson). In terms of clinical practice, it was during the period from 1960 to 1970 that the diagnosis and psychotherapy of borderline cases, as well as classic psychoanalytic therapy, began to attract keen attention.

During the 1980s, Japanese translations appeared for most of the essential works of object relations and Kleinian theorists. From 1980 onwards, a growing number of psychoanalysts from overseas, particularly from the United States, began to visit Japan. Leading American psychoanalysts such as Otto Kernberg and Arnold Cooper conducted the first international seminar in Tokyo, on borderline cases and narcissism. Numerous psychoanalysts from other countries followed, resulting in a dramatic increase in the number of seminars and lectures held in Japan. Leading IPA analysts, including former IPA presidents Robert Wallerstein, Serge Lebovici, and Joseph Sandler, came to Japan on various occasions to give lectures and organize seminars. As representative of IPA's Asian Committee, Ramon Ganzarain and Elizabeth Bianchedi, meanwhile, visited Japan numerous times to conduct lectures and supervisions, and Serge Lebovici, Robert Emde, Joy Osofsky, and Peter Fonagy came for the World Association for Infant Mental Health (WAIMH) Regional Meeting Tokyo.

In 1995, the Japan Psychoanalytic Society established new regulations in line with the education and training criteria set forth by the IPA. It also plans to increase the number of training analysts, and to implement training analyses in accordance with international standards. Along with the implementation of these new regulations, the Society has begun making efforts to establish a psychoanalytic institute covering all of Japan.

Japanese psychiatrists' and psychologists' study of psychoanalytic thought generated an encounter between Western and Japanese culture. Indigenous Japanese patterns of thought merged with the imported theory of psychoanalysis, paving the way for such theories as those of *amae* (Tako Doi), the Ajase complex (Heisaku Kosawa, Keigo Okonogi), and the prohibition of "Don't look" (O. Kitayama). These theories aid in understanding the mentality not only of the Japanese,

but also of people from other cultures; they furthermore promise to contribute greatly to psychoanalytical understanding itself. Japanese psychoanalysts strive to continue making significant theoretical contributions to the international community.

KEIGO OKONOJI

### **Bibliography**

Okonogi, Keigo. (1995). A history of psychoanalysis in Japan. In Peter Kutter (Ed.), *Psychoanalysis international, a guide to psychoanalysis throughout the world* (Vol. 2). Stuttgart-Bad Cannstatt: Frommann-Holzboog.

---

### **JEKELS (JEKELES), LUDWIG (1867–1954)**

Ludwig Jekels, an Austrian psychiatrist, was born on August 15, 1867, in Lemberg, Austria, now L'viv, Ukraine, and died on April 13, 1954, in New York.

Jekels (Jekeles until 1903) remained in Lemberg until the end of his secondary studies, and received his baccalaureate in 1885. He went on to study medicine in Vienna and became a doctor of medicine in 1892. In 1897, after five years of training at the Vienna University clinic, he founded an institute for hydrotherapy in Silesia. He then worked as a psychiatrist in Warsaw. In 1905 he returned to Vienna and began psychotherapy with Sigmund Freud. In 1908 he participated in the first congress of the International Psychoanalytical Association in Salzburg.

After 1909 he was often invited to attend meetings of the Vienna Psychoanalytic Society, and he became a member in 1910. Jekels attempted to introduce psychoanalysis in Poland and translated Freud into Polish. After the First World War he worked as a training analyst in Vienna. He also presented a number of lectures at the Vienna Academic Association for Medical Psychology. In 1932 he became substitute director of the admissions board of the Vienna Society for Psychoanalysis. In 1934, together with Otto Fenichel, he traveled to Stockholm to help found the Svensk-Finska Psykoanalytiska Föreningen (Swedish-Finnish Psychoanalytic Association). He returned to Vienna in 1937 but had to leave again in 1938 when Germany annexed Austria.

Passing through Australia, Jekels emigrated to the United States. He settled in New York, where he began working as a psychoanalyst. The New York

Psychoanalytic Society made him an honorary member in 1941. He died there in 1954. Jekel's *Selected Papers* were published in 1952.

HARALD LEUPOLD-LÖWENTHAL

*See also:* Lehrinstitut der Wiener psychoanalytischen Vereinigung; Poland; Shakespeare and psychoanalysis; Tegel (Schloss Tegel); Wiener psychoanalytische Vereinigung.

### Bibliography

- Jekels, Ludwig. (1909). Leczenie psychonewroz za pomoca metody psychoanalizy Freuda, tudziej kazuistyka. *Med. Kron Lek*, Warsaw.
- . (1913). Einige Bemerkungen zur Trieblehre. *Internationale Zeitschrift für Psychoanalyse*, 1, 439–443.
- . (1914). Der Wendepunkt im Leben Napoleons I. *Imago*, 3, 313–381.
- . (1936). Die psychoanalytische Therapie. *Svenska Laekartidn*, 33, 1797–1802, 1821–1831.
- . (1952). *Selected papers*. London: Imago Publishing Co.

### JELLIFFE, SMITH ELY (1866–1945)

Smith Jelliffe, an American psychiatrist, was born in Brooklyn, New York, on October 27, 1866, and died in Lake George, New York on September 25, 1945. His father was a school principal. He studied at Brooklyn Polytechnic Institute and graduated in 1888. He went on to study medicine at the College of Physicians and Surgeons of Columbia University and obtained his doctorate in 1889. After working at St. Mary's Hospital in Brooklyn for a while, he traveled on several occasions to Switzerland and Italy. In 1894 he married Helena Dewey Lemming; they had three daughters and two sons. After becoming a widower he remarried Bee Dobson in 1920.

Jelliffe had always been interested in the literature of the natural sciences and psychology. In the summer of 1896 he met William Alanson White at Binghamton State Hospital, and the two men became close friends. Jelliffe had a brilliant career in neurology and psychiatry, becoming Clinical Professor of Mental Diseases at Fordham University (1907–1912), president of the New York Psychiatric Society, the New York Neurological Society, and the American Psychopathological Association, co-editor, then editor-in-chief of

the *Journal of Nervous and Mental Diseases* in 1912, and corresponding member of the French and Brazilian neurological societies. He was the author of more than four hundred articles. His *The Modern Treatment of Nervous and Mental Diseases*, which he co-authored with William Alanson White, appeared in 1913 and has been a classic in the field, with many reprintings.

He met Carl Gustav Jung during the tumultuous Amsterdam congress of 1907 and became interested in Freudian theories, primarily as a way to understand the relationship between body and mind. Not incidentally, this led to his becoming one of the pioneers of psychosomatic medicine. In 1912 he invited Jung to give a series of eight lectures at Fordham University in New York. In 1913, together with William Alanson White, he founded *Psychoanalytic Review*, the first English-language publication devoted to psychoanalysis — and one that was strongly opposed by Ernest Jones. Jelliffe wrote a number of articles on psychoanalytic technique, daydreams, and transference. During one of his many trips abroad, he presided over the July 21, 1928, session of the third *Conférence des Psychanalystes de Langue Française* (Conference of French-Language Psychoanalysts) in Paris. According to Paul Roazen, it was during this period that he was analyzed by Paul Federn (Roazen, 1976).

His most important contributions were made in the field of psychosomatic medicine. These were collected in his *Sketches in Psychosomatic Medicine*. His attachment to Charles Darwin's theories led him to promote the field of "paleopsychology" to study the psychological determinants of somatic illnesses. "An organ is a structured piece of experience and a tissue of memories," he wrote in 1923.

According to Abraham Arden Brill, "Jelliffe was the father of American psychosomatic medicine, and it is pleasing to learn that Freud always credited him with this." Freud wrote to Jelliffe on October 2, 1933, concerning an offprint he had just received: "This is an additional element of the medicine of the future you are in the process of preparing." And in February 1939 he wrote: "I know that you have been one of my most sincere and loyal adherents over the years" (in Lewis, 1966).

ALAIN DE MIJOLLA

*See also:* United States.

### Bibliography

- Jelliffe, Smith Ely. (1922). Psychopathology and organic disease, *Archives of Neurology and Psychiatry*, 8, 639–651.
- . (1939). *Sketches in psychosomatic medicine*. Washington and New York: Nervous and Mental Disease.
- Lewis, Nolan. (1966). Smith Ely Jelliffe 1866–1945: Psychosomatic medicine in America. In Franz Alexander, S. Eisenstein, Martin Grotjahn (Eds.), *Psychoanalytic pioneers* (pp. 224–234). New York and London: Basic Books,
- Oberndorf, Carl P. (1945). Smith Ely Jelliffe. *International Journal of Psycho-Analysis*, 26, 186–188.
- Roazen, Paul. (1976). *Freud and his followers*. New York: Alfred A. Knopf.

### JOKES

A “joke” is an incongruous or tendentious verbal message, which, by discharging its psychic energy, gives the listener pleasure. Characteristically a joke is not fabricated (manufactured); rather it emerges as a spontaneous, involuntary idea (*Einfall*) and briefly returns the person to an infantile mode of cognition. Wit is, according to Freud, “the most social of activities, designed to provide pleasure through the simple and disinterested activity of the psychic apparatus” (1905c).

Freud devoted an important work, *Der Witz und seine Beziehung zum Unbewussten* (*Jokes and Their Relation to the Unconscious*, SE, 8), to jokes and their relation to the unconscious (1905c). Published five years after *The Interpretation of Dreams* (1900a), this essay confirmed the usefulness of the principal processes it described, such as the transformation of thoughts into images (metaphor), condensation, and displacement. Like *The Psychopathology of Everyday Life* (1901b), the book marks the extension of psychoanalysis beyond the field of psychopathology, without using the method of analysis, but yet offering another area where it could be rediscovered. This interest in word play is found in some of Freud’s later work (the contradictory meanings of primitive words, dreams in folklore, language, and schizophrenia), though not in respect to work on literature or the development of civilization.

The concept analysis of wit is important because it allows a description of psychic processes and thus delineates the development of pleasure from a topographical, economic, and dynamic perspective. Thought

processes in *The Project for a Scientific Psychology* (1950c [1895]) are here approached from a different angle, thus going beyond that found in *The Interpretation of Dreams*. Every successful joke indicates a victory against the inhibition that critical reason imposes on thought in the normal waking psychic state. Unlike dreams, there is no need for secondary elaboration or disguise to escape censorship. However, the joke must occur in a situation when the play of words or nonsense presents itself in a form “that is both admissible [a joke] and ingenious [wit] by virtue of the multiple meanings of words and the infinite variety of negative relations” (1905c).

Technically, the joke is related to the dream but it must take into account its audience and the listener’s ability to correct the distortions (displacements, condensations) through which sense is communicated through non-sense. The goals of dreams and jokes should not be confused. The first tends to express a desire by eliminating unpleasure, while the second is an extension of the game that seeks to obtain some additional pleasure.

Considered from the economic viewpoint, the joke is also similar to the dream (condensation) through its conciseness and, consequently, its psychic economy. This conciseness is not the result of conscious effort but the consequence of unconscious processes’ effect on preconscious thought, which is then recovered in consciousness. This development consists in letting certain elements fall by the wayside and overdetermining others that will remain, thereby obtaining much greater impact.

Freud’s work on jokes has largely been misunderstood, although it introduces new perspectives on aggression, the thought process, the production of pleasure, and infantile mental activity (see *Three Essays on the Theory of Sexuality*, 1905d). It wasn’t until Donald Winnicott that theoretical work on children’s jokes and their connection to creativity was taken up again, a prospect foreseen by Freud in these terms: “In doing so they come across pleasurable effects, which arise from a repetition of what is similar, a rediscovery of what is familiar, similarity of sound, etc., and which are to be explained as unsuspected economies in psychical expenditure” (1905c). Games with words and thoughts serve as the point of departure not only for the pleasure of jokes but the “pleasure of thinking” (Mijolla-Mellor, 1990), which includes critical reason

in its scope but escapes its inhibitory effect through the creative process that is set in motion.

SOPHIE DE MIJOLLA-MELLOR

*See also:* Children's play; Condensation; Formations of the unconscious; Humor; *Jokes and Their Relation to the Unconscious*; Pleasure/unpleasure principle; Repetition; Sense/nonsense; Signifier/signified; Sudden involuntary idea; Work (as a psychoanalytic notion)

### **Bibliography**

- Freud, Sigmund. (1905c). Jokes and their relation to the unconscious. *SE*, 8: 1–236.
- Kohn, Max. (1991) *Mot d'esprit et Événement*. Paris: L'Harmattan.
- Lacan, Jacques. (1998). *Le Séminaire-Livre V, Les Formations de l'Inconscient (1957–1958)*. Paris: Le Seuil.
- Rolland, Jean-Claude. (1996) Du rêve au mot d'esprit, la fabrique de la langue, *L'inactuel*, 5, 91–105.
- Safouan, Mustapha. (1988) Désir et mot d'esprit. *Apertura*, 2, 93–97.

### **Further Reading**

- Gilman, Sander L. (1984). Jewish jokes: Sigmund Freud and the hidden language of the Jews. *Psychoanalysis and Contemporary Thought*, 7, 591–644.

---

## **JOKES AND THEIR RELATION TO THE UNCONSCIOUS**

Freud wrote *Jokes and Their Relation to the Unconscious* (1905) at nearly the same time as *Three Essays on the Theory of Sexuality* (1905), but here pleasure is approached from the angle of wit and its mechanisms and motives. In this work Freud further develops his principal discoveries on mental activity elaborated in *The Interpretation of Dreams* (1900), a text already containing a reference to wit in the structure of dreams.

*Jokes and Their Relation to the Unconscious* is divided into three sections: analytic, synthetic, and theoretical. As in *The Interpretation of Dreams*, Freud discusses at length the theories of philosophers (Theodor Vischer, Kuno Fischer, Theodor Lipps) and writers (Jean Paul, Heinrich Heine, Georg Lichtenberg), and gives examples from Jewish folklore in the self-analytical part of the book. This self-analysis is as essential

here as it was in Freud's *Interpretation of Dreams* and *The Psychopathology of Everyday Life* (1901).

The first part (analytic) is essentially descriptive: the mechanisms of jokes makes use of the principal elements of dream work, which Freud summarizes, providing an overview of the techniques used in telling jokes. As with dreams, these mechanisms are unconscious and can only be determined after the fact. But to these mechanisms Freud adds the element of meaning, that is, the aims of wit, the pleasurable or hostile satisfaction obtained in telling jokes. It is this meaning that makes his investigation of jokes profound.

The second part (synthetic) investigates the pleasure of jokes and its mechanisms and psychogenesis. Building on the work of Gustav Theodor Fechner, Freud developed an economic perspective based on the notion of mental economies. Here he makes use of ideas developed earlier in the *Project for a Scientific Psychology* (1950c [1895]). The distinction between jokes and the comic allowed Freud to emphasize that the former is essentially a social activity requiring the presence of a third party. The activity is further complicated by the fact that group as well as individual dynamics are at play: "Why are we driven to tell our own joke to someone else? . . . [B]ecause we are unable to laugh at it ourselves" (Freud, 1905c, p. 190).

The third part (theoretical) returns to the comparison between dreams and jokes, but from the point of view of the unconscious. Freud indicated that he hoped to convince readers of the richness of the hypotheses presented in 1900, which were often reduced to the simplistic idea of "wish fulfillment." He also related his theories to those of Theodor Lipps and noted "there is a return of the mind in dreams to an embryonic point of view" (p. 211). In the pleasure of jokes, adults rediscover the infantile as a source of the unconscious, as illustrated by play with words and thoughts. The chapter closes with an analysis of the varieties of the comic, which is more difficult to analyze because it is not a process elaborated like a dream or joke but an encounter with a situation. According to Freud, "The comic arises in the first instance as an unintended discovery derived from human social relations" (1905c, p. 234). The production of the comic (imitation, caricature) highlights a narcissistic aspect of the psyche, that is, the comparison of self and other.

The book concludes with some of Freud's subtlest and richest ideas about the subject, namely the

distinction between humor and irony. He returned to this distinction in his short article on humor in 1927.

Though this book has not always received the attention it deserves, it is definitely an important work. Lacan (1998) discussed it in his seminar on the formations of the unconscious. Theodor Reik (1935) related Freud's economic perspective on jokes to the concepts of surprise and discovery.

SOPHIE DE MIJOLLA-MELLOR

*See also:* Jokes.

### Source Citation

Freud, Sigmund. (1905). *Der Witz und seine Beziehung zum Unbewussten*. Leipzig: Deuticke. G.W., VI. Jokes and their relation to the unconscious. *SE*, 8.

### Bibliography

Freud, Sigmund. (1900a). The interpretation of dreams. *SE*, 4: 1–338; 5: 339–625.

———. (1901). The psychopathology of everyday life. *SE*, 6.

———. (1927). Humour. *SE*, 21: 159–166..

———. (1950c [1895]). Project for a scientific psychology. *SE*, 1: 281–387.

Lacan, Jacques. (1998). *Le séminaire*. Book 5: *Les formations de l'inconscient*. Paris: Seuil.

Reik, Theodor. (1935). *Surprise and the psycho-analyst: on conjecture and comprehension of unconscious processes*. London: Kegan Paul, Trench, Trubner.

---

## JONES, ERNEST (1879–1958)

Ernest Jones, a British psychoanalyst, was born at Gowerton, Glamorgan, Wales, on January 1, 1879, and died in London on February 11, 1958. The product of a middle-class Welsh family, Jones was educated at Swansea Grammar School and University College, Cardiff, and received his medical training at University College Hospital, London. His interests at this early stage of his career included clinical medicine, surgery, neurology, pathology, and also clinical psychiatry. He qualified in 1900 for a gold medal in the London M.D. examination. He became a member of the Royal College of Physicians in 1904 and received a Diploma of Public Health (Cambridge) in 1905. After qualifying, he held various hospital appointments and published several papers on childhood and adult neurological diseases.

In 1906, with his friend Lewis Trotter, he discovered Freud's writings, and this stimulated his interest in the German language. In 1907, as a graduate student, he went to Munich, where he discovered German neurology and psychiatry.

Psychoanalysis and the new interest in the emotional life of the individual brought about a deep change in him. In April 1908 he visited Vienna with Abraham Arden Brill, met Sigmund Freud for the first time, and discussed plans on how to translate and propagate Freud's work in the Anglo-American world. In a paper written in the same year and given at the International Psychoanalytical Congress at Salzburg, Jones coined the term "rationalization," which was accepted by Freud and became part of the technical language of psychoanalysis to indicate a way of trying to make sense of unconscious motivations by rationalizing them. Partly because of a series of severe setbacks that broke the progression of his career in London, in 1909 he emigrated to Canada, where he became Associate Professor of Psychiatry at the University of Toronto.

While in Canada, Jones was in touch with neurologists and psychiatrists in the United States. He became assistant editor of Morton Prince's newly founded *Journal of Abnormal Psychology*, in which he published several papers on psychoanalysis. He also organized the American Psychoanalytic Association, intended for psychoanalysts scattered all over the United States. In the meantime, he kept in touch with Freud in Vienna and accompanied Freud when the latter visited the United States to lecture at Clark University.

After he returned to England in 1913, Jones undertook a short personal analysis with Sándor Ferenczi. During the same year he founded the London Society of Psychoanalysis, but he eventually dissolved the society because some of his important followers favored Carl Gustav Jung. During the years of the First World War, Jones continued practicing as a private analyst in London and also lecturing widely on psychoanalysis both in London and outside, contributing to the gradual diffusion of the new discipline in the medical profession, which was highly resistant, and among the larger public. Particularly important were his contributions on the subject of shell-shock neuroses.

In 1919 Jones founded the British Psycho-Analytical Society. Having lost his first wife in 1918, in 1919 he married the Viennese Katherine Jokl. Shortly

thereafter, in 1920, he established the International Psychoanalytical Press in collaboration with the Hogarth Press, founded the International Journal of Psycho-Analysis, which he edited from 1920 to 1939, and coordinated a group of translators—including James and Alix Strachey, Joan Riviere, and John Rickman—in the first systematic translation of Freud's works into English. As early as the 1920s Jones put forth the idea of a standard edition of Freud's work. To him we owe many of the English terms of Freud's technical language. Jones played a fundamental role in helping Melanie Klein to come to England in 1926.

Prior to the Second World War he effectively ruled psychoanalysis in England and had enormous influence in organizing the international psychoanalytical movement, the result being the International Psychoanalytical Association. Significant were his struggle to achieve scientific status for psychoanalysis in England, his attempts to develop the British way of looking at psychoanalysis, and his defense of Klein's views against the severe criticisms of Freud and his daughter Anna, while managing to remain a good friend and collaborator of Freud and to continue his own scientific production. Jones also became president of the International Psychoanalytical Association, a position he held for 17 years in total and finally relinquished in 1949.

In the late 1930s, when the pressure of the Nazi persecution of Jews made life impossible for his colleagues in Berlin, Vienna, and Budapest, Jones, with the help of his American colleague Brill and Marie Bonaparte, managed to get nearly fifty European psychoanalysts out of their countries first to England and then mainly to North America. Particularly important was the rescue of Freud and his family in 1938. Jones played an important role in trying to mediate between Anna Freud and Melanie Klein during the so called "controversial discussions" in the early 1940s. In 1946 he retired from the active life of the British Psycho-Analytical Society to the Plat, his beautiful cottage in Sussex. He devoted the last ten years of his life to writing Freud's biography *The Life and Work of Sigmund Freud* (1953–1957) and his autobiography *Free Associations* (1959), as well as to collecting and reediting some of his clinical papers *Papers on Psycho-Analysis* (1948), despite a cancer of the bladder, which eventually killed him.

Jones was undoubtedly the finest organizer and politician in the first generation of Freud's followers.

Without his prodigious energy and enormous work, psychoanalysis, both in the Anglo-American sphere and the world at large, would not have been able to assert itself as it did. Yet no one should forget Jones's theoretical and clinical contributions to psychoanalysis and his wide interest in applied psychoanalysis. His notion of female aphanisis (a syndrome of psychic blankness) is a significant contribution. Among his publications, particularly important are "The Theory of Symbolism" (1948c) and "The Early Development of Female Sexuality" (1948a), influenced by Melanie Klein. Jones collected his papers on applied psychoanalysis in *Essays on Applied Psychoanalysis* (1964), which shows the importance he gave to this area of research in psychoanalysis. One should also remember his work *On the Nightmare* (1910) and his classic psychoanalytic interpretation of Hamlet: *Oedipus and Hamlet* (1949). For decades his biography of Freud (1953–1957) has been considered the standard biography of Freud's life.

RICCARDO STEINER

*Works discussed: Hamlet and Oedipus; Sigmund Freud: Life and Work.*

*Notion developed: Aphanisis*

*See also: American Psychoanalytic Association; Boundary violations; British Psycho-Analytical Society; Canada; Controversial Discussions; Erythrophobia; Eroticism, anal; Feminism and psychoanalysis; First World War: The effect on the development of psychoanalysis; Functional phenomenon; Great Britain; International Journal of Psychoanalysis, The; International Psychoanalytical Association; Lay analysis; Nightmare; Phallic mother; Psychoanalytic Review, The; Psychotherapy; Rationalization; Scopophilia/scopophilia; Secret Committee; Shakespeare and psychoanalysis; Standard Edition of the Complete Psychological Works of Sigmund Freud; Symbol; Symbolism; Tavistock Clinic.*

### **Bibliography**

- Brome, Vincent. (1982). *Ernest Jones: Freud's alter ego*. London: Caliban Books.
- Jones, Ernest. (1910). *On the nightmare*. London: Hogarth Press and the Institute of Psycho-Analysis, 1931.
- . (1948a). Early development of female sexuality. In his *Papers on psycho-analysis* (5th ed.). London: Baillière, Tindall, and Cox. (Original work published 1927.)
- . (1948b). *Papers on psycho-analysis* (5th ed.). London: Baillière, Tindall, and Cox.



- . (1948c). The theory of symbolism. In his *Papers on psycho-analysis* (5th ed.). London: Baillière, Tindall, and Cox. (Original work published 1916.)
- . (1949). *Hamlet and Oedipus*. London: Hogarth.
- . (1953–1957). *Sigmund Freud: Life and work* (3 vols.). London: Hogarth.
- . (1959). *Free associations: memories of a psychoanalyst*. London: Hogarth.
- . (1964). *Essays in applied psycho-analysis*. New York: International Universities Press.
- Lacan, Jacques. (1959). Á la mémoire d'Ernest Jones: sur la théorie du symbolisme. *Psychanalyse*, 5, 2–20.
- Mijolla, Alain de. (1998). Freud, biography, his autobiography and his biographers. *Psychoanalysis and History*, 1 (1), 4–27.
- Segal, Hanna. (1957). Notes on symbol formation. *International Journal of Psycho-analysis*, 38, 391–397.
- Steiner, Riccardo. (1993). Introduction. In R. Andrew Pascauskas (Ed.), *The complete correspondence of Sigmund Freud and Ernest Jones* (pp. 21–49). Cambridge, MA: Harvard University Press.

## JOUISSANCE (LACAN)

In his seminar of 1959–1960 *The Ethics of Psychoanalysis* (1992), Lacan developed the concept of jouissance (enjoyment) while discussing *Civilization and Its Discontents* (Freud, 1930). In that work, Freud had articulated a contradiction inherent in the concept of pleasure: “This endeavor [of striving for happiness] has two sides. . . . It aims, on the one hand, at an absence of pain and unpleasure, and, on the other, at the experiencing of strong feelings of pleasure. . . . The task of avoiding suffering pushes that of obtaining pleasure into the background” (1930, pp. 76–77).

For Lacan, these two aspects of pleasure were irreconcilable, and he argued that Freud connected the pleasure and reality principles under a no-displeasure principle. This is the very principle that blocks the path to jouissance. “Who is there who in the name of pleasure doesn’t start to weaken when the first half-serious is taken step toward jouissance?” asked Lacan (1959-1960/1992, p. 185). Even an animal, he added, “has an economy: it acts so as to produce the very least possible jouissance. That’s what we call the pleasure principle” (1969-70/1991, p. 88).

It is true that once we start down the path of jouissance, we do not know where it will lead: “It starts with

a tickle and ends up bursting into flames” (Lacan, 1991, p. 83). In *Beyond the Pleasure Principle*, Freud had already noted that “the most painful experiences . . . can yet be felt . . . as highly enjoyable” (1920, p. 17). On the basis of this text, Lacan made a connection between jouissance and repetition. He drew support for his argument from the hysterical symptom of repetition, as in the case of Elizabeth von R., and defined repetition as a trace, a kind of writing, that commemorates “an irruption of jouissance” (1991, p. 89). Jouissance (*Genuss*) is involved when the pleasure principle yields not necessarily to pain, but to unpleasure. The term was already present in Freud, but Lacan developed it as a concept. Still, he complained of never having had the time to outline its parameters, which he would have likely called “the Lacanian field” (1991, p. 93).

In *The Ethics of Psychoanalysis* (1992), Lacan emphasized that Freud posed the question of jouissance in terms of drive. The energy of the superego derives from the libido of this unsatisfied drive; the more the subject fails to feel jouissance, the more libido there is to feed the superego, and the more the superego will demand new renunciations. Lacan believed that in *Civilization and Its Discontents*, Freud was stating that “everything that is transferred from jouissance to prohibition gives rise to the increasing strengthening of prohibition” (Lacan, 1992, p. 176). Thus the guilt triggered by masturbation can be understood as an increase of libido in the superego, brought about by a short circuit in masturbation that achieves only a brief and stifled satisfaction instead of jouissance.

What is involved here is not the satisfaction of need, but of the drive. In fact, Lacan placed the two in radical opposition to one another: “And if the social bond is established by renouncing the satisfaction of the drive, it is because this satisfaction implies the enjoyment—in the juridical sense of the term—of objects that could either belong to others or deprive them of their jouissance.” This situates jouissance in another field and simultaneously introduces the question of religion, moral precepts, and the law.

In *The Ethics of Psychoanalysis* (1992), Lacan based jouissance on the law. If jouissance consists in breaking the barrier of the pleasure principle, if it can only be attained through a transgression, then only a prohibition opens the path toward it. As for the “other,” he is already implicated in Freud’s analysis of sadism: when we inflict pain on others, “we enjoy by identifying with the suffering object.” From his reading of *Civilization*

and *Its Discontents*, Lacan concluded, “Jouissance is evil . . . because it involves suffering for my neighbor” (1992, p. 184). Moreover, he noted that love of one’s neighbor seemed absurd to Freud. Each time that this Christian ideal is stated, “we see evoked the presence of that fundamental evil which dwells within this neighbor. But if that is the case, then it also dwells within me. And what is more of a neighbor to me than this heart within which is that of my jouissance and which I don’t dare go near?” (Lacan, 1992, p. 186).

In “The Subversion of the Subject and the Dialectic of Desire” (2002), Lacan inscribed jouissance in the topography of his graph of desire. At the upper level of the graph, jouissance is indicated by signifying lack in the Other,  $S(\bar{A})$ . This is phallic jouissance, which is related to castration as lack. Traditionally, the erectile organ, the phallus, represents the object of jouissance, not so much by itself, but rather as the missing portion of a desired image. Phallic jouissance is inscribed in the diagram at the level of a vector that starts out from  $S(\bar{A})$ , the Other’s lack, and goes toward  $(\S \diamond D)$ , the drive as articulated by the subject and the demand of the Other. Thus jouissance is “of the Other” and at the same time operates on the level of the drive. Recognizing the Other’s lack produces a fantasy in the subject’s unconscious. In this fantasy, the object represents what the subject imagines that the Other is deprived of.

In everyday life, the mother, as primordial Other, is prohibited from making up for her lack with her child. Thus the Other remains prohibited. In his diagram, Lacan located jouissance at the place of the barred Other,  $S(\bar{A})$  this is also where Lacan inscribed the superego that orders the subject to enjoy, “Jouis!” To this command, the subject can only respond, “Jouis!” (“I hear!”), for such jouissance is structurally prohibited. Lacan repeated that while the superego prohibits and punishes, it also requires that the subject experience jouissance. For Lacan, the requirement to enjoy is directly related to a taboo. But what is prohibited, what must remain unsatisfied, is only the subject’s jouissance. Giving the Other an experience of jouissance does not seem to be prohibited.

The Other is barred in the diagram only by being marked by the loss of object  $a$ . Thus if a subject assumes the position of the Other’s missing object and if this can make the Other whole, then “It would enjoy,” as Lacan said (2002, p. 311). He thus introduced a jouissance outside the phallic order, a mystic jouissance, which he defined as a nonphallic, feminine

jouissance (1998). For being not whole, a woman “has a supplementary jouissance compared to what the phallic function designates by way of jouissance. . . . Y]ou need but go to Rome and see the statue by [Gianlorenzo] Bernini [the Ecstasy of St. Teresa] to immediately understand that she’s coming. There’s no doubt about it” (1998, pp. 73, 76).

But what did Lacan mean when he said that a woman, for being “not whole,” was capable of a supplementary, nonphallic jouissance? With the “formulas of sexuation,” he proposed dividing subjects not according to their biological sex, but according to their relation to the phallus. On the masculine side would be those subjects who take object  $a$  as the cause of their desire and depend upon their phallic nature to attain it. Subjects on the feminine side have one eye on the phallus and one eye on the jouissance of the Other,  $S(\bar{A})$ . The male or female mystic—a designation independent of biological sex—is situated on the feminine side. Supplementary jouissance, strictly speaking, is feminine. But to attain it, the subject must stop looking both ways—toward phallic jouissance and jouissance of the Other—and become devoted only to the latter. Such an experience was attained by St. John of the Cross, for example, who was familiar with a mystical jouissance “outside sex,” and thus beyond the mark of difference and beyond lack. The moment of ecstasy arrives when the mystic, entirely desubjectified and merged with object  $a$  of the Other’s desire, becomes one with the Other, who in turn no longer lacks. The result is that to represent the Other’s jouissance, “ $\bar{A}$ ” is rewritten as unbarred,  $S(A)$ . In *Civilization and Its Discontents*, Freud referred to the “oceanic feeling” of being at one with the greater Whole. Such is the feeling of mysticism, and also of trances and ecstasy.

Whereas Freud discussed the dark relationship between mysticism and suffering with great hesitation, Lacan spoke of them more positively by remarking that on the cultural level, adoration of Christ suffering on the cross naturally sustains jouissance. If certain mystics directly experience jouissance by looking at the Other’s face—by looking at the face of God—others can attain it only by allowing the ever so broken body of Christ on Calvary to sustain it. They partake of a vicarious jouissance from Christ’s mutilated body offered up to God. Commenting on Catholicism, Lacan wrote, “That doctrine speaks only of the incarnation of God in a body, and assumes that the passion

suffered in that person constituted another person's jouissance" (1998, p. 113)

MARIE-CHRISTINE LAZNIK

*See also:* Autism; Castration of the subject; Dark continent; Fantasy, formula of; Fetishism; Graph of Desire; "Heredity and the Aetiology of the Neuroses"; Kantianism and psychoanalysis; Masochism; Matheme; Narcissistic elation; Object *a*; Phallus; Phobias in children; Repetition compulsion; Sexuation, formulas of; Subject's desire; Subject of the drive; Suffering; Symptom; Symptom/sinthome; Voyeurism.

### **Bibliography**

- Freud, Sigmund. (1920). Beyond the pleasure principle. *SE*, 18: 1–64.
- . (1930). Civilization and its discontents. *SE*, 21: 57–145.
- Lacan, Jacques. (1991). *Le séminaire*. Book 17: *L'envers de la psychanalyse (1969–1970)*. Paris: Seuil.
- . (1992). *The seminar of Jacques Lacan*. Book 7: *The ethics of psychoanalysis (1959–1960)* (Dennis Porter, Trans.). New York: W. W. Norton.
- . (1998). *The seminar of Jacques Lacan*. Book 20: *On feminine sexuality: the limits of love and knowledge, encore (1972–1973)* (Bruce Fink, Trans.). New York: W. W. Norton.
- . (2002). The subversion of the subject and the dialectic of desire in the Freudian unconscious. In his *Écrits: A selection* (Bruce Fink, Trans.). New York: W. W. Norton. (Original work published 1960.)

---

## **JOURNAL DE LA PSYCHANALYSE DE L'ENFANT**

In 1979, the initial idea that brought together several psychoanalysts from the Association psychanalytique de France—among them Pierre and Claudine Geissmann, Pierre Ferrari, Didier Houzel, and Annie Anzieu—was the need to exchange and develop ideas together. They were all convinced of the originality of practicing with children and its obvious role in psychoanalysis. A few years later, in 1986, new developments in their thinking and a desire to leave a trace of the work they had done, coupled with the absence in the French press of a specifically suitable publication, led the group to constitute an editorial committee and to create the *Journal de la psychanalyse d'enfants*

(Journal of child psychoanalysis), which has been published ever since by Bayard Presse.

The idea of the *Journal*, a sort of forum for writing that sheds light on a given theme from various different angles, leaves readers the freedom to make their own choices and to use or disregard editorial suggestions. Reading notes usually deal with the issues of the day. A network of French and foreign correspondents has been established — Robin Anderson (London), Yolanda Gampel (Tel Aviv), David Rosenfeld (Buenos Aires), Jochen Stork (Munich) — to guarantee the diversity of currents of thought and the people presenting them. In addition, contributors have included Otto Kernberg in America, Suzanne Maiello in Italy, Kleinian and post-Kleinian authors, Hanna Segal, the Tavistock Clinic, Frances Tustin, and, in France, Didier Anzieu, Serge Lebovici, and Geneviève Haag, to mention but a few.

Given the fact that it appears twice yearly, the subjects selected by the editorial committee are announced long enough in advance to enable everyone to make personal contributions and prospective authors to do the work required. Evaluation of submitted texts takes account of their formal qualities but most of all the relationship between theory and clinical practice as revealed in the vicissitudes of the transference.

As chief editor, Pierre Geissmann did most of the coordinating, liaising, and translating until November 1995. His loss is deeply felt, but his dynamism and rigor continue to be a model for the editorial committee and for Claudine Geissmann and Didier Houzel, who have replaced him.

JEAN-CLAUDE GUILLAUME

*See also:* France; Child psychoanalysis.

---

## **JOURNAL D'UN MÉDECIN MALADE**

Faced with the worsening of his illness and thus progressive weakness that made all activity difficult, René Allendy's friends and family conceived the idea of a diary as a way of channeling his mental energies. The *Journal d'un médecin malade* describes the coming and going of indifferent visitors in the small room to which he was restricted during his illness. As Allendy, a doctor and psychoanalyst, hovered between life and death, the diary lucidly describes his attempt to make

sense of his fate and heal himself. Throughout the book he describes the various stages of illness, and provides a reassessment of his life.

MARGUERITE FRÉMONT

See also: Allendy, René Félix Eugène; Autobiography.

### Source Citation

Allendy, René. (1944). *Journal d'un médecin malade ou Six mois de lutte contre la mort*. Paris: Denoël.

### Bibliography

Allendy, René. (1932). Various instincts and their development. *Psychoanalytic Review*, 19 (3), 310–318.

———. A case of eczema. (1932). *Psychoanalytic Review*, 19 (2), 152–163.

———. (1932). The mechanism of auto-punishment. *Psychoanalytic Review*, 19 (1), 72–76.

———. (1933). Sadism in woman. *Psychoanalytic Review*, 20, 4: 437–439.

Frémont, Marguerite. (1994). *La Vie du Dr René Allendy (1889–1942)*. Montpellier: Climats.

## JOURNAL OF THE AMERICAN PSYCHOANALYTIC ASSOCIATION

*The Journal of the American Psychoanalytic Association*, JAPA, although not the oldest psychoanalytic journal in the United States (the *Psychoanalytic Review* dates from 1911), is the most widely read with over 6,000 subscribers in the United States and abroad. It was inaugurated in 1953, incorporating the *Bulletin of the American Psychoanalytic Association*. Its mission was articulated by Robert P. Knight, then the Association's president: "... to select the best contributions to psychoanalysis the Editor and Editorial Board can find among submitted and solicited articles."

JAPA was founded in 1953 as the official organ of the American Psychoanalytic Association, its mission to publish scholarly articles on psychoanalytic theory, clinical practice, research, and history. The Association was very much aided in the enterprise by Dr. Abraham Kagan, then president of International Universities Press, which became the publisher of the *Journal*.

The first editor was John Frosch who served for 20 years with the assistance of Nathaniel Ross, who served as book editor. He was succeeded by Harold Blum,

(editor, 1974–1983) and Theodore Shapiro (editor, 1984–1993). Arnold Richards, began his tenure in 1994 and served until 2003. The editor in 2004 was Steven J. Levy.

From its inception JAPA was the venue of choice for many of the most important contributors to the psychoanalytic literature. Issues in those early years included papers by Phyllis Greenacre, Charles Fisher, Kurt Eissler, Margaret Mahler, Bertram Lewin, Robert Waelder, Lawrence Kubie, Annie Reich, and Ralph Greenson. In the 1960s the *Journal* sponsored four monographs: *Ego Psychology and the Object World* by Edith Jacobson; *Psychoanalytic Concepts and the Structural Theory* by Jacob Arlow and Charles Brenner, and *The Id and the Regulatory Principles of Mental Functioning* by Max Schur. Special supplements issued during the terms of Harold Blum and Theodore Shapiro focused on female psychology (1976), psychoanalytic technique and theory of therapy (1979), defense and resistance (1983), books in review (1985), the concept of structure in psychoanalysis (1988), affect (1991), and psychoanalytic research (1993). A second supplement on female psychology, edited by Arnold Richards and Phyllis Tyson, was published in 1996.

The *Journal* publishes approximately 40 scholarly articles and 40 book reviews each year. JAPA has the right of refusal of all papers presented at the Fall and Midwinter meetings of the American Psychoanalytic Association and publishes summaries of each meeting's scientific panels. Several new formats have been introduced recently, including commentaries on plenary presentations and target papers. Although the majority of JAPA contributions are concerned with clinical theory and practice, the *Journal* also publishes papers on applied analysis, historical subjects, and empirical research. Papers are selected based on the quality of writing, scholarship, and research rather than on theoretical orientation. Since 1974 JAPA has awarded a prize endowed the Mark and Aiva Kanzer Fund to one or two of the best papers published during the year. In 1997, The Analytic Press succeeded International Universities Press as the distributor and marketer of the *Journal*.

New members of the editorial board of the *Journal* are nominated by the editorial board itself and elected by the Executive Council of the APsA. Board members are the "peers" of the "peer review" selection process. Although JAPA is the official journal of the American Psychoanalytic Association, members of the

editorial board need not be members of the Association, and outside reviewers are frequently called on for their expertise in specific areas. As of 2004, the book review editors were Rosemary H. Balsam and Paul Schwaber. They were preceded by Glen Gabbard, who succeeded Otto Kernberg, who in turn took over from Nathaniel Ross.

ARNOLD D. RICHARDS

See also: American Psychoanalytic Association; United States.

## JOUVE, PIERRE JEAN (1887–1976)

Pierre Jean Jouve, a French writer and poet, was born on October 11, 1887, and died in Paris on January 8, 1976. He is important for incorporating psychoanalytic themes in his novels. His father, Alfred, was a manager in a life insurance company; his mother, Eugénie Aimée Rosé, encouraged his interest in music. A sister, Madeleine, born in 1889, married Pierre Castiau, who had considerable influence on the poet's intellectual development.

In 1902 Jouve had an appendectomy, followed by years of fatigue and depression. In 1905 he received his baccalaureate, then went on to study law at the University of Lille. At school he published a poetry review, *Les bandeaux d'or*. In 1910 he married Marie Caroline Charpentier, a history major, who monitored his uncertain health. They had a son, Olivier, in 1914.

Disqualified from active service, he served as a nurse during the First World War and struck up friendships with Romain Rolland and other pacifists. In 1921 he met Blanche Reverchon. A marital crisis ensued, followed by divorce, and in 1923 Jouve moved in with Blanche to her apartment on Rue Boissonnade in Paris. In 1933 they moved to Rue Tournon.

In 1925 Jouve published *Paulina 1880*, a novel about the author and Hélène, a composite of several women. In 1928 he published *Hécate*, and in 1931 *Vagadu*, a sequel. Together, these two works make up the *Aventures de Catherine Crachat*. In a commentary on *Vagadu*, Jouve confirmed that he had read a description of the principal steps in psychoanalytic therapy after writing *Hécate*. He then began a fictional analysis of Catherine Crachat, which became the novel *Vagadu*.

In his writing, Jouve focused on three elements of Freudian theory: there is always an unconscious; it is dominated by sexual energy and its opposite, the death impulse; the development of an unconscious sex life is accompanied by feelings of guilt and human error. Jouve created a body of work divided between the Saint Paul of the Epistle to the Romans and Freud, religious chastity and the sexual instinct, in which the soul, driven by love, contains death. The erotic writings of this period were published only after his death.

In 1933 he wrote, with Blanche, an article for the *Nouvelle revue française* titled “Moments d'une psychanalyse” (Moments of a psychoanalysis). The same year he also wrote *Sueur de sang* (Sweat of blood), a collection of poems written on the basis of unconscious values.

During the 1940s he was close to the Gaullist movement and the Resistance. He stopped writing in 1962 and died on the exact same day as Blanche two years later.

JEAN-PIERRE BOURGERON

See also: France; Literature and psychoanalysis; Reverchon-Jouve, Blanche.

### Bibliography

- Jouve, Pierre Jean. (1933). *Sueur de sang*. Paris: Cahiers libres.
- . (1973). *Paulina 1880* (Rosette Letellier and Robert Bullen, Trans.). Indianapolis: Bobbs-Merrill. (Original work published 1925.)
- . (1997a). *Hécate* (Lydia Davis, Trans.). Evanston, IL: Marlboro press/Northwestern. (Original work published 1928.)
- . (1997b). *Vagadu* (Lydia Davis, Trans.). Evanston, IL: Marlboro Press. (Original work published 1931.)
- Reverchon-Jouve, Blanche, and Jouve, Pierre Jean. (1933, March 1). Moments d'une psychanalyse. *Nouvelle Revue Française (N.R.F.)*, 234, 353–385.

## JUDAISM AND PSYCHOANALYSIS

Judaism, a monotheistic religion, and Jewish identity, a subjective culture and experience, are part and parcel of the history of psychoanalysis. Sigmund Freud was

born on May 6, 1856, in Freiberg. His father, Jakob Freud, still mourning the death of his own father, Rabbi Schlomo, gave his son the Jewish name Schlomo and the Christian name Sigmund, later changed to Sigismund for a short time. Freud was partly reared by a catholic nanny, Monica Zadjic. He experienced his first exile at the age of three, when the family left Moravia for Vienna. Jakob taught him to read the family Bible, which he continued to read in Jewish primary school and later in the gymnasium. Freud continued to see his Hebrew teacher, Samuel Hammerschlag, until the latter's death.

Unlike the family of his wife, Martha, Freud's family neglected religious practices but respected traditions, particularly the principal holidays of Jewish life. Freud was circumcised on May 13, 1866. When he was thirty-five years old, his father gave him Philippson's bilingual illustrated Bible, with a dedication in Hebrew. Théo Pfrimmer (1982) noted more than four hundred Biblical quotations in Freud's works. Freud's Jewish identity never waned: between 1897 and 1907 he regularly attended the meetings of B'nai Brith, his first public, and remained connected to the lodge until 1926. In 1929 YIVO (Yiddisher Vissenshaftlikher Institut), an institute devoted to the Yiddish language (which his mother continued to speak throughout her life), invited him to be a member of its presidium, along with Albert Einstein and many others.

An early experience of anti-Semitism confirmed Freud's decision not to court the favor of the "compact majority" (B'nai Brith conference, May 6, 1926). The Nazis condemned his works to the fire, and in May 1933 his books were burned in Berlin. Some members of his family, including four of his five sisters, perished in extermination camps.

Like Franz Kafka, Freud was confronted with the question of his Jewish identity—an affective dimension of Freud better reflected in his correspondence than in his scientific works. Adam, Joseph, Jacob, Moses, like Grandfather Schlomo, the central figure in an "identification fantasy" (Mijolla, 1975), all had their place in the line of filiation, linking fathers and sons, that lies at the heart of the Oedipus complex he elaborated from Greek tragedy.

Caught between different cultures (Germanic, Christian, and the Greco-Roman classical humanities) and different languages (Yiddish, Hebrew, Czech, and German), Freud was confronted with the Viennese cri-

sis of modernity. This same sense of crisis can be seen in the writers of the literary group Jung-Wien, who gave expression to an identity crisis in which the Enlightenment, German Romanticism, and scientific discourse rubbed shoulders. Freud—an atheist, a "Jewish infidel" pretending not to know Hebrew and torn with regard to the Zionist ideal—rejected all notions of conversion, the "entrance ticket to Western society," as Heinrich Heine called it.

"[H]ow comes it that none of the godly ever devised psychoanalysis and that one had to wait for a godless Jew?" Freud wrote to Oskar Pfister on October 9, 1918 (quoted in Grollman, 1965, p. 115). In this question he attributed his discovery, the only one capable of promoting a "new science," to a Jew whose lack of faith contested religion and its taboos. Freud refused to affiliate psychoanalysis with Judaism, while recognizing that it was linked to a special "experience." Along with some of his students (Karl Abraham and Theodor Reik), Freud studied religious phenomena in the light of psychoanalysis, but the so-called "Jewish science" of psychoanalysis was in fact a scientific project. Freud, basing his thesis on aphasia and the *Project for a Scientific Psychology* (1950c [1895]) on neurophysiological data, was struggling to establish the scientific status of his discovery.

Until he met Carl Gustav Jung in 1907, his first disciples were Jews who more or less inherited the de-Judaization commenced by their fathers as they struggled to assimilate. Later, non-Jews joined the Wednesday Psychology Society. The introduction of Jung, son of a pastor and assistant to Professor Eugen Bleuler in Zurich, had a twofold aim: one political, to spread psychoanalysis beyond the confines of Judaism; the other scientific, to guarantee Freud a university audience. In his correspondence with Romain Rolland (1923–1936), Freud gave the "mystic element" that Jews "lack" (letter to Karl Abraham, July 20, 1908) and the "oceanic feeling" a predominant position.

In London in 1938, his twilight year and his second exile, Freud completed his work on Moses with difficulty, scruples, and pain. In *Moses and Monotheism* (1939a [1934–38]), Freud questioned the "enigmas" surrounding Moses' place and role in history and the survival of the Jewish people, the special target of centuries-old anti-Semitic hatred. When most psychoanalysts were forced by Nazi persecutions to leave Germany and Austria, Freud compared the dissolution of the psychoanalytic societies to the destruction of the

Temple by quoting Rabbi Johanan Ben Zakkai on the occasion of the opening of the Yavneh school: “The invisible temple of Judaism could not be built until the visible Temple had been destroyed.” Anna Freud spoke of the “new diaspora” in a letter to Ernest Jones dated March 8, 1934. She used the expression again in Jerusalem in 1977.

Freud rejected the Jewish religion while being faithful to his Jewish identity by recognizing its contribution to certain aspects of psychoanalysis. On May 11, 1908, Freud, for whom Judaism was part of his racial heritage, commented to Karl Abraham, “The Talmudic way of thinking cannot disappear in us just like that.” In fact, both Judaism and psychoanalysis teach the central importance of language and its effects.

Since the terror of the Holocaust, many researchers have dealt with the conflicted affinity between Judaism and psychoanalysis. Contemporary psychoanalysts Gérard Haddad, Eliane Amado Lévi-Valensi, and Jacquy Chémouni have studied the Talmudic sources of psychoanalysis (thirty years after David Bakan’s 1958 book on Jewish mysticism); equivalences between Jewish and psychoanalytic hermeneutics, particularly in relation to dreams; the ambiguous relations among Freud, Judaism, and psychoanalysis; and “secularized messianism,” going from the particular to the universal.

Historians have focused their investigations on Freud’s relationship with his father (Marthe Robert, Marianne Krull); on Freud’s creativity as it relates to his atheism (Peter Gay); and on the traces of Judaism at work in Freud’s *Moses* essays (1939) (Yosef Hayim Yerushalmi). For Yerushalmi, who refers to psychoanalysis as the “Jewish science,” psychoanalysis is the last avatar of Judaism, a “Judaism without a God.”

Showing the relations between psychoanalysis (the unconscious and its laws) and the subjective essence of Jewish culture does not preclude granting psychoanalysis a scientific, and therefore universal, status. Indeed, the teaching and transmission of psychoanalysis reveals a special tension between the particular and the universal in the field. Perhaps Judaism reveals “the hidden truth of psychoanalysis” (Jacques Ascher and Daniel Weiss).

JACQUES ASCHER AND PÉREL WILGOWICZ

See also: Ethics; Israel; *Moses and Monotheism*; Phillipson Bible; Racism, anti-Semitism, and psychoanalysis; *Sex and Character*; Zweig, Arnold.

## Bibliography

- Ascher, Jacques, and Weiss, Daniel. (1997). De l’un à l’autre. La psychanalyse est-elle une histoire gay? *Revue Internationale de psychanalyse*, 6, 109–124.
- Bakan, David. (1958). *Sigmund Freud and the Jewish mystical tradition*. Princeton, NJ: Van Nostrand.
- Chemouni, Jacquy. (1991). *Freud, la psychanalyse et le judaïsme*. Paris: Éditions universitaires.
- Freud, Sigmund. (1939). Moses and monotheism: three essays. *SE*, 23: 1–137.
- . (1950c [1895]). *Project for a scientific psychology*. *SE*, 1: 281–387.
- Gay, Peter. (1987). *A Godless Jew: Freud, atheism, and the making of psychoanalysis*. New Haven, CT: Yale University Press.
- Grollman, Earl A. (1965). *Judaism in Sigmund Freud’s World*. New York: Appleton Century.
- Mijolla, Alain de. (1975). Fantômes d’identification: Jakob, Freud et Goethe. *Études freudiennes*, 9–10, 167–210.
- Mijolla, Alain de. (1987). Unconscious identification fantasies and family prehistory. *International Journal of Psychoanalysis*, 68, 397–403.
- Pfrimmer, Théo. (1982). *Freud, lecteur de la Bible*. Paris: Presses Universitaires de France.
- Robert, Marthe. (1976). *From Oedipus to Moses: Freud’s Jewish identity* (Ralph Manheim, Trans.). Garden City, NY: Anchor Books. (Original work published 1974.)
- Yerushalmi, Yosef Hayim. (1991a). *Freud’s Moses: Judaism terminable and interminable*. New Haven, CT: Yale University Press.
- . (1991b). *The purloined Kiddush cups: reopening the case on Freud’s Jewish heritage*. Binghamton: State University of New York.

## JUDGMENT OF CONDEMNATION

Condemning judgment is one of the possible vicissitudes of a repressed instinctual impulse. It is in fact the most highly elaborated one, since it involves neither flight nor a refusal to give access to the intruding element, but, on the contrary, since it is a judgment, acknowledging the existence of the impulse that will later be condemned.

Sigmund Freud raised the issue of condemning judgments in “Five Lectures on Psycho-Analysis” (1910a [1909], p. 53) in the context of a crucial question: If psychoanalysis makes possible the lifting of repression, what happens to the instincts that are liberated in the process? Freud’s response is nuanced and consists in emphasizing that other, more conventional

instinctual impulses may also have been liberated and can oppose the former. But above all, repression is posited as the result of the time lag between the capacities of the immature ego and its instincts. The work of analysis, in contrast, can lead to an appropriate application of these instincts. What, then, is the role of the condemning judgment? If we wish to see it not just as the conscious form of the operation of repression, we need to emphasize its adjudicatory aspect, which involves a presentation of conflicting elements and a decision—a negative one, in this case. Condemning judgments reproduce on the ethical level what judgments in general effect on the intellectual level. As Freud wrote in “Formulations on the Two Principles of Mental Functioning” (1911b): “The place of repression, which excluded from cathexis as productive of unpleasure some of the emerging ideas, was taken by an *impartial passing of judgment*, which had to decide whether a given idea was true or false—that is, whether it was in agreement with reality or not—the decision being determined by making a comparison with the memory-traces of reality” (p. 221).

In the case of reality judgments, as with condemning judgments, it is the pleasure principle that sits in the dock. It is conceivable, however, that the results of analysis may be viewed differently in the case of a child as opposed to an adult. We saw earlier that a condemning judgment was one of the possible outcomes for impulses repressed long ago. On the other hand, Freud was far more categorical in the case of “Little Hans,” related in “Analysis of a Phobia in a Five-Year-Old Boy” (1909b), precisely because the child’s maturation was not sufficient to enable him to go beyond what he must condemn. “For analysis,” wrote Freud in this essay, “does not undo the *effects* of repression. The instincts which were formerly suppressed remain suppressed; but the same effect is produced in a different way. Analysis replaces the process of repression, which is an automatic and excessive one, by a temperate and purposeful control on the part of the highest agencies of the mind” (p. 145).

It can be imagined here that condemnation by the child is closely dependent upon condemnation by the adult, in the form of upbringing. The condemning judgment liberates the condemned person in that it limits the fault by specifying its nature. Repression, by contrast, paralyzes psychic and intellectual life because it constitutes a violent action that will be opposed by another action, in the form of the return of the

repressed and symptom formation. Freud’s humanistic attitude to judgment and its liberating role, which is far from being unique, is evident here in this reference.

SOPHIE DE MIJOLLA-MELLOR

*See also:* Ethics; Law and psychoanalysis; Repression.

### **Bibliography**

- Freud, Sigmund. (1909b). Analysis of a phobia in a five-year-old boy. *SE*, 10: 1–149.
- . (1910a [1909]). Five lectures on psycho-analysis. *SE*, 11: 7–55.
- . (1911b). Formulations on the two principles of mental functioning. *SE*, 12: 213–226.
- . (1925h). Negation. *SE*, 19: 233–239.

---

## **JUNG, CARL GUSTAV (1875–1961)**

A Swiss physician and psychiatrist, Carl Gustav Jung, founder of analytical psychology, was born on July 26, 1875, in a little village on the shores of Lake Constanz on the Swiss-German border. He died on June 6, 1961, in Kussnacht, Switzerland.

Jung’s father was a rural Protestant minister. When Jung was one year old, the family moved to a rural village just outside Basel, where Jung spent the remainder of his childhood. A sister was born when Jung was nine.

When Jung was three his mother became depressed and was unavailable for several months. Jung always felt much closer to his mother than to his father. He experienced his father as having lost the faith, whereas he experienced his mother as having a deeply intuitive and religious nature.

He entered the University of Basel in 1895 to study medicine, and completed his medical studies in the winter of 1900. He then began his psychiatric studies at the Burghölzli Clinic under the direction of Eugen Bleuler. His father died in 1896. His medical school thesis, *The Psychology of So-Called Occult Phenomena*, a study of spiritualistic seances of his cousin, was published in 1902. That same year, he spent several months in Paris as a student of Pierre Janet.

Jung began his scientific work with word-association experiments while at the Burghölzli Clinic. He discovered consistent patterns of expression and inhibition when select words were given to a subject who



was instructed to react with the first word that came to mind. Jung coined the term “complex” for the cluster of images and emotion revealed when he inquired closely about the subject’s experience of inhibition. He interpreted the results using Freud’s theory of repression. In 1906 Jung broadened his studies to include patients at the Burghölzli, out of which experience came his classic monograph on *The Psychology of Dementia Praecox*.

In 1903 he married Emma Rauschenbach, the daughter of a prominent family in Schaffhausen. They had five children, four daughters and one son. Jung relied on her strong character and native intelligence, and later on she became an analyst in her own right. He remained at the Burghölzli until 1909, when he opened a private practice in the village of Küssnacht just outside Zurich where he remained for the rest of his life.

The work on complexes led to a correspondence with Freud and then to a meeting in 1907. The next six years saw their intense friendship and professional collaboration. Jung became the “crown prince,” the first president of the International Psychoanalytical Association, editor of the *Jahrbuch*, and a defender of psychoanalysis. They traveled to Clark University in Massachusetts together in 1909, analyzing each other’s dreams on the long ocean voyage. But, as Jung began to delve into mythology, a divergence on the meaning of libido became a central point of conflict between the two men. Jung defined libido as meaning interest in general, and believed that all libido cannot be reduced to sexuality, other instincts such as hunger and culture having equal value. In 1911 Jung published the first half of his work *A Study of the Transformations and Symbolisms of the Libido* in the *Jahrbuch*. The second half came out in 1913. Here Jung focused on incest in terms of the mother-son pattern, and the need for the son to be delivered from the power of the maternal unconscious. By this time the relationship between Freud and Jung had become so strained that Freud urged Jung to leave the psychoanalytic fold,

From 1913 until 1918 Jung withdrew into a period of intense self-analysis, resigning his position at the University of Zurich. He called this his “confrontation with the unconscious.” All his later writings were an assimilation and understanding of his inner experiences during those years.

Jung’s first major work of his post-Freudian phase was *Psychological Types*, in which he formulated the

concepts of introversion and extroversion, along with the function types: sensation, thinking, feeling, and intuition. For Jung this work continued his struggle for identity in relationship to Freud and Adler. Also, in the appendix he defined all the concepts for which his work would become most famous; collective unconscious, archetypes, individuation, dreams, psychic energy, etc. Furthermore, during this period he explicated his notions of psychotherapy as a dialectic between therapist and patient, who are equal partners in the psychological transformation.

As his fame spread he began to receive analysands from many parts of the world. He also traveled widely, to the American Southwest, North Africa, Central Africa, and India. He received honorary doctorates from many institutions, including Harvard and Oxford Universities.

Jung’s most controversial episode occurred in 1933. He replaced Ernst Kretschmer as president of the German Society of Psychotherapy and immediately made it into an International Society, so that Jewish members could retain membership. He remained president until 1940, which meant he had to work closely with the Nazis. Some of his statements during this period have been construed as anti-Semitic, and those who have wished to discredit his work seized upon them as a pretext for their dismissal. This issue has surfaced periodically for the past fifty years, but there is no definitive evidence that Jung ever was a Nazi sympathizer.

On the other hand, we do know that he warned repeatedly against the dangers of mass movements, and that in 1936 he published *Wotan*, an uncompromising analysis of the psychological, and specifically archetypal, reasons for Nazism and of the risks it represented for the individual.

In 1944 Jung had a massive, nearly fatal heart attack. He describes his visions during the attack in *Memories, Dreams, and Reflections* (1962/1966). His recovery was complete, but he retired from practice, continuing his research into alchemical studies, and writing two important books, *The Psychology of the Transference* and *Mysterium Coniunctionis*. Jung had become interested in alchemy in 1928 when a good friend, Richard Wilhelm, introduced him to the Chinese alchemical text, *The Secret of the Golden Flower*. Noting the similarities between alchemy and the unconscious patterns he observed in his analysands, he saw alchemy as the missing link between the mythology of the pre-Christian psyche and modern dreams.

Jung valued his introversion greatly, and beginning in 1923 he built a tower in Bollingen, where he would spend solitary weeks. He died after a brief illness on June 6, 1961, in the house in which he had lived since 1908.

THOMAS KIRSCH

*Works discussed:* *Psychology of Dementia præcox; Psychology of the Unconscious, The.*

*See also:* Allgemeine Ärztliche Gesellschaft für Psychotherapie; Analytical psychology; “Autobiographical Study, An”; Belief; Bleuler, Paul Eugen; Burghölzli asylum; Clark University; Complex; Cryptomnesia; Deferred action; *Delusions and Dreams in Jensen’s “Gradiva”*; Ego-libido/object-libido; First World War: The effect on the development of psychoanalysis; Free association; “From the History of an Infantile Neurosis” (Wolf Man); Great Britain; Gross, Otto Hans Adolf; Hirschfeld, Elfriede, Imago; International Psychoanalytical Association; *Jahrbuch der Psychoanalyse*; Libido; Mother goddess. Midlife crisis; Mysticism; “On Narcissism: An Introduction”; “On the History of the Psychoanalytic Movement”; Primal scene; *Psychoanalysis of Fire, The*; “Psycho-Analytic Notes on an Autobiographical Account of a Case of Paranoia (Dementia Paranoides)”; Religion and psychoanalysis; Schizophrenia; Self-consciousness; Spielrein, Sabina; Splits in psychoanalysis; Switzerland (German-speaking); Symbolization, process of; Telepathy; *Totem and Taboo*.

### **Bibliography**

Jung, Carl Gustav. (1916). The structure of the unconscious. *Coll. Works* (Vol. 7). London: Routledge & Kegan Paul.

———. (1966). *Memories, dreams, reflections*. London: Routledge. (Original work published at 1962)

McGuire William. (1974) *The Freud-Jung letters: The correspondence between Sigmund Freud and C.G. Jung*. Princeton, NJ: Princeton University Press.

Wehr, Gerhard. (1987) *Jung*. Boston and London: Shambhala.

### **Further Reading**

Mijolla, Alain de. (1989). Images of Freud: From his correspondence. *International Forum for Psychoanalysis*, 5, 87–110.

---

## **JUNG-RAUSCHENBACH, EMMA (1882–1955)**

Emma Rauschenbach was born on March 30, 1882, in Schaffhausen, Switzerland, and died on November 27,

1955, in Zurich. Analyst and wife of Carl Gustav Jung, she was the first president of the Psychology Club of Zurich (1916–1919) and vice-president of the Carl Gustav Jung Institute of Zurich (1950–1955).

Although her family came from the upper bourgeoisie and her father was a cultured patron of the arts, she did not receive a higher education. At the age of twenty-one, while visiting Berthe Rauschenbach, Jung, an old friend of Emma’s parents, noticed the adolescent Emma. He was so taken by her that he thought, “This is my wife,” as he recounted in his memoirs.

They were married on February 14, 1903, and had five children. Emma was one of the rare wives of pioneers to take an interest in her husband’s intellectual activities and to participate in his research. As was customary in family psychoanalysis at the time, Jung began to analyze her in 1910. In the six letters that Emma addressed to Freud in late 1911, she displays a subtle comprehension of the unconscious. When she intervened in the foreseeable conflict, she fearlessly and with amazing acuity interpreted Freud’s attitude to her husband: “Do we not often give much because we want to keep much?” and she recommended: “Do not think of Carl with a father’s feelings . . . but as one man to another, who like you must accomplish his own law.” She also confided in him the difficulty of being the wife of a man with whom “all women are naturally in love,” while Jung’s relationship with Sabina Spielrein was taking an amorous turn and an indestructible bond with his assistant Toni Wolf was forming. Confronted with her husband’s infidelities and in spite of the suffering they caused her, she used her intelligence and sensitivity to try to understand him; but more so, she used these traits to understand herself as a woman.

She started work as an analyst in 1930 and left a memory of great qualities as a human being. She undertook a long study of the Grail, published after her death by Marie Louise von Franz who, by integrating it into her own work, unfortunately deprived it of its originality. In 1931 she led a conference at the Psychological Club of Zurich on “The Problem of the Animus,” published by Jung in *Wirklichkeit der Seele* (Reality of the Soul) in 1934. In 1950 she wrote an essay on “The Mythical Representations of the Anima,” published in 1955 in the joint work entitled *Studien zur Analytischen Psychologie C. G. Jungs* (Studies for the Analytical Psychology of C. G. Jung). These two essays dealing with the opposing archetypes of psychic sexuation, the feminine “anima” in the

man, and the masculine “animus” in the woman, were brought together a single publication (1957).

The originality of Emma Jung’s writings lies in her woman’s approach to the female psyche, marking a break with the often sexist works of the pioneers of psychoanalysis. Moreover, her thinking always remained close to her experience as an analyst. When she died, Jung declared: “She had an immense influence of unfathomable depth on my life.”

BRIGITTE ALLAIN-DUPRÉ

See also: Animus-Anima (analytical psychology); Jung, Carl Gustav.

### **Bibliography**

- Freud, Sigmund, and Jung, Carl Gustav. (1974). *Sigmund Freud-C. G. Jung, Briefwechsel. (1906–13)* (W. McGuire and W. Sauerländer Eds.). Frankfurt am Main: Fischer.
- Hannah, Barbara. (1976). *Jung, his life and work: A biographical memoir*. New York: Putnam.
- Jung, Carl Gustav. (1966). *Memories, dreams, reflections*. London: Routledge. (Original work published 1962)
- Jung, Emma. (1957). *Animus and anima*. New York : Analytical Psychology Club of New York.
- Jung, Emma, and Franz, Marie Louise von. (1971). *The grail legend*. (Andrea Dykes, Trans.). London: Hodder & Stoughton.

---

## **JURY, PAUL (1878–1953)**

Paul Jury, a French theologian and psychoanalyst, was born on September 20, 1878, in Bergerac (Dordogne) and died in Paris on March 24, 1953. The only son of a family of six children, Jury was a boarding student at the Lycée Michelet in Vanves; to attend school he traveled from Indochina, where his father was an engineer with the railroad. At the age of thirteen he converted to Catholicism and, after receiving his baccalaureate in Pau, joined the Jesuits on November 24, 1896, in Toulouse. Because the Jesuits were unable to work in France, Jury worked in Belgium, where he was ordained a priest in 1909; he became a doctor of theology in 1910.

A man with a penchant for literature, Jury wrote for newspapers and magazines, and in 1923 left the Jesuits, reproaching them for prohibiting research. He moved to Paris and, after undergoing a spiritual crisis, became interested in psychoanalysis. He began an analysis with Charles Odier on July 30, 1932, and contributed to the work of the Paris Psychoanalytic Society. He was active in the organization’s meetings and published several articles of his own as well as translations of Freud in the recently established *Revue française de psychanalyse*.

Between 1940 and 1944 he lived in Grenoble, where a period of intense creative activity ensued. Here and in Paris he wrote several articles, which were collected into a single volume: *Le Jardin de Candide (ou De Dieu à l’homme)*, and several volumes of rationalist exegesis of the New Testament, which he published after he had left the church. Beginning in 1946, he contributed several essays to the review *Psyché*. He continued working as a translator, publishing works by Karl Abraham in the *Revue française de psychanalyse*, and a translation of Freud’s *Inhibitions, Symptoms, and Anxiety* (1926d).

He died at the age of seventy-five, nearly blind, having continued to exercise his priestly functions throughout his life. His books and manuscripts were conserved and published by his student André Michel.

ANDRÉ MICHEL

See also: France.

### **Bibliography**

- Jury, Paul (1950). Descartes, psychanalyste avant la lettre, *Psyché*, 40. (Original work published 1935)
- . (1956), *Journal d’un prêtre*, Paris: Gallimard.
- . (1964), *Les débuts de l’évangile ou les quatre légendes de Jean-Baptiste*. Gentilly: Albin Michel.
- Michel, André. (1987) Léon Bloy et Paul Jury. *Bulletin Sté ét. bloyennes*, 10–11, Oct. 1990, 12–13, April 1993.
- . (1992). *Décroire, fondement d’un rationalisme psychanalytique (entretiens avec Paul Jury)* . Gentilly: Albin Michel.

# K K

## KANTIANISM AND PSYCHOANALYSIS

Both Emmanuel Kant and Arthur Schopenhauer, his disciple and interpreter, had a profound influence on psychoanalysis, although their underlying theories sometimes need to be differentiated. Just as important, however, is the fact that psychoanalysis can be considered an avatar of Kantianism, if not of metaphysics in general.

References to Kant appear in Freud's work in three different contexts:

1. Freud presents Kant's "categorical imperative" as the "inheritor of the Oedipus complex."
2. Freud contested the universal and necessary character of the categories of space and time in human sensibility. These categories undergo a process of development that depends on the relationship between consciousness and the unconscious.
3. Freud compares the unconscious and the thing-in-itself (Assoun, 1976). Although the first reference serves only to legitimate and anticipate Freudian theory, the other two references situate Freud's metapsychological reflections in terms of their differences from Kantian thought. Freud read Kant according to Schopenhauer's interpretation, which ties transcendentalism to anthropology.

Many of Freud's ideas (dreams and repression, the unconscious, sexuality, love, and death) are similar to those of Schopenhauer. Freud recognized a connection to some of his ideas, though he denied Schopenhauer's influence, which he is said to have come across late in life under the influence of Otto Rank. However, between 1830 and 1920 Schopenhauer's ideas were quite popular. The interpretation Schopenhauer gave

to Kantian thought resulted in a "marriage between a neo-Kantian philosophic orientation and the scientific work conducted under the aegis of materialist psychophysiology" (Assoun, 1976), a position held by Theodore Meynert, Johann Herbart, and others, who were well known to Freud.

Whatever the situation may have been, through his work with hysterics, Freud discovered transference, resistance, and the therapeutic framework. In spite of their shared pessimism, Freud was careful to distinguish himself from Schopenhauer in his conception of the death impulse. Also, Freud's metapsychology cannot be confused with a *weltanschauung* (worldview), which characterized Schopenhauer's work as far as Freud was concerned.

When Jacques Lacan attempted to define an ethics of psychoanalysis, he questioned Kant's conception of morality. Although he, like Kant, tried to ground ethics in something unconditioned that is distinct from the Sovereign Good, he rejected the Kantian choice between duty and the categorical imperative. Similarly, he rejects the notion that an ethics of psychoanalysis should be a morality of the superego. For Lacan, the truth of Kant's *Critique of Practical Reason* is found in the marquis de Sade's *Philosophy in the Bedroom* (1990) and, more particularly, in his long theoretical chapter "One more try for the republicans" (Lacan, 1966). The Sadean imperative of enjoyment, "You should seek enjoyment," is a fulfillment of the Kantian categorical imperative. For Lacan, enjoyment is beyond pleasure, or rather, it is the extreme of pleasure, "to the extent that this extreme consists in forcing access to the 'Thing' (*das Ding*)" (Lacan, 1986), that is, the absolute Other of the lost subject. Hence, the ethics of psychoanalysis needs to be grounded

somewhere else: in desire itself. If there is a law of desire, Lacan's associated imperative would be, "Do not give in to your desire." It remains to be determined what this desire is: pure desire, desire of castration, desire of death (Guyomard, 1992)?

For a number of philosophers who want to bring psychoanalysis within the fold of the metaphysics of subjectivity, Kant and Schopenhauer are two links in a chain that, by way of Spinoza and others, joins Freud and Lacan to Descartes (Henry, 1993; Vaysse, 1999).

BERNARD LEMAIGRE

*See also:* Civilization (Kultur); Determinism; Grid; *Inconsistent, L*; Internal/external reality; Love-Hate-Knowledge (L/H/K links); Memoirs of the future; Nostalgia; Otherness; Philosophy and psychoanalysis; Preconception; Taboo; Thing-presentation.

### **Bibliography**

- Assoun, Paul-Laurent. (1976). *Freud, la philosophie et les philosophes*. Paris: Presses Universitaires de France.
- Guyomard, Patrick. (1992). *La jouissance du tragique, Antigone, Lacan et le désir de l'analyste*. Paris: Aubier.
- Henry, Michel. (1993). *The genealogy of psychoanalysis* (Douglas Brick, Trans.). Stanford, CA: Stanford University Press. (Original work published 1985)
- Lacan, Jacques. (1966). Kant avec Sade. In his *Écrits*, pp. 765–790. Paris: Le Seuil. (Original work published 1963)
- Lacan, Jacques. (1986). Le séminaire: livre vii: l'éthique de la psychanalyse. Paris: Le Seuil.
- Sade, Marquis de. (1990). *Justine, philosophy in the bedroom, and other writings*. New York: Grove Press.
- Vaysse, Jean-Marie. (1999). *L'inconscient des modernes: essai sur l'origine métaphysique de la psychanalyse*. Paris: Gallimard.

---

## **KARDINER, ABRAM (1891–1981)**

Abram Kardiner, American physician, psychoanalyst, psychiatrist, and psychocultural theorist, was born in New York City on August 17, 1891, and died in Easton, Connecticut on July 20, 1981.

Born in New York City's Lower East Side of immigrant parents, he suffered early loss and privation, his mother dying when he was only a few years old. But given his ambition and many intellectual gifts, he acquired an excellent education, graduating first from

the City College of New York, and then from Cornell Medical School in 1917. He interned at Mount Sinai Hospital for two years and did his psychiatric residency at Manhattan State Hospital on Ward's Island. After completing his residency, at the urging of Dr. Horace Westerlake Frink, Kardiner sought analysis with Sigmund Freud and was accepted as a student-patient (1921–1922). Freud set two limitations to that analysis: that it not extend past six months, and that the fee per session should be ten American dollars. Kardiner was proud of the fact that Freud acknowledged him as a "menschen kenner" (knower of people). He did supervisory work with Frink in 1923, Abraham Arden Brill in 1923, Otto Rank in 1924, and Franz Alexander in 1927.

A member of the New York Psychoanalytic Society (founded in 1911), he was one of the founders in 1930 of the New York Psychoanalytic Institute, the first psychoanalytic institute in the United States. Kardiner was instrumental in bringing Sándor Rado from Berlin to be its Educational Director. In 1941, Kardiner left the New York Psychoanalytic Institute because of theoretical and political disputes, and in 1945, along with Rado, George Daniels, and David Levy founded the Columbia University Clinic for Psychoanalytic Training and Research, the first psychoanalytic institute that was part of a university medical school. Kardiner was its Director from 1959 to 1967, and Clinical Professor of Psychiatry at Columbia University.

In the 1950s, Kardiner explored critical questions in psychoanalysis that later become integral to psychoanalytic thinking. His first major contribution concerned the impact of culture on personality. This interest arose out of his idea that the curriculum at the New York Psychoanalytic Institute should include Freud's sociological writings. Out of seminars he conducted there, in conjunction with anthropologists, he began to theorize the impact of particular social institutions on character formation in primitive societies. He developed a psychocultural model for the relationship between specific familial patterns and modes of mother-infant bonding and the formation of the "basic personality structure" in different cultures. Published in 1939 as *The Individual and His Society*, this work (along with later publications on the same subject) had a major influence on the emergence of the "culture and personality field" in anthropology and is considered to be a precursor of the object relations theory and ego psychology in psychoanalysis. Although Kardiner had observed war neuroses

much earlier, when he was attending specialist at the U.S. Veterans Hospital (Bronx, 1923–1925), he was only able to theorize them to his satisfaction after he had written *The Individual and His Society*, which dealt with the problems of adaptation. He came to see that in the traumatic neurosis of the war the defensive maneuver to ward off the trauma sometimes destroyed the individual's adaptive capacity. Thus, the traumatic neurosis of war was the result of an adaptive failure, not a conflictual illness. So concluding, Kardiner re-introduced the concept of traumatic neurosis into psychoanalytic theory. Kardiner (with Lionel Ovesey) applied his knowledge of the impact on development of trauma and specific cultural configurations to the study of the effect on blacks of institutionalized white racism.

Kardiner was an adherent of and contributor to adaptational theory, a precursor of ego psychology generally associated with the name of Sándor Rado. Recognizing the limitations of libido theory in conceptualizing the war neurosis and cross-cultural variations, Kardiner (with Lionel Ovesey and Aaron Karush), wrote one of the first major critiques of libido theory. The libido theory, Kardiner believed, was a case of the instinctual tail wagging the adaptational dog. He emphasized that frames of reference were of value only as long as they provided rational explanations for clinical data and opened channels to research and new knowledge. In 1977, Dr. Kardiner wrote a memoir entitled *My Analysis with Freud*, which drew a portrait of the way Freud conducted an analysis and detailed some of the early history of the psychoanalytic movement in the United States, and in which Kardiner displayed, among other gifts, his great skill as a raconteur. Like Freud, Kardiner continued seeing patients until shortly before his death at age 89.

ETHEL SPECTOR PERSON

See also: American Psychoanalytic Association; Civilization (Kultur); Horney-Danielsen, Karen; United States.

### **Bibliography**

- Kardiner, Abram. (1939). *The individual and his society*. New York: Columbia University Press.
- . (1941). *The traumatic neuroses of war*. New York: Paul B. Hoeber.
- . (1945). *The psychological frontiers of society*. New York: Columbia University Press.

Kardiner, Abram; and Spiegel, Herbert. (1947). *War, stress and neurotic illness*. New York: Paul Hoeber.

Kardiner, Abram; and Ovesey, Lionel. (1951). *The mark of oppression*. New York: W.W. Norton.

Kardiner, Abram; Ovesey, Lionel; and Karush, Aaron. (1959). A methodological study of Freudian theory I-IV. In *Journal of Nervous and Mental Diseases*, 129 (1), 11–19; 129 (2), 133–143; 129 (3), 207–221; 129 (4), 341–156.

Lohser, Beate; and Newton, Peter. (1996). *Unorthodox Freud: the view from the couch*. New York, Guilford Press.

Manson, William C. (1988). *The psychodynamics of culture: Abram Kardiner and neo-Freudian anthropology*. New York, Greenwood Press.

Swerdloff, Bluma. (1981). A tribute to Abram Kardiner, 1891–1981. *Bulletin of the American Psychoanalytic Association*, 21, 42–44.

## **KATAN, MAURITS (1897–1977)**

Maurits Katan, psychoanalyst and physician, was born November 25, 1897 in Vlaardingen, South Holland, the Netherlands, the son of Jacob and Bertina Katan. He died on April 3, 1977 in Sanibel, Florida. Little is known of his early years except that he came from a large family and was the only son and youngest child.

Katan's initial medical training was as a neurologist, his initial analytic training in the Netherlands before going to Vienna in the 1930s to enter analysis ultimately with Anna Freud. In Vienna he met and married Anny Rosenberg (Angel) and they returned to the Netherlands just prior to the start of World War II. He survived the war in hiding, active in the underground, sheltered by the Dutch court portraitist, Robert Bruyn.

Katan's psychoanalytic work was very much focused on understanding psychosis, particularly schizophrenia, and his concepts of a pre-psychotic phase and the split in the schizophrenic with his non-psychotic part were integral in his thinking. He focused greatly on Daniel Paul Schreber who, in one sense, was his companion during the isolation of the war years. His clinical seminars with psychotic patients revealed an understanding tact and ability to communicate rare and unforgettable to observe.

His importance lay in coming to Cleveland, Ohio, after the war to become one of the first professors of psychoanalysis in America, with his appointment at the Case Western Reserve University School of

Medicine. His impact derived from his modest brilliance as the epitome of the analytic scholar.

While Katan focused on psychotic phenomena, his colleagues deeply respected his insights with neurotic patients, and many analysts nationwide came to Cleveland to present their work and obtain his insights. In addition his literary explorations, particularly but not exclusively of Henry James's work, were masterpieces.

ROBERT A. FURMAN

*See also:* Blank/non-delusional psychoses; Katan-Rosenberg, Anny; Netherlands.

### **Bibliography**

- Katan, Maurits. (1953) Schreber's prepsychotic phase. *International Journal of Psychoanalysis*, 34 (1), 43–51.
- . (1954) The importance of the non-psychotic part of the personality in schizophrenia. *International Journal of Psychoanalysis*, 35 (2), 119–128.
- . (1959) Schreber's hereafter: Its building-up (Aufbau) and its downfall. *Psychoanalytic Study of the Child*, 14, 314–382.
- . (1962) A causerie on Henry James's "The Turn of the Screw." *Psychoanalytic Study of the Child*, 17, 473–493.
- . (1964) Fetishism, splitting of the ego, and denial. *International Journal of Psychoanalysis*, 45 (2–3), 237–245.

## **KATAN-ROSENBERG, ANNY (1898–1992)**

Anny Katan-Rosenberg, psychoanalyst and physician, was born May 1, 1898 in Vienna, Austria, and died in Cleveland, Ohio in the U.S. on December 24, 1992.

The daughter of Mrs. Judith and Dr. Ludwig Rosenberg, she grew up in close contact with the origins of psychoanalysis as her pediatrician father and her pediatrician uncle were two of Freud's three weekly tarok card playing partners. Her uncle Oskar Rie was the Freuds' pediatrician, her cousins later spouses of Ernst Kris and Herman Nunberg. Anna Freud was a childhood acquaintance but not a particularly close companion. Ill in infancy as a failure-to-thrive baby, she was nonetheless most physically active from a young age, and was a skier, mountain climber, and horseback rider all her life.

Her analytic training was marked by a number of unusual features: prior to her analysis with Anna Freud, her first analyst became psychotic and her next two were of limited competence. For her graduation from

training she presented not one but two papers; the first was "Optimism and Denial," and the second was "The Role of Displacement in Agoraphobia," a contribution to object loss. In her adolescence, she joined the Anna Freud group of pioneering child psychoanalysts.

She played a very active role in the political storms of prewar Vienna and, after marrying fellow analyst Maurits Katan and moving to the relative safety of the Netherlands, returned many times to Vienna at extraordinary personal risk to facilitate the escape of many analysts, such as Margaret Mahler. She survived the war in the Netherlands on false papers along with her daughter, while her husband and his son (from a prior marriage) survived in hiding. With the support and encouragement of Anna Freud, she and her husband moved to Cleveland, Ohio after the war to establish a psychoanalytic community there.

In Cleveland Katan directed her attention primarily to child analysis, starting a therapeutic preschool in 1950, now the Hanna Perkins School. There she developed the new technique of treating the preschool child by way of its parents. Katan started a child therapy training program—an analytic training program for non-medical therapists, modeled on Anna Freud's Hampstead Child Therapy Course—supported by a child analytic clinic where analysis was available to children as needed on an ability to pay basis. In this setting she developed a unique child psychoanalytic research complex, still active as the Hanna Perkins Center for Child Development.

Her work was marked by the constant practical application and utilization of child analysis, never compromising on standards of training or research. Dr. Anny Katan was a fearless analyst who pursued her analytic goals undaunted by the opposition in the U.S. to lay analysis. The courage that marked her years in Vienna and in the Netherlands during the war never failed her. An astute clinician, she prided herself on being "Anny Katan, Psychoanalyst," continuing in active practice into her nineties.

ROBERT A. FURMAN

*See also:* Katan, Maurits.

### **Bibliography**

- Katan, Anny. (1951). The role of displacement in agoraphobia. *International Journal of Psycho-Analysis*, 32, 1–10.

- . (1959). The nursery school as a diagnostic help to the child guidance clinic. *Psychoanalytic Study of the Child*, 14, 250–264.
- . (1961). Some thoughts about the role of verbalization in early childhood. *Psychoanalytic Study of the Child*, 16, 184–189.
- . (1972). The infant's first reaction to strangers: distress or anxiety? *International Journal of Psycho-Analysis*, 53, p. 501–503.
- . (1973). Children who were raped. *Psychoanalytic Study of the Child*, 28, 208–224.

### KATHARINA, CASE OF

“Katharina,” whose real name, Aurelia Öhm-Kronich, was uncovered by Peter Swales (1988), was born on January 9, 1875, in Vienna, and died on September 3, 1929, in Reichenau. Her case was the third discussed by Sigmund Freud in the *Studies on Hysteria* (1895d).

“The etiology of the neurosis pursued me wherever I went, just like the song of Marlborough the Briton while he was traveling. Recently, while on the Rax, the daughter of the innkeeper came to see me; it has been a good case for me.” Freud wrote this in a letter to Wilhelm Fliess, on Sunday, August 20, 1893, about the improvised consultation he was asked to provide during his vacation for the young daughter of the innkeeper, who complained of a suffocating feeling, accompanied by the vision of a terrifying face. “Was I to make an attempt at an analysis? I could not venture to transplant hypnosis to these altitudes, but perhaps I might succeed with a simple talk. I should have to try a lucky guess. I had found often enough that in girls anxiety was a consequence of the horror by which a virginal mind is overcome when it is faced for the first time with the world of sexuality” (1895d, p. 127).

Freud concluded:

At that time she had carried about with her two sets of experiences which she remembered but did not understand, and from which she drew no inferences. When she caught sight of the couple in intercourse, she at once established a connection between the new impression and these two sets of recollections, she began to understand them and at the same time to fend them off. There then followed a short period of working-out, of “incubation”, after which the symptoms of conversion set in, the vomiting as a substitute for moral and physical disgust. This solved

the riddle. She had not been disgusted by the sight of the two people but by the memory which that sight had stirred up in her (1895d, p. 131).

At this time Freud was greatly excited by his discovery of the sexual etiology of neurosis, but was unable to convince Josef Breuer of its validity. He also introduced the theory of the “hysterical proton pseudo,” a primal sexual scene that has been overlooked and whose memory is reawakened by a recent sensation. As Freud noted, this resembled what “Charcot liked to describe . . . as the ‘period of psychological working-out’” (p. 134), which separated the trauma from the appearance of symptoms.

Katharina's cure was akin “not so much [to] an analysed case of hysteria as a case solved by guessing” (p. 133) noted Freud, whose work as a hypnotist made him seem more like a magician than a scientist. A note added to the text in 1924 corrects the historical record with the following information: “Katharina was not the niece but the daughter of the landlady. The girl fell ill, therefore, as a result of sexual attempts on the part of her own father” (p. 134)

ALAIN DE MIJOLLA

*See also:* Adolescence; Case histories; “Neurasthenia and ‘Anxiety Neurosis’”; Primal scene; Seduction scenes; *Studies on Hysteria*.

### Bibliography

- Ellenberger, Henri F. (1970). *The discovery of the unconscious: The history and evolution of dynamic psychiatry*. New York: Basic Books.
- . (1950a [1887–1902]). Extracts from the Fliess papers. *SE*, 1: 173–280.
- Freud, Sigmund, and Breuer, Josef. (1895d). *Studies on hysteria*, *SE*, 2.
- Swales, Peter J. (1988). Freud, Katharina and the first “wild analysis.” In P. E. Stepansky (Ed.), *Freud: Appraisals and reappraisals*, Hillsdale, NJ-London: The Analytic Press, p. 80–164.

### KEMPER, WERNER WALTHER (1899–1975)

Werner Walther Kemper, the German physician and psychoanalyst, was born on August 6, 1899, at Hilgen in the Rhineland, and died in Berlin on September 27, 1975.



He was the second of seven children, his father being a village pastor in Westphalia and his mother coming from a family of Rhineland landowners. Having taken the special session of the baccalaureate in 1917, he was mobilized on the Western Front (the battles of the Somme, the Marne, and Champagne, escaping only after being buried alive in an explosion).

He began to study medicine in 1919, specializing in internal medicine and obstetric surgery. He was particularly interested in hypnosis and psychosomatic illness. He gave up on the university career he had initially planned in order to become medical director of a reputable clinic in Berlin-Grünewald.

He did the first part of his analytic training in the Berlin Psychoanalytic Institute in 1928 and his training analysis with Carl Müller-Braunschweig. He had supervision analysis, instituted for the first time in this institute in 1923, with Felix Boehm, Otto Fenichel, Jenö Hárník, and Ernst Simmel. At the end of his training Kemper set up in private practice as a physician and psychoanalyst. He married the graphologist and future psychoanalyst Kattrin Kemper, with whom he had three sons. Following his conference on the “Genesis of genital erogeneity and the orgasm,” he became a regular member of the German Psychoanalytic Society (DPG) in 1933, dean of the Berlin Psychoanalytic Institute in 1934, and a member of the board of directors of the DPG in 1936.

Beginning in 1941 and following the arrest and execution of John F. Rittmeister for acts of resistance, he divided his time between his private practice and the polyclinic that he managed from 1942 until the end of the war. In spring 1946, with Harald Schultz-Hencke, he created the Central Institute for Psychogenic Illness for the Berlin insurance company, which led German insurance companies to recognize analytic psychotherapy, and in 1947 he became director of the DPG’s new Institute for Psychotherapy, also established in Berlin.

To the best of our knowledge he was the only German psychoanalyst who, after twelve years of psychoanalysis under the Nazi regime, enjoyed the unreserved confidence of the International Psychoanalytic Association. In 1948, with the support of Ernest Jones, he became the first training analyst in Rio de Janeiro, where he then lived and where he founded, along with Mark Burke and Domicio A. Camara, a psychoanalytic society based on the Berlin model and which was at the origin of the stormy development of the Rio de

Janeiro psychoanalytic institute. Having worked as a training analyst for twenty years, he left his mark on several generations of Brazilian candidates.

He returned to Berlin in 1967 for health reasons and until his death in 1975 he lived apart from his German colleagues who had never emigrated. He never accepted the break between the two German analytic societies (DPG and DPV).

Under the Third Reich, Kemper published work on the psychotherapeutic indications in sexual disorders and sterility. His major work, *Die Störungen der Liebesfähigkeit beim Weibe* (Disorders in women’s capacity to love; 1942), had important repercussions and was republished several times (1943, 1967, 1972). His monograph on enuresis and its pathogenic factors, published in 1949, is the result of his experience in the polyclinic. Written for a cultivated public, his book entitled *Die Traum und seine Be-Deutung* (Dreams and their meaning; 1955) is a convincing presentation of the technique of dream interpretation and comprises a comparative study of the various theoretical schools based on his psychoanalytic experience in the 1930s and 1940s. In Brazil, Kemper criticized Melanie Klein’s position on the role of the transference in the actual analytic situation and the resulting emotional processes in the counter-transference, subjects he increasingly included in his therapeutic work. His book on group therapy, published in 1960, and his plan to publish Heinrich Racker’s contributions on the subject of transference and counter-transference were destined to familiarize German readers with Latin American psychoanalysis and its practice of group work. His other clinical works were: *Der Patient schweigt* (The silent patient; 1948), *Die Abstinenzregel in der Psychoanalyse* (The rule of abstinence in psychoanalysis; 1954–55), *Organwahl und psychosomatische Medizin* (Organ choice and psychosomatic medicine; 1954).

With remarkable skill, Kemper managed to live through the Third Reich without compromising himself too much, in spite of occupying a position of responsibility, and without undermining his identity as a Freudian psychoanalyst, so much so that, after the war, he immediately reestablished contact with international psychoanalysis and proved himself both active and fecund. In Brazil, in spite of the situation there and circumstances that were personally difficult for him, he laid the bases for the establishment and expansion of psychoanalysis by means of collegial exchanges with Adelheit Koch (São Paulo), Marie

Langer, and Heinrich Racker (Buenos Aires). In spite of his efforts to transmit his experience to German-speaking countries, he shared the same fate as almost all emigrant analysts, that of being scarcely recognized in his native Germany.

KARIN DITTRICH

*See also:* Berliner Psychoanalytische Poliklinik; Brazil; Germany; Göring, Matthias Heinrich; Schultz-Hencke, Harald Julius Alfred Carl-Ludwig.

### **Bibliography**

Brecht Karen, et al. (1985). *“Here life goes on in a most peculiar way”*: *Psychoanalysis before and after 1933*. Hamburg: Michael Kellner (1993).

Grinberg, Léon, et al. (1960). Psychoanalytische Gruppentherapie, in Werner Kemper (ed.), *Theorie und Praxis*. Stuttgart: Klett.

Kemper, Werner. (1943). *Der Störungen dere Liebesfähigkeit beim Weibe*. Leipzig: Thieme.

———. (1955). *Der Traum und seine Bedeutung*. Hamburg: Rowohlt.

Pongratz, Ludwig J. (1973). Werner W. Kemper. In *Psychotherapie in Selbstdarstellungen* (pp. 259–345). Bern: Hans Huber.

## **KESTEMBERG-HASSIN, EVELYNE (1918–1989)**

Evelyne Kestemberg-Hassin, a French psychoanalyst and a permanent member and former president of the Société psychanalytique de Paris (Paris Psychoanalytic Society), was born on May 28, 1918, in Constantinople and died on April 17, 1989, in Paris. The daughter of a French father (who was a merchant) and a Jewish Russian mother (who fled the revolution of 1917), she came to France soon after she was born. She earned a university degree in philosophy. In 1942 she left occupied France for Mexico, and in the course of her travels she met Jean Kestemberg, who soon became her husband. On her return to France in late 1945, she joined the Communist Party and remained in the party until 1956.

After undergoing analysis with Marc Schlumberger, she devoted herself to psychoanalysis. An analyst who worked with children, she practiced group therapy as inspired by Jacob Moreno at the Centre psychopédagogique Claude-Bernard (Claude Bernard Psychoanalytic Training Center) and eventually joined Serge

Lebovici and René Diatkine in their work. Together they created individual psychoanalytic psychodrama. Their assessment of ten years of psychodramatic practice with children and adolescents (Lebovici et al., 1958) showed a wide range of perspectives in their research. *Le psychodrame psychanalytique* (1987; Psychoanalytic psychodrama), written in collaboration with Philippe Jemmet, was the culmination of her long practice.

At the time of the creation of the Centre Alfred-Binet (Alfred Binet Center), founded by Philippe Paumelle in 1958 and part of the Centre de santé mentale (Mental Health Center) of Paris, Kestemberg was working closely with Diatkine and Lebovici. Her article “L’identité et l’identification chez les adolescents” (1962; Identity and identification in adolescents) was a landmark. Elected as a training analyst the following year, she was the first nonphysician woman since Marie Bonaparte to become a permanent member of the Paris Psychoanalytic Society. The report for the 1965 Congress of Psychoanalysts Working in the Romance Languages, written jointly with Jean Kestemberg, compared her authority in developmental psychoanalysis to those of the Americans Heinz Hartmann, Ernst Kris, and Rudolf Löwenstein.

As president of the Paris Psychoanalytic Society in 1971, Kestemberg actively took part in the work of the society, and in 1980 she became coeditor, with Jean Gillibert and Claude Girard, of the *Revue française de psychanalyse*. She also collaborated with Raymond de Saussure in forming the Fédération européenne de psychanalyse (European Federation of Psychoanalysis). The year 1972 saw the publication of *La faim et le corps: une étude psychanalytique de l’anorexie mentale* (Hunger and the body: a psychoanalytic study of mental anorexia), written by Kestemberg together with Simone Descobert and Jean Kestemberg. This book led to the theoretical notion of “cold,” or nondelusional, psychosis and remains an authority on its topic.

On the death of Jean Kestemberg, who, with the help of René Angelergues, had just created the Centre de psychanalyse et de psychothérapie du XIIIe (Psychoanalytic and Psychotherapeutic Center of the Thirteenth Arrondissement, Paris) for psychotic patients, Evelyne Kestemberg assumed the directorship of the center. There, from 1975 to 1988, she avidly pursued her clinical and theoretical teaching activities and took part in seminars, notably as part of a small circle that included Alain Gibault, Colette Guedeney, and Benno

Rosenberg. She developed a deeper understanding of psychosis and put in place such notions as a fetishistic relation to the object, a phobia of mental functioning, and the third-party persona. She set herself apart from Melanie Klein: her intent was to not be identified with anyone else. The center's publication, *Les cahiers du centre* (Center Notes), launched in 1980, set for itself the mission of presenting, with clinical illustrations, such notions as the splitting of the ego, negation, the delusional solution, excitation, and word presentations and thing presentations. A remarkable clinical practitioner, Kestemberg was part of a pioneering and creative generation.

LILIANE ABENSOEUR

*See also:* Adolescence; Anorexia nervosa; Autistic capsule/nucleus; Displacement of the transference; Fédération européenne de psychanalyse; France; Kestemberg, Jean; Société psychanalytique de Paris and Institut de psychanalyse de Paris.

### **Bibliography**

Abensour, Liliane. (1999). *Evelyne Kestemberg*. Paris: Presses universitaires de France.

Kestemberg, Evelyne. (1962). L'identité et l'identification chez les adolescents: problèmes techniques et théoriques. *Psychiatrie de l'enfant*, 5 (2): 441–552.

———. (1978). La relation fétichique à l'objet: quelques notations. *Revue française de psychanalyse*, 42 (2): 195–214.

———. (1999). *L'adolescence à vif*. Paris: Presses universitaires de France. Kestemberg, Evelyne. (2001). *La psychose froide*. Paris: Presses universitaires de France.

Kestemberg, Evelyne, and Jeammet, Philippe. (1987). *Le psychodrame psychanalytique*. Paris: Presses universitaires de France.

Kestemberg, Evelyne; Kestemberg, Jean; and Descobert, Simone. (1972). *La faim et le corps: une étude psychanalytique de l'anorexie mentale*. Paris: Presses universitaires de France.

Lebovici, Serge; Diatkine, René; and Kestemberg, Evelyne. (1958). Bilan de dix ans de thérapeutique par le psychodrame chez l'enfant et l'adolescent. *Psychiatrie de l'enfant*, 1 (1), 63–180.

---

## **KESTEMBERG, JEAN (1912–1975)**

Jean Kestemberg, psychiatrist, psychoanalyst, and full member of the Paris Psychoanalytic Society, was born

at Kielce in Poland on December 11, 1912 and died while traveling on August 25, 1975.

Although he was born into a religious and bourgeois Jewish family in Poland, he distanced himself from the family milieu as an adolescent and became a secret militant for the Communist Party, from which he was expelled in 1956. He went to Paris during the 1930s to study medicine, which he was forbidden to do in Poland because of the quota applied to Jews. He joined the International Brigade as a doctor in 1937 and went to work in the Spanish Civil War. As an active member of the Polish Resistance during World War II, he was forced to travel to Mexico in 1942. Evelyne Hassin, whom he met on the boat, soon became his wife.

He returned to France after the Liberation and once he had been naturalized he presented his thesis, the first thesis on occupational medicine. He became assistant to Louis Le Guiland in his psychiatric department at Villejuif while simultaneously being analyzed by Jacques Lacan. He was elected a member of the Paris Psychoanalytic Society in 1953, then went on to become a full member. His article *À propos de la relation érotomaniaque* (On the erotomaniac relation), which illustrates his interest in psychosis, won the first Maurice Bouvet prize in 1962. Working in close collaboration with his wife, Jean Kestemberg practiced the individual psychoanalytic psychodrama and with her he drafted the report to the 1965 Congress of Romance-Language Psychoanalysts, *Contribution à la perspective génétique en psychanalyse* (Contribution to the Genetic Perspective in Psychoanalysis) and co-authored *La Faim et le Corps* (Hunger and the Body) in 1972.

In order to introduce psychoanalysis to psychotic patients outside the hospital, in 1974 with the help of René Angelergues, he created the Center for Psychoanalysis and Psychotherapy within the framework of the Center for Mental Health in Paris. Following his sudden death on August 25, 1975, Evelyne Kestemberg continued the task her husband had set himself. Jean Kestemberg was a warm man who was full of humor and invention.

LILIANE ABENSOEUR

*See also:* Anorexia nervosa; Autistic capsule/nucleus; France; Kestemberg-Hassin, Evelyne; *Revue française de psychanalyse*.

### Bibliography

Kestemberg, Evelynne, Kestemberg, Jean, and Decobert, Simone. (1972). *La Faim et le Corps: une étude psychanalytique de l'anorexie mentale*. Paris: Presses Universitaires de France.

Kestemberg, Jean (1962). À propos de la relation érotomaniaque, *Revue française de psychanalyse*, 26, 5, 533–587.

---

## KHAN, MOHAMMED MASUD RASA (1924–1989)

Masud Khan, an English psychoanalyst of Indian origin, was born in 1924 in Montgomery (Sahival) in the Indian Punjab, and died in 1989 in London. Khan's father was a wealthy landowner who raised horses. His mother, a dancer, was only nineteen when he was born. His childhood, spent "between a polygamous father and a mother who was dreamy and distant," was certainly psychologically complex. Khan wanted to be his father's favorite, although he was treated as just another of his many children. The world in which he lived, the world of colonial India, was deeply divided according to sex, a complex caste system, and the various peoples of that diverse country. When he was eight years old, Khan was entrusted to a tutor trained at Oxford, who provided him with an extremely British education. He was deeply affected by the death of a sister when he was eighteen. His love for her was perhaps greater than for any other woman in his life. Her death was almost immediately followed by that of his father, the more influential of his parents.

The grief that followed the death of his sister and father led him to seek psychotherapy. His therapist encouraged him to get involved in the British Psycho-Analytical Society. After studying literature at the University of the Punjab (in Faisalabad and Lahore), he wrote his thesis on James Joyce's *Ulysses* and left for Great Britain in 1946, ostensibly for minor surgery.

Khan was accepted as a student of psychoanalysis, analyzed successively by Ella Sharpe, John Rickman, and Donald Winnicott, and became a training analyst in 1959. His career within the International Psychoanalytical Association was brilliant, and his publishing activities intense. He was appointed editor of the International Psychoanalytical Library and the *International Journal of Psychoanalysis*, and coeditor of the *Nouvelle revue de psychanalyse*, for which he wrote twenty-seven articles between 1970 and 1987.

During his tenure with the *Nouvelle revue de psychanalyse*, he became close friends with Jean-Bertrand Pontalis, who referred to Khan as "our close foreigner." Upon Khan's death Pontalis wrote, "One day I may write about our friendship, a friendship that lasted for more than twenty years—in spite of the temporary flare-ups, it remained solid and steadfast—only because the Channel and the use of 'vous [you]' helped us maintain a certain distance. . . . Thanks to Khan, the review was opened up to people like Winnicott, Marion Milner, and Harold Searles, without being unduly swayed by them" (Bollas, Pontalis, et al., 1989).

An excellent teacher, Khan trained a number of analysts in the Independents group of the British Psycho-Analytical Society. His narrative powers were excellent, and his writings are remarkable. Typical are *The Privacy of the Self* (1974) and *Alienation in Perversions* (1979). With respect to *The Privacy of the Self*, Christopher Bollas remarked that one of Khan's favorite Persian aphorisms was, "Where am I but in the place where no news comes to me, even about myself" (Bollas et al., 1989).

Khan had to address the problems of schizoid personalities and their thought processes early in his career. He saw that they were a major problem for clinical therapy and contemporary psychoanalytic theory, and he felt that new concepts were needed to describe them. These included the concept of "cumulative trauma" (1953), a trauma that went unnoticed until its effects appeared during adolescence. He also devised new methods of listening and interpreting and, more radically, experiencing analysis. With these methods, classic notions like trauma, transference, and regression, as well as more recent ones like dependence and "false self," can then be understood when they emerge fully embodied.

During the 1970s Khan's practice was challenged within the British Psycho-Analytical Society primarily because of personality conflicts and Khan's aristocratic tastes. Complaints were lodged against him, and in 1975, after considerable hesitation, his title as a training analyst was withdrawn. At the same time he began suffering from lung cancer, which he considered a form of "outrage" (the title of one of his last articles). In his final work, *When Spring Comes* (1988), Khan was so revealing in his discussions of technique and counter-transference that he was accused of madness, anti-Semitism, and bisexuality. The affair caused a scandal, and Khan was thrown out of the British

Psycho-Analytical Society in 1988. Only in 1992 was he somewhat rehabilitated by Adam Limentani, then president of the International Psychoanalytical Association. Little light has been shed on the events that had led to his expulsion.

As Christopher Bollas wrote in “Portrait of an Extraordinary Psychoanalytic Personality” (1989), “Masud Khan was one of the most enigmatic and controversial of psychoanalysts.” Aside from the controversy, Khan remains an influential figure in the psychoanalytic movement because of his sophistication, curiosity, approach to therapy, and flexibility in solving problems within the framework of psychotherapy. Didier Anzieu, who greatly admired Khan, wrote, “His writings remain but his death has been painful to me: psychoanalysis has lost its prince” (Bollas, Pontalis, Anzieu, et al., 1989).

BERNARD GOLSE

*See also:* As if personality; Dependence; Great Britain; Self, the; Sleep/wakefulness; Voyeurism.

### **Bibliography**

- Bollas, Christopher. (1989, June 26). Obituary: Masud Khan—Portrait of an extraordinary psychoanalytic personality. *The Guardian*, p. 39.
- Bollas, Christopher; Pontalis, Jean-Bertrand; Anzieu, Didier; et al. (1989). In *Memoriam Masud Khan, 1924–1989. Nouvelle revue de psychanalyse*, 40, 333–359.
- Khan, Masud. (1974). *The privacy of the self*. London: Hogarth Press.
- . (1979). *Alienation in perversions*. London: Hogarth Press and Institute of Psycho-Analysis.
- . (1983). *Hidden selves: between theory and practice in psychoanalysis*. New York: International Universities Press.
- . (1988). *When spring comes*. London: Chatto and Windus.

## **KLEIN-REIZES, MELANIE (1882–1960)**

Melanie Klein, British psychoanalyst, was born in Vienna on March 30, 1882, and died on September 20, 1960, in London.

Klein came from a traditional, though not orthodox, Jewish background in the Austro-Hungarian Empire. Her school-age ambition to become a doctor was never realized, due to her complicated relationship

with her dominant and intrusive mother, who, Klein felt, favored her brother. She therefore had no university education, but read widely and independently in subjects that interested her.

Her older sister died when Klein was four years old. She lost her brother Emmanuel when she was twenty, one year before her marriage to Arthur Klein, a chemical engineer.

Klein was close to her mother in an ambivalent relationship which caused her periods of considerable depression. Her experience of death and bereavement continued when her mother died in 1914, a few months after Klein's third child was born. These events coincided also with her husband being conscripted into the army. Klein's three children were born in 1904, 1907, and 1914.

She had become acquainted with psychoanalysis the year before, and shortly after the traumatic events of 1914, she sought analysis with Sándor Ferenczi, who worked with her until 1917. He was away from Budapest at times on military duty, and her analysis was probably interrupted. Ferenczi encouraged her to take an interest in the psychoanalytic understanding of children, as he was interested in following up Freud's “Little Hans” case. Klein began an investigation of her own children. She presented a paper in 1919 detailing these preliminary studies to the Hungarian Psycho-Analytical Society, and was made a member. However, later that year she left Hungary because of anti-Semitism and the post-war political turmoil. She traveled with her children to Berlin, while her husband worked in Sweden. They were essentially divorced from this point. In Berlin she developed her observational technique and a rigorous interpretive psychoanalysis with child patients. She went into analysis with Karl Abraham, who left an enduring mark on the development of her psychoanalytic ideas.

Klein then met Alix Strachey, who was also in analysis with Abraham. Strachey was very impressed by the presentations that Klein made to the Berlin Society (Strachey, 1986) and they became friends. Alix Strachey reported her impressions to her husband James and through this link Melanie Klein arranged to come to London to give a series of lectures in 1925. Her work was greatly appreciated in the British Psycho-Analytical Society. This was the first time her efforts had met with such acclaim; when she was invited to come permanently to London, she agreed with little hesitation. She arrived in 1926, and her children came

soon after. She was very happy in the first years. She found strong support from most of her colleagues in London before Anna Freud developed a different form of child analysis (1927) and criticized Klein's (Grosskurth, 1986).

Klein's clinical skill had a profound effect on the quality of the work of the whole Society. She was very much a teacher and innovator. Something of a backlash began however, shortly before she read her paper on the depressive position in 1935. Edward Glover, who also been analyzed by Abraham and who was at the time analyzing Klein's daughter Melitta, began controversial debate, disputing her work and her conclusions and suggesting that she was no longer practicing psychoanalysis.

When Anna Freud moved to London with her father in 1938 after Germany had annexed Austria, Klein became very worried that her own work would be jeopardized. She was resolute in standing by her ideas, and the Society arranged a series of lectures in 1943 to debate the nature and value of Melanie Klein's discoveries and ideas. The outcome of these "Controversial Discussions" was a stalemate, which allowed both Klein and Anna Freud to develop separate schools of psychoanalysis within the British Society. The majority of the British psychoanalysts formed a middle or independent group aligned to neither Freud nor Klein.

Klein's first major contribution was to create a method of child analysis which extended the tentative attempts of Hermine Hug-Hellmuth (1921). Her new technique was characterized by her astute and detailed clinical observation, and by her view that an analysis of a child demanded as rigorous an interpretative method as an adult analysis. This produced material which partly confirmed the theoretical notions that Freud had inferred in the development of children. But she described them in much greater detail and could point to significant modifications.

She found evidence to disagree with Freud on some points: firstly, she was forced to conclude that the libidinal phases were not conveniently separated in time, but instead there was much overlap; secondly, the Oedipus complex was active in a very primitive form from the earliest phases, and was colored by oral and anal impulses as well as genital ones; and thirdly, the super-ego did not supersede the Oedipus complex but probably preceded it also in a very primitive and harsh

form. These conclusions remain contentious (Hinshelwood, 1991).

Her later descriptions of the depressive position and paranoid-schizoid positions were entirely original, and have long provoked intense debate. The patterns of anxiety, defenses, and relationships which these positions represent are now quite widely accepted. And certain elements of them, notably "projective identification," is of great importance in the teaching of many institutes and schools of psychoanalysis.

Klein always gave her allegiance to Freud's theory of the death instinct, and the early observations she made of the aggression and fear that children suffer promoted the view, against Freud, that this instinct is not clinically silent. Her last major contribution, the notion of "primary envy," brought the death instinct clearly under clinical observation.

All of Melanie Klein's conclusions, as well as her technique, have been and remain hotly debated. However, her views have been increasingly discussed—and understood. There are large and growing groups of psychoanalysts in many countries who would now regard her work as standard psychoanalysis.

ROBERT D. HINSHELWOOD

*Work discussed:* *Envy and Gratitude; Psychoanalysis of Children, The*

*Notions developed:* Breast, good/bad object; Combined parent figure; Depressive position; Envy; Oedipus complex, early; Paranoid position; Paranoid-schizoid position; Projective identification; Reparation; Richard, case of; Splitting of the object; Unconscious fantasy.

*See also:* Abandonment; Aggressiveness/aggression; Ambivalence; Anality; Anorexia nervosa; Anxiety; Archaic; Archaic mother; Argentina; Bick, Esther; Bion, Wilfred Ruprecht; Breastfeeding; Brierly, Marjorie Flowers; British Psycho-Analytical Society; Child analysis; Childhood; Children's play; Controversial Discussions; Creativity; Cruelty; Death instinct (Thanatos); Defense; Depression; Disintegration, feelings of, (anxieties); Feminism and psychoanalysis; Fornari, Franco; France; Freud, Anna; Frustration; Gift; Great Britain; Guilt, feeling of; Heimann, Paula; Imago; Infans; Infant development; Infantile omnipotence; Infantile psychosis; Infantile sexual curiosity; Internal object; Isaacs-Sutherland, Susan; Italy; Jones, Ernest; Love-Hate-Knowledge (L/H/K links); Money-Kyrle, Roger Earle; Object; Oedipus complex; Oral stage; Phobias in children; Primal scene; Primal, the; Primary object; Privation; *Psychoanalytical Treatment of Children*; Psychotic defenses; Quota

of affect; Riviere-Hodgson Verrall, Joan; Rosenfeld, Herbert Alexander; Schmideberg-Klein, Melitta; Self; Splitting; Strachey-Sargent, Alix; Sublimation; Superego; Technique with children, psychoanalytic; Thoughts; Tics; Transference in children; Winnicott, Donald Woods.

### **Bibliography**

- Freud, Anna. (1927). Introduction to the technic of child analysis. (L. Pierce Clark, Trans.). New York: Arno Press, 1975.
- Grosskurth, Phyllis. (1986). *Melanie Klein. Her world and work*. London, Hodder & Stoughton, 501 p.
- Hinshelwood, Robert. (1994). *Clinical Klein*. London, Free Association Books.
- Hug-Hellmuth, Hermine. (1921). On the technique of child analysis. *International Journal of Psycho-Analysis*, 2, p. 287–305.
- Klein, Melanie. (1975). *The writings of Melanie Klein*. London, Hogarth, 4 vol.
- Segal, Hanna. (1964). *Introduction to the work of Melanie Klein*. London, Heinemann; republ. 1973, London, Hogarth; repr. 1988, London, Karnac Books.
- Spillius, Elisabeth. (1988). *Melanie Klein today*. London, Routledge.

---

## **KLINISCHE STUDIE ÜBER HALBSEITIGE CEREBRALLÄHMUNG DER KINDER [CLINICAL STUDY OF INFANTILE CEREBRAL PARALYSIS]**

This work, a monograph on the group of paralytic syndromes that constitute cerebral diplegia in children, has not been reprinted or translated.

The introduction presents the history of research on this illness. (I) Thirty-five case histories (II) and their classification into different groupings (III) make it possible to show their characteristics (IV). This analysis (V) is followed by a discussion of pathological anatomical factors (VI). The illness's relationship to epilepsy and infantile poliomyelitis, the differential diagnosis, and treatment options are discussed (VII–X). The final chapter contains a bibliography with 180 references.

This study refutes previous attempts to identify the etiological, cerebral localization-related, or process-related causes of this pathology: “The clinical picture of infantile cerebral paralysis proves to be independent of these etiologies.” This diagnosis had only a descrip-

tive value until the mechanisms of the central nervous system in adults and children became known. Important points to consider are the differential diagnosis from infantile hysteria, and the significance of psychological factors in the triggering of this disease.

JOHANN GEORG REICHENEDER

See also: Institut Max-Kassowitz.

### **Source Citation**

Freud, Sigmund, and Rie, Oscar. (1891). *Klinische Studie über halbseitige Cerebrallähmung der Kinder*. Vienna: M. Perles.

### **Bibliography**

- Brun, Rudolph. (1936). Sigmund Freuds Leistungen auf dem Gebiet der organischen Neurologie. *Schweizer Archiv für Neurologie, Neurochirurgie*, 37, 200–207.
- Schott, Heinz G. (1981). “Traumdeutung” und “infantile Cerebrallähmung.” Überlegungen zu Freuds Theoriebildung. *Psyche*, 35, 97–110.
- Spehlmann, Rainer. (1953). *Sigmund Freuds neurologische Schriften*. Berlin-Heidelberg-Göttingen.

---

## **KNOT**

Jacques Lacan used a topological structure of the knot to define the relationship of the symbolic, the real, and the imaginary.

In particular, he referred to the structure of rings on the coat of arms of the Borromei family. After introducing this notion on February 9, 1972, in his seminar “... ou pire” (... or worse), he made the knot a central focus of his theory.

In mathematical terms, a knot is a simple closed curve (Jordan's curve). Lacan mainly considered two nodal structures (Figure 1):

- The Borromean Knot: three component loops joined together in such a way that when one loop is cut the other two are no longer connected;
- The clover-leaf knot: the three components have been connected together into a single continuous loop.

For Lacan, the knot symbolizes the Imaginary. As an imaginary construct, it gives consistency to the

FIGURE 1

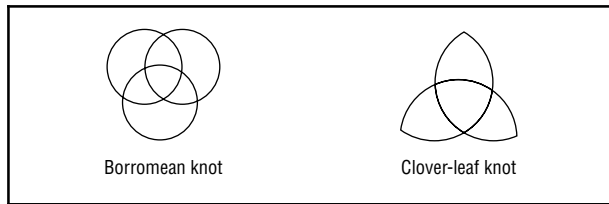

symbolic. Taken symbolically, the knot represents the undecidability of the real or imaginary.

The knot is an object located in space. A two-dimensional representation of it is made by means of crossings over or under. The knot's structure is determined by what crosses over or under what. However, the knot's structure is not dependent on its representation. Indeed, it was to translate representation into structure that an algebraic writing system for knots was developed. This writing system was refined over the course of the twentieth century and gradually made it possible to distinguish among different types of knots. In this system, the knot's topological loops become letters (in the form of polynomials). This marks the fact that the knot originates in the lost letter.

In Lacan's spoken lectures, the knot functioned first and foremost as a piece of writing. This called into question of the relationship between speech and writing, and showed that "writeability" is essential to the formation of the unconscious (Sigmund Freud's "Letter 52" to Wilhelm Fliess). "The unconscious can only be expressed in knots of language" (Lacan).

HENRI CESBRON LAVAU

*See also:* Imaginary, the (Lacan); Philosophy and psychoanalysis.

### Bibliography

- Darmon, Marc. *Essais sur la topologie lacanienne*. Paris: Éditions de l'A.F.I., 1990.
- Freud, Sigmund. (1950a [1896]). Letter 52. Stratification of memory traces. *SE*, 1: 234–240.
- Lacan, Jacques. (1971–1972). *Le séminaire Livre XIX: ... Ou pire*. Unpublished.
- . (2002). The instance of the letter in the unconscious, or Reason since Freud. In *Écrits: A selection* (pp. 138–168). (Bruce Fink, Trans.). New York: W. W. Norton. (Original work published 1966)

## KNOWLEDGE OR RESEARCH, INSTINCT FOR

In a 1915 addendum to *Three Essays on the Theory of Sexuality* (1905d), Freud described the instinct for knowledge (or research) in these terms: "This instinct (*Wisstrieb* or *Forschertrieb*) cannot be counted among the elementary instinctual components, nor can it be classed as exclusively belonging to sexuality. Its activity corresponds on the one hand to a sublimated manner of obtaining mastery, while on the other hand it makes use of the energy of scopophilia (*Schaulust*)" (p. 194). This definition took into account his earlier essay "On the Sexual Theories of Children" (1908c). He thus envisioned the instinct for knowledge (or research) in terms of its instinctual composition (seeing and mastery) and in its continuation beyond childhood, when it originates.

Freud posited the instinct for knowledge as having two aspects, privileging form in one case and content or the object in the other. That an instinct for knowledge should exist seems paradoxical, since all instinct implies a movement toward its goal (discharge) but what is special about this instinct is the fact that its object is the search for knowledge—not the possession of a particular piece of knowledge, but the effort to obtain it. To the extent that this effort connotes work more than pleasure, and moreover, that this instinct is not innate, it is necessary to find its origin in another source, namely, the combination of two "component" instincts, scopophilia and the instinct for mastery. But the extension of the pleasure of seeing (*Schaulust*) to the instinct for research (*Forschertrieb*, *Wisstrieb*) requires that in this case "seeing" be understood not as contemplation but as critical scrutiny, the perception of a difference, a lack, or an absence. Similarly, the fact that the instinct for mastery (*Bemächtigungstrieb*) can enter into the composition of the instinct for knowledge, while the former stems from cruelty (*Grausamkeit*) and is expressed in destruction and in sadomasochistic reversal, means that the instinct for mastery has been diverted through sublimation. "All activities that rearrange or effect changes are to a certain extent destructive and thus redirect a portion of the instinct from its original destructive goal," Freud wrote to Marie Bonaparte on May 27, 1937 (E Jones, 1953–57, vol. 3, p. 464).

What the musculature achieves by immobilizing its object without destroying it, thought achieves by means of mastering its object through selective attention and method. In both cases, the subject itself is



also immobilized in the process. Just as sublimation is a reversible process that is never definitively achieved, obsessive rumination may flood the critical faculties (as in the attitude of the Wolf Man with regard to religious instruction), or, alternatively, inhibition in the form of doubt may condemn discursiveness to the void.

In *Three Essays on the Theory of Sexuality*, Freud asserted that what sets the instinct for knowledge into motion are practical concerns rather than theoretical interests. “The threat to the base of a child’s existence offered by the discovery or the suspicion of the arrival of a new baby and the fear that he may, as a result of it, cease to be cared for and loved, make him thoughtful and clear-sighted” (pp. 194–95). The instinct for mastery can be seen to originate in trauma, because the child believes itself to be in danger.

It was this viewpoint of the traumatic origin of thought activity that Sándor Ferenczi insisted upon; he even saw “pure intelligence” as a product of the process of the imminence of death (*Fragment*, August 7, 1931). Melanie Klein, on the other hand, because the instinct for knowledge involves investigating the contents of the maternal body, saw in it an attitude that was more predatory than defensive. Piera Aulagnier, for her part, emphasized in *Les Destins du plaisir. Aliénation, amour, passion* (The vicissitudes of pleasure: alienation, love, passion; 1979) that the I’s need to know its origins has to do with its need to effect in its own name the work of self-identification. In her view, the question “Where do children come from?” in fact refers to the subject itself, the parental desire that brought the subject into being, and the place where the subject was when not yet in the world. This question of origins is therefore inseparable from that of the possibility of no longer being in the world, and thus the death of the I (Sophie de Mijolla-Mellor, 1992).

With regard to the origins of reflection in primitive man, in “Thoughts for the Times on War and Death” (1915b) Freud indicated the value of this questioning about death especially when it affects a person who is partially loved, and thus with whom the subject can identify: “What released the spirit of enquiry in man was not the intellectual enigma, and not every death, but the conflict of feeling at the death of loved yet alien and hated persons” (p. 293). One can extend to children this origin of the thetic position of the enigma rooted both in the ambivalent feelings (characterized by Mijolla-Mellor as “the giving way of the ground of

what seems to be”) about the child’s presentiments about parental sexuality (“enigmatic signifiers,” in the words of Jean Laplanche) and, more radically, about the child’s dawning awareness, when siblings are born or in some other way, of the fact that he or she has not always existed and will not always exist.

SOPHIE DE MIJOLLA-MELLOR

*See also:* Infantile sexual curiosity; Infant observation; (therapeutic) Instinct; Intellectualization; *Learning from Experience*; *Leonardo da Vinci and a Memory of His Childhood*; Need for causality; “On the Sexual Theories of Children”; Passion; Sexual theories of children; Thought.

### Bibliography

- Aulagnier, Piera. (1979). *Les Destins du plaisir. Aliénation, amour, passion*. Paris: Presses Universitaires de France.
- Ferenczi, Sándor. (1949). Notes and fragments (1930–32). *International Journal of Psychoanalysis*, 30, 231–242.
- Freud, Sigmund. (1905d). Three essays on the theory of sexuality. *SE*, 7: 123–243.
- . (1908c). On the sexual theories of children, *SE*, 9: 205–226
- . (1915b). Thoughts for the Times on War and Death. *SE*, 14: 273–300.
- Jones, Ernest. (1953–57). *Sigmund Freud: Life and work*. London: Hogarth.
- Klein, Melanie. (1948). *Contributions to psychoanalysis*. (1967). London: Hogarth Press.
- Laplanche, Jean. (1989). *New foundations for psychoanalysis*. Cambridge, MA: Basil Blackwell.
- Mijolla-Mellor, Sophie de. (1992). *Le plaisir de pensée*. Paris: Presses Universitaires de France.

### Further Reading

- Friedman, Lawrence. (1968). Drives and knowledge: a speculation. *Journal of the American Psychoanalytic Association*, 16, 81–94.

---

## KOCH, ADELHEID LUCY (1896–1980)

Physician and psychoanalyst Adelheid Lucy Koch was born on October 16, 1896, in Berlin and died on July 29, 1980, in São Paulo, Brazil. German by birth and Jewish by ancestry, she became in later life a Brazilian citizen.

Koch studied medicine at the University of Berlin and joined the Berlin Psychoanalytic Society after undergoing four and a half years of analysis with Otto Fenichel.

In São Paulo, a group of physicians and non-physicians interested in psychoanalysis had gathered around Durval Marcondes in the 1920s, leading to the creation of the *Revista Brasileira de Psicanalyse* (Brazilian Review of Psychoanalysis). Although this journal did not continue beyond its first issue, the influence of psychoanalytic ideas extended both to clinical practice and to Brazilian cultural life. Brazil's social and cultural elite closely followed the evolution of European analytic movements, but there was a palpable lack of clinical experience or serious analytic training.

The well-known Berlin Polyclinic served as a model for the psychiatrist Durval Marcondes, whose insistent requests for help addressed to Ernest Jones led Jones, in 1936, to recommend Adelheid Koch, who at the time intended to emigrate there. Compelled to leave Nazi Germany, she began work as a training analyst in São Paulo in 1937. She taught the first cohort of Brazilian analysts, including Marcondes, Virginia Leone Bicudo, Ligia Amaral, Frank Philips, and Flávio Dias. In addition to didactic analyses, Koch conducted seminars and served as a control analyst.

With Koch at its head, the Brazilian group obtained official status in 1944, under the name of Psychoanalytic Group of São Paulo. In 1951, the group joined the International Psychoanalytic Association as the Brazilian Psychoanalytic Society of São Paulo.

Adelheid Koch continued to conduct didactic analyses and seminars until her death.

LEOPOLD NOSEK

*See also:* Brazil.

### **Bibliography**

Nosek, Leopold, et al. (1994). *Álbum de família: imagens, fontes e idéias da psicanálise em São Paulo*. São Paulo: Casa do psicólogo.

## **KOHUT, HEINZ (1913–1981)**

The psychoanalyst Heinz Kohut was born in Vienna on May 13, 1913, and died in Chicago on October 8, 1981. Kohut was an only child. His father, Felix Kohut, a businessman, was a soldier on the Russian front

during the First World War. Kohut was very close to his mother, Else Lampl, and his maternal grandfather. Kohut's parents were Jewish, but his mother had been baptized a Christian and had taken her first communion. Kohut's childhood was filled with sadness and solitude. The family climate was cold and distant, and his parents were often busy. He had a personal tutor for studying the classics. His teachers, especially a teacher of history and geography, often served as role models. He dedicated his book *Analyse et Guérison* (Analysis and cure) to his tutor and to his history teacher. At the age of nineteen he began studying medicine. In 1936 he spent a year in Paris and in 1938 became a doctor of medicine.

Kohut was analyzed by Walter Marseilles, then by August Aichhorn, whose openness and skill he praised. Known to offer delinquents a magnified image of their ego ideal, Aichhorn had his own ideas about narcissism. With the rise of the Nazis, Kohut was forced to go into hiding and left Vienna shortly after Sigmund Freud.

Kohut traveled to Great Britain, where he was placed in a camp for immigrants before going to live with his maternal uncle. He left for the United States and in 1940 arrived in Chicago, where his friend Sigmund Levarie was living. He began a training analysis with Ruth Eissler, became a neurologist in 1944, became a psychiatrist in 1947, and also underwent training in analysis at the Chicago Institute for Psychoanalysis, from which he received a diploma in 1948. He married Betty Meyer, a social worker at the institute who had been analyzed in Vienna before the war and had participated in a training seminar with Aichhorn. Betty later went into practice for herself as a therapist. Their only child, Thomas August, named in honor of August Aichhorn, with whom Kohut had maintained a correspondence over the years, became a psychohistorian and wrote a book on William II, taking inspiration from his father's theories.

A member of the American Psychoanalytic Association, Kohut became a full member in 1953 and president in 1964. He was vice president of the International Psychoanalytical Association from 1965 to 1973. These professional activities earned him the sobriquet "Mr. Psychoanalysis." He overhauled the Chicago Institute of Psychoanalysis, freeing it from the influence of Franz Alexander. He drew attention to the benefits of selecting different kinds of candidates, including nonphysicians, to avoid conformity and

promote creativity. He explained that his interest in narcissism originated in the observation of his own misbehavior within various psychoanalytic societies. He felt that members' attitudes went far beyond professional rivalry and aggression, and included elements of contempt and a lack of respect for others.

Kohut (1990–1991a) defined empathy as a key element of analysis, a viewpoint he maintained and extended throughout his life. “Forms and Transformations of Narcissism” (1966) and “The Psychoanalytic Treatment of Narcissistic Personality Disorders” (1990–1991b) introduced a new way of analyzing narcissism that culminated in the publication of *The Analysis of the Self* (1971) and *How Does Analysis Cure?* (published posthumously in 1984), Kohut's major works on his new psychology of the self. “The Two Analyses of Mr. Z” (1990–1991d) relates the history of an analysis by Kohut and describes his theoretical and clinical development.

Kohut's thought had considerable impact in the United States, and he has received widespread discussion in the psychoanalytic literature. His ideas have influenced not only his followers but also his adversaries. His importance can be compared to that of Jacques Lacan in France. He has had less impact internationally, however, and his influence varies from country to country. Narcissistic transference has been widely recognized, notwithstanding disagreement over the method of treating narcissism, but his new metapsychology was never widely accepted. Kohut's successors have organized annual conferences and established training institutes, but they have also distanced themselves from him to develop the insights that Kohut introduced in a more personal vein.

AGNÈS OPPENHEIMER

*Notions developed:* Action-thought (H. Kohut); Alter ego; Bipolar self; Compensatory structures; Disintegration products; Fragmentation; Grandiose self; Idealized parental imago; Idealizing transference; Mirror transference; Narcissistic rage; Narcissistic transference; Progressive neutralization; Self-object; Self psychology; Self, the; Splitting, vertical and horizontal; Transference of creativity; Transmuting internalization; Twinship transference/alter ego transference.

*See also:* Act/action; Analyzability; Boredom; Borderline states; Disintegration, feelings of, (anxieties); Identity;

Libido; Narcissism; Narcissistic injury; Object; Paranoia; Purified-pleasure-ego; Self; Self-image; United States.

### **Bibliography**

- Kohut, Heinz. (1966). Forms and transformations of narcissism. *Journal of the American Psychoanalytic Association*, 14, 243–272.
- . (1971). *The analysis of the self*. New York: International Universities Press.
- . (1977). *The restoration of the self*. New York: International Universities Press.
- . (1984). *How does analysis cure?* Chicago: University of Chicago Press.
- . (1990–1991a). Introspection, empathy, and psychoanalysis: an examination of the relationship between mode of observation and theory. In his *The search for the self* (Vol. 1, pp. 205–232). New York: International Universities Press. (Original work published 1959.)
- . (1990–1991b). The psychoanalytic treatment of narcissistic personality disorders. In his *The search for the self* (Vol. 1, pp. 477–509). New York: International Universities Press. (Original work published 1968.)
- . (1990–1991c). Thoughts on narcissism and narcissistic rage. In his *The search for the self* (Vol. 2, pp. 615–658). New York: International Universities Press. (Original work published 1972.)
- . (1990–1991d). The two analyses of Mr. Z. In his *The search for the self* (Vol. 4, pp. 395–446). New York: International Universities Press. (Original work published 1979.)

## **KOREA**

Since Korea was occupied by Japan during the period 1910 to 1945, it has looked to that country for its models of psychiatric thought, which, from that time, have been largely organically based descriptions. The earliest known Korean analyst was Sung Hee Kim, who trained under Kosawa Heisaku in Japan from 1940–45. He returned to Korea to become professor of psychiatry at Chonham University Medical School but did not initiate a local training program. This came later, after the Korean War, which brought American psychiatrists to Korea who taught depth psychology. That, together with the return of a few of the many Korean doctors who had gone to the United States to study psychiatry, led to the introduction of psychoanalysis as a formal system of thought.

However, prevailing systems of thought had already given rise to a set of cultural practices which have their own preventative and curative effects on individuals in times of distress (Chang and Kim, 1973). These included Shamanism and its concomitant belief that man's misfortune results from an improper relation to the spirit world. A qualified mediator or *mutang* performs the ritual of the *goot* through which relations are harmonized. Prior sufferers become qualified as shamans through their close rapport with spirits and their children are said to inherit these abilities. There is also a long tradition of folk medicine, consisting of herbal remedies, acupuncture, and *moxa*, all introduced from China and still prevalent today.

In seeking help, Korean patients are like those in other Asian countries in seeking multiple treatments for a single complaint, and they tend to somatize psychological problems (see Psychoanalysis and China, this volume). In attempting to develop a culturally relevant approach to psychotherapy the pioneering analysts devoted a good deal of their time to studying traditional cultural practices (religions, myths, folk dramas, and literature) from the viewpoint of orthodox theory.

One outcome of this endeavour was a revision of Freud's conception of the Oedipus complex, such that its resolution involves sublimation of incestuous wishes to *hyoa*, the Korean term for filial piety. This is based upon a reciprocity between generations such that respect accorded by the children is balanced by the understanding and responsibility of the parents (Kim, 1978). Another project has made use of the prevalence of Taoist beliefs about illness being due to an excess of exertion in thought or action. This has led some neo-Freudian analysts to develop a "Taoistic psychotherapy" which emphasizes an acceptance rather than a refusal of one's inner conflicts, and transcends them by training the mind towards a more positive outlook (Kim, 1996).

Not until the 1970s did Korean clinicians seek formal ties with the International Psychoanalytic Association. Cho Doo-Young, trained at Cornell and New York, organized the Korean Psychoanalytic Study Group which has since developed into the Korean Psychoanalytic Study Group. It is orthodox Freudian in orientation and has about 50 members. Two other organizations, the Korean Academy of Psychotherapy (neo-Freudian and Taoist with about 80 members) and the Korean Association of Jungian Psychology (with 30 members), are actively pursuing a culturally relevant psychoanalytic practice.

Since the 1980s, orthodox psychoanalytic interests in Korea have diminished, in line with other parts of the world, in the wake of a rising interest in biologically based explanations of psychological disturbance. A lack of Korean training has meant that those interested in being trained have had to go abroad, where the differences in language and cultural understanding have traditionally (in the West) been viewed as resistance but which might become the wellspring for future developments in cultural psychoanalytic theory (Fisher, 1996).

GEOFFREY H. BLOWERS

### **Bibliography**

- Chang, S.C. and Kim, K.I. (1973). Psychiatry in South Korea. *American Journal of Psychiatry* 130, 6. 667–669.
- Fisher, Charles P. (1996). Panel Report: Psychoanalysis in the Pacific Rim. *International Journal of Psychoanalysis*, 77, 373–377.
- Kim, K.I. (1978). The Oedipus complex in our changing society; with special reference to Korea. *Neuropsychiatry* (Seoul) 7(1), 97–103.
- . (1996). Traditional therapeutic issues in psychiatric practice in Korea. Paper read in a Transcultural Psychiatry symposium of the Xth World Congress of Psychiatry, August 23.

---

### **KOSAWA, HEISAKU (1897–1968)**

Heisaku Kosawa, a psychoanalyst who laid the foundation of psychoanalysis in Japan, was born on July 17, 1897, in Atsugi, Kanagawa Prefecture, and died on October 5, 1968, in Tokyo. In 1926 he graduated from the School of Medicine of Tohoku University, where he studied under Professor Kiyoyasu Marui. And he became associate professor of psychiatry there in 1931.

From 1932 to 1933 he studied at the Vienna Psychoanalytic Institute, where he received training analysis from Richard Sterba and supervision from Paul Federn. During his stay in Vienna, Kosawa visited Freud at the latter's home at Bergasse 19 and presented a paper written in German entitled "Two kinds of guilt feelings." The paper explained his theory of the Ajase complex, which he contrasted with Freud's Oedipus complex. Moreover, he attended the twelfth congress of the International Psychoanalytical Association in Wiesbaden—the first Japanese to do so. There he met Heinz Hartmann and Karl Menninger, who became

his close friends. After returning to Japan in 1934, he opened a private clinic in Tokyo. Until his death in 1968, he remained the only Japanese to practice psychoanalysis before and for a while after World War II.

While helping to publish the Japanese translation of a collection of Freud's works, Kosawa himself translated into Japanese Freud's *Neue Folge der Vorlesungen zur Einführung in die Psychoanalyse* (*New Introductory Lectures on Psycho-Analysis*) and published it in 1953. At around the same period, he began performing training analyses on Japanese psychiatrists and psychologists. In 1955 he established the Japan Psychoanalytic Society and served as its president until 1957.

Kosawa noticed that, compared with patients in Europe and America, Japanese patients tended to regress easily to the level of a mother-child relationship, and that the fundamental conflict often seen in such relationships was the child's ambivalence toward the mother. This led to his theory of the Ajase complex. Underlying this theory is Kosawa's Buddhist views of life and people.

Throughout his life Kosawa was committed to instructing his students directly through training analyses and supervisions, and he preferred not to publish papers and literary works himself. Thus, there are few works that can be regarded as his representative literary productions. However, he is credited for having trained some of Japan's leading mainstream psychoanalysts who were instrumental in promoting psychoanalysis, dynamic psychiatry, clinical psychology, and psychosomatic medicine in postwar Japan.

KEIGO OKONOJI

*Notion developed:* Ajase complex.

*See also:* Complex; Japan.

### **Bibliography**

Okonogi, Keigo. (1995). A history of psychoanalysis in Japan. In Peter Kutter (Ed.), *Psychoanalysis international: a guide to psychoanalysis throughout the world* (Vol. 2). Stuttgart–Bad Cannstatt, Germany: Frommann-Holzboog.

## **KOURETAS, DEMETRIOS (1901–1984)**

Demetrios Kouretas, Greek psychiatrist and psychoanalyst, was born on July 8, 1901, in Chrysovitsi (a small village in Arcadia) and died in Athens on May 14, 1984. Kouretas was reared in Tripoli in Peloponnisos. He

began his university studies in Athens and continued them at the École de médecine de Lyon, then in Paris at the Salpêtrière and the Val-de-Grâce hospitals. On returning to Greece he worked as a neuropsychiatrist in various military hospitals, and in 1933 he was elected associate professor in the medical faculty of the University of Athens. In 1942 he was appointed to the chair of psychiatry and neurology at Salonika University, from which he resigned six years later. In 1964 he occupied the chair of psychiatry at the University of Athens.

His analytic career began by being analyzed by Andreas Embirikos and continued with a brief analysis by Marie Bonaparte (1949–1950?). He was a member of the first Greek psychoanalytic group, organized around Bonaparte in 1947, and in 1950 he was elected a full member of the Société psychanalytique de Paris (Paris Psychoanalytic Society). After the dissolution of the first Greek psychoanalytic group in 1951, Marie Bonaparte conducted a regular correspondence with him for several years. Through his university positions, Demetrios Kouretas influenced young physicians, yet he always continued to work privately as an analyst.

Kouretas's articles and books on clinical psychoanalysis and mythology enjoyed a large audience in Greece. They dealt with the theory and practice of psychoanalysis, and also with applied psychoanalysis, such as his study of the "Io complex" in Aeschylus's *The Suppliants* and *Prometheus Bound* (1949) and "The Actual Neuroses of the Danaïdes" (1957).

ANNA POTAMIANOU

*See also:* Greece.

### **Bibliography**

Kouretas, Demetrios. (1949). Le complexe d'Io dans "Les suppliantes" et le "Prométhée enchaîné" d'Eschyle. *Revue française de psychanalyse*, 13 (3), 445–460.

———. (1957). Psychanalyse et mythologie: la névrose actuelle des Danaïdes. *Revue française de psychanalyse*, 21 (4), 597–602.

Tzavaras, Athanase. (1984). *La psychanalyse et la Grèce*. Athens: Société d'études de la culture néohellénique et de l'éducation.

## **KOVÁCS-PROSZNITZ, VILMA (1883–1940)**

Vilma Kovács-Prosznitz, the Hungarian psychoanalyst, was born at Szeged in Hungary on October 13, 1883, and died in Budapest in May 1940.

She was the third daughter of a provincial bourgeois family and her father died while she was still very young, less than six years old. The family found itself destitute, and Vilma was married at the age of fifteen and against her will to a cousin, Zsigmond Székely, who was twenty years older than she. By the age of nineteen she was the mother of three children. Alice, the eldest, later married Michael Balint. Vilma contracted tuberculosis and had to spend prolonged periods in a sanatorium. It was there that she met Frédéric Kovács, an architect, whom she married after a difficult divorce that separated her from her children for several years. The children joined Vilma and her husband shortly before World War I and were adopted by Frédéric Kovács after their father's death. A serious case of agoraphobia led Vilma into analysis with Sándor Ferenczi. He was quick to spot his patient's talents and during the 1920s he trained her as a psychoanalyst, making her one of his closest collaborators.

In 1925, Vilma Kovács became head of the training committee. A highly reputed training analyst, she organized the Hungarian Psychoanalytic Association's clinical seminars and along with Sándor Ferenczi she elaborated the Hungarian training method: the candidate's analyst supervises the candidate's first case on the couch. As patrons of psychoanalysis in Hungary, in 1931 Vilma and her husband financed the Psychoanalytic Polyclinic at 12 Mészáros Street, in a building that belonged to them.

Vilma Kovács's work related essentially to training. Practically every Hungarian analyst of her time frequented her clinical seminars at one time or another. More specifically, she analyzed Imre Hermann and Géza Róheim.

She published only five articles, but one of them, "Training Analysis and Control Analysis" (1935), is a classic of psychoanalytic literature and has been translated into several languages.

In another article, "Examples of the Active Technique," dating from 1928, she provides a remarkably clear presentation of this technique that her mentor, Sándor Ferenczi, had just introduced, illustrating it with several examples.

Through her clear-mindedness, her remarkable clinical sense, and her organizational skills, Vilma Kovács left a profound mark on the Hungarian school of psychoanalysis.

JUDITH DUPONT

See also: Bálint-Székely-Kovács, Alice; Hungarian School; Hungary.

### Bibliography

- Kovács, Vilma. (1925) Ein Fall von "tic convulsif." *Internationale Zeitschrift für Psychoanalyse*, 11 (3), 318–324.
- . (1926) Das Erbe des Fortunatus. *Imago*, 12, (2–3), 321–327.
- . (1928) Beispiele zur aktiven Technik. *Internationale Zeitschrift für Psychoanalyse*, 16 (3), 405–408.
- . (1931) Wiederholungstendenz und Charakterbildung. *Internationale Zeitschrift für Psychoanalyse*, 17 (4), 449–463.
- . (1935) Lehranalyse und Kontrollanalyse. *Internationale Zeitschrift für Psychoanalyse*, 21 (4), 515–524.
- . (1936). Training and control-analysis. *International Journal of Psycho-Analysis*, 17 (3), 346–354.

---

## KRAUS, KARL (1874–1936)

Karl Kraus, an Austrian writer, was born April 28, 1874, in Bohemia and died in Vienna on July 12, 1936.

He was the ninth child of the businessman and manufacturer Jakob Krauss and his wife Ernestine. The family moved to Vienna in 1877. Kraus became interested in the theater while still quite young. He studied law, philosophy, and German, and worked as a critic for several magazines; he published an essay in 1897 in which he denounced the excesses of fin-de-siècle decadence (Gustav Klimt) and attacked his friend Hugo von Hofmannsthal. In 1910 the first reading of Kraus's work was held in Berlin. This was followed by approximately seven hundred other readings in different European cities, where the work of other authors was read—William Shakespeare, Johann Nestroy, Frank Wedekind, Jacques Offenbach—some of which had been translated and adapted by Kraus.

Kraus converted to Catholicism in 1911 but abandoned the religion in 1923. In 1913 he had an affair with Sidonie Nadherny von Borutin, which was cut short by her marriage in 1920. She left the marriage six months later to join Kraus. In 1933 he wrote a text critical of Hitler that was published only after his death, but a poem of his clearly indicated his position. In 1936 he was struck by a cyclist and died on July 12.

His writing first appeared in *Die Fackel* (The Torch), which he founded and managed by himself from 1899 to 1936. Kraus examined the “small things” of everyday life, which he elevated into a general criticism of corruption and social conformity, especially that of the press, whose influence was growing. Kraus, in his criticism, was ambiguous about the question of Judaism, and in it he expressed what Otto Weininger referred to as hatred of the Jewish self. His pacifism, before and during the First World War, resulted in various forms of censorship. His “faith in language,” a language he tried to master, was a constant factor: “Language is the mother of thought, not its servant.”

Freud was one of the readers of *Die Fackel* around 1903, and mentioned it for the first time in 1905 in relation to his *Three Essays on the Theory of Sexuality*. In 1906 Kraus took part in the accusation of plagiarism launched by Wilhelm Fliess. Freud, who thought he saw an ally in Kraus, tried to meet him. The tone changed in 1910, however, after Fritz Wittels, who had been a prolific collaborator at *Die Fackel* but had left the magazine, gave a presentation before the Vienna Psychoanalytic Society entitled the “Neurosis of *Die Fackel*.” In his paper he caricatured Kraus’s aversion to the *Neue Freie Presse* as the expression of a death wish against the father. When Kraus learned of Wittel’s talk, he let loose the slings of his barbed wit against psychoanalysis itself.

ERIK PORGE

See also: *Fackel, Die; Wittels, Fritz (Siegfried)*.

### **Bibliography**

Kraus, Karl (1975). *Cahier Karl Kraus*. Paris: L’Herne, Cahiers de l’Herne.

———. (1985). *Pro domo et mundo*. Paris: Gérard Lebovici.

———. (1986). *La nuit venue*. Paris: Gérard Lebovici.

Nunberg, Hermann, and Federn, Ernst. (1962–1975). *Minutes of the Vienna Psychoanalytic Society*. New York: International Universities Press.

Porge, Erik. (1994). *Vol d’idées?*. Paris: Denoël.

Waldvogel, A. (1990). Karl Kraus und die Psychoanalyse. Eine historisch-dokumentarische Untersuchung. *Psyche—Zeitschrift für Psychoanalyse und ihre Anwendungen* 1990, 44 (5), 412–444.

Timms, Edward. (1986). *Karl Kraus, Apocalyptic satirist: Culture and catastrophe in Habsburg Vienna*. New Haven and London: Yale University Press.

## **KRIS, ERNST (1900–1957)**

Ernst Kris, an American psychoanalyst and art historian, was born on April 26, 1900, in Vienna and died on February 27, 1957, in New York. He was the son of Leopold Kris, a Jewish lawyer, and Rosa Schick. During and even before his studies at school, he became interested in art and art history. In 1918 he enrolled in the philosophy department at the University of Vienna and graduated in 1922 with a degree in art history. His dissertation was published in 1926 as *Der Stil “Rustique”* (Rustic Style). That same year he was appointed curator at the Museum of the History of Art in Vienna. His fiancé, Marianne Rie, introduced him to Freud in 1924 as an expert for his collection of antiquities. The Freud and Rie families were close friends: Oskar Rie, a pediatrician, was one of Freud’s tarok partners and also a member of the Vienna Psychoanalytic Society.

When Marianne Rie, after finishing her medical studies, began training in analysis in Berlin, Freud recommended analysis for Kris too. Kris completed his psychoanalytic training in Vienna with Helene Deutsch as his training analyst. In 1928, a year after their marriage, Ernst and Marianne Kris were made associate members of the Vienna Psychoanalytic Society.

Aside from his psychoanalytic practice, Kris worked as an art historian and published articles on art history. In 1929 he was appointed chief European expert for cameos and gems at the Metropolitan Museum of Art in New York to help catalog their new collection. As a psychoanalyst, he made important contributions to the psychology of the artist and the psychoanalytic interpretation of works of art and caricature. In the review *Imago* he published his first psychoanalytic study, “Ein geisteskranker Bildhauer” (A mentally ill sculptor) on Doctor Franz Xaver Messerschmidt. In 1932 he became coeditor of the review with Robert Waelder.

In 1933 Kris became an affiliate member of the Vienna Psychoanalytic Society, and in 1936 a delegate to the education committee. After the annexation of Austria by Germany, Kris was able to escape to London with his family. There he became a member of and training analyst with the British Psycho-Analytical Society, and he worked with the BBC on the scientific analysis of Nazi propaganda.

After 1940 he continued this propaganda work in Canada and the United States, where he settled in New York. In September 1940 he was appointed professor

at the New School for Social Research and began, with Hans Speier, a research program on totalitarian propaganda. In 1943 Kris became a member of the New York Psychoanalytic Society and began teaching at the New York Psychoanalytic Institute. In his long collaboration with Heinz Hartmann and Rudolph Loewenstein in the United States, he made essential contributions to the development of ego psychology. His longitudinal study on early infancy, done at the Child Study Center of Yale University, has remained famous. In 1945 he cofounded, and became coeditor of, the journal *The Psychoanalytic Study of the Child* and, with Anna Freud and Marie Bonaparte, edited the first edition of Freud's letters to Wilhelm Fliess.

ELKE MÜHLEITNER

*See also:* Ego; *Ego and the Mechanisms of Defence*, *The; Gesammelte Werke*; Kris-Rie, Marianne; Lehrinstitut der Wiener Psychoanalytischen Vereinigung; *Psychoanalytic Study of the Child*, *The*; Shakespeare and psychoanalysis; United States; Visual arts and psychoanalysis.

### **Bibliography**

Kris, Ernst. (1952). *Psychoanalytic explorations in art*. New York: International Universities Press.

———. (1975). *Selected papers of Ernst Kris*. New Haven, CT: Yale University Press.

———. (1979). *Psychoanalytische Kinderpsychologie*. Frankfurt am Main, Germany: Suhrkamp.

Mühleitner, Elke. (1992). *Biographisches Lexikon der Psychoanalyse: die Mitglieder der psychologischen Mittwoch-Gesellschaft und der Wiener psychoanalytischen Vereinigung, 1902–1938*. Tübingen, Germany: Diskord.

---

## **KRIS-RIE, MARIANNE (1900–1980)**

Marianne Kris-Rie, the Austrian physician and psychoanalyst, was born in Vienna on May 27, 1900, and died in London on November 23, 1980.

Marianne Kris was the daughter of Oskar Rie and Melanie Bondy. Oskar Rie was a highly reputed pediatrician and a friend of Freud, with whom he published *Klinische Studie über die halbseitige Cerebrallähmung der Kinder* (Clinical Study of Cerebral Hemiplegia in Children, 1891a). Marianne's mother was Wilhelm

Fliess's sister-in-law, her older sister, Margarete, being married to Herman Nunberg.

Already a physician, Marianne Kris married Ernst Kris in 1927, and one year later they both became members of the Vienna Psychoanalytic Society. She worked in close collaboration with Anna Freud, who was also her friend. From 1925 to 1927, she did her psychoanalytic training in Berlin with Franz Alexander. She was analyzed by Freud.

Obliged to leave Vienna in 1938, after the Anschluss, she moved first in London, where she was a member of the British Psycho-Analytical Society, then to the United States, where she settled in New York in 1940, becoming a member of the New York Psychoanalytic Society in 1944. She worked mainly in child psychoanalysis and helped train child analysts. She collaborated with social workers and teachers in different social sectors and played an active role in training non-physician psychotherapists.

She became a member of the Western New England Institute for Psychoanalysis and, in 1965, she and other child analysts contributed to creating the Association for Child Psychoanalysis, becoming its first president in the same year. She established the practice of working with the family when treating children and in 1972 she delivered a paper in New York on "The Psychoanalytic Study of the Family." She was also chief editor of the review *The Psychoanalytic Study of the Child*. She worked hard to have non-physicians admitted to psychoanalytic societies. She had two sons, and lost her husband in 1957. Marianne Kris died on November 23, 1980, in Anna Freud's house, having gone to Great Britain to take part in the second International Seminar of the Hampstead Clinic.

ERNST FEDERN

*See also:* Freud, *the Secret Passion*; Kris, Ernst; Lehrinstitut der Wiener Psychoanalytischen Vereinigung; New York Psychoanalytic Institute; Rie, Oskar.

### **Bibliography**

Kris, Marianne. (1957). The use of prediction in a longitudinal study. *Psychoanalytic Study of the Child*, 12, 175–189.

———. (1983). Parents and siblings: Their mutual influences. *Psychoanalytic Study of the Child*, 38, 311–324.







## L AND R SCHEMAS

The L and R schemas are two of Lacan's didactic diagrams; they articulate the dual relation, between the imaginary (which is dualistic) and the symbolic, (which adds a third element).

Human beings are at first captured *in* the symbolic order before they are aware of it. They enter into it, through the parades of speech, as in the fort/da game that Freud described in *Beyond the Pleasure Principle* (1920g).

Schema L developed out of Lacan's study of Poe's story "The Purloined Letter" in his seminar of 1954–55. It depicts the "relation" of the subject with the absolute Other. As the arrows in the schema indicate, it is from the Other (i.e., the unconscious, the "treasure trove of signifiers") that a message reaches the subject in an inverted form.

**FIGURE 1**

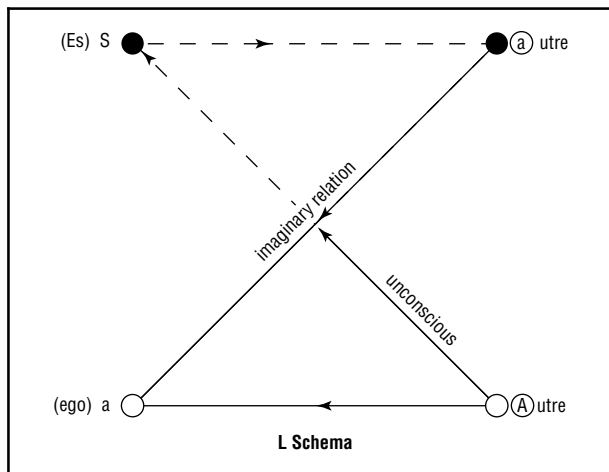

This message makes the subject "fade" when it is received (Figure 1).

In other words, the "relation" of the unconscious subject to the Other—that is, the relation the subject has with his or her own unconscious—is precarious and uncertain. In fact, it is always mediated by the subject's ego, which, according to Lacan's theory of the mirror stage, is based on the image of another. Thus, if we ignore the direction of the arrows, communication between S and A can only follow a trajectory that moves from other people—that is, the "small other"—to the subject's ego, that is, from the specular image to one's body image. These two are trapped in a Hegelian dialectic.

In "On a Question Prior to Any Possible Treatment of Psychosis" (1959), Lacan produced schema R, which extended and completed schema L. A distortion of schema R then produced schema I, which represents psychosis. And it is schema R in the form of a diamond that gives us the formula of fantasy:  $\$ \diamond a$  (Figure 2).

This quadrangular schema represents the Oedipus complex in two different aspects, imaginary and symbolic. The square includes on the one hand the imaginary triangle mother-child-phallus, and on the other hand the symbolic triangle that structures the oedipal trio of father-mother-child.

The real is located between these two triangles. It is represented as a Moebius strip that simultaneously separates and unites the imaginary and the symbolic.

The relations of the terms on the outside of the square (M, mother; P, *père*, father; I, ego-ideal;  $\phi$ , phallus) along with those from schema L placed on the inside of the schema (S, *a*, *at*, A) are in the register of identification. This is how "The third term of

**FIGURE 2**

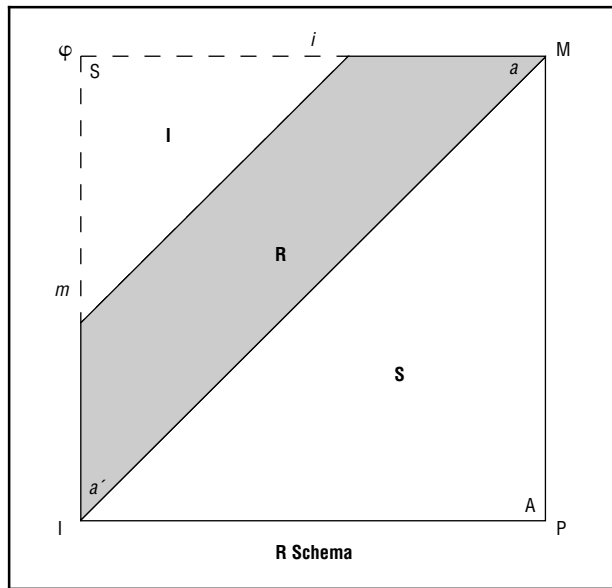

the imaginary ternary [mother-child-phallus]—the one where the subject is identified, on the contrary, with his living being—is nothing but the phallic image, whose unveiling in this function is not the least scandalous facet of the Freudian discovery” (Lacan, 2002, pp. 186–87).

The real in the center of the schema is in fact a Möbius strip, the edges of which are rejoined when the strip is cut out and twisted so that points *Mm* and *Ii* meet. This strip only sustains itself by extracting of object *a*: “It is thus as representation’s representative in fantasy—that is, as the originally repressed subject—that  $\$$ , the barred *S* of desire, props up the field of reality here; and this field is sustained only by the extraction of object *a*, which nevertheless gives it its frame” (Lacan, p. 213, n. 14).

In Schema I, the schema of psychosis, the phallic and paternal symbolic poles are completely distorted in favor of the imaginary relation *M-m* (Figure 3).

“[This] symbolizes . . . that the [psychotic’s] relation to the other qua relation to one’s semblable . . . [is] perfectly compatible with the skewing of the relation to the Other with a capital *O*” (Lacan, p. 204).

PATRICK DELAROCHE

See also: Four discourses; Graph of Desire; Matheme; Optical schema; Subject of the unconscious; Subject’s castration; Topology.

**FIGURE 3**

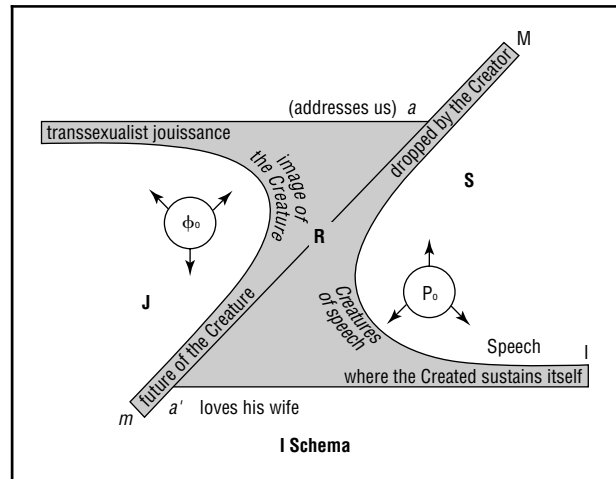

**Bibliography**

- Freud, Sigmund. (1920g) *Beyond the Pleasure Principle*. *SE*, 18: 1–64.
- Lacan, Jacques. (2002). On a question prior to any possible treatment of psychosis. In *Écrits: A selection* (Bruce Fink, Trans.). New York: W. W. Norton. (Original work published 1959)
- . (1988). *The Seminar of Jacques Lacan, Book II, The ego in Freud’s theory and in the technique of psychoanalysis (1954–1955)* (Sylvana Tomaselli, Trans.). New York: W. W. Norton.

**LACAN, JACQUES-MARIE ÉMILE (1901–1981)**

French psychiatrist and psychoanalyst Jacques-Marie Émile Lacan was born in Paris on April 12, 1901, and died on September 9, 1981, in the suburb of Neuilly.

He was born the eldest child of a bourgeois Catholic family of wealthy vinegar merchants from Orléans. Three other children followed: a boy who died young; Madeleine, born in 1903; and Marc, born in 1907, who would later become a Benedictine monk at Hautecombe. Lacan was close to his brother, both emotionally and intellectually, and owed his theological knowledge at least in part to him. Lacan completed his secondary studies at a well-regarded Catholic school, Stanislas College, where he was taught philosophy by Jean Baruzi, a specialist in Leibniz and the history of religion, especially St. John of the Cross.

At the beginning of the 1920s, Lacan began his medical studies while also frequenting the literary

centers of the avant-garde. Along with his friends Henri Ey and Pierre Mâle, he specialized in psychiatry and interned at Sainte-Anne Hospital under Henri Clude; Gaëtan Georges de Clérambault, his “only teacher in psychiatry” (Lacan, 1966, p. 65); and Georges Heuyer. He also served a stint at the Burghölzli Clinic from August to September 1929. In 1932, he defended his thesis, *On Paranoid Psychosis in its Relation to Personality*. The centerpiece of the thesis was the case of Aimée (whose name, he would later learn, was Marguerite Anzieu), a criminal psychotic whom he observed at Sainte-Anne. When it was published, the thesis caused a bit of a sensation and was praised by René Crevel and Salvador Dalí. In December 1933, Lacan published his article, “Motives of Paranoiac Crime,” in the journal *Minitaure*. The article was about the Papin sisters, whose crimes were then in the news and of great interest to the surrealists.

He entered analysis with Rudolph Loewenstein, probably in 1933 after completing his thesis. In 1934, he married Marie-Louise Blondin, the sister of his friend from medical school, Sylvain Blondin. The couple had three children, Caroline, Thibaut, and Sibylle. In the same year, he became a candidate member of the *Société psychanalytique de Paris* (SPP the Paris Psychoanalytic Society).

In 1936, at the fourteenth congress of the I.P.A. in Marienbad, Lacan presented what he called “the first linchpin of my contributions in psychoanalytic theory,” the text of which he claimed to have “neglected to deliver” for publication in the proceedings of the congress (Lacan, 1966, p. 67). The paper was called, “The Mirror State: The Theory of a Structural and Developmental Moment in the Construction of Reality, Conceived in Relation to Psychoanalytic Experience and Teaching,” a title that is known only from Lacan’s biography, written by Anatole de Monzie, in the *Encyclopédie française*. He delivered another version of the talk at the sixteenth IPA congress in Zurich in 1949: “The Mirror Stage as Formative of the *I* Function as Revealed in Psychoanalytic Experience,” an experience that was “at odds with any philosophy directly stemming from the *cogito*” (Lacan, 2002, p. 3). The ego, from Lacan’s point of view, was not the entire subject, nor the subject of consciousness, but the primary narcissistic imago. The ego was evidence of a “mad passion—specific to man, stamping his image on reality” (Lacan, 2002, p. 23), and it “repre-

sents the center of all resistances to the treatment of symptoms” (Lacan, 2002, p. 118). Thus in Lacan’s earliest formulations, the ego, far from being formed by reality, is opposed to it. Out of this early text came the opposition between psychological reality, external reality, and the real.

In December 1938, Lacan was elected a full member of the SPP. In the same year, he wrote an article on “The Family” for volume VIII of the *Encyclopédie française*, which was edited by Henri Wallon and devoted to “mental life.” It was published the following March. The formulations in this article, which was a reworking of Freudian theory, were already quite Lacanian.

During the war, two of his daughters were born. His first wife, who finally obtained a divorce in 1941, had Sybille in 1940. And in 1941, his companion Sylvia Bataille had his daughter Judith, who would marry Jacques-Alain Miller in 1966.

With his first post-war writing in 1945, “Logical Time and the Assertion of Anticipated Certainty,” Lacan continued with the investigation of the imaginary that he had begun in 1936, now focusing on “logical time” (as opposed to Eugène Minkowski’s “experienced time,” which Lacan had recently criticized in a review). Lacan argued that logical time manifested itself at the limit of the subject’s “time for comprehending,” when the subject was assured of an anticipated certainty in a “moment of concluding,” in other words, in an act (cf. Lacan, 1945/1988, p. 10). This text foreshadowed Lacan’s manipulation of time by varying the length of analytic sessions, which would become a source of controversy within the SPP and the IPA in the 1950s.

Lacan’s post-war years were also marked by an ongoing debate with psychiatry, starting with “On Psychic Causality,” a critique of his friend Henri Ey’s organo-dynamism written in 1946 for a conference at Bonneval on the problem of the origins of neurosis and psychosis. This was followed in 1947 by a lecture on “English Psychiatry and the War,” and in 1950 by a contribution to the first world conference on psychiatry, “A Theoretical Introduction to the Functions of Psychoanalysis in Criminology,” written with Michel Cénac.

At the same time, Lacan participated actively in the post-war rejuvenation of the SPP, and in 1949, he collaborated on the “Policies and Tenets of the SPP’s Committee on Teaching.”

In 1953, during his presidency of the Society, conflicts between medical analysts (Sacha Nacht) and more

liberal academic analysts (Daniel Lagache, Juliette Favez-Boutonier) led to the resignations of Françoise Dolto, Juliette Favez-Boutonier, Daniel Lagache, and Blanche Reverchon-Louve on June 16. Lacan quickly followed, and the group founded the *Société française de psychanalyse* (SFP, French Psychoanalytic Society) on June 18. On July 8, Lacan inaugurated the new society with a lecture “The Symbolic, the Imaginary, and the Real” (SIR), which began a new phase in his thought, marked by the prevalence of language and the symbolic over the imaginary, a concept that dated back to his elaboration of the imago and the mirror stage in 1936. He launched his return to Freud with this triad, which allowed him to differentiate between (symbolic) castration, (imaginary) frustration, and (real) privation, and also the symbolic father, the imaginary father, and the real father.

Nine days later, he married Sylvia Maklès, who had divorced Georges Bataille in 1946. In August he wrote “The Function of Speech in Psychoanalytic Experience and the Relation of Language to the Psychoanalytic Field,” the original title of the lecture that he had given in Rome on September 26, 1953. Each institutional stage in Lacan’s career, each crisis, served as the occasion for a significant crystallization of his thought and a theoretical advance that apparently helped him to define the moment. After the mirror stage, the “Rome Report” marked the second stage in his work.

The lecture on “The Symbolic, the Imaginary, and the Real” showed the influence of Claude Lévi-Strauss. The “Rome Report,” with its opposition between language and speech and its attention to ahistorical speech that goes beyond the intentions of its subject, coincided with some of the conceptions of Heidegger, whose article “Logos” Lacan had just translated. From his thesis in 1932 until 1953, Lacan read Freud’s texts in a nonsystematic way, and he differed from Freud in separating the ego from the perception-consciousness system in order to situate it in the imaginary, in accordance with his original conception of the mirror stage and the new elaboration he gave it in a 1951 lecture to the British Psychoanalytic Society, “Some Reflections on the Ego” (*I.J.P.*, 1953).

In the fall of 1953, his public seminar at the Sainte-Anne Hospital began a reevaluation of Freud’s work, much of which was only available in German or English: “This kind of teaching is a refusal of any system. . . . Freud’s thought is the most perennially open to revision” (Lacan, 1953–54, p. 1). He began this

revision with Freud’s writings on technique. Already in the still unpublished lectures that he held from 1950 to 1953, Lacan had approached psychoanalytic technique from own perspective of varying session length. His public seminar began with the question of resistance, which he attributed to an “organization of the ego” (1953–54, p. 23), while for Freud, resistance had to do with remembering.

The ongoing seminar at Sainte-Anne was ended on November 20, 1963, with a single session on what was to be his topic for 1963–64, *The Names-of-the-Father*. He gave this lecture the day after his “major excommunication,” the IPA’s refusal to grant him the status of training analyst, and it testified to the subjective and intellectual crisis that this rejection provoked in him. To consider the father, Lacan turned towards “religion, and [what] I, for my part, call the Church” (Lacan, 1963, p. 84). More specifically, he turned to *De Trinitate*, by St. Augustine.

The Seminar’s relocation to the École normale supérieure (ENS) in the rue d’Ulm in January 1964 brought about a noticeable change in its style and content. The audience was larger and more intellectual, and Lacan addressed himself particularly to the “Normaliens,” the students of the ENS until June 1969, when he was forced to leave the ENS. At the ENS, Lacan abandoned the “return to Freud” in order to develop his own thought and the foundations of psychoanalysis in his seminar *The Four Fundamental Concepts of Psychoanalysis* (the unconscious, repetition, transference, and the drive). During these years he formalized his own concepts: the barred subject,  $\$$ ; object  $a$ ; and the Other, which was both the Other of language and the Other scene, the scene of the dream and of the unconscious, a term that Freud borrowed from Fechner (cf. Freud, 1900a, pp. 48, 536).

On June 20, 1964, in the aftermath of his rejection by the IPA, Lacan “alone” founded the École française de psychanalyse (EFP, the French School of Psychoanalysis), which was soon renamed the École freudienne de Paris (Freudian School of Paris). The School saw a rapid increase in membership over its fifteen years of existence, growing from about 100 to more than 600 members.

In October 1966, Lacan made his first trip to the United States to attend a conference in Baltimore on structuralism. This conference took place shortly before the publication of his *Écrits*, a voluminous book of 924 pages in which all of his essential writings were collected.

*Écrits* allowed Lacan to win over the general public just as he had the Normaliens and the philosophers.

On November 26, 1969, Lacan began his seminar entitled *The Other Side of Psychoanalysis*, which was influenced by the student protests of May 1968, by introducing his “four discourses”: the discourses of the master, of the university, of the hysteric, and of the analyst. Each one was constructed out of four terms: S1, the master signifier; S2, knowledge; *a*, surplus enjoyment; and  $\$$ , the subject. The four discourses, or the “quadripode,” anticipated the matheme that Lacan introduced in December 1971, at a series of lectures given at Sainte-Anne Hospital on the “Knowledge of the Psychoanalyst.” He returned to this matheme in 1972 in his seminar *Encore* when he developed his graph of sexuation. According to Lacan, an algebraic mode of writing allowed for the transmission of psychoanalysis and removed the incompatibility between the discourse of analysis and the discourse of the university that was apparent in the four discourses. This argument gave Lacan grounds to sanction the expansion of psychoanalysis in the university.

His final orientation maintained the equivalence of the three coordinates. In the twenty-second year of his seminar, entitled *R.S.I.* (1973–1974), the symbolic, imaginary, and real were represented topologically by the Borromean knot, three rings connected in such a way that each held the two others in a circular reciprocity.

The end of Lacan’s life was sad, marked as it was by political and theoretical conflicts within the EFP and by rivalry between the School and the Department of Psychoanalysis at Vincennes, directed by his son-in-law Jacques-Alain Miller.

During the seminar on *Topology and Time* (1978–1979), Lacan was practically mute. Finally, in a moment of lucidity, he announced the dissolution of the School that he alone had founded in a signed letter dated January 5, 1980. In February, while awaiting the legal dissolution of the EFP (which eventually took place in September), he founded the *Cause freudienne* (the Freudian Cause), and then in October, he “adopted” the EFP as the new *École de la Cause freudienne* (School of the Freudian Cause).

Following the letter of dissolution, what Lacan called his “seminar” of January 15, 1980, was actually a series of sentences addressed to the newspaper *Le Monde* on January 26. “If it should happen that I go away, tell yourselves that it is in order—to be Other at last. One can be satisfied with being Other like everyone else, after

a lifetime spent being it in spite of the Law” (Lacan, 1980, p. 135). In fact, he was hospitalized under the name of his personal physician, and died of colon cancer at the Henri-Harman Surgical Center in Neuilly on September 9, 1981. His will, dated November 13, 1980, named Judith Miller his sole heir and his son-in-law Jacques-Alain Miller as his literary executor.

Throughout the century, Lacan met and spent time with the greatest minds of his era—Joyce, Kojève, Koyré, Dalí, Picasso, Bataille, Lévi-Strauss, Jakobson, Merleau-Ponty, Heidegger, and more. He had to endure the fact that no one really understood his work. His primary endeavor throughout his career was to find a theoretical basis for the speech of the analysand that leads to the transference and thus constitutes the analyst as Other. To try to find the basis for speech in anything other than itself is certainly a Faustian project, but it indicates his passion for analysis. Mallarmé’s assessment of Rimbaud suits Lacan as well: he was “a considerable passer-by.”

JACQUES SÉDAT

*Work discussed: Écrits*

*Notions developed:* Aimée, case of; Alienation; Parade of the signifier; Demand; Four discourses; Drive/instinct; Foreclosure; Formations of the unconscious; Graph of desire; I; Imaginary, the (Lacan); Imaginary identification/symbolic identification; Jouissance (enjoyment); Knot; L and R schemas; Law of the father; Letter, the; Matheme; Metaphor; Metonymy; Mirror stage; Name-of-the-Father; Object *a*; Optical schema; Other, the; Pass, the; Phallus; Real, the (Lacan); Real, Symbolic, and Imaginary father; Sexuation, formulas of; Signifier/signified; Signifying chain; Subject of the unconscious; Subject’s castration, the; Subject’s desire; Symbolic, the (Lacan); Symptom, sinthome; Thing, the; Topology; Unary trait; Want of being/lack of being.

*See also:* Adaptation; Autism; Automatism; Blank/nondelusional psychoses; Body image; Cinema (criticism); Colloque sur l’Inconscient; Congrès des psychanalystes de langue française des pays romans; Criminology and psychoanalysis; Cure; Dark continent; Deferred action; Delay, Jean; Disavowal; Ego ideal; Ego ideal/ideal ego; Ethics; Ey, Henri; Fantasy; Female sexuality; Feminism and psychoanalysis; Framework of the psychoanalytic treatment; France; Frustration; Identificatory project; Imago; *Infans*; Inhibition; *Jokes and Their Relation to the Unconscious*; Kantianism and psychoanalysis; Lagache, Daniel; Libido; Linguistics and psychoanalysis; Look, gaze; Lowenstein, Rudolph M.; Mouvement lacanien français; Nacht, Sacha Emanoel; Narcissism; Neurosis; Object; Object relations theory; Otherness; Philosophy and psychoanalysis; Phobias in children; Pichon, Édouard Jean Baptiste; Privation; Psychic causality;

*Psychanalyse, La*; Psychoanalyst; Psychoanalytic treatment; Psychoses, chronic and delusional; Quatrième Groupe (O.P.L.F.), Fourth Group; Repetition compulsion; Representative; Sainte-Anne hospital; Self-consciousness; Self-image; Self-representation; Sexual differences; Signifier; Société française de psychanalyse; Société psychanalytique de Paris et Institut de psychanalyse de Paris; Spinoza and psychoanalysis; Splits in psychoanalysis; Splitting; Training analysis; Structural theories; Structuralism and psychoanalysis; Subject; Symbol; Technique with adults, psychoanalytic; Wish/yearning; Word-presentation.

### **Bibliography**

- Dor, Joël. (1994). *Nouvelle Bibliographie des travaux de Jacques Lacan*. Paris: E.P.E.L.
- Freud, Sigmund. (1900a). The interpretation of dreams. *SE*, 4–5.
- Julien, Philippe. (1990). *Pour lire Jacques Lacan*. Paris: Seuil.
- Lacan, Jacques. (1966). *Écrits*. Paris: Seuil.
- . (1988, Fall). Logical time and the assertion of anticipated certainty: A new sophism (Bruce Fink, Trans.). *Newsletter of the Freudian Field* 2, 4–22. (Original work published 1945)
- . (1988). *The Seminar of Jacques Lacan, Book I, Freud's Papers on Technique (1953–54)* (John Forrester, Trans.). New York: Norton.
- . (1990). Introduction to the Names-of-the-Father. In John Copjec (Ed.), *Television: A challenge to the psychoanalytic establishment*. New York: W. W. Norton. (Original work published 1963)
- . (1990). The other is missing. In John Copjec (Ed.), *Television: A challenge to the psychoanalytic establishment*. New York: W. W. Norton. (Original work published 1963)
- . (2001). *Autres Écrits*. Paris: Seuil.
- . (2002). *Écrits: A selection* (Bruce Fink, Trans.). New York: W. W. Norton.
- Milner, Jean-Claude. (1995). *L'Œuvre Claire*. Paris: Seuil.

### **Further Reading**

- Mijolla, Alain de. (2001). Splits in the French psychoanalytic movement between 1953 and 1964. In R. Steiner and J. Johns (Eds.), *Within Time and Beyond Time, A festschrift for Pearl King* (pp. 1–24). London: Karnac. (Original work published 1995)

## **LACK OF DIFFERENTIATION**

The question of lack of differentiation is raised mainly from a topographical viewpoint, as well as that of the

founding of the psyche in infants. Interest in this topic has recently been renewed with the emergence of what is known as developmental psychoanalysis (Daniel N. Stern) and infant psychiatry. In general, the ontogenesis of the mental apparatus is intrinsically based on a model of two processes of differentiation: extrapsychic (or interindividual) differentiation and intrapsychic (or intrasubjective) differentiation. Extrapsychic differentiation gradually produces a demarcation between the “me” and the “not me.” Intrapsychic differentiation, meanwhile, leads to the functional organization of the different intrapsychic agencies (such as the id, the ego, and the superego). Obviously, these two processes take place in tandem and cannot be separated, except from a simple theoretical or pedagogical perspective, if only because discovery of the object is necessary to enable the subject to position him- or herself as a subject, and vice versa.

Lack of extrapsychic differentiation paves the way for psychotic (for example, autistic, symbiotic, or schizophrenic) modes of functioning in which there is a profound lack of distinction between inside and outside. It is also at the core of very archaic psychopathologies and, notably, of early childhood autism.

Thinking about lack of differentiation, based mainly on retrospective material that comes out in the treatment of children or adults (which provides access, within the dynamics of transference and countertransference, to an entire series of lived experiences and extremely early psychic mechanisms), was framed somewhat differently in the 1990s, owing to considerable developments as a result of studies of the dyad, the triad, and the entire range of early interactions between the baby and its environment.

Both Frances Tustin, with her theory of a “normal autistic phase” in development (which she herself later refuted), and Margaret Mahler, by describing an autistic phase prior to the later symbiotic phase within the “process of separation-individuation,” in their own respective ways created models with an initial period characterized by a lack of psychic differentiation.

Furthermore, several psychoanalytic authors have produced classic studies that have emphasized the very intense regime of reciprocal projections that initially exists between mother and baby (for example, Donald W. Winnicott’s “primary maternal preoccupation,” Wilfred R. Bion’s “capacity for maternal reverie” and “alpha function,” André Green’s theory of detour via the other, etc.).

Finally, other investigators have stressed the topographical unit that, from a somewhat phenomenological point of view, initially comprises the psyches of the baby and its parents together as a whole (Manuel Pérez Sánchez and Nuria Abello's "primal unit," Hanna Segal's "triangular space" and "third domain," etc.). This unit serves as a matrix for the infant's future symbolization.

The real question that has since arisen is whether an early phase of nondifferentiation really does exist. Perhaps, on the contrary, the baby—equipped with the many competencies now acknowledged in infants—possesses (extra- and intra-) psychic differentiation to a substantial degree to begin with. Stern, for example, cites the baby's early competencies in perception, memorization, and mental representation as evidence that there is no early, preparatory state in which differentiation is lacking. Élisabeth Pivaz's experimental model of the "triadic game" developed in Lausanne supports the same type of hypotheses.

In light of modern research in the very earliest stages of development, what is ultimately at issue is whether or not we are justified in hypothesizing an early dyadic or triadic topography and in specifying the modalities of the still enigmatic passage from the realm of the interpersonal to that of the intrapsychic.

BERNARD GOLSE

*See also:* Encounter; Feminism and psychoanalysis; Individual; Infant observation; Infant observation (direct); Infant observation (therapeutic); Isakower phenomenon; Projection and "participation mystique"; Symbiosis/symbiotic relation.

### **Bibliography**

- Mahler, Margaret, Pine, Fred, and Bergman, Anni. (1975). *The psychological birth of the human infant*. New York: Basic Books.
- Pérez Sánchez, Manuel, and Abello, Nuria. (1981). Unité originaire: Narcissisme et homosexualité dans les ébauches de l'oedipe. *Revue française de psychanalyse*, 45 (4), 777–786.
- Segal, Hanna. (1999). Le complexe d'Oedipe aujourd'hui. *Journal de la psychanalyse de l'enfant*, 24, 155–161.
- Stern, Daniel N. (1995). *The motherhood constellation: A unified view of parent-infant psychotherapy*. New York: Basic Books.
- Tustin, Frances. (1972). *Autism and childhood psychosis*. London: Hogarth.

## **LAFORGUE, RENÉ (1894–1962)**

René Laforgue, French psychiatrist and psychoanalyst, was born on November 5, 1894, in Thann, Alsace, then under German control, and died in Paris on March 6, 1962. He was the first president of the Société psychanalytique de Paris (Paris Psychoanalytic Society).

His mother, Eugénie Heitzmann, came from a large family that lived in the Vosges. His father, Joseph, a copperplate engraver for a cloth manufacturer, was an illegitimate child. Laforgue studied at the Collège de Thann, in Forbach, and in Fribourg, then with Franz Oppenheimer, a physiologist from Berlin. In 1913, while working with Oppenheimer, he came across a copy of Sigmund Freud's *The Interpretation of Dreams*. During the First World War he was mobilized in the German army and barely escaped death in the Carpathian mountains.

In 1919 Alsace again became French and Laforgue concluded his medical studies as an intern at the Hoerdtsch Psychiatrisch Hospital, where he studied under Professor Pfsdorff. In 1922, in Strasbourg, he defended his dissertation, "Étude sur l'affectivité des schizophrènes du point de vue psychanalytique." That same year he married Paulette Erickson, whom he met at the Theosophical Society.

He arrived in Paris in 1923 and went to work at the Sorbonne with Professor Henry on the physiology of sensation. He began a short analysis with Eugénie Sokolnicka. He then worked at the Sainte-Anne Hospital as an assistant. After being put in charge of psychoanalytic consulting under Henri Claude in place of his analyst, he and Edouard Pichon wrote an article for the October 20, 1923, issue of *Progrès médical* entitled "De quelques obstacles à la diffusion des méthodes psychanalytiques en France" (Certain obstacles to the diffusion of psychoanalytic methods in France). That same month he wrote to Freud for the first time. The following year he met him in Berchtesgaden. With Freud's support he was unanimously elected a member of the Vienna Psychoanalytic Society in 1925.

He was a co-founder, and co-editor with Angélo Hesnard, of the review *L'Évolution psychiatrique*, the first issue of which appeared in April 1925. Freud discussed Laforgue's article "La Schizonoïa," a critique of Otto Rank's theory of birth trauma and his concept of scotomization, which was nearly indistinguishable from repression.



Laforgue was the first president of the Société psychanalytique de Paris (Paris Psychoanalytic Society), which he helped found in November 1926. He remained president until 1930. He edited the medical section of the *Revue française de psychanalyse* with Angélo Hesnard from its inception in 1927. Marie Bonaparte was responsible for the non-medical section. Together with René Allendy he wrote *La Psychanalyse et les Névroses* (Psychoanalysis and the neuroses), published by Payot in 1924. In 1931 he published *L'Échec de Baudelaire*, a psychoanalytic study of the poet's neurosis.

During the 1930s, Laforgue trained a number of students: Juliette Boutonier (Favez-Boutonier), Françoise Marett (Dolto) and her brother Philippe, Georges Mauco, the publisher Bernard Steele, the actor Alain Cuny, André Berge, and John Leuba, whom he supervised. These students regularly got together at Laforgue's home in the Var, where they formed the "Club des piqués," as they referred to themselves. After the war he psychoanalyzed Jacques Donnars and Mémie Grégoire.

In 1938–1939 Laforgue separated from Paulette Erickson and married Délia Clauzel. He was mobilized in 1939 as a military doctor in the French army.

In November 1940 he asked to become a member of the Berlin Institute and announced that he intended to found, in Paris, a French section of the Psychotherapy Society run by Professor Matthias Göring, with whom he corresponded until 1943. His request, which was repeated in 1941, did not materialize. His earlier membership in the International League against Anti-Semitism hardly inspired confidence among the Nazis. In 1941 he published *Psychopathologie de l'échec* (Psychopathology of failure), written around 1937, but without the chapter on Hitler. He destroyed the book during the Occupation and only one copy was given to Jean Rostand and is presumed lost. In 1942, at his home in the Midi, he provided protection for Jews and escapees from the German work camps. In 1944 he obtained authorization to publish a new edition of *Psychopathologie de l'échec*, for which he was reproached after the Liberation.

In 1945, following accusations by John Leuba, Laforgue was tried for collaboration. The case was dismissed for lack of evidence (the attempt to work with Göring was unknown at the time), but the separation between Laforgue and his colleagues at the Société psychanalytique de Paris continued to worsen.

In 1946 *Psyché*, created by Maryse Choisy, was the first psychoanalytic review to reappear after the war.

Laforgue contributed several articles and participated extensively in the preparation of the *Dictionnaire de psychanalyse et de psychotechnique*, published as a supplement to the review. His position against scientism and his spiritualist interests are confirmed here. But the idea of a form of psychopolitics based on applied psychoanalysis found little interest among his former colleagues and students. At the 1950 International Congress of Psychiatry, he claimed that in sixty percent of cases a rational technique would result in the elimination of nearly two thirds of the sessions then customary in analysis. After the 1953 split of Société psychanalytique de Paris and his resignation, Laforgue joined the Société française de psychanalyse (French Psychoanalytic Society).

He went into "exile" in Morocco, where he had traveled regularly since 1948, from December 1956 to 1959. There he founded the Institut de psychanalyse de Casablanca (Casablanca Institute for Psychoanalysis). Jean Bergeret, Jean Callier, and Monique Foissin, future members of the Société psychanalytique de Paris, began their training at the Institute.

At the end of his life, Laforgue was close to Father Bruno and his *Études carmélitaines*, and reproached psychoanalysts for the sectarianism, akin to religious fanaticism, that divided the various professional societies. The specialist of the neurosis of failure was soon forgotten by the members of the society he created when he died, March 6, 1962, following surgery.

JEAN-PIERRE BOURGERON

*Works discussed:* *Psychanalyse et les Névroses*, La; *Psychopathologie de l'échec*.

*Notions developed:* Failure neurosis; Scotomization.

*See also:* Allendy René Félix Eugène; Berge, André; Bonaparte, Marie Léon; Choisy, Maryse; Claude, Henri Charles Jules; Congrès des psychanalystes de langue française des pays romans; Dolto-Marett, Françoise; Embirikos, Andreas; *Évolution psychiatrique*, L; Favez-Boutonier, Juliette; France; Freud, Oliver; Hesnard, Angélo Louis Marie; International Federation of Psychoanalytic Societies; Leuba, John; Mauco, Georges; North African countries; *Psyché, revue internationale de psychanalyse et des sciences de l'homme* (Psyche, an international review of psychoanalysis and human sciences); Sainte-Anne Hospital; Schlumberger, Marc; Second World War: The effect on the development of psychoanalysis; Société psychanalytique de Paris and Institut de psychanalyse de Paris; Sokolnicka-Kutner, Eugénie.

### Bibliography

- Freud, Sigmund, and Laforgue, René. (1977). Correspondance Freud-Laforgue, préface d'André Bourguignon. *Nouvelle Revue de psychanalyse*, 15, 235–314.
- Laforgue, René. (1931). *L'Échec de Baudelaire*. Paris: Denoël & Steele; Geneva: Le Mont-Blanc.
- . (1941). *Psychopathologie de l'échec*. Marseille: Les Cahiers du Sud.
- Laforgue, René, and Allendy, René. (1924). *La Psychanalyse et les Névroses* (2nd ed.). Paris: Payot, 1950.
- Lilamand, Martine. (1980). René Laforgue, fondateur du mouvement psychanalytique français, sa vie, son œuvre. Certificat d'études spéciales de psychiatrie. Créteil: Université de Paris.

### Further Reading

- Mijolla Alain de. (1988a). "Psychoanalysis and psychoanalysts in France between 1939 and 1945", *Int Forum Psychoanalysis*, 12, 136–156, 2003, Stockholm.

---

## LAGACHE, DANIEL (1903–1972)

French physician, psychoanalyst, and professor at the Sorbonne, Daniel Lagache was born on December 3, 1903, in Paris, where he died on December 3, 1972.

An officer in the Legion of Honor, Lagache was recipient of an honorary doctorate from the University of Montreal and was a laureate of the Institut de France and Faculty of Medicine, Paris.

At age twelve, Lagache was strongly affected by the death of his father, a lawyer with the appeals court in Paris. Although deeply loved by his father, he felt that his mother preferred his youngest brother and consequently recalled his childhood as "bittersweet." With excellent grades at the Lycée Condorcet, he entered the École Normale Supérieure in 1924. Fascinating case presentations by famous psychologist Georges Dumas at Sainte-Anne's hospital motivated Lagache to pursue psychoanalysis. With fellow students Raymond Aron, Paul Nizan, and Jean-Paul Sartre, Lagache began a course in medicine, and became the only one among them to actually complete studies in medicine and philosophy. After passing his *agrégation* in philosophy in 1928, Lagache received his medical degree in 1934, worked in psychiatric hospitals for several years, and in 1937 served as chief physician in the clinic directed by Henri Claude, the eminent psychiatrist and neurologist. He was appointed professor of psychology at the

University of Strasbourg, succeeding Charles Blondel, in 1937.

From 1933 to 1936, Lagache underwent a training analysis with Rudolph Loewenstein, one of the founders of Paris Psychoanalytic Society (SPP). Lagache's perfect understanding of German allowed him to study Freud's works in the original as well as to read the German phenomenologists and psychopathologists. In 1937 his communication, "Deuil, mélancolie, manie" (Mourning, melancholia and mania) brought him full membership in the SPP. In 1938, at the Fifteenth International Psychoanalytic Congress in Paris, he offered his "Contribution à l'étude des idées d'infidélité homosexuelle dans la jalousie" (Contribution to the study of the ideas of homosexual infidelity in jealousy). During the war, expertise in forensic medicine and psychiatry led him to work in criminology. He made use of observations in cases of homicidal jealousy, and data he gathered on pathological jealousy would constitute the core of the two theses of his doctorate.

During the war, Lagache was initially an officer in the department of military health before being imprisoned; he subsequently escaped to become active in the Resistance and to rejoin the faculty of the University of Strasbourg, which had been relocated to Clermont-Ferrand, near Vichy. Receiving his doctorate in letters at the University of Paris in 1946, he obtained the chair of psychology at the Sorbonne in 1947, and in 1955, the chair of psychopathology. From 1946 to 1966 he also served as a member of the CNRS consultative assembly. In 1947 he founded and directed the collection "Bibliothèque de psychanalyse et de psychologie clinique" (Library of Psychoanalysis and Clinical Psychology, later called simply "Bibliothèque de la psychanalyse"), published by the Presses Universitaires de France. Lagache also was influential in the 1967 publication of *The Language of Psycho-Analysis* by Jean Laplanche and Jean-Bertrand Pontalis, a landmark in the history of psychoanalysis in France.

With Jacques Lacan, in 1953 Lagache founded the Société française de psychanalyse (SFP), which over the next eight years published the remarkable journal *La Psychanalyse*. After this group dissolved, in 1964 Lagache became co-founder and first president of the Association psychanalytique de France (APF), which was recognized in 1965 by the International Psychoanalytical Association (IPA). In 1968, a serious heart condition forced him to retire from official functions and to cut back his psychoanalytic practice.

Lagache's work from 1932 to 1968 includes, in addition to many books, over 170 articles and manuscripts, which were edited and published in six volumes by Eva Rosenblum. His masterpiece was *La jalousie amoureuse* (Jealousy; 1947); *Le travail du deuil* (The work of mourning; 1938) and *Le deuil pathologique* (Pathological mourning; 1956), include Freud and became outstanding titles of reference. His last manuscript, incomplete at his death, was *La folle du logis: La psychanalyse comme science exacte* (The madwoman in the attic: Psychoanalysis as an exact science; 1964). Lagache's language is limpid, concise, and simple.

Lagache's scientific authority, together with his dynamism and powers to convince, enabled him to pioneer the introduction of psychoanalysis into the French university system in 1937. His humanist orientation, scientific honesty, and unimpeachable integrity overcame the resistance of an academic world paralyzed by the fear of an upheaval in education due to Freudian ideas. As an accurate theorist of Freudian concepts, Lagache also played an influential role in promoting psychoanalysis among the general public. His contribution to the "Que sais-je?" series of brief primers, *Psychoanalyse* (1955/1963), was translated into twelve languages and is considered a masterpiece. He understood how to underpin psychoanalytic thought with reference to clinical experience, in the twenty-first century and his lectures at the Sorbonne remain relevant today. He was responsible for publishing numerous foreign works in France and established an international network of colleagues and collaborators. Selections from his collected works have been translated into English (Lagache, 1993) and Spanish. Engaged both in the creation of psychoanalytic institutions and in the organization of international congresses, Lagache was an active participant in various internequine disputes in French psychoanalysis and, more generally, played a major role in the history of the psychoanalytic movement, both in France and abroad.

EVA ROSENBLUM

*Work discussed: Jalousie amoureuse, La*

*See also:* Association psychanalytique de France; Bouvet, Maurice Charles Marie Germain; Criminology and psychoanalysis; *Documents et Débats*; Ego ideal; Ego ideal/ideal Ego; Fantasy (reverie); France; Heroic self, the; *Language of Psychoanalysis, The*; Loewenstein, Rudolph M.; Passion; *Psychanalyse, La*; *Psyché, revue internationale de psychanalyse et des sciences de l'homme*; psychoanalytic splits; Repetition; Société française de psychanalyse;

Société psychanalytique de Paris et Institut de psychanalyse de Paris; Sublimation; Working-off mechanisms.

### Bibliography

- Lagache, Daniel. (1947). *La jalousie amoureuse: Psychologie descriptive et psychanalyse*. Paris: Presses Universitaires de France.
- . (1950). Homosexuality and jealousy. *International Journal of Psycho-Analysis*, 31 (1–2), 24–31.
- . (1963). *Psychoanalyse*. New York: Walker. (Original work published 1955)
- . (1977–1986). *Oeuvres* (6 vols.). Paris: Presses Universitaires de France.
- . (1993). *The Work of Daniel Lagache: Selected Papers 1938-1964*. London: Karnac Books.

### Further Reading

- Mijolla Alain de. (1988a). "Psychoanalysis and psychoanalysts in France between 1939 and 1945", *Int Forum Psychoanalysis*, 12, 136–156, 2003, Stockholm.

## LAINÉ, TONY (1930–1992)

Tony Lainé, French psychiatrist and physician, was born in Paris on April 25, 1930, and died in Toronto on August 21, 1992. His father was an "anarcho-labor" militant worker, and his Jewish Siberian mother was an elementary school teacher and former student of Henri Wallon. He spent all his childhood in the Poitou region of France, where he was educated and studied medicine. He served as an intern in psychiatric hospitals in 1956, became a doctor of medicine in 1959, and passed the highly competitive entrance examination for hospital psychiatrists in 1960.

Influenced by the Second World War, violence, anti-Semitism, and social injustice, Lainé was first attracted to literature before taking a simultaneous interest in medicine and philosophy. He showed a sincere attachment to workers and the communist movement until the 1970s, a time of reckoning. He nevertheless remained attached to the struggle against all forms of exclusion. Out of sympathy with the Italian antipsychiatry movement, he invented particularly innovative institutional models of mental disorders.

After a personal analysis at the end of the 1970s, psychoanalysis was a constant inspiration for him. Lainé used psychoanalysis as a constant reference in his clinical practice, his theoretical reflections, and his

way of understanding institutions. He was greatly influenced by the thinking of Donald Winnicott, but he also related to theory in ways based essentially on his encounters with children and adolescents. Lainé used his talents as a storyteller to transmit the lessons he drew from his practice and make them accessible to all. He accorded great importance to the ethics of psychoanalysis: He insisted on leaving great scope for subjective evaluation, as opposed to more operational modes of practice.

Lainé took an interest in social structures and the unconscious and their reciprocal interactions. For more than thirty years he directed hospital units devoted to child and adolescent psychiatry and played a particularly active role treating child autism and psychosis, as well as adolescent problems. His contacts with film directors led him to make several television films: *La raison du plus fou* (The crazy one's reason), *La mal-vie* (Life pains), and *Le bébé est une personne* (The baby is a person). He also penned some notable popular publications: *La mort du père* (The death of Father), *Le petit donneur d'offrandes* (Little offerings), *Les violences de l'amour* (The violence of love). These films and publications contributed to making him well known.

PATRICE HUERRE

See also: Adolescent crisis; France; Infantile psychosis.

### Bibliography

Lainé, Tony. (1991). Droit et accession au statut d'adulte. *Nervure*, 4 (5), 26–30.

———. (1994, Sept.–Oct.). Conditions institutionnelles de la restauration des images parentales. *Courrier de Suresnes* (Centre national d'études et de formation pour l'enfance inadaptée), 61.

Lainé, Tony, and Lanouzière, Jacqueline. (1972). La relation d'objet chez l'enfant autiste. *Psychiatrie de l'enfant*, 15 (2), 287–398.

Lainé, Tony, Lanouzière, Jacqueline, and Delage, M. (1972). Conflit, répétition et pathologie du caractère. *Neuropsychiatrie de l'enfance et de l'adolescence*, 20 (5).

---

## LAING, RONALD DAVID (1927–1989)

Ronald David Laing, a British psychiatrist, was born in Glasgow, Scotland, on October 7, 1927. He died in St. Tropez, France, on August 23, 1989.

The only child of strictly Presbyterian Scottish parents of modest means, Laing studied classics at Hutchison's Boy's Grammar School and medicine at university. To his medical peer group in Glasgow, Laing showed himself to be an extraordinarily gifted musician, scholar, and discussant. He introduced them to Freud. In a population still heavily influenced by puritan values and respectable civic expectations, his behavioral example and the range of his mind were exhilarating. As a final year student Laing opted to become an assistant on psychiatric wards. This, together with his immediate postgraduate training for six months, led to his being graded a psychiatrist throughout two years compulsory military service. At Netley Hospital he spent hours sitting with very disturbed patients and thus found himself researching psychotic states.

Returning to Glasgow, he sought and was given facilities at Garthavel Royal Mental Hospital to set up a special nursing care unit for chronic schizophrenic women. The impressive results he obtained there were published in *The Lancet* (Cameron, McGhie and Laing, 1955). In Glasgow he continued the original clinical observations which would underpin his book, *The Divided Self*. Meanwhile he read very widely in philosophy and in phenomenological and existential psychiatry. Identified by J. D. Sutherland and John Bowlby as a candidate of outstanding originality and promise, Laing was offered a full-time salaried post at the Tavistock Clinic and a training analysis in conjunction with this at no cost to himself. His analyst was Charles Rycroft, his supervisors Marion Milner and Donald Winnicott. Although his qualification as an analyst was opposed by some teachers and administrators, it was strongly supported by those training analysts just mentioned.

The publication of *The Divided Self* in 1960 marked an important turning point in British psychiatry largely because Laing was able to collate, digest, synthesize, and crystallize ideas that were already current or latent in continental Europe and North America. It gave a voice to madness. Laing's originality lay in his power to complete the task and in his capacity to present the ideas, which had by then become his, with clinical illustrations, in such a way that a very large number of people were persuaded (and continue to be persuaded) that he was right.

*The Divided Self*, subtitled *An Existential Study in Sanity and Madness*, was Laing's first book and is widely regarded as his finest. Along with *The Politics of*

*Experience* (1967), it brought him worldwide fame. In time, Laing's importance in the United States waned, and he never completely recovered from the public versus private identity crisis of his late thirties.

JAMES R. HOOD

See also: *Anti-Oedipus: Capitalism and Schizophrenia*; Great Britain; Schizophrenia; Tavistock Clinic.

### **Bibliography**

- Laing, Ronald. (1960). *The divided self*. London: Tavistock Publications.
- . (1967). *The politics of experience*. London: Tavistock Publications.
- . (1985). *Wisdom, madness, and folly*. New York: McGraw-Hill.
- Laing, Ronald, and Esterson, Aaron. (1964). *Sanity, madness and the family*. London, Tavistock Publications.

## **LAMPL-DE GROOT, JEANNE (1895–1987)**

Jeanne Lampl-de Groot, psychoanalyst, psychiatrist, and psychologist, was born in Schiedam, on October 16, 1895, and died in Amsterdam on April 5, 1987, both in the Netherlands.

A psychoanalyst of the first generation, Lampl-de Groot grew up as the third of four children in a Jewish family, her father a businessman, her mother the daughter of a general practitioner. She studied medicine at Leiden and Amsterdam Universities and in 1921 became a doctor.

As a student, she came across Sigmund Freud's *The Interpretation of Dreams*, which fascinated her. After finishing her studies she wrote to Freud, asking him whether she could come to him to learn psychoanalysis. In April 1922 she began her work with Freud, at the age of twenty-seven, which was unusually young in those years. With Anna Freud among others, she attended courses and seminars of the Vienna Society and also worked in the psychiatric clinic of Wagner von Juaregg. She had planned to establish an analytic practice in Holland after her training but Freud recommended that she go to Berlin to work at the Berlin Institute for one or two years. So in 1925 she moved to Berlin, where she met her future husband Dr. Hans Lampl, originally from Vienna and a family friend of the Freuds. They had two daughters together.

When Hitler came into power the family moved back to Vienna, where the Psychoanalytic Society had been rejuvenated and analysis was flourishing. Moreover, Anna Freud had developed child analytic treatment and training. Lampl-de Groot was interested in child analysis, and on the recommendation of Dr. Siegfried Bernfeld, she had been a consultant psychiatric analyst in a child guidance clinic in Berlin. She was the recipient of one of the nine rings Freud presented to colleagues.

In 1938 the family emigrated to Holland because of the threat of the Hitler regime. They settled in Amsterdam, where they resumed their analytic practice and started a training scheme for analysts. At that time the Dutch Society, founded in 1917, only counted ten practicing members. During World War II this small group held courses and seminars "underground" and after the war founded the Dutch Psychoanalytic Institute (1946). The training procedure followed the model of those of Vienna and Berlin. In the same period Lampl-de Groot developed lively international contacts among psychoanalysts. In 1950 she organized the first post-war conference of European psychoanalysts in Amsterdam. She became a member of the board of the International Psychoanalytic Association (IPA) as vice-president. In 1953 she participated in an IPA commission, including Donald Winnicott, Phyllis Greenacre, and Ruth Eissler, to inform Jacques Lacan in Paris of criticisms of his educational and treatment methods. In 1963 she was appointed to be honorary vice-president of the IPA. In 1970 she was awarded an honorary doctorate in medicine by the University of Amsterdam, and honorary membership in the Deutsche Psychoanalytische Vereinigung. In 1971, she was made an honorary member of the Dutch Society of Psychiatry and Neurology, and was in 1977 nominated as honorary member of the Dutch Society of Psychoanalysis.

In her publications Lampl-de Groot covered a range of psychoanalytic topics. Narcissism and female psychology were two topics she addressed at length. Her writings have been of essential significance to the progress of psychoanalysis as a science. Her independent approach in supplementing Freud's work was apparent from her first article in 1927. She was the first author to describe and delineate the Oedipus complex in relation to growing girls, and she elaborated on this theme in later publications (1982). Strongly influenced by the ego psychology of Anna Freud and Heinz Hartmann, she used newly-gained

insights into the functioning of the ego and the role of omnipotence in narcissism in her work. There is an obvious link between her work on narcissism and Freud's. She integrated these ideas in her articles describing defence as a function of the ego and its importance for character development. She expressed her thoughts in beautifully simple and lucid prose, keeping away from theoretical phrases and always emphasizing the enormous complexity of the psyche while never neglecting the powerful force of the drives.

Her works were collected by friends and colleagues and presented to her on the occasion of her ninetieth birthday.

ELISABETH VERHAGE-STINS

*See also:* Feminine sexuality; Lampl, Hans; Netherlands; Rádo, Sándor; Wiener psychoanalytische Vereinigung.

### **Bibliography**

Lampl-de Groot, Jeanne. (1985). *Man and mind: Collected papers of Jeanne Lampl-de Groot, M.D.* New York: International Universities Press.

---

## **LAMPL, HANS (1889–1958)**

Hans Lampl, an Austrian physician, was born near Vienna on October 15, 1889, and died in Amsterdam on December 1, 1958.

Hans Lampl came from a family of Jewish civil servants. As the classmate, friend, and later the travel companion for Freud's oldest son Martin, he was a regular guest of the family. He studied medicine in Vienna and qualified as a physician in 1914. He was particularly interested in pathology and anatomy, and Freud advised him to specialize in these domains.

In 1920 he was invited to attend the sixth International Congress at The Hague and a year later went to Berlin to begin his analysis with Hanns Sachs, with whom he completed his training analysis. In 1922 he worked as a physician in the Berlin psychoanalytic polyclinic and in early 1926 he became an associate member and later a full member of the German Psychoanalytic Society.

It was in Berlin that he met his future wife, the Dutch physician Jeanne de Groot, who had been analyzed by Sigmund Freud and was working in the polyclinic. After Hitler took power in 1933, they left together for Vienna

and were accepted as members of the Vienna Psychoanalytic Society. In 1934 Lampl became president of the society and in 1935 he was elected treasurer of the Ambulatorium, an outpatient clinic.

In Vienna he collaborated with Sergei Feitelberg on task resolution in experimental physiology with a view to a research project to measure the libido, conducted by Bernfeld and Feitelberg. He also worked at the University of Vienna pharmacology institute until forbidden to do so after the Anschluss.

In 1938 he emigrated with his family to the Netherlands. In Amsterdam he became a member of the Netherlands Psychoanalytic Society and worked there as a training analyst. During World War II and after the disintegration of the society, he continued to train candidates privately. After the war he devoted himself essentially to the foundation of the new Netherlands training institute, becoming president in 1946.

He was killed in a traffic accident on his way to work on December 1, 1958.

ELKE MÜHLEITNER

*See also:* Lampl-deGroot, Jeanne; Netherlands.

### **Bibliography**

Lampl, Hans (1940). Einige Analogien in der Verhaltensweise von Vögeln und psychischen Mechanismen beim Menschen, *Internationale Zeitschrift für Psychoanalyse*, 25, 399–408.

Lampl, Hans, and Feitelberg, S. (1935). Methode zur Messung der Wärmetönung an der Grosshirnrinde. Wärmetönung der Grosshirnrinde bei Erregung und Ruhe bzw. Funktionshemmung, *Archiv für experimentelle Pathologie und Pharmakologie*, 177, 600–613, 726–736.

Mühlleitner, Elke (1992). *Biographisches Lexikon der Psychoanalyse (Die Mitglieder der Psychologischen Mittwoch-Gesellschaft und der Wiener Psychoanalytischen Vereinigung 1902–1938)*. Tübingen: Diskord.

---

## **LANDAUER, KARL (1887–1945)**

German psychoanalyst and physician Karl Landauer was born on October 12, 1887, in Munich and died on January 27, 1945, in the Nazi concentration camp of Bergen-Belsen.

From an Orthodox Jewish family, Landauer was the youngest of three children and the only son; his father, a

banker, died after a long illness when Karl was fourteen. When he began his medical studies, he intended to become a pediatrician, but subsequently decided on psychiatry.

To complement neuropsychiatric training with Julius Wagner-Jauregg, in 1912 Landauer took the advice of psychiatrist Max Isserlin, at the Kraepelin Institute in Munich, and began a training analysis with Freud. He joined the Vienna Psychoanalytic Society in the fall of 1913. With the outbreak of war the next year, he entered the military and served as a physician on both the Eastern and Western Front. His wartime experience with poison gas made him a pacifist.

From 1919, for reasons connected with his family, Landauer continued his psychiatric training in Frankfurt. In 1923, he opened a practice, principally devoted to psychoanalysis. He thereafter worked to establish another analytic community, similar to the one developing in Berlin. He organized local and international congresses (Würzburg, 1924; Bad Homburg, 1925; Wiesbaden, 1932) and he visited Freud every year. In 1926, he founded the Southwest German Psychoanalytic Group.

In 1929, together with Heinrich Meng, Frieda Fromm-Riechmann and Erich Fromm, Landauer established the Frankfurt Psychoanalytic Institute, at the invitation of Max Horkheimer, who was one of his analysts and the founder, six years earlier, of the Frankfurt Institute of Social Research. Landauer was also mentor to psychoanalyst Sigmund Heinrich Fuchs (Foulkes).

In 1933, with the rise of National Socialism, Landauer emigrated to Amsterdam, and for the rest of the decade he was the most important analyst in the Netherlands. In 1936, in celebration of Freud's eightieth birthday, he lectured before the Vienna Psychoanalytic Society and the Netherlands Psychoanalytic Society.

Failing to take any opportunity to leave the Netherlands for the United States with the approach of World War II, with the Nazi occupation Landauer experienced the gradual loss of personal and professional freedom. In 1943, he was arrested with his wife and his oldest daughter, and transferred from the concentration camp at Westerbork, near Amsterdam, to Bergen-Belsen. There he managed to practice analysis and provide counseling to patients before dying of malnutrition.

Landauer published some nineteen articles in psychoanalysis between 1914 and 1939. Among them are: "Spontanheilung einer Katatonie" (A spontaneous cure of catatonia; 1914); "'Passive' Technik" (The "passive" technique; 1924); "Äquivalente der Trauer" (Equivalents of mourning; 1925); "Zur psychosexuellen Genese der Dummheit" (Contribution to the psychosexual genesis of mental retardation; 1929); "Die Ich-Organisation in der Pubertät" (Ego organization in puberty; 1935); and "Die Affekte und ihre Entwicklung" (Affects and their development; 1936). A posthumous collection, *Theorie der Affekte und andere Schriften zur Ich-Organisation* (Theory of affects and other writings on the organization of the ego), appeared in 1991.

Landauer also presented the first case study of narcissistic identification with the lost object, as well as original technical considerations for the treatment of narcissistic disorders—an early attempt to combine Freud's structural model with his first theory of affects—and a study on the significance of motricity. A pioneer in analytic psychotherapy for children and teenagers, Landauer's description of the psychodynamics of thought inhibition influenced the Frankfurt School's pioneering research on the character of prejudice.

HANS-JOACHIM ROTHE

See also: Germany; Netherlands; Second World War: The effect on the development of psychoanalysis; Sigmund Freud Institute.

### Bibliography

- Bergmann, Martin S., and Hartman, Frank. (1976). *The Evolution of Psychoanalytic Technique*. New York: Basic Books.
- Laier, Michael. (1994). *Das Frankfurter Psychoanalytische Institut (1929-1933). Anfänge der Psychoanalyse in Frankfurt am Main*, Münster: LIT.
- Landauer, Karl. (1938). Affects, passions, and temperament. *International Journal of Psycho-Analysis*, 19, 388–415.
- . (1939). Some remarks on the formation of the anal-erotic character. *International Journal of Psycho-Analysis*, 20, 418–425.
- . (1991). *Theorie der Affekte und andere Schriften zur Ich-Organisation*. Frankfurt, Fischer.
- Plänkers, Tomas, Laier, Michael, Otto, Hans-Heinrich, et al. (1996). *Psychoanalysis in Frankfurt am Main.: Zerstörte Anfänge, Wiederannäherung, Entwicklungen*. Tübingen, Diskord.

Rothe, Hans-Joachim. (1987). *Zur Erinnerung an Karl Landauer. Geb. am 12.10.1887 in München, gest. am 27.1.1945 in Bergen-Belsen*. Frankfurt: Sigmund-Freud-Institut.

## LANGER, MARIE GLASS HAUSER DE (1910–1987)

Marie Glass Hauser de Langer, a physician and psychoanalyst, was born in Vienna in 1910 and died in Buenos Aires, Argentina, on December 27, 1987.

In her youth she joined the Austrian communist party in an attempt to compensate for the dual handicaps of being Jewish and a woman. She finished her medical studies in 1935 just as Austrian fascism was getting ready to ban Jews from working in hospital services. In 1934 the Vienna Psychoanalytic Society forbade its members to belong to the Institute or to be active in clandestine parties (the communist party had been dissolved in 1933). This information was communicated to Langer by her analyst, Richard Sterba, who terminated her analysis shortly thereafter. In 1936 she decided to emigrate to Spain in order to continue her political activity. Later she left for Uruguay.

After living in Montevideo, she settled in Argentina in 1942 and Langer occupied several important posts in the Argentine Psychoanalytic Association (APA): director of seminars and publications, treasurer, secretary, member of the training Commission, president and director of the Enrique-Racker psychoanalytic clinic. She taught at the Institute and worked as a training analyst for twenty-nine years. In 1970 she left the APA in order to denounce authoritarian tendencies inside psychoanalytic institutions. She was also a founding member of the Argentinean Association for Group Psychotherapy, as well as the Buenos Aires Society of Psychosomatic Medicine. Political persecution then forced her to emigrate to Mexico in 1974.

Langer's writings indicate several lines of research, which are distinguished by her efforts to highlight the influence of the social and cultural context on the practice and theory of psychoanalysis. Among the issues she addressed were: female sexuality, sterility, eternal fantasies, rationales for war, group psychoanalysis, anti-Semitism, methodological problems related to how psychoanalysis is taught, and some technical problems raised by training analysis.

Her book *Maternidad y Sexo* (1951; *Motherhood and Sexuality*, 1992) became a reference text for those

interested in questions relating to femininity. In it she traces, as she also does in several articles (1944–45; 1945–46; 1947–48; 1951; 1953), the position of women in history. In *Fantasías Eternas* (Eternal fantasies; 1957) her leitmotif is “to recognize the power of unconscious fantasies and the creation of certain myths that reflect a traumatic social and political situation that can also become a political weapon.”

In *Ideología e Idealización* (Ideology and idealization; 1959) she rethinks psychoanalytic societies, from the point of view of the specificity of their discipline and the pressure that comes to bear on analysts in institutions at certain periods in history. Her study of a text written by a former Nazi, Dr. Roberto Ley (1947–48), shortly before he committed suicide led her to confront the question of anti-Semitism as a symptom of social conflicts and collective anxiety.

She suffered from headaches, which led her to discover certain perturbations linked to the practice of psychoanalysis. In *Dos sueños de analistas* (Two dreams of psychoanalysts; 1952) she reveals the weight of the doubling/splitting that can come to bear on psychoanalysts in the course of their practice. In a prospective article she imagined the analysis of the year 2000 (1968). Marie Langer devoted her research (1957; 1961; 1963; 1965; 1970) to psychoanalytic group psychotherapy. She was also an active figure in the scientific and political life of Nicaragua and Cuba, where her later work constituted a comprehensive review of her knowledge and experience.

Her line of approach, her quest for truth, and her interest in human beings, especially women, made her a psychoanalyst who was deeply engaged with the society of her time and capable of exploring all the aspects of the discontent of our civilization.

JANINE PUGET

*See also:* Argentina; Brazil; Federación psicoanalítica de América latina; Mexico.

### *Bibliography*

Langer, Marie. (1947). Antisemitismo, paranoia y el testamento del doctor Ley. *Revista de psicoanálisis de la Asociación psicoanalítica argentina*, 5 (1), 93.

———. (1957). *Fantasías eternas a la luz del psicoanálisis*. Buenos Aires: Nova. APA.



- . (1957). *Psicoterapia del grupo, su enfoque psicoanalítico*. Buenos Aires: Paidós.
- . (1959). Ideología e idealización. *Revista de psicoanálisis de la Asociación psicoanalítica argentina*, 16 (4), 417.
- . (1989). *Marie Langer, from Vienna to Managua: Journey of a psychoanalyst* (Margaret Hooks, Trans.). London: Free Association Books.
- . (1992). *Motherhood and sexuality* (Nancy Caro Hollander, Trans.). New York: Guilford. (Original work published 1951)

## LANGUAGE AND DISTURBANCES OF LANGUAGE

Language is arguably omnipresent in psychoanalysis, if for no other reason than that it is the essential tool of analytic treatment.

Apart from Freud's early work *On Aphasia* (1891b), four passages in his writings may conveniently serve as vantage points from which to consider his approach to language. These are the beginning of chapter 6 of *The Interpretation of Dreams* (1900a), chapter 5 and chapter 8 of *The Psychopathology of Everyday Life* (1901b), and the last paragraph of "The Unconscious" (1915e). These passages point up the critical importance of taking language into account in connection with interpretation and with the way words are invested with meaning.

Chapter 6 of *The Interpretation of Dreams* begins with a brief introduction where Freud asks how the relationship between the manifest content of the dream and its latent content, which he also refers to as dream-thoughts, can best be represented. He envisions four possible models, the first three of which he rejects and the last of which he emphatically accepts. This relationship may thus be assimilated to that between two descriptions of the same facts in two different languages, or in terms of the translation of a text and its original, or again as analogous to the deciphering of hieroglyphics. None of these parallels satisfies Freud, although he does not clearly state why, and he eventually decides that the relationship is identical to that of the symbols of a rebus to its deeper meaning. The word "rebus," it is worth recalling, is a short form of the expression "*scribere in rebus*," that is, "to write with [representations of] things," in contrast to "*scribere in litteris*," "to write with letters."

The rebus, however, is not a pictogram or a story in pictures, but a succession of small figures with a

meaning that can be deciphered, each figure functioning either semantically or phonetically, so that a picture of a cat, for example, can denote either the word *cat* (assuming the pertinent language is English) or the sounds of the consonants and vowel that constitute that word. There are two points to remember here: a rebus assumes a given language, and we never know whether the figure functions as meaning or as sound. So, if the rebus is the prototype of the interpretable, the interpretable presupposes a specific language and the possibility that an element can have either a phonetic or a semantic value. Interpretation, for Freud, is therefore tied in its essence to language.

The study of slips of the tongue also involves a linguistic phenomenon, but one of an entirely different nature: a word that, within the spoken sequence of words, is substituted for another that it resembles phonetically but not semantically; sometimes it may even have the opposite meaning. For example, "*Geiz*," meaning "greed," replacing "*Geist*," "cleverness" or "wit." "*Sie haben alle Geiz*" (They are all greedy) is said instead of "*Sie haben alle Geist*" (They are all witty). The speaker may correct the first sentence with the second but it is the first that truly expresses her thought (*Psychopathology of Everyday Life*, 1901b, p. 64). The slip is facilitated when a close phonetic likeness is combined with a great semantic distance, allowing a censored opinion to reveal itself in part. Sometimes a neologism is needed.

Later in the *Psychopathology*, Freud uses a parapraxis of his own to illustrate the importance of language in the interpretation of bungled actions. He relates how one evening he went to the suburbs of Vienna to examine a patient who was suffering from the inability to use her legs in order to settle a differential diagnosis as between hysteria (curable) and myelitis (incurable). He did not enjoy this type of work, because some time earlier he had made a mistake in a similar case and rebuked himself for being an ass—or, in Hebrew, *chamer*. However, when he got to his staircase landing, he realized that he had put his reflex hammer in his pocket instead of his tuning fork. He then remembered that he had recently examined an imbecile child—"an ass"—who had grabbed this tuning fork and refused to let it go. The basis of his interpretation was the phonetic proximity between the German *hammer* and *chamer*. (pp. 165–66).

The interpretation of a parapraxis therefore assumes, once again, the use of language—and not language in general, but a specific language.

In his metapsychological paper on “The Unconscious” (1915e), Freud describes quite another role played by language. He notes that while, in the most advanced forms of schizophrenia, the subject no longer cathects anything but himself, adopting a fully narcissistic posture, during the early stages he can still cathect word-presentations and so avoid thoroughgoing autism.

The above distinctions between four aspects of the metapsychological relationship to language may be slightly artificial, but they all serve to underscore the fact that language always displays both a phonetic and a semantic aspect.

GEORGES LANTÉRI-LAURA

*See also:* Action-language; Aphasia; Brain and psychoanalysis, the; “Claims of Psychoanalysis to Scientific Interest”; Colloque sur l’inconscient; “Confusion of Tongues between Adults and the Child”; Dementia; I; Ideational representation; *Infans*; Infantile psychosis; Innervation; Interpretation; Lacan, Jacques-Marie Émile; Letter, the; Linguistics and psychoanalysis; Literature and psychoanalysis; Metaphor; Metonymy; Multilingualism and psychoanalysis; Non-verbal communication; Organic psychosis; Preconscious; *Psychanalyse, La*; Thing-presentation; Signifier; Signifier/signified; Slips of the tongue; Subject’s desire; Symbolic, the (Lacan); Symptom/sinthome; Technique with adults, psychoanalytic; Want of being/lack of being; Word association.

### **Bibliography**

- Freud, Sigmund. (1891b). On aphasia: A critical study (E. Stengel, Trans.). New York: International Universities Press, 1953.
- . (1900a). The interpretation of dreams. *SE*, 4–5.
- . (1901b). The psychopathology of everyday life. *SE*, 6.
- . (1915e). The unconscious. *SE*, 14: 159–204.
- Lantéri-Laura, Georges. (1966) *Les Apports de la linguistique à la psychiatrie contemporaine*. Paris: Masson.
- . (1994). *Recherches psychiatriques 1. Sur le langage*. Paris: Sciences en situation.
- Martin, Jean-Luc. (1984) La question du langage chez Freud, de 1891 à 1901. *L'évolution psychiatrique*, 2, 451–486.

### **Further Reading**

- Amati-Mehler, Jacqueline, et al. (1993). *The babel of the unconscious. Mother tongue and foreign languages in the psychoanalytic dimension*. Madison, CT: International Universities Press.

Forrester, John. (1980). *Language and the origins of psychoanalysis*. New York: Columbia University Press.

Orange, Donna. (2003). Why language matters to psychoanalysis. *Psychoanalytic Dialogues*, 13, 77–104.

Rizzuto, Ana-Maria. (2002). Speech events, language development, and the clinical situation. *International Journal of Psychoanalysis*, 83, 1325–1344.

Shapiro, Theodore. (1988). Language structure and psychoanalysis. *Journal of the American Psychoanalytic Association*, 36(S), 339–358.

Spence, Donald P. (1982). Some clinical implications of action language. *Journal of the American Psychoanalytic Association*, 30, 169–184.

## **LANGUAGE OF PSYCHOANALYSIS, THE**

*Vocabulaire de la psychanalyse (The Language of Psycho-Analysis)* is neither a dictionary nor an encyclopedia, but an inventory of the major concepts of psychoanalysis. Cursory readers might confine themselves to the brief definitions that precede the historical discussions of concepts. However, the most important work presented in this book is its analysis of the tools of psychoanalytic thinking: a methodical and thoroughgoing investigation ever ready to track down contradictions. Basing this book almost exclusively on the work of Freud, Laplanche and Pontalis set out to bring the concepts of psychoanalysis to life, showing their complexity and tracing their development through Freud’s writings. By hewing close to Freud’s texts, often retranslated into French by the authors, the *Vocabulaire* makes it possible to put these concepts to work, as it were, while steering clear of dogmatism.

The fortunate encounters and circumstances that gave birth to the *Vocabulaire* are worth recalling. The two authors became friends as soon as they arrived in Paris in 1941 to take preparatory classes in the humanities at the Lycée Henri IV. They both were candidates for the advanced teacher-qualifying examinations (*concours d’agrégation*) in philosophy, and both were successful. Thereafter Pontalis proceeded into university teaching, while Laplanche turned to medicine. Ten years later, when Pontalis was a research assistant at the Centre national de la recherche scientifique (National Center for Scientific Research) and Laplanche was an assistant professor at the Sorbonne, both found themselves under the authority of Daniel Lagache, university professor and series editor at the Presses universitaires de France. At that time Lagache, at the request of

UNESCO, was organizing a large group of researchers to produce a dictionary of terms used in the human sciences. This project came to naught, but Lagache, aware of Laplanche and Pontalis's interest in psychoanalysis, proposed that they write what became the *Vocabulaire de la psychanalyse*.

The two worked on the book from 1960 to 1967. They met several times a week to review their reading on one or more concepts. After discussion, they wrote in such close collaboration that the thinking of the two men was inextricably linked. From time to time they would show their work to Lagache, who granted them complete authorial independence. The work was published under his editorship, and he contributed a preface giving the background and history of the project.

While the book was being written, Jacques Lacan was urging a “return to Freud.” Laplanche and Pontalis accepted this proposal and, instead of simply elaborating a set of concepts, treated their task as a full-scale research project. During this period the Association psychanalytique de France (French Psychoanalytic Association) came into being (1963). Lagache, Laplanche, and Pontalis all became members, marking their distance from Lacan.

The first edition of the *Vocabulaire* appeared in 1967. Thirteen more were to follow. The book was first translated into English, under the title *The Language of Psycho-Analysis*, thanks to the collaboration and friendship between Masud Khan and Pontalis. That English-language readers should thus obtain access to a French work of this kind was considered extraordinary at the time. Subsequently the book was translated into Spanish, Italian, Portuguese, Hungarian, Russian, Rumanian, Croat, German, Japanese, Polish, Greek, Arabic, Korean, Slovakian, Swedish, and Turkish—seventeen languages in all. In 1997, thirty years after its first appearance, the *Vocabulaire* was issued in a student's edition, which gave it a much wider circulation. It is undoubtedly the most frequently cited work in the entire French psychoanalytic literature.

The authors' choice of concepts for inclusion focused on those notions that help explain Freud's theory of the mental apparatus. Almost all of the three hundred terms dealt with were taken from Freud's work. The exceptions included a few Kleinian notions (good/bad object, depressive position, paranoid position), a few Lacanian concepts (foreclosure, the symbolic, mirror phase), a Jungian one (Electra complex),

an Adlerian one (inferiority complex), Spitz's hospitalism, and Winnicott's transitional object. A three-tier system of cross-references among entries and to the bibliography encouraged readers to view topics from a succession of different angles.

Some of Laplanche and Pontalis's lengthier entries, such as “Ego” and “Death instinct” set forth their own theoretical positions. As to theoretical orientation, apart from adhering as closely as possible to Freud's work itself, they rejected ego psychology, for example, and expressed reservations about the theoretical approaches of Jacques Lacan and Melanie Klein. The *Vocabulaire* initiated the development of a number of notions not thoroughly conceptualized by Freud, among them deferred action and anaclysis, which would later constitute important milestones in the thinking of Jean Laplanche.

JEAN-LOUIS BRENOT

See also: Association psychanalytique de France; France; Great Britain; Lagache, Daniel.

#### Source Citation

Laplanche, Jean, and Pontalis, Jean-Bertrand. (1974). *The language of psychoanalysis* (Donald Nicholson-Smith, Trans.). New York: Norton; (1967). *Vocabulaire de la psychanalyse*. Paris: Presses Universitaires de France.

---

## LANZER, ERNST (1878–1918)

Austrian lawyer Ernst Lanzer, a patient of Freud, was born in Vienna on January 22, 1878, and died in Russia in 1914.

Dr. Ernst Lanzer is more widely known by the pseudonyms the “Rat Man” and “Dr. Lorenz”, given him by Freud and James Strachey respectively. He is the subject of Freud's case history (1909d). His parents both came from Silesia: his mother Rosa (née Herlinger) was born in 1844 and his father in 1825. (Freud and the Rat Man were alike in that at their birth, they had fathers who were old enough to be grandfathers.)

The respective names, pseudonyms, and births of the Rat Man's siblings are as follows: Hedwig (Hilde), 1870; Camilla (Katherine), 1872; Rosalie (Constanze), 1874; Robert (Hans), 1879; Olga (Julie), 1880; and Gertrud (Gerda), 1886. The deaths of Camilla (1881), his father (1899), and his aunt (1901) had variously immediate and persistent perturbing influences on the Rat Man's personal and professional life.

In 1897 Lanzer enrolled in the Law Faculty of the University of Vienna, but he could not complete his doctorate until ten years later, shortly before his analysis with Freud. Beset with similar ambivalence and procrastination, he finally made a childless marriage with his cousin Gisela Adler in November, 1908, which was not only about one and a half years after their engagement but also some ten years after he first fell in love with her.

It was during military maneuvers from August 11 to September, 1907, that Lanzer first suffered from his peculiar obsession with rats. Military records from the same year indicate owing to his father's death that he inherited 50,000 kronen, an amount starkly contrasting with the cost (3.80 kronen) of the pince-nez that he lost on maneuvers and that precipitated him into an obsessional frenzy.

Lanzer entered into an analysis with Freud on October 1, 1907. With his conflicts over work being partially resolved (he had previously worked only a little over two months), Lanzer found employment in 1908; yet he changed law offices four times before officially becoming an attorney (*Rechtsanwalt*) and finding more secure employment in 1913. In August, 1914 he was activated into military service; he was taken prisoner by the Russians on November 21, 1914 and died four days later.

PATRICK MAHONY

See also: "Notes upon a Case of Obsessional Neurosis" (Rat Man).

### **Bibliography**

Freud, Sigmund. (1909b). Analysis of a phobia in a five-year-old boy. *SE*, 10: 1–149.

———. (1909d). Notes upon a case of obsessional neurosis. *SE*, 10: 151–318.

Mahony, Patrick J. (1992). *Freud and the Rat Man*. New Haven, CT: Yale University Press.

Nunberg, Hermann, and Federn, Ernst (1962–1975). *Minutes of the Vienna Psychoanalytic Society*. New York: International Universities Press.

---

## **LATENCY PERIOD**

The *latency period* is the stage of suspension of psychosexual development between the age of five and six

and puberty. During this period, sexual activity and interest tends to decrease, a consequence of repression, secondary identifications and the establishing of the superego, resulting in the resolution or the waning (*Untergang*) of the Oedipus complex. As the drives slow their pace, inhibitions surface, the product of the building of moral and aesthetic dams (shame, disgust, and modesty) through reaction formations (counter-cathexes). By the same token, with sublimation, there is a change of goal in drive discharge toward socially acceptable and valorized activities, together with the formation of an ideal, while in object relations feelings of tenderness (aim-inhibition) take precedence over oedipal eroticization.

Freud articulated this concept (1905d) based on his clinical observations, emphasizing its significance for the later normalcy of the individual subject and his insertion into the culture. The latency period is also important for the progress of civilization.

Beyond the descriptive point of view and the psychic mechanisms at work within it, the notion of a latency period seems like a logical necessity for posing certain questions. Through it infantile sexuality is approached from the perspective of future neurosis or normalcy, highlighting what Freud later called "the two-phase start" of human sexual development. In earlier writings he had already stressed the importance of sexuality in the etiology of neuroses. He had to mark the connection of neuroses with infantile experiences, the notion of deferred action and discontinuities in the evolution of sexuality. He also developed the notion of infantile amnesia through what he termed "screen memories."

Freud claimed to have borrowed the term "latency period" from Wilhelm Fliess, although nothing of the sort can be found in their known correspondence. It seems that the term *Latenzzeit* first surfaced in Fliess's work in 1909, but it meant something else in that context; also, its definition was not consistent conceptually with Krafft-Ebing's use years earlier ("*sexuelle Latenzperiode*").

Although latency appeared to be a keystone concept in his theoretical edifice, Freud did not make much of an effort to develop it. Nevertheless, in his later writings, he alluded to it frequently, although without adding anything substantial to its explanation.

However, he did make two elucidations about the latency period: In 1924 Freud affirmed that he had "no

doubt that the chronological and causal relations described here between the Oedipus complex, sexual intimidation (the threat of castration), the formation of the super-ego and the beginning of the latency period are of a typical kind" (1924d, p. 179); and in 1926 he emphasized that the struggle against the temptation of onanism is a major task, a combat ordinarily productive of symptoms like rituals or ceremonies. Subsequently he singled out the emergence of anxiety in response to the imperatives of the superego as characteristic of the latency period.

Other concepts in Freud's works can be useful in understanding latency, although he did not specifically link them to it: primary and secondary thought, the pleasure principle and the reality principle, the preconscious, fantasy, literary creation and games, daydreams and the family romance, the notions of psychic work and working through.

Throughout his work, in order to explicate this period, Freud oscillated between phylogenetic and biological formulations and formulations conditioned by the ontogenetic model and education, causal agents that he sometimes superimposed upon one another, as in the note he added in 1935 to *An Autobiographical Study*: "The period of latency is a physiological phenomenon. It can, however, only give rise to a complete interruption of sexual life in cultural organizations which have made the suppression of infantile sexuality a part of their system" (1925d [1924], p. 37).

Defined as an anodyne stage between two major periods of sexuality, the latency period has not been studied very much. Rodolfo Urribarri reformulated certain notions, insisting less on the temporal aspect than on the basis of the construction of the superego, which obliges the ego to cover itself by means of symbolization and displacement in order to allow drive discharge through the operation of various mechanisms under the control of sublimation, while utilizing diverse external resources, a process he terms the "work of latency." Urribarri also stressed modifications that occur in thought and language, the preponderant role and the functionality of the preconscious and of formations proper to it, like daydreams and the family romance. He also was able to identify sex differences in the representations of the body in games and drawing, which can be explained as a way of distinguishing functionality and genital differences. This in a way is typical of the work of latency, which precedes and conditions the masculine-feminine differentiation.

In this organization of latency, the psychic apparatus evolves while becoming more complicated by affording an outlet to the drives and expanding the subject's resources and the range of his social participation, and also extending psychosexual evolution in a disguised and subtle manner.

RODOLFO URRIBARRI

*See also:* Bornstein, Berta; Genital stage; Infantile amnesia; Libidinal development; *Moses and Monotheism*; Oedipus complex; *Psychology of Women. A Psychoanalytic Interpretation, The*; Psychosexual development; Puberty; Stage (or phase); *Three Essays on the Theory of Sexuality*.

### Bibliography

- Freud, Sigmund. (1905d). Three essays on the theory of sexuality. *SE*, 7: 123–243.
- . (1924d). The dissolution of the Oedipus complex. *SE*, 19: 171–179.
- . (1925d [1924]). An autobiographical study. *SE*, 20: 1–74.
- . (1926d [1925]). Inhibitions, symptoms and anxiety. *SE*, 20: 75–172.
- Urribarri, Rodolfo. (1999). Descorriendo el velo. Sobre el trabajo de la latencia. *Revista de Psicoanálisis de la Asociación Psicoanalítica Argentina*, 66, 1.

### Further Reading

- Becker, Ted. (1974). On latency. *Psychoanalytic Study of the Child*, 29, 3–12.
- Bornstein, Berta. (1951). On latency. *Psychoanalytic Study of the Child*, 6, 279–285.
- Clower, Virginia L. (1976). Theoretical implications of masturbation in latency girls. *Journal of the American Psychoanalytic Association*, 24, 109–126.
- Clowes, Erika. (1996). Oedipal themes in latency: Analysis of the "farmer's daughter" joke. *Psychoanalytic Study of the Child*, 51, 436–454.
- Sarnoff, Charles. (1976). *Latency*. New York: Jason Aronson.

## LATENT

Latent dream thoughts (latent content) are the meanings psychoanalytic interpretation discovers in the manifest dream (the narrative the dreamer constructs of his dream).

Freud introduced the contrast between manifest and latent in *The Interpretation of Dreams* (1900a), and he never abandoned this distinction, as witness *An Outline of Psychoanalysis* (1940a [1938]).

Latent thoughts (also called by Freud “dream thoughts” or “latent content”) are primary; they are the motor of the dream. They are comprised of infantile memories—of “egoistic,” sexual, or incestuous contents—which because of their moral unacceptability are rejected by the censorship. They are marked by the primary processes (condensation, displacement, figurability) and undergo the “distortions” that constitute the “dream work.”

Unconscious latent thoughts—the demands of the drives and their prohibition—are the foundation of the dream and exert an attractive power over certain pre-conscious formations. Residues of the day, events of the day before, function as possible jumping-off places for associations allowing the dream to be interpreted.

Over time, accumulated clinical experience and theoretical developments nuanced Freud’s initial stark distinction between manifest and latent. In the *Introductory Lectures on Psycho-Analysis*, Freud conceded that “one manifest element can replace several latent ones or one latent element can be replaced by several manifest ones” (1916–17a [1915–17], p. 125), arguing that dream interpretation can be based either on pre-conscious content or on the unconscious. After Freud’s introduction of the second topography (1920–25), a notion even arose of “thought-transference” (1933a, p. 40) suggesting circulation of latent thought between two persons (and not only within a mental apparatus).

In 1933 and 1938 Freud returned to the notion of the latent content of the dream, emphasizing its unconscious character. In effect it was a “primitive language without any grammar,” in which “only the raw material of thought is expressed and abstract terms are taken back to the concrete ones that are at their basis” (1933a, p. 20), where temporal relations are transformed into spatial ones, and “contraries are not kept apart but treated as though they were identical” (1940a [1938], p.169). The latent is fashioned out of a “forgotten childhood,” and of an “archaic heritage, which a child brings with him into the world, before any experience of his own, influenced by the experiences of his ancestors” (p. 167). The content of dreams is said to be like that of tales and myths, and “to constitute a source of human prehistory.”

Freud reported noticing the latent functioning of psyches in treatments handled by colleagues: Helene Deutsch observed a “thought transference,” a phenomenon also recorded by Dorothy Burlingham between a mother and a son who were both undergoing psychotherapy.

In present-day theory, the “latent” may describe an unconscious psychic communication between the analyst and the analysand: the transference is intertwined with the counter-transference, the unconscious of the analyst as important to the outcome as that of the analysand, and the analyst’s interpretation may also have a “latent” aspect (Jean-Paul Valabrega). This approach takes as its starting point Freud’s remark that there is a “secret language” created “secret language” created “between two people who see a lot of each other” (1933a, p. 49).

Within the treatment, an analyst’s dream of the patient in session may represent the latent fantasy functioning of the two psyches, and perhaps the starting point of an essential working through (André Missenard). An analogous function can be served by a “chimera” (Michel de M’Uzan), or by “co-thinking” (Daniel Widlöcher). Outside the treatment, in certain group situations with analyst(s) (small groups, combined therapies, families in psychotherapy) a latent fantasy system is said to underlie a shared psychic functioning.

Manifest and latent were notions introduced by Freud in connection with theories of the dream and of the mental approaches. Like other concepts, they were the product of his self-analysis. Since 1900, the use and the meaning of the idea of the latent has greatly evolved, as witness the specific place and strict meaning accorded to it currently in the theory of psychic functioning during treatment, as well as its broader and more descriptive application in clinical thinking to latent homosexuality, latent depression, latent perversion, and so on.

ANDRÉ MISSEARD

*See also:* Clinging instinct; Condensation; Dream; *On Dreams*; Fantasy; *Five Lectures on Psycho-Analysis*; Homosexuality; Interpretation; Interpretation of dreams (analytical psychology); *Interpretation of Dreams, The*; Latent dream thoughts; Manifest; Primary process/secondary process; Representability; Thought; Wish fulfillment.

**Bibliography**

- Anzieu, Didier, et al. (1990). *Psychic envelopes* (Daphne Briggs, Trans.). London: Karnac Books.
- Missenard, André. (1987). L'enveloppe du rêve et le fantasme de psyché commune. In Anzieu, Didier, Houzel, Didier, et al., *Les enveloppes psychiques*. Paris: Dunod.
- M'Uzan, Michel de. (1994). *La bouche de L'Inconscient*. Paris: Gallimard.
- Valabrega, Jean-Paul. (1980). *Phantasme, mythe, corps et sens: Une théorie psychanalytique de la connaissance*. Paris: Payot.
- Widlöcher, Daniel (1970). *Les nouvelles cartes de la psychanalyse*. Paris: Odile Jacob.

**LATENT DREAM THOUGHTS**

The expression “latent dream thoughts” comes up frequently in the writings of Freud; while the term as a whole has a very definite meaning, the same cannot be said for “thoughts.”

“Latent” was opposed to “manifest” in the context of the “manifest content” of the dream and its “latent content.” Taking advantage of the weakening of the censorship during sleep, the dream fulfills wishes repressed during the waking state. This can only happen at the cost of transformations and distortions created by the dream work, which translates the latent content into manifest content (or dream narrative). The interpretation of the dream follows the same route in reverse, decoding the transformations effected by the dream work so as to bring out the latent on the basis of the manifest content. Freud illustrated this with great flair, for instance, in *The Interpretation of Dreams* (1900a), and in his case histories of Dora (1905e) and the “Wolf Man” (1918b).

This “latent content” is made up of what Freud calls “latent thoughts.” This expression, always used in the plural, was never precisely described. In fact, however, the context of its use made it quite clear that it connoted representations, affects, wishes, and conflictual patterns, all deeply marked by infantilism and fantasy. Latent thoughts also subsume whatever supplies the dream’s “raw material”: the day’s residues, somatic sensations, and excitations that directly impact instinctual impulses.

Such a use of the word *thoughts* might be questioned, thoughts usually being described as conscious. Yet Freud was very explicit in this respect: The term is

justified because it referred to psychic contents and processes, albeit preconscious or unconscious ones. Freud explained on a number of occasions after 1912 (e.g., 1912g, 1940a) that latent dream thoughts were generally preconscious; they are utilized by the dream-work because they serve as a relay point and medium for unconscious cathexes.

ROGER PERRON

See also: Dream; Sense/nonsense; Translation.

**Bibliography**

- Freud, Sigmund. (1900a). The interpretation of dreams. Part I, *SE*, 4: 1–338; Part II, *SE*, 5: 339–625.
- . (1912g). A note on the unconscious in psychoanalysis. *SE*, 12: 255–266.
- . (1940a). An outline of psycho-analysis. *SE*, 23: 139–207.

**LAURENT-LUCAS-CHAMPIONNIÈRE-MAUGÉ, ODETTE (1892–1964)**

Odette Laurent-Lucas-Championnière-Maugé, French physician and psychoanalyst, was born in Rosny-sous-Bois on October 18, 1892, and died in Prépatour-Vendôme in the Loir-et-Cher department of France on October 21, 1964.

She worked in the Bretonneau hospital with Françoise Murette (later Dolto). In their Paris apartment she and her husband, Henri Codet, often hosted meetings of a group for the study of the evolution of psychiatry. Marie Bonaparte analyzed her. She was appointed a contributing member of the Société psychanalytique de Paris (Paris analytic Society) on November 20, 1934, at the same time as Jacques Lacan and became a full member on June 18, 1935. During the 1930s she attended the meetings of the Soroptimist, the French branch of a U.S. union for women of all occupations. Following the death of her first husband in an automobile accident in 1939, she married the architect Laurent Lucas-Championnière.

Her article “À propos de trois cas d’anorexie mentale” (On three cases of anorexia nervosa), published in 1939 under the name of Odette Codet and republished in 1948, presents the cases of three girls between the ages of three and fifteen. In it she highlighted the fact that conflicts increase in complexity with the age

of the subject and stressed that parental attitudes have a primordial role in the genesis and treatment of such conflicts “to such a degree that we sometimes wonder . . . whether the real solution might not be to psychoanalyze the parents.”

In June 1953, during the conflict in the Paris Psychoanalytic Society against the “liberals” and Sacha Nacht’s group, Odette, backed by Marie Bonaparte, proposed the following motion: “Having remarked its profound disagreement with its president, Jacques Lacan, as noted in the session of June 2, the general assembly of the Paris Psychoanalytic Society organized in administrative session cannot testify to its faith in him and asks its vice-president to assume the role of president until the election of leaders in accordance with the statutes.” The adoption of this motion on June 16 signaled a split: Lacan resigned, and Daniel Lagache took over as president but later resigned from the Paris Psychoanalytic Society to create the French Psychoanalytic Society.

While president of the Paris Psychoanalytic Society in 1959, she began to suffer from arterial illness and had to retire. She became an honorary member in 1963.

JEAN-PIERRE BOURGERON

*See also:* France.

### **Bibliography**

Codet, Odette. (1939). À propos de trois cas d’anorexie mentale. *Revue française de psychanalyse*, 11 (2), 253–272. (Republished: (1948). *Revue française de psychanalyse*, 12 (1), 81–100.)

## **LAW AND PSYCHOANALYSIS**

While psychoanalysis focuses on the individual subject, law refers to the collection of guidelines for behavior directed at all members of society. There are challenges therefore in establishing a dialogue between two disciplines whose objectives and challenges are so far apart. Yet, the necessity of psychoanalysis engaging with the human leads to its involvement with the foundations of societal values. It cannot therefore avoid taking an interest in the law, which means it must ask the same questions differently. Moreover, the discovery of a Freud who expresses himself like a lawyer justifies a new interpretation of some of his writings.

Although Freud from time to time took an interest in aspects of the legal process (1906c, 1916d, 1931d), he never tried to explain the possible interactions between law and psychoanalysis. Nonetheless, the questions of guilt and crime—primarily through the oedipal murder of the father and incest—are presented in a way that is so fundamental to his work that the confrontation of the two disciplines becomes inevitable, crime—even though perpetrated by the unconscious—leading to trial.

It was when he abandoned a legal career to turn his attention to science that Freud, in a letter to his friend Emil Fluss on May 1, 1873 (1925d), used the word *Prozess* (trial) for the first time. Rather than getting involved in real trials [*Prozesse*], he will study the “millennial cases of nature” so he can bear witness to its “eternal trials.” The use of this legal term is not an isolated occurrence in the Freudian corpus. The frequency and occurrence of its use justify seeing it as a kind of fetish word, a wink at his youthful wish to become a lawyer. He went so far as to talk about a “psychic trial” (1905d). The focus, in the Freudian corpus, on the use of a specifically legal vocabulary (conflict [*Konflikt*], defense [*Abwehr*], conviction [*Verurteilung* or *Urteilsverwerfung*], punishment [*Stafbedürfnis*]) demonstrates that the intersection of the two disciplines was not accidental.

If the psychic apparatus needs to organize a system of defense and condemnation, it is because unconscious guilt engages the subject in a continuous trial. The operation of the psyche demonstrates concrete links with that of the legal process once the question of guilt is introduced. The appearance in Freud’s work of references to a legal vocabulary, as well as to functions that are part of legal works, can be seen clearly from an examination of the multiple roles attributed by the founder of psychoanalysis to the “agency” of the superego. We find that the image he presents is that of a court that will entirely assume the burden of all legal responsibilities. The Freudian superego assumes the responsibility of legislator, judge, supreme court, attorney (for the id), public prosecutor, and even grief counselor. It also sometimes serves as a vigilante. Freud shows himself to be a skilled proceduralist by identifying the putative fatherhood referred to by lawyers (*Pater incertus est . . .*) and, when he points out the “progress of civilization” that characterizes the “transition from mother to father” (1909d, 1939a [1934–1938]), he borrows the specific vocabulary of the law



of evidence. The legal context in his work is supported by the explicit reference to Aeschylus's *Oresteia*. It appears that the reference to legal institutions to understand and attempt to resolve interior conflict does not exhaust the vision of Freud as jurist shown by his work. But it is with reference to the murder of the father that the field of interaction between law and psychoanalysis is the most fecund.

Aside from the opportunities presented by the presence of a Freudian legal vocabulary, although frequently hidden by translations that systematically “delegalize” his language, the fact that the legal functions attributed by Freud to the mental apparatus are visibly inspired by those attributed to the participants in the Last Judgment enables us to hypothesize a possible scriptural origin to his legal conception of mental agencies—especially the superego—when he evokes the “judicial activity of the moral conscience” (1933a [1932]). Another facet of Freud's work is revealed by his knowledge of Pauline thought and, more generally, of the Bible, the book in which Sigmund was taught to read by his father.

MARIE-DOMINIQUE TRAPET

See also: Criminology and psychoanalysis.

### **Bibliography**

- Laplanche, Jean. (1992). *La révolution copernicienne inachevée*. Paris: Aubier.
- Mijolla-Mellor, Sophie de. (1993). Le “bon droit” du criminel. *Topique*, 52, 141–161.
- Trapet, Marie Aleth. (1998). *Les adages, souvenirs d'enfance du droit, esquisse d'une métapsychologie des adages*. Dissertation, University of Paris-VII.
- Trapet, Marie-Dominique. (1998). *Le droit dans l'œuvre de Freud*. Dissertation, University of Paris-VII.

---

## **LAW OF THE FATHER**

In 1897 Freud remarked, on the basis of his analysis of his first patients and his self-analysis, that “The father forbids the child from realizing its unconscious wish to sleep with his mother” (letter to Fliess, October 15, 1897). This first outline of the Oedipus complex, which now appears simplistic, grew increasingly complex throughout Freud's research. In time the Law of the Father turned out to be directed both toward the mother (“You will not reintegrate your product”) as

well as her offspring swept up by desire. The law is also accompanied by an injunction against cannibalism and murder, and hold up ideals, primarily sexual ones (“Later you will enjoy, like me, a woman from another family”). Once introjected, this becomes the origin of the superego and ego ideal. The repression of drives, their suppression and sublimation, are the principal outcomes of the conflict that connects them structurally to this law.

Freud quickly recognized that the actual presence of a father is not the best guarantee of the fulfillment of this law: An absent or dead father can serve as the agent, as well as or better than the living father. This led to the creation of the myth of the primitive father (a, 1912–1913a). Jacques Lacan showed that this Law of the Father, to the extent that it serves as a principle of differentiation and separation, is in fact the law of language and a sine qua non for the existence of desire. He claimed that the subject structures himself through his unconscious response to the law and to the incestuous desires it shapes to: the repression of desire (neurosis), and the denial or foreclosure of the law (perversion and psychosis, respectively). Lacan also showed that it is important to differentiate the real Father, the imaginary Father, and the symbolic Father.

PATRICK DE NEUTER

See also: Ego ideal/ideal ego; Fatherhood; Foreclosure; Myth of origins; Name-of-the-Father; Real, Symbolic, and Imaginary father; Sexuation, formulas of.

### **Bibliography**

- Collectif. (1989). *Le Père. Métaphore paternelle et fonction du père: L'interdit, la filiation, la transmission*. Paris: Denoël.
- De Neuter, Patrick. (1992). Le père réel et la sexualité du fils. *Psychiatrie de l'enfant*, 13, 65–80.
- . (1993). Fonctions paternelles et naissances du sujet. *Cahiers des sciences familiales et sexologiques*, 16, 105–127.
- Dor, Joël. (1989). *Le Père et sa Fonction en psychanalyse*. Paris: Point hors ligne.
- Freud, Sigmund. (1912–1913a). Totem and taboo. *SE*, 13: 1–161.

---

## **LAY ANALYSIS**

Lay analysis is psychoanalytic treatment carried out by someone who is not a physician. In a less common

sense, it is a treatment carried out by someone who has not received the necessary training in the practice of analysis. The term was first used by Freud in *The Question of Lay Analysis* (1926e), where he vigorously asserted that in the practice of psychoanalytic treatment, what mattered was good training, independent of diplomas obtained beforehand. He had already expressed a similar view in a preface to Eitingon's report (1923g) and in a preface to a book by Aichhorn (1925f).

On July 18, 1926, the newspaper *Neue freie Presse* published a letter from Freud correcting some inexact information regarding a lawsuit filed against Theodor Reik for the illegal practice of medicine. In it Freud reaffirmed that a nonphysician could be a psychoanalyst, citing both Reik and his daughter Anna Freud, but he added that he did not refer to such psychoanalysts cases that were serious or complicated by somatic factors. Freud had always held this position and asserted it since the beginning of the Vienna Psychoanalytic Society, to which he liberally admitted nonphysicians. In 1905 a member of the society, Max Graf, who was not a doctor, conducted, under Freud's direction, an "analysis" of his own son, "little Hans."

Thus the issue of lay analysis was raised early in the history of the psychoanalytic movement. Freud vigorously defended his position in 1926 because at that time the conflicts that developed around this issue took a serious turn. As a group Viennese psychoanalysts, among whom were a number of nonphysicians, supported Freud's position. In contrast, the Americans, under the influence of Abraham Arden Brill, wanted to bar the practice of analysis to anyone who was not a doctor. In Great Britain, Ernest Jones took a middle position, but mistrusted the nonphysicians, whom he thought must be carefully controlled. At issue in this debate were not only theoretical positions (is psychoanalysis a medical discipline, a therapy?), but also legal issues, which varied from country to country.

At the end of 1926, Ernest Jones and Max Eitingon organized a major discussion among members of the International Psychoanalytical Association so that a decision could be made on the issue at the Innsbruck congress planned for September 1927. There twenty-eight contributions (published by the two official organs of the association, the *Zeitschrift für Psychoanalyse* and the *International Journal of Psychoanalysis*)

were presented and discussed without an agreement being reached. The congress adjourned with a compromise: Each national society could follow its own policy. Jones emphasized the dangers of such a solution for the cohesion of the association, which was in fact on the verge of collapse over this issue and, some time later, over problems of training.

There were two aspects of the problem: training issues and theoretical issues. On the level of training institutes and their policies for the selection of candidates, France and other countries de facto aligned themselves with Freud's position. In contrast, the powerful American Psychoanalytic Association resolved to admit nonmedical analysts as late as 1988 only after long and costly legal battles. Weighing heavily on this question were factors of medical, psychological, and cultural history, of sociology, and of law that varied greatly from country to country.

On the level of theoretical justifications, two conceptions of psychoanalysis were opposed here. For some, psychoanalysis is a therapy that seeks to care for, and if possible cure, mental problems, even minor ones. Thus it can only be legitimately practiced by a doctor, preferably a psychiatrist, who has the necessary training to give a diagnosis and referral for analysis, and then to treat the patient with the broad-mindedness and accountability that doctors have. In France, Sacha Nacht defended this position. For others, however, analytic treatment is above all a personal experience, a liberation from the conflicts that restrict the ego and burden the mind, emotional life, and relations with others. Freedom and personal enrichment are the major aims, and any shortsighted preoccupation with a "cure" risks becoming an obstacle to good psychoanalysis. One could even argue that psychiatric training, which predisposes the physician toward diagnosis and treatment, is a handicap for the psychoanalyst. In psychoanalysis, the crucial references are cultural, even philosophical. In France, this last point of view was maintained, not exclusively but most brilliantly, by Jacques Lacan.

By 2005 the debate had largely quieted down. There seems to be general recognition that what is essential is good training in the theory and practice of analysis, especially the indispensable requirement of a personal analysis. But opinions continue to differ on what is the best preliminary training. In this respect, the debate is no longer over the question of physician versus nonphysician, but rather concerns the question of

psychiatrist or clinical psychologist. Quite possibly psychoanalysis will benefit from the confluence of these two other therapeutic traditions.

ROGER PERRON

*See also:* American Psychoanalytic Association; International Psychoanalytic Association; National Psychological Association for Psychoanalysis; *Question of Lay Analysis, The*; Reik, Theodor; Schweizerische Ärztgesellschaft für Psychoanalyse; Training of the psychoanalyst.

### **Bibliography**

Freud, Sigmund. (1923g). Preface to Max Eitingon's *Report on the Berlin Psycho-analytical Polyclinic*. *SE*, 19: 285.

———. (1925f). Preface to Aichhorn's *Wayward youth*. *SE*, 19: 271–275.

———. (1926e). The question of lay analysis. *SE*, 20: 179–258.

Jones, Ernest. (1957). Lay analysis. In his *Life and work of Sigmund Freud*. Vol. 3: *The Last Phase, 1919–1939*. New York: Basic Books.

Perron, Roger. (1990). Médecins et non-médecins dans l'histoire de la Société psychanalytique de Paris. *Revue internationale d'histoire de la psychanalyse*, 3, 167–198.

---

## **LEARNING FROM EXPERIENCE**

*Learning from Experience* was Wilfred Bion's first major venture into metapsychology and epistemology. In this work he set out to specify how normal and psychotic minds function. To accomplish his mission, he defines certain ideas as tools of understanding. He defines a "factor" as a mental activity that is a subset, along with other factors, of a "function." "Factors are deduced not directly but by observation of functions," he claims.

The particular function that he explicates in this work, one that he elaborates throughout his later works, is the alpha function, so named to preserve it from contamination by a penumbra of preconceptions and other associations. In the course of developing his ideas about how alpha functions work, he adds an idea borrowed from Freud (1911b) "A special function was instituted which had periodically to search the external world, in order that its data might be familiar already if an urgent internal need should arise—the function of *attention*" (p. 220). "Freud did not carry his investigation of attention far, but the term, as he uses it, has a meaning I would investigate as a factor in alpha-function."

Attention—and later notation, inquiry, and action—thus became factors in alpha-functioning. Later they became the components of the horizontal axis of his grid.

Bion frequently returns to Freud's two principles of mental functioning, the pleasure principle and the reality principle, and seems to reason that distinguishing them as primary and secondary processes is artificial in terms of the sense organ of attention that apprehends them. Consequently, he designates the alpha function as the sense organ of attention for each principle. He then introduces the factors of beta elements, the unprocessed sense impressions that require the activity of the alpha function to transform (render, metabolize) them into alpha elements suitable for mental processing into memory, dream elements, and thoughts. He came to this idea from his experiences with psychotic patients: "The attempt to evade the experience of contact with live objects by destroying alpha-function leaves the personality unable to have a relationship with any aspect of itself that does not resemble an automaton. Only beta-elements are available for whatever activity takes the place of thinking and beta-elements are suitable for evaluation only—perhaps through the agency of projective identification" (1962, p. 13).

To explain the motivation for seeking to learn from experience, Bion gives the K (knowledge) link the same, if not greater, status as the L (love) and H (hatred) links. He clearly makes a triad out of Freud's instinctual drives and Klein's epistemological instinct and transforms them from instinctual drives into subject-object linkages, with K as the leader.

Following this, he discusses the need to correlate samples from all the sense organs as one form of "common sense," in addition to the "sense organs" from both the self and the other (the analyst) as "second opinion." When these correlations are made, abstraction from them and "publication" (allowing oneself to know them and act upon them) become possible. The complementary functioning of consciousness and the unconscious as sense organs is most clear in the following passage:

The theory of consciousness is weak, not false, because by amending it to state that the conscious and unconscious thus constantly produced together to function as if they were binocular therefore capable of correlation and self-regard. . . . For these reasons and others arising from clinical experience of psychoanalysis of that

class of patient in whom the psychotic part of the personality is obtrusive, I find the theory of primary and secondary processes unsatisfactory. This theory is weak in the need to postulate two systems at the point where, in my theory of an alpha-function, an emotional experience is transformed into alpha-elements, to make dream thought, unconscious waking thinking and storage in the mind (memory) possible. I attribute the appearance of beta-elements, the closely associated bizarre objects and the serious disturbances ordinarily associated with excessive obtrusion of the psychotic elements of the personality, to the failure of alpha-function.

Bion thereupon develops the idea that the alpha function gives rise to abstraction and the progressive realizations that abstractions enable the subject to have: “The concrete statement might be: breast exists that can be depended on to satisfy his hunger for food; abstraction from this might be: there is something that can and does give him what he wants when he wants it.”

Still later Bion considers the notion of the selected fact. He states that the selected fact coheres the objects of the paranoid-schizoid outlook and thereby makes possible the onset of depression and does so by its membership in a number of deductive systems. He goes on to state, “The relationship between mother and infant described by Melanie Klein as projective identification is internalized to form an apparatus for regulation of a pre-conception with the sense data of the appropriate realization. This apparatus is represented by the model: the mating of pre-conception with sense impression to produce a conception. This model is in turn represented by ♂ ♀ . . . . The repetition of mating of pre-conception and sense data, that results in commensal abstraction, promotes growth in ♂ ♀. That is, the capacity for taking in sense impressions develops together with the capacity for awareness of sense data.”

Finally, Bion returns to the K link and, in light of his experiences with psychotic patients, contrasts it with the –K link, that which denudes the sense data of meaning to prevent realizations from developing.

JAMES S. GROTSSTEIN

See also: Grid; Love-Hate-Knowledge (L/H/K links); Primal, the; Protothoughts.

### Source Citation

Bion, Wilfred. (1962). *Learning from experience*. London: Heineman; New York: Basic Books.

### Bibliography

Freud, Sigmund. (1911b). Formulations on the two principles of mental functioning. *SE*, 12: 213–226.

## LE BON, GUSTAVE (1841–1931)

Gustave Le Bon, a French physician and philosopher, was born in 1841 in Nogent-le-Rotrou and died on December 24, 1931, in Paris. Le Bon's name has for years been associated with *The Crowd* (1895/1995), which made him one of the founders of group psychology. In spite of, or perhaps because of, the book's phenomenal success—it has been translated into several languages and was reprinted many times—Le Bon has been disparaged and misunderstood by the scientific community. He has been reproached for the summary, polemical, even reactionary nature of his analysis. A prophet and harsh critic of mass society, he ushered in the “age of the crowd,” “the most recent sovereign of the modern age.”

The son of a civil servant, this country doctor developed an early interest in anthropology, then sociology and psychology. A tireless worker, he made a living as a writer and editor. Although he was never an academic, he was well known, much more so than someone like Emile Durkheim. Government officials, writers and scientists attended his “lunches”: Théodule Ribot, Bergson, Valéry, Henri and Raymond Poincaré, Aristide Briand, and Marie Bonaparte, who introduced him to the work of Sigmund Freud and who remained Le Bon's friend until his death.

In 1902, Le Bon began editing a collection of scientific works for Flammarion, the “Bibliothèque de philosophie scientifique,” intended for the lay reader. The series had considerable success. He published the majority of his own writings as part of the collection, as well as Henri Poincaré's *La Science et l'Hypothèse* and Marie Bonaparte's *Guerres militaires et Guerres sociales*.

Taine's influence on Le Bon was considerable, but so was that of Ribot and Charcot. All of Le Bon's work bears the mark of the intellectual climate of fin-de-siècle France: an attraction to the irrational, the primacy of feeling over reason, and the role of heredity and race.

Freud read Le Bon and was directly inspired by him in writing *Group Psychology and the Analysis of the Ego*

(1921c). Like Le Bon he sought to explain the phenomena of collective life through individual psychology. But Freud eliminated the notions of heredity, mentality, and suggestion and replaced them with a model of unconscious identification. Le Bon's idea of the unconscious as an archaic heritage of the human soul was closer to Jung than to Freud. Their ideas of the social also diverged. Freud wanted to clarify the irrationality of the group in order to reduce it, while Le Bon appeared to systematically cultivate it.

ANNICK OHAYON

See also: Bonaparte, Marie León; *Christians and Jews: A Psychoanalytical Study*; Fascination; *Group Psychology and the Analysis of the Ego*; Otherness; Suggestion.

### Bibliography

Le Bon, Gustave. (1910). *La psychologie politique et la défense sociale*. Paris: Flammarion.

———. (1980). *The French Revolution and the psychology of revolution*. With a new introduction by Robert A. Nye. New Brunswick, NJ: Transaction Books. (Original work published 1912)

———. (1995). *The crowd*. With a new introduction by Robert A. Nye. New Brunswick, NJ: Transaction Books, c1995. (Original work published 1895)

Freud, Sigmund. (1921c). Group psychology and the analysis of the ego. *SE*, 18: 65–143.

## LEBOVICI, SERGE SINDEL CHARLES (1915–2000)

Serge Lebovici, a French psychiatrist and psychoanalyst, was a professor emeritus of child psychiatry and an officer of the Legion of Honor. He received the Croix de Guerre for service in 1939–1945. He was born June 10, 1915, in Paris, and died August 12, 2000, in Marvejols in the south of France.

His father was Solo Lebovici, a well-known general practitioner and specialist in dermatology. A Romanian Jew, he emigrated to France in 1904. His mother, Caroline Rosenfeld, was from a Jewish family from Alsace. Lebovici began his medical training in 1933. After being admitted as an intern at the Hôpitaux de Paris in 1938, he was forced to interrupt his studies between 1938 and 1941. After his military service he was mobilized during the “phony war,” then spent time as a prisoner of war in Nuremberg. After being

freed, along with his father, in January 1941, he completed his doctoral dissertation and in 1942 married Ruth Roos. They had two daughters, Marianne, born in 1943, and Elisabeth, born in 1953. In August 1942, his father was arrested by the Nazis after being denounced but managed to save his wife by passing her off as his part-time mistress. After spending time in the camp of Pithiviers, he was deported to Drancy on September 23 and died in Auschwitz.

Lebovici, who worked for a time with the Assistance Publique, where he was protected by professors Paul Milliez and Raoul Kourilsky, cared for his mother and two sisters, along with his wife and first daughter. He soon made contact with communist members of the Resistance, to whom he provided medical assistance. He became a member of the French Communist Party at the time of the Liberation, in 1945, when he joined the army. There he met another French Resistance member, Sacha Nacht, who was also of Romanian origin, and began psychoanalysis with him before participating in the reconstruction of the French psychoanalytic movement, which had stalled during the Occupation.

Lebovici specialized in child psychiatry. As an assistant to the department of child psychiatry with Professor Heuyer from 1946 to 1957 at the Hôpital des Enfants Malades (Hospital for sick children), then at the Salpêtrière Hospital, he helped train an entire generation of psychoanalytically oriented child psychiatrists. During the post-war period, still under the influence of communist theories, he insisted on the socio-economic origin of child disturbances and, in 1949, cosigned the antipsychoanalytic manifesto published by *La Nouvelle Critique*. It required Communist Party psychiatrists to follow the recommendations of Zhdanov throughout the Cold War. However, along with his friends Jean and Evelyne Kestenberg and Salem Shentoub, he soon renounced the manifesto and quit the French Communist Party to devote himself to psychoanalysis.

Made an associate member of the Société psychanalytique de Paris (Paris Psychoanalytic Society) (SPP) in 1946, he became a full member in 1952, the same year as René Diatkine, who remained his close friend. Lebovici and Diatkine together contributed to the creation of a number of institutions, which imparted some of Lebovici's originality to the French psychoanalytic movement. In 1948 they adapted the practices of Jacob Moreno for use in “psychoanalytic psychodrama” to treat child and adolescent psychoses. During the 1953 split, Lebovici sided with Sacha Nacht against Jacques Lacan

and the cofounders of the Société française de psychanalyse (French Psychoanalytic Society), arguing for theoretical and institutional “orthodoxy,” a position that won many friends and created many lasting enemies.

In 1961, on behalf of the Mental Health Association of the thirteenth arrondissement of Paris, formed in 1958 by Philippe Paumelle, Lebovici and Diatkine created the Centre Alfred-Binet for child and adolescent psychiatry. This pioneering institution promoted a new multidisciplinary approach to psychiatry in which psychoanalysis had a preponderant role. One offshoot of this was the review *La Psychiatrie de l'enfant*, which he began in 1958 with the help of Julian de Ajuria-guerra and René Diatkine.

Lebovici was made secretary of the Institut de psychanalyse de Paris (Paris Institute for Psychoanalysis) at the time of its creation in 1952, then director from 1962 to 1967. He made it possible for non-doctors to become accredited psychoanalysts, which Sacha Nacht, his predecessor, had opposed (enabling Evelyne Kestemberg to become a member in 1963). Along with his private practice his activities within the SPP were ongoing and varied; they included numerous conferences, colloquia, seminars, and supervisory activities. Internationally he helped train and organize psychoanalysts, and at home helped popularize the work of Anna Freud, Melanie Klein, René Spitz, and Donald Winnicott, whom he brought to Paris. Because of his work he was elected vice-president of the executive board of the International Psychoanalytic Association in 1967 and made president in 1973. He was the first person of French nationality to hold that position, but he was later reproached for not having been severe enough with a Brazilian teaching analyst whose student, a doctor, had participated in the torture of political prisoners. At the end of his term, in 1977, he was appointed associate professor at the University of Paris-North, in Bobigny. The following year he created a department of child psychiatry at the Avicenne Hospital.

Lebovici was world renowned in the field of child psychoanalysis and published a large number of books and papers (nearly five hundred bibliographic references). These include *La Connaissance de l'enfant par la psychanalyse*, published in 1975 with Michel Soulé, a friend who also contributed, along with René Diatkine, to the 1985 *Traité de psychiatrie de l'enfant et de l'adolescent*. These early publications contain a sketch of his future interest in the direct observation of infants. He was also involved in the study of autism and the use of psycho-

analysis to treat psychotic children. His work culminated in the publication, in 1960, with Joyce McDougall, of *Un cas de psychose infantile: Étude psychanalytique*.

In France he became one of the principal initiators of the direct observation of early interactions between mother and child. In this he drew from the work of John Bowlby (the theory of attachment), T. Berry Brazelton (neonatal competence of the baby), and Daniel Stern (affective tuning), authors whom he introduced to French clinicians working with young infants. In 1983 he published, together with Serge Stoléru, *Le Nourrisson, la mère et le psychanalyste: Les interactions précoces*, a book that marked the start of perinatal clinical research in France. In 1989 he edited, with Françoise Weil-Halpern, *La Psychopathologie du bébé*. In these two books the complexity of behavioral interaction—affective and fantasy—between mother, father, and infant in the development of early bonds is explored and innovative therapeutic approaches are introduced. In his work on parent-child interactions, Lebovici introduced an original approach that combined the French psychoanalytic tradition with Anglo-American developmentalism. In it he emphasized the intergenerational transmission of parental infantile conflicts and the reciprocity of inherent narcissistic transactions. Although he did not overlook the contributions of experimental psychology, ethology, or the neurosciences, he felt that an understanding of the process of parenthood required a psychological component that took into account the imaginary, fantasy, mythic, and narcissistic representations of the developing child. In his last works Lebovici developed the concept of “enaction” to describe the analyst’s emotional and physical trial in the presence of the mother and child during therapy and that of “metaphor-generating empathy” to signify his ability to verbalize and represent their affects during therapeutic sessions involving the parents and the child.

President of the International Association for Child and Adolescent Psychiatry and Allied Professions (IACAPAP) from 1966 to 1970, then of the World Association of Infant Psychiatry and Allied Disciplines (WAIPAD, now the WAIMH), Lebovici held a number of important functions in international organizations in his field. In spite of the increasing demands made on him by Parkinson’s disease, which served to isolate a man whose entire life had expressed a need for communication, until the end of his life Lebovici participated in the work of the psychoanalytic institutions he had always been involved with. He was made

honorary vice president of the International Psychoanalytic Association and honorary president of the International Association of Child and Adolescent Psychiatry.

An able manager, a humanist who loved music, a man with a curious mind who was always in search of new areas of research and activity, Lebovici played a role in the leading innovations in psychoanalysis of the second half of the twentieth century.

ALAIN DE MIJOLLA

*Notion developed:* Prepsychosis.

*See also:* Anaclysis/anaclytic; Analytic psychodrama; Brazil; Centre Alfred-Binet; Child analysis; Colloque sur l'Inconscient; Congrès des psychanalystes de langue française des pays romans; Dependence; Developmental disorders; Diatkine, René; Early interactions; Ethology and psychoanalysis; France; Hospitalism; Indications and contraindications for psychoanalysis in an adult; Infant development; Infantile neurosis; Infantile schizophrenia; Infantile, the; Inter-generational; International Psychoanalytical Association; Nacht, Sacha Emanouel; Narcissism, primary; Object; Oedipus complex; Phobias in children; Reverie; Société psychanalytique de Paris and Institut de psychanalyse de Paris; Stranger; Tics; Transference in children.

### **Bibliography**

- Coblence, F. (1996). *Serge Lebovici*. Paris: Presses Universitaires de France.
- Lebovici, Serge. (1983). *Le Nourrisson, la mère et le psychanalyste*. Paris: Le Centurion.
- . (1989). *Psychopathologie du bébé*. Paris: Presses Universitaires de France.
- Lebovici, Serge, and Soulé, Michel. (1970). *La connaissance de l'enfant par la psychanalyse*. Paris: Presses Universitaires de France.
- Lebovici, Serge, Diatkine, René, and Soulé, Michel. (1995). *Nouveau traité de psychiatrie de l'enfant et de l'adolescent* (2nd ed.). Paris: Presses Universitaires de France.
- Mijolla Alain de. (1988). "Psychoanalysis and psychoanalysts in France between 1939 and 1945", *Int Forum Psychoanalysis*, 12, 136–156, 2003, Stockholm.

## **LECHAT, FERNAND (1895–1959)**

Fernand Lechat, a Belgian industrial psychologist with the Center for Applied Psychology and a psychoanalyst, was born at Mont-sur-Marchienne in 1895 and died in Brussels in 1959. He and Maurice Dugautiez

were among the first to promote psychoanalysis in Belgium. His religious, middle-class family wanted him to become a priest.

During World War I he enrolled in the air force as a volunteer. After the war he divided his energies between a prosperous insurance business and poetry. During this time he became a fervent believer in depth psychology and devised a personality test based on color selection. His first wife died. Then, following a difficult mourning period, he met a young teacher who became his second wife. She worked alongside him and encouraged him through all their years together.

After meeting with Maurice Dugautiez in 1933, he burned all his poetry and turned his back on his growing insurance business to devote himself entirely to his psychoanalytic training. In the course of his training analysis with Dr. Ernst Hoffman, a Viennese refugee in Belgium, he became a specialist on the Rorschach test and character examination in industrial psychology.

After the end of World War II he resumed his training at the Paris Psychoanalytic Institute. Having been recognized as a training analyst in 1946, he devoted himself, with his wife, to training analysis, and in 1947 he founded the Association des psychanalystes de Belgique (Association of Belgian Psychoanalysts), along with Maurice Dugautiez. He also launched the association journal, *Bulletin de l'Association des psychanalystes de Belgique*, and expanded its circulation to an international level. As president of the the association, he organized the twentieth Congress of Romance-Language Psychoanalysts in Brussels in 1958, the first congress of its kind to be held in Belgium.

An active participant at many congresses and meetings of the Société psychanalytique de Paris (Paris Psychoanalytic Society), he won many friends with his enthusiasm and jovial character. Of all his highly eclectic psychoanalytic work, he is mainly known for his report "The safety principle," presented at the seventeenth Conference of Romance-Language Psychoanalysts in November 1954.

DANIEL LUMINET

*See also:* Belgium ; Dugautiez, Maurice.

### **Bibliography**

- Lechat, Fernand. (1952). *Jamais deux sans trois*. *Revue française de psychanalyse*, 17 (4), 518–540.

———. (1955). Du principe de sécurité. (rapport). *Revue française de psychanalyse*, 19 (1–2), 11–101.

———. (1956). Notes sur les premières relations objectales et leurs conséquences à l'âge adulte. *Bulletin de l'Association des psychanalystes de Belgique*, 14.

## LECLAIRE (LIEBSCHUTZ), SERGE (1924–1994)

A French psychiatrist and psychoanalyst, Serge Leclaire (born Liebschutz) was born in Strasbourg on July 6, 1924, and died of a brain hemorrhage on August 8, 1994, in Argentière, Savoy in France.

Leclaire was born into an old Alsatian family of liberal Jews who changed their name to Leclaire and took refuge in central France during the Second World War. He studied medicine and psychiatry in Paris. In 1957, he defended his dissertation in medicine, *A Contribution to the Study of the Principles for a Psychotherapy of the Psychoses*.

From 1949 to 1953 he undertook an analysis with Jacques Lacan, and in 1953, he was involved in the protest of the trainees against the leadership of the *Société psychanalytique de Paris* (SPP; Paris Psychoanalytic Society). When that group split, he left to join the *Société française de psychanalyse* (SFP; French Psychoanalytic Society), where he was made an associate member in 1954 and served as secretary from 1957 to 1962. He became president of the society in 1963, the year of the second split of the French psychoanalytic groups. In the years leading up to that split, Leclaire, Wladimir Granoff, and François Perrier (known as the “troika”) participated in the attempt to get the SFP recognized by the International Psychoanalytic Association (IPA), but the effort ultimately failed.

With François Perrier and Françoise Dolto, he took the side of Jacques Lacan in the second split and was a member of the first board of directors of the *École Freudienne de Paris* (EFP; the Freudian school of Paris), which was founded that same year. But he also remained an independent member of the IPA until 1967. Although he was very active in the EFP at the outset, he increasingly withdrew in order to reflect on the function of the analyst in society and to produce a profoundly original body of work. While remaining faithful to Freud's text (he was a German scholar), Leclaire interrogated the Freudian clinic from a Lacanian perspective. In 1968, he published his first book, *Psychoanalyzing*, which won a wide audience thanks to

its clarity and readability, but also because it showed what the Lacanian “clinic of the signifier” could be in a detailed reading of “The Dream with the Unicorn” (1968/1975).

Maintaining his independence both from the EFP and the growing dogmatism that characterized its development, Leclaire wanted to take psychoanalysis outside of the usual institutional settings. In 1968, he founded the first university department of psychoanalysis within the framework of the experimental center at Vincennes. He resigned in 1970. Later he was at the forefront of a critique of the Freudian School and especially of Lacan's procedure of the “pass.” He also worked with feminists, notably Antoinette Fouque.

His last contribution to psychoanalysis was “A Proposal for a Regulating Institution for Psychoanalysts,” which was published in *Le Monde* on December 15, 1989, and cosigned by four friends and colleagues, Lucien Israel, Philippe Girard, Danièle Lévy, and Jacques Sédat. But the proposal was misunderstood and badly received. Still, in January 1990, Leclaire and his co-signatories founded the *Association pour une Instance Tierce des Psychanalystes* (APUI; Association for a third institution of psychoanalysts). Leclaire served as president of APUI until his death. The last project he undertook was the publication of his final book, *The Land of the Other*, in 1991.

Serge Leclaire trained numerous analysts, both as a training analyst and a supervisor. Because of his unique position and his intellectual openness, he was able to maintain friendly relations with numerous colleagues from different schools in spite of splits and divisions.

JACQUES SÉDAT

*See also:* *Bloc-Notes de la Psychanalyse*; Colloque sur l'inconscient; Doubt; École freudienne de Paris (Freudian school of Paris); Erotogenicity; France; Granoff, Wladimir Alexandre; Pass, the; Perrier, François; Société française de psychanalyse; Structuralism and psychoanalysis.

### Bibliography

Leclaire, Serge. (1971). *Démasquer le réel*. Paris: Seuil.

———. (1981). *Rompre les charmes*. Paris: InterÉditions.

———. (1991). *État des lieux de la psychanalyse* (In collaboration with APUI). Paris: Albin Michel.

———. (1998). *A child is being killed: On primary narcissism and the death drive*. (Marie-Claude Hays, Trans.). Stanford,



CA: Stanford University Press. (Original work published 1975)

———. (1998). *Écrits pour la psychanalyse*. Paris: Le Seuil-Arcanes.

———. (1998). *Psychoanalyzing: On the order of the unconscious and the practice of the letter* (Peggy Kamauf, Trans.). Stanford, CA: Stanford University Press. (Original work published 1968)

### Further Reading

Mijolla, Alain de. (2001). Splits in the French psychoanalytic movement between 1953 and 1964. In R. Steiner and J. Johns (Eds.), *Within Time and Beyond Time, A festschrift for Pearl King* (pp. 1–24). London: Karnac. (Original work published 1995)

---

## LEEuw, PIETER JAKOB VAN DER (1909–1985)

Pieter Jakob van der Leeuw, a psychiatrist and psychoanalyst, was born in Zutphen, the Netherlands on July 9, 1909, and died in Amsterdam on November 20, 1985.

He was the first child of a family of five children and grew up in difficult circumstances since his father, an engineer, died when he was 12 and his mother had to run the family alone. He studied medicine in Utrecht and chose his specialization as a psychiatrist in the same town.

His psychoanalytic training took place in Amsterdam during World War II, with Jeanne Lampl-de Groot as his training analyst. He was chairman of the Dutch Society and of the Training Committee, and one of the founders of the Psychoanalytic Institute in Amsterdam in 1946. Internationally he made an effort after World War II to re-establish contacts between analysts in different countries. He was one of the initiators of the Arbeitstagung (Working Group) and of the European Psychoanalytical Federation of which he was vice-president for some years before being elected president of the International Psychoanalytical Association (1965–1969). Besides that he was co-founder of the Sigmund Freud Museum, Berggasse 19, in Vienna (1969). He achieved honorary membership in the Societies of Venezuela (1970), Vienna (1972), and the Netherlands (1979).

Van der Leeuw was a great scholar of Freud's writings. The development of theories by Freud had his special interest. In his publications he explained what he thought Freud meant by his concept of metapsy-

chology, and emphasized the importance of the quantitative point of view (1969). He felt very much involved, through his four-year experience as IPA president, in the sources of the conflicts between the component Societies (1968). In his article about the Freud-Jung correspondence (1977), he explains in more detail the basic problems for followers of Freud.

Van der Leeuw made contributions of his own to the clinic of psychoanalysis in his publication about the preoedipal phase of the male (1958) and the concept of defense (1971).

Van der Leeuw is remembered by his colleagues as an erudite and earnest person, self-disciplined in his profession and very much dedicated to the cause of psychoanalysis.

ELISABETH VERHAGE-STINS

See also: International Psychoanalytical Association; Netherlands.

### Bibliography

Leeuw, Pieter Jakob van der. (1958). On the preoedipal phase of the male. *International Journal of Psycho-Analysis*, 39, 112–115.

———. (1968). The psychoanalytic society. *International Journal of Psycho-Analysis*, 49, 160–164.

———. (1969). Concernant le concept de défense. *Revue française de psychanalyse*, 33, 5–23.

———. (1971). On the development of the concept of defence. *International Journal of Psycho-Analysis*, 52, 51–58.

———. (1977). L'impact de la correspondance Freud-Jung sur l'histoire des idées. *Revue française de psychanalyse*, 41, 439–463.

---

## LEHRINSTITUT DER WIENER PSYCHOANALYTISCHE VEREINIGUNG

On May 22, 1922, having learned from his experience of the two-year-old Berlin psychoanalytic polyclinic, Eduard Hitschmann inaugurated the Ambulatorium or psychoanalytic dispensary as director in the premises of the Vienna polyclinic, not far from Vienna's AHK General Hospital. This creation was the realization of Freud's dream of making psychoanalysis accessible to populations with modest incomes, but an administrative measure threatening to close the estab-

lishment allowed only medical doctors to practice there. Each physician in the Vienna Society had to contribute at least one free analysis.

Lectures were given periodically. Early topics included "Introduction to Psychoanalysis," by Eduard Hitschmann; and "What Every Practicing Physician Should Know about Psychoanalysis," by Felix Deutsch. Later topics included "Psychoanalysis for Beginners," from Paul Federn; "The Theory of the Libido," from Ludwig Jekels; "The Theory of Neuroses," from Hermann Nunberg; "The Sexual Perversions," from Isidor Sadger; "Clinical Psychoanalysis," from Wilhelm Reich; "Occupational Neuroses," from Robert Jokl; "Religion and Obsessional Neurosis," from Theodor Reik; and "Psychoanalysis and Psychiatry," from Paul Schilder.

In 1924 a center was set up for infantile guidance—for children and adolescents—directed by Hermine von Hug-Hellmuth. In 1932, with August Aichhorn as president, it opened its doors to Wilhelm Hoffer, Kurt R. Eissler and Editha Sterba. In 1929 Paul Schilder created a department for borderline patients and psychotics, before being replaced by Edward Bibring. When there was a sufficient number of participants, parallel English classes were organized.

In 1925, three years after the Ambulatorium, the training institute of the Vienna Society was created to provide theoretical and practical training under the direction of Helene Deutsch, Anna Freud, and Siegfried Bernfeld. The committee consisted of Paul Federn, Hermann Nunberg, Wilhelm Reich, and Eduard Hitschmann. The training program for the last winter semester before the closure of all psychoanalytic institutions (October 1, 1937 to February 28, 1938) included mandatory courses for candidates, including five or even six hours of lectures on theoretical psychoanalysis. These lectures included: "A Study of Instincts," by Otto Isakower; "A Study of Dreams," by Richard Sterba; "The Psychology of the Ego," by Heinz Hartmann; "A General Study of Neuroses," by Otto Fenichel; "A Study of the Specific Neuroses," by Eduard Hitschmann; and "Technical Problems," by Jeanne Lampl-de Groot.

Over the course of its brief existence, a number of important events occurred at the Lehrinstitut as well:

- Seminars included "Reading Freud," led by Edward Bibring and Paul Federn; "Analyzing

Children," led by Anna Freud; and "Control Analyses," led by Grete Bibring-Lehner.

- Conferences included "The Process of Ego Cathexis," led by Paul Federn; and "Dream Symbolism in Analytic Sessions," led by Maximilian Steiner.
- There were several work groups: Paul Federn and Erwin Stengel's "The Psychoanalysis of Psychoses"; Heinz Hartmann and Willi Hoffer's "Reading Freud's Writings" (for members of the Wiener Verein für medizinische Psychologie [Viennese Association for Medical Psychology]); and Edward Bibring, Heinz Hartmann, Willi Hoffer, and Ernst Kris's "The Scientific Work Group."
- Among the symposia given were "The Practice of Analyzing Abandoned Youth," by August Aichhorn; "Analyzing Children," by Berta Bornstein; "Fundamental Concepts in Psychoanalytic Theory," by Otto Fenichel; "On Dreams," by Ernst Kris; "Problems of Analysis at Puberty," by Editha Sterba; "The Theory of Therapy," by Richard Sterba; and "Interviews on Specific Analytic Situations," by Jenny Waelder.
- Specific lectures were given for teachers and teacher associations, among them, "Introduction to Pedagogical Consultation," by August Aichhorn; "Anxiety in Children," by Grete Bibring; "The Limits of Psychoanalytic Pedagogy," by Dorothy Burlingham; "Course Questions," by Edith Buxbaum; "Educating, Playing, Teaching," by Willi Hoffer; "Specific Children's Disorders," by Editha Sterba; and "On Psychoanalytic Psychology," by Richard Sterba. There were likewise seminars for professional educators, including "Seminar for Pedagogical Advisers," by August Aichhorn; and "Reading Freud's Writings," with Grete Bibring, Berta Bornstein, Hedwig Hoffer-Schaxel, Willi Hoffer, Marianne Kris, Jeanne Lampl-de Groot, and Richard Sterba.

The training institute and all other institutes of the Wiener psychoanalytische Vereinigung (WPV) were shut down in March 1938, after the annexation of Austria by the Third Reich.

EVA LAIBLE

*See also:* American Psychoanalytic Association; International Psychoanalytical Association; Austria; Berliner Psychoanalytisches Institut; Deutsch-Rosenbach, Helene; Göring, Matthias Heinrich; Hitschmann, Eduard;

Technique with children, psychoanalytic; *Psychoanalytical Treatment of Children, The*; Wiener psychoanalytische Vereinigung.

### **Bibliography**

Hitschmann, Eduard. (1932). A ten years report of the Vienna Psycho-Analytical Clinic. *International Journal of Psycho-Analysis*, 245–255.

Mühlleitner, Elke. (1992). *Biographisches Lexikon der Psychoanalyse (Die Mitglieder der Psychologischen Mittwoch-Gesellschaft und der Wiener Psychoanalytischen Vereinigung 1902–1938)*. Tübingen: Diskord.

Wiener psychoanalytische Vereinigung. (1937). *Lehrkurse und Veranstaltungen Wintersemester 1937-1938, Programm*. Wien: Lehrausschuss der Wiener psychoanalytischen Vereinigung.

---

## **LEHRMAN, PHILIP R. (1895–1958)**

Philip R. Lehrman was born in Plissa in Russia on October 12, 1895, and died in New York on February 4, 1958. He was the fifth of seven children in a family that emigrated to the United States in 1905. An excellent student Lehrman graduated from Fordham University Medical School in 1918. While working at the St. Lawrence State Hospital in Ogdensburg, New York, he met Abraham Arden Brill, who became a lifelong friend and mentor. He joined the New York Psychoanalytic Society in 1921 where he served for many years on the educational committee and board of directors. He was secretary of the Society from 1935 to 1944 and president in 1946. Lehrman was also a professor of clinical psychiatry and neurology at Columbia University and New York University.

In 1928 Lehrman traveled with his wife, Wanda Scheps, who was from Vienna, and their two children, Howard and Marilyn, to Vienna for a year of analytic work with Freud. He took part in the meetings of the Vienna and Berlin societies, where he met the analysts from the Tegel clinic and the Polyclinic. Lehrman was an amateur cinematographer and filmed Freud and his colleagues with a Bell and Howell camera during his year in Vienna. His films are documents of inestimable value for the history of psychoanalysis. These films were edited by his daughter, Lynne Wiener-Lehrman, in 1986 and are the subject of a forthcoming book.

Lehrman wrote about thirty articles and was the editor of Anna Freud and Dorothy Burlingham's 1943

book *War and Children* and, in 1948, also edited Brill's *Basic Principles of Psychoanalysis*.

Among his students were Louise Gordy, Ruth Loveland, and Sidney Klein.

MICHELLE MOREAU RICAUD

*See also:* Cinema and psychoanalysis; New York Psychoanalytic Institute; United States.

### **Bibliography**

Lehrman, Philip R. (1927). The fantasy of not belonging to one's family. *Archives of Neurology and Psychiatry*, 18, 1015–1023.

———. (1939). Some unconscious determinants in homicide. *Psychoanalytic Quarterly*, 13, 605–621.

———. (1948). A. A. Brill in American Psychiatry, *Psychoanalytic Quarterly*, 17 (2), 155–160.

———. (1951). Fritz Wittels, 1880–1950. *Psychoanalytic Quarterly*, 20 (1), 96–104.

---

## **LEONARDO DA VINCI AND A MEMORY OF HIS CHILDHOOD**

This monograph on Leonardo da Vinci was the first of this kind written by Freud, and he had great reservations about it. There were precedents, however: Isidor Sadger had written several histories of artists with pathologies (Conrad-Ferdinand Meyer, Nikolas Lenau, Heinrich von Kleist). For years Freud had been interested in Leonardo da Vinci (see his letter to Wilhelm Fliess of October 9, 1898) and identified with Leonardo's passion for investigation and the nature of his research, which created a scandal at the time. Leonardo da Vinci and his ilk—Francis Bacon, Nicolas Copernicus, Bernard Palissy—are heroes of scientific research, men who have “troubled the world's sleep” (Friedrich Hebbel).

The first of the book's six chapters discusses the passion for investigation, its infantile origins, and its drawbacks from the point of view of love, social relations, and other activities. Leonardo is a good example of such behavior because he allows Freud to contrast the inhibition (the slowness of execution) characteristic of his painting with his excessive investment in research. Freud defines the three outcomes of infantile sexual investigation: inhibition, obsession, sublimation. “[L]ibido evades the fate of repression by being sublimated at the very beginning into curiosity” (p. 79).

The second chapter is devoted to Leonardo's memory of his childhood. Freud interprets the memory as a fantasy and compares it with mythological information. Unfortunately, Freud's discussion is not pertinent, because a translation error leads him to talk about a vulture instead of a kite.

The third chapter provides a description, based on the fantasy of fellatio expressed in the memory, of a particular type of homosexuality. In this type of homosexuality, the subject identifies with his mother so he can experience self-love through other young men, objects of his homosexual choice. This discussion considers narcissistic choice long before Freud introduced the concept of narcissism.

In chapter 4 Freud continues his discussion of the memory of Leonardo's mother in his analysis of Mona Lisa's smile. Chapter 5 describes Leonardo's antagonism toward his father. Freud saw in this antagonism the origin of Leonardo's courage as an investigator, primarily in the face of religious authority. Chapter 6, which contains an important discussion of the role of chance, presents Freud's methodological conclusion on creativity.

Freud's essay on Leonardo is one of his best known works. Though Freud quotes several biographies of artists, he transforms the art form by investigating the obsessive investment associated with sublimated activity.

SOPHIE DE MIJOLLA-MELLOR

*See also:* Applied psychoanalysis and the interaction of psychoanalysis; Eissler, Kurt Robert; History and psychoanalysis; Homosexuality; Identification; Intellectualization; Knowledge or research, instinct for; Literary and artistic creation; Memory; "On Narcissism: An Introduction"; Phallic mother; Phallic woman; Visual arts and psychoanalysis; Psychobiography; Psychohistory; Repetition; Sublimation; Thought.

### Source Citation

Freud, Sigmund. (1910c). *Eine Kindheitserinnerung des Leonardo da Vinci*. Leipzig: F. Deuticke; G.W., vol. 8, pp. 127–211. Leonardo da Vinci and a memory of his childhood. *SE*, 11: 57–137.

### Bibliography

Barande, Ilse. (1977). *Le maternel singulier: Freud et Léonard de Vinci*. Paris: Aubier-Montaigne.

Eissler, Kurt R. (1961). *Leonardo da Vinci*. New York: International Universities Press.

## LETTER, THE

The letter refers to the material substrate, identical to the printed character, that serves as the vehicle for spoken or written language. It represents the two sides of the signifier (metaphor and metonymy) in the creation of meaning and in the production of dreams, where the letter designates one of the terms of the rebus. As the localized structure of the signifier, the letter's nature is real, exclusive of sense or meaning. Its function is symbolic to the extent that its absence determines the automatism of repetition. The letter constitutes the unconscious to the extent that it is organized as a literal heterogeneous set.

Freud's first allusion to the letter and its function is found in his correspondence with Wilhelm Fliess on December 6, 1896 (1950a), where he describes a system of inscribing perceptions, in which the process of repression can be conceptualized as the erasure of an inscription. In the analysis of the Wolfman, Freud (1918b) returns to the letter and its workings. In 1927, in his article on fetishism (1927e), he shows how a patient's erotic life remains attached to a permutation of letters.

However Freud never really formulated a theory of the letter. Jacques Lacan in 1954–1957 (1966) provided a theoretical elaboration of the functioning of the letter to the extent that it—and it alone—constitutes the topography of the unconscious.

Several additional aspects of how the letter functions need to be distinguished: its situation within the articulation of the two essential tropes that govern language, metaphor, and metonymy (Roman Jakobson), and the function it plays in the dialectic of desire and the automatism of repetition. To explain these functions a few linguistic concepts are necessary.

Returning to the Saussurian algorithm, Lacan emphasized the impermeable nature of the bar that separates signifier and signified. Contrary to what is suggested by the illustration of the algorithm between the sound "tree" and its iconic representation, the unconscious does not acknowledge any univocal correspondence between a signifier and a signified, because the signifier only functions through its difference with other elements in the verbal chain. Because of these three factors access to meaning can only occur through metaphor or metonymy. Thus Freud discovered the processes of condensation (*Verdichtung*) and displacement (*Verschiebung*) in dreams. These two

operations take place at the cost of eliding the signifier upon which they were originally based. This first obliterated signifier is automatically repressed as part of the natural operation of the production of meaning. By extension, we recognize in this the model of symptom formation as a fact associated with language. Within the differential coupling of signifiers as they occur in a language this first signifier, the indifferent point of departure for metaphor or metonymy, can be conceptualized as precipitated in the materiality of a letter that represents it in the chain of signifiers. This letter also prefigures the trace of the lost object and the lack that causes desire, for in metonymy the trace of the loss is transferred to the object of desire. This led Lacan to designate the object-cause of desire by the letter *a*. The letter thus has a symbolic function that overdetermines the unalterable principle of the automatism of repetition to the extent that a letter will always be missing, the very letter that represents the lost object.

Moreover, the impossibility of grasping the letter in its signification, its resistance to meaning, because it lies outside the signified, shows that in its essence the letter is real: It forms a hole in unconscious knowledge. Exploration of this hole in meaning using the real of the letter remains the nub of the unconscious in the experience of analysis.

JEAN-PIERRE HILTENBRAND

See also: Real, the (Lacan); Signifier; Symptom/sinthome.

### **Bibliography**

Freud, Sigmund. (1918b). From the history of an infantile neurosis. *SE*, 17: 1–122.

———. (1927e). Fetishism. *SE*, 21: 147–157.

———. (1950a). Extracts from the Fliess papers, *SE*, 1: 173–280.

Lacan, Jacques. (1966) *Écrits*. Paris: Le Seuil.

---

## **LEUBA, JOHN (1884–1952)**

A doctor in the natural sciences and medicine, a psychoanalyst, and a member of the Société psychanalytique de Paris (SPP; Paris Psychoanalytical Society) from 1932, John Leuba was born in Corcelles, Switzerland, near Neuchâtel, in 1884; he died there on May 11, 1952.

Leuba's father, a pharmacist in Corcelles, inspired his interest in the natural sciences. At the end of his studies he turned his focus to geology. In Neuchâtel he became assistant to Professor Schardt, whose daughter he married several years later.

After an illness of unknown origin, Leuba earned his medical degree in Geneva. During the First World War he was a volunteer in hospitals in France. In 1925 he went to Paris and worked for the publishing house Armand Colin, which published his *Introduction à la géologie* (Introduction to geology) in 1925.

During the period from 1928 to 1930, he became a doctor in the faculty of medicine in Paris. He went into analysis with Rudolph Löwenstein and worked under the supervision of René Laforgue. He was secretary of the Société psychanalytique de Paris from 1934, and served as its president from 1946 to 1948.

Leuba was an artist with a genuine talent for drawing, and he excelled in his case descriptions. Not much inclined toward theory, he devoted his best efforts to clinical observation. His articles were published in the *Revue française de psychanalyse*; “Analyse rapide d'un névrose d'angoisse à base de complexe de castration” (Summary analysis of an anxiety neurosis based on the castration complex) and “La pensée magique chez le névrosé” (Magical thinking in neurotics) exemplify his qualities as a clinician. In 1936, at the Ninth Conference of French-Speaking Psychoanalysts in Nyon, he delivered a paper entitled “La famille névrotique et les névroses familiales” (The neurotic family and family neuroses), in which he asked the question: “Are there such things as Catholic neuroses, Protestant neuroses, and Jewish neuroses?”

He was part of the “Club des piqués” gathered around Laforgue in the Midi. In a poem dedicated to Délia Laforgue, he expressed his enthusiasm for wine, wild times, and pleasures shared among true friends, “the truest of the true.”

The second volume of the *Revue française de psychanalyse* (1939) contained his article, “Batrachomyomachie: Document pour la défense et illustration du thème oedipien” (Batrachomyomachia: Document for the defense and illustration of the oedipal theme), but because of the war this issue was not released and the article appeared only in 1948. This strange article begins as follows: “For as long as I can remember, I have always felt a singular tenderness toward toads.” Childhood memories and fantasies are blended

together into a narrative without any psychoanalytic analysis.

He continued his clinical practice in Paris during the war, serving at the same time as a volunteer doctor in the emergency ward at the municipal building of the 16th arrondissement. In 1945 he accused Laforgue of having collaborated with the Nazis. His denunciation resulted in a trial, but the case was dismissed for lack of proof.

Francis Pasche, during the Occupation, and, later, Jean Favreau and Pierre Luquet did their training analyses with Leuba. At Leuba's funeral, Charles Odier described him as having lived in the physical and the human, and not in the metaphysical.

JEAN-PIERRE BOURGERON

*See also:* Belgium; France; Magical thought; *Revue française de psychanalyse*; Société psychanalytique de Paris et Institut de psychanalyse de Paris.

### **Bibliography**

- Leuba, John. (1934). Compte rendu VIII Conférence des psychanalystes de langue française. *Revue française de psychanalyse*, 7, 116–136.
- . (1936). La famille névrotique et les névroses familiales. *Revue française de psychanalyse*, 9 (3), 360–419.
- . (1939). Batrachomyomachie: Document pour la défense et illustration du thème oedipien. *Revue française de psychanalyse*, 12 (1), 55–79.

## **LEVI BIANCHINI, MARCO (1875–1961)**

Marco Levi Bianchini, an Italian psychiatrist, was born in Rovigo in 1875 and died in Nocera Inferiore in 1961. He came from a Jewish family and studied medicine in Padua. After serving as a teaching assistant at the psychiatric hospital of Nocera Inferiore (Salerno), he became a professor of psychiatry in Naples. In 1924 he became the head of the psychiatric hospital in Teramo. After publishing *L'isterismo dalle antiche alle moderne dottrine* (Hysteria from antiquity to modern doctrine), he began corresponding with Sigmund Freud and, in 1915, published a translation of "Five Lectures on Psychoanalysis" (*Cinque conferenze sulla psicoanalisi*), soon followed by *Il sognor* (The dream; 1919) and, in 1921, *Tre saggi sulla teoria sessuale* (*Three essays on the theory of sexuality*). In 1920 he founded

the Biblioteca psicoanalitica internazionale, which published works by Freud and other pioneers of psychoanalysis for the first time in Italy.

Following his encounter with Edoardo Weiss in 1921, Levi Bianchini worked to make the journal *Archivio generale di neurologia e psichiatria*, which had been recently established, the leading Italian publication on Freudian psychoanalysis. For Weiss, the collaboration with Levi Bianchini to promote psychoanalysis was more of a hindrance than a help. Because Levi Bianchini was hampered by positivist psychiatric prejudices and incomplete knowledge of psychoanalysis, his enthusiasm for Freud's ideas did little to ensure their welcome reception in Italy.

After becoming a member of the Vienna Psychoanalytic Society in 1922, Levi Bianchini surprised Weiss by deciding to found, in 1925 in Teramo, the Società psicoanalitica italiana (Italian Psychoanalytic Society), whose members were mostly local psychiatrists without any psychoanalytic training. Weiss appealed to Freud, who advised him to accept this as a fait accompli. Freud commented, "It often happens that form precedes content," and he hoped that Weiss, through his abilities and efforts, would provide the content. In 1932, when Weiss reestablished the Società psicoanalitica italiana in Rome, Levi Bianchini became honorary president for life, though rarely attending the society's meetings.

Racial laws forced Levi Bianchini to resign as head of the hospital in Nocera. After 1945 he continued to work privately as a psychiatrist and participated in meetings of the Società psicoanalitica italiana less and less. In 1956 Italian psychoanalysts asked him to preside over the hundredth anniversary of Freud's birth. In 1995 *Biolibido*, a collection of his psychoanalytic writings, was published. Although the essays are dated and have little interest for contemporary psychoanalysts, Levi Bianchini nonetheless deserves recognition as one of the first translators of Freud in Italy.

ANNA MARIA ACCERBONI

*See also:* Italy; *Rivista di psicoanalisi*.

### **Bibliography**

- David, Michel. (1966). *La psicoanalisi nella cultura italiana*. Turin, Italy: Boringhieri.
- Levi Bianchini, Marco. (1995). *Biolibido: Antologia di scritti psicoanalitici (1920–1936)*. Chieti, Italy: Métis.

Musatti, Cesare. (1961). Marco Levi Bianchini. *Rivista di psicoanalisi*, 7, 1.

Quarchioni, Marco. (1988). Marco Levi Bianchini e la “Biblioteca psicoanalitica italiana.” *Notizie dalla Delfico*, 1, 3–22.

---

## LIBERMAN, DAVID (1920–1983)

David Liberman, an Argentinean psychiatrist and psychoanalyst, was born in Buenos Aires on October 2, 1920, and died there on October 30, 1983.

He was the second of three boys in a middle-class Jewish family. His mother died very young. Two men were to mark his life: his father Sam, a jazz musician, and the psychoanalyst Enrique Pichon-Rivière, his mentor. Liberman followed in his father's footsteps and paid for his medical studies with his earnings as a jazz musician. He married young and had two children: Diana, who became a psychoanalyst, and Alex, who turned to journalism.

Liberman took an interest in Freud when still a medical student, having heard of him from his childhood friend, Léon Grinberg. Later he worked in the psychiatric department run by Enrique Pichon-Rivière. His doctoral thesis, published in 1947, already indicated his leaning toward psychoanalysis: *Semiología Psicosomática* (Psychosomatic signs and symptoms).

Liberman was a brilliant psychoanalyst, gifted with extraordinary intuition. He showed remarkable clinical know-how with his patients and impressed the Argentine psychoanalytic milieu with his ability to tap into the unconscious of his colleagues. Although he was influenced from various different quarters, Pichon-Rivière made a major impression on him.

Liberman distinguished himself mainly by the way he integrated into psychoanalysis an approach derived from linguistics and the theory of communication. His preoccupation with external reality, particularly in analyst-patient communication when seen through the prism of what he called their “styles,” made up Liberman's own extremely original style. Throughout his life he conducted research into the theory of communication in conjunction with Argentine, French, and Soviet linguists. He remained totally independent of trends.

His output consists of more than sixty studies published between 1947 and 1984. In 1962 he published

his first book on the theory of communication, *La Comunicación en la terapia psicoanalítica* (Communication in Psychoanalytic Therapy). He developed his contributions on styles of interpretation and patient-analyst communication in a fundamental work entitled *Lingüística, Interacción comunicativa y Proceso psicoanalítico* (Linguistics, communicative interaction, and psychoanalytic process), published in three volumes in 1971–1972, followed by, among other articles and joint efforts, *Psicoanálisis y Semiótica* (Psychoanalysis and semiotics; 1975) and *Comunicación y Psicoanálisis* (Communication and psychoanalysis; 1976). His last book, *Semiotica y Psicoanálisis de niños* (Semiotics and child psychoanalysis), written in collaboration with some of his disciples, was published after his death, in 1984.

GILDA SABSAY FOKS

*Work discussed: Lingüística, Interacción comunicativa y Proceso psicoanalítico*

*See also:* Argentina; Federación psicoanalítica de América latina.

### Bibliography

Liberman, David. (1962). *La comunicación en terapia psicoanalítica*. Buenos Aires: Eudeba.

———. (1971–72). *Lingüística, interacción comunicativa y proceso psicoanalítico*. Buenos Aires: Nueva Visión.

———. (1975). *Psicoanálisis y semiótica*. Buenos Aires: Paidós.

———. (1976). *Comunicación y psicoanálisis*. Buenos Aires: Alex.

---

## LIBIDINAL COEXCITATION. *See* Reciprocal paths of influence

---

## LIBIDINAL DEVELOPMENT

A major contribution of psychoanalysis to human understanding is its explanation of neurotic mental disorders in terms of fixation or regression of the libido. *Libido*, a Latin term meaning desire, want, amorous desire, is defined as the instinctual sexual energy underlying all mental activity. Psychoanalysis

saw libidinal development as spanning the whole psychosexual evolution of the individual from birth to adulthood, as reconstructed in psychoanalytic treatment. Such treatment takes into account the early phases in the organization of the libido, the psychic structure that results from the individual's Oedipus complex and the modes of its resolution, the adolescent phase, and the resulting genital organization of the adult and choice of object.

Development, which involves stages, phases, and periods of organization, is a transformation from an original state to a state of completion. From a libidinal point of view, this final state is the state of adult sexuality, which Freud considered to be the end point of the infantile sexuality present in different forms in different phases. At the time, this idea of infantile sexuality provoked a strong reaction in the scientific world, which rejected psychoanalysis as being "pansexual." The affirmation of infantile sexuality may well have scandalized the world far more than other important ideas in psychoanalysis, such as the notion of dreams having a meaning and the existence of an unconscious psychic life.

The notion of the libido appears in Freud's writings as early as his letters to Wilhelm Fliess, but Freud used it in the general sense used by late-nineteenth-century authors who began to take an interest in human sexuality, particularly Albert Moll and Richard Krafft-Ebbing, who studied sexual psychopathies. In 1905, however, Freud defined the libido in *Three essays on the theory of sexuality* in reference to the theory of instincts, thus founding the psychoanalytic conception of psychic functioning. These essays invite us to follow the evolution of the sexual instinct in the individual in accordance with specific phases of psychic organization, as well as their consequences in terms of people's psychic reality and the nature and characteristics of the relations people establish with others. Psychoanalysis thus concentrates more on the dynamic character of sexuality and its role in the unconscious, rather than seeking to describe it as a succession of temporal stages.

The sexual instinct during pregenital phases is autoerotic and is linked to particular zones (the oral cavity, anus), the location of this erotic pleasure depending on the degree of maturity (sucking in infancy, the pleasure of stool retention and expulsion when acquiring sphincter control). Freud made direct observations, which he then described, such as the pleasure of the baby feeding at its mother's breast or the adolescent

masturbating. In these pregenital stages the sexual instinct consists of component instincts such as the sadistic instinct, the instinct for knowledge, the instinct for mastery, these nonerotic components being directed toward the object. (These component instincts often appear as pairs of opposites, for example, the instinct to see and be seen.) The great variety and diversity of these component instincts led Freud to declare that children were polymorphously perverse, each of these instincts being capable of continuing later in life in certain adult perversions (voyeurism and sadism, for instance). But this predisposition could also "be regarded as the source of a number of our virtues, in so far as through reaction-formation it stimulates their development" (Freud, 1905d, p. 239).

In the course of a later phase situated between the ages of three and six, the component instincts are unified and organized under the primacy of the genital zone. Then the individual discovers the anatomical difference between the sexes (for Freud, this was limited in both sexes to the presence or absence of a penis). This discovery opens the way to, and organizes, the phallic phase from the fourth year onward. The reaction to this discovery is very different in boys and girls: boys now find themselves confronted with the oedipal problem and castration anxiety. The early dual relationship of mother and son is then followed by a triangular relationship involving both parents, a situation rich in conflict. Freud called this the Oedipus complex, the resolution of which leads to a psychic structure that includes the superego, through the internalization of parental prohibitions. This "childhood neurosis" constitutes the original nucleus of all adult neuroses.

This first period of infantile sexuality is followed by a latency period that is quiet in comparison to the efflorescence of the previous period. Sexual development now comes to a halt or regresses. Previously persistent tendencies succumb to moral repression and moral reactions; shame and disgust make their appearance. During adolescence the thrust of puberty brings the oedipal conflicts to the fore all over again, and their resolution results in the adult genital organization and a definitive object choice.

In the course of development the child takes his or her own body as a love object; then the libido turns toward the parents before finally choosing some outsider as an object. This path temporarily leads to a homosexual object choice and "at the age of puberty boys and girls show clear signs, even in normal cases,



of the existence of an affection for people of their own sex” (Freud, 1905d, p. 60), before choosing a heterosexual object. The vicissitudes of this development create fixation points that become way stations in the regressive psychopathological conditions of the adult. Many authors after Freud set about describing them, particularly Karl Abraham.

Although libidinal development includes these infantile and adult oral, anal, and genital phases, it is not just a succession of temporal phases that accumulate, overlap each other, and develop concomitantly. Structuring and organization of the agencies which takes place under the effect of “après-coup.” This notion of stimulus enables us to account for the reorganizations introduced later in particular circumstances. A repressed memory, for example, can be transformed “après-coup” into a traumatism. The progressive differentiation of intrapsychic agencies—the ego from the id in early childhood, and the superego as the heir to the Oedipus complex—is one of the achievements of libidinal development and ensures psychic functioning regulated by the pleasure principle and the reality principle.

Melanie Klein offered a profound revision of the Freudian theory of libidinal development by proposing a duality in the life and death instincts. She stressed the precocious nature of the superego and the Oedipus complex. She claimed that the triangular structure of the Oedipus complex could be observed well before the beginning of the genital phase and before the child considered *total objects*, *partial objects* (breast, feces, penis) being the only objects having a role to play at this time. She also stressed the precocious modes of object relations, referring to them not as *phases* in libidinal organization, but as *positions*: the paranoid-schizoid position and the depressive position.

MICHÈLE POLLAK CORNILLOT

*See also:* Activity/passivity; Adolescence; Anality; Antilibidinal ego/internal saboteur; Autoeroticism; Bisexuality; Breast, good/bad object; Castration complex; Choice of neurosis; “Claims of Psychoanalysis To Scientific Interest”; Developmental disorders; Eroticism, oral; Fixation; Genital love; Genital stage; Introjection; Latency period; Libidinal development; Libidinal stage; Libido; Masculinity/femininity; Narcissism; Object; Ontogenesis; Orality; Oral-sadistic stage; Oral stage; Preenatal; Psychosexual development; Quasi-independence/transitional stage;

Sexual drive; Sexuality; Stage (or phase); *Three Essays on the Theory of Sexuality*.

### **Bibliography**

- Abraham, Karl. (1927). A short history of the development of the libido. In *Selected papers of Karl Abraham* (Douglas Bryan and Alix Strachey, Trans.). London: Hogarth Press and the Institute of Psycho-Analysis. (Original work published 1924.)
- Brusset, Bernard. (1992). *Le développement libidinal*. Paris: Presses Universitaires de France.
- Freud, Sigmund. (1905d). Three essays on the theory of sexuality. *SE*, 7: 123–243.
- Green, André. (1990). *Le complexe de castration*. Paris: Presses Universitaires de France.
- Klein, Melanie. (1932). *The psycho-analysis of children* (Alix Strachey, Trans.). London: Hogarth.
- Perron, Roger, and Perron-Borelli, Michèle. (1994). *Le complexe d'Edipe*. Paris: Presses Universitaires de France.

### **Further Reading**

- Peller, Lili E. (1965). Comments on libidinal organizations and child development. *Journal of the American Psychoanalytic Association*, 13, 732–7.

---

**LIBIDINAL EGO.** *See* Antilibidinal ego/internal saboteur

---

### **LIBIDINAL STAGE**

Each libidinal stage, or developmental phase of childhood, is characterized by a specific organization of the libido linked to a dominant, organizing erotogenic zone where excitation is centered and around which fantasies are constructed. The notion of stages does not imply any strictly chronological sequence: these are “phases” or “levels of organization” that may well overlap or coincide.

Freud’s earliest theorizations of the idea of stages already implied that each stage represented a specific organizational mode. From the outset, when he was influenced by Wilhelm Fliess’s theory of periodicity, Freud had correlated mental organization and the “choice of neurosis” with a succession of phases or periods in the child’s development. Later, he linked these different developmental phases to the dominance

or the abandonment of one or other of the erotogenic zones (mouth, anus, penis, clitoris). He also saw the process of repression as closely associated with the relinquishment of one such zone in favor of another.

The first edition of the *Three Essays on the Theory of Sexuality* (1905d) made mention only of the oral and anal erotogenic zones, as contrasted with the sexuality of puberty and adulthood, which was dominated by the genital. Subsequently Freud would flesh out the theory of the stages of the libido when, between 1913 and 1923, he introduced the oral, anal, and phallic pregenital stages which preceded the establishment of the genital stage.

In seeking to define the organizational modes of pregenital sexuality, Freud viewed matters from two standpoints. The first of these considered the successive phases of psychic organization in terms of the prevailing erotogenic zone: The one, in each case, upon which excitation focused and around which fantasies were constructed (Perron-Borelli, 1997). The second perspective stressed the libidinally-cathexed object and the temporal sequence in accordance with which the subject passed in turn through the various phases of autoerotism, narcissism, and homosexual or heterosexual object-choice. Each libidinal stage was characterized by a particular type of object-relationship, so that incorporation typified the oral stage while retention-expulsion was specific to anal eroticism (Abraham, 1924). This approach showed how the object, just as much as the erotogenic zone, played an organizing role.

The idea of libidinal stages (the terms *phase* and *level of organization* are more widely used today) has on occasion encouraged simplistic interpretations that over-emphasize the supposed dates of onset and precise order of the stages. It is impossible to overstate the fact that for psychoanalysis no strict sequencing is required: "The temporal ordering of these stages certainly implies a hypothesized priority of one phase with respect to the next, but the hypothesis in question is inferred from the analysis of adults.... In other words, all the stages survive as strata embedded in instinctual impulses and unconscious fantasies" (Perron and Perron-Borelli, 1994).

Freud himself wrote that the different phases of libidinal development could "overlap one another [or] be present alongside one another" (1940a, p. 155). In fact, the chief benefit of the theory of stages is that it helps us to construct a temporal framework in which to locate those effects of anticipation and deferred

action, which in turn allow us to understand the mechanism of repression.

JEAN-FRANÇOIS RABAIN

See also: Stage (or phase).

### **Bibliography**

- Abraham, Karl. (1927). A short study of the development of the libido, viewed in the light of mental disorders. In *Selected papers on psycho-analysis*. London: Hogarth. (Original work published 1924)
- Freud, Sigmund. (1905d). Three essays on the theory of sexuality. *SE*, 7: 123–243.
- . (1940a). An outline of psycho-analysis. *SE*, 23: 139–207.
- Perron, Roger, and Perron-Borelli, Michèle. (1994). *Le complexe d'Oedipe*. Paris: Presses Universitaires de France.
- Perron-Borelli, Michèle (1997). *Dynamique du fantasme*. Paris: Presses Universitaires de France.

---

## **LIBIDO**

Freud defined the term *libido* psychoanalytically in an addition, written in 1915, to *Three Essays on the Theory of Sexuality* (1905d): "We have defined the concept of libido as a quantitatively variable force which could serve as a measure of processes and transformations occurring in the field of sexual excitation" (p. 217).

In *Group Psychology and the Analysis of the Ego* (1921c), he further developed this concept: "Libido is an expression taken from the theory of the emotions. We call by that name the energy, regarded as a quantitative magnitude (though not at present actually measurable), of those instincts which have to do with all that may be comprised under the word 'love'" (p. 90).

The "libido theory" is present throughout Freud's works, beginning with the first appearance, in Manuscript E of the Fliess papers (1950a [1895]), of the notion of "psychical libido," as synonym of "psychical affect" (p. 192, 193). This draft dates from June 1894—that is to say, before the appearance of Albert Moll's book, *Untersuchung über die Libido sexualis*, from which Freud claimed to have borrowed it. The theory of the libido was constantly revised and remodeled from three main angles: the developmental, the metapsychological (then associated with the theory of

the instincts and the dynamic and economic points of view), and the psychopathological.

In the *Three Essays on the Theory of Sexuality* (1905d), Freud based the psychoanalytic notion of libido on infantile sexuality, explaining how it drew support from the major vital functions (anaclisis): “The fact of the existence of sexual needs in human beings and animals is expressed in biology by the assumption of a ‘sexual instinct,’ on the analogy of the instinct of nutrition, that is of hunger. Everyday language possesses no counterpart to the word ‘hunger,’ but science makes use of the word ‘libido’ for that purpose” (p. 135). Starting with the autoeroticism of the erogenous zones, and building on the work of Karl Abraham, he developed the idea of a series of developmental phases leading from the “pregenital libidinal organization,” through the oral, anal-sadistic, and phallic stages (1923e), to the genital stage.

At the same time, Freud contrasted libido, in his earliest versions of the instinct theory, as the energy of the sexual drives, with the energy of the “ego-instincts.” This was a subject he returned to often, so as to differentiate his ideas from the ideas of Carl G. Jung, as first outlined in Jung’s *Transformation and Symbolism of the Libido* (1913). Jung saw libido as close to the *élan vital* of Henri Bergson. Freud explained his position in a letter to Édouard Claparède of December 25, 1920: “I’ve repeated and would like to say as clearly as possible that I want to establish, for transference neuroses, the distinction between sexual drives (*Sexualtriebe*) and ego drives (*Ichtriebe*); and the libido signifies for me only the energy of the former, the sexual drives. It is Jung, not I, who conceives of the libido as the animating force of all psychic activities, consequently contesting the sexual nature of the libido. Your affirmation applies, therefore, neither to me nor to Jung totally; it rather is based on a *mélange* of the two. From me you borrow the sexual nature of the libido, from Jung its universal significance, from which is born pansexualism, something that exists only in the imagination of certain critics, so fertile when it comes to manipulating things.”

“On Narcissism: An Introduction” (1914c) marked a major theoretical turning point in Freud’s work. Ego-libido, now also called “narcissistic libido,” was viewed as a primal libidinal cathexis, a part of which was detached, and directed onto objects: “Thus we form the idea of there being an original libidinal cathexis of the ego, from which some is later given off to objects, but

which fundamentally persists and is related to the object-cathexis much as the body of an amoeba is related to the pseudopodia which it puts out” (p. 75). But if the ego was presented in this context as a reservoir of libido, with the introduction of the second topography (or structural theory), Freud revised this view: “Now that we have distinguished between the ego and the id, we must recognize the id as the great reservoir of libido. . . . The libido which flows into the ego owing to the identifications described above brings about its ‘secondary narcissism’” (1923b, p. 30n). This contradiction would be the cause of much post-Freudian discussion and theorizing. As for its object-relationships, “The libido attaches itself to the satisfaction of the great vital needs, and chooses as its first objects the people who have a share in that process” (1921c, p. 103).

Nevertheless, from *Beyond the Pleasure Principle* (1920g) on, the introduction of the death instinct announced a radical new dualism: “In this way the libido of our sexual instincts would coincide with the Eros of the poets and philosophers which holds all living things together” (p. 50), while “The opposition between the ego-instincts and the sexual instincts was transformed into one between the ego-instincts and the object-instincts, both of a libidinal nature. But in its place a fresh opposition appeared between the libidinal (ego-and-object-) instincts and others, which must be presumed to be present in the ego and which may perhaps actually be observed in the destructive instincts” (p. 61, note added 1921).

Libidinal cathexes enter the framework of Freud’s metapsychological descriptions by way of their dynamism: The libido is susceptible in the course of development to “fixations” at particular stages; even if such a fixation is bypassed later and subjected to repression, it can re-emerge when some mental obstacle, such as the fear of castration, happens to obstruct progress and precipitates a “regression.” Likewise, transformations of libidinal cathexes are possible, “in such a way that they cannot come up against frustration from the external world. In this, sublimation of the instincts lends its assistance” (1930a [1929], p. 79).

As for the “economic point of view,” it was present from Freud’s earliest descriptions of the libido as an “energy,” or a “force” (1897), right up until his very last writings, when he evokes “the total available energy of Eros, which henceforward we shall speak of as ‘libido’” (1940a [1938], p. 149). Freud studied both the process of the libido’s production and the manner of its

displacements, even invoking a certain “adhesiveness of the libido” to explain certain difficulties encountered in psychoanalytic treatments, he added that “One meets with the opposite type of person, too, in whom the libido seems particularly mobile; it enters readily upon the new cathexes suggested by analysis, abandoning its former ones in exchange for them” (1937c, p. 241).

Let us now turn to the applications of the notion of the libido in the domain of psychopathology. In a letter to Karl Abraham (1965a), Freud pointed the way: “The characteristic traits of neuropsychoses and psychoses are connected with the destiny of the libido—where it is localized relative to the ego and the object, the varieties of repression concerning this libido, as well as how this repression evolves chronologically.” It will be recalled that Freud deemed regression to pregenital stages the key to obsessional neurosis and depression. Later, “the effect of seduction, which is responsible for a premature fixation of the libido” (1922b, p. 231) was described by him as one of the causative factors of homosexuality. In an article on psychoanalysis for the *Encyclopaedia Britannica*, he wrote: “The infantile fixations of the libido are what determine the form of any later neurosis. Thus the neuroses are to be regarded as inhibitions in the development of the libido” (1926f, p. 268); and in *An Outline of Psycho-Analysis* he pointed out “that sadism is an instinctual fusion of purely libidinal and purely destructive urges, a fusion which thenceforward persists uninterruptedly” (1940a [1938], p. 154). In this connection we should mention the theory of anxiety. In *The Interpretation of Dreams* (1900a), Freud described anxiety as “a libidinal impulse which has its origin in the unconscious and is inhibited by the preconscious” (pp. 337–338); later he attributed it to a transformation of the libido under the pressure of repression, and finally offered his definitive revision of the theory of anxiety in *Inhibitions, Symptoms and Anxiety* (1926d [1925]).

In his paper on “Libidinal Types” (1931a), Freud developed a new psychoanalytical typology: “According . . . as the libido is predominantly allocated to the provinces of the mental apparatus, we can distinguish three main libidinal types. To give names to these types is not particularly easy; following the lines of our depth-psychology, I should like to call them the *erotic*, the *narcissistic* and the *obsessional* types. . . . These pure types will hardly escape the suspicion of having been deduced from the theory of the libido. But we feel ourselves on the firm ground of experience

when we turn to the mixed types, which are to be observed so much more frequently than the unmixed ones. These new types—the *erotic-obsessional*, the *erotic-narcissistic* and the *narcissistic-obsessional*—seem in fact to afford a good classification of the individual psychical structures which we have come to know through analysis. . . . We thus realize that the phenomenon of types arises precisely from the fact that, of the three main ways of employing the libido in the economy of the mind, one or two have been favoured at the expense of the others” (pp. 217–219).

Karl Abraham, Sándor Ferenczi, and the first psychoanalysts followed or developed the views of Freud, but the same cannot be said always for later generations. Critics focused on the “narcissistic libido,” rather than on those formulations of Freud’s that appeal to biology and pharmacology to account for sexual excitation—as when he wrote, for example, of the “sexual toxin which we should have to recognize as the vehicle of all the stimulant effects of the libido” (1916–17a [1915–17], pp. 388–389). While Paul Federn or Edoardo Weiss suggested calling the energy of aggressive drives “destrudo” or “mortido,” to distinguish it from the libido, some, such as Rudolph M. Lowenstein, emphasized the contradiction arising from the very notion of “narcissistic libido,” for “there cannot be two kinds of psychic energy, characterized by the simple fact that one is directed toward the object and the other towards the self” (1965). James Strachey and Heinz Hartmann have also discussed confusions arising from Freud’s successive formulations on the subject of the narcissistic libido and the role of the ego: Did these concern an “ego” or a “Self,” primary narcissism seeming to suggest “the whole person” rather than that of the Freudian “ego”? Starting in 1941, Ronald Fairbairn developed the idea that the libido is essentially searching for an object rather than pleasure, and that in psychopathology the emphasis should be on dysfunctions in object-relations. Michael Balint, basing himself on these debates, refuted the notion of “primal narcissism,” and instead worked out a theory of “fundamental lack” (1968). Heinz Kohut, for his part, wrote that “every libido that has a self-idealizing or aggrandizing quality is ‘narcissistic’” (1971).

Jacques Lacan offered a very different approach to the notion of libido at the Bonneval Colloquium (1960), returning to the theme again in *Four Fundamental Concepts in Psychoanalysis* (1964), with his “myth of the

lamella.” He stressed the subject’s search, not for a complement—as the Platonic myth (and Freud in Plato’s wake) would have it—but that part of himself that was lost with the cutting of the umbilical cord, which made of him a mortal and sexed being. The libido here is “the lamella that slides between the organism and its true limit, beyond that of the body”; it is also “something . . . that is related to what the sexed being loses in sexuality, it is like the amoeba in relation to sexed beings, immortal” (1964, p. 197). Lacan defined the libido as “an organ,” or instrument of a drive.

On his part, Freud always tied the libido to an organic substrate; he even compared libido to a toxin: “all our intoxicating liquors and stimulating alkaloids are merely a substitute for the unique, still unattained toxin of the libido that rouses the ecstasy of love” (letter to Karl Abraham of June 7, 1908, in *A Psychoanalytic Dialogue*, p. 40), or “we . . . cannot even decide whether we are to assume two sexual substances, which would then be named ‘male’ and ‘female,’ or whether we could be satisfied with one sexual toxin which we should have to recognize as the vehicle of all the stimulant effects of the libido” (1916–17a, pp. 388–389). In *Three Essays on the Theory of Sexuality* (1905d), he had even proposed a “provisional hypothesis,” rarely mentioned by psychoanalysts, on the “essential factors of sexuality”: “It may be supposed that, as a result of an appropriate stimulation of erotogenic zones . . . some substance that is disseminated generally throughout the organism becomes decomposed and the products of its decomposition give rise to a specific stimulus which acts on the reproductive organs or upon a spinal centre related to them.” He concluded: “I attach no importance to this particular hypothesis and should be ready to abandon it at once in favour of another, provided that its fundamental nature remained unchanged—that is, the emphasis which it lays upon sexual chemistry” (1905d, III, p. 216). Until the end of his life, Freud linked the theory of the libido to the body, as is still evident in the *Outline of Psychoanalysis*: “There can be no question but that the libido has somatic sources, that it streams to the ego from various organs and parts of the body. This is most clearly seen in the case of that portion of the libido, which, from its instinctual aim, is described as sexual excitation. The most prominent of the parts of the body from which this libido arises are known by the name of ‘erotogenic zones,’ though in fact the whole body is an erotogenic zone of this kind” (1940a [1938], p. 151). It is clear how very much further,

since Freud, research on neuro-hormonal links has carried these suggestions, as well as how much, in the future, psychoanalysis will benefit from these new hypotheses.

In Freudian theory, the energy-based conception of the libido was nevertheless based on an electric, or rather hydraulic metaphor, with its flows and dams, countercurrents and anchorage points, lateral pathways through replacement objects or sublimations, its viscosity or stasis: One has only to think of the oft-repeated image of a “great reservoir” of energy. Freud has been reproached for the supposedly “unscientific” nature of such propositions. His own answer to such criticism, in his *Autobiographical Study* (1925d [1924]), was at once prudent and to the point: “I have repeatedly heard it said contemptuously that it is impossible to take a science seriously whose most general concepts are as lacking in precision as those of libido and of instinct in psycho-analysis. . . . In the natural sciences, of which psychology is one, such clear-cut general concepts are superfluous and indeed impossible” (pp. 57–58).

ALAIN DE MIJOLLA

*See also:* Aggressiveness; Anality; Cathectic energy; Cathexis; Decathexis; Desexualization; Destruo; Economic point of view; Ego-libido/object-libido; Eroticism, anal; Eroticism, oral; Eros; Erotogenicity; Fixation; Genital love; Libidinal development; Orality; Psychic energy; Regression; Sexuality; Signal anxiety; Stage (or phase); Sublimation; *Three Essays on the Theory of Sexuality*.

### **Bibliography**

- Freud, Sigmund, and Abraham, Karl. (1965). *A psychoanalytic dialogue, the letters of Sigmund Freud and Karl Abraham, 1907–1926* (Hilda C. Abraham and Ernst L. Freud, Eds.) (Bernard Marsh and Hilda C. Abraham, Trans.). New York: Basic Books.
- Hartmann, Heinz. (1956). The ego concept in Freud’s work. *International Journal of Psychoanalysis*.
- Lacan, Jacques. (1964). From love to the libido. In *The four fundamental concepts in psychoanalysis* (Alan Sheridan, Trans.). New York: Norton, 1978.
- Lowenstein, Rudolph M. (1965). Observational data and theory in psychoanalysis. In M. Schur (Ed.), *Drives, affects, behaviour. Essays in memory of Marie Bonaparte*. Vol. 2. New York: International Universities Press.

### Further Reading

Lichtenberg, Joseph D. (1994). How libido theory shaped technique (1911–1915). *Journal of the American Psychoanalytic Association*, 42, 727–740.

## LIE

A lie, the dissimulation or willful deformation of the contents of a thought that the subject deems to be true, can be practiced only either vis-à-vis another person or by means of a split in the subject—in which case the subject lies “to him- or herself.” A lie implies the intent to deceive and supports self-interest. The psychoanalytic approach to lying introduces the dimension of the unconscious.

The earliest psychoanalytic consideration of lies is found in Freud’s “Project for a Scientific Psychology” (1950c [1895]), where he envisioned lies solely in the context of the psychiatric definition of hysteria as a form of simulation, although he rejected this perspective. While he acknowledged the existence of a tendency toward simulation and lying in hysterics, he attributed it to the fact that the patient “wishes to be ill,” (p. 249), itself the result of patients’ need to convince themselves and those around them of the reality of their suffering.

In “Project for a Scientific Psychology,” the *πρωτου πσευδος* (*proton-pseudos*) is usually translated as “first hysterical lie” although it in fact involves an error or mistaken connection rather than an intentional dissimulation or distortion. The well-known example of Emma shows that the “error” had to do with the fact that she related her attack of agoraphobia to the shop-assistants’ ridicule of her clothes when she was thirteen, whereas the determining event, although its felt effects were deferred, was the memory-trace of a shopkeeper’s pedophilic assault on her when she was a child. The mistaken connection resulted from the repression of a childhood memory that was not available to her at the time of the scene when she was thirteen (“Hysterics suffer mainly from reminiscences” [p. 7]).

In “Two Lies Told by Children” (1913g) Freud emphasized that lies between parents and children are “natural.” In “On the Origin of the ‘Influencing Machine’ in Schizophrenia” (1919/1991), Viktor Tausk wrote: “children learn to lie from parents and

upbringers, who by misrepresentations and unkept promises make the child obey and teach him to disguise his true purposes” (pp. 214–215 n4). The aim of Freud’s article of 1913 was thus to show the existence of unconscious motivations in certain childhood lies that “occur under the influence of excessive feelings of love” (p. 305).

Such motivations do not involve the interests of the ego but instead correspond to an instinctual impulse that cannot be admitted, not because of the strong feelings of shame or unconscious guilt that are attached to it, but because it is unconscious. In the two cases evoked by Freud, incestuous love is behind the error and, secondarily, behind the lie that covers it up. The error itself could have been admitted as a fact, and if it is not acknowledged, this is because of the unconscious content it manifests. The “impossibility” of confession opens the way for reconstitution through deferred action, based on associations produced during the analysis, of the motivations that made the error impossible to confess.

This view leads to seeing the moral fault that the lie represents as a consequence of neurosis. A strictly moral understanding of lies is thus transformed by the psychoanalytical approach into an interrogation of the desire for falsehood. Such a desire, or even need, is incompatible with psychoanalysis, which requires, of analyst and patient alike, not that they tell the truth, but that they seek it.

According to Sándor Ferenczi (1912/1968), the difference between suggestion and psychoanalysis is that the former maintains disguise and repression owing to its basis in the authority of the therapist, where the latter “combats the ‘vital lie’ wherever it is found ... its final goal [being] to let light penetrate into human consciousness as far as the most hidden wellsprings of motivations for actions.” Ferenczi, too, stigmatized the pedagogy of his time, which imposed upon children the repression of emotions and ideas. In “Psychanalyse et pédagogie” (1908; [Psychoanalysis and education, 1949]), he wrote: “The closest thing to it is lying ... current pedagogy forces the child to lie to himself, to deny what he knows and what he thinks.” Echoed here is Freud’s concern about telling children the truth about sexuality; lying, in this context, appears first and foremost as an adult form of hypocrisy, with children’s lies being a response to it.

Karl Abraham (1925/1927) studied from a psychoanalytic viewpoint the case of a captain of industry, analyzing his compulsion to deceive others as a two-phase process in which he first showed himself to be lovable because he had not been loved by his parents, then did his best to disappoint those whom he had duped in order to take revenge against them. In “Über einen Typus der Pseudoaffektivität (‘Als ob’)” (1934) Helen Deutsch introduced the important notion of the “as if” personality, which is not a utilitarian lie told on a given occasion, but rather protects the “true Self” with a “false Self” (Donald Winnicott). Mythomania can also be situated within this framework of a narcissistic pathology in which lies are addressed both to others and to the self. Moreover, in “The Antisocial Tendency” (1956/1984) Winnicott situated theft associated with lying at the heart of antisocial tendencies in children and adolescents, but also connected this to incontinence and anything that makes a mess. In this context, this would focus on ease and opportunity to the classic moral understanding of an aggressive will to deceive. Lying, like gluttony and theft, originates in frustration.

The psychoanalytic view of lying is thus very broad, because it includes both the dimension of the false, ranging from social adaptation to pathologies of identity, and that of willful deceit, for which explanations relating to frustration or repressed love can be found.

SOPHIE DE MIJOLLA-MELLOR

*See also:* As if personality; Historical truth; Imposter; Memories; Mythomania; “On the Sexual Theories of Children”; Proton-pseudos; Secret; Transitional object; Truth.

### **Bibliography**

- Abraham, Karl. (1927). The influence of oral erotism on character-formation. In *Selected papers of Karl Abraham* (Douglas Bryan and Alix Strachey, Trans., pp. 393–406). London: Hogarth and the Institute of Psycho-Analysis. (Original work published 1925)
- Deutsch, Helene. Über einen Typus der Pseudoaffektivität (‘Als ob’). *Internationale Zeitschrift für Psychoanalyse*, 20.
- Ferenczi, Sándor. (1949). Psychoanalysis and education. *International Journal of Psycho-Analysis*, 30, 220–224. (Original work published 1920)
- . (1968). Suggestion et psychanalyse. In his *Psychanalyse I, Œuvres complètes* (Volume 1: 1908–1912; pp. 233–242). Paris: Payot. (Original work published 1912)
- Freud, Sigmund. (1913g). Two lies told by children. *SE*, 12: 303–309.
- . (1950c [1895]). Project for a scientific psychology. *SE*, 1: 281–387.
- Tausk, Viktor. (1991). On the origin of the “influencing machine” in schizophrenia. In Paul Roazen (Ed.), *Sexuality, War, and Schizophrenia: Collected Psychoanalytic Papers* (Eric Mosbacher et. al., Trans.; pp. 185–220). New Brunswick: Transaction. (Original work published 1919).
- Winnicott, Donald W. (1984). The antisocial tendency. In his *Deprivation and delinquency*. London: Tavistock. (Original work published 1956)

---

## **LIEBEAULT, AMBROISE AUGUSTE (1823–1904)**

Ambroise Auguste Liebeault, a French physician and hypnotist, was born in Favières in Meurthe-et-Moselle on September 16, 1823, and died in Nancy on February 18, 1904.

Born into a large peasant family, he received a Catholic education before studying medicine in Strasbourg, where he took an early interest in magnetism while still an intern. As a physician at Pont-Saint-Vincent near Nancy, he gave free treatment to any patients who agreed to be hypnotized. He then took a two-year sabbatical to write *Du sommeil et des états analogues considérés surtout au point de vue de l'action du moral sur le physique* (Sleep and analogous states considered mainly from the point of view of the influence of moods on physical well-being). The book was published in 1866 but went unnoticed or was considered to be outdated. In what were then the suburbs of Nancy, Liebeault set up a “clinic” (really just a sort of shed next to his house). There he used induced sleep and suggestion under hypnosis to treat working-class patients suffering from a variety of run-of-the-mill “maladies.” He was a marginal physician who had abandoned the standard practices of his profession, but a professor of medicine raised him to the dignified status of a living legend, declaring him to be the founder of a school and an unhailed pioneer. Hippolyte Bernheim was converted to his views and practices in 1882. Liebeault was suddenly famous. The clinic of the “touching old doctor” (Freud, 1925d) became a mandatory stopover for French and European visitors who, like the young Freud, were interested in hypnotism and gravitated around the Nancy school.

In his 1866 book, which was republished at the end of the century, Liebeault claimed allegiance both to the early nineteenth-century French psychological current linked to magnetism (Bertrand and Noizet) and the hypnotic current (Braid and most of all Durand de Gros), which he brought together in his own synthesis. He stressed the influence of the mind on the physical (what we now call psychic and organic). Unlike Bernheim, he refused to equate hypnosis and suggestion and remained attached to the idea of a restless sleep linked to a concentration of attention. Liebeault's therapeutic originality consisted in breaking away from traditional magnetic cures in which patients conducted their own treatment and treated themselves, and promoting positive suggestion from the therapist. According to the testimony of certain visitors, Liebeault's suggestions were sometimes more in the nature of negotiations than categorical orders.

The Freudian text where it is easiest to find traces—paradoxically anonymous because no names are mentioned—of the Nancy school is the popularizing article of 1890, “Psychical (or mental) treatment” (1905b). The main idea expressed in the title, as well as the leitmotif on the magic of words, probably came from Liebeault and Bernheim. More specifically, we find the echo of *Du sommeil et des états analogues*. The comparison of the relationship between the hypnotized person and the hypnotist with a mother feeding a child is in fact a summary of a text by Bertrand that Liebeault cites: “A mother who falls asleep beside her child's cradle, never ceases to watch over him even in her sleep; but she is watchful only for him.” Significantly, Freud then speaks in French of the “*rapport*,” a term used mainly in the vocabulary of animal magnetism to evoke the relationship between the magnetizer and the magnetized person.

JACQUELINE CARROY

See also: Bernheim, Hippolyte; Hypnosis; Suggestion.

### **Bibliography**

- Barrucand, Dominique (1967). *Histoire de l'hypnose en France*. Paris: Presses Universitaires de France.
- Bernheim, Hippolyte. (1903). *Hypnotisme, suggestion, psychothérapie* (2nd ed.). Paris: Fayard.
- Carroy, Jacqueline. (1988). L'école hypnologique de Nancy. I: Liébeault, Beaunis, Liégeois et Delboeuf. II: Bernheim, Charcot et Freud, le Pays lorrain. *Journal de la Société*

*d'archéologie lorraine et du Musée historique lorrain*, 2–3, 108–116, 159–166.

- Cuvelier, André. (1987). *Hypnose et suggestion. De Liébeault à Coué*. Nancy, France: Presses Universitaires de Nancy.
- Delboeuf, Joseph. (1885). *Le sommeil et les rêves*. Paris: Fêlic Alcan.
- . (1993). *Le sommeil et les rêves et autres textes*. Paris: Fayard.
- Freud, Sigmund. (1905b). Psychical (or mental) treatment. *SE*, 7: 283–304.
- . (1925d). An autobiographical study. *SE*, 20: 1–74.

### **LIFE AND WORK OF SIGMUND FREUD, THE**

Ernest Jones's biography of Freud, titled *Sigmund Freud: Life and Work*, appeared between 1953 and 1957. The biography has been translated into all the major European languages. The first volume deals with Freud's childhood, youth, complex academic and personal life, and the gradual discovery of psychoanalysis, including *The interpretation of dreams*. The second volume deals with the years of Freud's maturity: his scientific achievements, his personal and professional life in Vienna during the first two decades of this century, the foundation of the international psychoanalytic movement, his various pupils, and the so-called heretics, such as Alfred Adler and Carl Gustav Jung. The third volume deals with the last period of Freud's life: his later scientific achievements, his troubled personal life and illness, the events that led him and his family to emigrate from Vienna to London to escape Nazi persecution in 1938, and his last months in London until his death. This volume also contains an overview of Freud's work, its links to various other natural and social sciences, and the contribution of psychoanalysis to the understanding of literature and art in general and religion in particular.

In spite of Jones's declarations concerning his objectivity in writing Freud's biography, there were several mitigating factors. One must consider his declared attempt to defend Freud and psychoanalysis from the constant attacks to which they were subjected, the personality of Jones as a biographer of Freud, his complex and often ambivalent relationship toward the founder of psychoanalysis, the cultural and social context in which the biography was conceived and written, and the pressures and control exerted on him and the use



of Freud's material by Anna Freud and other Continental colleagues and friends in America and England. Furthermore, not all the documentation concerning Freud's life and work was available at that time.

In writing the biography Jones was helped by several colleagues and friends. First among them were Siegfried Bernfeld and Suzanne Cassirer-Bernfeld, without whose help many chapters of the first volume would have been impossible. Also helping were Marie Bonaparte, James Strachey, and Kurt Eissler. The biography contains numerous factual errors and has recently been criticized and attacked by many so-called independent scholars, but here one should consider Jones's advanced age and declining health. The work reflects a image of Freud as he was known, loved, and critically appreciated by the generation of analysts and friends who lived and worked with him.

RICCARDO STEINER

*See also:* Anna O., case of; "Autobiographical Study, An"; Freud: *Living and Dying*; *Freud's Self-Analysis*; Fromm, Erich; Gestapo; Jones, Ernest.

#### Source Citation

Jones, Ernest. (1953–1957). *Sigmund Freud: Life and work* (3 vols.). London: Hogarth. (Later published under the title *The life and work of Sigmund Freud*.)

#### Bibliography

Freud, Anna. (1979). Personal memories of Ernest Jones. *International Journal of Psycho-Analysis*, 60, 285–287.

Gay, Peter. (1988). *Freud: A life for our time*. London: Dent.

Mijolla, Alain de. (1998). Freud, biography, his autobiography and his biographers. *Psychoanalysis and History*, 1 (1), 4–27.

Roazen, Paul. (1976). *Freud and his followers*. New York: Alfred A. Knopf.

Steiner, Riccardo. (1993). Introduction. In R. Andrew Paskauskas (Ed.), *The complete correspondence of Sigmund Freud and Ernest Jones, 1908–1939* (pp. 21–49). Cambridge, MA: Harvard University Press.

### **LIFE AND WORKS OF EDGAR ALLEN POE, THE: A PSYCHOANALYTIC INTERPRETATION**

In Sigmund Freud's preface to Marie Bonaparte's book on Poe, he writes, "My friend and student Marie Bonaparte has projected the light of psychoanalysis onto

the life and work of a great writer with pathological tendencies." Two years earlier, another psychoanalyst, René Laforgue, had published *The Defeat of Baudelaire: A Psychoanalytical Study of the Neurosis of Charles Baudelaire* with the same publisher. Poe's mother died of consumption when he was three and Bonaparte's mother died of a pulmonary embolism when she was only two months old. This similarity was to play a role in the enthusiasm Marie Bonaparte put into her analysis of Poe's work. Bonaparte discovered Poe when she was eighteen through the Baudelaire translation, a gift from her father. In 1925 she reread Poe during her analysis with Freud (she was then forty-three years old) and made the following reconstruction: The fear that some of Poe's heroines had once caused her, especially the ghosts, was the fear of the return of her dead mother, whose death she had caused by her birth and who, like an "oedipal ogress," would return to take her revenge.

Bonaparte's work contains four books in two volumes. Book I is devoted to Poe's life and poems. Book II covers the stories devoted to the "mother cycles"—the dead mother-living mother, the landscape-mother, the avowal of impotence, the assassinated mother. Book III covers the "father cycle" stories—the revolt against the father, the conflict with conscience, passivity toward the father. Book IV, "Poe and the Human Soul," compares Baudelaire's genius with that of Poe.

Bonaparte questions recurrent themes found in Poe—ghosts, still waters or seas that grow motionless in the polar ice—in which she detects the fantasy of the return of the mother's body or passive submission to the father. In her comments on "The Purloined Letter," she makes the letter a symbol of the maternal penis. Jacques Lacan made use of her commentary in his seminar on "The Purloined Letter." Marie Bonaparte's book remains a classic of psychobiography.

ANNE-MARIE MAIRESSE

*See also:* Bonaparte, Marie León; Literary and artistic creation; Literature and psychoanalysis; Psychobiography.

#### Source Citation

Bonaparte, Marie. (1949). *The life and works of Edgar Allan Poe, a psycho-analytic interpretation* (John Rodker, Trans.). London: Imago. (Original work published 1933)

## Bibliography

- Bertin, Célia. (1982). *Marie Bonaparte, a life*. New York: Harcourt Brace Jovanovich.
- Bourgeron, Jean-Pierre. (1993). *Marie Bonaparte et la psychanalyse à travers ses lettres à René Laforgue et les images de son temps*. Geneva: Champion-Slatkine.
- Laforgue, René. (1932). *The defeat of Baudelaire: A psychoanalytical study of the neurosis of Charles Baudelaire* (Herbert Agar, Trans.). London: Hogarth Press. (Original work published 1931)

---

## LIFE INSTINCT (EROS)

The *life instinct* or *Eros* was one of the two basic instincts described by Freud in *Beyond the Pleasure Principle* (1920g) when he began to construct his structural theory, in which the life instinct stands opposed to the death instinct. The life instinct subsumed uninhibited sexual instincts, instinctual impulses inhibited in respect of their aim and sublimated, and the instincts of self-preservation.

In contrast to the monism of Jung and Adler, Freud upheld a dualistic theory with respect to the instincts. Up until his discovery of narcissism (1914c), he contrasted the sexual instincts, directed toward outside objects, to the ego-instincts, which included the instincts of individual self-preservation. But then his theory needed modifying in order to respond to the discovery that the ego itself could become the sexual object (1914c). Narcissistic libido thus became a manifestation of the pressure of the sexual instincts, and the former dichotomy between ego-instincts and sexual instincts lost its force. Part of the ego-instincts, namely the self-preservative instincts, were now seen as libidinal in nature, and the main conflict became that between narcissistic and autoerotic instincts, that is, between two forms of the sexual instinct.

With the turning-point of the early 1920s, Freud introduced the hypothesis of a death instinct to account for phenomena of repetition that were independent of the pleasure principle, indeed susceptible of opposing that principle (1920g). His dualistic imperative led him to group both the sexual and the self-preservative instincts under the head of the life instincts, as opposed to the death instincts.

In *The Ego and the Id*, Freud maintained his position on the need to distinguish between the two classes

of instincts: “the task of [the death instinct] is to lead organic life back into the inanimate state; on the other hand . . . Eros, by bringing about a more and more far-reaching combination of the particles into which living substance is dispersed, aims at complicating life and at the same time, of course, at preserving it” (i.e., in the interest of evolution). “Life itself,” Freud added, “would be a conflict and compromise between these two trends” (1923b, pp. 40, 41). Deeming his “fundamental dualistic point of view” inescapable, Freud was “driven to conclude that the death instincts are by their nature mute and that the clamor of life proceeds for the most part from Eros” (p. 46).

Freud held firm to the dualistic view until the end of his life, as witness these lines from his *Outline of Psycho-Analysis*: “After long hesitations and vacillations we have decided to assume the existence of only two basic instincts, *Eros* and *the destructive instinct*.” The aim of Eros was to “establish ever greater unities,” so preserving life; but if “binding together” was thus the task of the life instincts, the aim of the death instincts was “to undo connections and so to destroy things” (1940a [1938], p. 148).

In distinguishing between life and death instincts, Freud sought to introduce a duality within the notion of instinct itself. The outcome was a dual instinct that could be described as two instincts that are so entangled, so melded, that the one can barely have meaning outside of its relationship with the other. This instinctual entanglement arises through the indispensable mediation of the object. Effective instinctual functioning requires that the life instinct serve to bind the death instinct. When the instincts become disentangled, notes Benno Rosenberg, “the subject’s cathexis of the object is so massive that he will have difficulty differentiating himself from it. So intense and unbearable is the excitation that the subject will resort to a splitting of the ego” (1991).

The beneficial contribution of the death instinct, as imbricated with the life instinct, is that it allows a tolerable distance to be maintained between subject and object, thus facilitating the working out of the subject’s wishes.

ISAAC SALEM

*See also:* *Civilization and its Discontents*; Drive/instinct; Eros; German romanticism and psychoanalysis; Love; Marcuse, Herbert; Object, change of/choice of; Primary masochism; Sexuality; Spinoza and psychoanalysis.

### Bibliography

- Freud, Sigmund (1914c). "On narcissism: An introduction." *SE*, 14: 73–102.
- . (1920g). Beyond the pleasure principle. *SE*, 18: 1–64.
- . (1923b). The ego and the id. *SE*, 19: 1–66.
- . (1940a [1938]). An outline of psycho-analysis. *SE*, 23: 139–207.
- Green, André. (2001). *Life narcissism, death narcissism* (Andrew Weller, Trans.). London and New York: Free Association Books. (Original work published 1983)
- Grunberger, Béla. (1979). *Narcissism: Psychoanalytic essays* (Joyce S. Diamanti, Trans.). New York: International Universities Press. (Original work published 1971)
- Rosenberg, Benno. (1991). *Masochisme mortifère et masochisme gardien de la vie*. Paris: Presses Universitaires de France.

## LIFTING OF AMNESIA

The lifting of amnesia involves the return of forgotten memories, and results especially from psychotherapy with hysterics. The notion of the lifting of amnesia, more phenomenological than metapsychological, led to the thought of the lifting of repression. However, it should not be reduced to this. Lifting of amnesia negates a negation, since amnesia abolishes remembrance; lifting it allows the conscious ego to return to normal function, which had been diminished by the amnesia.

This notion surfaced in the first of Freud's works on the theory of neuroses (1894–1896), as well as those on amnesia and mnemic trace written in the same period.

The term *lifting of amnesia* is parallel to "lifting of inhibition" and "lifting of repression." Freud often utilizes the expression of the lifting of the "veil" of amnesia, representing amnesia as something that hides what should have been conscious, a screen that prevents it from being perceived. The semantic and lexicographical field is close to that of the memory-screen (*Deckerinnerung*, "memory-covering" of the "memory cover," *Gedekte Erinnerung*, buried in the amnesia). The images of veil and cover, as well as that of "lifting," emphasized the visual-perception dimension of memory and, for the early Freud, gave concrete expression

to repression, which was rediscovered after the amnesia had been lifted.

Abreaction of post-traumatic affect allows the lifting of amnesia, by "bringing clearly to light the memory of the event by which it was provoked" (1893a, p. 6). At stake here is not simply the power of recollection, but especially by "arousing its accompanying affect" (p. 6), there can be a liberating release, through symbolization. In effect, the abreaction supposes that we give the affect linked to trauma a "verbal expression" that binds it. The conception of abreaction foreshadows, in certain respects, later developments on working-through and construction in psychoanalysis.

Lifting of amnesia causes the resurgence of memories charged with affects; retroactively meaning is given to a traumatic situation, which the subject, overwhelmed and overcome by events, could not grasp at the time. Until the moment of resurfacing, "these experiences are completely absent from the patients' memory when they are in a normal psychical state, or are only present in a highly summary form. . . . [T]hese memories [then] emerge with the undiminished vividness of a recent event" (p. 9). From this point of view, the unconscious would consist of an alteration of normal memory—whence Freud's paradoxical evocation of unconscious memory (for example in 1896 in the "Aetiology of Hysteria" [1896c, p. 212]: "hysterical symptoms are derivatives of memories which are operating unconsciously").

The persistent pressure of lived experience (*Erlebnis*) seeks to lift the veil of amnesia; the strength of the impression (*Eindruck*) in itself inclines toward lifting of amnesia. The mnemic trace of either an external event resonating in the psyche of the subject, or of a purely internal psychic event, seeks repeatedly an outlet toward the perception/consciousness system. Failing to find one, it appears in dreams, screen memories, daydreams, and symptoms. An impulse to memory (*Impuls zur Erinnerung*) exists, directed toward the hallucinatory mode of satisfaction and the identification of representation with perception, sometimes to be found in what Freud called a "mnemic image": a sensory intensity, essentially visual, of the memory of sexual trauma, at the moment of the lifting of amnesia.

With amnesia we don't remember, but with the lifting of amnesia, we remember "too much" in a sense.

Lifting the amnesia confirms the correctness of the psychoanalytic interpretation, but Freud was to distinguish later between the lifting of amnesia and lifting of repression, the latter accompanied by a transformation of the economy, dynamics, and topic of the ego, and obtained more through the analysis of repetition and transference than by recollection.

Indeed, Freud discovered, in his clinical practice as an analyst, that recollection never totally lifts amnesia, in particular infantile amnesia. In 1914, in “Remembering, Repeating, and Working-through” (1914g), he said that the analysis of repetition-compulsion is the best instrument to reconstitute that part of the psychic reality that remains amnesiac: repetition is a “way of remembering” (1914g, p. 150). When “the patient does not *remember* anything of what he has forgotten and repressed, but *acts* it out,” (p. 151), then “the transference is itself only a piece of repetition” (p. 151).

Freud here abandoned a conception of the cure based on the lifting of amnesia and the abreaction of traumatic memories, in favor of the lifting of repression, that is to say the transformation of the psychic organization of the analysand. We should, consequently, treat the neurosis “not as an event of the past, but as a present-day force” (p. 151).

In 1937, in “Constructions in Analysis” (1937d), he expanded the notion of interpretation to include that of construction, proposing to the analysand a hypothetical point of view on his history and on the cause of his symptoms based on an analysis of repetitive behavior, the transference, but also of clues that have been saved from oblivion, which are the “fragments of these memories in dreams” (p. 258). The analysand’s conviction that the construction is correct has the same effect of lifting the symptom and as a full and entire recollection. Freud remained partially attached to his earlier conception of the treatment when he added that the communication to the analysand of a construction can provoke the resurgence of “lively recollections called up in them—which they themselves have described as ‘ultra-clear’” (p. 266): the lifting of amnesia as a proof of the correctness of the construction.

Lifting amnesia has a specific function in the consciousness that a subject can have of their special history and of their identity. In hysteria, the “break-through into consciousness” (1985c [1887–1904], p. 239) is expressed especially through memory, whereas

in other pathologies it may be expressed otherwise, through action or delirium, as Freud had already written to Wilhelm Fliess, on May 2, 1897.

Beyond its essentially phenomenological dimension, the notion of the lifting of amnesia leaned too heavily on a clinical conception that stressed the abreaction of trauma by remembering; Freud distanced himself from this early conception in favor of a concept based on interpretation and construction, aimed at working-through, symbolization, and transformation. Apart from the fact that the project of a total lifting of amnesia is unrealizable because new secondary repressions are still in place, the existence of an original repression would condemn such a project as illusion.

Also, in certain cases of serious trauma (Ferenczi, 1932), there is no lifting of amnesia possible. Mnemic traces exist only in the mode of scattered corporal sensations or of divided affects, which are very difficult of access. In these cases, the abreaction has to be made by means of the emergence of intense affects, which were not felt at the time of the trauma, and not by the lifting of amnesia. The analyst therefore listens for the traumatic resonance of words rather than seeking the resurgence of memories.

FRANÇOIS RICHARD

*See also:* Amnesia.

### **Bibliography**

- Ferenczi, Sándor. (1932). Le traumatisme psychique. In Notes et fragments, *O.C., Psychanalyse* (Vol. 4, pp. 82–97).
- Freud, Sigmund (1896a). Heredity and the aetiology of neuroses. *SE*, 3: 141–156.
- . (1896c). The aetiology of hysteria. *SE*, 3: 186–221.
- . (1914g). Remembering, repeating and working-through (further recommendations on the technique of psycho-analysis). *SE*, 12: 145–156.
- . (1937d). Constructions in analysis. *SE*, 23: 255–269.
- . (1985c [1887–1904]). *The complete letters of Sigmund Freud to Wilhelm Fliess, 1887–1904* (pp. 238–240). Cambridge, MA: Harvard University Press.
- Freud, Sigmund, and Breuer, Josef. (1893a). On the psychological mechanism of hysterical phenomena: Preliminary communication. *SE*, 2: 1–13.

**LIMENTANI, ADAM (1913–1994)**

Adam Limentani, an English psychiatrist and psychoanalyst of Italian origin, was born on July 6, 1913, in Rome and died on September 9, 1994, in London after a long illness. Limentani came from a well-established Roman nonorthodox Jewish family. From an early age he showed superior abilities. He was one of only ten applicants out of three hundred to become a student intern at the Rome Teaching Medical Clinic. However, his achievement was short-lived. In July 1938, just after taking a special competitive examination to gain an appointment at the psychiatric clinic of the University of Rome, he learned from the newspapers that Italians had been declared an Aryan race. With that he lost his position as clinical assistant at the medical clinic.

In December 1938, at the age of 25, he emigrated to London. By then Limentani had developed an interest in psychotherapy, but failing to obtain a psychotherapy post, he decided to get a degree in hygiene and tropical medicine with the aim of emigrating to an underdeveloped African country to practice psychiatry. The outbreak of the Second World War prevented this move. Limentani once said that if he ever wrote an autobiography, he would call it "In adversity." To illustrate this, he could point to his not going to Africa because of the outbreak of World War II and instead returning to psychiatry.

In May 1940 his work with casualties was abruptly interrupted because Italy entered the war, whereupon Limentani became an enemy alien and was interned for six months on the Isle of Man. After his release, he eventually became a major in the Royal Army Medical Corps and was sent to the military hospital in Hertfordshire, where he worked in psychosomatic medicine. Transferred to the military mental hospital in South Wales, he worked from 1941 to 1946 with British and Allied psychiatric casualties.

When he left the army, Limentani obtained a post as government registrar at Shenley Hospital, and it proved an invaluable experience. He could practice as a psychiatrist and develop his interest in psychotherapy with the psychoanalysts in training. It was then that he decided to become a psychoanalyst. In 1962 he obtained a post at the Portman Clinic, which led him to write a number of papers on sexual deviancy and delinquency.

Limentani was elected as an analyst in 1955 and became a member of the British Psycho-Analytical

Society in 1959. After twelve years devoted to training activities, he became president of the British Psycho-Analytical Society in 1974. In 1975 the British society, under his leadership, hosted the twenty-ninth congress of the International Psychoanalytical Association. After this congress Limentani was elected as one of the vice-presidents of the International Psychoanalytical Association with a seat on its council. He was elected president of the International Psychoanalytical Association in 1981, a post he held until 1985. To maintain a link between psychoanalysis and the professional public, from 1978 he took on the role of chairman of the publications committee of the British Psycho-Analytical Society and the Institute of Psycho-Analysis for the following ten years. He took an active interest in the development of psychoanalysis in many different parts of the world. He was able to foster an atmosphere of care and concern for colleagues throughout the world who sometimes worked in isolation or in environments that were either not accepting of, or even hostile to, psychoanalysis. At the time of his death, he was honorary archivist of the International Psychoanalytical Association, and shortly before his death he was elected honorary life vice-president of the International Psychoanalytical Association. In 1966 he wrote *A Brief History of the International Psychoanalytical Association*.

He was a fellow of the Royal College of Psychiatrists and an honorary consultant to the Portman Clinic of London. Though he reached the highest positions in his profession, he never lost his humanity and his warm sense of humor, attached to a boyish mischievousness to which he would at times give quiet expression. Apart from his career, he was a devoted husband, father, and grandfather and enjoyed his family enormously.

MOSES LAUFER

*See also:* British Psycho-Analytical society; Great Britain; International Psychoanalytical Association; Khan, Mohammed Masud Rasa; Société psychanalytique de Paris and Institut de psychanalyse de Paris.

**Bibliography**

Limentani, Adam. (1972). Assessment of analysability: Major hazard in selection. *International Journal of Psycho-Analysis*, 53, 351–362.

———. (1986). Variations on some Freudian themes. *International Journal of Psycho-Analysis*, 67, 235–244.

- . (1989). *Between Freud and Klein: The psychoanalytic quest for knowledge and truth*. London: Free Association Books.
- . (1991). Neglected fathers in aetiology: Treatment of sexual deviations. *International Journal of Psycho-Analysis*, 72, 573–584.
- . (1994). On treatment of homosexuality. *Psychoanalytic Psychotherapy*, 8.
- . (1996). A brief history of the International Psychoanalytical Association. *International Journal of Psycho-Analysis*, 77, 149–156.

### “LINES OF ADVANCE IN PSYCHO-ANALYTIC THERAPY”

Originally planned for Breslau, the Fifth International Psycho-Analytical Congress—the first since the outbreak of the First World War—was eventually held on September 28 and 29, 1918, in Budapest, in the great hall of the Hungarian Academy of Sciences, with Karl Abraham presiding. It was there that Freud read this paper, which was published the following year.

Freud began by comparing the work of the analyst to that of the chemist, but warning against the idea proposed by some people that the analyst’s task was somehow to create a new synthesis from the elements he successfully isolated. For “psycho-synthesis is . . . achieved during analytic treatment without our intervention, automatically and inevitably” (p. 161). The therapeutic way forward, therefore, was rather that “activity” on the part of the analyst which Ferenczi had advocated.

After recalling that “Analytic treatment should be carried through, as far as is possible, under privation—in a state of abstinence” (p. 162), Freud stressed that “we must see to it that the patient’s suffering, to a degree that is in some way or other effective, does not come to an end prematurely” (p. 163), the danger being the weakening of “the instinctual force impelling him towards recovery” (p. 163). It was thus appropriate to put up “energetic opposition” to the substitute satisfactions that patients find in their various distractions, interests, activities, love affairs, and so on. Not to mention the satisfaction to be derived from the transference: “Any analyst who out of the fullness of his heart, perhaps, and his readiness to help, extends to the patient all that one human being may hope to receive from another, commits the same economic

error as that of which our non-analytic institutions for nervous patients are guilty” (p. 164).

Likewise, and contrary to the approach promoted by the Zurich school, Freud argued that the analyst must resist the temptation to educate the patient or “to force our own ideals upon him” (p. 164)—even though, with most patients, “occasions now and then arise in which the physician is bound to take up the position of teacher and mentor” (p. 165).

As examples of “new lines of advance,” Freud cited the active encouragement of phobics to confront their fears and the suppression of the compulsion of obsessional to prolong their treatment ad infinitum.

But the broader prospect opening before psycho-analysis was the mass of patients barred from analytic treatment by reason of their lowly place in society—this despite “the vast amount of neurotic misery which there is in the world” (p. 166). The day would come, Freud felt, when society would acknowledge the importance of mental health and open free clinics “to which analytically-trained physicians will be appointed” (p. 167).

In that event, Freud speculated, “the large-scale application of our therapy will compel us to alloy the pure gold of analysis freely with the copper of direct suggestion” (p. 168)—even, as had been true in the treatment of the war neuroses, with “hypnotic influence.” All the same, concluded Freud, “whatever form this psychotherapy for the people may take, whatever the elements out of which it is compounded, its most effective and most important ingredients will assuredly remain those borrowed from strict and untendentious psycho-analysis” (p. 168).

This text was rich in consequences. For several years, with respect to psychoanalytic practice, its approach underpinned the technical innovations of Freud himself (as when he terminated the treatment of the “Wolf Man”) and above all of Sándor Ferenczi—innovations which, in conjunction with those of Otto Rank, would define deep divisions still felt in the early twenty-first century.

Indeed Ferenczi and Rank soon published a joint work, *The Development of Psychoanalysis* (1924/1925), which shook up the psychoanalytic world and instantly attracted the hostility of the Berliners, with Karl Abraham in the lead. With a view to simplifying psychoanalytic treatment and shortening its duration, Ferenczi and Rank presented, though in a more systematic form, proposals already made by Freud,

among them the use of suggestion and hypnosis, and above all the setting by the analyst of a termination date for the treatment; these considerations were incorporated into Rank's almost simultaneous revival of the sharply contested idea of the "trauma of birth" (Rank, 1924/1929).

On another plane, Freud's venture into "social" issues was to have even more significant repercussions. As early as 1919, Max Eitingon and Ernst Simmel proposed to the Berlin Psychoanalytical Society that a polyclinic be established where the sort of free treatment that Freud had recommended at the Budapest Congress would be offered; a year later such an establishment was opened. Providing treatment naturally meant training more therapists, and the training institute soon set up in Berlin to meet this demand would become, roughly speaking, the prototype for all the similar institutes that were to follow.

The two great and opposing currents that as of 2005 continue to divide the psychoanalytical world—on the one hand research, codified communication, rigor, even orthodoxy, and on the other hand practical innovation, theoretical speculation, and the risk of counter-transference—had made themselves felt well before the 1918 Congress. But clearly Freud's observations, as he rediscovered a public audience at the close of the horrific First World War, contributed greatly to their renewed vigor and to their repercussions, which psychoanalysts still have to address in their day-to-day practice.

ALAIN DE MIJOLLA

*See also:* Abstinence/rule of abstinence; Active technique; Berliner Psychoanalytisches Institut; Hietzing Schule/Burlingham-Rosenfeld School; Technique with adults, psychoanalytic; Psychotherapy.

### Source Citation

Freud, Sigmund. (1919a [1918]) Wege der Psychoanalytischen Therapie. *Internationale Zeitschrift für ärztliche Psychoanalyse*, 5, 61–68; *GW*, 12, 183–94; Lines of advance in psycho-analytic therapy. *SE*, 17: 159–68.

### Bibliography

Colonomos, Fanny. (1985). On forme des psychanalystes.- Rapport original sur les dix ans de l'Institut psychanalytique de Berlin 1920–1930.

Ferenczi, Sándor, and Rank, Otto. (1925). *The development of psychoanalysis* (Caroline Newton, Trans.). New York/

Washington, DC: Nervous and Mental Disease Publishing Co. (Original work published 1924)

Rank, Otto. (1929). *The trauma of birth*. London: Kegan Paul, Trench, Trubner. (Original work published 1924)

## LINGÜÍSTICA, INTERACCIÓN COMUNICATIVA Y PROCESO PSICOANALÍTICO

David Liberman distinguishes in his book between several models of "communication theory" with a view to using them in clinical psychoanalysis. He was interested in the influence of the modes of information transmission and reception in the transference because the patient's form of linguistic expression is a communication that is just as important as the content of the utterance. Theories of communication and the real and concrete effects that pathological communication produces on the mind are illustrated by clinical examples in psychoanalytic transference. We can see the influence of Gregory Bateson (1951), Paul Watzlawick (1967), and Rudolf Carnap (1942).

The first volume of the work is devoted to providing a methodological explanation of psychoanalysis as a science, as well as the empirical models and modes of corroborating hypotheses used in this domain. The second and third volumes present clinical examples of the reception and transmission of messages in the course of a session. The author introduces the notion of style, modeled on literary styles: narrative style (obsessional), epic style (psychopathic), and lyrical or emotional style (depressive).

Liberman presents a new typology founded not on psychiatry but on the three axes of communication theory—syntactic, semantic, and pragmatic—and their respective pathological distortions. Syntactic distortion appears through parapraxes in hysteria, semantic distortion through the altered meaning that the patient gives to a sentence, and pragmatic distortion through the real and concrete effects produced on the mind of the receiver, for example the use of the imperative mode, double meanings, and paradoxes.

Another original contribution from the author is the microscopic study of sessions with the help of notes and recordings in an effort to observe the slight syntactic and paraverbal changes that take place in the course of a treatment. Patients' tangential and disqualifying responses are also studied. For example, we can observe that the analysand's recourse to responses like

“perhaps,” “I’m not sure that’s true,” “I have my doubts” are a means of discrediting the interpretation. Microscopic analysis offers a more scientific basis—especially with the help of modern linguistic theories—and helps us to understand the process of the counter-transferencecountertransference, which is apprehended as an emotion to be decoded.

This work is one of the most influential in terms of its effect on how Latin American psychoanalysts are trained.

DAVID ROSENFELD

See also: Argentina; Liberman, David; Linguistics and psychoanalysis.

### Source Citation

Liberman David. (1971). *Linguística, Interacción comunicativa y Proceso psicoanalítico*. Buenos Aires: Adiciones Nueva Visión.

### Bibliography

Bateson, Gregory, et al. (1951). *Communication: The social matrix of psychiatry*, New York: W. W. Norton.

Carnap, Rudolf. (1942). *Introduction to Semantics*. Cambridge, MA: Harvard University Press.

———. (1978). Affective response of the analyst to the patient’s communications. *International Journal of Psycho-Analysis*, 59 (2–3), 335–340.

Watzlawick, Paul, Beavin, Janet Helmick, and Jackson, Don D. (1967). *Pragmatics of Human Communication*. New York: W. W. Norton.

## LINGUISTICS AND PSYCHOANALYSIS

In 1890 the “science of language” had not yet become “general linguistics,” the “fundamental science” of the humanities it would become following the work of Ferdinand de Saussure (1857–1913). Philologists studied *scripta* (written traces) and the history of languages but not their origins or that of the original language (*Ursprache*), a search that was felt to be irrelevant to the science of language, according to the first article of the bylaws of the Société linguistique de Paris, composed in 1866.

From the point of view of linguistics, Hans Sperber’s article on the “sexual origins of language” (1912)

was more an application of Freudian theory than a form of linguistic research. Émile Benveniste’s rebuttal of Carl Abel’s claims about the opposite meanings of words (“Über den Gegensinn der Urworte,” 1885) starts from the same point: The discursive use of the euphemism or antiphrasis does not justify this claim. Moreover, there is no primitive language as far as linguists are concerned. Language is a system of signs, articulated through a process of differentiation, that organizes the first representation of the world by and for the speaking subject. At the beginning of the twentieth century, the distinction “*langage/langue*”—language as spoken versus language as system—used by de Saussure in his classes and published in the *Course on General Linguistics* after his death (1916), was not widely known.

Some philologists, however, became interested in spoken language, in everyday words, in the nature of the “system” or internal structure of language (*langue*). By collecting slips of the tongue, Rudolf Meringer (1895) attempted to determine the laws of evolution and the internal operation of *Sprachorganismus* (the organism of language), comparing it to Freud’s “language apparatus” (1891b). Freud borrowed eight examples from Meringer’s corpus, including the opening and closing remarks of the president of parliament (1901b). Meringer failed to be amused (1907) by Freud’s admiration for the quoted text. Freud in return wrote an ironic comment (1910e), distancing himself from Meringer on the basis of their divergent understanding of slips of the tongue. The two men held different points of view: Meringer prefigured the Saussurian break entailing the internal synchronic description of the structure of languages (that is, at the time of spoken use). His insistence on speech (*parole*)—which revealed the underlying structure—implied an emphasis on orality, the primary characteristic of languages.

De Saussure thus gave the world approximately five thousand languages and rejected the notion of “primitive” languages, which were languages with no written tradition. According to de Saussure, a language should be considered a highly organized structure, a “system of internal relations,” whose elements were arbitrary and differential and could be analyzed along two different axes: the paradigmatic (or associative) axis, the axis of elements that were “absent”; and the syntagmatic axis, the axis of elements that were “present.” These elements were defined in negative terms: “In language there is only difference.” On the plane of



sound as well as on the plane of meaning, each element is what the others are not (this was de Saussure's concept of "value"). The axis of the spoken chain can be used to postulate the temporal linearity of the sound (or acoustic) aspect of signs, that is, the "linearity of the signifier." A language is, thus, a set of articulatory, acoustic, and representative (or symbolic) conventions that are socially imposed on the speaker, a *Weltanschauung*, a treasure deposited in the individual by the mass of speakers.

The same position is found in the work of Édouard Pichon (linguist and psychoanalyst, founding member of the Paris Psychoanalytic Society, then its president in 1938), from whom Jacques Lacan borrowed the idea of "foreclosure" (*Verwerfung*). From de Saussure's work, Lacan derived the concepts of the "treasure of signifiers," the unconscious structured as a language, and the condition of the unconscious. From Roman Jakobson (1963) he derived the concepts of metaphor (paradigmatic) and metonymy (syntagmatic), and reworked the concepts of condensation and displacement. Lacan also borrowed from de Saussure the idea of the arbitrariness of the sign and its duality: signified and signifier. The signified is the mental image, the concept; the signifier the acoustic image (or phonetic form). This relationship is reversed and hierarchized in Lacan (S/s) with an extreme (non-linguistic) expansion of the signifier.

Saussurian arbitrariness—which is what makes his work so original—does not refer to the lack of motivation between object and sign (word) (*Sache/Zeichen*) discussed in Plato's *Cratylus*, but to the absence of a one-to-one relation between elements of the system of signifieds and signifiers. The concept of "double articulation" (Martinet, 1960/1964) demonstrates this: for linguists no meaning can be attributed to a phoneme or letter, something a linguist shaped by psychoanalysis like Ivan Fonagy (1970) rejects. For Fonagy, for example, language and unconscious, language and drive, are contiguous.

The same was true for Pichon, the author, with Jacques Damourette, of a voluminous grammar text and a large number of articles. It was Pichon who created the concepts of *pensée-langage*, which reflects the separation of form and content, and *sexuisemblance*, which reflects the connection between gender and sex. His work on negation (1928) and the grammatical person (1938), criticized by Benveniste as too "psychological," serves as the premise for the concept of the "shifter" in

Jakobson's work, and research on "enunciation" for Benveniste. Among linguists, including contemporary linguists who speak of the (re)introduction of the subject into their field (through pragmatics, the analysis of meaning or discourse), the subject is always (or almost always) a controlling intentional subject. The failure to identify intentionality, moreover, is what ended the Saussurian analysis of anagrams (the search for a proper name buried—disseminated—in the poetic chain), although they can be understood as a search for an unconscious subject.

This conscious and controlling subject marks the difference between linguistics and psychoanalysis. Here, their epistemological terrain is distinct. Linguists and psychoanalysts apprehend the same words in different ways. Linguists first try to describe languages and construct a scientific theory of their workings. Their concern is one of generalized objectivity, which could be described as an Aristotelian approach. Consequently, they attempt to eliminate any subjectivity, while psychoanalysts acknowledge it as part of the process of association. The analysts' goal is not to put forth a theory of language but of the unconscious. This is why there are so many differences between the two fields in spite of the many borrowings by psychoanalysts from linguists (philologists for Freud) in the first half of the twentieth century.

Today, however, the situation is reversing itself, and some psychoanalysts consider the near "assimilation" of the mental apparatus to the language apparatus to be a failure (Green, 1984, 1989). Moreover, the number of linguists and semiologists who acknowledge the influence of psychoanalytic theory in the humanities is growing. For example, research on the contiguity between these two fields (Michel Arrivé, Jean-Claude Milner) has been conducted by linguists who have undergone analysis or who are analysts themselves; they have introduced psychoanalytic ideas into research on sign systems, writing, enunciation, modes of text analysis, meaning, and so forth. Links between the fields exist despite the fact that their founders never met. Freud may have seen de Saussure's name quoted by Meringer; de Saussure may have seen Freud's in a report on *The Interpretation of Dreams* written by one of his colleagues at the University of Geneva (Théodore Flournoy). And although Freud never read de Saussure, it is certain that he heard him referred to as the "father" and author of the *Course of General Linguistics*. For one of Freud's patients was

Raymond de Saussure, the son of Ferdinand, and Freud wrote a preface to Raymond's *The Psychoanalytic Method* (1922), where his father's book is mentioned.

ANNE-MARIE HOUBEINE

See also: Language and disturbances of language.

### Bibliography

- Abel, Carl. (1885). Über den Gegensinn der Urworte. *Sprachwissenschaftliche Abhandlungen*, pp. 313–367.
- Arrivé, Michel. (1994). *Langage et psychanalyse, linguistique et inconscient: Freud, Saussure, Pichon, Lacan*. Paris: Presses Universitaires de France.
- Fonagy, Ivan. (1970). Les Bases pulsionnelles de la phonation. *Revue française de psychanalyse*, 34 (1), 101–136.
- Green, André. (1984). Le langage dans la psychanalyse. In Green, André, Diatkine, René, Jabes, Edmond, Fain, Michel, and Fonagy, Ivan, *Langages*. Paris: Belles Letres.
- . (1989). Pulsion de mort, narcissisme négatif, fonction désobjectalisante. In his *La pulsion de mort*. Paris: Presses Universitaires de France.
- Jakobson, Roman. (1963). *Essais de linguistique générale*. Paris: Minuit.
- Martinet, André. (1964). *Elements of General Linguistics* (Elizabeth Palmer, Trans.). Chicago: University of Chicago Press. (Original work published 1960)
- Meringer, Rudolf, and Mayer, Carl. (1895). *Versprechen und verlesen: Eine psychologisch-linguistische studie*. Stuttgart: Göschense Verlagsbuchhandlung.
- Milner, Jean-Claude. (1978). *L'amour de la langue*. Paris: Seuil.
- Pichon, Édouard. (1928). Position du problème de l'adaptation réciproque entre la société et les psychismes exceptionnels. *Revue française de psychanalyse*, 2 (1), 135–170.
- . (1938). La personne et la personnalité vues à la lumière de la pensée idiomatique française. *Revue française de psychanalyse*, 10 (3), 447–461.
- Pichon, Edouard, and Damourette, Jacques. (1925). La grammaire en tant que mode d'exploration de l'Inconscient. *L'Évolution psychiatrique*, 1, 237–257.
- Saussure, Ferdinand de. (1983). *Course in general linguistics*. (Charles Bally and Albert Sechehaye, Ed.; Roy Harris, Trans.). London: Duckworth. (Original work published 1916)
- Sperber, Hans. (1912). Über den Einfluss sexueller Momente auf Entstehung und Entwicklung der Sprache. *Imago*, 1 (5), 405–453.

### Further Reading

- Harris, Adrienne. (1995). Introduction: Symposium on psychoanalysis and linguistics. *Psychoanalytic Dialogues*, 5, 615–618.
- Holland, Norman. (1999). Cognitive linguistics. *International Journal of Psychoanalysis*, 80, 357–364.

## LINKING, ATTACKS ON

Wilfred Bion's notion of "attacks on linking" was first expounded in "Attacks on Linking" (1959) as part of his innovative work on psychosis. Attacks on linking are destructive attacks from the psychotic part of the personality directed against all links between objects. An internalization of an "ego-destructive super-ego," as Bion called the figure which attacks links of emotion and reason between objects, occurs when the relationship between mother and infant lacks the normal links of primary communication by projective identification. He thinks that the chief source of the failure of primary communication in such cases stems from an inborn disposition of excessive hate and envy in the infant whose situations is worsened if the mother is unreceptive, and diminished but not abolished if the mother can introject the infant's violent feelings while remaining balanced.

Bion showed the theoretical importance of the concept of "attacks on linking" for understanding some symptoms in borderline patients. Lacking a state of mind capable of making links for growth, the patient feels that his mind is an ongoing disaster which he fears is incapable of resolution. Moreover, since there is a deficiency of curiosity in his psyche, any development which depends on enquiry is impossible, and the links in his mind remain perverse, cruel, and sterile.

In clinical practice the concept of "attacks on linking" shifts the analyst's attention in an important way—from the nature of the object to the nature of the relations between objects, i.e., from structures to functions. Attacks on linking manifest themselves in the attempted destruction of the inner mental functioning of patient and analyst, and on the verbal and nonverbal communication which is the link between them. Problems in the analysis tend to become focused not on why but on what, in the sense of what the function of the analysis and the analyst are for the patient.

Bion's notion of "attacks on linking" fits Freud's description in *Civilization and its Discontents* of the

death instinct as an instinct seeking to dissolve units. It is also an elaboration of Klein's concept of splitting.

EDNA O'SHAUGHNESSY

*See Also:* Emotion; Learning from Experience; Love-Hate-Knowledge (links L/H/K); Selected fact; Subject's castration; Symbiosis/symbiotic relation; Vertex.

### **Bibliography**

- Bion, Wilfred. (1959). Attacks on linking. *International Journal of Psycho-Analysis*, 40 (5–6), 308.
- Freud, Sigmund. (1930a [1929]). *Civilization and its discontents*, SE, 21: 64–145.
- Klein Melanie. (1946). Notes on some schizoid mechanisms, *The writings of Melanie Klein* (Vol. 3, pp. 1–24). London: Hogarth Press.

---

## **LISTENING**

Listening must be distinguished from audition. Audition is the function and exercise of the sense of hearing, whereas listening is much more global. Listening is simultaneously being sensitive to words, the voice that carries them, and the broader context of human communication. The relationship that links patient and psychoanalyst can be understood as listening, each listening to the other.

The psychoanalyst's relation with the patient is different from that of ordinary life. The psychoanalyst listens in silence (silence is an opening into the unconscious), listens without according priority to the content of the words, listens to the voice and the body and the affects expressed through them. The analyst's sensitivity to the effects of the voice is amplified by being in a state of free-floating attention, unaffected by the requirements of dialog, the need to respond, the interplay of ideas, and considerations of politeness. Intonation is a subtle vocal posture and expression, and tone creates a music that influences the analyst's counter-transfer and warns the analyst against repression. Analytical listening is accompanied by a benevolent, receptive attitude that abstains from all critical evaluation and judgment. Such listening affords patients a space in which, free from visual confrontation, they can deploy their imagination in free association. The psychoanalyst's listening is the patient's guarantee that the Other is present, referring the patient back to the primordial Other and all its successive representations.

By listening to what the patient says, the analyst becomes sensitive to the former child, animated by the "instinct to listen" (Bernard This, Piera Aulagnier) to the sounds of the primal scene, among other things.

For patients, the psychoanalyst's listening enables them first to hear a voice that refers them back to the benevolent voice of the first stages of life and that they can progressively introject while engaged in free-floating listening, and then to hear words enabling them to bring their histories to life by deploying their own unconscious forces. Patients have a special dialog with the analyst that requires reworking their energies in as complete and free a way as possible. Listening to the analyst's words shatters thought systems and promotes change, the analyst's reflections being brief, incomplete, and ambiguous interventions rather than explanatory interpretations. The two types of listening thus promote the elaboration of a powerful synergy.

MARIE-FRANCE CASTARÈDE

*See also:* Cathartic method; Evenly-suspended attention; Face-to-face situation; Fundamental rule; Initial interview(s); Music and psychoanalysis; Psychoanalytic treatment; "Recommendations to Physicians Practicing Psycho-Analysis".

### **Bibliography**

- Gillibert, Jean, and Wilgowicz, Pérel (Eds). (1993). *L'ange exterminateur*. Brussels: Éditions Universitaires de Bruxelles.
- M'Uzan, Michel de (1994). *La bouche et l'inconscient*. Paris: Gallimard.
- Vasse, Denis. (1974). *L'ombilic et la voix*. Paris: le Seuil.

---

## **LITERARY AND ARTISTIC CREATION**

Freud considered literary creations and, more generally, artistic creations enigmatic because of their ability to produce emotion in the spectator (the essence of art) and in regard to the origin of themes chosen by authors. Far from contenting himself with applying the psychoanalytic method to the analysis of works of art, Freud emphasized the heuristic value of such works for the psychoanalytic study of the human psyche. Literature and art occupy a considerable place in his work (the works of Goethe and Sophocles being among the first), as in the work of his disciples (Nunberg and Federn, 1962–1975).

In works of literature Freud identifies and confirms several clinical observations, the most perceptive being the Oedipus complex in Sophocles' *Oedipus Tyrannus* and his analysis of Hamlet in Shakespeare's *Hamlet*. Freud treats the characters of fiction, more than their authors (pathography), as true clinical cases. Freud (1907a [1906]) wrote that Wilhelm Jensen's fantasy (*Gradiva*) could be subtitled a "psychiatric study," although he simultaneously questions the value of the subtitle, because the author ignores (as does psychoanalysis itself) the split between the normal and the pathological.

It is easy to see how novelists would interest Freud, since their literary creations are based on self-analysis: "[The author of a literary work] directs his attention to the unconscious in his own mind, he listens to its possible developments and lends them artistic expression instead of suppressing them by conscious criticism. Thus he experiences from himself what we [psychoanalysts] learn from others—the laws which the activities of this unconscious must obey" (1907a [1906], p. 92). The novelist is a psychoanalyst who lacks the technique and patients but is capable of incorporating in his art his knowledge of the unconscious acquired through self-observation. To the extent that the author projects himself into his characters, this disposition justifies describing what authors do as psychoanalytic analysis. Thus in "Dostoyevsky and Parricide" (1928b [1927]), Freud simultaneously analyzes *The Brothers Karamazov* and Dostoyevsky, and he deepens our understanding of the concept of castration through his analysis of hysterical epilepsy.

The third element in the psychoanalytic study of literary creation, after the characters and the author, is the reader. In "Psychopathic Characters on the Stage" (1942a [1905–1906]) and "Creative Writers and Day-Dreaming" (1908e [1907]), Freud emphasizes what the reader gains by identifying with the hero. In addition to Aristotelian catharsis, such identification "gives people the sense, which they so much desire, of a raising of the potential of their psychical state" (1942a [1905–1906], p. 305). At first, it is surprising to see pleasure and tension identified in this way, but there is a simultaneous discharge of the tension involved, since the reader continues to enjoy the contrast between the tribulations of the hero and his own personal security. In literature there are several sources of satisfaction: pleasure in the heroic revolt against the father or his representations, masochistic pleasure in

identification with the hero, and pleasure in not being threatened in the real world.

In Freud's work, artistic creation occupies a less important place than literary creation. In *Leonardo da Vinci and a Memory of His Childhood* (1910c), Freud mainly emphasizes the conflict between artistic realization and scientific investigation. But Freud also examined the origin of the design of the painting *Mona Lisa* (the smile of Mona Lisa, said to be Anna Metterza). His examination led to an interpretation that associated a vulture with Leonardo's memory traces from childhood. The risks and limitations of such interpretations are illustrated by Freud's famous translation error, since the "vulture" was in fact a kite.

The fecundity of such study of works of art extends well beyond the question of artistic creation, for the psychoanalytic study of works of art develops new insights into homosexuality, again attesting to its heuristic value. In turn, analysis of a work of art can implicate the analytic method, as shown in "The Moses of Michelangelo" (1914b), which is carried out as if Freud were listening to a patient, incorporating details that would generally be overlooked. Here, as elsewhere, Freud compares his point of view with those of other disciplines, especially art history.

After Freud many other authors continued his work on creativity, enlarging the study to other fields (primarily music). It is worth noting that Freud did not include in his study the field he knew best, namely theoretical creativity. This oversight reflects the division he established between fantasy and critical reason, while he himself served as proof of the effectiveness of theoretical fantasies (the witch of metapsychology).

Since Freud, literary and artistic creation has also been extensively studied in its relation to psychopathology (psychosis), and this has given rise to clinical developments of unequalled value in the field of "art therapy."

SOPHIE DE MIJOLLA-MELLOR

*See also:* Applied psychoanalysis and the interaction of psychoanalysis; Autobiography; Breton, André; "Claims of Psycho-Analysis to Scientific Interest"; "Creative Writers and Day-Dreaming"; Creativity; Fantasy (reverie); Repetition; Reverie; Sachs, Hanns; Sublimation.

### **Bibliography**

Freud, Sigmund. (1907a [1906]). Delusions and dreams in Jensen's "Gradiva." *SE*, 9: 1–95.

- . (1908e [1907]). Creative writers and day-dreaming. *SE*, 9: 143–153.
- . (1910c). Leonardo da Vinci and a memory of his childhood. *SE*, 9: 63–137.
- . (1914b). The Moses of Michelangelo. *SE*, 13: 209–238.
- . (1928b [1927]). Dostoevsky and parricide. *SE*, 21: 177–194.
- . (1942a [1905–1906]). Psychopathic characters on the stage. *SE*, 7: 303–310.
- Nunberg, Hermann, and Federn, Ernst. (1962–1975). *Minutes of the Vienna Psychoanalytic Society*. New York: International Universities Press.

## LITERATURE AND PSYCHOANALYSIS

Since the origins of psychoanalysis, the field has displayed a powerful set of connections to literature, one that might even be called a mutual fascination. Literary criticism, primarily in its academic form, has been the major mediator between the two disciplines. The three domains of psychoanalysis, literature, and literary criticism (or literary theory) intertwine and seek to use each other in distinctive ways. Psychoanalysis has occasionally sought to explain literature but far more often uses literature as a source or exemplar for psychoanalytic conceptions themselves. Literary criticism has sought to use psychoanalytic theory to explain literature, and even literature itself has sometimes sought to exploit psychoanalysis for creative purposes.

The relation of these three domains manifests particular predilections. For example, the fascination of literary critics with psychoanalytic theory from Sigmund Freud to Jacques Lacan has been far greater than the interests of historians in the same conceptions despite the fact that such theories can be as easily applied to historical phenomena as to literary ones. The field of psycho-history remains relatively marginal in American and European universities, while psychoanalytic concepts permeate most branches of literary studies. Within literature departments, interest in psychoanalytic theory eclipses attention (when there is any at all) to other systems of psychology, like behaviorism or neurological/biological approaches. Yet this does not echo the balance of forces in the same universities' psychology departments, where the situation is almost opposite.

Affinities between literature and psychoanalysis are both cultural and structural. Culturally, it is not a

coincidence that the two greatest literary dissections of the modern soul (James Joyce's *Ulysses* and Marcel Proust's *A la recherche du temps perdu*) appeared around the same time as Freud's foundational *Interpretation of Dreams*. This temporal connection is less a question of influence than of participation in a common culture. Structurally, psychoanalysis elicits and tells stories. Like most of literature, it is structured around narratives. Talk therapy is necessarily mediated by language. Psychoanalysis explores the complexities of the human soul, long a major preoccupation of literature. Already true for Freud, this structural affinity was deepened by Jung, whose system of archetypes is linked both to the creative imagination and to myths, using the universality of myths to demonstrate the collective unconscious. Lacan continues the trend with his notion that the unconscious is organized on the principles of human language (as these were conceptualized by the structural linguistics of Ferdinand de Saussure and Roman Jakobson). Language is transformed by Lacan from a mediator between the unconscious and the therapeutic realm to something that defines the unconscious itself.

Freud turned to literature both for evidence of his mappings of the unconscious and to explain what he found there. The Oedipus story, which reached Freud through the literary medium of Sophocles's tragedy to become the Oedipus complex, is the best-known example of this phenomenon. Bruno Bettelheim's classic *The Uses of Enchantment* similarly exploited the world of fairy tales to illuminate child psychology, and vice versa. More recently, in the Jungian school, Helen M. Luke in her *Dark Wood to White Rose* uses Dante's *Divine Comedy* for evidentiary, explanatory, and psycho-therapeutic purposes. Lacan himself turned his attention to Shakespeare and Edgar Allan Poe. A legion of writers from the therapeutic community has explored the psychoanalytic bases of fairy tales, popular literature, and even the texts of the Bible.

Such connections are possible because psychoanalytic theory has always seen literature and the arts generally as owing much of their appeal to their ability to express unconscious content in masked form, as well as their ability to act as vehicles of fantasy, and, in Freud's case particularly, as socially acceptable sublimations of erotic drive.

The greatest influence of psychoanalysis on literary production has probably been to add legitimacy to the already-existing trends towards greater psychological

introspection and towards more prominent and franker discussions of sexuality. Though Freud was never an exponent of sexual freedom, merely arguing that his own culture took sexual repression too far, wider circles have treated him as a liberator of sexual expression, whether to blame him or to laud him for this. (Would we have had Henry Miller without Freud?)

Between the world wars in the twentieth century, the politico-artistic school of surrealism championed psychoanalysis as an overture to new aesthetic domains. This impact has probably been clearest and longest in surrealist visual arts. But the surrealist literary school developed the practice of automatic writing as a way of tapping into the unconscious, all this under the influence of the Freudian revolution in psychology.

The closest connection between literature and psychoanalysis has always been articulated by the academic field of literary criticism or literary theory. In the United States, where the acceptance of Freud was earlier and greater than in Europe, Frederic C. Crews, Norman Holland, and Harold Bloom were among the most visible members of a large school of literary criticism that sought to apply Freudian concepts to the explication of literary texts. Crews and Holland later shifted positions. Crews to a more critical view of Freud, and Holland, more recently, to an interest in cognitive psychology and neurobiology.

Following the fashion for French theory, Jacques Lacan became increasingly prominent, contributing, for example, to a fascination with the idea of desire as fundamental to the nature of literary texts. The Slovenian Slavoj Žižek, who uses Lacan (along with Marxist theory) in his literary and cultural analyses, has become increasingly influential in Europe and America. While feminist literary critics have challenged specific conclusions of psychoanalytical schools from Freud to Lacan, they have generally done so more in an attempt to redefine and recuperate the psychoanalytic universe than to set it aside.

Perhaps most typical of the affinities between literature, literary criticism, and psychoanalysis has been the fact that some figures have been able to master all three. The protean writer Julia Kristeva, for example, is at once a trained psychoanalyst, a well-known literary critic (whose writings use both literature and psychoanalysis to deepen the understanding of each), and a successful author of imaginative fiction. Thus, while in the mass media interest is increasingly turning to drug

therapies and neurobiological explanations of behavior, elite culture manifests a continuing interpenetration of the worlds of psychoanalysis and literature. The case of Norman Holland, though it may portend future trends, remains atypical.

ALLEN DOUGLAS AND FEDWA MALTI-DOUGLAS

*See also:* Applied psychoanalysis and the interaction of psychoanalysis; Autobiography; Literary and artistic creation; Shakespeare and psychoanalysis.

### **Bibliography**

- Bettelheim, Bruno. (1997). *The uses of enchantment: The meaning and importance of fairy tales*. New York: Vintage.
- Felman, Shoshana (Ed.). (1982). *Literature and psychoanalysis. The question of reading: Otherwise*. Baltimore, MD: Johns Hopkins University Press.
- Lacan, Jacques. (1966). *Écrits* (Vol. I). Paris: Editions du Seuil.
- Luke, Helen M. (2000). *Dark wood to white rose: Journey and transformation in Dante's Divine Comedy*. New York: Parabola Books.
- Žižek, Slavoj. (1989). *The sublime object of ideology*. London, New York: Verso.

## **LITTLE ARPÅD, THE BOY PECKED BY A COCK**

“Ein kleiner Hahnemann” (a little cock-boy) is the fictitious name Sándor Ferenczi, in 1913, gave to little Arpåd, a previously well-balanced five-year-old boy who suddenly decompensated, the pathology comprising a set of perversions and regressions associated with modifications in language and behavior. The case is an example of an on-going psychotic phase after trauma: “A chicken or a capon with yellow feathers (sometimes he said brown) bit his penis and Ilona, the chamber maid, dressed the wound. Then they cut the cock's throat and it ‘dropped dead’” (Ferenczi, 1927).

Little Arpåd's pathology became manifest after a latency period of one year without any apparent disorder except perhaps a compulsion to masturbate. (This compulsion called for an investigation into any threats made to little Arpåd.) During his consultation with Ferenczi, little Arpåd was hypomaniac, with sadistic fantasies about the cruel punishments he imposed on himself, religious ruminations, and megalomaniac plans to marry all the women around him, like a

veritable “village cock” (identification with the aggressor). In *Totem and Taboo* (1912–1913a), Freud takes this description as an example of “positive totemism,” comparable to the case of “little Hans,” where we find displaced manifestations of ambivalent affect and identification with the totemic animal.

This story, a clinical illustration of genital trauma experienced prior to puberty, is paradigmatic in Ferenczi’s work. But alongside the sexual wound acting as a trigger (“We think of fruit that becomes too quickly ripe and sweet when injured by the beak of a bird, and the precocious maturity of a worm-eaten fruit,” as Ferenczi was to later write in 1949), there is a threat of castration coming from the family environment prior to the trauma.

PIERRE SABOURIN

*See also:* Child analysis; Identification.

### **Bibliography**

Freud Sigmund. (1912–1913a). Totem and taboo. *SE*, 13: 1–161.

Ferenczi Sándor. (1927). Ein kleiner Hahnemann. In his *Bausteine zur Psychoanalyse*: Vol. 2, *Praxis* (pp. 185–195). Leipzig: Internationaler Psychoanalytischer Verlag. (Original work published 1913)

———. (1949). Confusion of tongues between adults and the child: The language of tenderness and of passion. *International Journal of Psycho-Analysis*, 30, 225–230. (Original work published 1933)

---

**LITTLE HANS, CASE OF.** *See* “Analysis of a Phobia in a Five-year-old Boy” (Little Hans)

---

### **LOEWENSTEIN, RUDOLPH M. (1898–1976)**

A physician and training analyst, Rudolph M. Loewenstein was born in Lodz, Poland, on January 17, 1898, and died in New York on April 14, 1976.

Born into a Jewish family, Loewenstein attended secondary school in Zurich, then pursued studies in medicine and neurology in Berlin, where he trained at the Psychoanalytic Institute (1923–1925). He was analyzed by Hanns Sachs, and probably worked under the supervision of Max Eitingon. He was admitted as a

member of the German Psychoanalytic Society (DPG) and in 1925 became an assistant at the outpatient clinic, where he gained recognition as a young and brilliant training analyst.

Eitingon then recommended Loewenstein to René Laforgue to train other analysts. A polyglot, capable of expressing himself with equal fluency in Polish, German, English, and French, he had no difficulty practicing analysis in the various countries in which he was to live. He settled in Paris as a training analyst in 1925 and trained the first generation of analyzed analysts. In 1926 he participated, along with Laforgue, Eugénie Sokolnicka, Marie Bonaparte, and others, in the creation of the Société psychanalytique de Paris (SPP, Paris Psychoanalytic Society) and became the society’s secretary. He also contributed, in 1927, to the creation of the *Revue française de la psychanalyse*, financed by Bonaparte, through whom he met Sigmund Freud several times. He became a naturalized French citizen in 1930 and resumed his studies, earning baccalaureate and doctorate degrees in medicine; the defense of his thesis, “La conception psychanalytique des troubles de la puissance génitale chez l’homme” (The psychoanalytic conception of male sexual impotency), in 1935, was presided over by Professor Claude Henri. He was director of a psychoanalytic seminar at the SPP until 1939; that year he was mobilized as a doctor in the French army, where he was decorated with the Croix de Guerre. After the armistice of 1940 he took refuge in Marseilles, where he practiced and taught psychoanalysis up until his departure for the United States in 1942.

Forced into exile, he settled in New York in 1943, maintaining his institutional and personal connections with French psychoanalysis, for which he was the New York correspondent. Rapidly recognized as a training analyst, he was soon enlisted to fill all the major institutional functions: president of the New York Psychoanalytic Institute (1950–1952), secretary and then president of the New York Psychoanalytic Society (1959–1961), president of the American Psychoanalytic Association from 1957 to 1958, and finally vice president of the International Psychoanalytic Association (IPA) from 1965 to 1967.

In 1952 Loewenstein published *Christians and Jews: A Psychoanalytical Study* (published in French under the title *Psychanalyse de l’antisémitisme*), but in terms of theory, he is mainly known as the cofounder of the new American psychoanalytic school of the

1950s, and for his work in ego psychology; his name remains associated with those of Ernst Kris and Heinz Hartmann, his collaborators in research. Taking up a point that was indicated in Freud's work, but that he developed into a theory, ego psychology, he gave privileged status to the unconscious ego over the instinctual drives and moved it towards the center of the psychic system.

This theory has been called a psychology of adaptation, which Loewenstein was to expound and defend in "Rapport sur la psychologie psychanalytique de H. Hartmann, E. Kris et R. Loewenstein" (Report on the psychoanalytic psychology of H. Hartmann, E. Kris, and R. Loewenstein), presented to the Twenty-sixth Congress of French-speaking Psychoanalysts, held in Paris in 1965. Unanimously criticized in Europe, ego psychology is certainly historically linked to the issue of immigration.

At the end of his life Loewenstein was working with Milton Horowitz on the theory of psychoanalytic technique, trying to conceptualize his five years of practice as a training analyst.

Loewenstein played an important institutional role within the psychoanalytic community, not only in the three countries where he practiced, but also on an international level (IPA). Jacques Lacan underwent an analysis with him—terminated too soon, against the advice of his training analyst. He was also the training analyst for Sacha Nacht, Daniel Lagache, Michel Cénac, Pierre Mâle, Georges Parchemeney, John Leuba, and others. Supervisor and later a friend of Marie Bonaparte, he helped her with her 1935 translation of Freud's *Five Lectures on Psycho-Analysis*.

MICHELLE MOREAU RICAUD

*Work discussed: Christians and Jews: A Psychoanalytical Study.*

*See also:* Abstinence/rule of abstinence; Congrès des psychanalystes de langue française des pays romans; Ego; Ego (ego psychology); France; Libido; New York Psychoanalytic Institute; Racism, anti-Semitism, and psychoanalysis; *Revue française de psychanalyse*; Société psychanalytique de Paris and Institut de psychanalyse de Paris; United States.

### Bibliography

Loewenstein, Rudolph M. (1928). La technique psychanalytique. *Revue française de psychanalyse*, 2 (1), 113–134.

———. (1932). Un cas de jalousie pathologique. *Revue française de psychanalyse*, 5 (1), 554–585.

———. (1935). *La conception psychanalytique des troubles de la puissance génitale de l'homme*. Paris: Denoël & Steele.

———. (1952). *Christians and jews: A psychoanalytical study*. New York: International Universities Press.

Loewenstein, Rudolph M., Kris, Ernst, and Hartmann, Heinz. (1975). *Éléments de psychologie psychanalytique*. Paris: Presses Universitaires de France.

---

## LOGIC(S)

*Logic* refers to the formal structures determining a coherent order in a sequence of ideas. With its notion of the primal, psychoanalysis has extended the question of logic beyond conscious rational thought and developed hypotheses on the primitive modalities (modes) of representation.

According to Freud in the "Formulations on the Two Principles of Mental Functioning" (1911b), "It is probable that thinking was originally unconscious in so far as it went beyond mere ideational presentations and was directed to the relations between impressions of objects, and that it did not acquire further qualities, perceptible to consciousness, until it became connected with verbal residues" (p. 221). The earliest psychoanalytic view of logic is thus limited to connections, if not among objects themselves, at least among the subjective impressions they leave on the observer, which then unite with memories of other analogous perceptions.

With *The Interpretation of Dreams* (1900a), Freud demonstrated the logical functioning of unconscious thought by elucidating the opposition between "primary process" and "secondary process." Thus causality, the basis for reasoning in conscious thought, is expressed in dreams by means of simple succession, where the main clause is represented by the most developed part of the dream and the dependent clause is represented by the briefest part: "'Because I am of such low descent, the course of my life has been so and so'" (p. 315).

In this essay, Freud asked: "What representations do dreams provide for 'if', 'because', 'just as', 'although', 'either/or', and all the other conjunctions without which we cannot understand sentences or speeches?" He concluded that "dreams have no means at their disposal for



representing these logical relations between the dream-thoughts. For the most part dreams disregard all these conjunctions, and it is only the substantive content of the dream-thoughts that they take over and manipulate. The restoration of the connections which the dream-work has destroyed is a task which has to be performed by the interpretative process" (p. 312).

Freud's thinking suggested, if not a plurality of logics, at least diversity in their modes of representation, and this idea was extended by other authors. Melanie Klein and Wilfred Bion showed how the logic of the infant's fantasies corresponds to relational categories other than that of causality (for example, destructive desire in response to frustration or projective identification). Piera Aulagnier, described categories of the primal (pictogram), the primary (fantasy), and the secondary (idea)—representational modalities impelled by specific logics: the postulate of self-procreation, the all-powerfulness of the desire of the other, and causality, respectively.

In *Les Logiques de l'inconscient* (Logics of the unconscious; 1978), Michel Neyraut reexamined and analyzed the issue of the plurality of logics (primitive, primary, and secondary), thus reinitiating reflection on the opposition between the rational and the irrational.

SOPHIE DE MIJOLLA-MELLOR

*See also:* Pictogram; Primary process/secondary process; Rationalization; Sense/nonsense; Thought; Unconscious fantasy.

### **Bibliography**

Aulagnier, Piera. (2001). *The violence of interpretation: From pictogram to statement* (Alan Sheridan, Trans.). East Sussex, U.K., and Philadelphia: Brunner/Routledge, 2001.

Freud, Sigmund. (1900a). The interpretation of dreams. *SE*, 4–5.

———. (1911b). Formulations on the two principles of mental functioning. *SE*, 12: 213–226.

Neyraut, Michel. (1978). *Les Logiques de l'inconscient*. Paris: Hachette.

---

## **LOOK/GAZE**

"The look," also translated as "the gaze," refers to the activity of intentionally directing one's vision toward

something. It implies the anticipation of an image and a narrowing of the visual field.

With his prior experience with the gaze in hypnosis and with his invention of the analytic couch, Freud showed that he was acutely aware of the important axis that ran from the eye of the analyst to the look of the analysand and of the perceptual asymmetry that resulted from it. He openly declared that he could not bear to spend his entire working day being stared at by the patients he was treating. Contrary to Jean Martin Charcot, he dispensed with the omnipotent look in treatment and even came to consider it a kind of mistake. By characterizing the look as an element of the scopic drive, he opened the way to a series of reflections preserved in his metapsychology, most notably, his study of the voyeur/exhibitionist opposition.

Referring to the "split" between the look and vision, Jacques Lacan, following up on his work with the optical schema of the inverted bouquet as reflected in a mirror, made the look the object of the scopic drive, developing a theory that "most completely eludes the term castration" (Lacan, p. 78). In neurosis, the other's look is most often experienced by the subject with an "uncanny" feeling. In psychosis, the look can amount to persecution leading to a breakdown if it comes to be confused with its source, the eye. And finally, the look, focused on sex, plays an essential role in the genealogy of perversions.

What does "the look" look for? And what is looked at? For Lacan, the phallus is what is looked for, and castration is what is found. The phallic reaction, in the form of erection or a petrified look, is a response to fear of castration. For the subject, the scopic drive is expressed by the appearance or disappearance of the look. From that point on, the subject will use what is supposedly the other's look to construct the fantasy of castration and to make that fantasy seem possible: "I see from only one point," Lacan said, "but in my existence I am looked at from all sides" (1978, p. 72). The myth of Medusa shows that individuals use protective images to try to defend themselves against erection or petrification by the other's look.

Donald Winnicott, in his reflections on why the baby's look turns toward the mother's face, and Françoise Dolto, by insisting that the look plays an important role in symbolizing the difference between boys and girls, both emphasized the structuring role of visual activity. At the beginning of the twenty-first century, psychoanalytic research attempts to draw a

distinction between the drives of seeing and looking. In the treatment of perversions, the field of the look is considered in its relation to speech. The look thus constitutes an organizational schema for the person, as is shown by its overdetermination in various cultures in ways that cut across the fields of the visible and the invisible, such as the “evil eye,” a voracious invidious look.

JEAN-MICHEL HIRT

*See also:* Breastfeeding; Cinema criticism; Face-to-face situation; Fascination; Hypnosis; Identificatory project; Mirror stage; Modesty; Object *a*; Optical schema; Psychoanalytic treatment; Psychogenic blindness; Relaxation psychotherapy; Reversal into the opposite; Self-consciousness; Visual; Visual arts and psychoanalysis; Voyeurism.

### **Bibliography**

- Dolto, Françoise. (1984). *L'image inconsciente du corps*. Paris: Seuil.
- Hirt, Jean-Michel. (1993). *Le miroir du prophète: Psychanalyse et Islam*. Paris: Grasset.
- Lacan, Jacques. (1978). *The seminar of Jacques Lacan. Book 9: The four fundamental concepts of psychoanalysis* (Alan Sheridan, Trans.). New York: W. W. Norton. (Original work published 1964)
- Winnicott, Donald. (1989). Mirror-role of mother and family in child development. In his *Playing and reality*. New York: Routledge.

---

## **LORAND, SÁNDOR (1893–1987)**

Sándor Lorand, a physician, psychoanalyst, and professor of psychiatry, was born on December 2, 1893, in Kassa, Hungary, and died on July 29, 1987, on Long Island, New York.

Born into an Orthodox Jewish family that had been farmers for two generations, Lorand first studied theology, then philosophy (earning a PhD), and finally medicine at the University of Pressburg (now Bratislava), where he earned his medical degree in 1920. The 1918 Budapest psychoanalytic congress impressed him “so much that [he decided] to become a psychoanalyst” (Lorand, 1963). He discovered the writings of Sándor Ferenczi, took the initiative of writing to him to discuss the latter’s theory of hypnotic suggestion, and attended Ferenczi lectures in the medical faculties. While working as a physician attached to the hospital

at Kosice in Czechoslovakia, Lorand arranged in 1921 for Ferenczi to present a paper on “Psychoanalysis for the General Practitioner” to his colleagues. During 1923–24, Lorand was analyzed by Ferenczi and did training work with Paul Federn and Vilma Kovach.

That same year Lorand return to the hospital at Kosice and, following Friedlander in the Netherlands, experimented with a technique for painless childbirth that utilized hypnosis. Despite Ferenczi’s wish that Lorand remain in Czechoslovakia to disseminate psychoanalysis, he decided to emigrate because of the unstable political situation. He settled in New York in 1925 and, with the encouragement of Professor Kirby and Abraham A. Brill, became an American citizen and retook his medical exams. He established a private practice in psychoanalysis and also worked at the Mental Health Clinic of Mount Sinai Hospital. In 1926 he arranged for Ferenczi to lecture at the American Association for Psychoanalysis and at the New School in New York.

Lorand was a training and supervising analyst at the New York Psychoanalytic Institute, where he taught analytical theory and technique to several generations of candidates. He wrote numerous papers, among others on fetishism, nudism, the character of inventors, depressive states, perversions and fairy tales, and liliputian dreams. The range of his writings bears witness to his anthropological and clinical focus, in the tradition of Ferenczi and Géza Róheim. Lorand dedicated *Clinical Studies in Psychoanalysis* (1950) to Ferenczi and edited *Psychoanalysis and Culture* (1951) in honor of Géza Róheim.

MICHELLE MOREAU RICAUD

*See also:* Hungarian School; New York Psychoanalytic Institute.

### **Bibliography**

- Lorand, Sándor. (1946). *Technique of psychoanalytic therapy*. New York: International Universities Press.
- . (1950). *Clinical studies in psychoanalysis*. New York: International Universities Press.
- (ed.). (1951). *The yearbook of psychoanalysis* (Vol. 6). New York: International Universities Press.
- . (1963). Interview with Lawrence Kolb M.D. *Sándor Lorand papers*. Library of Congress: Washington, DC.

Lorand, Sándor, and Schneer, Henry (Eds.). (1961). *Adolescent: Psychoanalytic approach to problems and therapy*. New York: Harper & Brothers.

## LOS ANGELES PSYCHOANALYTIC SOCIETY AND INSTITUTE

Psychoanalysis in Los Angeles enjoyed considerable success after World War II. A fairly large contingent of working analysts, frequently with university and hospital affiliations, had busy practices and widely enjoyed intellectual prestige. On an institutional level, however, West Coast analysis was notable for conflicts that, though largely healed by the 1990s, included splits, internal tensions, and damaging personal rivalries.

The beginnings of psychoanalysis in Los Angeles date to an informal study group in the late 1920s. By the mid-1930s a more formal group had been organized under the aegis of the Chicago Institute for Psychoanalysis, with Ernst Simmel, originally of Vienna, as the first of a number of highly-regarded European analysts who, once in the United States, migrated to California. The arrival of Otto Fenichel, the eminent analyst and prolific author formerly of Berlin, was another key addition; others included May Romm, Frances Deri, and Hannah Heilborn, whom Fenichel eventually married.

The Los Angeles Institute was founded in 1946. Although financial resources were at first strained, with some classes for analysts-in-training held in a nursery school, the institute eventually established itself in Beverly Hills as the profession itself became a highly regarded specialty, with its practitioners much in demand.

From the beginning, however, tensions among members caused strife at the institute, which led to a factional crisis and split in 1950. The reasons for the split seem to have been both personal and ideological, with nonmedical analysts as a major issue. Some of the institute's founding members, including Otto Fenichel, were not against lay analysis, which Freud himself had supported, but others, Martin Grotjahn and May Romm among them, were strongly opposed. This issue, which arose even before the institute was founded, was particularly difficult to resolve, in part because newly arrived European analysts, even if physicians, were compelled, whether by state law or

evolving custom, to retrain in the United States if they wished to be considered doctors. Indeed, Fenichel was undergoing a medical internship when he died unexpectedly in 1946, perhaps from the rigors of hospital work.

The Institute for Psychoanalytic Medicine of Southern California emerged as the breakaway group of medical analysts in the 1950 split, while the Los Angeles Institute retained its name, and both groups affiliated with the American Psychoanalytic Association. The Los Angeles Institute did not programmatically eschew nonmedical analysis and so retained its European-trained contingent. The preponderance of its members were especially insistent on orthodox Freudian theory and technique. By way of contrast, the medical group was strongly influenced by novel ideas in analysis, such as the practice of short-term therapy and "corrective emotional experience," originally promoted by Franz Alexander.

During the 1950s both institutes flourished in the heyday of psychoanalysis in the United States. By the early 1960s, however, the Los Angeles Institute was again riven with internecine strife. A good deal of the tension revolved around the rivalry of two of the institute's most prestigious members, Ralph Greenson and Leo Rangell, each in his way a charismatic figure. Greenson became (like his training analyst Fenichel) the author of a key textbook on psychoanalytic technique; Rangell was also prolific and twice served as president of the American Psychoanalytic Association. Their rivalry was said to have negatively affected the institute's training program.

By the time reorganization of the training program reduced these problems to manageable proportions, the Los Angeles Psychoanalytic Society and Institute, as it was called from 1967, was embroiled in conflicts over the controversial introduction of Kleinian thought into American psychoanalysis. For its part, the American Psychoanalytic Association eschewed the views of Melanie Klein and long ignored the significance of her intellectual successors, such as W. Ronald D. Fairbairn and Donald W. Winnicott, who fruitfully developed object-relations theory. Los Angeles, far from the East Coast centers of psychoanalysis, became for a time a key destination for visits by British Kleinians and object-relations theorists, including Wilfred Bion and Herbert Rosenfield.

Growing enthusiasm for British theorists, particularly at the Los Angeles Psychoanalytic Society and

Institute, led the Kleinians to engage in a bitter fight for acceptance from that organization, amid attacks from within and without. A report by a committee from the American Psychoanalytic Association after a site visit in 1973 accused the institute training program of a variety of faults, an accusation that many viewed as connected to the credibility that some of the analysts at the institute accorded Kleinian thought. In the tumultuous period that followed, a new split threatened, with the Kleinians at one point prepared to go to court. However, issues of both training and theoretical orientation were resolved by the late 1970s and the institute remained unified.

In the 1980s, when psychoanalysis began to lose intellectual ground to biological psychiatry and analysts began competing for patients with practitioners of a welter of new therapies, both institutions adapted to the changing times in a variety of ways. Continued intellectual strife was not absent, but there was also dialogue, tolerance, and movement toward pluralism. The advent of Heinz Kohut's self psychology may have played a role in this process, both by creating conflict and by enabling resolution without the same magnitude of acrimony as in earlier crises.

In contrast with the turbulence at the Los Angeles Psychoanalytic Society and Institute, the Southern California Psychoanalytic Society and Institute, as the breakaway progeny of the 1950 split eventually became called, remained relatively calm for several decades until the influence of self psychology led to strife within the organization in the late 1980s. The Southern California body gave up its insistence on psychoanalysis as a medical specialty, and it actively developed and cultivated a psychoanalytic training program for academics in a variety of fields. In addition, it welcomed Franz Alexander, who moved from Chicago to end his career in California, and was the home organization of Judd Marmor, who served as president of the American Psychiatric Association and, during the 1970s, was influential in deleting homosexuality as a mental disorder in the third edition of the *Diagnostic and Statistical Manual of Mental Disorders (DSM-III)*.

Over the course of several decades, new institutions broadened the base of psychoanalysis in Los Angeles. The Los Angeles Institute and Society for Psychoanalytic Studies, an organization of psychologists and educators, was founded in 1970 and eventually became affiliated with the International Psychoanalytical Association. It offers a training program for mental-health

professionals from a variety of backgrounds. Kleinian analysts, who remained influential in both the Los Angeles Psychoanalytic Society and Institute and the Southern California Psychoanalytic Society and Institute, went on to form the Psychoanalytic Center of California, which joined the International Psychoanalytical Association in 1989. Analysts devoted to self psychology formed the Institute of Contemporary Psychoanalysis in 1990.

As a sign of convergence among analysts on the West Coast, though not without some turmoil and resignations, soon after the turn of the twenty-first century negotiations were begun for a merger between the Los Angeles Psychoanalytic Society and Institute and the Southern California Psychoanalytic Society and Institute. Both institutes are located in the mainstream of psychoanalytic thought, and each is similarly engaged in training psychiatrists as well as postgraduates in the fields of medicine, psychology, social work, marriage and family counseling, law, and the humanities.

JOHN GALBRAITH SIMMONS

### *Bibliography*

- Kirsner, Douglas. (2000). *Unfree associations*. London: Process Press.
- Wilson, Samuel, et al. (Eds.). (1986, December). The "10/40" celebration. *Los Angeles Psychoanalytic Bulletin*, special anniversary issue.

---

## LOST OBJECT

According to Sigmund Freud, the loss of the object is a two-step process whereby the subject is constituted. First, the earliest partial object, the breast, is lost. Then the primary love object, the mother, is likewise lost.

The earliest sexual object is the breast, and the earliest source of satisfaction for the sexual instinct is the encounter between two partial objects, the infant's mouth and the mother's breast. In *Three Essays on the Theory of Sexuality* (1905d), Freud explained that the breast becomes a lost object "just at the time, perhaps, when the child is able to form a total idea of the person to whom the organ that is giving him satisfaction belongs" (p. 222). Loss of the object of the oral instinct is thus a precondition of access to the total person as a

possible love object. At the same time, however, this loss opens the door to autoeroticism for the infant as the infant assumes a complete body image. The infant, though in a passive position, is active with regard to a part of its own body, and this enables the infant to find a source of satisfaction that is the first substitute for the breast.

Later the lost object becomes the “whole person” in the context of the “Fort!/Da!” game described by Freud in *Beyond the Pleasure Principle* (1920g). Here separation from the object is addressed in two ways: either the child expresses an impulse to master the object by breaking it, casting it aside, or incorporating it in fantasy (and so working it over in the psyche), or the child bypasses the need for the object by regarding it as a lost object beyond the reach of the self. With the recognition of the absence of the object, therefore, the child makes a transition, as a result of working over in the psyche, to a capacity to do without the object.

When the subject does not recognize the object as lost, as in melancholia, the object is incorporated in fantasy, where it maintains a silent existence within the subject. Freud described this process in “Mourning and Melancholia” (1916–1917g [1915]). Object loss can also provoke anxiety, mourning, or pain, as Freud outlined in *Inhibitions, Symptoms, and Anxiety* (1926d [1925]).

After Freud, a number of psychoanalysts took up the lost object and developed it in their theories. Melanie Klein described internal objects in “Mourning and Its Relation to Manic-Depressive States” (1935). Jacques Lacan theorized that object *a* is substituted for the lost object. And Nicolas Abraham and Maria Torok related mourning and melancholia to the lost object.

JACQUES SÉDAT

See also: Object.

### **Bibliography**

- Abraham, Nicolas, and Torok, Maria. (1994). *The shell and the kernel: Renewals of psychoanalysis* (Nicholas T. Rand, Trans.). Chicago: University of Chicago Press. (Original work published 1978)
- Freud, Sigmund. (1905d). Three essays on the theory of sexuality. *SE*, 7: 123–243.
- . (1916–1917g [1915]). Mourning and melancholia. *SE*, 14: 237–258.
- . (1920g). Beyond the pleasure principle. *SE*, 18: 1–64.

———. (1926d [1925]). Inhibitions, symptoms, and anxiety. *SE*, 20: 75–172.

Klein, Melanie. (1935). Mourning and its relation to manic-depressive states. *International Journal of Psycho-Analysis*, 21, 125–153.

Lacan, Jacques. (1966). *Écrits*. Paris: Seuil.

### **Further Reading**

Frankiel, Rita V. (Ed.). (1994). *Essential papers on object loss*. New York: New York University Press.

---

## **LOVE**

From a psychoanalytic point of view, love is the investment in, and ability to be loved by, another without experiencing this love as a subjective threat, such as that represented by the Thing (*das Ding*) which Freud described in the Project of 1895. For psychoanalysis the genesis of the love investment must be taken into consideration and the very different modalities through which it manifests itself must be identified.

It is important to differentiate love from infatuation or being in love (*Verliebtheit*), which is associated with a pathological feeling (*Leidenschaft*): “That the state of being in love (*Verliebtheit*) manifests itself abnormally can be explained by the fact that other amorous states outside the analytic cure resemble abnormal rather than normal psychic phenomena” (1915a). Being in love is essentially marked by an overestimation of the love object and a devaluation of the self that resembles the condition of melancholia (1921c).

The genesis of love begins with the oral relation of the infant’s mouth and the mother’s breast: “The picture of the child at the mother’s breast has become the model of all sexual relations” (1905d). Also, in choosing an object later in life, the child will attempt “to reestablish this lost happiness” (1905d). But this happiness, even if it is marked by this choice of a primary infantile object, must later reunite and conjoin two libidinal currents, the tender current arising from infantile cathexis and the sensual current that appears during puberty, “The man will leave his mother and father—as the Bible indicates—and will follow his wife—tenderness and sensuality are therefore reunited” (1912d). This can only occur through the loss of the infantile object choice: “The individual human must devote himself to the difficult task of

separating from his parents,” as Freud indicated in the twenty-first of the *Introductory Lectures on Psychoanalysis* (1916–1917a [1915–16]). Yet, in “On the Universal Tendency to Debasement in the Sphere of Love” (1912d), Freud recalls the difficulty of loving and the numerous splits that remain: “When they love, they do not desire, and when they desire, they cannot love.”

In “Instincts and their Vicissitudes” (1915c), he examines the different splits and oppositions in which love plays a role; these are: loving/hating, loving/being loved, and loving and hating together in opposition to the state of indifference. The pair loving/hating is related to the pleasure/unpleasure polarity; the ego interjects pleasure and expels unpleasure, which is transformed into the opposition ego-pleasure/exterior world-unpleasure. Thus, hatred and the rejection of the exterior world emanate from the narcissistic ego. The pair loving/being loved originates in the reversal of an impulse into its opposite, of activity into passivity, and corresponds to the narcissism of self-love. The pair love/indifference is associated with the polarity ego/exterior world. We love the “object that dispenses pleasure” and we repeat “the original flight before the exterior world” (1926d) in the face of an object that does not dispense pleasure. In this way the intellectual economy of love is profoundly affected by these different forms of ambivalence.

JACQUES SÉDAT

*See also:* Ambivalence; Conflict; Counter-transference; Demand; Direct analysis; Ego-libido/object-libido; Eros; Erotomania; Friendship; Genital love; Gift; Hatred; Homosexuality; *Jalousie amoureuse, La*; Love-Hate-Knowledge (L/H/K bonds); Maternal; Narcissism; Object; Object, change of/choice of; Oedipus complex; Passion; Primary love; Rivalry; Sexuality; Tenderness; Therapeutic alliance; Transference love; Turning around.

### Bibliography

- Freud, Sigmund. (1905d). Three essays on the theory of sexuality. *SE*, 7: 123–243.
- . (1912d). On the universal tendency to debasement in the sphere of love. *SE*, 11: 177–190.
- . (1915a). Observations on transference-love: technique of psycho-analysis. *SE*, 12: 157–171.
- . (1921c). Group psychology and the analysis of the ego. *SE*, 18: 65–143.
- . (1926d). Inhibitions, symptoms and anxiety. *SE*, 20: 75–172.

### Further Reading

- Gabbard, Glen. (1996). *Love and hate in the analytic setting*. Northvale, NJ: Aronson, Inc.
- Kernberg, Otto. (1995). *Love relations. Normality and pathology*. New Haven, CT: Yale University Press.
- Lear, Jonathan. (1990). *Love and its place in nature: A philosophical interpretation of freudian psychoanalysis*. New York: Farrar, Straus & Giroux.

---

## LOVE-HATE-KNOWLEDGE (L/H/K LINKS)

In the 1960s and 1970s Wilfred Ruprecht Bion developed the concept of the link, through three works that appeared in this period: *Learning from Experience* (1962); *Elements of Psycho-Analysis* (1963); and *Transformations* (1965). In these books he described three kinds of links: links of love (L), links of hate (H), and links of knowledge (K)—a model that therefore went beyond the Freudian model of the sexual drives of love (with their uniting function) and the sexual drives of hate (with their dividing function).

These concepts were particularly developed in chapters 14 and 27 of *Learning from Experience* and chapter 6 of *Transformations*.

“The feelings we know by the names ‘love’ and ‘hate’ would seem to be obvious choices if the criterion is basic emotion. Envy and Gratitude, Depression, Guilt, Anxiety, all occupy a dominant place in psychoanalytic theory and would seem with Sex to be choices to place with love and hate. In fact I prefer three factors I regard as intrinsic to the link between objects considered to be in relationship with each other. An emotional experience cannot be conceived of in isolation from a relationship. The basic relationships that I postulate are (1) X loves Y; (2) X hates Y; and (3) X knows Y” (1962, pp. 42–43) In reality, according to Cléopâtre Athanassiou: “W. R. Bion not only opposes the formation of links to whatever breaks them apart; he opposes them with another kind of union, the agglomeration, group formation par excellence.” She adds: “The basic elements of a person can be transformed through the intervention of another person. This encounter leads to a modification in the way the (psychic) elements are linked together: instead of forming agglomerations, they will form veritable bonds of such a sort that the rigid screen presently secretes a more supple matter, to take its place, capable

of allowing passage from one side of the (contact) barrier to the other” (1997).

In other words, the links are formed dynamically at the very heart of the primitive interrelationship. On that basis, Wilfred Bion describes the three links of love, hatred, and knowledge and he makes of these links working tools allowing the easy understanding of the content of a session: “Meaning is a function of self-love, self-hate or self-knowledge” (1965, p. 73).

It is on the basis therefore of a search for the “key” to a session, and of a reflection on the theory of interpretation, that Bion clarifies and deepens the nature of these three types of links. He remains insistent on the fact, fundamental in his eyes, that there is no knowledge of the object that is not, first of all, deeply rooted in emotional ties. The discovery of the object proceeds fundamentally by feeling, which, in itself, is already a kind of encounter with and knowledge of the object—an idea which Donald Meltzer developed later, through his concept of “aesthetic conflict.” For Bion, in effect, all emotional experience is a link, because it puts a Self and object in the presence of each other.

The L, H, and K links are proper to life and indissoluble from the mechanism of projective identification. Recall that for Melanie Klein the object of projection is not only matter for an expulsion of whatever has become undesirable in oneself, but enters in fact into a veritable relation with oneself on the basis of only the external expression of an internal link. The object finds itself thereby invested by a link of love, hatred, or knowledge, in direct rapport with the kind of link the subject entertains with its internal objects.

Ultimately, Bion describes equal, but negative ties for each of the three links: –L, –H, and –K, specifying that –L is not the equivalent of H (“not to love” is not “to hate”), –H does not equal L (“not to hate” is not “to love”) and that –K, or an aptitude for misunderstanding, is sometimes superior to understanding. “The relationship of K to –K can be epitomized by saying that in K particularization and concretization of the abstract and general is possible, but in –K it is not because the abstract and general, in so far as they exist, are felt to become things-in-themselves” (1962, p. 98). It is considered that the links K and –K testify in their manner to the Kantian influence in Bion on the concept of the thing-in-itself.

BERNARD GOLSE

See also: Emotion; *Learning from Experience*; Transformations; Vertex.

### Bibliography

- Athanassiou, Cléopâtre. (1997). *Bion et la Naissance de l'espace psychique*. Paris: Popesco.
- Bion, Wilfred R. (1962). *Learning from Experience*. New York: Basic Books.
- . (1963). *Elements of Psychoanalysis*. London: Heinemann.
- . (1965). *Transformations: Change from learning to growth*. London: Heinemann.
- Meltzer, Donald. (1988). Le Conflit esthétique: son rôle dans le processus de développement psychique. *Psychanalyse à l'Université*, 13 (49), 37–57.

### Further Reading

- Gabbard, Glen. (1996). *Love and hate in the analytic setting*. Northvale, NJ: Aronson, Inc.
- Kernberg, Otto. (1995). *Love relations: Normality and pathology*. New Haven, CT: Yale University Press.
- Lear, Jonathan. (1990). *Love and its place in nature: A philosophical interpretation of freudian psychoanalysis*. New York: Farrar, Straus & Giroux.

---

## LOW, BARBARA (1877–1955)

Barbara Low, a British psychoanalyst, was born in 1877 in London, where she died on December 25, 1955. She was the youngest daughter of eleven children in an Anglo-Jewish family with Austrian and Hungarian parents. Several members of the family distinguished themselves in various walks of life. After attending a pioneering girls' school in London, she gained her degree at University College before training as a teacher. She taught for several years at girls' schools, and during the First World War taught at Hackney Downs School for boys. For some years she lectured on education, history, and literature at the London County Council Training College for Teachers at Fulham. She joined the Labour Party and worked actively on its behalf. She was also active in the Fabian Society, joining soon after its formation with Herbert G. Wells, Bernard Shaw, and D. H. Lawrence, the last

of whom she had a warm correspondence with, reflecting her wide culture.

Low was introduced to psychoanalysis by Dr. David Eder, who had married her sister Florence (to whom she was closely attached). She gave up her career as a teacher to study psychoanalysis and went to Berlin for analysis with Hans Sachs (as did Sylvia Payne and Ella Sharpe). She was impressed by the polyclinic in Berlin and urged setting up a similar organization in London.

While maintaining her wide interests, Low devoted the rest of her life to psychoanalysis. In 1919 she was a founding member of the British Psycho-Analytical Society, and until the arrival of Melanie Klein, she and Eder were the only Jewish members. She brought her lively mind, clarity of thought, and didactic skills to bear on her new profession. In 1920 she wrote *Psycho-Analysis: A Brief Account of the Freudian Theory*, a book that ran to several editions. She wrote a number of important papers, including a number that dealt with unconscious factors in education, and she conceived the Nirvana Principle, which Freud approved of and acknowledged in his writings. She was an active member of the Institute for the Study and Treatment of Delinquency, which she served both as lecturer and therapist.

Low was an active discussant in international meetings and contributed to the intellectual and scientific life of the British Psycho-Analytical Society. She served as its librarian and as a member of the Public Lectures Committee. She also served as director of Imago Publishing Company on its foundation. She always fought vigorously for her beliefs, as was particularly evident in the controversial discussions between Anna Freud and Melanie Klein between 1941 and 1945 (King & Steiner, 1991). She was a staunch supporter of Edward Glover and Anna Freud in these debates, putting forward several proposals for discussion and attending all of the meetings until Glover's resignation from the society in 1944.

Though her health was good during her last two years, she was forced into semiretirement. Dr. Eder predeceased her, and she shared a home with her sister. There she died peacefully in her sleep at the age of seventy-eight on Christmas morning, 1955.

CLIFFORD YORKE

*Notion developed:* Nirvana.

*See also:* Death instinct (Thanatos); Discharge; Great Britain; Imago Publishing Company; Pleasure/unpleasure principle.

### **Bibliography**

- King, Pearl, and Steiner, Riccardo. (1991). *The Freud-Klein controversies, 1941–45*. London: Tavistock Publications, Routledge.
- Low, Barbara. (1924). Psycho-analysis and education. In Ernest Jones (Ed.), *Social aspects of psycho-analysis*. London: Williams & Norgate.
- . (1925). The foundations of mental health. *International Journal of Psycho-Analysis*, 7.
- . (1927). An interesting invented “portmanteau” word. *International Journal of Psycho-Analysis*, 8, 73–74.
- . (1929). A note on the influence of psycho-analysis upon English education during the last 18 years. *International Journal of Psycho-Analysis*, 10, 314–320.

---

## **LUCY R., CASE OF**

“Miss Lucy R.” is the second case study presented by Freud in *Studies on Hysteria* (1895d). Lucy was a British governess whom he treated for nine weeks, beginning in December 1882.

Thirty years old, she was being treated by a colleague of Freud's for chronically recurrent suppurative rhinitis. This young English woman of delicate constitution was a governess for the managing director of a factory in the Vienna suburbs. She had recently lost the ability to smell and suffered from depression accompanied by olfactory hallucinations of the smell of “burnt pudding,” which Freud immediately identified as the origin of her hysteria.

“I therefore decided to make the smell of burnt pudding the starting point of the analysis,” Freud wrote (1895d, p. 107). But the treatment, which should have been short, turned out to be more difficult than expected because the patient, who was working, was unable to see him outside his consulting hours. As a result, he could only devote a few moments of time to her, unlike those patients who were able to make appointments in advance. “We used therefore to break our conversation off short and take up the thread at the same place next time. Miss Lucy R. did not fall into a state of somnambulism when I tried to hypnotize her. I therefore did



without somnambulism and conducted her whole analysis while she was in a state which may in fact have differed very little from her normal one” (p. 107).

In his description of Lucy’s case, Freud, for the first time, provides a detailed explanation of his new procedure. “When, therefore, my first attempt did not lead either to somnambulism or to a degree of hypnosis involving marked physical changes, I ostensibly dropped hypnosis, and asked only for ‘concentration’; and I ordered the patient to lie down and deliberately shut her eyes as a means of achieving this ‘concentration.’ . . . I decided to start from the assumption that my patients knew everything that was of any pathogenic significance and that it was only a question of obliging them to communicate it” (pp. 109–10). To force this response, “I placed my hand on the patient’s forehead or took her head between my hands and said, ‘You will think of it under the pressure of my hand. At the moment at which I relax my pressure you will see something in front of you or something will come into your head. Catch hold of it. It will be what we are looking for.—Well, what have you seen or what has occurred to you?’” (p. 110). This procedure, he added, “has scarcely ever left me in the lurch” (p. 111), and all Freud had to do was to tell his patients that it was impossible to fail to extract information from them.

Freud helped Lucy realize that she was in love with the widower whose children she cared for. After his prescribed hydrotherapy treatments failed to have an effect, he was astonished to see her return after the Christmas holidays without any real improvement. Moreover, the smell of burned pudding associated with her hidden love for her employer had been replaced by the smell of cigar smoke.

Freud again applied pressure to her forehead with his hands. Another scene materialized where her

employer had scolded her violently for having allowed a female visitor to kiss his children. This scene indicated that she realized he did not love her, and was associated with another scene, this time of the conclusion of a meal and the presence of cigar smoke. This realization resulted in her complete recovery, probably near the end of January 1893.

Freud saw Lucy again in June 1893, when she was in perfect health. He never questioned himself about the cigar smoke. Cigar smoke came up again during Freud’s treatment of Dora, for none of his patients was likely to overlook his passion for cigars. Nothing like a transference neurosis can be found in Freud’s descriptions of these early treatments, which have little in common with later psychoanalytic therapy. Nonetheless, they are important, aside from the interest in Freud’s activity as a therapist, for what they teach us about his theoretical development. With Miss Lucy R., Freud abandoned hypnosis and became certain that his patients possessed an intimate but repressed knowledge of their symptoms. He thus recognized the importance of the means used to overcome patients’ resistance to remembering.

ALAIN DE MIJOLLA

*See also:* Multilingualism and psychoanalysis; Resistance; *Studies on Hysteria*.

### **Bibliography**

- Freud, Sigmund, and Breuer, Josef. (1895d). Studies on hysteria. *SE*, 2: 48–106.
- Ellenberger, Henri F. (1970). *The discovery of the unconscious: The history and evolution of dynamic psychiatry*. New York: Basic.



**one:** Muriel M. Gardiner (1901–1985), American psychoanalyst and psychiatrist. Gardiner's work was notable for the fact that she took psychoanalysis out of private practice into schools, prisons, and hospitals. *Public Domain. Courtesy of the New York Psychoanalytic Institute and Society.* **two:** Elisabeth Geleerd (1909–1969), Dutch psychoanalyst. Geleerd was instrumental in developing the child and adolescent analysis programs at the New York Psychoanalytic Institute. *Courtesy of the New York Psychoanalytic Institute and Society. Reproduced by permission.* **three:** Edward Glover (1888–1972), British psychoanalyst and physician. Glover's interest in criminal behavior and juvenile delinquency led him to found the Institute for the Study and Treatment of Delinquency and *The British Journal of Delinquency*. Glover left the British Psycho-Analytical Society after the fallout of the Controversial Discussions between Melanie Klein and Anna Freud. *Photo courtesy of The Psychoanalytic Quarterly who published it in 1973, Volume 42, Number 2. Reproduced by permission.*



**four:** Wladimir Granoff (1924–2000), French psychiatrist and psychoanalyst. Granoff was one of the founders of the Association Psychanalytique de France (French Psychoanalytic Association). *Courtesy of the International Association for the History of Psychoanalysis. Reproduced by permission.* **five:** Phyllis Greenacre (1894–1989), American physician and psychoanalyst. Greenacre is known for her work in the areas of fetishism and creativity. *Courtesy of the New York Psychoanalytic Institute and Society. Reproduced by permission.* **six:** Georg Groddeck (1866–1934), German physician and psychoanalyst. Groddeck's *The Book of the It* was influential on Freud's development of the concept of the "Id." *Public Domain. Courtesy of the New York Psychoanalytic Institute and Society.* **seven:** Eduard Hitschmann (1871–1957), Austrian physician and psychoanalyst. Hitschmann served as the Freud family doctor briefly. *Public Domain. Courtesy of the New York Psychoanalytic Institute and Society.*





8



9

**eight:** Willi Hoffer (1897–1967), British physician and psychoanalyst. Elected Honorary Vice-President for Life by the International Psychoanalytical Association, Hoffer was primarily interested in what could be learned from the study of children. *Photograph of Willi Hoffer, Int. J. Psycho-Anal. (1969), 50: 260. © Institute of Psychoanalysis, London, UK. Reproduced by permission.* **nine:** Karen Danielson Horney (1885–1952), German-born psychiatrist and psychoanalyst. Horney was one of the founding members of the Association for the Advancement of Psychoanalysis, after the split from the New York Psychoanalytic Institute and Society. © *Corbis. Reproduced by permission.* **ten:** Advertisement for the psychoanalytic journal *Imago*. *Mary Evans Picture Library. Reproduced by permission.*

10

## Imago

**Zeitschrift für Anwendung der Psychoanalyse  
auf die Natur- und Geisteswissenschaften**

Herausgegeben von

**Sigm. Freud**

Redigiert von Sándor Radó, Hanns Sachs, A. J. Storfer

Jährlich 4 Hefte Großquart im Gesamtumfang von  
etwa 560 Seiten. Abonnement jährlich M. 22.—

*Im Januar 1932 beginnt der XVIII. Jahrgang*

INTERNATIONALE ZEITSCHRIFT  
FÜR  
ÄRZTLICHE PSYCHOANALYSE

OFFIZIELLES ORGAN  
DER  
INTERNATIONALEN PSYCHOANALYTISCHEN VEREINIGUNG

HERAUSGEGEBEN VON  
PROF. DR. SIGM. FREUD

REDIGIERT VON  
DR. S. FERENCZI      DR. OTTO RANK  
BUDAPEST              WIEN

PROF. DR. ERNEST JONES  
LONDON

UNTER STÄNDIGER MITWIRKUNG VON:

DR. KARL ABRAHAM, BERLIN. — DR. LUDWIG BINSWANGER, KREUZLINGEN. —  
DR. POUL BJERRE, STOCKHOLM. — DR. A. A. BRILL, NEW-YORK. — DR. TRIGANT  
BURROW, BALTIMORE. — DR. M. D. EDER, LONDON. — DR. J. VAN EMDEN, HAAG. —  
DR. M. EITINGON, BERLIN. — DR. PAUL FEDERN, WIEN. — DR. EDUARD HITSCHMANN,  
WIEN. — DR. L. JEKELS, WIEN. — DOZ. C. G. JUNG, ZÜRICH. — DR. FRIEDR. S. KRAUSS,  
WIEN. — DR. ALPHONSE MAEDER, ZÜRICH. — DR. J. MARCINOWSKI, SIELECK.  
— PROF. MORICHAU-BEAUCHANT, POTTERS. — DR. OSKAR PFISTER, ZÜRICH. — PROF.  
JAMES J. PUTNAM, BOSTON. — DR. R. REITLER, WIEN. — DR. FRANZ RIKLIN, ZÜRICH.  
— DR. HANNS SACHS, WIEN. — DR. J. SADGER, WIEN. — DR. L. SEIF, MÜNCHEN. —  
DR. A. STÄRCKE, HOEFTER-HEIDE. — DR. A. STEGMANN, DRESDEN. — DR. M. WULFF, ODESSA.

I. JAHRGANG, 1913  
HEFT 5. SEPTEMBER



1913

HUGO HELLER & CIE.  
LEIPZIG UND WIEN, I. BAUERNMARKT 3

11

JÄHRLICH 6 HEFTE BEI 40 BOGEN STARK M 18.— = K 21.60

Die „Internationale Zeitschrift für ärztliche Psychoanalyse“ stellt sich die Aufgabe, dem Anfänger durch didaktische Aufsätze eine Einführung in das Wesen und die Übung der Psychoanalyse zu geben, den Vorgesrittenen Gelegenheit zum Austausch ihrer Erfahrungen zu bieten und sie durch Kritiken und Referate fortlaufend von der Entwicklung dieser jungen Wissenschaft zu unterrichten.

Die Zeitschrift bringt Originalarbeiten zum Abdruck, von denen eine Erweiterung unserer psychoanalytischen Erkenntnisse zu erwarten ist, und Mitteilungen, durch welche die bekannten Lehren erläutert und bestätigt werden sollen.

Es erscheinen jährlich sechs Hefte der Zeitschrift, jeden zweiten Monat abwechselnd mit „Imago“, im Gesamumfang von ca. 36—40 Druckbogen zum Jahrespreis von M 18.— = K 21.60.

Auch wird ein gemeinsames Abonnement auf die beiden psychoanalytischen Zeitschriften zum ermäßigten Gesamtjahrespreis von M 30.— = K 36.— eröffnet.

Das rege Interesse, das insbesondere Amerika und England an der Entwicklung und Ausbreitung der psychoanalytischen Lehren nehmen, läßt einen engeren Kontakt mit den Forschern und Ärzten dieser Länder wünschenswert erscheinen. Die Zeitschrift wird von nun an diesem Zwecke der psychoanalytischen Literatur besondere Aufmerksamkeit widmen und hat sich zur Förderung dieses Zweckes die redaktionelle Mitwirkung ihres geschätzten Mitarbeiters Dr. Ernest Jones in London, Professors der Psychiatrie an der Universität in Toronto, gesichert.

12

Für die Redaktion bestimmte Zuschriften und Sendungen an:

Dr. S. Ferenczi, Budapest, VII. Elisabethring 54.

All American and English communications and contributions should be sent (typewritten) to Dr. Ernest Jones, 69 Portland Court, London W.

Alle Manuskripte sind vollkommen druckfertig einzusenden.

Sämtliche Beiträge werden mit dem einheitlichen Satz von K 50.— pro Druckbogen honoriert.

Von den „Originalarbeiten“ und „Mitteilungen“ erhalten die Mitarbeiter je 50 Separatabzüge gratis geliefert.

Copyright 1913. Hugo Heller & Cie., Wien, I. Bauernm. 3.

**eleven:** Cover of the first issue (September 1913) of the *Internationale Zeitschrift für Ärztliche Psychoanalyse* (International Review of Medical Psychoanalysis). *Public Domain. Courtesy of the New York Psychoanalytic Institute and Library.*

**twelve:** Inside front cover of the *Internationale Zeitschrift für Ärztliche Psychoanalyse* (International Review of Medical Psychoanalysis), Sept. 15, 1913. *Public Domain. Courtesy of the New York Psychoanalytic Institute and Society.*

**thirteen:** Edith Jacobson (1897–1978), German psychoanalyst and physician. Jacobson was the first to comprehensively integrate drive theory with structural and object relations theory. *Courtesy of the New York Psychoanalytic Institute and Society. Reproduced by permission.*



13



14



15

**fourteen:** Ludwig Jekels (1867–1954), Austrian psychiatrist. Jekels translated Freud's works into Polish and introduced psychoanalysis in Poland. *Courtesy of the New York Psychoanalytic Institute and Society. Reproduced by permission.* **fifteen:** Smith Ely Jelliffe (1866–1945), American psychiatrist and one of the founders of *The Psychoanalytic Review*. *Photo courtesy of The Psychoanalytic Quarterly who published it in 1946, Volume 15, Number 1. Reproduced by permission.* **sixteen:** Ernest Jones (1879–1958), British psychoanalyst and founder of the British Psycho-Analytical Society. *Photo by Bertl Sachsels. Courtesy of the New York Psychoanalytic Institute and Society. Reproduced by permission.* **seventeen:** Carl Jung (1875–1961), Swiss psychiatrist. One of Freud's first and closest followers, Jung split from Freud and created a new type of psychotherapy—Analytical Psychology. *The Library of Congress. Reproduced by permission.*

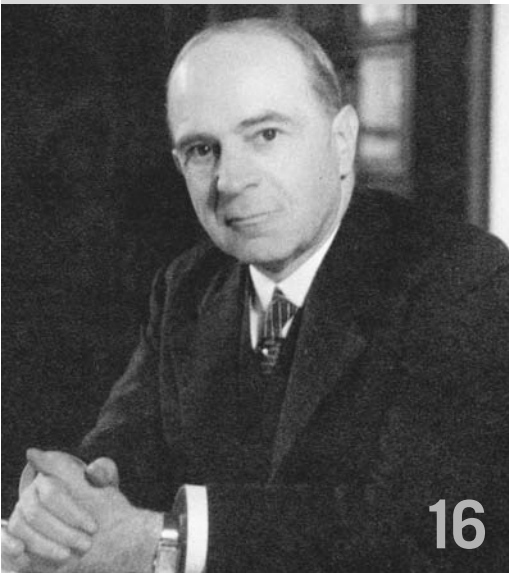

16



17

18



19



**eighteen:** Ernst Kris (1900–1957), Austrian/American psychoanalyst and art historian. A member of the New York Psychoanalytic Society until his death, Kris co-founded the journal *The Psychoanalytic Study of the Child* with Anna Freud and Marie Bonaparte. *Courtesy of the New York Psychoanalytic Institute and Society. Reproduced by permission.* **nineteen:** Marianne Kris-Rie (1900–1980), Austrian psychoanalyst. Kris-Rie was a founder of the Association for Child Analysis and served as the Association's first president. *Courtesy of the New York Psychoanalytic Institute and Society. Reproduced by permission.* **twenty:** Jacques Lacan (1901–1981), French psychiatrist and psychoanalyst. Lacan gave weekly *Seminars*, and founded L'École freudienne de Paris, a psychoanalytic study group. © Jerry Bauer. *Reproduced by permission.* **twenty-one:** René Laforgue (1894–1962), French psychiatrist and psychoanalyst. Laforgue was the first president of the Société psychanalytique de Paris (Paris Psychoanalytic Society). *Public Domain. Courtesy of the New York Psychoanalytic Institute and Society. Reproduced by permission.*



20



21



22



23



24



25

**twenty-two:** Philip Lehrman (1895–1958), Russian psychiatrist and psychoanalyst. Lehrman was an amateur filmmaker whose films of Freud and his colleagues at work have provided invaluable documentation of the history of psychoanalysis. *Courtesy of the New York Psychoanalytic Institute and Society. Reproduced by permission.* **twenty-three:** Adam Limentani (1913–1994), British psychoanalyst and psychiatrist. Limentani served as president of both the British Psycho-Analytical Society and the International Psychoanalytical Association. *Courtesy of the International Association for the History of Psychoanalysis. Reproduced by permission.* **twenty-four:** Rudolph Loewenstein (1898–1976), Polish-born physician and psychoanalyst. Loewenstein was instrumental in the creation of both the Paris Psychoanalytic Society and the *Revue française de psychanalyse*. He is most well known, however, for being the cofounder of the new American school of psychoanalysis in the 1950s and his work in ego psychology. *Courtesy of Dr. Richard Loewenstein and JAPA. Reproduced by permission.* **twenty-five:** Margaret S. Mahler (1897–1985), Hungarian pediatrician and psychoanalyst. Mahler was chair of the child analysis program at the Philadelphia Psychoanalytic Institute. Her work with children led to the development of her separation-individuation theory. *Courtesy of the New York Psychoanalytic Institute and Society. Reproduced by permission.*





26

**twenty-six:** Karl Menninger (1893–1990), American psychiatrist and author. Co-founder of the Menninger Clinic with his father and brother, Menninger introduced many European analysts to the United States and his book *The Human Mind* explained psychoanalytic theory to the general public. *AP/Wide World Photos. Reproduced by permission.* **twenty-seven:** Adolf Meyer (1866–1950), psychiatrist and one of the founders of the New York Psychoanalytic Society and the American Psychoanalytic Association. *The Alan Mason Chesney Medical Archives of The Johns Hopkins Medical Institutions. Reproduced by permission.* **twenty-eight:** Herman Nunberg (1884–1970), physician and psychoanalyst. Together with Ernst Federn, Nunberg compiled the minutes of the Vienna Psychoanalytic Society (published 1967–1972). © *Institute of Psychoanalysis, London, UK. Reproduced by permission.*

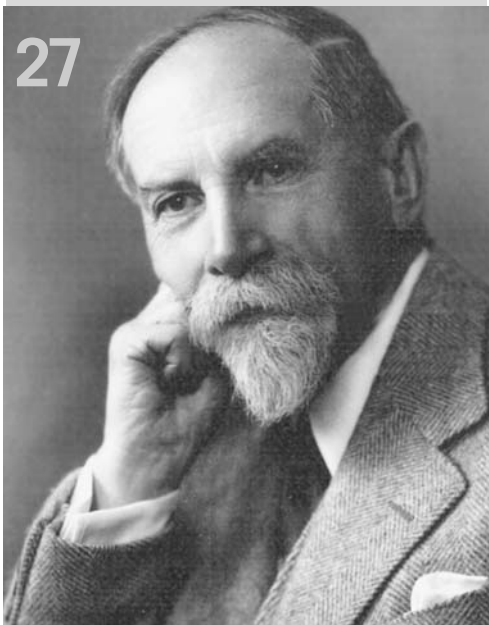

27

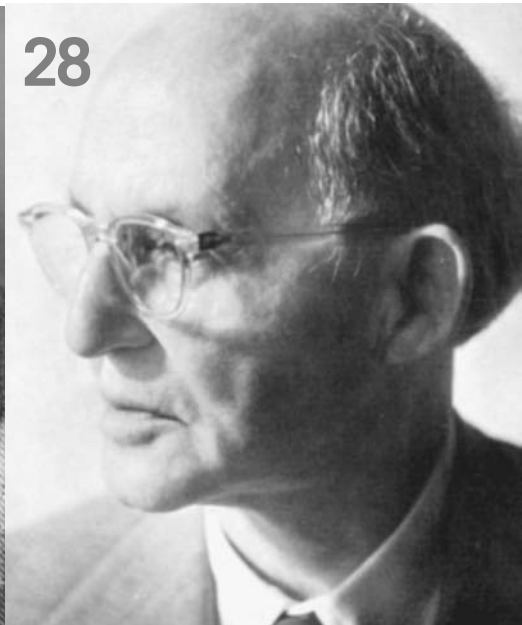

28

# M W

## MAEDER, ALPHONSE E. (1882–1971)

Alphonse Maeder, a physician specializing in psychiatry and psychotherapy, was born in La Chaux-de-Fonds, Switzerland on September 11, 1882, and died in Zürich on January 27, 1971.

The bilingual son of a Swiss German watchmaker, he began to study medicine at Berne in 1901 and continued his studies in Zürich and Berlin. In 1903 he made the acquaintance of the zoologist and philosopher Hans Driesch, who had already integrated Aristotelian entelechy into his neo-vitalist philosophy.

From 1906 to 1910 Maeder worked in Zürich as assistant physician to Eugen Bleuler and Carl Gustav Jung, who introduced him to psychoanalysis. He attended the 1910 Nuremberg congress.

From 1911 to 1918 he worked as a therapist in Dr. Bircher-Benner's sanatorium before opening a private practice as a psychotherapist in Zürich, where he worked almost until his death.

Beginning in 1906, he published psychoanalytic works in German: *Die Sexualität der Epileptiker* (The sexuality of epileptics; 1909), *Psychologie der Schizophrenen* (The psychology of schizophrenics; 1910), as well as articles on the symbolism of dreams, whose origin he linked to projection: *Zur Entstehung der Symbolik im Traum* (On the formation of symbols in dreams; 1910–1911) and the function of dreams: *Funktion des Traumes* (The function of dreams, 1912). He stressed the “prospective capacity of the soul” in the sense of Hans Driesch's entelechy.

Freud had great respect for Maeder and put him in charge of relations with French-speaking colleagues.

However, when Maeder formulated an hypothesis in 1912 concerning the prospective capacity of dreams, Freud severely criticized him (much to Maeder's surprise) and warned him against mystical tendencies.

Following that episode, Maeder broke with Freud at the same time as Jung and henceforth continued to seek his own path. His approach gave priority to the self-regulating and self-healing capacities of the soul, the “personal association” between the physician and the patient, and the role of the physician as “healer,” as “the one who reconstitutes globality.” This idea of “synthesis” led him to Martin Buber's circle and, in 1932, to collaborating with Frank Buchmann's Oxford Group. In 1957 he published a text on his spiritual development and his memories of Freud.

KASPAR WEBER

See also: *Année psychologique*, L'; *Archives de psychologie*, Les; Switzerland (German-speaking).

### Bibliography

- Maeder, Alphonse. (1909). Die Sexualität der Epileptiker. *Jahrbuch für psychoanalytische und psychopathologische Forschungen*, 1, 119–154.
- . (1910). Psychologische Untersuchungen an Dementia præcox-Kranken. *Jahrbuch für psychoanalytische und psychopathologische Forschungen*, 2 (1), 185–245.
- . (1910). Zur Entstehung der Symbolik im Traum, in der Dementia præcox, usw. *Zentralblatt für Psychoanalyse*, 1, 383–389.
- . (1912). Über die Funktion des Traumes (mit Berücksichtigung der Tagesträume, des Spieles, usw.). *Jahrbuch für psychoanalytische und psychopathologische Forschungen*, 4.

———. (1957). *Der Psychotherapeut als Partner. Eine appellative Psychotherapie*. Zürich-Stuttgart: Rascher.

## MAGICAL THINKING

Magic is the technique associated with an animist conception of the world. It seeks to impose on objects in the external world laws that are part of mental life and, more generally, to subject natural phenomena to human will. The magical practices of primitive peoples are compared by Freud to children's play, art, and neurosis.

In chapter three of *Totem and Taboo* (1912–1913a), Freud develops his ideas about magic and a modality of thought—“magical thought”—that he compares to the omnipotence of ideas. His remarks are taken directly from his reading of sociologists and anthropologists like Marcel Mauss, Salomon Reinach, Sir Edward Tylor, and Sir James Frazer. They reflect not only the utility of such ideas for psychoanalysis and psychopathology (obsessional neurosis, paranoia) but also the modifications that the psychoanalytic approach can provide to our understanding of the concept of magic. Returning to an idea already introduced concerning the epistemophilic drive in children, Freud stresses the fact that the practical need to subjugate the world together with simple speculative curiosity pushed humans to create their first cosmic systems.

Freud identifies sorcery as a tool to influence “spirits” by treating them as one would human beings, that is by appeasing and subjugating them through magic. Magic, which is more primitive, corresponds to a preanimist phase when nature is alive and spiritualization has not yet been concentrated in “spirits.” Referring to Frazer, Freud distinguishes between imitative, or homeopathic, magic, which produces the desired phenomenon by carrying out a similar action with symbolic value, and “contagious” magic, whose efficacy is not tied to any similarity but temporal contiguity. However, regardless of the form magic assumes, it always satisfies the same need—human desire—and expresses mankind's overconfidence in the omnipotence of his desires and his ideas. Narcissism (1912–1913a) is the cause of this excessive confidence that the primitive and the neurotic attribute to mental activities, which is the foundation of magical practices and neurotic symptoms that simultaneously strive to counteract and to grant the bad wish, which is in fact the desire for death.

According to Freud, magic is situated within a preanimist system: “Whereas magic still reserves omnipotence solely for thoughts, animism hands some of it over to spirits and so prepares the way for the construction of a religion” (p. 95). The distinction between these two systems is associated with the affective conflict that death leaves with the survivors, leading them to create spirits through projection. In this sense magic can be seen to belong to a narcissistic system, while animism implies, with the recognition of the inevitability of death, the initial recognition of *ananke*.

Géza Róheim (1950) created a body of work based on the use of psychoanalysis as an explanatory instrument in anthropology, in contrast to the customary procedure of limiting anthropological explanation to a single culture, or even a single tribe. His research has provided considerable insight into magical thought in this field, as has the work of Georges Devereux.

SOPHIE DE MIJOLLA-MELLOR

*See also:* Animistic thought; Archaic; Leuba, John; Mythology and psychoanalysis; Omnipotence of thought; Primitive; Taboo; Thoughts; Undoing.

### Bibliography

- Freud, Sigmund. (1912–1913a). Totem and taboo. *SE*, 13: 1–161.
- Róheim, Géza. (1930). *Animism, magic, and the divine king*. London: K. Paul, Trench, Trubner & Co., Ltd.
- . (1950). *Psychoanalysis and anthropology; Culture, personality and the unconscious*. New York: International Universities Press.

## MAHLER, GUSTAV (MEETING WITH SIGMUND FREUD)

During the summer of 1910, when Freud was vacationing with his family on the North Sea in the Netherlands, Gustav Mahler, in a state of deep depression, decided to consult him. The neurologist Richard Nepallek, a relative of Alma Mahler, was the go-between. The composer's “maddening doubt” led him to put off the meeting on three successive occasions. August 26 was the last day it was possible to meet Freud, since he was getting ready to travel to Sicily together with Sándor Ferenczi.

The meeting took place in a restaurant in Leyden. For four hours there took place a “psychoanalytic session,” along the canals of the city where the two men walked. That summer of 1910 Mahler had experienced a personal drama: He feared his wife would leave him and became aware that his life had become that of a neurotic.

In a letter to Theodor Reik, written in 1934, Freud noted Mahler’s “brilliant faculty of comprehension.” This unique psychoanalytic session allowed him to discover the musician’s Marian complex (mother fixation), but “no light was shed on the symptomatic façade of his obsessive neurosis.” Freud continued, “If I can believe what I have heard, I have done good work.” Mahler, for his part, wrote in a telegram he sent to Alma the day after the meeting, “I’m filled with joy. Interesting conversation. . . .” He died May 18, 1911, nine months later.

DOMINIQUE BLIN

*See also:* Music and psychoanalysis; Reik, Theodor; Walter, Bruno.

### **Bibliography**

Jones, Ernest. (1953–1957) *Sigmund Freud: Life and work*. London: Hogarth Press.

Kuehn, John L. (1965) Encounter at Leyden: Gustav Mahler consults Sigmund Freud. *Psychoanalytic Review*, 52, 345–364.

La Grange, Henry-Louis de (1973) *Gustav Mahler, Vol 3: Le génie Foudroyé, 1907–1911*. Paris: Fayard.

Reik, Theodor. (1953). *The haunting melody: Psychoanalytic experiences in life and music*. New York: Farrar, Straus and Young

## **MAHLER-SCHÖNBERGER, MARGARET (1897–1985)**

The psychoanalyst Margaret Schönberger Mahler was born in the old Hungarian city of Sopron on May 10, 1897. She died in New York on October 2, 1985.

The Schönbergers were a wealthy and intellectual Jewish family. Mahler’s father, Gustav, was a general practitioner to whom she was close; but her relationship with her mother, Eugenia, was distant and conflicted. While still attending the gymnasium, she first encountered psychoanalysis when she met Sándor

Ferenczi, who greatly impressed her. She entered medical school at the University of Budapest in 1917, moved to Germany two years later, studied pediatrics and graduated magna cum laude from the University of Jena in 1922. She settled in Vienna where, because she had opted for Austrian citizenship in the wake of World War I, she could practice medicine.

Mahler’s interest in psychiatry and psychoanalysis developed as she turned away from the unempathic, sterile practice of pediatrics then common in the Austrian clinic where she worked. She met August Aichhorn and Karl Abraham, attended Anna Freud’s child analysis seminar, and in 1926 applied to the Vienna Psychoanalytic Institute and underwent a training analysis (Stepansky, 1988). Her first analysis, with Helene Deutsch, disappointed her; she subsequently was analyzed by Aichhorn, with whom she had a love affair; her final analysis with Willi Hoffer, from 1930 to 1935, was more successful. She was finally certified as an analyst, after various difficulties, in 1933. In 1936 she married Paul Mahler, Ph.D., a chemist.

With the approach of the Second World War—her mother would die in a concentration camp—Mahler moved briefly to Britain before emigrating to the United States in 1938. The next year, settled in New York, she set up private practice as an analyst and became a member of the New York Psychoanalytic Society. In 1945 she once more entered analysis, with Edith Jacobson.

Mahler assumed various responsibilities at the New York State Psychiatric Institute, affiliated with Columbia University, before becoming professor of psychiatry at the Albert Einstein College of Medicine in 1950. She also became chair of the child analysis training program at the Philadelphia Psychoanalytic Institute and, importantly for her observational studies, she directed research at the Master’s Children Center in New York.

Mahler’s early publications, dating to the late 1940s, concerned tic disorders. Her work with severely ill young children led to prognostic considerations in cases of child psychosis, then a controversial diagnosis. In 1952 she suggested a “symbiotic” syndrome, to be distinguished from autistic psychosis on the basis of “a fixation at, or regression to, a more differentiated stage of personality development” (Mahler, 1968, p. 71). Mahler viewed these disorders as emerging at certain key developmental landmarks—when the child

faces separation from the mother, for example, or when triggered by a specific event. Subsequently there developed a “dramatic disorganization along with loss of functions, such as deterioration of speech, often associated with or ascribed to such events. . . . By the third and fourth year of life, reorganization took place, with a range of psychotic symptoms in the foreground. These include: loss of boundaries of the self. . . , extreme reaction to any failure; magic gestures. . . , echolalia and echopraxia, psychotic preoccupations with an inanimate object. . . .” (p. 78). Unlike other psychoanalysts at the time, Mahler did not share the popular view that inadequate mothering was responsible for autism.

Mahler’s more influential work emerged from her research with normal children that began in the 1960s, when she created a program for directly studying young children in a setting that favored observation of mother-child interaction. Her theory of separation-individuation, which emerged directly from this research, distinguished clearly between psychological and biological birth. “The biological birth of the human infant and the psychological birth of the individual,” she wrote, “are not coincident in time. The former is a dramatic, observable, and well-circumscribed event; the latter a slowly unfolding intrapsychic process” (Mahler, Pine, and Bergman, p. 3).

*The Psychological Birth of the Human Infant*, published in 1975, was a mature statement of her theory. Mahler described the separation-individuation process as unfolding from the age of four to five months to thirty-six months of age and beyond. The earliest weeks of infancy constitute a period of psychic gestation that, in turn, is comprised of two stages: the normal autistic phase, during which the baby is centered on proprioceptive and enteroceptive sensation that represents a “model of a closed monadic system, self-sufficient in its hallucinatory wish fulfillment” (Pine, and Bergman, p. 41). It is followed by the symbiotic phase during which infant and mother form a “dual unity within one common boundary” (p. 44).

The separation-individuation process proper, Mahler suggested, begins at about four to five months of age and may be divided into four subphases. Differentiation, from about five months, Mahler viewed as a period of “hatching” of a primitive self from the earlier symbiotic attachment to the mother. In the practicing subphase (ten to twelve until sixteen to eighteen months), the infant becomes a “toddler” with growing

motor and cognitive skills who enjoys a “love affair with the world”; during rapprochement (sixteen to eighteen until twenty-four to thirty months) the toddler experiences both separateness and associated crises of dependency. A final, open-ended subphase that Mahler characterized as Toward Object Constancy, occurs as the child achieves an individual and variable measure of autonomy and emotional balance associated with a relatively stable, permanent, and differentiated intrapsychic representation of the mother.

Although recent research in infant and child development tends to emphasize the importance of innate capacities of newborn infants, not only in terms of perception and cognition but also in terms of attachment, Mahler’s theory remains an influential touchstone. The overall significance and influence of her work, most notably her concept of separation-individuation in normal psychological development, has been considerable and long-lasting.

PHILIPPE MAZET

*Notion developed:* Symbiosis/symbiotic relation.

*See also:* Absence; Adolescent crisis; Anxiety; Autism; Autistic defenses; Blos, Peter; Boundary violations; Developmental disorders; Hungarian School; Identity; Individual; Infant development; Lack of differentiation; New York Psychoanalytic Institute; Object relations theory; Paranoia; Self-mutilation in children; Unconscious fantasy.

### **Bibliography**

- Mahler, Margaret. (1949). A psychoanalytic evaluation of tic in psychopathology of children. *Psychoanalytic Study of the Child*, 3 (4), 279–310.
- . (1958). Problems of identity. *Journal of the American Psychoanalytic Association*, 6, 131–142.
- . (1968). *On human symbiosis and the vicissitudes of individuation*. New York: International Universities Press.
- . (1983). The meaning of developmental research of earliest infancy as related to the study separation-individuation. In *Frontiers of infant psychiatry* (pp. 3–6). New York: Basic Books.
- Mahler, Margaret, Pine, Fred, and Bergman, Anni. (1975). *The psychological birth of the human infant*. New York: Basic Books.
- Pine, Fred. (2004). Mahler Monday, November 22, 2004’s concepts of symbiosis and separation-individuation: Revisited, reevaluated, refined. *Journal of the American Psychoanalytic Association*, 52 (2), 511–533.

Stepansky, Paul. E. (1988). *The memoirs of Margaret S. Mahler*. New York: The Free Press.

## MAIN, THOMAS FORREST (1911–1990)

Thomas Forrest Main, a British physician, psychiatrist, and psychoanalyst, was born on February 25, 1911, in Johannesburg and died on May 25, 1990, in London. He graduated in medicine at Newcastle on Tyne in 1932 and was proud of his Geordie (Newcastle) background. He qualified for the MD in 1932, received the MD in 1934, then turned to psychiatry (DPM, 1936), and at a very young age became a consultant psychiatrist.

Main, one of the new generation of psychiatrists selected by John R. Rees, had a brilliant war career. To understand the stresses of war, he made parachute drops and went to the front line in France. In the training of soldiers, he condemned artificial attempts to stimulate hatred of the enemy, and he investigated the maintenance and loss of morale. He worked in the Eighth Army in the desert and in the twenty-first army group before the invasion of France. It was said that he and Field Marshal Montgomery could not get along with each other.

As a lieutenant colonel, Main was a senior figure at the Northfield Military Hospital, where he was a colleague of Siegmund H. Foulkes and Harold Bridger. This was at the time of the second Northfield experiment, the first having been that of Wilfred R. Bion and John Rickman. Main's famous paper ("The Ailment," 1957) stated that the hospital as an institution should study its own processes, thereby enhancing its therapeutic powers and recognizing its antitherapeutic aspects.

After the war Main became director of the Cassel Hospital for Functional Nervous Disorders and was responsible for moving the hospital close to London. He had two motives for doing this: First, patients should not be isolated from family and society, and second, staff should be close to London to avail themselves of psychoanalytic training. He himself had analysis with Michael Balint, and his supervisors were the grandes dames of British psychoanalysis, Anna Freud and Melanie Klein.

The hospital treated a wide range of neuroses and personality disorders and, under Main, began to treat mothers who had become psychologically ill after childbirth. Main pioneered admission to the hospital of

mothers with their babies, later with their older children, and eventually with husbands and the whole family.

Famous for his concept of the therapeutic community, a term that he originated, Main was especially skilled to hospital dynamics and psychosocial medicine. "The Ailment," reflected his observations on patients who engendered splitting and projective identification in the staff. Main was also a fine teacher and supervisor. Following Michael Balint's example, he led many Balint groups for family doctors and later developed Balint-group techniques for professionals treating sexual disorders. He founded and became the first president of the Institute for Psycho-Social Medicine.

A member of the British Psycho-Analytical Society, Main always maintained a psychoanalytic practice. Though he was not drawn to group-analytic psychotherapy, he appreciated the work of both Siegmund Foulkes and Wilfred Bion and wrote a classic paper on large-group dynamics. Another field that he explored was short-term psychotherapy, again collaborating with Michael Balint in a study eventually described by David Malan (1963).

Main, an important link between psychoanalysis and psychiatry, was active in the Royal College of Psychiatrists, of which he became vice-president. He was disappointed, however, that he did not become president, as he somewhat overoptimistically hoped and believed that he could help develop a psychodynamic psychiatry in Britain.

Fortunately, before his death his daughter Jennifer, herself a psychoanalyst, collected his papers in a book (1989). Main died from a carcinoma of the colon on May 25, 1990. His wife Molly, also a psychoanalyst and child psychiatrist, died in London in 1999. Two of their four children followed them into the field of psychiatry.

MALCOLM PINES

*See also:* Great Britain; Tavistock Clinic.

### **Bibliography**

- Hayley, Thomas T. S. (1991). Thomas Forrest Main, 1911–1990. *International Journal of Psycho-Analysis*, 72, 719–722.
- Main, Thomas F. (1957). The ailment. *British Journal of Medical Psychology*, 30 (3), 129–145.

———. (1989). *The ailment and other psycho-analytical essays*. London: Free Association Books.

Malan, David H. (1963). *A study of brief psychotherapy*. London: Tavistock.

## MÂLE, PIERRE (1900–1976)

French psychiatrist and psychoanalyst Pierre Mâle was born in Charolles, France, on October 11, 1900, and died in Paris on July 20, 1976.

The son of Émile Mâle, an eminent art historian and member of the French Academy, he performed brilliantly in his secondary school studies at the Lycée Henri IV. He studied medicine in Paris and in 1920 worked as an extern in the department of Henri Claude, the first professor to agree to supervise psychoanalysts. The 1920s were the years of Surrealism and the first translations of the works of Sigmund Freud. In 1926 Mâle was an intern in the staffroom at the Hôpital Sainte-Anne alongside Henry Ey and Jacques Lacan; he was among the first to undertake training analysis, initially with Rudolph Löwenstein, then resuming with Marie Bonaparte after World War I.

In 1926 the Société psychanalytique de Paris (SPP; Paris Psychoanalytical Society) was founded; Mâle was elected a member on June 21, 1932. Elected to permanent membership on April 20, 1948, he became the society's president after the schism of 1953, and in 1954 he inaugurated the Institut de psychanalyse de Paris (Paris Institute of Psychoanalysis), the leadership of which was entrusted to Sacha Nacht. In the face of the choices necessitated by the successive crises within French psychoanalysis, without discounting the importance of individuals' problems, his decisions were always based on the therapeutic vocation of psychoanalysis, in line with Freud's approach mandating a certain rigor in practice and training.

Beginning in the 1930s he participated in the emergence of child and juvenile psychiatry, under the influence of Georges Heuyer. In 1948, at the Hôpital Henri-Rouselle (part of Sainte-Anne), he created Guidance Infantile (Children's Guidance Center), where, initially seconded by Jean Favreau, his clinical practice and work became widely known. In this setting he taught a form of total clinical work in which psychoanalysis, the centerpiece, was in the service of a veritable anthropology, based on the comparative weight of conflicts, "equipment," and history, oriented toward a

multidisciplinary approach to the child and taking the family into account. Mâle was director of Guidance Infantile from 1948 to 1976.

From 1932, faithful to the contributions of Pierre Janet and Henri Wallon but inspired by Freud's *Three Essays on the Theory of Sexuality* (1905d), Mâle studied children's character and perverse behaviors in a new light, taking into account structures, but also events and instincts. If his preferred focus was adolescence, it was because that period seemed to him like a second birth in which buried material could come to the surface and be within reach of his activity in the operative field of the transference, a productive moment for intervention where it was possible to take up individual finality anew. The various forms of his therapies—in particular, short-term and non-ritualized versions—are elaborated in *Psychothérapie de l'adolescent* (Psychotherapy for adolescents, 1964) and relate to "the crisis of youth" and the "disharmonies of puberty," but also to criminality and "preschizophrenias," which topics he addressed, respectively, in 1951 with Serge Lebovici, and in 1958 with André Green.

At the beginning of the 1960s, Mâle began to focus on two adolescent states: "failure neurosis," expressed in terms of school performance, "pathology of error" and "refusal to succeed" (for which he proposed a combination of psychotherapy and an original curative pedagogy, developed with Thérèse Tremblais-Dupré), and "apathy," a phenomenon of modern society characterized by an absence of investment and intolerance of daily life, and heralding behaviors such as running away from home, delinquency, drug use, and suicide, which are most common among adolescents whose early home life was disturbed. Here, his observation of particular resistance to therapy pointed him, in the 1970s, toward research using a "vertical" approach to disturbed mother-child relations, together with Alice Doumic-Girard. Finally, with his friend René Held, Mâle contributed to the status of psychoanalytically inspired psychotherapy for adults.

Described by Philippe Gutton as leader of the French school of adolescent psychiatry (*Adolescence*, No. 1, 1983), Mâle continued to the end to expand the extraordinary possibilities of applying psychoanalysis in all areas and for patients of all ages. Pierre Bourdier and Ilse Barande, who succeeded Mâle as directors of the facility that was renamed Guidance infanto-juvenile Pierre Mâle (Pierre Mâle Children's and Youth

Guidance Center), worked alongside Simone Daymas to ensure the transmission of Mâle's life work.

PIERRE BOURDIER

*See also:* Adolescence; France; Loewenstein, Rudolph M.

### **Bibliography**

Barande, Ilse, and Daymas, Simone. (1994). Pierre Mâle et nous. *Perspectives psychiatriques*, 41, 17–23.

Mâle, Pierre. (1964). *Psychiatrie de l'adolescent*. Paris: Presses Universitaires de France.

———. (1982–1984). *Oeuvres complètes*. (Vol. 1: *La Crise juvénile*. Vol. 2: *De l'enfant à l'adulte*). Paris: Payot.

Mâle, Pierre, Doumic-Girard, Alice, Benhamou, Françoise, and Schott, Marie-Claude. (1975). *Psychothérapie du premier-âge. De la théorie à la pratique*. Paris: Presses Universitaires de France.

Tremblais-Dupré, Thérèse. (1982). Pierre Mâle, prince de la psychiatrie. *Scarabée Internationale*, 3–4, 204–211.

## **MALINOWSKI, BRONISLAW KASPAR (1884–1942)**

Bronislaw Kaspar Malinowski, a British anthropologist, was born on April 7, 1884, in Krakow, Poland, and died on May 16, 1942, in New Haven, Connecticut. The only son of a Slavic professor of philology, Malinowski completed a doctorate in the philosophy of science at the University of Krakow in 1908. After reading the work of James G. Frazer, he turned to anthropology. In 1910 he settled in Great Britain, where he studied with Charles G. Seligman and Edvard Westermarck at the London School of Economics.

During the First World War, although the Australian authorities considered him an enemy alien, he was still allowed to conduct ethnographic research and worked for a period of twenty months in the Trobriand Islands (Melanesia, to the east of New Guinea). At Seligman's request, he studied the Oedipus complex and other manifestations of the unconscious in a community based on maternal law.

In a series of articles, some of which appeared in *Sex and Repression in Savage Society* (1951) and *The Sexual Life of Savages in Northwestern Melanesia* (1962), he claimed that for the Trobriand people, "sex, in and of itself, was not subject to any form of restriction." There was no period of what Freud referred to as

pregenital or anal-erotic interest. "Any idea of consanguinity or paternal parenthood, conceived as a physical relation between father and child, is completely foreign to the indigenous mind." "The desire is to marry the sister and kill the maternal uncle." On the basis of these findings, Malinowski contested the universal validity of Freudian claims and denounced "the failure, even the explicit aversion, of psychoanalysts to seriously consider social organization."

As Ernest Jones and Géza Róheim were quick to point out, Malinowski's claims were not supported by a close examination of his own ethnographic data: A number of taboos, especially that of speech, influenced the sexuality of the Trobriand Islanders. Several convergent indices led to the conclusion that they understood physiological parenthood. A conventional Oedipal triangle seemed to be present: the son was the first to be suspected of killing the father through witchcraft. Malinowski himself acknowledged that he was unfamiliar with the psychoanalysis he relativized and criticized. He was unaware of the distinction between the latent and the manifest, and directly questioned the native population about the incestuous content of their dreams. Moreover, his writing can be questioned in terms of his peculiar mental equations, which the posthumous publication of his *Diary in the strict sense of the term* (1967) allows us partially to reconstruct.

The head of the so-called functionalist school, Malinowski benefited from his considerable fame: He held the first chair of anthropology at the University of London, which was created for him in 1927. Even in the early twenty-first century, his Trobriand Island work is presented by anthropologists as a key moment in intensive ethnography (prolonged residence, knowledge of the language). His theoretical perspectives have largely been abandoned, but a number of anthropologists continue to refer to his work to refute the universality of the Oedipus complex and the ability of psychoanalysis to account for the workings of the psyche in variable social contexts.

BERTRAND PULMAN

*See also:* Ethnopsychanalysis.

### **Bibliography**

Malinowski, Bronislaw. (1951). *Sex and repression in savage society*. New York: Humanities Press. (Original work published 1927)



———. (1962). *The sexual life of savages in northwestern Melanesia: An ethnographic account of courtship, marriage, and family life among the natives of the Trobriand Islands, British New Guinea*. New York: Harcourt, Brace & World. (Original work published 1929)

———. (1967). *A diary in the strict sense of the term*. London: Routledge & Kegan Paul.

Pulman, Bertrand. (1991). Psychanalyse et anthropologie. *Revue internationale d'histoire de la psychanalyse*, 4, 425–521.

Spiro, Melford. (1982). *Oedipus in the Trobriands*. Chicago: University of Chicago Press.

## MANIA

Mania is a state of psychomotor excitation. Its onset most often comes through inversion of a melancholic mood, either spontaneously or owing to treatment for depression.

The manic mood is euphoric, changeable, and accompanied by emotional hyperesthesia. The subject exhibits pathological optimism with an overestimation of the self and unrealistic plans that sometimes lead to delusions along megalomaniacal lines (grandeur, omnipotence, messianism). The expansiveness of mania is associated with agitation, expressed in hyperactivity and hypermimia. It is also accompanied by tachypsychia (“rushing thoughts”), an acceleration of the thought processes externally manifested in logorrhea, graphorrhea, hypermnesia, and distractibility. Hypersyntony, a immediate and increased receptivity to stimuli from the outside world and a loss of the ability to discriminate between important facts and details, gives the impression that the subject is closely emotionally attuned with his or her surroundings. Reduction in the duration of sleep, sometimes to the point of total insomnia, is a constant clinical sign.

In “Mourning and Melancholia” (1916–17g [1915]), based on his impressions as an analyst, Sigmund Freud observed that melancholic and manic patients were “wrestling with the same ‘complex’” (p. 254)—a complex to which the melancholic ego succumbs and over which the manic ego triumphs. From nonpathological states of jubilation, triumph, and joy, he extrapolated the economic precondition of mania: It corresponded to a fresh availability of the psychic energy expended in the unconscious work of

melancholia, which in mania again becomes “available for numerous applications and possibilities of discharge” (p. 254). At the point where melancholia turns into mania, the subject’s ego is liberated from the object of its suffering; it surmounts its loss and triumphs over the object, and consequently the psychic energy that has been counter-catheted and bound to mental pain is suddenly available. In mourning there is no liberation of this type, for detachment from the object is more gradual, although Karl Abraham (1924/1927) viewed the increase in libidinous desires in some bereaved persons as comparable to mania.

From a topographical viewpoint, Freud showed in “Group Psychology and Analysis of the Ego” (1921c), that whereas a severe ego ideal crushes the melancholic’s ego with its rigorous control, during mania it is suddenly absorbed or merged into the ego. The ego and the ego ideal of the manic subject become one, thus freeing the subject from all hindrances and all criticism, procuring for the subject a feeling of triumph and boundless satisfaction.

For Abraham, “the manic patient has thrown off the yoke of his super-ego, which now no longer takes up a critical attitude towards the ego, but has become merged in it” (1924/1927, p. 471). Abraham compared mania to a cannibalistic orgy. The manic subject, he argued, manifests an “increase in . . . oral desires” (p. 472) a veritable object-bulimia. This accelerated incorporation of the object is immediately followed by an “equally pleasurable act of ejecting [introjected objects] almost as soon as they have been received” (p. 472). The subject’s “psychosexual metabolism” (p. 472) thus appears to be significantly accelerated.

ALBAN JEANNEAU

*See also:* Acute psychoses; Manic defenses; Melancholia; Megalomania; *Mourning and Melancholia*; Reparation; Secondary revision; Self-representation; Suicide.

### Bibliography

Abraham, Karl. (1927). Notes on the psycho-analytical investigation and treatment of manic-depressive insanity and allied conditions. In *Selected Papers of Karl Abraham, M.D.* (pp. 137–156). London: Hogarth and the Institute of Psycho-analysis. (Original work published 1911)

———. (1927). A short study of the development of the libido, viewed in the light of mental disorders, In *Selected*

*papers of Karl Abraham, M.D.* (pp. 418–201). London: Hogarth and the Institute of Psycho-analysis. (Original work published 1924)

Freud, Sigmund. (1916–17g [1915]). Mourning and melancholia, *SE*, 14: 237–258.

———. (1921c), Group psychology and the analysis of the ego. *SE*, 18: 65–143.

## MANIC DEFENSES

The notion of *manic defenses* was introduced by Melanie Klein as an extension of Freud's thoughts on mania. By adopting a triumphantly scornful attitude toward psychic reality, the patient uses this kind of defense to avoid the depression associated with the conviction of having destroyed an internal object.

In "Mourning and Melancholia" (1916–17g [1915]), Freud wrote: "In mania, the ego must have got over the loss of the object (or its mourning over the loss, or perhaps the object itself)... [T]he manic subject plainly demonstrates his liberation from the object which was the cause of his suffering" (p. 255). Karl Abraham elaborated on Freud's view by attributing manic triumphalism to a liberation from the sway of the ego ideal or of an incorporated object.

In the context of her theories on the depressive position, Melanie Klein (1940) emphasized the importance of manic defenses for mental life. She enriched the Freudian conception of mania by adding the idea of the subject's feelings of guilt concerning the disappearance and destruction of the object. The manic subject tends to downplay the power of the object, to disdain it, while at the same time maintaining maximum control over objects. Manic defenses are typified by three feelings, namely control, triumph, contempt.

In clinical practice, the notion of manic defenses has suffered from the rise of a psychiatric approach that tends to sideline any consideration of psychic conflict.

ELSA SCHMID-KITSIS

*See also:* Defense; Depressive position; Mania; Megalomania; Melancholia; Reparation.

### Bibliography

Freud, Sigmund. (1916–1917g [1915]). Mourning and melancholia. *SE*, 14: 237–258.

Klein, Melanie. (1940). Mourning and its relation to manic-depressive states. *International Journal of Psychoanalysis*, 21: 125–153.

## MANIFEST

Manifest content is the narrative that the dreamer tells about his or her dream. In contemporary usage, the criterion *manifest* is also applied to other types of verbal production and to behaviors. Sigmund Freud contrasted manifest content to the latent dream thoughts brought out by psychoanalytic interpretation.

The Freudian theory of dreams "is not based on a consideration of the manifest content of dreams but refers to the thoughts which are shown by the work of interpretation to lie behind dreams" wrote Freud in *The Interpretation of Dreams* (1900a, p. 135).

Manifest and latent are notions by the "dream work." During sleep, wishes linked to childhood events, normally repressed, are actualized owing to the relaxation of censorship. Dreaming requires, however, that "selfish," sexual, sadistic, or incestuous wishes be transformed. The dream fulfills these wishes ("latent thoughts," "latent contents," "dream thoughts"); only if they are modified, distorted, and/or transformed in their expression, which is the manifest dream. But the manifest dream is also a product of the effects of certain events of the previous day (day's residues) or of bodily sensations on the unconscious. The manifest dream results from a combination of the day's residues, bodily sensations, and latent dream-thoughts. The regression to archaic forms of thought provoked by sleep entails the repression and transformation of the latent thoughts. A secondary revision, which gives the dream a certain coherence, then succeeds to these transformations. What is manifest may therefore function as a "façade" or "trompe-l'oeil."

Interpretation of the manifest dream entails following the path of the dream work in reverse and, by tracking associations and uncovering the latent thoughts, although Freud stressed that there were limits to the interpretation of dreams (see his discussion of the "dream's navel," 1900a, p. 525).

Over time, the opposition between manifest and latent posited by Freud in his earliest works was reconsidered. However, he continued to refer to it even as late as his "Outline of Psycho-Analysis" (1940a [1938]), as a means of understanding and working out dreams.

The exigencies of the second topography (or structural model), with its complex picture of the mental agencies (the ego being deeply rooted in the id) made the opposition between manifest and latent more difficult in relation to dreams. The dream became one form of material among others, caught up in the movements of transference and resistance. The analyst's goal was no longer conceived as the revelation of what was unconscious or rather as latent through the interpretation of dreams, but rather as development of the psychoanalytic process. Manifest and latent were seen as interpenetrating instead of radical opposites. The manifest could therefore be treated, much like the latent, in the work of the session.

The initial importance assigned in the theory of dreams to the manifest, making it as important, in fact, as the latent, was reduced: Analytical treatment came to focus on the dynamics of the latent psychic functioning of the analyst and the analysand. Dreams were also considered in their totality, as a space of projection/protection, and as a mode of expression for the dreamer in their very nonsense (Jean-Claude Lavie)—simply another mode for apprehension of the manifest.

In the treatment, behaviors (attitude, gestures, somatization) are manifest forms of a latent mode of psychic functioning in the patient. But because they are outside the patient's consciousness and verbalization, they elude the process of working over. They can be related to early modes of psychic functioning, when the dynamics of the one remained indistinctly linked to the primal other. The mechanisms involved are thus splitting, repetition, and reversal into the opposite.

The nonverbal manifest and the latent it conceals can be discovered by the patient, notably in situations where bonds of identification and transference are developed by means other than those used in treatment, and where expressiveness through the body, actions, and attitudes emerges in situations such as analytic role-playing and/or small-group situations with analysts.

ANDRÉ MISSENARD

*See also:* *Apprenti-historien et le maître-sorcier*, *L'* [The apprentice historian and the master sorcerer]; Censorship; Condensation; Conflict; Displacement; Dream; Dream symbolism; Dream work; Interpretation of dreams (analytical psychology); Interpretation; *Interpretation of Dreams*,

*The*; Language and disturbances of language; Latent; Latent dream thoughts; Representability; Secondary revision; Symbol.

### Bibliography

Freud, Sigmund. (1900a). The interpretation of dreams. *SE*, 4–5: 1–625.

———. (1940a [1938]). An outline of psycho-analysis. *SE*, 23: 139–207.

Lavie, Jean-Claude. (1972). Parler à l'analyste. *Nouvelle Revue de psychanalyse*, 5, 287–298.

---

## MANN, THOMAS (1875–1955)

German writer Thomas Mann was born in Lübeck, Germany, in 1875 and died in Kilchberg, near Zurich, Switzerland, in 1955. He settled in Munich with his family after the death of his father, remaining until 1936; he then went into exile in the United States. His life and work were dominated by two major questions: Germany and German identity; the status of the artist and art in society.

Concerning the question of German identity, Mann began by holding conservative, monarchist, and militarist beliefs until the rise of Nazism. He opposed a Germanic ideal that accepted values held by the rest of Europe. In this he distanced himself from the position of his brother Heinrich Mann, a republican, cosmopolitan, and critic of the Empire. During this time, Mann's literary output began with a lengthy autobiographical novel, *Buddenbrooks* (1901), in which he describes the decline of four generations of a rich Hanseatic family. The fate of this fictional family can be compared with his own experience of the loss of his father while he was still very young. After dabbling briefly with Nazi ideology, Mann underwent a fundamental change of opinion in the thirties. It was in his novel *The Magic Mountain* (1924) that he developed his new attitudes toward all the most important areas of thought and action, including psychoanalysis.

Mann contrasted the mediocrity of an average, bourgeois existence with the unconscious drives of the sensitive intellectual enamored of knowledge and beauty. He continued to articulate, throughout the course of his work, series of paired opposites: art and morality, art and civilization, culture and society, the genius of disease and the stupidity of health. He contrasted the North, cold and puritan, where his family

had come from, with the South, Bavaria, where he lived. This was the carnal South of Tonio Kröger (1903), the mephitic Venice of Gustav Aschenbach (1910), the voluptuous Egypt of Joseph (1933–1934), the magic mountain of Hans Castorp—all of them fantasies of the experience of forbidden desire, places of love and death, of disease, of castration.

He contrasted liberating psychoanalysis with an alienating hypnosis. In *Mario and the Magician* (1929), Mann created a portrait of a disturbing illusionist who evokes Hitler. And in 1938, after the Anschluss, Mann contrasted Freud with Hitler: “How that man must hate analysis! I secretly suspect that the furor with which he marched against a certain capital was at bottom directed against the old analyst living there, his real enemy, the philosopher who unmasked neurosis, the great disillusionist, the man who knows so much about belief and genius.”

Mann praised Freud directly on several occasions. From his “My Relationship with Psychoanalysis” of 1926, where he exposes his ambivalence toward Freudian theories, to the two texts written for the seventy-fifth and eightieth birthdays of Sigmund Freud, where he is compared, using an allegory from a Dürer painting, to the knight between death and the devil, Mann saw Freud as the “pioneer of a humanism of the future.”

DIDIER DAVID

See also: *Psychoanalytische Bewegung, Die*; German romanticism and psychoanalysis.

### Bibliography

Finck, Jean. (1982). *Thomas Mann et la psychanalyse*. Paris: Les Belles Lettres.

Mann, Thomas. (1941). Freud's position in the history of modern culture. *Psychoanalytic Review* 28 (1), 92–116.

———. (1996) *Être écrivain allemand à notre époque*. Paris: Gallimard.

## MANNONI, DOMINIQUE-OCTAVE (1899–1989)

French philosopher and psychoanalyst Dominique-Octave Mannoni was born on August 29, 1899, in Lamotte-Beuvron (Loir-et-Cher), a small town in the Loire Valley, and died in Paris on July 30, 1989.

The son of a Corsican director of a disciplinary institution, Mannoni studied philosophy in Strasbourg, where his professor of psychology, the influential Charles Blondel, was positively hostile to psychoanalysis. In 1926, after completing his studies, he was appointed to the Lycée Gallieni in Tananarive. He would remain in Madagascar until 1945, when he was sent back to France for having supported the island's independence movement. During this period he published numerous literary and ethnographic articles.

In Paris, Mannoni began analysis with Jacques Lacan in 1946 and wrote *Psychologie de la colonisation*, published in 1950, which was to appear in English as *Prospero and Caliban: The Psychology of Colonization* (1956), and which became the subject of critiques by both Aimé Césaire and Frantz Fanon. After the famous split with the International Psychoanalytical Association in 1953, Mannoni joined the Société Française Psychanalytique (SFP); but ten years later, due to his close relationship with Lacan, he was not elected a full member; as one consequence, he lost interest in the administrative and political side of psychoanalysis.

Beginning with his return to Paris, Mannoni wrote regularly for Maryse Choisy's review *Psyché*, serving among other duties as film critic; his articles also appeared in *Esprit* and, still more prominently, in *Les temps modernes*, for which he continued to write until his death. He became a member of the École freudienne de Paris (EFP) and was appointed analyst of the school (AE), a position he retained until the EFP closed in 1980. In 1982, with Patrick Guyomard he co-founded the Psychoanalytic Training and Research Center (CFRP), which was established on the initiative on his wife, Maud Mannoni.

Cultivated and independent, open to various avenues of thought in philosophy, anthropology, ethnology, and French and English literature, Mannoni remained aloof from the institutions to which he belonged. He avoided both administrative duties and fealty to either persons or theories. His work, of considerable importance, includes collections of articles on psychoanalysis and evaluations of literary figures. In his *Lettres personnelles à monsieur le Directeur* (1951), he undertook to “decolonize himself,” a result of his analysis with Lacan. In 1968, he published a remarkable essay, *Freud*, which was widely translated. The lecture he composed after his failure to be appointed a full member of the SFP was published as

“Je sais bien mais quand même” (I understand but still ...; 1963). His famous article on Freud’s relationship with Fliess, “L’analyse originelle” (The first analysis), appeared in 1967. “In 1907,” Mannoni explained in that essay, “Freud was finally able to repeat with another the experience he had first undergone himself; and by making it repeatable, his experience became the first.”

JACQUES SÉDAT

*See also:* Fanon, Frantz; France; Mouvement lacanien français; Lacan, Jacques; Mannoni-Van der Spoel, Maud (Magdalena).

### **Bibliography**

- Mannoni, Octave. (1951). *Lettres personnelles à monsieur le Directeur*. Paris: Denoël.
- . (1956). *Prospero and Caliban: The psychology of colonization*. London: Methuen.
- . (1969). *Clefs pour l’imaginaire*. Paris: Le Seuil.
- . (1971). *Freud* (Renaud Bruce, Trans.). New York: Pantheon. (Original work published 1968)
- . (1990). *Nous nous quittons. C’est là ma route*. Paris: Denoël.

---

## **MANNONI-VAN DER SPOEL, MAUD (MAGDALENA) (1923–1998)**

French psychoanalyst Maud (Magdalena) Mannoni née Van der Spoel (was born on October 22, 1923), in the Belgian city of Courtrai and died in Paris on March 15, 1998.

With her mother, who was Belgian, and her father, a Dutch diplomat, she spent her early childhood in Colombo, Ceylon (present-day Sri Lanka); her first languages were Hindustani and English, both later forgotten after she returned to Belgium at age six. She studied criminology at the University of Brussels and began a training analysis with Maurice Dugautiez, one of first Belgian psychoanalysts. She would remain until her death a full member of the Belgian Psychoanalytic Society, an affiliate of the International Psychoanalytical Association (IPA).

Moving to France in 1949, she settled in Paris, met Françoise Dolto, married Octave Mannoni, and had both analysis and training analysis with Jacques Lacan,

whom she supported during the 1953 split in the French psychoanalytic movement. Mannoni worked with retarded children at several institutions and her *L’enfant arriéré et sa mère* (1964) was the first title to appear in “Le champ freudien,” a series under the editorial direction of Lacan published by Le Seuil. She went on to write numerous books for an analytic audience on childhood psychopathology. Her view of the child as “spokesperson” for the dysfunctional family helped render obsolete the concept of “retardation” (*débilité*) then widely used in medico-social discourse in France. The child who appeared “retarded” was in fact waiting to be heard.

Mannoni’s work in child psychology led her in 1969 to found the residential community known as École expérimentale de Bonneuil, which she directed until her death. The institution, which operated beyond traditional boundaries and used a variety of therapeutic strategies, with workshops and internships within and outside the school environment, became internationally renowned. Upon dissolution of the L’École freudienne in 1980, Mannoni appealed for the creation of training institute for young analysts and, with her husband and Patrick Guyomard, she established the Centre de formation et de recherches psychanalytiques (Center for psychoanalytical training and research; CFRP). Subsequently, internecine quarrels led to a crisis that went so far as to entail legal action against Mannoni herself. After the plaintiff’s suit was dismissed, she called for dissolution of the CFRP, which was duly voted on January 30, 1995. Several months earlier on October 16, 1994, at the end of a contentious general assembly of the CFRP, she had founded the “Espace analytique.” She remained its president until her sudden death from heart disease.

At the end of her life, Mannoni wrote of the practice of analysis that its lively dynamisms were “akin to the energy of the poets or of those who work face to face with poverty.” These words epitomize both her unflagging engagement with writing and her attentiveness to those areas where psychoanalysis confronts life’s hardships.

JACQUES SÉDAT

*See also:* École expérimentale de Bonneuil; France; Infantile psychosis; Mannoni, Dominique-Octave; Mouvement lacanien française; Pass, the.

**Bibliography**

- Mannoni, Maud. (1970). *Le psychiatre, son fou et la psychanalyse*. le Seuil.
- . (1972). *The backward child and his mother; a psychoanalytic study*. (A. M. Sheridan Smith, Trans.). New York: Pantheon. (Original work published 1964)
- . (1979). *La théorie comme fiction: Freud, Groddeck, Winnicott, Lacan*. Paris: le Seuil.
- . (1987). *The child, his "illness," and the others*. London: Maresfield.
- . (1995). *Les mots ont un poids, ils sont vivants*. Paris: Denoël.
- . (1998). *Elles ne savent pas ce qu'elles disent*. Paris: Denoël.
- . (1999). *Separation and creativity: Refinding the lost language of childhood*. New York: Other Press.

**MARCINOWSKI, JOHANNES (JAROSLAW) (1868–1935)**

Johannes (Jaroslaw) Marcinowski, a German neurologist, was born in Breslau, Poland, on November 13, 1868, and died in Tübingen-Waldhausen, Germany, on February 13, 1935.

He was the son of Johanna and Johann Gottlieb Marcinowski; his father was an administrative councilor. He attended a cadet training college and graduated as an officer. He was wounded in the course of his military career and subsequently devoted himself to medical studies, graduating from the University of Breslau as a doctor of medicine in 1894. From 1901 onward he worked as a neurologist in different treatment centers and in 1907 he founded his own center (Haus Sielbeck bei Eutin, in the province of Holstein).

Carl Gustav Jung drew Freud's attention to one of his papers. Freud responded: "Today I received a charming letter from Marcinowski, in which he declares himself to be our staunch supporter and comrade in struggle. He tells me that three further papers are being published in various places. He is trying to make contact with our group and is asking for addresses" (Freud and Jung, 1974a [1906–1913], p. 231).

Freud mentions Marcinowski's rest home in *On the History of the Psycho-Analytic Movement* (1914d) as the first German institution to open its doors to psychoanalysis. At the second psychoanalytic Congress, held in

Nuremberg in 1910, Marcinowski gave a conference on *Sejunktive Prozesse als Grundlage der Psychoneurosen* (Sejunctive processes as the foundation of the psychoneuroses). In the fall of 1911 he was appointed a permanent collaborator of the *Zentralblatt für Psychoanalyse* as well as the *Internationale Zeitschrift für (ärztliche) Psychoanalyse* from 1913 to 1919. He was a member of the regional Berlin group affiliated to the International Psychoanalytical Association from 1912, and remained a member until he was admitted to the Vienna Psychoanalytic Society in 1919.

After World War I he acquired a farm at Heilbrunn bei Bad-Tölz in Upper Bavaria and transformed it into a clinic, which he directed until 1928. In 1919 he became a member of the Leonhard Seif's society: *Gesellschaft für angewandte Seelenkunde* (Society for applied psychology) in Munich. He resigned one year later along with psychoanalysts Hans von Hattingberg and Viktor von Gebattel because Seif, who was already close to Adler and then Jung, was moving too far away from Freudian concepts.

Marcinowski developed his own form of psychotherapy and from the mid-1920s he can no longer be classified in any given sector. He gave conferences on psychoanalysis in the context of the *Arbeitsgemeinschaft für medizinische Psychologie* (Study group for medical psychology) founded by Carl Gustav Heyer at the University of Munich in 1925. He published in Hans von Hattingberg's collection *Der nervöse Mensch* (The nervous man), collaborated in the *Zeitschrift für Menschenkunde* (Review of anthropology) founded by Hattingberg in 1925, in Wilhelm Stekel's publications, and in other medical and psychotherapeutic reviews. He died on February 13, 1935, in Tübingen-Waldhausen, where he had lived with his family since 1928 and where he had opened another rest home, which his wife continued to run after his death.

ELKE MÜHLEITNER

*See also:* Germany.

**Bibliography**

- Freud, Sigmund. (1914d). On the history of the psychoanalytic movement. *SE*, 14: 1–66.
- Freud, Sigmund and Jung, Carl Gustav (1974a). *The Freud/Jung letters: The correspondence between Sigmund Freud and C. G. Jung*. (William McGuire Ed., Ralph Manheim and R.F.C. Hull, Trans.). Princeton, NJ: Princeton University Press.

Marcinowski, Johannes. (1904). *Im Kampf um gesunde Nerven. Ein Wegweiser zum Verständnis und zur Heilung nervöser Zustände*. Berlin: O. Salle.

———. (1905). *Nervosität und Weltanschauung. Studien zur seelischen Behandlung Nervöser nebst einer kurzen Theorie vom Wollen und Können*. Berlin: O. Salle.

———. (1916). *Neue Bahnen zur Heilung nervöser Zustände. Ein Stück Lebenskunst für alle*. Berlin: O. Salle.

Mühlleitner, Elke. (1992). *Biographisches Lexikon der Psychoanalyse (Die Mitglieder der Psychologischen Mittwoch-Gesellschaft und der Wiener Psychoanalytischen Vereinigung 1902–1938)*. Tübingen: Diskord.

## MARCONDES, DURVAL BELLEGARDE (1899–1981)

Durval Bellegarde Marcondes was born in São Paulo on November 27, 1899, and died there on September 27, 1981. He was one of the leading promoters of psychoanalysis in Brazil.

In 1919, while still a medical student in São Paulo, he learned of the existence of Freud's work through the efforts of his professor, Franco da Rocha. In 1925, having completed his medical training, he opened consultation rooms where he received patients suffering from neuroses and treated them using the psychoanalytic technique. Moreover, he was the only early practitioner of psychoanalysis in Brazil to later submit to orthodox training and to practice throughout his life, thus becoming a "pioneer," according to Marialzir Perestrello's classification in *Primeiros Encontros com a Psicanálise no Brasil* (1899–1937).

In 1927 Marcondes conceived of and founded the first *Sociedade Brasileira de Psicanálise* (Brazilian psychoanalytic society). The stated goal of this institution was "to bring together people who are interested in studying Freudian theory and spreading these ideas." Juliano Moreira also founded an affiliate psychoanalytic society in Rio de Janeiro. The *Revista brasileira de psicanálise* (Brazilian review of psychoanalysis) was launched in 1928. A copy of the first issue was sent to Freud, who responded to Marcondes with this letter on June 27, 1928: "Dear Colleague. The content of the new *Revista brasileira de psicanálise* gave me great pleasure. May it have a fruitful future! As a result of this dispatch, I bought a small Portuguese grammar book and a German-Portuguese dictionary. I am curious to see whether I can manage to read the review for myself dur-

ing these holidays. Greetings and many thanks, yours Freud." In another letter to Marcondes in 1928, Freud asked the members of the newly founded society to request to be affiliated to the International Psychoanalytical Association (IPA). Volumes 10 (p. 515, 1929) and 12 (p. 510, 1931) of the *International Journal of Psychoanalysis* record that the group did respond to Freud's suggestion, with an informal request that was favorably received by Max Eitingon, then president of the IPA.

In 1930 Marcondes received a publication from Eitingon, celebrating the tenth birthday of the Berlin Psychoanalytic Institute (BPI). The publication contained a description of the system of psychoanalytic training developed and perfected by the institute, based on training analysis, supervisions, and theoretical/technical studies. Marcondes was immediately convinced of the necessity of establishing the same training system in Brazil and the need to invite a training analyst to help. René Spitz was the first choice but the political situation prevented the project from coming to fruition: the constitutionalist uprising of 1932 brought São Paulo into military opposition with the rest of country and caused the federal government to impose a blockade on communications in the state of São Paulo. Another occasion to invite an IPA-approved psychoanalyst did not present itself until November, 1936, when Dr. Adelheid Koch arrived in São Paulo. Marcondes was among the first six people to be analyzed by the Berlin analyst.

Marcondes played an active part in the life of psychoanalytic institutions. He was president of the São Paulo branch of the *Sociedade Brasileira de Psicanálise*, a mandate he received twice. He helped found the *Associação Brasileira de Psicanálise* in May 1967 and became its first president.

In 1938 he created the mental hygiene section of the school health service in São Paulo and became its first director. In it he developed a program of infantile mental hygiene on psychoanalytic bases, thus creating a hitherto unknown occupational category in Brazil: mental health workers and psychiatric advisors that visited homes, the precursors of psychologists. Some of these mental health professionals went on to become psychoanalysts. Marcondes made the profession accessible to non-physicians, this being a distinctive feature of the São Paulo section of the *Sociedade Brasileira de Psicanálise*. Marcondes taught in the School of Political Sociology, in the Public Health Faculty, in the Psychology Institute, in the University of São Paulo, and in the Catholic Pontifical University of São Paulo.

He wrote many articles on psychoanalysis and art criticism, and in 1951 he published a book, *A Medicina e a Psicologia* (Medicine and psychology).

FABIO HERMANN AND ROBERT YUTAKA SAGAWA

See also: Brazil.

### Bibliography

Bicudo, Virginia L. (1948). Contribuição para a história do desenvolvimento da psicanálise em São Paulo. *Arquivos de neuropsiquiatria*, 6, 1.

Galvão, Luis Almeida Prado. (1967). Notas para a história de psicanálise em São Paulo. *Revista brasileira de psicanálise*, 1 (1), 46–68.

Marcondes, Durval. (1951). *A Medicina e a Psicologia*. São Paulo: Martins.

Perestrello, Marialzira. (1985). Primeiros encontros com a psicanálise, 1899–1937; Os precursores do movimento psicanalítico no Brasil, 1899–1937. *Jornal brasileiro de psicanálise*, 35 (4), 195–208.

———. (1992). Histoire de la psychanalyse au Brésil des origines à 1937. *Frénésie*, 2 (10), 283–304.

———. (1992). *A Psicanálise no Brasil. Encontros: psicanálise*. Rio de Janeiro: Imago.

Sagawa, Roberto Yutaka. (1996). *A Construção local da psicanálise*. Marília: Interior-Psicanálise.

## MARCUSE, HERBERT (1898–1979)

Herbert Marcuse, an American philosopher of German origin, was born in Berlin in 1898 into an assimilated Jewish family and died in 1979 in Starnberg, Germany, where he had returned after World War II. He studied philosophy in Berlin and Fribourg, and his doctoral dissertation, *Hegel's Ontology and the Theory of Historicity* (1987), was sponsored by Martin Heidegger. He militated against social democracy, defended a critical Marxism, and participated, along with Max Horkheimer and Theodor Adorno, in the creation of the Institute for Social Research in Frankfurt. When Hitler came to power in 1933, Marcuse left Germany for the United States and taught at different universities: New York, Columbia, Harvard, Brandeis, and the University of California at San Diego.

He had a Marxist training and in 1958 published *Soviet Marxism: A Critical Analysis*. He also harbored a passionate yet critical interest in psychoanalysis. These

two facets of Marcuse contributed to his writing, where one can discern individual libidinal structures and economic, political, and social realities characterized by domination and alienation continuously coming into conflict. His best-known works were widely read by students in the United States and Europe in the 1960s. In *Eros and Civilization: A Philosophical Inquiry into Freud* (1955) and *One Dimensional Man* (1964), he denounced “repressive sublimation” in consumer society, where society caters to the individual's drives only to better control the individual. Ever the rebel, Marcuse also published *Reason and Revolution* (1941), *An Essay on Liberation* (1968), and *Counterrevolution and Revolt* (1973).

ROGER DADOUN

See also: France; Marxism and psychoanalysis; Philosophy and psychoanalysis; Politics and psychoanalysis; Sociology and psychoanalysis/sociopsychanalysis.

### Bibliography

Marcuse, Herbert. (1941). *Reason and revolution: Hegel and the rise of social theory*. New York: Oxford University Press.

———. (1958). *Soviet Marxism: A critical analysis*. New York: Columbia University Press.

———. (1955). *Eros and civilization: A philosophical inquiry into Freud*. Boston: Beacon.

———. (1964). *One dimensional man: Studies in the ideology of advanced industrial society*. Boston: Beacon Press.

———. (1968). *An essay on liberation*. Boston: Beacon Press.

———. (1973). *Counterrevolution and revolt*. Boston: Beacon Press.

———. (1987). *Hegel's ontology and the theory of historicity* (Seyla Benhabib, Trans.). Cambridge, MA: MIT Press.

Nicolas, André. (1969). *Marcuse, ou la quête d'un univers trans-prométhéen*. Paris: Seghers.

Palmier, Jean Michel. (1969). *Sur Marcuse*. Paris: Union générale d'éditions. (Also published under the title *Présentation d'Herbert Marcuse*.)

## MARTINIQUE

Psychoanalysis is a relatively recent activity in Martinique. West Indian intellectuals studying in Paris in



the 1930s nevertheless showed an early interest in it. Martinican students could thus declare, in the review *Légitime défense* (Legitimate defense): “As for Freud, we are ready to use the immense machine for dissolving the bourgeois family that he set in motion.”

The poetic works of Aimé Césaire began to be published in 1939 and were hailed by André Breton as “The greatest lyrical monument of our time [...] a general abdication of the mind.” There is a definite influence of a Surrealist version of psychoanalysis on a poetic project that set as one of its major goals the exploration of the depths of the black psyche.

Frantz Fanon, the Martinican psychiatrist, criticized psychoanalysis in 1952. He claimed that Freud, Jung, and Adler had not thought of blacks in their research. Similarly, he saw the Oedipus complex as being impossible in West Indian families. For more than twenty years the complex conflicts surrounding decolonialization in the West Indies were to make Fanon’s critique the breeding ground for resistance to psychoanalysis in the name of a cultural determinism with uncertain principles. The few people who took any interest in psychoanalysis had no more than a bookish knowledge of it.

The first psychoanalytically-informed work in Martinique began in 1973: interpreting children’s drawings, a seminar directed by the French child psychiatrist Bernard Bousquet. But the true beginning of psychoanalysis in Martinique dates from 1974. It derived from the presence of a Swiss couple, Pierre and Lucette Stittelmans, two non-physician psychoanalysts. Shipwrecked on their way to the Trobriand Islands (Papua New Guinea), they had to land on the island. Their stay was extended until 1980. The Stittelmans had been trained by and were members of the Swiss Psychoanalytic Society (affiliated with the International Psychoanalytical Association [IPA]). They thus provided analysis, training and supervision for all who wished to become psychoanalysts.

In October 1975 the first psychoanalytic group came into being: the Groupe antillais de recherche, d’étude et de formation psychanalytique (GAREFP; The West Indian Group for Psychoanalytic Research, Study and Training), the founding members being Héliane Bourgeois and Luce Descoueyte, along with Mrs. Marcel Manquant and Mrs. Raymond Saint-Louis Augustin. From 1975 to 1980 this group worked to secure theoretical training of its members with analysts from the Paris Psychoanalytic Society,

affiliated to the IPA. Among the members were Florence Guignard, Jean Bégoïn, René Diatkine, and Michel Neyraut. There was also an initial collaboration with Roberto Fontaine of Venezuela for transactional analysis. Dr Mauriello, a Martinican psychoanalyst living in Quebec, also contributed to the effort.

Following the trauma occasioned by the departure of the Stittelmans in 1980, the GAREFP developed a Lacanian orientation that increased with time, some of the founding members having decided to withdraw from the group.

December 1990, saw the birth of another association, the Forum, the founding members being Benedetta Jumpertz, Marcel Manquant, and Guillaume Suréna. It organized the first Martinican symposium on psychoanalysis in March 1991. It organizes training for its own members and is not affiliated with any external psychoanalytic associations. Its members come from various different backgrounds but it sees Freud’s work as its cornerstone. In this sense it could be said to identify with the IPA orientation, although it is not a member.

The absence of West Indian doctors and academics is easily noticeable. Twenty-five years after the introduction of psychoanalysis, there were only two Martinican psychiatrists practicing psychoanalysis there and the two existing associations had been founded by non-physicians. Psychoanalysis has no direct influence on either the medical or the academic world. The paramedical and in the psycho-educational sectors have displayed a certain amount of interest.

As of 2005, psychoanalysis does not yet play any significant role in West Indian culture. It is not present in questions of national identity, literary debates, or political aspirations. Martinican psychoanalysis has not yet created distribution networks. A very small number of individuals have written clinical and theoretical papers but there has been no substantial contribution to psychoanalytic theory.

This psychoanalysis is evolving in isolation in relation to the Caribbean, like Martinique itself. There are a few practitioners in Guadeloupe, but no organized movement. Our ignorance of what is happening in English-speaking and Spanish-speaking countries is proportionate to the divisions established by five centuries of European rivalry in the Caribbean.

In conclusion, we can say that psychoanalysis exists in Martinique in spite of all. Changes coming from the

inside will probably ensure the development of fecund psychoanalytic thinking.

GUILLAUME SURÉNA

*See also:* Fanon, Frantz.

## MARTINS, CYRO (1908–1995)

Cyro Martins, a Brazilian psychoanalyst and full member and training analyst of the Psychoanalytic Society of Pôrto Alegre, was born on August 5, 1908, and died in Pôrto Alegre on December 15, 1995. He spent his childhood in Quaraí, where life was dedicated to farming. In 1920 at age eleven, he went to Pôrto Alegre to attend school and prepare for medical school, which he entered in 1928. Besides having an interest in medicine, from very early on Cyro proved to be a writer. When he was fifteen, he published his first short stories dealing with life in the country. “Influenced by friends and rural life, I wrote because of a personal feeling of disquiet,” he said, recalling his childhood and adolescence.

During his last year at medical school, Martins became interested in studying psychiatry. After medical school he returned to Quaraí, where he worked for three years, and in 1937 he went to Rio de Janeiro to study neurology and psychiatry. The following year he moved to Pôrto Alegre, where he began to work as a psychiatrist. From 1946 to 1948 he was an assistant instructor in neurology at the Pôrto Alegre Medical School.

In 1951 he and his friend Mário Martins went to Buenos Aires, where, at the Argentine Psychoanalytic Society, he concluded his psychoanalytic training. He was analysed by Arnaldo Rascowski, and his teachers included Angel Garma, Leon Grinberg, Enrique Pichon-Riviere, Arminda Aberastury, and Heinrich Racker. He was supervised by Pichon-Riviere and by Dr. Alvarez Toledo. In 1956 he returned to Pôrto Alegre and, together with Mário Martins, José Lemmertz, and Celestino Prunes, founded the Pôrto Alegre Center for Psychoanalytic Studies, the nucleus of the study group acknowledged by the International Psychoanalytical Association in 1961. In 1963 the center became the Psychoanalytic Society of Pôrto Alegre. Martins was president of the society from 1965 to 1969. He was also president of the first Brazilian Congress of Psychoanalysis, organized by the society. He represented

the society at various Brazilian congresses and was the official reporter on creativity at the Brazilian psychoanalytic congress held in Rio de Janeiro. Martins was a founding member of the Psychiatric Society of Pôrto Alegre and president for two successive terms. He was also a founder of the Society of Psychosomatic Medicine of Pôrto Alegre. As a consultant, he remained active and dedicated to the interests of the Psychoanalytic Society of Pôrto Alegre.

Martins wrote and published many papers, especially in the *Revista brasileira de psicanálise*. In 1964 he published the first book on psychoanalysis in Pôrto Alegre, *Do mito à verdade científica: Estudos psicanalíticos* (From myth to scientific truth: Psychoanalytic studies), a collection of his lectures and scientific papers presented at congresses.

A kind person who inspired respect and admiration, Martins died on December 15, 1995, in Pôrto Alegre.

GERMANO VOLLMER FILHO

*See also:* Brazil; Federación psicoanalítica de América latina.

## Bibliography

Martins, Cyro. (1964). *Do mito à verdade científica: Estudos psicanalíticos*. Rio de Janeiro, Brazil: Globo.

———. (1968). Regression in the analytic process: Transferential snapshot. *Revista brasileira de psicanálise*, 2, 191–197.

———. (1969). Sex identity disorders in Diadorim, a figure in the novel *Grande sertão: Veredas*. *Revista brasileira de psicanálise*, 3, 406–415.

———. (1973). *Perspectivas do humanismo psicanalítico*. Pôrto Alegre, Brazil: Sulina.

———. (1976). Contribution to the study of the history of psychoanalysis in Brazil. *Revista brasileira de psicanálise*, 10, 289–293.

———. (1994). Summary of history and relations with I.P.A. *Revista brasileira de psicanálise*, 28, 419–424.

Martins, Cyro, and Slavutzky, Abrão. (1990). *Para início de conversa*. Pôrto Alegre, Brazil: Movimento.

## MARTY, PIERRE (1918–1993)

Pierre Marty, a psychiatrist, psychoanalyst, member, and former president of the Société psychanalytique de Paris [Paris Psychoanalytic Society], was born on

March 11, 1918, in Saint-Céré, France, and died in Paris on June 14, 1993. He was considered the leading representative of the *École psychosomatique de Paris* (Paris School of Psychosomatics), whose work attracted a large international audience after the 1962 appearance of *La Pensée opératoire*, which he wrote with Michel de M'Uzan.

Marty spent his entire student life in a northern suburb of Paris, where his father was a teacher. During childhood and adolescence, the sickness of those closest to him caused him considerable distress. He claims that this was the origin of his interest in psychosomatics. After the lycée he began studying medicine, then psychiatry, and underwent personal analysis in 1947 with Marc Schlumberger. He married Simone Fain, the sister of Michael Fain, and the couple had one daughter, Catherine. Marty became a widower in 1963 and never remarried.

Marty quickly rose in the ranks of the SPP. Elected an associate member on June 20, 1950, he became a full member on May 20, 1952, and on January 20, 1953, Jacques Lacan, then president of the SPP, chose him as his secretary (a position he held until 1961). In this way Marty was able to directly follow the events that led to the split in the SPP, following the departure of Lacan and the founders of the *Société française de psychanalyse* (French Society for Psychoanalysis). Marty was an integral part of these events but he never wavered in his decision to remain within the SPP. He established solid ties to Sacha Nacht, Francis Pasche, Maurice Bouvet, and many others. Even at this time he had developed an interest in psychosomatics.

Secretary of the fifteenth *Congrès des psychanalystes de langues romanes*, held in November 1952, he closely followed these conferences, which enabled him to remain in contact with Spanish colleagues with whom he had shared his ideas and developed close friendships over the years. During the twenty-first *Congrès des psychanalystes de langues romanes*, held in Rome, he presented the paper “Dépersonnalisation et relation d’objet,” which Maurice Bouvet, who was then dying, was unable to present. Faithful to his friend, Marty was one of the founders and the “administrator” of the Maurice Bouvet Prize, created in 1962. Made vice president of the SPP in 1961, he became president of the organization in 1969. Throughout his tenure and through his activity, an “administrative board” was created by a vote on June 16, 1970, the first step toward in-depth reform of the bylaws and

structure of the SPP. This led to the direct participation of membership categories that had previously been excluded. Two years later, in 1972, Marty and Michel Fain created the *Institut de psychosomatique* (IPSO, Institute of psychosomatics), in Paris, where he continued to see patients. At IPSO there was a *Centre d’enseignement et de recherches en psychosomatique* (Center for Psychosomatic Teaching and Research), which over the years was to become a world-renowned center for training, research, and treatment.

Marty became interested in psychosomatics early in his career. On May 9, 1950, he presented, before the SPP, a paper, “Aspect psychodynamique de l’étude clinique de quelques cas de céphalalgie,” and he wrote the chapter “Clinique et pratique psychosomatiques” in *La Psychanalyse d’aujourd’hui*, a collection of essays edited by Sacha Nacht. With his description of “operative thinking,” followed by the publication of *L’Investigation psychosomatique* (1963), written with Michel de M'Uzan and Christian David, Marty discovered a new approach to clinical work: that of “operative” patients in whom there are only two possible outlets for non-mentalized excitation—behavior or the somatic path. But it was in his two most important books, *Les Mouvements individuels de vie et de mort* (1976) and *L’Ordre psychosomatique* (1980) that he best described his architectural and psychosomatic conception of human beings.

Starting from classical psychoanalytic theory and especially Freudian metapsychology, which remains the fundamental principle of mental organization, he expanded its theoretical-clinical model to the psychosomatic economy of subjects. Evolutionary and counter-evolutionary movements determine points of attachment on the central evolutionary chain, as well as on lateral and parallel chains. This led to the development of a new system of psychosomatic nosography, which placed, between neurotic structures and ongoing psychotic structures that are symptomatologically organized, fully conscious neuroses, inadequately mentalized or poorly mentalized neuroses, and behavioral neuroses. Diagnostic distinctions are made during the psychosomatic investigation through an understanding of the patient’s preconscious system. This new system of classification entailed an improved form of psychotherapy for patients whose “mentalization” seemed deficient. The “maternal function” of the analyst was then used in an attempt to “reactivate the relationship,” something at which Marty, a remarkable clinician, excelled.

The experience he acquired at the Poterne-des-Peupliers Hospital, now the Pierre Marty Hospital, where he was senior physician at the time of its creation in 1978, enabled him to establish the validity of his theoretical and clinical model. It appeared that mental work protected the body against somatic disorganization, regardless of its nature or form, and if this was already in place, it promoted reorganization through modifications of the psychosomatic economy that accompany engagement in a regular psychotherapeutic relationship. Originally conceived with adult patients in mind, this psychosomatic approach to human behavior was extended to adolescents, children, and infants. A children's unit has been in place at the Pierre Marty Hospital since its inception.

Marty's work has experienced, and continues to experience, widespread recognition in France and abroad. There are several Pierre Marty centers around the world.

ROSINE DEBRAY

*Notions developed:* Allergic-object reaction; Essential depression; Disorganization; Mentalization; Operational thought.

*See also:* Actual; Allergy; Asthma; Character neurosis; Psychic causality; Congrès des psychanalystes de langue française des pays romans; Conversion; Stranger; Excitation; Fixation; Disintegration, feelings of, (anxieties); France; Negative, work of; Actual neurosis/defense neurosis; Preconscious, the; Psychosomatic; Regression; Société psychanalytique de Paris et Institut de psychanalyse de Paris; Symptom-formation.

### **Bibliography**

Marty, Pierre. (1976). *Les mouvements individuels de vie et de mort* (Vol. 1, *Essai d'économie psychosomatique*). Paris: Payot.

———. (1980). *Les mouvements individuels de vie et de mort* (Vol. 2, *L'Ordre psychosomatique*). Paris: Payot.

———. (1990). *La psychosomatique de l'adulte*. Paris: Presses Universitaires de France.

Marty, Pierre, and M'Uzan, Michel de. (1962). La pensée opératoire. Intervention sur le rapport de M. Fain et Ch. David: Aspects fonctionnels de la vie onirique. XXIIIe Congrès des psychanalystes de langues romanes, Barcelone, 1962, *Revue française de psychanalyse*, 27, Spec. issue, 345–356.

## **MARXISM AND PSYCHOANALYSIS**

A priori, there seems to be nothing that would provide common ground between a theory of unconscious psychic processes, such as psychoanalysis, and a social theory such as Marxism. Nothing, that is, but that which derives as much from social processes as from psychic processes: the intellectual activity and beliefs of human beings. In *New Introductory Lectures on Psycho-Analysis* (1933), Sigmund Freud explicitly referred to Marxism. He did not dispute the fundamental validity of the theory, he merely considered it incomplete. If there are social conditions for the production of the intellectual, moral, and artistic activities of human beings, there are also psychological conditions that are independent of the former.

In the second generation of psychoanalysts, some authors, positioning themselves on the Left (within the social-democrat or communist movements), sought to constitute a social psychology by bringing Freudian analysis of psychic processes into articulation with Marxist analysis of social processes. This line of thinking has been called “Freudian Marxism,” despite its heterogeneity. Particularly productive during the 1920s and 1930s, this approach was notably illustrated by Wilhelm Reich, Siegfried Bernfeld, Erich Fromm, and Paul Federn.

In *The Dogma of Christ and Other Essays on Religion, Psychology, and Culture* (1930), Fromm sought to establish the factors that shaped the development of ideas about the relationship between God the Father and Jesus Christ up until the Nicene Council. The basis for the articulation is as follows: Marxist class theory provides the tools for analyzing the life conditions of the different social groups; on the basis of these conditions and the science of the unconscious, which sheds light on the frustrations and expectations of the believers, it becomes possible to describe the “psychic surface” of the persons involved in various events.

In “Dialectical Materialism and Psychoanalysis” (1929), Reich argued that if the instincts are biologically conditioned, they are also susceptible to change under the influence of environment and social reality. Social psychology studies the psychological characteristics shared by members of a group and the group's instinctual structure as a function of its “destiny”—that is, its economic and social situation. Reich wrote

*The Mass Psychology of Fascism* (1933/1946) in this same spirit. He again argued that the sexual poverty of human beings is mainly the result of their alienation by economic and social modes of production. *The Sexual Revolution, toward a Self-Governing Character Structure* (1936/1962) denounced the role of the family as “a factory for authoritarian ideologies and conservative structures” (p. 72), and in this work Reich denounced, as Fromm had done, the “patriarchal” system that prevails in our societies.

Work of this type was poorly received on the side of both psychoanalysis and Marxism. Nevertheless, Freudian Marxist research continued after World War II in Germany, with Alexander Mitscherlich (author of *The Inability to Mourn* and *Society without the Father: A Contribution to Social Psychology*) and the journal *Psyche*. During the same period, the Marxist-oriented philosophers of the Frankfurt Institute of Social Research became interested in psychoanalysis and tried their hand at bringing the two theories together with regard to ideology. Works such as *The Authoritarian Personality* (1950) by Theodor Adorno and collaborators marked this convergence.

In the United States, Herbert Marcuse, a former member of the Frankfurt School, published *Eros and Civilization: A Philosophical Inquiry into Freud* (1955). In this work he openly posed the question of happiness. He rejected Freud’s theory that civilization requires that the individual’s libido be sacrificed. Must happiness and the values of culture be antithetical? No, argued Marcuse. He attempted to show that libidinal repression does not take the same form in all cultures. He forged the concept of *surplus repression* to refer to that part of repression which is specific to a given culture and is not indispensable for group life.

During the 1970s there was renewed interest in the idea of bringing together Marxism and psychoanalysis, but on different bases. Jacques Lacan’s rereading of Freud, on the one hand, and Louis Althusser’s rereading of Marx, on the other, were relevant to this trend, not necessarily through direct influence, but by calling into question old stereotypes. Much of the work is being done in the early twenty-first century on belief systems, social representations, the ideal, or the *habitus* originated in this cultural ferment and bears its imprint, although it is more accurate to speak in terms of multireferentiality rather than of “synthesis.”

MICHÈLE BERTRAND

See also: Althusser, Louis; *Anti-Oedipus: Capitalism and Schizophrenia*; Bernfeld, Siegfried; Caruso, Igor A.; Detski Dom; Fenichel, Otto; France; Fromm, Erich; Ideology; Marcuse, Herbert; *Mass Psychology of Fascism*, The; Morgenthau, Fritz; Philosophy and psychoanalysis; Politics and psychoanalysis; Politzer, Georges; Reich, Wilhelm; Rittmeister, John Friedrich Karl; Russia/USSR; Sociology and psychoanalysis, sociopsychanalysis; Surrealism and psychoanalysis; *Weltanschauung*.

### Bibliography

- Fromm, Erich. (1963). *The dogma of Christ and other essays on religion, psychology, and culture*. New York: Henry Holt. (Original work published 1930)
- Marcuse, Herbert. (1955). *Eros and civilization: A philosophical inquiry into Freud*. Boston: Beacon.
- Mitscherlich, Alexander. (1974). *Society without the father: A contribution to social psychology* (Erick Mosbacher, Trans.). New York: J. Aronson. (Original work published 1964)
- Reich, Wilhelm. (1972). Dialectical materialism and psychoanalysis. In *Sex-pol; essays, 1929–1934* (Anna Bostok, Tom DuBose, and Lee Baxandall, Trans.). New York: Random House. (Original work published 1929)

---

## MASCULINE PROTEST (INDIVIDUAL PSYCHOLOGY)

Masculine protest is a concept described by Alfred Adler. In women it gives expression to a rejection of their feminine condition, the consequence of a devalorization of girls in their family or cultural milieu and the choice of a masculine ideal in the formation of their guiding fiction. In men it expresses itself as a superiority complex.

In *Social Interest: A Challenge to Mankind* (1933/1938), Alfred Adler wrote: “When a girl imagines that she can change into a boy, it is because the feminine role has not been presented to her as the equal of the masculine role. She revolts against what she believes to be a permanent perspective of inferiority for her. The Freudians have interpreted this fact as what they call the ‘castration complex.’” This rejection of the feminine role is also the consequence of the mother’s preference for her son or sons, which constitutes a paradox. Writing about one of his patients, Adler said: “Her mother, a fact that is unfortunately very frequent, had more affection for her sons than for her daughter, which confirms that she also accorded greater value to the male principle without, however, giving her husband the advantage that is inherent in this mode of

appreciation” (Adler, 1912/1926). This decathexis of the father facilitates father-daughter alliances. This patient had become the absolute mistress of the house. Speaking of another patient, he commented: “In her childhood antecedents we find a powerful feeling of inferiority, maintained in a constant state of tension by the fact that her mother preferred her younger brother and that he was more intelligent than she was. This patient’s most ardent conscious desire was always to be tall, very intelligent, to be a man.”

A conflictual relationship with the mother exacerbates the need to compensate against the inferiority complex through the elaboration of an ideal virile model and leads to a hostile attitude to women. Sexual and aggressive instincts then come together either in masculine behavior that rivals with men or in homosexual behavior where a dominant role is assumed. When the woman becomes a mother herself, she can transpose these problems to her relations with her children, as described by Adler in the following case: “Her attitude of rivalry with regard to her daughter was completely unconscious and might be said to act as a cover for an infantile attitude: the desire to surpass a sister that her parents had spoilt to the point of excess. But this latter attitude proved in turn to be equivalent to the fundamental attitude, namely her desire to acquire greater importance, to occupy her brother’s position” (Adler, 1912/1926).

For Adler the organization of the Self is indissociable from the history of the subject and the subject’s culture. As he wrote in *Understanding Human Nature*: “In civilization every woman wants to be a man” (1927/1992). The choice of a son to express this masculine protest could encourage delinquent or transsexual behavior. Social feeling plays an essential role in the socialization of such behaviors, or indeed their sublimation. In men, masculine protest becomes manifest in the cult of the superman, wherein human feelings are considered to be a sign of feminine weakness.

FRANÇOIS COMPAN

*See also:* Analyzability; Biological bedrock; Castration complex; Change; Femininity, rejection of; Masculinity/femininity; Narcissism; “On the History of the Psychoanalytic Movement”; Penis envy; Primary narcissism.

### **Bibliography**

Adler, Alfred. (1926). *The neurotic constitution; Outlines of a comparative individualistic psychology and psychotherapy.*

(Bernard Glueck and John E. Lind, Trans.). New York: Dodd, Mead. (Original work published 1912)

———. (1938). *Social interest: A challenge to mankind.* London: Faber and Faber. (Original work published 1933.)

———. (1979). *Superiority and social interest: A collection of later writings* (Heinz L. Ansbacher and Rowena R. Ansbacher, Eds.). New York: Norton.

———. (1992). (1) *Understanding human nature* (Colin Brett, Trans.). Oxford: Oneworld. (Original work published 1927)

---

## **MASCULINITY/FEMININITY**

The feeling of belonging to a gender, masculine or feminine, has different meanings: first, a biological meaning that refers to primary and secondary sexual characteristics; second, a sociological meaning that has to do with the real and symbolic roles that society attributes to men and women; and finally, a psychological meaning that considers the ensemble of traits belonging to either gender.

As early as 1897, in his correspondence with Wilhelm Fliess, Sigmund Freud showed interest in the masculine/feminine dichotomy from two different, complementary perspectives: that of bisexuality and that of psychosexual development. He continued his study in “Three Essays on the Theory of Sexuality” (1905d), and then further refined his thinking in an article, “Feminine Sexuality” (1931b) and in lecture 33, “Femininity,” in his “New Introductory Lectures on Psycho-Analysis” (1933a [1932]).

Freud upheld the notion of a bisexuality that involves, in every human being, a more or less harmonious and more or less accepted synthesis of masculine and feminine traits. In developing his hypotheses, he was unable to relinquish the idea of biological bisexuality, even though he attributed a dominant role to the interplay of oedipal and preoedipal identifications.

In Freud’s view, the opposition between masculinity and femininity is preceded by other pairs of opposites—active/passive, phallic/castrated—that pave the way for it. Furthermore, in his view femininity does not appear until after the reorganization of the psyche that occurs at puberty. This conception of masculinity and femininity comes from the fact that Freud based his theory of sexuality on the prevalence of the phallus for both sexes. The opposition between masculinity

and femininity thus tends to become blurred, since both sexes are united in the same repudiation of a femininity that is equated with being deprived of the penis. Only masculinity is identifiable; femininity can only be understood in terms of the negative. Its development remains vulnerable to disturbances resulting from the after-effects of the earlier masculine period—that is, the regressions and fixations of the preoedipal stage. Freud thus envisioned the masculine/feminine dichotomy as an alternation of periods in which one or the other of the elements has the upper hand, including the libido, which pursues masculine or feminine aims in sexual life.

Freud himself acknowledged that he was not entirely at ease in his approach to the questions of feminine sexuality and bisexuality. He has often been criticized in this area, notably with regard to his equation of femininity with passivity. Currently, psychoanalytical studies of gender identity and early parent-child interactions have made possible a better understanding of the relationships between masculinity and femininity and their origins.

Masculinity and femininity are rooted in the intimacy of the earliest interactive bonds between parents and the child. The processes of “psychobisexualization,” a term introduced by Christian David, are established very early on, based on the child’s instinctual oppositions, which are modulated by the adaptive capacities of the mother and father. Each parent presents to the child his or her own opposition between masculine and feminine, in a manner that differs according to the baby’s sex. This abundance of interactive material further informs the oppositions already active within the infant (presence/absence, active/passive, phallic/castrated, good/bad), paving the way for the masculine/feminine opposition, which only appears, as such, in the oedipal stage.

Other authors have considered the question from the more archaic perspective of psychic envelopes, which also contain a dichotomy capable of grounding the opposition between masculine and feminine.

In any case, it is the baby that solicits the parents in one register or another, and not necessarily the father in his masculine aspects or the mother in her feminine aspects. The father and the mother, through regressive identifications, enter into communication with the child, incorporating varying amounts of their own masculine and feminine components. The child discovers the difference between the sexes within these

interrelationships and internalizes, in variable proportions, the ensemble of both masculine and feminine components, to establish the basic framework of his or her own psychic bisexuality.

Masculinity and femininity are situated at the crossroads of, on the one hand, interactions in the here and now, and on the other, maternal and paternal transgenerational filiations.

PHILIPPE METELLO

*See also:* Activity/passivity; Castration complex; “Claims of Psycho-Analysis to Scientific Interest”; Conflict; Dark continent; Female sexuality; Feminine masochism; Femininity; Femininity, rejection of; Feminism and psychoanalysis; Gender identity; Homosexuality; “New Introductory Lectures on Psycho-Analysis”; Penis envy; Perversion; Phallic stage; Phallic woman; *Psychology of Women, The. A Psychoanalytic Interpretation*; Real, Symbolic, and Imaginary father; “Some Psychical Consequences of the Anatomical Difference between the Sexes”; Termination of treatment.

### **Bibliography**

- Chiland, Colette. (1999). *Le sexe mène le monde*. Paris: Calmann-Lévy.
- David, Christian. (1975). La bisexualité psychique, élément d’une réévaluation. *Revue française de psychanalyse*, 39 (5–6), 713–856.
- Freud, Sigmund. (1931b). Feminine sexuality. *SE*, 21: 221–243.
- . (1933a [1932]). New introductory lectures on psycho-analysis. *SE*, 22: 1–182.
- . (1950a [1887–1902]). Extracts from the Fliess papers. *SE*, 1: 173–280.

---

## **MASOCHISM**

Masochism is a form of pleasure obtained through suffering. The term was initially defined by Kraft-Ebbing in his book on sexual perversion, and is derived from the name of the author of *Venus in Furs*, Leopold von Sacher-Masoch. Initially considered by Freud as one of the infantile polymorphous perversions present in all human beings, masochism was associated with its opposite, sadism, with which it is generally paired. Although Freud originally saw masochism as deriving from sadism, he reversed this conception with the introduction of the second theory of drives: masochism became primary, the initial fusion of the death

instinct with the life instinct, protecting the human being from the self-destruction toward which the death instinct drove it.

In *The Interpretation of Dreams* (1900a), Freud, referring to a bunch of violets present in a dream, identified, through association with the English term *violation*, a masochistic character trait in the dreamer. In a 1909 note he refers to unpleasant dreams as satisfying masochistic functions. In *The Psychopathology of Everyday Life* (1901b), Freud for the first time makes a parallel between the hysterical fantasies of sexual cruelty, delusions of persecution (of which Judge Schreber was an illustration), and the deviant behavior perverts engaged in to satisfy their desires.

In his *Three Essays on the Theory of Sexuality* (1905d), Freud remarked (in a note added in 1910) that the masochistic component of sexual instinct allowed the subject to form an unconscious fixation on the figure of the hypnotist, which accounts for the hypnosis. He then described sadism and masochism, the latter always being derived from the first through a process of reversal—the subject becomes object. Masochism is associated with passivity and sadism with activity. An essential characteristic of the perversions is that the active and passive forms are found in the same individual. Since neurosis is the “negative of perversion,” this holds true for every human being. It is the anal-sadistic pregenital phase that clearly reveals the opposition between active and passive, a precursor of the later opposition between masculine and feminine. “The skin functions as an erotogenic zone in the component sexual instincts,” and one of the infantile erogenous sources of masochism is the “painful stimulation of the skin of the buttocks” (1905d, p. 193), a phenomenon that has been well known since the *Confessions* of Jean-Jacques Rousseau. In the *Three Essays* Freud describes libidinal coexcitation, prefiguring what would become erotogenic masochism in 1924.

“Instincts and Their Vicissitudes” (1915c) provides the first full Freudian description of masochism, which is derived from sadism turning back upon itself. First it turns back on the individual—the subject takes the place of the object—then activity turns into passivity. The pair of opposites that is formed is compared to another pair—voyeurism and exhibitionism. Freud, however, must address the following difficulty: although the child’s first aggressive acts are directed only at inflicting pain and are associated with self-preservation, he is logically led to consider that it is

only when the subject has become capable of reversing his masochism that he can become truly sadistic. Once this component of sexual excitation has been confirmed, the “pains inflicted on other people [can be] enjoyed masochistically by the subject through his identification of himself with the suffering object” (p. 129). There is an even greater satisfaction: The sadist can enjoy the sexual excitation associated with pain without experiencing pain himself. Freud resolves this contradiction with a temporal paradox where two originals are postulated, entailing a strange process of deferral: “The enjoyment of pain would thus be an aim which was originally masochistic, but which can only become an instinctual aim in someone who was originally sadistic” (p. 129).

In “A Child is Being Beaten” (1919e), Freud discusses the “genesis of masochism”. This appears to be based on clinical material drawn in part from Freud’s analysis of his daughter Anna. Freud maintains there is an initial period of sadism, with a growing tendency toward masochism. Masochism is described as participating in fantasy and autoeroticism, in the repression of oedipal jealousy. Expanding a child’s fantasy of punishment, Freud reveals the presence of an oedipal jealousy satisfied through sadism that leads, during a second stage, to a masochistic reversal, which remains unconscious under the influence of guilt: to be beaten by the father. The third stage—that of fantasy—whose protagonists have become anonymous, is sadistic only in appearance; the pleasure is in fact masochistic.

In *Beyond the Pleasure Principle* (1920g) Freud notes (in a passage added in 1921) that a traumatic dream could reveal “the mysterious masochistic trends of the ego” (p. 14). For the first time he sees that “there *might* be such a thing as primary masochism could also be primary” (p. 55). He then connects the negative therapeutic reaction to the feeling of unconscious guilt and its satisfaction through experiencing suffering as punishment.

It is in “The Economic Problem of Masochism” (1924c) that Freud describes his second theory of masochism, now adjusted to accommodate the second topographical subsystem and the new duality of drives that accompanies it: the death and life instincts. Masochism is broken down into erogenous masochism (pleasure in pain), feminine masochism (the expression of the female component in both sexes), and moral masochism (behavior associated with the



unconscious feeling of guilt)—the latter two expressions being based on the former.

Original erogenous masochism, or primary masochism, enables the libido's initial control of the death instinct within the individual, thus protecting him from destruction. One part of the death instinct is diverted outward by the libido, giving birth to destructive drives, drives of control, and sadistic drives, by putting it at the service of the sexual function. The other part, which remains within the organism, is bound through libidinal coexcitation; this is the original erogenous masochism. While masochism can, like a "drug" of self-preservation, lead the human being toward death, it is also a means for the libido to bind and thereby contain the death instinct and protect it from self-destruction.

Freud would maintain this model throughout his work and in "Analysis, Terminable and Interminable" (1937c) insisted on the role of masochism in the need for punishment, in the unconscious feeling of guilt in the resistance to treatment, and in the negative therapeutic reaction, thus providing a foothold for modern theorizations of these fundamental problems.

The evolution of Freud's theory of masochism is an integral part of his need to conceptualize a second theory of instincts, "beyond the pleasure principle," and recenter masochism as the foundation of the human psyche.

Benno Rosenberg has insisted on masochism's role as a "guardian of life," promoting survival under extreme external conditions, and as an internal organizer of the psyche. This conception makes masochism a primary kernel of the ego. By emphasizing the "internal" capacity of the psyche to fuse the life and death instincts, and thus organize itself, it contradicts theorizations that promote an external genesis for drives, whether this is reflected in the structuralism promoted by Jacques Lacan, the generalized seduction of Jean Laplanche, or the claims of "object relations" theory. Lacan was not unaware of erogenous masochism, which he referred to as "jouissance." Similarly, in the case of female femininity and maternity, female masochism served as a powerful impetus for the ego.

Karl Abraham and Melanie Klein made extensive use of the concept of sadism in their treatment of sado-masochism. For Klein, who agreed with Freud's formulation of the second theory of drives, sadism soon came to embody the destructiveness of the death

drive, which can be compared to the prevalence and precocity of projection in her theorization.

Edmund Bergler provided an original contribution to the theory of masochism, which he felt played an early, and significant, role in the development of libidinal stages. His theory of what he termed *basic neurosis* was based on oral masochism, the underlying structure for all other mental structures.

DENYS RIBAS

*See also:* Activity/passivity; Aggressiveness/aggression; Anorexia nervosa; *Basic Neurosis, The—Oral Regression and Psychic Masochism*; *Character Analysis*; Conflict; Cure; Death instinct (Thanatos); Demand; Desexualization; Dismantling; "Dostoyevsky and Parricide"; Erotogenicity; Erotogenic masochism; Eros; Eroticism, oral; Ethics; Failure neurosis; Feminine masochism; Femininity; Feminism and psychoanalysis; Fort/Da; Fusion/defusion; Fusion/defusion of instincts Guilt, unconscious sense of; Hypochondria; *Instincts and their Vicissitudes*; Moral masochism; "Mourning and Melancholia"; Need for punishment; Negative therapeutic reaction; Negative, work of; Nirvana; Orality; Orgasm; Pain; Pairs of opposites; Perversion; Pleasure/unpleasure principle; Primary masochism; Punishment, dream of; Quantitative/qualitative; Self-hatred; Self-mutilation in children; Self-punishment; Skin; Subject of the unconscious; Subject's castration; Superego; Transference hatred; Turning around; Turning around upon the subject's own self.

### Bibliography

- Bergler, Edmund. (1949). *The basic neurosis—oral regression and psychic masochism*. New York: Grune and Stratton.
- Freud, Sigmund. (1905d). Three essays on the theory of sexuality. *SE*, 7: 123–243.
- . (1915c). Instincts and their vicissitudes. *SE*, 14: 109–140.
- . (1924c). The economic problem of masochism. *SE*, 19: 155–170.
- Rosenberg, Benno. (1991). *Masochisme mortifère et masochisme gardien de la vie*. Paris: Presses Universitaires de France.

---

## MASS PSYCHOLOGY OF FASCISM, THE

As Wilhelm Reich notes, his *The Mass Psychology of Fascism* "was thought out during the German crisis years, 1930–33. It was written in 1933; the first edition

appeared in September of 1933 and the second edition in April of 1934, in Denmark” (1970b, p. xvii). A genuinely burning question lay at the heart of the book: How did Hitler succeed in imposing himself? More specifically, how could a people of seventy million cultivated, hardworking individuals let themselves be seduced by a manifest psychopath? Even beyond the period when it was formulated, which culminated in horror, this question is surely still fundamental to any serious political thinking.

As a militant well versed in Marxism and the author of “Dialektischer Materialismus und Psychoanalyse” (Dialectical materialism and psychoanalysis; 1970a), Reich set out to analyze “the economic and ideological structure of German society between 1928 and 1933.” He wanted to illuminate the state of mind of the middle classes and the petite bourgeoisie. Their frustrations, resentments, fears, envies, and hatreds together formed what Reich called an “emotional plague,” which found release and gratification in the themes and imagery pounded out by Nazi propaganda and ideology.

Reich denounced the authoritarian family (which he described as “antosexual,” as a “central, reactionary cell”); strict, repressive education (which oppressed and subjugated the individual); nationalistic feelings; and religious indoctrination—all fertile ground, he argued, for sanctifying a charismatic leader brandishing obscure myths of blood, race, and soil in mystical defiance of human reason.

In Reich’s view, the symbolism of the swastika, evoking the fantasy of the primal scene (and reproduced hundreds of thousands of times), showed in spectacular fashion how Nazism systematically manipulated the unconscious. A repressive family, a baneful religion, a sadistic educational system, the terrorism of the party, and economic violence all operated in and through individuals’ unconscious psychology of emotions, traumatic experiences, fantasies, libidinal economies, and so on, and Nazi political ideology and practice exacerbated and exploited these tendencies. This unconscious mental dimension was still beyond the ken of traditional politicians, whether liberal or communist, and this ignorance led them to failure and disaster.

For Reich, fighting fascism meant first of all studying it scientifically, which was to say, using the methods of psychoanalysis. Reason, alone able to check the forces of irrationality and loosen the grip of mysticism, is also

capable of playing its own part in developing original modes of political action, building on a deep respect for life, and promoting a harmonious channeling of libido and orgasmic potency. Reich proposed “work democracy,” a self-managing form of social organization that would preserve the individual’s freedom, independence, and responsibility and base itself on them.

ROGER DADOUN

*See also:* Collective psychology; Marxism and psychoanalysis; Politics and psychoanalysis; Reich, Wilhelm.

### Source Citation

Reich, Wilhelm. (1946). *The mass psychology of fascism* (Theodore P. Wolfe, Trans.). New York: Orgone Institute; (1933). *Die Massenpsychologie des Faschismus*. Copenhagen/Prague/Zurich: Verlag für Sexualpolitik.

### Bibliography

Dadoun, Roger. (1986). La psychologie de masse du fascisme. In Olivier Duhamel, François Châtelet, and Évelyne Pisier (Eds.), *Dictionnaire des œuvres politiques*. Paris: Presses Universitaires de France.

Reich, Wilhelm. (1970a). Dialektischer Materialismus und Psychoanalyse. In Siegfried Bernfeld (Ed.), *Psychoanalyse und Marxismus*. Frankfurt am Main, Germany: Suhrkamp. (Original work published 1929.)

———. (1970b). *The mass psychology of fascism* (Vincent R. Carfagno, Trans.). New York: Farrar Straus Giroux.

---

## MASTERY

The term *mastery* has several meanings in psychoanalysis. The first relates to the anal stage in infantile sexual development, as Sigmund Freud described it in *Three Essays on the Theory of Sexuality* (1905d). During this period in the structuring of the personality, the child is becoming better able to exercise muscular control over fecal contents and finds pleasure in the actions of retention and defecation. In “‘Civilized’ Sexual Morality and Modern Nervous Illness” (1908d) Freud described three characteristics of the anal stage: order, economy, and obstinacy. All three are marked by mastery, and they result from the sublimation of anal erotism.

It must be noted that anal erotism and mastery of its concomitant excitation are articulated with the loss of an object that is an integral part of the body. The

function of mastery thus has to do with the excitation produced in the anal zone at the very moment of defecation and the possible perception of a part of the body that becomes detached from the whole. Anal erotism is commonly associated with sadism and aggressivity: Mastery over an object can be understood as the psychic correspondent to control of the sphincter. Some types of depression can be linked to feelings of powerlessness resulting from an inability to exercise complete control over the inevitable separation from the object. The symbolic equivalency between feces, gifts, and money demonstrated by Freud makes it possible to see, throughout this chain, the importance of phenomena of mastery in gifts, indebtedness, and exchanges.

On the level of fantasy, an expression of mastery is found in fantasmatic scenarios constructed around beating or being beaten, typified by “A Child Is Being Beaten: A Contribution to the Study of the Origin of Sexual Perversions” (1919e). The analysis of this fantasy proposed by Freud reveals an unconscious wish to be beaten by the father and refers to the satisfaction—initially masochistic and secondarily sadistic—of this fantasmatic constellation. The fantasy suggests an appeal to a cruel superego that ensures mastery over the ego yet simultaneously procures enjoyment (*jouissance*) for it. The terms *master* and *mistress* in the erotic tradition foregrounded by Leopold von Sacher-Masoch represent mastery’s perverse dimension.

It is worthwhile to establish a conceptual distinction between *mastery* and *dominance*. Mastery is more specifically aimed at excitation, whereas in Freudian theory, dominance has the status of an instinct that specifically involves an object or part-object.

Following Roger Dorey in “La relation d’emprise” (1981; The dominance relationship), it can be said that mastery involves and presupposes a relative recognition of alterity as well as a certain renunciation of the object. But this notional differentiation, while essential, is not easy to establish in clinical practice, since fantasies of seduction and beatings express in paradoxical ways the effects of both dominance and mastery. It is thus appropriate to consider the specific allocation, for each individual, of the processes of dominance aimed at conservation of the object and the processes of mastery of excitation that make it possible to maintain new cathexes and identifications. And indeed, it is the perennial nature of the identificatory project that attests to the efficacy of mastery: It is

constitutive of the nature of identification, which is always being reshaped into new formations while maintaining the narcissistic quest for domination, although this quest is hidden.

The assurance of mastery involves the ego itself in its relation to the world: Integrating the requirements of the ego ideal, it makes the ego’s identificatory project a process that is simultaneously continuous and differentiated. The ego ideal serves as a relay between the subject and his or her community, which serves as a symbolic model in terms of the taboos against murder and incest. The community exerts a mastery to which the subject is submitted, and which the subject must appropriate to signify their membership in the human community.

Finally, it is appropriate to situate the notion of mastery at the very heart of analytic technique. The rules of free association and free-floating attention are fundamental and paradoxical from the point of view of mastery. They indicate a pathway that, at first view, entails letting go of conscious mastery in order to make possible the resurgence of the primary processes that enable unconscious formations to pass into the preconscious. They are also rules of a type of mastery that is specific to the psychoanalytic process, on the part of both analyst and analysand, allowing unconscious representations and affects to be elicited. The issue of mastery in relation to the analyst’s countertransference is essential here in order to limit countertransference projection, seduction, or even abuse, so that the analysand can be heard in their authentic relationship to their own unconscious truth.

MARC BONNET

*See also:* Anal-sadistic stage; Civilization (Kultur); Conscious processes; Encopresis; Eroticism, anal; Face-to-face situation; Judgment of condemnation; Manic defenses; Mastery, instinct for; Mirror stage; Protective shield, breaking through the; Sadism; Symbolization, process of; Termination.

### **Bibliography**

- Dorey, Roger. (1981). La relation d’emprise. *Nouvelle Revue de psychanalyse*, 24, 117–140. (Reprinted in *Le Désir de savoir*, Paris: Denoël, 1988.)
- Freud, Sigmund. (1905d). Three essays on the theory of sexuality. *SE*, 7: 123–243.
- . (1908d). “Civilized” sexual morality and modern nervous illness. *SE*, 9: 177–204.

———. (1919e). A child is being beaten: A contribution to the study of the origin of sexual perversions. *SE*, 17: 175–204.

Guillaumin, Jean. (1983). *Psyché*. Paris: Presses Universitaires de France.

## MASTERY, INSTINCT FOR

The expression *instinct for mastery* refers to an instinct whose aim is the appropriation of the object. For Sigmund Freud, this is a nonsexual form of instinct that can be blended with the sexual instincts. The introduction of this concept within the evolution of Freudian theory is representative of an early stage of the concept of the dualism of the instincts.

The instinct for mastery first appears in Freud's *Three Essays on the Theory of Sexuality* (1905d), where it is initially included in the evocation of a *Bemächtigungsapparat*, or apparatus for mastery, and later under its direct name of *Bemächtigungstreib*. There are seventeen occurrences in Freud's work from 1905 to 1933.

This instinct has a central place in the “Three Essays on the Theory of Sexuality” in that Freud places it in the service of the satisfaction of hunger and sexual needs and posits that sadism derives from it. The elements of the apparatus for mastery must be deduced from Freud's text; these include the sense of touch, the muscular apparatus, and the sensory organs in general. “The activity is put into operation by the instinct for mastery through the agency of the somatic musculature” (p. 198), he writes. The muscles of the body thus appear as the agent of mastery; the hand, whose movements involve the sense of touch and the musculature working in tandem, is thus an essential organ of the apparatus for mastery.

Freud clearly indicates the role of the instinct for mastery as it serves the sexual needs: “A certain amount of touching is indispensable (at all events among human beings) before the normal sexual aim can be attained” (p. 156). Moreover, in connection with masturbation: “The preference for the hand which is shown by boys is already evidence of the important contribution which the instinct for mastery is destined to make to masculine sexual activity” (p. 188).

He links the instinct for mastery and its derivatives—cruelty, the pleasure of looking, and the pleasure of showing—to bodily functions “that appear in a

sense independently of erotogenic zones” (p. 192) or even in the case of cruelty “independently of the sexual activities that are attached to erotogenic zones” (p. 193). He further links the instinct for mastery to the “instinct for knowledge,” which “cannot be counted among the elementary instinctual components, nor can it be classed as belonging exclusively to sexuality. Its activity corresponds on the one hand to a sublimated manner of obtaining mastery, while on the other hand it makes use of the energy of scopophilia” (p. 194).

The link between the instinct for mastery and cruelty is explained in a way that prefigures the notion of instinctual blends: “The sexuality of most male human beings contains an element of aggressiveness—a drive to subjugate; the biological significance of it seems to lie in the need for overcoming the resistance of the sexual object by means other than the process of wooing. Thus sadism would correspond to an aggressive component which has become independent and exaggerated and, by displacement, has usurped the leading position” (pp. 157–158).

The instinct for mastery thus begins to change in its status in Freud's work; it starts to appear more as an intermediary concept between the sexual and the nonsexual than as a conceptual pole that can be opposed to the sexual. In his subsequent search for a dualism that is more clearly grounded in biology, Freud relegates the instinct for mastery to the background, preferring to focus instead on the notion of self-preservation instincts as the polar opposite of the sexual instincts (“Notes Upon a Case of Obsessional Neurosis” [1909d]). The instinct for mastery nevertheless retains a place in “Instincts and Their Vicissitudes” (1915c), but finally, from about 1920, in the dualism that pits the life instincts against the death instincts, the instinct for mastery is viewed as merely a derivative of the latter.

Long neglected by theorists, the instinct for mastery returned to prominence in psychoanalytic thought only with the publication of Jean Laplanche and Jean-Bertrand Pontalis's article on it in their *Vocabulaire de la psychanalyse* (1967). Roger Dorey (1981) discusses it in the context of the “mastery relationship”; Jean Bergeret uses the Freudian concept of the instinct for mastery as his point of departure in his development of the notion of “fundamental violence”; Jean Gillibert (1982) describes it as the “drive's drive” behind destruction, the result of “madness for mastery”; and

Paul Denis (1992) proposes to reconsider the theory of the drives beginning with the hypothesis that the drives themselves, in their constituent organization, bring together a “formative component of mastery” and a “formative component of satisfaction,” whose economic weight can vary and whose dissociation can be observed.

PAUL DENIS

*See also:* Cruelty; Hatred; Knowledge or research, instinct for; Libidinal development; Lost object; Mastery; Pleasure in thinking; Sadomasochism; *Three Essays on the Theory of Sexuality*.

### **Bibliography**

- Denis, Paul. (1992). Emprise et théorie des pulsions. *Revue française de psychanalyse*, 56 (5), 1295–1421.
- Dorey, Roger. (1981). La relation d’emprise. *Nouvelle Revue de psychanalyse*, 24, 117–140.
- Freud, Sigmund. (1905d). Three essays on the theory of sexuality. *SE*, 7: 135–243.
- . (1909d). Notes upon a case of obsessional neurosis. *SE*, 10: 155–318.
- . (1915c). Instincts and their vicissitudes. *SE*, 14: 109–140.
- Gillibert, Jean. (1982). De l’objet pulsionnel de la pulsion d’emprise. *Revue française de psychanalyse*, 46 (6), 1211–1244.
- Laplanche, Jean, and Pontalis, Jean-Bertrand. (1974). *The language of psychoanalysis* (Donald Nicholson-Smith, Trans.). New York: Norton. (Original work published 1967)

## **MASTURBATION**

Masturbation is the act of obtaining pleasure from manipulation of the genital organs.

Before Sigmund Freud shed light on infantile sexuality, masturbation was exclusively viewed from the extremely negative perspective of religion and morality, rather than being seen as a social and medical problem. This is attested by Dr. Samuel Auguste David Tissot’s *L’onanisme: Dissertation sur les maladies produites par la masturbation* (Onanism: Dissertation on the illnesses produced by masturbation; 1778), which for more than a century and a half remained the standard reference on the issue. In 1576 Michel de Montaigne, in his *Essays* (II, 12), was the first to introduce the term *masturbation* into the French language; its

etymological origins are controversial. In 1835 the word appeared in the sixth edition of the dictionary of the French Academy, where *onanism* was given as a synonym.

In his *Three Essays on the Theory of Sexuality* (1905d), Freud defined masturbation as an infantile sexual activity, an autoerotic practice whose erotogenic zone is the genital region. During the child’s development, most of the other erotogenic zones lose their importance and are subordinated to the genital zone. Within psychoanalytic theory, Freud gave a central place to masturbation, specifying in a note added to the same text in 1920 that “masturbation represents the executive agency to the whole of infantile sexuality and is, therefore, able to take over the sense of guilt attaching to it” (1905d, p. 189, n. 1). He placed the three phases of infantile masturbation at the period when the infant is nursing, at four years of age, and at puberty.

René Spitz held that autoerotic activity in the form of playing with the genitals during the first eighteen months of life is a good indicator of appropriate object relations, just as appropriate sexual activity is in the adult. Melanie Klein always placed great importance on masturbatory fantasies, arguing that these indirectly feed into most activities of the normal child, such as play and schoolwork.

The reactions of caregivers to the child’s masturbatory behaviors play a part in structuring the child’s personality. In the case of the “Wolf Man,” presented in “From the History of an Infantile Neurosis” (1918b [1914]), Freud explained that within the childhood nodal complex, in the realm of sexual relations the father takes on the role of the enemy: the person who interferes with autoerotic sexual activity. Spitz showed that this restriction of sexuality, masturbation in particular, allows for social and civilized attainments such as the superego in humans.

Freud insisted on the infantile aspect of masturbation, and this topic became controversial at a 1910 meeting of the founders of the Vienna Psychoanalytic Society to discuss “the harmful effects of masturbation” (Nunberg and Federn, 1962–1975). From this it was wrongly extrapolated that masturbation in adults is regressive and should be viewed as psychopathological. It should be stressed that masturbation in adults, within the framework of an object relation, is a normal expression of adult sexuality. Hence, it is to be distinguished from infantile autoerotism, which, if it persists

into adulthood, is considered a sign of neurosis or perversion.

FRANCK ZIGANTE

*See also:* Actual neurosis/defense neurosis; Alcoholism; Autoeroticism/alloeroticism; Castration complex; Drug addiction; Erythrophobia (fear of blushing); Female sexuality; “Heredity and the Aetiology of the Neuroses”; Jouissance (enjoyment); Latency period; Mastery, instinct for; Neurasthenia; Preenatal; Rite and ritual; “Some Psychological Consequences of the Anatomical Distinction between the Sexes”; Tics; *Three Essays on the Theory of Sexuality*.

### **Bibliography**

Brenot, Philippe. (1997). *Éloge de la masturbation (Grain d'orage)*. Cadeilhan, France: Zulma.

Freud, Sigmund. (1905d). Three essays on the theory of sexuality. *SE*, 7: 123–243.

———. (1918b [1914]). From the history of an infantile neurosis. *SE*, 17: 1–122.

Lebovici, Serge, and Soulé, Michel. (1970). *La connaissance de l'enfant par la psychanalyse*. Paris: Presses Universitaires de France.

Nunberg, Hermann, and Federn, Ernest. (1962–1975). *Minutes of the Vienna Psychoanalytic Society*. New York: International Universities Press.

Spitz, René A. (1964). Vers une réévaluation de l'autoérotisme. *Psychiatrie de l'enfant*, 7, 269–297.

Tissot, Samuel Auguste David. (1778). *L'onanisme: Dissertation sur les maladies produites par la masturbation* (5th ed.). Lausanne.

### **Further Reading**

Arlow, Jacob. (1953). Masturbation and symptom formation. *Journal of the American Psychoanalytic Association*, 1, 45–58.

Isay, Richard A., rep. (1980). Panel: Adult masturbation: Clinical perspectives. *Journal of the American Psychoanalytic Association*, 28, 637–652.

Reich, Annie. (1951). The discussion of 1912 on masturbation and our present-day views. *Psychoanalytic Study of the Child*, 6, 80–94.

## **MATERNAL**

*Maternal* refers to the physical and psychological care given to another person on the model of a needy

infant. For Freud ever since the *Project for a Scientific Psychology* (1950c [1895]), the ambiguity of the maternal for the infant was inherent in its ambiguous nature: breast-object or person-mother, total/partial, satisfying needs (mixed with the quality of care dispensed and the sensations procured), internal/external, protective shield/seduction.

Freud isolated an essential component in these dualities: the care associated with the protective shield and intended to satisfy needs also awakens partial sexual drives in the erotogenic zones. Supported by the self-preservation drives, they manifest themselves in autoeroticism. The infant stimulates the erotogenic zone freed from need, creating a second erotogenic zone. This is accompanied by fantasy activity, which then replaces this self-production of pleasure. The ego thus develops and becomes autonomous through the internalization of maternal functions (1905d).

The maternal object is at the origin of desire, but is sensorially initially known with certainty by the pleasure ego. In the infant's first memories, perception of this object is associated with cessation of unpleasure, sensations of nursing or contact, and the pleasure of elimination. The infant is vitally dependent on this perception, since it compensates for its original powerlessness. The numerous memory traces left behind serve various functions. The ego makes use of memories of the shared origin of pleasure and memories of the maternal object to maintain the two modes of mental operation. Internally, the ego begins to conceive of the continuity of the internal object through hallucinated reinvestment of the memory traces. Between inside and outside, ego responses, combined with the emotive and muscular expressions of tension, gives meaning: It establishes mutual understanding and provides a basis for gratitude. Externally, the maternal object, although essential, is lost, sought for (1926d [1925]), and possibly rediscovered. The mother's absence and the loss of the object (initially unthinkable other than as a malefic occurrence) are prototypes of danger. The desire for the mother unaccompanied by her presence triggers anxiety and mobilizes thought.

“For the infant the psychic maternal object replaces the fetal biological situation” (1926d [1925]). The breast epitomizes that sensory object, which has become mental. A part of the ego-other, susceptible of being lost outside yet preserved inside, the sensory object thus forms the core around which narcissistic unity is organized. The infant's consciousness of no longer being the

breast triggers a constructive depressive crisis during weaning in subjects introduced to the oedipal drama. The maternal fusion is then repressed to promote a bond with the mother. Yet unconscious ideals continue the infant's primary identification with the original infant-mother unity.

Whenever an aspect of the repressed primary maternal fusion becomes conscious, a feeling of the uncanny overcomes the subject, while regression promotes the subject's nightly hallucinatory return to the maternal breast in dream thoughts (Braunschweig and Fain, 1975). The child—seduced by the care he has incorporated with repressed sexual aspects of the mother, and subject to continued excitation of this internal sensory object whose signifiers are enigmatic—attempts to control the experience by repeating it autoerotically.

The subject's imago, an imaginary schema, arises from the libido-charged imprint resulting from the attentions of the mother and attached to the subject's inner core. It provides a focus for regression, orients the choice of a man's sexual object later in life, and definitively marks the secondary nature of the relationship of a daughter to her father and to men. For the mother, a girl who has become a woman, maternal love prolongs sublimated sexuality as an alloy of narcissism and object love. Unbounded solicitous affection gives rise to a "shared illusion" of unity between mother and child: the child constructs itself in unity with the maternal, in a space for a two, seeking reciprocity, which is then individualized.

The mother then leaves the phase of "primary maternal preoccupation" to address her womanly desire for a lover and her sexuality. This introduces the child to its limitations (Aulagnier, 1975/2001). Maternal affection is a reaction formation, a compromise between sexual and aggressive drives.

Melanie Klein presents the bisexual maternal as the foundation of the psychic world, which contains both good and bad objects. For Donald Winnicott, only satisfaction of initial psychic and somatic needs frees the subject from the illusion of omnipotence and establishes the pleasure of thinking. For Wilfred Bion, maternal reverie initiates thought. And for Didier Anzieu (1989), perceived maternal affects form part of the skin-ego. Freud thus initiated a series of developments in thinking on mother-child attachment and interaction that has continued to this day.

ANNE AUBERT-GODARD

*See also:* Abandonment; Absence; Ajase complex; Alpha function; Anaclysis/anaclytic; Archaic mother; Breastfeeding; Censoring the lover in her; *Collected Papers on Schizophrenia and Related Subjects*; Counter-Oedipus; Dead mother complex; Double bind; Early interactions; Erotogenicity; Eroticism, oral; False self; Family; Family romance; Feminine sexuality; Femininity; Fort-Da; Good-enough mother; Handling; Holding; Homosexuality; I; Identification; Identifactory project; Illusion; Imaginary identification/symbolic identification; Infans; Infant development; Infant observation (therapeutic); Intergenerational; Lost object; Love; Maternal care; Maternal reverie, capacity for; Mother goddess; Narcissism; Negative therapeutic reaction; Object; Object, change of/choice of; Object relations theory; Oceanic feeling; Oedipus complex; Parenthood; Perversion; Phallic; Phallic mother; Phallic woman; Postnatal depression; Pregnancy, fantasy of; Primary love; Primary need; Primary object; Real, Symbolic, and Imaginary father; Reverie; Signal anxiety; Social feeling (individual psychology); Sucking/thumbsucking; Symbiosis/symbiotic relation; Technique with adults, psychoanalytic; Want of being/lack of being; Weaning; Wish for a baby; Wish, hallucinatory satisfaction of a.

### **Bibliography**

- Anzieu, Didier. (1989). *The skin ego* (Chris Turner, Trans.). New Haven, CT: Yale University Press. (Original work published 1985)
- Aulagnier, Piera. (2001). *The violence of interpretation: From pictogram to statement*. East Sussex/Philadelphia: Brunner-Routledge. (Original work published 1975)
- Braunschweig, Denise, and Fain, Michel. (1975). *La nuit, le jour: Essai psychanalytique sur le fonctionnement mental*. Paris: Presses Universitaires de France.
- Freud, Sigmund. (1905d). Three essays on the theory of sexuality. *SE*, 7: 123–243.
- . (1926d [1925]). Inhibitions, symptoms, and anxiety. *SE*, 20: 75–172.
- . (1950c [1895]). Project for a scientific psychology. *SE*, 1: 281–387.

---

## **MATERNAL CARE**

Maternal care covers all aspects of the mother's care-taking activity from her child's birth until it reaches the age of twelve to fifteen months, or, in the view of some authors, such as John Bowlby, the age of three years. Primarily, it is the quality of the relationship established by the mother with her infant and main-

tained throughout this period. While “the mother” usually means the woman who has carried the child to term and looks after it after birth, in the present context it may also denote any person who fulfills the maternal role in a continuous fashion from birth on (mother substitute).

The concept of maternal care is essentially post-Freudian. Freud assigned the mother no primary structuring role in the mental development of the child, nor did he view the loss of the mother as a traumatic event of particular import when it occurred in the child’s earliest years. He did, however, make mention of maternal care in a footnote on the “autistic” fiction of a shell in his paper on the “Two Principles of Mental Functioning” (1911b, pp. 219–220n). And towards the end of his life, he intuited the importance of the mother-infant relationship, describing it as “unique,” and as “the prototype of all later love-relations” (1940a [1938], p. 188), and suggesting the existence of an early sexualized relationship centered in particular on the oral satisfactions the infant obtains from feeding.

The idea of maternal care was developed during the 1950s, starting from two different, if overlapping, areas. The first was a concern with the fact that the mother’s extended absence—the effective loss of the mother—could lead to a depressive response on the part of the child (Spitz, 1946), to anxiety reactions, or to developmental delays. The term was used in the same sense but in a somewhat more official way in John Bowlby’s report to the World Health Organization (1951), which provided a critical review of clinical studies and research on the harmful results of deficiencies in maternal care. Bowlby’s monograph precipitated major changes in the practices of institutions and childcare centers in many countries.

In the second place, the pediatrician and psychoanalyst Donald Winnicott contributed much to the establishment of the idea of maternal care by describing a particular state that he called “primary maternal preoccupation” (1956/1958): a hyperacute state that allowed the mother to respond with sensitivity and delicacy to the very first demands of her infant. Winnicott also placed great stress on the need to recognize and describe what he called the “good-enough mother,” who by virtue of her constant presence was able to meet the child’s basic needs, present the world to it in acceptable doses, and protect it from stimuli, whether of internal or of external provenance, that

were too intense. And lastly he underscored the reciprocal nature of mother-infant interaction.

Before long, since a “lack” or “deprivation” of maternal care came to connote a great variety of situations, it was necessary to distinguish between inadequate of interaction with the mother (and the specific shortcomings of such interaction), and discontinuities within the mother-child relationship caused by frequent or permanent separations (Ainsworth, 1962).

This early work addressed both the failures of maternal care and the importance of high-quality mother-infant interaction. Subsequent research increasingly focused on the systematic observation of day-to-day relations between mother and infant. The outcome was a characterization of various well-defined phases. Thus the first three months of life were said to see the development of a synchronicity between mother and child founded upon waking and sleeping patterns, while the period between three and six months of age witnessed the emergence of reciprocal exchanges pleasurable to both parties, and the six-to-nine-month stage was marked by much more initiative by the child in its interaction with the mother (Sander, 1964).

Following the path opened up by Bowlby’s theory of attachment (1969), numerous studies were made of various behaviors indicating the child’s attachment to the maternal figure: smiling, vocalization, tears at moments of separation, the tendency to follow the mother no matter how little she moved, and so on. Little by little, the notion of maternal care was defined more precisely in terms of the availability of the mother figure, her accessibility to the expressed needs of the child, and her degree of sensitivity to, and comprehension of, those needs (Ainsworth et al, 1978). Daniel Stern (1985) has employed the word *attunement* to describe the bond made between mother and child in the first months. Regularity, continuity, and consistency seem to be the qualities essential to the satisfactory unfolding of mother—infant interaction.

It has become clear that a close correlation exists between the quality of the maternal care received in the first year of life and the quality of the attachment manifested by the child on reaching the age of one. A young child is “secure” when the mother has managed to be sensitive to its needs and respond to them in an adequate and consistent manner, “insecure-resistant” when the mother has generally responded erratically to its needs and signals, and “insecure-avoiding” when



its care has been mediocre or where it has been simply rejected. (Ainsworth et al., 1978).

Several studies have observed that, as the child becomes more sociable, mother and infant react a great deal to each other's affective states. Because mother-child interaction seems so emotional, studies emphasize the major role played by positive and negative affects in the child's overall development.

Research since the 1990s (Fonagy et al., 1993) seems to show quite clearly that the quality of maternal care throughout the first year of life is largely determined by the quality of the mother's attachment to her own mother.

YVON GAUTHIER

See also: Maternal.

### Bibliography

- Ainsworth, Mary D. Salter. (1962). The effects of maternal deprivation: A review of findings and controversy in the context of research strategy. In Mary D. Ainsworth and R. G. Andry, *Deprivation of maternal care*. Geneva: World Health Organization.
- Ainsworth, Mary D. Salter, Blehar, M. C., Waters, E., and Wall, S. (1978). *Patterns of attachment: A psychological study of the strange situation*. Hillsdale, NJ: Lawrence Erlbaum.
- Bowlby, John. (1951). *Maternal care and mental health*. Geneva: World Health Organization.
- . (1969). *Attachment and loss, Vol. I: Attachment*. New York: Basic Books.
- Fonagy, Peter, Steele, Miriam, Moran, George S., et al. (1993). Measuring the ghost in the nursery: An empirical study of the relation between parents' mental representations of childhood experiences and their infants' security of attachment. *Journal of the American Psychoanalytic Association* 41, 957–989.
- Freud, Sigmund. (1911b). Formulations on the two principles of mental functioning. *SE*, 12: 213–226.
- . (1940a [1938]). An outline of psycho-analysis. *SE*, 23: 139–207.
- Sander, Louis W. (1964). Adaptive relationships in early mother-child interaction. *Journal of the American Academy of Child Psychiatry*, 3, 231–64.
- Spitz, René A. (1946). Anaclitic depression. *Psychoanalytic Study of the Child*, 2, 313–42.
- Stern, Daniel N. (1985). *The interpersonal world of the infant: A view from psychoanalysis and developmental psychology*. New York: Basic Books.

Winnicott, Donald W. (1958). Primary maternal preoccupation. In *Collected papers: Through paediatrics to psychoanalysis* (pp. 300–305). London: Tavistock. (Original work published 1956)

### Further Reading

- Akhtar, Salman, Kramer, Selma, and Parens, Henri. (1996). *The internal mother. Conceptual and technical aspects of object constancy*. Northvale, NJ: Aronson, Inc.
- Furman, Erna. (1996). On motherhood. *Journal of the American Psychoanalytic Association*, 44(S), 429–448.
- Stern, Daniel. (1995). *The motherhood constellation: A unified view of parent-infant psychotherapy*. New York: Basic Books.

---

## MATERNAL REVERIE, CAPACITY FOR

Wilfred R. Bion developed the concept of the capacity for maternal reverie in his three books written during the 1960s: *Learning from Experience* (1962), *Elements of Psycho-Analysis* (1963), and *Transformations: Change from Learning to Growth* (1965).

Although he was an adult analyst and was primarily interested in group dynamics and the workings of psychosis, the concepts that he proposed (based on study of the analytic relationship in these two areas) in fact also proved to be very dynamic and very productive in connection with study of the foundations of the psychic apparatus—that is, the ontogenesis of the psyche.

In Bion's view, this ontogenesis of the psyche can be related to a digestive model of the workings of the "thought-thinking apparatus." At the beginning of its life, the baby does not have access to a thought-thinking apparatus that is mature enough to metabolize—that is, to use and integrate its very first mental or proto-mental materials. Bion thus described the beta (b) elements, which correspond to extremely archaic bodily feelings, to emotional states linked to the infant's very earliest sensory and relational experiences, which it cannot utilize as such. There is thus a need, for the baby—that is, for its mental growth and maturation—for a detour through the Other.

The infant projects these beta elements into the psyche of its mother (or other adult caregiver); this adult effectively lends the child their own "thought-thinking apparatus" to reshape, detoxify, and transform the beta elements into alpha (a) elements, which can then be assimilated by the infant and integrated into its

own mental functioning. This transformation is due to the “alpha function” of the mother’s psyche, or “capacity for maternal reverie,” which thus fulfills what could be described as a “desaturating” function with regard to the beta elements produced and felt by the infant (or by the patient).

From vantage point of the history of ideas, the emergence of this concept is situated at the confluence of Bion’s ideas on the functioning of groups, which also have a containing and transformative function (containers), and his analytic practice with adult psychotics: “If the patient cannot transform his emotional experience into alpha elements, he cannot dream,” he wrote in *Elements of Psycho-Analysis*.

This model is indissociable from the grid that Bion proposed to categorize the different types of mental materials (horizontal rows) and the various ways these can be used in communication (vertical columns). The beta and alpha elements correspond to the first two horizontal rows (A and B) of the grid, the last row of which is the “algebraic calculus” (H).

The extrapolation of this model to early psychic development was effected more by later theorists of child analysis than by Bion himself. In France, René Diatkine published *L’Enfant dans l’adulte ou l’éternelle capacité de rêverie* (1994; The child in the adult; or, the eternal capacity for reverie), in an implicit homage to all that this concept has contributed to the work of child analysts. In Diatkine’s view, the concept of the maternal reverie must be understood along with Jean Laplanche’s work on psychic translation in the context of his theory of generalized seduction.

BERNARD GOLSE

*See also:* Hallucination; Infant development; Infantile psychosis; Primary object; Protective shield; Psychotic panic; Negative capacity; Non-verbal communication; Thought-thinking apparatus.

### Bibliography

- Bion, Wilfred R. (1962). *Learning from Experience*. London: Heinemann; New York: Basic Books.
- . (1963). *Elements of Psycho-Analysis*. London: Heinemann.
- . (1965). *Transformations: Change from learning to growth*. London: Heinemann.
- Diatkine, René. (1994). *L’Enfant dans l’adulte ou l’Éternelle Capacité de rêverie*. Neuchâtel and Paris: Delachaux & Niestlé.

Laplanche, Jean. (2001). From the restricted to the generalized theory of seduction. In J. Corveleyn, and P. Van Haute, (Eds.), *Seduction, suggestion, psychoanalysis* (pp. 9–24). Belgium: Presses Universitaires de Louvain. (Original work published 1999)

## MATHÈME

In Greek, *mathêma* means “that which is taught.” Following the same path that led Freud to the discovery of slips and jokes, Lacan forged connections between the fields of spoken discourse and logical inscription. In 1955, he introduced what could be called his first matheme, schema L.

The main Lacanian mathemes in order of their appearance are:

1. *Schema L* (1955), which identifies four points in the signifying chain: first, the unconscious, or the discourse of the Other (A), and then the subject (S), which in turn results from the relation between the ego (*a*) to the other (*a'*).
2. *The formula of the signifier* (1957), *S/s*, links the laws of the unconscious discovered by Freud to the laws of language (metaphor and metonymy).
3. *The “big graph”* (1957) represented two different stages of the signifying chain. Lacan situated jouissance, castration, the signifier, and the voice at the various points of intersection on this graph.
4. *The four discourses* (1969) were used to link the discourses of the master, the university, the hysteric, and the analyst. Four terms—*S1*, the master signifier; *S2*, knowledge;  $\$$ , the subject; and *a*, surplus enjoyment—turn in a circular motion to take up four successive positions defined by the discourse of the master: the agent, the other, the production of the discourse, and truth.
5. *The formulas of sexualization* (1972) present sexual difference as a logical inscription. Using the signs  $\exists x$ ,  $\Phi x$ , and  $\forall x$  outside of the field of mathematics where they originated, Lacan inscribed a masculine psychical structure on one side and a feminine psychical structure on the other.

The Lacanian matheme is characterized by being both open and asymmetrical. It does not tend towards closing discourse, and in spite of its character as a statement, it is primarily an enunciation. And there lies the paradoxical aspect of the enterprise—to found a science of the subject. Even though Lacan finally

concluded (at the 1978 Congress of the *École freudienne de Paris*) that there can be no transmission of psychoanalysis, he always situated psychoanalysis within knowledge: access to the unconscious is legible and transmissible. Mathemes advance and illustrate the theses that in relation to speech and writing, another structure besides that of grammar or syntax organizes speech, namely the structure of the signifier.

The Lacanian *matheme* proceeds neither by faith nor by pure mathematics. Lacan situates religion on the side of making real, or “realizing,” the symbolic of the imaginary, or RSI (Seminar 21, session of November 13, 1973). On the other hand, Lacan defined mathematics as imagining the real of the symbolic, or IRS. If such were the case with the *matheme*, then it could become a model of the real. In fact, it is no such thing. Lacan never used mathematics as a demonstration, but as an exercise necessary for a better reading of the unconscious. Thus the *mathemes* should be read with a shift that allows for them to be situated as a symbolizing of the imaginary of the real, or SIR .

HENRI CESBRON LAVAU

*See also:* Four discourses; Graph of Desire; L and R schemas; Sexuation, formulas of; Signifier/signified.

### **Bibliography**

Darmon, Marc. (1990). *Essais sur la Topologie Lacanienne*. Paris: Éditions de l'A.F.I.

Lacan, Jacques. (2002). *Écrits: A selection* (Bruce Fink, Trans.). New York: W. W. Norton.

———. *Le Séminaire-Livre XXI, Les non-dupes errent* [Those Who Aren't Duped Err/The Names of the Father] (1973–1974). Unpublished seminar.

## **MATHILDE, CASE OF**

The Mathilde case involves a patient of Freud's whose death, from a medical overdose, is discussed in his commentary on the “dream of Irma's injection.” Mathilde S., a twenty-seven-year-old woman, came to see Freud at the beginning of 1889 for treatment. She presented the signs of inhibition, self-reproach, and delusional melancholia. The trigger turned out to be a broken promise of marriage that had been made to her. After a significant improvement with hypnotic treatment, the patient decompensated while Freud was away, with polymorphous symptoms, and had to be

hospitalized in October 1889 in a private psychiatric clinic in Vienna.

At the clinic it became obvious that the patient was developing erotomania, whose object was initially Freud, then a physician at the institution. The circumstances supported the diagnosis of a transference psychosis. It appears that the patient's eroticized transference reinforced the ideas that Freud's former teacher, the psychiatrist Theodor Meynert, was defending at the time, specifically with respect to hypnosis.

While the patient was hospitalized, use was made of the entire range of medications available at the time: morphine, chloral hydrate, valerian, bromide, digitalin, opium, scopolamine, and sulfonal, a sedative that had recently been discovered. Unwanted and extremely severe side-effects resulting from the chloral hydrate endangered the patient's life. But she recovered and left the clinic in May 1890, still suffering from melancholia.

Freud resumed treatment, prescribing alternating high doses of chloral hydrate and sulfonal, but apparently did not hypnotize her further. In the autumn she displayed a heightened pattern of vomiting, abdominal pains, and retention of urine, which was red in color. At the end of September the patient died. Shortly afterwards, a warning was issued against this kind of medication, and Mathilde's clinical symptoms were recognized as the expression of the presence of a severe hepatic porphyria resulting from the medication. In a report that was succinct and clear, Freud assumed responsibility for the fatal consequences of his treatment.

Five years later, as part of his associations with the dream of Irma's injection, Freud recalled this case, and his feelings of guilt were plainly apparent when he made the connection between his fear for the life of his daughter Mathilde, who was suffering from diphtheria—Behring had just introduced the serum therapy that was to save so many lives—and this case with its dramatic outcome: “This Mathilde for the other Mathilde, an eye for an eye, a tooth for a tooth.” In the dream and its interpretations, feelings of guilt reappear concerning the failure to take medical precautions, and the secondary effects of the medication and the hypnosis; but along with these there is also present the fantasy of becoming a kind of “Behring of neuroses.”

ALBRECHT HIRSCHMÜLLER

*See also:* Irma's injection, dream of.

### Bibliography

Freud, Sigmund. (1891e). Mitteilung über eine Sulfonalvergiftung [Wiedergabe aus zweiter Hand]. In Adolf F. Jolles, *Über das chemische Verhalten der Harne nach Sulfonal-Intoxikation—Internat. klin. Rdsch.*, Bd. 5 (1891), Sp. 1913–1916, 1953–1959.

———. (1900a). The interpretation of dreams. *SE*, 4–5.

Hirschmüller, Albrecht. (1989). Freuds “Mathilde,” Ein weiterer Tagesrest zum Irma-Traum. *Jahrbuch für Psychoanalyse*, 24, 128–159.

### MATTE-BLANCO, IGNACIO (1908–1995)

Chilean physician, Ignacio Matte-Blanco was born at Santiago de Chile on October 3, 1908, and died on January 11, 1995, in Rome. The scion of an old Chilean family, he was educated at the German Gymnasium at Santiago and graduated as physician-surgeon at the University of Chile in 1930.

Before leaving Chile for London, Matte-Blanco was in analysis with Fernando Allende Navarro, Latin America's first qualified psychoanalyst. He trained at the Maudsley Hospital and in psychoanalysis at the London Institute, where he supervised with Anna Freud and James Strachey, becoming a member of the British Society in 1938. Then he worked in New York with mathematician Courand, who encouraged his seminal paper on the relationship of set theory and psychoanalysis. Returning to Chile in 1943, he became the founder and guiding soul to the Chilean Society and a noted professor of psychiatry at the University of Chile from 1949 until his departure for Rome in 1966. He was a professor of psychiatry at the University of Chile Medical School, 1949–1966, and at Catholic University of the Sacred Heart, Rome, 1970–1974. He remained a teacher and a center of innovative discussion up to his death.

Matte-Blanco's pioneering paper, presented at the First Latin American Psychoanalytic Congress in Buenos Aires in 1956, “Expression in Symbolic Logic of the Characteristics of the System Ucs., or the Logic of the system Ucs.,” appeared in the *International Journal of Psycho-Analysis* in 1958. His two main books, *The Unconscious as Infinite Sets* (1975) and *Thinking, Feeling and Being* (1988), were published in London. Relevant papers published in Italian are not widely known.

In the idea that much of the wealth of our clinical practice is simply not seen because it does not fit with the theories we use, Matte-Blanco redresses in terms of modern logic Freud's fundamental distinction of primary and

secondary processes in *The Interpretation of Dreams* (1900a) and later, in “The Unconscious” (1915e). Absence of contradiction between the representations of diverse impulses and the ensuing absence of negation; displacement; condensation; atemporality; and substitution of external by psychic reality, that is, the qualities ruling in the unconscious, differ drastically from those secondary processes, this is, of Aristotelian, symbolic or scientific logic. Building upon von Domarus's “logic of the attribute” found in schizophrenic thought, Matte-Blanco holds that the characteristics of the unconscious derive from two principles: 1) The principle of Generalization: Unconscious logic does not take account individuals as such, it deals with them only as members of classes, and of classes of classes. 2) The principle of Symmetry: The Unconscious can treat the converse of any relation as identical to it; that is, it deals with relationships as symmetrical. The Freudian qualities of the unconscious result from the principle of Symmetry, or from both principles operating together. Thus, atemporality derives from symmetry, which precludes order in a temporal series, and displacement treats two individuals as members of the same class. Later on Matte-Blanco restates this saying, after Frege, that the unconscious operates in terms of propositional functions.

JORGE L. AHUMADA

*Work discussed: Unconscious as Infinite Sets, The. An Essay in Bi-logic.*

*See also:* Chile; Federación psicoanalítica de América latina; Italy.

### Bibliography

Etchegoyen, R. Horacio, and Ahumada, Jorge L. (1990). Bateson and Matte Blanco: Bio-logic and bi-logic. *International Review of Psycho-Analysis*, 17, 493–502.

Jordán-Moore, Juan-Francisco. (1995). Ignacio Matte-Blanco. *International Journal of Psycho-Analysis*, 76, 1035–1041.

Matte-Blanco, Ignacio. (1975). *The unconscious as infinite sets*. London: Duckworth.

———. (1988). *Thinking, feeling and being* (Eric Rayner and David Tuckett, Trans.). London: Routledge.

Rayner, Eric. (1996). *Unconscious logic*. London: Routledge.

### MATURATION

Maturation, in the broad sense, means all of the processes in the course of the development of an organism

that lead it to a mature state. In a more precise sense, it can be taken to mean the set of preprogrammed mechanisms that set in motion and coordinate the functions necessary for the life of the organism, before they come into operation, and for which biological maturation creates the means and conditions.

The term has made only marginal appearances in psychoanalytic literature. It would seem that Freud never used it in his writings, as evidenced by its absence in James Strachey's detailed index to the Standard Edition.

However, Donald W. Winnicott called one of his books *The Maturational Processes and the Facilitating Environment*, but, as the title itself indicates, the term is used with the broad understanding that most of the work on mental development could be considered to be studies of maturation. With explicit references to embryogenesis, René Spitz (1979) attempted to describe the *organizers* that preside over the succession of maturative stages of the mind (the first smile, walking, language)—these organizers themselves being preprogrammed.

From a totally different angle, the adjective *maturing* is sometimes used to characterize some of an analyst's interpretations in the course of the treatment, in a sense similar to what led James Strachey in 1969 to refer to *mutative* interventions. Here the term is used to designate interpretations that favor the process of maturation in the treatment through a reorganization of the psychic apparatus.

ROGER PERRON

*See also:* Adolescence; Archetype (analytical psychology); Genital love; Libidinal development; Imaginary identification/symbolic identification; Integration; Parenthood; Premature/prematurity; Puberty; Stage (or phase); Time; Transgression.

### **Bibliography**

Spitz, René. (1979). *L'embryologie du moi. Une théorie du champ pour la psychanalyse*. Paris: Complexe.

Strachey, James. (1969). The nature of the therapeutic action of psycho-analysis. *International Journal of Psycho-Analysis*, 50 (2), 275–291.

Winnicott, Donald W. (1965). *The maturational processes and the facilitating environment*. London: Hogarth and the Institute of Psycho-Analysis.

## **MAUCO, GEORGES (1899–1988)**

Georges Mauco, housemaster in the Seine school for elementary school teachers, educationist, demographer, and psychoanalyst, was born in Paris on April 16, 1899, and died there on May 18, 1988. The son of a waiter who later became a landowner, he was reared in the country by an agricultural laborer. He was mobilized in the *Armée de l'Orient* in 1918 and left the army in 1920 as *maréchal des logis* (the approximate equivalent of a sergeant). He graduated with a bachelor's degree in history and commenced analysis with René Laforgue.

His thesis, *Les étrangers en France: Leur rôle dans la vie économique* (Foreigners in France: Their role in economic life) was published in 1932. Although he argued in favor of integration, he claimed that Asians, Africans, and Levantines were unassimilable. In 1937 he wrote a paper recommending that the Israelites be sent to the countryside. This project was rejected even though it was proposed to the government while he was a member of the committee for the French population in Léon Blum's cabinet.

He was demobilized in 1940 and collaborated on the journal *Ethnie française* (The French ethnic group), run by Georges Montandon, a well-known anti-Semite. While under oath in the Supreme Court (during the Riom trial), he affirmed that foreign Jews in France were one of the major causes of defeat in 1940.

He escaped the purges after the war. With the support of General Charles de Gaulle, who appointed him secretary of the High Commission for the Population and the Family, he created the first psychoeducational consultancy in the Lycée Claude-Bernard in Paris. Many psychoanalysts worked there as consultants and analysts.

A believer in the right to be different, after 1946 he devoted considerable energy to defending children against adults, psychologists against doctors, the youth of 1968 against the bourgeoisie, and women's liberation. He defended Margaret Clark-Williams, a colleague of Claude-Bernard, when she was attacked by the Medical Association. In 1953, along with Didier Anzieu, he founded the Union of Psychoanalysts and Psychologists.

He recovered from leukemia in 1956 after a stay at high altitudes. He wrote an article in *L'Express* recounting this experience and denouncing the high

priests of medical knowledge. His last book, published in 1977, was devoted to the question of foreigners. It studied racism and the unconscious responsibility of victims of racism.

JEAN-PIERRE BOURGERON

See also: Centre psychopédagogique Claude-Bernard; Clark-Williams, Margaret; France; Société française de psychanalyse.

### **Bibliography**

- Mauco, Georges. (1932). *Les étrangers en France: Leur rôle dans la vie économique*. Paris: Armand Colin.
- . (1975). *L'évolution de la psychopédagogie*. Toulouse, France: Pragma-Privat.
- . (1977). *Les étrangers en France et le problème du racisme*. Paris: La pensée universelle.
- . (1982). *Vécu 1899–1982*. Paris: Émile Paul.
- Roudinesco Élisabeth. (1995, Fall). Georges Mauco, 1899–1988, un psychanalyste au service de Vichy: De l'antisémitisme à la psychopédagogie. *L'infini*, 51, 73–84.

## **MEAD, MARGARET (1901–1978)**

Margaret Mead, an American anthropologist, was born on December 16, 1901, in Philadelphia and died on November 17, 1978, in New York City. She spent her entire career as a curator of the American Museum of Natural History and was an associate professor at Columbia University. After studying psychology and anthropology at Columbia, where she was influenced by the work of Franz Boas and Ruth Benedict, Mead first did fieldwork in eastern Samoa. In the published result, *Coming of Age in Samoa* (1928), she wrote, “[A]dolescence represented no period of crisis or stress, but was instead an orderly developing of a set of slowly maturing interests” (p. 109). She also noted, within “a larger family community, in which there are several adult men and women, seems to ensure the [Samoan] child against the development of the crippling attitudes which have been labelled Oedipus complexes [and] the Electra complexes” (p. 147).

She made several trips to New Guinea and reported her findings in *Growing Up in New Guinea* (1930) and *Sex and Temperament in Three Primitive Societies* (1935). Through these writings, Mead established herself as the leading proponent of the so-called “culture

and personality” school of anthropology. Her work emphasizes the diversity of cultures and the plasticity of human nature, the preponderant influence of cultural models in the development of personality, and the cultural determination of sexual roles (1949). Influenced by the work of Erik H. Erikson and Gregory Bateson (her third husband), Mead saw trauma specific to individual cultures as leading to particular types of development in those culture. Relying mostly on photographs, she attempted to describe the infantile experiences that determine the formation of character (Bateson and Mead, 1942).

Although she sometimes used psychoanalytic concepts (identification, erotogenic zone, narcissism), she was primarily engaged in a relativist critique of psychoanalysis. For example, she reproached Freud for confining himself to an examination of the “specific ambivalence of attitudes institutionalized in our own culture.” She believed she had refuted Lucien Lévy-Bruhl, Jean Piaget, and Freud by showing that primitive children “displayed no tendency for spontaneous animist thought.”

Mead’s work, unable to escape the doubts of relativism, has been contested both ethnographically and theoretically (Freeman, 1983). Her principal merit is that she drew anthropologists’ attention to the importance of early infancy, education, diet, and sexuality. Her criticisms of psychoanalysis, however, were based on considerable misunderstandings of the field, as she herself later recognized. “Instead of making the laborious and often painful effort of understanding psychoanalysis, we have been content to use some of its products, especially projection tests,” she wrote. As a result, Mead’s observations relate only to manifest behavior and not to intrapsychic conflicts or the unconscious.

BERTRAND PULMAN

See also: Oedipus complex; United States.

### **Bibliography**

- Bateson, Gregory, and Mead, Margaret. (1942). *Balinese character: A photographic analysis*. New York: New York Academy of Sciences.
- Freeman, Derek. (1983). *Margaret Mead and Samoa: The making and unmaking of an anthropological myth*. Cambridge, MA: Harvard University Press.
- Gordan, Joan (Ed.). (1976). *Margaret Mead: The complete bibliography, 1925–1975*. The Hague: Mouton.

- Mead, Margaret. (1928). *Coming of age in Samoa*. New York: William Morrow.
- . (1930). *Growing up in New Guinea*. New York: William Morrow.
- . (1935). *Sex and temperament in three primitive societies*. New York: William Morrow.
- . (1949). *Male and female*. New York: William Morrow.
- . (1972). *Blackberry winter: My earlier years*. New York: William Morrow.
- . (1978). The evocation of psychologically relevant responses in ethnological field work. In George D. Spindler (Ed.), *The making of psychological anthropology* (pp. 88–139). Berkeley: University of California Press.

## MEGALOMANIA

Megalomania is commonly understood as a mental behavior characterized by an excessive desire for power and glory and by illusory feelings of omnipotence. The latter can be expressed in the psychopathological form of delusions of grandeur.

Megalomania can be understood as exacerbated narcissism in relation to the ideal ego. In his account of the Schreber case in “Psycho-Analytic Notes on an Autobiographical Account of a Case of Paranoia (Dementia Paranoides)” (1911c [1910])—a case that presented its share of delusions of grandeur—Sigmund Freud envisaged narcissism as a stage in psychosexual development situated between autoeroticism and object relations. Narcissism can certainly be placed not just within a linear perspective, but also as a structural point in the psyche, with megalomania at its zenith. Indeed, if we postulate a primal intersection formed by the interaction between primary narcissism and primal masochism, conceptualized as the earliest fusion of the life and death instincts, we are led to envision a sort of primal, archaic damming-up that is self-constituted (and therefore without an object) in the psyche. Megalomania could then be considered as an expression of reactualization and regression to this primal position, which is characterized by an image of an ego ideal that is all-powerful and self-sufficient, having no object-directed needs or desires in order to survive. This type of mental functioning would also involve a systematic denial of otherness and an infantile theory of sexuality involving self-procreation.

These structural elements, present in every psyche, and especially in every formation of the ego, are expressed in the various modes of psychic representation—pictographic, fantasmatic, and ideational. Omnipotence and denial of the other’s reality are the organizing framework.

The “ideal ego” is posited as being the intrapsychic formation that engenders megalomania. Different from the “ego ideal,” it is the psychic agency that inherits infantile primary narcissism; it maintains the possibility of recourse to an ideal of omnipotence and, by that very fact, to an attitude that negates the existence of the object and otherness. As the guardian of imaginary omnipotence, in the realm of identifications the megalomaniacal ideal ego opposes taking into account the separating and symbol-generating elements of gender and generational differences. It is the organizer of defense mechanisms such as the denial of reality, and accordingly, the disavowal of castration.

To be sure, in paranoid and melancholic types of psychopathological organizations one can find the effects of the megalomaniac’s colorful frames of reference. In paranoia, persecution is the mechanism that continually justifies the omnipotence of the ego, which is attacked only to better demonstrate the megalomania’s validity. Finally, the ultimate persecutor is only a jealous god on the verge of being supplanted by the new god that is the ego. In melancholia, megalomania is also linked to the process of narcissistic identification with the object. This confusion of identities makes mourning and separation impossible. Megalomania as an extreme form of manic defense can be one outcome of the process of melancholia. If we recall that another possible outcome is suicide, megalomania can be considered an attempt to deny death and a defense against the anxiety resulting from separation from the object.

In addition to its pathological forms, megalomania is a mental behavior that can be used by any individual as a way of coping with distress linked to frustration, abandonment, loss, or disappearance of the object. The megalomaniacal fantasy is then a desperate attempt to repair an ego that has been damaged by object-loss experienced as an amputation or mutilation, which are the prototypes of castration. Getting beyond this psychic position marked by omnipotence requires the presence of another person in the role of “word-bearer” (Aulagnier, 1975/2001), someone who can endow object-loss and the attendant feelings of

anxiety with a representation and a meaning. Thus there is a need for the exercise of a word-bearing function, generally allotted to the mother, which will be re-created in the context of analysis.

The calling into question of infantile megalomania involves the psychic work of de-idealizing the omnipotent ideal ego of the *infans* period and a reorganization of the psyche to take into account the desire of the other in his or her difference. This redefinition of the ideal requires appropriation of an ego ideal that is external to the subject and which preexists him or her in the symbolic realm that governs exchanges in accordance with the taboos against incest and murder. As a form of disavowal, megalomania is thus a tendency to remain unconsciously within a realm of barbarous images in which desires for murder and incest can be satisfied and prohibitions against them transgressed. Megalomania reflects a transgression of the fundamental taboos as a way of avoiding sublimation, which is a socialization of the instinctual.

MARC BONNET

*See also:* Borderline states; Infans; Narcissism; Narcissistic elation; Paranoia; Rationalization; Wish, hallucinatory satisfaction of a.

### **Bibliography**

Aulagnier, Piera. (2001). *The violence of interpretation: From pictogram to statement*. East Sussex/Philadelphia: Brunner-Routledge. (Original work published 1975)

Freud, Sigmund. (1911c [1910]). Psycho-analytic notes on an autobiographical account of a case of paranoia (dementia paranoides). *SE*, 12: 1–82.

———. (1914c). On narcissism: An introduction. *SE*, 14: 67–102.

———. (1916–1917g [1915]). Mourning and melancholia. *SE*, 14: 237–258.

———. (1923). The ego and the id. *SE*, 19: 1–66.

## **MELANCHOLIA**

In the traditional language of psychiatry, *melancholia* denotes a type of depressive state characterized by its intensity and its responsiveness to biological antidepressant agents. The experience of the melancholic individual, often called “mental suffering,” is characterized by profound sadness and lack of interest in the

outside world. Melancholia brings about a form of pessimism that sees the future as blocked and unchangeable. Such pessimism is accompanied by ideas of guilt and unworthiness, which find expression through self-accusation and can even give rise to delusion. Hypochondriacal ideas are also frequent. In addition, the subject complains of emotional numbness and the painful sentiment of being unable to love. Mental suffering engenders a continual desire for death. Hence, the subject runs the risk of suicide. Melancholia is accompanied by a marked slowdown in psychomotor activity, sometimes leading to stupor. Classic signs of the illness are anorexia and weight loss, insomnia and disturbed sleep patterns, and an improvement in clinical symptoms in the evening.

An episode of melancholic depression can be unique or recurrent, in which case it becomes part of the framework of a manic-depressive illness that is unipolar (recurring melancholic episodes) or bipolar (recurring melancholic and manic episodes). The bipolar situation reveals a fundamental characteristic of melancholia: it can reverse itself spontaneously or under the effect of drug treatments, into a state of manic excitation.

Karl Abraham (1927b) noted the relationship between mourning and depression, and he distinguished melancholia from neurotic depression, which results from the failure to satisfy drives because of repressed unconscious factors. For Abraham, the structure of melancholia is closer to that of obsessive neurosis on account of the intense hostility toward the outside world. In both illnesses, hostility considerably reduces the ability to love, and this reduction is responsible for the onset of the illness. But in melancholia, the projection of hostile drives is combined with their repression. Abraham proposed a psychopathological model of psychotic depression, based on the Freudian model of paranoia, in which libidinal hatred, projected onto the outside world, reverts back onto the subject in the form of depressed feelings of being detested and of guilt (the source of masochistic pleasure).

In “Mourning and Melancholia” (1916–1917g [1915]), Freud based his thinking on how melancholia and mourning converge. They are both triggered by the same phenomenon, namely loss. They differ in that although mourning occurs after the death of a loved one, in melancholia the lost object is an object of love and therefore is not truly dead. Melancholic



individuals may, in some cases, know that they have lost something, but they never know what they have lost, for the loss is inaccessible to consciousness. The clinical signs of melancholia and mourning are identical, except that melancholia is accompanied by a loss of self-esteem. Unlike people in mourning, melancholic individuals suffer from a loss involving the ego, which they describe as poor and without value. They reproach themselves but do not experience shame, for their reproaches are really directed not at themselves but at lost objects. Their egos are split: one part, the critical faculty, takes as its object another part, which is identified as the lost object by means of a narcissistic mechanism. This process implies that the object choice is narcissistic and characterized by a strong fixation on the object but a weak cathexis of it, with cathectic energy always readily withdrawn into the ego.

For melancholia to occur, the object relationship must be ambivalent: hate and love must be in contention. Once love for the object has taken refuge in narcissistic identification, hatred can function against the part of the ego identified with that object. There it obtains sadistic satisfaction, as reflected in the melancholic individual's suicidal desires. Such desires result in hatred of the object being redirected back upon the self. The ambivalence, constitutional or associated with the circumstance of loss, leads to love and hate doing battle against one another in various parts of the unconscious psyche until love escapes into the ego to preserve itself and melancholia finds expression in the typical form we are familiar with. This confrontation always ends in exhaustion, whether the unrelenting struggle with the lost object stops on its own or the object is abandoned because it is without value.

In "Melancholia and Obsessional Neurosis" (1927a) Abraham investigated the relation between manic-depressive states and the pregenital stages of libidinal organization. After clarifying the connection between sadism and anal eroticism, he divided the anal-sadistic phase into two periods. In the earliest period, the drives obtain satisfaction by rejecting and destroying the object. During this first period the libido of the melancholic individual begins to regress. The libidinal regression does not end with the first period, however, but continues through the oral-cannibalistic stage by introjecting the lost object. This is accompanied by a refusal to eat, a key indicator of melancholic depression. Abraham concluded by listing five factors whose "interaction causes the specific clinical manifestations

of melancholia." These are the constitutional reinforcement of oral eroticism in melancholics, the fixation of the libido on the oral phase of its development, the injury to infantile narcissism caused by disappointment in love from the maternal object, the overcoming of this injury prior to the control of oedipal desires, and the repetition of this primary disappointment later in the life of the subject.

ALBAN JEANNEAU

*See also:* depression.

### **Bibliography**

Abraham, Karl. (1927a). Melancholia and obsessional neurosis. In *Selected papers of Karl Abraham, M.D.* (Douglas Bryan and Alix Strachey, Trans.; pp. 422–432). London: Hogarth. (Original work published 1924)

Abraham, Karl. (1927b). Notes on the psychoanalytical investigation and treatment of manic-depressive insanity and allied conditions. In *Selected papers of Karl Abraham, M.D.* (Douglas Bryan and Alix Strachey, Trans.; pp. 137–56). London: Hogarth. (Original work published 1911)

Freud, Sigmund. (1916–1917g [1915]). Mourning and melancholia. *SE*, 14: 237–258.

### **Further Reading**

Lupi, Robert, rep. (1998). Panel: Classics revisited: Freud's "Mourning and melancholia." *Journal of the American Psychoanalytic Association*, 46, 867–884.

Lussier, M. (2000). "Mourning and melancholia": The genesis of a text and of a concept. *International Journal of Psychoanalysis*, 81, 667–686.

---

## **MELANCHOLIC DEPRESSION**

Melancholic depression is a severe mood disorder that is psychotic in nature. In psychoanalysis, it is understood to arise from incorporation of the lost object (experienced as a bad, "abandoning" part-object) into the ego, which identifies with it. This object is then attacked by another part of the ego, the superego. The ego is thus the recipient of the reproaches (self-reproaches) and attacks targeting the object with which it has identified ("[T]he shadow of the object fell upon the ego," as Freud wrote in "Mourning and Melancholia" [p. 249]).

The above definition follows Freud's account almost to the letter. Freud used the term *melancholia*

to refer to depressive states in general. However, while this dynamic as described helps explain the various depressive states, it more precisely describes melancholic depression of the psychotic type. As early as 1911, Karl Abraham discussed the problems of depressive patients and thereafter continued to develop the characteristics of such personalities. He also gave a detailed account of the melancholic introjection of the lost object at once into the ego and into the superego. Sándor Rádo (1928) underscored the melancholia's purgative effects—the “processes of expiation and reparation” set in motion by the internal struggle between the superego and the ego. In Abraham's view, this struggle made possible the destruction and anal expulsion of the bad object. In this way the ego once more became worthy of entering into contact with good or idealized objects; and, ultimately, the route to mania was opened to it.

From the Kleinian perspective, Hanna Segal (1964) describes melancholia as the result of manic-schizoid defense mobilized against the depressive position. The melancholic's identification with the lost object tends to be of the projective kind—an archaic psychotic defense mechanism. This explains the almost perfect match between the ego and the part-object with which it becomes confused.

The defensive functioning is thus diametrically opposed to that of schizoid-paranoid mechanisms, where the ego identifies—most often projectively—with a more or less idealized object (Palacio Espasa, 1977). Indeed, as a counterpart to the variety of manic defenses seen across the whole range of mental operations, psychoanalytic experience shows different types of melancholic defenses designed to counter depressive anxiety; there are also paranoid defenses, or, on the contrary, neurotic anxiety. When the melancholic defenses are used against persecution anxiety, the persecuting-destructive aspects of the object with which the ego identifies are more visible, whereas in the face of depressive anxiety, the object's damaged/destroyed aspects come to the fore. The various psychic tendencies often called “masochistic” (based on expiation, appeasement, submission, propitiation through seduction, and so on) may be viewed as the range of essentially neurotic melancholic defenses.

FRANCISCO PALACIO ESPASA

See also: Depression.

### Bibliography

- Abraham, Karl. (1927). Notes on the psycho-analytical investigation and treatment of manic-depressive insanity and allied conditions. In *Selected Papers of Karl Abraham, M.D.* (pp. 137–156). London: Hogarth and the Institute of Psycho-analysis. (Original work published 1911)
- Freud, Sigmund. (1916–1917g [1915]). Mourning and melancholia. *SE*, 14: 237–258.
- Palacio Espasa, Francisco. (1977). Défenses mélancoliques versus défenses maniaques. *Revue française de psychanalyse*, 41 (1–2), 217–226.
- Rádo, Sándor. (1928). The problem of melancholia. *International Journal of Psycho-Analysis*, 9, 420–438.
- Segal, Hanna. (1964). *Introduction to the work of Melanie Klein*. London: Heinemann.

---

## MEMOIRS OF THE FUTURE

The concept of “memoirs of the future” or “inherent preconceptions” reveals Wilfred Bion's indebtedness to the ideas of Plato and Kant. The very wording of the concept was so appealing to Bion that he employed it as the overarching title for his psychoanalytic autobiography.

The paradox in the wording of the concept, “memoirs of the future,” designates the platonic idea of Ideal Forms, preconceptions which inherently accompany us from birth—and long before! They are older than the thinkers that think them and can anticipate their rendezvous with their future, external counterparts. Thus, the infant, “hard-wired” with the pre-conception of the idea of the breast, can anticipate and then locate that breast, when found, and thereby confer “conception” upon it as the reward for its success in finding what its pre-conception had already anticipated.

“Memoirs of the future” poetically implies that we are born with an atavistic “memory” of the history of the species, to which the specific pre-conception is a subset. Perhaps a concrete example would help. The human infant is born with a number of immune bodies in its immunological armamentarium which have already been “programmed” to anticipate future antibodies who are, as in the phenomenon of déjà vu, “strangely familiar.”

In his triadic autobiography (*A Memoir of the Future*, 1975, 1977, 1979), Bion proffered a highly original aspect of dialogics in the spirit of Bakhtin. He wrote, for instance, of different, split-off, personified

aspects of fetal mental life which appeared to be independent of one another and yet could communicate as if they were separate selves from different time zones of maturation—speaking to another, one from the future and other from the past.

JAMES S. GROTSTEIN

*See also:* Autobiography; Bion, Wilfred Ruprecht.

### **Bibliography**

Bion, Wilfred (1975). *A Memoir of the Future*. (Vol. I, *The Dream*). Rio de Janeiro: Imago (Reprinted, 1991. London: Karnak).

———. (1977). *A Memoir of the Future*. (Vol. II, *The Past Presented*). Rio de Janeiro: Imago (Reprinted, 1991. London: Karnak).

———. (1979). *A Memoir of the Future*. (Vol. III, *The Dawn of Oblivion*). Perth: Clunie (Reprinted, 1991. London: Karnak).

---

## **MEMORIES**

For psychoanalysis, memories are conscious representations of the past suspected of being, at least in part, illusory. The fact is that conscious memories or recollections may conceal unconscious ones, even if the ego accepts them at face value and finds comfort therein. In his early work Freud spoke of “unconscious memories,” but he later replaced this term with “memory traces.

In Freud’s initial work on the theory of neuroses (1894–96), “memories were pathogenic reminiscences of traumatic seduction; subsequently the memories of childhood were included in the category.

Freud contrasted the obsessive “memory image,” or “mnemonic image,” with the supposedly genuine memory adequate to the affect experienced. Memories could be false, however, from their inception (*Erinnerungsfälschung*): one has only to think of the “first lie” of the hysterical proton-pseudos of Freud’s “Project for a Scientific Psychology” (1950c [1895]), or of “screen memories” (1899a), behind which authentic memories lie.

Freud’s notion of memories, even when he uses it in the context of the psychology of consciousness in normal states, is always related to his first theory of the neuroses caused by traumatic seduction. It is not by

accident that Freud used two very similar words to designate two conceptually opposed concepts—conscious memory (*Erinnerung*) and the unconscious memory-trace (*Erinerungsspur*)—and the paradoxical expression “unconscious memory” can often be found in his writings. In the theory of the traumatic origins of hysteria, he constructs the notion of memory traces from that of unconscious memories: the conscious memory of the trauma has been refused, rejected, repressed, or split. It is no longer accessible to consciousness, at least not directly, and is now represented in altered form in the symptom, notably in the mnemonic symbol. The unconscious memory strives to become conscious once more, for ontically it is conscious. The notion of unconscious memories prefigures that of the unconscious, as distinct from the idea of a provisional pathological repression, which is still tainted by the psychology of consciousness; likewise, unconscious memory traces or mnemonic images are so intense and sensorially alive that they overflow into consciousness in a quasi-hallucinatory form nonetheless distinct from hallucination.

Memories are par excellence the memories of affects, “the persistent effect of an emotion experienced in the past” (1896a) in the “memory chain.” In Freud’s work there is much that belongs to the associative theory of memory. Memories, like the mnemonic symbols, screen memories, and fantasies, form “memory chains.” It was from this conception of memory that Freud developed the technique of free association, whence in turn he derived the notion of primary processes.

The archaeological metaphor accompanied the notion of memory throughout Freud’s work, from 1896 (“The Aetiology of Hysteria”), where he writes of the explorer, whose “interest is aroused by an expanse of ruins” and who “may start upon the ruins, clear away the rubbish, and, beginning from the visible remains, uncover what is buried.... If his work is crowned with success ... [it may] yield undreamd-of information about the events of the remote past, to commemorate which the monuments were built” (p. 192), to *Civilization and its Discontents* (1930a [1929]), where he introduces a visitor who discovers beneath the city of Rome not an ancient Roman city but the ruins of reconstruction performed at the end of the ancient era on the site of primitive buildings that have disappeared, attempting to picture to himself what might produce the simultaneity of

memories, here visual, of intertwined monuments from different eras.

What distinguishes between “true” and “false” memories is the affect, which is “always right” (1900a), and which can lead to the rediscovery, on the basis of the mnemonic symbol of the original idea. In the Emma case (1950c [1895]), the phobic symptom and the belief that an ordinary event from adolescence could be its cause concealed what should have been a memory but had become a memory trace, namely the scene of childhood seduction. The transition from conscious memory to unconscious memory trace follows the topography of a psychic internalization of the event requiring a certain amount of time. Every memory is more or less a screen, always suspected by Freud of not faithfully conveying the impressions of the actual experiences of childhood.

In *Leonardo da Vinci and a Memory of His Childhood* (1910c), Freud states that memories include both historically constituted memory-traces of perceptions in childhood and pure fantasy elements. In Leonardo’s memory a vulture opens the mouth of the child Leonardo with its tail, which Freud analyzes as the desire to have been engendered by a phallic mother. A memory then, appears to be a fantasy, but in fact the fantasy harbors real memories: the memory of having been passionately kissed by his mother during childhood, the memory of breastfeeding, the father’s absence—all essential elements described by Freud as “real nothings,” out of which Leonardo created his fantasy. Finally, what Leonardo remembers is not any specific event from childhood but elements from the psyche of the child he was, which constitutes the background of his adult psyche. Without realizing it Leonardo discovers on the lips of the Mona Lisa his mother’s smile, of which he has no memory.

In psychoanalysis the concept of memory is part of the paradigm of the lost object. In “Mourning and Melancholia” (1916–17g [1915]), Freud demonstrates how, in melancholia, the pathological memory fixes and fetishizes the idealized object, hated as much as loved, and how, in the work of mourning, all memories about the object are illuminated in their smallest detail, so that remembering may facilitate abreaction, followed by a withdrawal of cathexis.

Freud envisages a drive to remember (*Impuls zur Erinnerung*) whose motor is a wish for a kind of representation close to hallucination: where the “mnemonic

image,” the sensory intensity of the “unconscious memory” becomes conscious in a hypnoid mode by virtue of the lifting of amnesia. This drive also strives to rediscover the strength of the impressions (*Eindruck*) imparted by previous experience (*Erlebnis*).

In Freud’s original approach to therapy, centered on abreaction and remembering, memories were meant to confirm the accuracy of the interpretation. In “Remembering, Repeating and Working-Through” (1914g), Freud noted “the patient does not *remember* anything of what he has forgotten and repressed, but *acts* it out” (p. 150). “[T]he patient repeats instead of remembering” (p. 151). This leads to the possibility of a clinical approach based on working-through rather than remembering and abreaction, or, otherwise stated, a conception of remembering centered on constructions rather than memory. From this point of view a childhood memory is always a memory about childhood. The concept of memories belongs to the psychology of consciousness more than to the metapsychology of the unconscious, despite the obvious kinship between *Erinnerung* (memory) and *Erinnerungsspur* (unconscious mnemonic trace) in Freud’s work. An illusion of consciousness, memories support the defenses and idealizations of the ego.

No memory is exempt from the influence of fantasy, and no fantasy can do without ideational elements borrowed from a perceived reality. The notion of memory employed by Freud differed from that found in psychology and philosophy. Although in “Heredity and the Aetiology of the Neuroses” (1896a) he tried to establish the ages of memories because it was the oldest events that were the most pathogenic, he wrote to Fliess on May 2, 1897 that it was not, strictly speaking, memories that the hysteric repressed but instinctual impulses associated with stimulating fragments of memories. What he refers to as memories derive from multiple sources and are the object of constant reworking. In discussing the memories and the childhood dreams of the “Wolf Man,” Freud concluded that what was involved was a complex mixture of memories, fantasies, and day’s residues (1918b [1914]). Psychoanalytic interpretation rediscovers—but more often reconstructs—childhood memories with the help of screen memories, fantasies, and dreams, whose day’s residues, in combination with memory traces, give rise to visual representations that appear as memories. What is thus disinterred is the child’s psyche. The frequently debated question is whether analysis

constructs the mind as fiction or reconstructs the past facts to take into account the complexity and paradoxical nature of memories at once historical and subjectively constructed. The continuous rewriting of every subject's history by the subject himself defines memory as a temporary current version only. Freud played down the contrasts between memory and screen memory and memory and construction, emphasizing instead the complexity of psychic working-through, which mixes different types of mnemonic representations as well as non-mnemonic ones—including libidinal representations and unconscious and conscious thoughts. A memory is something other than a memory-trace, but there are points of contact between the two. Freud refuted the idealist psychology of consciousness but he also avoided falling prey to a metaphysics of an unconscious with no relationship to reality, perception, or memories.

FRANÇOIS RICHARD

*See also:* Acting-out/acting-in; Amnesia; Compromise formation; Cryptomnesia; Forgetting; “Heredity and the Aetiology of the Neuroses”; Isolation (defense mechanism); Neurotic defenses; Primal scene; Primary process, secondary process; Quota of affect; Remembering; Reminiscence; Repetition; Screen memory; Thing; Thought.

### **Bibliography**

- Freud, Sigmund. (1896a). Heredity and the aetiology of the neuroses. *SE*, 3: 141–156.
- . (1896c). The aetiology of hysteria. *SE*, 3: 186–221.
- . (1900a). The interpretation of dreams. *SE*, 4–5.
- . (1910c). Leonardo da Vinci and a memory of his childhood. *SE*, 11: 57–137.
- . (1914g). On narcissism: An introduction. *SE*, 14: 67–102.
- . (1950c [1895]). Project for a scientific psychology. *SE*, 1: 281–387.

## **MEMORY**

If one views memory as the ability to retain and recall past states of consciousness, then psychoanalysis has played a considerable role in its delineation. But in terms of memory theory considered more broadly, its significance is much more modest. Freud approached memory from three perspectives. In terms of

neurology, his contributions were original but limited. From the standpoint of psychology, he added to the pre-existing framework. Finally, in creating the psychoanalytic perspective, Freud essentially reworked views that had been extensively discussed in philosophy, literature, and scientific research.

In 1891 Freud's *On Aphasia: A Critical Study* (1891b) proposed a solution to the problem of memory retrieval and disorders of memory, which was much discussed at the end of the nineteenth century following the discoveries of Paul Broca. Freud did not take sides in the dispute between Broca, who localized language function to a specific cerebral area, and Carl Wernicke, who developed the functional concept of conduction aphasia. Freud's solution, which resembled the one that Henri Bergson adopted five years later in *Matter and Memory*, could serve as the basis for a dialogue between neurology and philosophy. But the 1891 text is a pre-psychoanalytic work.

Freud's second, psychological perspective finds him apparently subscribing to the theory of memory traces. Already expressed in its major outlines in Plato's *Theaetetus*, this theory was commonplace in the nineteenth century, when the vogue for scientific materialism made it seem self-evident (although spiritualists also accepted it). In this sense Freud is close to his contemporary, Théodule Ribot, but for Freud the theory of memory traces assumed a specific form intended to account for the role the unconscious plays in remembering. This led to Freud's *Project for a Scientific Psychology* of 1895 (1950c [1895]) and the best expression of the doctrine, in chapter 7 of *The Interpretation of Dreams* (1900a). The “Mystic Writing Pad” (1925a) represents an attempt to provide the theory of memory traces and process of memory retrieval with a metaphor suitable for psychoanalysis. But in these texts, Freud was concerned to place facts revealed by psychoanalysis within the framework of conventional psychological theory; he made no effort to create a new “theory of memory.”

Much more familiar (and often wrongly considered as the specific psychoanalytic contribution to problems of memory) is the third perspective, involving the alleviation of pathological symptoms by recalling forgotten traumata. Freud himself did a great deal to promote this point of view through the significance he attached in numerous of his writings to Josef Breuer's treatment of Anna O. Too common is the impression that the famous formula “hysterics suffer mainly from reminiscences”

(*Studies on Hysteria*, 1895d, p. 7) expresses the most fundamental idea in psychoanalysis.

There is no question that the idea of recollection constitutes an essential part of psychoanalytic therapy, and to think otherwise is to betray Freud in a fundamental way. Serge Viderman's claim in *La Construction de l'espace analytique* (1970) that the search for lost memories is one of Freud's youthful illusions to be replaced, in analysis, with co-constructions of subjectivity, is simply an attempt to employ non-analytic therapy, proposed in the past by such authors as Karen Horney. Until the end of his life Freud remained attached to this model: trauma / repression / forgetting / symptom / remembering / healing. In 1937, in "Analysis Terminable and Interminable," he went so far as to say that, like hysterics, psychotics also suffer from reminiscences, implying that certain delusional representations were, in fact, the reappearance in consciousness of past experiences unrecognized as such. Between Anna O. and this late text, Freud's entire body of work is sprinkled with thoughts along these lines. In "Remembering, Repeating and Working-Through" (1914g), for example, he resolved the conflict between impossible access to memory and the sterility of repetition through the introduction of what he called "working through" (*Durcharbeitung*). Further proof is found in his "A Disturbance of Memory on the Acropolis" (1936a), in which Freud displaces the memory trauma (thinking the Acropolis did not exist) onto another type of fact (fear of surpassing the father). The "search for lost time," the attempt to alleviate repression that has produced a failure of memory and the associated symptom, is one of the major themes of Freudian psychoanalysis. However, reservations are in order regarding its originality and theoretical scope.

Even though Freud often felt that the cure for hysterical symptoms through recollection of repressed traumatic memories could be presented as a revolutionary discovery, such figures as Janet and other late nineteenth-century psychotherapists viewed the idea and even the method as commonplace. The idea can even be traced back much further. For example, in a letter to Pierre Chanut, dated June 6, 1647, René Descartes recounts that his penchant for girls with a squint came to an end with his recollection of a childhood memory. Descartes's interest in such women may not have been a true hysterical symptom, but the link

between current behavior and its origin in the past is indicated along with all the characteristics (forgetting, unconsciousness, healing through remembrance) that Freud would later employ. Much earlier, Plato, in the *Phaedrus*, interpreted the process of falling in love in a similar manner. In short, there is no end to the number of literary, philosophical, and clinical sources for what is often considered the most significant psychoanalytic contribution to the theory of memory.

More plausibly, psychoanalysis lent to a certain type of amnesia and memory retrieval an unanticipated practical (therapeutic) scope. Its importance was practical. Although it constitutes an original theoretical point, it does not amount to a global theory such as those developed by philosophers and psychologists. However, it has a good fit with such theories. It works, for example, within the framework that Henri Bergson described and interpreted in *Matter and Memory*.

YVON BRÈS

*See also:* Amnesia; Autohistorization; Character formation; Conscious processes; Day's residues; Deferred action; Dementia; Disavowal; Facilitation; Fantasy, formula of; Forgetting; Historical reality; History and psychoanalysis; Memory; Mnemic trace/memory trace; "Project for a Scientific Psychology, A"; Psychology and psychoanalysis; "Recommendations to Physicians Practicing Psychoanalysis"; Remembering; "Remembering, Repeating and Working-Through"; Reminiscence.

### Bibliography

- Bergson, Henri. (1896). *Matter and memory*. New York: Zone Books, 1988.
- Freud, Sigmund. (1891b). *On aphasia; A critical study*. New York: International Universities Press, 1953.
- . (1900a). The interpretation of dreams. Part I, *SE*, 4: 1–338; Part II, *SE*, 5: 339–625.
- . (1914g). Remembering, repeating and working-through (Further recommendations on the technique of psycho-analysis II). *SE*, 12: 145–156.
- . (1925a). A note upon the "mystic writing pad." *SE*, 19: 225–232.
- . (1936a). A disturbance of memory on the Acropolis. *SE*, 22: 239–248
- . (1937c). Analysis terminable and interminable. *SE*, 23: 209–253

**MEMORY TRACE.** See Mnemic trace**MENG, HEINRICH (1887–1972)**

Heinrich Meng, the German physician, professor, and psychoanalyst was born in Hohenhurst, Germany, on July 9, 1887, and died in Basel, Switzerland on August 10, 1972.

When he was two years old he contracted poliomyelitis and very nearly died from it. Throughout his life he manifested a disposition to be useful to others; while still a student he took an interest in nutrition and physiology. He was vegetarian and joined youth movements to promote temperance, popular education, social and mental hygiene, socialism, and pacifism.

When he finished his medical studies (1907–1911) he practiced in Stuttgart. During World War I he came into contact with Karl Landauer, a psychoanalyst from Frankfurt. In 1921 he went into analysis with Paul Federn in Vienna, followed in 1922 by a second analysis with Hanns Sachs in Berlin. In 1923, thanks to the influence of Clara Zetkin, he was summoned along with other physicians to Lenin's bedside in the Kremlin. From 1929 to 1933 he and Landauer managed the Frankfurt Psychoanalytic Institute (FPI) in association with the Institute for Social Research, which they co-founded. In 1933 he emigrated to Switzerland and in 1937 he acquired the first university chair of "mental hygiene" in Europe. He occupied the chair until his retirement in 1956.

In collaboration with Federn, Meng edited the *Psychoanalytisches Volksbuch* (1926, a popular manual of psychoanalysis) and co-edited the *Zeitschrift für Psychoanalytische Pädagogik* (Magazine of psychoanalytic pedagogy; 1926–1937). He manifested his interest in psychoanalytically-informed mental hygiene through many publications, also editing the *Praxis der seelischen Hygiene* (The practice of mental hygiene; 1943) and *Psychohygienische Vorlesungen* (Conferences on mental hygiene; 1958). He published his major work on psychosomatic questions with Louis R. Grote: *Über interne und psychotherapeutische Behandlung der endogenen Magersucht* (Contribution to the internal and psychotherapeutic treatment of endogenous anorexia; 1934) and developed the concept of *Organpsychose* (organic psychosis). His autobiography, *Leben als*

*Begegnung* (Life as encounter; 1971) played an important role in the history of psychoanalysis in Germany.

Meng's many publications contributed greatly to popularizing psychoanalysis in Germany. By means of subtle influences he managed to have the city of Frankfurt attribute the Goethe prize to Sigmund Freud in 1930 (Plänklers, 1996). In Switzerland he was the pioneer of psychoanalytically-informed mental health praxis.

AUTHOR NAME

See also: Germany; Goethe Prize; Sigmund Freud Institute; Switzerland (German-speaking); *Zeitschrift für psychoanalytische Pädagogik*.

**Bibliography**

- Federn, Paul, and Meng, Heinrich. (1928). *Das psychoanalytische Volksbuch*. Stuttgart: Hippokrates.
- Grote, Louis R., and Meng, Heinrich. (1934). Über interne und psychotherapeutische Behandlung der endogenen Magersucht. *Schweizerische medizinische Wochenschrift*, 15, 7.
- Meng, Heinrich. (1934). *Strafen und Erziehen*. Berne: Hans Huber.
- . (1958). *Psychohygienische Vorlesungen. Eine Einführung in Theorie und Praxis des seelischen Gesundheitsschutzes*. Basel-Stuttgart: Benno Schwabe.
- . (1971). *Leben als Begegnung*. Stuttgart: Hippokrates.
- Plänklers, Tomas. (1996). Die Verleihung des Frankfurter Goethe-Preises an Sigmund Freud 1930. Die Sitzungsprotokolle des Goethe-Preiskuratoriums. In Tomas Plänklers, et al., *Psychoanalyse in Frankfurt a. M. Zerstörte Anfänge, Wiederannäherung und Entwicklungen* (pp. 254–331). Tübingen: Diskord.
- . (1996). Hygiene der Seele. Heinrich Meng (1887–1972). In Tomas Plänklers, et al.: *Psychoanalyse in Frankfurt a. M. Zerstörte Anfänge, Wiederannäherung und Entwicklungen*, (pp. 109–140). Tübingen: Diskord.

**MENNINGER CLINIC**

The Menninger Clinic is an international facility for mental-health treatment, education, research, and prevention. It was started in 1925 by Dr. Charles Frederick, Karl A. Menninger, and his two sons, Karl and Will Menninger out of a small farm house on the outskirts of Topeka, Kansas. In the 1930s a small group of highly dedicated clinicians began to develop methods of applying psychoanalytic ideas to hospital

treatment. By 1942 the Topeka Institute for Psychoanalysis was founded as part of the Menninger Clinic.

After World War II the psychiatric residency program at the Menninger Clinic greatly expanded, with the result that the center became a major training site for American psychiatry. More than 2,000 mental-health professionals have graduated from Menninger training programs. As the Clinic developed, research became a high priority. The Menninger Psychotherapy Research Project, for example, was a seminal investigation of the outcome of psychoanalysis and psychoanalytic psychotherapy.

As Menninger clinicians became increasingly sophisticated at applying psychoanalytic principles to hospital treatment, the clinic became internationally known as a tertiary-care referral center for treatment-refractory patients. Patients came from all over the world for extended hospital treatment with an intensive psychoanalytic focus.

The Menninger Clinic continues to be rated as one of the best two or three psychiatric hospitals in the United States. While a psychoanalytic perspective is still at the core of its treatment philosophy, clinicians have integrated modern psychopharmacologic approaches into their psychotherapeutic efforts. Largely because of the influence of the managed-care movement within the United States, patients who come to the Menninger Clinic stay in the hospital for much shorter periods. As inpatient services have contracted, the clinic's partial-hospitalization and outpatient services have expanded.

The Topeka Institute for Psychoanalysis continues to thrive as part of the Menninger Clinic. Training programs for psychiatry residents, postdoctoral psychology fellows, and post-master's social-work fellows are a central part of the facility. Also flourishing at the clinic are psychoanalytically oriented research programs on the psychotherapy process and outcomes and on child development.

The Menninger Clinic provides comprehensive evaluations for patients from all parts of the United States and abroad. The clinic also has specialized treatment programs for trauma survivors, impaired professionals, substance-abuse patients, eating-disorder patients, and chronic psychotics.

GLEN O. GABBARD

*See also:* Blank/nondelusional psychoses; Bornstein, Berta; Devereux, Georges (born Gyorgy Döbo); Ellenberger, Henri Frédéric; Menninger, Karl A.; Norway; Philippines; Racker, Heinrich; Rapaport, David; Rubinstein, Benjamin B.; Stone, Leo; United States; Weiss, Edoardo.

## MENNINGER, KARL A. (1893–1990)

American psychiatrist and psychoanalyst, Karl A. Menninger was born in Topeka, Kansas, on July 22, 1893, and died there on July 18, 1990.

Raised in Topeka, the son of a general practitioner, he was educated at Harvard University Medical School before returning to Topeka to work with his brother and father in the establishment of a psychiatric clinic and a major psychiatric residency training program there, the present-day Karl Menninger School of Psychiatry. He brought many European analysts to the Menninger Clinic to escape Nazi oppression, among them Otto Fenichel, Martin Grotjahn, and Ernst Simmel. He went on to become a leader in psychoanalysis, serving as president of the American Psychoanalytic Association from 1942 to 1943. He founded the Topeka Institute for Psychoanalysis in 1942.

Menninger was a prolific writer. Among his books were *The Human Mind* (1930), which brought psychoanalytic understanding to the lay public, *Man Against Himself* (1938), in which he explored self-destructiveness (and made a compelling case for the validity of Freud's death instinct), *Love Against Hate* (1992), which examined the human capacity to overcome self-destructiveness, and his magnum opus, *The Vital Balance* (1963). He was also intensely interested in the penal system, and in his book *The Crime of Punishment*, he suggested that many convicted criminals needed treatment rather than punishment (1968). His volume, *Theory of Psychoanalytic Technique*, was one of the few books to examine the theoretical underpinnings for the analyst's interventions.

Menninger spent his life as a champion of the underdog. He was a crusader for a variety of causes, including the American Indian, nuclear nonproliferation, neglected and abused children, and penal reform. In 1981 he received the Medal of Freedom, the United States's highest civilian honor, from President Jimmy Carter.

GLEN O. GABBARD

*See also:* Abstinence/rule of abstinence; Self-mutilation in children.



### Bibliography

- Menninger, Karl A. (1930). *The human mind*. New York: Alfred A. Knopf.
- . (1938). *Man against himself*. New York: Harcourt, Brace & World.
- . (1942). *Love against hate*. New York: Harcourt, Brace & World.
- . (1963). *The vital balance: The life process in mental health and illness*. New York: The Viking Press.
- . (1968). *The crime of punishment*. New York: The Viking Press.

## MENTALIZATION

The term *mentalization* is a neologism created to meet the needs of research into psychosomatic phenomena. Used by Édouard Claparède as early as 1928, the term was adopted by Pierre Marty around 1970. Marty has acknowledged that this concept, which has become an established part of psychoanalytic terminology, was born of the need to establish a psychosomatic classification.

The notion was defined on the basis of a hypothetical impoverishment of the mental functions within the framework of the psychosomatic economy. In both theory and practice, it relates to the representational system, including affective ideation. It covers the quantity and quality of the individual's mental representations, the quality of their articulations, bonds, and networks. Mentalization supports fantasies and dream elements, and facilitates associations and the conversion of internal excitations into thoughts.

In terms of the psychosomatic economy, Marty spoke of inadequacy in acquired ideas, of a lack of availability owing to avoidance or repression, and of mental disorganization; three possible origins, then, all associated with a decreased vigor in mental reality. The first is based on violent or unpleasurable affects linked to perceptual memory traces from a very early time that have not been subjected to the mechanisms of repression; the focus here is on unsymbolizable early traumas, offering a possible structural hypothesis for the process of somatization. The second origin involves conflicts that pit ideas with a heavy instinctual charge against early psychic formations. Their nature being modified by censorship, these ideas are in theory stripped of their original affective value. The third origin is mental disorganization, a crucial concept in Marty's approach.

Mentalization is thus closely bound up with the key elements of the deficiency-oriented paradigm reflected in the notions of *operative* and *essential* depression, as well as with the hypothesis of disorganization.

The notion of mentalization has been used to construct a nosological framework, whence such characterizations as "good mentalization," "poor mentalization," and "uncertain mentalization," as well as that "irregularity in mental function" said to play a role in the so-called character neuroses.

ALAIN FINE

*See also:* Character; Character neurosis; Marty, Pierre; Preconscious, the; Psychoanalytic semiology; Stranger; Symptom-formation; Work (as a psychoanalytic notion).

### Bibliography

- Marty, Pierre. (1991). *Mentalisation et psychosomatique*. Paris: Synthélabo.

### Further Reading

- Fonagy, Peter, and Target, Mary. (1998). Mentalization and the changing aims of child psychoanalysis. *Psychoanalytic Dialogues*, 8, 87–114.

## MERLEAU-PONTY, MAURICE (1908–1961)

Maurice Merleau-Ponty, a French philosopher, was born on March 14, 1908, in Rochefort-sur-Mer and died on May 3, 1961, in Paris. A graduate of the École Normale Supérieure, he held a degree in philosophy and a PhD in literature. He taught in the literature department of the University of Lyon, then at the Sorbonne, and he succeeded Louis Lavelle at the Collège de France in 1952. Introduced to existentialism by Gabriel Marcel, familiar with the work of Edmund Husserl, gestalt theory, and the work of Max Weber, he published several important works of philosophy: *The Structure of Behavior* (1963), *The Phenomenology of Perception* (1962), and *Adventures of the Dialectic* (1973), a critique of a certain conception of Marxism. He also left behind the unfinished manuscript *The Visible and the Invisible* (1968), which pointed to a fundamental reorientation in his thinking. Merleau-Ponty occasionally attended Jacques Lacan's seminar and was present at the Journées de Bonneval conference on the unconscious in 1960.

Merleau-Ponty's work touches on psychoanalysis in three different ways. In his early work he was part of a tradition that viewed phenomenology as an integral part of a comprehensive conception of the world and knowledge, as it was represented in experimental psychology by Wolfgang Köhler and Kurt Koffka, in neurology by Kurt Goldstein, and in philosophy by Max Scheler and Georges Pollitzer. Freud's work also played a role, in that it seemed to Merleau-Ponty to be a search for the concrete and a counterbalance to reductionism, which made behavior and experience the sum of discrete elements, arranged *partes extra partes*, within an unacceptable empirical system.

More specifically, in the chapter of the *Phenomenology of Perception* titled "The Body in its Sexual Being," Merleau-Ponty proposes that we conceive of sexuality not as a mixture of representations and reflexes but as a purposeful way of being in the world and an unalterable drama. The sexual history of a person provides the key to that person's life because it expresses synthetically that person's way of being with respect to time and other people. Merleau-Ponty then considers two aspects of Freud's work. One aspect of Freud's work, his theoretical work, Merleau-Ponty felt, was tinged with nineteenth-century scientism and hence made obsolete by a holistic and dialectical conception of being in the world that challenges the causal approach to studying this order of phenomena. Merleau-Ponty finds value in the other aspect of Freud's work, concrete individual research, where symptoms have several meanings, where everything is overdetermined, and where a person's singular history is ultimately incomparable to any other. It is this second aspect that Merleau-Ponty emphasizes.

What Merleau-Ponty frequently referred to as "existential psychoanalysis" represents less a theory and practice based on the work of Ludwig Binswanger than a holistic conception of humans. Here, sexual life retains its specificity while being part of a dialectical relationship with being in the world, a dialectical relationship that binds the body to sexual activity without making sexual activity a supplemental and possibly dissociable part. Such a conception could result in a form of therapeutic practice.

GEORGES LANTÉRI-LAURA

*See also:* Colloque sur l'inconscient; France; Phenomenology and psychoanalysis; Philosophy and psychoanalysis.

## Bibliography

Editors of *Les temps modernes*. (1961). Maurice Merleau-Ponty. *Les temps modernes*, 184–185.

Merleau-Ponty, Maurice. (1962). *Phenomenology of perception* (Colin Smith, Trans.). London: Routledge. (Original work published 1945)

———. (1963). *The structure of behavior* (Alden L. Fisher, Trans.). Boston: Beacon Press. (Original work published 1942)

———. (1968). *The visible and the invisible* (Alphonso Lingis, Trans.). Evanston, IL: Northwestern University Press. (Original work published 1964)

———. (1973). *Adventures of the dialectic* (Joseph Bien, Trans.). Evanston, IL: Northwestern University Press. (Original work published 1955)

---

## METAPHOR

Metaphor is a figure of speech that involves designating one thing with the name of another, a process that is carried out essentially by substituting one term for another.

Metaphor is a fundamental notion that Jacques Lacan introduced in relation to his thesis that "the unconscious is structured like a language." He justified its legitimacy principally by analogy with the Freudian mechanism of "condensation," and more generally in relation to the structure of the formations of the unconscious and the metaphorical process of the Name-of-the-Father.

Lacan proposed the following symbolic formula for metaphor (2002, p. 190):

$$\frac{S}{S'} \bullet \frac{S'}{x} \rightarrow S \left( \frac{1}{S} \right)$$

The Lacanian use of metaphor is founded on the principle of a signifying substitution that promotes the authority of the signifier over that of the signified. In language, metaphorical substitution most often occurs between two terms on the basis of semantic similarity. At the level of unconscious processes, this similarity is not always immediately apparent, and only a series of associations can bring it to light.

Thus Freudian condensation plays a role in the different unconscious formations, such as dreams and symptoms, for example. Just as the unconscious material in dreams, telescoped by condensations, reappears in a meaningless form in the manifest dream content, so the symptom expresses, in reality, something completely different from what it appears to mean.

The metaphor of the Name-of-the-Father, as it was called by Lacan, is based on the same principle—that of the substitution of signifiers. In this case, the signifier of the Name-of-the-Father substitutes for the signifier of the mother’s desire, which thus becomes the object of repression and becomes unconscious.

The “fort/da game” that Freud described (1920g) directly attests to the process of metaphorization and the repression that is linked to it. A relation of signifying substitution is established by the child as soon as they “name” the signifying reference to the father as the cause of the mother’s absences. In addition to the paternal metaphor, which makes it possible, the fort/da game is also inscribed in a double metaphorical process. In itself, the reel is already a metaphor for the mother, and the game of its presence and absence is another metaphor since it symbolizes her departure and return.

JOËL DOR

*See also:* Condensation; Displacement; Forgetting; Formations of the unconscious; Letter, the; Linguistics and psychoanalysis; Matheme; Metonymy; Mirror stage; Name-of-the-Father; Phobias in children; Psychoses, chronic and delusional; Signifier; Signifier/signified; Signifying chain; Symptom/sinthome; Topology.

### **Bibliography**

Dor, Joël. (1998). *Introduction to the reading of Lacan: The unconscious structured like a language* (Judith Feher Gurewich and Susan Fairfield, Eds.). New York: Other Press, 1998.

Freud, Sigmund. (1920g). Beyond the pleasure principle. *SE*, 18: 1–64.

Lacan, Jacques. (2002). *Écrits: A selection* (Bruce Fink, Trans.). New York: W. W. Norton.

---

## **“METAPSYCHOLOGICAL SUPPLEMENT TO THE THEORY OF DREAMS, A”**

Freud seems to have composed this text, as well as “Mourning and Melancholia,” between April and May of 1915, according to James Strachey (*SE* 14), but neither was published until he was done “putting my final touches” on them (letter to Karl Abraham of 11 November, 1917). In the article he had fewer new things to say on the subject of the dream, than on its role as the guardian of sleep, and on how to integrate

it into his most recent theoretical positions. He planned to set out a synthetic view of these positions subsequently, in twelve metapsychological essays.

Freud suggests that the wish to sleep conducts the libido through a “temporal regression” to a selfish state close to primal narcissism, and the ego to the stage of the hallucinatory realization of wish. In this way he returned to the question he had raised from 1895 in *Project for a Scientific Psychology* (1950a): how to differentiate fantasy, delirium, and external reality? The feeling of conviction afforded by the dream prompts a hallucinatory psychosis: “The process, begun in the *Pcs.* and reinforced by the *Ucs.* pursues a backward course, through the *Ucs.* to perception, which is pressing upon consciousness,” (1916–1917f [1915], p. 227) realizing consequently a “formal regression.” However the dream is differentiated from states like the amentia of Meyner or the hallucinatory phase of schizophrenia, whose mechanisms are close to it, since “reality-testing,” one of “the major institutions of the ego,” (1916–1917f [1915], p. 233), persists in the dreamer.

This text, which is still linked to the formulations of the first topic, pursues the discussion begun in “Formulations on the Two Principles of Mental Functioning” (1911b) on the rapport between the psyche and external reality—which Freud continued to elaborate on in “Neurosis and Psychosis” (1924b) and “Fetishism” (1927e). His growing interest in the functions of the ego can be perceived in the differential explication he gave: Psychotic hallucinations do not occur until the “disintegrated” ego has become incapable of exercising its function of reality-testing, so they can, on no account, be interpreted as early symptoms.

Freud concluded his article by emphasizing the importance of the topic of repression for understanding psychic disorders: “In dreams the withdrawal of cathexis (libido or interest) affects all systems equally; in the transference neuroses, the *Pcs.* cathexis is withdrawn; in schizophrenia, the cathexis of the *Ucs.*; in amentia, that of the *Cs.* (1916–1917f [1915], p. 235).

ALAIN DE MIJOLLA

*See also:* Absence; Amentia; Day’s residues; Dream; Narcissistic withdrawal; Negative hallucination; Projection; Psychoanalytical nosography; Reality testing; Regression; Representability; Sleep/waking; Somnambulism; Wish, hallucinatory satisfaction of a.

### Source Citation

Freud, Sigmund. (1916–1917f [1915]). Metapsychologische Ergänzung zur Traumlehre. *Internationale Zeitschrift für ärztliche Psychoanalyse*, 4, p. 277–287; *GW*, X, p. 412–426; A metapsychological supplement to the theory of dreams. *SE*, 14: 222–235.

### Bibliography

Freud, Sigmund. (1911b). Formulations on the two principles of mental functioning. *SE*, 12: 213–226.

———. (1924b). Neurosis and psychosis. *SE*, 19: 147–153.

———. (1927e). Fetishism. *SE*, 21: 147–157.

———. (1950a). Extracts from the Fliess papers. *SE*, 1: 173–280.

## METAPSYCHOLOGY

The concept of metapsychology was created by Freud to refer to the most theoretical and abstract elements of psychoanalysis. It consists of a set of laws, principles, and fundamental concepts used to represent and describe the operation of the mental apparatus in three fundamental structural aspects: dynamic, topographical, and economic.

The term itself appeared early in Freud's work and is found in a letter to Wilhelm Fliess. It was most likely coined by analogy with the philosophical term "metaphysics," which Freud proposed to "transform . . . into a metapsychology" (1901b, p. 259). The meaning of the concept was gradually refined, and in 1915 Freud attempted to provide a systematic metapsychological description of his current model of psychic structure. The "witch," as he liked to call this metapsychological description, consisted of a set of principles (like the pleasure-unpleasure principle) and hypotheses (such as hypotheses about repression and the unconscious) that presented the functioning of the mind and the processes responsible for its organization as a coherent and intelligible whole.

Freud suggested "that when we have succeeded in describing a psychical process in its dynamic, topographical and economic aspects, we should speak of it as a *metapsychological* presentation" (1915e, p. 181). The economic viewpoint considers the psychic apparatus as crisscrossed by forces that tend toward resolution. The dynamic viewpoint examines how those forces are constructed and how they negotiate mutual conflicts. The topographical viewpoint assumes that we can

describe the psychic apparatus as a space where different areas can be delimited (conscious, preconscious, unconscious), these being governed by laws and intersected by specific processes (unconscious primary processes and preconscious secondary processes). These three viewpoints in combination can present these processes in light of how they are cathected, the role they play in mental organization, and the effect they have on the course of psychic events.

Freud also suggested adding a fourth viewpoint, the genetic, to the first three, which are structural. Freud's proposal, admittedly never fully developed in his work, was given little consideration in French psychoanalysis. But especially in America, writers such as Ernst Kris, Rudolph M. Loewenstein, and Heinz Hartmann have incorporated the notion into ego Psychology. Other authors feel that the three structural viewpoints should be contrasted with a historical viewpoint, which, though not "genetic" in the strict sense, comprises the notion that the psychic processes undergo historical development and organization.

The overall organization of Freud's metapsychology underwent a change of direction in 1920 with the movement "beyond the pleasure principle" to a compulsion to repeat. This turning-point of 1920 led to a "second topography." This new system, also known as the "structural model," does not overlap with the earlier arrangement of conscious, preconscious, and unconscious point by point. Instead, it divides the psychic apparatus into ego, superego, and id. This topographical change entailed a theoretical reorganization so broad that it may be considered a "second metapsychology." Some authors maintain that the introduction in 1937 of the process of splitting introduced a "third metapsychology."

A dialectic existed in Freud's work between metapsychology and clinical practice: the identification of new clinical facts would bring about a corresponding evolution in metapsychology, and this in turn had an affect on theoretical-clinical description. Although the foundations of metapsychology are well established, there is no reason to believe that it is incapable of change and enrichment from advances in clinical knowledge, just as it may evolve through metapsychological research papers.

Metapsychology is the most fundamental component of psychoanalytic theory, the component that consolidates the most essential elements of a psychoanalytic conception of mental functioning. This is

what makes it a metapsychology, that is, a second-level psychology with direct bearing on the processes that govern individual psychologies, a theory that enables us to account for specific clinical variations, using general and universal principles and processes. By abstractly describing processes of ordering, classification, displacement, and condensation (the transformations of psychic reality), metapsychology overcomes the paradox of a theory applied to itself. It defines a process of theorization that, in its movement and mutations, successfully averts the risk of self-validation that its reflexivity might bring about.

Early twenty-first century debates with detractors who refuse to grant metapsychology the status of a rigorous theory and with some psychoanalysts who claim to be able to do without “the witch” and her claims in their daily clinical work center around this fundamental theoretical status. But to reject the status of metapsychology within psychoanalysis amounts to eliminating the most fundamental element of its contribution to depth psychology.

RENÉ ROUSSILLON

*See also:* Dynamic point of view, the; Economic point of view, the; First World War: The effect on the development of psychoanalysis; “Instincts and their Vicissitudes”; “Repression”; Topographical point of view, the; Witch of Metapsychology, the.

### **Bibliography**

- Freud, Sigmund. (1915e). The unconscious. *SE*, 14: 159–204.
- . (1920g). Beyond the pleasure principle. *SE*, 18: 1–64.
- Oppenheimer, Agnès. (1985). Qu'est-ce que la métapsychologie. *Revue française de psychanalyse*, 49 (5), 1197–1216.
- Roussillon, René. (1995). La métapsychologie des processus et la transitionnalité. *Revue française de psychanalyse*, 59 (special number), 1351–1519.

### **Further Reading**

- Gill, Merton. (1988). Metapsychology revisited. *Annual of Psychoanalysis*, 16, 35–48.
- Loewald, Hans W. (1988). In search of nature: Metapsychology, metaphysics, projection. *Annual of Psychoanalysis*, 16, 49–54.
- Rubinstein, Benjamin B. (1996). Why metapsychology? *Psychological Issues*, 62, 485–496.

Zepf, Siegfried. (2001). Incentives for a reconsideration of the debate on metapsychology. *International Journal of Psychoanalysis*, 82, 463–484.

## **METONYMY**

Metonymy is a figure of speech that involves transferring a name from one thing to another on the basis of certain typical kinds of relations: designating the effect with the cause, the whole with a part, the contents with its container. An example would be “a sail on the horizon” for “a ship on the horizon.”

Metonymy is a fundamental notion supporting Lacan's thesis that “the unconscious is structured like a language.” It is analogous with the Freudian concept of “displacement” and refers to the problematic of desire and demand.

Lacan (2002, p. 155) proposed the following symbolic formula for metonymy:

$$f(S \dots S') S \equiv S(-) s.$$

This formula represents the fact that any new signifier ( $S'$ ) intervenes because it is contiguous with a prior signifier ( $S$ ). Metonymy is best illustrated by the kind of displacement that takes place in dreams.

The Freudian concept of displacement emphasizes the shift of value and of meaning. What usually happens is that words and feelings, in a distorted and disguised form, are transferred to nearby material. Lacan insisted that metonymy resists being meaningful by always producing apparent nonsense, as is usually the case with the manifest content of a dream.

Primal repression and the metaphor of the name of the Father impose the mediation of a signifier upon desire. The signifier of the name of the Father initiates the alienation of desire in language. Desire can no longer operate directly. Insofar as it takes the form of speech and is expressed as demand, desire becomes nothing more than a reflection of itself. Increasingly lost in the chain of signifiers, desire refers to an indeterminate series of objects, one after another, that are substitutes for the lost object (*das Ding*), and thus it refers to an indeterminate series of signifiers that symbolize these substitutive objects.

Desire always refers to something fundamentally other than the objects it aims for or the signifiers that symbolize them. Thus desire inevitably follows the

path of metonymy. Because desire is expressed by a symbolizing demand, it always designates a desire for the whole (the lost object) by expressing a desire for a part (the substitute object), just as the metonymic figure “a sail on the horizon” designates the whole (a ship) by a part (a sail).

JOËL DOR

See also: Metaphor; Want of being/lack of being.

### Bibliography

Dor, Joël. (1998). *Introduction to the reading of Lacan: The unconscious structured like a language*. New York: Other Press.

Lacan Jacques. (1993). *The seminar of Jacques Lacan. Book 3: The psychoses* (Russell Grigg, Trans.). New York: W. W. Norton. (Original work published 1981; originally presented 1955–1956)

———. (1998). *Le séminaire. Book 5: Les formations de l'inconscient, 1957–1958*. Paris: Seuil.

———. (2002). *Écrits: A selection* (Bruce Fink, Trans.). New York: W. W. Norton.

## MEXICO

During the XX International Psychoanalytical Association (IPA) Congress in Paris in 1957, the Asociación psicoanalítica mexicana (APM; Mexican Psychoanalytic Association) became the first official Mexican affiliate of the IPA. Since that time, the Mexican Psychoanalytic Association has played a substantial role in the IPA: three IPA vice presidents have been from the Mexican Psychoanalytic Association, as have several members serving on nominating committees and on sponsoring committees within the IPA. The Mexican association has also had three members serve as president of the Federación psicoanalítica de América latina (FePAL; Psychoanalytic Federation of Latin America).

In the past, inadequate local training conditions in Mexico had sent many psychiatrists to Argentina, and also to the United States and France, countries that benefited when analysts fleeing from the Nazis enriched existing psychoanalytic training programs. The return of these now-trained analysts to Mexico produced transitory tensions with psychiatrists who had remained in Mexico. Their circumstantial encounter with Erich

Fromm, who had come to Mexico only for his wife's health, diminished tension, as he helped to fulfill their needs for training, founding the Mexican Institute of Psychoanalysis.

The founding group of the Mexican Psychoanalytic Association included Santiago Ramirez, Ramón Parres, José Remus, Avelino González, José Luis González, and Rafael Barajas all of whom were training analysts. Victor Aíza, Fernando Cesarman, Luis Féder, Estela Galván Remus, and Francisco González Pineda were initially included as candidates, were later incorporated into the founding group of members. Carlos Corona and Alfredo Namun eventually joined the Association. Santiago Ramirez and Parres pioneered psychoanalytical training in México City; Rafael Barajas in Monterrey. Successive generations and study groups included other important researchers in theoretical and applied fields.

Initially all doors and roads seemed closed. Though the Hospital General was blocked as a project for psychiatric training, eventually the Hospital Central Militar, Hospital Infantil, Universidad Nacional Autónoma de México Psychology faculty, and the Instituto Nacional de Pediatría, among others, opened their institutions to psychoanalytic training. After one year, the Mexican Psychoanalytic Association's influence spread to other medical and psychological spheres and to all disciplines, covering most socioeconomic and cultural levels within Mexico. The flow of patients with careers in the arts and sciences was remarkable. Mexican authors produced close to 3,000 articles in the Mexican Psychoanalytic Association's *Cuadernos de Psicoanálisis* (begun in 1965), in books, and in other national and international psychoanalytical journals.

The unexpectedly high demand for treatment oversaturated the available capacity, spawning large populations of self-appointed psychoanalysts and psychotherapists. From 37 groups studied that called themselves psychoanalytic, few had earned the name, a consequence of the continuing lack of international, regional or even national regulation of psychoanalysis as a career and title.

An anti-establishment psychoanalytic left “*Plataforma*” emerged during the turbulent mid-1960s. The Viennese-Argentine Marie Langer led a fight from Mexico, which spread throughout Latin America, against “ultra-rightist” Institutes. But the *Plataforma* soon disappeared. Some present Lacanian psychoanalysts are former *plataforma* members.

“L’Asociacion Regiomontana de Psicoanalisis”, (ARPAC), is another psychoanalytic society, equivalent to the Mexican Psychoanalytic Association. It was founded in 1979 to serve the northern part of the country by a group of Monterrey Mexican Psychoanalytic Association members, including Diego Rodriguez, Roger Garcia, Alfonso Moreno Robles, Ruben Hinojosa and Ruben Tames. The founding members were later joined by Ricardo Diaz Conti, Cesar Garza and Hernan Solis. In 1993, the IPA recognized ARPAC as an independent affiliate.

As of 2005, the Association had 130 members and 22 candidates. Mexico City also suffers a consumer’s crisis; patients who once averaged 3 to 4 visits a week only average 2 sessions as of the early 2000s. Peripheral groups are developing including Jungians, local and foreign Lacanians. The Mexican Psychoanalytic Association began to provide distance education and new projects for fellowships for each state were being considered. Josefina Mendoza was president of the Mexican Psychoanalytic Association in 2005. The Institute of the Asociación Psicoanalitica Mexicana has had over 20 graduating classes. Its post-graduate programs include training analysis and child psychoanalysis. Its post-graduate center also trains psychoanalytically-oriented psychotherapists. The Mexican Psychoanalytic Association has a full extension program and participates in applied psychoanalytic activities along with study groups, research, publishing, and two yearly congresses (one open, one closed).

The Association inspired and developed groups all over the country. Some of the groups in Mexico City include AMPAG—Analytic Group Therapy Association (founded by L. Feder, J. L. Gonzalez, G. Quevedo, F. Zmudt. Graduates: first generation, A. Palacios, H. Prado); IMPPA (Armando Barriguete); and Asociacion Mexicana de Psychoanalytic Psychotherapy, founded by Santiago Ramirez, Dolores Sandoval, and others. In Guadalajara, there are two groups: GGPP (Varela and Gramajo) and APJ (Torres and Manuel Fernandez V.). There are nearly 10 other groups in other parts of Mexico. There are individuals practicing in Yucatan, Chiapas, Guadalajara, Cuernavaca, Aguascalientes, and Vera Cruz. Specialized psychoanalytic institutions and hospital services include IFAC (Family Therapy Institute), which provides family therapy, merging psychoanalytical and Frommian orientations; CPPO, bringing distinguished lecturers; and IMANTI, which provides special education.

Some of the contributions to psychoanalytical thought include the following: psychology of the Mexican (Santiago Ramirez); aggression and destructivity of the Mexican (González Pineda); studies on transference-countertransference (José Remus, Luis Féder); mammoth group psychotherapy (José Luis González); separation anxiety (Avelino González); child analysis (Victor Aiza, M. I. López; M. Salles, child psychiatry); ecocide and non-human objects relations (Fernando Cesarman); and the “unwanted child” developed into preconceptology theory and psychogenoma project (L. Féder team of J. Islas, R. Balderas, S. Weinstein). Significant training contributions have been made by Eduardo Dallal, M. A. Dupont, Jaime Ayala and José Camacho. Recent awards suggest that Mexico’s creative and pioneering fervor continues into the twenty-first century.

LUIS FÉDER

### **Bibliography**

- Féder, Luis and Marco A. Dupont. (1987). Aspectos de la siembra y cosecha psicoanalítica mexicana, *Correio da Fe.P.A.L.*, 97.
- Parres Ramón and Santiago Ramírez. (1966). Historia del movimiento psicoanalítico en México. In Fr. Alexander, S. Eisenstein, and M. Grotjahn (Eds.), *Psychoanalytic Pioneers*. New York and London: Basic Books.

---

### **MEYER, ADOLF F. (1866–1950)**

Adolf Meyer was born on September 3, 1866, in Niederweningen, a small village near Zurich, Switzerland, and died on March 17, 1950, in Baltimore, Maryland. An early, influential psychiatrist, Meyer was one of the founders of the New York Psychoanalytic Society and of the American Psychoanalytic Association.

Son of a Zwinglian minister, Meyer studied medicine in Zurich, where he was student of Auguste Forel at the Burghölzli Mental Hospital. He also studied in England with Hughlings Jackson and in Paris with Jean Martin Charcot.

In 1892 Meyer emigrated to the United States. He worked at the Illinois Eastern Hospital for the Insane, then at the Worcester Lunatic Hospital, in Massachusetts. From 1902 he practiced at the New York State Pathological Institute of Manhattan. There he joined early informal meetings about psychoanalysis. From 1904 to 1909 Meyer served as professor of psychiatry

at Cornell Medical School. He began teaching his original views concerning dementia praecox (schizophrenia), taking a broader view of its etiology and prognosis than was common at the time. (The Emil Kraepelin tradition of psychiatry viewed dementia praecox as an organic disease without possibility of cure.) In 1909 Meyer lectured on the dynamics of this disease at Clark University's twentieth anniversary jubilee, in which Freud also took part. In 1910 he became the first psychiatrist appointed to a chair at Johns Hopkins University, where he taught until 1941. And in 1913 he was named director of the university's new Henry Phipps Psychiatric Clinic.

At a time when knowledge about the brain was highly limited, Meyer deemphasized organic factors in such severe mental disorders as schizophrenia, in favor of a functional typology. His *Psychobiology: A Science of Man*, published posthumously in 1957, represents in part the influence of Hughlings Jackson's biological approach to neurology; Meyer had studied Jackson's institute in London in 1891. (In Meyer's usage, *psychobiology* adumbrates but is far short of the contemporary discipline of the same name.) Downplaying efforts to link behavior to brain lesions or neurological abnormalities, Meyer attempted to relate specific disease states to conscious emotions, linking even severe disorders to a patient's experience and habitual reactions. Meyer did not view schizophrenia, for example, as an untreatable illness with a fatal prognosis, as was common in Kraepelinian psychiatry. He suggested instead that dynamic factors could lead to debilitating mental disease, and he advocated treating individual patients in private practice. This viewpoint, because it saw psychotherapy as offering optimistic prognoses, helped introduce psychoanalytic thinking into psychiatry and extend its influence in the field from the mid-twentieth century.

Meyer was also a key figure in the mental-health movement in the United States. Psychiatrists and neurologists were formerly largely limited to practicing in mental institutions. Meyer advocated employing psychiatrists in schools, prisons, and a variety of community and workplace settings. He thus was instrumental in vastly expanding the role of psychiatrists.

ELKE MÜHLEITNER

See also: Burghölzli asylum; Japan; United States.

### **Bibliography**

- Bonin, Werner F. (1963). *Die grossen Psychologen*. Düsseldorf, Germany: Econ Taschenbuch.
- Hale, Nathan G. (1995). *The rise and crisis of psychoanalysis in the United States*. New York: Oxford University Press.
- Leys, Ruth. (1990). Adolf Meyer: A biographical note. In Ruth Leys and Rand B. Evans (Eds.), *Defining American psychology: The correspondence between Adolf Meyer and Edward Bradford Titchener*. Baltimore, MD: Johns Hopkins University Press.
- Meyer, Adolf. (1950–1952). *Collected papers of Adolf Meyer* (4 vols.). Baltimore, MD: Johns Hopkins Press.
- . (1957). *Psychobiology: A science of man*. Springfield, IL: Thomas.

---

### **MEYERSON, IGNACE (1888–1983)**

Ignace Meyerson, a French physician and psychologist, was born in Poland on February 27, 1888, and died in Paris on November 17, 1983.

Having been active in the Russian-Polish insurrection of 1905, he arrived in Paris in 1906 and met up with his uncle, Émile Meyerson, a philosopher and historian of science. From 1907 to 1920 he studied medicine, the natural sciences, philosophy, and sociology. During World War I he replaced Henri Wallon, who was serving at the front, under Chaslin and Nageotte at the Salpêtrière. He got to know Pierre Janet and Georges Dumas and became Dumas's assistant in the psychology laboratory of the Saint Anne asylum.

At the request of Dumas and publisher, Félix Alcan he started to translate the *Traumdeutung* (Freud, 1900a, *The Interpretation of Dreams*) in 1922. As odd as it is that Freud allowed his book of dreams to be translated by someone totally unknown, and a student of the man whom he considered to be his most formidable enemy in France, the attraction of being published by Alcan, the most prestigious publisher of academic works, must have had a determining influence.

In spite of his lack of enthusiasm (he never admired psychoanalysis), Meyerson accepted the difficult task, which nevertheless ensured him a comfortable retirement as a result of the gilt-edged contract he negotiated with Alcan (ten percent of the rights). *La Science des rêves* (*The Science of Dreams*) appeared in 1926. It was not republished until 1953, and 1967 saw a new translation published by the Presses Universitaires de



France, revised by Denise Berger and entitled *L'Interprétation des rêves* (The interpretation of dreams).

In 1947 Meyerson presented his PhD thesis, his main written work: *Les Fonctions psychologiques et les œuvres* (Psychological functions and works). In it he presents the bases of his historical psychology as applied to the individual. He then applied for the Sorbonne chair of general psychology, left vacant by Paul Guillaume, but Daniel Lagache was appointed and thus gave a much more clinical orientation to French psychology.

Meyerson died at the age of ninety-five, having abandoned his teaching post in section six of the *École des hautes études en sciences sociales* (EHESS, College of Advanced Studies in the Social Sciences) only a few months earlier. Although he is not credited with having had much influence, Meyerson did have a long-lasting and profound effect on French psychology. For thirty years he was the editor of Janet's and Dumas's *Journal de psychologie normale et pathologique* (Journal of Normal and Pathological Psychology), making it one of the great forums of intellectual expression between the two world wars. He also founded comparative historical psychology in the *École Pratique des Hautes Études* (Practical College of Higher Studies).

ANNICK OHAYON

See also: France; Wish/yearning.

### **Bibliography**

Meyerson, Ignace. (1948). *Les fonctions psychologiques et les œuvres*, thèse pour le doctorat ès-lettres présentée à la faculté des lettres de Paris, 1947. Paris: Vrin.

———. (1987). *Écrits 1920–1983. Pour une psychologie historique*. Paris: Presses Universitaires de France.

Mijolla, Alain de. (1991). L'édition en français des "Œuvres" de Freud avant 1940. Autour de quelques documents nouveaux. *Revue internationale d'histoire de la psychanalyse*, 4, 209–270.

Vermès, Geneviève. (1992). Un rédacteur pour le "Journal de psychologie normale et pathologique": Ignace Meyerson, XIe Meeting annuel de Cheiron, Madrid, septembre 1991. *Revista historia de la Psicología*, 2, 353–359.

## **MEYNERT, THEODOR (1833–1892)**

Theodor Meynert, an Austrian psychiatrist, was born in Dresden in 1833 and died at Klosterneuburg, near Vienna, in 1892.

His father was a writer and his mother a singer at the court opera. Meynert, a "curious mixture of artist and naturalist," became a doctor of medicine in 1861 and in 1865 he presented a thesis that authorized him to teach in third level education: *Bau und Leistungen des Gehirns und Rückenmarks mit Beziehung zu deren Erkrankungen* (Structure and activity of the brain and spinal cord in relation to their pathology). In 1868 his authorization was extended to include psychiatry. An experienced dissector, he was appointed director of a psychiatric hospital in Lower Austria in 1870. By 1873 he occupied a chair of psychiatry and in 1875 he became the director of the psychiatric clinic attached to the University of Vienna.

Meynert's scientific contributions are related to his work on the pathology of the brain, such as mapping the topography of the sensory and motor pathways and identifying the nerve endings in the cerebral motor cortex and the linking pathways of the cerebellum, as well as functional antagonisms that are important for the history of the evolution between the cerebral cortex and the rest of the brain. Meynert is recognized as the founder of the cytoarchitectonics of the cerebral cortex. He devoted himself to establishing psychiatry as an exact science based on anatomy. He formulated the antagonism between the cortex and the sub-cortical zones as being the key to the abnormal function of cerebral mechanisms in mental illness. He left his mark on theories concerning the causal links between cerebral pathologies and psychoses as a result of deficits in cerebral nutrition related to vasomotricity. His article "Amentia" (1890/1983) describes and demonstrates the interaction between organic and psychological factors.

In July 1882, when he entered the general hospital of Vienna as an intern, Freud had already abandoned his career as a researcher with Brücke for financial reasons. Having worked as an assistant physician in Meynert's clinic from May 1 to September 31, 1883, he continued his laboratory research into the anatomy of the brain for another eighteen months. However, his initial high esteem for Meynert was transformed into a critical distance with regard to the "idol Meynert enthroned in the heavens." Meynert later distanced himself from Freud because of the latter's interest and experience with Charcot's ideas in Paris and his therapeutic involvement with hypnotism.

EVA LAIBLE

See also: Absence; "Autobiographical Study, An"; Freud, the Secret Passion; Kantianism and psychoanalysis; *Metapsychological Supplement to the Theory of Dreams*; Vienna General Hospital.

### Bibliography

Freud, Sigmund. (1960b [1885]). Curriculum vitae. In J. Gicklhorn and R. Gicklhorn, *Sigmund Freuds akademische Laufbahn im Lichte der Dokumente*. Vienna: Urvan & Schwarzenberg.

———. (1985c [1887-1904]). *The complete letters of Sigmund Freud to Wilhelm Fliess, 1887–1904* (J. M. Masson Trans. and Ed.). Cambridge, MA: Harvard University Press.

Hirschmüller, Albrecht. (1991). *Freuds Begegnung mit der Psychiatrie*. Tübingen: Diskord.

Lesky, Erna. (1976). *The Vienna Medical School of the 19th Century* (L. Williams and I. S. Levij, Trans.). Baltimore: Johns Hopkins University Press. (Original work published in 1965)

Meynert, Theodor. (1983). L'Amentia, ou confusion. C. Levy-Friesacher (Ed.), *Meynert-Freud "L'amentia"*. Paris: Presses Universitaires de France. (Original work published 1890)

Pappenheim, Else. (1975). On Meynert's Amentia. *History of Medicine*, 9, 3–4.

## MIDLIFE CRISIS

As a major evolutionary stage in middle adulthood, the midlife crisis corresponds to a change, a transition, or an existential turning point that is not necessarily pathological and takes place somewhere between the ages of thirty-five and fifty.

Based on a more or less deep questioning of oneself it may contribute to the possible emergence of psychopathological disturbances that in all probability stem from the personal history and constitution of each person (depressive reactions, suicide or attempted suicide, manic or hypomanic defenses, and psychotic outbursts). Somatic complaints may also often come to the fore.

From a psychopathological point of view, the midlife crisis has its roots in a complex interweaving of different biological, psychological, and social factors. Some Anglo-Saxon authors (among them Elliott Jaques and Daniel J. Levinson) have studied the factors that may contribute to the fragility of the mind; in particular reduced physical performance, the approach of

menopause in women, or a painful awareness of the time that has already passed.

From a psychodynamic point of view a role may be attributed to the reverse parental identification with the children, who are approximately going through adolescence when their parents are having their midlife crisis. These reverse identifications run an implicit risk of causing depressive moods by virtue of the fact that they are based on an existential impasse.

In relation to the midlife crisis it is worth referring to Carl Gustav Jung's already quite old writings, particularly the article titled *The Stages of Life*. Having described the "archetypes" that constitute the collective unconscious (the true substrate of the psyche, an immutable structure, a sort of symbolic heritage that is proper to all humanity), Jung then went on to complete this view of the psyche with the notion of "psychological types." Here he described individual characters that are organized around the introversion/extroversion dialectic and are centered by a process of individuation that leads the human being toward a unification of the personality through a series of metamorphoses or stages, among which the midlife crisis occupies a relatively important position.

The concept of crisis has lost some of its importance in modern psychopathological writing both in relation to adolescence and to this midlife period that is sometimes called *maturescence* and then considered to be a sort of second adolescence or a third phase in the separation-individuation process. Nowadays we tend to lay more stress on the processes of psychic mutation or transformation with reference to the concept of "catastrophic change" (René Thom), but without the harmful aspect that is often associated with the term *crisis*.

BERNARD GOLSE

See also: Catastrophe theory and psychoanalysis; Horney-Danielson, Karen; Psychobiography.

### Bibliography

Jaques, Elliott. (1965). Death and the mid-life crisis. *International Journal of Psycho-Analysis*, 46, 502–514.

Jung, Carl Gustav. (1930). The stages of life. In *Modern man in search of a soul*. New York: Harvest Books.

Levinson, Daniel J. (1978). *The seasons of a man's life*. New York: Ballantine Books.

Millet, L., Pon, J., and Millet-Bartoli, F. (1994). *La crise du milieu de la vie*. Paris: Masson.

Porot, Antoine. (1952). *Manuel alphabétique de psychiatrie*. Paris: Presses Universitaires de France.

### Further Reading

Ellman, Jon P. (1996). Analyst and patient midlife. *Psychoanalytic Quarterly*, 65, 353–371.

Segal, Hanna. (1984). Joseph Conrad and the mid-life crisis. *International Review of Psychoanalysis*, 11, 3–10.

---

## MINKOWSKA-BROKMAN, FRANÇOISE (1882–1950)

Françoise Minkowska-Brokman, a physician and psychiatrist, was born on January 22, 1882, and died in Paris on September 15, 1950.

From a Polish Jewish family, she was prevented by the czarist régime from studying medicine within the Russian empire, as was her future husband, Eugène Minkowski. She studied under Eugen Bleuler in the Burghözli asylum in Zürich, and then she went to Kazan in 1909 to acquire a diploma that would allow her to work in Russia at the same time as Eugène Minkowski, whom she married on her return.

In Zürich she also met Hermann Rorschach, another of Bleuler's students, who also considered moving to Russia because of his marriage to Olga Stempelin. Minkowska was therefore familiar with the ideas of the inventor of the famous Rorschach test well before the publication of his *Psychodiagnostics* in 1921.

Although she had lived in France for several years, after World War I her family responsibilities prevented her from resuming her studies in order to practice medicine there. Her research work in Paris was therefore conducted independently of any official organization. In 1925 she contributed to the collective publication *L'Évolution psychiatrique* with *Les troubles essentiels de la schizophrénie dans leurs rapports avec les données de psychologie et de la biologie moderne* (The relationship between essential schizophrenic disorders and modern psychology and biology), and again in 1927 with *Le problème de la constitution examinée à la lumière des recherches généalogiques et son rôle théorique et pratique* (The problem of the constitution examined in the light of genealogical research and its theoretical and practical role). She was referring to

Kretschmer's morphopsychological distinction (in *Körperbau und Charakter*, [Physique and character; 1921]) between schizoid and cycloid. In the same vein, she described a third type of constitution or personality structure as epileptoid or, to be more precise, *glischroid*, a term chosen by Édouard Pichon. Having read Jaspers's study of Van Gogh, she took an interest in the painter's life and work and came to the conclusion that glischroid epilepsy was the psychopathological register that best corresponded to the painter's psychiatric experiences.

Minkowska's untimely death prevented her from completing a study of the Rorschach test, but a collection of her papers was published posthumously in 1956. Seven of them had been published between 1940 and 1950 in *Annales médico-psychologiques*, *L'Évolution psychiatrique* and *Le Journal de psychiatrie infantile*. Study number 2, dating from 1943, was banned in France but made its way clandestinely to be published in *Rorschachiana* in 1945. The remaining two studies have never been published. They were: *Le Rorschach en tant que "Formdeutungsversuch"* (The Rorschach as an attempt to interpret form; Françoise Minkowska preferred this expression to "test"), presented on the occasion of the First International Rorschach conference in Zürich in 1949, and a particularly moving text: the paper she gave on March 20, 1950, written in reaction to a posthumous article by Rorschach reviewing a paper given to the Swiss Society for Psychoanalysis in March, 1922. Her own death on September 15, 1950, did not allow her to review it for publication.

The funeral oration in honor of Minkowska was delivered in the name of *L'Évolution psychiatrique* by Jacques Lacan.

JEAN GARRABÉ

See also: Minkowski, Eugene; Schizophrenia.

### Bibliography

Minkowska, Françoise. (1956). *Le Rorschach. À la recherche du monde des formes*. Paris: Desclée de Brouwer.

---

## MINKOWSKI, EUGÈNE (1885–1972)

Eugène Minkowski, a psychiatrist and philosopher, was born on April 17, 1885, in Saint Petersburg and died on September 15, 1972, in Paris.

Born into a Jewish family from Lithuania, he began his medical studies in Warsaw but, because of political repression from the czarist government, was forced to complete his education in Munich, where he obtained his degree in 1909. To practice in Russia, he sat for another degree in Kazan, where he met Françoise Brokman, whom he married when he returned to Western Europe. Upon his return to Munich, this time to study philosophy, he found himself caught up in the First World War. He initially sought refuge in Zurich, and worked with Eugen Bleuler at the Burghölzli Asylum. He then joined the French army, where he served as a military doctor on the battlefield.

As a result of volunteering for service, Minkowski was made a French national and settled in Paris after the war, where he spent the greater part of his life. He worked as a consultant at the Rothschild Hospital and the Henri-Rousselle Pavilion at Sainte-Anne's Hospital.

In 1926 Minkowski defended his dissertation, "La notion de perte de contact avec la réalité et ses applications en psychopathologie," based on the concept of *élan vital* introduced by Bergson in *Creative Evolution* (1907). He associated this loss of *élan vital* with autism, as Bleuler referred to autoeroticism, a fundamental symptom of the schizophrenic psychoses (1911). It was through Bergson's vision that French psychiatrists approached Bleuler's work, using the new tools of psychoanalysis to revise the concept of dementia praecox constructed by Emil Kraepelin at the end of the nineteenth century.

In 1923 Minkowski published an article that clearly indicated his interest in phenomenology, "Étude psychologique et analyse phénoménologique d'un cas de mélancolie schizophrénique." He also contributed articles to the two collections published as *L'Évolution psychiatrique*: "La genèse de la notion de schizophrénie et ses caractères essentiels" (1925) and "De la rêverie morbide au délire d'influence" (1927). In 1925 Minkowski, together with the analysts who went on to create the Société psychanalytique de Paris (Paris Psychoanalytic Society) the following year, helped found the organization L'Évolution psychiatrique. Minkowski was secretary general of the organization until the Second World War, when the society interrupted its activities. During this period Minkowski made *L'Évolution psychiatrique* a place where French psychiatrists would have access to new information from philosophy and science that contributed to the evolution

of their discipline. Minkowski himself barely escaped deportation during the Occupation.

Minkowski, together with Ludwig Binswanger, is considered the creator of phenomenological psychiatry. *Le Temps vécu, études phénoménologiques et psychopathologiques* (1933) describes the spatialization of being, which compensates for the feeling of time that is no longer experienced in schizophrenia. In April 1938, Minkowski published, in the *Annales médico-psychologiques*, "À propos de l'hygiène mentale: Quelques réflexions," where he protested against the law requiring the sterilization of mentally ill patients with hereditary diseases that was promulgated in Nazi Germany as a form of mental hygiene.

In 1956, *L'Évolution psychiatrique* published a volume dedicated to Eugène Minkowski, with contributions from more than forty authors. Minkowski devoted the end of his life to writing *Traité de psychopathologie* (1966/1999), an important synthesis of his life's work.

JEAN GARRABÉ

*See also:* Colloque sur l'inconscient; *Évolution psychiatrique*, L'; Ey, Henri; France; Minkowska-Brokman, Françoise; Mythomania; Phenomenology and psychoanalysis; Schizophrenia.

### **Bibliography**

- Minkowski, Eugène. (1923) Étude psychologique et analyse phénoménologique d'un cas de mélancolie schizophrénique. *Journal de psychologie normale et pathologique*, 20, 543–558.
- . (1927). *La Schizophrénie*. Paris: Payot.
- . (1933). *Le Temps vécu. Études phénoménologiques et psychopathologiques*. Paris: Payot.
- . (1999). *Traité de psychopathologie*. Paris: Le Plessis-Robinson. (Original work published 1966)

---

## **MINUTES OF THE VIENNA PSYCHOANALYTIC SOCIETY**

Otto Rank, hired as appointed secretary at the age of twenty-two, began drafting the *Minutes of the Vienna Psychoanalytic Society*, along with two small volumes containing papers presented and attendance lists, on October 16, 1906. Until April 27, 1910, he wrote these by hand; the acquisition of a typewriter made it possible

to produce multiple copies thereafter. Rank was mobilized in 1915 and Theodor Reik took over secretarial functions for the society. However, he recorded only paper titles and attendance lists. The next minutes were not produced until November 19, 1918; they recorded a lecture given by Siegfried Bernfeld, the last in the series.

Sigmund Freud kept these minutes, though their existence was for the most part forgotten. Before leaving for London in 1938, Freud entrusted them to Paul Federn. Since 1924, Federn had been Freud's personal representative as well as administrator and vice president of the Vienna Psychoanalytic Society. He took the minutes to the United States and published one set of them in 1947, in volume one of *Samiksa*, the review of the Indian Psychoanalytic Society. His attempts to publish the minutes in their entirety remained fruitless due to lack of money. At the execution of his will in 1950, he bequeathed the publication rights to Hermann Nunberg and his son Ernst Federn.

Editing of the minutes began in 1951, with the help of a five-thousand-dollar loan. The first volume in English, translated from the German by Margarete Nunberg, was published by International Universities Press in 1962; the fourth and final volume appeared in 1975. In German, the first volume was published by S. Fischer Verlag in 1976; the fourth volume, with an afterword by Harald Leupold-Löwenstein, came out in 1981. The English-language edition ends with the 250th set of minutes; the German edition stops in 1918. Both editions include the minutes of Bernfeld's lecture on November 19, 1918, and those of the society's last session on March 20, 1938. The first volume of the French edition, translated by Nina Schan-Bakman, was published in 1976 by Gallimard; the fourth volume appeared in 1983. A first volume, 1906–1908, was published in Italian and in Spanish. The manuscripts were returned to the Vienna Psychoanalytic Society by Ernst Federn, in accordance with Paul Federn's wishes as expressed in one of his letters.

The publication of the Vienna minutes is of the utmost importance for the history of psychoanalysis. There are several areas that the minutes cast in a new light:

- From 1903 on, Freud was by no means as isolated in his research as Ernest Jones described in his autobiography. The men and women who accompanied him at this time belonged to Vienna's intellectual and medical elite; among them were two eminent musicologists, David Back and

Max Graf. Other renowned personalities emerged within the circle of guests.

- The process that led to the split with Alfred Adler in 1911–1913 is clearer.
- Psychoanalytic knowledge was elaborated over the course of many years of clinical work with a whole series of collaborators. Freud sometimes waited ten years before publishing his observations, which, like the theories based on them, were always debated within the circle.

The minutes show why Freud referred to psychoanalysis as “an eminently social affair.” They are an important presentation of an experimental group led by Freud and also help re-create the general intellectual and social climate of Vienna before the First World War.

ERNST FEDERN

See also: Berggasse 19, Wien IX; Rank (Rosenfeld), Otto; Wiener psychoanalytische Vereinigung.

#### Source Citation

Nunberg, Hermann, and Federn, Ernst (Eds.). (1962–1975). *Minutes of the Vienna Psychoanalytic Society* (Vols. 1–4). New York: International Universities Press; (1976–1981). *Die Protokolle der Wiener Psychoanalytischen Vereinigung* (Vols. 1–4). Frankfurt-am-Mein: S. Fischer.

---

## MIRROR STAGE

The mirror stage, occurs when an infant, beginning at six months, discovers its own reflection in a mirror. The baby then turns toward the adult who is holding it and entreats that adult to confirm with his or her expression what it perceives in the mirror, namely the image of a mastery not yet achieved.

It was an observation of Henri Wallon's (1931) in the context of his work on the development of the child's conception of its “own body” that inspired the adoption of the term *mirror stage* and its elaboration by Lacan in particular. Confronted by its own image in a mirror, a six-month-old human will grow excited, fascinated, whereas a chimpanzee of the same age will lose interest as soon as it realizes that the reflection is illusory.

Lacan gave special importance to this moment where the Other confirms that the mirror image is one's own, for at this moment, the infant supposedly

becomes conscious of its body as a totality even before successfully integrating the motor functions and achieving real mastery of that body.

The concept of the mirror stage was Lacan's first formal contribution to psychoanalytic theory, presented at the Fourteenth International Psychoanalytic Congress in Marienbad in 1936. The text of his presentation was not published at the time, but he revisited the issue in a paper published in 1949.

Calling it a "stage" stressed the important place this moment was assigned in mental development. When Lacan said that it occurred between six and eighteen months, this was one of the very rare occasions when he referred to developmental chronology. That said, he also said that the mirror "serves as a prototype that reveals other relations between the subject and his image as the latter is the ego's" (1954).

Between 1936 and 1962, Lacan's concept of the mirror stage underwent a significant reorientation. Early on, Lacan was influenced by Gestalt psychology, and what interested him, as it did a number of ethologists, was the power of the image itself as a finished form, pregnant with meaning, capable of sustaining the baby's identity. Basically, he wanted to trace the effects of the imaginary on the formation of the ego and the body, and the relationship with the counterpart.

When Lacan introduced the concept of the "Other," however, the mirror stage came to indicate how the founding role of the Other's gaze works to form the subject's mental apparatus. Thenceforward the very possibility of the mirror stage presupposed a symbolic operation. Were such operations lacking, the mirror stage would not occur, as happens with the autistic child, in whom there is no relationship in the Imaginary either to a body image or to any kind of counterpart. Beginning with his seminar on the transference (1991 [1960–61]), Lacan took the mirror as a metaphor for the Other's gaze.

Winnicott (1967) extended the Lacanian notion of the mirror stage by emphasizing the part played by the face, and especially the gaze of the mother, as a mirror for the child.

MARIE-CHRISTINE LAZNIK

*See also:* Body image; Ego; Ego ideal/ideal ego; Ethology and psychoanalysis; Identification; Identificatory project; Imaginary identification/symbolic identification; Imaginary, the

(Lacan); Infant development; Infantile psychosis; L and R schemas; Narcissism; Optical schema; Self consciousness; Self image; Self representation; Visual.

### **Bibliography**

- Lacan, Jacques (2002). The mirror stage as formative of the function of the I. In *Écrits: A selection* (Bruce Fink, Trans.). New York: W. W. Norton. (Original work published 1949)
- . (1978). *Le Séminaire-Livre II, Le Moi dans la théorie de Freud et dans la technique de la psychanalyse* (1954–55). Paris: Seuil.
- . (1991 [1960–61]). *Le Transfert* (Jacques-Alain Miller, Ed.). Paris: Seuil.
- Laznik, Marie-Christine. (1993). Pour une théorie lacanienne des pulsions. *Discours psychanalytique*, 10.
- Wallon, Henri (1931, Nov–Dec.). Comment se développe chez l'enfant la notion du corps propre. *Journal de Psychologie*. 705–748.
- Winnicott, D. W. (1967). Mirror-Role of Mother and Family in Child Development. In Peter Lomas, (Ed.), *The predicament of the family: A psycho-analytical symposium*. London: Hogarth and Institute of Psycho-Analysis. (Reprinted in D. W. Winnicott, *Playing and Reality*. London: Tavistock, 1971)

### **Further Reading**

- Muller, John. (1985). Lacan's mirror stage. *Psychoanalytical Inquiry*, 5, 233–252.

---

## **MIRROR TRANSFERENCE**

Mirror transference is the remobilization of the grandiose self. Its expression is: "I am perfect and I need you in order to confirm it." When it is very archaic, mirror transference can easily result in feelings of boredom, tension, and impatience in the analyst, whose otherness is not recognized. Counter-transference is thus a sign of it.

The notion, which first appeared in Heinz Kohut's work in "The Psychoanalytic Treatment of Narcissistic Personality Disorders" (1968), was further elaborated in his *Analysis of the Self* (1971). Mirror transference can take three forms, depending on the degree of regression and the nature of the point of fixation. Fusion transference is the most archaic form and refers to a primary identity relationship in which the Other is completely part of the self. It shows itself when the analyst is taken to be omnipotent and tyrannical and is

experienced as an extension of the self. In twinship or alter ego transference, the other is experienced as being like the self. Lastly, in mirror transference properly speaking, the analyst is experienced as a function in service of the patient's needs. If the patient feels recognized, he experiences a sense of well-being linked to the restoration of his narcissism.

Mirror transference can be primary, the reaction to a broken idealizing transference, or secondary to one of these. In *The Restoration of the Self* (1977), Kohut distinguished it from alter ego transference.

Some authors have refused to consider this transference as being a result of the evolution of narcissism; they have seen it as a defense.

AGNÈS OPPENHEIMER

See also: Alter ego; Grandiose self; *Self, The*.

### **Bibliography**

Kohut, Heinz. (1978) The psychoanalytic treatment of narcissistic personality disorders. In *The search for the self* (Vol. 1, 477–509). New York: International Universities press. (Original work published 1968)

———. (1971). *The analysis of the self*. New York: International Universities Press.

———. (1977). *The restoration of the self*. New York: International Universities Press.

### **Further Reading**

Shengold, Leonard. (1974). The metaphor of the mirror. *Journal of the American Psychoanalytic Association*, 22, 97–115.

## **MITSCHERLICH, ALEXANDER (1908–1982)**

The German physician and psychoanalyst Alexander Mitscherlich was born in Munich on September 20, 1908, and died in Frankfurt on June 26, 1982.

He grew up in Hof, a district in northern Bavaria, the only child of Harbord Mitscherlich, an industrialist, and his wife, Clara. As a youth, Alexander was raised under his father's severe and authoritarian discipline, common in Germany at the time. Graduating from high school in 1928, he first studied history, art history, and philosophy in Munich and Prague. After failing to obtain his doctorate, he went to work in a Berlin bookstore. He developed left-wing political contacts with writer Ernst Jünger and the "National Bolshevik"

Ernst Niekish. (National Bolsheviks favored Germany's rapprochement with the Soviet Union against the rest of Europe.) In 1932, he entered medical school.

Opposed to National Socialism, Mitscherlich was arrested by the Gestapo in 1937 and spent eight months in prison awaiting trial. Afterwards, he was able to continue his medical studies in Heidelberg under physician and philosopher Viktor von Weizsäcker, and successfully defended his doctoral thesis in 1941. Until the end of the war, he worked mainly in the area of psychosomatic medicine at the Ludolf Krehl Clinic in Heidelberg.

Thanks to his clear opposition to the Nazis, Mitscherlich was among a minority of German physicians whom the victorious Allies considered politically trustworthy. As a consequence, he briefly served as minister in the post-war government. He also enjoyed a measure of moral authority among psychoanalysts, many of them Jewish, who, after the rise of National Socialism, had fled to England and the United States. The esteem in which he was held by colleagues abroad, including Anna Freud, proved a great advantage for psychoanalysis in Germany.

Beginning in the 1950s, Mitscherlich succeeded in bringing representatives of the psychoanalytic community to Germany, including Franz Alexander, René A. Spitz, William G. Niederland, Peter Blos, Willi Hoffer, Jeanne Lampl-de Groot, Piet Kuiper, Michael Balint, John Klauber, Paula Heimann, Fritz Morgenthaler, and Paul Parin. He was able to create new credibility for German psychoanalysis, which since the Nazi era was widely thought to be politically retrograde and scientifically discredited. It was principally due to Mitscherlich's prestige that the German Psychoanalytic Association (Deutsche Psychoanalytische Vereinigung), founded in 1950, was recognized by the International Psychoanalytic Association (IPA); he was one of the organization's directors from its inception. Mitscherlich himself had a training analysis with Paula Heimann in London.

Mitscherlich's relationships with German medicine remained problematic, however. In 1947 he published *Doctors of Infamy: The Story of the Nazi Medical Crimes*, written in collaboration with Fred Mielke; it was the fruit of his work as head of the German Medical Commission, which reported to the American Military Tribunal. Mitscherlich effectively transgressed an institutional taboo by reporting on experiments that German physicians conducted on concentration

camp prisoners in a unique document that finally won attention in Germany when it was republished in 1948 under the title *Medizin ohne Menschlichkeit* (Medicine without humanity). Mitscherlich also founded, with Hans Kunz and Felix Schottlaender in 1948, the review *Psyche*, which as of 2005 remains the most important psychoanalytic publication in Germany. As director of the series “Literatur der Psychoanalyse” Mitscherlich helped to raise professional standards of psychoanalysis in Germany to a par with those in other countries.

The high point of Mitscherlich’s institutional work was his helping to found, in Frankfurt in 1960, the Sigmund Freud Institute, where physicians, non-physicians, psychoanalysts, and social scientists could conduct interdisciplinary research on individual and social issues related to psychological disorders. He remained the institute’s director until 1976, and from 1973 to 1976 was on the faculty of philosophy at Johann Wolfgang Goethe University in Frankfurt. As an author, Mitscherlich’s reputation and influence extended well beyond psychoanalytic and philosophical circles. His psychosociological works include *Society without the Father: A Contribution to Social Psychology*, published in 1963 and translated into English six years later. His *Die Unwirtlichkeit unserer Städte* (The inhospitality of the modern city) appeared in 1965. In 1967 he and his wife, Margarete, published *The Inability to Mourn: Principles of Collective Behavior*; translated into several languages, the theme of this controversial work was the failure of Germans to acknowledge the crimes committed in the name of National Socialism.

Mitscherlich was one of the rare scholars and writers—not just in Germany but around the world—who was constantly taking a stance on social and political issues. Philosopher Jürgen Habermas called him “the people’s pedagogue.” To the extent that psychoanalysis was able to revive and ultimately to thrive in post–World War II Germany, is due in great measure to Mitscherlich.

HANS-MARTIN LOHMANN

See also: Germany; Marxism and Psychoanalysis; *Psyche. Zeitschrift für Psychoanalyse und ihre Anwendungen*; Sigmund Freud Institute; *Studienausgabe*; Switzerland (German-speaking).

### Bibliography

- Lohmann, Hans-Martin. *Alexander Mitscherlich mit Selbstzeugnissen und bilddokumenten*. Reinbek: Rowohlt, 1987.
- Mitscherlich, Alexander. (1965). *Die Unwirtlichkeit unserer Städte*. Frankfurt am Main: Anstiftung zum Unfrieden.
- . (1980). *Ein Leben für die Psychoanalyse. Anerkennung zu meiner Zeit*. Frankfurt: Suhrkamp.
- . (1983). *Gesammelte Schriften*. Frankfurt: Suhrkamp, 1983.
- . (1992). *Society without the father: A contribution to social psychology*. New York: Harper. (Original work published 1963)
- Mitscherlich, Alexander, and Mielke, Fred. (1949). *Doctors of infamy: The story of the Nazi medical crimes*. New York: H. Schuman.
- Mitscherlich, Alexander, and Mitscherlich, Margarete. (1975). *The inability to mourn: Principles of collective behavior*. New York: Grove Press.

---

## MNEMIC SYMBOL

The idea of the *mnemic symbol* (*Erinnerungssymbol*) occurs in Freud’s early writings as the equivalent of the notion of the hysterical symptom. A mnemic symbol appears as a hysterical thought with an unaccounted for intense affect, or it manifests itself through compulsion, for example, a hysterical attack in which the patient’s movements represent a seduction scene. The term *mnemic symbol* appears prominently in “A Project for a Scientific Psychology” (1950c [1895]) and *Studies on Hysteria* (1895d), but also in “The Neuro-psychoses of Defence” (1894a) and “The Aetiology of Hysteria” (1896c). In “The Aetiology of Hysteria,” Freud reiterated the explanation given by Josef Breuer in *Studies on Hysteria* (1895d): “The symptoms of hysteria (apart from the stigmata) are determined by certain experiences of the patient’s which have operated in a traumatic fashion and which are being reproduced in his psychical life in the form of mnemic symbols” (pp. 192–193).

The mnemic symbol, a psychic stigma resulting from a traumatic event, is a *mnemic trace*—although not all mnemic traces necessarily correspond to a seduction and a trauma—that displaces the affect associated with the trauma onto an isolated adjacent representation in such a way that the person does not understand the intense cathexis of this representation.



The mnemic symbol is characteristic of a hysterical symptom, but no doubt is also characteristic of all symbols. This notion belongs to the first theory of the neuroses, the theory that trauma causes hysteria, from before 1900, and it is not often encountered in Freud's later writings. A mnemic symbol results from a displacement, as Freud explained in "A Project for a Scientific Psychology": "B stands in a particular relation to A. For there has been an occurrence which consisted of B + A. A was an incidental circumstance; B was appropriate for producing the lasting effect. The reproduction of this event in memory has now taken a form of such a kind that it is as though A had stepped into B's place. A has become a substitute, a *symbol* for B" (p. 349). Condensation and metaphor are also at work here. When A is substituted for B, there is total amnesia of B. B is repressed but remains "a mnemic image like any other; it is not extinguished" (p. 351); that is, it remains as an unconscious memory trace. This explains hysterical compulsion. In hysterical repression, "A is compulsive" (p. 350), and "instead of B, A always becomes conscious—that is, is cathected. Thus it is symbol-formation of this stable kind which is the function that goes beyond normal defence" (p. 352).

The mnemic symbol not only repeats what was experienced at the time of the trauma; it also reinforces it. Affect and libidinal excitation are more intense in the symptom than in the event it commemorates, according to Freud in "The Aetiology of Hysteria." This sheds light on the paradox, recounted in "A Project for a Scientific Psychology," of Emma's childhood seduction, whose attendant affects she did not feel until puberty. The mnemic trace of this traumatic seduction must indeed have been registered when it occurred in childhood, but this trace was only intensified through deferred action, when it was transformed into a mnemic symbol. Emma's fear of entering shops and her conviction that her symptoms came from an episode during puberty where she felt seduced by a young shop assistant were in effect the mnemic symbol, A, of the repressed childhood scene actually at issue, B. The mnemic symbol is the clothing through which Emma was sexually molested as a child. In the episode from her adolescence, Emma thinks that people are making fun of her because her clothes are ridiculous, while she also feels attracted to the young shop assistant. In this case, the mnemic symbol almost takes on the value of a fetish.

The notion of the mnemic symbol, encompassing the notions of mnemic trace, hysterical symptom, and

symbol, may seem overly general, but its definition limits its usage to a very specific field of psychopathology.

FRANÇOIS RICHARD

*See also:* Amnesia; Conversion; Forgetting; Memory; Phylogenesis; Physical pain/psychic pain; Screen memory.

### **Bibliography**

- Freud, Sigmund. (1894a). The neuro-psychoses of defence. *SE*, 3: 41–61.
- . (1896c). The aetiology of hysteria. *SE*, 3: 186–221.
- . (1900a). The interpretation of dreams. *SE*, 4: 1–338; 5: 339–625.
- . (1950c [1895]). A project for a scientific psychology. *SE*, 1: 281–387.
- Freud, Sigmund, and Breuer, Josef. (1895d). Studies on hysteria. *SE*, 2: 48–106.

---

## **MNEMIC TRACE/MEMORY TRACE**

The mnemic trace, the notion of unconscious memory that is essential in Freudian theory, results from the inscription upon the psychic apparatus of a perception that is strong enough to cross the barrier of the protective shield. This perception is totally unconscious, whereas the memory of it is conscious. Sigmund Freud envisaged the psychic apparatus as a system of multiple and complex facilitations of mnemic traces. The mnemic trace, usually sensory, can also be the trace of a thought, especially when it is verbal.

Used throughout Freud's works, this notion appeared in his first theories of the neuroses before 1900, mostly in the "Project for a Scientific Psychology" (1950c [1895]); it was then reformulated in *The Interpretation of Dreams* (1900).

The mnemic trace, a metapsychological construct, originated in neurophysiology. In "Project for a Scientific Psychology," Freud saw in it both the complex reality of "facilitations" in the neurons, which present-day neurobiology would call "neural networks," but also a differential system of inscription of perceptual impressions. The postulate of incompatibility between, on the one hand, consciousness and perception, and, on the other hand, the unconscious and the lasting quality of mnemic traces expressed in 1895 and reiterated in 1900, remained intact throughout the developments of his later work.

In a letter to Wilhelm Fliess dated December 6, 1896, Freud posited that memory consists of multiple strata corresponding to different points in time, and that these are always being rearranged because they are constantly being transformed into different “signs”: In the mnemonic trace, the sensory perception becomes a sign of perception. The German *Erinnerungspur* literally means “trace of a memory.” In Freud’s text the same linguistic root is used for two notions that are contradictory in other languages: the “mnemonic trace,” which is unconscious, and a memory (*Erinnerung*), which is conscious. The semantic slippage between the two terms in Freud’s work reflects the fact that he elaborated the notion of the mnemonic trace based on his theory of seduction and trauma in hysteria, in which the trace of the trauma is conceived as being a more or less forgotten and more or less unconscious memory, resulting in the paradox of an “unconscious memory.”

Freud discovered the existence of the mnemonic trace based on the insistent character of the deformation produced by the trauma—that is, the persistent intensity of the symptom, which he envisioned as a state of charge in the neurons that would evacuate a quantity, producing what he described in *The Interpretation of Dreams* (1900) as “permanent modifications” (p. 538) in the nervous tissues. Mnemonic traces tend to “re-find” their perceptual and conscious origins in a hallucinatory mode. The mnemonic trace is the trace par excellence of the object of desire associated with the scheme of action leading to the satisfaction of the instinct. Essentially a visual trace—although the mnemonic trace can be olfactory, tactile, or verbal—it is sometimes called a “mnemonic image.” In hysteria and in the neuroses more generally, the imprint of mnemonic images and obsessive memories is linked to the pregnancy of the affects. The mnemonic trace corresponds to the impression produced by a perception, not to the perception as such: It is a representation of an absent object, accompanied by affects. In the unconscious, the instinct hallucinatorily cathects the mnemonic trace of this absent object, which can be theorized as an “internal object.”

In 1895 Freud underscored the question of the coincidence between the unconscious representation and the external object of perception, to the extent that the ability to evaluate their identity or their difference defines the ego as a stable agency situated at the boundary between inside and outside. In “Project for a Scientific Psychology” he explained how the ego

inhibits the hallucinatory mode of internal representations and provides the means by which “traces of thought-processes are distinguished from those of reality” (p. 335). His arguments in this essay presume, beyond the difference between mnemonic trace and perception, a difference between traces mediated by thought, which exerts a secondary influence on them, and mnemonic traces strictly speaking, which come from perception.

It is by means of language that traces originating in thought become mnemonic traces, because language is registered at the level of the senses: that is, through hearing speech or reading something written. Verbal mnemonic traces are posited as having the power to bring into consciousness all the other mnemonic traces that they name. But the secondary processes can never totally inhibit the tendency toward immediate discharge in the coalescence between representation and perception, as Freud concluded in “Project for a Scientific Psychology.”

This conception was further elaborated in 1900 in *The Interpretation of Dreams*, where the dream-work is envisioned as the metabolization of a combination of memories, unconscious mnemonic traces, instinctual representatives, and complex thoughts. In chapter 7 Freud proposed a comparison between the mental apparatus and a compound microscope or camera, and wrote: “On that basis, psychical locality will correspond to a point inside the apparatus at which one of the preliminary stages of an image comes into being” (p. 536). He stressed the different types of mnemonic traces, based on, but also beyond, the assumptions that there may be several traces corresponding to a single perception, and that memory traces are grouped according to resemblance or simultaneity. Here, the notion of mnemonic trace is inseparable from that of the unconscious wish seeking identity between representation and perception. Mnemonic traces are “paths which can always be traversed . . . indestructible” (p. 577); when a memory trace “is touched, it springs into life again and shows itself cathected with excitation” (p. 578). The mnemonic trace is thus endowed with the capacity to radiate outward that is characteristic of desire.

In “A Note upon the ‘Mystic Writing Pad’” (1925a), the dominance of the mnemonic trace over consciousness—of which it is ostensibly the necessary prior stage—is attributed to consciousness being switched on and off in alternation within perception, openings

and closings of the psychic apparatus at the interface between the *Pcs.*-*Cs.* and *Ucs.* The sense of the passage of time is posited as being the effect of these openings and closings; the screen between inside and outside, a veil that covers unconscious memory, the protective shield, is above all a receptive surface for impressions destined to become mnemonic traces.

Alongside this metapsychological conception, Freud's work also reflects a historian's approach, with the mnemonic trace attesting to the historical reality of a psyche that develops based on the past. In the case of Emma (reported in "Project for a Scientific Psychology"), the phobic young woman believed that her symptom had originated in an episode during her adolescence in which she had felt seduced by a young man; Freud interpreted this as a screen and displacement of a childhood episode in which she had been sexually molested by an adult. According to Freud, it had to be the case, even if Emma believed she had felt nothing during the childhood incident, and even if the disturbance and the affect of a seduction were only apparent in deferred form during the episode in her adolescence, that at the time of the childhood incident a tension had been established and inscribed as a mnemonic trace that could later be reactivated at the time of her sexual maturation at puberty. The mnemonic trace of the childhood trauma repeated a deformation, a lasting modification, in Emma. Here the trace took a different form, an associative linking as much as a quantitative libidinal charge. It sought in external reality forms that were equivalent to what the early impression aroused, both to expunge its unpleasurable character and to replicate the exciting aspect of seduction.

As early as 1895 in Freud's work, the notion of what will come to be called *repetition compulsion* is based on the idea that the unconscious mnemonic trace is far more evident in repetition—and therefore in what would later be theorized as the transference—than in memories of past events. In a memory there is always a discrepancy between the perception as it was at the time and the current representation of it, whereas in repetition, through "refindings" of situations and substitute objects, the mnemonic trace remains extremely close to the mode of hallucinatory wish fulfillment. In *Studies on Hysteria* (1895d) and "The Aetiology of Hysteria" (1896c), Freud brought out the notion of the mnemonic trace based on the phenomenon of the "excessively intense idea" in the hysteric—that is, as close as possible to the state of hallucinatory wish fulfillment without actually falling into it.

The postulate of an incompatibility between perception and consciousness, on the one hand, and the mnemonic trace, on the other, in some respects comes out of an ontological dualism. Freud held that mnemonic traces are indestructible, but what happens in the case of severe traumas or in certain psychotic states? Are we to take literally Freud's hypothesis, advanced in *Moses and Monotheism: Three Essays* (1939a), of a hereditary phylogenetic transmission of transgenerational mnemonic traces? The notion of the mnemonic trace raises epistemological questions. The paradox of deferred action in the case of Emma's seduction defines the mnemonic trace as both the mirror of an elementary reality and a hypercomplex construction, midway between a materialist ontology and a formalism within a perspective of constant transformation. In the "Project for a Scientific Psychology" Freud compared the charge of the mnemonic trace to the notion of the "moving quantity" from quantum physics, bringing together traditional materialism and a more modern point of view on self-organization and complexity.

Similarities (correspondences) exist between the Freudian notion of the mnemonic trace and some contemporary research in neurobiology and the cognitive sciences, even though the psychoanalytic approach distinguishes itself radically from the latter with its specification of the psychic dimension of a subject governed by the pleasure/unpleasure principle in object relations. The mnemonic trace is not a cognitive representation of the external world; it results from a singular historical construction in which representations are stabilized into thoughts, but also into fantasies and affects. However, the question of the degree of coincidence between mnemonic trace and object of perception, which Freud emphasized, in some respects falls within the purview of the "mentalism" characteristic of cognitive psychology—against a background of Darwinism, because for Freud the search for identity between mnemonic trace and object of perception is what makes possible efficacious action adapted to the environment.

The fiction of the "Mystic Writing Pad" is as much a neurobiological model of memory as it is a metaphor of the mind. There are mnemonic traces that come out of internal psychical productions, rather than from perceptions: The question of the coincidence between mnemonic trace and object of perception must be included in a conception in which it is the subject who constructs his or her "psychology" in a unitary way. As

if to protect himself from any form of spiritualism, Freud wrote in chapter 7 of *The Interpretation of Dreams* that consciousness is “only . . . a sense organ for the perception of psychical quantities” (p. 615)—in other words, that it is constituted only of mnemonic traces of a particular kind. He linked psychology and metapsychology when he used *Erinnerung* for “memory” and *Erinnerungsspur* for “mnemonic trace,” in a conception where it is the conscious ego that remembers the impression (*Eindruck*) of lived experience (*Erlebnis*), but it is unconscious mnemonic traces, independently of consciousness, that contain memory. Alongside *Erinnerungsspur*, the notion of *Gedächtnisspur*, or “trace memory,” is found in Freud’s work.

FRANÇOIS RICHARD

See also: Amnesia; Forgetting; Memory; Remembering; Reminiscence.

### **Bibliography**

Freud, Sigmund. (1896c). The aetiology of hysteria. *SE*, 3: 186–221.

———. (1900a). The interpretation of dreams. *SE*, 4–5: 1–625.

———. (1925a [1924]). A note upon the “Mystic writing pad.” *SE*, 19: 225–32.

———. (1950c [1895]). Project for a scientific psychology. *SE*, 1: 281–387.

Freud, Sigmund, and Breuer, Josef. (1895d). Studies on hysteria. *SE*, 2: 48–106.

## **MODERN CONFLICT THEORY**

The body of psychoanalytic theory about the mind and its functioning has the sobriquet *modern conflict theory* for two reasons. First, they indicate its relation to Freud’s so-called structural theory and his so-called topographic theory, both of which attribute psychoneurotic symptom formation to conflict among or between mental systems or structures. In the case of the earlier, topographic theory the systems or structures are called Unconscious, Preconscious, and Conscious. They are abbreviated as Ucs., Pcs., and Cs. In the case of the later, structural theory, they are called id, ego, and superego. The later theory was an extension and modification of the earlier one. Modern conflict theory is an extension and modification of the

later, so-called structural theory. Second, these words distinguish it from the many other psychoanalytic theories of psychopathology, such as Kleinian theory, Bionian theory, relational theory, subjectivist theory, and so on.

The brain—in particular, the forebrain—is the organ of the mind. Mental functioning is one aspect of cerebral functioning. The functional capacity of the brain changes dramatically during the course of the first several years after birth; with respect to its functioning, the brain is a different organ at birth from what it is later on. By the age of three to four years, on average, the brain is capable of acquiring language and of having thoughts that require language to frame them. Among the thoughts that begin to be identifiable at that time are pleasure-seeking wishes of a sexual and aggressive nature. Children yearn for the attention of other persons, particularly their parents (and parent substitutes) and for the stimulating pleasure of physical contact with them. They are jealous of any rival. They intensely resent any evidence of infidelity, lack of interest, or neglect on the part of the persons they yearn for. They desire revenge, whether against a successful rival, the faithless loved one, or both. Being ignorant, they are curious about what adult sexual partners do to each other and with each other and which to do the same themselves. Being relatively small, weak, ignorant, and unintelligent, they feel inferior and humiliated and, in turn, miserable, desperate, and enraged at feeling so. They intensely desire to be grown-up, sexual men and women who are as clever, wise, and sexually successful as the adults around them seem to them to be. In brief, as Freud pointed out, with respect to his psychological side, a child’s sexual life is in full flower by the time a child is four or five years old, long before it reaches puberty and the beginning of physical sexual maturity.

However, young children ages three to six years are not independent creatures. They are dependent on their caregivers—usually parents—not only physically, but emotionally as well. Parental love, physical contact, approval, admiration, protection, and all that go with them are of the utmost importance as sources of pleasure before, during, and after that time of life. Contrariwise, anything that—in a child’s mind—forfeits or threatens to forfeit parental love and approval, anything that a child believes will turn one or both parents against it, or has already done so, becomes a source of intense unpleasure. High on the list of such sources of

intense unpleasure are a child's own sexual and aggressive wishes, being that many of these are directed toward his parents, against his parents, or both. In other words, the sexual and aggressive wishes that were briefly outlined are longed for and shunned at the same time, a situation labeled as one of mental or psychic conflict.

In general, the mind functions so as to achieve pleasure in thought and action and to avoid unpleasure. In a situation of mental conflict, an individual's thoughts and actions are such as to achieve the maximum of pleasure with a minimum of unpleasure. Such thoughts and actions are labeled compromise formations. Every child, by the very nature of things, finds itself wishing for things that are intensely pleasurable in fact or fantasy and that are also associated with intense unpleasure. Its sexual and aggressive wishes become associated with intensely unpleasurable ideas of disapproval, rejection, abandonment, retribution, and punishment by its parents. That association, that concatenation of pleasure and unpleasure which is the essence of mental conflict, is an inevitable feature of the mental life of every child.

The compromise formations resulting from conflicts over the sexual and aggressive wishes characteristic of ages three to six years can persist into later childhood and into adult life and give rise to psychoneurotic symptoms and neurotic character traits, as Freud discovered as early as 1985. What modern conflict theory adds is that they always persist into adult life, that they are ubiquitous in mental life from the time they first appear. Every thought and every action is a compromise formation that is the result, however disguised and distorted, of conflicts over childhood sexual and aggressive wishes. Such compromise formations are not occasional and abnormal. They are ubiquitous. The difference between "normal" and "pathological" in mental life is not the presence or absence of conflict and compromise formation. The difference is a quantitative, not a qualitative, one. If a compromise formation allows for adequate pleasure from the satisfaction of sexual and aggressive wishes of childhood origin, if it does not involve too much unpleasure in the form of anxiety and depressive affect, if its defensive aspect does not result in too much inhibition of function and too much by way of self-punitive and self-destructive trends, it deserves to be called normal. If the reverse is the case, it is properly labeled pathological.

The calamities, real and fantasied, that give rise to unpleasure can be categorized, as Freud did, into abandonment or object loss, loss of love, and genital injury. The last name is usually referred to, inexactly, as castration. Common to all is, usually, the idea that the child's parents did or will cause them. The nature of the unpleasure can be classified as anxiety or depressive affect. The former, if the thought is that the calamity will happen in the near or distant future, and the latter if the thought is that the calamity has already happened, that it is a fact of life.

Changing to the structural theory from the topographic theory substantially altered psychoanalytic practice by introducing the concept that when an analyst is engaged in analyzing a pathological compromise formation, the analysis of the defensive aspect of the compromise formation is an important part of the analytic work, more specifically, that defenses are to be analyzed, not dealt with in some other way. The change to modern conflict theory from the structural theory makes explicit the idea that every thought and action is potential grist for the analytic mill, rather than just the ones judged to be pathological.

Both the topographic and the structural theory include the conclusion that the mind is best understood as composed of separable symptoms, agencies or structures, each of which is defined according to its functions. As this conclusion appears in the structural theory, the ego is the part of the mind that is attached to and deals with external reality while the id is equally attached to pleasure-seeking sexual and aggressive wishes. Among analysts who accept modern conflict theory as valid there are some who accept the validity of the idea that the mind is composed of separable, functionally different agencies, and some who consider that idea is invalid and should be discarded.

CHARLES BRENNER

### **Bibliography**

- Brenner, Charles. (1982). *The mind in conflict*. Madison, CT: International Universities Press.
- . (2002). Conflict, compromise formation, and structural theory. *Psychoanalytic Quarterly*, 71, 397–417.
- Freud, Anna. (1936). *The ego and the mechanisms of defence*. Madison, CT: International Universities Press.

Freud, Sigmund. (1933). New introductory lectures on psychoanalysis. *SE*, 22: 1–182.

## MODESTY

Modesty is a feeling or a behavior that is motivated by shame, in that it essentially bears upon the sexualized body, the genital organs, the anal zone, or any part of the body that, culturally or individually, is endowed with an erotic investment. In a secondary sense, it is a mode of being that limits all motor or linguistic expression of subjectivity.

In the German language, and thus in Sigmund Freud's writings, it is not possible to distinguish that which is motivated by modesty from that which is motivated by shame, whereas in French, English, and some other languages, two different concepts exist, with modesty in a sense constituting the positive aspect of shame, when the feeling of guilt is transformed into adherence to a socially sanctioned ideal.

The issue of modesty comes up several times in Freud's work, as distinct from the issue of shame. First, it appears as an aspect of the transference and the counter-transference, from the earliest analyses described in "Studies in Hysteria" (1895d). Indeed, "confidence" is why psychoanalysis "invariably leads to the disclosure of the most intimate and secret psychical events" (p. 265), and the lifting of verbal modesty, sometimes accompanied by the gesture of touching the forehead, is the paramount condition for the patient's unreserved speech that is required by the fundamental rule. Second, the origin of modesty is associated with the anal stage, which cannot be reduced to its instinctual localization but instead, as Françoise Dolto underscored, involves, as a whole, motivity and the ethic of the relation to self, others, and the external world. It is in this sense that modesty generates a whole series of instinct-avoidance behaviors, through obsessional-type rituals. Third, it is doubly associated with the phallus and genitality: On the one hand, it lends consistency to the veil of the phallus inasmuch as it is not reducible to the genital organs and is only given up in the experience of symbolic castration; on the other, it valorizes, by keeping it from being seen, genitality and sexual difference, essentially on the feminine side. For both sexes, the hysterical logic of "hiding/showing" is present here.

It is essentially with regard to children, and then adolescents, that the notion of modesty has been examined by psychoanalysts and can be dissociated from shame. In children modesty is not pathological except in its excessive, hysterical, or obsessional forms, which are associated with severe shyness or an inhibition that affects several registers. Otherwise, it corresponds to the child's way of managing the superego and its ego ideals, limiting polymorphous and ordinary perversion. Dolto clearly showed how parents' failure to respect the rules of family life, in the form of slipping into voyeuristic or exhibitionistic behaviors, is by contrast conducive to perversion.

Apart from the issue of the difference in metapsychological and psychogenetic status between shame and modesty, a question raised by the notion of modesty is that of how the anal instinct, the phallic signifier, and genitality are articulated together, whereas orality is governed by a different moral code; this is aptly shown in Luis Buñuel's film *The Phantom of Liberty* (1974), where the characters gather in a circle to defecate together and hide in the lavatory ("au petit coin") to eat.

One can wonder whether the force of modesty is not directly linked, individually or culturally, to the importance of infantile sexual theories about the anus, which might persist and become more pronounced, not only for obsessional personalities, in the access to genitality.

JEAN-JACQUES RASSIAL

*See also:* Anality; Anal stage; Exhibitionism; Latency period; Libidinal development; Shame; Voyeurism.

### Bibliography

Dolto, Françoise. (1985). L'Institution soignante. Cahiers de l'IPC 1985, n° 1, pp. 33-71. Institut des Psychologues Cliniciens. Colloque du 23 novembre 1984.

Freud, Sigmund, and Breuer, Josef. (1895d). Studies on hysteria. *SE*, 2.

## MOM, JORGE MARIO (1922–1997)

Jorge Mario Mom, an Argentinean psychiatrist and psychoanalyst, was born in Cañada de Gómez in the province of Santa Fe in 1922 and died in Buenos Aires in 1997.

Having left his native province with his brothers, Jorge Mom studied medicine in the university of Córdoba. He married María Teresa Muñoz whose father, a farmer and owner of a textile factory, was a veritable patron for the Argentine Psychoanalytic Association (APA).

As a training analyst and president of the APA, he made a name for himself among the second and third generation of Argentinean psychoanalysts. He was a great expert on the works of Freud and Melanie Klein and for many years he expounded on the history of Freudian ideas with a personal vision that left an indelible impression on his students.

In his approach to psychopathology Mom took a keen interest in the concept of anxiety, to which he devoted a large number of theoretical and technical studies. When Willy and Madeleine Baranger arrived in Argentina, Mom established bonds of friendship and exchange with them, which translated into work being presented at various congresses and which constituted an important milestone for the Argentinean school. Prominent among these papers are “Proceso y no proceso en el trabajo analítico” (1982; “Process and Non-Process in Analytical Work,” 1983) and “The Infantile Psychic Trauma from Us to Freud: Pure Trauma, Retroactivity and Reconstruction” (1988). Mom’s primordial goal was to always have an increasingly better understanding of anxiety, anxiety as an alarm signal, and phobias, in Freudian terms, although he was far from disdaining Melanie Klein’s contributions (1956, 1957, 1960). He disseminated his psychoanalytic thinking enthusiastically: He traveled around the country giving lectures and conferences and offering to act as a supervisor. His most important written work is the collection of fifteen studies around the concept of anxiety, as evidenced by his presentation at the thirty-second International Congress of the International Psychoanalytic Association in Helsinki in 1981: *Angustia y falta de angustia en las fobias* (Anxiety and lack of anxiety in phobias).

Jorge Mom was a likeable man, noble, sensitive, and typically Argentine, gifted with a very characteristic sense of humor that enabled him to get out of embarrassing situations.

GILDA SABSAY FOKS

See also: Argentina.

### Bibliography

Baranger, Madeleine, Baranger, Willy, and Mom, Jorge M. (1982). Proceso y no proceso en el trabajo analítico. *Revista de psicoanálisis de la Asociación psicoanalítica argentina*, 39 (4), 527–549; (1983). Process and non-process in analytic work. *International Journal of Psycho-Analysis*, 64, 1–15.

Mom, Jorge M. (1956). Algunas consideraciones sobre el concepto de distancia en las fobias. *Revista de psicoanálisis de la Asociación psicoanalítica argentina*, 13 (4), 430–435.

———. (1957). Algunas consideraciones sobre la interpretación en las fobias. *Revista de psicoanálisis de la Asociación psicoanalítica argentina*, 14 (1–2), 63–71.

———. (1960). Aspectos teóricos y técnicos en las fobias et en las modalidades fóbicas. *Revista de psicoanálisis de la Asociación psicoanalítica argentina*, 17 (2), 190–218.

———. (1962). Consideraciones sobre le concepto de fobia en relación con algunos aspectos de la obra de Melanie Klein. *Revista de psicoanálisis de la Asociación psicoanalítica argentina*, 19, (1–2), 26–33.

---

## MONEY AND PSYCHOANALYTIC TREATMENT

The role of money in the analytic setting is an essential aspect of the arrangements that institute treatment and underpin it as it proceeds. Freud realized early on that subjective attitudes toward money are sure to create difficulties, for they inevitably are affected by outside reality, that is to say social and economic factors, and affect psychic reality, especially in its sexual dimension. Payment, as customarily required in the contract between analyst and patient, is a necessary if not always sufficient condition—the needed symbolic mediation—that frees the analysand from the danger of the analyst’s repeating the kind of abuse to which the analysand has already been subjected in life. It is a mechanism, in other words, that saves the patient, in the transference, from acting out and paying in pounds of flesh and with the coin of suffering. It is also a means of protecting the analytic process from an excess of unanalyzable resistances. The analyst is thus helped in interpreting the transference. And, last but not least, the analyst’s material needs are taken into account.

In two technical papers, “Recommendations to Physicians Practicing Psycho-Analysis” (1912e) and “On Beginning the Treatment” (1913c), Freud addressed the function of payment in the dynamics of therapy and its implications for the transference and counter-transference.

In “On Transformations of Instinct as Exemplified in Anal Erotism” (1916–1917e), Freud discussed the metapsychological ramifications of money in the analytic situation and the equivalence, for the unconscious, of the concept of excrement (and its derivative notions of money and gifts) with the concepts of the infant and the penis. Finally, in 1918, with the publication of *From the History of an Infantile Neurosis* (1918b [1914]), the “Wolf Man” provided the opportunity for considering a variation in the framework of analysis that took the form of money collected to support the patient. In the same year, at the International Psychoanalytic Congress in Budapest, Freud drew attention to the neurotic suffering of segments of the population who for economic reasons were unable to benefit from psychoanalysis, and for the first time he broached the idea of an institute where analysis would be free.

Under the direction of Karl Abraham, the Berlin Psychoanalytic Polyclinic began its activities in 1920. Ernst Simmel, in his report to the Berlin Psychoanalytic Institute in 1930, emphasized the role of the new social institution of “health insurance” in assuming financial responsibility for treatment. From the 1980s this question became the subject of intense debate, though one rarely discussed in the literature, to judge by the scarcity of work on it (Dupeu; Frécourt; Levy; Viderman). Meanwhile, a growing number of analytic practices make use of third-party payment systems (such as health insurance) within a private or institutional context. Thus, there is considerable risk that such systems will strengthen the medical approach to psychoanalysis already strongly developed in many countries.

GHYSLAIN LEVY

*See also:* Anality; Anal-sadistic stage; Eroticism, anal; Feces; Gift; “Notes upon a Case of Obsessional Neurosis” (Rat Man); Pankejeff, Sergei; Symbolism; Viderman, Serge.

### **Bibliography**

Deutschen Psychoanalytischen Gesellschaft (Ed.). (1930). *Zehn Jahre Berliner psychoanalytisches Institut*. Vienna: Internationaler Psychoanalytischer Verlag.

Dupeu, Jean-Marc. (1986, July). L'analyse conventionnée, un analyseur pour la question du paiement en psychanalyse? *Psychanalyses*, 20, 35–49.

Frécourt, Jean. (1988, July). Le psychanalyste est payé. *Psychanalyses*, 28, 3–16.

Freud, Sigmund. (1912e). Recommendations to physicians practicing psycho-analysis. *SE*, 12: 109–120.

———. (1913c). On beginning the treatment. *SE*, 12: 121–144.

———. (1916–1917e). On transformations of instinct as exemplified in anal erotism. *SE*, 17: 125–133.

———. (1918b [1914]). From the history of an infantile neurosis. *SE*, 17: 1–122.

Levy, Ghyslain. (1986, July). Un patient est remboursé, ou Variations sur le thème du paiement et de ses diverses alternatives dans la situation analytique. *Psychanalyses*, 20, 21–23.

Viderman, Serge. (1992). *De l'argent en psychanalyse et au-delà*. Paris: Presses Universitaires de France.

---

## **MONEY-KYRLE, ROGER EARLE (1898–1980)**

Roger Money-Kyrle, a British psychoanalyst and member of the British Psycho-Analytical Society, was born on January 31, 1898, in Hertfordshire and died on July 29, 1980, in London. He was educated at Eton and fought in the First World War and was wounded in France. After the war he went to Cambridge to study mathematics and physics but graduated with a degree in philosophy. In 1919 he started an analysis with Ernest Jones, married, and then spent four years in Vienna to earn a PhD under Moritz Schlick, but also to be analyzed by Freud. Back in London, he decided to study anthropology and earned another PhD, under J. C. Flugel at London University. His thesis was published in 1930 with the title *The Meaning of Sacrifice*.

Money-Kyrle became an associate member of the British Psycho-Analytical Society in 1928, a full member in 1945, and a training analyst in 1949. At the beginning of his psychoanalytic career, he did not take an active part in the scientific life of the society. In the 1930s he began a training analysis with Melanie Klein. Immediately after the Second World War, he spent six months in Germany as part of the German Personnel Research Branch, which sought to find people who had not been involved with the Nazi regime and who could help build up a new administrative and political life in Germany.

His contributions to psychoanalysis can be divided into two parts: works written during the 1930s under the influence of his classical analysis with Freud and later works written under the influence of Klein. From the late 1940s to the 1960s he also commented



on and developed the ideas of Wilfred R. Bion, Hanna Segal, and others.

Money-Kyrle used his broad cultural background in all his work, where philosophy and particularly the British empirical tradition blended with the neopositivistic approach to philosophy of the Viennese school of Moritz Schlick. These interests played an important part in his work, as did his interest in anthropology and the social sciences in general.

Particularly important is his research on the psychoanalytic interpretation of the causes of war: "A Psychological Analysis of the Causes Of War" (1978b) and "The Development of War" (1937). In these papers he foresaw the danger of the Nazi regime and its propaganda, leading to the Second World War. Under the influence of Klein, he became increasingly interested in problems related to the psychoanalytic interpretation of ethics and politics. One result of this interest was *Psychoanalysis and Politics* (1951). Later Money-Kyrle also became interested in clinical issues and problems related to the theory of psychic development. He discussed the problem of inborn misconceptions of the primal scene (adults engaged in sex) and the early Oedipal complex as described by Klein (Money-Kyrle, 1961, 1978). His views have influenced many aspects of neo-Kleinian interpretations of the Oedipus complex.

RICCARDO STEINER

*See also:* Great Britain; Politics and psychoanalysis; Projective identification.

### **Bibliography**

- Meltzer, Donald. (1994). Does Money-Kyrle's concept of misconception have any unique descriptive power? In *Sincerity and other works* (pp. 495–513). London: Karnak Books. (Originally published 1982.)
- Money-Kyrle, Roger E. (1930). *The meaning of sacrifice*. London: L. & V. Woolf and the Institute of Psycho-Analysis.
- . (1937). The development of war. *British Journal of Medical Psychology*, 17, 219–236.
- . (1951). *Psychoanalysis and politics: A contribution to the psychology of politics and morals*. London: G. Duckworth.
- . (1961). *Man's picture of his world*. New York: International Universities Press.

———. (1978a). *The collected papers of Roger Money-Kyrle*. Perthshire, UK: Clunie Press.

———. (1978b). A psychological analysis of the causes of war. In *The collected papers of Roger Money-Kyrle*. Perthshire, UK: Clunie Press. (Originally published 1934)

Steiner, John. (1993). *Psychic retreats*. London: Routledge.

---

## **MONISM**

Introduced into philosophy by Christian Wolff (1679–1754), the notion of *monism* refers to ontologies maintaining that all things lead back to mind or to matter. More generally, monism describes a system in which the totality of things is reducible to a single type of entity, be it substantial, logical, physical, or moral. Variations in usage and the competing expression "philosophy of the One" mean that the term should be used judiciously. People speak of the monisms of Parmenides (515 BCE), Georg Wilhelm Friedrich Hegel (1770–1831), Ernst Haeckel (1834–1919), and Wilhelm Ostwald (1853–1932); of the monism of psychophysical parallelism; and even of the monism of the bridge relation that characterizes dualism.

Freud, who deliberately kept away from philosophy, never used the noun *monism* and seldom used the adjective *monist*. Yet his dualistic theory of the instincts implicitly challenges the idea of instinctual monism. Freud's treatment of this issue began with his early notion of narcissism in "Psycho-Analytic Notes on an Autobiographical Account of a Case of Paranoia (*Dementia Paranoides*)" (1911c [1910]) and culminated in his positing the life and death instincts in *Beyond the Pleasure Principle* (1920g). General discussion of these issues included polemics between Alfred Adler and Carl Gustav Jung, and numerous authors have addressed the topic after 1920. According to Freud, instinctual dualism underlies psychic conflicts and forms the foundation for the psychic structures that result from them.

Narcissism, and thus the libido's cathexis of the ego (the locus of the instincts of self-preservation, according to the first topography) threatened to lead to an instinctual monism and left Freud stymied: "These are problems which we are still quite helpless and incompetent to solve" (p. 74), he wrote in "Psycho-Analytic Notes on an Autobiographical Case of Paranoia (*Dementia Paranoides*)." Moreover, Freud introduced major, complex, irreducible constructs, such as the ego and narcissism, within a theory whose objects he had

been at pains to reduce, in the manner of traditional science. This development posed unprecedented epistemological problems for trying to understand these theoretical entities and brought with it another threat, structural monism. The opposition between object-libido and ego-libido and the idea that the instincts exert continual and constant pressure explained the dynamics of the newly described agencies of the psyche (Freud, 1915c). Freud described additional forms—primary and secondary narcissism, ideal ego and ego ideal—but maintained, as he wrote in “On Narcissism,” that “a unity comparable to the ego cannot exist in the individual from the start; the ego has to be developed . . . , so there must be something added to auto-erotism—a new psychical action—in order to bring about narcissism” (p. 77). Freud spent three years developing the theory presented in “On Narcissism: An Introduction” (1914c). Freud thus reduced the threat of monism by positing of the life and death instincts (1920g) and developing the second topography, set forth in *The Ego and the Id* (1923b).

Freud’s delayed introduction of narcissism and the ego was in part responsible for Adler’s and Jung’s monist dissents. Later, Jacques Lacan’s theories on the signifier (the phallus) would suggest another form of monism, a correlate of his static structuralism.

MICHÈLE PORTE

*See also:* Destrudo; Dualism; Id; Object, change of/choice of; Oedipus complex; Psychosomatic limit/boundary.

### **Bibliography**

- Freud, Sigmund. (1911c [1910]). Psycho-analytic notes on an autobiographical account of a case of paranoia (*dementia paranoides*). *SE*, 12: 1–82.
- . (1914c). On narcissism: An introduction. *SE*, 14: 67–102.
- . (1915c). Instincts and their vicissitudes. *SE*, 14: 109–140.
- . (1920g). Beyond the pleasure principle. *SE*, 18: 1–64.
- . (1923b). The ego and the id. *SE*, 19: 1–66.

### **MONTREAL PSYCHOANALYTICAL SOCIETY.**

*See* Société psychanalytique de Montréal

## **MORAL MASOCHISM**

Moral masochism is seeking unpleasure without being aware of the masochistic sexual satisfaction thus obtained because of unconscious feelings of guilt.

Freud used the term *moral* in *The Ego and the Id* (1923b), where he linked negative therapeutic reactions to a “what may be called a moral factor” (p. 49), an unconscious sense of guilt and its satisfaction by means of punishment and suffering.

In “The Economic Problem of Masochism” (1924c), Freud described moral masochism as the third form of masochism, alongside feminine masochism and erotogenic masochism. In moral masochism the connection to an external object comes undone: “The suffering itself is what matters; whether it is decreed by someone who is loved or by someone who is indifferent is of no importance. It may even be caused by impersonal powers or circumstances; the true masochist always turns his cheek whenever he has a chance of receiving a blow” (p. 165).

Unconscious guilt feelings are thus assuaged. This is at once one of the greatest benefits of neurotic suffering and the source of negative reactions to therapy. Freud made the valuable observation that the notion of a need for punishment applies only to patients whose sense of guilt remains unconscious. The ego’s masochism in fact stems from the cruel superego, which, at its formation, assumed the mantle of the introjected parents. “The dark power of Destiny” (p. 168) is the final figure in this series of authorities that begins with the parents, and it remains their unconscious representative. Whereas self-punishment by the cruel superego is consciously perceived, this is not the case with masochism of the ego.

This shift from self-punishment by the sadistic superego to masochism of the ego is fraught with destructive consequences. It ruins moral consciousness, which is now used to obtain internal, essentially oedipal satisfaction. Indeed, the subject’s relationship to the parents is resexualized by an eroticization of the ego’s relationship to the superego. The analysis of moral masochism thus reveals a feminine masochism and, in the final analysis, an erotogenic masochism. The subject must suffer endless self-punishment, because all punishment is subverted to masochistic gratification. In this context Freud, in “Dostoevsky and Parricide” (1928b [1927]), evoked certain Russian

character types. Arising from instinctual fusion and libidinal satisfaction, moral masochism comes from a death drive that has not been diverted outward, and for this reason is dangerous.

It is worth noting that in its incestuous internal regression, which is all the more effective because any impersonal life circumstance can mask its nature, masochism of the ego in fact denies all authority and subverts the impersonal nature of the superego (which Francis Pasche as a prerequisite of its effective functioning). This circumstance makes ego masochism into an instrument of transgression even more apt to conceal the incestuous relation to internal objects. The self-destructive aspect of ego masochism also comes from a relative de-objectification of external objects in their otherness. The moral masochist loses the strong sadomasochistic pregenital bond with the object that is found in sexual perversion.

DENYS RIBAS

*See also:* Masochism.

### **Bibliography**

- Freud, Sigmund. (1923b). The ego and the id. *SE*, 19: 1–66.
- . (1924c). The economic problem of masochism. *SE*, 19: 155–170.
- . (1928b [1927]). Dostoevsky and parricide. *SE*, 21: 173–196.
- Pasche, Francis. Du surmoi ambivalent au surmoi impersonnel. *Bulletin Méditerranéen de la Société Psychanalytique de Paris*, 1, 7–19.

### **Further Reading**

- Spiegel, Leo. (1978). Moral masochism. *Psychoanalytic Quarterly*, 47, 209–236.
- Markson, Elliott. (1993). Depression and moral masochism. *International Journal of Psychoanalysis*, 74, 931–940.

## **MORENO, JACOB LEVY (1889–1974)**

Jacob Levy Moreno, a Romanian physician and the creator of the psychodrama technique and sociometry, was born in Bucharest in 1889 and died in Beacon, New York in the United States in 1974.

Opinions vary concerning his exact date of birth: 1889 or 1892? It would seem that when he arrived in the United States he declared himself to be three

years younger than he actually was. He was the son of Moreno Levy, who came from an old Sephardic Jewish family of Bulgarian origin (though Turkish by nationality), and his mother was Romanian. Failing business (his father sold funerary objects) forced the family to move repeatedly; they lived in Romania, Germany, Austria, and Hungary during his youth.

Moreno settled in Vienna where he began to study medicine and philosophy. He qualified as a physician in 1917 under the psychiatrist Otto Petzel. His double training, combined with his interest in theatre, very quickly led him to take an interest in the possibilities for expression offered by dramatic art and to seek a new therapeutic method using the cathartic efficacy of improvisation. Starting from this base he created an "experimental theatre" in Vienna in the 1920s, inviting the participants to propose and play scenes in which they would play different roles in turn. The purpose of these "role plays" was to sensitize each person to the different aspects of their own personality and those of their partners, to open the way for creative spontaneity and the expression of their emotional capacities.

He emigrated to the United States in 1925 and settled in Beacon, on the banks of the Hudson. While actively continuing his experiments with psychodrama (particularly family psychodrama), Moreno was increasingly drawn to study interpersonal relations and group dynamics. He particularly tried to introduce group therapy into psychiatry and into prisons (Sing Sing, for example). Research in this area formed the basis of sociometry, which he developed in a book entitled *Who Shall Survive?* published in 1934. Sociometric techniques aimed to provide an objective description of the interactions operating within groups, and to theorize about the different aspects of group interaction. Anxious to maintain the originality of his research, Moreno adopted a critical attitude to psychoanalysis, without denying its usefulness.

In 1950 he created the International Committee for Group Psychotherapy in Paris, and organized the first World Conference on Psychodrama there in 1964. This opened the way for new exchanges between psychodramatists, psychoanalysts, and specialists in corporal medicine. After that his methods met with increasing success in the United States and in Europe. Child psychoanalysts in France remodeled his psychodrama technique and transformed it into a veritable analytical treatment, which progressively spread to adults also.

NADINE AMAR

See also: Analytic psychodrama; Family therapy; Group psychotherapy.

### Bibliography

Marineau, René. (1989). *J.-L. Moreno et la Troisième Révolution psychanalytique*. Paris: Métailié.

Moreno, Jacob Levy. (1934). *Who shall survive? Foundations of sociometry, group psychotherapy and sociodrama*. New York: Beacon House.

———. (1947). *The theater of spontaneity: An introduction to psychodrama*. New York: Beacon House.

———. (1959). *Gruppenpsychotherapie und Psychodrama, Einleitung in die Theorie und Praxis*. Stuttgart: G. Thieme.

———. (1966). *The international handbook of group psychotherapy*. New York: Philosophical Library.

## MORGENSTERN-KABATSCHNIK, SOPHIE (1875–1940)

Sophie Morgenstern-Kabatschnik, a Polish psychiatrist and psychoanalyst, was born on April 1, 1875. She committed suicide in Paris on June 16, 1940.

Coming from a Polish Jewish family, she began to study medicine in Zurich in 1906. In 1915 she was working as an assistant physician in the Burghölzli asylum under Eugen Bleuler. She moved to France sometime in 1924. It was around this time that she began her analysis with Eugénie Sokolnicka, who is considered to have introduced psychoanalysis to France. Beginning in 1925, Morgenstern became a volunteer worker in the auxiliary clinic for infantile neuropsychiatry directed by Georges Heuyer, who always spoke highly of her even after he dissociated himself from the psychoanalytic movement. The date of her marriage to Abraham Morgenstern is unknown, as is the date of his death. Her only daughter, Laure, unanimously recognized as being extremely intelligent and having a brilliant future, died during an operation, probably in 1937.

Morgenstern killed herself when German troops entered Paris in 1940. All who knew her at the time stressed the unfathomable suffering caused by her daughter's death; few made any mention of her status as a Jewish émigré.

Between 1927 and 1939 Morgenstern published fifteen articles and one book. Her work was entirely based on an in-depth reading of Sigmund Freud. In the

conflict between Anna Freud and Melanie Klein, she firmly allied herself with Anna Freud's position. She believed that child neurosis shared the same structure and the same origins as adult neurosis, but the greater malleability of the infantile superego facilitated the resolution of conflicts. She stressed the importance of caution in the formulation of interpretations and considered, unlike Melanie Klein, that they should not anticipate the sexual curiosity of the young patient.

With the 1927 publication of "Un cas de mutisme psychogène" (A case of psychogenic mutism), she described her technique for treating children—drawing—which was to remain the primary focus of her research throughout her practice. She also used games, modeling, and, of course, dreams and free association with older children.

Morgenstern was without doubt one of the pioneering figures in child psychoanalysis in France, particularly with regard to the use of drawing in treatment. Her contributions to the *Revue française de psychanalyse* and *L'Évolution psychiatrique* reflects the fact that her peers recognized the importance of her work. Françoise Dolto was her most illustrious student. All who take an interest in her work must ask why she has slipped into unjustified oblivion. Her book, *Psychanalyse infantile Symbolisme et valeur clinique des créations imaginatives chez l'enfant* (Child psychoanalysis, symbolism, and the clinical value of children's imaginative creations; 1937), like her articles "A Case of Psychogenic Mutism" (1927) and "Quelques aperçus sur l'expression du sentiment de culpabilité dans les rêves des enfants" (Some insights into the expression of guilt in children's dreams; 1933) deserve to be reread in the light of recent research inspired by her original work in child psychoanalysis.

FRÉDÉRIQUE JACQUEMAIN

See also: France; Heuyer, Georges; Child analysis

### Bibliography

Morgenstern, Sophie. (1927). Un cas de mutisme psychogène. *Revue française de psychanalyse*, 1 (3), 492–504.

———. (1930). La psychanalyse infantile et son rôle dans l'hygiène mentale. *Revue française de psychanalyse*, 4 (1), 136–162.

———. (1933). Quelques aperçus sur l'expression du sentiment de culpabilité dans les rêves des enfants. *Revue française de psychanalyse*, 6 (2), 155–174.

———. (1937). *Psychanalyse infantile (symbolisme et valeur clinique des créations imaginatives chez l'enfant)*. Paris: Denoël.

———. (1939). Le symbolisme et la valeur psychanalytique des dessins infantiles, *Revue française de psychanalyse*, 11 (1), 39–48.

## MORGENTHALER, FRITZ (1919–1984)

Fritz Morgenthaler, a Swiss physician specializing in neurology and a member of the Swiss Psychoanalytic Society, was born at Oberhofen on July 19, 1919 and died on October 26, 1984, while visiting Addis Ababa.

The son of a famous painter (Ernst Morgenthaler) and doll designer Sacha Morgenthaler-von Sinner, he was also a painter and a professional juggler. He was educated in Zurich and Paris, studied medicine in Zurich and then worked as a physician in war-torn Bosnia for one year. This was the beginning of his friendship, then scientific collaboration and, beginning in 1952, joint practice with Paul Parin and Goldy Parin-Matthèy. In 1947 he commenced his analysis with Rudolf Brun. Between 1954 and 1971, Morgenthaler accompanied the Parins on six voyages of ethno-psychoanalytic research in West Africa (Parin, et al., 1963, 1971).

Most of Morgenthaler's remarkable influence was due to his charm and the intellectual sparkle of his personality as a lecturer, seminar director, and supervisor. Starting from a case history or a dream, he had an exceptional gift for communicating the psychic functioning of the patient, the unconscious emotional relations between the analyst and the analysand, and for discovering new and unexpected aspects therein. His original approach to Freud's dream in 1986: *Ein Traum als Beweismittel* (An evidential dream) is a good example of this: although he may not have opened up new theoretical pathways, he used Freudian concepts pertinently and effectively.

His often playfully dialectic mode of thinking earned him divided opinions with regard to the scientific value of his work. When his admirers praised him for making great progress and outstripping Freud in therapeutic technique (1978), in the theory of sexuality (1984), and in analyzing dreams (1988), more detached observers ranked him in classic psychoanalytic thinking somewhere between Freud and Kohut. In his later work he did, however, try to work politico-social (Marxist-inspired) concepts into the theory of psychic functioning, but without much success: the "sexual" as an

indeterminate motion, without orientation of the primary process (1988, p. 106–107), is considered as an "emotionality" (p. 107) that alone enables us to "appear alive," (p. 107) and this "sexual" runs up against the "dictatorship of sexuality" (1988, p. 110), which is "established by the instinctual and ego developments by means of the events in the secondary process in order to absorb the motion of the primary process, guide it into certain controllable channels, and restrict it by means of conditions" (p. 110).

KASPAR WEBER

See also: Switzerland (German-speaking).

### Bibliography

- Freud, Sigmund. (1913a). An evidential dream. *SE*, 12: 267–277.
- Morgenthaler, Fritz. (1978). *Technik zur Dialektik der Psychoanalytischen Praxis*.
- . (1986). *Der Traum, Fragmente zur Theorie und Technik der Traumdeutung* (P. Parin, Ed.). Frankfurt am Main: Campus.
- . (1988). *Homosexuality, heterosexuality, perversion*. (Andreas Aebi, Trans.). Hillsdale, NJ: Analytic Press.
- Parin, Paul, Morgenthaler, Fritz, and Parin-Matthèy, Goldy. (1963). *Die Weissen denken zuviel. Psychoanalytische Untersuchungen bei den Dogon in Westafrika*. Zürich: Atlantis.
- . (1971). *Fürchte Deinen Nächsten wie Dich Selbst: Psychoanalyse und Gesellschaft am Modell der Agni in Westafrika*. Frankfurt am Main: Suhrkamp.

## MORICHAU-BEAUCHANT, PIERRE ERNEST RENÉ (1873–1952)

Pierre Morichau-Beauchant, a French physician and professor at the Poitiers school of medicine, was born in Vivonne, France on November 1, 1873, and died in Poitiers in 1952. He was the first Frenchman to join the Freudian movement, in 1910.

His father, Joseph Eugène Beauchant, was a notary in Vivonne and his mother, née Berthe Brillouin, the only child of an apothecary in the Vendée. As a result of bad business deals his father moved to Paris. Pierre was a gifted child and had excellent academic results in the Collège Stanislas (winner of the *Concours Général* for French lycées) and later in the medical faculty. He took the Paris internship examination in 1899, being

forced by necessity to also give Latin and Greek lessons. On completing his military service in 1902, he joined *Le Sillon* (The Furrow), a Christian Democratic movement, founded that year and managed by Marc Sangnier (1873–1950).

In 1903, he was appointed assistant commissioner for hospitals and assistant professor in the Poitiers medical school. In 1904, he married Édith Rambaud, a pharmacist's daughter and a pharmacy intern in Paris. They had five children and their three sons also became doctors and professors of medicine. He was mobilized during the First World War, and was made a Knight of the Legion of Honor in 1918. He was appointed professor of clinical medicine in 1919 but kept his private practice and, upon retiring in 1941, he continued as an honorary consulting professor of geriatric medicine in the Dalesmes hospital until 1951.

As a highly cultured man, a good German scholar, and free of prejudice, he read *The Interpretation of Dreams* (1900a), *Three Essays on the Theory of Sexuality* (1905d), and soon began to read the Viennese analytic reviews. He tested the Freudian method and wrote to Freud in 1910, introducing himself as a disciple: "This letter will show you that you also have disciples in France who follow your work with passion." In the same year he wrote the first psychoanalytic article to be published in France: *L'Inconscient et la défense de l'individu* (The unconscious and the individual's defense), published in the social review *L'Effort* (The effort), founded by the writer Jean-Richard Bloch, who put him in charge of the Psychology and Psychiatry section. Two further articles appeared under his name in this review, *La défense de l'espèce dans l'hérédité* (The defense of the species in heredity) and *Le déterminisme héréditaire et la liberté humaine* (Hereditary determinism and human freedom), to be followed by the better known *Le rapport affectif dans la cure des psycho-névroses* (The affective relationship in curing psycho-neuroses), published in 1911 in the *Gazette des hôpitaux* (The hospital gazette).

Freud noted his importance, seeing "Mr Beauchant, the intelligent Frenchman" as "a good sign" and "solid support" for acceptance of his method in France. He sent Angélo Hesnard to him, requesting help and clarification with his thesis. Ernest Jones recognized that he had "a good grasp" of Freud's theories.

In 1912, he was elected a member of the Zurich Psychoanalytic Association and became an occasional

collaborator in the *Zentralblatt für Psychoanalyse* and the *Jahrbuch*. But he played no part in the birth of the French psychoanalytic movement, nor in any of its events. He no doubt moved away from Freud and psychoanalysis on the occasion of the break with Jung. His name does not appear in psychoanalytic literature or correspondence after 1914, when Freud mentioned him in "On the History of the Psycho-Analytic Movement" (1914d).

We are particularly indebted to him for his analytical observations of children, as in *L'instinct sexuel avant la puberté* (The sexual instinct before puberty), one of the first works on the nostalgia of soldiers, work on infectious pathology, and especially gastroenterology in which he discusses the hypothesis of psychic causality and recommends psychotherapeutic treatment.

MICHELLE MOREAU RICAUD

See also: France.

### Bibliography

- Morichau-Beauchant, Pierre. (1910) L'inconscient et la défense de la vie. *L'Effort*, 1.
- . (1911). Le rapport affectif dans la cure des psychonévroses. *Gazette hôpitaux*, 84 (14), 1845–1849.
- . (1912). Homosexualität und paranoia. *Zentralblatt für Psychoanalyse*, 2, 174–176.
- . (1912). Les troubles de l'instinct sexuel chez les épileptiques. *Journal médical français*, 6 (4), 155–161.
- . (1912). L'instinct sexuel avant la puberté. *Journal médical français*, 6 (5), 375–382.

---

**MORITZ-FREUD, MARIA (MITZI).** See Freud, Sigmund (siblings)

---

### MORSELLI, ENRICO (1852–1929)

Enrico Morselli, an Italian psychiatrist, academic, and active promoter of the Italian positivist school of neuropsychiatry, was born in Modena on July 17, 1852, and died in Genoa on February 18, 1929.

A famous clinician and president of the Italian Society for Neurology and Psychiatry, he was director of various psychiatric hospitals and took an interest in many disciplines, ranging from anthropology to philosophy and biology to psychiatry. As an influential personage in Italian cultural circles at the beginning of the twentieth century, this Lombrosian organicist never missed an opportunity to vaunt the superiority of the “Italian Lombroso” over the “Austrian Freud.”

His writings deal with a great variety of subjects: He discussed euthanasia and suicide, pathological psychology and animal psychology, psychiatry, traumatic neuroses, semiotics and anthropology, magnetism, spiritualism, forensic medicine, and blood transfusions.

He is also known as the author of a large two-volume work titled *La Psicanalisi* (Psychoanalysis), published in Milan by Boca in 1926. Reprinted many times and widely promoted in university circles, it would be impossible to underestimate its disastrous influence on psychoanalysis in Italy. An apparently well-documented work, it is a magnificent example of resistance to psychoanalysis, of incomprehension and the impossibility of comprehending. Just after it was published, Sigmund Freud wrote a letter to the author on February 18, 1926, in which he spoke of Morselli’s “important” work while regretting that he could not give his “approval to our young science: what is referred to as psychoanalysis—esteemed colleague—is not psychoanalysis!” (1960a).

Marked by Lombrosian thinking and paternalistic concepts, Morselli criticized all of Freud’s theories from sex to religious questions. Horrified by homosexuality and so-called perversions of any kind, he adopted a moralistic attitude and delighted in the use of exasperating mockery. He repeatedly accused Freud of plagiarism, and tried at length to prove that all the foundations of Freudian research already existed in the work of the Italian positivist school. Freud’s letter in response to *La Psicanalisi* is an interesting example of Freud’s tact and tactical sense; making an effort to speak positively about Morselli’s work, he nevertheless uses this foil to advance the cause of psychoanalysis.

GIANCARLO GRAMAGLIA

*See also:* Italy.

### **Bibliography**

Contri, B. Giacomo. (1994). *Il Pensiero di natura*. Milan: Sipiel.

Freud, Sigmund. (1960a [1873–1939]). *Letters of Sigmund Freud, 1873–1939*. (Ernst L. Freud, Ed.; Tania and James Stern, Trans.). London: Hogarth.

Gramaglia, Giancarlo. (1992). Notes sur la psychanalyse italienne entre les deux guerres, 1915–1945. *Revue internationale d’histoire de la psychanalyse*, 5, 129–142.

Morselli, Enrico Agostino. (1926). *La Psicoanalisi, Studii ed appunti critici*, vol. I: *La Dottrina*, vol. II: *La Practici*. Milan: Fratelli Bocca.

---

## **MOSER-VON SULZER-WART, FANNY LOUISE (1848–1925)**

Fanny Louise Moser, née von Sulzer-Wart, was born in Switzerland on July 29, 1848, and died in Au, near Zürich, on April 2, 1925. She was the patient described in Freud’s *Studies on Hysteria* (1895d) under the pseudonym of Emmy von N. Ola Andersson discovered her identity in 1965 and Henri F. Ellenberger completed her biography in 1977.

She was the thirteenth of fourteen children born to a rich aristocratic family. Reared by a mother who is described as severe and austere, she caused a scandal in her milieu on December 28, 1870, when she married Heinrich Moser, a rich industrialist forty-two years her senior. They had two daughters, Fanny, born on May 27, 1872, and Mentona (named after the town Menton in the south of France) on October 19, 1873.

Following her husband’s sudden death in 1874, his son from a previous marriage contested the will that made Fanny an extremely wealthy widow, and rumors began to spread to the effect that she had poisoned her husband. She demanded an autopsy, which proved to be negative, but the suspicions remained.

From 1875 to 1877 she traveled from one spa town to another but finally settled in a sumptuous residence she acquired near Zürich, where she could lead the sophisticated social life she desired. She is said to have had numerous lovers and her visitor’s book bears witness to the social standing of her guests. It also records visits by Auguste Forel and Eugen Bleuler, among other physicians. Freud figures there on July 18, 1889.

She commenced the cure described in the first case study in *Studies on Hysteria* on the first of May preceding Freud’s visit. The treatment ended in June but Freud visited her in the course of a journey to meet Hippolyte Bernheim in Nancy.

We know that he treated her for another eight weeks in 1890 and saw her again in the spring of 1891. On that occasion he stayed in her residence for a few days because she was having difficulties with her older daughter. He also resumed her treatment briefly. Relations between them did not end on a good note, as evidenced by the slip of paper masking his signature in her visitor's book, the usual sign that someone had fallen from grace in her eyes.

In a note added to her case history in 1924 Freud recounts that some years after that last visit he met a doctor with whom she had behaved as she had with him: docile and easy to hypnotize in the beginning, then irritable and subject to relapses. "It was a genuine instance of the compulsion to repeat." We know that toward the end of her life she fell passionately in love with a younger man who persuaded her to part with some of her fortune. The letter Freud received in about 1920 from her older daughter probably corresponded to this situation. The daughter asked him for a certificate because she wanted to make a legal case against the "cruel despot" who had estranged Moser's two children.

She died on April 2, 1925, and was buried in the Kilchberg cemetery near Zürich.

ALAIN DE MIJOLLA

See also: Emmy von N, case of.

### **Bibliography**

- Anderson, Ola. (1962). *Studies in the prehistory of psychoanalysis*. Stockholm: Svenska Bokförlaget.
- Ellenberger, Henri F. (1977). L'histoire d'Emmy von N. *L'Évolution psychiatrique*, 42 (3/1), 519–540.
- Freud, Sigmund, and Breuer, Josef. (1895d). Studies on hysteria. *SE*, 2: 48–106.

---

## **MOSES AND MONOTHEISM**

Begun in 1934, and rewritten in 1936, Freud's *Moses and Monotheism* appeared in an abridged form in the review *Imago* (the first two essays), and the final version was published in 1939. It also appeared in the *Standard Edition* edited by James Strachey (1964).

Upon first examination the work seems somewhat disordered, and contains repetitions and inconsistencies. The writing appears to reflect the movement of

Freud's thought, his doubts and hesitation, his concern regarding the scientific nature of the information he provides, and his fears concerning the way the text might be received among Viennese Catholics and by the Jewish community.

The work contains three essays of unequal length, "Moses an Egyptian," "If Moses Was an Egyptian," and "Moses, His People, and Monotheistic Religion." The last essay includes prefatory notes written at different times, one in Vienna before Freud's departure for Great Britain, the other in London, which partly contradicts the first. Finally, part two of the third essay is preceded by a "Summary" in which he reevaluates much of the information in the first essays.

*Moses and Monotheism* can be approached in several different ways. First, it is a biography of Moses, the "historical novel" whose scientific nature Freud wanted to establish. Freud claims that Moses was not Jewish but Egyptian and bases this claim on the fact that the name "Moses" was Egyptian, as well as on certain considerations about the family origin of heroes, based on Otto Rank's *Myth of the Birth of the Hero* (1909).

In the second essay Freud tries to understand the reasons that would have led Moses to assume the leadership of the minority people who were to become Jews and impose a new religion upon them. He then comes up with the idea that what would become Mosaic religion originated in the cult of Aton practiced by the pharaoh Amenotep IV. Moses, as a devoted believer, is said to have adopted the new religion as his own. After the revolt that followed the death of the pharaoh, Moses chose exile and the creation of a people upon whom he was able to impose his religious beliefs, together with the (Egyptian) practice of circumcision. These are the people he led out of slavery. The cult of Aton and following Mosaic faith brought to religion, for the first time in history, the monotheistic notion of a unique and universal god. Because of his tyrannical and domineering character, and his desire to impose a monotheistic religion upon all Jews, Moses is said to have been assassinated during a revolt of the Jews against his authority.

Freud meets the criticism that situates the exodus one or two centuries after the reign of Akhenaton by advancing the idea that Moses did not draw his religious beliefs directly from the pharaoh but from priests who had been devotees of the cult of Aton. He



also responds to certain historical conclusions that situated the origin of the Jewish religion in the cult of a volcano god, Yahweh, defeated by a Moses who was of Midian origin, by postulating the fusion of two religions: Aton's religion of truth and justice, which was temporarily repressed by the religion of Yahweh, which was focused more on conquest. While reconstituting the history of the Jewish people, Freud rediscovers the dualist system that was so important to him: the fusion of two Moses in a single character, of two new religions into a single monotheistic religion, of two peoples into a single nation.

Freud's work is thus an explanation of the formation of monotheistic religion on the basis of parricide (that of Moses), the collective repression of this murder, its passage from memory, but also its survival in the unconscious and its reappearance in religious phenomena. This theme is similar to one developed in *Totem and Taboo*: parricide as the origin of civilization and monotheistic religion. According to Freud, this explanation holds for both the Jewish religion, where parricide is not recognized as such but reappears in the feeling of guilt, and Christianity, where guilt (original sin) and parricide are recognized and assumed. Paul of Tarsus (the true founder, for Freud, of the Christian religion) is supposed to have recognized the murder. The expiation of parricide could only be carried out by the sacrifice of an expiatory victim: the son of God himself. The euphoria of being the chosen people in the Jewish religion is replaced in Christian religion by the sentiment of compensatory liberation through the sacrifice of the son. Original sin and atonement through sacrifice are the pillars of the new religion founded by Paul. In Freud's approach, Moses is desecralized, reduced to his human nature (as in "The Moses of Michelangelo," [1914b]), and God is reduced to a strictly human origin arising from projections of the individual unconscious.

Freud's *Moses and Monotheism* represents an application of the data of individual metapsychology to collective psychology. For Freud there is an "analogy" between the collective phenomena upon which religions are based and the process of repression at work in individual development according to the following schema: infantile trauma—defense—latency—onset of neurotic illness and partial return of the repressed. As Marie Moscovici noted, Freud's work on Moses is also a consideration of the status of the father, whose function escapes any sensory appreciation or direct

perception, and who can only be recognized as father through the mental activities of the son who designates him as father. *Moses and Monotheism* is also a reflection on Jewish identity, the character traits on which it is based and which ensure its longevity, the hatred it arouses in anti-Semitism and which Freud explains as the price to be paid for the denial of parricide and the refusal to acknowledge this.

As in all of Freud's work, one possible reading of Moses can refer to the individual history of the founder of psychoanalysis. The book was written immediately before his death. It constitutes what is almost his final text at a time when he feared that psychoanalysis, because of the rise of Nazism and the internal struggles among his own followers, was threatened with extinction. The idea that some might desire the death of the founder of psychoanalysis, just as the Jewish people would have desired the death of Moses, was probably not far removed from his contemplation of parricide.

PIERRE FERRARI

*See also:* Anthropology and psychoanalysis; Collective psychology; Complementary series; Cultural transmission; Ethics; Historical truth; Judaism and psychoanalysis; Mythology and psychoanalysis; Politics and psychoanalysis; Primitive horde; Racism, anti-Semitism, and psychoanalysis; Return of the repressed; Sociology and psychoanalysis, sociopsychology; Visual.

### Source Citation

Freud, Sigmund. (1939a [1934–1938]). *Der Mann Moses und die monotheistische Religion: Drei Abhandlungen*. Amsterdam, Allert De Lange; G.W, XVI, p. 103–246; *Moses and monotheism: Three essays*. *SE*, 23: 7–137.

### Bibliography

- Freud, Sigmund. (1914b). *The Moses of Michelangelo*. *SE*, 13: 209–238.
- Gay, Peter. (1988). *Freud: A life for our time*. London-Melbourne: Dent.
- Jones, Ernest. (1953–1957). *Sigmund Freud: Life and work*. London: Hogarth Press.
- Moscovici, Marie. (1986). Préface. In Sigmund Freud, *L'Homme Moïse et la Religion monothéiste. Trois Essais* (p. 15–53). Paris: Gallimard.
- Rank, Otto. (1952). *The myth of the birth of the hero; a psychological interpretation of mythology* (E. Robbins and Smith Ely Jelliffe, Trans.). New York: R. Brunner. (Original work published 1909)

Yerushalmi, Yosef Hayim. (1991). *Freud's Moses, Judaism terminable and interminable*. New Haven and London: Yale University Press.

### “MOSES OF MICHELANGELO, THE”

“The Moses of Michelangelo” is a short essay on Michelangelo’s masterpiece adorning the tomb of Pope Julius II in the church of San Pietro in Vincoli in Rome. Freud provides a reading of this enigmatic work that has given rise to a number of contradictory interpretations. The essay was first published anonymously in volume 3 of *Imago* in April 1914, then acknowledged by Freud in 1924 during the publication of volume ten of his collected works in German. In 1927 he added an afterword reaffirming his 1914 interpretation.

Freud saw the *Moses* for the first time in 1901. The idea for writing the essay came to him during a trip to Rome with Ferenczi in September 1912. On his return to Vienna he pored over texts about the statue, then had photographs sent to him of the various details. But doubts concerning the accuracy of his interpretation continued to torment him. He returned to Rome in September 1913 and visited the tomb several times. He wrote his essay in a few days at the end of 1913.

Freud’s approach in this essay is unique and radically unlike his work on Leonardo da Vinci and his interpretation of Saint Anne. His reading of the *Moses* is not based on a construction of Michelangelo’s unconscious libidinal past or even on the concepts or theoretical developments arising from psychoanalysis. It makes use of a procedure developed by Ivan Lermolieff, which was used to distinguish original paintings from copies on the basis of details that had been neglected by the copyists.

So, it was the details of the statue that had been neglected or distorted in descriptions, the “rubbish heap, as it were of our observations” (1914b, p. 222), that Freud focused on: the position of the right hand of Moses and the twists of his beard that it holds, the position of the Tablets of the Ten Commandments.

After a minute description of these details, he reconstructs and illustrates, in a series of drawings, the changes in position he assumes they have undergone to clarify their role in the sculpture. The sacrilegious implications of the statue then become obvious—on the verge of rising and allowing his anger to break out, Moses restrains himself to save the Ten Commandments.

The essay has elicited a number of commentaries and articles primarily bearing on Freud’s interpretation of the statue. But the singularities of the text and Freud’s approach (treating the unnoticed details of observations as letters whose displacement reveals their hidden meaning) have supplied analysts with a number of opportunities that remain largely unexplored.

BRIGITTE LEMÉRER

*See also:* Applied psychoanalysis and the interaction of psychoanalysis; Literary and artistic creation; *Moses and Monotheism*; Visual arts and psychoanalysis.

#### Source Citation

Freud, Sigmund. (1914b). Der Moses des Michelangelo. *Imago*, 3, 15–36; *G.W.*, X, 172–201; The Moses of Michelangelo. *SE*, 13: 209–238.

#### Bibliography

Jones, Ernest. (1953). *Sigmund Freud: Life and work*. London: Hogarth Press.

Lemérer, Brigitte. (1997). *Les Deux Moïse de Freud (1914–1939). Freud et Moïse: écritures du père 1*. Ramonville-Saint-Agne: Érès.

Yerushalmi, Yosef Haim. (1991). *Freud's Moses, Judaism terminable and interminable*. New Haven and London: Yale University Press.

### MOTHER GODDESS

The expression *mother goddess* or *maternal divinity* designates a historic or prehistoric female figure that was the object of a cult. The oldest examples are found in Paleolithic Europe; these are the Venuses found in grottoes that served as sanctuaries. The exaggerated breasts and buttocks and the clear demarcation of the pubis relate them to fertility cults. Similar statuettes from different geological periods have been found in other regions.

The beginning of the Neolithic period, with the introduction of agriculture and large-scale breeding, coincided with a multiplication of these fertility symbols, especially in the Middle East. The great goddesses of love, such as Aphrodite and Venus, partially absorbed the functions of the earlier mother goddesses, even though their form evokes female seduction more than maternity.

The concept of maternal divinity was addressed by Sigmund Freud in 1911 in an article on the Diana of the Ephesians (1911f) and in 1913 in an article on patterns on caskets (1913f).

Starting from a work of French archeology, Felix Sartiaux's *Villes mortes d'Asie Mineure*, Freud established a parallel between the cult of Artemis, the great goddess of Ephesus, and the cult of the Virgin Mary, who, according to tradition, is said to have ended her earthly existence at Ephesus alongside the apostle John. The cult of Artemis, often assimilated with Diana, is said to have served as the model for that of Mary as a maternal divinity. Freud reminds us of the extraordinary popularity of this "pagan" goddess, whose worship provided a livelihood for a guild of goldsmiths, who started a riot when a prediction by Saint Paul led to competition. Also, in his article on the patterns on caskets (a theme taken from Shakespeare's *Merchant of Venice*), he notes that Artemis, like all the maternal divinities of Asian peoples, is a goddess of both life and death, of generative and destructive principles.

The theme of maternal divinity does not play a central role in the work of Freud, who was much more interested in male figures like the father of the horde (see *Totem and Taboo* [1912-13a]) or Moses. The same is true of Jacques Lacan who emphasizes the paternal phallus as the primordial signifier, in the same way as the linga ("sign" in Sanskrit) of the god Shiva is the structuring element of Indian religion. Carl Gustav Jung and Jungian psychoanalysts in general have considered these maternal divinities to be of considerable importance, representing an archetype of the universal Great Mother, a figure that is both maternal and sovereign, filled with pity and compassion (1933). The work of Jung's followers has found considerable support in American feminist circles. Archeological digs conducted during the last few decades across the five continents have revealed an abundance of female statuettes, often corresponding to the oldest layers of the civilization being studied. The main problem remains the interpretation of this material given our frequent uncertainty concerning the role of women in prehistoric or protohistoric societies and the state of their knowledge about human reproduction. The omnipresence of these female figures could be associated with ignorance about the fecundating role played by sperm. These mother goddesses, the most recent example of which would be the Virgin Mary, might thus symbolize a kind of parthenogenesis.

ODON VALLET

See also: India; "Theme of the Three Caskets, The"; Totem/totemism.

### Bibliography

- Freud, Sigmund. (1911f). Great is Diana of the Ephesians. *SE*, 12: 342–344.
- . (1912-13a). Totem and Taboo. *SE*, 13: 1-161.
- . (1913f). The theme of the three caskets. *SE*, 12: 291–301.
- Gimbutas, Marija. (1989). *The language of the goddess*. New York: Harper & Row.
- Jung, Carl G. (1938 [1954]). Psychological aspects of the mother archetype. *Coll. works*, Vol. 11. London: Routledge & Kegan Paul.
- Neumann, Erich. (1955). *The Great Mother: An analysis of the archetype*. London: Routledge.

---

**MOTHERING.** See **Maternal care**

---

### MOURNING

The "work of mourning" is a set of mental processes, conscious and unconscious, initiated by the loss of an emotionally and instinctually cathected object. Once this work is complete, the subject is gradually able, within a period of time that cannot be shortened, to separate from the lost object.

Extreme pain, denial of reality, hallucination of the presence of the object, and awareness of the loss of the object are experienced in sequence. Eventually the mental changes occur that allow attachment to new objects to develop.

The notion of the work of mourning was introduced by Freud in "Mourning and Melancholia" (1916–17g [1915]). He seems to have been particularly concerned with death and mourning at the time—the middle of the First World War, when everyone in Europe was dealing with such losses—for these issues are also mentioned in "Thoughts for the Times on War and Death" (1915b) and "On Transience" (1916a [1915]).

Having lost his father in 1896, Freud had himself experienced grief and mourning; his father's death is

mentioned in *The Interpretation of Dreams* (1900a). The long hiatus between that death and Freud's conceptualization of the work of mourning underlines the cardinal role of the passage of time in this context: Freud's own mourning preceded by far the greater part of his written work, a fact that reminds us not to confuse the psychic work of mourning with any kind of intellectual work. Talking, reflecting, or writing about a bereavement does not amount to a work of mourning. Intellectual mastery or the power of discernment are not of much help when it comes to reassembling everything associated with the lost object. Finding words to express the pain, the unimaginable distress caused by the loss, is usually an insurmountable task as much for those who seek to console as for the bereaved. On the other hand, particular words may sometimes indeed evoke the lost object or a recognizable link to that object, but the forms of such speech cannot be predicted or laid down in advance.

"What is painful may none the less be true," wrote Freud in "On Transience" (1916a [1915], p. 305). This remark, made a few months after he composed "Mourning and Melancholia," encapsulates an essential part of his thinking on mourning. Accepting the truth of the object's disappearance involves suffering. The work of mourning is not unlike the work—the "labor"—of childbirth. Any birth takes time, and, like truth, is the outcome of a creative process. The truth of a loss acknowledged is no exception to this rule.

For Freud the pain of mourning was an enigma. What to the ordinary mortal seems obvious and inevitable posed an insoluble problem for the inventor of psychoanalysis. Viewing the cruelest of patent facts as a question to be answered exemplifies the heuristic approach of psychoanalysis, for which the patent is not the true—indeed, it may even hide the truth. Anyone agreeing to accompany the mourner during this depressive process will be obliged to experience it in himself, and for himself.

The main point of "Mourning and Melancholia" is to show how these two states have certain depressive traits in common. In addition to a highly contagious feeling of sadness, the two share three characteristics: loss of interest in the outside world, loss of the capacity to love, and the inhibition of all activity. The suspension of interest in the outside world is indicated by the disappearance, from one day to the next, of all attention directed toward the environment, close or distant. What was of the highest importance yesterday ceases

utterly to exist today. The only other state displaying such a marked narcissistic withdrawal is sleep. In that case, being cut off from the outside world facilitates access to the intimacy of the inner world, of unconscious wishes, by way of another kind of psychic work, namely the dream-work. Could it be that, as in dreams, withdrawal into mourning makes it possible to organize the world not on the basis of external perceptions, but on the basis of a subjectivity turned completely inward? Inasmuch as sleep is a prerequisite of mental recuperation, a chance to start again relying on one's inner resources, it would seem reasonable to conclude that a kind of psychic restoration likewise occurs through mourning, with its deferment of all outside stimuli; that the loss of a cathected object requires a psychic reorganization so absorbing that it means confining all cathexis to the internal world. There are in fact few tasks more engrossing than taking stock of what will never again exist.

This withdrawal of object-libido, and the dismantling of all the bonds that have hitherto united subject and object, is bound to result in the second abovementioned common feature of mourning and melancholia, namely loss of the capacity to love. Exaggerated concentration on oneself prevents any consideration of others and blocks any expression of affection. For the time being, the cathexes available to the ego cannot be directed onto objects. Freud did not confine himself to this economic view, however, in his interpretation of the disappearance of all loving impulses toward objects. He speculated that any potential attachment to another object could imply the lost object's replacement. By taking care not to become attached to a new object, the subject was in effect defending himself against the charge of lethal intentions with respect to the lost one. But to imagine, as a defense, that one might have an impact on the outside world—be the cause, in the event, of the object's disappearance—is itself a way of refusing reality. For the object's finite nature exists in that outside world, irrespective of the subject's wishes; it is, precisely, what is at stake in the subject's relationship with reality.

Meanwhile, cutting oneself off from external reality paradoxically implies the necessity to acknowledge it. The psychic working out of the loss on the plane of subjectivity and object relationships leads to the subject's detachment from other aspects of reality also. From this derives the third corollary of mourning, the inhibition of *all* activity. Inaction and indifference to

outside reality do not arise exclusively, however, from absorption in the work of mourning. Such indifference indeed includes attempts to deny the reality of object-loss by denying all reality. Oscillation between the recognition of reality and its denial accounts for the contradictory and circular tendencies often observed in this context.

The experience of mourning is paradoxical. Overcoming the loss of an object means an exaggerated presence of that object in the psychic activity of the bereaved. The work of mourning may thus be defined as an excessive attention paid to an object in order to come to terms with its definitive demise.

BENJAMIN JACOBI

*See also:* Abandonment; Acting out/acting in; Acute psychoses; Allergic object relationship; Asthma; Ethics; Fatherhood; Internal object; Memory; “Mourning and Melancholia”; Negative, work of the; “On Transience”; State of being in love; Taboo; Time; Work (as a psychoanalytical notion).

### **Bibliography**

- Freud, Sigmund. (1915b). Thoughts for the times on war and death. *SE*, 14: 273–300.
- . (1916a [1915]). On transience. *SE*, 14: 303–307.
- . (1916–17g [1915]). Mourning and melancholia. *SE*, 14: 237–258.

---

## **“MOURNING AND MELANCHOLIA”**

The manuscript of “Mourning and Melancholia” dates from 1915, but the paper was not published until two years later. In this short, rich article, Freud described the essence of melancholia by comparing it to the normal affect of mourning. He distanced himself from the psychiatric perspective he had once adopted in “Draft G” of the Fliess papers (1950a [1895]), while emphasizing that the concept of melancholia had many aspects (especially somatic ones) that he would not examine. Methodologically speaking, here as so often we encounter Freud’s continual effort to clarify the psychopathological by reference to the normal (as for example with dreams, jokes, or parapraxes).

This essay is a direct pendant to Freud’s “On Narcissism: An Introduction” (1914c), a context that helped him characterize melancholic regression (see

Otto Rank, as cited by Freud in relation to the narcissistic basis of object choice.). Freud also made use of the ideas of Karl Abraham (to whom he submitted the first draft of the paper for comment) concerning cannibalistic orality and the ambivalence of the bond that lies at the origin of melancholia. He also developed the concept of identification (“incorporation” for Abraham) and advanced the notion of the work of (normal) mourning (*Trauerarbeit*) on the model of the dream work (binding). The period during which he developed his ideas on mourning, that of the First World War, was particularly significant for Freud.

Freud’s definition of mourning is very broad, comprising, aside from the reaction to the loss of a loved one, reactions to any substituted abstraction (fatherland, freedom, ideal). This conception, which is connected with that of abandonment being sublimated as an abstract idea, is not developed further, but it does introduce sociopolitical perspectives of considerable importance.

Freud stressed an economic definition of mourning (loss of interest in the outside world) and the work of grieving as it acts on the binding of painful memories, an ego activity quite unrelated to the attenuation stemming from the forgetfulness associated with the passage of time. He immediately discusses the similarities with, and above all the differences from, melancholia, which is characterized by an apparently unjustified loss of self-esteem. “In mourning the world has become impoverished and empty, during melancholia, it is the ego itself” (p. 246). However, melancholic self-depreciation is actually directed at the love object itself. For this was the cause of disappointment for the subject, who, instead of withdrawing cathexis, unconsciously identifies with the now-hated object to which he remains ever more firmly attached. This pathological development stems on the one hand from the narcissistic nature of the initial object choice, which by its nature promotes narcissistic regression, and on the other hand from the ambivalence of the choice and the predominance in it of the sadistic impulse, which here assumes masochistic form, while directly tormenting the patient’s entourage. This helps explain suicide as a redirection toward the self of a murderous impulse originally directed at others. Reversion to mania is likewise explained, in economic terms, as a sudden release from the psychic charge maintained by melancholia.

But in melancholia as in mourning, it is essentially the work consisting in finishing with the object (by

degrading it or declaring it dead) that will “strike dead” the dead and release the subject. This theory of melancholia is clinically important in considering the different forms of depression. It has also been confirmed by a number of anthropologists and embodies some of the ideas Freud set forth in *Totem and Taboo* (1912–1913a). The notion of identification was further developed in *Group Psychology and the Analysis of the Ego* (1921c). Thus “Mourning and Melancholia” occupies a central position for both individual and group psychology.

SOPHIE DE MIJOLLA-MELLOR

See also: Abraham, Karl; Depression.

### Source Citation

Freud, Sigmund. (1916–1917g [1915]) “Trauer und Melancholie,” *Intern. Zschr. ärztl. Psychoanal* 4, p. 277–287; *G.W.*, 10, 428–448; Mourning and melancholia. *SE*, 14: 243–258.

### Bibliography

Freud, Sigmund. (1914c). On narcissism: An introduction. *SE*, 14: 67–102.

———. (1950a [1887–1902]). Extracts from the Fliess papers. *SE*, 1: 173–280.

## MOURNING, DREAM OF

The dream of mourning is a “typical” dream in which someone close to the dreamer is dead or in which their death is evoked.

In *The Interpretation of Dreams* (1900a), Freud returned several times to this type of dream, which he included among those “typical dreams” whose form and content are similar for everyone.

He discussed the objection that the painful nature of such dreams seemed to run counter to his main thesis that all dreams are fulfillments of wishes. One had to accept, he said, that despite their sad subject matter these dreams did, in fact, express a secret wish for the death of the person concerned; the dreamer’s brother or sister (rivals to be eliminated), or father or mother (in the oedipal context, often first articulated in such dreams). There is often relatively little affect in these dreams, a fact that astonishes the dreamer when she or he recalls the dream upon awakening. This lack of feeling, explained Freud, was because the dream fulfilled

childhood wishes, a legacy of the time when death was conceived simply as the disappearance of the person in question. Later, in “Fragment of an Analysis of a Case of Hysteria” (1905), he would analyze Dora’s dream of her father’s death in detail.

Freud never perceptibly changed his views on this type of dream; his theory of dreams as the fulfillment of wishes continued to prevail, even after *Beyond the Pleasure Principle* (1920g).

ROGER PERRON

See also: Dream.

### Bibliography

Freud, Sigmund. (1900a). *The Interpretation of Dreams*. *SE*, 4–5: 1–625.

———. (1905e [1901]). Fragment of an Analysis of a Case of Hysteria. *SE*, 7: 1–122.

———. (1920g). *Beyond the Pleasure Principle*. *SE*, 18: 1–64.

### Further Reading

Aberbach, David. (1984). Loss and dreams. *International Review of Psychoanalysis*, 11, 383–398.

## MOUVEMENT LACANIEF FRANÇAIS (FRENCH LACANIAN MOVEMENT)

More than twenty associations emerged from the 1980 dissolution of the École freudienne de Paris (EFP, the Freudian School of Paris) and the demise of La Cause freudienne (The Freudian Cause) in January 1981. A new school, the École de la cause freudienne (The School of the Freudian Cause) was immediately formed as a substitute for them. What follows is a chronological listing of the principle groups.

On the February 1, 1981, Claude Dumézil and André Rondepierre founded the Cartels Constituants (Constituent Cartels), an association that was later weakened by the death of Rondepierre and numerous defections that formed the basis of two other groups.

On March 7, 1981, Jean Clavreul, Solange Faladé, and Charles Melman founded the Centre d’études et de recherches freudiennes (CERF, Center for Freudian Study and Research), which collapsed just a short while later and was the origin of three other groups.

In June 1982, Charles Melman founded the Association freudienne (Freudian Association), which has since become the Association freudienne internationale (AFI, International Freudian Association), the most important of a number of Lacanian associations. This group publishes *Discours psychanalytique*, *Le Journal de la psychanalyse de l'enfant*, *Le Trimestre psychanalytique*, *Le Journal français de psychiatrie*, and since 1999, *La Célibataire*. The AFI, which reintroduced the question of the pass in June 1994, has a large number of members in both Belgium and Argentina.

On June 28, 1982, Maud Mannoni put forth a call for an institution that could ensure the training of young analysts. She subsequently founded the Centre de formation et de recherches psychanalytique (CFRP, the Center for Psychoanalytic Training and Research) with Octave Mannoni and Patrick Guyomard. This group developed rapidly and numbered 550 members at the time of its dissolution in 1995. It also published *Esquisses Psychanalytiques* and an important series on psychoanalysis with the publisher Denoël.

The École lacanienne de psychanalyse (ELP, the Lacanian School of Psychoanalysis) was founded in 1983, by former members of the Constituent Cartels, Jean Allouch, Guy Le Gaufay, Philippe Julien, Erik Porge, and Christian Simatos. This group maintained the ritual of the “pass,” but did not nominate the passer. It is very intellectually active and publishes numerous journals, including *Littoral* (forty-four volumes published) and *L'Unebvue* (twelve issues published as of 1999). The ELP is very active in Latin America and includes many Argentines and Brazilians.

Analyse Freudienne (Freudian Analysis) was founded by Claude Dumézil after the breakup of the Constituent Cartels. It publishes *Analyse freudienne* (seventeen issues in 1999), which became *Analyse freudienne presse* in 2000.

Two numerically important associations arose out of the dissolution of the CFRP. One was L'Espace Analytique (Analytic Space), founded by Maud Mannoni on October 16, 1994; it publishes *Figures de la psychanalyse*. The other was the Société de psychanalyse freudienne (Society for Freudian Psychoanalysis) founded in February 1995 by Patrick Guyomard. This group publishes the *Lettres de la société de psychanalyse freudienne*. Like the CFRP, both of these groups reject the pass and emphasize teaching and the training of analysts. Analysts become members upon the approval of an authorizing jury, which takes into account the

course of the candidates' careers and their analytic practice.

Other important groups include the École freudienne (Freudian School), founded in 1983 by Solange Faladé, the Cercle Freudien (The Freudian Circle), and the Mouvement du coût freudien (Freudian Cost Movement).

On the international level, many Lacanians exist within a flexible organization, Convergence. And the Interassociatif européen de psychanalyse (European Coalition for Psychoanalysis) gathers together many of the organizations listed above as well as several others in France, Denmark, Spain, Italy, and Luxembourg.

Finally there is the Association pour une instance tierce de la psychanalyse (APUI, Association for a Third Era in Psychoanalysis) which was founded by Serge Leclair in January 1990. This group reflects upon the position of psychoanalysis in European culture, holds biannual seminars, elaborates on the place of psychoanalysis and psychoanalysts in society, and opposes state and medical constraints on psychoanalysis.

JACQUES SÉDAT

*See also:* Althusser, Louis; Aubry Weiss, Jenny; Aulagnier-Spairani, Piera, ex-Castoriadis-Aulagnier; Beirnaert, Louis; Belgium; Brazil; Canada; Certeau, Michel de; Dolto-Marette, Françoise; École de la Cause Freudienne; École Expérimental de Bonneuil; École Freudienne de Paris; France; Great Britain; Hesnard, Angélo Louis Marie; Italy; Leclair (Liebschutz), Serge; Mannoni, Dominique-Octave; Mannoni-Van der Spoel, Maude (Magdalena); Merleau-Ponty, Maurice; *Ornicar?*; Pass, the; Peraldi, François; Perrier, François; Portugal; Spain, history of psychoanalysis in; Splits in psychoanalysis; Sweden.

---

## MÜLLER-BRAUNSCHWEIG, CARL (1881–1958)

Carl Müller-Braunschweig, a German psychiatrist, philosopher, psychoanalyst, an founder and president of the German Psychoanalytic Association (DPV), was born in Braunschweig on April 8, 1881, and died in Berlin from arteriosclerosis on October 12, 1958, after a long illness.

His father, Heinrich Müller, owned joinery works in Braunschweig. Müller-Braunschweig studied philosophy

with Jonas Cohn, Heinrich Rickert, Cay von Brockdorff, Paul Menzer, Carl Stumpf, Georg Lasson and, most importantly, Alois Riehl. His studies also included physics, biology, history, and political economy. Beginning in the winter of 1901–1902, he spent time studying in Heidelberg, Freiburg, Braunschweig, and Halle. In 1905 he settled with Riehl in Berlin and concluded his Kantian studies with a PhD in 1909.

After finishing his medical studies, particularly in psychiatry, with Karl Bonhoeffer (1912–1914), he completed his training by undergoing analysis with Karl Abraham, and then Hanns Sachs. He was a member of the Berlin Psychoanalytic Association (BPV) from 1919, in charge of training at the Berlin Psychoanalytic Institute (BPI), and became a member of the Executive Committee of the International Psychoanalytical Association (IPA) in 1925.

After a first marriage to child analyst Dr. Josine Müller, née Ebsen (1884–1930), which ended in divorced in 1925, he married the Jungian analyst Ada Schott (his analysand in training), with whom he had two children (Hans in 1926 and Elke in 1927).

Following the Nazi rise to power in 1933 he was appointed provisional president of the “Aryanized” committee of the German Psychoanalytic Society (DPG). In this capacity he worked as editor, treasurer, training analyst, and president of the candidates’s commission, and broadly concentrated on adapting the institute ideologically to the National Socialist regime.

In 1938 Matthias H. Göring appointed him administrator in charge of the Vienna Psychoanalytic Society, the Berlin polyclinic and psychoanalytic publications, but he failed in this last mission because the National Socialists questioned his loyalty. He was then prohibited from conducting personal and training analysis, as well as from teaching in the Göring Institute, a prohibition he later invoked when claiming to be a “victim” of the Nazis.

On October 16, 1945, he was commissioned to reconstruct the DPG and appointed president of the society. In spite of his Jungian affinities (he had undergone some analysis with the Jungian Gertrud Weller), he found himself viewed as the representative of orthodox psychoanalysis. His intense personal and theoretical disputes with Harald Schultz-Hencke, the medical founder of neoanalysis who had succeeded in winning government recognition for the profession (psychoanalysis and psychotherapies were financed by social security in the Zentralinstitut für psychogene Erkrankungen

[Central Institute for Psychogenic Diseases]), found their epilogue in an official confrontation at the first post-war congress of the IPA, held in Zurich in 1949. This led to the creation of the German Psychoanalytic Association (DPV) on June 10, 1950, which then began to offer classic training in the Berlin Psychoanalytic Institute. Members who had stayed in the DPG were angry with their president for secretly forming a new association. Only the DPV was admitted to the 1951 IPA congress in Amsterdam.

While continuing to practice as an analyst, Müller-Braunschweig taught psychoanalysis at the Berlin Free University. He was particularly interested in the intersection between anthropology and psychoanalysis. From 1920 until the Nazis took power he regularly wrote in the *Internationale Zeitschrift für Psychoanalyse*, in the *Zeitschrift für Sexualwissenschaften*, and in *Imago*. After the war he concentrated essentially on a detailed exegesis of Freud’s work.

REGINE LOCKOT

*See also:* Berliner Psychoanalytisches Institut; Deutsches Institut für Psychologische Forschung und Psychotherapie (“Göring Institute”); Germany; Göring, Matthias Heinrich; International Federation of Psychoanalytic studies; Splits in psychoanalysis.

### **Bibliography**

- Lockot, Regine. (1985). *Erinnern und Durcharbeiten: Zur Geschichte der Psychoanalyse und Psychotherapie im Nationalsozialismus*. Frankfurt am Main: S. Fischer.
- . (1994). *Die Reinigung der Psychoanalyse: Die deutsche psychoanalytische Gesellschaft im Spiegel von Dokumenten und Zeitzeugen (1933–1951)*. Tübingen: Diskord.
- Müller-Braunschweig, Carl. (1933, 22 October). Psychoanalyse und Weltanschauung. *Reichswart*.
- . (1948). *Streifzüge durch die Psychoanalyse (Welche Position vertritt der Psychoanalytiker heute)*. Hamburg: Reinbeck.
- . (1955). Zur Menschlichen Grundhaltung, Psychologie und Technik der Psychoanalytischen Therapie. *Psychologische Beiträge*, 2, 56–69.

---

## **MULTILINGUALISM AND PSYCHOANALYSIS**

Multilingualism is the ability to understand and speak several languages. The general term covers



plurilingualism (learning to speak several languages simultaneously) as well as polyglottism (learning other languages after one acquires one's mother tongue). It can be used as a generic term whenever there is no need to differentiate between the two situations. Its initial appearance in the psychoanalytic vocabulary is difficult to date.

The term was redefined in *The Babel of the Unconscious* (Amati Mehler et al., 1990). Prior to this there was little interest in the analytical significance of multilingualism, which is surprising given that the history of the psychoanalytic movement is itself crisscrossed by the migration and transmutation of languages since Freud's first patients came to see him in Vienna.

For a number of those patients (the "Wolf Man", Miss Lucy, even some analysts, like Princess Marie Bonaparte), German was not their mother tongue. Freud even analyzed some of his English-speaking patients in English, which at the end of his life became the language he used most frequently in his work. So, during the first years of the psychoanalytic movement, it was rare that the analyst and his patient shared a native language.

The multilingualism of the patient, just as the plurilingualism of the analyst, presented difficult questions about the analytic framework and analytic technique, as well as challenges to the conceptual apparatus of psychoanalysis. And although it may not be necessary to attribute a specific form of mental operation to multilingual individuals, the unique pathways multilingualism adds to the flow of the unconscious deserve further study.

Ever since *On Aphasia* (1891b), the question of the transition from one language to another had caught Freud's attention. He noted "the loss, through damage to the speech apparatus, of new languages acquired as super-associations, while the mother tongue is preserved" (p. 87). He observed the differences between word representations and thing representations, which later enabled him to define the factors that made the unconscious different from the preconscious-conscious system (1915e). The relation between word representation and thing representation defines a crucial substrate of the multilingual context.

Assuming that the multilingual speaker enriches the fabric of his preconscious with other word representations, what happens to their links with thing representations? Do both systems always refer to the same

thing representation or does the thing representation also change? Answers differ. Some believe that thing representations remain the same, while others have introduced a deviation that refers to two distinct thing representations. According to the latter hypothesis, thing representations would still be part of the same associative complex, deviating because of a particular cathexis of the thing representation by the affective representative of the drive—most important according to Freud. For Erwin Stengel (1939), a new language establishes a new libidinal relationship with the word and the thing to which it refers.

The second language can come to the aid of a vacillating system of repression, be a sign of splitting or isolation, or even produce new symbolic richness. It is the subject's personal vicissitudes that will determine if the other language is used for resistance or allows for greater intrapsychic plasticity in the act of working-through.

Finally, multilingualism should not obscure the fact that the subject must perform an act of translation in every act of communication with others, as well as between his or her intrapsychic agencies.

JUAN-EDUARDO TESONE

See also: Aphasia; Linguistics and psychoanalysis.

### **Bibliography**

- Amati Mehler, Jacqueline, Argentieri, Simona, Canestri, Jorge. (1993). *The Babel of the unconscious: Mother tongue and foreign tongues in the analytic dimension* (Jill White-law-Cucco, Trans.). Madison, CT: International Universities Press.
- Freud, Sigmund. (1891b [1953]). *On aphasia; a critical study* (E. Stengel, Trans.). New York: International Universities Press.
- Stengel, Erwin. (1939). On learning a new language. *International Journal of Psycho-Analysis*, 20, 471–479.
- Tesone, Juan-Eduardo. (1996). Multi-lingualism, word-presentations, thing-presentations and psychic reality. *International Journal of Psycho-Analysis*, 77, 871–881.
- Urtubey, Luisa de. (1988). Dites tout ce qui vous passe par la tête, tout comme cela vous vient et dans la langue où cela vous vient. *Revue française de psychanalyse*, 52 (2), 463–472.

---

**MURDER OF THE FATHER.** See Parricide

## MURRAY, HENRY A. (1893–1988)

American psychologist and psychoanalyst Henry A. Murray was born in New York City on May 13, 1893, and died in Boston on June 23, 1988. He was one of the most important pioneers who introduced psychoanalysis into American academic psychology.

Originally trained as a physician, he was analyzed by both Carl G. Jung and Franz Alexander, and became one of the founding members of the Boston Psychoanalytic Society. Not only was Murray a leader in the field of personality theory, but Murray (with the help of Christiana Morgan) created the Thematic Apperception Test (TAT). He also took a leading role in making psychological profiles for the American government's Office of Strategic Services during World War II. For years Murray headed the Harvard Psychological Clinic, originally founded by Morton Prince, and he also worked on the writings of Herman Melville for almost half of his long life. Although Murray took a wholly independent path apart from both Freudian and Jungian organizations, his contact with both men has to be considered historically memorable.

Although Murray was self-taught as a psychologist, he felt proud to be in the humanistic tradition of a philosopher like William James. He remains notable for having inspired generations of graduate students. His TAT test was a means of drawing forth from people by means of words and stories important aspects of personality that an individual could or would not volunteer. The TAT test was designed to be both a diagnostic tool and a research tool. His most famous single book, which was the outcome of collaborating with others at his Psychological Clinic, was *Explorations in Personality* (1938). He also co-edited, with the Harvard anthropologist Clyde Kluckhohn, an influential book of readings, *Personality in Nature, Culture, and Society* (1948).

Murray, along with Kluckhohn and the sociological theorist Talcott Parsons, helped create the famous, but short-lived, interdisciplinary Department of Social Relations at Harvard. And he was illustrious enough to have been asked to testify as an expert witness in behalf of Alger Hiss in the second trial that ended in Hiss's being convicted of perjury. (Murray's social standing was so secure, one of his forbearers having been the last Tory governor of Virginia, that J. Edgar Hoover's FBI conducted only the most cursory report on him.) Dean Acheson, secretary of state under President Harry Truman, was a classmate of Murray's

at Groton, and reported in 1970 that Murray had been the "outstanding" member of their class "in the sense of originality of mind, curiosity about everything, sympathetic personality, catholicity of taste, cultural breadth." Murray felt blocked as a writer, not just in connection with his Melville project but in explaining his whole orientation toward human nature. Yet he remains memorable not just for his emphasis on turning from the abnormal to the normal, and from failure to success, but because he fought against dogmatism in psychoanalysis as unscientific, and insisted on distrusting any truth that became a sect.

PAUL ROAZEN

### Bibliography

- Anderson, James W. (1988). Henry A. Murray's early career: A psychobiographical exploration. *Journal of Personality*, 6 (1), 139–71.
- Kluckhohn, Clyde and Murray, Henry A. (eds.). (1948). *Personality in nature, society and culture*. New York: Knopf.
- Murray, Henry A. (1938). *Explorations in personality*. New York: Oxford University Press.
- Roazen, Paul. (2003). Interviews on Freud and Jung with Henry A. Murray in 1965. *Journal of Analytical Psychology*, 48 (1), 1–27.
- Robinson, Forrest. (1992). *Love's story told: A life of Henry A. Murray*. Cambridge, MA: Harvard University Press.

## MUSATTI, CESARE (1897–1989)

Cesare Musatti, an Italian psychoanalyst and psychologist, was born in Dolo (Venice) on September 21, 1897, and died in Milan on March 20, 1989. He was a leading figure for the first generation of Italian psychoanalysts.

He spent his childhood and adolescence in Venice, his family's hometown. His mother was an elementary school teacher and his father, a Jewish idealist and revolutionary, was a socialist deputy.

In 1915 he began to study mathematics in the university of Padua before moving on to the faculty of philosophy. He studied under Vittorio Benussi before becoming his assistant. Benussi was conducting research into the use of suggestion and hypnotic techniques. Musatti later took over from him as lecturer and succeeded him as director of the Padua University Institute of Psychology.

In 1934 he established contact with Edoardo Weiss, who was then training a group of students associated with the *Rivista italiana di psicoanalisi* in Rome. Musatti immediately joined the Società psicoanalitica italiana, which Weiss was actively forming at the time. Although race laws forced him to abandon teaching, an enlightened industrialist, Adriano Olivetti, invited him to Ivrea in 1943 to create a laboratory devoted to industrial psychology, the first of its kind in Italy.

Musatti entered a period of intense activity after the war. His *Trattato di psicoanalisi* (Treatise on psychoanalysis), published in 1949 and soon nicknamed *il freudino* (the little Freud) by students, continues to be one of his most famous and most successful books. He collaborated with the publishers of psychoanalytic texts and was a leading protagonist in introducing psychoanalysis into Italian culture.

Musatti's main contribution may be the fact that he directed the translation, along with publishers Borin ghieri, of the complete works of Sigmund Freud into Italian. In his preface in 1966 to Michel David's *La Psicoanalisi nella cultura italiana* (Psychoanalysis in Italian Culture), the same Musatti observed, not without regret, that the small number of analysts and the absence of kindred spirits had prevented him from undertaking any considerable research and forced him to focus essentially on facile vulgarization that was devoid of any real originality.

As a lay analyst, Musatti contributed to propagating and developing psychoanalysis in Italy, finding the means to enable it to enter cultural debates—ranging from psychology to art and jurisprudence to literature—and introducing Freudian thought with skill and talent into domains where resistance was great. All of this he accomplished without perhaps realizing the importance of *Laienanalyse* (lay analysis) for psychoanalysis. As it happened, in the *Complete Works* published under Musatti's editorship, Freud's essay (1926e) was mistranslated as *Analisi dei non medici* (Analysis of non-physicians).

A keen observer and frequently ironic, even with himself, he was the author of several books that were also intended for the general public, among them: *Curar nevrotici con la propria autoanalisi* (Treating neuroses with the appropriate self-analysis; 1987) and *Chi ha paura del lupo cattivo?* (Who's afraid of the big bad wolf?; 1987). In his last work, *Psicoanalisti e pazienti a teatro, a teatro!* (Psychoanalysts and patients

to the theatre, to the theatre!; 1988), Musatti concentrated particularly on discovering the links between psychoanalysis and theatre in order to introduce the common ground between these two fields into the "internal theatre" of each human being.

GIANCARLO GRAMAGLIA

See also: Italy; *Opere (writings of Sigmund Freud)*; *Trattato di psicoanalisi*.

### Bibliography

David, Michel. (1966). *La psicoanalisi nella cultura italiana*. Torino: Boringhieri.

Freud, Sigmund. (1926e). The question of lay analysis, *SE*, 20: 177–250.

Musatti, Cesare. (1949). *Trattato di psicoanalisi*. Torino: Boringhieri-Einaudi.

———. (1987). *Chi ha paura del lupo cattivo?* Rome: Riuniti.

———. (1987). *Curar nevrotici con la propria autoanalisi*. Milan: A. Mondadori.

———. (1988). *Psicoanalisti e pazienti a teatro, a teatro!* Milan: A. Mondadori.

---

## MUSIC AND PSYCHOANALYSIS

Sigmund Freud's attitude toward music was very ambivalent. He described himself as being *ganz unmusikalisches* ("totally unmusical"), despite his familiarity with certain operas, such as *Don Giovanni* and *The Marriage of Figaro*. In his view, the danger with music was that of losing the rational mastery that he had fixed as his objective.

Historically, the confrontation between these two realms first appeared in the work of Theodor Reik (1888–1969), notably in *The Haunting Melody: Psychoanalytic Experiences in Life and Music* (1953), where Reik took up the theme of the "haunting melody" in Freud's *Introductory Lectures on Psychoanalysis* (1916–17 [1915–17]) to demonstrate, by contrast to Freud, who was interested only in text, that musical structure can represent feelings. In Reik's view, melody can convey emotion far better than words.

There is doubtless a specific mode for mentally registering music that belongs to the preverbal period: Music has been posited as the representation of affect.

From contemporary data on intrauterine and postnatal life, it is known that vocal sounds that are emitted or heard are accompanied by various affects, many of which have no equivalent in language but remain registered in the body's memory. Longing for a sense of oneness refers to the attunement of the mother's voice to that of the infant prior to the establishing of a transitional space. Thus, in the earliest part of life the mother's voice is indissociably linked both to harmonious, reassuring feelings and to deathly anxieties of being swallowed up. For Daniel Stern, the changing and discontinuous feelings that make up the fabric of the infant's mental life can be conceived in terms of musical metaphors: Musical tempo is what best captures the mental rhythms of this period of life.

Music is a code of signifiers—a coherent whole subject to certain laws—that structures time. It thus has a therapeutic value. Music therapy, which as of the early twenty-first century is still not sufficiently well defined or systematized, uses listening to and producing music to treat various disorders, ranging from psychosis to neurotic issues, in either individual or group therapy. In psychoanalysis proper, moreover, some analysts are growing more interested in that which is vocal and yet nonverbal: that which is linked, in the analyst, to his or her maternal role and, in the patient, to the movement of his or her affects.

MARIE-FRANCE CASTARÈDE

*See also:* Graf, Max; Group psychotherapy; Listening; Literary and artistic creation; Non-verbal communication; Reik, Theodor; Repetition; Self-object.

### **Bibliography**

- Castarède, Marie-France. (1991). *La Voix et les Sortilèges* (3rd edition). Paris: Les Belles Lettres.
- Freud, Sigmund. (1916–1917 [1915–1917]). Introductory Lectures on Psychoanalysis. Parts I and II, *SE*, 15: 9–239; Part III, *SE*, 16: 240–258.
- Mijolla, Alain de. (1982). En guise d'ouvertur. . . . In Jacques Cain, et al. (Eds.). *Psychanalyse et Musique*. Paris: Les Belles Lettres.
- Mijolla, Alain de (ed.). (1993). *À la musique*. Paris: Les Belles Lettres.
- Reik, Theodor. (1953). *The haunting melody: Psychoanalytic experiences in life and music*. New York: Farrar, Straus, and Young.

### **Further Reading**

- Cheshire, Neil M. (1996). The empire of the ear: Freud's problem with music. *International Journal of Psychoanalysis*, 77, 1127–1168.
- Feder, S., Karnel, R., and Pollock, G. (Eds.). (1990). *Psychoanalytic explorations in music*. Madison, CT: International Universities Press.
- Feder, Stuart. (Ed.). (1993). *Psychoanalytic explorations in music: Second series*. Madison, CT: International Universities Press.
- Kohut, Heinz. (1957). Observations on the psychological functions of music. *Journal of the American Psychoanalytic Association*, 5, 389–407.

## **MUTATIVE INTERPRETATION**

The notion of *mutative interpretation* was advanced by James Strachey in a lecture delivered to the British Psycho-Analytical Society in 1933. With remarkable clinical acumen, he described a privileged interpretative lever whose goal is to encourage, within the framework of the transference process itself, recognition of the archaic nature of certain instinctual impulses, especially aggressive ones, thus bringing about in-depth change in the patient's neurotic organization.

Through at least a slight degree of submission to the analyst's superego-like aspect, the patient necessarily becomes aware of the instinctual contents that motivate him or her, because the analyst, owing to the transference, is the object of the patient's unconscious instincts. If all goes well, the patient becomes aware of the gap between the aggressive nature of his or her feelings and the analyst's attitude; the patient will thus recognize that there is a difference between his or her original fantasmatic object and the real, external object.

The key point in Strachey's conception revolves around the "breach" thus created within the "neurotic vicious circle": realizing that the external object is not actually endowed with the aggressiveness attributed to it, the patient will reduce his or her own aggressiveness toward the object, enabling him or her to introject a less aggressive object. In consequence, his or her superego will become less aggressive, and the patient will gain increased access to his or her infantile material.

Of course, the analyst is a part of this movement. Strachey emphasized that the three classic phases of

the interpretative dynamics—becoming aware of a state of tension within the ego, showing the means of repression, then uncovering the unconscious instinct responsible for the pressure from the superego—must in practice be carried out in conjunction, little by little, in order for the effects of “mutative interpretation” to develop in these three directions. In his view, mutative interpretation underscores the idea that change occurs on a “small scale”: only small quantities of instinctual energy are displaced.

In contrast to the more recent hypotheses of the advocates of “self-exposure,” Strachey emphasized another corollary: It is essential that the analyst’s attitude remain based on analysis of the countertransference and that it not veer off course and become a direct emotional response, even one that is positive. He reiterated that the ongoing risk of the analytic situation is that it will “degenerate” into a real-life situation; having become, without realizing it, a real object, the analyst would then become more difficult for the patient to distinguish from the seductive or persecutory object, thus hindering the interpretation’s effectiveness in bringing about change.

JACQUES ANGELERGUES

*See also:* Interpretation; Strachey, James Beaumont.

### **Bibliography**

Strachey, James. (1934). The nature of the therapeutic action of psycho-analysis. *International Journal of Psycho-Analysis*, 15, 127–159.

## **MUTUAL ANALYSIS**

Sándor Ferenczi viewed mutual analysis, a late notion in his work, as an active form of counter-transference that attempted to resolve the blockages encountered by classical technique in cases of particularly difficult patients. It was admittedly an unsuccessful innovation, but it remains useful as a limit case for any approach to the psychoses.

Ferenczi developed this technique in his *Clinical Journal* of 1932 (1988) and supported it with many detailed examples. It aims at allowing a patient in an intense regressive state not to be blocked by the treatment itself. In this active counter-transference, an illusory sense of reciprocity and a temporary symmetry need to be established so that with the trust thereby

offered, the patient can gain access to the analyst’s unconscious. This paradoxical attitude shows intuition taken to an excessive degree, since the perverse side effects of the technique are soon seen to be worse than the original difficulties encountered. So that he could struggle against “mutual co-subordination,” Ferenczi doubled the very double bind that he was attempting to lift—a process that he described very clearly: “The exaggerated emphasis on the analytic situation against the patient’s emotional convictions, makes him feel as if he has been coerced into a difficult position by means of suggestion” (1988, p. 96).

Ferenczi himself went on to establish the limits of his technique, since he detected a risk of paranoia in it. He concluded that it was a “last resort, rendered necessary by the insufficiently deep analysis of analysts.” The classical technique had become, in his view, too pedagogical because of Freud’s repugnance toward psychotics and pervers. In spite of his critique, Ferenczi acknowledged his own theoretical dependence on Freud and maintained that “the best analyst is a cured patient.”

These thoughts on the handling of the counter-transference have given rise to several innovations among therapists treating the psychoses. Harold Searles developed the notion of the child as therapist of the adult and the patient as therapist of the analyst, as well as the notion of the “attempt to drive the other mad.” Donald Winnicott, noting the “hatred in the counter-transference,” pointed out that “technical purity is only an idealization in the Freudian sense, and abets repression.” Finally, Michael Balint emphasizes that in the area of the basic fault, “words are not quite reliable” (p. 166).

PIERRE SABOURIN

*See also:* Framework of the psychoanalytic treatment; Resolution of the transference; Technique with adults, psychoanalytic.

### **Bibliography**

Balint, Michael. (1968). *The basic fault: Therapeutic aspects of regression*. London: Tavistock Publications.

Ferenczi, Sándor. (1988). *The clinical diary of Sándor Ferenczi* (Michael Balint and Nicola Zarday Jackson, Trans.). Cambridge, MA: Harvard University Press. (Originally written in 1932)

Searles, Harold F. (1965). *Collected papers on schizophrenia and related subjects*. New York: International Universities Press.

Winnicott, Donald W. (1949). Hate in the counter-transference. *International Journal of Psycho-Analysis*, 30, 69–74.

## MYSTICISM

Mysticism is a set of beliefs and practices evoking an intimate union of man and the principle of being (god or divinity). The term *mystic* (*mystisch*) appears in *The Interpretation of Dreams* (1900a). In its March 20, 1907, session, the Vienna Psychoanalytic Society listened to a talk by Adolf Häutler on “Mysticism and the Comprehension of Nature,” with critical comments by Adler, Rank, and Freud.

Mysticism was understood at that time in a pantheistic sense, as a union of man and nature and of nature with God. In a related sense, Freud “reserved for mysticism a consciousness of the inanimate,” that is of matter and the mineral world (1915e).

The discussions between Freud and Romain Rolland on the “oceanic feeling” and “Universal river” partook of the same pantheistic atmosphere that the French writer was fond of attributing to the “Germanic soul,” and that he had borrowed from Indian thought. The feeling for nature and the idea of God were combined in a communion that drew equally on art and religion. For his part, however, Freud wrote to Rolland, on July 20, 1929, “I have as little appreciation for mysticism as I do for music.”

Unlike Carl Jung, Freud was distinctly reticent about mysticism, which he felt had more to do with nature than with culture, more to do with intuition (if not drives) than with reason. Near the very end of his life, on August 22, 1938, he wrote in his notes: “Mysticism, the obscure self-perception of a kingdom outside the ego, or id.” This obscurity, according to Freud, is not unrelated to the “dark continent” of the female psyche.

But although he seemed to reject mysticism, Freud acknowledged an irrational element in himself: the residue of his self-analysis, which he called “the specifically Jewish nature of [his] mysticism.” Moreover, he loved mystery and wrote to Fliess (June 12, 1900) that he had dreamt of a marble plaque on his house that read:

In this house,  
on July 24, 1895,  
the mystery of the dream was revealed  
to Dr. Sigmund Freud.

ODON VALLET

See also: *Disturbance of Memory on the Acropolis*, A; Jung, Carl Gustav; Oceanic feeling; Rolland, Romain Edme Paul-Emile.

## Bibliography

Freud, Sigmund. (1915e). The Unconscious. *SE*, 14: 159–204.

———. (1970). *Letters of Sigmund Freud, 1873–1939*. (Ernst L. Freud, Ed.; Tania and James Stern, Trans.). London: Hogarth.

Häutler, Adolf. (1962–75). Scientific meeting, March 20, 1907: Mysticism and the comprehension of nature. In Herman Nunberg and Ernst Federn (Eds.), *Minutes of the Vienna Psychoanalytic Society* (M. Nunberg, Trans., Vol. 2, 1906–08). New York: International Universities Press.

Jung, Carl Gustav. (1980). The psychology of the transference. *Coll. Works*, Vol. 16. London: Routledge & Kegan Paul.

Vermorel, Henri, and Vermorel, Madeleine. (1993). *Sigmund Freud et Romain Rolland. Correspondance 1923–1936*. (Alain de Mijolla, Ed.). Paris: Presses Universitaires de France.

## MYTH OF ORIGINS

Freudian thought on origins translates an effort to think the extraindividual, in order to anchor the subject within the ancestral lineage and the history of the species as well as within biology. Several modalities can be discerned: the myth of origins; the genetic myth—the foundational role of the drives as a substrate of the psyche; and primal fantasies and/or fantasies of origins.

Neither maternal nor natural, the myth of origins in the work of Sigmund Freud from the outset placed the history of humanity at the horizon of the paternal function: The original myth is held to be that of the murder of the father. This Freudian theory posited the murder of the primitive father as the starting point for humanity and society. The hypothesis must be understood not as historical truth but as a working myth that expresses the posited requirement that each human being, in the words of Freud, be “an offshoot of Oedipus.” Put forward by Freud in *Totem and Taboo* (1912–1913) and taken up again in *A Phylogenetic Fantasy: Overview of the Transference Neuroses* (1985a [1915]), this myth retraces the history of the primitive horde ruled by a tyrannical father who requires total submission of his sons and exclusive ownership of all the females. However, the brothers form a coalition to kill the father, and devour him in a cannibalistic

celebration. They then erect a totem representing the father and impose a prohibition against incest. This symbolic pact and the rules that result from it constitute the beginnings of society.

Freud elaborated this myth of origins in light of his readings in ethnology and anthropology, analyzing the meanings of totems and taboos in so-called primitive societies. This enabled him to observe that totemic activity coincided with exogamy, that is, the neutralization of the practice of incest. Freud asserted in *Totem and Taboo*: “The violent primal father had doubtless been the feared and envied model of each one of the company of brothers: and in the act of devouring him they accomplished their identification with him, and each one of them acquired a portion of his strength. The totem meal, which is perhaps mankind’s earliest festival, would thus be a repetition and a commemoration of this memorable and criminal deed, which was the beginning of so many things—of social organization, of moral restrictions and of religion” (p. 142). Elsewhere, he pointed out that in the Christian myth, the original sin was the result of an offense against God the Father. By sacrificing his own life to free men from this sin, Christ tends to reconcile humankind with God the Father. Through his sacrifice, the son himself becomes God in place of the father. The religion of the son replaced the religion of the father. To mark this substitution, the old totemic meal was revived: The communion was instituted, in which the gathered brethren eat and drink the flesh and blood of the son, rather than the father, to sanctify themselves and identify with him. At the same time, noted Freud in “Totem and Taboo,” a “sense of guilt for an action has persisted for many thousands of years and has remained operative in generations which can have had no knowledge of that action” (p. 158).

In this regard, Jacques Lacan believed that Freud had implicitly assumed that “a forgotten drama traverses the ages in the unconscious,” as he wrote in *Écrits* (1966/2002); he deduced from this that the true father, “the symbolic Father, insofar as he signifies this Law, is truly the dead Father” (p. 189). More specifically, according to Lacan, “it is thanks to the Name-of-the-Father that aggression against the Father is at the principle of the Law and that the Law is in service to the desire it institutes by the prohibition against incest.”

What we find to be of primordial importance in the reading of this myth is that the murder of the father is repeated by the sons during the religious ritual in the

form of sacrifice; this constitutes the symbolic pact among the brothers, who thus celebrate the restoration of authority, in which they participate from that point on. It is this precise moment that we consider to be the cornerstone of hominization and of culture (Kristeva, 1996). In Freud’s view, on the individual level we are all, unbeknownst to ourselves, repositories of this myth of origins, which each of us reactualizes through the realization of his or her Oedipus complex; he considered the latter, as he wrote in “Totem and Taboo,” to constitute “the beginnings of religion, morals, society and art” (p. 156) and also “the nucleus of all neuroses” (p. 157). He was later led to reintegrate into his inquiries into origins the maternal function, seemingly evacuated from this myth, by discovering an early link between mother and daughter that he compared to Minoan-Mycenaean culture, long hidden by Athenian culture.

By extension, thinking about origins appears in the form of an anchoring of the psyche in the *archè* of biology, expounded initially in Freud’s correspondence with Wilhelm Fliess between 1887 and 1902 (*Extracts from the Fliess Papers* [1950]) and later in “A Metapsychological Supplement to the Theory of Dreams” (1915), “Negation” (1925), and “An Outline of Psychoanalysis” (1940). For the father of psychoanalysis, there could be no doubt that psychic life originated in the organism and that it could thus be conceived of as an evolved form of biological life. This bracketing together of the two is conceptualized in terms of analysis, with self-preservation serving as a support to the libido. Also resulting from this is the essential place of the drives as a borderline concept between the somatic and the psychic. In this spirit, in his “metapsychological” essays Freud advanced the hypothesis of an innate “unconscious kernel,” around which agglomerates all that the individual represses in the course of development. This explains how the unconscious can be organized in the same way in all individuals and how it can be made intelligible in and through psychoanalysis. To attach the psychic apparatus to this biological reservoir, Freud proposed the models of his two topologies (*Ucs./Pcs./Cs.*; *id/ego/superego*). He was at pains in “Negation” to establish the steps and modalities of this transformation of the drive into meaning and, to this end, he emphasized the role of language, which provides an alternative trajectory for pulsional negativity by demarcating the pathway of thought and the symbolic. In analysis, the coming to awareness of the primal repressed is often manifested by means of the

symbol of negation, in which thought is freed from the limitations of repression.

The primal fantasies that are fantasies of origins (observation of the parents' sexual relations, seduction, castration) make up the third panel in the triptych of Freudian thinking on origins. On the one hand, these fantasies have an object that allows infantile sexual curiosity inevitably to confront the question of "where babies come from." On the other, hereditary mnemonic traces are organized into scenes developed by narrative scenarios, with these foundations encompassing conceptual forms or "schemes whose fundamental property is their polarizing, organizing, and classifying role," as André Green put it in "Penser l'originaire" (1991; Thinking the primal). Fantasies of origins are anterior to any individual experience; present in the form of phylogenetic mnemonic traces, they thus belong not to the historical part of the psyche, but to a transmissible heritage. These schemes, which require a phylogenetic explanation, are justified according to Freud by reality as a missing link in individual psychic experience and are related through it to humanity's archaic past, during which, for example, castration was presumably actually practiced by the father on his sons, as he conjectured in *A Phylogenetic Fantasy*.

It could be submitted, in conclusion, that the Freudian "ur" transcends the limits of the individual to move toward the history of the species (in a Darwinian perspective) and toward being (in a phenomenological perspective), with the subject appearing, in Lacan's formulation, as a "parlêtre" (being-through-speaking).

JULIA KRISTEVA

*See also:* Organic repression; Parricide; Primal fantasies; Primary identification; Primitive; Primitive horde; Totem/totemism.

### **Bibliography**

- Freud, Sigmund. (1912–1913a). Totem and taboo. *SE*, 13: 1–161.
- . (1916–1917g [1915]). A metapsychological supplement to the theory of dreams. *SE*, 14: 217–235.
- . (1925h). Negation. *SE*, 19: 233–239.
- . (1940a). An outline of psycho-analysis. *SE*, 23: 139–207.
- . (1950a). Extracts from the Fliess papers. *SE*, 1: 173–280.

———. (1985 [1915]). A phylogenetic fantasy: Overview of the transference neuroses (Ilse Grubrich-Simitis, Ed.; Axel Hoffer and Peter T. Hoffer, Trans.). Cambridge, MA: Belknap Press of Harvard University Press.

Green, André. (1991). Penser l'originaire. *Topique*, 49.

Kristeva, Julia. (2000). *The sense and non-sense of revolt* (Jeanine Herman, Trans.). New York: Columbia University Press. (Original work published 1996)

Lacan, Jacques. (2002). *Écrits: A selection* (Bruce Fink, Trans.). New York: W. W. Norton. (Original work published 1966)

---

## **MYTH OF THE BIRTH OF THE HERO, THE**

In Otto Rank's view, this book was the first to attempt a psychoanalytical interpretation of myths: In it he declared that psychological reality is responsible for organizing what is narrated by the myth or the story. This work, a "cornerstone" of the psychoanalytical study of mythology (Theodor Reik), and written at Freud's request, did indeed open up original perspectives in the methodological approach to the problem of the formation and function of myths.

Breaking away from the naturalist analysis of mythology, Rank founded his study on the parallel between dream and myth and on the concept proposed by Freud of the "family romance of neurotics." Rank also composed a *Legend of Lohengrin* (1911) in which he tested out his hypotheses and convincingly demonstrated their plausibility.

*The Myth of the Birth of the Hero* is in three parts. In the first, Rank establishes the universality of the myth of the hero; then he sets out his central hypothesis by bringing out the role played by unconscious psychosexual life in myth formation. When it comes to the myth of Oedipus, Rank emphasizes the resistance aroused by the psychoanalytical hypothesis, opposed as it is to the naturalist interpretation, which sees in myth nothing more than personified natural processes. In the second part, Rank surveys a wide range of myths, eighteen in all, garnered from different cultures: Babylonian, Hebrew, Greek, Germanic, Celtic, and Latin. Then he isolates their recurrent themes so as to bring out the structure of what he calls a "typical legend." The myths of Gilgamesh, Cyrus, Moses, Jesus, Oedipus, Tristan, Romulus, Siegfried, and Lohengrin are all analyzed in this way. The survey is completed in part three by references to research on Melanesian, Mexican, North American, African, and other corpuses.



The third part of the work centers on uncovering the typical legend from characteristic elements encountered in the survey, which Rank summarizes in these terms: the hero is the child of parents from a high stratum of society, often of divine or royal origin; his birth is preceded by difficulties in his conception (chastity, sterility, clandestine intercourse). During pregnancy, a presage warns of this birth and announces that the child's father is in danger; as a result, the child is condemned to death by exposure, usually on the initiative of the father or a substitute figure, and more often than not he is set adrift in a casket; the child is then saved and suckled by an animal or by a woman of humble condition; once he has grown up, he undergoes many adventures during which he finds his noble parents and takes revenge on his father; he is recognized and attains glory and renown.

Rank leaves to the process of interpretation the task of bringing out the meaning of the typical legend: this is a rigorous and relatively modern position, that draws support from divergences or variants between myths in order to establish or question the hypotheses proposed. The overall pattern of his interpretation can be seen in the way typical dreams shed light on the analysis of different elements of the myth. His analysis is thus conducted like that of a dream: a myth is the realization of an unconscious desire, and myth is constructed by the same processes as dream—displacement, condensation, considerations of representation, and symbolization.

Rank provides a precise analysis of certain of the myth's elements, starting out from typical dreams: thus the hidden meaning of the "mytheme" of exposure is elucidated by the analysis of dreams of birth, which leads him to suppose that "the same symbolic expression dominates the language of dream and that of myth simultaneously." The desire expressed by the myth of the hero is the oedipal desire for triumph over the father, and the theme of rebellion against the father, which dominates in the theme of exposure, also illuminates the theme of the father's secondary elevation to the rank of king and the theme of rescue. The concept of the "family romance of neurotics" allows Rank to specify how, in the imagination of pre-pubertal daydreams as well as in myth narratives, we find represented both the desire to get rid of parents for whom one feels little esteem and replace them by others who are nobler and more prestigious, and at the same time questions about the knowledge of sexual processes,

procreation, birth, and the mother's body. This parallel between the tendency to family romance and the tendency to evoke the myth of the hero means that Rank can establish an analogy between the ego of the child and the hero. Rank notes that in literary creation the hero represents the poet himself, an idea that Freud took up at the end of *Group Psychology and the Analysis of the Ego* (1921c).

The work ends with two important considerations: the one concerns the genesis and function of the myth of the hero in social life and in individual and collective processes of identification; the other concerns the pathological role of the hero and the relations between myth and delirious fantasies of descent.

The wealth of themes dealt with in this book, and the originality of its approach, meant that it became extremely influential: It inspired major works by Géza Róheim and Carl G. Jung, among others.

RENÉ KAËS

*See also:* Birth: Hero (myth of the); *Moses and Monotheism*.

### Source Citation

Rank, Otto. (1909). *Der Mythos von der Geburt des Helden*. Leipzig-Wien: F. Deuticke; (1952). *The myth of the birth of the hero; A psychological interpretation of mythology*. (F. Robbins and Smith Ely Jelliffe, Trans.). New York: R. Brunner.

### Bibliography

Róheim, Géza. (1945). *Eternal ones of the dream: A psychoanalytic interpretation of Australian myth and ritual*. New York: International Universities Press.

Sellier, Philippe. (1970). *Le mythe du héros*. Paris: Bordas.

Valabrega, Jean-Paul. (1980). *Phantasme, mythe, corps et sens: Une théorie psychanalytique de la connaissance*. Paris: Payot.

---

## MYTH OF THE HERO

The concept of the *hero* is consubstantial with that of *myth*: they evolved together through the ages. Myths relate the exploits of a man, most frequently the son of a god and a mortal, or of a goddess and a mortal, endowed with extraordinary value and destined to carry out glorious exploits, especially an act of protection or rescue. From a psychoanalytic perspective, the heroic myth has its roots in the fantasy of the family

romance. It expresses and sustains the identification of the ego with an idealized imago, especially during adolescence. It is an essential aspect of training for groups and institutions.

It is difficult to assign a date to the origin of myth. Several authors consider the epic of Gilgamesh to be one of its first expressions. The structure of the myth of the hero has gradually been deduced from the analysis of classical works (Assyrian epic poems, biblical tales, Greek and Latin mythologies), and it can be confirmed in the chansons de geste and epic theater, as well as the modern novel. In spite of the diversity of forms, in the end it remains anthropologically invariant.

Several disciplines have contributed to determining the structure, content, and functions of the myth of the hero: literary criticism, the history of religion, mythology, and with the important work of Otto Rank (*The Myth of the Birth of the Hero*, 1909/2004), psychoanalysis. Rank emphasized the family romance as the organizational schema for the myth of the hero and heroic identification. The structure common to representations of the myth establishes the characteristic elements of the development of the hero:

- conception from illustrious parents, either divine or representatives of the divinity; amazing deeds, oracles, miracles, or prophecies that generally threaten the father prior to the birth of the infant;
- the birth of the hero: the threatening prophecies justify the abandonment and exposure of the child hero at the time of birth in a hostile universe once the secret of his origin has been established;
- obscurity: the hero leads a secret life and will have to undergo an apparent death, from which he will be saved before having to confront terrible challenges;
- the ordeal and epiphany of the hero: critical confrontations (the monstrous) force the hero to confront persecution and depressive anxieties and transform him into a recognizable hero;
- the recognition of his triumph, of his glory, and brilliance (solarity): his apotheosis as an immortal alters him. He can then be used as a model for imitation by mere mortals.

RENÉ KAËS

*See also:* Birth; *Group Psychology and the Analysis of the Ego*; Heroic identification; Heroic self; *Moses and Monotheism*; *Myth of the Birth of the Hero*, *The*; Parricide; *Psychology of the Unconscious*, *The*; Reversal into the opposite.

### **Bibliography**

- Albouy, Pierre. (1969). *Mythes et Mythologies dans la littérature française*. Paris: Armand Colin.
- Baudouin, Charles. (1952). *Suggestion and autosuggestion, a psychological and pedagogical study based upon the investigations made by the New Nancy School*. Eden and Cedar Paul, Trans. London: G. Allen & Unwin.
- Dumézil, Georges. (1968). *Mythe et Épopée, I*. Paris: Gallimard.
- Rank, Otto. (2004). *The myth of the birth of the hero: A psychological interpretation of mythology* (Gregory C. Richter and E. James Lieberman, Trans.) Baltimore, Md.: Johns Hopkins University Press. (Originally work published 1909)
- Sellier, Philippe. (1970). *Le Mythe du héros*. Paris: Bordas.

---

## **MYTHOLOGY AND PSYCHOANALYSIS**

The closest psychoanalytic definition of the term *mythology*, found in dictionaries, is a “set of beliefs and ideas about a single concept imposed on the members of a group.” Professor Jean Rudhart of the University of Geneva notes that a myth is a story that “signifies differently than conceptual speech and contains a deep meaning that is distinct from its surface meaning” (1981).

We can assume that, for Sigmund Freud, myth, “signifying differently” and distinct from the apparent meaning of conceptual speech, represented “with the introduction of the reality principle one species of thought-activity [that] was split off; it was kept free from reality-testing and remained subordinated to the pleasure principle alone” (1911b, p. 222). We can easily recognize the creation of fantasies described in Freud’s “Formulations on the Two Principles of Mental Functioning” (1911b). In the same sense the role of myth, collective or individual, would correspond to the religious and cultural fantasies that influence, introduce, or modify ego ideals and the pre-oedipal and post-oedipal superego; they also promote various identifications and sublimations. Additionally, mythology, being a part of the cultural heritage of the collectivity, and transmitted “phylogenetically” or diachronically through oral traditions, contributes to the

formation of primal fantasies, the family romance, and “cultural romances” (Nicolaidis, 1988).

A distinction between myth (the production of desire through fantasy) and history (an event-driven narrative corresponding to the reality principle) could be made through the use of the concepts of conjunction and structure. In this sense history would be a “conjunction” having an event-driven continuity and a fantasy-driven discontinuity, while mythology (myths) would be a “structure” having a fantasy-driven continuity and an event-driven discontinuity. However, myth structures the desire of a group of individuals. This distinction brings us back to Freud’s abandonment of his *neurotica*, of the actual seduction (letter to Fliess, October 15, 1897), which until then had been the etiology of the neuroses (event-driven history). To ground his new theory, he made use of the Oedipus myth and the history of Hamlet, as dramatized by Shakespeare.

In this way the Oedipus complex was born as humanity’s universal core. Later on, the myth of Narcissus (1914) became the link between the first and second topographical subsystems. We know that throughout his work Freud made reference to mythic characters and contexts as metaphors for the evolution of psychic reality. He clearly expressed the closeness between myths and fantasies, the products or creations of drives, when he wrote, “The theory of instincts is so to say our mythology. Instincts are mythical entities, magnificent in their indefiniteness” (1933a, p. 95). The fact that the role of myth in psychoanalytic theory is obvious presents the following questions: Why was Freud’s thinking, influenced by the neopositivism of his time, oriented toward myths? Why did he emphasize some myths and ignore others?

At the beginning of his career, Freud constructed a “psychic apparatus” that he tried to connect with the neuroses (*Project for a Scientific Psychology*, 1950c [1895]), but he repudiated the essay for the remainder of his life. He did so following the introduction of psychic reality, although the concept forced him to contradict the scientific and cultural climate of his age and his own tradition as a neurologist. For, to some extent, he separated the psyche from its biological substrate. But by claiming to be an atheist, and certainly an agnostic, there was no question for Freud of attaching the psyche (the soul) to religion, or a mystical or metaphysical concept. On the other hand, because he acknowledged that the illusion he criticized played an

important role in the shared life of mankind, he sought this illusion (of the imagination) in myth. Because fantasy fell halfway between the real and the imaginary, myths, at least some of them, fell somewhere between the mysticism of religion and the reality of desire. Thus the mythologies closest to the mental apparatus and psychosexual evolution reinforce and are mirrored in his conception of “psychic reality”.

Reading the index to the *Standard Edition*, we find that *Faust* and *Hamlet* are the most frequently cited texts. With respect to mythic texts strictly speaking, Greco-Roman mythology is the most prevalent. Germanic-Scandinavian mythology is absent in Freud’s writings. The mythology and art of Egypt are of interest to Freud and he writes often of Amenophis IV–Akhenation (with respect to monotheism) and he mentions Isis and Osiris. He is familiar with the Brihad-Aranyaka Upanishad of India, where the genesis of the world is described on the basis of the *Aturan* (the self or ego); he quotes Ramakrishna and Vivekananda but never the *Veda* or the revelations of Brahma. The Buddhist concept of nirvana serves as a metaphor of instinctual economy. He also cites the epic of Gilgamesh. The Bible is found throughout his work but as a religious reference rather than a mythic context. He does comment on the dilemma of Abraham and Isaac, and the dream of Solomon, but for Freud the mythical hero of the Bible is Moses, because of his strength and spirituality. Fascinated by Roman statuary, especially Michelangelo’s *Moses*, Freud devoted his last book to the legend of Moses. *Moses and Monotheism* (1939a [1934–1938]) is an anthropological construct, where the eternal Freudian quest for the origin of mankind and the evolution of civilizations unfolds, especially in the transition from the matriarchy to the patriarchy, which is presented as a victory of spirituality over sensuality. Concerning this, Freud writes, “An echo of this revolution seems still to be audible in the *Oresteia* of Aeschylus” (p. 114).

But it is *Totem and Taboo* (1912–13a) that unquestionably remains Freud’s laboratory on the question of origins, primal fantasies, and the origin of fantasy, even the origin of myth and its role in structuring “psychic reality”. In the first part of the book, Freud generalizes his thinking, quoting several historians of primitive peoples, but without reference to a specific mythology. In evoking the guilt arising from the totemic meal, or “tragic fault,” he writes, “In particular, I have supposed that the sense of guilt for an

action has persisted for many thousands of years and has remained operative in generations which can have had no knowledge of that action” (pp. 157–158). The first two-thirds of the book refers to the fear of incest, to taboo, and the ambivalence of the feelings associated with animism, magic, and the omnipotence of ideas. Throughout the work Freud attempts, using analogies from mythology, to structure this primitive-instinctual inconsistency, sometimes expressed by legends dominated by magical or animist thought, with a kind of anthropological coherence. The omnipotence of ideas provides him with an opportunity to quote Hamlet and create a connection between animist thought and obsessive representations, but it is chapter IV, “The Return of Totemism in Childhood,” that marks a turning point toward “Occidental” psychopathology and the mythology that masks it.

Freud gradually abandoned pre-Hellenic “mythology,” which had been necessary until then to identify primitive thought. In analyzing totemism and the totem meal, he notes that their content coincides (1912–13a, p. 132). He begins with the sacrifice, “the sacred act par excellence,” quoting often from *The Religion of the Semites* (1889) of W. Robertson Smith: “The primitive animal sacrifice was already intended to replace a human sacrifice, the solemn killing of the father.” Freud remarks that, analogically, Christ, in sacrificing his own life, freed all other men from original sin. However, the doctrine of original sin for Freud is of Orphic origin. To support his hypothesis he introduced the pre-Olympian myths (Orphism), the Titans, who killed and cut into pieces the young Dionysus-Zagreus. Using this information, Freud again returns to Greco-Roman mythology to house the fantasies and psychopathology of his psychoanalytic theory. By insisting on the importance of the “tragic fault,” he writes that “the beginnings of religion, morals, society and art converge in the Oedipus complex. This is in complete agreement with the psychoanalytic finding that the same complex constitutes the nucleus of all neuroses, so far as our present knowledge goes” (1912–13a, p. 156). He shows that the “modernity” of this myth conforms to the actuality of the neuroses of the modern world.

Freud, in “Why War?” (1933b [1932]), wrote to Albert Einstein, “It may perhaps seem to you as though our theories are a kind of mythology and, in the present case, not even an agreeable one. . . . Our mythological theory of instincts makes it easy for us to find a formula

for *indirect* methods of combating war. If willingness to engage in war is an effect of the destructive instinct, the most obvious plan will be to bring Eros, its antagonist, into play against it” (p. 212).

In *Beyond the Pleasure Principle* (1920g), he situated this antagonism: “If . . . we are not to abandon the hypothesis of death instincts, we must suppose them to be associated from the very first with life instincts. But it must be admitted that in that case we shall be working upon an equation with two unknown quantities” (p. 57). Here, Freud acknowledges his scientific dissatisfaction and refers to a myth, an “instinct to restore an earlier state.” This is the myth of Aristophanes in the *Symposium* of Plato, where there is a question of the primal physical bisexuality of human beings. He mentions this myth again in “Why War?”

Greco-Roman mythology fascinated the inventor of psychoanalysis not only because of its consistency in terms of fantasy (Didier Anzieu, 1970; André Green, 1969/1979; Graziella Nicolaïdis, Nicos Nicolaïdis, 1994), but also because of the role of Eros and sexuality in this mythology-religion, where carnal pleasure was not considered a sin but as a right that God or nature had given to man. This mythology alleviated Freud’s guilt, so to speak, by legitimizing infantile sexuality and adult sexuality, the fruits of his own discovery.

To conclude, it can be said that mythology and some myths or “mythemes,” condensing and displacing the representations of drives, have served as metaphorical models for several fundamental fantasies in the theory of psychoanalysis.

NICOS NICOLAÏDIS

*See also:* Alpha-elements; Amplification (analytical psychology); Animistic thought; Applied psychoanalysis and the interaction of psychoanalysis; Archaic mother; Archetype (analytical psychology); *Autobiographical Study, An; Beyond the Pleasure Principle*; China; Complex; Cultural transmission; Dream symbolism; Eros; Fascination; Heroic identification; Interpretation of dreams (analytical psychology); Jung, Carl Gustav; Myth; Narcissism; Oedipus complex; Projection and “participation mystique” (analytical psychology); *Psychoanalysis of Fire, The; Psychology of the Unconscious, The*; Reverie; Reversal into the opposite; Screen memory; Secret; Self (analytical psychology); Sociology and psychoanalysis, sociopsychology; State of being in love; “Theme of the Three Caskets, The”; Transgression.

### Bibliography

- Anzieu, Didier. (1970). Freud et la mythologie. *Nouvelle revue de psychanalyse*, 2, 114–145.
- Freud, Sigmund. (1911b). Formulations on the two principles of mental functioning. *SE*, 12: 213–226.
- . (1912–13a). Totem and taboo. *SE*, 13: 1–161.
- Green, André. (1979). *The tragic effect: The Oedipus complex in tragedy* (Alan Sheridan, Trans.). Cambridge and New York: Cambridge University Press. (Original work published 1969)
- Nicolaidis, Nicos. (1988). *La théophagie. Oralité primaire et métaphorique*. Paris: Dunod.
- Nicolaidis, Graziella, and Nicolaidis, Nicos. (1994). *Mythologie grecque et Psychanalyse*. Paris: Delachaux & Niestlé.
- Rudhardt, Jean. (1981). La fonction du mythe dans la pensée religieuse de la Grèce. *Revue européenne des sciences sociales*, 19 (58), 177–187.

### Further Reading

- Arlow, Jacob. (1982). Scientific cosmogony, mythology, and immortality. *Psychoanalytic Quarterly*, 51, 177–195.

## MYTHOMANIA

The concept of mythomania appeared in the academic psychiatric literature at the beginning of the twentieth century. It was introduced by Ernest Dupré (b. 1905), a specialist in “constitutions,” in *Pathologie de l’imagination et de l’émotivité* (Pathology of the imagination and emotions; 1925) to refer, precisely, to the supposedly constitutional tendency of certain subjects to confabulate on the mental level and to simulate on the somatic level.

In his *Manuel alphabétique de psychiatrie* (Alphabetical manual of psychiatry; 1952), Antoine Porot devoted a relatively long article to this topic. He studied mythomania in children as distinct from mythomania in adults, recalling the three main types identified by Dupré—vanity-based mythomania, malignant mythomania, and perverse mythomania—and adding to these the particular form of errant mythomania, potentially associated with fugue states (“fables in action”).

In children, Dupré described a sort of gradient ranging from quasi-physiological mythmaking activity to true mythomania, by way of lies, pretending, and fabrication. In adults, vanity-based mythomania was posited as being the most benign clinical form, the prototype of which is illustrated by Alphonse Daudet’s

*Tartarin de Tarascon*. However, according to Dupré this type of mythomania could also be observed in cases of debility, whereas the more serious, malignant, and perverse forms were described as occasionally going as far as delusional imaginings. In this author’s view, whether mythomania was episodic or permanent, it was linked to a so-called primitive mentality, even though he believed that this disorder was more common among women and sometimes transmitted in a hereditary pattern that could affect several successive generations. According to him, mythomania was based on emotivity, exaltation of the imaginative faculties, and suggestibility, whereas Eugène Minkowski linked mythomania to the idea of “inconsistency” introduced by Pierre Janet.

The classical psychiatry of that era took an incidental interest in the connections among mythomania, simulation, and hysteria, but the climate of the times was more inclined toward the isolation of descriptive entities than toward structural reasoning. This perspective is obviously not that of psychoanalysis, which, accordingly, took relatively little interest in mythomania per se.

Michel Neyraut must be credited for taking a metapsychological approach to this disorder in “À propos de la mythomania” (On mythomania; 1960). This study enabled him to show that a symptom can register within a variety of psychic functions, and that only an in-depth study of a subject’s psychopathology from a threefold economic, topographical, and dynamic perspective can reveal the meaning and function of a symptom that seems relatively identical from one individual to another based solely on a surface behavioral description.

In addition, Neyraut’s study retraced the history of this concept with regard to the development of psychoanalytic discovery itself, with its well-known central focus on the question of hysteria.

BERNARD GOLSE

See also: Lie.

### Bibliography

- Daudet, Alphonse. (1872). *Aventures prodigieuses de Tartarin de Tarascon*. n.p.
- Dupré, Ernest. (1925). *Pathologie de l’imagination et de l’émotivité*. Paris: Payot.

Neyraut, Michel. (1960). Á propos de la mythomanie. *L'Évolution psychiatrique*, 4, 533–558.

Porot, Antoine. (1952). *Manuel alphabétique de psychiatrie*. Paris: Presses Universitaires de France.

## MYTHS

Myths are tales of unknown origin handed down by tradition, sometimes orally and sometimes by written word. The stories are set in a primordial period during which the order of the present world is established. They tell the story of the origin of the world, of human beings and animal species, of death, and of the relationship between man and supernatural beings.

Until the fifth century BCE, the Greek word *mythos* was a synonym for *logos* (word). With Pindar and Herodotus, it came to mean words of illusion; rumor; the speech of others; irrational, barbarous, even scandalous speech (Détienne, 1979). For better or worse, Western mythology inherited this opposition between rational thought and mythical thought.

When ethnologists realized that the social organizations of the peoples they studied were significantly related to their mythologies, they helped move the study of myths from the impasse that nineteenth-century authors had become stuck in. Claude Lévi-Strauss saw myths as books without authors, their messages “coming, properly speaking, from nowhere” (1969–1981). Studying native American myths in their own terms, he demonstrated that they are transformations of each other and that their different codes express an underlying logical structure. In fact, myths are not only speculations about social organization but also, and above all, they reflect the structure of the human mind (Lévi-Strauss, 1969–1981). Georges Dumézil (1968–1973) laid bare the underlying principles of social organization in ancient Indo-European mythologies, particularly regarding the functions of sovereignty, war, and fecundity.

Freud related psychoanalytic theory to mythology in the broad sense of the term (myths, tales, sayings, jokes): “It is extremely probable that myths, for instance, are distorted vestiges of the wishful fantasies of whole nations, the secular dreams of youthful humanity,” Freud wrote in 1908 (p. 152). In 1909 Karl Abraham developed this idea in *Dreams and myths* (1913) by showing that myths use the same mechanisms as dreams (figuration, condensation, displacement, and secondary revision), and that they are the

realization of desires. They can therefore be interpreted in the same way as dreams (see Otto Rank, 1952, 1975).

While Abraham used the Greek myth of Prometheus for his demonstration, Géza Róheim, a psychoanalyst and field anthropologist, directly studied Australian aborigines. For them, mythical time, the time of the primordial ancestors, is “dream time.” These aborigines’ notion of “eternal dream beings” enabled him to show “how the typical mechanism of all dream construction operates at the heart of mythology and aboriginal rituals” (Róheim, 1952).

Jean-Paul Valabrega (1967, 1992, 2001) devotes considerable attention to the epistemological question of the relation between myths and the unconscious, between myths and fantasy. For Valabrega, myths, which are neither individual nor collective, tend to metamorphose (as shown by the many different versions available) yet remain eternal and perpetually regenerate, in both respects like the unconscious. Moreover, myths are related to fantasies in that they both represent. Myths are made from the stuff of fantasies, and fantasies are made from the stuff of myths: there is a circular relationship between them in which neither is primary. “Psychoanalysis was practically born entirely out of a myth—Oedipus— . . . that Freud rediscovered by analyzing the dreams and fantasies of his first patients, as well as by analyzing his own dreams and fantasies” (Valabrega, 1994). There is also his use of mythical figures like Narcissus, Eros, and Thanatos.

The loose use of the term *myth*, encouraged if not created by Roland Barthes’s work (1970), is more a matter of ideology. This usage, Valabrega (1994) claims, preserves the “function of myths” and the “structure of symptoms.” In this usage, words without an author, productions that borrow the anonymity of myths and a few contemporary elements of content, bear witness to the persistence of a discourse that is both intimate and foreign to the self.

NICOLE BELMONT

*See also:* Anthropology and psychoanalysis; “Claims of psychoanalysis to scientific interest”; Death and psychoanalysis; Dream and myth; Drive/instinct; Group psychology and the analysis of the ego; History and psychoanalysis; Mythology and psychoanalysis; *New Introductory Lectures on Psychoanalysis*; Partial drive; *Thalassa: A Theory of Genitality*; *Totem and Taboo*; “Why War?”

**Bibliography**

- Abraham, Karl. (1913). *Dreams and myths: A study in race psychology* (William A. White, Trans.). New York: Journal of Nervous and Mental Disease Publishing Co. (Original work published 1909)
- Barthes, Roland. (1970). *Mythologies*. Paris: Seuil.
- Détienne, Marcel. (1979). Les mythologues de la cité. *Revue française de psychanalyse*, 43 (3), 355–374.
- Dumézil, Georges. (1968–1973). *Mythe et épopée* (vols. 1–2). Paris: Gallimard.
- Freud, Sigmund. (1908). Creative writers and day-dreaming. *SE*, 9: 141–153.
- Lévi-Strauss, Claude. (1969–1981). *Introduction to a science of mythology* (vols. 1–4). New York: Harper & Row.
- Rank, Otto. (1952). *The myth of the birth of the hero: A psychological interpretation of mythology* (F. Robbins and Smith Ely Jelliffe, Trans.). New York: R. Brunner. (Original work published 1909)
- . (1975). *The Don Juan legend*. Princeton, NJ: Princeton University Press. (Original work published 1922)

Róheim, Géza. (1952). *The gates of the dream*. New York: International Universities Press.

Valabrega, Jean-Paul. (1967). Le problème anthropologique du phantasme. In Aulagnier, Piera, et al. *Le désir et la perversion* (pp. 163–206). Paris: Seuil.

———. (1980) *Phantasme, mythe, corps et sens: Une théorie psychanalytique de connaissance*. Paris: Payot.

———. (1992). Le motif du jumeau: Identité-altérité. *Topique*, 50, 181–183.

———. (1994). *La formation du psychanalyste*. Paris: Payot.

———. (2001). *Mythes, conteurs de l'inconscient: Questions d'origine et de fin*. Paris: Payot et Rivages.

**Further Reading**

Hartocollis, Peter, and Graham, I. (Eds.). (1991). *The Personal Myth in Psychoanalytic Theory*. Madison, CT: International Universities Press.

Kris, Ernst. (1956). The personal myth. *Journal of the American Psychoanalysis Association*, 4, 653–681.

Millar, David. (2001). A psychoanalytic view of biblical myth. *International Journal of Psychoanalysis*, 82, 965–980.

# N M

## NACHT, SACHA EMANOEL (1901–1977)

Sacha Nacht, French physician, neuropsychiatrist, and psychoanalyst, was born at Racacini in the department of Bacau, Romania, on September 23, 1901, and died in Paris on August 25, 1977.

The son of Samuel Nacht, who was ruined financially by a fire in his sawmill, and of Cécilia Bril, Sacha Nacht completed his secondary education and first year medical studies, then emigrated to France in 1920 in order to continue his studies there, because of a *numerus clausus* limiting Jewish enrollment in Romania. The influence of Charles Foix stimulated his interest in neurology and he presented his graduate thesis in 1926: *Contribution à l'étude de l'anatomie pathologique des myélites syphilitiques en général et de leurs formes progressives en particulier* (Contribution to the study of pathological anatomy in syphilitic myelitis in general and its progressive forms in particular).

In 1926 his success (as a foreigner) in the *Internat des Asiles* (a competitive examination for trainee physicians wishing to work in psychiatric asylums) nevertheless directed him into psychiatry. Legend has it that psychoanalysis was revealed to him while he was watching Henri-René Lenormand's play, *Le Mangeur de rêve*, which triumphed in Paris in 1922, but this underestimates the importance of psychoanalysis and the first French psychoanalysts working under Professor Henri Claude in the Sainte-Anne hospital where he was soon to work.

He was analyzed for two and half years by Rudolph Loewenstein before going to Vienna where Freud received him on the recommendation of Marie Bonaparte. Being unable to understand his German, Freud

considered that it was impossible to continue the analysis and recommended that he continue his treatment with Heinz Hartmann in Vienna, a treatment they later continued in Paris when Hartmann emigrated there.

Nacht was invited to attend a conference on schizophrenia in 1927 and was elected a member of the Société Psychanalytique de Paris (SPP, Paris Psychoanalytic Society) on January 17, 1928, becoming a full member on October 21, 1929. In December 1931 he was appointed head of the psychotherapy and psychoanalysis laboratory under Henri Claude and in 1933 passed the Concours des Médecins des Asiles (a competitive examination for asylum physicians), though he never occupied a position as head of a hospital department. In 1935 Alcan published his first book, *Psychanalyse des psychonévroses et des troubles de la sexualité* (Psychoanalysis of the Psychoneuroses and Sexual Disorders), but he mainly made a name for himself at the tenth Conference of French-speaking Psychoanalysts in February 1938 with his report on *Le masochisme, étude historique, clinique, psychogénétique, prophylactique et thérapeutique* (Masochism, an historical, clinical, psychogenetic, prophylactic and therapeutic study). Challenging the notion of a death instinct, he stressed the aggressive instinct, one of its manifestations being fear, masochism representing an eroticized turning of this against the self. In 1935 he married Louise Lydie Farman and their son Marc was born the following year. They divorced in 1950 and in 1952 he married Edmée Tedesco-Chemla. Their witnesses, one year before the split in the SPP, were Jacques Lacan and Sylvia Bataille.



During World War II he joined the Resistance as “agent P1” in the Brick network of the Fighting French Forces from November 1, 1942 to September 30, 1944. He was arrested in 1943 while trying to make his way to London. He narrowly escaped deportation thanks to his wife, who used a false baptism certificate to conceal his activities and his origins from the Germans. He was continually harassed by the Militia and went into hiding at Gassin (in the Var department). After the Liberation he resumed his activities as a captain and psychiatrist before being demobilized.

It was at this time that he began to do training analyses with such figures as Serge Lebovici and Salem Shentoub. He also inaugurated the shortening of sessions to forty-five minutes. In 1947 he succeeded John Leuba as president of the SPP and proved to be particularly active in this role. Along with his friend Jacques Lacan he was one of the two reporters at the eleventh Conference of French-speaking Psychoanalysts, held in Brussels in May 1947, where he presented a paper on *Les manifestations cliniques de l'agressivité et leur rôle dans le traitement psychanalytique* (Clinical Manifestations of Aggression and their Role in Psychoanalytic Treatment). In 1956 he presented, along with Serge Lebovici, *Les indications et contre-indications de cure psychanalytique* (Indications and Counter Indications of the Psychoanalytic Cure); in 1955, with René Diatkine and Jean Favreau *Le Moi dans la relation perverse* (The Ego in Perverse Relations) and; in 1958, with Paul-Claude Racamier, *La théorie psychanalytique des délires* (The Psychoanalytic Theory of Delusions). At the first Congress of Psychosomatic Medicine in 1960 he demonstrated his constant interest in psychosomatic medicine in a report written with René Held: *Maladies ou malade psychosomatique?* (Psychosomatic Illness or Patient?).

His staunch support for the training criteria laid down by the International Psychoanalytic Association—he was vice-president of the Association from 1957 to 1969—led him, on the occasion of the foundation of the Paris Institute of Psychoanalysis, to adopt a radical position in favor of a more rigorous, medical-style teaching. In this he found himself opposed to Daniel Lagache and Jacques Lacan. This opposition resulted in a definitive break in relations when the split took place on June 16, 1953. In 1951 he was appointed director of the institute, which was inaugurated on June 1, 1954, and ruled it with an iron fist until the revolt of the full members resulted in Serge Lebovici

being elected to his position in 1962. There is no doubt that the serious riding accident that plunged him into a coma in 1956 and left him with an embarrassing diplopia also modified his character and limited his activity. During his directorship he nevertheless created the Diagnostics and Treatment Center in 1954 and the Advanced Training Seminar in 1958.

It was essentially at these annual Seminars that Sacha Nacht continued his teaching activity and his activities within the SPP, refusing all other positions from this point onward. As a testimony to his services he was awarded as a parting gift the title of “director-founder in charge of relations with psychoanalysts in the provinces and abroad.” His influence over the general public began to wane before the rising star of the man who became his main adversary, Jacques Lacan.

We can see the beginning of his decline in the relative failure of the collection “*La psychanalyse d'aujourd'hui*” (Psychoanalysis Today)—the eponymous volume, published in 1957, which gave a fairly exhaustive outline of the conception of psychoanalysis that was behind it, followed by the equal relative failure of the *Traité de psychanalyse* (Treatise on Psychoanalysis), which was a personal project that he had earlier discussed with Ernest Jones (in a letter dated April 24, 1938, in which Nacht insisted “above all [on] the ‘didactic’ character I would like to see it have”). Only the first volume of *Traité* appeared in 1964. Although suffering from cancer, he nevertheless continued until the end in the considerable practice that his therapeutic reputation had won him.

In addition to his institutional work, and the mark it left on the French psychoanalytic movement for several decades, it is important to stress the no less negligible influence of his theoretical stances. For nearly thirty years they were a fairly constant if not a mandatory reference for the leading members of the SPP, almost all of whom had spent some length of time on his couch.

He was nevertheless a clinician rather than a theorist, his influence being manifested in the sphere of psychoanalytic practice, as he commented on it to his listeners at his famous Technical Seminar. He also outlined it in the books that documented his many, religiously attended contributions at the SPP symposia, among them *La Présence du psychanalyste* (The Presence of the Psychoanalyst; 1963), *Guérir avec Freud* (Healing with Freud; 1971). His comments on “non-verbal communication” were in response to

Lacan's assertions, as was his assertion that the psychoanalyst acts more "through what he is than through what he says." Nacht also stressed the distinction to be made between "transference reactions" and "transference neurosis," just as he stressed, in relation to the counter-transference, the necessary "goodness" of the psychoanalyst, as manifested in his/her "presence," ideas that are quite close to Sándor Ferenczi's position on tact. He even went so far as to advocate silence as a factor of vital integration, maintaining that words separate just as much as they lift the repression.

Little by little, although he had stressed the Freudian notion of "conflict" and the "cycle of frustration-aggression-fear" as opposed to the "autonomous Ego," repeating that "the energy sources of the Ego always derive from the aggressive and sexual instincts," toward the end of his life he nevertheless drew closer to the Ego-Psychology of his former analysts, declaring this publicly on the occasion of Rudolph Loewenstein's last visit to France in 1967.

Though not devoid of a sense of humor, Sacha Nacht affected a brusque manner and was often criticized for his authoritarianism, which earned him the nickname "satrap." And although his work is not much read today, he nevertheless remains an important figure for psychoanalysis in France, both for the institutional role he played and for the influence that his theoretical and technical conceptions exercised over the psychoanalysts of the Paris Psychoanalytic Society for some thirty years.

ALAIN DE MIJOLLA

*See also:* Centre de consultations et de traitements psychanalytiques Jean-Favreau; Congrès des psychanalystes de langue française des pays romans; Cure; Death instinct (Thanatos); France; Indications and contraindications for psychoanalysis in an adult; Lay analysis; Loewenstein, Rudolph M.; Neutrality/benevolent neutrality; Termination; Second World War: The effect on the development of psychoanalysis; Société psychanalytique de Paris et Institut de psychanalyse de Paris; Splits in psychoanalysis; Tact; Training analysis.

### **Bibliography**

Mijolla, Alain de. (2001). Splits in the French psychoanalytic movement between 1953 and 1964. In R. Steiner and J. Johns (Eds.), *Within Time and Beyond Time, A festschrift for Pearl King* (pp. 1–24). London: Karnac. (Original work published 1995)

Nacht, Sacha. (1938). *Le Masochisme. Étude historique, clinique, psychogénétique et thérapeutique*. Paris, Denoël.

———. (1950). *De la pratique à la théorie psychanalytique*. Paris, Presses Universitaires de France.

———. (1963). *La Présence du psychanalyste*. Paris, Presses Universitaires de France.

———. (1971). *Guérir avec Freud*. Paris, Presses Universitaires de France.

Saada, Denise. (1972). *Sacha Nacht*. Paris, Payot.

---

## **NAKEDNESS, DREAM OF**

Considered a "typical dream" by Freud, the dream of nakedness fulfills an exhibitionistic wish.

In a letter to Wilhelm Fliess dated May 31, 1897, Freud related one of his dreams: Wearing very few clothes, he was going up a staircase; upon encountering a woman, he felt "glued to the spot . . . paralyzed" (Letter 64, p. 254). He returned to this dream and analyzed it in *The Interpretation of Dreams* (1900a), in the paragraph he devoted to "typical dreams," that is, dreams that are more or less identical in everyone.

Freud emphasized three characteristics of the dream of nakedness: shame at being naked, indifference on the part of the spectators (usually numerous), and the sense of being paralyzed. He interpreted it as an oneiric fulfillment of an exhibitionistic wish dating back to the happy period of early childhood, when such a wish could legitimately be satisfied. Sándor Ferenczi, with the same interpretation, related several dreams of nakedness that enabled the dreamer to express their "undying longing for the return of the paradise of childhood" (1909/1952, p.106); elsewhere, however, he mentioned the dream of a woman who, after some hesitation, bathes nude in the presence of her son and uses it as a "means of inspiring terror" (1919, p. 329).

Dreams of nakedness, always linked to an erotic or exhibitionistic theme, are universal, and accordingly should be considered "typical dreams," as Freud proposed. Despite their commonality, however, they have not yet led to a specific theorization.

ROGER PERRON

See also: Dream; Exhibitionism; Look, gaze; Modesty; Voyeurism.

### **Bibliography**

Ferenczi, Sandór. (1950). Nakedness as a means for inspiring terror. In *Further Contributions to the Theory and Technique of Psycho-Analysis* (pp. 329–31; Jane Isabel Suttie, et al, Trans.). London: The Hogarth Press. (Original work published 1919)

———. (1952). The psychological analysis of dreams. In *First Contributions to Psycho-Analysis* (pp. 94–131; Ernest Jones, Trans.). London: The Hogarth Press. (Original work published 1909)

Freud, Sigmund. (1900a). The interpretation of dreams. Part 1, *SE*, 4: 1–338; Part 2, *SE*, 5: 339–625.

———. (1950a [1887–1902]). Extracts from the Fliess papers. *SE*, 1: 173–280.

Saul, Leon J. (1966). Embarrassment dreams of nakedness. *International Journal of Psycho-Analysis*, 47 (4), 552–58.

### **Further Reading**

Myers, Wayne A. (1989). The traumatic element in the typical dream of feeling embarrassed at being naked. *Journal of the American Psychoanalytic Association*, 37, 117–130.

---

## **NAME-OF-THE-FATHER**

Jacques Lacan introduced the notion of the “Name-of-the-Father.” By it he meant that every signifier, by its connection, not to an object, but rather to another signifier (Ferdinand de Saussure), symbolizes the lack that it introduces into being. As the particular symbolizer produces this effect while at the same time transforming it, the Name-of-the-Father enables human beings to tolerate and maintain desire. Without it, lack is experienced as a devouring force (cf. the case of Little Hans, Freud, 1909b) or a sucking force, the representation of a wound in the maternal body that is the source of a debt that can never be repaid.

The child discovers this name as a metaphor for the enigmatic object desired by the mother in the body of the child’s father. Thus, the child can find his way to one of two ways of assuming for this phallus; he can either have it like the father, or be it, in order to be desired.

The Oedipus complex makes the father the agent of the prohibition that makes it the impossible to access the object-cause-of-desire. Lacan’s structural analysis shows that the father is not himself the guarantor of the symbolic law, but is the one who authorizes desire. “[T]he true function of the Father . . . is fundamentally to unite (and not to oppose) a desire to the Law,” he wrote in “Subversion of the Subject and Dialectic of Desire” (Lacan, p. 309).

In the Other, the phallus thus no longer symbolizes a devouring agency, but instead one that rejoices if the subject experiences sexual enjoyment (*jouissance*) and procreates. Only one father can take on such a function, to the point of identifying with the phallus as symbolized by the dead Father.

It is understandable that some religions hold non-procreative sexual enjoyment (*jouissance*) to be sacrilegious, thus defrauding the phallic symbol by defying or abusing the dead Father. Religion’s traditional function is to affirm the primacy of sexual enjoyment against the destructive, abnormal forms of enjoyment that are in fashion.

CHARLES MELMAN

See also: Fatherhood; Foreclosure; Imaginary identification/symbolic identification; Infantile psychosis; Metaphor; Metonymy; Myth of origins; Parade of signifiers; Phobias in children; Psychoses, chronic and delusional; Real, the (Lacan); Real, Symbolic, and Imaginary father; Repudiation; Schizophrenia; Seminar, Lacan’s; Signifier; Signifier/signified; Signifying chain; Superego; Symptom/sinthome.

### **Bibliography**

Lacan, Jacques. (2002). The subversion of the subject and the dialectic of desire in the Freudian subconscious. In *Écrits: A selection* (Bruce Fink, Trans.). New York: Norton.

---

## **NARCISSISM**

The term *narcissism*, in keeping with the Greek myth of Narcissus, refers to self-love. The concept was introduced in Freud’s work shortly before the publication of “On Narcissism: An Introduction” (1914c). This paper was a response to four related issues: the difficulties encountered in psychoanalysis in working with

neurotics; the controversy with Jung, who defended the idea of the unity of psychic energy; the debate with Adler over the role of “masculine protest” in symptom-formation; and above all Freud’s growing interest in the psychoses, which opened his way to the study of the ego (1923a).

By proposing the notion of narcissism, Freud (1914c) meant to show how four different phenomena were related: narcissism as sexual perversion; narcissism as a stage in development; narcissism as libidinal cathexis of the ego; and narcissism as object-choice. He also described an ego-ideal as the heir of infantile narcissism and as a psychic agency of self-observation. These last two concepts would be elaborated on later by Freud.

The term was borrowed from Paul Näcke, who in 1899 described a form of behavior, resembling a perversion, whereby an individual treated his own body as one might treat the body of a sexual partner. In 1910 the word appeared in Freud’s writing for the first time in a long note added to the third edition of *Three Essays on the Theory of Sexuality* (1905c, p. 145n). He used it again in *Leonardo da Vinci and a Memory of his Childhood* (1910c), then offered a more complete account in his discussion of the case of Schreber: “There comes a time in the development of the individual at which he unifies his sexual instincts (which have hitherto been engaged in autoerotic activities) in order to obtain a love-object; and he begins by taking himself, his own body as his love-object” (1911c, p. 60). In the third chapter of *Totem and Taboo*, “Animism, Magic and the Omnipotence of Thoughts,” Freud defined narcissism in much the same way (1912–13a, p. 89).

At this time he formed the hypothesis of a narcissistic stage of development occurring between the autoerotic stage and the stage of object-love. In “Instincts and their Vicissitudes” (1915c), Freud described “a primal psychical situation”: “Originally, at the very beginning of mental life, the ego is cathected with instincts and is to some extent capable of satisfying them on itself. We call this condition ‘narcissism’ and this way of obtaining satisfaction ‘auto-erotic’” (p. 134). On its face, this account would seem to conflict with the one set forth in “On Narcissism” (1914c). But it becomes easier to see how narcissism can be viewed as a phase between autoeroticism and object love, and autoeroticism as a mode of satisfaction, if we bear in mind that the significance of autoeroticism changes

during development, as the identificatory processes described by Karl Abraham (incorporation) and by Sándor Ferenczi (introjection) come into play. Freud described the relationship between narcissistic identification and hysterical identification in the twenty-sixth of his *Introductory Lectures* (1916–1917a [1915–1916], pp. 427–428).

Freud postulated an original cathexis of the ego, a primary narcissism, in the infant; later some part of this libidinal cathexis would be redirected onto objects, creating an opposition between ego-libido and object-libido. Narcissism was thus seen as the libidinal complement to the egoism of the self-preservative instinct. It therefore played a part in the structural definition of the ego, for the ego retained a permanent narcissistic cathexis that no instinctual vicissitude could exhaust (1917a). In 1915 Freud had added a section on “The Libido Theory” to part 3 of the *Three Essays* (1905d), in which narcissistic libido was described as “the great reservoir from which object-cathexes are sent out and into which they are withdrawn once more” (1905d, p. 218). This metaphor recurred almost every time Freud discussed narcissism thereafter: in *Beyond the Pleasure Principle* (1920g), in the encyclopedia article “The Libido Theory” (1923a), and in *The Ego and the Id* (1923b). The narcissistic phase of libido fixation was also illustrated by the metaphor of an amoeba capable of putting forth extensions or pseudopodia that can in due course be withdrawn once more, this primitive distribution of the libido being reestablished during sleep. This analogy, first used by Freud in “On Narcissism” (1914c, p. 75), was repeated frequently between *Beyond the Pleasure Principle* (1920g) and *An Outline of Psychoanalysis* (1940a [1938]). The editors of the *Standard Edition* review Freud’s use of these two metaphors in an appendix to *The Ego and the Id* (1923b, pp. 63–66).

Freud contrasted the paths leading to object-choice of the narcissistic type with object-choice of the anaclitic or attachment type. In the case of narcissistic object-choice, a person loved “(a) what he himself is (i.e., himself), (b) what he himself was, (c) what he himself would like to be, (d) someone who was once part of himself.” In anaclitic object-choice, a person loved “the woman who feeds” or “the man who protects” (1914c, p. 90).

Freud presented an instance of narcissistic object-choice in his “Wolf Man” case history. There he inter-

preted a shift of object-choice by little Sergei (the future “Wolf Man”) from his nurse, or “Nanya,” to his father (1918b [1914], p. 27). This shift was precipitated by what he felt was a rejection by the nurse, which thus offered him the opportunity to “renew his first and most primitive object-choice”—that of his father—“which, in conformity with a small child’s narcissism, had taken place along the path of identification” (p. 27). Freud revisited this mode of identification in *The Ego and the Id*, where he distinguished it from the initial object-cathexis of the mother’s breast (1923b, p. 31).

In his paper on “The ‘Uncanny,’” Freud argued that “the double,” as studied by Otto Rank, had its origins in the period of primary narcissism, when it was invented on the basis of “unbounded self-love” as “an assurance of immortality”; only later would it become a “harbinger of death” (1919h, p. 235).

In the adult, infantile narcissism was replaced in Freud’s view by the ego-ideal. It was in “On Narcissism” (1914c, pp. 94–95) that he first discussed a specific psychic agency responsible for measuring the actual ego against an *ideal ego* or *ego ideal* (Freud himself never clearly distinguished between the two terms). This “critically observing agency” was involved, according to Freud, in so-called normal consciousness, in dream censorship, and in delusions of being watched (1914c, pp. 95–98). In “Mourning and Melancholia,” Freud assigned it a leading role in the onset of pathological states of mourning, pointing out that the ego ideal splits off from the rest of the ego (1916–17g [1915], pp. 247–48). He reiterated the idea of a splitting-off of the ego ideal in *Group Psychology and the Analysis of the Ego* (1921c). When the superego made its first appearance in Freud’s work (1923b, p. 28), it was an alternative name for the ego ideal; later, it would operate principally as an agency of guarding and prohibiting. In his later work Freud referred to the ego ideal only intermittently, using it in a quasi-technical way. In the *New Introductory Lectures on Psycho-Analysis*, the superego was described as “the vehicle of the ego ideal by which the ego measures itself” (1933a [1932], pp. 64–65 and n.).

Freud’s contemporaries clarified the change in his thinking represented by the introduction of narcissism. Sándor Ferenczi remarked in “Introjection and Transference” (1909) that the newborn experienced everything in a monistic way. The desire to rid itself of unpleasant affects led the child to exclude objects from

the mass of its perceptions. The infant invented the outside world and then opposed its ego to it by means of a primitive projection that thus established dualism—a point of view that Melanie Klein did not take into account later when she posited the existence of a dualism from the beginning. Ferenczi first used the term *narcissism* in 1913.

The earliest contributions of Karl Abraham, between 1913 and 1920, show that it was the difficulties he encountered in the treatment of neurotics that prompted him to consider the role of narcissism. In “A Short Study of the Development of the Libido, Viewed in the Light of Mental Disorders” (1924), however, he based himself on the study of the psychoses, and especially of melancholia, to connect narcissism with the specific quality of thought needed to transform a fantasy into a delusional idea. The symptomatology of melancholia further led him to consider overestimation and underestimation as expressions, respectively, of positive and negative narcissism related to self-love and self-hatred.

In his article “On the Origin of the ‘Influencing Machine’ in Schizophrenia” (1919), Victor Tausk argued that the libido, at the beginnings of mental life, corresponded to an “objectless” period (p. 47). The formation of the ego was thus associated with the discovery of the object and corresponded to the development of the sense of reality. Tausk posited the existence of a psychic narcissism that renewed itself “with each new acquisition of the ego,” contrasting it with an “organic narcissism that guarantees in the unconscious the unity and functioning of the organism” (p. 56). Lou Andreas-Salomé, for her part, identified narcissism with pregenital sexuality, as distinct from object-love, which implied a partner. She looked upon narcissism as a borderline concept with a twofold orientation, referring on the one hand to a reservoir for all the manifestations of the psyche and on the other to the location of all tendencies to regression to pathological childhood fixations. For Andreas-Salomé, narcissism defined physical being, unifying internal and external processes.

Several later authors contributed significantly to the discussion of narcissism. Although there was no place in Melanie Klein’s theory for autoeroticism or narcissism, her descriptions of infantile omnipotence and megalomania provided important insights for the clinical understanding of narcissistic states. In 1963, writing on the psychopathology of narcissism, Herbert

Rosenfeld (1965) was especially concerned to arrive at a better definition of object-relationships and their attendant defense mechanisms in narcissism. The study of therapeutic factors led him later to analyze the influence of narcissism on the work of the psychoanalyst. He drew attention to the existence, alongside the libidinal aspect of narcissism, of a destructive narcissism related to the death instinct.

Heinz Kohut offered his own reformulation of narcissism, describing it as the cathexis of self-representations (and not of the ego); he defined it as an agency of the personality responsible for issues of relationship. His clinical study “The Two Analyses of Mr. Z” (1979) reflected the transition from ego-psychology to the self-psychology that he developed out of it. These ideas were outlined in Kohut’s *The Analysis of the Self* (1971). Kohut might be criticized for presenting his very rich contribution to the field as an alternative to classical analysis, but his observations show the benefits of a way of listening, clearly within the Freudian tradition, that combines attention to narcissism with attention to object-cathexes.

D. W. Winnicott made no direct reference to narcissism. His account of the self differed greatly from Kohut’s. The articles published in *Collected Papers: Through Paediatrics to Psychoanalysis* (1958) and in *The Maturational Processes and the Facilitating Environment* (1965) contain everything he wrote on the subject. His brilliant observations of the mother-child couple nevertheless throw considerable light on primary narcissism, which in the young child can be viewed as the extension of the mother’s narcissism. In contrast to the metaphor of the mirror in which Narcissus recognized himself and was lost, Winnicott offered his own vision of a child destined to find itself and live, the mirror in this case being the mother’s face: “What does the baby see when he or she looks at the mother’s face? I am suggesting that, ordinarily, what the baby sees is himself or herself. In other words the mother is looking at the baby and *what she looks like is related to what she sees there*” (1967, p. 131). It is worth pointing out the importance in this view of the environment and of emotional experience.

Since Freud, in France, there has been a particularly lively interest in the question of narcissism. The mirror stage, as described by Jacques Lacan, originated in the work of the psychologist Henri Wallon. Unlike Winnicott, for whom the child’s environment was supportive, Lacan (1949) saw it rather in terms of

“constraints,” and contrasted it sharply with the eighteen-month-old’s “jubilant assumption of his specular image.” According to Lacan, “It suffices to understand the mirror stage... *as an identification*” (2002, p. 4). The knowledge of the ego that Lacan proposed here amounted to the suggestion that we consider rather the “misrecognition” characteristic of the ego.

Harking back to Lou Andreas-Salomé, Béla Grunberger drew attention to a double orientation of narcissism—as both a need for self-affirmation and a tendency to restore permanent dependency. The active presence of narcissism throughout life led Grunberger to suggest treating it as an autonomous factor (1971). He even mooted the idea of promoting it to the status of a psychic agency.

Under the evocative title *Life Narcissism, Death Narcissism* (1983), André Green clarified the conflict surrounding the object of narcissism (whether a fantasy object or a real object) in its relationship to the ego. For Green, it was because narcissism affords the ego a certain degree of independence by transferring the desire of the Other to the desire of the One that a lethal kind of narcissism must be considered, for the object is destroyed at the beginning of this process. Rather than unpleasure, it is the “neutral” that replaces pleasure in Green’s account. In this connection Freud had proposed the metaphor of the return to the inanimate. By analogy with Freud’s analysis of masochism, which distinguished between erogenous masochism, female masochism, and moral masochism, Green evokes physical narcissism, intellectual narcissism, and moral narcissism, without suggesting any analogy between these terms.

A broad range of studies exists on Freud’s “On Narcissism,” as may be seen from the inventory in a monograph published under the auspices of the International Psychoanalytical Association (Sandler et al., 1991).

MICHEL VINCENT

*See also:* Absence; Action-thought (H. Kohut); Adolescent crisis; Agency; Alter ego; Analyzability; Andreas-Salomé, Louise (Lou); Animus-Anima (analytical psychology); Antinarcissism; Autoeroticism; Bipolar self; Borderline conditions; Castration complex; *Character Analysis*; Narcissistic injury; Character formation; Character neurosis; Double, the; *Ego and the Id, The*; Ego

ideal; Ego ideal/ideal ego; Ego-instinct; Ego-libido/object-libido; Erotogenicity; Erotogenic zone; Femininity; Fetishism; Free energy/bound energy; Grandiose self; Heroic self; Homosexuality; Humor; Idealization; Idealized parental imago; Idealizing transference; Identification; Identity; Infantile omnipotence; Libido; Life instinct (Eros); Magical thinking; Megalomania; Mirror transference; Monism; Narcissism of minor differences; Narcissism, primary; Narcissism, secondary; Narcissistic defenses; Narcissistic elation; Narcissistic rage; Narcissistic transference; Narcissistic withdrawal; Object; Object, change of/choice of; Omnipotence of thought; "On Narcissism: An Introduction"; "On the Origin of the 'Influencing Machine' in Schizophrenia"; Optical schema; Paradox; Self esteem; Self; Self-object; Self psychology; *Self, The*; Somatic compliance; State of being in love; Sublimation; Transference of creativity; Trauma; Twinship transference/alter ego transference; Violence, instinct of; Wish for a baby.

### Bibliography

- Abraham, Karl. (1924). A short history of the development of the libido, viewed in the light of mental disorders. In *Selected papers of Karl Abraham, M.D.* (Douglas Bryan and Alix Strachey, Trans.). London: Hogarth Press, 1927.
- Andreas-Salomé, Lou. (1962 [1921]). The dual orientation of narcissism. *Psychoanalytic Quarterly*, 31.
- Ferenczi, Sándor. (1909). Introjection and transference. In *First contributions to psycho-analysis*. London: Hogarth Press, 1952 [1916].
- . (1913). Stages in the development of the sense of reality. In *First contributions to psycho-analysis*. London: Hogarth Press, 1952 [1916].
- Freud, Sigmund. (1905d). Three essays on the theory of sexuality. *SE*, 7: 123–243.
- . (1910c). Leonardo da Vinci and a memory of his childhood. *SE*, 11: 63–137.
- . (1911c). Psycho-analytic notes on an autobiographical account of a case of paranoia (dementia paranoides). *SE*, 12: 9–79.
- . (1912–13a). Totem and taboo. *SE*, 13: 1–161.
- . (1914c). On narcissism: An introduction. *SE*, 14: 67–102.
- . (1915c). Instincts and their vicissitudes. *SE*, 14: 109–140.
- . (1916–17a [1915–16]). Introductory lectures on psycho-analysis. *SE*, 15–16.
- . (1917a). A difficulty in the path of psycho-analysis. *SE*, 17: 135–144.
- . 1918b [1914]. From the history of an infantile neurosis. *SE*, 17: 1–122.
- . (1919h). The "uncanny." *SE*, 17: 217–256.
- . (1920g). Beyond the pleasure principle. *SE*, 18: 1–64.
- . (1921c). Group psychology and the analysis of the ego. *SE*, 18: 65–143.
- . (1923a). Two encyclopaedia articles. *SE*, 18: 255–259.
- . (1923b). The ego and the id. *SE*, 19: 1–66.
- . (1933a [1932]). New introductory lectures on psycho-analysis. *SE*, 22: 1–182.
- . (1940a). An outline of psycho-analysis. *SE*, 23: 139–207.
- Freud, Sigmund, and Andréas-Salomé, Lou. (1972). *Letters* (Ernst Pfeiffer, Ed.; William and Elaine Robson-Scott, Trans.). New York: Harcourt Brace.
- Green, André. (1983). *Life narcissism, death narcissism* (Andrew Weller, Trans.). London and New York: Free Association Books, 2001.
- Grunberger, Béla. (1971). *Le narcissisme. Essais de psychanalyse*. Paris: Payot.
- Kohut, Heinz. (1971). *The analysis of the self: A systematic approach to the psychoanalytic treatment of narcissistic personality disorders*. New York: International Universities Press.
- . (1979). The two analyses of Mr Z. *International Journal of Psycho-Analysis*, 60, 1.
- Lacan, Jacques. (2002). The mirror stage as formative of the I function, as revealed in psychoanalytic experience. In *Écrits: A Selection* (Bruce Fink, Trans.). New York: Norton. (Original work published 1949)
- Oppenheimer, Agnès. (1996). *Kohut et la psychologie du self*. Paris: Presses Universitaires de France.
- Rosenfeld, Herbert. (1965). *Psychotic states: A psychoanalytic approach*. London: Hogarth Press.
- Sandler, J. et al. (1991). *Freud's "On Narcissism: An Introduction"*. New Haven, CT, and London: Yale University Press.
- Tausk, Victor. (1947). On the origin of the "influencing machine" in schizophrenia. In Robert Fliess (Ed.), *The Psycho-Analytic Reader*. New York: International Universities Press. (Original work published 1919)
- Winnicott, Donald W. (1958). *Collected papers: Through paediatrics to psychoanalysis*. London: Tavistock.

———. (1965). *The maturational processes and the facilitating environment*. London: Hogarth Press/Institute of Psycho-Analysis.

———. (1967). Mirror-role of mother and family in child development. In *Playing and reality*. Harmondsworth: Penguin, 1974.

## NARCISSISM OF MINOR DIFFERENCES

In his article on “The Taboo of Virginity” (1918a) and on the subject of man’s “narcissistic rejection” of woman because of his castration complex, Freud isolated for the first time a particular reaction that he later saw as the driving force behind racism. He wrote “the practice of taboos we have described testifies to the existence of a force which opposes love by rejecting women as strange and hostile. Crawley, in language which differs only slightly from the current terminology of psychoanalysis, declares that each individual is separated from the others by a ‘taboo of personal isolation,’ and that it is precisely the minor differences in people who are otherwise alike that form the basis of feelings of strangeness and hostility between them. It would be tempting to pursue this idea and to derive from this ‘narcissism of minor differences’ the hostility which in every human relation we see fighting successfully against feelings of fellowship and overpowering the commandment that all men should love one another” (p. 199).

He returned to this idea without naming it in *Group Psychology and the Analysis of the Ego* (1921c) when discussing hostile sentiments with regard to whatever is strange: “In the undisguised antipathies and aversions which people feel towards strangers with whom they have to do we may recognize the expression of self-love—of narcissism. This self-love works for the preservation of the individual, and behaves as though the occurrence of any divergence from his own particular lines of development involved a criticism of them and a demand for their alteration. We do not know why such sensitiveness should have been directed to just these details of differentiation” (p. 102).

Not until *Civilization and its Discontents* did Freud give the notion the full meaning that it has today: “It is always possible to bind together a considerable number of people in love, so long as there are other people left over to receive the manifestations of their aggres-

siveness. I once discussed the phenomenon that it is precisely communities with adjoining territories, and related to each other in other ways as well, who are engaged in constant feuds and in ridiculing each other—Germans and South Germans, the English and the Scotch, and so on. I gave this phenomenon the name of ‘the narcissism of minor differences,’ a name which does not do much to explain it. We can now see that it is a convenient and relatively harmless satisfaction of the inclination to aggression, by means of which cohesion between the members of the community is made easier. In this respect the Jewish people, scattered everywhere, have rendered most useful services to the civilizations of the countries that have been their hosts” (1930a [1929], p. 114).

After Freud the notion entered psychoanalytic discourse without much further study. Otto Fenichel described it as a stumbling block in identification with the other that is destined to surpass hostile sentiments (1934). The idea is mentioned in other papers to illustrate incomprehension between adults and adolescents or disagreements between psychoanalysts despite their belonging to the same group. Glen O. Gabbard in *On Hate in Love Relationships: The Narcissism of Minor Differences Revisited* presented the most thorough study of it. Gabbard stresses the experience of disappointment when, in spite of the aspiration for similarity, we find differences in the loved object, and he links this disappointment to preoedipal and oedipal experiences that punctuate the processes of separation and autonomy.

With the exception of this last work, the notion has been used essentially to explain the hate relations that develop between humans or groups of humans that, by all appearances, have much in common.

ALAIN DE MIJOLLA

See also: Civilization (Kultur); Narcissism; Racism, anti-Semitism and psychoanalysis.

### Bibliography

- Fenichel, Otto. (1934). *Outline of clinical psychoanalysis*. New York: W. W. Norton.
- Freud, Sigmund. (1918a). The taboo of virginity. *SE*, 11: 191–208.
- . (1921c). Group psychology and the analysis of the ego. *SE*, 18: 65–143.



———. (1930a [1929]). Civilization and its discontents. *SE*, 21: 57–145.

Gabbard, Glen O. (1993). On hate in love relationships: The narcissism of minor differences revisited. *Psychoanalytic Quarterly*, 62, 229–238.

### Further Reading

Volkan, Vamik D. (1986). The narcissism of minor differences between opposing nations. *Psychoanalytical Inquiry*, 6, 175–192.

---

## NARCISSISM, PRIMARY

Primary narcissism corresponds to the original libidinal cathexis of the ego. Later, part of that cathexis will be redirected onto objects, giving rise to the opposition between ego-libido and object-libido.

It is worth noting that Freud often spoke as often of “original narcissism” as of “primary narcissism”—the sense is the same.

In the second part of “On Narcissism: An Introduction” (1914c), Freud offered an ex post facto explanation of the nature of narcissism based on the tender attitude of parents towards their children, an attitude that embodies a “revival and reproduction of their own narcissism, which they have long since abandoned” (p. 91). As a result parents attribute every conceivable perfection to their young children.

The disturbances to which primary narcissism is prone are what allow its existence to be inferred. Among them are the effects of the castration complex, described by Freud at the beginning of the third part of “On Narcissism” as anxiety in boys about the penis and envy of the penis in the case of girls (p. 92). In opposition to Adler’s theory of masculine protest, Freud defended a psychology of repression, arguing that a precondition of repression was the establishment of an ideal, and that such an ideal was instituted during the development of the ego. As it evolved, the ego distanced itself from primary narcissism, formed an ego-ideal, and proceeded to cathect objects.

Primary narcissism is the narcissism of the suckling. Serge Lebovici (1997) points up the coextensive nature of primary narcissism and the individual’s sense of his or her own continuity. Failures of primary narcissism are responsible, in Lebovici’s view, for

precipitating the fantasy of the primal scene, and hence for feelings of being the third party. The state of primary narcissism is clearly compatible with the infant’s absence of any sense of its need for help, so well described by Freud in a note added in 1912 to his paper “Formulations on the Two Principles of Mental Functioning” (1911b). This theorization is particularly useful in understanding depression brought on by de-idealization.

MICHEL VINCENT

*See also:* Basic fault; Ego-libido/object-libido; Hungarian School; *Metapsychological Supplement to the Theory of Dreams*; Monism; Narcissism; Narcissistic defenses; Narcissism, secondary; Oceanic feeling; Optical schema; Organization; Pictogram; Primal, the; Primary love; Schizophrenia; Silence; Symbiosis/symbiotic relation.

### Bibliography

Freud, Sigmund. (1911b). Formulations on the two principles of mental functioning. *SE*, 12: 213–226.

———. (1914c). On narcissism: An introduction. *SE*, 14: 67–102.

———. (1919h). The “uncanny.” *SE*, 17: 217–256.

Lebovici, Serge. (1997). Défense et illustration du concept de narcissisme primaire. Les avatars du narcissisme primaire et le processus de subjectification. *Psychiatrie de l'enfant*, 40, (2), 429–463.

---

## NARCISSISM, SECONDARY

Secondary narcissism corresponds to the return to the ego of the libido, withdrawn from objects. Freud described this for the first time (1914c) in relation to a state he called “paraphrenia,” which corresponded to the precocious dementia of Kraepelin or to the schizophrenia of Bleuler. Withdrawal of the libidinal investment in objects, followed by a re-investment in the ego, was considered responsible for two characteristic manifestations: lack of interest in the external world and delusions of grandeur.

Another approach to narcissism was indicated in the last section of “On Narcissism: An Introduction,” on the basis of original narcissism. The construction of an ego ideal played a central role in the psychology of

repression, conceived as a result of the conflict between instinctive drives and cultural representations. This is the narcissistic aspect of a structure of surveillance, of which Freud would complete the description in 1923, with *The Ego and the Id* (1923b). Freud in 1914 had moreover attributed the critical voices of the delusion of being watched, of paranoia, rising out of regression, to this surveillance mechanism.

Finally, the interpretation of Leonardo da Vinci's homosexuality (1910c) constituted the descriptive model of a process of identification by replacement of an object investment (the mother), and by the introjection of the qualities of this object (identification). This identification process was taken up again in "Mourning and Melancholia" (1917e), where Freud discussed narcissistic identification. He returned to it again in *Group Psychology and the Analysis of the Ego* (1921c) and finally in *The Ego and the Id* (1923b).

MICHEL VINCENT

*See also:* Narcissism, Narcissism, primary; Superego; Tics

### **Bibliography**

- Freud, Sigmund. (1910c). Leonardo da Vinci and a memory of his childhood. *SE*, 11: 57–137.
- . (1914c). On narcissism: An introduction. *SE*, 14: 67–102.
- . (1916–17g [1915]). Mourning and melancholia. *SE*, 14: 237–258.
- . (1921c). Group psychology and the analysis of the ego. *SE*, 18: 65–143.
- . (1923b). The ego and the id. *SE*, 19: 1–66.

## **NARCISSISTIC DEFENSES**

Narcissistic defenses are psychic procedures utilized by the ego, in the case where the latter is understood as the only (or almost only) object of investment by the libido. Their function is to protect the integrity and the psychic endurance of the ego.

Precise indications of specifically narcissistic defenses are not to be found in the works of Freud. However, the concept appeared in relation to a number of topics: infantile omnipotence, idealization of the love object, paranoid projection, counter invest-

ment in the external world, the depressed person's "narcissistic" identification, the hypochondriac's overinvestment in the organs of the body, regression in treatment, and regression in dreams.

Several authors, among them Viktor Tausk (1919/1933), Michael Balint (1935/1965), Paul Federn (1928), Francis Pasche (1965), Béla Grunberger (1975), and André Green (1983), have contributed to the study of narcissism. However, it has been particularly the analysis of the pathologies of narcissism, either by the members of the Kleinian school, or by representatives of the American schools (Otto Kernberg, Heinz Kohut), which have allowed a better delineation of narcissistic defensive processes, based on an analysis of the mechanisms of denial, separation, projective identification, and pathological idealization.

In discussing narcissistic defenses, both the Freudian distinction between primary and secondary narcissism, as well as that between the normal and the pathological, must be maintained. In effect, primary narcissism is first conceived by Freud as a state situated between autoeroticism and object love; following his second theory of the psychic apparatus, it is understood as an primal state wherein the child takes itself as a love object, even before the constitution of the first objective links, raising the question of whether a state of such psychic immaturity could raise "defenses" other than of a sensory-motor sort. Besides, as Freud demonstrated, the continuum between the normal and pathological has allowed the subject to be considered to be, in a certain measure, narcissistic.

ELSA SCHMID-KITSIKIS

*See also:* Defense; Megalomania; Narcissism; Narcissistic withdrawal.

### **Bibliography**

- Balint, Michael. (1965). *Critical notes on the theory of the pregenital organizations of the libido. Primary love and psycho-analytic technique*. New York: Liveright. (Original work published 1935)
- Bergeret, Jean. (1996). *La Pathologie narcissique*. Paris: Dunod.
- Federn, Paul. (1928). Narcissism in the structure of the ego. *International Journal of Psychoanalysis*, 9, 401–419.
- Freud, Sigmund. (1914c). On narcissism: An introduction. *SE*, 14: 67–102.

Green, André. (1983). *Life narcissism, death narcissism* (Andrew Weller, Trans.) London and New York: Free Association Books.

Grunberger, Béla. (1971). *Narcissism: Psychoanalytic essays* (Joyce S. Diamanti, Trans., foreword by Marion M. Oliner). New York: International Universities Press.

Kohut, Heinz. (1974). Remarks about the formation of the self. In *The search for the self* (Vol. 2). New York: International Universities Press: 737–770.

Pasche, Francis. (1965). L'anti-narcissisme. *Revue française de psychanalyse*, 29 (5–6), 503–518.

Tausk, Viktor. (1933). On the origin of the “influencing machine” in schizophrenia. In Robert Fliess (Ed.), *The psycho-analytic reader*. New York: International Universities Press. (Original work published 1919)

---

## NARCISSISTIC ELATION

The term *narcissistic elation* was coined by Béla Grunberger (1971/1979) to describe the state of prenatal beatitude, which according to him characterizes the life of the fetus: a state of megalomaniacal happiness amounting to a perfect homeostasis, devoid of needs or desires. The ideal here is bliss experienced in absolute withdrawal from the object and from the outside world. Narcissistic elation is at once the memory of this unique and privileged state of elation; a sense of well-being of completeness and omnipotence linked to that memory, and pride in having experienced this state, pride in its (illusory) oneness.

Narcissistic elation is characteristic of an object relationship that is played out, in its negative version, as a state of splendid isolation, and, in its positive version, as a desperate quest for fusion with the other, for a mirror-image relationship. It involves a return to paradise lost and all that is attached to this idea: fusion, self-love, megalomania, omnipotence, immortality, and invulnerability.

After birth, the infant continues to enjoy the proto-narcissistic existence as before, and this is reinforced by the fact that people around it, in particular the mother, meet all its needs and wishes. This state of illusion is soon compromised, however, as inevitable frustrations begin to occur. The traces of this state of elation and megalomania, based on the notions of harmony and omnipotence, nevertheless provide a source of psychic energy that will remain active

throughout life. The child, and later the adult, will seek to preserve and return to this narcissistic mode of being, notably through music, passionate love, or mystical ecstasy. Perhaps, after all, what fascinated Narcissus was the sight—beyond his own reflection—of the amniotic water, and the deep, regressive promise of happiness that it held out.

Following an initial period of elation known as the “honeymoon,” psychoanalytic treatment must succeed in bringing together the narcissistic elements of the self by integrating them into interpretations of reality: ego-libido and object-libido must arrive at a satisfactory compromise.

MARIE-FRANCE CASTARÈDE

See also: Ego-libido/object-libido; Narcissism.

## Bibliography

Grunberger, Béla. (1979). *Narcissism: Psychoanalytic essays*. New York: International Universities Press. (Original work published 1971)

---

## NARCISSISTIC INJURY

The concept of narcissistic injury does not appear as such in Freud. Since Freud, the theoretical elaboration of narcissism and the development of new entities of psychopathology (narcissistic personalities, borderline states) has led to the creation of this concept to describe the consequences, on the narcissistic level, of a trauma to the psychic apparatus arising from internal or external factors.

It should be remarked, however, that the introduction of the concept of narcissism (Freud, 1914c) prepared the way in metapsychology for the notion of narcissistic injury, if one also takes into account the Freudian propositions concerning the development of the ego in relation to the exigencies of the reality principle (Freud, 1911b), and his ideas about infantile helplessness (*Hilflosigkeit*). On the one hand, conflicting drives, and, on the other, the object and its vicissitudes inflict a series of traumas on narcissism, whereby the anguish linked to loss and/or separation becomes structural. Thereby, birth, weaning, anality, the castration complex, and the fear of death are all prototypical phenomena that give rise to narcissistic injuries.

Further reflection on narcissism, and the post-Freudian clinic, have led to theories in which the notion of narcissistic injury occupies a central place, as well as to developments and modifications in psychoanalytic technique. In the United States, the “Self Psychology” of Heinz Kohut and the description of borderline states and narcissistic personalities by Otto Kernberg have made this category central, allowing the evaluation of psychic organization and serving as transference-countertransference guide in the course of the analysis. Heinz Kohut particularly has stressed the significance of “narcissistic rage” as a reaction to narcissistic injury: faced with the failure of the self-object, narcissistic rage would be the aggressive result of shame.

In France, Béla Grunberger considered that narcissistic injury, inflicted on the ego by the vicissitudes of a disappointed ego-ideal, is an integral part of narcissism; accordingly, this theory made narcissistic injury a pivotal notion, since the impotence inherent in the human condition constitutes, in itself and from the outset, a narcissistic injury, one that is preponderant subsequently in the dialectic between narcissism and the drives, as well as being the source of ethics and civilization. André Green, stressing the role of the object, speaks of object trauma, whose very existence is the cause of injury, calling for never-completed reparation.

The notion of narcissistic injury is useful in accounting for the rapports between narcissism, the drives, and the object. However, as critics of Kohut point out, its excessively univocal development risks de-emphasizing sexuality.

PANOS ALOUPIS

*See also:* Castration complex; Disintegration products; Halberstadt-Freud, Sophie; Narcissistic rage; Paranoia; Transference depression.

### **Bibliography**

- Freud, Sigmund. (1914c). On narcissism: An introduction. *SE*, 14: 67–102.
- Green, André. (2001). *Life narcissism, death narcissism* (Andrew Weller, Trans.). London: Free Association Books. (Original work published 1983)
- Grunberger, Béla. (1989). *Narcisse et Anubis*. Paris: Des femmes.
- Kernberg, Otto F. (1975). *Borderline conditions and pathological narcissism*. New York: Jason Aronson.

Kohut, Heinz. (1972). Thoughts on narcissism and narcissistic rage. In *The search for the self* (Vol. 2, pp. 615–658). New York: International Universities Press.

## **NARCISSISTIC NEUROSIS**

Freud proposed the term *narcissistic neurosis* as a designation for manic-depressive psychosis insofar as it was characterized by the withdrawal of libido onto the ego. German psychiatric nosology subscribed to a clinical distinction between psychoses and neuroses, but at the end of the nineteenth century only the psychoses were clearly defined, while the neuroses were still a rather disparate category.

Little by little, in the drafts Freud included with his letters to Wilhelm Fliess (1950a) and in a series of articles (1894a, 1895b, 1895c, 1896a, 1896b) contemporary with the *Studies on Hysteria* (1895d), Freud adopted a distinction between the “actual neuroses,” related to somatic conditions, and the “psycho-neuroses” (or “neuro-psychoses”), related to mental conflicts. The Schreber case (1911c), in which homosexuality played an essential part, led him to point up the role of narcissism (1914c) in the etiology of illnesses like Schreber’s. The symptoms in such cases indicated a withdrawal of libido from objects in the outside world. This libido was then redirected onto the ego, causing delusions of grandeur.

Thereafter, Freud divided the psychoneuroses into transference psychoneuroses and narcissistic psychoneuroses, the latter corresponding to the psychoses. Only later, after the major theoretical revision occasioned by the introduction of the death instinct (1920g), and of a more radical description of the mental personality, now seen as made up of the id, the ego, and the superego (1923b), did it become possible for Freud to sum up the difference between neurosis and psychosis in a much simpler way: neurosis meant conflict between the ego and the id, while psychosis resulted from an analogous difficulty in the relationship between the ego and the external world.

While acknowledging that much remained unknown concerning the origin and role of the superego, his theory of repression led Freud to examine conflict between ego and id. Meanwhile he defined narcissistic neurosis as the outcome of a struggle between the ego and the superego. He stressed that melancholia was a

prime example. All pathologies arising from conflict between the ego and the superego were to be categorized as “narcissistic psychoneuroses.” The identification of this group of illnesses lying at the frontier between neuroses and psychoses cleared the way for much later discussions of borderline states, drug addiction, and for the sort of approach to psychosomatic illness promoted by the so-called Paris school.

Melancholia qualified as narcissistic psychoneurosis par excellence: a state where a “pure culture of the death instinct” supports a superego at war with the ego. “Complete and unrestricted cannibalism” is fueled by “unrestricted narcissism” (Abraham, 1924, p. 488): the melancholic is unaffected by the interests of the object, and the destruction of the incorporated object is pursued with no scruple. Such are the terms used by Karl Abraham, and there can be no doubt that Melanie Klein had them in mind later. At the same time Abraham evoked the useful idea of a more restrained narcissism, an impulse to partial incorporation that shows a degree of respect for the object—a picture demonstrating how variously having and being can be melded.

Francis Pasche (1965) sought to clarify the issue of depression by opposing an antinarcissism to narcissism, and grounding this polarity in the dualism of the life and death instincts. He called antinarcissism a “tendency whereby the subject renounces a part of himself” The idea suggested itself to him on the basis of a feeling reported by patients, for whom “the object is not formidable only because it is felt to be destructive and destructible element, but also because it can be experienced, by virtue of its very presence in the subject’s emotional world, as a thief of vital forces and a drainer of energy.”

Narcissism and antinarcissism, Pasche argued, were derivatives both of Eros and Thanatos. Clinical experience with psychoses invariably showed that psychotic alienation was experienced subjectively in terms of submission to an external will. Reconstruction of early mother-child relationships supported the conclusion that “the first cathexes would imply not only fusion and interpenetration, but also distinction and separation, with the resulting emergence, alongside the wish to reject and the wish to be absorbed, of a wish to confirm the object in some sense in its rightful place.” Hence, the infant who drinks the mother in with its eyes, or sets her on a pedestal and invests her with the authority that is her due.

Narcissism and antinarcissism constitute a dynamic structure, a permanent combination in which the instincts are deeply rooted.

MICHEL VINCENT

*See also:* Acute psychoses; Ego; Ego-libido/object-libido; Narcissism; Narcissistic transference; Neurosis; Psychosomatic.

### **Bibliography**

Abraham, Karl. (1924). A short history of the development of the libido, viewed in the light of mental disorders. In *Selected Papers of Karl Abraham, M.D.* (Douglas Bryan and Alix Strachey, Trans.) London: Hogarth. (Reprinted as *Selected Papers on Psycho-Analysis*. New York: Brunner/Mazel, 1979)

Freud, Sigmund. (1894a). The neuro-psychoses of defence. *SE*, 3: 41–61.

———. (1895b [1894]). On the grounds for detaching a particular syndrome from neurasthenia under the description “anxiety neurosis.” *SE*, 3: 85–115.

———. (1895c). Obsessions and phobias: Their psychological mechanism and their aetiology. *SE*, 3: 69–82.

———. (1896a). Heredity and the aetiology of the neuroses. *SE*, 3: 141–156.

———. (1896b). Further remarks on the neuro-psychoses of defence. *SE*, 3: 157–185.

———. (1911c). Psycho-analytic notes on an autobiographical account of a case of paranoia (dementia paranoides). *SE*, 12: 1–82.

———. (1914c). On narcissism: An introduction. *SE*, 14: 67–102.

———. (1920g). Beyond the pleasure principle. *SE*, 18: 1–64.

———. (1923b). The ego and the id. *SE*, 19: 1–66.

———. (1924b). Neurosis and psychosis. *SE*, 19: 147–153.

———. (1950a). Extracts from the Fliess papers. *SE*, 1: 173–280.

Pasche, Francis. (1965). L’anti-narcissisme. *Revue française de psychanalyse*, 29 (5–6), 503–518.

---

## **NARCISSISTIC RAGE**

A reaction to narcissistic injury in the context of narcissistic pathologies, narcissistic rage is to narcissism as aggression is to Oedipal desire.

As a descriptive term, *narcissistic rage* was first employed by Heinz Kohut and became a significant concept in psychoanalysis about 1972, with publication of his *The Analysis of the Self*. Derived from analyses of narcissistic personalities, the term also reflected Kohut's broader interests in literature, culture, and civilization.

Narcissistic rage can include phenomena as different as slight annoyance, paranoid rancor, and catatonic fury. Linked to loss of control, it signals the existence of some unresolved psychic injury of an archaic, narcissistic character. Such rage aims to repair an injustice, a narcissistic wound unrelieved so long as shame persists and the witness to it is not destroyed. Thus, the need for revenge in the face of ridicule, disdain or contempt, represents an expression of narcissistic rage. Destructiveness is linked to this kind of narcissistic defect, not a reaction to a primary instinct.

Aggression toward another person (or mental representation of one) should be distinguished from narcissistic rage directed at a *self-object*, Kohut's term for an archaic object that must not be experienced as a disappointing or failing. Although aggressivity ceases when the obstacle is lifted, narcissistic rage cannot be quelled.

As a descriptive term, the concept of narcissistic rage gained considerable acceptance in psychoanalysis. Kohut's broader view of narcissism as a separate line of development, however, though much discussed, won less support.

AGNÈS OPPENHEIMER

*See also:* Kohut, Heinz; Narcissistic injury.

### **Bibliography**

Kohut Heinz. (1971). *The analysis of the self: A systematic approach to the psychoanalytic treatment of narcissistic personality disorders*. New York: International Universities Press.

———. (1972). Thoughts on narcissism and narcissistic rage. In *The search for the self* (Volume 2: pp. 615–658). New York: International Universities Press.

### **Further Reading**

Ornstein, Anna, et al. (1998). The fate of narcissistic rage in psychotherapy. *Psychoanalytical Inquiry*, 18, 55–70.

## **NARCISSISTIC TRANSFERENCE**

*Narcissistic transference* is a post-Freudian term introduced by Heinz Kohut, in the context of his theory of narcissism, to refer to a group of clinical phenomena observed during analytic treatment.

For Freud himself, transference concerned the transposition of object relationships; transference and narcissism were such contrary ideas for him that the expression *narcissistic transference* would have been meaningless in his eyes: "Observation shows that sufferers from narcissistic neuroses have no capacity for transference or only insufficient residues of it" (1916–17a [1915–17], p. 447).

One of the first authors to take narcissism into account in the evolution of the treatment was Béla Grunberger, in 1956. Grunberger deemed narcissism one of the motors of the analytic cure, and this even among neurotics. Out of fidelity to Freud's thinking, he nevertheless refrained from using the term "narcissistic transference," and spoke only of a "narcissistic analytic relationship." In this context he described certain ploys on the part of the patient, as for example "using the analyst to create a double [or mirror] image of himself" or projecting his ideal ego onto the analyst, which would later be evoked by Heinz Kohut.

Kohut brought narcissism into relation not with the ego but with a broader and less limited entity, the self. At the same time he introduced the idea of a line of development of narcissism paralleling the development of object-cathexes and interacting with it. Narcissism and object-love were thus no longer in contradiction with each other, but complementary, and it became possible to speak meaningfully of narcissistic transferences.

In *The Analysis of the Self* (1971), Kohut describes several aspects of such transferences. "Mirror transferences" correspond to a remobilization of the idealized "grandiose self" and imply the following demand with respect to the other person: "I am perfect and need you to confirm it." A mirror transference easily gives rise to a feeling of boredom or impatience in the analyst, whose otherness it does not acknowledge. Such transferences are of three types (pp. 114–16). The most archaic is "merger transference," in which the patient strives for an omnipotent and tyrannical control over the analyst, who is experienced as an extension of the self. In an "alter-ego transference," the other is experienced as very similar

to the grandiose self. Lastly, in the case of mirror transference “in the narrower sense,” the analyst is experienced as a function serving the patient’s needs. If the patient feels recognized, he will experience sensations of well-being associated with the restoration of his narcissism. An “idealizing transference” is defined by Kohut as the mobilization of an idealized and all-powerful parent imago (p. 37), and it is encapsulated in the sentence “You are perfect, but I am part of you”; it is correlated with a struggle against feelings of emptiness and powerlessness. Kohut’s notion that certain people are cathected as parts of the self, integrated into the mental functioning of the patient himself, led him to speak of “self-objects” and to describe narcissistic transference as based on an idealized self-object.

Kohut’s approach has been criticized on the grounds that it first relegated the instincts and the Oedipus complex to the background and then eliminated them completely.

PAUL DENIS

*See also:* Bipolar self; Self; Self-object; Self psychology; Sexualization.

### **Bibliography**

- Dessuant, Pierre. (1999). *Béla Grunberger*. Paris: Presses Universitaires de France.
- Freud, Sigmund. (1916–17a [1915–17]). Introductory lectures on psycho-analysis. *SE*, 15–16.
- Grunberger, Béla. (1979 [1971]). *Narcissism: Psychoanalytic essays* (Joyce S. Diamanti, Trans.). New York: International Universities Press.
- Kohut, Heinz. (1971). *The analysis of the self*. New York: International Universities Press.
- Oppenheimer, Agnès. (1998). *Heinz Kohut*. Paris: Presses Universitaires de France.

### **Further Reading**

- Cohen, D. W. (2002). Transference and countertransference in analysis of narcissism. *Psychoanalytic Review*, 89, 631–652.
- Schwaber, Evelyn (1977). Understanding unfolding “narcissistic transference.” *International Review of Psychoanalysis*, 4, 493–502.

## **NARCISSISTIC WITHDRAWAL**

The term *narcissistic withdrawal* is used to describe the turning back of the individual’s libido from the object onto themselves. Narcissistic withdrawal is what occurs in the hallucinatory regression of dreams. This term is also used in pathology, where narcissistic withdrawal is differentiated from regression in the dream-work and must be studied in relation to the ego. Finally, in the context of psychoanalytic treatment, following Donald Winnicott (1954), regression, as a process of change, can be differentiated from withdrawal, a state that is not very productive. Thus narcissism, inseparable from the notion of regression, can be considered as a movement, with a libidinal trajectory from subject to object followed by a return of the object-cathexes to the subject.

Sigmund Freud had referred to narcissism several times before devoting a whole study to it in 1914: “On Narcissism: An Introduction.” Here he broached the notion of withdrawal: “The condition of sleep, too, resembles illness in implying a narcissistic withdrawal of the positions of the libido onto the subject’s own self, or, more precisely onto the single wish to sleep. . . . In both states we have . . . examples of changes in the distribution of libido that are consequent upon a change in the ego” (p. 83)—the ego that is manifested in the dream appearance. This withdrawal is also found in illness or pain, where libidinal cathexes are withdrawn from the object to the ego. Freud returned to this notion of regression in “A Metapsychological Supplement to the Theory of Dreams” (1916–17 [1915], where he wrote: “We distinguish two regressions—one affecting the development of the ego and the other that of the libido. In the state of sleep, the latter is carried to the point of restoring primitive narcissism, while the former goes back to the stage of hallucinatory satisfaction of wishes” (pp. 222–223). In “Mourning and Melancholia” (1916–17g [1915]), written the same year, he took up the study of the object, showing that following a disappointment linked to the object the latter is decathected of its libidinal charge, which flows back onto the ego in a movement of narcissistic regression.

In “La tendance convergente de la regression narcissique” (The tendency towards convergence in narcissistic regression; 1996), César and Sara Botella insist on “the unifying instinctual quality of narcissistic regression, for which the model is the dream-work.”

Alongside this positive approach towards narcissistic regression, we can consider the case in which the subject appeals to narcissistic withdrawal as a defensive solution. In *Life Narcissism, Death Narcissism* (1983/2001), André Green viewed narcissistic withdrawal as “yet another lure. Freud showed he was aware of this in his description of ‘Libidinal Types’ (1931). The narcissistic character type is more independent, but also more vulnerable” (p. 101). And indeed, Freud believed that evolution towards psychosis was possible in this type of personality. Green added: “The disinvestment of the object and narcissistic withdrawal expose the subject’s ego to a very threatening type of anxiety: narcissistic anxiety” (p. 101). He viewed this withdrawal as a precarious refuge that comes into being as a defense against a disappointing or untrustworthy object. This is found in studies of narcissistic personalities or borderline pathologies by authors such as Heinz Kohut or Otto Kernberg.

In conclusion, it can be said that although Freud uses the notion of withdrawal as the equivalent of narcissistic regression, in the contemporary literature the term *narcissistic withdrawal* is instead reserved for an ego defense in pathological personalities.

MARTINE MYQUEL

*See also:* Acute psychoses; Anorexia nervosa; Basic depression; Bulimia; Desexualization; Face-to-face situation; Hypochondria; Indications and contraindications for psychoanalysis in an adult; Internal object; Melancholia; Mourning; “Mourning and Melancholia”; Narcissistic neurosis; Negative, work of; Neurosis; Organ pleasure; Paranoia; Psychoanalytical nosography; Self-hatred; Sleep/wakefulness; Transference depression; Ulcerative colitis.

### **Bibliography**

- Botella, César, and Botella, Sara. (1996). La tendance convergente de la regression narcissique. *Revue française de psychosomatique*, 9, 109–125.
- Freud, Sigmund. (1914c). On narcissism: An introduction. *SE*, 14: 67–102.
- . (1916–17f [1915]). A metapsychological supplement to the theory of dreams. *SE*, 14: 217–235.
- . (1916–17g [1915]). Mourning and melancholia. *SE* 14: 237–258.
- . Libidinal types. *SE*, 21: 215–220.

Green, André. (2001). *Life narcissism, death narcissism* (Andrew Weller, Trans.). London and New York: Free Association Books. (Original work published 1983)

Winnicott, Donald W. (1954). Withdrawal and regression. In *Collected Papers*. London: Tavistock, 1958.

---

## **NARCO-ANALYSIS**

The term *narco-analysis* is derived from the Greek word *narkē* (meaning “anesthesia” or “torpor”) and is used to describe a diagnostic and psychotherapeutic technique that uses psychotropic drugs, particularly barbiturates, to induce a stupor in which mental elements with strong associated affects come to the surface, where they can be exploited by the therapist.

Narco-analysis appeared in the mid-1930s as a result of the discovery of quickly acting barbiturates with a short-term effects. The term *analysis* is used in Pierre Janet’s sense of a process that, by means of a partial dissolution of consciousness, undoes the complex syntheses of waking mental life and accesses mental content that is more automatic. Other terms have also been used, such as “narco-synthesis,” “chemical psychoanalysis” and “psychosomatic narco-analysis.”

The procedure was mainly intended for neurotic and psychosomatic patients, and it met with a certain success in treating traumatic pathologies and conditions charged with strong emotions. Applications of the technique in forensic medicine have been questioned. Narco-analysis has been used mainly in Anglo-Saxon countries.

Similar to narco-analysis is the use of other substances, such as amphetamines or psychodysleptics, with a view to creating a shock (amphetamine shock) that lifts inhibitions and reticence and promotes the emergence of major transference phenomena. In France these procedures have been used by Jean Delay at Sainte-Anne Hospital, and the good results reported related mainly to cases of hysterical conversion pathologies, hypochondria, and alcoholism. The psychoanalysts working with his department presented and commented on the effects of this treatment (Green, 1961).

VASSILIS KAPSAMBELIS

*See also:* Sainte-Anne Hospital.



**Bibliography**

Green, André. (1961). Chimiothérapies et psychothérapies. *Encéphale*, 50 (1), 29–101.

---

**NATIONAL PSYCHOLOGICAL ASSOCIATION FOR PSYCHOANALYSIS**

The National Psychological Association for Psychoanalysis (NPAP) was first organized in 1948 by Theodor Reik and a small group of student analysts. In 1950 it was incorporated as a educational membership association, under the laws of the State of New York. It is comprised of a training institute and a membership organization. NPAP is committed to training individuals from within the tri-disciplines of medicine, psychology and social work as well as other qualified persons who possess a master's degree in the humanities.

Theodor Reik immigrated to the United States in June of 1938 and settled in New York City. Because he possessed a PhD in psychology, rather than a degree in medicine, he was denied full membership in the New York Psychoanalytic Society. When Freud (1926e) wrote *The Question of Lay Analysis*, in defense of Theodor Reik, he defined the philosophy to which NPAP has been committed since its inception. That is, not merely that a medical degree was not necessary for the practice of psychoanalysis but that restricting training exclusively to those who had such a degree evidenced a misunderstanding of what psychoanalysis was and could become.

Reik was most known for his many publications, and particularly for *Listening with the Third Ear* (1956). His small group of students, from outside the medical field, has grown to number, as of 2000, more than 350 members and more than 175 enrolled students. During its history, NPAP has significantly influenced psychoanalytic training, particularly in New York City. A majority of the founding members of such organizations as The Institute for Psychoanalytic Training and Research (IPTAR), The New York Freudian Society, and the New York Center for Psychoanalytic Training, were trained by NPAP. Many organizations outside New York City also trace their origins to NPAP.

By supporting groups and organizations dedicated to keeping psychoanalytic training open to qualified individuals, NPAP has been a leading force in the Uni-

ted States for the training and recognition of non-medical psychoanalysts. Although committed to its Freudian tradition, NPAP also encompasses object relations theorists as well as self-psychology theorists. Its institutional structure is democratic, as evidenced by its allowing student-candidates to choose their own analyst and control analysts from among the entire membership list. Training analysts are not permitted to report back to the institute. The training requirements are: (1) the completion of twenty-six courses, (2) a minimum of a thrice-weekly analysis for four hundred and fifty sessions, (3) one hundred and fifty sessions of control-analysis supervision and (4) case presentation, before a board of five members. Upon graduation all members are approved as training analysts and control analysts.

Since the 1960s NPAP has sponsored a referral service, The Theodor Reik Clinical Center for Psychotherapy, offering low-cost psychoanalysis and psychoanalytic psychotherapy to qualified persons. The Association publishes *The Psychoanalytic Review* as well as the in-house journal *News and Reviews*. It has an extensive psychoanalytic library and holds monthly scientific meetings.

NPAP is a member of the World Federation for Mental Health and a founding member of The Council of Psychoanalytic Psychotherapists and The International Federation for Psychoanalytic Education.

GERALD J. GARGIULO

*See also:* Lay analysis; New York Freudian Society; *Psychoanalytic Review*, *The*; Reik, Theodor; Second World War: The effect on the development of psychoanalysis; Splits in psychoanalysis.

**Bibliography**

Freud, Sigmund. (1926e). The question of lay analysis. *SE*, 20: 177–250.

Reik Theodor. (1948–1956). *Listening with the third ear*. New York: Grove Press.

——— (1956). *The search within. The inner experiences of a psychoanalyst*. New York: Farrar, Straus & Cudahy.

---

**NEED FOR CAUSALITY**

According to Freud, no innate need for causality exists in the human mental apparatus, rather, such a need is

itself the result of a practical interest (*praktisches Interesse*).

Regarding the awakening in the infant of the impulse to investigate (1905d), he emphasizes that the interest that impels the infant to research is not theoretical (*nicht theoretisch*). This means that it is has no relation of the drive for knowledge—where it is precisely a matter of establishing origins—but rather that it is practical and is related in this instance to egoistic drives (*eigensüchtige Triebe*), that is, to the ego-drives. These drives, in fact, claim the entire love of the parents and, in order to guard against the danger of the appearance of younger siblings, will force the activity of thought in the direction of investigation. Likewise, in reference to primitive peoples, Freud thought that “What released the spirit of enquiry in man was not the intellectual enigma [of death], and not every death, but the conflict of feeling at the death of loved yet alien and hated persons” (1915b, p. 293).

Freud did not deny that causality could at a given moment create the object of a need, but he based it on other more primitive needs or gave it an origin, in the above case the conflict of ambivalence. The enigma, as Freud saw it, was a product of the urgency of life (*Lebensnot*), which emphasizes both its restrictive character and the fact that it does not depend on a desire to know, but rather on the necessity of knowing as a means of self-preservation.

Once this origin was established, Freud emphasized the need for causality, but more often it took the form of illusion insofar as its only object could be a unique exhaustive explanation. “It is enough for our need to discover causes (which, to be sure, is imperative) if each event has *one* demonstrable cause” (1939a [1934–1938], p. 107). This unitary fantasy is the root of every *Weltanschauung*, defined as an “intellectual construction which solves all the problems uniformly on the basis of one overriding hypothesis, which, accordingly, leaves no question unanswered and in which everything that interests us finds its fixed place. It will easily be understood that the possession of a *Weltanschauung* of this kind is among the ideal wishes of human beings” (1933a [1932], p. 158).

He had, regarding the dynamics of the transference (1912b), noted that “in contrast to what ordinarily holds good for the real world, people prefer to be satisfied with a single causative factor” (p. 99n) and already in 1909, in *Five Lectures*, he spoke of fact that “what

seems to be our innate craving for causality declares itself satisfied with a single psychological cause” (p. 38). The question of a need for causality is, for Freud, mired in the necessity to defend intellectualist idealization. The need for causality that motivated, at each step, his own research was linked together with and humbled by the resistance of reality and, in his case, clinical experience.

The position of Piera Aulagnier on the question of causality is different from Freud’s because she starts with the experience of a dispossession of the search for causes and a negation of this need in psychotics. The need for causality, a notion that this author attributes to Ernst Cassirer, is merged in her work with a need for identification. The questioning of the child does not inquire so much about the threat of the birth of younger sibling, but rather the desire of the parents who were able to cause the child’s own birth. Far from being abstract or superfluous, causality bears upon desire: the wish to know what causes the mother’s desire (once the child stopped trying to be its unique object) and to know what causes the world to be as it is, necessitates a “contriving from what seems true (which does not necessarily mean what is true), from meaning, even while there is a risk of the irruption of the non-meaning and the not-known of desire” (1967). Making sense seems to be the work of the I, and also what makes it emerge as such, and in such a way that “the causal explication becomes, for thought, part of necessity” (1979).

Aulagnier found that in psychosis, before the delusional reconstruction, it is precisely the need for causality that is confronted with “the collapse of the function of signification” (1979). The delusion, in turn, has the function of creating a “reasonable interpretation of the violence suffered.”

In this understanding, the creation of meaning by the I implies in effect that it is capable of thinking of itself as a being that is not just the reduplication of what preceded it, that has had a history of its own and is going to know a future full of changes. The need for causality, for from being reducible to a single cause, encompasses the multiplicity of all the causal events of the past. Conversely, in psychosis, causality is self-created, a pure repetition of what has already been. Aulagnier writes, “The fantasy of self creation that we see in certain forms of psychosis is most often able to be decoded, when it is looked at closely, as a fantasy that attributes to the subject the power to engender

not only its own past, but all of the past, not only its own origin, but the origin of everything” (1984). In this case, the need for causality does not disappear, but is limited to a unique cause that is the subject itself.

SOPHIE DE MIJOLLA-MELLOR

*See also:* Animistic thought; Death and psychoanalysis; Determinism; Infantile sexual theories; Knowledge or research, instinct for; Logic(s); Psychic causality; Psycho-genesis/organogenesis; Sense/nonsense; Synchronicity; Thought.

### **Bibliography**

Aulagnier, Piera. (1967). *Le désir de savoir dans ses rapports à la transgression. L'Inconscient. 1* (Reprinted in *Un interprète en quête de sens*. Paris: Ramsay, 1986).

———. (1979). *Les destins du plaisir. Aliénation, amour, passion*. Paris: Presses Universitaires de France.

———. (1984). *L'Apprenti-historien et le maître-sorcier: Du discours identifiant au discours délirant*. Paris: Presses Universitaires de France.

Freud, Sigmund. (1910a). Five lectures on psycho-analysis. *SE*, 11: 7–55.

———. (1912b). The dynamics of transference. *SE*, 12: 97–108.

———. (1915b). Thoughts for the times on war and death. *SE*, 14: 273–300.

———. (1933a [1932]). New introductory lectures on psycho-analysis. *SE*, 22: 1–182.

## **NEED FOR PUNISHMENT**

The need for punishment is an internal need of some individuals to seek out painful or humiliating situations and to take pleasure in them. For Laplanche and Pontalis (1973), basic to such behavior is a link to the death drive.

Freud referred to the need for punishment for the first time in *The Interpretation of Dreams* (1900a) in discussing “punishment dreams.” Such dreams are the fulfillment of an unconscious desire to be punished for a suppressed or forbidden impulse.

The need for punishment directs the sadism found in all libidinal urges toward the ego. Feelings of guilt can develop only when the subject, in an ambivalent

state in which love and hate both subsist, attempts to find an equilibrium. When repression leads to neurosis, the libidinal tendencies are transformed into symptoms, and aggression becomes a feeling of guilt.

It is always possible to distinguish the feeling of guilt as such from the need to atone. The first expresses a yearning to refind the (annihilated) lost object, while the second expresses a need for punishment after the subject repeats the act. The feeling of guilt is therefore in the service of an unsatisfied object-libido; the need to atone is related to eroticized destructive drives and is directed against the ego. The need for punishment is a consequence of the feeling of guilt, even though they seem closely linked and have common phylogenetic roots.

Suffering and inclinations toward self-punishment are expressions of a tendency toward self-annihilation. This tendency reaches its culmination in the suicide of a melancholic, whom the need for punishment comes to dominate to such an extent that he could commit a real crime solely to justify his torment and obtain relief by atonement.

Many authors do not clearly distinguish between the need for punishment and other notions such as moral masochism and negative therapeutic reaction, which they consider to be part of the need for punishment.

LEÓN GRINBERG

*See also:* Basic Neurosis, The—Oral Regression and Psychic Masochism; Castration complex; Civilization and Its Discontents; “Dostoyevsky and Parricide”; Ego psychology; Guilt, feelings of; Law and psychoanalysis; Masochism; Moral masochism; Negative therapeutic reaction; Parricide; Punishment, dream of; Reparation; Self-punishment; Superego.

### **Bibliography**

Freud, Sigmund. (1900a). The interpretation of dreams. *SE*, 4: 1–338; 5: 339–625.

Laplanche, Jean, and Pontalis, Jean-Bertrand. (1973). *The language of psycho-analysis* (Donald Nicholson-Smith, Trans.). New York: W. W. Norton. (Original work published 1967)

### **Further Reading**

Alexander, Franz. (1929). The need for punishment and the death instinct., *International Journal of Psychoanalysis* 10, 256–269.

Fenichel, Otto. (1928). The clinical aspect of the need for punishment. *International Journal of Psychoanalysis*, 9, 47–70.

Nunberg, Henry. (1926). The sense of guilt and the need for punishment. *International Journal of Psychoanalysis*, 7, 420–433.

## NEGATION

The term *negation* (*Verneinung*) denotes a mental process in which the subject formulates the content of an unconscious wish in a negative form. The content of the wish finds expression in consciousness, yet the subject continues to disown it.

This concept first appeared in Freud's work in connection with the analysis of the "Rat Man" when the patient produced an association having to do with the death of his father but immediately "rejects the idea with energy" (1909d, p. 178). Yet Freud's main discussion of the topic appears in "Negation" (1925h), where he sets forth a theory of negation that is close to being a theory of forms of language or a theory of judgment.

Freud posits two distinct processes of negation: one involves the rejection of a thought, the other the acknowledgment of a disappointed expectation. The first kind of negation, involving rejection, is the kind encountered in the "Rat Man" case. Another example is when a patient refuses to believe that the woman he has just dreamed about is his mother: "You're going to think it was my mother," he will say to the analyst, "but it wasn't my mother." This negation may be interpreted to mean, "I reject the idea that this person could be my mother because I dislike that idea." Negation is a rejection of an unpleasant idea by means of the pleasure principle alone. The process of projection is already at work in the utterance "You're going to think it was my mother," for in this way the patient projects into the mind of the analyst a thought that is in fact the patient's.

Negation as a defense mechanism is more supple than repression in that it preserves the thought content that repression would render unconscious. The defensive aspect of the mechanism is confined to the distancing achieved by means of the negation, which allows the patient to avoid shouldering the disagreeable implications of a thought that has successfully formed.

In addition to this first kind of negation, Freud describes a second type, namely a judgment by a psyche that fails to encounter in the outside world a satisfying mental representation of what it desires. The psyche is then obliged to arrive at the negative conclusion that what it has been seeking in external reality is indeed not present. This type of negation thus amounts to an assertion of absence. In making this assertion, the psyche recognizes the independent existence of the outside world and, thus achieving effective reality-testing.

The idea of negation lies at the center of a very dense conceptual nexus within the Freudian model. Several other terms are closely linked to *Verneinung* (negation) and overlap with it in meaning to a greater or lesser extent. Occasionally Freud used the Latinate German term *die Negation* to refer to a basic trait of the "system Ucs.," in which there is "no negation" (1915e, p. 186). This enabled him to define the system of the unconscious as prior to intellectual judgment. By contrast, the Germanic word *Verneinung*, embracing as it does both negation as a mental process and negation as a grammatical form, presupposes a psychic agency capable of making judgments.

In Freud's usage there is a wider difference in meaning between *Verneinung* and *Verleugnen*, which is translated into English as either "denial" or (following the preference of the editors of the *Standard Edition*) "disavowal." In the process of disavowal, the subject refuses to embrace the psychic consequences of something perceived. Thus the "Wolf Man" (1918b [1914]) said, in effect, "I see that a woman does not have a penis, but I deny any force to this observation, and what is more, I shall continue to believe that she has a penis." In disavowal, a reality judgment produces a conclusion ("A woman does not have a penis"), but this conclusion is a dead letter having no impact on the psyche. Thus the recognition of a reality ("[I see that] a woman does not have a penis") is juxtaposed to a wish ("[I want] a woman to have a penis") without being integrated together. In both disavowal and negation, the subject avoids responsibility for a disagreeable thought. The two differ, however, in that disavowal is rejection of a disagreeable perception, whereas negation is the acceptance of a wish.

Lastly, the term *foreclosure* (French *forclusion*) was introduced by Jacques Lacan to render Freud's use of the term *Verwerfung* in connection with the psychotic

mechanism of “expulsion of a fundamental ‘signifier’” (Laplanche and Pontalis, 1973, p. 166).

The theory of negation is no doubt an area where the psychoanalytic theorization of mental processes comes very close to linguistic concerns, especially to the study of utterances. From a linguistic standpoint, one might say that negation in the sense of rejection is equivalent to a polemical negation (as in, for example, “For me, this woman in my dream is not my mother”), whereas the recognition of absence—a negation that can be expressed as a reality judgment—is equivalent to a “simple” negative report, much like a statement such as “I have not had a dream for a long time.”

Clear boundaries need to be drawn between negation, absence, and the idea or representation of absence. These distinctions, in broad outline, are as follows. In all cases, negation is directed at an ideational content. This content, in the context of the theory of the hallucinatory satisfaction of a wish, emerges as a consequence of the absence of the wished-for object. This absence obliges the subject to hallucinate, to represent, the missing object. Absence is thus a precondition of the emergence of the representation. In this regard, absence is distinct from negation, which is an operation affecting an ideational content. As for the representation of absence, it arises only after the capacity for judging reality has been established, when the subject is able to articulate the gap between what he wants and what he sees.

LAURENT DANON-BOILEAU

*See also:* Binding/unbinding of the instincts; Constructions in analysis; Contradiction; Death and psychoanalysis; Death instinct (Thanatos); Defense; Disavowal, denial; *Ego and the Mechanisms of Defence, The*; Id; “Negation”; Primitive; Projection; Splitting.

### Bibliography

- Freud, Sigmund. (1909d). Notes upon a case of obsessional neurosis. *SE*, 10: 151–318.
- . (1915e). The unconscious. *SE*, 14: 159–204.
- . (1918b [1914]). From the history of an infantile neurosis. *SE*, 17: 1–122.
- . (1925h). Negation. *SE*, 19: 233–239.
- Hyppolite, Jean. (1988). A spoken commentary on Freud’s *Verneinung*. In *The seminar of Jacques Lacan. Book 1: Freud’s papers on technique, 1953–1954* (John Forrester,

Trans.). New York: W. W. Norton. (Original work published 1954)

Lacan, Jacques. (1988). Introduction and reply to Jean Hyppolite’s presentation of Freud’s *Verneinung*. In *The seminar of Jacques Lacan. Book 1: Freud’s papers on technique, 1953–1954* (John Forrester, Trans.). New York: W. W. Norton. (Original work published 1954)

Laplanche, Jean, and Pontalis, Jean-Bertrand. (1973). *The language of psycho-analysis* (Donald Nicholson-Smith, Trans.). London: Hogarth and the Institute of Psycho-Analysis. (Original work published 1967)

### Further Reading

- Litowitz, Bonnie. (1998). An expanded developmental line for negation. *Journal of the American Psychoanalytic Association*, 46, 121–148.
- Tyson, Robert L. (1994). Neurotic negativism and negation in the psychoanalytic situation. *Psychoanalytic Study of the Child*, 49, 293–314.

## “NEGATION”

Written by Freud after “A Note upon the ‘Mystic Writing-Pad’” (1925a), this article was first published in the review *Imago*.

Seen in its clinical context, negation dramatizes a situation of interpretative conflict. The patient first produces the interpretation, which he imputes to the psychoanalyst, claiming that it is false. Negation is thus related to a dialogical situation: “Now you’ll think I mean . . . but really I’ve no such intention.” (1925h, p. 235).

Returning to a distinction he had established in the analysis of the “Rat Man” (“Notes upon a Case of Obsessional Neurosis,” 1909) between the pure “ideational content” (“Notes,” p. 176) and the positive or negative judgment in which it is incorporated, Freud says that the contribution of the unconscious to knowledge consists in the access it grants us to the repressed content. This knowledge of the repressed content does not require a lifting of repression. The dichotomy is thus displaced, and the pair of opposites affirmation/negation is eclipsed by the opposition between the affective and the intellectual. “[I]ntellectual acceptance of the repressed” (1925h, p. 236) leaves the process of repression intact, since this latter consists in a process of separation. But isn’t the phrase “intellectual acceptance” a contradiction in terms? The

compromise in which negation consists thus seems to make it possible, if not to lift the repression, at least to uncover the repressed content.

Over and above registering the content, the function of judgment is, Freud states, to produce “decisions” (*Entscheidungen*). Taking up the philosophical distinction between judgments of attribution and judgments of existence, Freud describes two levels of psychic working-through. The first level consists in attributing a good or bad quality to something, and is linked to the instinctual impulses that drive the original pleasure-ego, which “wants to introject into itself everything that is good and to eject from itself everything that is bad” (p. 237). The decision of judgment thus plays the decisive role in operations determined by instinctual factors, swallowing and spitting—operations that establish the first distinction between inside and outside. Freud’s insistence here on the instinctual dimension of negation met with a certain reservation on the part of Jean Hyppolite: “There is not yet any judgment in this moment of emergence; there is the first myth of inside and outside.” So we might think in terms of a first evaluation that, when it is positive, leads the object to disappear within an enriched pleasure-ego, rather than an operation of judgment bearing on an external object.

In order for the second level of judgment to intervene and decide whether the object actually exists or not, a certain mediation is necessary—that of representation, attesting to the reality of the represented. The definition of the judgment of existence thus ties in with the notion of reality-testing and rests on the occurrence of a cut that is linked with the loss of the primal objects. However, the judgment of existence cannot be defined as a mere process of thought, because it is related to a motor process that “puts an end to the postponement due to thought . . . and leads over from thinking to acting” (p. 238).

In counter-distinction to the theme put forward in “Moses and Monotheism: Three Essays” (1939 [1934–38]), with its emphasis on the cut between the sensory and the intellectual domains, the study of negation invites us to see the processes at work in sense-perception as lying at the very heart of intellectual operations: tactile exploration (*tasten*) and the fact of tasting (*verkosten*) small perceptual samples, which endows the processes of thought with a two-phase temporality, made up of advances and retreats. Should this participation of two aims be understood in terms of rhythm,

or related to the opposition between Eros, which upholds affirmation, and Thanatos, which upholds negation?

The last section of Freud’s text returns to the topographical question: Negation, unknown at the level of the unconscious, needs to be situated on a secondary level, and we can gain access to it only by way of the symbol. The study of the interrelation of oral instinctual motions and the establishment of negative and affirmative behavior has been further investigated in the works of René Spitz.

MONIQUE SCHNEIDER

*See also:* Ego; Purified-pleasure-ego; Negation; Negative, work of; Thought; Working-through.

### Source Citation

Freud, Sigmund. (1925h). Die Verneinung. *Imago*, XI, 217–221; *G.W.*, XIV, p. 11–15; Negation. *SE*, 19: 233–239.

### Bibliography

Freud, Sigmund. (1909d). Notes upon a case of obsessional neurosis. *SE*, 10: 151–318.

Hyppolite, Jean. (1971). *Figures de la pensée philosophique; écrits de Jean Hyppolite (1931–1968)*. Paris: Presses Universitaires de France.

Kaës, René. (1988). Le pacte dénégatif dans les ensembles transsubjectifs. In A. Missenard (Trans.), *Le Négatif. Figures et modalités* (pp. 101–136). Paris: Dunod.

Lacan, Jacques. (1966). *Écrits*. Paris: Le Seuil.

Roussang, François. (1984). Comment devenir un inspire raisonnable. *Philosophie* 3, 47–66.

Spitz, René. (1957). *No and yes; on the genesis of human communication*. New York: International Universities Press.

---

## NEGATIVE CAPABILITY

Wilfred Bion, having discovered the importance of the mother’s (and by association, the analyst’s) capacity to tolerate the infant’s (and patient’s) projective identifications, sought a source for this tolerance. He reasoned that in analysis, the analyst must possess the capacity for patience and be able to have faith that in time he will be able to find the “selected fact” (Henri

Poincaré) which unites the apparent randomness of the analysand's associations. *Negative capability* is the capacity to tolerate frustration because of the faith that meaning can ultimately be found.

Bion associates it with the capacity of the "Man of Achievement," following a passage in Keats which Bion often cited: "I had not a dispute but a disquisition with John Dilke on various subjects; several things dove-tailed in my mind, and at once it struck me what quality went to form a Man of Achievement, especially in Literature, and which Shakespeare possessed so enormously. I mean Negative Capability, that is, when a man is capable of being in uncertainties, mysteries, doubts, without any irritable reaching after fact and reason" (Bion, 1970).

Negative capability and the man of achievement were concepts that prefigured Bion's later idea of transformations in "O," by which he meant a domain that is beyond sensing, imagining, or knowing. One just becomes "O." In order to achieve a resonance with this unknowable domain either within oneself and/or in relationship to the other as subject, one must have patience that clarity will ultimately arrive with the destined selected fact and that coherence will emerge.

Bion was thus suggesting, in his anticipation of post-modern non-determinism, that the analytic field bears more resemblance to chaos, beta elements, "thoughts without a thinker," "things-in-themselves," noumena, than they do to deterministic concepts such as drives, or instincts, or the like. Consequently, the analyst who is to become an "analyst of achievement" must be able forswear knowing or having to know, so that he can be free to intuit and ultimately to realize.

Bion later seemed to link negative capability with reverie, which means the acceptance of and surrender to a state of ultimate timeless receptiveness without desire, memory (preconceptions), or the need to understand—just to be there with the analysand. This state of mind and of the receptivity associated with it allows the analyst to be all the more open to his own psychic reality (internal world), where his intuition about the analysand's experiences with him and of him are directly felt.

JAMES S. GROSTEIN

*See also:* Alpha function; Attention; Non-verbal communication; Lack of differentiation; Maternal reverie, capacity for; Primary object.

### **Bibliography**

Bion, Wilfred R. (1970). *Attention and interpretation*. London, Tavistock Publications.

---

## **NEGATIVE HALLUCINATION**

Negative hallucination is the active erasure of a perception; it produces a gap in reality, or a vague impression of unreality.

The term first appeared in "Psychical (or Mental) Treatment" (Freud, 1890), an article relating to hypnosis. Freud wrote that it was possible to suggest to a hypnotized subject that he or she not see a person or thing that would be present to the subject upon awakening; in such cases the object appears to be "thin air" (p. 297). Freud borrowed this notion from Hippolyte Bernheim, with whom he studied to perfect his hypnotic technique.

Reading Freud's first references to hypnosis and hysteria, or *The Psychopathology of Everyday Life* (1901), one might be inclined to link negative hallucination to repression involving not thought, but perception. Indeed, early in his work Freud did not theorize the more archaic mechanisms; for lack of these, he spoke in terms of massive forms of repression (rejection of reality, primary repression, etc.). Thus, according to Freud in "Delusions and Dreams in Jensen's 'Gradiva,'" (1907 [1906]), Norbert Hanold, the hero of Wilhelm Jensen's story, having repressed the totality of his love life, suffers from a propensity to negative hallucination that paves the way for hysterical delusions. Freud also evoked a form of hysteria, hysterical terror that is induced by major traumas that erase lived impressions and can produce "gaps in the psyche" as the origin of a psychosis.

Present in outline here is a more specific conception of negative hallucination, later formulated in "A Metapsychological Supplement to the Theory of Dreams" (1916–1917 [1915]); it posits that negative hallucination has a sort of logical anteriority relative to positive hallucination. Freud pursued this idea in 1924 in relation to hallucinatory confusion, speculating that when an unbearable reality cannot be perceived, a delusion appears to close the perceptual breach.

Among Freud's successors, Sándor Ferenczi (1929) was most active in developing the idea that psychosis is constituted in two phases. In his view, the first phase

of negative hallucination is a narcissistic protection against the traumatic influx of excitations, while the second phase is the compensatory production of positive hallucinations or delusions. More recent authors (Margaret Mahler, Frances Tustin) have instead focused on the massive forms of negative hallucination of the external world in the severe psychoses.

From 1977 to 1994, André Green reexamined negative hallucination and gave it an important place in theory and clinical practice. In his view, the mother's negative hallucination is a necessary condition for the child's ideational abilities. It is the blank screen (a theme borrowed from Bertram Lewin), the canvas on which representations are registered. In the child's representational process, the mother's negative hallucination is registered as a border, or frame for the process. Green used the example of the famous hallucination of the "Wolf Man"; the hallucination of the severed finger thus forming the connection between this process and the borderline states between neurosis and psychosis. In recent work, Green proposed a mechanism for negative hallucination in response to objections that had been raised about the scope of the concept; negative hallucination occurs when there is a convergence of quantities of excitation coming from the interior and the exterior, between a traumatic trace and an actual perception that reactivates it.

Following Green's lead, other authors have returned to this notion. In "Nouveaux développements sur l'hallucination négative et la représentation" (1992; New developments on negative hallucination and representation), François Duparc examined Freud's references to it, arguing that beyond hysterical repression or the early signs of psychosis, a close connection between negative hallucination and denial can be grasped from many of Freud's texts. For instance, in "Some Psychological Consequences of the Anatomical Distinction between the Sexes" (1925), Freud wrote: "[W]hen a little boy first catches sight of a girl's genital region, he begins by showing irresolution and lack of interest; he sees nothing or disavows what he has seen, he softens it down or looks about for expedients for bringing it into line with his expectations" (p. 252). Denial is posited as a means of attenuating perception, a defense that is less costly, in terms of counter-cathetic energy, than the urgent, transitory suppression involved in negative hallucination, a more primitive mechanism that attacks the subject's connection with reality. In order to avoid the return of what has been

refused, structures that transform reality into denial of reality—the origin of all sorts of pathologies. Duparc thus linked negative hallucination to the lateral cathexis of fetishism, to motor escape in manic defenses and allergies, and to chemical escape in substance abusers. He described different modes of negative hallucination that depend on the primal motor forms used to construct white noise, the screen that makes it possible to negate perception.

FRANÇOIS DUPARC

*See also:* Absence; *Delusions and Dreams in Jensen's "Gradiva"*; Wish, hallucinatory satisfaction of a; Representability; Hallucinatory, the; Dead mother complex; Negative, work of; Work (as a psychoanalytical notion).

### Bibliography

- Duparc, François. (1992). Nouveaux développements sur l'hallucination négative et la représentation. *Revue française de psychanalyse*, 56 (1), 101–121.
- . (1997). Hallucination négative, formes motrices et comportements autocalmants. In *Cliniques Psychosomatiques*. Paris: Presses Universitaires de France.
- Ferenczi, Sándor. (1929). The unwelcome child and the death instinct. *International Journal of Psychoanalysis*, 10, 125–129.
- Green, André. (1977). L'hallucination négative, note pour un addendum pour un traité des hallucinations. *L'Évolution Psychiatrique*, 62 (2), 645–656.
- . (1994). *Somatization. Psychanalyse et science du vivant*. Paris: Eschel.

## NEGATIVE THERAPEUTIC REACTION

The expression "negative therapeutic reaction" is used to describe a situation in clinical practice wherein there is an exacerbation of the patient's symptoms following a correct series of interpretations. According to Sigmund Freud, this phenomenon was caused by unconscious feelings of guilt, as seen in primary masochism, which he ultimately linked to the death drive. The negative therapeutic reaction has also come to be regarded as an essential key to understanding the limits of ego functioning.

Freud described the negative therapeutic reaction in *The Ego and the Id* (1923b) as an "inverted" reaction,



the patient preferring to suffer than be cured: “The need for illness has got the upper hand in them over the desire for recovery” (p. 49). For Freud this was the expression of a feeling of guilt that found its satisfaction in the state of illness and sought punishment through suffering. This feeling of guilt is difficult to bring to light, because it remains “silent” for the patient, who does not feel guilty, but rather ill. It manifests itself in a resistance to being treated and Freud regarded it as very difficult to overcome.

In “The Economic Problem of Masochism” (1924c), Freud emphasized the fact that the way the unconscious feeling of guilt is satisfied is directly related to the subjective benefit brought by the illness: “The suffering entailed by neuroses is precisely the factor that makes them valuable to the masochistic trend” (p. 166). He thus contrasts the sadism of the superego, which is usually conscious, with the masochism of the ego, which generally remains unconscious. He proposes replacing the expression “unconscious feeling of guilt” with that of “need for punishment.”

In “Analysis Terminable and Interminable” (1937c), Freud linked the negative therapeutic reaction, ultimately, to the workings of the death drive, as the phenomenon of resistance to the cure could not be explained as a mere function of the pleasure principle.

Thus, after the second topic, whenever Freud described the negative therapeutic reaction, he emphasized the need for self-punishment, the severity of the superego and the masochism of the ego. All the self-hatred inside these subjects, driven as they are by a logic of despair, reflects a compromise between an unquenchable desire for vengeance and the need to protect the object from the hostile desires directed against it. The conflict between love and hatred is here predominant, and “if love is always uncertain, hatred is always sure” (Green, 1990), with the result that these subjects do everything to ensure that the form of sado-masochistic relation that they have chosen can be perpetuated for as long as possible.

Thus, the new theorization of the unconscious feeling of guilt that the second topic makes possible offers a logical explanation for the status of suffering: displeasure for one system (the ego), and pleasure for another (the superego); ipso facto, it provides us with a precise economic definition of the negative therapeutic reaction. If the death drive essentially works in

silence and is observable only in a form interwoven with the life instinct, the negative therapeutic reaction, through the notion of a cruel and severe superego, and especially through the idea of primary and secondary masochism, offered Freud the possibility of giving a precise clinical form to this speculation. It is, indeed, observable in the process of treatment and thus can in certain conditions be analyzed.

Psychoanalysts have often used the expression negative therapeutic reaction descriptively, to designate the forms of resistance to change that are particularly difficult to overcome in treatment. Jean-Bertrand Pontalis (1981), following several other authors, has criticized the attitude that too easily attributed the reasons for the failure of treatment to the psychic structure of the patient, thereby over-hastily freeing the analyst from their own therapeutic responsibilities. The struggle must not be abandoned in the face of the silent work of the death drive, that “force which is defending itself by every possible means against recovery and which is absolutely resolved to hold on to illness and suffering” (Freud, 1937c, p. 242).

Pontalis has emphasized how often the negative therapeutic reaction has been invoked by analysts to justify their sense of discouragement and how much it needs, in such cases, to be understood as “[their] reaction to those who cause their method to fail merely by saying no.” The analyses considered as failures should in fact be understood in relation to the particularities of the transference and counter-transference.

Some authors have attempted to reply to these questions. For Joan Rivière, it is by means of a sort of “self-sacrifice” that these patients refuse to be cured until they have cured their primary internal objects. Harold Searles sees it as the expression of an unconscious tendency to look after the analyst, which is to say the mother. These studies do indeed underline how at the heart of the negative therapeutic reaction there is clearly “the crazy passion to cure the crazy mother inside the Self (Pontalis, 1981).

René Roussillon (1991) has shown that the main clinical phenomenon is constituted by the pair of opposites “paradoxical improvement/worsening.” Influenced by the studies of Donald Winnicott, he stresses the role of unintegrated and unsymbolized traumatic experiences that remain split off within the psyche and lead to a permanent disorganization in the subject. For him, Freud applied the name “negative

therapeutic reaction” to those moments in the treatment when the patient is overwhelmed by disorganizing experiences, traces of “primal agonies,” moments of “psychic death” undergone long ago. The therapeutic process leads the subject to relive those unsymbolized and unintegrated traumatic states. Didier Anzieu has also given the name “paradoxical transference” to this type of situation, one form of which is an intense emotional transference.

Thus, when it can be combined with the analytical work of co-construction, the negative therapeutic reaction no longer appears merely as a troublesome disruption in the analysis, but as an essential way of tackling and working through the functions of the ego that treatment can reveal only in this form. Thus it is the sign that a traumatic kernel is about to be actualized in the analytical space, thereby opening the way for its transference and working-through.

JEAN-FRANÇOIS RABAIN

*See also:* “Analysis, Terminable and Interminable”; Analyzability; “Constructions in Analysis”; Counter-transference; Cure; Death instinct (Thanatos); *Ego and the Id, The*; Moral masochism; Need for punishment; Pain; Psychoanalytic treatment; *Remembering, Repeating and Working-Through*; Resistance; Self-punishment; Suicide; Superego; Transference; Transference hatred.

### **Bibliography**

- Anzieu, Didier. (1975). Le transfert paradoxal. *Nouvelle Revue de Psychanalyse*, 12, 49–72.
- Laplanche, Jean, and Pontalis, Jean-Bertrand. (1988). *The language of psycho-analysis* (Donald Nicholson-Smith, Trans.) London: Karnac and the Institute of Psycho-Analysis. (Original work published 1967)
- Pontalis, Jean-Bertrand. (1981). Non, deux fois non. *Nouvelle Revue de Psychanalyse*, 24.
- Revue Française de Psychanalyse. (2000). Le transfert négatif. *Revue française de psychanalyse*, 64, 2.
- Roussillon, René. (1991). *Paradoxes et situations limites de la psychanalyse*. Paris: Presses Universitaires de France.

## **NEGATIVE TRANSFERENCE**

The term *negative transference* refers to the aspects of the transference that counter the progress of psycho-

analytic treatment. It is thus not a matter simply of the patient’s expressing hostile feelings towards the analyst—which may in fact be helpful to the treatment—but rather negative feelings toward the person of the analyst that strengthen resistances and may bring analytic work to a halt whether or not the sessions are actually broken off.

Freud evoked these difficulties as early as the *Studies on Hysteria* (1895d): “If, now, this relation of the patient to the physician is disturbed, her cooperativeness fails, too; when the physician tries to investigate the next pathological idea, the patient is held up by an intervening consciousness of the complaints against the physician that have been accumulating in her.” Freud described three main types of cases in which this occurred: cases where “the patient feels she has been neglected, has been too little appreciated or has been insulted”; cases where “the patient is seized by a dread of becoming too much accustomed to the physician personally, of losing her independence in relation to him, and even of perhaps becoming sexually dependent on him”; and, lastly, cases where the patient is afraid of “finding that she is transferring on to the figure of the physician the distressing ideas which arise from the content of the analysis” (pp. 301–302).

The actual expression “negative transference” made its first appearance in Freud’s “The Dynamics of Transference” (1912b): “We must make up our minds to distinguish a ‘positive’ transference from a ‘negative’ one, the transference of affectionate feelings from that of hostile ones, and to treat the two sorts of transference to the doctor separately.” The transference onto the person of the analyst “is suitable for resistance to the treatment only in so far as it is a negative transference or a positive transference of repressed erotic wishes” (p. 105).

After 1920, Freud linked negative transference to the repetition compulsion and the death instinct. In his wake, the Kleinians would lay justifiable stress on the analysis of negative transference. Thus Melanie Klein rebuked Anna Freud for not analyzing it in children, and, in “Some Theoretical Conclusions Regarding the Emotional Life of the Infant,” recommended that the reinforcement of the positive transference not be systematically pursued, but rather that the analyst should at times allow himself to “stand for frightening figures, [for] only in this way can the infantile persecu-

tory anxieties be fully experienced, worked through and diminished” (1975 [1952], p. 90, n. 2).

The two aspects of the transference always coexist, but they do not always appear simultaneously. Hostile feelings towards the analyst does not inevitably mean a negative transference; it may indicate reaction formations, which can augur well for the progress of the treatment, since they are in fact defenses against a positive transference. Conversely, negative transference may have an indirect role only, in the background to a manifest positive transference, yet effectively undermine all therapeutic progress. The absence of forward motion in an analysis may indeed be the only sign of negative transference. Freud himself pointed out that “Bitterness against men is as a rule easy to gratify upon the physician; it need not evoke any violent emotional manifestations, it simply expresses itself by rendering futile all his endeavours and by clinging to the illness” (1920a, p. 164). The negative transference thus means that “the ego treats recovery itself as a new danger” (1937c, p. 238). It may also have a retroactive impact: “If the negative transference gains the upper hand,” the successes of the therapy “are blown away like chaff before the wind” (1940a [1938], p. 176).

It is essential to underline that in Freud’s eyes negative transference was an aspect of the transference in the fullest sense: it represented a repetition of a relationship in the patient’s childhood and had to be interpreted accordingly. Thus the analyst should offer very little gratification to the patient, as this complaisance might hinder the externalization of the patient’s hostile feelings and deprive the analyst of opportunities to tackle them.

Most authors concur that inadequate analysis of negative transference or of hate in the transference are at the root of psychoanalytic failures. As Freud observed, “Under the influence of the unpleasurable impulses which [the patient] feels as a result of the fresh activation of his defensive conflicts, negative transferences may now gain the upper hand and completely annul the analytic situation” (1937c, p. 239). When Sándor Ferenczi reproached Freud for not having analyzed the negative aspects of his transference onto him, Freud’s response included the following: “A certain man, who had himself practised analysis with great success, came to the conclusion that his relations both to men and women . . . were nevertheless not free from neurotic impediments; and he therefore made himself the subject of an analysis by someone else whom he regarded as superior to himself. This critical

illumination of his own self had a completely successful result. . . . But then . . . trouble arose. The man who had been analysed became antagonistic to the analyst and reproached him for having failed to give him a complete analysis. The analyst, he said, ought to have . . . given his attention to the possibilities of a negative transference. The analyst defended himself by saying that, at the time of the analysis, there was no sign of a negative transference” (p. 221).

The notion of negative transference must be distinguished from that of “negative therapeutic reaction,” which refers to a paradoxical aggravation of symptoms after an interpretation to alleviate them. Even though the upshot of a negative transference may be a negative therapeutic reaction, the appearance of such a reaction does not necessarily imply negative transference, and the analyst may in fact contribute to this by his counter-transference or by the timing, form, or tone of his interpretations.

PAUL DENIS

*See also:* Counter-transference; Negative therapeutic reaction; Transference.

### **Bibliography**

- Freud, Sigmund. (1912b). The dynamics of transference. *SE*, 12: 97–108.
- . (1920a). The psychogenesis of a case of female homosexuality. *SE*, 18: 145–172.
- . (1937c). Analysis terminable and interminable. *SE*, 23: 209–253.
- . (1940a [1938]). An outline of psycho-analysis. *SE*, 23: 139–207.
- Freud, Sigmund, and Breuer, Josef. (1895d). Studies on hysteria. *SE*, 2: 48–106.
- Greenson, Ralph R. (1967). The technique and practice of psychoanalysis. New York: International Universities Press.
- Klein, Melanie. (1975). Some theoretical conclusions regarding the emotional life of the infant. In *The writings of Melanie Klein* (Vol. 4). London: Hogarth. (Original work published 1952)

### **Further Reading**

- Chertoff, Judith M. (1989). Negative oedipal transference male pt. female analyst: Terminat. *Journal of the American Psychoanalytic Association*, 37, 687–714.

Novick, Jack. (1980). Negative therapeutic motivation and negative therapeutic alliance. *Psychoanalytic Study of the Child*, 35, 299–320.

## NEGATIVE, WORK OF THE

Contemporary psychoanalytic theory generally uses the term *negative* in its adjectival form (“negative transference,” “negative therapeutic reaction”). Here it is conceptually treated as a substantive. The “work of the negative” is an expression drawn from Georg Wilhelm Friedrich Hegel (1770–1831), but its application in psychoanalysis is only remotely connected with Hegelian philosophy, except through the work of Jacques Lacan, who quickly dissociated himself from such a connection.

Freud, in his metapsychology, makes implicit use of the negative. The unconscious, for example, does not simply describe what is not conscious, but designates an organization of the psychic apparatus. Later Freud abandoned the unconscious as an agency and replaced it with the id to emphasize that everything we might know of this agency was defined only negatively in relation to the ego. However, the negative is more directly perceptible in what concerns object loss and the work of mourning. In the early stages of Freudian theory, it was just such a structural relation that defined neurosis as the “negative of perversion.” More generally, the idea of representation can also be understood from this viewpoint, in comparison with perception. Representation implies the absence of an object from immediate perception; the object was once perceived but no longer needs to be present to the senses in order to be once again accessible to the mind. Moreover, repression, which keeps consciousness at a distance, can only reinforce the repercussions of the psychic reality while making them ineffable. Even the concept of identification, when contrasted with desire, can be included among the meanings of the negative. These remarks should suffice to weaken the idea of the negative as limited to the pathological and to show that very general concepts of mental life, normal and pathological, can be productively interpreted from the negative viewpoint.

The role played by the destructive drives in Freud’s final theory of the drives is no less productive a site for exploring the work of the negative, particularly when it is framed in terms of how the psyche is undermined by the repetition compulsion, the maintenance of

infantile conflicts, or the nonresolution of the transference neurosis. The last development takes the form of a “relation of non-relation,” and all these developments play their parts in the negative therapeutic reaction. This negative tendency in Freud’s thought is accentuated by his adherence to the concept of the death drive and by his references to masochism as the origin of other psychopathologies.

It is significant that Freud’s article “Negation” (1925h) begins with the use of language in the clinical setting, goes on to argue that negation operates as an intellectual substitute for the repressed, and ends with reference to the oldest instinctual impulses, of which the prototypes, swallowing and spitting, are considered the roots of affirmation and negation. Freud then closes his discussion by evoking the negativism displayed in some cases of psychosis.

André Green has proposed bringing together some of the defense mechanisms discussed by Freud: the prototypical defense of repression, which yet has its own character (Freud designated it first and foremost as having the function of preventing the appearance of displeasure, and so gave it a privileged position with regard to affect, although it is more readily recognizable with respect to representation); splitting or disavowal, which, according to Freud, bears more specifically on perception; foreclosure, which radically rejects the expression of the drives to the point where it is difficult to discern the different modes of representation; and finally, negation, which is essentially involved in the structuring of language and thus is not limited to the pathological but extends as well to the cultural. Green argued for combining these different forms of defense and understanding them as fundamental indices of the work of the negative. They all carry with them the obligation of a yes-or-no decision. Eventually, other defenses might be added to this list, for instance Melanie Klein’s projective identification, but this grouping permits one to grasp their coherence, to see the common ground in the clinical treatment of the neuroses and nonneurotic psychic structures, and to examine the modalities of their articulation.

The structural organization of splitting, disavowal, and foreclosure have been most frequently accounted for by conceiving destructiveness as echoing those difficult-to-discern vicissitudes of libido. In this vein, the negative has contributed to a reinterpretation of the controversial death drive. In this theoretical work, narcissism is a key concept. Green proposed reconsi-

dering narcissism as “negative narcissism,” where the psyche aspires toward its own destruction after the failure of other solutions. Negative narcissism is a process that tends not toward the One, as narcissism does in its Freudian version, but toward nothing. The negative must be understood here not as the inverse of the positive, but as a return to nothing. This interpretation allows a better understanding of certain aspects of contemporary clinical practice: empty states and deactivation; futility and nonengagement; Pierre Marty’s “essential depression”; the impairment of basic drives in eating disorders, suicidal behaviors, and addictions—phenomena that are poorly illuminated by existing theories. While these states are offered here as examples of the concepts presented, the field of the negative is far from limited to them. In corresponding fashion, this approach of deploying the negative might also permit better articulation between the theory of the drives and the theory of object relations.

A fundamental function of psychic life consists in the transformation of drive into object. In other words, object relations cannot be limited to transformations of existing internal and external objects, but must also involve the capacity of the psyche to create objects from the drives and thus contribute to the complexity of psychic investment. This is what Green has called “the objectifying function.” Conversely, the activity of the destructive drives does not limit itself to patent destructiveness, but also operates to deobjectify, or undo prior objectification. When the destructive drive deobjectifies a given object, it seeks to renounce whatever is unique or irreplaceable about that object for the subject.

The application of these ideas has permitted a reconsideration of how narcissism obscures alterity (or alienation) and in this way plays a part in primary masochism and negative reactions to therapy. They have also revealed how splitting has privileged application in the negative states of disengagement and indifference frequently found in borderline cases.

The negative has particularly important application with respect to hallucination. Hallucination is at the base of a primary hypothesis on psychic functioning: the hallucinatory realization of desire that connects dreams and hallucination. Negative hallucination, which was so often found in the early texts of psychoanalysis but subsequently disappeared from Freud’s writing, reveals itself to be a heuristically rich concept for comprehending certain regressive functioning

involving a hallucinatory mode, rather than hallucination itself.

Green’s is not the only work in contemporary psychoanalytic theory to attend to the negative. One can find an intuition of the negative in Winnicott’s late work on objects and transitional phenomena. In another way and from a different inspiration, a similar intuition can be said to shape Bion’s distinction between the “no-thing” and the nothing. These refer to representation and absence, respectively, while the reference to nothingness, or inexistence, could be understood as the result of a projective identification.

ANDRÉ GREEN

*See also:* Absence; Anality; “Analysis Terminable and Interminable”; Antinarcissism; Dead mother complex; Death instinct (Thanatos); “Negation”; Negative hallucination; Paradox; Suffering; Work (as a psychoanalytic notion).

### **Bibliography**

Freud, Sigmund. (1925h). Negation. *SE*, 19: 233–239.

Green, André. (1999). *The work of the negative* (Andrew Weller, Trans.). London: Free Association, 1999. (Original work published 1993)

---

## **NEOPSYCHOANALYSIS**

In stages, Harald Schultz-Hencke developed a psychological theory that in 1945 became known as *neops psychoanalysis*. His idea was to create a successful, more scientific amalgamation of the three “historical trends” in research (Sigmund Freud, Alfred Adler, and Carl Gustav Jung).

In *Einführung in die Psychoanalyse* (Introduction to psychoanalysis; 1927) Schultz-Hencke posited that psychoanalysis could be conceived in terms of descriptive psychology. Between 1928 and 1931 he attempted, in accordance with his empirical positions, to dissociate the supposed “facts” of psychoanalytic discovery from the “theoretical scaffolding,” in order to reject the most important theoretical concepts one by one (in particular, metapsychology, libidinal theory, the Oedipus complex, and the unconscious). In addition, beginning in 1929 he tried to integrate into his “amalgamation” those empirical elements of the theories of Adler, Jung, and Freud that seemed certain to him. In this he was influenced by the then-dominant currents within the

Allgemeine Ärztliche Gesellschaft für Psychotherapie (General society of psychotherapeutic medicine): “eclectic psychoanalysis” (Wilhelm Stekel, Walter Schindler) and by attempts to establish a unified medical psychoanalysis (cf. Johannes Heinrich-Schultz).

In *Der gehemmte Mensch* (Inhibited man; 1940) he conceptualized his theory of the neuroses as *Desmolyse* (from *desmos*, meaning “chain”), in accordance with his belief that the inhibition of expansivity constituted the essence of all neurotic development. In 1945 he named his conception *Neopsychoanalyse*, and from that year until 1952 he made various attempts to present it as “modern psychoanalysis,” “psychosomatics” (Franz Alexander), or as a specialty within psychiatry.

The psychoanalytic theory of the instincts was replaced, in Schultz-Hencke’s model, by a more conventional doctrine of psychological impulses (*Antrieblehre*), in which independent impulses are distinguished: autochthonous; intentional lived impulses, such as the grasping (oral), retentive (anal), aggressive, self-esteem, and urethral impulses; and finally, the lived impulse of love (sexual impulse). The nodal process of the formation of neuroses is similar to inhibition; neurotic symptomatology does not result from an old intrapsychic conflict, but instead functions like an embedded “piece of shrapnel” from a former integral life experience, and the corresponding etiological factors stem from an upbringing that has been either overly rigorous or overly lax. In this regard the implicit theoretical model of neopsychoanalysis is similar to behaviorist theory, making it superior, in the view of some of Schultz-Hencke’s followers, to classical psychoanalysis.

In terms of technique, the goal is to stress amnesia (recollection), leading to different treatment indications depending on the depth of the neurosis: Short-term therapy may be recommended. Emphasis is placed on current reality: evaluating the work of therapy, skepticism with regard to interpretations, and giving up the transference and countertransference. In many respects it is a conventional medical model that involves applying a treatment method according to prescribed rules with the aim of curing an illness. Schultz-Hencke’s essentially descriptive theory of the neuroses was propagated and vulgarized by Fritz Riemann in *Grundformen der Angst* (Primitive forms of anxiety; 1966). Neopsychoanalytic treatment technique was developed by Annemarie Dührssen and Helmut Bach, among others. Werner Schwidder used and further developed Schultz-Hencke’s psychosomatic theory.

In 1960 German neopsychoanalysts (of the Deutsche Psychoanalytische Gesellschaft [DPG, German Psychoanalytic Society]) became affiliated with the International Federation of Psychoanalytic Societies; founding members of this international forum included Walter Schindler, René Laforgue, Erick Fromm, Karen Horney, and Franz Alexander. Setting aside internal theoretical divergences, this movement was originally intended to be a “progressive” alternative to the International Psychoanalytical Association and aimed to take positions distinct from those of “orthodox” psychoanalysis. But international intellectual exchanges, above all in the area of ego psychology, produced a shift that ended up making Schultz-Hencke’s neopsychoanalysis superfluous, because within the spectrum of internationally recognized trends, a number of elements of neopsychoanalysis gradually emerged and were reworked, without needing to be identified with Schultz-Hencke’s name to lend them weight.

IRMA GLEISS

*See also:* Germany; Deutsches Institut für Psychologische Forschung und Psychotherapie (Institut Göring); *Psyche. Zeitschrift für Psychanalyse und ihre Anwendungen*; Schultz-Hencke, Harald Julius Alfred Carl-Ludwig; Splits in psychoanalysis.

### Bibliography

- Bach, Helmut. (1970). Die Behandlungstechnik in den neopsychoanalytischen Richtungen. In *Lerbuch der Klinischen Psychologie* (W. J. Schraml, Ed.). Bern: Hans Huber.
- Heigl, Franz, and Axel, Triebel. (1977). *Lernvorgänge in psychoanalytischer therapie*. Bern: Hans Huber.
- Riemann, Fritz. (1966). *Grundformen der Angst*. Munich and Basel: Ernst Reinhardt.
- Schulz-Hencke, Harald. (1972). *Einführung in die psychoanalyse*. Jena-Göttinger: Fischer-Vandenhoeck and Ruprecht. (Original work published 1927)
- . (1982). *Der gehemmte mensch*. Leipzig and Stuttgart: Thieme. (Original work published 1940)

---

## NERVOUS ANXIETY STATES AND THEIR TREATMENT

This book, for which Sigmund Freud wrote a foreword, was a compromise between Wilhelm Stekel’s

view, that all neuroses were rooted in a psychological conflict, and the position of Freud, that anxiety states were caused by the toxic effect of supposed sexual missteps. The contents were discussed by Stekel with Freud in a series of weekly meetings during 1907–1908; Stekel persuaded his mentor that at least some anxiety states had a psychological etiology and for such cases Freud proposed the term “anxiety hysteria.”

The first part of the book, on anxiety neuroses, presents a large amount of case material indicating the successful treatment of a number of anxiety equivalents through the removal of the sexual mispractice. The second part, which deals in a similar way with different forms of anxiety hysteria, has an introductory section by Freud himself (acknowledged only in the third and fourth editions). A third part includes chapters on the diagnosis and therapy of anxiety states, and on the technique of psychotherapy. There it is revealed that Stekel has given up using the couch, and is sitting beside his patients at a desk.

The second and subsequent editions of the book, which appeared in 1912, 1921, and 1924, formed the first of a ten-volume work, *Störungen des Trieb- und Affektlebens*. Over the course of these volumes, Stekel increasingly distanced himself from Freud. The latter's rather lukewarm foreword was dropped in later editions.

The main characteristic of this book is its abundance of fascinating case material. Unlike Freud, who was inclined to theorize on the basis of paradigm cases, Stekel presented as much material as possible and was inclined to avoid “sterile theoretical considerations.” (Stekel, 1908, p. 180) The book includes much medial detail, particularly in the chapter on therapy where the use of opium and bromide are discussed. Both Eugen Bleuler and Carl Gustav Jung reviewed the book favorably. The fact that Arthur Schnitzler read it is some pointer to its impact.

FRANCES CLARK-LOWES

See also: Stekel, Wilhelm.

### Source Citations

Stekel, Wilhelm. (1908). *Nervöse Angstzustände und ihre Behandlung*. Berlin-Wien: Urban and Schwarzenberg.

Freud, Sigmund. (1908). Preface: Stekel's “Nervous anxiety-states and their treatment.” *SE*, 9: 250–251.

### Bibliography

Bleuler, Eugen. (1908). Dr Wilhelm Stekel, spezialarzt für psychotherapie in Wien: nervöse angstzustände und ihre behandlung. *Münchner medizinische Wochenschrift*, 32, 1702–1703.

Jung, Carl Gustav. (1908b). Review of W. Stekel: “Nervöse angstzustände und ihre behandlung.” In *Collected Works*, t. 18. London: Routledge and Kegan Paul.

Stekel, Wilhelm. (1907). *Die ursachen der nervosität. Neue ansichten über deren entstehung und verhütung*. Vienna: Knepler.

———. (1950). *The autobiography of Wilhelm Stekel. The life story of a pioneer psychoanalyst*. New York: Liveright.

---

## NETHERLANDS

Interest in psychoanalysis within Holland developed from 1905 onward and came from three different sources. The first source consisted of psychiatrists who were struck by Freud's studies on dreams. August Stärcke corresponded with Freud and J. van Emden had an analysis with him during a holiday in Karlsbad in 1911. Both became members of the Viennese Society in 1911. The second source came from psychiatrists who went to Jung in Zürich for analysis between 1911 and 1913. The third source was Leiden University. Jelgersma's rectorial address in 1914 at Leiden University was the first official recognition of psychoanalytic science in Europe. Thirteen representatives of these three groups, Freudians, Jungians and theoretical university analysts, founded the Dutch Society of Psychoanalysis on March 24, 1917. It was the seventh branch society of the International Psychoanalytical Association (IPA), formed with the goal of supporting the development of psychoanalysis according to Sigmund Freud. The Sixth IPA Congress took place in The Hague in 1920, chosen (because of Dutch neutrality during World War I) to facilitate the reunion of analysts who had been territorial enemies.

After that, however, there followed a period of quarreling and lessened productivity, which was partly due to the diversity of the members. The main points of controversy were the question of lay analysis—until 1938 only medical doctors were admitted—and the introduction of the tripartite training system, especially the obligation of personal analysis, introduced by Max Eitingon and Hanns Sachs in 1925 for all IPA

branch societies. The conflict was mainly between the Society's president, Van Ophuijsen, who defended both lay analysis and the tripartite training model (he was treasurer and later vice-president of the IPA), and the theoretically-oriented psychiatrists of the university and Van Ophuijsen's former analysts Westerman Holstijn. The conflicts escalated and led to a split when in 1933 four Jewish analysts emigrated from Germany to Holland: Karl Landauer, Theodor Reik, Levy-Sühl and Watermann. The poorly-trained Dutch analysts, with lesser income from analytic practice, felt threatened by the arrival of four more competent analysts. A few expressed their panic in open anti-Semitism. Most were not anti-Semitic but refused to accept the refugees as members of the Society. Van Ophuijsen, however, saw a possibility to improve the quality of psychoanalysis in Holland with the help of the refugees and arranged Landauer's participation in his psychoanalytic institute (founded in 1930 in The Hague). In the resulting uproar by the members Van Ophuijsen resigned as president and member and founded, with Van Emden, Maurits Katan and a few others, a new society, the Society of Psychoanalysts in the Netherlands, of which the German immigrants became members. In the years to come the diplomatic analyst Westerman Holstijn put much energy in the reconciliation of the two societies, which succeeded in 1937. However, he himself resigned as a member, badly hurt by the lack of appreciation of his colleagues.

In 1938, after the Anschluss of Austria, Jeanne Lampl-de Groot and Hans Lampl came from Vienna to Amsterdam. Jeanne de Groot, a Dutch psychiatrist, had gone to Vienna in 1923 for analytic training with Freud and in 1925, after her marriage with Hans Lampl, to Berlin. In 1933 they had returned to Vienna. In Holland they started to reform the training program according to Viennese standards in cooperation with the members Le Coultre and Maurits Katan. Both the tripartite training model and lay analysis were accepted.

In May 1940 Holland was occupied by the Germans. When in November 1940 Jews had to resign as society members by German law, the non-Jewish psychoanalysts resigned as well in an act of solidarity and the Society virtually ceased to exist. Psychoanalytic training was organized underground with only two analysts functioning: Jeanne Lampl-deGroot and Le Coultre. In November 1945 the Society was refounded.

In 1946 some members founded the Psychoanalytical Institute (PAI), an ambulatorium where patients could come for psychoanalytic treatment at limited cost by candidates who earned a small fee. The house of the PAI became and as of 2005, still is the center of training, where, among other things, seminars are held and scientific meetings organized.

In 1947 Westerman Holstijn and Van der Hoop, who both had left the Society in discontent, founded with others the Dutch Psychoanalytical Association. Initially, the Association was meant to be a forum where one could discuss psychoanalysis in a free atmosphere without the stress of training. Soon, however, a training program was organized, though with much milder requirements than those of the Society. Training analyses were performed at low frequency and for a short period. During the first twenty-five or thirty years of its existence, the relationship between Society and Association varied from non-existent to very bad. Three successive presidents of the Association; Jan Groen, Poslavsky, and Stufkens, managed to raise the quality of training gradually to IPA level, coinciding with a much more friendly cooperation with the Society. The societies share an increasing number of mutual members. In 1983 the Association founded its own institute in Utrecht, the PIU. The psychoanalytic institutes of Society and Association fused into the Dutch Psychoanalytic Institute (NPI) in 1995, which serves the candidates of both societies. It is expected that the Association will be a component society of the IPA in the near future.

From 1945 until roughly 1970 psychoanalysis blossomed in Holland. The number of candidates steadily increased; there were more patients for analysis than could be treated; there was an active scientific life. Three IPA congresses were organized in Amsterdam, in 1951, 1965 and 1993. Van der Leeuw became vice-president of the IPA in 1963 and president from 1965–1969. Montessori was secretary from 1965–1969 and vice-president after that until 1975. Lampl-deGroot was honorary vice-president from 1963 until her death in 1987. Several Dutch held an office in the European Psychoanalytical Federation: Thiel and Dalewijk as vice-president, Mekking as treasurer, and Groen-Prakken as president.

In 1966 a child-analytic training was organized within the Society by Teuns, with great support of especially Frijling-Schreuder through many years to come. Teachers from the Hampstead clinic came to



Leiden or Amsterdam for theoretical and technical seminars and supervision. Also in 1966 the government decided to subsidize psychoanalytical treatments as far as the patient could not afford the treatment himself. In 1980 therapies at the Institutes for mental health, including the analytic Institutes, became virtually free from payment. The important chairs in psychiatry, child psychiatry and clinical psychology at the universities were mainly occupied by psychoanalysts.

Over the course of the 1980s there was a decline in interest in psychoanalysis, as in most western communities. In Holland, the growing grip of the authorities on psychoanalytic practice, the near-disappearance of private practice, and the replacement of psychoanalytically-oriented university teachers by biologically oriented ones were important factors. The same period, however, saw a mounting interest in the application of psychoanalysis to other fields. In 1979 the analytic societies founded together the Dutch Society for Psychoanalytic Psychotherapy and in 1989 the Foundation for Psychoanalysis and Culture was established, by the analysts Baneke and De Jong and the scientists in literature Schönau and Hillenaar, to connect psychoanalytical with general cultural experience. The annual workshops, organized by the Association, to introduce modern analytic views to a wide audience of psychotherapists are always overbooked.

Traditionally, the Dutch have been tradesmen for many centuries. They played an active role also in the export of psychoanalytic knowledge to Germany in the first period after the war, and in the late twentieth century to some former Soviet satellite countries: Prague first, and from 1994 onward, to Romania and Lithuania, where regular seminars are organized.

Four main scientific threads have developed, mostly after 1945. From the predominantly ego-psychological orientation after 1938 a continuous trend emerged to integrate drive- and ego- psychology with observations on narcissistic development and pathology (Lampl-de Groot, Le Coultre, Van der Leeuw, Spanjaard, Treurniet). Many analysts from before the war already came from Child Guidance Clinics. The direct observation and treatment of neurotic and psychotic children has led to a mutual influence of adult and child psychoanalysis and to the use of psychoanalytical approaches in prevention of childhood disorders (Frijling-Schreuder, Kamp, Van Waning). The Dutch training

programs are founded upon integrated child and adult theoretical seminars. In the third place there was and is a vivid exchange between psychoanalysis and the adult psychiatric clinic (Kuiper, De Blécourt, Van Tilburg). The fourth mainstream is centered around the aftermath of war in the first, second, and the contemporary generation (Keilson, De Wind, Jacques Tas, Louis Tas, De Levita, Bruggeman). Among the solitary theoreticians in the widened scope of psychoanalysis, De Jonghe, Ladan, Stufkens, and Bögels should be mentioned.

Regularly, textbooks and analytic books on a specific topic are published in Dutch. In 1978 Keilson published his long-term investigation on Jewish war orphans in Germany, *Sequentielle Traumatisierung bei Kindern* (now translated into English). In 1985 the collected papers by Lampl-de Groot were published in English titled *Man and Mind*. In 1991 Halberstadt-Freud published *Freud, Proust, Perversion and Love*. In 1993, at the thirty-eighth IPA congress in Amsterdam, *Dutch Art and Character, a Psychoanalytic View* was edited by Baneke and others. In 1993 and 1995 two volumes of the *Dutch Annual of Psychoanalysis* appeared, edited by Ladan, Groen-Prakken, and Stufkens, and in 1996, on the occasion of a celebration of Treurniet, *Psychoanalysis in a Post-Classical Context* was published, edited by Groen-Prakken and featuring Treurniet's article "On an Ethic of Psychoanalytic Technique," alongside papers by foreign and Dutch friends.

HAN GROEN-PRAKKEN

### Bibliography

- Brinkgreve, Christien. (1984). *Psychoanalyse in Nederland. Een vestigingsstrijd*. Amsterdam: Arbeiderspers.
- Bulhof, Ilse N. (1983). *Freud en Nederland*. Baarn: Ambo.
- Freud, Sigmund. (1914d). On the history of the psychoanalytic movement. *SE*, 14: 1–66.
- . (1974a). *The Freud/Jung letters: The correspondence between Sigmund Freud and C. G. Jung* (William McGuire, Ed.; Ralph Manheim and R. F. C. Hull, Trans.). Princeton, N.J: Princeton University Press.
- Groen-Prakken, Han. (1993). The psychoanalytical society and the analyst, with special reference to the history of the Dutch Psychoanalytical Society 1917–1947. In *Dutch Annual of Psychoanalysis, 1993* (p. 13–37). Amsterdam-Lisse: Swets and Zeitlinger.

## NEURASTHENIA

The term *neurasthenia* was coined in English by the American psychiatrist George Beard (1839–1883) to describe an illness characterized by its etiology and its clinical manifestations; it appeared in Beard’s *Neurasthenia As a Cause of Inebriety* (1879) and *Sexual Neurasthenia (Nervous Exhaustion), Its Hygiene, Causes, Symptoms and Treatment* (1884). Sigmund Freud retained the word, although he gave it a more limited meaning, and included it among the defense neuroses, alongside anxiety neurosis and, later, hypochondria.

In Beard’s work, neurasthenia is characterized by the appearance, in subjects who had no family or personal history suggesting mental degeneration, and who, men and women alike, had previously lived the active life of “managers” peculiar to the feverish lifestyle of the New World, of a chronic symptomatology that was both somatic and mental. Somatic symptoms included fatigue that is not alleviated by rest, cephalgias with constriction, back pains, dyspepsia, flatulence, constipation, and dysurea; mental symptoms included insomnia, sadness, lack of interest, anhedonia, impoverishment of sexual activity that had previously been satisfying, and morosity. He attributed this neurasthenia to an excess of activity by those who, in the brutal world of business, must expend an excessive daily energy, and he thus contrasted it to the spleen and melancholia of idlers. As early as 1879, Beard stigmatized alcohol use as a fallacious remedy to this condition, and one that could lead to a secondary pathology.

In Freud’s view, expressed in “On the Grounds for Detaching a Particular Syndrome from Neurasthenia under the Description ‘Anxiety Neurosis,’” Beard’s clinical description was too general and the etiology was imprecise, but it was appropriate to keep the term in medical terminology, on the condition that its semiology be restricted and its origins specified. He retained physical fatigue, somatic disorders, and the impoverishment of sexual life (in particular masturbation that fails to resolve libidinal tension) as neurasthenic symptoms, but he excluded chronic states of anxious expectation and acute anxiety attacks (sometimes with a substantial somatic component), which he held to be typical of “anxiety neurosis.” From an etiological point of view, neurasthenia is a defense neurosis whose symptomatology is not a symbolic and

overdetermined expression, and whose etiology must be sought not in childhood conflicts, but rather in a present frustration.

GEORGES LANTÉRI-LAURA

*See also:* Actual; Actual neurosis/defense neurosis; Conversion; “Heredity and the Aetiology of the Neuroses”; “Neurasthenia and ‘Anxiety Neurosis’”; Traumatic neurosis; United States.

### Bibliography

- Beard, George. (1879). *Neurasthenia as a cause of inebriety*. New York: E. B. Treat.
- . (1881). *American nervousness: Its causes and consequences*. New York: E. B. Treat.
- . (1884). *Sexual neurasthenia (nervous exhaustion), its hygiene, causes, symptoms and treatment*. New York: E. B. Treat.
- Freud, Sigmund. (1895b [1894]). On the grounds for detaching a particular syndrome from neurasthenia under the description “anxiety neurosis.” *SE*, 3: 85–115.
- Pichot, Pierre. (1994). La neurasthénie. *Encéphale*, 20 (3), 540–550.

## “NEURASTHENIA AND ‘ANXIETY NEUROSIS’ ”

Written around June 1894 and published on January 15, 1895, after it had been read by Josef Breuer, the article “On the Grounds for Detaching a Particular Syndrome from Neurasthenia under the Description ‘Anxiety Neurosis’ ” earned Freud considerable recognition, for the syndrome that he isolated in it was discussed at length at neuropsychiatric congresses in the early twentieth century.

Freud’s correspondence with Wilhelm Fliess reveals the extent to which the problem of neurasthenia preoccupied the two men: They had decided to undertake a major joint study of this topic, though it was never published. As early as 1892, Freud wrote in Manuscript A, “No neurasthenia or analogous neurosis exists without a disturbance of the sexual function” (1950a [1887–1902], p. 178). In fact, what separated anxiety neurosis (*Angstneurose*) from George Beard’s broad, all-purpose category of neurasthenia was essentially the thesis of a sexual etiology (very common, according to Freud), which he presented in the 1895 article.

Freud began his article with a description of the syndrome itself: a general susceptibility to stimuli (especially auditory ones), chronic states of anxious expectation, excessive moral scruples, and the well-known somatic problems associated with anxiety attacks (such as dizziness, night terrors, animal phobias, and agoraphobia). It did not, however, involve repressed ideas. Freud also distinguished anxiety neurosis from a simple anxiety attack, which he still conceptualized on a biological model that he abandoned only later.

In the next part of the article, Freud examined the etiology and occurrence of anxiety neurosis. Its onset, Freud noted, comes in the form of virginal anxiety (he referred to it in connection with Katharina in *Studies in Hysteria*, published that same year), or in newlyweds or in those practicing abstinence or coitus interruptus. It results from an accumulation and a “deflection of somatic sexual excitation,” together with a deficiency in mental participation, which would normally discharge in “adequate action” (1895b [1894], p. 108).

In the third section, titled “First Steps towards a Theory of Anxiety Neurosis,” Freud explains that the mind experiences anxiety when it is unable to face an external danger, and anxiety neurosis when the source of sexual excitation is internal.

In the fourth and concluding section, titled “Relationship to Other Neuroses,” Freud hypothesized that anxiety neurosis is the “somatic counterpart to hysteria” (1895b [1894], p. 115), which is provoked by psychic conflict. While anxiety neurosis and neurasthenia have a common somatic origin, they are different in that neurasthenia comes from an impoverishment of excitation, whereas anxiety neurosis is linked to its accumulation.

Although the birth and development of these ideas can be traced over the course of Freud’s correspondence with Fliess, the 1895 article on anxiety neurosis, published a few months before *Studies on Hysteria* (1895d), was their first public expression.

Following publication of the paper, Freud was very upset by the criticism of a Munich psychiatrist, Leopold Löwenfeld, whom he held in esteem. “What I must contest,” wrote Löwenfeld, “is only the regularity and specificity of the sexual etiology posited by Freud in ‘acquired’ anxiety states.” This immediately occasioned one of Freud’s rare polemical responses,

“A Reply to Criticisms of My Paper on Anxiety Neurosis” (1895f), in which he specified that “anxiety neurosis is caused by everything that keeps somatic sexual tension away from the psychical sphere, which interferes with its being worked over psychically” (p. 124), adding that “the neuroses are overdetermined” (p. 131). He also noted the distinctions that needed to be established among the conditions of a syndrome (here, heredity), its specific causes (here, sexual etiology), its auxiliary causes, and its triggers.

“I am pretty well alone here in tackling the neuroses. They regard me rather as a monomaniac, while I have the distinct feeling that I have touched on one of the great secrets of nature,” Freud wrote to Fliess on May 21, 1894 (1954, p. 83). Indeed, most commentators in the decades to come accepted Freud’s isolation of anxiety neurosis, but its sexual etiology, which Freud consistently made a condition, continued to be challenged.

Meanwhile, the idea of anxiety neurosis continued to circulate and drew support from an 1897 study by Felix Gattel involving about a hundred cases observed in Richard vonKrafft-Ebing’s psychiatric clinic in Vienna. Several French authors, alerted by a review of Freud’s article published in the *Revue neurologique* (vol. 3) in 1895, discussed anxiety neurosis, and their views were included by Paul Hartenberg in *La névrose d’angoisse* (Anxiety neurosis; 1902). Hartenberg concluded, “The ideas of Freud and some other authors on the sexual origin of the neuroses are far from being accepted by the majority of doctors, especially in France. And no doubt many practitioners would refuse to accept an etiology that is so exclusive. Thus, by introducing these restrictions, it seems to me that I have fostered the success of anxiety neurosis. By recognizing that it has a more general etiology, which includes overwork and exhaustion of the organic [that is, the biological], I am presenting it under a more easily acceptable physiognomy.” Charles Féré, Joseph Capgras, Gilbert Ballet, A. Cullère, and numerous other authors followed this same route.

In April 1907 Wilhelm Stekel (who in 1908 would publish *Nervöse Angstzustände und ihre Behandlung* [*Conditions of Nervous Anxiety and Their Treatment*; 1923]) delivered a lecture entitled “Psychology and Pathology of Anxiety Neurosis” to the Vienna Psychoanalytic Society. In it Stekel said that contrary to the opinion of Freud, according to whom “anxiety neurosis is provoked by coitus interruptus” and who saw

“the source of anxiety in the fact that somatic sexual excitation is diverted from the psyche,” he (Stekel) “remains convinced that in anxiety neurosis—as in all neuroses—psychic conflict is essential” (Nunberg and Federn, 1962–1975). Alfred Adler, for his part, then suggested that anxiety neuroses are found in anyone manifesting psychic weaknesses.

In his response of February 16, 1908, to a question from Karl Abraham, Freud distanced himself somewhat from what he had written thirteen years earlier: “As for the reducibility of the anxiety in anxiety neurosis, you will find full information in Stekel’s book on anxiety hysteria (expected in April). I myself still regard the old position as theoretically unassailable, but I see that pure cases of anxiety neurosis are great rarities and perhaps once again only abstractions, and that the not actually typical phobias permit and call for psycho-analytic resolution. I ‘fancy’ there is nearly always an element of hysteria in them. In practice what happens is that actual therapy is first attempted, and resort is then had to psycho-analytic therapy to deal with what turns out to be resistant” (Freud and Abraham, 1965, p. 26).

Discussion increasingly shifted toward hysterical anxiety, and this shift went hand in hand with diminished interest in the notion of “actual [anxiety] neurosis,” except by Sándor Ferenczi and Freud, who continued to focus on it. According to Paul Federn’s (1933) memories of Ferenczi, Freud confided to Ferenczi his belief that hypochondria was a narcissistic actual neurosis with an excessive libidinal cathexis of the affected organ. This opinion was later taken up by Otto Fenichel (1945). In addition, several American authors (Grete Bibring, Abram Blau, Leo Rangell, Angela Richards, and Elizabeth Zetzel, among others) found correlations between anxiety neurosis and some sexual conditions reported in Masters and Johnson (Fink, 1970). Investigators of psychosomatic disorders (Pierre Marty, Joyce MacDougall) also made sure to refer to anxiety neurosis.

In *A Phylogenetic Fantasy* (1985 [1915]), according to Peter Gay’s account in *Freud: A Life for Our Time* (1988), Freud speculated, “Anxiety hysteria might prove to be a legacy from the ice age, when early mankind, threatened by the great freeze, had converted libido into anxiety. This state of terror must have generated the thought that in such a chilling environment, biological reproduction is the enemy of self-

preservation, and primitive efforts at birth control must in turn have produced hysteria” (1988, p. 368).

Freud elaborated several theories of “anxiety,” properly speaking, the last of these in *Inhibitions, Symptoms, and Anxiety* (1926).

ALAIN DE MIJOLLA

See also: Disorganization; Neurasthenia; Working-through.

### Source Citation

Freud, Sigmund. (1895b [1894]). Über die Berechtigung, von der Neurasthenie einen bestimmten Symptomenkomplex als “Angst-Neurose” abzutrennen. *Neurol. Zbl.*, XIV, p. 50–66; *G.W.*, I, p. 315–342; On the grounds for detaching a particular syndrome from neurasthenia under the description “anxiety neurosis.” *SE*, 3: 85–115.

### Bibliography

- Blau, Abram. (1952). In support of Freud’s syndrome of “actual” anxiety (actual) neurosis. *International Journal of Psycho-Analysis*, 33, 363–372.
- Federn, Paul. (1933). Sándor Ferenczi. *International Journal of Psycho-Analysis*, 14, 467.
- Fenichel, Otto. (1945). *The psychoanalytic theory of neurosis*. New York: W. W. Norton.
- Fink, Paul. (1970). Correlation between “actual” neurosis and Masters and Johnson. *Psychoanalytic Quarterly*, 39, 38–51.
- Freud, Sigmund. (1895f). A reply to criticisms of my paper on anxiety neurosis. *SE*, 3: 118–139.
- . (1926d [1925]). Inhibitions, symptoms, and anxiety. *SE*, 20: 75–172.
- . (1950a [1887–1902]). Extracts from the Fliess Papers. *SE*, 1: 173–280.
- . (1954). *The origins of psychoanalysis: Letters to Wilhelm Fliess, drafts, and notes, 1887–1902* (Marie Bonaparte, Anna Freud, Ernst Kris, Eds.). London: Imago Publishing.
- . (1985 [1915]). *A phylogenetic fantasy: Overview of the transference neuroses* (Axel Hoffer and Peter T. Hoffer, Trans.). Cambridge, MA: Harvard University Press, 1987.
- Freud, Sigmund, and Abraham, Karl. (1965). *A psycho-analytic dialogue: The letters of Sigmund Freud and Karl Abraham, 1907–1926* (Bernard Marsh and Hilda C. Abraham, Trans.). New York: Basic Books.
- Freud, Sigmund, and Breuer, Josef. (1895d). Studies on hysteria. *SE*, 2: 48–106.

- Gay, Peter. (1988). *Freud: A life for our time*. London: Dent.
- Hartenberg, Paul. (1902). *La névrose d'angoisse*. Paris: Félix Alcan.
- Nunberg, Hermann, and Federn, Ernst. (1962–1975). *Minutes of the Vienna Psychoanalytic Society*. New York: International Universities Press.
- Stekel, Wilhelm. (1923). *Conditions of nervous anxiety and their treatment* (Rosalie Gabler, Trans.). New York: Dodd, Mead. (Original work published 1908)

## NEURO-PSYCHOSIS OF DEFENSE

The “neuro-psychosis of defense,” a nosological category identified by Freud in 1894, covers neurotic and psychotic disorders characterized by conflict between affects and ideas: hysteria, obsessions, phobias, and hallucinatory psychoses. Two years later, the notion of the defenses became more central in Freud’s theories (1896b).

In “The Neuro-Psychoses of Defence” (1894a), Freud reported on his “detailed study of a number of nervous patients suffering from phobias and obsessions” (p. 45). He viewed this study as a contribution to “the theory of hysteria, or rather a change in it, which appears to take into account an important characteristic that is common both to hysteria and to the neuroses I have just mentioned” (p. 45). He isolated the defense that is characteristic of hysteria and established possible connections between it and phobias and obsessions. Above all, the article was one of Freud’s earliest discussions of the conflict between affects and ideas and of the consequences such conflict could have in the functioning of the ego.

In “Further Remarks on the Neuro-Psychoses of Defence” (1896b), Freud returned to his discussion of the different forms of neurosis, emphasizing that his observations in the last two years had reinforced his view of “defence as the nuclear point in the psychical mechanism of the neuroses in question” (p. 162)—a view he maintained in his subsequent writings.

At the time Freud wrote these articles, he had not yet entirely worked out his first theory of repression, so his discussion seem essentially descriptive.

ELSA SCHMID-KITSIKIS

*See also:* Actual; Actual neurosis/defense neurosis; Defense; “Heredity and the Aetiology of the Neuroses”; Psychic causality.

## Bibliography

- Freud, Sigmund. (1894a). The neuro-psychoses of defence. *SE*, 3: 41–61.
- . (1896b). Further remarks on the neuro-psychoses of defence. *SE*, 3: 157–185.

## NEUROSIS

For psychoanalysts, neuroses are mental disorders that have no discernible underlying anatomical causes and whose symptomatology arises from intrapsychic conflict between unconscious fantasies bound up with the Oedipus complex and the defenses that these fantasies arouse. Neuroses may be defined in several ways. From a topographical standpoint, they may be defined in terms of a specific differentiation of the ego. From a dynamic standpoint, they may be defined by the ego’s embrace (under the influence of the superego) of the reality principle, to the detriment of the pleasure principle and the id’s instinctual demands, and this leads to the emergence of castration anxiety. From an economic standpoint, they may be defined by a prevalent but partly ineffective mobilization of the mechanisms of repression against the id’s instinctual demands. Finally, from a developmental (or genetic) standpoint, they may be defined by the achievement of a symbolization of intrapsychic conflicts in accord with the oedipal model. This basic neurotic structure is variously associated, in the adult as in the child, with different sets of symptoms (hysterical, phobic, or obsessional).

Nineteenth-century medicine used the terms *neurosis* and *psychasthenia* interchangeably to denote nervous conditions of “functional” origin. It was accepted that the impact of such conditions on the various bodily systems (digestive, cardiopulmonary, urogenital, etc.) was unrelated to any underlying clinical or anatomical factors, and furthermore that there was no major degradation of the subject’s relation to reality. This kind of exclusive diagnosis, purely behavioral and “pre-psychoanalytical,” was revived in the 1990s by some present-day nosologies, among them the fourth edition of the *Diagnostic and Statistical Manual of Mental Disorders (DSM-IV)* and the tenth edition of the World Health Organization’s *International Classification of Diseases (ICD-10)*.

As early as 1894 Freud drew a distinction between two classes of psychopathological phenomena: on the

one hand, the so-called “actual” neuroses, which, in accordance with classical medical theories, he related to a sexual dysfunction contemporaneous with the mental condition (frustration in the case of “anxiety neurosis,” masturbation in the case of “neurasthenia”), and on the other hand, the psychoneuroses of defense, whose cause, he set out to show, was to be found in an intrapsychic conflict of infantile origin.

Only the psychoneuroses, which for a time Freud called “transference neuroses,” correspond to genuine neuroses as Freud definitively described them in 1924: anxiety hysteria (or phobic neurosis), conversion hysteria, and compulsive (or obsessive) neurosis. This clear distinction between the two types of neuroses, though Freud acknowledged that it was sometimes arbitrary, remained essential to his theory. The hypothesis that the origin of the psychoneuroses lies in intrapsychic childhood conflict constitutes, along with dream theory, the theoretical bedrock of psychoanalysis.

The topographical, dynamic, and economic viewpoints, as presented briefly above, have not undergone any serious revision since Freud’s work of 1924. A handful of details aside, all psychoanalytic authors would probably concur with the following formulation from “Neurosis and psychosis”: “The ego has come into conflict with the id in the service of the super-ego and of reality; and this is the state of affairs in every transference neurosis” (1924b [1923], p. 150). In contrast, the “genetic” or developmental standpoint still continues into the twenty-first century to spark endless controversy.

In his rereading of Freud’s case of the “Wolf Man” (1918b [1914]), Jacques Lacan (1988) drew a clear distinction between what he called “foreclosure” (*Verwerfung*) and the concept of repression (*Verdrängung*). Evoking the feminine position assumed by the subject in the oedipal scenario (a position that prohibits the subject, under the threat of castration, from accepting genital reality), Lacan noted, “The *Verwerfung* thus cuts off short any manifestation of the symbolic order” (1988, p. 38). For Lacan, this inability to access the symbolic order differentiates psychosis from neurosis, where there is access to the symbolic order. In his terms, neurotics seek, in a more or less elaborate way, “to introduce into the demand whatever the object of their desire is” and, symmetrically, “to satisfy the demand of the Other by conforming their desire to it.” Because the “Wolf Man” could not place himself

within this oedipal interplay by means of a “deferred” interpretation of the initial scene of seduction, visited upon him at a very early age by his elder sister, he was partially barred from the “chain of signifiers.” In contrast, the phobia of “little Hans” (Freud, 1909b) gave him access to the symbolic order and allowed him to structure his infantile neurosis.

From a quite different perspective, Melanie Klein (beginning in 1930) took up Freud’s metapsychological hypothesis concerning the death instinct. Theorizing that infantile anxiety was directed not against the libido but against the destructive instincts, she developed the notions of the schizophrenic and depressive positions, which created a need to revise the theory of the neuroses. For Klein (1975), the possibility of arriving at the depressive position by acknowledging the presence of the destructive instincts within the personality enabled the subject to access the triangular relations of the Oedipus complex and hence to neurotically organize a personality capable of tolerating loneliness. Working in the same Kleinian theoretical tradition, Hanna Segal (1957) described the transition from symbolic equation (an inability to distinguish between symbols and the objects symbolized) to authentic symbolization. Later Segal (1991) extended the theory still further by considering the conditions of artistic creation and revisiting Freud’s thoughts on sublimation.

Freud proposed the term “narcissistic neurosis” as a designation for manic-depressive psychosis. This suggestion was not adopted by others, but it draws attention to the need to distinguish between manic-depressive psychosis and the other psychoses, in which the nature of the intrapsychic conflict is clearly very different. Jean Bergeret has described as “false neuroses” a number of clinical conditions mentioned by a variety of authors (“failure neurosis,” “abandonment neurosis,” “character neurosis,” “organ neurosis,” and so on) and has proposed a more neutral nomenclature (“failure-prone behavior,” “anaclitic relationship,” and so on). It is true that, in contrast to hysterical neurosis and obsessional-compulsive neurosis, such conditions are not clearly related to the concept of a neurotic structure. Among such false neuroses, the “traumatic” or “war neuroses” occupy a special place in Freud’s metapsychology, for they serve as a point of departure in his development of the hypothesis of a death instinct lying “beyond the ‘pleasure principle’” (1920g). Finally, it should be noted that the classification

*transference neurosis* has come to have a different meaning from what Freud originally assigned to it; it refers to certain phenomena manifesting themselves in the analysand's relationship with the analyst (*transference psychosis* is also used in this way).

The notion of neurosis is also related, of course, to the ideas of *neuroticization* and *infantile neurosis* as mental processes that give access to symbolization. It is in fact such a powerful organizing concept that it has sometimes been taken for an "overall vision of the human being." However, we would do well to remind ourselves of Freud's consistent and deeply negative attitude toward all such overarching visions and the mysticism that invariably accompanies them.

FRANCIS DROSSART

See also: Abandonment; Actual; Actual neurosis/defense neurosis; Amplification (analytical psychology); "Analysis of a Phobia in a Five-year-old Boy (little Hans)"; *Basic Neurosis, The—Oral regression and psychic masochism*; Borderline conditions; Character neurosis; Choice of neurosis; "Claims of Psycho-Analysis to Scientific Interest"; Complex (analytical psychology); Conflict; Developmental disorders; "Dostoyevsky and Parricide"; Failure neurosis; Fate neurosis; Flight into illness; Frustration; *Future of an Illusion, The*; "Heredity and the Aetiology of the Neuroses"; Hysteria; Indications and contraindications for psychoanalysis for an adult; Infantile amnesia; Infantile neurosis; Inferiority, feeling of (individual psychology); *Introductory Lectures on Psychoanalysis*; "Introjection and Transference"; Narcissistic neurosis; Neurasthenia; "Neurasthenia and 'Anxiety Neurosis'"; Neurotica; Neurotic defenses; Nuclear complex; "Splitting of the Ego in the Process of Defence, The"; Obsessional neurosis; Object *a*; Perversion; Phobic neurosis; *Phylogenetic Fantasy, A: Overview of the Transference Neuroses*; Primal scene; Psychoanalytic nosography; Psychosexual development; Psychotic/neurotic; "Repression"; Self psychology; "Seventeenth-Century Demonological Neurosis, A"; Subject of the unconscious; Symptom-formation; Topography; Transference neurosis; Traumatic neurosis; War neurosis.

### Bibliography

- Freud, Sigmund. (1894a). The neuro-psychoses of defence. *SE*, 3: 41–61.
- . (1909b). Analysis of a phobia in a five-year-old boy. *SE*, 10: 1–149.
- . (1918b [1914]). From the history of an infantile neurosis. *SE*, 17: 1–122.

———. (1920g). Beyond the pleasure principle. *SE*, 18: 1–64.

———. (1924b [1923]). Neurosis and psychosis. *SE*, 19: 147–153.

Klein, Melanie. (1946). Notes on some schizoid mechanisms. *International Journal of Psycho-Analysis*, 27, 99–110.

———. (1975). On the sense of loneliness. In *The writings of Melanie Klein*, Vol. 4: *Envy and gratitude and other works, 1946–1963*. London: Hogarth. (Originally published 1963)

Lacan, Jacques. (1988). Introduction and reply to Jean Hypolite's presentation of Freud's *Verneinung*. In *The seminar of Jacques Lacan*. Book 1: *Freud's papers on technique, 1953–1954* (John Forrester, Trans.). New York: W. W. Norton. (Original work published 1954)

Segal, Hanna. (1957). Notes on symbol formation. *International Journal of Psycho-Analysis*, 38, 391–397.

———. (1988). *Introduction to the work of Melanie Klein*. London: Karnac Books.

———. (1991). *Dreams, phantasy, and art*. London: Routledge and the Institute of Psycho-Analysis.

### Further Reading

- Shapiro, David. (1999). *Neurotic styles*. New York: Basic.

---

## NEUROSIS AND HUMAN GROWTH

According to Karen Horney in *Neurosis and Human Growth*, people defend themselves against feeling unsafe, unloved, and unvalued by developing interpersonal and intrapsychic strategies of defense. The interpersonal strategies involve adopting a self-effacing, expansive, or resigned solution. Each of these solutions entails a constellation of personality traits, behaviors, and beliefs, and a bargain with fate in which obedience to the dictates of that solution is supposed to be rewarded. Because people tend to employ more than one solution, they are beset by inner conflicts.

In the self-effacing solution, people try to gain safety, love, and esteem through dependency, humility, and self-sacrificing "goodness." Their bargain is that if they are helpful, submissive people who do not seek their own gain or glory, they will be treated well by fate and by other people.

There are three expansive solutions: the narcissistic, the perfectionistic, and the arrogant-vindictive. Narcissists are full of self-admiration, have an unquestioned belief in their own greatness, and often display unusual charm and buoyancy. Their bargain is that if they can hold onto their exaggerated claims for themselves, life is required to give them what they want. Perfectionists take great pride in their rectitude. They have a legalistic bargain in which correctness of conduct ensures fair treatment by fate and fellow humans. Arrogant-vindictive people have a need to retaliate for childhood injuries and to achieve mastery by manipulating others. They do not count on life to give them anything but are convinced that they can reach their ambitious goals if they remain true to their vision of the world as a jungle and do not allow themselves to be influenced by their softer feelings or the traditional morality.

Resigned people worship freedom, peace, and self-sufficiency. Their bargain is that if they ask nothing of others, they will not be bothered; that if they try for nothing, they will not fail; and that if they expect little of life, they will not be disappointed.

The intrapsychic strategies are linked to the interpersonal. To compensate for feelings of weakness, inadequacy, and low self-esteem, people develop an idealized image of themselves that they seek to actualize by embarking on a search for glory. The idealized image generates neurotic pride, neurotic claims, and tyrannical shoulds. People take pride in the imaginary attributes of their idealized selves, demand that the world treat them in accordance with their grandiose conception of themselves, and drive themselves to live up to the dictates of their solution. This tends to intensify self-hate, since any failure to live up to one's shoulds or of the world to honor one's claims leads to feelings of worthlessness. The content of the idealized image is most strongly determined by the predominant interpersonal strategy, but because the subordinate strategies are also at work, the idealized image is full of inner divisions. As a result, people are often caught in a crossfire of conflicting shoulds.

The object of therapy for Horney is to help people relinquish these self-defeating defenses and actualize their real selves. This book is a major contribution to psychoanalytic theory and has influenced the study of literature, biography, gender, and culture.

BERNARD PARIS

See also: Horney-Danielson, Karen.

### Source Citation

Horney, Karen. (1950). *Neurosis and human growth: The struggle toward self-realization*. New York: W. W. Norton.

### Bibliography

Horney, Karen. (1937). *The neurotic personality of our time*. New York: W. W. Norton.

———. (1939). *New ways of psychoanalysis*. London: Kegan Paul, Trench, Trubner and Co.

———. (1942). *Self-analysis*. New York: W. W. Norton.

———. (Ed.). (1946). *Are you considering psychoanalysis?* New York: W. W. Norton.

Paris, Bernard. (1994). *Karen Horney: A psychoanalyst's search for self-understanding*. New Haven, CT: Yale University Press.

---

## NEUROTIC DEFENSES

Neurotic defenses are procedures developed by the ego which can be considered damaging to mental life. Their function is avoiding the anxiety and guilt caused by inhibitions connected with sexual desires and aggressive tendencies. They reveal the complexity and vicissitudes of the links between affect and representation.

In 1896, Freud demonstrated that defense is the “core” of the neurotic psychic mechanism. This conclusion followed his analysis of the neuro-psychoses of defense (1894a). In this text he linked repression to hysteria, and designated conversion as a defense. Conversion was later placed in the category of symptoms. In his early writings on hysteria, Freud spoke of “abreaction,” a kind of hallucinatory reproduction of memories or of emotional release as a means for dissolving conversion symptoms. Later, repression (the “model” of the defenses) came to be considered the essential first line of defense of the obsessive (or phobic) subject.

It was not until 1926 that “isolation” replaced repression as the major mechanism of obsessional neurosis. Freud saw in the obsessional neurosis a separation of representation (image, thought, memory) from the drive and its affect, while this affect, through “displacement” or “transposition,” established a link with another representation that pushes



the earlier representation, with which it is irreconcilable, into the unconscious, making it inaccessible to memory.

In *The Interpretation of Dreams* (1900a), Freud presented regression as a type of defense, to the extent that he considered it as “an effect of a resistance opposing the progress of a thought into consciousness along the normal path” (p. 546), adding that “regression plays a no less important part in the theory of the formation of neurotic symptoms than it does in that of dreams” (p. 548).

In “Repression” (1915d), he resumed his minute analyses of neurotic defenses in connection with the “return of the repressed,” whose similarity with the mechanisms of dream work was evident. He focused on the linking of affect and representation through the processes at work in anxiety or (phobic) hysteria, whose proximity with conversion hysteria and obsessional neurosis he emphasized. “Displacement” is the major defense of the phobic neurotic, while for the obsessional neurotic there is “a substitute by displacement, often a displacement on to something small or insignificant” (p. 157). Finally, with conversion hysteria, there is the “*belle indifférence*” (p. 156, [sic]): at the same time as a factor of regression, one also of “condensation.” This is because a portion of the repressed representation of the drive has attracted to itself, by condensation, the totality of the cathexis, as well as a tendency for identification.

Other defenses were considered by Freud: projection, a very basic type of defense Freud alluded to throughout his work; delusional jealousy (1922b), which is a defense against homosexuality; the distinction between internal and external, which is a means for the ego to defend itself against that which is experienced as disagreeable (*Civilization and Its Discontents*, 1930a).

The analysis of defenses has been refined and extended in the work of Helene Deutsch (1926), Otto Fenichel (1932), and Maurice Bouvet (1967–68), among others. For the phobic neurotic, “avoidance” of anxiety, “canceling” and “reaction formation” were added. Sublimation (Freud, 1905, 1910) was finally considered as a separate kind of defense (Hartmann, 1955), since it is the only one that implies a change of the kind of energy.

This refinement of the analysis of defenses has allowed the consideration of neurosis as other than an

essentially pathological system. Currently, these defenses are also described in the context of what is called normal-neurotic psychic activity. On the other hand, the study of traumatic neuroses since Freud, including mechanisms of repetition, splitting, and denial, as well as the study of psychic functioning in what have been called borderline processes, have probably contributed to a certain vulgarization of these defensive manifestations, which, nevertheless, remain essential for an understanding of Freudian metapsychology.

ELSA SCHMID-KITSIKIS

*See also:* Defense.

### **Bibliography**

- Bouvet, Maurice. (1967). *Oeuvres psychanalytiques. I, La Relation d'objet: Névrose obsessionnelle, dépersonnalisation*. Paris: Payot.
- . (1968). *Oeuvres psychanalytiques. II, Résistance, transfert*. Paris: Payot.
- Fenichel, Otto. (1953). *The Collected Papers of Otto Fenichel*. (First and Second Series; H. Fenichel and D. Rapaport, Eds.). New York: Norton.
- Freud, Sigmund. (1894a). The neuro-psychoses of defence. *SE*, 3: 41–61.
- . (1915d). Repression. *SE*, 14: 141–158.

---

## **NEUROTICA**

Freud created the neologism *neurotica* to refer to his first approach to the etiology of the neuroses. The word appears only once in Freud's writing, in a letter to Fliess dated September 21, 1897. In an earlier letter, dated January 24, 1897, Freud had introduced a similar neologism: “The majority of my assumptions on the *neuroticis* were subsequently confirmed.” The September 21 letter, however, is more pessimistic: “And now I must immediately reveal to you the great secret that, during these past months, has slowly begun to become clear. I no longer believe in my *neurotica*.”

According to Freud's *neurotica*, the etiology of the neuroses unfolds in three stages:

1. Some form of sexual abuse was committed by someone close to the person, possibly a parent.

Freud placed the abuse in adolescence and then traced backward in time to place it in childhood and even early infancy.

2. The scene involving the abuse is repressed.
3. The repressed traumatic scene has a tendency to reappear in the form of anxiety or symbolic acts. This leads to the well-known formulation that “hysterics suffer from reminiscences.” It is the father’s perversion that is responsible for the neurosis of the child: “Hysteria is the negative of perversion.”

It is this conception of the traumatic etiology of the neurotica that Freud questioned in his September 21 letter to Fliess. The generalization about the perversion of fathers now seemed unlikely to Freud, who claimed, “There are no indications of reality in the unconscious, so that one cannot distinguish between truth and fiction that has been cathected with affect. (Accordingly, there would remain the solution that the sexual fantasy invariably seizes upon the theme of the parents.)” This led Freud to a new conception of the etiology of neurosis, a conception based on fantasy rather than trauma.

No sooner had Freud finished his letter to Fliess questioning his neurotica theory than he hastened to Berlin to meet Fliess and clarify his position. Freud returned to Vienna in a state of great intellectual agitation, filled with dreams, reminiscences, and parapraxes associated with conversations between himself and his mother about his childhood. An intense two-week period of mental scrutiny resulted in Freud’s discovery of the Oedipus complex. The question of what is prominent is the origin of the neurosis, actual real events or psychic reality, combined to preoccupy Freud throughout his scientific life (see the “Wolf Man” case, 1918b [1914]).

Freud’s abandoning his neurotica later gave rise to a number of comments, critiques, and developments. Marie Balmory and Marianne Krüll have investigated, from a psychoanalytic point of view, what drove Freud to abandon the seduction theory. They explained his abandonment not in terms of scientific motives but rather in terms of Freud’s relationship with his father, and they saw his abandoning the theory as an attempt to protect his father. In a more polemical vein, Jeffrey M. Masson has reproached Freud for abandoning this theory out of cowardice before his Viennese colleagues and denying the reality of the sexual abuse whose victims were girls and women. Jean Laplanche addressed

the problem from the opposite point of view and provided an original interpretation that ranges from limited to generalized seduction. He saw the seduction as coming not from the father but from the mother and considers the seduction to be “a fundamental situation, where the adult proposes to the child non-verbal and verbal, even behavioral, signifiers impregnated with unconscious sexual meanings.”

DIDIER ANZIEU

*See also:* *Construction de l’espace analytique (La-)* (Constructing the analytical space); Family; Fantasy; “Heredité and the Aetiology of the Neuroses”; Mythology and psychoanalysis; Psychic causality; Psychic reality; Seduction; Sexual trauma.

### **Bibliography**

- Balmory, Marie. (1982). *Psychoanalyzing psychoanalysis: Freud and the hidden fault of the father* (Ned Lukacher, Trans.). Baltimore: Johns Hopkins University Press. (Original work published 1979)
- Freud, Sigmund. (1918b [1914]). From the history of an infantile neurosis. *SE*, 17: 1–122.
- . (1950a [1887–1902]). Extracts from the Fliess papers. *SE*, 1: 173–280.
- Krüll, Marianne. (1986). *Freud and his father* (Arnold J. Pomerans, Trans.). New York: W. W. Norton. (Original work published 1979)
- Laplanche, Jean. (1989). *New foundations for psychoanalysis*. Cambridge, MA: Basil Blackwell. (Original work published 1987)
- Masson, Jeffrey M. (1984). *The assault on truth*. New York: Farrar, Straus and Giroux.
- Robinson, Paul A. (1993). *Freud and his critics*. Berkeley: University of California Press.

---

## **NEUTRALITY/BENEVOLENT NEUTRALITY**

The terms *neutrality* and *benevolent neutrality* characterize the counter-transference attitude that the psychoanalyst is supposed to adopt throughout the psychoanalytic treatment. Though Freud did not use these particular terms, he did, however, stress the climate of “abstinence” in which the treatment should take place. The introduction of the word neutrality is attributed to James Strachey, who used it in 1924 to

translate the word *Indifferenz* in Freud's "Observations on Transference Love."

We know from the testimonies of patients like Smiley Blanton and Joseph Wortis how far Freud himself was from remaining "neutral" in the way he conducted his sessions. On October 26, 1934, he even announced to Wortis that "The psychoanalytic relation is not a chivalrous relation between two equals" (Wortis, 1954). However, though Anna Freud did not use the term either, she nevertheless lent substance to the notion of neutrality: When summarizing Freud's description of the analyst as "opaque like a mirror," she defined the analyst's position as "at a point that is equidistant from the id, the ego and the superego" (Freud, 1936/1937). Alex Hoffer later suggested adding "external reality" to that list (Hoffer, 1985).

Edmund Bergler coined the expression *benevolent neutrality* at the Symposium on the Theory of the Therapeutic Results of Psycho-Analysis in 1937, and the term met with much success after World War II. Most American psychoanalysts naturally followed his example, but some French analysts, like Daniel Lagache (1950) and Sacha Nacht (1954), did as well. Nacht stressed that the analyst must not abandon "benevolence" all through the treatment and even introduced the notion of "goodness."

Over time, "neutrality" was interpreted in two very divergent ways. Some analysts adopted an excessively cold and indifferent, even amoral, attitude to the things that are said in the course of a session. This spurred Otto Kernberg to suggest the term "technical neutrality" in order to distinguish between a "lack of spontaneity and natural warmth" and an "authentic concern for the patients [...] that protects their autonomy, independence and capacity to accomplish their work on their own" (Kernberg, 1976).

In opposition to that, particularly after Otto Rank and Sándor Ferenczi stressed the importance of the primary relation with the mother and its repetition in the transference, as well as the idea of comprehensive receptivity that can rightly or wrongly be associated with notions of repairing, of *holding* and *handling*, other analysts stressed benevolence and adopted increasingly maternal and gratifying attitudes in treating difficult patients.

Moreover, the ideas of authors like Heinz Hartmann, Ernst Kris, and Rudolph Loewenstein with regard to the latest theory of instincts have brought the

concept of an "aconflictual sector" to the fore, which may account for the special success of the notion of neutrality in Anglo-Saxon literature.

ALAIN DE MIJOLLA

*See also:* Abstinence/rule of abstinence; Contact and psychoanalysis; Evenly-suspended attention; Psychoanalyst; Therapeutic alliance; Training of the psychoanalyst.

### **Bibliography**

- Franklin, Girard. (1990). The multiple meanings of neutrality. *Journal of the American Psychoanalytic Association*, 38, 195–220.
- Freud, Anna. (1937). *The ego and the mechanisms of defence*. London: Hogarth. (Original work published 1936)
- Hoffer, Axel. (1985). Toward a definition of psychoanalytic neutrality. *Journal of the American Psychoanalytic Association*, 33, 771–795.
- Innes, Smith J. (1990). La neutralité de l'analyste. *Revue belge de psychanalyse*, 17, 43–58.
- Kernberg, Otto F. (1976). Technical considerations in the treatment of borderline personality organization. *Journal of the American Psychoanalytic Association*, 30, 795–829.
- Lagache, Daniel. (1950). Homosexuality and jealousy. *International Journal of Psycho-Analysis*, 31 (1–2), 24–31.
- Nacht, Sacha. (1954). The difficulties of didactic psychoanalysis in relation to therapeutic psycho-analysis. *International Journal of Psycho-Analysis*, 35 (2), 250–253.
- Wortis, Joseph. (1954). *Fragments of an analysis with Freud*. New York: Simon and Schuster.

### **Further Reading**

- Makari, George. (1997). Current conceptions of neutrality and abstinence. *Journal of the American Psychoanalytic Association*, 45, 1231–1240.
- Poland, Warren S. (1984). On the analyst's neutrality. *Journal of the American Psychoanalytic Association*, 32, 283–300.
- Renik, Owen. (1996). The perils of neutrality. *Psychoanalytic Quarterly*, 65, 495–517.

---

## **NEW INTRODUCTORY LECTURES ON PSYCHO-ANALYSIS**

In 1932 the financial situation of the world, shaken by the aftermath of World War I and the economic crisis

that had struck the United States, threatened the existence of the Internationaler Psychoanalytischer Verlag (International Psychoanalytical Publishers). Measures were taken, including an appeal to psychoanalytic societies and the creation of an international management committee, at the Twelfth International Psychoanalytic Congress held in Wiesbaden in September 1932.

Beginning in the spring of that year, however, Freud was occupied with writing a follow-up to the volume that, of all his works, remains the most popular worldwide: his *Introductory Lectures on Psycho-Analysis* (1916–17 [1915–17]). This follow-up was the *New Introductory Lectures on Psychoanalysis*, completed at the end of August and released on December 6, 1932, despite the 1933 copyright date.

In his preface, Freud explained that illness prevented him from teaching courses as he had done in 1915, but that he had used “an artifice of the imagination” (p. 5) to write these lectures, which, he said, were only “continuations and supplements” (p. 5) of the earlier lectures—hence their numbering. In reality, these texts represented a major synthesis and updating of theories that had been considerably modified since 1923. They were no longer intended for a neophyte public, but for informed readers who were to find in them theoretical and practical advice and refinements.

The twenty-ninth lecture is titled “Revision of the Theory of Dreams.” It contains few new elements, except for the assertion that not all dreams can be interpreted, and the attenuation of the former understanding of dreams as “wish-fulfillment” by taking into account repetition in traumatic neuroses or the reproduction of painful childhood events.

The thirtieth lecture, “Dreams and Occultism,” takes on a universally contested subject. Although Freud set forth all the arguments that cause the scientific mind to doubt the existence of telepathic transmission, he also gave some examples of observations that had perplexed him, including that of Vorsicht/Forsyth, and he wrote, “I must encourage you to have kindlier thoughts on the objective possibility of thought-transference and at the same time of telepathy as well” (p. 54).

The thirty-first lecture, “Dissection of the Psychical Personality,” emphasizes subjects that had characterized theoretical research in psychoanalysis since the establishing of the second topography (structural

theory): stress upon the ego, the importance of the superego, the abandonment of the agency of the unconscious in favor of recognizing an “unconscious” character in other sectors of the personality, and its replacement by the agency of the id. The lecture concludes with the well-known propositions concerning “the therapeutic efforts of psychoanalysis. . . . Its intention is, indeed, to strengthen the ego, to make it more independent of the super-ego, to widen its field of perception and enlarge its organization, so that it can appropriate fresh portions of the id. Where id was, there ego shall be [*Wo Es war, soll Ich Werden*]. It is a work of culture, not unlike the draining of the Zuider Zee” (p. 80).

The thirty-second lecture, “Anxiety and Instinctual Life,” describes the new theory already put forth in “Inhibitions, Symptoms and Anxiety” (1926), which holds that repression is not what creates anxiety; rather, anxiety, residing in the ego alone, is what creates repression. Moreover, “the instinctual situation which is feared goes back ultimately to an external situation of danger” (p. 89): the danger of the state of powerless to help oneself (*Hilflosigkeit*) in the earliest period of life, the danger of castration in the phallic stage, anxiety in the face of the superego during the latency period. The lecture ends with a presentation of the “theory of the instincts” which “is so to say our mythology” (p. 95). The return to a description of the instincts and their vicissitudes leads, above all, to a new picture of the opposition and blending of the sexual instincts, Eros, and the aggressive instincts, “the expression of a ‘death instinct’ which cannot fail to be present in every vital process” (p. 107).

The thirty-third lecture, “Femininity,” has caused a good deal of controversy. The “riddle of femininity” (p. 116) is not explained, and rather than trying to describe “what a woman is” (p. 116) Freud tried to understand “how she comes into being” (p. 116). He emphasized the girl’s preoedipal attachment to her mother and the frequency of its transformation into hate at the time of the organization of “penis envy.” Henceforth, he would view this early bond of love and the needs that accompany it as the source of fantasies of seduction. However, faced with “the riddle of femininity,” he concluded: “If you want to know more about femininity, enquire from your own experiences of life, or turn to the poets, or wait until science can give you deeper and more coherent information” (p. 135).

The thirty-fourth lecture, titled “Explanations, Applications and Orientations,” returns to the points of dissent that had marked the history of psychoanalysis and comments on them. In the section on applications there is a plea in favor of teaching—with Freud commenting, “I am glad that I am at least able to say that my daughter, Anna Freud, has made this study her life-work” (p. 147)—and thus in favor of the use of analytic therapy for children. “[E]ducation must find its way between the Scylla of non-interference and the Charybdis of frustration” (p. 149), Freud reminded readers, before giving his concluding considerations on psychoanalysis as therapy: “You are perhaps aware that I have never been a therapeutic enthusiast” (p. 151), but nevertheless, “[c]ompared with the other psychotherapeutic procedures psycho-analysis is beyond any doubt the most powerful” (p. 153). However, in cases such as psychoses where a constitutional factor comes into play, the weight of the family environment for children, and the rigidity of some adults shows the limits of possible action. Further, the analytic work requires a long period of treatment, despite attempts that had been made (Otto Rank) to shorten cures.

The final lecture, “On a Weltanschauung,” was actually written first, and it refuses psychoanalysis the pretension of offering a new world view. Its scope is limited to the scientific, and in this it differs from religion and philosophy, as well as from political ideologies such as bolshevism.

Freud concluded with a paean to science, to which psychoanalysis must link itself. “A Weltanschauung erected upon science has, apart from its emphasis on the real external world, mainly negative traits, such as submission to the truth and rejection of illusions. Any of our fellow-men who is dissatisfied with this state of things, who calls for more than this for his momentary consolation, may look for it where he can find it” (p. 182).

ALAIN DE MIJOLLA

*See also:* Anxiety; Castration complex; Change; Dream; Femininity; Identification; Occultism; Phallic woman; Politics and psychoanalysis; Psychic apparatus; Psychic causality; Science and psychoanalysis; Superego.

### Source Citation

Freud, Sigmund. (1933a [1932]). *Neue folge der vorlesungen sur einfuhrung in die psychoanalyse*. Leipzig, Vienna, and

Zurich: Internationaler Psychoanalytischer Verlag; New introductory lectures on psycho-analysis. *SE*, 22: 1–182.

---

## NEW YORK FREUDIAN SOCIETY

The New York Freudian Society was founded in 1959 as the New York Society of Freudian Psychologists. (Its name was changed to comply with the New York State Psychology Certification Law.) As of 2004, with more than 200 members, it is the largest independent society within the International Psychoanalytical Association (IPA). Gisela S. Barinbaum, born in Vienna, founded the Freudian Society with a small group of analysts, many of whom were her patients or supervisees. Like the Institute for Psychoanalytic Training and Research (founded in 1958), also an IPA society, and several other New York training institutes, the society was formed by members who split from the National Psychological Association for Psychoanalysis (NPAP), founded by Theodor Reik in 1948. The apparent reasons for the split were theoretical differences, but the underlying reasons were probably personal. The national association was considered not sufficiently Freudian in spite of Reik’s connection to Freud, and Reik, uninterested in psychoanalytic politics, made no effort to keep members from leaving.

The society grew slowly, having only a small number of members until the mid-1960s, when another younger group of disaffected NPAP members joined the organization and supplanted the original group that had coalesced around Barinbaum. Membership and the body of candidates grew steadily with the addition of analysts from the National Psychological Association for Psychoanalysis, the New York University Postdoctoral Program in Psychoanalysis and Psychotherapy, and analysts who had “bootleg” training, often by members of the New York Psychoanalytic Society. Barinbaum died in 1981, but her influence by that time had become insignificant.

A lawsuit seeking to restrict the mental-therapy trade, brought by members of the American Psychological Association against the American Psychoanalytic Association and the International Psychoanalytical Association, proved beneficial to the New York Freudian Society. The settlement of the lawsuit permitted societies to apply to the International Psychoanalytical Association. Site visits by the association followed

from 1987 to 1989, and the New York Freudian Society became a provisional member of the association in Rome in 1989 and a component society of the association in Amsterdam in 1993. The Confederation of Independent Psychoanalytic Societies, as of 2004, includes four independent American IPA societies.

The society's program of instruction and requirements for graduation follow a model used by the National Psychological Association for Psychoanalysis (which in turn is based on a model of the Berlin Institute for Psychoanalysis, probably originated by Reik, who taught there). Its four years of course work are best characterized as contemporary Freudian in content. It has a program of instruction in Washington, D.C., and a program in child and adolescent analysis in New York and Washington. Its programs have 100 analysts in training as a result of a less formerly restrictive approach toward who is eligible to become a training analyst—a carryover from the National Psychological Association for Psychoanalysis. A board of directors governs the society and its attached Psychoanalytic Training Institute. About half its members are psychologists, 40 percent social workers, and 10 percent physicians. The training institute has 100 candidates in various stages of training.

The society sponsors numerous scientific programs, an annual conference, and many study groups and presentations. Its members publish widely and make important contributions to the broader psychoanalytic community. In 2004 almost half of the members of the Freudian Society were graduates of the Psychoanalytic Training Institute.

JOSEPH REPPEN

*See also:* International Psychoanalytical Association; United States.

## NEW YORK PSYCHOANALYTIC INSTITUTE

The New York Psychoanalytic Institute is an educational institution whose purpose is the training of psychoanalysts in the Freudian tradition.

Its origins derive from an organization, the New York Psychoanalytic Society, founded by Abraham Arden Brill and others in 1911 for the study of psychoanalysis, the first such organization in the United

States. Brill had previously translated Freud into English, published in a widely-distributed Modern Library edition.

After World War I a small group of psychiatrists from New York went to Vienna for personal analysis with Freud with a view to obtaining a psychoanalytic education. Their number increased in the 1920s with the addition of Americans who had been formally trained in the institutes of Berlin, Budapest, and Vienna. In response to a growing demand for formal instruction the New York Psychoanalytic Society organized its first series of lecture courses in the fall of 1922, and in 1923 appointed its first educational committee to organize and improve the teaching functions of the society. Enrollment was limited to physicians with an MD degree to conform to the recent standardization of medical education in the United States. The basic structural elements of the tripartite model was already in place: personal analysis, seminars, and the supervision of cases in analysis.

On September 24, 1931, the New York Psychoanalytic Society established the New York Psychoanalytic Institute, patterned after the Berlin Psychoanalytic Institute from which Sandor Rado was recruited to become the first educational director. The institute has been educationally autonomous and financially self-supporting from its inception. The graduates of the New York Psychoanalytic Institute become members of the New York Psychoanalytic Society. Dues, tuition, and income from an endowment created by the members provide the funds. Then as now, the society sponsors the presentation and discussion of scientific papers and interdisciplinary seminars. The institute, responsible for the training of candidates, selects teachers and training analysts, at first by the Educational Committee itself, later by the faculty electing an ad hoc committee which has come to include the intensive evaluation of current psychoanalytic work.

In the 1930s, psychoanalysis was an important part of the intellectual ferment of the times so that prominent intellectuals as well as many others sought personal analysis. Eminent psychoanalytic writers who contributed to the expansion of psychoanalytic knowledge at that time included Bertram Lewin, Paul Schilder, Sandor Rado, and Sandor Lorand.

During World War II, the successful application of psychoanalytic principles to the treatment of war neuroses, the only set of ideas that explained these condi-

tions, influenced many American doctors to seek psychiatric training so that they could qualify for psychoanalytic training. Applications to the institute exceeded 60 in those years, and classes of 30 were not unusual, compared to the early twenty-first century's average number of applications of six to eight and classes of four or five.

Hitler's persecution resulted in the immigration of large numbers of eminent European psychoanalysts who became intellectual leaders and senior teachers. In New York these included Heinz Hartmann, Ernst Kris, Rudolph Loewenstein, Edith Jacobson, Robert Bak, Kurt Eissler, and many others. In cooperation with Anna Freud, they established contemporary ego psychology. In the area of child analysis leadership was supplied by Berta Bornstein, Marianne Kris, and Margaret Mahler.

Hartmann introduced the adaptational point of view as part of his effort to make psychoanalysis a general psychology. These ideas as well as the earlier contributions by psychoanalytic thinkers in the 1940s, 1950s, and 1960s greatly influenced the fields of social science, mental hygiene and child care. The New York Institute in that period served as a model for institutes throughout the United States.

With the passing of the European psychoanalysts in the 1970s and 1980s, the mantle of leadership fell chiefly to Jacob Arlow and Charles Brenner, who also clarified and codified Freud's contributions in 1923 and 1926, and outlined a modern, contemporary psychoanalysis based on human psychology viewed as the outcome of intrapsychic conflict.

There have been many profound teachers who published very little, but influenced large numbers of candidates at the institute. One such individual was Otto Isakower, who revised the curriculum in the late 1950s from a chronological reading of Freud's works to a topic-dominated collection of courses covering the literature from Freud's earliest works to contemporary contributors and critics within the Freudian tradition. In recent years many of the proliferation of divergent ideas in psychoanalysis have been added to the curriculum.

The administrative structure of the New York Institute and Society is a representative democracy. Every graduate of the Institute becomes a member of the Society and automatically a member of the Institute, with the right to vote and hold office in both. The Society is concerned with the scientific program and

the relationship to other societies of the American Psychoanalytic Association; the Institute with psychoanalytic training. The governing body of the Institute is the Educational Committee. The training analyst members of the faculty select a committee that nominates training analysts who are eligible for membership on the Educational Committee. The electorate consists of the entire membership of the Institute/Society.

In recent years there has been a vast expansion of the Institute's and Society's activities beyond the training of candidates. There is a large Extension School for psychiatric residents, psychology interns, and social work doctoral candidates which teaches psychoanalytic principles, psychotherapy, child development, and various special subjects such as dreams, and the treatment of severe character disorders. The Institute also provides an externship for graduate students in psychology which includes supervision of psychotherapy, and a fellowship program for selected potential candidates which has come to include psychiatric residents and PhD students in psychology and social work. This program offers seminars in theory and case supervision. A psychotherapy training program is in the planning stage. With the decline of psychoanalysis as a profession in the United States, and its fragmentation as a discipline, the New York Institute is attempting to teach what is considered fundamental to the Freudian tradition, but does not neglect the multiplicity of ideas and technical innovations that have emerged and have contributed to enlarging our psychoanalytic understanding. The Institute has also expanded its interaction with training programs of potential candidates, and with the community at large, to attempt to educate larger numbers about psychoanalysis and its value.

MANUEL FURER

*See also:* American Academy of Psychoanalysis; American Psychoanalytic Association; Splits in psychoanalysis; Training analysis; United States.

### **Bibliography**

- Hartmann, Heinz, Kris, Ernst, and Loewenstein, Rudolph. (1964). *Papers on psychoanalytic psychology*. New York: International Universities Press.
- Wangh, Martin (Ed.). (1962). *Fruition of an idea*. New York: International Universities Press.

## NIGHT TERRORS

Night terrors are pathological phenomena that begin around three or four years of age. The child suddenly wakes up at the beginning of the night; he or she is terrified, screams in bed, and seems to be in the grip of hallucinations. When the worried parents arrive, the child does not recognize them and they are unable to calm the child. This state persists for a few minutes, at most, and brings with it neurovegetative manifestations (sweating, tachycardia, and polypnea). Once he or she has calmed down, the child goes back to sleep. The next day the child has no memory of the episode. Night terrors can be recurrent, but in general they disappear around the age of five or six.

There is no reference to night terrors in the works of Sigmund Freud. The phenomenon is difficult to apprehend from a psychoanalytic point of view; because of the amnesia that follows them, night terrors are not accessible, as dreams are, to any secondary revision. This sleep disorder probably reflects a failure in the dreaming function—a weakness in figuration and the binding of affects with mental representations.

We can refer to the work of Didier Houzel, who used electrophysiological observations as the starting point for a physiological explanation for night terrors. They occur during the phases of slow wave sleep (phase IV), outside of the phases of paradoxical sleep in which dreams occur. Phase IV sleep includes physiological aspects that herald the paradoxical sleep phase. Slow wave sleep is a reparatory phase of dream activity; night terrors suggest a blocking of the dream, which cannot begin during this slow sleep phase and, therefore, cannot proceed with the work of psychically binding instinctual energy.

As for the etiology of night terrors, which coincide with the arrival of oedipal conflict, different factors have been identified: libidinal conflicts proper to this period of emotional life, traumatic events, and, finally, disturbances in the child's affective relationships with people close to him or her. The persistence of night terrors beyond the oedipal period is a sign that the child is incapable of elaborating better psychic defenses. They can mark a return to preoedipal positions.

PHILIPPE METELLO

*See also:* Combined parent figure; Paranoid position; Phobias in children; Somnambulism.

## Bibliography

- Houzel, Didier. (1980). Rêve et psychopathologie de l'enfant. *Neuropsychiatrie de l'Enfance et de l'Adolescence*, 28, 155–164.
- Sperling, Melitta. (1958). Pavor nocturnus. *Journal of the American Psychoanalytic Association*, 1, 79–94.

## NIGHTMARE

Nightmares are dreams whose contents are unpleasant or anxiety provoking and which, depending on their intensity, can awaken the sleeper. Also known as anxiety dreams, nightmares attracted the interest of Sigmund Freud, who refers to them for the first time in *The Interpretation of Dreams*. There, he shows how nightmares are not an exception to dream theory and, more specifically, that they are consistent with the theory that dreams are the fulfillment of a wish. The anxiety experienced during the nightmare can only be apparently explained by its content. Although intrinsically linked to its accompanying representations, the anxiety arises from a different source. In this sense the anxiety of the dream is identical to the anxiety experienced during neurosis.

Based on this analogy, Freud claims that nightmares are dreams with a sexual content whose libido is transformed into anxiety. The content is generally exempt from any form of distortion and represents the unveiled realization of a repressed desire that has shown itself to be stronger than censorship. The anxiety that accompanies the dream then takes the place of the censorship.

Nightmares can awaken the dreamer, and sleep can be interrupted before the dream's repressed desire has, faced with the censorship, reached its complete realization. In this case there is a failure to form the compromise that constitutes the dream, which then fails to fulfill its function as the guardian of sleep.

Although Freud did not change his dream theory, he updated it in *Beyond the Pleasure Principle* (1920). The repetitive anxiety dreams observed in people suffering from traumatic neuroses cannot be explained by the fulfillment of a repressed desire. In these nightmares a profoundly unpleasant and anxiety provoking event is repeated. To explain this, Freud introduces the hypothesis that the dream serves to bind the instinc-



tual excitation to avoid overwhelming the psychic apparatus with traumatic material. In traumatic neurosis this binding function is disturbed.

Ernest Jones, in his book *On the Nightmare*, interpreted anxiety dreams as the fulfillment of a repressed wish associated with infantile sexuality. More recently, French authors, relying on experimental findings that reveal that through the different paradoxical sleep cycles the same dream matter becomes increasingly less comfortable as dreaming progresses, have hypothesized that this phenomenon may be the reflection of the dream's work of organization, integration, or binding. This would result in the gradual development of the most archaic signifiers, increasing their complexity, combining them, and dramatizing them in primary fantasies that have been relegated to secondary importance. According to this assumption, nightmares are the reflection of the failure of these binding processes, whereby anxiety occurs through the inability to repress archaic signifiers.

PHILIPPE METELLO

*See also:* Annihilation anxiety; Anxiety dream; Cinema and psychoanalysis; "From the History of an Infantile Neurosis" (Wolf Man); Garma, Angel; Pasche, Francis Léopold Philippe; Phobias in children; *Secrets of a Soul*; Traumatic neurosis; War neurosis.

### **Bibliography**

- Freud, Sigmund (1900a). The interpretation of dreams. *SE*, 4–5.
- . (1920g). Beyond the pleasure principle. *SE*, 15: 273–338.
- Golse, Bernard. (1992). Cauchemars, rêves et processus de pensée. *Psychiatrie de l'Enfant*, 37, 2, 395–413.
- Houzel, Didier. (1980). Rêve et psychopathologie de l'enfant. *Neuropsychiatrie de l'Enfance et de l'Adolescence*, 28, 155–164.
- Jones, Ernest. (1949). *On the nightmare*. London: Hogarth Press and the Institute of Psycho-Analysis.

---

## **NIN, ANAÏS (1903–1977)**

Anaïs Nin, a diarist, writer, and lay analyst, was born on February 21, 1903, in Neuilly, near Paris. She died on January 16, 1977 in Los Angeles.

She was the daughter of Joaquin J. Nin y Castellanos (1879–1949), Cuban-born Spanish pianist and composer, and Rosa Culmell (1871–1954), Danish-French soprano. Nin lived in France, Belgium, Germany, and Spain until 1914, when her mother took her and two younger brothers to America. Her father, a compulsive Don Juan, had deserted his family for a young student. In New York Nin soon quit school, educated herself, and worked as a model for artists and clothing manufacturers.

In 1923 she married Boston-born Hugh Parker Guiler (1898–1985), a Columbia University graduate. From 1924 until 1939 the Guilers lived in Paris, where "Hugo" became an officer of an America bank, and Nin pursued her writing. They returned to New York in 1940, due to the war, and Nin, in 1948, began a "trapeze" life between her husband in New York and a lover in California, which she secretly pursued for almost thirty years. She died of cancer in Los Angeles in January 1977.

Lastingly traumatized by the enforced separation from her beloved father, on her journey into lifelong "exile," the eleven-year-old Catholic girl began a deeply confessional diary, from which edited selections first appeared in 1966. A record of an unending effort to realize and reconcile multiple potentials of an essentially fluid self, to find absolution in art, and to express an unrestrained female sexuality—see, for instance, the erotic stories in *Delta of Venus* (1977) and *Little Birds* (1979)—Nin's *Diary* stands as a unique, massive, psychological document of a woman's life in the 20th century.

Nin read and defended D. H. Lawrence in her first book, *An Unprofessional Study* (1932), and had an incestuous reunion with her father in 1933. Confused by her eruptive sexual awakening, and after discovering psychoanalysis, Nin initially became a patient of René Allendy, who failed to understand her creative needs. Her next treatment was with Otto Rank, who fell in love with her. In 1934 she followed Rank to New York. She briefly served as his assistant and conducted result-oriented therapy sessions with a number of patients in 1935 and 1936, but eventually returned to Paris and her writing. See, for instance, the story "The Voice" in *Winter of Artifice* (1939).

GUNTHER STUHLMANN

*See also:* Allendy, René Félix Eugène; Rank (Rosenfeld), Otto.

## Bibliography

- Nin, Anaïs. (1936). *The house of incest, a prose poem*. Paris: Siana Press.
- . (1959). *Cities of the interior*. Athens, OH: The Swallow Press.
- . (1966–80). *The diary of Anaïs Nin, 1931–1974*. (G. Stuhlman, Ed.) New York: Harcourt, Brace and World.
- . (1978–85). *The early diary of Anaïs Nin, 1914–1931*. New York: Harcourt, Brace and World.
- . (1986–96). *A journal of love: the unexpurgated diary of Anaïs Nin, 1931–1939*. New York: Harcourt, Brace and World.

---

## NIRVANA

The term “Nirvana,” first suggested by Barbara Low and acknowledged and used by Freud, is intimately connected with the development of the concepts of the pleasure/unpleasure principle. The concept has a long history, and contributed to Freud’s understanding of the infantile wish-fulfilling character of dreams.

In Chapter Seven of *The Interpretation of Dreams* (1900a), in which Freud conceptualized the mental apparatus, he suggested that, to begin with, the apparatus is directed towards keeping itself as free from stimuli as possible in accordance with the “Principle of Constancy.” This principle was already a basic assumption, and had appeared as such in many of Freud’s earlier writings—for example in a letter to Josef Breuer (June 29, [1892] 1960a) and in various sections of Part One of the *Project for a Scientific Psychology* (1950c [1895]), through in quasi-neurological terms. But as Freud indicated in a footnote added in 1914 to the dream book, the concept is explored more fully in his paper on “The Two Principles of Mental Functioning” (1911b).

The Lust/Unlust–pleasure/pain principle is described there as the governing purpose of the primary process. There is a continued striving towards gaining pleasure, and a retreat from anything that might arouse unpleasurable affect. It is precisely the latter that dreams seek to avoid: when the state of rest is disturbed by internal needs, an attempt is made to achieve satisfaction in a hallucinatory manner.

With the emergence of the secondary process, reality is at least recognized, even when disagreeable; and the individual now must seek pleasure in accordance

with what is possible in the circumstances in which they find themselves. To put the matter in energetic terms: unpleasure was associated with a rise in excitation; pleasure with its reduction and discharge, and, with the acquisition of the reality principle, this discharge of excitation, once sought as a peremptory demand under the influence of the pleasure principle, now has to wait until reality presents the necessary conditions or until those conditions can be brought about. (Pleasure can, of course, always be expressed in fantasy and day dreams, whatever the circumstances.) The search for pleasure, it will be observed, is related to, but not identical with, the “Principle of Constancy” referred to above.

Already, especially in the paper *Instincts and their Vicissitudes* (1915c), Freud had stated that the relation existing between pleasure and unpleasure on the one hand, and the rise and the “fluctuations of the amounts of stimuli affecting mental life,” on the other, was no simple matter, and that the relations were many, various, and in need of elucidation.

In *Beyond the Pleasure Principle* (1920g) Freud reformulated his two classes of instincts and opposed the one, Eros or the Life Instinct, with the destructive or Death Instinct. The aim of the Death Instinct was to get rid of life through the running down of the organism, and therefore of the tensions within it. This “dominating tendency of mental life”—“to reduce, to keep constant or to remove internal tensions due to stimuli”—was called the “Nirvana principle,” a term suggested by Barbara Low and here adopted by Freud.

The difficulties and anomalies inherent in these formulations were reconsidered by Freud in *The Economic Problem of Masochism* (1924c). Re-affirming his adoption of the Nirvana principle, he pointed out that, if the pleasure principle were identical with it, that principle would be “in the service of the death instincts” and would act as a warning against the demands of the life instincts that threatened to disturb the intended course of life. But that view, said Freud, could not be correct. Furthermore, in the series of tensions and their increase and decrease, there were pleasurable tensions (for example, sexual excitation) and unpleasurable relaxations of tensions. Pleasure and unpleasure could not depend on some quantitative factor alone, but on some qualitative characteristics. It might be “the rhythm, the temporal sequence of changes, rises and falls in the quantity of stimulus.” Freud added: “We do not know.” Whatever the truth

of the matter, the Nirvana principle had undergone a modification in living organisms through which it had become the pleasure principle. “Henceforward,” he continued, “we shall avoid regarding the two principles as one.” And he concluded by saying that the Nirvana principle expressed the trend of the death instinct; the pleasure principle represented the demands of the libido; and the modification of the latter principle, the reality principle, represented the influence of the external world.

It may be worth adding that an optimum level of tension normally gives life its sense of vividness and alertness. Reduction of tension to zero, unless transient, is often pathological, and found, for example, in states of depression, some kinds of depersonalization, and in the anergic forms of schizophrenia.

CLIFFORD YORKE

*See also:* Death instinct (Thanatos); Desexualization; Discharge; *Ego and the Id, The*; Erotogenic masochism; Excitation; Low, Barbara; Mythology and psychoanalysis; Pleasure/unpleasure principle; Principle; Principle of constancy; Principle of (neuronal) inertia; Protective shield, breaking through the; Quantitative/qualitative.

### **Bibliography**

- Freud, Sigmund. (1900a). The interpretation of dreams. Part II. *SE*, 5: 339–625.
- . (1911b). Formulations on the two principles of mental functioning. *SE*, 12: 213–226.
- . (1915c). Instincts and their vicissitudes. *SE*, 14: 109–140.
- . (1920g). Beyond the pleasure principle. *SE*, 18: 1–64.
- . (1924c). The economic problem of masochism. *SE*, 19: 155–170.
- . (1950c [1895]). Project for a scientific psychology. *SE*, 1: 281–387.
- . (1960a [1873–1939]). *Letters of Sigmund Freud, 1873–1939* (Ernst L. Freud, Ed.; Tania and James Stern, Trans.). London: Hogarth, 1970.

### **NODET, CHARLES-HENRI (1907–1982)**

Charles-Henri Nodet, a French psychoanalyst and psychiatrist, was born July 5, 1907, and died on March 20, 1982, in Bourg-en-Bresse.

On both his mother’s and father’s side, Nodet came from five generations of doctors. His mother was the daughter of the sculptor Cabuchet, who had a reputation locally. Heir to a lengthy Catholic bourgeois tradition, Nodet attempted to gain some distance from his background.

He was a brilliant student at school in Bourg-en-Bresse and later in the department of medicine in Lyon. He was first academically among his fellow medical clerks and, in 1932, obtained first place in the internship competition for the Asiles de la Seine, where his teachers were G. de Clérambault, P. Guiraud, and H. Claude, and his fellow students Henri Ey, Sacha Nacht, Daniel Lagache, Julien Rouart, and Jacques Lacan. Among the patients was Antonin Artaud, about whom Nodet wrote in a memo of April 1938: “His literary pretensions may be justified to the extent that the delusion may serve as an inspiration.” His medical dissertation, completed in 1936, was on “chronic hallucinatory psychoses.” He attended the philosophy courses given by Jacques Maritain. He received his license to practice psychiatry in 1937, again in first place. He married Isabelle Blanquet du Chayla at the end of 1943; they had three children.

When he returned to Bourg-en-Bresse in 1939 as a psychiatrist, he knew little about psychoanalysis. What changed his mind was a transference episode that was almost a caricature of the concept. While treating a hysterical paraplegic patient who was his mother’s age, he claims he was amazed to find that, after the third interview, the patient was able to move her limbs, while stating to him, “You’re a genius. I’m healed, but, I don’t know how to say this, I’m in love with you!” From 1947 on Nodet began to undergo treatment with Charles Odier, Raymond de Saussure, and Michel Gressot, and in 1964 became the first—and the only one at the time—provincial member of the Société psychanalytique de Paris (Paris Psychoanalytic Society). He practiced psychoanalysis from 1951 until 1982, the year of his death.

Nodet was a prolific author, some of whose articles were “pedagogical” in nature, designed to introduce psychoanalysis to members of the Catholic Church. His only book, published posthumously, is an anthology of his published essays together with some unpublished writing.

One of Nodet’s major contributions was that, while the unconscious is always an integral part of every

human activity, even the most apparently rational, analytic theory cannot be conceptualized “without reference to an implicit ideological presumption and a teleology of truth and ethics” (Oudot, R., 1982).

Nodet, more a clinician and practitioner than an innovative theorist, deserves a place in the history of French psychoanalysis for a number of reasons. Being the only provincial exemplar for years, he attracted a number of future analysts—some of whom are fairly well known—to his practice. In 1958 he co-founded the Groupe Lyonnais de Psychanalyse (Lyon Group for Psychoanalysis). He conducted clinical and theoretical seminars and provided technical supervision to individuals and groups.

It has also been said that Nodet had “demonized” psychoanalysis among the hierarchy of the Catholic Church. But he remained true to his profession, and did so without making any concessions, without obscuring the theoretical content of the discipline.

MARCEL HOUSER

*See also:* France; Religion and psychoanalysis.

### **Bibliography**

- Nodet, Charles-Henri. (1953). À propos du journal de Nijinsky. *L'Évolution Psychiatrique*, 38, (4), 695–710.
- . (1954). Névrose et vie religieuse: La névrose en tant qu'obstacle à la vie, et la névrose, conséquence de l'inhibition religieuse. *Praxis, Revue Suisse de Médecine*, 43, 32.
- . (1957). Psychanalyse et sens du péché. *Revue Française de Psychanalyse*, 21, 791–805.
- . (1958). Quelques réflexions sur les valeurs engagées dans la cure psychanalytique. *Revue Française de Psychanalyse*, 22 (3), 343–359.
- . (1982). Sciences humaines et religion. In *Psychanalyse et expérience humaine*. Paris: Le Cerf.

## **NONVERBAL COMMUNICATION**

The question of nonverbal communication involves two distinct areas of epistemology whose theoretical and clinical characteristics have, as of 2005, yet to be articulated: a developmental and linguistic field and a psychoanalytic field. In terms of developmental issues, Frédéric François notes that the body has been largely

overlooked by theoreticians of meaning, language, and communication. Understanding facts often begins with an understanding of the final state of their ontogenesis and it is only afterwards that we can retroactively investigate the roots, foundations, and precursors of the object of study. According to François, “It may be the descriptions of the final state that enable us to begin with well-formed utterances, with syntax, and then go on to examine their semantics, whatever it is those utterances may want to say and, ultimately, of the pragmatics, of the reasons for saying, of what it is that urges us to speak and what we are doing when we speak. And although it is true that linguistics has followed this sequence in its development, it is just as true that the child follows the opposite sequence.” In other words, it is the result of a natural process in the history of understanding that structural linguistics has developed (Ferdinand de Saussure) before what is currently known as subjectal or dynamic linguistics, which makes greater use of preverbal levels of communication.

Today it is obvious that work on the development of language in children essentially involves an investigation of its corporeal roots, whether these are found in the work of pragmatists (John Austin, Jerome Bruner), cognitivists (C. Trevarthen), or those interested in suprasegmental elements of the speech chain (Ivan Fonagy). All of them attach great importance to deepening our understanding of the preverbal communication that precedes the development of verbal communication, but which accompanies it, shadowlike, throughout life.

For neurophysiology, verbal communication, often referred to as encoded or digital communication, serves an analytical function and is primarily supported by the major hemisphere (involving the integration of the “twofold articulation” of language into phonemes and monemes described by André Martinet), while preverbal communication, known as suprasegmental or analogical, is said to serve a more global and holistic function, and is principally supported by the minor hemisphere (integration of behavioral communication and the music of language: prosody, rate of speech, rhythm, timbre, intensity, and so on, all of which are elements that constitute the nonverbal component of verbal speech).

In terms of psychoanalysis, the history of research on nonverbal communication is superimposed on the history of the concept of counter-transference to the

extent that the latter is essentially grounded in a more or less archaic level of emotional communication. From this point of view so-called preverbal communication refers as much to bodily communication, mimicry and behavior, as it does to the unencoded element of language.

It was primarily Melanie Klein who exposed this field of study by her introduction of the concept of projective identification. The importance that the post-Kleinian movement accorded to the process of counter-transference is well known. For rather than being considered an obstacle to therapy, counter-transference was treated as a fundamental tool for working with the patient, regardless of his or her age. Wilfred Bion, through concepts like the “mother’s capacity for reverie” and the “alpha function,” did much to improve our understanding of these primitive levels of communication, which come into play in group dynamics and in the minds of psychotic subjects. Bion’s model was then used for investigating the development of the mental life of the infant.

Julia Kristeva studied the suprasegmental elements of the language of depressive patients. Guy Rosolato, through his concept of “metaphoric-metonymic oscillation,” tried to take into account the modalities of the transition between representations of things and representations of words, or, ultimately, between unconscious systems and preconscious-conscious systems, modalities that would clarify the different levels, analog and digital, of communication. Gradually, and in parallel with this work, affect began to assume the function of “representance” (André Green), which acts directly as a medium for nonverbal communication.

At present it is in the investigation of analytic therapies for very young children or patients presenting archaic pathologies that the work of developmental psychologists (Daniel N. Stern) and psychoanalysts finds common ground. Nonetheless, research on nonverbal communication has become a central part of therapy for all patients, even adult and neurotic patients.

BERNARD GOLSE

*See also:* Alpha function; *Amae*, concept of; Counter-identification; Empathy; Identification; Infans; Infantile psychosis; Infant observation (direct); Maternal reverie, capacity for; Primary object; Projective identification; Telepathy.

### **Bibliography**

- Bion, Wilfred R. (1967). *A Theory of Thinking*. In *Second Thoughts*. London: Heinemann. (Reprinted from *International Journal of Psycho-Analysis*, 43, (1962), 4–5.)
- Fonagy, Ivan. (1983). *La Vive Voix: Essais de psychophonétique*. Paris: Payot.
- Green, André. (1973). *Le Discours vivant. La conception psychanalytique de l'affect*. Paris: Presses Universitaires de France.
- Klein, Melanie. (1946). Notes on Some Schizoid Mechanisms. *International Journal of Psycho-Analysis*, 27, 99–110. (Reprinted 1975. In *The Writings of Melanie Klein, III, 1946–1963*, pp. 1–24). London: Hogarth Press.
- Kristeva, Julia. (1989). *Black sun: Depression and melancholia* (Leon S. Roudiez, Trans.). New York: Columbia University Press. (Original work published 1987)

---

## **NORTH AFRICAN COUNTRIES**

Psychoanalysis is practiced in some North African countries, particularly Morocco and Tunisia. In Algeria it can be found in rare institutions. It seems never to have made an appearance in the remaining two North African countries (Libya and Mauritania). The presence of psychoanalysis is due to several factors: a French colonial past, cultural openness, multilingualism, the proximity of Europe, and the existence of several different trends in clinical psychiatry. However, psychoanalysis remains relatively undeveloped in spite of a genuine need to help a generation that suffered the effects of social violence and upheaval in the 1990s.

Morocco was the only North African country exposed to psychoanalysis during the colonial period. It was introduced by René Laforgue in 1948 when he went into exile with a group of friends and analysands, who were then joined by practitioners already practicing in the country (Jean Bergeret, Maurice Igert, Monique Foissin, and Louis Clément). Laforgue postulated the existence of radical structural differences among different peoples, ethnic groups, religions, and races. These nationalistic theories were far removed from North African preoccupations and were rejected by North African practitioners. Some of his students occupied positions of responsibility in hospitals (Igert, Clément, and Rolland) and contributed to introducing psychopathology to Morocco.

Because of the existence of a structured school of psychiatry under the patronage of Antoine Porot and the absence of psychoanalysts working in institutions, Algeria remained untouched by psychoanalysis during the colonial period. Nonetheless, three analysts set up practice there during the 1950s.

Though Angélo Hesnard was mobilized and stationed at Bizerte, Tunisia, in 1940, his stay there did not contribute to introducing psychoanalysis to the country. Institutional psychotherapy was introduced by Frantz Fanon, a politically committed psychiatrist who worked in Algeria in 1953 and Tunisia in 1956. Psychoanalysis began to take root in Tunisia in the 1960s as a result of the work of Lydia Torasi, an Italian psychologist-psychoanalyst.

After Morocco gained its independence in 1956, Laforgue and the other members of his group progressively returned to France. Some, like Clément and Legrand, delayed longer than others. During this period the first Moroccan psychoanalyst, Leila Cherkaoui, commenced work in 1969, followed by Smiljka Sif and Mohamed Abed. In the 1980s a new wave of French-trained psychiatrists and psychologists reintroduced psychoanalysis in the public and private sectors. Of special note are Jalil Bennani, Monique Kasbaoui, Ghita El Khayat, and Mohammed Fouad Benchekroun.

When Algeria became independent in 1962, most French psychiatrists left the country and local talent such as Khaled Benmiloud and Mahfoud Boucebcı began to develop psychiatry. The latter helped open up treatment centers to psychoanalysis. Although not a psychoanalyst, Boucebcı used some psychoanalytic concepts in his writings. Prominent psychoanalysts during the 1980s were Boubker Gouttali and Lotfi Benhabib, the latter of whom created the first psychoanalytic institution for children.

The same period in Tunisia saw the appearance of Tunisian practitioners (Samia Attia, Saïda Douki, Fakhredinne Haffani, Essedik Jeddi, Taoufik Skhiri, Khalifa Harzallah) and the integration of psychoanalysis in training centers and institutions. Although these therapists do not all practice as psychoanalysts, an element of psychoanalysis is present in their writings and practices.

As of 2004, North Africa had no developed psychoanalytic institutions similar to those in Europe and North America. Nonetheless, work groups and individuals

practicing in the public and private sectors contribute to transmitting and developing psychoanalysis in North Africa; psychoanalytic thought exists as a frame of reference for many clinical psychiatrists and psychologists; and practitioners affiliate themselves with different psychoanalytic trends. Not all the work of these practitioners has been published, so an inventory of current research cannot be exhaustive.

In Morocco, Jalil Bennani, a psychiatrist and psychoanalyst, was the driving force behind the creation of the association *Le texte freudien* (The Freudian Text) in 1985 and the *Association marocaine de psychothérapie* (Moroccan Association for Psychotherapy) in 1992. For three years the first of these organizations brought together all who were interested in psychoanalytic texts, whether practitioners or not. The second consisted of several commissions, including one devoted to psychoanalysis. Studies published during the 1980s and later deal with a variety of questions, such as circumcision (Mohammed Fouad Benchekroun), bilingualism (Jalil Bennani), the role of the father (Dachmi), and cultural resistance (Ghita El Khayat).

In Algeria, Loufti Benhabib and Abdelhag Benounich created the *Association de formation continue en santé mentale* (Association for Ongoing Mental Health Training) in 1988 and organized psychoanalytic training seminars and symposia, to which practitioners from abroad were invited to attend. In 1994 the association had to suspend its work because of the political situation. In 1989 clinical psychologists Mohand A. Aït Sidhoum, Fatima Arar, and Djamilia Haddadi founded the *Société algérienne de recherches en psychologie* (Algerian Society for Psychological Research). This society launched the journal *Psychologie* (Psychology) and the book series “Sémailles” (Seeds) with a view to disseminating psychoanalytic thought, and in the 1990s it was studying how to establish psychoanalytic training complying with the requirements of the International Psychoanalytical Association. Earlier publications worthy of attention are Mahfoud Boucebcı’s work on individual and family psychopathology and on children in traditional environments.

In Tunisia, the *Société d’études et de recherches en psychanalyse* (Society for Psychoanalytic Study and Research) formed in 1990 around Mohamed Halayem, the child psychiatrist and psychoanalyst. It uses seminars and supervised groups to introduce young psychiatrists and psychologists to psychoanalytic theory

and practice. Among available studies, Mohamed Ghorbal's work on the oral nature of communication in North African society is of particular interest. Also worthy of note are Saïda Douki's research on depression and suicide, Essedik Jeddi's studies of the family and psychosis, and Mohamed Halayem's study of semantics. But this society had only a brief existence.

In 1998 another Tunisian, Riadh Ben Rejeb, founded the *Unité de Recherche en Psychopathologie Clinique* (URPC) [Unit for Clinical Research in Psychopathology] and began to organize annual international meetings around various themes. Training in psychoanalytic psychotherapy, in individual psychoanalytic psychodrama, and analysis is organized through conferences, seminars, and psychoanalytic treatment. Neither a training institute nor a society per se, the range of its courses and activities remains restricted, creating an intellectual climate informed by psychoanalysis but not a culture of analytic learning. Psychoanalysis has had a salutary effect on the training of Tunisian physicians with respect to infant and adolescent psychopathology, but the country is still without a psychoanalytic institution.

Psychoanalysis is thus established in North Africa, and institutions in the region are studying how to open up new orientations and promote new initiatives in analyst training.

Also worth mentioning is the work of researchers outside North Africa whose writings have contributed to a greater awareness of psychopathology and psychoanalysis in North Africa. Of note is Fethi Benslama's work on Islam and psychoanalysis and on the role of the father, the individual, and sacrifice. Malek Chebel continues to research the Arabo-Muslim imagination, the body, love, and seduction. Daniel Sibony has studied how fundamental texts structure mentalities, but his interpretations concerning the community of believers in Islam have received much criticism. Many authors, whether North African (such as Zhor Benchemsi, Mohand Chabane, Okba Natahi, and Abdesselem Yahyaoui) or non-North African (for example, Jacques Hassoun, René Kaës, Olivier Douville, and Jean-Michel Hirt), have studied exile and migration. Research that focuses on North Africa is characterized by fruitful and sometimes contradictory debates and ongoing questioning reflecting the unique character of North Africa, its relationship with foreign languages (which are sometimes rejected and sometimes reap-

propriated), and questions of identity specific to each North African country.

JALIL BENNANI

### **Bibliography**

- Bennani, Jalil. (1996). *La psychanalyse au pays des saints*. Casablanca, Morocco: Fennec.
- Benslama, Fethi. (1988). *La nuit brisée*. Paris: Ramsay.
- Boucebci, Mahfoud. (1982). *Psychiatrie, société et développement*. Algeria: SNED.
- Chebel, Malek. (1993). *L'imaginaire arabo-musulman*. Paris: Presses Universitaires de France.
- Ghorbal, Mohamed. (1981). La personnalité maghrébine, psychogénèse. *Information psychiatrique*, 57 (4), 441–449.

---

## **NORWAY**

Psychoanalysis has throughout its history in Norway had strong connections with both the psychiatric health-care system and with academic psychiatry and psychology.

In 1905, Ragnar Vogt, who was to become the first professor of psychiatry in Norway, referred to the “psychocathartic” method of Freud in his psychiatric textbook, *Psykiatriens grundtrek* (An outline of psychiatry). Freud (1914d) referred to this as the first textbook of psychiatry to refer to psychoanalysis. It was not until the 1920s, however, that psychoanalysis was practiced in Norway, first and foremost under the leadership of Harald Schjelderup, who was from 1928 professor in psychology at the University of Oslo.

Schjelderup and several others went to central Europe for training, and psychoanalysis was established as a clinical discipline over the course of the 1930s, although there were intense debates and at times heavy opposition from the medical and clerical establishments. In the cultural field psychoanalysis was discussed both theoretically (the Freud-Marx debate) and on the practical and political level in the struggle for a healthier attitude toward sexuality. The latter was spear-headed by the journal *Sexual Information*, published by Karl Evang, later the surgeon general in Norway.

On August 22, 1931, a group of Scandinavian psychoanalysts gathered in Stockholm to establish a study-circle of psychoanalysts, with the aim of seeking an affiliation with the International Psychoanalytical Association (IPA). In 1933 a Nordic psychoanalytic society was formed with Alfhild Tamm from Sweden as president and Schjelderup as vice-president. At the Luzern congress in 1934, it was decided to establish a Danish-Norwegian and a Finnish-Swedish society, following a heated debate on the subject of unscientific analysis. This debate stemmed in part from the fact that Wilhelm Reich came to Oslo in 1934 at the invitation of Harald Schjelderup. Ernest Jones, the president of IPA, set the condition that Wilhelm Reich was not to be member of the Danish-Norwegian society. This was unacceptable as a condition, but Reich was nevertheless rejected for membership by society vote. The Danish-Norwegian society (soon altered to Norwegian-Danish because of the limited participation from Denmark) was then established, with Harald Schjelderup as president and Otto Fenichel as secretary. Fenichel had arrived in Oslo in 1933 and stayed until 1935. The first years of organized psychoanalysis in Norway were then marked by the struggle between the forceful personalities of Fenichel and Reich. This created a split in the milieu. The battle, which also engaged the medical establishment and the public, was centered on Reich's development of character-analysis, "vegetotherapy," and his quasi-scientific discoveries of the energy of life. Reich was ordered to leave Norway in 1939. His work on character-analysis has, however influenced psychoanalysis and psychiatry, and especially child-psychiatry through the work of Nic Waal.

When Germany occupied Norway, it was decided to temporarily dissolve the psychoanalytic society, to avoid being seen in Germany as interfering with the Nazi regime. Most of the members of the society participated in the resistance movement or in other defensive activities. Harald Schjelderup, as leader of the resistance at the university, was sent to the Grini concentration camp, near Oslo, and several others were forced to flee. Landmark died in violence in northern Norway, and P. Bernstein died in a concentration camp in Germany.

The temporary dissolution during wartime was not intended as a resignation from the IPA, but was treated as such by IPA authorities. The pioneers Schjelderup, Braatøy, and Simonsen re-established the Norwegian-Danish society in 1947, and it continued until 1953

when the Danes started their own organization. They were accepted as a component society in 1957 but it was not until 1975 that the Norwegian society received this status. The reason for the exclusion after wartime has not been established, and there is no official documentation that such an exclusion occurred. It was, however, obvious that the shadow of Wilhelm Reich's influence was a disadvantage for membership. An application made at the XVIII congress in London in 1953 was turned down with the argument that there were some members of the group who did not practice psychoanalysis, obviously referring to people seen as followers of Reich. The Norwegians argued that it was impossible to break with colleagues with whom one had resisted during the war. There followed a long struggle for recognition, with applications made at different congresses. One problem was the limited practice of Schjelderup, who maintained few sessions a week in training analysis, with the express purpose of increasing the educational capacity (he also claimed good results). In 1971 the Norwegian society was given status as a study group, and it finally regained status as component society in 1975 (Alnæs, 1994).

The Norwegian Psychoanalytic Institute had already been established in 1967 under the leadership of Peter Andreas Holter and the formal recognition by IPA gave impetus to an expansion of its activities, with a responsibility for psychoanalytic education being at the center. In later years other activities have seen increased focus, including research, teaching, and lecturing. The institute publishes the *Scandinavian Psychoanalytic Review* in collaboration with the other Scandinavian societies.

The modern Society has more than fifty members and still more candidates. There is an active child-analytic group and a group working with psychoanalytic research. The main trend is a broad object-relational approach with emphasis on analysis of character, along with some inspiration from ego-psychology.

The most significant figures in Norwegian psychoanalysis have contributed in a variety of capacities. Harald Krabbe Schjelderup (1895–1974) was the main pioneer of psychoanalysis in Norway. His numerous publications on psychoanalysis include, *Neurosis and the Neurotic Character* (1940) and "Lasting Effects of Psychoanalytic Treatment" (1957). Trygve Braatøy (1904–53) trained in Berlin. He worked at the Menninger clinic, 1949–1951, and was clinical director of a psychiatric hospital in Oslo. His publications include



*Foundation of Psychoanalytic Technique* (1954). Hjørdis Simonsen (1899–1980), perhaps the most important figure in the 1930s and after the war, was trained in Berlin, and later worked as a training analyst. Nic Waal (1905–1960), trained in Berlin and became a child psychiatrist. Finn Hansen (b. 1918), trained in Berlin and worked as training analyst. Peter Andreas Holter (b. 1927), a training analyst, was the first leader of the institute.

SVERRE VARVIN

### **Bibliography**

- Alnaes, Randolf. (1994). Psychoanalysis in Norway. History, training, treatment, and research. *Nordisk Journal of Psychiatry*, 32, 48.
- Braatøy, Trygve. (1954). *Fundamentals of psychoanalytic technique*. London: Wiley.
- Freud, Sigmund. (1914d). On the history of the psychoanalytic movement. *SE*, 14: 1–66.
- Schjelderup, Harald K. (1957). Lasting effects of psychoanalytic treatment. *Psychiatry*, 18, 109–133.

## **NOSTALGIA**

Nostalgia (*Sehnsucht*) refers to the moral pain of the expatriate when he is overcome with the obsession of return. The self-absorption, morosity, and feeling that there is nothing more to say about the situation are the first clinical manifestations of a secret torment that is likely to become aggravated. A state of desolation and physical malaise is soon established, which is fertile ground for infection and functional disorders, as if the subject's vitality had been sapped. In eighteenth- and nineteenth-century medical practice, this feared diagnosis went hand-in-hand with a grim prognosis.

The word is a neologism that appears for the first time in a medical dissertation written in Latin in Basel on June 22, 1688. It records, in academic language, what was then commonly referred to as “homesickness,” or *Heimweh*. Johannes Hofer's thesis is based on two clinical histories: a student from Bern who wasted away in Basel, and a servant who, after an accident, wasted away in the hospital far from her family. In both cases the patient was in agony and the return to

the family home resulted in a nearly miraculous cure. He proposed an interpretation based on the movement of animal spirits to account for the pathological phenomena.

Hofer described a new disease, unknown to Hippocrates and Galen, one that had become the subject of debate in departments of medicine throughout Europe. There was concern that the illness may have been unique to the Swiss, associated with the geographical isolation of mountain life or the physiological effects of migration to low-altitude regions. There had been cases of nostalgia among the Swiss regiments serving the king of France, and among foreign soldiers. There was, for example, a grenadier from Westphalia who had been consumed by *Heimweh*, which negated the idea that the illness was confined to mountain dwellers.

Although nostalgia was a medical discovery, it also held the interest of philosophers. Haller wrote an article on the subject for Diderot's *Encyclopaedia*. Rousseau, in his *Dictionnaire de la musique*, described a certain melody, the “Ranz des Vaches,” that had the power to trigger an epidemic of nostalgia and desertion among the Swiss garrison at Versailles. Kant believed that nostalgia was not a disease of exile but of poverty, and that territorial ties could be overcome through social success and wealth. Later, Jaspers, in his medical dissertation showed how *Heimweh* could turn young adolescents who left home too early into criminals or delinquents.

A century after the Basel dissertation, circumstances contributed to a new clinical understanding of nostalgia. Between 1789 and 1815, the number of cases multiplied, especially among emigrants and soldiers away from home. Military doctors developed clinical experience and therapeutic skills, as shown in the writings of Percy, Des Genettes, and Larrey. They learned how to recognize the feverish language and false sense of shame of the true nostalgic, and developed a form of psychotherapeutic treatment that pushed the patient to recall the “pleasant memories” of home, in his own language if possible. “The treatment of essential nostalgia,” wrote Baron Percy, “should be moral rather than pharmaceutical. It has been shown by experience that the administration of medicines does more to aggravate the symptoms than to relieve them.”

After 1830 the triumph of the anatomical-clinical method would gradually discredit the diagnosis of

nostalgia. Medical progress was based on the examination of lesions of organs and the identification of infectious germs, but autopsies and microscopes revealed nothing about the obsession with a return to one's home. Within a period of fifty years the word nostalgia disappeared from the medical lexicon. At the same time it made its appearance in literature, where it then referred to a romantic emotion and not a disease: the sadness of being born too late, the sense of exaltation occasioned by the setting sun when there was no hope of a tomorrow.

Rousseau's comments concerning the strange power of a melody that wiped away the bravura of the Swiss soldiers introduced nostalgia to the stage of history. Did the “Ranz des Vaches” have any special musical properties? No, Rousseau answers, but it is a “sign of remembrance.” There is nothing special other than a symbolic value for a native of the Swiss mountains. It suddenly restored to the abandoned and much regretted countryside a sonorous and impalpable presence, the mysterious presence of absence.

Several observations have confirmed the role of sound (a melody, a sound, a voice) in homesickness, either as a pathogenic agent that increases the pain of absence, or as a therapeutic factor that can instantly bring about remembrance. The subtleties of this intimate and subjective logic have been repressed by the progress of scientific medicine and its apology for the visible, from Bichat to Charcot.

The historian can approach the rise and fall of the diagnosis of nostalgia in the evolution of medical thought as a precursor to psychoanalysis. Within this tradition (about which Freud says nothing), it is interesting to note the points of divergence: the nostalgic individual suffered from remembrance, the hysterical patient from reminiscence. Attention has been shifted from conscious expressions of memory, involving a return home, to a veiled mnemonic utterance, often truncated or falsified, which infiltrates all speech and constitutes the first model of the unconscious.

However, psychoanalytic research on object loss has paid scant attention to attachment to the spaces and places of childhood, as if confirming Kant's arguments, which gave nostalgia a dimension that was more temporal than spatial: not a lost country but a lost time; the nostalgic individual would never rediscover his youth.

The paradox remains, however, that at a time when “displaced persons” are so numerous and when the findings of medicine and psychiatry have revealed a number of pathological phenomena related to the illnesses of migrants, the concept of nostalgia has been erased, except to sometimes refer to a miniscule and captivating territory, the maternal breast.

ANDRÉ BOLZINGER

*See also:* Abandonment; Cathexis; Ethics; *Future of an Illusion, The*; Music and psychoanalysis; Reparation; Subject's desire; Thing, the; Weaning.

### Bibliography

Bolzinger, André. (1989). Jalons pour une histoire de la nostalgie. *Bulletin de psychologie*, 389, 310–321.

———. (1992). Retour à la nostalgie. *Bulletin de psychologie*, 405, 331–340.

Grinberg, Léon, and Grinberg, Rebecca. (1986). *Psychoanalytic Perspectives on Migration and Exile* (Nancy Festinger, Trans.). New Haven, CT: Yale University Press.

Starobinski, Jean. (1966). Le concept de nostalgie. *Diogenes* 54, 92–115.

---

### “NOTE UPON THE ‘MYSTIC WRITING PAD’, A”

In this “note” written in the fall of 1924 and published in 1925, Freud justified a hypothesis he had made “long had about the method by which the perceptual apparatus of our mind functions” (p. 231), but that had remained unformulated until then. He hypothesizes that “cathectic innervations are sent out and withdrawn in rapid periodic impulses from within into the completely pervious system Pcpt.-Cs. So long as that system is cathected in this manner, it receives perceptions (which are accompanied by consciousness) and passes the excitation on to the unconscious mnemonic systems; but as soon as the cathexis is withdrawn, consciousness is extinguished and the functioning of the system comes to a standstill” (p. 231).

The operations of the memory apparatus are here the center of Freud's proposition. Human memory expresses or reveals the dual “magical” capacity of our mental apparatus for unlimited receptivity and the preservation of durable traces, though deformed or altered. While the writing instruments available at the

time (sheets of paper or slate) had shown themselves incapable of representing these functions, the “mystic writing pad,” which was marketed in the 1920s, could be used to illustrate the contradictory operation.

The pad was made of a piece of resin or wax, covered with a transparent sheet attached to its top edge, containing two layers that could be separated except along their top and bottom edges. The upper layer was a transparent sheet of celluloid and the bottom layer was made of thin, waxed paper. Whatever was written on the pad could be erased by separating the wax pad and the cover sheet without losing the initial writing. The analogy between this device and the mnemonic apparatus can be then be understood: celluloid/stimulus shield of the mental perceptual apparatus, waxed paper/Pcpt.-Cs., wax pad/unconscious, memory traces that cannot be reactivated except with “appropriate illumination.” The mystic writing pad satisfies the impossibility of combining two opposite functions. The sheet of paper will never be a slate, but the mystic writing pad is both, while it is never only one or only the other, but something quite different. By temporally combining what is spatially separate and by separating through spatial distribution what is temporally bound, the mystic writing pad offers the example of a paradoxical technique of writing. The psychic system—better than the mystic writing pad, which is unable to reproduce from within the writing that has been erased—does so, according to Freud, “as if the unconscious, by means of the Pcpt.-Cs. system, extended in the direction of the outside world antennas that, after they have sampled the excitations, are quickly withdrawn.” The discontinuous work of the Pcpt. Cs. system, cathexis and de-excitation, would explain the appearance of time.

In his “note” Freud confirms that there is no reason to have confidence in our memory. Not because it is supposedly a limited method for recording experiences (the content of the Pcpt-Cs system) as a momentary and continuous recording involving a continuous spatial dislocation, or, in contrast, as a durable but limited recording, which it is not. Rather, it is because it procures durable traces at the same time as it receives new imprints, and that it is imperfect whenever it is no longer limited.

The Freudian defiance of memory is contrasted with an attitude of denigration that legitimates forgetting and ignorance and would, conversely, require a strengthening of his position. This attitude is not

established on the basis of the functional imperfection of memory, assumed to be lasting if it is compared to the durable imprints provided by paper or the renewable imprints afforded by slate. To overcome the challenge, the functionality of the mnemonic apparatus must be accurately represented. The “mystic writing pad” helps illuminate its operation.

The value of this note implicitly touches upon the goal for psychoanalysis that Freud had indicated as being like “draining the Zuider Zee”: bringing to light the ego rather than the id (see “The Decomposition of the Psychic Personality” in 1933a [1932]) and working through the unconscious repressed. The mystic writing pad offers the example of a dualistic and opposed mnemotechnical function that is carried out without disturbance, allowing the metapsychological representation of the mnemonic psychic apparatus and illustrating its operation.

Since Freud, the suggested connection between the history of representation and theoretical models, and the future of technique would, according to some authors, relativize the relevance of Freudian topological subsystems. The computer and the virtual image have come to require us to present a different model, for our referent is no longer the “mystic writing pad.” This has led Jacques Derrida to claim that the Freudian topographical subsystems of the psychic apparatus were part of a model that is no longer relevant. Freud, however, did not see his topographical representation as a model that was subordinate to technology.

DOMINIQUE AUFFRET

See also: Mnemic trace/memory trace; Protective shield; Time; Unconscious, the.

#### Source Citation

Freud, Sigmund. (1925a [1924]). Notiz über den “Wunderblock.” *Internationale Zeitschrift für Psychoanalyse*, 11, 1–5; A note upon the mystic writing pad. *SE*, 19: 227–232.

---

### “NOTES UPON A CASE OF OBSESSIONAL NEUROSIS” (RAT MAN)

Dr. Ernst Lanzer, alias the “Rat Man,” consulted Freud on October 1, 1907, and began an analysis that allegedly lasted a little more than eleven months and ended

in a complete cure. The patient's presenting symptoms were florid: Obsessions lasting from childhood had intensified most dramatically in the previous four years. In the recent past Lanzer's obsessional ideation involved lethal injury dealt to his girlfriend or even to his dead father. Lanzer also complained about compulsive impulses, such as cutting his own throat with a razor; he also described his personal prohibitions, which sometimes concerned quite trivial matters. As a result, procrastination affected both his personal and professional life, including the efforts to finish his legal education, to work, and to marry.

The importance which Freud attributed to the case of the “Rat Man” is revealed by these facts: During its duration, he gave four “progress reports” to the Vienna Psychoanalytic Society; he made it the subject of his lecture at the First International Congress of Psychoanalysis in Salzburg; and it was the only case for which he retained day-to-day process notes. In sum, since Dr. Lanzer had previously consulted Wagner-Jauregg, Vienna's most famous psychiatrist, Freud was moved to make the case a psychoanalytic showpiece, much as he was later to do with the “Wolf Man,” who had previously seen the leading psychiatrist in all Europe, Emil Kraepelin. During his second hour on the couch Lanzer recounted an incident that was the origin of his famous pseudonym.

While on maneuvers the previous summer, he lost his pince-nez; subsequently on the same day he heard a “cruel captain” describe an Asian torture in which a heated pot containing live rats is applied to the buttocks of the intended victim. Upon hearing the sadistic story, the Rat Man imagined that the torture was being applied simultaneously to both his ladyfriend and to his father. To prevent the fulfillment of that fantasy, the Rat Man resorted to the defensive formula “But whatever you are thinking of,” accompanied by a gesture of repudiation. An immediate derivative of the rat story was Lanzer's crazed compulsions about reimbursing his military comrade who paid for his new pair of pince-nez, sent by post. Subsequently in Lanzer's mind, the rat, symbolically thriving in a colony of good and bad objects and their identifying features, could signify, among other things: the Rat Man himself, his mother, his girlfriend, babies, anuses, genitalia, money, the acts of gambling, marrying, devouring, penetrating, containing.

Freud's claim about completely restoring his patient's health is a notable exaggeration. However,

although carrying out conspicuous indoctrination, neglecting immediate transference reactions (especially of the negative kind), and diminishing the role of women in the Rat Man's analysis, Freud was able to achieve a measure of therapeutic success by focusing on and clarifying his patient's oedipal relationship to his father. In addition, Freud repeatedly demonstrated to his patient that his obsessional compulsions could be dynamically understood when their original wording was recovered. In sum, Freud was able to some degree to allay his patient's panic and render him more functional, both personally and professionally.

Although a classic psychoanalytic study of the obsessional-compulsive personality, the case has its own share of historical fictionalization. Lecturing before the Vienna Society Psychoanalytic on November 20, 1907, Freud boasted that the name of Lanzer's ladyfriend could be inferred from his anagrammatic, magically defensive prayers even though her name was not yet disclosed; Freud's process notes reveal that he learned it by October 27. Freud went on to discuss the case at the First International Psychoanalytic Congress in 1908; according to Jones's erroneous although generally accredited account, Freud lectured for an incredible five hours on the clinical material. On a more serious score, a minute comparison of Freud's process notes and their write-up in the case history shows that in critical places he lied, constantly giving the effect that the treatment lasted longer than it actually did.

There is also considerable confusion in Freud's write-up of his case history, which manifests a remarkable imbalance between its first and second parts. Anal eroticism and the reverberations of the rat story dominate the first, practical half of Freud's text; but in its second half there are but two incidental references to anality and one passing reference to the rat story. Freud had to wait four more years before gathering the insight into the etiological link between anal eroticism and obsessional neurosis. Thus, in his second section, Freud can only clarify such issues as the phenomenology and structure of obsessional ideas, the psychological significance of obsessional thinking, characteristic attitudes to superstition and death, and a non-phasic consideration of compulsion and doubt as originating in the drives.

In his private correspondence Freud recurrently called attention to the disconnectedness of his case, a textual feature mimetic of the disconnected nature of

his patient's perceptions and obsessions. Thus, Freud's expression, through counter-transference, was infected by its contents: obsessional neurosis, which, by severing causal connections (through defensive isolation), is a pathology that affects both the contiguity of psychic material and its expression. Accordingly, the very symptomatic nature of Freud's writing in his case history reveals several problems. He confused precipitating causes; he elaborated little on the links among heterosexual object choices in the patient's oedipal and preoedipal life; he did not harmonize his clinical and theoretical considerations; he did not integrate his explanatory principles of anality, ambivalence and economic theory; and finally, he omitted to neatly tie together his patient's child and adult symptomatology.

PATRICK MAHONY

*See also:* Act, passage to the; Ambivalence; Archeology, metaphor of; Compulsion; Construction-reconstruction; Death and psychoanalysis; Doubt; Dream screen; Face-to-face situation; Instinctual impulse; Intellectualization; Isolation; Lanzer, Ernst; Negation; Nuclear complex; Obsession; Obsessional neurosis; Omnipotence of thought; Organic repression; Rationalization; Symbolism; Technique with adults, psychoanalytic; Therapeutic alliance; Undoing.

### Source Citation

Freud, Sigmund. (1909d). Bemerkungen über einen Fall von Zwangsneurose (Der "Rattenmann"). *Jb. psychoanal. psychopathol. Forsch.*, 1, p. 357–421; *GW*, VII, p. 379–463; Notes upon a case of obsessional neurosis, *SE*, 10: 151–318.

### Bibliography

Freud, Sigmund. (1909d). Notes upon a case of obsessional neurosis. *SE*, 10: 151–318.

———. (1974a [1906–13]). *The Freud/Jung letters: The correspondence between Sigmund Freud and C. G. Jung* (William McGuire, Ed.; Ralph Manheim and R. F. C. Hull, Trans.). Princeton, NJ: Princeton University Press.

Mahony, Patrick. (1986). *Freud and the rat man*. New Haven, CT: Yale University Press.

———. (1993). Freud's oratorical marathon: The shrinking of another myth. *International Journal of Psycho-Analysis*, 74, 837.

## NOUVELLE REVUE DE PSYCHANALYSE

The *Nouvelle revue de psychanalyse* (New review of psychoanalysis), founded and headed by Jean-Bertrand Pontalis, was published in Paris by Éditions Gallimard from Spring 1970 to Autumn 1994. By 2004, over fifty collectively-authored volumes were published at the rate of two per year.

Despite the discreet indication found under the title, "published with the collaboration of the Association psychanalytique de France (APF; French Psychoanalytical Association)," the journal was not the official organ of any analytical institution and was not reserved, as a closed field, to analysts alone. The pluralistic composition of the editorial board explicitly manifests this: it was made up of Didier Anzieu, Guy Rosolato, and Victor Smirnoff, all analysts from the APF; André Green, an analyst from the Société psychanalytique de Paris (SPP; Paris Psychoanalytic Society); Masud Khan, a London-based analyst; Jean Pouillon, a scholar of philosophy and ethnology; and Jean Starobinski, a literary critic and scholar of intellectual history.

In the first issue (*Incidences de la psychanalyse* [Incidents of psychoanalysis]), Pontalis's opening article, "La question de la psychanalyse" (The question of psychoanalysis), announced the journal's guiding principles: Psychoanalysis, as a question, asks questions and allows questions to be asked of it; it questions itself, not within the closed "inside" circle of analysts, but in an open terrain of exchanges and confrontations with the other scientific disciplines. The journal did not erect uncrossable borders between analysts and nonanalysts: By being open to others, it opened up first to itself, to explore its own confines and limits (*Aux limites de l'analysable* [At the limits of the analyzable] was the title of the tenth issue).

Each issue focused on a theme, but these themes effected a kind of displacement in relation to the established repertory of psychoanalytic notions: for example, *The L'Espace du rêve* (The dream space) rather than "Le rêve" (Dreams), or *L'Amour de la haine* (The love of hate) rather than "Amour et haine" (Love and hate) or "Ambivalence." Each theme proposed an idea and its inherent instability, eliciting both reflection and perturbations in thinking. *L'Attente* (Expectation), *Dire* (Say), *Excitations*, *La Plainte* (Complaint), *Liens* (Connections) are commonplace words or expressions that, within the space of a collectively written volume,

become an open questioning of both theory and practice, on the part of both analysts and the “guests” from outside the field of analytic treatment proper who participated in producing almost all of the issues.

The *NRP*, as it came to be commonly known, always sought to remain open to the “strange” or foreign, not only by welcoming the work of authors who were foreign by virtue of their country, discipline, or institutional affiliation, but also by its resolve, in each issue, to effect the “test of strangeness,” an approximation of the alien dimension that inhabits the very thing of analysis as much as it does the desire of the subject who comes face to face with it. *L’Intime et l’Étranger* (The intimate and the strange), the title of one issue, refers to the horizons of its writing: what is proper to the psychoanalytic experience, in terms of both treatment and thinking, always being that which dispossesses us and transfers us to what does not belong to us. The choice of this theme was an occasion for confrontation and exchanges, a time to bring forth or invent perspectives that were new and disconcerting for the thinking of everyone, hosts and guests alike, all of them becoming hosts to the strangeness of the unconscious. The *NRP* was attentive to the international psychoanalytic scene, especially in English-speaking countries, as attested by its publication of the work of Masud Khan, Harold Searles, Robert Stoller, and Donald Woods Winnicott.

For many young analysts or analysts in training, this journal was a sort of workshop, a laboratory for psychoanalytic writing and thinking. The “argument,” elaborated by the editorial team made of up François Gantheret, Michel Gribinski, and Laurence Kahn (with Michel Schneider also a member from 1981 to 1988), was circulated among a group of authors, to provide an opening point for questioning and a stimulating deployment of the proposed theme. From 1983, the *Varia* or miscellany section, collected and edited by Gribinski, provided an open forum for ideas that were coming or waning, light or occasional pieces—in the manner of a log book for the working analyst indulging in reverie.

The success of this publication was broad-based and sustained, both in France and abroad, throughout its run. The *NRP* was able to claim and maintain an eminent place in the French psychoanalytic landscape, by means of the quality and depth of its theoretical and clinical reflection, and by the independence and originality of its thinking. In his preface to the “Cata-

logue 1970–1994,” Pontalis wrote: “Free of any institutional or university affiliation, and of allegiance to the word of any Master, the *Nouvelle revue de psychanalyse* has obeyed only one exigency: to make sensible, without erasing it, the life of the unconscious, to make its work intelligible without pretending to master it. It would like its past and future readers to be able to recognize in the movements of its thinking a bit of the approach of the Gradiva, who, supple and decisive, moves forward between the power of dreams and the attraction of life.” At the decision of its director, publication of the *NRP* ceased with the issue titled *Inachèvement* (Incompletion). The fifty volumes that constituted its written body were one of the places where the Freudian heritage was able to remain alive and, at the same time, be renewed. The *NRP*, with its successful creation and embodiment of a style, marked psychoanalytic thinking and practice in a decisive and lasting way.

EDMUNDO GOMEZ MANGO

See also: Association psychanalytique de France; *Documents et Débats*, France.

### Bibliography

- Gribinski, Michel. (1994). Avant-propos. In *Analyse ordinaire, analyse extraordinaire*. Paris: Gallimard, “Les varia de la *Nouvelle Revue de psychanalyse*,” p. 7–11.
- Pontalis, Jean-Bertrand. (1970). La question de la psychanalyse. *Nouvelle Revue de psychanalyse*, p. 5–8.
- . (1984). Le moment venu. *Nouvelle Revue de psychanalyse*, 30, 5–12.
- . (1994). Catalogue 1970–1994. *Nouvelle Revue de psychanalyse*.

---

## NUCLEAR COMPLEX

The expression “nuclear complex” was first used by Sigmund Freud to designate what he would later call the “Oedipus complex.” While still signifying from a genetic or structural point of view the universal Oedipus complex, the notion of the nuclear complex came to be used in the narrower perspective of psychopathology: this complex was described as the characteristic core of neuroses, and contrasted to pre-oedipal pathologies.

The term first surfaced in the text that Freud devoted in 1908 to the sexual theories of children. The child who, with mixed feelings, sees a little brother or sister arrive, “now comes to be occupied with the first, grand problem of life and asks himself the question: ‘Where do babies come from?’” (1908c, p. 212). Not very satisfied with the fallacious responses they get from adults, “children . . . have a suspicion of there being something forbidden which is being withheld from them . . . they consequently hide their further researches under a cloak of secrecy. . . . The nuclear complex of a neurosis is in this way brought into being” (pp. 213–214). The term *nuclear complex* in this text was very broadly described, suggesting an idea present since the beginnings of psychoanalysis, that of intrapsychic conflict.

From this moment forward, the definition became much more precise. Freud illustrated what he meant through the case of “little Hans,” who was the subject of an extended discussion the following year. In this case the Oedipus complex was very much in evidence, as well as its correlate, castration anxiety (1909b). That same year, Freud again used the expression “nuclear complex of the neurosis” in the case of the “Rat Man” (1909d), in which he said that it “comprises the child’s earliest impulses, alike tender and hostile, towards its parents. . . . It is entirely characteristic of the nuclear complex of infancy that the child’s father should be assigned the part of a sexual opponent” (p. 208n). Also in 1909, in the fourth of the *Five Lectures on Psycho-Analysis*, he tied it in specifically with the Oedipus myth. The term Oedipus complex, which was introduced in 1910, prevailed subsequently, with rare exceptions.

When the term *nuclear complex* appears in contemporary psychoanalytic literature, it is in reference to an early phase of Freud’s thought, and marks the central role of the Oedipus complex in neurotic pathology.

ROGER PERRON

See also: Oedipus complex.

### **Bibliography**

Freud, Sigmund. (1908c). On the sexual theories of children. *SE*, 9: 205–226.

———. (1909b). Analysis of a phobia in a five-year-old boy. *SE*, 10: 1–149.

———. (1909d). Notes upon a case of obsessional neurosis. *SE*, 10: 151–318.

## **NUMINOUS (ANALYTICAL PSYCHOLOGY)**

The term *numinous*, based on the Latin *numen* (“will, the active power of the divine”) was coined by Rudolf Otto (1917/1926) to define a “category for the interpretation and evaluation” of nonrational manifestations of the sacred. According to Otto, the numinous is characterized by a “sense of one’s creature state” (p. 10), mystical awe (*tremendum*), a presentiment of divine power (*majestas*), amazement in the face of the “completely other” (*mysterium*), demoniacal energy, and paradox.

Otto’s phenomenological method and the importance he granted to experience are congruent with the empirical approach of Carl Gustav Jung, who as a matter of course integrated this notion into his own field of research beginning in the 1930s (Jung, 1937–40). He had previously used the term *numen* to describe the autonomy of psychic energy, conceived in its most primitive sense, in relation to *mana* (spiritual power) (Jung, 1928b [1948], p. 233).

For psychology and psychotherapy, the numinous is a borderline concept that names and circumscribes certain dynamic and constraining psychic events through which the subject becomes linked to an object that is “completely other” and cannot be understood intellectually. Indeed, conscious will has no hold over the numinous object, which is experienced as indescribable and which “puts the subject into a state of amazement [being dumbstruck], or passive submission” (Jung, 1928b [1948], p. 186). The state of consciousness is altered, the mental level “lowered.” The numerous warnings from therapists about this effect are commensurate with the risks entailed: schizophrenic dissociation, inflation of the ego, fascination, or possession; as well as the broader social consequences of fanaticism and the “terrifying suggestibility that lies behind all mass movements” (Jung, 1942 [1948], p. 184).

However, based on his own experience of the collective unconscious during his self-analysis from 1913 to 1918 and on the dreams and visions of his patients, Jung believed that the numinous effect

could be therapeutic. Indeed, it signals the emergence of an archetype with specific energy or emotional charge, which can effectively compensate for the overly unilateral attitude of consciousness. For example, the numinosity of the archetype of the self “incites” man to realize the paradoxical totality of his being, conscious and unconscious, by means of the symbols of the quaternity that appear in dreams. In this case, the attitude of the ego is the determining factor. Jung described it as “religious,” in that sense that for him, religion (from the Latin *relegere*, or “send forth,” and not *religare*—“restrain”) was “a careful and scrupulous observation of ... the *numinosum*” (Jung, 1937–40, p. 7).

AIMÉ AGNEL

*See also:* Archetype (analytical psychology); Religion and psychoanalysis.

### **Bibliography**

- Jung, Carl Gustav. (1928b [1948]). On psychic energy. *Coll. Works* (Vol. 8). London: Routledge & Kegan Paul.
- . (1937–40). Psychology and religion. *Coll. Works* (Vol. 11). London: Routledge & Kegan Paul.
- Jung, Carl Gustav. (1942 [1948]). A psychological approach to the dogma of the Trinity. *Coll. Works* (Vol. 11). London: Routledge & Kegan Paul.
- . (1966). Theoretical considerations on the nature of the psyche. *Coll. Works* (Vol. 8). London: Routledge & Kegan Paul.
- Otto, Rudolf. (1926). *The holy: an inquiry into the non-rational factor in the idea of the divine and its relation to the rational* (John W. Harvey, Trans). London: Oxford University Press. (Original work published 1917)

## **NUNBERG, HERMANN (1884–1970)**

Hermann Nunberg, a physician and psychoanalyst, was born on January 23, 1884, in Bedzin, Poland, and died on May 20, 1970, in New York City. As a child, he was tutored at home until, after his mother’s death in 1896, he attended the college-preparatory school in Krakow, Poland. There he studied medicine for two years before continuing his studies in Zurich, where he obtained his medical degree in 1910.

While a student, Nunberg had met Eugen Bleuler and Carl Gustav Jung at the Burghölzli Psychiatric Clinic of the University of Zurich, and he worked on the latter’s word-association test. Nunberg began practicing psychiatry in Schaffhouse and Berne, Switzerland, and continued practicing at the university clinic when he returned to Krakow in 1912. In Switzerland he had belonged to the Zurich psychoanalytic group, and back in Poland he began teaching psychoanalysis at the Krakow psychiatric society in 1912.

In 1914, after moving to Vienna, Nunberg underwent a training analysis with Paul Federn. He worked at the university psychiatric clinic under Julius Wagner-Jauregg and joined the Vienna Psychoanalytic Society in 1915. At the fifth congress of the International Psychoanalytical Association, held in Budapest in 1918, Nunberg, with Freud’s consent, called for training analyses to be required for psychoanalysts in training. Viktor Tausk and Otto Bank strongly opposed this idea. After the training institute of the Vienna Psychoanalytic Society was created in 1925, Nunberg taught general neurology there for several years, publishing his lectures in 1932, which were later translated as *Principles of Psychoanalysis* (1955). Freud, in his preface to the book, wrote that it “contains the most complete and conscientious presentation of a psycho-analytic theory of the neurotic processes which we at present possess” (1932b, p. 258). He emphasized that Nunberg did not content himself with simplification or mere description of complex issues.

In 1932 Nunberg emigrated to United States, staying awhile in Philadelphia and finally settling in New York. He remained a member of the Vienna Psychoanalytic Society until its dissolution in 1938. In 1940 he joined the New York Psychoanalytic Society and served as its president from 1950 to 1952. In collaboration with Ernst Federn, Nunberg compiled the minutes of the Vienna Psychoanalytic Society (1906–1918), published between 1962 and 1975.

HAROLD LEUPOLD-LÖWENTHAL

*See also:* Depersonalization; Heroic self; Lehrinstitut der Wiener psychoanalytischen Vereinigung; *Minutes of the Vienna Psychoanalytic Society*; Training analysis; Wiener psychoanalytische Vereinigung.



**Bibliography**

Freud, Sigmund. (1932b). Preface to Hermann Nunberg's *Allgemeine neurosenlehre auf psychoanalytischer grundlage*. *SE*, 21: 258.

Mühlleitner, Elke. (1992). *Biographisches lexikon der psychoanalyse: die mitglieder der psychologischen Mittwoch-*

*Gesellschaft und der Wiener psychoanalytischen vereinigung von 1902–1938*. Tübingen, Germany: Diskord.

Nunberg, Hermann. (1955). *Principles of psychoanalysis*. New York: International Universities Press.

Nunberg, Herman, and Federn, Ernst (Eds.). (1962–1975). *Minutes of the Vienna Psychoanalytic Society* (4 vols.). New York: International Universities Press.

# O

## **OBERHOLZER, EMIL (1883–1958)**

Emil Oberholzer, a Swiss doctor who specialized in psychiatry and psychoanalysis, was born December 24, 1883, in Zweibrücken, and died May 4, 1958, in New York. He studied medicine and received his training in psychiatry from Eugen Bleuler in Zürich, beginning May 6, 1908. From February 1, 1911, to October 1, 1916, he was an assistant physician at the psychiatric clinic at Breitenau-Schaffhouse, then a physician at Dr. Brunner's sanatorium (Küsnacht, in the canton of Zürich). In 1919 he began working as a private practitioner in Zürich.

Oberholzer became friends with Hermann Rorschach and helped in developing the shape interpretation test; he continued work on the test and was considered one of its best interpreters. Most of his writing was devoted to the Rorschach test and its interpretation. As a member of the Zürich group, which was part of the International Psychoanalytical Association (IPA), he gave a presentation on November 3, 1911, on dream analysis.

After an initial analysis with Oskar Pfister, he began analysis with Freud in June 1913 and remained faithful to Freud following Carl G. Jung's defection. With his wife, Mira Ginzburg (1887–1949), a physician who was also analyzed by Freud, and Oskar Pfister, he created the Swiss Society for Psychoanalysis on March 21, 1919, and became its first president, a position he held until 1928.

He is important because he was the first person in Zürich, in fact the first person in German-speaking Switzerland, to be analyzed in the Freudian manner, with several weekly sessions over a period of several

years. He published relatively little on psychoanalysis, aside from two case studies of children (1922).

At the end of 1927 Oberholzer tried to resolve the conflict that had been developing within the Swiss Society for Psychoanalysis "because of analyses that had been enthusiastically shortened" (letter from Freud to Pfister, February 17, 1928) by Oskar Pfister. Because there was some confusion between Pfister's specific problem and the more general problem of "lay analysis," the Schweizerische Ärztgesellschaft für Psychoanalyse (Swiss Medical Society for Psychoanalysis), which he created in 1928, was not accepted into the IPA and was dissolved after a few years.

On March 25, 1938, Oberholzer emigrated to the United States, and escaped the threat of Nazi Germany, primarily out of concern for his Jewish wife and his son. The couple practiced psychoanalysis in New York (they were not licensed to practice there as physicians). After his wife's death in 1949, Oberholzer became increasingly isolated and died in 1958 after suffering for many years from diabetes.

KASPAR WEBER

*See also:* Burghölzli Asylum; Schweizerische Ärztgesellschaft für Psychoanalyse; Splits in psychoanalysis; Switzerland (French-speaking); Switzerland (German-speaking).

### ***Bibliography***

Freud, Sigmund; and Pfister, Oskar. (1963a [1909–39]). *Psycho-analysis and Faith; the Letters of Sigmund Freud and Oskar Pfister* (Heinrich Meng and Ernst L. Freud, Eds.; Eric Mosbacher, Trans.). London: Hogarth Press.

Müller, Max. (1982) *Erlebte Psychiatriegeschichte 1920–1960*. Berlin: Springer.

Oberholzer, Emil. (1922). Der Neurose entgegen. *Schweizerische pädagogische Zeitschrift*, 10 (32), 168–174.

———. (1922). Phobie eines sechsjährigen Knaben. *Schweizerische pädagogische Zeitschrift*, 18–21.

Weber, Kaspar. (1994). Gespräche mit Margrit Wettstein, die noch die Anfangszeiten unserer Gesellschaft erlebt hat. *Bulletin de la Société suisse de psychanalyse*, 37, 45–54.

## OBJECT

The concept of the object in psychoanalysis proves to be an enigmatic one, because of its mobile and polysemic aspect and constantly changing character; there always remains an unknown zone that nurtures the object-cathexis and is therefore necessary for its continuation. The object in psychoanalysis is constituted of fluctuating impulses of unconscious, preconscious, and conscious cathexes, that are exchanged on a reciprocal basis. The object is neither a thing or a person, nor the fantasmatic content or a bodily zone of that person, although it relates to these throughout the analytic work. The concept of the object is a tool of understanding for the analyst and a notion that would become meaningless if it were studied as an independently existing entity. It is the unconscious element that lends some continuity to the cathexis of the various kinds of representations that are evoked by the patients' words, provided that the analyst constructs this continuity through the bi-vocal melody to which he is listening. The term *object* can be used only from the moment when analytic work is possible, however early this may be (Diatkine, 1989).

There is a polysemy to the term *object*, as it flows into the part-object; the total, narcissistic, internal, and external objects; the self-object; the object relationship; object choice; and others. This semantic richness reflects the complexity of the connections to other people in the psyche; it also can lead to confusion.

In his study of the drives ("Instincts and Their Vicissitudes," 1915c), Sigmund Freud explores a connection between the object and the drive: the drive excitation comes from inside the organism (pressure) and it corresponds to a need that is assuaged by the satisfaction (aim of the drive). The object is therefore the means by which the drive can attain this aim. Freud already emphasizes, however, that the object is the most valuable element of the drive and also that is

it not intrinsically connected with it; the link is therefore something that has to be constructed. He adds that the object is not necessarily an unfamiliar object; it can be anything that is susceptible to cathexis, including therefore the subject's own body through the forms of auto-erotism (object-cathexis, narcissistic cathexis).

Between 1905 and 1924, Freud described a series of pregenital stages that are to be understood less in genetic terms than as something defined by partial (or component) drives; the satisfaction of each is linked with an erogenous zone (oral, anal, phallic), and thus also by their corresponding oral, anal or phallic object relationship. The concept of "part object" was introduced by Melanie Klein, but the concept of the "part" already exists in Freud within the "partial drive" concept. The object choice that unifies the sexual life under the aegis of genitality and orientates it definitively towards others does not therefore occur until puberty.

Freud went to on distinguish between two types of object: an object that relates specifically to the drive (a person, part of a person, a part-object, a fantasmatic object) and a total object, an object of love or hatred. At the very beginning of psychic life, the external world, the object, and what is hated are identical (the object emerges in hatred). When, following the purely narcissistic stage, the object is recognized as a source of pleasure, it can become an object of love, being loved and incorporated into the ego. In "Instincts and Their Vicissitudes," Freud writes that the terms "love" and "hatred" should not be used for the relation of drives to their objects but reserved for the relations of the total ego with the objects. The concept of "object choice" (object choice or narcissistic object choice) thus refers to the object of love or hatred and not to the object of the drive.

When Freud refers to the libido of the ego as opposed to the libido of the object, the object in this expression is understood in the restricted sense of an external object that does not include the ego; furthermore, it nevertheless clearly transpires that Freud generally focuses on psychic reality and the intrapsychic in his metapsychological theory. His theory of anaclysis required nothing more from the object than its necessity for ensuring self-preservation; here it was the child who was "responsible," based on the satisfaction of their bodily needs, for developing auto-erotisms in order to prepare for their existing and future sexuality.

However, Freud was evidently well aware “that there is no such thing as a baby without a mother” (as Donald Winnicott was later to say) when he wrote in *The Ego and the Id*, albeit in a footnote: “The effects of the first identifications made in earliest childhood will be general and lasting. This leads us back to the origin of the ego ideal; for behind it there lies hidden an individual’s first and most important identification, his identification with the father in his own personal prehistory (Perhaps it would be safer to say ‘with the parents’; for before a child has arrived at definite knowledge of the difference between the sexes, the lack of a penis, it does not distinguish in value between its father and its mother). This is apparently not in the first instance the consequence or outcome of an object-cathexis; it is a direct and immediate identification and takes place earlier than any object-cathexis” (1923b, p. 31).

How then should we understand the relation between the parents, or those who perform this function, as people, as against the father or mother as “objects” used in the psychoanalytic work? The psyches of mother and father clearly play an essential role in the creation of the human being’s representational system from the very beginning of life. By conferring a meaning on the very young child’s activity, the capacity for “maternal reverie” (Wilfred Bion) does not introduce this meaning into their psyche, but rather harmoniously or discordantly modulates stimulations and “calming” attitudes or temporary abandonments that are constructed by the child. The meaning given by the mother produces another meaning in the subject, each of which becomes interconnected in a process that is as complex as the process that gives rise to the bi-vocal melody in the analytic treatment.

Following on from Freud and Karl Abraham, Melanie Klein, in her study of archaic states of functioning, attributes to the psyche from the outset a primitive ego (self), an external-internal boundary, a (part) object and the capacity for splitting and projecting; like Freud, she uses footnotes to take account of external objects. With reference to Sándor Ferenczi, she notes that it may be that complex mechanisms (living organisms) cannot continue as stable entities independently of the influence of external conditions. When these conditions become unfavorable, the organism disintegrates. “Integration and adaptation to reality depend essentially on the infant’s experience of the mother’s love and care.”

Donald Winnicott, a contemporary of Klein and a highly innovative author who theorized the bond between object and subject, attributes prime importance to the object’s response in the creation of this vital illusion to be shared between mother and child, namely the transitional space, of which the transitional object is only one of the signs. The “use of the object” is at the heart of this author’s concerns and he gives precedence to the access to subjectivation, “*first being*,” over the economy of drives. For him, this hallucination occurs in response to the increase in tension, always independently of the reality of the object; the problem of primary binding (that is, the object’s binding of the hallucination or the drive excitation) arises as follows: if the object is absent, the drive excitation and the hallucination are dealt with either by evacuative discharge or by a mode of binding and fusion *in statu nascendi*, primary masochistic binding. It is essential that the object’s absence or separation (creating the excitation) should not continue for a period that exceeds the subject’s capacities to re-establish through the hallucination the psychic continuity that is necessary to the sense of continuity of being. If, on the contrary, the object is present and if its response is “granted” to this hallucinatory process, it instigates the “created-found” aspect of the object and the transformation of the hallucination into an illusion. The threat that will inevitably be posed to the primary illusion (the lover’s censure, decrease in primary maternal concern) then triggers an upsurge of destructivity connected with distress and rage at the object’s lack of attunement. It is here that Winnicott introduces a further element into the theory: whereas classically the object was discovered in hatred as a result of frustrations, Winnicott accords a primordial position to the object’s response in the child’s symbolization process. To be discovered, the object has to “survive” the destructive activity and has to allow itself to be “used.” Winnicott refers here to three fundamental characteristics of object response: an absence of withdrawal, a lack of reprisals or retaliation, and a capacity to be manifestly creative and vital.

It is the object’s response to the destructivity, through the gap that it creates against the background of its primary adaptation to the subject’s needs and thus through a support that is introduced, that opens up the field of experience through which the complex process of symbolization will begin. The concept of the “good enough mother” is thus defined in its connection with the object’s pre-symbolizing function.

More recently, with reference to Winnicott, René Roussillon (1997) has sought to explore in more depth what he refers to as the object relationship that can allow representational activity and symbolization. He established symbolizing objects of the “malleable medium type” as a term by describing the qualitative characteristics of the relationship of primary attunement, and formulated a preliminary outline of the future attributes of the symbolization apparatus (hardness/malleability, indestructibility, tangibility, transformability, sensitivity, availability, reversibility, loyalty, and constancy).

Melanie Klein’s successors developed in new directions and reassessed her premises, including in the field of object relations and of projective identification as a primary mode of exchange. Esther Bick introduced the concept of adhesive identification and “psychic skin,” but it was principally Wilfred R. Bion who created new models for the relationship between two psyches. He defined the relationship between container and contained, and then analyzed this relationship using a complex mathematical system. During the maternal reverie, the alpha function psychically processes the beta elements, drives, and drive-derivatives that the child is unable to assimilate individually, in order to enable them to process these psychically, and then to introject this function itself. This is very much a theory of psychic transmission.

In France, Maurice Bouvet made Freud’s concept of the object relationship the main focus of his work, exploring it in more depth between 1948 and 1960 and developing it into a true concept. He and his students studied the object relationship in clinical practice (addressing hysteria, phobia, obsessional neurosis, and depersonalization) and went on to address the subject-subject relationship: the dual and reciprocal object relationship existing between ego-subjects. Addressing psychopathology in terms of the psychic object provides some ways of gaining a new perspective on the structural approach and produces a better understanding of difficult cases.

French psychoanalysts have preferred to address the successive description of the two psyches to account for the way in which the mother’s psyche contributes to the child’s psychic constitution. Denise Braunschweig and Michel Fain theorize “the lover’s censure” (1975), in which the mother’s experiences during pregnancy, her experience of childbirth, and the experiences relating to

the almost total erotism with the newborn give way retroactively to the fantasmatic elaboration of an incestuous erotic fulfillment in which the unconscious oedipal bedrock is evident. This conflict leads her to convey a censure to the child in a prelude to the fantasmatic life of the human being, in order to protect the child from the desire of and for the father, a two-fold desire that incorporates both the desire for her as a woman and the desire for the father’s penis in the child’s unconscious. The confused perception of these psychic realities then imposes on the mother the necessity of duping the child.

Jacques Lacan holds a distinctly opposing view, with his structural theory of the contribution of the symbolic register and of language as an organizer of the psychic; for him, there can be no discussion of drives that does not establish a “circuit of the drive” passing through the other; using a different term from that of the object, this big Other/little other demonstrates the theoretical shift from the intrapsychic to the intersychic. Following on from Lacan, Piera Aulagnier, with the “violence of interpretation” refers to the foundational violence that the “word-bearer” exerts over the infant and reintroduces temporality and a subject, the *I*, which is re-evaluated with reference to Lacan’s emphasis on the subject of the unconscious to the detriment of the ego. With his theory of the child’s “seduction” by the mother’s “enigmatic signifiers” as the origin of psychic life, Jean Laplanche does not restrict the object’s contribution to language but extends his theory to the object’s drives. In a different way, Didier Anzieu returns, through his metaphor of the “skin ego,” to a theory of a psychic formation based on the mother’s care and cathexis that is close to Esther Bick’s theory of “psychic skin.”

With his concept of “fantasmatic interactions,” Serge Lebovici, who took a particular interest in early mother-infant relations, provides an analytic version of the concept of interaction, which is too often influenced by objective reality. This is where Daniel Stern diverges from psychoanalysis: Although we may accept his concept of “emotional attunement,” his convictions regarding a neurophysiological evidence of perception lack the subtlety of Winnicott’s “created-found” and the importance of cathexis and hallucination for access to perception in Freudian theory. Let us further mention the originality of Christopher Bollas with his concept of the “transformational object”: the object is identified based on what the child feels is

modifying his experience of the self. Rather than being perceived as an object, the mother is experienced as a process of transformation.

For several authors, the need for the object to be inaccessible is a central focus of concern. For Jean Guillaumin, the object in psychoanalysis is postulated and targeted through the insistence of the drive but never actually given: We apprehend it as such only through our sense of that aspect of it which remains concealed to us. The rhythm of the mother's absence-presence and Winnicott's *holding* and *handling* can allow the experience of the hallucinatory satisfaction of desire theorized by Freud as an experience that establishes the drive orientation towards an object. However, the concept of the object corresponds to the experience of non-fulfillment because when it is found, attained, and mastered, it ceases to have any clinically observable psychic existence. This evident fact is irksome because it constitutes a paradox for logical thought; the nature of the total object can be described as something that necessarily includes a component of otherness that eludes the subject's control. This point is explored in more depth by Klein, who makes it the main focus of her essential reflections on the depressive position.

According to André Green, the concept of the object inevitably creates some philosophical difficulties, namely the impossibility of defining an object other than for a subject that constitutes it as an object and is constituted by it. This paradox is insurmountable. Subject and object are reciprocal terms: eliminating the object always means eliminating the libidinal subject and sexuality. According to Green, who therefore maintains the Freudian model, the object is primarily an object for the drive. However, there is an essential and constituent asymmetry between the pole of the subject (Green refers to the "ego-subject" because object and drive lead to the concept of the ego rather than of the subject) and the pole of the object in any consideration of the relationship with the other that introduces the third or "the other of the object." As concerns the link between the external object and the internal object: Whatever its indisputable reality (objective, objectal), the external object remains unknowable and it is only ever possible to work with its representatives. Psychoanalysis has nothing to say about this, unless it is by including a displacement in terms of function; if the object is described in these terms, it becomes possible to consider every process as an object.

André Green introduced the concept of the "objectalizing function": if the ego is characterized by certain appropriations of the object (incorporation, introjection, and beyond this, every form of internalization and identification), it transforms the status of the object with which it enters into a relationship, but above all it creates objects itself based on drive activity. What corresponds to the objectalizing function, an expression of the sexual drive, is its opposite and its negative: a disobjectalizing function, an expression of the death drive. Symbolization is placed here in the service of destructivity as the dramatization is transformed into an actualization. The disobjectalizing function operates to withdraw from the object the cathexes that are attached to it or even to move the object cathexes towards the narcissistic cathexes, narrowing the field of otherness.

In the United States, Otto Kernberg draws extensively on object-relations theory, which he regards as a supplement to ego-psychology and drive theory. He subscribes to Heinz Hartmann's theory that the ego defines the attitudes and intellectual processes that allow secondary-type mental activity, but there are many points of convergence between the views of this theorist, who has focused particularly on narcissistic disorders, and the European currents of psychoanalytic thought. For Kernberg, object relations are not a style of interaction with others but a mode of fantasmatic organization and a form of imaginary relationship with an object that is sustained to a greater or lesser degree by the perception of others. To the extent that every fantasmatic object relationship involves an imaginary relation between a self-representation and an object-representation, Kernberg argues that these object-relations become constituent of the personality and contribute to the person's individual development. Thus narcissism can no longer be considered simply as the return of the drive to the subject but as an internalization of a set of self-representations and representations of others that comprise intrapersonal relational systems. The general self-representation results from these partial representations; Kernberg takes up the description of the "grandiose self," a term introduced by Heinz Kohut (1974), which is concealed behind apparent signs of depression and inferiority feelings. However, whereas Kohut conceived the narcissistic organization of these patients as the result of a fixation at an archaic developmental stage of narcissism, Kernberg regards it as the result of a poor differentiation of the

psychic agencies, in which the grandiose self is a cluster of idealized and internalized object-relations, poorly differentiated self-representations, and pathological representations of the ego ideal. It thus certainly entails a combined pathology of the id, ego, and superego, that is mainly due to the excessive burden of the archaic aggressive drives. In this respect, Kernberg is closer to Melanie Klein than to Kohut; he has less confidence in the reparative value of psychotherapy than in the interpretation of archaic conflicts of ambivalence.

According to Jean Guillaumin (1997), a substantial, if not interminable, amount of work remains to be done on the question of the subject and the object. The anxiety surrounding experiencing oneself as a subject and being considered as a subject, which are preconditions for subject-object differentiation, is so intense in early experiences that it can only be checked by an auto-erotism of anxiety that can very naturally develop into a form of masochism, which thus becomes a matter for sharing and communicating with others on a minimal basis of a joint denial of difference. The sharing of the subject's anxiety with two or several individuals creates silences, attacks, and complicities in lack that seem to be the most authentic form of relationship between human beings (Angélo Hesnard).

NORA KURTS

*See also:* Abandonment; Addiction; Alienation; Allergic object relationship; Amae, concept of; Ambivalence; Anaclysis/anaclytic; Antilibidinal ego/internal saboteur; Asthma; Autism; Bizarre object; Cathexis; Childhood; Counter-identification; Counterphobic; Cruelty; Dead mother complex; Depersonalization; Depression; Depressive position; Drive/instinct; Ego; Envy; *Envy and Gratitude*; Externalization-internalization; Female sexuality; Femininity; Fetishism; Hatred; Idealization; Identification; Internal object; Libidinal stage; Lost object; Love-hate-knowledge (L/H/K links); Manic defenses; Mastery, instinct for; Maternal; Melancholia; "Mourning and Melancholia"; Narcissistic withdrawal; Object *a*; Object, change of/choice of; Object relations theory; Orality; Pain; Paranoid position; Paranoid-schizoid position; Partial drive; Passion; Pictogram; Primary object; Projection; Psychosexual development; Quasi-independence; Reparation; Rivalry; Self-hatred; Self-object; Splitting; Splitting of the object; Subject; Sublimation; Substitute/substitute-formation; Symbiosis, symbiotic relationship; Symbolization, process of; Transference relationship; Transitional object; Transitional object, space; Transitional phenomena; Turning around upon the subject's own self.

## Bibliography

- Bouvet, Maurice. (1967). *Œuvres psychanalytiques, t. I, La Relation d'objet: névrose obsessionnelle, dépersonnalisation*. Paris: Payot.
- Diatkine, René. (1989). Introduction à une discussion sur le concept d'objet. *Revue française de psychanalyse*, 53, 4, p. 1037–1043.
- Freud, Sigmund. (1915c). Instincts and their vicissitudes. *SE*, 14: 109–140.
- . (1923b). The ego and the id. *SE*, 19: 1–66.
- Green, André. (1995). La mort du moi et le destin des objets: Objet de la perversion, objet de la quiétude. In *Propédeutique: La métapsychologie revisitée* (pp. 279–284). Seyssel: Champ Vallon. (Original work published 1989)
- Guillaumin, Jean. (1997). D'objet, sujet devenir. *Revue française de psychanalyse*, 61 (2), 497–508.
- Kernberg, Otto. (1989). *Narcissistic personality disorder*. Philadelphia: W. B. Saunders.
- Klein, Melanie. (1967). *Essais de psychanalyse* (M. Derrida, Trans.). Paris: Payot.
- Roussillon, René. (1997). La fonction symbolisante de l'objet. *Revue française de psychanalyse*, 61 (2), 399–413.

## OBJECT A

Object *a* is the object that causes desire. Here, as is common in logic, a letter is used so as to avoid the confusion of meaning that could arise from the use of a more specific term.

At first, Jacques Lacan intended that *a* would designate the small other (*autre*)—that is, the fellow being—as an erotic object (Seminar 5, *Formations of the Unconscious*, 1957–58). Later, after having shown that lack is what makes the erotic object, Lacan used *a* to designate both what symbolizes this lack and also the lack itself.

In *Desire and Its Interpretation*, his seminar of 1958–59, Lacan used *a* to designate that part of the body given up in symbolic sacrifice. Its relationship of conjunction and disjunction with the barred subject is what constitutes the fantasy, as expressed in the formula,  $\$ \diamond a$ . It is disjoined from the subject, it is not the object that desire aims at, but rather it organizes the imaginary scenario of the fantasy which orders desire: *a* is thus the cause of desire (Seminar 10, *Anxiety*, 1962–63). Should object *a* become conjoined with the subject, this cannot be considered a recovery. It

also does not imply that the subject has some knowledge of the object. It is rather the transitory abolition of subject (aphanisis) in the face of the object, where the object is not the subject's complement, but its substitute.

Lacan believed that the original subject was sustained, prior to the loss of the object and the constitution of the fantasy, by what Donald W. Winnicott described as the transitional object. And referring to a later stage in the infant's life, he saw the reel in the *fort/da* game as a symbol of the part of the body that was being detached (and not as a symbol for the mother; to Lacan, separation was not about an infant separating from a mother, but rather about each of them separating from the object *a*).

Lacan differentiated four objects *a*, which he called "fragments of the body" (1975, p. 189): the breast, feces, the look, and the voice, each of which related to a bodily orifice and corresponded to a partial drive. These objects are not placed in developmental order. They are all designated by the same letter because they all have the same function, to symbolize castration. Object *a* is a partial object, but there is no corresponding whole object because *a*, insofar as it is lacking, creates an obstacle to any kind of totality.

The lost object could certainly be grasped in the imaginary register (as the breast from which the infant is separated or the feces that the infant rejects, for example), but that should not obscure the fact that Lacan used *a* to designate the real insofar as it is inexpressible by speech (thus the breast, as object *a*, is the inexpressible remainder of the oral demand). Object *a* is also outside of the phenomenal field, neither perceptible in the image of the body, nor in objects in the world.

This is why *a* is "the object that does not correspond to any idea," that is, "representation" (1975, p. 183). It is an object that can only be approached or delimited in logical or topological ways. Very early on, Lacan designated that which discourse made ungraspable as the "metonymic object," that is, the object that slides under the signifying chain. Later, he formalized *a* as the hole that hollows out the repetition of the demand (as in the model of the torus), like the disk that separates the cut from the signifier (as in the model of a cross-cap, a topological figure without edges that Lacan used to define the relations of the subject with the object as cause of desire). Then he defined *a* as the loss produced by the articulation of S1 and S2. This loss, which results from a subtraction of

*jouissance* by discourse, is what Lacan called "surplus *jouissance*," and it is homologous with Marx's "surplus value." The equivocal nature of this term, which in French can mean both "more enjoyment" and "no more enjoyment," indicates that something of this *jouissance* is regained in the functioning of the drive, which "gets around" (*fait le tour*) object *a*, in the sense that it both "circles" it and "evades" it. Starting in 1975, with the introduction of the Borromean knot, *a* became the point at which the three consistencies R, S, and I (Real, Symbolic, and Imaginary) are joined together, a kind of entry point for all *jouissance*.

Lacan considered his elaboration of object *a* as an extension of the discoveries of Karl Abraham and Winnicott and as opposed to object relations theory, which for him was confined to the register of the imaginary. This elaboration referred to Freud's distinction between narcissistic libido and object libido and refuses to consider the latter simply as a portion of the former that had somehow "overflowed," but instead wanted to show their structural difference. Lacan attempted to specify the mechanisms of object *a*'s diverse manifestations (anxiety is related to the emergence of *a*, and thus to the look in anxiety) and to establish clinical distinctions in relation to object *a* (the neurotic seeks to obtain object *a* by demand; the pervert makes object *a* the absolute condition of desire; and the psychotic keeps his objects *a* "in his pocket"). Lacan's work on object *a* has clinical implications because it directs the treatment toward a separation between the identification with the ego ideal and identification with the object *a*. This approach allows the analyst at the end of treatment to know the object of his or her fantasy.

VALENTIN NUSINOVICI

*See also:* Demand; Deprivation; Fantasy, formula of; Fort-Da; Four discourses; *Jouissance* (Lacan); Knot; L and R schemas; Metonymy; Object; Other, the; Seminar, Lacan's; Sexuation, formulas of; Signifier; Signifier/signified; Signifying chain; Subject of the drive; Subject's castration; Subject's desire; Topology; Want of being/lack of being.

### **Bibliography**

Lacan, Jacques. (1957–1958). *Le Séminaire-Livre V, Les Formations de l'Inconscient* (Formations of the unconscious), Paris: Seuil.

———. (1958–1959). *Le Séminaire-Livre VI, Le désir et son interprétation* (Desire and its interpretation), unpublished.



- . (1962–1963). *Le Séminaire-Livre X, L'angoisse* (Anxiety) Paris: Seuil, 2004.
- . (1964). *The seminar of Jacques Lacan, Book XI, The four fundamental concepts of psychoanalysis*. (Alan Sheridan, Ed.). New York: W. W. Norton, 1978.
- . (1974–1975). *Le Séminaire-Livre XXII, R.S.I.* (J.-A. Miller, Ed.) *Ornicar?*, 2–5.
- . (1975). La troisième, intervention de J. Lacan le 31 octobre 1974. *Lettres de l'École freudienne* 16, 178–203.

### Further Reading

- Akhtar, Salman. (1994). Object constancy and adult psychopathology. *International Journal of Psychoanalysis*, 75, 441–456.
- Meissner, William W. (1996). The self-as-object in psychoanalysis. *Psychoanalysis and Contemporary Thought*, 19, 425–460.
- Sandler, Joseph. (1990). The structure of internal objects and internal object relations. *Psychoanalytical Inquiry*, 10, 163–181.
- Smith, Henry. (2000). Countertransference, conflictual listening and the analytic object. *Journal of the American Psychoanalytic Association*, 48, 95–128.

## OBJECT, CHANGE OF/CHOICE OF

The expressions *change of object* or *choice of object* refer to the notion of a love-object. The theme of a change of object refers back to the earliest sources of object relations. In his “Three Essays on the Theory of Sexuality” (1905d) Sigmund Freud described object-choice as being “diphasic, that is, it occurs in two waves” (p. 200). The first wave occurs in the oedipal period and the second at puberty, when the definitive form that sexual life will take is determined. The sexual instinct that until then had been essentially autoerotic discovers the sexual object. The adolescent can choose a new object only after renouncing the objects of his or her childhood: “The finding of an object is in fact a refinding of it” (p. 222). Psychoanalytic authors have concurred in thinking that in both sexes, the primary object is the mother.

While, for Freud, the oedipal stage was lived out between two and five years of age, some post-Freudian authors consider an earlier Oedipus complex. Melanie Klein described a fantasy of both parents combined that is present very early in the infant’s psychic life. André Green also noted, in *Les Chaînes d’Éros* (1997);

The chains of Eros), that the father exists in the mother’s mind; she is the guardian of the father’s place, of the paternal function—“its metaphor,” in the words of Jacques Lacan. Denise Braunschweig and Michel Fain also introduced the father at an early stage, describing “censoring the lover in her” as a constituent element in the infant’s development. The introduction of the father into the primary bond with the infant very early on allows for early triangulation, the basis for the introduction of a third party into the relationship. But it is certain that from the outset, the mother’s relationship with her baby, whether a girl or a boy, entails a fantasmatic and interactive specificity owing to sexual difference: homosexual in the one case, heterosexual in the other. The fate of the primary object differs according to sex. The boy will return to it by displacement at the time of oedipal object-choice, while the girl must renounce it to proceed to a change of object.

This evolution is crucial in the course of development. For the girl, this is time when she libidinally invests her father and turns away from the maternal object. For the boy, this movement appears to be simpler. At puberty, under the influence of the superego, he turns away from the mother and can invest other objects. According to Freud, from the time of the phallic stage the girl develops an intense hatred for the mother (reflecting an ambivalent feeling of love-hate), which will foster a change in her object-choice. This explains the emergence of penis envy, which causes the girl to detach herself from her mother and take refuge in the oedipal situation. For her, Freud posited that object-change is of three orders: a change of love-object, a change of erotogenic zone (the clitoris is replaced by the vagina), and a change from an active to a passive position. During the preoedipal period, the little girl is both active and aggressive toward her mother, of whom she would like to have exclusive possession, and she feels her father to be a rival. At the time of the Oedipus complex, the girl turns from the mother toward the father, initially in a manner that is active, possessive, and sadistic. Love is directed toward the father and hatred toward the mother (through the castration complex). Catherine Parat theorized that these active sadistic impulses produce a masochistic shift in normal cases, which is accepted by the ego, and that this movement colors the development of femininity in a particular way. The taking up of the feminine, masochistic position entails a series of identifica-

tions with the mother, although without complete cessation of a degree of identification with the father. During and by means of the movement of object-change, the girl no longer lays claim to the penis; she has just traversed the pathway that leads from the desire to take the father's penis away from him, to the desire to receive a child from him. By means of feelings of tenderness and non-conflictual identifications with the mother, the girl can then (and this is an essential moment in her history) develop feelings of oedipal love for her father (and thus for men in general), an object different from herself. Through cathexis of her real gender, she has acquired the possibility of realizing her love in complementarity with the other. Heterosexuality is thus acquired, and the genital mode attained.

The integration of bisexuality is a fundamental element in heterosexual life. Feminine bisexuality causes some women to remain fixated on the mother, to make a homosexual object-choice, or to display alternating masculinity and femininity. Freud believed that in normal loving behavior, the currents of tenderness and sensuality come together. Tenderness is the older of these two currents. It comes from the first years of childhood and corresponds to the primary infantile object-choice. Then, with the advent of puberty, the powerful "sensual" current is added and will run up against the barrier of incest. This is when the tendency to find another, outside object with which to lead a real sexual life is manifested. Infantile object-choice paves the way for object-choice at puberty. In "On Narcissism: An Introduction" (1914c) Freud proposed that there are two fundamental types in the choice of the love-object: narcissistic object-choice and anaclitic object-choice. They are not necessarily opposed to one another, Freud thought, but may be subject to alternation or combination in each of us. In the first case, the choice of love-object relates to the subject himself; in the second case, anaclitic object-choice, the love-object is chosen based on the model of the parent figures. These two currents are present and complementary from the oedipal period.

Freud's writings on female sexuality have inspired heated controversies, and the feminine is a point on which he faltered. If the Oedipus complex is characteristic of both sexes, according to his theory a "sexual

monism" should exist until puberty in both sexes, the model of which would be the masculine one. The difficulty in Freud's work arises from anticipating a symmetry between what happens in boys and what happens in girls. Freud himself repeatedly underscored his uncertainty and the insufficient, trial-and-error nature of his inquiries into this "dark continent," as he called it, thus acknowledging the incompleteness of his explorations.

MAÏTÉ KLAHR AND CLAUDIE MILLOT

*See also:* Object.

### **Bibliography**

- Chasseguet-Smirgel, Janine, Luquet Parat, Catherine J., Grunberger, Béla, et al. (1964). *Female sexuality: New psychoanalytic views*. London: Virago.
- Freud, Sigmund (1905c). Three essays on the theory of sexuality. *SE*, 7: 123–243.
- . (1914d). On narcissism: An introduction. *SE*, 14: 67–102.
- Green, André. (2000). *The chains of Eros: The sexual in psychoanalysis* (Luke Thurston, Trans.). London: Rebus. (Original work published 1997)
- Parat, Catherine. (1964). Le changement d'objet. In *L'Affect partagé* (p. 36–47). Paris: Presses Universitaires de France.

---

**OBJECT-LIBIDO.** *See* Ego-libido/object-libido

---

## **OBJECT RELATIONS THEORY**

Psychoanalytic object relations theories may be defined as those that place the internalization, structuralization and clinical reactivation (in the transference and counter-transference) of the earliest dyadic object relations at the center of their motivational (structural, clinical, and genetic and developmental) formulations.

Internalization of object relations refers to the concept that, in all interactions of the infant and child with the significant parental figures, what the infant internalizes is not an image or representation of the other ("the object"), but the relationship between the self and the other, in the form of a self image or self representation interacting with an object image or

object representation. This internal structure replicates in the intrapsychic world both real and fantasized relationships with significant others.

Several major issues separate object relations theories, the most important of which is the extent to which the theory is perceived as harmonious with or in opposition to Freud's traditional drive theory: that is, whether object relations are seen as replacing drives as the motivational system for human behavior. From this perspective, Melanie Klein as well as Margaret Mahler and Edith Jacobson occupy one pole, in that they combine Freud's dual drive theory with an object relations theory approach. For Ronald Fairbairn and Harry S. Sullivan, on the other hand, object relations themselves replace Freud's drives as the major motivational system. Contemporary interpersonal psychoanalysis, as represented by Joanne R. Greenberg and Stephen Mitchell—based upon an integration of principally Fairbairnian and Sullivanian concepts—asserts the essential incompatibility between drive-based and object relations-based models of psychic motivational systems. Donald Winnicott, Hans Loewald, and Joseph Sandler (each for different reasons) maintain an intermediate posture; they perceive the affective frame of the infant-mother relationship as a crucial determinant in shaping the development of drives. While adhering to Freud's dual drive theory, Otto Kernberg considers drives supraordinate motivational systems, while affects are their constituent components.

A related controversy has to do with the origin and role of aggression as motivator of behavior. Those theoreticians who reject the idea of inborn drives (Sullivan), or equate libido with the search for object relations (Fairbairn), conceptualize aggression as secondary to the frustration of libidinal needs, particularly traumatic experiences in the early mother-infant dyad. Theoreticians who adhere to Freud's dual drive theory, in contrast, believe aggression is inborn and plays an important part in shaping early interactions: This group includes Klein in particular and to some extent Winnicott, and the ego psychology object relations theoreticians such as Kernberg.

Finally, contrast may be made between object relations theories and French approaches, both Lacanian and mainstream psychoanalysis. The latter has maintained close links with traditional psychoanalysis, including the British object relations theories, insofar as Lacan conceptualizes the unconscious as a natural

language and focuses on the cognitive aspects of unconscious development, he underemphasizes affect—a dominant element of object relations theories. At the same time, however, in postulating a very early oedipal structuralization of all infant-mother interactions, Lacan emphasizes archaic oedipal developments, which implicitly links his formulations with those of Klein. French mainstream analysis also focuses on archaic aspects of oedipal developments, but places a much more traditional emphasis on Freud's dual drive theory and on the affective nature of the early ego-id. As neither mainstream nor Lacanian psychoanalysis spells out specific structural consequences of dyadic internalized object relations, however, neither would fit the definition that frames the field of object relations theory as proposed in this essay.

All object relations theories focus heavily on the enactment of internalized object relations in the transference and on the analysis of counter-transference in the development of interpretive strategies. They are particularly concerned with severe psychopathologies, including those psychotic patients still approachable with psychoanalytic techniques, borderline conditions and severe narcissistic character pathology, and the perversions. Object relations theories explore primitive defensive operations and object relations both in cases of severe psychopathology and at points of severe regression with all patients.

The contemporary re-evaluation of Freud's dual drive theory that has occurred mostly in France is relevant to the relationship between object relations theory and drive theory. Perhaps particularly the work of Jean Laplanche and André Green has emphasized the central importance of unconscious destructive and self-destructive drive manifestations in the form of attacks on object relations, and the central role of unconscious erotization in the mother-infant relationship in libidinal development, all of which tends to link drive theory and object relations theory in intimate ways.

Another important development within psychoanalytic theory has been the growing emphasis on affects as primary motivators, and the centrality of the communicative functions of affects in early development, particularly the infant/mother relationship. This emphasis has linked affect theory and object relations theory quite closely, despite the persistent controversy between those who see affect, particularly peak affect states, as essential representatives of the drives, and

those who stress the psychophysiological nature of the affective response, and attempt to replace drive theory with an affect theory.

The basic units (self representation, object representation) of internalized object relations thus include the constituent affective components of the drives. One might say that the affect of sexual excitement is the central affect of libido in the same way as the affect of primitive hatred constitutes the central affect of the death drive. The id is conceptualized in this model as the sum total of repressed, desired, and feared primitive object relations. The gradual integration of successive layers of persecutory and idealized, prohibitive and demanding, internalized object relations forms part of the primitive superego, while internalized object relations activated in the service of defense consolidate as an integrated self structure within the ego, surrounded by integrated representations of significant others. In short, the Id or dynamic Unconscious, the Superego, and the Ego are constituted by different constellations of internalized object relations, so that the development of the drives and the development of the psychic apparatus—the tripartite structure—occur hand in hand.

Perhaps the most important practical implication of object relations theory is the conception of identification as a series of internalization processes ranging from earliest introjection to identification *per se*, to the development of complex identity formation. Each step includes the internalizing of both self and object representations and their affective interactions under the conditions of different developmental levels.

In the transference of healthier patients, with a well-consolidated ego identity, the diverse self representations are relatively stable in their coherent mutual linkage. This fosters the relatively consistent projection onto the analyst of the object representation aspect of the enacted object relationship. In contrast, patients with severe identity diffusion lack such linkage of self representations into an integrated self. They tend to alternate rapidly between projection of self and object representations in the transference, so that the analytic situation seems chaotic. Systematic interpretation of how the same internalized object relation is enacted again and again with rapid role reversals makes it possible to clarify the nature of the unconscious object relation, and the double splitting of (a) self representation from object representation

and (b) idealized from persecutory object relations. This process promotes integration of the split representations which characterize the object relations of severe psychopathology.

OTTO F. KERNBERG

*See also:* Analytical psychology; Basic fault; Benign/malignant regression; Bouvet, Maurice Charles Marie Germain; Dead mother complex; Early interactions; Ego (ego psychology); Ego psychology; Eroticism, anal; False self; Feminism and psychoanalysis; Genital love; Great Britain; Object; Oedipus complex; Self (true/false); Subject's castration; Unconscious fantasy.

### **Bibliography**

- Fairbairn, W. Ronald D. (1954). *An object-relations theory of the personality*. New York: Basic Books.
- Greenberg, Stephen, and Mitchell, Jay. (1983). *Object relations in psychoanalytic theory*. Cambridge, MA: Harvard University Press.
- Kernberg, Otto F. (1992). *Aggression in personality disorders and perversion*. New Haven, CT: Yale University Press.
- Krause, Rainer. (1998). *Allgemeine psychoanalytische Krankheitslehre*. Stuttgart: Kohlhammer.
- Sandler, Joseph, and Sandler, Anne-Marie. (1998). *Internal objects revisited*. London: Karnac Books.
- Sullivan, Harry S. (1953). *Interpersonal theory of psychiatry*. New York: W. W. Norton.

---

**OBRAS COMPLETAS.** *See* Biblioteca Nueva de Madrid (Freud, S., *Obras Completas*)

---

## **OBSESSION**

The term *obsession* refers to images, ideas, or words that force themselves into the subject's consciousness against their will, and which momentarily deprive them of the ability to think and sometimes even to act. The term is derived from the Latin *obsidere*, which means "to sit before," "to lay siege to," and figuratively "to control an audience." From this is derived the noun *obsidio*, which means "detention," or "captivity," and figuratively "a pressing danger."

Classical psychiatrists had described the experience of a person whose consciousness was besieged by an

intrusive thought and who, although lucid and in possession of his faculties, was incapable of stopping it. Philippe Pinel (mania without delusion), Jean-Étienne Esquirol (affective monomania), and Jules Baillarger (madness accompanied by conscious awareness) all distinguished this pathology from mental alienation in the strict sense. But it was Bénédict-Augustin Morel (emotional delusion) and Jean-Pierre Falret (the madness of doubt and the delusion of touch) who described a clinical picture that was closest to what would later be referred to as obsessional neurosis.

It was Sigmund Freud, however, in his description of obsessional neurosis in “Heredity and Aetiology of the Neuroses” (1896a), who considered obsession to be a symptom that is part of a larger clinical picture, a symptom that serves as a compromise and has an economic function. “Obsessive ideas ... are nothing but reproaches addressed by the subject to himself because of anticipated sexual pleasure, but these reproaches are disfigured by an unconscious psychic process of transformation and substitution.”

For Freud the notion of *Zwang* (compulsion) assumed a much broader and more fundamental meaning than that which he gave it in the clinical picture of obsessional neurosis. It reflects what is most radical in the drive: “In the mental unconscious, we can recognize the supremacy of a repetition compulsion arising from libidinal emotions that are most likely dependent on the most intimate nature of drives that are sufficiently powerful to place themselves above the pleasure principle, lending certain aspects of psychic life their demoniacal character” (1919h).

In his article on the case of the “Rat Man” (1909d) Freud writes, “The definition I gave in 1896 of compulsive ideas, namely that they are ‘reproaches that have been repressed but now return transformed, always related to a sexual act from childhood that brought pleasure when carried out,’ seems to me today to be arguable in formal terms. ... In fact it is more correct to speak of ‘compulsive thinking’ and to emphasize the fact that compulsive structures may be equivalent to the most diverse psychic actions. These may be defined as wishes, temptations, impulses, reflections, doubts, commands and prohibitions.”

Obsessions must be distinguished from phobias. A *phobia* is the fear of an object in the outside world whose absence or avoidance is sufficient, in principle, to avoid anxiety, while an *obsession* involves a

mental representation that the subject cannot escape. Although the distinction had little meaning for Pierre Janet when he described “psychasthenia,” it was essential for Freud. Phobias are associated with the qualities of objects, whereas obsessions are concerned with the characteristics of mental representations. Obsessions must also be distinguished from *idées fixes* and *prevalent ideas*: “The latter are integrated in the subject’s personality and are not recognized as unhealthy. A claimant can be constantly preoccupied with the idea of an injustice suffered; he suffers from it, tries to obtain satisfaction by any means, but never thinks that the object of his preoccupations is absurd or without grounds” (Guiraud, 1956). As for the impulsive act, it lacks the hesitation and internal struggle typical of obsession, which, even resolved, always entails a period of uneasiness and indecision.

There would be little point in making a list of obsessions by type. They can be religious, metaphysical or moral; they might concern purity or physical protection, or protection against external dangers; or follow questions of precision and completeness, order and symmetry, or the flow of time (Green, 1965).

It would almost be possible to retrace the evolution of psychiatry from the classical period to the present-day by following the status of obsessions within the clinical groupings provided by various authors. We have seen how Freud, by giving obsession its status as a symptom, something that is both a compromise and has an economic function, enabled dynamic psychiatry to become thoroughly modern. The description of obsessional neurosis served as a model for all psychoanalytic theory. This is why Freud, throughout his work, constantly returned to the economic, topographical, and metapsychological problems presented by this concept.

Innovations in the United States (DSM III and IV—*Diagnostic and Statistical Manual of Mental Disorders*) have expanded the framework of clinical concepts and brought about the near disappearance of the science of psychopathology. As a result, new groups of symptoms have been introduced, based on a statistical approach, and new entities created, such as the compulsive obsessional disturbances. These revisions have expanded the clinical spectrum by including somatic obsessions (hypochondria, dysmorphophobia), physical obsessions (eating disorders like anorexia and bulimia), sexual obsessions (paraphilia), and pathological jealousy. In this way we have come full circle, back to a

prepsychoanalytic era, back to the origins of classical psychiatry itself.

MARC HAYAT

*See also:* Obsessional neurosis.

### **Bibliography**

Freud, Sigmund. (1896a). Heredity and the aetiology of the neuroses. *SE*, 3: 141–156.

———. (1909d). Notes upon a case of obsessional neurosis. *SE*, 10: 151–318.

———. (1919h). The “uncanny.” *SE*, 17: 217–256.

Green, André. (1965). Obsessions et psychonévrose obsessionnelle. In *Encyclopédie médico-chirurgicale, Psychiatrie*. Paris: E.M.-C., fasc. 37–370–A–10, p. 1–10, B–10, p. 1–5, C–10, p. 1–6, D–10, p. 1–14.

Hantouche, Élie. (1995). Troubles obsessionnels compulsives. In *Encyclopédie médico-chirurgicale, Psychiatrie*. Paris: E.M.-C., fasc. 37–370–A–10, p. 1–14.

———. (1997). Obsession. *Les Objets de la psychiatrie* (p. 389–390). Paris: L’Esprit du temps.

Lantéri-Laura Georges, and Del Pistoia, Luciano. (1984). Névrose obsessionnelle. In *Encyclopédie médico-chirurgicale, Psychiatrie*. Paris: E.M.-C., fasc. 37–370–A–10, p. 1–20.

### **Further Reading**

Esman, Aaron. (2001). Obsessive-compulsive disorder: Current views. *Psychoanalytical Inquiry*, 21, 145–156.

Freud, Anna. (1966). Obsessional neurosis: A summary of Congress views. *International Journal of Psychoanalysis*, 47, 116–122.

Gabbard, Glen. (2001). Psychoanalytic approaches to treatment of obsessive-compulsive disorder. *Psychoanalytical Inquiry*, 21, 208–221.

## **OBSESSIONAL NEUROSIS**

The term *obsessional neurosis* (or *compulsive neurosis*) denotes a condition in which the patient’s mind is intruded upon (against his or her will) by images, ideas, or words. The patient’s consciousness nevertheless remains lucid and his or her power to reason remains intact. These uncontrollable obsessions are experienced as morbid inasmuch as they temporarily deprive the individual of freedom of thought and action. Sometimes the defenses can eliminate the anxiety and the symptoms, but at the price of displacing

characteristics of primitive obsession (uncontrollability, compulsions) onto the defense mechanisms.

Sigmund Freud’s view of obsessional neurosis appeared as early as 1894. In “The Neuro-Psychoses of Defence” (1894a) he broke with the conceptions of classical psychiatry and stipulated that the cause of obsessional neurosis lies in the existence of an intrapsychic conflict of sexual origin that mobilizes and blocks all flows of energy. He thus opposed the classical theory of degeneration and the idea of innate weakness of the ego that Pierre Janet used as the basis for his description of psychasthenia. Freud proposed a traumatic etiology for obsessional neurosis. An early sexual event occurs before puberty; however, in contrast to what happens in hysteria, this event is a source of pleasure to the child. The individual experiences strong feelings of guilt and is overcome by self-reproach. These feelings are repressed and then replaced by a primary system of symptoms and traits: scrupulousness, shame, mistrust of self. The success of these defenses allows the individual to go through an apparently healthy period. But eventually these defenses are exhausted and there is a return of the repressed memories with the outbreak of the illness and its attendant symptoms.

In “The Disposition to Obsessional Neurosis: A Contribution to the Problem of Choice of Neurosis” (1913i), Freud defended the idea that the choice of this neurosis is linked to developmental inhibitions, and he stressed the role of fixation and regression to the anal-sadistic stage. He suggested “the possibility that a chronological outstripping of libidinal development by ego development should be included in the disposition to obsessional neurosis. A precocity of this kind would necessitate the choice of an object under the influence of the ego-instincts, at a time when the sexual instincts had not yet assumed their final shape, and a fixation at the stage of the pregenital sexual organization would thus be left” (p. 325). Thus, in the object relation, hate will precede love and “obsessional neurotics have to develop a supermorality in order to protect their object-love from the hostility lurking behind it” (p. 325). This opposition between love and hate for the object was underscored by Freud in the case of the “Rat Man,” related in “Notes upon a Case of Obsessional Neurosis” (1909d). He saw it as the source of the doubt, compulsions, and ambivalence that are characteristic of obsessional functioning.

In “Inhibitions, Symptoms and Anxiety,” Freud described the two main defense mechanisms in obsessional neurosis that replace repression: undoing what has been done and isolation. The first of these, undoing (*Ungeschehenmachen*), means making something that has already happened “unhappen” by means of a symbolic motor action; it is also found in magical practices, folk customs, and religious rituals. The second, isolation, involves the motor sphere and consists in the fact that after an unpleasurable event there is a pause during which nothing further can happen, no perception is possible, and no action can take place. Motor isolation functions to guarantee a break in the connection of thoughts.

In the same way that the obsessional patient enacts the taboo against touching (because he fears that contact with the object will force him to face his unbound ambivalence between love and hate), the isolation of an impression or an activity, by means of a break in the chain of thoughts, symbolically indicates that he does not want to allow thoughts relating to it to “contaminate” other thoughts. This mechanism is present in normal people in their everyday mental activities involving concentration.

The fundamental rule of free association involves asking the ego to give up this defense. The patient suffering from obsessional neurosis finds it particularly difficult to follow this rule. This is why, paradoxically, psychoanalysis is both the most indicated treatment for these patients and at the same time the most difficult to implement.

Like Freud, the psychoanalysts who came after him always placed the accent on the obsessional structure rather than on symptoms. This poses problems of terminology. The term *obsessional neurosis* is not the exact equivalent of the German *Zwangsneurose*: *Zwang* refers not just to compulsive thought or obsessions (*Zwangsvorstellungen*), but also to compulsive acts (*Zwangshandlungen*) and compulsive affects (*Zwangsaffecte*). Certain French authors therefore prefer to use the term *névrose de contrainte*, and some American authors prefer the term *compulsive neurosis*. *Obsessional functioning* is the preferred term for the group of processes and defense mechanisms that characterize obsessional neurosis, but which are also present, to a lesser degree, in other patients, in the form of obsessive personality traits or a system of defenses put up as an alternative to a costlier mode of psychic functioning, psychotic functioning.

In this regard, let us note that because organized obsessional neuroses are sometimes extremely debilitating, the categorization of this pathology has been questioned and it has been compared with the psychoses. Several factors present in the former are lacking in the latter: self-recrimination by the ego, adherence to insistent preoccupations, and the deployment of elaborate defenses. In the obsessional patient, affective isolation allows the ego to cut itself off from desire, whereas in psychosis the ego is cut off from reality.

MARC HAYAT

*See also:* Activity/passivity; Ambivalence; Anality; Analsadistic stage; “A.Z.”; Castration complex; Compromise formation; Compulsion; Death and psychoanalysis; Demand; Displacement; Doubt; Eroticism, anal; “From the History of an Infantile Neurosis” (Wolf Man); *Future of an Illusion, The*; “Heredity and the Etiology of the Neuroses”; Id; “Inhibitions, Symptoms and Anxiety”; Instinctual impulse; Intellectualization; Isolation (defense mechanism); Neurosis; Obsession; Omnipotence, infantile; Omnipotence of thought; Phobia of committing impulsive acts; Psychic structure; Neuro-psychosis of defense; Quota of affect; Rationalization; Reaction-formation; Religion and psychoanalysis; “Repression”; Rite and ritual; Secondary revision; Self-punishment; Stage; Symptom-formation; Taboo; Thought; Tics; Turning around upon the subject’s own self.

### Bibliography

- Freud, Sigmund. (1913i). The disposition to obsessional neurosis: A contribution to the problem of choice of neurosis. *SE*, 12: 311–326.
- Green, André. (1965). Obsessions et psychonévrose obsessionnelle. In *Encyclopédie médico-chirurgicale*, Volume: *Psychiatrie*. Paris: E.M.-C., fasc. 37-370-A-10: 1–10; B-10: 1–5; C-10: 1–6; D-10: 1–14.
- Leclair, Serge. (1996). *Écrits pour la psychanalyse*. Paris: Le Seuil-Arcanes.
- Mannoni, Octave. (1985). Obsession et névrose obsessionnelle. *Encyclopaedia Universalis*, 13, 308–310.

## OCCULTISM

Occultism is the belief in secret doctrines and practices that are recognized neither by science nor religion and require some form of initiation. Related, but distinct, is telepathy, mental communication at a distance with

the dead or the living. Such beliefs appeared in nineteenth-century Europe with the weakening of Christian churches, which had traditionally fought these phenomena, and as a form of resistance to rationalism, which claimed to be able to explain everything by means of logical reasoning. Occultism and telepathy are also related to an interest in mystery and the mysterious: Sir Arthur Conan Doyle, the creator of Sherlock Holmes, devoted much his later life to the study of occultism, and a number of successful authors have taken an interest in paranormal phenomena.

Psychology and psychiatry in the late nineteenth century were strongly influenced by spiritualism and magnetism. Belief in a “celestial fluid” was not wholly unrelated to the growing use of an invisible energy (electricity), or a new device for communicating at a distance, known as the telephone. Freud referred specifically to this last invention to characterize the relationship between conscious and unconscious, between doctor and patient (“Recommendations to Physicians Practising Psycho-Analysis,” 1912e). The word *telepathy* was created in 1882 by the English psychologist Frederick Myers (1843–1901), who was the first British author to discuss Freud’s work.

Parapsychology was referred to by Freud during his conversations and correspondence with several of his followers, primarily Theodor Reik and Sándor Ferenczi. With his daughter Anna and Ferenczi, he performed thought transmission and table-turning experiments. In his articles “Psychoanalysis and Telepathy” (1941d [1921]) and “Dreams and Telepathy” (1922a), he clarified his position with respect to paranormal phenomena as being a combination of “repugnance and ambivalence.”

Freud’s thoughts on occultism and telepathy involve an element of ambiguity as well as tactical maneuvering. Freud, the founder of psychoanalysis, was unable to ignore the support the fragile new movement received from parapsychology, while also having to confront the criticisms of rationalist science. However, based on the advice of Ernest Jones and Max Eitingon, he did not wish to compromise the scientific nature of psychoanalysis with irrational theories. Faced with the “black sea of occultism,” Freud maintained a prudent sense of reserve, although this did not hamper his considerable interest in techniques of communication between minds, which presented analogies with transference.

ODON VALLET

See also: *New Introductory Lectures on Psycho-Analysis*; Telepathy.

### Bibliography

- Freud, Sigmund. (1922a). Dreams and telepathy. *SE*, 18: 195–220.
- . (1933a) New introductory lectures on psychoanalysis. *SE*, 22: 1–182.
- . (1941d [1921]). Psycho-analysis and telepathy. *SE*, 18: 173–193.
- Freud, Sigmund, and Ferenczi, Sándor. (1992). *The Correspondence of Sigmund Freud and Sándor Ferenczi* (Peter T. Hoffer, Trans.). Cambridge, MA: Belknap Press of Harvard University Press.

---

## OCEANIC FEELING

After reading *The Future of an Illusion* (1927c), in a letter dated December 5, 1927, Romain Rolland wrote to Freud: “By religious feeling, what I mean—altogether independently of any dogma, any Credo, any organization of the Church, any Holy Scripture, any hope for personal salvation, etc.—the simple and direct fact of a feeling of ‘the eternal’ (which may very well not be eternal, but simply without perceptible limits, and as if oceanic). This feeling is in truth subjective in nature. It is a contact.” (Vermorel and Vermorel, 1993, p. 304)

The notion of an *oceanic feeling* derives on the one hand from the writings of Baruch Spinoza, who criticized religion but, with his “third degree of knowledge,” retained “the intellectual love of God,” and on the other hand from Rolland’s studies on Indian mysticism: *The Life of Ramakrishna* (1929/1931) and *The Life of Vivekananda and the Universal Gospel* (1930/1947). He sent these works to Freud, providing him with a name for a concept hitherto latent in his thinking.

In the first chapter of *Civilization and Its Discontents* (1930a [1929]) Freud located the oceanic feeling within the primitive ego—more precisely, within primary narcissism and the ego ideal—which is later reduced to a “shrunk residue” (p. 68) under the influence of reality. Freud compared that ego to the vestiges of ancient Rome lying beneath the constructions of later centuries; and Rolland, perhaps unsurprisingly for a man whose writings are so immersed in the universal Mother that the role of the father in the Oedipus complex is circumvented, sensed that Freud’s



reference to the Eternal City, to Rome and the Romans, betokened a primal maternal transference.

Upon receiving Rolland's letter, Freud experienced a mixture of excitement ("your letter has left me without any rest") and, it would seem, paralyzing shock, for it took him two years to write a response to Rolland's letter and another two years to send it—which might be interpreted as a transference reliving of the trauma of the premature death of his baby brother Julius when he himself was two years old. There was an unconscious complicity between Freud and Rolland, who had also been wounded by grief in childhood: Rolland's *Journey Within* (1942/1947), begun immediately after his visit to Freud, started with this event and was mirrored by Freud's "A Disturbance of Memory on the Acropolis (An Open Letter to Romain Rolland on the Occasion of His Seventieth Birthday)," addressed to Rolland in 1936, which was the ultimate self-analysis of his relations with his father and also with the "dead mother."

Freud later acknowledged that he had not done justice to religion and its "historical truth." In response to Rolland, "one of the twelve men upon whom rests the destiny of the world," he gave free rein to his fantasy of being the Moses of psychoanalysis; in retrospect, his trajectory can be considered as an approach, within the individual unconscious, to the sacred, where he had taken refuge after the "death of God."

HENRI VERMOREL AND MADELEINE VERMOREL

See also: *Civilization and its Discontents*; *Future of an Illusion*, *The*; Religion and psychoanalysis; Rolland, Romain Edme Paul-Émile.

### Bibliography

- Freud, Sigmund. (1927c). The future of an illusion. *SE*, 21: 1–56.
- . (1930a [1929]). Civilization and its discontents. *SE*, 21: 57–145.
- . (1936a). A disturbance of memory on the Acropolis (An open letter to Romain Rolland on the occasion of his seventieth birthday). *SE*, 22: 239–248.
- . (1939a [1934–38]). Moses and monotheism: Three essays. *SE*, 23: 1–137.
- . (1931). *The Life of Ramakrishna* (E. F. Malcolm-Smith, Trans.). Mayavati, Almora, Himalayas: Advaita Ashrama. (Original work published 1929)

———. (1947). *The Life of Vivekananda and the Universal Gospel* (E. F. Malcolm-Smith, Trans.). Calcutta: Advaita Ashrama. (Original work published 1930)

———. (1947). *Journey within* (Elsie Pell, Trans.). New York: Philosophical Library. (Original work published 1942)

Vermorel, Henri, and Vermorel, Madeleine, eds. (1993). *Sigmund Freud et Rolland Romain. Correspondance 1923–1936*. Paris: Presses Universitaires de France.

## ODIER, CHARLES (1886–1954)

Charles Odier, a Swiss psychoanalyst, was born in Geneva in 1886 and died in Lausanne in 1954.

Born into a family of shopkeepers and musicians, Odier completed his secondary education in Geneva before going on to study medicine, and training as a neurologist and psychiatrist in Geneva, Vienna, and Paris. In 1920 he set up in Geneva as a general practitioner. He devoted himself increasingly to psychoanalysis until 1929, when he left for Paris.

As early as 1914 Odier took an interest in Freud's ideas, and in 1923 he went into analysis with Van Ophuijsen in the Netherlands before going on to work for one semester in the Berlin polyclinic with Franz Alexander (to which he returned for a second period in 1927). He joined the Swiss Psychoanalytic Society (founded in 1919) and in 1920 he was among the founding members of the short-lived Geneva Psychoanalytic Society with Édouard Claparède as its president.

Between 1920 and 1929 Odier worked on developing Freud's ideas, not only in French-speaking Switzerland but also in Paris where, along with Raymond de Saussure, he was one of the founding members of the Paris Psychoanalytic Society. We also find him among the initiators of the Conference for French-Speaking Psychoanalysts, which met for the first time in Geneva in 1926. The following year, in 1927, he played an active role in the creation of the *Revue française de psychanalyse*, being a member of the directing committee from 1927 until 1938. In 1929 Odier settled in Paris where he practiced psychoanalysis until 1939. He returned to Switzerland when war broke out and worked in Lausanne as a psychoanalyst until his death in 1954.

His "Contribution à l'étude du Surmoi et du phénomène moral" (Contribution to the study of the superego and the moral phenomenon) was a congress

report that was destined to present Freud's recently-elaborated (1927) notions of the ego, superego, and id to French-speaking psychoanalysts. In his essay *Les Deux Sources consciente et inconsciente de la vie morale* (The twin sources, conscious and unconscious, of moral life; 1943) he sought to shed light on the connections between conscious moral judgments and the unconscious relations between the ego and the super-ego. *L'Angoisse et la pensée magique* (Anxiety and magical thought; 1948) and *L'Homme esclave de son infériorité* (Man as slave of his own inferiority; 1950) are an effort to conceptualize the ego's problems of insecurity and anxiety both in terms of psychoanalysis and Jean Piaget's psychogenetics. He published some sixty papers, more than forty of them being devoted to psychoanalysis.

JEAN-MICHEL QUINODOZ

*See also:* Congrès des psychanalystes de langue française des pays romans; France; *Revue française de psychanalyse*; Société psychanalytique de Genève; Société psychanalytique de Paris et Institut de psychanalyse de Paris; Switzerland (French-speaking); Switzerland (German-speaking).

### Bibliography

Flammer, J.-A. (1995). *Le psychanalyste: Ch. Odier*. In C. Müller (Ed.), *Portraits de psychiatres romands* (pp. 103–157). Lausanne, France: Payot.

Odier, Charles. (1927). Contribution à l'étude du Surmoi et du phénomène moral. *Revue française de psychanalyse*, 1 (1), 4–75.

———. (1943). *Les Deux Sources consciente et inconsciente de la vie morale*. Neuchâtel, France: La Baconnière.

———. (1950). *L'Homme esclave de son infériorité*. Neuchâtel, France: Delachaux & Niestlé.

Roch, Marcel. (1967). L'œuvre de Charles Odier, médecin et psychanalyste. *Bulletin de la Société suisse de psychanalyse*, 6, 5–7.

## OEDIPUS COMPLEX

The term *Oedipus complex* designates a network embracing the wishes and hostile impulses of which the mother and the father are the objects, along with the defenses that are set up to counter these feelings. Freud called this complex “the nucleus of the neuroses,” and, beyond that, it may be considered the central structure in the functioning of the human mind.

This skeletal definition needs refining in a number of ways:

- Although very direct expressions of the Oedipus complex can be observed in young children, for the most part it manifests itself through unconscious formations identifiable only through their transposition onto other objects and their impact on other kinds of conflict.
- The term itself suggests the complexity of this network; most modern-day authors assign it a structuring role in the development of the psyche, of which it will later become an essential functional feature.
- It is important to distinguish between two *aspects* of the Oedipus complex, depending on whether the little boy's desire is directed at his mother and his hostility at his father (the *positive* version), or vice versa (the *negative* or *inverted* complex).
- In both of these instances, the conflict is between wish and prohibition, a fact which signals that the cultural context of the establishment of the conflict in the child must not be overlooked.
- By extension, it should be borne in mind that, although the objects in question in any society founded on the triangular or nuclear family are the father and mother, this may not be so in other cultures.
- Lastly, because the Oedipus complex concerns not only the difference between generations but also that between the sexes, a distinction must perforce be drawn between the case of the girl and that of the boy.

The term *Oedipus complex* itself did not appear in Freud's published work until his paper “A Special Type of Object-Choice Made by Men” (1910h, p. 171). At that time, with some reluctance, he borrowed the word *complex* from Carl Jung. Freud's reference to the myth of Oedipus, however, originates much earlier. In a letter dated October 15, 1897, to his friend Wilhelm Fliess, he wrote: “I have found, in my own case too, falling in love with the mother and jealousy of the father, and I now regard it as a universal event of early childhood. . . . If that is so, we can understand the riveting power of *Oedipus Rex*” (1954 [1887–1902]). Indeed the notion is to be found in *Studies on Hysteria*, where Freud, in quest of the etiology of hysteria, stressed the traumatic role of sexual

*seductions*, experienced by the child and for which the father was responsible (1895d).

The notion took on growing significance for Freud over the next few years, as witnessed by the following remarks from *The Interpretation of Dreams*: “It is as though—to put it bluntly—a sexual preference were making itself felt at an early age: as though boys regarded their fathers and girls their mothers as rivals in love, whose elimination could not fail to be to their advantage” (Freud, 1900a, p. 256), and “it is the fate of all of us, perhaps, to direct our first sexual impulse towards our mother and our first hatred and our first murderous wish against our father. Our dreams convince us that this is so. King Oedipus, who slew his father Laius and married his mother Jocasta, merely shows us the fulfillment of our own childhood wishes” (p. 262). The theme was also central to Freud’s analysis of “Dora” (1905e [1901]). It is noteworthy, however, that the Oedipus complex made no explicit appearance in *Three Essays on the Theory of Sexuality* (1905d), though Freud took an important step forward in that work by fully acknowledging for the first time the idea of a childhood sexuality prior to puberty. The implications of this were very clear in the case of “Little Hans,” published four years later, where Freud focused his explanation of the horse phobia of this “lively little boy” on oedipal impulses: desire for the mother founded on a very active infantile sexuality, along with fear of the father’s retribution (1909b). In another case history published in the same year, that of the “Rat Man” (1909d), the role of the Oedipus complex, though evident, was veiled. By contrast, in his narrative of the “Wolf Man” case, effectively completed by the fall of 1914, Freud assigned the complex a major role, correlating it with the theme of the primal scene (the perception, whether real or fantasized, of sexual intercourse between the parents) (1918b [1914]).

Throughout this whole period, therefore, the Oedipus complex was pivotal to Freud’s clinical thinking. One problem continued to bother him, however. He considered that the complex was universal, a defining characteristic of the human race. But how was this universality to be explained? He offered one possible answer in *Totem and Taboo* (1912–13a), where he hypothesized as follows: In very ancient times humans were organized in *primal hordes*, each dominated by a strong, despotic male who monopolized the women and banned their access to the young men under the

ultimate threat of castration. But a day came when the sons rose up, killed the father and thus gained access to the women. Thenceforward, however, guilt for this primal crime dogged them. Passed down from generation to generation, the conflict between wish and prohibition, still dominated by guilt regarding the murder of the father, is reborn in each individual: Such is the origin of the Oedipus complex. This mythical story (which aroused opposition even among prehistorians) is typical of Freud’s tendency to revisit history and model the past of the individual on the past of humanity as a whole: Psychogenesis was based on what he called *phylogenesis*. Two years after *Totem and Taboo*, Freud carried this line of inquiry even further in *A Phylogenetic Fantasy: Overview of the Transference Neuroses*, a text so speculative that he himself refrained from publishing it.

As omnipresent as the notion is in his works, it is striking that, aside from these two contributions concerned with the conjectured history of humanity, Freud never devoted a theoretical text to the specific issue of the Oedipus complex; in the great metapsychological papers of 1915 the oedipal theme is evoked only indirectly. There are, however, two papers, from 1923 and 1924 respectively, which clarify Freud’s thinking on the issue in two major respects.

In “The Infantile Genital Organization” (1923e), Freud described for the first time what would thereafter be considered a major turning-point in mental development, namely a complete reorganization, occurring roughly between the ages of three and five, centered on the primacy of the penis as erotogenic zone and, with respect to object-relations, on the oedipal drama. In this way Freud rounded out his developmental theory, which identified a series of *stages* or *phases*, also referred to as *organizations*), each characterized by the primacy of a particular erotogenic zone and by a specific object-relational mode. Thus, the oral phase was followed by the anal, the phallic (or oedipal), and then, after a “period of latency,” adult genital organization. The phallic phase constituted the high point of the oedipal scenario: During this time sexual desires directed toward the parent of the opposite sex, as well as castration anxiety aroused by the child’s fear of retribution from the rival parent, were at their most intense. Later this conflict would wane, as repression did its work (in this case welcome work), and the child would enter latency. Puberty and the intense psychic work it initiated would reactivate the

earlier conflict in new guises, but after this stormy episode equilibrium would be achieved thanks to the onset of adult genital organization and the changes of object it made possible: the shift of desire to a woman other than the mother, or a man other than the father.

May we then conclude that the Oedipus complex fades away? Freud's paper titled, precisely, "The Dissolution of the Oedipus Complex" might be thought to suggest as much. In this text, Freud spoke of the complex being destroyed, or collapsing "because the time has come for its disintegration, just as the milk-teeth fall out when the permanent ones begin to grow" (1924d, p. 173). It is impossible to believe, however, that Freud intended to abandon his major thesis according to which the Oedipus complex was the very framework of the human psyche. What disappears, in fact, is oedipal conflict in its infantile form—not the form of organization that results from it.

There are two points that need emphasizing here. In the first place, oedipal conflict in its most acute phase constitutes an essential motor of the play of identifications through which the individual person is constructed; the little boy, after wishing to *be* his father, and thus replace him in his mother's bed, eventually wishes instead to be *like* his father with respect to other women. Secondly, the reference to the boy cannot be allowed to obscure the problem of the Oedipus complex in the girl. This issue constituted a major theoretical stumbling block for Freud, and it has been a continual source of difficulty for Freud's successors.

To begin with, Freud simply described the Oedipus complex in boys and added that, *mutatis mutandis*, the same applied to girls. The problem lay in the *mutatis mutandis*. As long as only the "positive" aspect of the complex was considered, it was enough to say that the little girl directed her incestuous desires toward her father, from whom she wished to obtain a child; indeed, this represented the realization in fantasy of the penis envy that, according to Freud, she harbored since finding out that, unlike boys, she had no penis (1925j). Later on, after the "resolution" of her Oedipus complex, she would obtain that child from a man other than her father.

But this account appeared too simple, even to Freud himself, once it became clear that the Oedipus complex had to be viewed in its *complete* form, composed of both positive and negative aspects. How did the boy and the girl, respectively, enter the oedipal

crisis that confronts these two aspects, and how did they emerge from it? And how, in each case, did the play of identifications become established?

Freud's own answer to this question focused on castration anxiety. He asserted that, for the girl as for the boy, there was at first only one sexual organ, the male one. According to this *infantile sexual theory*, everyone had a penis, even if it was not obvious; it sufficed to say, with "Little Hans," that it was "quite small," but "it'll get bigger all right" (Freud, 1909b, p. 11). The child's discovery of the anatomical difference between the sexes was greeted at first by incredulity. In the boy, this was soon replaced by anxiety: if the little girl did not have one, it must be that she *no longer* had one; he believed that she used to have one, like everyone else, but had been deprived of it. In other words, the little boy understood girls to be, in effect, boys castrated as punishment for their masturbation and incestuous wishes. Thenceforward, castration anxiety, in the case of the boy, would be the chief motor of renunciation of such wishes and behavior, and the factor that would get him out of the acute oedipal crisis of the phallic phase. In contrast, Freud described castration anxiety in the case of the girl as stemming from a castration that had already taken place, and for which she sought reparation from her father, was what caused her to "enter" the oedipal crisis. She would emerge from it, like the boy, by means of a change of object, by directing her desire toward a man other than her father, just as the boy directed his toward a woman other than his mother.

The term *change of object* needs clarifying, for it might seem ambiguous. The child's first object, for both the boy and the girl, is said to be the mother; this was Freud's view, and all psychoanalytic thinking since Freud has confirmed it. The boy effects change in a fairly simple way, shifting his desire to another person of the same sex as his mother; the girl, for her part, must transfer her desire onto someone of the opposite sex. Things remain straightforward, however, only as long as we focus exclusively on the positive complex; things become much more complicated as soon as we consider the complete form, and this theoretical step has sparked a good deal of controversy. Indeed, debate surrounding the theory of the Oedipus complex has remained intense in post-Freudian psychoanalytic discourse.

- a) Freud's original *phallic monism* aroused vigorous protest during his own lifetime, notably

among women psychoanalysts such as Ruth Mack Brunswick, Helene Deutsch, Karen Horney, and Melanie Klein. It is important to bear in mind that Freud's ideas on the primacy of the phallus, penis envy, and castration do not apply to biological or sociological realities but rather to an imaginary register inscribed in culture as well as in the unconscious of each individual. Beyond that, problems of female sexuality, and of femininity itself, remain important areas for psychoanalytic investigation.

- b) As mentioned above, Freud saw the phallic, or oedipal phase as preceded in turn by two other major modes of organization, dominated by the oral and anal erotogenic zones respectively, each having its specific type of object-relationship. Since Freud's time, ever greater attention has been paid to these so-called *pregenital* phases, such as the earliest object-relationships, the *primary narcissism* in which the subject is forged, and lastly to autoerotism, the basis of this whole process of development. Their deep theoretical divergences notwithstanding, Anna Freud and Melanie Klein, the founders of child analysis, have played an essential part in this avenue of research; other contributors include pediatricians, notably Donald W. Winnicott, and, more typically, child psychiatrists such as Margaret Mahler, Donald Meltzer, Frances Tustin, Serge Lebovici, and René Diatkine. The field in which most of this work was done was childhood psychopathology, though it has been rounded out by studies of the earliest mother-child relationship conducted within psychoanalysis (Serge Lebovici) or on its fringes (Daniel N. Stern).
- c) Beyond the consideration of the origins of the Oedipus complex, this whole line of advance has given rise to the suggestion that the complex itself might be primal in character. Thus Melanie Klein, in certain of her writings, went so far as to say that, like the object, the oedipal structure was present from birth or even earlier; this thesis has been widely rejected, however, by many psychoanalysts. More acceptably, Claude Le Guen (1974) has described a *primal Oedipus complex* said to embody an initial triangular situation involving the nascent subject, the mother, and a third party who provokes *eight-month anxiety*,

characterized by René Spitz as a response to the perception of a stranger whose presence suffices to reveal the absence of the mother and cause the child to recreate her intrapsychically to mitigate this loss (Spitz and Cobliner, p. 155). Similarly, André Green (1990) has evoked the relations between the self, the object, and the *Other's object*.

- d) The claim that the Oedipus complex is universal has occasioned lively polemic. Some authors, such as Géza Róheim, set out to demonstrate the correctness of Freud's view by mustering the ethnographical evidence. This approach was contested by anthropologists and sociologists who emphasized the diversity of family and social structures from one culture to another, and based on those grounds argued that such a complex could only exist within a modern Western society—or even only in the *fin-de-siècle* Vienna of Freud's day. A whole *culturalist* current (Bronislaw Malinowski, Ruth Benedict, Margaret Mead, and others) sought a middle way. Many years after Freud's time, these controversies seem somewhat dated. Claude Lévi-Strauss (1949/1969) crystallized an important idea in this connection by asserting that, whatever the differences in human social and familial forms, the prohibition against incest was both fundamental and universal.
- e) Finally, it has long been evident that non-oedipal forms of mental organization, or those just lightly marked by the Oedipus complex, are widely found; this truly vast field, extending from perverse structures to autism and infantile and adult psychoses, has seen very significant developments over the last two or three decades.

In conclusion, let it be said that the Oedipus complex and its correlate, the castration complex, are at the very heart of psychoanalysis. These ideas underwent a long maturation within Freud's work, and the theoretical tendencies that have developed since Freud have brought out the great complexity that attends them. The fact remains that in clinical practice these two notions are indispensable to the analyst and invoked on a daily basis; from a theoretical point of view, even if a synthesis is still elusive (there are as many attempts as there are major authors), there is a good measure of agreement on a few essential points.

The assumption that the Oedipus complex is universal remains axiomatic to the architecture of the theory; after all, it is felt to be the basis of the specificity of the human race. It is generally acknowledged, further, that a primary conflict between desire and its prohibition first arises in relation to two parental figures who incarnate its future operation. To which it should be added, in accordance with the contribution of Melanie Klein, that each of these two figures, just like the subject, present two aspects, as “good” and “bad” objects of love and hate. This is the context in which the complete Oedipus complex, and the play of identifications that springs from it, need to be apprehended.

ROGER PERRON

See also: “From the History of an Infantile Neurosis (“Wolf Man”); Amnesia; Infantile amnesia; Analysis of a Phobia in a Five-year-old Boy (Little Hans).

### **Bibliography**

- Freud, Sigmund. (1900a). The interpretation of dreams. *SE*, 4–5: 1–625.
- . (1905d). Three essays on the theory of sexuality. *SE*, 7: 123–243.
- . (1905e [1901]). Fragment of an analysis of a case of hysteria. *SE*, 7: 1–122.
- . (1909b). Analysis of a phobia in a five-year-old boy. *SE*, 10: 1–149.
- . (1909d). Notes upon a case of obsessional neurosis. *SE*, 10: 151–318.
- . (1910h). A special type of choice of object made by men (Contributions to the psychology of love I). *SE*, 11: 163–175.
- . (1912–13a). Totem and taboo. *SE*, 13: 1–161.
- . (1918b [1914]). From the history of an infantile neurosis. *SE*, 17: 1–122.
- . (1923e). The infantile genital organization (An interpolation into the theory of sexuality). *SE*, 19: 141–145.
- . (1924d). The dissolution of the Oedipus complex. *SE*, 19: 171–179.
- . (1925j). Some psychical consequences of the anatomical distinction between the sexes. *SE*, 19: 241–258.
- . (1954). *The origins of psycho-analysis: Letters to Wilhelm Fliess, drafts and notes, 1887–1902* (Marie Bonaparte, Anna Freud, and Ernst Kris, Eds.). New York: Basic Books.

———. (1987; 1985a [1915]). *A phylogenetic fantasy: Overview of the transference neuroses* (Ilse Grubrich-Simitis, Ed.; Alex Hoffer and Peter T. Hoffer, Trans.). Cambridge, MA: Harvard University Press.

Freud, Sigmund and Breuer, Josef. (1895d [1893–95]). Studies on hysteria. *SE*, 2: 1–310.

Green, André. (1990b). *Le complexe de castration*. “Que sais-je?” Paris: Presses Universitaires de France.

Le Guen, Claude. (1974). *L’Oedipe originaire*. Paris: Payot.

Lévi-Strauss, Claude. (1969). *The elementary structures of kinship* (James Harle Bell, John Richard von Sturmer and Rodney Needham, Trans.). Boston: Beacon Press. (Original work published 1949)

Perron, Roger, and Perron-Borelli, Michèle. (1994). *Le complexe d’Oedipe*. “Que sais-je?” Paris: Presses Universitaires de France.

Spitz, René A., with Cobliner, W. Godfrey. (1965). *The first year of life: A psychoanalytic study of normal and deviant development of object relations*. New York: International Universities Press.

### **Further Reading**

Greenberg, Jay. (1991). *Oedipus and beyond: A clinical theory*. Cambridge, MA: Harvard University Press.

Loewald, Hans W. (1979). The waning of the oedipus complex. *Journal of the American Psychoanalytical Association*, 27, 751–776.

———. (1985). Oedipus complex and development of self. *Psychoanalytic Quarterly*, 54, 435–443.

Ogden, Thomas H. (1989). The threshold of the male Oedipus Complex. *Bulletin of the Menninger Clinic*, 53, 394–413.

Simon, Bennett. (1991). Is the oedipus complex still the cornerstone of psychoanalysis?. *Journal of the American Psychoanalytic Association*, 39, 641–668.

Steiner, John. (1996). Revenge and resentment in the “Oedipus situation.” *International Journal of Psychoanalysis*, 77, 433–444.

---

## **OEDIPUS COMPLEX, EARLY**

Underlying the Oedipus complex as Freud described it, there is an earlier layer of more primitive relationships with the oedipal couple. These precede the classical Oedipus complex that arises in the third year of life and subsides with the development of the superego. This notion first appears in a Melanie Klein publication (1927a and b).

In describing the Oedipus complex in a letter to Wilhelm Fliess dated October 15, 1897, Freud (1985c) founded psychoanalysis upon a theory of fantasies. The core of childhood development is the fantasies about the oedipal couple. He sought to verify these theories with evidence from children (1909a). A number of people produced children's fantasies that confirmed the Oedipus complex, among them Sándor Ferenczi (1913/1927).

Klein developed a rigorous technique for working with children, through which she demonstrated that disturbing oedipal fantasies intrude into all the activities of childhood. She found areas of development in the infant that were too distant to reach with adult analysis. The Oedipus complex was active, in some form, from a period much earlier than the third year of life. The evidence was of two kinds: Firstly, the analysis of symptoms which had started in the first year of life indicated fantasies, anxieties, and defenses that operated then, when the symptoms started. Secondly, much of the fantasy life involved pregenital impulses suggesting the presence of the three-person constellation of exclusion, rivalry, and murder, right back to the oral phase. She also concluded that the violence of the Oedipus complex can be seen to arouse guilt in children, and therefore posited the presence of a super-ego at the earliest stages of the Oedipus complex. That finding reversed the theory of the development of the super-ego out of the Oedipus complex (Klein, 1928, 1933).

It was not only children's play, but the developmental task of learning that could be obstructed, according to Klein (1930, 1931). The development of the primal scene into the terrifying images of the early Oedipus complex could lead to severe distortions of intellectual development.

These early fantasies had a remarkably different character from those of the later "mature" Oedipus complex. In these early phases the oedipal objects were experienced in primitive form, archaically "good" or "bad," and engaged in an immense variety of forms of intercourse between themselves. So different was this conception of the oedipal couple that Klein coined the term "combined parent figure" for it. In 1935 Melanie Klein described the depressive position, which arises from a major developmental step. At that point good and bad versions of the object can be recognized for the first time to be the same figure in reality (1935,

1940). Much of the distortion of the oedipal couple at the early stage is connected with the combining of the good and bad objects. The capacity to enter the depressive position marks the transition from the early Oedipus complex to the mature stage and results in an increasing respect for the reality of external objects. And with the emergence into the depressive position, feelings of protectiveness and repair gather, as the determining characteristics of the mature Oedipus complex (1945).

When Klein described the paranoid-schizoid position (1946) her interest in the Oedipus complex fell away, and the world of primitive defense mechanisms at the earliest moments in life absorbed the energy of Kleinian research. It was not until the 1980s that Kleinians returned to a serious study of the Oedipus complex (Britton, et al., 1989).

The Oedipus complex has come to be seen less in terms of innate impulses of love and hate. Instead the primal scene, which the oedipal parents inhabit, is a stage upon which enquiry, learning, and creativity are founded. The child has the opportunity to attain the third position, the observer of (and enquirer into) parental intercourse. Achieving this position emotionally is the primitive foundation of thought, knowledge, and intellectual life.

Otto Fenichel (1931) postulated a connected notion, that of "precursors of the Oedipus complex."

Early fantasies are regarded by many analysts as immature and unformed attempts at creating mental representations of the external reality, and not necessarily as having a central role in development. These early experiences are claimed by some to be mere precursors of the mature Oedipus complex; present, but essentially inactive components.

ROBERT D. HINSHELWOOD

*See also:* Archaic mother; Combined parent figure; Unconscious fantasy.

### **Bibliography**

- Britton, Ron, Feldman, Michael, and O'Shaughnessy, Edna. (1989). *The Oedipus complex today*. London: Karnac Books.
- Fenichel, Otto. (1931). The pre-genital antecedents of the Oedipus complex. *International Journal of Psycho-Analysis*, 12, 138–170.

- Ferenczi Sándor. (1927). Ein kleiner Hahnemann. In his *Bausteine zur Psychoanalyse*: Vol. 2, *Praxis* (pp. 185–195). Leipzig: Internationaler psychoanalytischer Verlag. (Originally published 1913)
- Freud, Sigmund. (1909a). Analysis of a phobia in a five-year-old boy. *SE*, 10: 3–147.
- . (1985c [1887-1904]). *The complete letters of Sigmund Freud to Wilhelm Fliess 1887-1904* (Jeffrey Mousaieff Masson, Ed. and Trans.). Cambridge, MA, and London: Belknap/Harvard University Press.
- Klein, Melanie. (1927a). Criminal tendencies in normal children. *British Journal of Medical Psychology*, 7, p. 177–192. Repr. 1975 in: *The Writings of Melanie Klein*, t. I, London: Hogarth, p. 170–186.
- . (1927b). Symposium on child analysis. *International Journal of Psycho-Analysis*, 8, p. 339–370. Repr. 1975 in: *The Writings of Melanie Klein*, t. I, London: Hogarth, p. 139–169.
- . (1928). Early stages of the Oedipus conflict. *International Journal of Psycho-Analysis*, 9, p. 167–180. Repr. 1975 in: *The Writings of Melanie Klein*, t. I, London: Hogarth, p. 186–198.
- . (1975). The Oedipus complex in the light of early anxieties. In *The Writings of Melanie Klein* (Vol. 1). London: Hogarth. (Reprinted from *International Journal of Psycho-Analysis*, 26, (1945), 11–33.)

## OMNIPOTENCE OF THOUGHTS

The belief that ideas are all-powerful is inherent in animistic thought and belief systems but also common in obsessional neurosis, where the same kind of magical thinking occurs as a symptom. It consists in the belief that one can transform or influence the external world through one's thoughts alone.

In *Totem and Taboo* (1912–13a), Freud emphasized that he owed the expression “omnipotence of thoughts” to “a highly intelligent man who suffered from obsessional ideas,” (p. 85)—in fact, the “Rat Man” (1909d). That it was a question of something symptomatic in nature and not part of a system of thought was clear from the fact that the patient acted on the basis of superstitious ideas that ran counter to his own convictions. At the same time, according to Freud, omnipotence of thoughts underscores a general trait characteristic of every neurosis. “Neurotics . . . are only affected by what is thought with intensity and pictured with emotion, whereas agreement with external reality is a matter of no importance” (1912–13a, p. 86).

Omnipotence relates, in fact, only to thoughts that express or are derived from a repressed wish. Unconscious aims create or modify reality. As such, omnipotent thinking suggests the way an infant may employ hallucination to overcome a perceived lack of some object of gratification. In the adult, it is the attempt to ward off unconscious hostile wishes that leads to animistic thinking and obsessional neurosis.

The concept of omnipotence of thoughts can not be dissociated from narcissistic thinking or narcissism more generally conceived. In “On Narcissism: An Introduction” (1914c), Freud employed the notion of omnipotence of thoughts and desires—in infants, primitive peoples, and schizophrenics—as a means to establish the concept of narcissism theretofore evoked only in *Totem and Taboo*. That libidinal energy is invested first of all in the ego and, later on, partly in objects suggests how the outside world can be subjected to the power of thoughts. This kind of narcissistic investment will subsequently be found in adult self-esteem, leading to repression of all that fails to conform to the ego ideal; similarly, however, “every remnant of the primitive feeling of omnipotence which . . . experience has confirmed, helps to increase . . . self-regard” (1914c, section 2), which is the very expression of the ego's grandiosity.

To the extent that it originates in primary narcissism, omnipotence of thoughts is a notion susceptible to various elaborations that touch on the earliest modalities of an infant's representation of, and relation to, the external world. Sándor Ferenczi (1916) discussed the development of the sense of reality and emphasized that the child remains attached to omnipotence even after acknowledging that reality must be taken into account. In her discussion of the sense of reality in a four-year-old, Melanie Klein (1923) also underscored the child's belief in omnipotence of thoughts. D. W. Winnicott (1970) showed how maternal care lavished on infants promotes the feeling of omnipotence necessary to evoke the object, who though already present is recognized only through the illusion of creating it.

It is difficult to restrict or impose limits on the concept of omnipotence of thoughts inasmuch as, whether located in magical practices and animistic thinking or in neurotic symptoms, it is coextensive with the boundary-less character of primary narcissism.

SOPHIE DE MIJOLLA-MELLOR



*See also:* Animistic thought; Fascination; Fort-Da; Infantile omnipotence; Magical thinking; Mythology and Psychoanalysis; Primitive horde; Real trauma; Taboo; “Uncanny, The”; Thought; Wish, hallucinatory satisfaction of a.

### **Bibliography**

- Ferenczi, Sándor. (1916). Stages in the development of the sense of reality. In *Sex in psycho-analysis*. Boston: Richard C. Badger.
- Freud, Sigmund. (1912–13a). Totem and taboo. *SE*, 13: 1–161.
- . (1914c). On narcissism: An introduction. *SE*, 14: 67–102.
- Klein, Melanie. (1923). The development of a child. *International Journal of Psycho-Analysis*, 4, 419–474.
- Winnicott, Donald W. (1970). The mother-infant experience of mutuality. In E. Anthony, T. Benedek (Eds.). *Parent-hood: Its psychology and psychopathology*. Boston: Little, Brown.

## **“ON DREAMS”**

Freud’s major work, *The Interpretation of Dreams* (*Die Traumdeutung*, 1900a), was published in November of 1899, and he was disappointed that the book initially met with little success. His friend Wilhelm Fliess suggested that he publish a more easily-accessible, abridged version, but Freud resisted the idea, as he was already working on *The Psychopathology of Everyday Life* (1901b). However, he soon got to work on the project, which he considered to be strictly utilitarian drudgery. The essay appeared in 1901.

By its very nature, the book is a summary that adds nothing to *The Interpretation of Dreams*, but in thirteen short, untitled chapters, Freud did lay out the essentials of his theory of dreams:

- The analysis of dreams, the “royal road” to the elucidation of unconscious processes, aims at extracting the latent meaning from the manifest text of the dream (the dream narrative).
- Every dream represents the fulfillment of a wish.
- The dream work proceeds in two stages, the first being that of primary processes (condensations, displacements, representation by images) and the second being that of secondary processes that set up the “façade” of the dream; the satisfaction that is aimed at in a dream is thus possible because of the disguise of its latent content.

- Dreams involve symbolic processes that must be deciphered on a case-by-case basis; but there are also “typical dreams” that are in some sense universal, and the meaning of these can be taken as immediately apparent.

In this short work, Freud added the narrative and analysis of six new dreams, of which the best known is that of the “company at table d’hôte” (pp. 636–640). He also completed the analysis of the dream of “Goethe’s attack on Herr M.” (pp. 662–63), in which he revealed his aggressive feelings toward Wilhelm Fliess, whose friendship with Freud was soon to come to an end.

ROGER PERRON

*See also:* Dream.

### **Source Citation**

Freud, Sigmund. (1901a). Über den Traum. In L. Löwenfeld, and H. Kurella (Eds.) *Grenzfragen des Nerven- und Seelenlebens* (pp. 307–344). Wiesbaden, Germany: J.-F. Bergmann; *GW*, 2–3: 643–700; On dreams. *SE*, 5: 629–685.

### **Bibliography**

Freud, Sigmund. (1900a). The interpretation of dreams. Part I, *SE*, 4: 1–338; Part II, *SE*, 5: 339–625.

## **“ON NARCISSISM: AN INTRODUCTION”**

In a letter written to Karl Abraham on September 21, 1913, while he was vacationing in Rome, Sigmund Freud announced he had begun “the sketch of an article on narcissism” (Freud and Abraham, 1965a [1907–26, p. 148]). The term was borrowed from a German psychiatrist, Paul Näcke, and the notion that the self “is a frequent placement of the libido (narcissism)” had already been circulating for almost three years in psychoanalytic discussions (Nunberg and Federn, session of 18 May 1910, p. 541) and in writings by analysts such as Isidar Sadger. At an evening gathering of the Vienna Psychoanalytic Society on October 12, 1910, Freud commented, “A prolonged remaining at the transitory stage of narcissism definitely predisposes to homosexuality and to dementia (Bleuler’s ‘autism’)” (Nunberg and Federn, p. 13). Freud had evoked this notion himself in *Leonardo da Vinci and a Memory of His Childhood* (1910c) and in his thinking on homosexuality, and in 1911 Otto

Rank had published "A Contribution to Narcissism" in the *Jahrbuch*.

However, Freud's essay had, and would continue to have, repercussions on a far greater scale. Carl Gustav Jung's criticisms of the libido theory, and his remark that it failed to account for dementia praecox, led Freud, in this period of rupture with his former "heir apparent," to sketch out a theoretical text that he would return to several months later, and would complete shortly after he finished the more polemical "On the History of the Psycho-Analytic Movement" (1914). "I am short because again engaged in writing. Narcissism has to be finished," he wrote to Ernest Jones on February 25, 1914 (Freud and Jones, p. 265). On March 16, he wrote to Abraham: "Tomorrow I am sending you the 'Narcissism,' which was a difficult birth and bears all the marks of it. Of course I do not like it particularly, but it is the best I can do at the moment. It is still very much in need of retouching" (Freud and Abraham, 1965a [1907–26], p. 167); and, on March 25: "Since finishing the 'Narcissism' I have not been having a good time. A great deal of headache, intestinal trouble, and already a new idea for work, which is an added difficulty for the summer" (p. 168). On April 6, in response to Abraham's congratulations, he wrote: "Your acceptance of my 'Narcissism' affected me deeply and binds us still more closely together. I have a strong feeling of its serious inadequacy. I shall incorporate the comment you would like on the by-passing of sublimation in the Zürich therapy" (pp. 170–71).

"On Narcissism" is divided into three parts. In the first, Freud seeks to show that the libido theory is applicable to "paraphrenia" if one is willing to accept that "the libido that has been withdrawn from the external world has been directed to the ego" (p. 75). Thus, it is possible to distinguish between "ego-libido" and "object-libido," and "the more the one is employed, the more the other becomes depleted" (p. 76). At which point, "in the total absence of any theory of the instincts" (p. 78; such a theory would be elaborated only six years later, in *Beyond the Pleasure Principle*), a debate began over the hypothetical distinction between "sexual instincts" and "ego instincts."

In the second part of Freud's paper, the study of narcissism is approached by way of the study of "organic disease, hypochondria, and the erotic life of the sexes" (p. 82). The last of these gives Freud a

chance to discuss the conditions under which object-choice occurs. The "anaclitic" type is already known ("the woman who feeds [the individual]," "the man who protects him" [p. 90]), but to this must be added loving "according to the narcissistic type: (a) what he himself is (i.e. himself), (b) what he himself was, (c) what he himself would like to be, (d) someone who was once part of himself" (p. 90). Object-love of the anaclitic type is said to be "characteristic of the male" (p. 88), in contrast to women, whose narcissism, like that of children (onto whom parents project their own narcissism), cats, beasts of prey, humorists, or master criminals, acts as a powerful attraction.

The third and last section proposes a theoretical improvement that prefigures the changes of the second topography of 1923. By attributing repression to "the self-respect of the ego" (*Selbstachtung*) (p. 93), Freud defined an "ideal" against which each individual measures his or her actual ego. "This ideal ego [*Idealich*] is now the target of the self-love which was enjoyed in childhood by the actual ego" (p. 94). Narcissism is displaced onto it or onto the object chosen to represent it, a process that is different from the desexualization of the object in sublimation. A psychic agency must perform the task of "seeing that narcissistic satisfaction from the ego ideal is ensured and which, with this end in view, constantly watches the actual ego and measures it by that ideal" (p. 95)—an observing agency that Freud linked to moral "conscience" (p. 95) and in which the earliest administration of the superego may be discerned.

Numerous clinical considerations on delusions of grandeur, the paranoiac's feeling of being observed, passionate love, narcissism in homosexuality, or group psychology have illustrated or further enriched the major new lines of theoretical inquiry introduced in this short paper, which has become one of the touchstones of psychoanalytic theory and an essential moment in its development.

ALAIN DE MIJOLLA

See also: Narcissism; Rank, Otto.

### Source Citation

Freud, Sigmund. (1914). Zur Einführung des Narzissmus. *Jahrbuch für Psychoanalyse*, VI, 1–24; On narcissism: An introduction. *SE*, 14: 73–103.

### **Bibliography**

- Freud, Sigmund. (1910c). Leonardo da Vinci and a memory of his childhood. *SE*, 11: 57–137.
- Freud, Sigmund, and Abraham, Karl. (1965a [1907–26]). *A psycho-analytic dialogue: The letters of Sigmund Freud and Karl Abraham, 1907–1926* (Hilda C. Abraham and Ernst L. Freud, Eds.; Bernard Marsh and Hilda C. Abraham, Trans.). New York: Basic Books.
- Freud, Sigmund, and Jones, Ernest. (1993 [1908–39]). *The complete correspondence of Sigmund Freud and Ernest Jones, 1908–1939* (R. A. Paskauskas, Ed.). London: Belknap Press of Harvard University Press.
- Nunberg, Hermann, and Federn, Ernst (Eds.). (1962–1975). *Minutes of the Vienna Psychoanalytic Society*. New York: International Universities Press.

---

## **“ON THE HISTORY OF THE PSYCHOANALYTIC MOVEMENT”**

On January 12, 1914, Sigmund Freud wrote to Karl Abraham: “I am writing the history of the psychoanalytic movement. The text will be very energetic and direct.” On February 15 he wrote, “I have just finished, no more than an hour ago, the manuscript for ‘On the History of the Psychoanalytic Movement.’” The text turned out to be a polemic he had “worked on in a rage” (January 12 letter to Sándor Ferenczi) and which Freud intended to use against Jung and the Zurich group. On several occasions he uses the term ‘bomb,’ reflecting the jittery state of Europe’s nerves and the popular myth of the mad bomber anarchist on the eve of World War I. Moreover, Jung had given up his position as president of the International Psychoanalytical Association (IPA) on April 20 and the Zurich Group withdrew from the IPA in July, after Freud’s text appeared in print.

Under the epigraph “*Fluctuat nec mergitur*,” the text is divided into three chapters. In the first Freud explains the subjective nature of his contribution to the history of the psychoanalytic movement: “For psychoanalysis is my creation; for ten years I was the only one occupied with it. . . . Even today, when I am no longer the only psychoanalyst, I feel myself justified in assuming that none can know better than myself what psychoanalysis is.” According to the method he again advocated in 1923, he began by relating the history of his discovery, especially that of the sexual etiology associated with infantile sexuality, an emphasis that was intended to counteract Alfred Adler and Carl Gustav Jung’s rejection of this aspect of his theory.

Chapter 2 describes the birth and development of the psychoanalytic movement but, to defend himself from accusations of intolerance, Freud emphasizes that “the self-reliance of intellectual workers, their early independence of their teacher, is always gratifying from a psychological point of view.” He exposed the differences that existed between “experiments with association” and “free association,” for a number of commentators, especially in France, confused the two. He also attempted, although in vain, to stifle interest in the theory of “complexes” by showing that it did not have “the value attributed to it by people outside psychoanalysis . . . it cannot be inserted naturally and logically into the existing group of psychoanalytic theories.”

The geographic map of the movement’s conquests followed: Northern Europe, America, India. But, “among European countries France has hitherto shown itself the least disposed to welcome psychoanalysis.” Freud also provides a fairly complete picture of the relationship between psychoanalysis and the other branches of knowledge without, however, repeating the arguments he made in “Claims of Psycho-Analysis to Scientific Interest” (1913j), which had appeared the previous year.

The third chapter is the most directly political and polemic. Based on the advice of his first readers, Freud softened some of his comments, but he is addressing the crowd of followers who are still hesitating between Freud, Adler, Stekel, and, especially, Jung. The future of the movement depends on their decision. After reviewing the foundation of the IPA in 1910, Freud provides the background to the dissension that followed, specifying that while he is constrained to “make use of analysis,” he will reduce its use to the minimum since “analysis is not suited, however, for polemical use; it presupposes the consent of the person who is being analyzed and a situation in which there is a superior and a subordinate.”

Adler is the first to be discussed, for his theory constitutes a “system” and, although it makes a contribution to the psychology of the ego, it ignores unconscious motivations, especially sexuality. The “will to power” and “masculine protest” weaken repressed tendencies or the fears aroused by the threat of castration. But if Adler’s claims are based on a theory of instincts, including aggressivity, the same cannot be said of Jung. Jung’s ideas are confused, and dominated by desexualization and moralizing, which

have denatured the discoveries of psychoanalysis to create an ethical-religious system. “The sexual libido was replaced by an abstract idea,” the “Oedipus complex has been given a ‘symbolic’ sense,” the only recognized conflict being that of the “life task” and “psychic inertia,” and so on. “The truth is that these people have picked out a few cultural overtones from the symphony of life and have once more failed to hear the mighty and primordial melody of the instincts.” This reflects the disastrous consequences of these transformations on a form of therapeutic practice that no longer recognizes either the past or the transference. And Freud concludes, “that the new teaching which aims at replacing psycho-analysis signifies an abandonment of analysis and a secession from it.”

On February 8, 1914, Freud announced to Ernest Jones, “I have done with the first rogue today and hope I may finish the other next Sunday.” On February 11 he wrote to Ferenczi, “I am writing very assiduously on the history of the  $\Psi$ -a movement, and I hope to have worked on Jung, and with that have finished it by Sunday.”

Jones drew from this the conclusion that Freud should never be allowed to abandon “the fields of pure science in the positive sense. My desire has been to create around you a circle of men who will take care of the opposition while you continue your work; the perspective of an ideal situation of this type appears very promising” (letter of May 25, 1914). This was to be the birth of the secret committee.

ALAIN DE MIJOLLA

See also: Anna O., case of; Complex; *Jahrbuch der Psychoanalyse*; Jung, Carl Gustav.

### Source Citation

Freud, Sigmund. (1914d) Zur Geschichte der psychoanalytischen Bewegung. *Jahrbuch für Psychoanalyse*, 6, 207–260; *G.W.*, X, 43–113; *On the History of the Psychoanalytic Movement*, SE, 14: 7–66.

## “ON THE ORIGIN OF THE ‘INFLUENCING MACHINE’ IN SCHIZOPHRENIA”

Viktor Tausk completed his medical studies in 1919 and went on to work as a psychiatrist with an interest in the psychoses. After three consultations with Tausk, a Miss Natalija A. consented to describe for him the

*influencing machine* which she felt was being operated in an obscure fashion by a rejected suitor of hers who had previously sought to influence her, to make her agree to marry him. Though in Tausk’s view this case was unique, the machine described was analogous, if atypically, to a number of such machines alluded to but not interpreted in the psychiatric manuals. In “On the Origin of the ‘Influencing Machine’ in Schizophrenia”, Tausk developed several psychoanalytical hypotheses.

Influencing machines were of a “mystical nature,” described by patients at once in would-be technical terms and allusively with respect to their persecutory effects, namely images, thoughts, feelings, motor phenomena, sensations, and various bodily manifestations. Such a machine would make its appearance late in the evolution of schizophrenia, arguably as the unstable product of feelings of estrangement, of influence, of inner change, or of transformation that for their part tended to emerge early on, and in a most striking way. A machine would be constructed in an attempt at identification with the persecutor and projection into the outside world. After the fashion of the complicated machines in dreams, the influencing machine was an outwardly projected representation of a patient’s genital organs conflated with his or her own body. Tausk noted how attempts would be made to eliminate parts of the body (sexual organs, arms, and so on), and how the head (in the case of Natalija A.) might be replaced by a “lid” (as of a coffin).

Interpreting this description in the light of another symptom of schizophrenia, the loss of ego boundaries, Tausk set forth hypotheses concerning the combined and conflictual development of narcissism and ego-formation. Whereas an “innate” narcissism fixed the libido at the level of the organs and their functions during an early, objectless stage, the search for the object indispensable to the formation of the ego led to a finding of it in the subject’s own body, still experienced as external. This process preceded the encounter with the object proper in the outside world, which would, in a second stage, inaugurate an “acquired” psychic narcissism, nourished and regenerated by the earlier basic narcissism and locked in a complex struggle with the ego.

This kind of very early functioning, at the start of extrauterine development, affected not only the relationship to the subject’s own body but also the relationship to thought (still, however, within the context of the distinction between inner and outer worlds),

and Tausk was led into a whole discussion of the mechanism of hallucinatory representation. In the last reckoning, the important polarity for him was not that between the sexes but that between object-libido and narcissistic libido, as revealed by the regressions characteristic of schizophrenia, which also showed sites of libidinal stasis in the “physiological” sense.

At the very early infantile stage following a first renunciation—that of the mother’s protection—the whole body was experienced as a genital organ, and the male subject wished to “creep back” into the genital from which he had emerged. The image of the genital organ—as the representative of sexuality—had been preserved in the form of a figurative representation, in the form of language. The machine aspect taken on by the influencing apparatus argued strongly for the idea that it was a projection of the body considered in its entirety as a genital organ, threatened in its narcissistic posture, independent of the intentions of the ego, and hence subject to an external will.

Although it was reasonable to speak of “somatic paranoia” with respect to the construction of the machine, the fact remained that, in contrast to paranoia, it was the persecuted in this case, not the persecutors, who were organized in a kind of systematic passive plot: The subject’s dear ones or love objects were subordinated to a narcissistic object-choice by identification, while the exigent persecutor was eliminated by a paranoid mechanism.

Tausk concluded his paper by evoking the astonishment of the young boy when he becomes aware for the first time of his erection, which he experiences as independent of the ego, as imperfectly controlled, and as part of the external world. Curiously, Tausk never returned in his study to his initial report that his patient Nataliya A. had been completely deaf for several years as the result of a recurrent middle-ear infection that obliged her to communicate with those around her by means of the written word.

This article is considered the main legacy of Tausk, whose brilliant career was cut short by his suicide in the year of its publication (1919). It is rife with more or less well-worked-out ideas, including, for instance, the casual mention of the notion of an ego “the chief weapon of which is the intellect” (p. 48). One may readily imagine the multifarious responses it elicited and the many rereadings of it that developments in psychoanalysis would later make possible; one has merely to consider how many

ideas it addressed: hallucination, the psychic, the somatic, the psychosomatic, the “ego,” narcissism, the object, and—unnamed but clearly present—seduction. Tausk deployed all of these after his own fashion, often distinct from Freud’s approach. But, in his text as in the footnotes, he emphasized time and again (perhaps even too often?) how great an inspiration Freud had been for him, and how the relationship of the two men was comprised of enigmatic encounters, and how this reflected the difficulty of their relationship.

MARIE-THÉRÈSE NEYRAUT-SUTTERMAN

See also: Ego boundaries; Narcissism; Splitting of the ego; Tausk, Viktor.

### Source Citation

Tausk, Viktor. (1933 [1919]). Über die Entstehung des Beeinflussungsapparates in der Schizophrenie. *Internationale Zeitschrift für Psychoanalyse* 5, 1–33. On the Origin of the “Influencing Machine” in Schizophrenia. Translated by Dorian Feigenbaum, *PQ* 2 (1933). Reprinted in Robert Fliess, ed., *The Psycho-Analytic Reader*. New York: International Universities Press.

### Bibliography

- Gillibert, Jean. (1975) Postface to Viktor Tausk, *Oeuvres psychanalytiques*. Paris: Payot.
- Major, René. (1978) Dissidence du corps ou “L’État sans tête.” In *L’Agonie du jour*. Paris: Aubier-Montaigne.
- Neyraut-Sutterman, Marie-Thérèse. (1975) Preface to Tausk, *Oeuvres psychanalytiques*. Paris: Payot.
- Roazen, Paul. (1969) *Brother animal*. New York: Knopf.
- Shentoub, Salem A. (1984) De la Machine à influencer à la suggestion. In *L’Impact de la suggestion dans la pratique psychanalytique*. Paris: Institut Psychanalytique de Paris.

## “ON THE SEXUAL THEORIES OF CHILDREN”

Freud’s article “On the Sexual Theories of Children” was first published in the same periodical as “‘Civilized’ Sexual Morality and Modern Nervous Illness” (1908d). In fact it is part of a whole set of writings, beginning with the *Three Essays* (1905d), in which Freud developed the themes of childhood sexuality and of the role, not just of childhood sexuality but of sexuality in general, in the face of the demands of civilization. These issues are illustrated by the case of “Little Hans”

(1909b), and further explored in *Leonardo da Vinci and a Memory of His Childhood* (1910c) and in the “Rat Man” case history (1918b [1914]).

In connection with the sexual theories of childhood Freud here evokes various repressed primal ideas (among them ideas of a woman with a penis, castration, and the sexual use of mouth or anus) that are to be met with as readily in dreams and folklore as in neurotic symptoms and perversions. He bases his understanding on both the direct observation of children and on the unconscious memories of neurotics, isolating a number of juvenile theories that he considers typical.

The child’s curiosity about origins (“Where do babies come from?”) arises, according to Freud, from a “vital exigency” (*Lebensnot*), namely the need to guard against the birth of younger siblings with whom parental love must be shared. This question is the point of departure of an “instinct for research” which will continue to operate independently.

The theories that the child conceives are directly related to its own sexuality, which means that they are true, albeit in a distorted way. Freud identifies three typical theories. The first consists in the attribution to all human beings, including females, of a penis—whence the belief in a castration that accounts for the actual configuration of the woman’s genitalia. A second theory concerns birth. This is the cloacal theory, according to which the baby is evacuated like a stool from the mother’s body. The third deals with parental coitus, picturing it as a struggle in which the father is attacking the mother.

These theories are all products of a curiosity that deconsecrates the parents by portraying them as engaged in dirty or forbidden activities (fantasy of the primal scene). The wish to know (*Wissbegierde*) is a sexual wish, and in Freud’s view the source of our intellectual interest in riddles.

SOPHIE DE MIJOLLA-MELLOR

*See also:* Castration complex; Fantasy; Femininity; Nuclear complex; Penis envy; Secret; Sexual theories of children; Thought; Truth.

### Source Citation

Freud, Sigmund. (1908c). Über infantile Sexualtheorien. *Sexual-Probleme*, IV, 763–779; *G.W.*, VII, 171–188; On the sexual theories of children. *SE*, 9: 209–26.

### Bibliography

- Freud, Sigmund. (1905d). Three essays on the theory of sexuality. *SE*, 7: 123–243.
- . (1908d). “Civilized” sexual morality and modern nervous illness. *SE*, 9: 177–204.
- . (1909b). Analysis of a phobia in a five-year-old boy. *SE*, 10: 1–149.
- . (1910c). Leonardo da Vinci and a memory of his childhood. *SE*, 11: 57–137.
- . (1918b [1914]). From the history of an infantile neurosis. *SE*, 17: 1–122.

---

### “ON TRANSIENCE”

“On Transience” was written by Freud in November, 1915, at the invitation of the Goethe Society of Berlin for a commemorative volume scheduled to appear the following year, *Das Land Goethes 1914–1916*. According to H. Lehmann (Schur, 1972), the characters referred to, that is the taciturn friend and the young poet, are respectively Lou Andreas-Salomé and Rainer Maria Rilke. This has not been confirmed, although Rilke visited Freud one month after the preparation of the text, in December, 1915 (letter to Sándor Ferenczi, December 24, 1915).

This short essay, over which hover the background of war and death that were prevalent at the time, was written the same year as Freud’s “Thoughts for the Times on War and Death” (1915b) and *Mourning and Melancholia* (1917a [1915]). These three essays constitute a whole focused on the notion of mourning. The theme of the relationship between mourning and melancholia had already been broached in Manuscript G (1950a, January 7, 1895): “melancholia consists in mourning over loss of libido” (p. 201). In “On Transience” the approach is one of a moral philosophical defense of the love of life when confronted with a depressive pseudo-wisdom, but it also contains some of Freud’s thoughts on culture and time.

In the essay Freud describes a conversation that takes place one summer day between a taciturn friend and a young poet who suffers from an inability to enjoy the beauty of nature because it will disappear during the coming winter. For Freud the waning of beauty leads to two different mental concepts: a painful disgust, related to the devaluation of the object, which can no longer keep the promise of pleasure, and

a revolt against the reality of facts, that is, the denial of time, which essentially corrupts. Freud begins by rejecting the second concept as being an illusion resulting from desire (“what is painful can also be true”). He then reverses this concept, providing several justifications for his argument: the objects are often less transient than we are and therefore we have no reason to deplore their loss, their transience confers upon them a supplementary charm, the value of things is independent of their duration.

As in the story of the cauldron, these arguments cancel each other out and are hardly convincing. There is no point in the poet torturing himself further for his own transience. Market logic (“what is rare is expensive”) implies either a position of omnipotence with respect to the object and the rivals that want to hold of it, or a romantic, or even masochistic, identification with the object’s transience, the presentiment of death adding to the worth of the object, as if mourning were taking place during the object’s lifetime.

Freud’s most interesting argument comes later and can be summarized as the affirmation that transience does not alter the object’s value, which is independent of time. This dissociation implies that value doesn’t disappear, even when there is no one to cathect to it as such. This paradoxical argument is combined with another that states that, unless the concept of value is isolated, there will be nothing left to cathect to because everything is transient. The atemporal nature of value connects the poet’s complaint about transience to its subjective and narcissistic dimensions when he complains that the object is not isomorphous to him in its duration. This short, penetrating essay is driven by the notion of mourning and the possibility of expressing and overcoming it.

In “On Transience” Freud introduced an original aspect of mourning, the “anticipatory mourning” of the object, which consists in the rejection of its cathexis to avoid suffering from its loss. Anticipatory mourning is a mechanism of narcissistic defense that denies the libidinal attachment as it is being developed. By debasing any possible relationship, the subject also debases a part of himself in the hope that the remainder will be preserved from suffering. This withdrawal of libido in the face of anything that is liable to be transient is a form of protection against the depressive catastrophe that mourning would entail for certain subjects. This exclusion of the object differs from

the work of mourning and the hate-filled attachment of the melancholic individual to an object.

SOPHIE DE MIJOLLA-MELLOR

*See also:* Mourning; Time.

**Source Citation**

Freud, Sigmund. (1916a [1915]). *Vergänglichkeit. Das Land Goethes 1914–1916*. Gedenkbuch, in *Berliner Goethebund*: Stuttgart; *G.W.*, 10, 358–361. On transience. *SE*, 14: 303–307.

**Bibliography**

Freud, Sigmund. (1950a [1887–1902]). Extracts from the *Fliess papers*. *SE*, 1: 173–280.

Schur, Max. (1972). *Freud: Living and dying*. New York: International Universities Press.

---

**ONTOGENESIS**

Ontogenesis is a theory of the development and structuring of the individual that takes into account the individual’s origins and the conditions of his or her development. Sigmund Freud always associated the ontogenesis of the human subject with phylogenesis, adopting a biogenetic perspective.

Ontogenesis comprises the developmental processes and acquisitions specific to the individual, in contrast to phylogenesis, which involves the processes of evolution and acquisition particular to a species. Ontogenesis and phylogenesis are not independent from one another: Individual acquisitions are only possible within the fixed limits of the species.

Defining ontogenesis, or the development of the individual, requires examination of what constitutes the mind and what the primary conditions of its organization are. What is called for is nothing less than a clear understanding of the origins, developmental stages, and earlier states of an individual’s history.

At the end of the nineteenth century, psychology found fertile soil in Darwin’s overarching theory of the evolution of animal species. It was believed at the time that the level of functioning of an earlier species was retained in a virtual state in later species. As Ernst Haeckel famously put it: “Ontogeny recapitulates phylogeny.” Haeckel and other nineteenth-century

evolutionist thinkers held that in human beings, the development of the fetus to adulthood (ontogeny) paralleled, in brief, the entire history of the species (phylogeny).

Meanwhile, the British neurologist John Hughlings Jackson hypothesized a hierarchical organization of the central nervous system, showing that the suspension of control from the higher centers freed up archaic automatic responses in the lower centers that correspond to earlier phases in development. Freud drew inspiration from this model with the notion of “regression.” In France, Henri Ey based his theory of organodynamism on Jackson’s “dissolutions.”

At the time, the prevailing idea was that some functions with adaptive value for lower animal species persisted in a virtual state and could be reactualized by pathology: failure of control at a higher level liberated lower levels in the hierarchy. The idea that pathology liberated a less differentiated, more “automatic” level of functioning, dating from an earlier stage in individual or species development, influenced many authors, including Freud and Pierre Janet.

Thus Freud, from his earliest writings, implicitly adopted a biogenetic conception of human sexual development. Along with Wilhelm Stekel, Wilhelm Bölsche, Granville Stanley Hall, and many others, he applied Haeckel’s “fundamental biogenetic law” to the question of sexual development.

If the child, in its growth, recapitulates the history of the species, Freud concluded that it must, by extension, recapitulate the sexual history of the species. In other words, the prepubescent human being must have the innate capacity to experience all the archaic forms of sexual pleasure that characterized the adult stages of our distant ancestors. In “Some Thoughts on Development and Regression—Aetiology,” the twenty-second of his *Introductory Lectures* (1916–1917a), Freud wrote of the development of the ego and libido that “both of them are at bottom heritages, abbreviated recapitulations of the development which all mankind has passed through from its primaeval days over a long period of time” (p. 354).

This biogenetic logic not only subtended Freud’s thoughts on the “polymorphously perverse” nature of infantile sexuality, but also later buttressed other developments in his theory. The concepts of “fixation” (arrested or inhibited development), “regression” (linked to Jackson’s general notion of “dissolution”),

and “perseveration of early impressions” (after Wilhelm Roux’s model of embryological experiments) all emerged from a developmental perspective to account for the organization of the neuroses.

Freud pursued the logic of recapitulation in a footnote added in 1915 to his *Three Essays on the Theory of Sexuality* (1905d), where he insisted that each major “pregenital” stage in infantile sexual development preserved a specific inheritance from this phylogenetic influence. From the same perspective, mental pathology was considered a return of past stages of ontogenetic and phylogenetic development that are integrated, and at the same time rediscovered. For Freud, symptom formation actualized the past, and psychoanalytic treatment was itself a therapeutic form of remembering.

Seeking the origins of Oedipal conflict, Freud detailed a series of three primal fantasies—seduction, castration, and the primal scene—that he considered to be a given from the outset and at the source of all mental organization, beyond the traumatic events of the individual’s history. The presumed universality of the Oedipus complex led him to believe that in each individual there was an embryonic version of these fantasies that are found in all cultures, as the phylogenetically transmitted trace of the murder of the father by the primitive horde.

The neo-Lamarckian perspective of Freud and his phylogenetic theories have received a good deal of criticism, despite Frank J. Sulloway’s study, *Freud—Biologist of the Mind* (1979), which presented the full scope of Freud’s constructions. The fact is that in early twenty-first century cultural and linguistic transmission, along with communication in one way or another, from the parental or grandparental unconscious, are far more readily invoked to define the way in which the psyche’s earliest constitutive fantasies originate than a hypothetical inscription in the genetic material of the species. Research on transgenerational effects (Kaës, 1993) takes this direction, as does Jean Laplanche’s “general theory of seduction” which argues that the maternal unconscious transmits sexualized messages, or “enigmatic signifiers,” to the child.

Present day research is concerned less with discovering the ultimate origins of the formation of the individual than with accounting for the conditions under which it comes about. As of 2005, the ontogenetic approach—that is, research into the development of the individual or into the genesis of the



Oedipus complex—concentrates on two main lines of inquiry. The first is libidinal development, taking into consideration the successive phases of mental organization, with a focus on the predominant erotogenic zone around which psychic excitation is centered and fantasies organized. The second focuses on the development of object relations in their relationship with the development of the ego.

JEAN-FRANÇOIS RABAIN

*See also:* *Civilization and its Discontents*; “Claims of Psycho-Analysis to Scientific Interest; Cultural transmission; Darwin, Darwinism, and psychoanalysis; Fatherhood; Processes of development; Heredity of acquired characters; Intergenerational; Lack of differentiation; Maternal reverie, capacity for; Phylogenesis; Prehistory; Primitive horde; *Thalassa. A Theory of Genitality*; *Totem and Taboo*.

### **Bibliography**

Freud, Sigmund, (1905d) *Three Essays on the Theory of Sexuality*. *SE*, 7: 123–243.

———. (1916–1917a). Introductory lectures on psychoanalysis. *SE*, 16.

Kaës, René (1993). Introduction. In René Kaës, et al., *Transmission de la vie psychique entre générations*. Paris: Dunod.

Sulloway, Frank J. (1979). *Freud—biologist of the mind*. London: Burnett.

---

## **OPERATIONAL THINKING**

The expression *operational thinking* was introduced by Michel de M'Uzan and Pierre Marty in 1962 at the Barcelona psychoanalytic congress, based on a so-called psychosomatic approach. It is conceived as a deficient form of thought that is quasi-conscious, without organic links to dreaming, fantasy, or symbolization. It is almost instrumental in nature, and suggests the idea of deementalization. Like “basic depression,” operational thinking is said to function as a defensive system and possibly as a structural, antitraumatic factor; in this role, however, it would be liable to introduce an element of disorganization that could lead to somatic disorders. Early on, operational thinking was cast in a metapsychological light within the framework of Freud's first topography; later, it played a role in the second topography (or structural model) and in the second theory of the drives.

This type of thinking repeats and illustrates action, preceding or following it within a limited temporal span. It does not work according to an associative system and elements in it are treated as pieces of the present; it is ostensibly without symbolic scope or trophic sublimatory value. It is thus subjected to reality without signifying it, causing a reduction in the libidinal value of the elements of this reality. These criteria cause it to be conceived as a psychopathological type of thought.

Operative thinking is also linked in this view to deficiencies in the play of identification as well as in all emotional involvement; it renders all relationships “blank” inasmuch as others are considered to be identical to the subject, evoking “projective duplication.” Operational thinking reflects behavior that, while socialized, appears as if it is imposed by purely adaptational requirements. By placing emphasis on the economic dimension, it can be described as an archaic breakdown of the evolution of the primary process with libidinal degradation; the processes of investment thus remain at the archaic level, favoring the instrumental functions of life—to the detriment of adequate secundarization—with pseudo-mastery standing in for a sound integration of reality.

This notion has become a clinical construct in psychosomatic disorders and has been theoretically and clinically fleshed out, highlighting the traits that are dynamic in dimension, notably on the relational level, in *L'investigation psychosomatique* (Psychosomatic research; 1985). This book dealing with operational thinking and served as the rallying point for the group of psychoanalysts dubbed the École psychosomatique de Paris (Psychosomatic School of Paris).

Marty has extended the notion of “operational” to other aspects of mental life besides thinking, and these together, in his view, made up “operational life.” Combining this with the notion of basic depression in the first volume of *Les mouvements individuels de vie et de mort* (The individual movements of life and death; 1976), he defined the framework of a quasi-structural approach that is both a defensive system against trauma and a participating element in what he called “progressive disorganization.”

The original theorists of operative thinking privileged the role of the first Freudian topography and—Marty in particular—the flawed category of the preconscious. It should be noted that in the context of Marty's model of progressive disorganization, the

death instinct is not the same thing as the death drive in Freudian theory. Present-day authors tend to place operational thought in the context of the second Freudian topography and the death drive, including self-destructiveness.

ALAIN FINE

*See also:* Actual; Essential depression; Marty, Pierre; Secondary revision.

### **Bibliography**

Fine, Alain. (1995). L'opérateur comme négatif de la réalité psychique. *Revue française de psychanalyse*, 59, (1), 173–186.

Marty, Pierre. (1976). *Les Mouvements individuels de la vie et de mort* (Vol. 1: *Essai d'économie psychosomatique*). Paris: Payot.

———. (1980). *Les Mouvements individuels de la vie et de mort* (Vol. 2: *L'Ordre psychosomatique*). Paris: Payot.

Marty, Pierre, and de M'Uzan Michel (1963). La pensée opératoire. Intervention sur le rapport de M. Fain et Ch. David: Aspects fonctionnels de la vie onirique. XXIIIe Congrès des psychanalystes de langues romanes, Barcelone, 1962. *Revue française de psychanalyse*, 27, 345–356.

Smadja, Claude. (1998). Le fonctionnement opératoire dans la pratique psychosomatique: LVIIIe Congrès des psychanalystes de langue française des pays romans à Lausanne. *Revue française de psychanalyse*, 62, 5, 1367–1440.

## **OPERE (WRITINGS OF SIGMUND FREUD)**

The Italian edition of the *Opere* (Writings of Sigmund Freud) in twelve volumes was begun in 1966 under the direction of Cesare Musatti and was completed in 1980. The essays that were not published in the *Opere* were collected into a volume of *Complementi* in 1993, with a critical apparatus by Angela Richards and Ilse Grubrich-Simitis.

Each of the twelve volumes is accompanied by an introduction by Musatti and a historical essay that describes the context in which Freud's writings can be placed. Each text is also accompanied by an editor's preface, which includes a list of publications and translations. Volume twelve is an index and includes keywords, together with bibliographical references, lists of publications, and a concordance with the complete

works in English (*Standard Edition*) and German (*Gesammelte Werke*).

The Italian edition duplicates the unrevised *Standard Edition* prepared by James Strachey (1953–1974) and refers to it; consequently it does not include the so-called preanalytic works or the fragments of analytic works revised by Freud, the letters, or minutes of the Vienna Psychoanalytic Society. Like the English, German, and French editions, the Italian edition is not a critical history because it does not discuss Freudian politics in terms of the circular letters, nor does it enable the reader to grasp Freud's process of development through his writing.

The Italian edition was directed by Paolo Boringhieri, who, with Cesare Musatti, turned over the corrected edition to Renata Colorni and various translators. There were few psychoanalysts in this group other than Giacomo Contri and Elvio Fachinelli. Many translators were unfamiliar with psychoanalysis, while Freud himself wanted to have his work translated only by those trained in psychoanalysis.

Every translation is linguistically situated in the period in which it is undertaken and the Italian edition is no exception. It reflects the psychoanalytic culture of the 1960s, the language that corresponds to the period, and a concept of psychoanalysis as understood by practitioners like Edoardo Weiss. Because it promoted genuine interest in psychoanalysis, the *Opere* represents the most important psychoanalytic creation yet produced in Italy.

GIANCARLO GRAMAGLIA

*See also:* Italy; Musatti, Cesare.

### **Source Citation**

Freud, Sigmund. (1966–1980 [1886–1938]). *Opere*. Turin: Boringhieri.

### **Bibliography**

Grubrich-Simitis, Ilse. (1993). *Back to Freud's texts: Making silent documents speak*. New Haven, CT, and London: Yale University Press, 1996.

Ranchetti, Michele. (1993). Prefazione. In *Opere, Complementi*. Turin: Boringhieri.

## OPHUIJSEN, JOHAN H. W. VAN (1882–1950)

A physician, psychiatrist, and psychoanalyst, Johan H. W. van Ophuijsen was born on November 12, 1882, in Sumatra, Dutch East Indies, and died on May 31, 1950, in Detroit, Michigan. He was sent to Holland for secondary schooling at age thirteen. He graduated with an MD from Leiden University in 1909 and went for four years to Zürich to the clinic of Eugen Bleuler. He had analysis with Jung and analyzed some English-speaking patients. He was secretary of the Züricher Psychoanalytic Society and as such present at the meeting of Freud and Jung about the escalation of their conflicts in November 1912 in Munich, together with Karl Abraham and Ernest Jones.

Back in Holland in 1913 he worked at the psychiatric clinic of Jelgersma in Leiden and participated in meetings with some colleagues who were also interested in psychoanalysis, partly analyzed by Jung. Together they founded the Dutch Psychoanalytical Society in 1917. Van Ophuijsen was the link between Dutch and international psychoanalysis, through his reports in the *Internationale psychoanalytische Zeitschrift* and the Dutch Medical Journal. In 1922 he went for a few years to Berlin for further analysis with Abraham, cooperating with Max Eitingon and Hanns Sachs, who were developing the tripartite training model at the Berlin Institute. After his return again to Holland he settled in the Hague and became president of the Dutch Psychoanalytical Society, fervently defending the desirability of lay analysis and the tripartite training model against the opposition of most of the other members.

From 1927–1934 he was treasurer, and from 1936–1938 vice-president of the International Psychoanalytical Association (IPA). His international involvement caused much resentment among the Dutch. In 1932 he was on the committee to save the *Internationaler Psychoanalytischer Verlag* in Vienna from financial distress. His appeal to the Dutch analysts for a financial contribution raised opposition in the Society, where earnings from analytic practice were poor. The opposition rose to an uproar when in 1933 four German Jewish refugees came to Holland, with the active cooperation of van Ophuijsen, who hoped that they would play an important role in Dutch analytic training. In fact, he had asked Karl Landauer to join him in the

Psychoanalytic Institute, which he had founded a few years earlier. The Dutch analysts feared that they would be overshadowed and lose the limited earnings they had, and refused to accept the immigrants as society members. In a stormy meeting, van Ophuijsen resigned as president of the society and one week later also as a member, followed by five others. He founded a new society, the Society of Psychoanalysts in the Netherlands, which was open to the German immigrants. However, in 1937 van Ophuijsen emigrated himself to Johannesburg (South Africa) together with his analyst Fritz Perls (also a German immigrant and later the founder of Gestalt therapy) and one year later to the United States, where he joined the psychiatric staff of some New York hospitals and became a teacher at the New York Psychoanalytical Institute. Later he settled in Detroit as an analyst and teacher. He continued his psychoanalytic practice until the day of his death.

HAN GROEN-PRAKKEN

*See also:* Secret Committee; Netherlands; Switzerland (German-speaking).

### Bibliography

- Brinkgreve, Christien. (1984). *Psychoanalyse in Nederland. Een vestigingsstrijd*. Amsterdam: Arbeiderspers.
- Bulhof, Ilse N. (1983). *Freud en Nederland*. Baarn: Ambo.
- Greon-Prakken, Han. (1993). The psychoanalytical society and the analyst, with special reference to the history of the Dutch Psychoanalytical Society 1917–1947. In Greon-Prakken and Ladan (Eds.), *Dutch Annual of Psychoanalysis, 1993* (pp. 13–37). Amsterdam and Lisse: Swets & Zeitlinger.
- Jones, Ernest. (1957). *Sigmund Freud. Life and Work*. London: Hogarth.
- Klein, Emanuel. (1951). Obituary Johan H. W. van Ophuijsen. *International Journal of Psycho-Analysis*, 32, 134–135.

### OPTICAL SCHEMA

Lacan borrowed his optical schema from physics. He used it to illustrate the role of the real Other in constructing both the body and the specular image as the model for the ego.

Lacan introduced this schema in his seminar of 1953–1954, on *Freud's Papers on Technique*. He took his cue from Freud's reference to an optical schema in

FIGURE 1

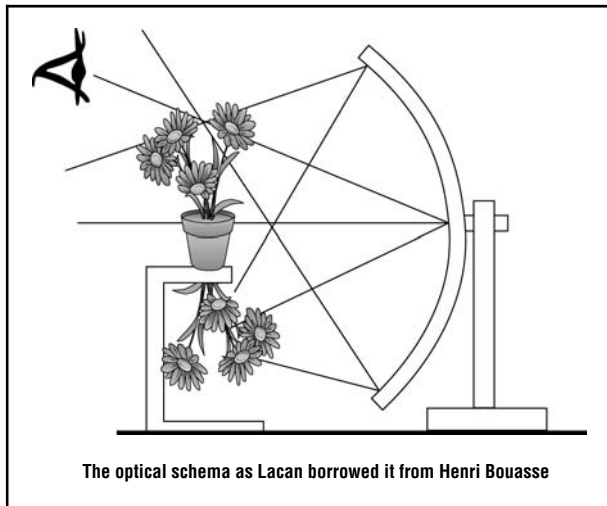

*The Interpretation of Dreams* (Freud, 1900a, p. 536; Lacan, 1953–54, 74–76). Lacan first used the schema to illustrate the reciprocal play of the real, the imaginary, and the symbolic in Melanie Klein’s case of “Little Dick.”

Because of the optical properties of concave mirrors, a bouquet of flowers that is hidden from the visual field of the viewer emerges above the vase. And if the eye of the viewer is properly placed, an image of flowers in the vase is produced as a whole or a unity (Figure 1).

The illusory presence of the flowers in the vase represented a baby’s relation to his body, but this is something the baby cannot see. To create a “substitute for the mirror-stage” (1953–54, p. 74), Lacan introduced a plane mirror (Figure 2).

In the virtual space beyond the mirror, a specular image is created,  $i'(a)$ , and this is where the baby as

FIGURE 2

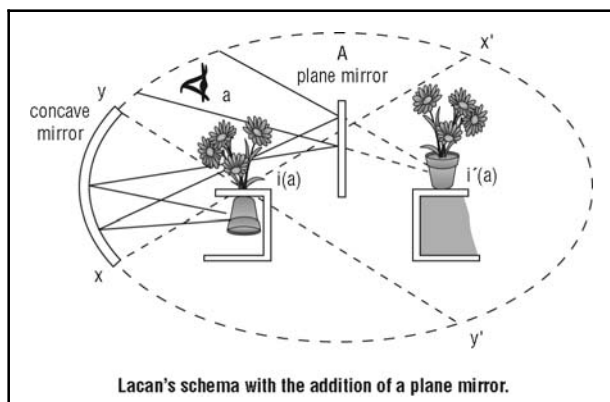
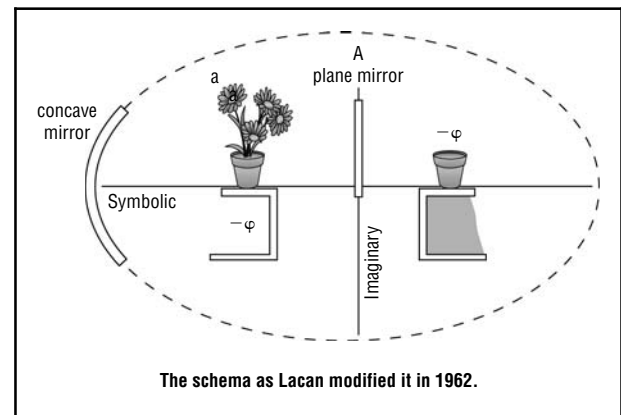

FIGURE 3



subject recognizes the image as its ego. This represents the dimension of radical alienation in ego formation as it occurs in relation to the image of a fellow being—a process that is specific to secondary narcissism and the ideal ego.

Lacan returned to the optical schema in his seminar on *Transference* (1960–61), but then the plane mirror shows the effect that the parental Other’s look has on the baby’s organism. This look allows the baby to sense its own body, modeled on its specular image. Lacan even gave the Other a role in the formation of primary narcissism. This schema allows for an approach to the treatment of early psychopathologies prior to the mirror stage (Laznik-Penot, 1993).

In his seminar on *Anxiety* (1962–63), Lacan redesigned the schema in response to a question asked by André Green regarding the relations between the real, the imaginary, and the symbolic (Figure 3).

This version of the schema presented two principle modifications:

1. The flowers, a metaphor for libidinal investment, were no longer the reflection of a bouquet hidden under the table, but rather the effect of a lack, which Lacan wrote as  $-\varphi$ .
2. The inscription of lack,  $-\varphi$ , also appeared behind the plane mirror, in the imaginary field. Thus the new version of the schema emphasized the constitutive role of lack in any mental functioning.

Lacan used the plane mirror in two different ways. Sometimes it referred to the mirror of the mirror stage, still very much centered on the structuring character of the image itself. And sometimes it

referred to a mirror without a reflection, that is, a representation of the Other's gaze. Indeed, our understanding of this schema has been modified retroactively by the introduction of the concept of the big Other; nevertheless, it is still most often understood in its strictly intrapsychic dimension.

MARIE-CHRISTINE LAZNIK

See also: Ego ideal/ideal ego; Phallus; Look/gaze; Topology.

### **Bibliography**

- Freud, Sigmund. (1900a). The interpretation of dreams. *SE*, 4–5: 1–751.
- Lacan, Jacques. (1988). *The Seminar of Jacques Lacan, Book I, Freud's Papers on Technique (1953–1954)*. (John Forrester, Trans.). New York: Norton.
- . *Le Séminaire-Livre IX, L'identification* (1961–62). (unpublished seminar).
- . (2004). *Le Séminaire-Livre X, L'angoisse [Anxiety]* (1962–1963). Paris: Seuil.
- Laznik-Penot, Marie-Christine. (1993). Du ratage de l'instauration de l'image du corps au ratage de l'installation du circuit pulsionnel. In *La clinique de l'autisme*. Paris: Point Hors Ligne.

## **ORALITY**

*Orality* is a major component of the organization of the libido during the first, pregenital phase of its development; it is thus an essential aspect of psychosexuality.

Freud gave his first overall description of the phases of the libido in his *Three Essays on the Theory of Sexuality* (1905d). Sucking, initially autoerotic, is the earliest expression of the instincts. It is anaclitically supported by a function necessary to the preservation of life, the absorption of nourishment. Pleasure is therefore linked to an erotogenic zone, the mouth, and more specifically to the mucous membranes of the lips and mouth. This pleasure will later be found again in kissing, in the pleasure of eating, drinking, or smoking, and so forth, and it can become the basis for perverse practices. This excitability may persist throughout life, linked—to some degree—to genitality. Due to the very fact of this link, oral pleasure may be repressed and eating disorders may appear.

In a note added to the *Three Essays*, in 1915 Freud specified that during the oral phase, “the sexual aim consists in the incorporation of the object—the prototype of a process which, in the form of identification, is later to play such an important psychological part” (1905d, p. 198). Orality is thus also a mode of relationship to the object. Freud elaborated on this idea in connection with the psychopathology of instances of the ego's loss of the objects it has cathected. “The ego wants to incorporate this object into itself, and . . . it wants to do so by devouring it,” he wrote in “Mourning and Melancholia” (1916–1917 [1915], p. 250). At the stage of the oral organization of the libido, love of the object still coincides with the destruction of the object, according to Freud in *Beyond the Pleasure Principle* (1920g).

Freud's perspectives were slightly modified with his introduction of the second topography (or structural theory). During the oral phrase, he then argued, because the three agencies were not yet differentiated, object-cathexis was still based on identification. “Later on object-cathexes proceed from the id, which feels erotic trends as needs,” he wrote in *The Ego and the Id* (1923b, p. 29).

Since erotogenic masochism is a part of all phases of libidinal development, Freud held (1924c) that the fear of being devoured by the totem animal (the father) emanated from the primitive oral organization.

In his important article “The Influence of Oral Eroticism on Character Formation,” (1924) Karl Abraham associated envy and jealousy with oral erotism. Adopting Abraham's thesis, Freud in his *New Introductory Lectures on Psycho-Analysis* (1933) distinguished two substages of the oral phase: The first is preambivalent (conflict-free); the second, linked to the development of dentition, is marked by ambivalence owing to conflict between the desire to bite the breast and inhibition of that desire, and is thus described as “oral-sadistic.”

Abraham's and Freud's views were the basis for Melanie Klein's theory that premature activation of the oral-sadistic tendencies is the cause of hypertrophied sadism and strongly ambivalent object-relations. More generally, it was with reference to the oral stage of libidinal development that she elaborated her notion of a close bond between destructive and libidinal impulses. She contended that anxiety stems essentially from the instinctual dangers of the destructive tendencies and

their repression. This is the source of what later in her theoretical work would become the love/hate opposition marking the earliest relations to the breast, and its fundamental split into good breast and bad breast.

DOMINIQUE J. ARNOUX

*See also:* Anorexia nervosa; Basic Neurosis, The—Oral regression and psychic masochism; Bulimia; Demand; Eroticism, oral; “Mourning and Melancholia; Partial drive; Phobias in children; Pregnancy, fantasy of; Oral-sadistic stage; Oral stage; Stage (or phase); Stammering; Sucking/thumbsucking; Wish for a baby.

### **Bibliography**

- Abraham, Karl. (1949). The influence of oral erotism on character formation. In *Selected papers of Karl Abraham, M.D.* (Douglas Bryan and Alix Strachey, Trans.). London: Hogarth and the Institute of Psycho-analysis. (Original work published 1925)
- Freud, Sigmund. (1905d). Three essays on the theory of sexuality. *SE*, 7: 123–243.
- . (1916–17g [1915]). Mourning and melancholia. *SE*, 14: 237–258.
- . (1920g). Beyond the pleasure principle. *SE*, 18: 1–64.
- . (1923b). The ego and the id. *SE*, 19: 1–66.
- . (1924c). The economic problem of masochism. *SE*, 19: 155–170.
- . (1933a [1932]). New introductory lectures on psycho-analysis. *SE*, 22: 1–182.
- Klein, Melanie. (1932). *The psycho-analysis of children*. London: Hogarth.

---

## **ORAL-SADISTIC STAGE**

The oral-sadistic phase of infantile libidinal organization is the second part of the oral stage, as described by Karl Abraham; it is also known as the cannibalistic phase. During this period incorporation means the destruction of the object, so the relationship to the object is said to be ambivalent.

It was in a passage added in 1915 to his *Three Essays on the Theory of Sexuality* that Freud introduced the notion of an “oral” organization that he also described as “cannibalistic”: “the sexual aim consists in the incorporation of the object—the prototype of a pro-

cess which, in the form of identification, is later to play such an important psychological part” (1905a, p. 198). The evocation of “cannibalism” served to underscore certain features of the oral object-relationship: the incorporation of the object and its characteristics, identification with it, and, at the same time, greed and destructiveness.

Abraham (1927 [1924]) subdivided the oral stage into two parts: first, an early oral phase dominated by the pleasure of sucking and described as “preambivalent,” because the breast is not yet conceived as at once good and bad, both frustrating and gratifying; and secondly, an oral-sadistic or “cannibalistic” stage, occurring later, during the second six months of life, and contemporaneous with teething, which sees the emergence of the wish to bite and to incorporate the object, destroying it in the process. Instinctual ambivalence makes its appearance during this second phase, as incorporation becomes destructive. The oral-sadistic phase is thus characterized by the advent of aggressiveness, by ambivalence, and by the anxiety associated with the destruction of the loved object and the fear of being devoured in turn by that object. Elsewhere, in the context of a discussion of interaction, attention has been drawn to the way in which the child’s cannibalistic instincts can revive those of the mother (Golse, 1992).

Freud used the model of cannibalistic devouring and the intrapsychic effects of ambivalence in his study of melancholia (1917e, pp. 249–50). In mourning, he argued, the lost object was assimilated into the ego, incorporated as in the totem meal. Once magically incorporated in this way, it was conflated with the ego, which could either draw strength and power from this (as in identification or the totem meal), or, alternatively, fall victim to attacks from within from this ambivalently cathected object (as in melancholic self-reproach).

Melanie Klein radicalized Abraham’s account of a destructiveness linked to orality and to object-love, going so far as to say that libidinal development as a whole is completed only once the innate destructive instincts have been integrated into it. In her view the whole of the oral stage was oral-sadistic in nature, indeed it was the high point of infantile sadism. The libidinal wish to suck and incorporate was combined with the destructive aim of scooping out and emptying the object. In her *Envy and Gratitude* (1957/1975, pp. 180–81), Klein defined envy of the breast as bound up with oral greed, in which the destructive component

instincts predominated: the desire to attack and destroy the object was not tempered by the gratitude generated by good experiences with the mother. This primal wish precipitated the split between the good breast to be retained and the bad breast to be expelled. Klein thus returns via this account of primal oral desire to the idea of a differentiation between ego and non-ego that is secondary to that between good and bad, as organized by the mechanisms of introjection and projection specific to the Freudian model.

JEAN-FRANÇOIS RABAIN

*See also:* Orality; Stage (or phase).

### **Bibliography**

- Abraham, Karl. (1927). A short study of the development of the libido, viewed in the light of mental disorders. In *Selected Papers on Psycho-Analysis*. London: Hogarth. (Original work published 1924)
- Brusset, Bruno. (1992). *Le Développement libidinal*. Paris: P.U.F.
- Freud, Sigmund. (1905d). Three essays on the theory of sexuality. *SE*, 7: 123–243.
- . (1916–17g [1915]). Mourning and Melancholia. *SE*, 14: 237–258.
- Golse, Bernard. (1992). *Le développement affectif et intellectuel de l'enfant*. Paris: Masson.
- Klein, Melanie. (1957). Envy and Gratitude. In *Envy and Gratitude and Other Works, 1946–1963*. Reprinted in *The Writings of Melanie Klein, vol. 3*. London: Hogarth Press; New York: Delacorte/Seymour Lawrence, 1975.

---

## **ORAL STAGE**

The oral stage is the initial mode of organization of libidinal cathexes, establishing the buccopharyngeal area and the lips as the predominant erotogenic zone—and hence as the source of the instinct operating in conjunction with the instinctual aim (incorporation) and the instinctual object (the breast).

The act of taking nourishment tends to symbolize the mother's breast and the primal link that the infant establishes with its mother. Sucking at the breast, governed by biologically programmed behavior, procures an experience of pleasure for the infant which vouchsafes the mouth its role as the first erotogenic zone.

At the same time, however, the concept of anaclysis highlights the foundational role played by the mother's ministrations and the taking of nourishment, making it possible to see how, at this first moment in development, there is an interaction between the vital sphere of need and the mental sphere of sexuality and fantasy.

Jean Laplanche has described both the dual movement of sexuality, as it first props itself upon (“anaclysis”) and then disengages itself from the realm of physiological need, and the dual shift—metaphorically, from ingestion to incorporation, and metonymically, from milk to breast (or bottle). This model underscores the importance of maternal care for the constitution of the psyche. For Laplanche, “primal seduction,” linked to the mother's sexuality, is at the root of the child's autoerotism and sexuality. Similarly, on the basis of the idea of a retroactive effect of the object of the drive upon its source, Laplanche evokes a “source-object” as the first form of internal object, constituted by autoerotism and constituting the origin of fantasy. Thus the representation of the mother's breast supplies the prototype of incorporable objects and precipitates the development of the first object-relationship.

René Spitz introduced the idea that the earliest oral experience of nursing gives rise to the representation of a “primal cavity” which orders the structuring relations between inside and outside. This “bridge from inner reception to external perception” (Spitz, 1965, pp. 61–62) may be looked upon as the matrix of the mechanisms of introjection and projection.

Oral experience thus initiates “the language of the oldest—the oral—instinctual impulses,” evoked by Freud to account for the primal rejection of the bad and incorporation of the good in the establishment of the first boundary between the self and the outside world (1925h, p. 237).

It was Karl Abraham, in 1924, who subdivided the oral stage into two parts: an early oral phase covering the first six months of life, dominated by the pleasure of sucking and described as “pre-ambivalent” because the breast is not yet conceived as at once good and bad; and a later phase, covering the second six months, known as the oral-sadistic or “cannibalistic” stage, contemporaneous with teething, which sees the emergence of the wish to bite and the fear of destroying the loved object (and of being devoured in turn by that object). Ambivalence makes its appearance during this

second phase, incorporation having become destructive. The child's cannibalistic instincts have been described as reactivating those of the mother (Golse, 1992).

Melanie Klein radicalized Abraham's account of a destructiveness linked to orality and to object-love, going so far as to say that libidinal development as a whole is completed only once the destructive instincts have been integrated into it. She maintained that sadism is at its height during the first six months of life.

The organization specific to the early, "passive" oral stage was characterized by Klein as the "swallow/be swallowed" object-relationship, by anxieties about being emptied or annihilated. The oral-sadistic stage was marked by the "devour/be devoured" object-relationship, by fear of dismemberment, and by projective identification. Fixation at the oral stage was reflected in a character type marked by greed, passivity, and dependency.

The experience of satisfaction obtained from feeding is not confined to oral pleasure, for it may involve the entirety of bodily feelings. This last consideration has been judged essential in the genesis of the feeling of identity, that is, of the self, and the first underpinnings of narcissism.

Oral introjection is also considered to underlie such other corporeal functions as cutaneous absorption, sight, hearing, respiration, and manual prehension. Contemporary work on autism has underlined the importance, in the first organizing experience of the psyche, of mouth-nipple and tongue-nipple contact, thought to convey the contrast between the elemental sensations of hard and soft (Donald Meltzer, Frances Tustin, Geneviève Haag, 1991).

JEAN-FRANÇOIS RABAIN

*See also:* Good/Bad Object (Breast); Archaic mother; Oedipus complex, early; Orality; Stage; Unconscious fantasy; Weaning.

### **Bibliography**

- Abraham, Karl. (1927). A short study of the development of the libido, viewed in the light of mental disorders. In *Selected Papers on Psycho-Analysis*. London: Hogarth. (Original work published 1924)
- Brusset, Bruno. (1992). *Le développement libidinal*. Paris: PUF.

Freud, Sigmund. (1905d). Three essays on the theory of sexuality. *SE*, 7.

———. (1925h). Negation. *SE*, 19.

Haag, Geneviève. (1991). Nature de quelques identifications dans l'image du corps. Hypothèses. *Journal de la psychanalyse d'enfant*, 10, 73–92.

Klein, Melanie. (1932). *The psycho-analysis of children* (Alix Strachey, Trans.). London: Hogarth/Institute of Psycho-Analysis; Reprinted in *The Writings of Melanie Klein* (Vol. 2). New York: Delacorte/Seymour Lawrence, 1975.

Laplanche, Jean. (1999). The drive and its source-object. In *Essays on Otherness* (John Fletcher, Ed.; Leslie Hill, Trans.; pp. 117–32.). London: Routledge. (Original work published 1984)

Spitz, René. (1965). *The first year of life: A psychoanalytic study of normal and deviant object relations*. New York: International Universities Press.

---

## **ORGAN PLEASURE**

Organ pleasure is erotic satisfaction linked to any part of the body that becomes an erogenous zone, including internal organs. It rises from the earliest phase of development of infantile sexuality and is marked by independent, autoerotic partial drives in search of sexual satisfaction.

The notion of organ pleasure is part of the framework of infantile sexuality and is intimately linked to the notion of erogenous zones. This notion appeared late in Freud's work, rising out of his theoretical extrapolations on narcissism. In "On Narcissism" (1914c), Freud studied a number of cases of pathology, as well as of normal psychology, to analyze the narcissistic functioning of the ego. In addition to psychosis and physical illness in love life, he took up the subject of hypochondria. In this connection he was led to reconsider the notion of corporeal erotogenicity, which he defined as an activity of a part of the body giving rise to sensations that excite the psychic apparatus sexually. Freud then extended erotogenicity to the level of a general property of all the organs. Thus the notion of organ pleasure was born. At the core of the libidinal economy, modifications of organic erotogenicity lead to corresponding modifications in the ego's libidinal investment.

The notion of organ pleasure is in reality a resumption of the notion of an erogenous zone, which Freud theoretically developed in *Three Essays on the Theory of*



*Sexuality* (1905d). In the chapter on infantile sexuality, Freud defined an erogenous zone as “a part of the skin or the mucous membrane in which stimuli of a certain sort evoke a feeling of pleasure possessing a particular quality” (p. 183). In infantile sexuality, the sexual goal of all partial drives remains the satisfaction of erogenous zones. This domination of the erogenous zone is tempered only by the first stirrings of pregenital organizations in the development of infantile sexuality. The notion of organ pleasure thus extends the erogenous zone beyond the skin and mucous membranes to all the internal organs, which, from the point of view of the subject’s sexuality, are conceived as having the same characteristics.

The notion of organ pleasure reappeared in Freud’s “Instincts and their Vicissitudes” (1915c) and in the *Introductory Lectures on Psychoanalysis*, on the development of the libido and the sexual systems (1916–17a [1915–17]).

The notion of organ pleasure results principally from two series of clinical observations. First, it has been linked to infantile sexual activity, such as sucking and anal activity. Second, it has been inferred by interpretation in the course of psychoanalytic treatment of neuroses, particularly hysteria. These psychoanalytic observations have shown that an organ or system of organs can substitute for the genital organs in the search for sexual satisfaction. This led Freud to connect the erogenous zones to the hysteria-generating zones. Later research on hypochondria has confirmed this point of view.

CLAUDE SMADJA

*See also:* Erotogenic zone; Hypochondria; Partial drive; Psychosexual development; *Three Essays on the Theory of Sexuality*.

### **Bibliography**

- Freud, Sigmund. (1905d). Three essays on the theory of sexuality. *SE*, 7: 123–243.
- . (1914c). On narcissism: An introduction. *SE*, 14: 67–102.
- . (1915c). Instincts and their vicissitudes. *SE*, 14: 109–140.
- . (1916–1917a). Introductory lectures on psychoanalysis. *SE*, 15–16.

---

## **ORGANIC PSYCHOSES**

In traditional psychiatric language, *organic psychoses* are psychotic states—whether acute (like *delirium tremens*) or chronic (like the senile dementias)—having a known, identified biological substrate (histological, toxic, and so on) that is directly related to the pathology. They are opposed to the *functional psychoses* (acute, like delusional fits, or chronic, like schizophrenia).

From the beginning of the nineteenth century, the term *psychosis* has been used to describe all pathologies, whatever their pathogenesis, that combine a loss of reality (deficiency in the reality-apprehension functions) with the creation of an alternative reality (hallucinations and delusional ideas). Initially, the term *organic* referred to “organ” and designated those psychoses where the symptoms are due to organ damage (the language apparatus in the dementias, for example), as opposed to functional psychoses—for example, in schizophrenia, also called *dementia praecox*, disorders of language are not caused by an organ being affected, but by a problem of function. Gradually, the term organic came to be used for all pathologies with a biological substrate, and was thus opposed to psychogenic. As of 2005, the opposition between organic psychoses and functional psychoses has fallen into disuse.

Freud never adopted this terminology, doubtless owing to the originality of his approach, which established concepts (such as the instincts, the libido, the economic theory) that make it possible to conceive of the biological and the mental in conjunction. Thus, he did not hesitate to speak of “toxic” etiology with regard to certain types of melancholia and hallucinatory psychoses, which in his view referred to anomalies in the level and/or the distribution of the libido, and which was in no way in opposition to the demonstration of psychological mechanisms.

VASSILIS KAPSAMBELIS

*See also:* Psychogenesis/organogenesis.

---

## **ORGANIC REPRESSION**

The theory of organic repression was elaborated throughout Freud’s work in order to propose a synthetic, “psychobiological” solution to the problem of pathological repression and the choice of neurosis. Civilization was considered to be built on the model of

an “organic” repression of abandoned libidinal zones, for example the abandonment of olfactory satisfactions as hominids evolved into standing upright. Throughout his life Freud tried to find a “psychobiological” solution to the question posed by the psychic organization, notably those of the choice of neurosis and pathological repression (Sulloway, 1979). The same Lamarckian and biogenetic model of human development inspired the earliest, as well as the latest Freudian discoveries, giving rise to an underlying model of psychosexual evolution meant to interpret human behavior. Many of the phylogenetic points of view that Freud promulgated after *Totem and Taboo* (1912–13a) had been adopted by him as early as the 1890s, as his correspondence with Fliess shows.

A few phases of the evolution of Freudian thought concerning the problem of repression can be distinguished, in the course of which Freud perfected complementary theories, one psychological and the other organo-phylogenetic. The instincts rooted in phylogenesis never stopped haunting his thought (Laplanche, 1993).

After abandoning the seduction theory in 1897, Freud replaced the notion of defense against real traumatic seductions linked to the environment with an organic olfactory theory of repression. He explained the propensity of man toward sexual neurosis by an excessive repression of the affects of pleasure, which were associated with certain infantile erogenous zones, such as the mouth, the nose, throat, and anus (letter to Fliess of November, 14, 1897). He took up this point of view again, in particular, in “The case of the Rat Man” (1909d), who had been a “sniffer” in his childhood, identifying people through their particular odor. In this case study he wonders whether “the atrophy of the sense of smell (which was an inevitable result of man’s assumption of an erect posture) and the consequent organic repression of his pleasure in smell may not have had a considerable share in the origin of his susceptibility to the disease” (p. 248). In later writings, *Totem and Taboo*, in 1912, then *Civilization and its Discontents* (1930a [1929]), Freud will renew this evolutionist hypothesis of a relation between sexuality, neurosis, and the erect posture of man.

However, even before abandoning his theory of seduction in the autumn of 1897, he had developed his psychological theory of repression, appealing to the notion of “organic” reversal of affect (disgust, shame),

associated with certain infantile sexual experiences. In the same “organic” perspective, he connected the acquisition of disgust and shame, in *Three Essays on the Theory of Sexuality* (1905d), to “a development that is organically determined and fixed by heredity, and can occasionally occur without any help at all from education” (p. 178–179).

For a long time, he had been considering the reaction of disgust at excrement as a phylogenetic consequence of the vertical position. He had already discussed this point of view with Fliess, referring to “abandoned erogenous zones”: “I have often had a suspicion,” he wrote him on November 14, 1897, “that something organic plays a part in repression; I was able once before to tell you that it was a question of the abandonment of former sexual zones.... The extinction of these initial sexual zones would have a counterpart in the atrophy of certain internal organs in the course of development” (*Complete Letters to Fliess*, p. 279).

On November 17, 1909, in the course of a debate at the Psychoanalytical Society of Vienna, Freud explained “that there is no repression that does not have an organic core; this organic repression consists of the substitutions of unpleasurable sensations for pleasurable ones. Probably man’s detachment from the soil is one of the basic conditions for [the formation of] a neurosis; the olfactory sense is prone, as a consequence of this detachment, toward repression, since it has become useless... the bigger the child gets to be, the further it rises away from ground” (Nunberg, p. 323). This distinction between the organic repression of childhood and the more psychological repressions of the adult corresponds to the later Freudian dichotomy distinguishing between primal repressions and secondary ones (1915d).

Subsequently, the logic of *Totem and Taboo* amplified the organic theory of repression proposed as first of all linked to odor. Along with the myth of the primitive murder of the father, “the ontogenetic acquisition of remorse, guilt and moral sense now became conceivable to Freud as a phylogenetic precipitate from the primal father complex of early man” (Sulloway, p. 373). At the time of the 1915 edition of the *Three Essays*, Freud added the following passage: “The barrier against incest is probably among the historical acquisitions of mankind, and, like other moral taboos, has no doubt already become established in many persons by organic inheritance” (p. 225n).

With *Civilization and its Discontents*, he summed up thirty years of reflection on the question of the sexual etiology of neuroses, suggesting that the propensity of civilized man towards pathological repression should be imputed to prehistory in the following manner. Man was first an animal on four legs, responding to olfactory stimuli. When he adopted the vertical posture, visual stimuli came to replace olfactory stimuli. This giant step towards hominization led to feelings of shame (visible sexual organs), as well as disgust, linked to organic repression of the odors of excrement and of the genitals. Olfactive repression opened the way then to the evolution of civilization toward cleanliness and the first displacements, repressions, or sublimations, leading to the “organic” rejection of strong odors.

Freud completed the biogenetic scenario of the repression founding civilization with the hypothesis of the parricide that founded the human family, already advanced in *Totem and Taboo*. He linked this phylogenetic point of view to the diphasic development characteristic of human sexuality.

In 1930 Freud wrote one of the most comprehensive versions of his theory, expressing his conviction of the tight ties between sexuality, culture, and neurosis. Ontogenetically, neurosis was conceived as a particular malady, linked to a specific stage of libidinal fixation, to which the libido had to have regressed. The “hereditary” predisposition constituted a basic “scheme” for ontogenetic development, “provoking the fantastic rewriting of many infantile experiences, in conformity to the universal grill of phylogenesis” (1930a).

JEAN-FRANÇOIS RABAIN

See also: Eroticism, anal; Repression; Smell, sense of.

### Bibliography

- Freud, Sigmund. (1905d). Three essays on the theory of sexuality. *SE*, 7: 123–243.
- . (1909d). Notes upon a case of obsessional neurosis. *SE*, 10: 151–318.
- . (1930a). Civilization and its discontents. *SE*, 21: 57–145.
- . (1985c [1887–1904]). *The complete letters of Sigmund Freud to Wilhelm Fliess* (Jeffrey Masson, Ed. and Trans.). Cambridge, MA/London: Belknap Press.
- Laplanche, Jean. (1993). *Le fourvoisement biologisant de la sexualité chez Freud*. Paris: Les Empêcheurs de Penser en Rond.

Nunberg, Hermann and Federn, Ernst (Eds.). (1962–1975). *Minutes of the Vienna Psychoanalytic Society* (Volume 2: 1908–1910; M. Nunberg, Trans.). New York: International Universities Press.

Sulloway, Frank. (1979). *Freud—Biologist of the mind*. London: Burnett.

## ORGANIZATION

The concept of *organization* belongs in several different scientific fields. It is used just as frequently in biological discourse as in sociology or psychology. The notion of organization is usually associated with that of development. Neurobiology thus describes the nervous organization of human beings going from the simplest to the most complex structures, each integrated in the other.

Freud used the notion of organization and associated it with the development of the libido. He proposed that the sexual life of human beings does not develop in one phase but gradually, through a series of successive phases or organizations. He wrote in Lecture 21 of *Introductory Lectures on Psycho-Analysis* (1916–17a [1915–17]): “Normal sexuality has emerged out of something that was in existence before it, by weeding out certain features of that material as unserviceable and collecting together the rest in order to subordinate them to a new aim, that of reproduction” (p. 322). In the beginning infantile sexuality is characterized by relative anarchy and the absence of any real organization, with each of the component instincts striving independently of the others for satisfaction. The features of sexual organization take shape progressively, leading to a relatively stable libidinal structure, which is then replaced in the course of development with what we call normal adult sexuality. Particularly in *Three Essays on the Theory of Sexuality* (1905d), “The Disposition to Obsessional Neurosis” (1913i), and “The Infantile Genital Organization” (1923e), Freud described pregenital organizations and an adult genital organization. The first of the pregenital organizations leave it in the sadistic-anal organization, in which it is not the component genital tendencies that come to the fore but rather the sadistic and anal tendencies. From the point of view of psychopathology, obsessional neurosis represents a regressive form of this. On a more primitive level, and following Abraham’s work, Freud described another pregenital organization in which the erogenous zone of the mouth plays the main role, an organization that is

illustrated psychopathologically in the form of melancholy. In opposition to these infantile sexual organizations, genital organization is characterized by the fact that it is definitively constituted after puberty and all the component instincts are subordinated to the primacy of the genital organs and the goal of procreation.

Another line of development other than the erogenous zone must be taken into account in the constitution of libidinal organization: that of the relationship to the object. Freud did in fact describe this second line of development leading the little human being from an autoerotic phase (or organization) to a narcissistic phase and then to a phase of object discovery. Although they refer specifically to the psychoses in order to postulate the existence of a narcissistic organization, modern psychoanalytic studies, particularly those dealing with borderline and psychosomatic states, further enrich this notion by highlighting the defects in the constitution of primary narcissism and its object relations.

CLAUDE SMADJA

*See also:* Eroticism, anal; Eroticism, oral; Erotogenicity; Female sexuality; *Instincts and Their Vicissitudes*; Libidinal development; Libido; Melancholia; Ontogenesis; Orality; Partial drive; Preenatal; Psychosexual development; Stage (or phase).

### Bibliography

- Freud, Sigmund. (1905d). Three essays on the theory of sexuality. *SE*, 7: 123–243.
- . (1913i). The disposition to obsessional neurosis: A contribution to the problem of choice of neurosis. *SE*, 12: 311–326.
- . (1923e). The infantile genital organization (an interpolation into the theory of sexuality). *SE*, 19: 141–145.
- Green, André. (2001). *Life narcissism, death narcissism* (Andrew Weller, Trans.). London, New York: Free Association Books. (Original work published 1983)
- Smadja, Claude. (1999). Le fonctionnement opératoire dans la pratique psychosomatique: LVIIIe Congrès des psychanalystes de langue française des pays romans à Lausanne. *Revue française de psychanalyse*, 63 (6).

## ORGASM

Orgasm is the pleasure obtained at the culmination (end pleasure) of sexual activity; it differs from the preliminary pleasure of foreplay in that it corresponds to a relaxation rather than a rise in excitation. Freud takes up the commonly referred to link between orgasm and death (*petite mort*) by analogy with the separation between the soma and the germen and, in some of the lower animal species, the death of the male. From a metapsychological viewpoint the momentary short-circuiting of Eros through the satisfaction obtained ensures Thanatos a degree of supremacy.

The question of female orgasm and its dissimulation for reasons of cultural propriety is discussed by Freud in the first manuscripts addressed to Fliess (1950a [1897–1902]) and in the *Studies on Hysteria* (1895d), where he notes that, during orgasm, thought disappears almost completely and this restriction of consciousness is very similar to the hypnoid state, or even a hysterical crisis. Some years later, in the *Three Essays* (1905d), referring to the observations of the pediatrician Lindner, he notes that the sensations of the satiated infant can lead to a motor reaction similar to orgasm if it does not lead to sleep. He also acknowledges that the orgasm associated with genital emission is inaccessible to the infant, whose masturbatory activity is incomplete, a perspective he associates with the infant's endless quest for sexual knowledge (1910c). It is interesting that among Freud's last works this same idea reappears:

“The ultimate ground of all intellectual inhibitions and all inhibitions of work seems to be the inhibition of masturbation in childhood. But perhaps it goes deeper; perhaps it is not its inhibition by external influences but its unsatisfying nature in itself. There is always something lacking for complete discharge and satisfaction—*en attendant toujours quelque chose qui ne venait point* [always waiting for something which never came]—and this missing part, the reaction of orgasm, manifests itself in equivalents in other spheres, in absences, outbreaks of laughing, weeping [...], and perhaps other ways.—Once again infantile sexuality has fixed a model in this.” (1941f [1938], p. 300).

Freud didn't actually define orgasm as a psychic or affective phenomenon associated with, but somewhat

**ORGANOGENESIS.** *See* Psychogenesis/Organogenesis

distinct from, a somatic process, although he drew attention to its absence in discussions of the symptom of frigidity. Sándor Ferenczi (2000/1931), in describing masochistic orgasm, attempted to define normal orgasm as the “meeting of two tendencies to action. The love relationship apparently does not arise from subject A or from subject B but between the two of them.” This definition of a hypothetical “normality” does not go as far as his description of masochistic orgasm during female rape: “The reaction,” Ferenczi writes, “is primarily a shock, accompanied by the anxiety of death and disintegration, and only secondarily a plastic identification with the emotion of the sadist, a hallucinatory masculine identification” (p. 248).

The function of the orgasm played a central role in the work of Wilhelm Reich (1940/1968), illustrating that it is necessary to incorporate an “actual” neurosis into any psychoneurosis. Reich took up Freud’s propositions concerning libidinal stasis and its conversion into anxiety. He defined “orgiastic power” as “the aptitude to achieve satisfaction matching the libidinal stasis of the moment.” Moreover, according to Reich, while inhibition prevents the transference of sexual excitation to the sensorimotor system and the genital apparatus, the excitation remains compressed within the vasovagal system and produces the phenomena of vasomotor neurosis. Reich believed, however, that civilization and monogamous marriage do not allow orgasm to develop and fulfill its function. There is not only a biological perspective in Reich’s work (bioenergy, orgone), but a moral and political vision as well: “The patient, previously moralistic in his ideology and perverse, lascivious and neurotic in reality, becomes free of this contradiction in himself; with his moralism he also loses his sexual anti-sociality and acquires a natural morality in the sex-economic sense” (1933/1946, p. 156).

SOPHIE DE MIJOLLA-MELLOR

See also: Adolescence; Anorexia nervosa; Dipsomania; Orgone; Partial drive; Perversion; Reich, Wilhelm.

### Bibliography

Ferenczi, Sándor. (2000). On masochistic orgasm. In *Final contributions to the problems and methods of psychoanalysis*. (p. 248–49; Michael Balint, Ed; Eric Mosbacher, Trans.). London: Karnac Books. (Original work published 1931)

Freud, Sigmund. (1905d). Three essays on the theory of sexuality. *SE*, 7: 123–243.

———. (1941f [1938]). Findings, ideas, problems. *SE*, 23: 299–300.

Reich, Wilhelm. (1946). *The mass psychology of fascism* (T. P. Wolfe, Trans.). New York: Orgone Institute Press. (Original work published 1933)

———. (1968). *The function of the orgasm: Sex-economic problems of biological energy* (Theodore P. Wolfe, Trans.). London: Panther. (Original work published 1940)

### Further Reading

Abraham, G. (2002). The psychodynamics of orgasm. *International Journal of Psychoanalysis*, 83, 325–338.

Eissler, Kurt R. (1977). Comments on penis envy and orgasm in women. *Psychoanalytic Study of the Child*, 32, 29–84.

## ORGONE

The term *orgone energy* was coined by Wilhelm Reich to designate what he hypothesized to be the fundamental energy of a biological nature omnipresent in the cosmos. In addition to sounding scientific, the term *orgone* derived from Reich’s views concerning orgasm, a pivotal concept in his theory of “sex economy.” In the summer of 1939, while performing “bioelectrical” experiments, Reich believed that he isolated energy-filled microscopic vesicles that he called *bions*. He went on to formulate a specific hypothesis that “organismic orgone energy” is a vital, irreducible form of energy that manifests itself with special intensity in sexual activity. Reich came to believe that orgone energy is also present in etheric form in the atmosphere and active in certain kinds of precipitation such as storms and tornadoes; he believed it exists throughout the cosmos and played a role in formation of the universe. Reich’s later writings are entirely taken up with aspects of *orgonomy*, as he called his theory and teachings. Clinically, he invented *orgone therapy*; he called the research institute that he established in Maine (the present day Wilhelm Reich Museum) the *Orgonon*. Reich also defined an egglike geometric form as the *orgonome*, which he viewed as a basic biological shape. To capture atmospheric orgone and put it to clinical use, Reich built box-like devices he called *orgone accumulators*. His therapeutic claims for these led to an injunction by the Food and Drug

Administration (FDA) in 1954. This resulted in a contempt citation that brought about Reich's imprisonment in Lewisburg Federal Penitentiary, where he died three years later. In a famous act of censorship, the FDA ordered certain of Reich's pamphlets and publications concerning orgone energy to be banned and destroyed.

ROGER DADOUN

*See also:* *Character Analysis*; Character formation; Orgasm; Reich, Wilhelm.

### **Bibliography**

Dadoun, Roger. (1975). *Cent fleurs pour Wilhelm Reich*. Paris: Payot.

Reich, Wilhelm. (1948). *The cancer biopathy*. New York: Orgone Institute Press.

———. (1967). *Reich speaks of Freud* (Mary Higgins and Chester M. Raphael, Eds.; therese Pol, Trans.). New York: Farrar, Straus.

Sharaf, Myron. (1983). *Fury on earth: A biography of Wilhelm Reich*. New York: St. Martin's.

---

### **ORNICAR?**

The journal *Ornicar?* was founded in January 1975 by Jacques-Alain Miller, Jacques Lacan's son-in-law. Subtitled *Bulletin périodique du champ Freudien* (Journal of the Freudian field), *Ornicar?* "was both the home and the organ of the Young Turks" (Miller, 1984). Lacan supported it against the opposition of the elder members of the École Freudienne de Paris (Freudian School of Paris). *Ornicar?* is also the journal of the Department of the Freudian Field at the University of Vincennes, which was founded by Serge Leclair in 1968 and was led and directed by Lacan and Miller from 1970.

From the start, Miller, who was entrusted with the transcription of Lacan's seminar, used *Ornicar?* as a venue for publishing seminar sessions. Published seminars include *R.S.I.* (The real, the symbolic, and the imaginary; 1974–1975) in nos. 2–5; *Le Sinthome* (The symptom; 1975–1976) in nos. 6–11; *L'une-bévue* (A blunder; 1976–1977) in nos. 12–18; and the final seminar, *Dissolution* (1980) in nos. 20–23. With the publication in no. 9 of a talk that Lacan delivered on January 5, 1977, "The Inauguration of the Clinical Program," *Ornicar?* became a

vehicle for elaborating Lacan's clinical technique, which was developed and taught outside of the École Freudienne at Vincennes.

From January 1975 to June 1989, twenty-eight issues of *Ornicar?* were published under Miller's editorship. Simultaneously, sixty-three issues of *Analytica*, a research journal for Freudian studies, were also published. These issues included reprints of psychiatric classics and essays on contemporary clinical practice.

After Lacan's death in 1981, Miller began to publish some of Lacan's unpublished writings in *Ornicar?* (nos. 24–25), starting with the seven lectures on *Hamlet* from seminar 6, *Le désir et son interprétation* (Desire and its interpretation).

Laurence Bataille, the daughter of Sylvia Lacan and Georges Bataille and the stepdaughter of Lacan, acted as director of the publication from 1976 to 1978 and helped to edit the journal before eventually withdrawing.

In 1998, starting with no. 49, the journal got a new lease on life under the direction of Miller.

JACQUES SÉDAT

*See also:* École Freudienne de Paris (Freudian school of Paris); France.

### **Bibliography**

Miller, Jacques-Alain. (1984). Editorial. *Ornicar?* 28.

---

### **OSSIPOV, NIKOLAI LEGRAFOVITCH (1877–1934)**

Nikolai Ossipov, a Russian physician and dean of Moscow University and Charles University of Prague, was born on October 12, 1877, in Moscow and died in Prague on February 19, 1934.

The only son of a respected physician, he was brought up in a very cultured family. In 1897 he graduated summa cum laude from the best lycée in Moscow and immediately enrolled in the medical faculty of Moscow University. In 1899 he was suspected of taking part in a student brawl, imprisoned, and expelled from university. He then went abroad to continue his studies in Germany and Switzerland. He presented his doctoral thesis in histology before Kaufmann in Basel and graduated as a physician on November 16, 1904.

That same year he returned to Moscow and worked in the university histology department, as well as in the municipal psychiatric hospital (*Preobechensk*). In 1906 he followed Vladimir Serbski to the Moscow University psychiatric clinic and definitively abandoned histology.

In 1907 Ossipov began to study Freud's work and spent some time with Jung. In his *Mémoires* he describes himself as the first to popularize Freud in Russia and he was the founder of Russian psychoanalytic terminology. His first work in the discipline (1908) consisted of inventories of Freud's previously published works. His first personal publication dates from 1910, the year when he visited Freud in Vienna and founded the collection "The Psychotherapeutic Library." He was also the cofounder of a psychotherapeutic outpatient unit in the University Clinic in which psychoanalytic techniques were applied without restriction. In 1911 he was elected president of the Moscow Psychoanalytic Society. In the same year Ossipov, Serbski, and most of their colleagues left the university in protest against restrictions on autonomy decreed by Kasso, the Minister for Education. Ossipov then set up in private practice. In 1912, a psychoanalytically-informed seminar was organized under the name of "little Fridays," with Serbski as president and Ossipov acting as secretary during the sessions.

After the Bolshevik Revolution of 1917 he fled his beloved Moscow, lived in Southern Russia and, in 1921, continued his flight via Istanbul to Prague. His scientific and teaching skills were recognized in Czechoslovakia. In 1922 he was offered a post as professor of psychiatry in Masaryk University at Brno. The ever-conscientious and modest Ossipov declined to accept the position, claiming an insufficient knowledge of the language and socio-cultural conditions of the country. He did, however, accept a position as director of the psychiatric outpatient clinic at Charles University and lectured there on psychoanalysis.

He privately built up a stable work group consisting of émigré Russian students and physicians whom he trained in psychiatry and psychoanalysis. Ossipov always maintained good relations with the Prague psychoanalytic group and in 1931 he and Emmanuel Windholz took the initiative of placing a commemorative plaque, in honor of Freud's seventy-fifth birthday, on the house where he was born in Píbor (Freiberg). For reasons of ill health neither Ossipov nor Freud could personally attend the inauguration, which took

place on October 25, 1931. Ossipov was suffering from myocarditis, from which he died in 1934. He was given a solemn burial in the Russian cemetery in Prague.

The author of articles on "Tolstoy's Childhood Memories" (1923) and "Revolution and Dreams" (1931), in the course of his exile Ossipov was published in the *Internationale Zeitschrift für Psychoanalyse* and other journals. He corresponded with Freud until his death. As a central figure in the development of psychoanalysis in Russia, he played an active role in having Freud's work published there. Through his actions he also had an influence on the development of the psychoanalytic movement in Czechoslovakia, where his student, Theodor Dosuzkov, managed to keep psychoanalysis alive under both the Nazi and the Communist régimes.

EUGENIE FISCHER AND RENÉ FISCHER

See also: *Psychoterapia (Psixoterapija-Obozrenie voprosov lecenija i prikladnoj psixologii)*; Russia/USSR.

### Bibliography

Ossipov, Nikolai Jegrafovitch. (1908). Psychologische und psychopathologische Einsichten S. Freuds in der deutschen Literatur bis 1907. *Zeitschrift für Neuropathologie und Psychiatrie S.S. Korsakowa*, 564–584.

———. (1912). Das zwanghafte Lächeln. *Zeitschrift für Neuropathologie und Psychiatrie S.S. Korsakowa*, 4, 3–11.

———. (1923). Tolstois Kindheitserinnerungen. *Imago*, 2, 1–171.

———. (1931). Revolution und Traum. *Wissenschaftliche Arbeit der russischen Universität in Prag*, 4, 175–203.

## OTHER, THE

The notion of "the Other" was developed by Jacques Lacan in particular (*Écrits*, pp. 9, 16, 55–56, 379, 431, 575, 690, 751, 807, 852).

Yet, properly speaking, the Other is not a Freudian concept, even if it seems central to the experience of treatment.

Situating the dream and the unconscious in "another scene" was as far as Freud went in conceptualizing this place. The Topographical theory (conscious—preconscious—unconscious) like the structural theory (id—ego—superego) does not allow for the radical otherness of the unconscious, because it

situates its terms on the same level. But the unconscious is what forces us to think three-dimensionally despite the dualities that define the imaginary.

The Lacanian Other does not have a philosophical origin either. Platonic otherness (cf. *Timaeus*) is reserved for what temporarily disrupts sameness, considered as ideal. Of course, the difference between the sexes is in all likelihood the imaginary basis for Plato's thought. But homosexual influence, which generally underlies his thought, continues to treat woman as a degraded man, that is, identical except for a single detail, but at the price of investing this detail narcissistically.

The Other dimension introduced by Freud and conceptualized by Lacan is all the same an essential contribution to the conduct of treatment, as well as to the cultural field.

How can a reader grasp a category that, without being magical or supernatural, cannot be touched or seen? Perhaps by appealing to the shared experience of speech, insofar as it always supposes an interlocutor—it is said that a child learns not so much to speak as to respond, in such a way that the original address remains the force behind his words. Dialogue both unites and divides speaker and listener through what they are unaware of and what motivates them, the unconscious. This reciprocal opening is just what is needed if each is going to seek in the other the object, the unknown cause of his own desire, without which each one sings his or her own song, and no harmony results.

This other place, which is circumscribed by the opening proper to the "speaking-being," (who engages the lost object, the great sustainer of desire, through the operation that Freud called castration) and which overlaps with that of the partner, is the gap, covered or sutured, that shelters the unconscious.

The Other as a concept refers to the heterogeneity of this place, as that from which a speaker's own speech comes back to him or her; when that happens, the speaker discovers that he is a subject. But it is also the place to which the speaker talks back, since it conceals the object that concerns him or her most intimately. Our two interlocutors, assumed to exist in the same space, are thus revealed as radically heterogeneous. No longer does any supposed detail differentiate them. Rather the place that they occupy, the one coming to the locus of the Other to represent the lost object (object *a*, according to Lacan) ignites desire.

Coming thus from the Other, the address made to the subject comes to him by the intermediary of the little other that supports desire. But just because it is reduced to being represented by either the gap or the eclipse (Lacan writes that the all of Euclidian space is supported by the gap that it veils), the Other place is not for all that a dark continent. It comes to the infant by his mother's speech. Later the infant will have to abstract from that speech the laws of language. This necessary ordering—shown by Ferdinand de Saussure to be organized by signifiers that each refer to another signifier rather than to some object—introduces the child to the dimension of loss.

This loss becomes evident when the speaker receives from this place a message that expresses a desire. When a slip of the tongue makes it too explicit, he feels shame. Neurosis is the I's refusal to adapt to, or endorse, this desire coming from the Other, which the subject might experience as pathological or foreign (in obsession) or intrusive (in hysteria).

This Other place, as an unimpeachable third party, is the only thing that makes it possible for two speakers to avoid a fatal, mirror-image confrontation, in which it is the word of one against the other. Not only the place of lack, the Other is also the place of truth insofar as it allows our ideas, however vain, the dignity of representing the truth.

We live in a time when the remarkable progress of science tends to foreclose any such otherness, its defining importance for human experience notwithstanding. The unmediated duality that science promotes is discernible even in the success of economic liberalism, even in the elevation of the idea of direct democracy. The very face of power is obliged to display itself as a mirror image, familiar and without mystery; while powerful popular tendencies push for the homogenization of human groups. It will be the better for us if analysis can prevent us from underestimating the risks.

CHARLES MELMAN

*See also:* Alienation; Alterity; Althusser, Louis; Castration of the subject; Demand; Four discourses; Fantasy, formula of; Foreclosure; Graph of Desire; Imaginary identification/symbolic identification; Imaginary, the (Lacan); Jouissance (Lacan); Matheme; Mirror stage; Object *a*; Phallus; Splitting of the subject; Optical schema; L and R schema; Seminar (Lacanian); Subject; Subject of the unconscious; Subject's desire; Symbolic, the (Lacan); Unary trait.



### Bibliography

- Lacan, Jacques. (1966). *Écrits*. Paris: Seuil.
- . (2002). *Écrits: A Selection*. (Bruce Fink, Trans.). New York: W. W. Norton.

### Further Reading

- Berman, E. (2002). Identifying with the other, a conflictual vital necessity. *Psychoanalytic Dialogues*, 12, 141–152.
- Laplanche, Jean. (1997). The theory of seduction and the problem of the other. *International Journal of Psychoanalysis*, 78, 653–666.

---

## OTHERNESS

Otherness (alterity) is a logical and metaphysical concept of considerable generality that would not ordinarily be included in a dictionary of psychoanalysis if, together with the concepts of the Big Other and the small other, Jacques Lacan had not taken Freud's ideas as far as he did and if contemporary French psychoanalysis had not been so enamored of the philosophical and moral system proposed by Emmanuel Levinas. In Plato's *Sophist*, the "other" is one of the first five kinds (along with existence, rest, motion, and sameness). For Hegel, to the extent that the first moment of every being-there contains its own negation, alterity can be considered as the engine of dialectical movement. In a different register, the Christian tradition, reformulated by Kant, conceives the categorical imperative of morality as the commandment that requires us to treat others not simply as means but as ends. We can also consider the concept of alterity as one of the foundations of ethics. But there is little sign of Freud in this, and we would be assigning psychoanalysis a task of considerable ambition if we were to look within it for the solution to these philosophical and moral problems.

Nonetheless, the concept is not completely foreign to either Freud or psychoanalysis, and there are certainly signs of its presence there, although indirect. Although Freud's work supplies no formula for moral relations with the other, the question of the essence of human relationship is treated explicitly in *Group Psychology and the Analysis of the Ego* (1921). Here, Freud discusses the theories of Gustave Le Bon and, more generally, the notion of this relationship as the result of a kind of "sympathy." For him all relations among humans involve the image of the father. Humankind,

Freud says, is not a gregarious animal (*Herdentier*) but a horde animal (*Hordentier*). He therefore transposes into the real world the schema found in *Totem and Taboo*, according to which the (Darwinian) primitive horde is a society in which the only bonds consist of a shared dependence on the primitive father. Thus Freud rediscovers, probably without realizing it, Leibniz's vision of monads that can only communicate with one another through God. Prime examples of this would be, according to Freud, the Church and the Army, to the extent that their unity lies in the relation of each of their members to a leader (Christ, the general). But we find the same thing in more banal situations (for example, the collective body of all the young girls in love with the same singer), where the interhuman bond is not sympathy but a more or less sublimated form of jealousy. However, this is a psychosociological theory of interhuman relations and not a moral conception of the relation to the other.

That being said, there is a great temptation among authors inspired by Freud to try to develop from his work a "psychoanalytic" theory of the "true" relationship to the other and to assume that the psychoanalyst will lead the patient toward a genuine recognition of the other, for example, by overcoming his narcissism. Obviously, this exceeds the content and claims and to some extent even the spirit of Freud's work. Whenever Freud appears to move in this direction, he always manages to qualify his position. For example, in *Three Essays on the Theory of Sexuality* (1905d), he states that during puberty, when the sexual drive is subordinated to the reproductive function and the adolescent begins to love another human being, this drive "becomes, so to say, altruistic" (p. 207). But the expression "so to say" (*sozusagen*) clearly indicates that he is not referring to any kind of moral altruism.

Naturally, the concept of the "other" being extremely common, some, relatively obscure, Freudian texts have managed to give rise to farfetched speculation, although there is no shortage of interest in them. For example, there is an enigmatic passage in *The Ego and the Id* (1923b) in which Freud, criticizing the notion of "unconscious sensation," evokes "a quantitative and qualitative 'something' in the course of mental events" (p. 22) and emphasizes the originality of the notion of the "id" that he is in the process of borrowing from Groddeck.

Somewhat more picturesque is the role accorded by Freud to a play by the Austrian dramatist Hermann

Bahr, presented for the first time in Vienna on November 25, 1905, and whose title is *The Other* (the title is feminine in German, *Die Andere*). Freud’s comment appears in an article entitled “Psychopathic Characters on the Stage” (1942a [1905–06]). After describing the conditions needed to make a neurotic or psychotic the hero of a drama, Freud states, rather curiously, that these conditions are fulfilled in *Hamlet* but not in the play by Bahr, where the young violinist Lida Lind goes mad between the first and fifth acts. Yet, independently of this peremptory judgment on the heroine’s choice, we are struck by a kind of “play of alterity.” For we may suspect—and the author invites the spectator to believe this—that Lida’s madness arises from her dependence on her first lover, Amschl, who would then be the seducing other (*der Andere*, which is masculine). But it gradually becomes clear that she is the victim of the fact that she herself was, in the past, in love with a personality from whom she was unable to detach herself, the feminine other. Of course, in his remarks, Freud does not comment on this aspect of the play. But one wonders if he did not initiate a train of thought that might have led him to develop certain aspects of alterity that would have become, although not explicitly, a genuine psychoanalytic concept.

YVON BRÈS

*See also:* Alienation; Autism; Certeau, Michel de; Double, the; Narcissism; Object; Other; Philosophy and psychoanalysis; Transcultural.

### **Bibliography**

- Bahr, Hermann. (1906). *Die Andere*. Frankfurt am Main: S. Fischer.
- Freud, Sigmund. (1905). Three essays on the theory of sexuality. *SE*, 7: 125–245.
- . (1921). Group psychology and the analysis of the ego. *SE*, 18: 69–143.
- . (1942 [1905–06]). Psychopathic characters on the stage. *SE*, 7: 305–310.
- Levinas, Emmanuel. (2000). *Alterity and transcendence*. (Michael B. Smith, Trans.). New York: Columbia University Press. (Original work published 1995)

### **“OUTLINE OF PSYCHOANALYSIS, AN”**

“An Outline of Psychoanalysis” was never completed. Freud, returning to an earlier project of providing an

overview of psychoanalysis, began writing it in Vienna in 1938 as he was waiting to leave for London. By September 1938 he had written three-quarters of the book, which was published in 1940, a year after his death.

Composed of three sections, the “Outline” opens with a description of the psychic apparatus, including its spatial organization and differentiation into agencies. The ego, which develops through contact with the outside world, attempts to reconcile the needs of the id, the superego, and reality. The id represents the hereditary past, the superego, tradition. Drives, which are basically conservative and located in the id, represent somatic needs for the psyche. Eros and the destruction, or death, impulse, whether antagonists or combined in biological functions, are the two fundamental impulses.

The libido is the energy of Eros. The libido of the ego is characterized by its narcissistic mobility toward objects. The sexual function, whose somatic sources are the erogenous zones, undergoes a two-phase development process, including a latency phase. The infantile period, which is later forgotten (infantile amnesia), is characterized by the succession of the oral, sadistic-anal, and phallic phases in both sexes. A genital phase of instinctual integration completes sexual organization at puberty. The realization of normality depends on quantitative factors.

Psychic processes can have three qualities: conscious, preconscious, or unconscious. The first two are related to the ego, the last to the id. The ego receives perceptions whose origins—external or internal—it distinguishes by testing them against reality. The id is formed of primitive and repressed contents. The difference in psychic qualities is primarily a function of the laws of energy that govern the processes: primary, with free energy in the case of the id, secondary, with bound energy in the case of the ego. A sleep impulse drives the ego to return to the life of the womb, with a weakening of the anti-cathexis of the ego; studying dreams can help us understand the laws of the primary process.

Analysis assumes an alliance between the “fundamental rule” of the analysand and knowledge and discretion on the part of the analyst. Transfer, the true driving force behind analysis, can help in a “post-educational” process. The strengthening of the ego is combined with the difficult work of removing various forms of resistance, with those arising from the defusion of impulses being the most difficult to resolve.

Neurosis, which has no specific causes, is associated with the traumatic effects of early infancy and education on an ego that is not fully formed, the two-phase nature of human sexuality, and partially repressed impulses. The first object is the mother, the “first seductress,” the prototype of all subsequent love relationships. The Oedipus complex and the castration complex are organized differently depending on sex, with fantasies helping to perpetuate bisexual conflicts and identification (psychic bisexuality). Unlike the id, the ego, in contact with the outside world, understands the reality principle and self-preservation by signaling our anxiety. The child with an immature ego represses its sexuality and the Oedipal complex out of fear of losing the love of its parents, who provide its security. Even during psychosis, a part of the psychic apparatus can maintain a normal relationship with reality, reflecting a split in the ego. This split, which arises from a denial of perception, is observed in the fetishist or during development when the growing child is faced with the requirements of reality.

In neurosis, the habitual conflict is distinct, from a topographical point of view, pitting the ego and the id against one another. After the age of five, we see the emergence of the superego, the heir to the Oedipus complex, resulting from the child’s identification with the parents. An intermediary between the ego and id, the superego represents the past of the child’s civilization, an exterior world that is converted into an internalized past.

For Freud the “Outline” introduced no new insights, an opinion shared by Ernest Jones. The text illustrates Freud’s constant reference to an economic point of view, with an emphasis on quantitative factors. It focuses on an examination of the ego and deepens his understanding of splitting. Eros, the agent of union, reunites sexuality and love, and the object is here given a predominant place.

CHRISTIAN SEULIN

### Source Citation

Freud, Sigmund. (1940a [1938]). “Abriss der Psychoanalyse,” *Internat. Zschr. Psychoanal. Imago*, 25, pp. 7–67; G.W., XVII, 63–138; An outline of psychoanalysis. SE 23: 139–207.

### Bibliography

- Jones, Ernest. (1953–1957). *Sigmund Freud: Life and work*. London: Hogarth Press.
- Nunberg, Hermann. (1950). A commentary on Freud’s “An Outline of Psychoanalysis,” *Psychoanalytic Quarterly*, 19 (2), 227–250.

---

## OVERDETERMINATION

The idea of overdetermination refers to the organization of multiple determinants combining to define a psychic formation. The notion may be represented metaphorically as multiple nodes anchoring a web whose linking strands are lines of associated thoughts. The content of psychic formations understood in this way is determined by the points of intersection of the lines of association, along which psychic energy flows as part of a process of displacement.

Another Freudian conceptualization of overdetermination, lateral and etiopathogenic, views psychic formations as the outcome of a cumulation of causes whose combination is the necessary condition of their coming into being.

Freud introduced the concept of overdetermination very early on: it is sketched out in the *Studies on Hysteria* (1895d), though more in the etiopathogenic sense of a constitution of the subject rendering him vulnerable to a traumatic accumulation of factors than in the sense of chains of association. The latter sense emerged more clearly, indeed in its definitive form, in *The Interpretation of Dreams* (1900a), where the elements of the dream-content, viewed as nodes, are described as overdetermined in that they are represented many times over in the dream-thoughts, which crystallize at these points. Overdetermination thus came to be seen as the basis of dream-formation, and Freud focused the remainder of his study on the mechanisms that facilitated it. Thus in analyzing the dream of “Irma’s injection,” he isolated the mechanism of condensation, and in particular developed the idea of “collective figures.” And since overdetermination suggested a procedure for selecting the components of the dream-content, he proposed the notion of the displacement of psychical intensity along associative chains and ramifications. Displacement and condensation, he argued, were the foundation of dream-formation.

Overdetermination was seen by Freud as affecting the symptom as well as the dream; in the wake of

Jacques Lacan it is applied more broadly to all formations of the unconscious. It should not be taken, however, as a principle of very wide extension, but simply as the basis of that fluctuation of associations which makes different interpretations of the same psychic formation possible.

MATHIEU ZANNOTTI

*See also:* Condensation; Look/gaze; Overinterpretation; Paranoia; *Psychopathology of Everyday Life, The*; Rite and ritual; Science and psychoanalysis; Strata/stratification; *Studies on Hysteria*; Sum of excitation; Symbolic, the (Lacan); Symbolism.

### **Bibliography**

Freud, Sigmund. (1900a). The interpretation of dreams. *SE*, 4–5.

Freud, Sigmund, and Breuer, Josef. (1895d). Studies on hysteria. *SE*, 2: 48–106.

## **OVER-INTERPRETATION**

*Over-interpretation* is the possibility, envisaged by Freud (1900a), that the psychoanalyst may encounter an increase in material and produce a new interpretation very close to the patient's unconscious fantasy. Over-interpretation can result from the patient's freely associating on the basis of his dream, thereby increasing the material subject to interpretation. More generally, over-interpretation involves giving an interpretation that is not limited to clarification but comes close to the unconscious fantasies that structure the material. Fantasies not only occur in dreams, to be extracted by interpretation; they predetermine how dreams are interpreted. Over-interpretation allows these fantasies to be dynamically revived.

In chapter 7 of *The Interpretation of Dreams* (1900a), where *over-interpretation* appeared for the first time, Freud employed it as a way of warning the novice analyst that his work is not finished when he arrived at what he believes to be a complete and coherent interpretation of the dream: "For the same dream may perhaps have another interpretation as well, an 'over-interpretation,' which has escaped him. It is, indeed, not easy to form any conception of the abundance of the unconscious trains of thought, all striving to find expression, which are active in our minds. Nor is it easy to credit the skill shown by the dream-work

in always hitting upon forms of expression that can bear several meanings—like the little tailor in the fairy story who hits seven flies at a blow" (p. 523).

The possibility of over-interpretation is thus directly linked to the overdetermination of unconscious formations and the interdependence of mental contents, which this overdetermination presupposes. Unconscious formations do, of course, result from different causes (such as symptoms and fantasies), but in each case they are connected to multiple unconscious elements. In this sense, over-interpretation is the repeated attempt to stay as close as possible to sexual and infantile contents. Yet over-interpretation also points directly toward what Freud designated as the main stumbling-block for interpretive work on dreams, the umbilical navel of the dream: "There is often a passage in even the most thoroughly interpreted dream which has to be left obscure; this is because we become aware during the work of interpretation that at this point there is a tangle of dream-thoughts which cannot be unravelled and which moreover adds nothing to our knowledge of the content of the dream. This is the dream's navel, the spot where it reaches down into the unknown" (1900a, p. 525).

The notion of over-interpretation thus allowed Freud to show that there is no such thing as a true or false interpretation that could be related to a realist conception of meaning. On this subject Pierre-Henri Castel has remarked, "It is thus never one single meaning that is really present to the mind, and can be given a true or false interpretation: rather, it is always a partially realized set of meanings that can be given a true or false interpretation only if this interpretation takes into account their potential interrelations" (1998).

More generally, the notion of over-interpretation, by making an open, dynamic conception of interpretation possible, raises the question of origins. Fantasies of origin create and determine the formations of the unconscious in general and of the dream in particular.

DELPHINE SCHILTON

*See also:* Interpretation; Overdetermination.

### **Bibliography**

Castel, Pierre-Henri. (1998). *Introduction à "L'interprétation du Rêve" de Freud*. Paris: Presses Universitaires de France.

Freud, Sigmund. (1900a). The interpretation of dreams. *SE*, 4: 1–338; 5: 339–625.



# P b

## PAIN

The term “pain” refers to a physical sensation or a distress linked to instinctual tension, which the psychic apparatus then seeks to discharge by work according to the principle of pleasure/unpleasure.

Jean-Bertrand Pontalis (1981) noted that the outline for an original theory of pain can be found in Freud’s work from “A Project for a Scientific Psychology” (1950c [1895]) onward. Taken up again in *Inhibitions, Symptoms, and Anxiety* (1926d [1925]), this theory covers the basic reference points of analytic theory: the theory of narcissism, the question of trauma, the definition of primary masochism, and the presentation of the death instinct. Finally, with the concept of negative therapeutic reaction in place, Freud, in *The Ego and the Id* (1923b), described how pain drives resistance to analysis, indeed, how pain is the final refuge from renouncing the lost object, as the resistance implies.

By 1895 Freud had postulated bipolarity as the principle of psychic functioning, and, anticipating his later theory of instinctual dualism, he opposed the experience of pain to the experience of satisfaction. In qualitative terms, pain is different from unpleasure in that pain is situated outside the economic apparatus of pleasure/unpleasure. In dynamic terms, “[p]ain is . . . characterized as an irruption of excessively large Qs [quantities] into N [neurones that don’t retain quantities of energy] and R [neurones that do retain energy and are capable of retaining memory]” (1950c, p. 307). Then the body discharges the accumulated excitation. Pain can cause the subject to break out of preestablished paths only because there are boundaries (bodily boundaries, ego boundaries); however, its internal discharge has an implosive effect. Like a physical or psychic hole

(to be distinguished from a possible lacuna or a lack), the excess of excitation caused by pain obstructs all binding activity. Pontalis (1981) has stressed that this theory of pain breaching is a departure from the economic apparatus where the theory of anxiety is more generally situated.

In 1926, in addendum C to *Inhibitions, Symptoms and Anxiety*, Freud again tried to differentiate pain from anxiety, though not without difficulty or contradiction. Pain is primarily a reaction to the loss of the object, whereas anxiety is a reaction to the danger that loss entails. Pain is the consequence of a breaching of the protective shield, and by acting as a constant instinctual excitation (some authors have proposed the idea of a pseudo-instinct here), it prevents the subject from escaping from it. Nonetheless, pain has a locus: it emanates from the periphery of the body or the organs. If anxiety has already led the subject to regard the loss of the object metaphorically, the unmediated reality of pain ensures that the subject can survive without the loss of the object or the nostalgia of that loss. In a third stage of his exposition in addendum C, Freud returns to the difference between mental pain and physical pain, arguing that the former is much more closely related to the mechanism of anxiety. “The transition from physical pain to mental pain corresponds to a change from narcissistic cathexis to object-cathexis. An object-presentation which is highly cathected by instinctual need plays the same role as a part of the body which is cathected by an increase of stimulus” (1926d, pp. 171–172).

Freud thus uses the same model to describe both physical pain and psychic pain. As Pontalis has made clear, pain is not a case of metaphor but rather a case of analogy—a direct exchange between one level and

another, as if with pain the body mutates into psyche and the psyche into body. But while anxiety can be communicated, pain cannot. Despite a scream of pain, the cry does nothing to ease it. The experience of pain takes place within a bodily ego. Both physical pain and mental pain partake of the content-container relationship (Enriquez, 1980; McDougall, 1978). The subject in pain finds it impossible to recover the object by means of representation: "Where there is pain, it is the lost, absent object that is present; the real, present object that is absent." The distinctive feature of pain is its blurring of boundaries. Thus, for example, certain types of physical suffering serve to alleviate mental pain. Recent clinical work on somatization and borderline states is often faced with this inchoate nature of pain: absolute, naked pain.

DRINA CANDILIS-HUISMAN

*See also:* Cathexis; Dead mother complex; Elisabeth von R. case of; Erotogenic masochism; Guilt, unconscious sense of; *Inhibitions, Symptoms, and Anxiety*; Masochism; Melancholia; Mourning; Physical pain/psychic pain; Pleasure/unpleasure principle; Protective shield, breaking through the; Psychosomatic limit/boundary; "Project for a Scientific Psychology, A"; Quota of affect; Sadism; Sado-masochism; Self-mutilation in children; Suffering; Unpleasure.

### **Bibliography**

- Enriquez, Micheline. (1980). Du corps de souffrance au corps en souffrance. *Topique*, 26, 5–27.
- Freud, Sigmund. (1923b). The ego and the id. *SE*, 19: 1–66.
- . (1926d [1925]). Inhibitions, symptoms, and anxiety. *SE*, 20: 75–172.
- . (1950c [1895]). A project for a scientific psychology. *SE*, 1: 281–387.
- McDougall, Joyce. (1978). *Plaidoyer pour une certaine anormalité*. Paris: Gallimard.
- Pontalis, Jean-Bertrand. (1981). *Frontiers in psychoanalysis: Between the dream and psychic pain* (Catherine Cullen and Philip Cullen, Trans.). London: Hogarth Press and the Institute of Psycho-Analysis. (Original work published 1977)

---

## **PAIRS OF OPPOSITES**

Freud uses the term "pairs of opposites" to designate the pairing of two apparently contradictory terms and, beyond this, the two psychic phenomena to which

these terms refer. Freud refers to the idea in his correspondence with Wilhelm Fliess, to whom he writes on March 2, 1899, "I can hardly wait for Easter to show you in detail a principal part of the story of wish fulfillment and of the coupling of opposites" (1985c [1887–1904]). Curiously, despite Freud's alleged impatience, there is no further sign of this elaboration, at least in the published correspondence, where Freud restricts himself to setting out the uncertainties and contradictions that he is experiencing in relation to his work.

Freud thus restricts himself, inadvertently perhaps, to working out the essence of what he understands by the pairing of opposites, as he clearly states in *Three Essays on the Theory of Sexuality* (1905d): "Certain among the impulses to perversion occur regularly as pairs of opposites" (p. 160). He then refers to the pairs sadism/masochism and masculine/feminine, also mentioning activity/passivity in an addition in 1915. In the same text he emphasizes, "An especially prominent part is played . . . by the component instincts, which emerge for the most part as pairs of opposites: . . . the scopophilic instinct [the gaze] and exhibitionism and the active and passive forms of the instinct for cruelty" (p. 166).

The vagaries of the transference highlight these oppositions. Often the negative transference is found "side by side with the affectionate transference, often directed simultaneously towards the same person. Bleuler has coined the excellent term 'ambivalence' to describe this phenomenon" (Freud, 1912b, p. 106).

Freud returned to the sadism/masochism pair in a note added in 1924 to the text of *Three Essays on the Theory of Sexuality*. There he wrote that his recent observation, as outlined in "The Economic Problem of Masochism" (1924c), led him "to assign a peculiar position, based upon the origin of the instincts, to the pair of opposites constituted by sadism and masochism" (1905d, p. 159n). This derives directly from the structure of the second theory of drives, in which the life instinct and death instinct form a pair of opposites that directs all the other drives.

The concept of pairs of opposites, which might seem narrowly descriptive, in fact involves some fundamental aspects of metapsychology. Specifically, this concept relates to the conflict at the core of the processes of the psyche, with its drives and ambivalences.

The dualistic nature of Freud's thought, which he adduced to explain and pair apparently contradictory

terms and concepts, has often been emphasized. Yet this Freudian dialectic has nothing to do with the dialectic of classical Aristotelian logic or of modern Hegelian philosophy. When Freud indicates a contradiction, he seeks to demonstrate the underlying conflict generating it. The contradiction itself is but a secondary transposition at the level of conscious thought. Hence, Freud's solution to contradiction is not Hegelian transcendence, but a dynamic and economic process of psychic transcendence.

ROGER PERRON

*See also:* Activity/passivity; Conflict; Death instinct (Thanatos); "Instincts and Their Vicissitudes"; Life instinct (Eros); Masculinity/femininity; Reversal into the opposite; Sadomasochism.

### **Bibliography**

- Freud, Sigmund. (1905d). Three essays on the theory of sexuality. *SE*, 7: 123–243.
- . (1912b). The dynamics of transference. *SE*, 12: 97–108.
- . (1924c). The economic problem of masochism. *SE*, 19: 155–170.
- . (1950a [1887–1902]). Extracts from the Fliess papers. *SE*, 1: 173–280.
- . (1985c [1887–1904]). *The complete letters of Sigmund Freud to Wilhelm Fliess, 1887–1904* (Jeffrey Moussaieff Masson, Trans.). Cambridge, MA: Harvard University Press.

## **PANKEJEFF, SERGEI (1887–1979)**

Dr. Serguei Pankejeff, alias the "Wolf Man," is the subject of Freud's longest case history (1918).

According to our current Gregorian calendar, this remarkable patient was born on January 6, 1887, but according to the Julian calendar used at the time in Russia (and crucial to understanding his famous dream) he was born into a fabulously wealthy family on Christmas Eve, 1886. Marked psychopathology existed in the family on his father's side. His father himself was born in 1859; suffering from prolonged manic-depressive illness, he took a fatal overdose of veronal, in 1908; his mother was born in 1864 and died naturally in 1953. Serge's only sibling, Anna, who was two and a half years older than he, lethally poisoned herself in 1906.

Anna's suicide increased her brother's depression, and in 1908 he consulted some of the most eminent psychiatrists in Europe: Bechterev in Petersburg, Ziehen in Berlin, and Kraepelin in Munich. Serge spent a long time in German sanatoria, but it was in Kraepelin's that he met his future wife, Teresa Keller (she committed suicide in 1938). The Wolf Man's first analysis with Freud lasted from February, 1910, to July 14, 1914; subsequent to his dramatic impoverishment caused by the First World War, the Wolf Man went back into analysis with Freud from the fall of 1919 to Easter, 1920. For the next six years, Freud collected money for the sustenance and an occasional holiday for the Wolf Man and his wife. He eventually found employment in an insurance company and dealt with legal aspects of social security matters.

News of Freud's cancer contributed to the Wolf Man's subsequent psychotic decline. As a result, he went back into analysis with Ruth Mack Brunswick for a four-month period spanning 1926–1927. Starting in 1929, he resumed an irregular analysis with Brunswick for several years. Every summer from the mid 1950s to 1979, Kurt Eissler engaged the Wolf Man in "analytically directed conversations" and prescribed medication. He was also having irregular analytic treatment in Vienna during that time.

The Wolf Man's misery dramatically mounted over the last two decades of his life. Lonely and approaching senility, he was embroiled in a maddening relationship with a harmless psychopathic woman named Louise. Muriel Gardiner and Kurt Eissler monetarily supported them. He died in Vienna in 1979 at age 92. In sum, a fundamental feature of the Wolf Man's identity was his patienthood—he became a ward of psychoanalysis.

PATRICK MAHONY

*See also:* Anxiety dream; "From the History of an Infantile neurosis" (Wolf Man); Infantile neurosis; Urbantschitsch (Urban), Rudolf von.

### **Bibliography**

- Freud, Sigmund. (1918b [1914]). From the history of an infantile neurosis. *SE*, 17: 1–122.
- Gardiner, Muriel M. (Dir. [1971]). *The Wolf-Man by the Wolf-Man*. New York, Basic Books.
- Mahony, Patrick J. (1984). *Cries of the Wolf Man*. New York: International Universities Press.



Obholzer, Karin. (1982). *The Wolf-Man: conversations with Freud's patient—sixty years later*. (Michael Shaw, Trans.) New York: Continuum.

## PANKOW, GISELA (1914–1998)

A French psychiatrist and psychoanalyst, Gisela Pankow was born in Düsseldorf, Germany, on February 25, 1914, and died in Berlin on August 14, 1998. She came from a Christian democrat family that paid heavily for its active opposition to the Nazi regime. After obtaining degrees in mathematics, physics, geography, and philosophy at the University of Berlin, Pankow began studying medicine in Tübingen, where she became an assistant to Professor Ernst Kretschmer. She helped with his research in morpho-endocrinology and began to publish articles in the field.

Having arrived in Paris in 1950 with a grant to conduct research, she worked as an intern at the hospital of La Pitié under the direction of Jacques Decourt. She published articles in German and French. In February 1953 she obtained a doctorate in science from the University of Paris with a dissertation entitled “Les rapports métriques entre la base du crâne et la partie supérieure de la face.”

While following her medical and scientific studies, she began training in psychoanalysis in 1944, first in Germany with Luisa Weizsäcker (later Käte Weizsäcker-Hoss), then with members of the German Institute for Psychological and Psychotherapeutic Research (DIPF), and finally with Ernst Blum, a member of the Swiss Psychoanalytic Society, in Berne. In France she became a member of the Société Française de Psychanalyse (SFP) (French Society for Psychoanalysis) in 1953. For a while she attended Jacques Lacan's seminars at Sainte-Anne Hospital and conducted a number of supervised analyses with Lacan, Françoise Dolto, and Daniel Lagache.

In 1956 she published, in French, her first book (an abridged version of the German edition that appeared the following year): *Structuration dynamique dans la schizophrénie—Contribution à une psychothérapie analytique de l'expérience psychotique du monde*. With a preface by Juliette Favez-Boutonier, the book established the foundations of her research on the psychoanalytic approach to psychoses. After giving a series of conferences in Australia, in 1956 Pankow left for the United States to work as a research assistant at the psychiatry institute of the

University of Baltimore. She taught at John Rosen's Institute for Direct Analysis, met Gregory Bateson, Helen Flanders Dunbar, and most importantly, Frieda Fromm-Reichmann, who strongly encouraged her to continue her work.

She returned to France in late 1957, where she settled permanently. There, she introduced a private seminar in March 1958 and broke with the SFP in 1960, although she remained a member of the International Psychoanalytic Association. In 1960 she began teaching in the school of medicine of the University of Bonn. She also taught in Paris, at the Sainte-Antoine school of medicine (University of Paris VI), beginning in 1971. She participated in a number of international congresses and gave talks in several European countries, in Tunisia, the United States, Canada, and Australia.

Gisela Pankow was decorated with the cross of the Legion of Honor. She left behind a substantial body of writing—books and articles, in French, English, and German. Her work has been translated into Spanish, Italian, and Japanese. A remarkable clinician, she influenced several generations of psychotherapists in France and abroad through her insights and work on psychosis. In her practice she introduced an original technique involving modeling clay as a mediating element in transference dynamics. Deeply faithful to Freud, her work, enlivened by her extensive philosophical—primarily phenomenological—and scientific learning, is remarkably rigorous. Her theories, derived from clinical research, are based on the conception of an “image of the body,” which, according to Pankow, serves two functions. The first involves the recognition of spatial and formal structure, incorporating a dialectic of inside and outside, and part and whole; the second involves the content and meaning of that structure. The use of modeling enabled her to reveal the structural destructiveness of psychoses, the most serious of which affect the first function (*Kernpsychosen* or Kretschmer's “nuclear psychoses,” which are distinguished from *Randpsychosen*, or “marginal psychoses,” which affect only the second function). Her conceptual apparatus led the way to an understanding of psychotic experience and initiated, through a reintroduction of the symbolization process, a therapeutic strategy whose productivity proved itself in practice. “Transference graft” and “structuring fantasies” are two terms in Pankow's theory that qualify the essential moments of a therapeutic process that attempts to encourage the

psychotic patient to “build, inhabit, and think” the concreteness of his being.

MARIE-LISE LACAS

*See also:* Psychoanalyse, La; Psychoses, chronic and delusional.

### **Bibliography**

- Pankow, Gisela. (1957). *Dynamische strukturierung in der psychose, beiträge zur analytischen psychotherapie*. Bern: Hans Huber.
- . (1973). The body image in hysterical psychosis. *International Journal of Psycho-Analysis*, 55, 3, 407–414.
- . (1980). Rejection and identity. *International Review of Psycho-Analysis*, 7, 3, 319–32.
- . (1983). *L'Homme et sa psychose*. 3d ed. Paris: Aubier-Montaigne. (Original work published 1969)
- . (1983). *Structure familiale et psychose*. Paris: Aubier-Montaigne. (Original work published 1973).
- (Ed.). (1984). *Vingt-cinq années de psychothérapie analytique des psychoses*. Paris: Aubier-Montaigne.
- . (1987). *L'Être-là du schizophrène*. Paris: Aubier-Montaigne. (Original work published 1981)

## **PAPPENHEIM, BERTHA (1859–1936)**

Bertha Pappenheim was born in Vienna on February 27, 1859, and died in Frankfurt on May 28, 1936. Pseudonymously known as Anna O, she was the patient whose case Joseph Breuer presented in *Studies on Hysteria* (Freud and Breuer, 1895d).

People who knew Pappenheim and admired her as a pioneer social worker were shocked when Ernest Jones, in the first volume of his biography of Freud, revealed Anna O's real identity.

Bertha's father, Siegmund Pappenheim, was a wealthy Viennese merchant, descended from an old Jewish family from Germany; her mother, Recha Goldschmidt, gave birth to four children but only two, Bertha and Wilhelm, survived. Born in 1860, Wilhelm would become a famous attorney. Raised in a bourgeois household, Bertha learned English as a child and used it exclusively for a time during her illness; she also read French and Italian.

Reconstructions of Pappenheim's illness and the treatment she received, by such historians as Henri F.

Ellenberger (1972) and Albrecht Hirschmüller (1978), reveal many disparities in Breuer's account. When Breuer, a well-known specialist in Vienna, was first consulted in December 1880, Bertha was suffering from facial neuralgia and muscular contractions. These disorders were partly linked to the illness of her father, whom she nursed and to whom she was passionately attached. In a waking dream, her vision of a black snake preparing to kill her father was one of her first symptoms; a cough that Breuer qualified as “hysterical” followed soon after, in November 1880, when he began to see her regularly. The seriousness of her father's disease was concealed from her and Bertha was no longer allowed to visit with or care for him; after learning of his death, at age fifty-seven on April 5, 1881, she suffered a severe and newly debilitating set of hysterical symptoms, including an episode of “negative” hallucinations from which only Breuer was spared. Her family brought her to a country home outside Vienna. Breuer was seeing her regularly by the autumn of 1881, and during evening sessions, while in a state of self-hypnosis, she began recounting stories that she referred to as the “talking cure.” Breuer subsequently noticed that her “obstinate whims” disappeared when the fantastic thoughts that originated them could be evoked by this verbal “chimney sweeping,” as she called it.

During the summer of 1881, probably in mid-August (although Ellenberger dates it to early 1882), an incident occurred of considerable importance for the future of psychoanalysis. One of Bertha's symptoms was a refusal to drink water. While in an hypnotic state, she revealed that she had been disgusted to see her lady-companion's dog lapping water from a drinking glass; then, awakening from her hypnosis, she asked for a glass of water. From this incident emerged a new treatment aim in the discovery of etiological factors through what became known as the “cathartic method.” Breuer attempted to guide her to uncover the memories of events that would elucidate each of her multiple symptoms but which had apparently been forgotten.

Back in Vienna in November 1881, Bertha's condition worsened. She experienced a recrudescence of symptoms that caused her to reexperience events of the previous year. Employing the “cathartic method,” Breuer wrote that “[e]ach symptom with such care to detail that she linked each individual symptom in this complicated case was taken separately in hand; all the

occasions on which it had appeared were described in reverse order. ... When this had been described the symptom was permanently removed” (p. 35). Success was such that the date of termination for this treatment can be fixed to the end of June 1882. According to Breuer, “After this she left Vienna and traveled for a while; but it was a considerable time before she regained her mental balance entirely” (pp. 40–41). Indeed, Ernest Jones revealed Breuer’s shock when he was called the very evening of his departure from his patient, to be informed that she was showing signs of hysterical childbirth.

Various and contradictory accounts of Anna O’s termination of treatment persisted until research by historians revealed her hospitalization from July 12 to October 29, 1882, at the Kreuzlingen Clinic, under the direction of Robert Binswanger. Bertha was then suffering from severe trigeminal neuralgia, which Breuer had been treating for several months with chloral hydrate and morphine, the dosages of which had to be reduced during her hospitalization.

Relatively little is known about the rest of the story. Bertha and her mother, with whom she had a difficult relationship, settled in Frankfurt. Her health appears to have gradually improved, as Breuer noted. She served as headmistress of an orphanage for a dozen years. Under the pen name Paul Berthold (her initials reversed just as her pseudonym “Anna O” [A.O] was formed from the letters preceding her real initials [B.P]), Pappenheim wrote children’s short stories and even plays. She also translated the Memoirs of Gluckel von Hameln, a seventeenth-century maternal ancestor who had saved Jews from persecution. Breuer had correctly gauged the quality of Pappenheim’s intelligence.

In addition, Pappenheim became a prominent activist and social worker. After founding the Care for Women Society (*Weibliche Fuersorge*) to help young women after leaving orphanages, in 1904 she established the *Juedischer Frauenbund*, and served as its first president. With close ties to the German feminist movement, Pappenheim also fought for decades against the “white slave trade” that preyed on young women, who were often sold into servitude by their parents. She discovered the magnitude of white slavery during a journey to Galicia.

In 1905, upon the death of her mother, Pappenheim was free to travel. She first established a shelter for runaway girls and illegitimate babies near Frankfurt; a

year later, she left to visit America. She went to London in 1910, and spent 1911–1912 in Turkey, Jerusalem, Egypt, and Eastern Europe. Pappenheim continued to pursue social work during World War I and its aftermath and wrote numerous articles concerning Jewish women and criminality.

When Hitler came to power, Pappenheim found herself opposed to Zionist organizations that advocated relocation of Jewish children to Palestine without their parents. Suffering from intestinal cancer that forced her to cut down on her social and humanitarian activities, she died on May 28, 1936. That November, Nazis looted her home and destroyed her furniture and belongings. Most of her social worker colleagues died in concentration camps.

In 1945, Germany issued a stamp in a series titled “Helpers of Humanity” to honor her. Her relatives assembled elements for a biography; an initial version by Dora Edinger in 1963 was followed in 1972 by a version of her life, part fiction and part analytical, by Lucy Freeman.

In spite of critics of psychoanalysis, such as Mikkel Borch-Jacobsen, it is a simplification to attempt to falsify the story told in *Studies in Hysteria* with information subsequently discovered by historians. One should beware of edifying biographies of Pappenheim or of charging Josef Breuer with mystification. Symptoms alone offer insufficient data to a psychoanalyst and questions arise concerning the long-term effects of “mothering” that Bertha experienced in the context of a “fatherly” transference of which no one at the time had the slightest grasp or understanding. Clearly, symptomatic improvement in Pappenheim’s case was not immediate; however, her thorough personality transformation after the “talking cure” could be related to her treatment. Nothing is known of Pappenheim’s subsequent emotional and sexual life, and none of her friends or relations seemed to be aware of her youthful psychological problems prior to Ernest Jones’s disclosures in 1953.

ALAIN DE MIJOLLA

See also: Anna O., case of; Breuer, Josef; *Studies on Hysteria*.

### **Bibliography**

Edinger, Dora. (1968). *Bertha Pappenheim: Freud’s Anna O*. Highland Park, IL: Congregation Solel.

Ellenberger, Henri F. (1970). *The discovery of the unconscious. The history and evolution of dynamic psychiatry*. New York: Basic Books.

———. (1972). The story of “Anna O.”: a critical review with new data. In Micale, M.S. (Ed.). *Beyond the unconscious. Essays of Henry F. Ellenberger in the history of psychiatry*. Princeton, NJ: Princeton University Press, 1993.

Freeman, Lucy. (1972). *The story of Anna O*. New York: Walker.

Freud, Sigmund, and Breuer, Josef. (1895d). Studies on hysteria. *SE*, 2: 48–106.

Hirschmüller, Albrecht. (1989 [1978]). *The life and work of Josef Breuer*. New York: New York University Press.

---

## PARADE OF SIGNIFIERS

The concept of the parade of signifiers was formulated by Jacques Lacan in relation to his thesis that “the unconscious is structured like a language” and more specifically to his conception of unconscious desire. The speaking subject constantly expresses something of his or her desire by way of demand. Thus the parade of signifiers is structurally linked to the flow of speech. Since a single signifier never signifies anything as such, it is necessarily linked to others that form a chain of signifiers and, in fact, discourse, or a march of signifiers.

The series of signifiers that parades through speech has its source in the necessity of demand, which is always fundamentally a demand for the lost object (*das Ding*). This demand is repeated as a demand for the object of desire, object *a*, the object that remains forever lacking. In this sense, since desire is always inscribed between need and demand, it can have no other outcome than to make itself heard in the indeterminate series of signifiers that march through the signifying chain.

Through the intervention of the signifiers of the Name-of-the-Father, the structuring character of the paternal metaphor imposes a regulated order on this signifying parade. The absence of such regulation, which results from the foreclosure of the signifiers of the Name-of-the-Father, causes the chain of signifiers to disintegrate, as psychotic pathologies clearly show.

JOËL DOR

*See also:* Name-of-the-Father; Signifier/signified; Signifying chain; Subject’s desire.

## Bibliography

Lacan, Jacques. (1978) *The four fundamental concepts of psychoanalysis* (Alan Sheridan, Trans.). New York: W. W. Norton. (Original work published 1964)

———. (1998). *Le Séminaire-Livre V, Les Formations de l’Inconscient* (1957–58). Paris: Seuil.

———. (2002a) The instance of the letter in the unconscious, or reason since Freud. In *Écrits: A selection* (Bruce Fink Trans.). New York: W. W. Norton. (Original work published 1957)

———. (2002b) The subversion of the subject and the dialectic of desire in the Freudian unconscious. In *Écrits: A selection* (Bruce Fink Trans.). New York: W. W. Norton. (Original work published 1960)

---

## PARADOX

A paradox is defined, according to Paul-Claude Racamier, as a “mental formation that indissolubly binds two propositions or directives that are irreconcilable and yet not contradictory.”

This character of non-contradiction is essential. According to transactionalists, it is associated with the fact that irreconcilable prohibitions are not part of the same logical class, or, more simply, are not part of the same class (gesture and verb or affect and speech, for example). However, these irreconcilable directives can sometimes belong to the same class. In all cases the paradox results in infinite oscillations between two utterances of opposite meaning that are not contradictory but antagonistic—which is what accounts for its remarkable indeterminacy. The implicit conclusion of a paradox is that  $A = \text{not-}A$ . In 1952 Gregory Bateson and his colleagues began investigating the paradoxes of communication in men and animals.

We distinguish two kinds of paradox: logical paradox and pragmatic paradox. The most famous example of logical paradox, first formulated in antiquity by the Greek sophists, is attributed to Epimenides: “Epimenides the Cretan claims that all Cretans are liars. But Epimenides is a Cretan. Therefore he is lying when he says that Cretans are liars. But if Cretans are not liars, Epimenides is telling the truth.” Pragmatic paradoxes are practical paradoxes. We distinguish paradoxical forecasts from paradoxical prohibitions. The “double bind” is a sophisticated version of the paradoxical prohibition.

The introduction of the concept of paradox into psychoanalytic theory and clinical practice occurred

during the 1970s, from several different sources simultaneously. In France it is largely the result of Didier Anzieu's article "Transfert paradoxal" (Paradoxical transference; 1975) and Paul-Claude Racamier's "Humour et la folie" (Humor and insanity; 1973) and "Paradoxes des schizophrènes" (Paradoxes of schizophrenics); 1976, 1978, 1980). Anzieu insisted on the fact that paradoxical transference assumes, in individual or group psychotherapy, two forms: the paradoxical prohibition and disqualification, both of which are uttered by an individual or group in order to force psychoanalysts to contradict themselves and prevent the work of psychoanalysis from being accomplished. Paradoxical transference is thus one of the manifestations of the work of the negative. Paradoxical transference is accompanied by paradoxical resistance and paradoxical counter-transference.

Racamier extended the class of paradox to a type of mental and rational defensive organization—"paradoxicality"—which is found in schizophrenics, in whom it is both generalized and eroticized in particular ways. René Rousillon has investigated the formal nature of the paradox while contrasting it with the transitional class. Jean-Pierre Caillot used the concept of paradoxicality, applying it to interactive behavior and the psychoanalytic treatment of families engaged in psychotic transactions (1982). He described the paradoxical narcissistic position, where defense, through the oscillation of narcissistic and anti-narcissistic cathexes (Francis Pasche), against catastrophic, claustrophobic, and agoraphobic sensations or anxieties, characterizes the paradoxical narcissistic object relation. This position is comprised by the paranoid-schizoid position elaborated by Melanie Klein, where defense entails splitting and idealization. Caillot has defined paradoxical transference, whether individual, group, or familial, as a transference act or fantasy that indissolubly binds, self-referentially, two aspects of transference with opposite meanings, irreconcilable and yet non-contradictory. For example, Didier Anzieu has described the transference dream of a patient, in which he is simultaneously forced to remain at home and enjoined not to do so. This patient cannot remain in the analyst's office, nor can he leave it. Caillot and Gérard Decherf (1982) have described a paradoxical family transference where "living together kills and living apart is fatal."

According to Racamier, paradoxical behavior is obviously part of the general possibilities of the ego

and the avatars of human relations. But its prevalence as a clinically close-knit system is associated with an overwhelming defensive organization designed to fend off intrapsychic and group conflict, the risks of individuation and separation, the internal or collective movements of fantasies of desire and death, as well as dream images and feelings of mourning or disillusionment. It is used to foster feelings of omnipotence and is active in the denial of desire, of mourning, and of the difference between the sexes and generations.

JEAN-PIERRE CAILLOT

*See also:* Breakdown; Double bind; Psychoanalytic epistemology; Numinous (analytical psychology); Philosophy and psychoanalysis; Screen memory; System/systemic; Tenderness; "‘Uncanny,’ The"; Transference (analytical psychology); Transitional object.

### **Bibliography**

- Anzieu, Didier. (1975). Le transfert paradoxal. *Nouvelle Revue de Psychanalyse*, 12, 49–72.
- Caillot, Jean-Pierre, and Decherf, Gérard. (1982). *Paradoxalité et thérapie familiale psychanalytique*. Paris: Clancier-Guénaud.
- Racamier, Paul-Claude. (1980). *Les schizophrènes*. Paris: Payot.
- . (1998). Paradoxalité et ambiguïté. In S. Decobert, J.-P. Caillot, C. Pigott (Eds.), *Vocabulaire de psychanalyse groupale et familiale*, v. 1. Paris: Éditions du Collège de Psychanalyse Groupale et Familiale.
- Watzlawick, Paul; Beavin, Janet Helmick; and Jackson, Don D. (1967). *Pragmatics of human communication*. New York: W.W. Norton.

### **Further Reading**

- Pizer, Stuart A. (1992). The negotiation of paradox in the analytic process. *Psychoanalytic Dialogues*, 2, 215–240.

---

## **PARANOIA**

Paranoia has individual and institutional, social and cultural forms and determinants. There is probably at least a germ of paranoia in everyone which may be activated in regressive states with increased vulnerability. Clinically, paranoia may be found in mild transient forms, paranoid states of varying degree and duration, fixed paranoid traits and paranoid character, and bor-

derline schizophrenia. The range of paranoid conditions doubtless depends upon constitutional, characterological, and experiential variables.

Unlike other types of psychosis, a paranoid psychosis is usually well-defined, and more or less circumscribed in a delusional part of the personality. The disturbance may remain encapsulated or systematized without generalized tendencies toward deterioration of the overall personality.

The paranoid personality is characterized by a number of common traits: basic distrust; suspiciousness; readiness to feel slighted, injured or persecuted; a tendency to collect grievances and grudges; and vindictiveness. The paranoid personality either anticipates or fears being exploited and abused; is irrationally suspicious of hidden dangers or threats; and expects or believes in the infidelity of a spouse, the disloyalty of friends, and notions of hostile conspiracy. Betrayals are anticipated or assumed, so that for the paranoid friend may immediately become foe, and seeming affection may be replaced by an implacable animosity. Self-esteem issues are also apparent—connected with both the extraordinary sensitivity to narcissistic injury and humiliation, and concomitant grandiosity which may extend to megalomania.

The psychoanalytic understanding of paranoia was initiated by Freud (1911c) who, prior to the Schreber case, had already linked the defense mechanism of projection to the paranoia personality. Via projection, the paranoid defends against unacceptable impulses, especially hate and aggression, which are also related to paranoid defiance. The importance of regression to narcissism, with attendant hypersensitivity to narcissistic mortification and grandiosity associated with infantile omnipotence, was highlighted in the Schreber case. Grandiosity could also be a compensatory reaction to unconscious feelings of inadequacy and inferiority. However, Freud shifted the dynamic understanding of paranoia at the same time to a core oedipal conflict. The paranoid defense constellation warded off unconscious homosexual wishes. In the paranoid male the unconscious proposition: “I, a man, love him, a man,” is contradicted in the following ways: (1) delusions of jealousy: “It is not I who love the man; it is she,” (2) delusions of persecution: “I do not love him, I hate him. Because of this he hates and persecutes me,” (3) erotomania: “I do not love him. I love her, and she loves me,” (4) megalomaniac disavowal: “I do not love anyone else, but only myself.”

It should be noted that Freud’s formulations in the Schreber case were based upon the utilization of the libido theory and an attempt to understand paranoia in terms of psychosexual disturbance, which reversed his earlier formulation of repressed hostility. Subsequent contributions have confirmed the importance of malignant narcissism and the defense of projection, but also of hatred, aggression, and splitting of the ego and of self and object representations.

This defensive splitting off (Klein, Melanie, 1932) is also recognizable in group processes, as in the tendency to idealize one’s own group and to distrust and project evil and hostility to those outside the group, especially against defenseless minorities unable to counterattack. Paranoid processes may be discerned in various sects and ideologies, where there is devaluation and persecution of those who are seen as opposed to the sect or group’s narcissistically-invested belief system. In such dynamics, those who diverge may be scapegoated, and those who deviate or depart may be persecuted as heretics. Individuals with paranoid proclivities are far more readily attracted and susceptible to paranoid demagogues and groups. Paranoid leaders may foment and foster group paranoid reactions among vulnerable individuals. On the other hand, paranoid tendencies may contribute to individuals being vigilant guardians of civil liberty, ever-ready to detect a base of power and threats of exploitation. Feelings of being watched and scrutinized, so commonly seen with paranoid superego regression and externalization, may also have adaptive functions.

Contemporary understanding of the paranoid personality sometimes relates to circumstances in which a traumatic reality is embedded in fantasy, and historical truth in delusion (Freud, 1937d; Blum, 1994). There is often a history of childhood paranoia, so that pronounced narcissistic and paranoid features are already present in childhood. Feelings of mistrust, suspicion, and susceptibility to feelings of insult and injury may have been lifelong. The nightmares of paranoid patients may leave a hangover effect, so that the paranoid nightmare and terror of attack invades reality.

Traumatic experience with the terror of helplessness and inevitable narcissistic mortification may also be associated with severe and enduring vulnerability to narcissistic hurt and humiliation. Some cases involve selective identifications with paranoid parents.

Paranoid dispositions may be anchored in familial styles of paranoid suspicion and scapegoating, or blaming and vengeful familial attitudes.

Furthermore, the paranoid often not only detects the latent envy and hostility of others, but tends to activate and evoke hostile reactions as well. The paranoid's expectation of social slights and hurts becomes a self-fulfilling prophecy as their own suspiciousness and hostility arouses similar mistrusts and hostility in others. Freud (1922b) observed the tendency of the paranoid personality to recognize but exaggerate the imagined infidelity present in both partners. Since blame and guilt are projected, the paranoid remains indignant about innocent victimization and may become litigious. Narcissistic rage over feelings of injury and compensatory aggrandizement serve to undo and reverse traumatic helplessness and avenge prior narcissistic hurts and humiliations (Kohut, 1972). The paranoid's own urge toward betrayal becomes a means of vengeance, vindication, and mastery. A preemptive strike may be related to the paranoid's expectation of attack, betrayal, and the rationalization of a defensive counterattack. Any narcissistic frustration, disappointment, or traumatic disturbance may regressively activate a paranoid persecutory system. All levels of personality development may contribute to the paranoid persecutory system.

Current explanations of paranoia involve recognition of diffuse developmental disturbance without a single point of developmental fixation or deficit, appreciating the possibility of complex overdetermination. In paranoia, murderous hostility is now considered far more important than repressed homosexual love. There is a stress on preoedipal roots, leading to failure of oedipal resolution, and to the patient's vulnerability to malignant narcissistic regression (Kernberg, 1975).

Freud's proposition of the delusional reconstruction of the lost object world is still accepted by many analysts, while others have proposed different views concerning impaired reality testing and paranoid object relations. Reality testing, cognition, and affect regulation may be constitutionally fragile and further impaired by projection, traumatic injury, and ego regression. The paranoid personality may have many areas of intact ego, but it has been proposed (Blum, 1981; 1994) that the persecutor is a narcissistic object or a part object (Klein, 1932), incompletely differentiated from the self representation. In addition to the splitting

of representations, there is a regressive failure of object constancy with incomplete separation-individuation (Mahler, Margaret, 1971), and a desperate effort to reestablish object constancy within a constant persecutory relationship. The persecutory narcissistic object is sought, followed, or is imagined to be following the paranoid patient. The split-off dangerous object is the lesser evil when compared to objectless disorganization and fragmentation. Extreme ambivalence prevails, with the dominance of hate over love and with predominant projection of destructive rage, hatred, and self-hatred. Fear of being attacked by an invading or engulfing object is readily fused and confused because of unstable self-object differentiation, intrapsychic representation, and ego integration. Masochistic wishes to be attacked are less unpalatable to the paranoiac than the potentially malignant narcissism.

In national and social paranoia, concern with ego boundaries and narcissistic injury is reflected in concerns about national boundaries and enemy betrayal. The nation's integrity, and its boundaries, must then be defended because of fear of destructive invasion and engulfment.

The paranoid personality, depending upon the degree and fixity of the underlying disturbance, may be variably amenable to psychoanalytic treatment. Mistrust and lack of confidence in the analyst or therapist, fear of humiliation and abuse, coupled with an entrenched and entitled narcissism make the paranoid patient a major therapeutic challenge. For those patients amenable to psychoanalysis, consistent interpretation of paranoid transference manifestations, management of paranoid regression, and awareness of the patient's ego fragility and extreme ambivalence are of critical importance.

HAROLD P. BLUM

*See also:* Narcissism; Paranoid position; Paranoid-schizoid position.

### **Bibliography**

- Blum, Harold P. (1994). Paranoid betrayal and jealousy: the loss and restitution of object constancy. In J. Oldham, S. Bone (Eds.), *Paranoia: New psychoanalytical perspectives*. Madison: International Universities Press, p. 97–114.
- Freud, Sigmund. (1911c [1910]). Psycho-analytic notes on an autobiographical account of a case of paranoia (dementia paranoides). *SE*, 12: 1–82.

———. (1922b [1921]). Neurotic mechanisms in jealousy, paranoia and homosexuality. *SE*, 18: 221–232.

———. (1937d). Constructions in analysis. *SE*, 23: 255–269.

Kernberg, Otto. (1975). *Borderline conditions and pathological narcissism*. New York: Jason Aronson.

Kohut, Heinz. (1972). Thoughts on narcissism and narcissistic rage. *The search for the self*. (Vol. 2.) New York: International Universities Press, p. 615–65.

### Further Reading

Auchincloss, Elizabeth L., and Weiss, Richard W. (1992). Paranoid character and the intolerance of indifference. *Journal of the American Psychoanalytic Association*, 40, 1013–1038.

Blum, Harold P. (1980). Paranoia and beating fantasy: psychoanalytic theory of paranoia. *Journal of the American Psychoanalytic Association*, 28, 331–362.

Kernberg, Otto F. (1992). Psychopathic, paranoid, and depressive transferences. *International Journal of Psychoanalysis*, 73, 13–28.

Meissner, William. (1986). *Psychotherapy and the paranoid process*. Northvale, NJ: Jason Aronson.

Oldham, John M., and Bone, Stanley. (Eds.). (1994). *Paranoia: New psychoanalytic perspectives*. Madison, CT: International Universities Press.

## PARANOIA (FREUDIAN FORMULAS OF)

“Paranoia” is one of the oldest concepts in the history of the description of mental states. It initially appears in Greek tragedy, on two occasions; first to describe the passionate love of Oedipus and Jocasta and then to refer to Orestes’ state following his murder of his mother, Clytemnestra.

For most of the 19th century, the term paranoia occupied a position of the same importance as the term “schizophrenia” today. It was then understood as a mental state that was characterized by feelings of persecution on all sides. Freud’s approach to paranoia, as to psychopathology in general, brought to it a perspective that is simultaneously dynamic, topographical, genetic, and economic. It is dynamic in that Freud regards paranoia as deriving from a form of psychic activity, namely projection; topographical because this projection, initially connected with incestuous fantasies and later with homosexuality, is based on uncon-

scious impulses; and genetic because the seduction experiences that stimulate these incestuous or homosexual impulses occur at an early stage. Finally, this perspective is also economic in that paranoia, like every other symptom, is an “attempt at reconstruction” directed at protecting the subject from more acute problems.

Freud took an interest in paranoia from the outset of his work, comparing it with other forms of psychopathology. His analysis (Freud, 1911c [1910]) of Daniel Paul Schreber’s *Memoirs of My Nervous Illness*, which contains the essence of his theories on the subject, nevertheless poses a few problems.

The connection between paranoia and homosexuality emerged late in Freud’s work. Initially, if homosexual elements were present at all, they were overlooked and it was incestuous relationships or fantasies that were emphasized. In fact, the connection between homosexuality and paranoia seems to have resulted from some collaborative work by Freud, Carl Gustav Jung, and Sándor Ferenczi. Furthermore, the analysis of homosexuality based on the *Memoirs* differs from the analysis based on Leonardo da Vinci’s childhood memory. Whereas the former involves a romantic fixation on someone of a different sex from the subject, the latter is entirely focused on his relations with someone of the same sex.

What Schreber reveals of the progress of his “nervous illness” demonstrates few of the characteristics of paranoia, or even paraphrenia or paranoid dementia. In fact, he describes the natural and spontaneous development of a psychosis, throughout its progression and in all its forms, without any substantial medical intervention. Instigated by a moment of hypochondria that rapidly turns into a catatonic breakdown, this progression leads him into a paraphrenic phase that gives way to paranoia before concluding in a transvestite perversion with strong hysterical components, which is followed by a rather successful professional reintegration.

Freud incorporates within paranoia the classic forms of delusions of persecution, erotomania, jealous delusions, and megalomania, but he overlooks querulousness and discursive mania. The formulas that Freud puts forward for understanding repression and the return of the repressed in paranoia are problematic in spite of their value. He suggests that a single formula—“*I (a man) I love him*” is denied in four ways:



- a. "I do not *love* him—I *hate* him," which is transformed by projection into, "*He hates* (persecutes) *me*" (1911c, p. 63), giving rise to delusions of persecution;
- b. "I do not love *him*—I love *her*." As a result of projection, this becomes: "I observe that *she* loves me" (p. 63), which leads to erotomania;
- c. "It is not *I* who love the man [or woman]—*she* [or he] loves him [or her]" (p. 64), which characterizes jealous delusions;
- d. "*I do not love at all*—*I do not love any one*" (p. 65), which becomes "I love only myself."

Karl Abraham made some variations to these formulae to deal with manic-depressive psychoses. He grafted the essence of formula (a), that is, the inversion of the affect combined with projection, on to formula (d). The formula "*I do not love anyone*" that Freud proposes is only one of the possible consequences of "*I do not love at all*"; the other obvious consequence is "*I do not love at all—I hate*," or even "*I hate the whole world*," a fantasy that can appear in conjunction with "*I love only myself*." Schreber's delusion of grandeur in fact portrays a world that has been completely destroyed. Freud explains this fantasy purely in terms of libidinal decathexis but the need for libido to be cathected does not necessarily mean that this concerns the ego. The libido can disperse, with "*I hate the whole world*" being extended into "*including myself*." Schreber attempted suicide and asked to be killed.

Finally, formula (d) can also appear in another form in delusions of grandeur: "*I do not love anyone—I love the whole world*," which is expressed in the delusions of mystics concerning the salvation of humanity and the transformation of the world, which also appear in the *Memoirs*.

There is a further equation of this: "*I love the whole world, but the world hates me*," which is expressed in paranoid masochism, when hatred presents itself as the guarantee of a supreme love.

The application of the formula for delusions of persecution (a) to the formula for jealous delusions (c) concerns the subject's feeling of persecution by the couple of whom he is jealous. The complete formula here is: "It is not *I* who love the man *and* the woman—it is *they* who love *each other*. *I hate them*"; and, by projection, "*it is they who hate me*," who despise me and so on.

The formula (b) applied to formula (c) produces "It is not *I* who love the man *and* the woman—it is *they* who love *me*," a fantasy that is not unusual in erotic delusions, particularly in the form that leads to the "ménage à trois," whether preceding or following the jealousy, the pleasurable aspect of which barely conceals the anxiety. Daniel Lagache pioneered the study of the connection between erotomania and jealousy, as well as the study of ideas of homosexual infidelity in jealousy.

There is also the application of formula (a) to formula (b) and vice versa, as elaborated by Luiz Eduardo Prado de Oliveira. In the first case, the formula for homosexual erotomaniac delusion appears as: "I (a man) love him (a man)" and by projection: "I do not love him—he loves me," a fantasy that emerges clearly in Schreber's *Memoirs* and in clinical practice. In the second case, there is a close connection both between jealousy and erotomania and between erotic delusions and feelings of persecution. If these formulae are then applied to each other: "I love her (a woman). No, I hate her," and by projection, "I observe that she hates me," the woman appears as the man's persecutor, just as the man can appear as the woman's persecutor. These observations, entirely based on the wide range of phenomena in clinical practice, are an extension of the foundation constituted by Freud's work.

These developments as a whole illustrate the heuristic innovativeness of Freud's and they encompass a much broader spectrum of possibilities in the clinical field. Freud's for understanding paranoia also gave rise to the concept of foreclosure, developed by Lacan as a result of an error in the early French translations and initially accepted as an adequate basis alone for understanding the psychoses.

At very early stage, Freud drew a distinction between three variations of repression: repression concerning affect alone; repression concerning mental representation alone; or, finally, in the most extreme case, concerning both affect and mental representations, in which all the processes occur outside the ego. In his early studies on paranoia, each of these forms of repression found an outlet in projection. In his Schreber study, Freud uses the term *Verwerfung* (foreclosure or repudiation) to characterize the third form of repression. Freud's first translators into French had simply—and incorrectly—retained the term "projection" Lacan, seeing this as a flagrant mistranslation and connecting it with his work on the symbolic law,

introduced the term “foreclosure” (*forclusion*) in its place. In an everyday linguistic system such as Freud used, the term would have been better translated into French by the concept of “rejet” or “refus” (“rejection” or “refusal”), which is more closely reflected in the alternative English term repudiation. The correction of this translation error at the origin of the concept of foreclosure has certainly indicated a difficulty concerning the formation of psychoses and today this term is as widely accepted as the term “projective identification” which originates from Tausk’s writings.

LUIZ EDUARDO PRADO DE OLIVEIRA

### Bibliography

Abraham, Karl. (1912). Préliminaires à l’investigation et au traitement psychanalytique de la folie maniaco-dépressive et des états voisins *OC*, t. I, p. 99–113.

Freud, Sigmund. (1896b). Further remarks on the neuro-psychoses of defence. *SE*, 3: 157–185.

———. (1911c [1910]). Psycho-analytic notes on an autobiographical account of a case of paranoia (dementia paranoides). *SE*, 12: 1–82.

Lagache, Daniel. (1977). Contribution à l’étude des idées d’infidélité homosexuelle dans la jalousie. (Communication au XVe Congrès International de Psychanalyse. Paris 1938). In *Les hallucinations verbales et travaux cliniques* (Oeuvres I [1932-1946], pp. 225–242). Paris: Presses Universitaires de France. (Original work published 1938)

Prado de Oliveira, Luiz E. (1997). *Freud et Schreber. Les sources écrites du délire, entre psychose et culture*, Paris: Érès.

## PARANOID POSITION

Young children are frequently afflicted by paroxysms of anger and fear. Underlying these panics and night terrors is a vicious circle, an unconscious fantasy, involving fear of, and attacks upon, a malign “bad” object.

The term is first used in Melanie Klein (1932), however the descriptions of aggression and paranoia go back to her earliest writings, but notably Klein (1927b, 1928, 1929a and b).

Klein found that children’s symptoms were often based in an extreme anxiety about the child’s own desired aggression towards important and loved people. This conflict represents the infant’s version of the

super-ego conflict described by Freud. As the symptoms that Klein analyzed had arisen in infancy—before the age of one—she assumed the super-ego arose at that early age.

Klein described these “anxiety-situations” as she called them, following Freud (1926), and found that she could analyze them with her “technique of early analysis.” It appeared that the aggression the child exhibited towards the object that frustrated it, gave rise to a belief that the object would retaliate, with equal violence towards the child (Klein, 1927b, 1929a, 1930, 1932). This fear arising from the child’s own aggression often resulted in even greater attacks, in fantasy, on the feared object in order to finally dispose of it. That increase in aggression then led to an increased fear that the now dead object would rise from the dead, and retaliate with even greater force. These crescendos of aggression led to children having paroxysms of fear, such as *pavor nocturnus*, panic attacks, or other symptoms.

At first Klein called this state of aggression and retaliation the “paranoid position.” However, the term did not survive her introduction of the depressive position (Klein, 1935). Later, the nature of this kind of experience became clearer as she described the paranoid-schizoid position (Klein, 1946).

Freud’s view of paranoia was that it hid an underlying homosexuality, such that an underlying love turned to hate (Freud, 1911). This contrasts with the Kleinian “anxiety-situation” that hate overwhelms love. In Rosenfeld’s view, homosexuality covers an underlying unconscious paranoia (Rosenfeld, Herbert, 1949).

With the introduction of the theory of the depressive position, it was understood that the crises of terror in children (Isaacs, Susan, 1939) and adults (Heimann, Paula, 1942) were about internal objects. Later, descriptions of the paranoid-schizoid position presented these internal states of persecution in more thorough detail.

ROBERT D. HINSHELWOOD

*See also:* Paranoid-schizoid position; Privation; Stammering; Thought-thinking apparatus.

### Bibliography

Heimann, Paula. (1942). Sublimation and its relation to processes of internalization. *International Journal of Psycho-Analysis*, 23, 8–17.

Klein, Melanie. (1926). Les principes psychologiques de l'analyse des jeunes enfants. *Essais de psychanalyse (1921–1945)*. Paris : Presses Universitaires de France.

———. (1927). Symposium on child analysis. *International Journal of Psycho-Analysis*, 8, 339–370.

———. (1928). Early stages of the oedipus conflict. *International Journal of Psycho-Analysis*, 9, 167–180.

———. (1929a). Infantile anxiety situations reflected in a work of art and in the creative impulse. *International Journal of Psycho-Analysis*, 10, 436–443.

———. (1929b). Personification in the play of children. *International Journal of Psycho-Analysis*, 10, 171–182.

———. (1932). *The psycho-analysis of children*. London: Hogarth.

———. (1935). A contribution to the psychogenesis of manic-depressive states. *International Journal of Psycho-Analysis*, 16, 145–174.

———. (1946). Notes on some schizoid mechanisms. *International Journal of Psycho-Analysis*, 27, 99–110.

Rosenfeld, Herbert. (1949). Remarks on the relation of male homosexuality to paranoia, paranoid anxiety and narcissism. *International Journal of Psycho-Analysis*, 30, 36–47.

## PARANOID PSYCHOSIS

In the sixth edition (1899) of his *Lehrbuch der Psychiatrie*, Emil Kraepelin, spoke of dementia praecox as an autonomous illness, describing three major forms: hebephrenia, catatonia, and paranoid dementia.

In its conception, the paranoid forms of dementia praecox are opposed to the systematized delusions of paranoia. The paranoid grouping of dementia praecox is characterized by its disintegration, apparent incoherence, a progressive cutoff from the world and growing insanity, all notions that Eugen Bleuler will reduce to the fundamental process of dissociation (“*Spaltung*”) in schizophrenia, substituting this term (1911) for that of “dementia praecox.” On the other hand the polarity represented by the paranoid’s delusion distinguishes itself by the systematization of the delusions in the form of unshakeable convictions, developed in an orderly manner and clearly, and in the absence of any tendency of deterioration. A third group with chronic delusions corresponds to the observations of Kraepelin, and designated by him with the term “paraphrenia,” had two characteristics: they had constructions that were more or less chaotic, based on fantastic themes and hallucinatory mechanisms, but maintained their intel-

lectual integrity, and their adaptation to the exigencies of reality.

Under the term “paraphrenia” Freud proposed uniting the different clinical categories of dementia praecox, and then of schizophrenia. While maintaining the Kraepelinian distinction between paranoia and schizophrenia which includes paranoid dementia, he nevertheless stressed certain kinds of relation between the two conditions and the possibility of combinations of symptoms of the two types. He used, in some of his writings, the term “paraphrenia” to designate the paranoia-schizophrenia grouping. He emphasized more the underlying fixations and mechanisms than the criteria for systematization of the form of delusions. It was therefore the defense against homosexuality in the “Schreber case” (1911c [1910]) that led Freud to situate this clinical picture on the side of paranoia, in spite of a number of paranoid dementia aspects. He didn’t exclude forms of passage from one condition to another, situating fixation in schizophrenia at a theoretical level anterior to the closer development of autoerotism. For him, hallucinatory mechanisms prevalent in schizophrenia linked it rather to hysteria, while projection in paranoia evoked certain traits of obsessive neurosis.

Finally, the paranoid-schizoid position of Melanie Klein refers to fears of persecution, linked to primal sadistic-oral ambivalence, able to manifest itself subsequently in schizophrenia and paranoia.

BERNARD TOUATI

*See also:* “On the Origin of the ‘Influencing Machine’ in Schizophrenia”; “On Narcissism: An Introduction”; Paraphrenia; “Psycho-Analytic Notes on an Autobiographical Account of a Case of Paranoia (Dementia Paranoides)”; *Psychology of Dementia praecox*; Psychoses, chronic and delusional; Schizophrenia.

### Bibliography

Ey, Henri. (1939). Group of schizophrenics. *Encyclopédie médico-chirurgicale*, volume *Psychiatrie*. E.M.-C., fasc. 37-281-C-10.

Freud, Sigmund. (1911c [1910]). Psycho-analytic notes on an autobiographical account of a case of paranoia (dementia paranoides). *SE*, 12: 1–82.

———. (1914c). On narcissism: an introduction. *SE*, 14: 67–102.

Laplanche, Jean, and Pontalis, Jean-Bertrand. (1974). *The language of psychoanalysis* (Donald Nicholson-Smith, Trans.). New York: W. W. Norton.

## PARANOID-SCHIZOID POSITION

In the paranoid-schizoid position, first described by Melanie Klein in 1946, the earliest experiences of the infant are split between wholly good experiences with “good” objects and wholly bad experiences with “bad” objects. The ego protects itself from the bad ones by a mechanism that splits the ego itself.

Freud, at the end of his life, was interested in the splitting of the ego (Freud, 1940e [1938]). He had come, as it were, full circle from his earliest interest in dissociation in hysteria, via the manic-depressive psychosis, back to fragmenting processes that resemble schizophrenia. This was addressed too by Ronald Fairbairn (1941).

Working with severely disturbed patients, Klein identified the disintegrating forces within the early ego, and its struggle to develop a consistency within itself. This early dynamic of falling into pieces and pulling itself together again represented, for Klein, the conflict between the life and death instincts. So, the key anxiety-situation of this position is the fear of being destroyed from within. Klein and her followers (Rosenfeld, Herbert, 1950; Segal, Hanna, 1952) described this as the core anxiety of the schizophrenic, that which the schizophrenic feels to be overwhelming, that from which the schizophrenic is unable to recover. In contrast, the normal infant survives without the belief that it has been irretrievably fragmented. Usually the infant has various resources with which to keep this anxiety sufficiently mastered. In the first place the infant uses a number of primitive defense mechanisms—splitting, projection, introjection, identification, denial (annihilation), and idealization.

Central and above all is splitting. Already fearing itself under attack from within, the ego re-orders its senses of self and object. It reconstructs its reality into a coherent picture of good elements and bad ones, which are split apart. These collections of fragments can then be processed by the other primitive mechanisms. In particular, as Freud described, the bad parts of the self and the object are expelled and believed to be a property of the external world, leaving the ego to contain only the good elements.

These fantasies and mechanisms constitute narcissism from a Kleinian point of view, and involve projective identification and splitting as fundamental mechanisms of defense.

This set of fantasies is based upon the view that the infant, from the beginning, has a sense of the boundary between its internal world (self) and the external world. Contrary to Freud’s view, the death instinct is clinically visible in these states. The disintegration of the ego (under pressure to split off parts of itself) poses for the infant a struggle to master these disintegrating forces within. It may do so by directing the attacks of the death instinct toward the goal of forming coherent splits in the ego.

The death instinct, at first directed internally against the self, can, due to the projective processes, be partly redirected outwards against the now “bad” external objects. But in the process, the death instinct is also split, and the self-directed attacks are then seen as coming from outside, from the attacked object. This leads to illusions of a very persecutory nature. Such a projection of the self-attack into an external object creates an attacking external object. If introjected again that external object takes on the eventual form of a persecuting internal object, resembling a harsh super-ego.

Another capacity the infant has for combating the anxiety of fragmenting is its internalization of a good object. If the external object has some consistency in the external world, then when introjected it can form the basis from which an internal consistency can grow. This is Klein’s view of the origins of a coherent and relatively consistent sense of self. The achievement of a stable good internal object is the beginning of the depressive position, and represents a developmental move from the paranoid-schizoid to depressive position.

On the other hand, the failure adequately to develop this secure internal object gives a prolonged deficit in the development of the depressive position. This may later take the form of schizophrenia (Rosenfeld, 1965); or lead to a borderline state in which the anxiety situations of both positions are effectively avoided through a retreat into a pathological organization out of touch with any emotional life (Steiner, Riccardo, 1993). Some infants seem particularly prone to fail in introjecting a good external object and thus establishing a secure internal one. This may be due to various factors: a projection of the death instinct into the objects, good and bad, in the external world; or an intense envy of external good objects; or the actual absence of a consistent enough external good object; or indeed to a combination of all three.

The intricacy of the fantasy activity involved in these primitive processes is regarded by some as improbable. It is also questioned whether fantasy activity alone can be formative of the mind and of character. This position implies, to many analysts, that Klein viewed development advancing on the basis of internal states only and solipsistically remote from the external world.

ROBERT D. HINSHELWOOD

*See also:* Alpha function; Archaic; Archaic mother; Defense mechanisms; Depressive position; Eroticism, anal; Fragmentation, feelings of, (anxiety); Helplessness; Infant observation; Infantile psychosis; *Learning from Experience*; Oedipus complex, early; Paranoid position; Projective identification; Selected fact; Symbolic equation.

### Bibliography

Fairbairn, W. Ronald D. (1941). A revised psychopathology of the psychoses and psychoneuroses. *International Journal of Psycho-Analysis*, 22, 250–279.

———. (1940e [1938]). Splitting of the ego in the process of defence. *SE*, 23: 271–278.

Klein, Melanie. (1946). Notes on some schizoid mechanisms. *International Journal of Psycho-Analysis*, 27, 99–110.

———. (1955). The psycho-analytic play technique: its history and significance. In Klein, Heimann and Money-Kyrle (Eds.), *New directions in psycho-analysis*. London: Tavistock Publications.

Rosenfeld, Herbert. (1950). Note on the psychopathology of confusional states in chronic schizophrenia. *International Journal of Psycho-Analysis*, 31, 132–137.

———. (1985). *Psychotic states: a psychoanalytic approach*. London: Hogarth; repr. London: Karnac Books. (Original work published 1965)

Segal, Hanna. (1952). A psycho-analytic contribution to aesthetics. *International Journal of Psycho-Analysis*, 33, 196–207; Klein, Heimann and Money-Kyrle (Eds.). (1955). *New directions in psycho-analysis*. London: Tavistock Publications, p. 384–407.

Steiner, Riccardo. (1993). Introduction. (p. 21–49). In R.A. Paskauskas (Ed.), *The complete correspondence of Sigmund Freud and Ernest Jones*. Cambridge: Harvard University Press.

---

## PARAPHRENIA

German psychiatrists in the 19th century employed the term *paraphrenia*, derived from the Greek *para*

(beyond) and *phrēn* (mind), as a nonspecific term for madness. In 1863 Karl Ludwig Kahlbaum used *paraphrenia hebetica* to designate a degenerative malady of puberty, later known as hebephrenia.

Emil Kraepelin, in the eighth edition of *Dementia Praecox and Paraphrenia* (1919), which was published in four volumes beginning in 1908, proposed paraphrenia to designate chronic delirious psychoses unaccompanied by intellectual decline; he suggested four different clinical types: *systematica*, *expansiva*, *confabulans*, and *phantasica*.

Freud believed paraphrenia to be a more properly descriptive term than schizophrenia, the term Eugen Bleuler suggested to replace Kraepelin's dementia praecox. He used it for the first time in his "Psycho-Analytic Notes on an Autobiographical Account of a Case of Paranoia (Dementia Paranoides)" (1911c). Although Bleuler's term became prevalent, Freud employed paraphrenia again in "The Disposition to Obsessional Neurosis: a Contribution to the Problem of Choice of Neurosis" (1913i) and in "On Narcissism, an Introduction" (1914c). Subsequently it came up again twice, first in the *Introductory Lectures on Psycho-Analysis* (1916–17a) and in the second published version of "The Disposition to Obsessional Neurosis." Strangely enough, the term did not surface at all in the long discussion of the mechanisms of schizophrenia in the metapsychological article on "The Unconscious" (1915e), nor in "A Case of Paranoia Running Counter to the Psycho-Analytic Theory of the Disease" (1915f). It was also missing from the two articles on "Neurosis and Psychosis" (1924b) and "The Loss of Reality in Neurosis and Psychosis" (1924e).

It is difficult to understand why Bleuler's term became preferred usage, although certainly this was due in part to the notion of "split" (*schizo*). However, although paraphrenia did not gain currency, on a nosological level Freud's reasoning, as developed particularly in the Schreber case, was quite remarkable and in line with his earlier attempts at diagnostic precision concerning neurosis. Freud maintained in effect that paranoia must be viewed as a clinical type distinct from schizophrenia, even if the overall clinical picture is complicated by schizophrenic-like characteristics. The two conditions can be distinguished by the central obsession and by a different mechanism of symptom formation.

NICOLAS GOUGOULIS

See also: Hypochondria; *Introductory Lectures on Psychoanalysis*; Narcissism, secondary; “On Narcissism, An Introduction”; Paranoid psychosis; Psychoanalytic nosography; Psychoses, chronic and delusional; Schizophrenia.

### Bibliography

- Delrieu, Alain. (1997). *Sigmund Freud. Index thématique*. Paris: Anthropos.
- Freud, Sigmund. (1911c). Psycho-analytic notes on an autobiographical account of a case of paranoia (dementia paranoides). *SE*, 12: 1–82.
- . (1913i). The disposition to obsessional neurosis: a contribution to the problem of choice of neurosis. *SE*, 12: 311–326.
- . (1914c). On narcissism: an introduction. *SE*, 14: 67–102.
- . (1915e). The unconscious. *SE*, 14: 159–204.
- . (1915f). A case of paranoia running counter to the psycho-analytic theory of the disease. *SE*, 14: 261–272.
- . (1916–17a). Introductory lectures on psycho-analysis. Part I, *SE*, 15; Part II, *SE*, 16.
- . (1924b). Neurosis and psychosis. *SE*, 19: 147–153.
- . (1924e). The loss of reality in neurosis and psychosis. *SE*, 19: 180–187.
- Kapsambelis, Vassilis. (1997). *Termes psychiatriques français d'origine grecque*. Paris: Masson.
- Kraepelin, Emil. (1971[1919]). *Dementia praecox and paraphrenia*. New York: Robert E. Krieger.
- Porot, Antoine. (1952). *Manuel alphabétique de psychiatrie*. Paris: Presses Universitaires de France.

## PARAPRAXIS

A parapraxis is an act that appears to be unintentional but can be understood, through psychoanalytic exploration, to be perfectly motivated and unconsciously determined. A brief and delimited disturbance that may be spontaneously explained as the result of chance or inattention, a parapraxis may be readily perceived by its initiator or by a third party to be a “mistake.”

Parapraxes include a wide range of events, including failures of memory, slips of the tongue or pen, mistakes, and bungled or accidental acts. A parapraxis cannot be explained by referring to the nature of the “slip” itself, but psychoanalytic hypotheses make it possible for it to

be described simultaneously as a mistake and not a mistake, depending on one’s point of view.

Parapraxes interested Freud as early as 1890. In letters to Wilhelm Fliess, he created a virtual collection of examples communicated to him by correspondents. Parapraxes represented, in fact, an important demonstration of disturbances created by the unconscious. As opposed to dreams, parapraxes tend to require fewer biographical details while providing valuable evidence—indeed, often with comical effect—that offers a popular audience an easy way to grasp psychoanalysis. Furthermore, parapraxes constitute one of the pillars of the psychopathology of everyday life, which Freud considered necessary to understand mental pathology in a broader context.

Freud discusses parapraxes in two of his major works: *Psychopathology of Everyday Life* (1901b) and *Introductory Lectures on Psycho-Analysis* (1916–17a [1915–17]).

Beyond the anecdotal nature of many of the examples in these two works, parapraxes clearly raise an issue fundamental for psychoanalytic thought—namely, the link between psychic determinism and the unconscious. Freud was led to clarify his position toward the notion of “chance” (as discussed in the review *Topique*, 1997) as differentiated from superstition: “I do not believe that an event in whose occurrence my mental life plays no part can teach me any hidden thing about the future shape of reality; but I believe that an unintentional manifestation of my own mental activity *does* on the other hand disclose something hidden, though again it is something that belongs only to my mental life [not to external reality]. I believe in external (real) chance, it is true, but not in internal (psychical) accidental events.” (Freud, 1901b, p328)

The link between parapraxes and psychopathology, moreover, is established, according to Freud, uniquely through the fact that, in the case of chance events in a real world, “slips” involve the most insignificant psychic events. By contrast, neurotic symptoms are related to the most important psychic functions from both individual and social perspectives. In both instances, however, the same processes enable such symptoms to be understood, that is, as compromise formations located between desire and defense, between a subject’s conscious intention and repression.

SOPHIE DE MIJOLLA-MELLOR

See also: “Claims of Psychoanalysis to Scientific Interest”; *Psychopathology of Everyday Life, The*; Repression.

### **Bibliography**

Freud, Sigmund. (1901b). The psychopathology of everyday life. *SE*, 6.

———. (1916-17a[1915-17]). Introductory lectures on psycho-analysis. *SE*, 15–16.

*Topique*. (1997).

## **PARCHEMINEY, GEORGES (1888–1953)**

Georges Parcheminey, the French psychoanalyst, was born on April 21, 1888, at Ronchamp in the Haute-Saône department, and died in Paris on July 29, 1953.

Born of a music-teacher mother and a mining-engineer father, he was educated in a religious institution where he studied the classics, before going to Paris to study medicine. In 1917 he married a woman who shared his passion for music. Wounded during the First World War, he first practiced as a general practitioner and then as a neurologist.

During the 1920s he was analyzed by Rudolf Loewenstein and, having contributed in 1925 to the creation of *Évolution psychiatrique*, in 1926 he was one of the co-founders of the Paris Psychoanalytic Society (SPP). René Laforgue was president of the Society for its first four years, followed by Parcheminey for the period 1930–31.

Having worked as a Physician-Captain during the 1939 war, he was demobilized when Prof. Laignel-Lavastine appointed him laboratory director in the medical faculty where, in spite of the Occupation, he lectured on psychoanalysis in the Mental Health Clinic. Prof. Jean Delay, who then took over this department of the Sainte-Anne hospital, retained his position for him until after the Liberation.

He was training analyst for Maurice Bénassy and Maurice Bouvet from 1942 and was president of the short-lived National Syndicate of Psychoanalyst Physicians, created in April 1951. He played a leading role in the discussions preceding the creation of the Institute of Psychoanalysis and, as senior member, he resumed presidency of the SPP on the dramatic evening when the split occurred on June 16, 1953, three months before his death.

His knowledge of German enabled him to read Freud in the original and his writings focused mainly on neurosis—the subject of his lessons at the Institute of Psychoanalysis—and conversion hysteria. He studied the links between the psychic and the somatic and compared Pavlov’s work with that of Freud.

His first article, which appeared in the *Revue Française de Psychanalyse* (French review of psychoanalysis) in 1928, was co-authored with Édouard Pichon and was entitled “Sur les Traitements Psychothérapeutiques Courts d’Inspiration Freudienne chez les Enfants” (On short Freud-inspired psychotherapeutic treatment for children). Each of the two authors related a case in which the patient was “cured” in one session. In 1932, in his report to the sixth Congress of French-Speaking Psychoanalysts, he presented a critical study of the different conceptions of “conversion hysteria.” He compared the theories of Janet, Babinski, Dupré, Claude and Lhermitte, Kretschmer, and Pavlov, with those of Freud and Breuer, which he explained in detail.

In “La Problématique du Psycho-Somatique” (The problem of the psychosomatic), an article dating from 1948, he asserted that this term, created by Mrs. Dunbar and her school in the United States, was in fact a logical extension of Freudian notions concerning the theory of the neuroses and particularly the study of hysteria. Psychosomatic medicine did not exist for him, “it is only an artificially isolated section of an anthropological conception of medicine, a more synthetic vision of all human existence.”

At the time of his death in 1953, Michel Cénac wrote: “He was called on to act as president at difficult times, when it was essential to recover control of techniques that some had practiced with a greater or lesser degree of success. Under these circumstances he knew how to act in a balanced and wise manner and the unit came together thanks to his diplomacy and tact. . . . His love of harmony led him to sacrifice himself for its sake, although his own sensibilities may have suffered in the process. Moreover, his piano-playing showed the same taste and the same sensibility.”

At the end of his life he recovered his religious belief and practice in the company of Father Bruno de Jésus, a friend of Laforgue.

JEAN-PIERRE BOURGERON

See also: Clark-Williams, Margaret; Congress of French-speaking psychoanalysts from Romance-Language countries; France; Loewenstein, Rudolph M.; Société psychanalytique de Paris et Institut de psychanalyse de Paris.

### **Bibliography**

Parcheminey, Georges. (1932). L'hystérie de conversion. *Revue Française de Psychanalyse*, 5, 1, 106–140.

———. (1948). La problématique du psycho-somatique. *Revue Française de Psychanalyse*, 12, 2, 233–249.

Pichon, Édouard; and Parcheminey, Georges. (1928). Sur les traitements psychothérapeutiques courts d'inspiration freudienne chez les enfants. *Revue Française de Psychanalyse*, 2, 4, 711–720.

## **PARENTHOOD**

The term “parenthood” has acquired a semitechnical sense in anthropology and psychoanalysis, and it has the same connotations in both disciplines. Ethnologists began using the term in the 1970s (Goodenough, 1970; Carroll, 1970; Goody, 1971). It specifies one of three kinds of social relations that make up kinship: the relationship between parents and children (the other two kinds of kinship systems govern blood relations and relations by marriage).

The term “parenthood” also raises the issue of the child as “property.” To be recognized as a child’s parent, is it sufficient for a man to engender, or a woman to give birth to, the child? The English ethnologist Esther Goody, in her book *Parenthood and Social Reproduction: Fostering and Occupational Roles in West Africa* (1982), theorized about parenthood for the first time. She distinguished five groups of functions that individuals can or must take on in order to be considered as parents of children: (1) conceiving or engendering; (2) raising, feeding, protecting; (3) instructing, educating; (4) considering oneself responsible for what the child does; (5) endowing the child at birth with a status, a name, and a group of rights and duties. In different societies, these various functions may exist in combination or separately; adult responsibilities vis-à-vis the child are thus susceptible of broad variety of dissociation and division (the case of adoption is a classic example).

For psychoanalysis, parenthood consists of a process of psychic maturation that begins at conception for both mother and father. Therese Benedek (1973) and

G. Bibring-Lehner (1959, 1961), two American psychoanalysts, introduced the term “motherhood,” which they defined as all the affective processes that develop and are integrated in a woman when she becomes a mother. In France this notion was introduced by the psychiatrist Paul-Claude Racamier (1961).

In psychodynamic terms, insofar as motherhood is a mental process that cannot be reduced to physiology, the father too may be supposed to go through an identity crisis analogous to that of the mother. This is directly in line with the thinking of Therese Benedek, who showed that men and women share the same two sources of parenthood: their biological bisexuality and their common dependency on a mother or mother figure. Indeed, in men and women the urge to reproduce has a common origin (the pregenital stage); only its organization is different in each sex. Taking up a theme from “Totem and Taboo” (Freud, 1912–1913a), Theodor Reik, in his interpretation of the custom of *couvade* in “Die *Couvade* und die Psychogenese der Vergeltungsfurcht” (The *couvade* and psychogenesis of the fear of reprisals; 1914), emphasized that the attainment of fatherhood—the fulfillment of an oedipal wish—entails a thoroughgoing reorganization of the libido in men as well as in women. (*Couvade* is a custom where the father takes to bed during the birth of a child and submits to certain taboos.)

Some psychoanalysts have adopted the notion of fatherhood in connection with the psychoaffective changes that occur in fathers-to-be. Clinical experience has revealed that future fathers experience a normal crisis equivalent to that of motherhood (Carel, 1974; Delaisi de Parseval, 1981). Such crises, whose unpredictable outcome may have maturational value and may lead to a new equilibrium, should be understood by analogy with the classical psychoanalytical account of clashing instincts that eventually become integrated.

It is notable that in Western societies the lived experience of fatherhood is concealed, even denied, both in fantasy and on the psychosomatic level. These societies in effect promote an implicit ideology of parenthood in which essentially feminine moments such as pregnancy, giving birth, breast feeding, and the earliest relations between mother and infant are privileged as essential. The man, the father, remains a relatively unobtrusive presence in representations of parenthood.

GENEVIÈVE DELAISI DE PARSEVAL



*See also:* Archaic mother; Benedek, Therese; Infantile psychosis; Premature-Prematurity; Racamier, Paul-Claude; Tenderness.

### **Bibliography**

- Benedek, Therese. (1959). Parenthood as a developmental phase. *Journal of the American Psychoanalytic Association*, 7, 389–417.
- . (1973). *Psychoanalytic investigations: selected papers*. New York: Quadrangle Books.
- Delaisi de Parseval, Geneviève. (1981). *La part du père*. Paris: Seuil.
- Goody, Esther. (1982). *Parenthood and social reproduction: fostering and occupational roles in west Africa*. Cambridge, UK: Cambridge University Press.
- Racamier, Paul-Claude. (1961). La mère et l'enfant dans les psychoses du post-partum. *Évolution psychiatrique*, 4, 525–570.
- Reik, Theodor. (1914). Die Couvade und die Psychogenese der Vergeltungsfurcht. *Imago*, 3, 409–455.

### **Further Reading**

- Anthony, J., and Benedek, T. (Eds.). (1970). *Parenthood: Its psychology and psychopathology*. Boston: Little, Brown and Co.

---

**PARIS PSYCHOANALYTICAL SOCIETY.** *See* Société psychanalytique de Paris et Institut de psychanalyse de Paris

---

## **PARRICIDE**

“Murder of the father” is a reference to the murder of the legendary king of Thebes by Oedipus, the Greek hero in Sophocles’ play *Oedipus Tyrannus* (King Oedipus). According to Freud, we were all, as young children, gripped by the “compulsion” embodied in the Greek legend: we were all, “once, in germ and in fantasy, just such an Oedipus” (1950a [1892–1899], p. 265). Analysts speak of “parricide” when the fantasy is acted out, when the murder of the father is no longer merely an imagined infraction of one of the two oedipal injunctions. The term refers both to a willful act of murder of the father (or, more generally, of a male progenitor) and to the murderer.

Freud introduced the hypothesis of parricide in the fourth chapter of *Totem and Taboo* (1912–1913a). The word “Vatermord” (murder of the father) conveys an element of intent in the crime committed by the son. In the case of a premeditated murder by the primitive horde, the homicide in question might be considered a form of assassination. According to the Freudian myth, “one day, the brothers who had been driven out came together, killed and devoured their father and so made an end of the patriarchal horde” (1912–1913a, p. 141). In a single sentence Freud thus summed up the “memorable and criminal deed” (p. 142) that served as the foundation and chief precondition of psychoanalytic thought and “the main source of the sense of guilt” (1928b [1927], p. 183).

When Freud first used the term “Oedipus complex,” he spoke of the moment when the boy “begins to desire his mother . . . and to hate his father anew as a rival who stands in the way of this wish” (1910h, p. 171). The hostile impulses that the child develops toward his father are the mental correlate of fundamental biological facts, namely the “prolonged period of [humanity’s] dependence in childhood” (1940a [1938], p. 185), which inevitably leads to a conflict-ridden relationship with the parents. In *Totem and Taboo* (1912–1913a), Freud noted the adventitious content of the two oedipal crimes—the two prohibitions forming the core of totemism—and the child’s two primal wishes. The institution of a prohibition hid the fact that those who punished transgression harbor the same desire as the transgressor. This, for Freud, was “one of the foundations of the human penal system” (p. 72).

In 1927, in his introduction to a German book on Dostoevsky, specifically on *The Brothers Karamazov*, Freud observed that this novel was one of “three masterpieces of the literature of all time” to deal with the manslaughter of the father (*Vatertötung*). His choice of the term “Vatertötung,” which implies no criminal intent on the part of the son, enabled Freud to assert that in the Greek drama, “the hero commits the deed unintentionally” (1928b [1927], p. 188). In contrast, in the Russian novel, as in Shakespeare’s *Hamlet*, someone else commits the murder. Two years later, in *Civilization and Its Discontents* (1930a [1929]), Freud again insisted that it is impossible to get “away from the assumption that man’s sense of guilt springs from the Oedipus complex and was acquired at the killing of the father by the brothers banded together” (p. 131). However, to

account for the action of the death instinct, discovered in the interim, Freud now stressed the inevitability of the feeling of guilt as an “expression of the conflict due to ambivalence, of the eternal struggle between Eros and the instinct of destruction or death” (p. 132). It follows that whether or not the father is actually killed is of no great consequence.

In “Some Character-Types Met with in Psycho-Analytic Work” (1916d), Freud had argued that many criminals suffer from a sense of guilt. Such guilt may predate the crime, which is in fact perpetrated as a way of seeking punishment. This claim was clinically demonstrated and developed by other authors during the last decades of the twentieth century. Referring to the important notion of guilt, Jean Laplanche defined the oedipal crime as “the first crime committed out of a feeling of guilt” (1992). Sophie de Mijolla-Mellor, who thinks that the fantasy of murder enables the child to accept the idea of death, defends the hypothesis that murder is part of a “sexual theory of childhood” (1996). Paul-Laurent Assoun has pointed out the resonance between the primal criminal act of patricide and a particular criminal metaphor of the unconscious: the work of repression, he writes, is simply an “effort to erase the traces of a primal crime” (1997). The risks stemming from the unconscious and associated with crime—notably with the murder of the father—raise the issue of the relations between law and psychoanalysis.

For Freud, myth indicates the path every child will have to travel as an individual. Certainly, the legend of Oedipus provided him with an opportunity to “‘fictionalize’ a mental truth” (Assoun, 1997). The myth of the murder of the father of the horde arguably constitutes a kind of distillation of the Yahweh myth, which Freud called the “Christian myth” (1912–1913a) and Lacan called the “myth of the apple.” The hypothesis that the murder of the father is criminal is in fact well suited to accounting for the primal fault (Freud incorrectly referred to it as “original sin”), which can be understood as a tragic split between humanity and God the Father resulting from the human wish to usurp God’s place. The discovery of correspondences between the mental life of savages and that of the early Jews makes it possible to identify the hidden origins of the oedipal myth in the stories of Genesis. But above all, this Freudian myth serves to confirm the relevance and universal nature of the finding that Freud summed up in the axiom that where there is prohibition, there

is a wish. Original guilt implicates the subject not in the primal fault but in desire itself.

MARIE-DOMINIQUE TRAPET

*See also:* Castration complex; *Civilization and Its Discontents*; Civilization (*Kultur*); Cultural transmission; “Dostoyevsky and Parricide”; Ethics; Father complex; Fatherhood; *Hamlet and Oedipus*; Id; Law and psychoanalysis; *Moses and Monotheism*; Myth of origins; Oedipus complex; Organic repression; Phylogenesis; Primitive horde; Racism, anti-Semitism, and Psychoanalysis; Superego; *Totem and Taboo*; Transgression.

### **Bibliography**

- Assoun, Paul-Laurent. (1997). *Psychanalyse*. Paris: Presses Universitaires de France.
- Freud, Sigmund. (1910h). A special type of choice of object made by men. *SE*, 11: 163–175.
- . (1912–1913a). Totem and taboo. *SE*, 13: 1–161.
- . (1916d). Some character-types met with in psychoanalytic work. *SE*, 14: 309–333.
- . (1928b [1927]). Dostoyevsky and parricide. *SE*, 21: 173–196.
- . (1930a [1929]). Civilization and its discontents. *SE*, 21: 57–145.
- . (1940a [1938]). An outline of psycho-analysis. *SE*, 23: 139–207.
- . (1950a [1887–1902]). Extracts from the Flies papers. *SE*, 1: 173–280.
- Laplanche, Jean. (1992). *La révolution Copernicienne inachevée*. Paris: Abider.
- Mijolla-Mellor, Sophie de. (1992). *Le plaisir de pensée*. Paris: Presses Universitaires de France.
- . (1996). Le meurtre comme théorie sexuelle infantile. *Topique*, 59, 15–29.

### **Further Reading**

- Loewald, Hans W. (1979). The waning of the Oedipus complex. *Journal of the American Psychoanalytic Association*, 27, 751–776.

---

## **PARTIAL DRIVE**

When Freud spoke of “a drive,” he was always referring to a partial drive. The first definition of this term is

found in the first of the *Three Essays on the Theory of Sexuality* at the opening of section five, “Component [Drives] and Erotogenic Zones”: “By [a drive] is provisionally to be understood the psychical representative of an endosomatic, continuously flowing source of stimulation, as contrasted with a ‘stimulus,’ which is set up by *single* excitations coming from without. The concept of [drive] is thus one of those lying on the frontier between the mental and the psychical. The simplest and likeliest assumption as to the nature of [drives] would seem be that in itself [a drive] is without quality, and, so far as mental life is concerned, is only to be regarded as a measure of the demand made upon the mind for work. What distinguishes the [drives] from one another and endows them with specific qualities is their relation to their somatic sources and to their aims. The source of [a drive] is a process of excitation occurring in an organ and the immediate aim of the [drive] lies in the removal of this organic stimulus” (1905d, p. 168).

Freud quickly conceived of the role of the sexual drive and the libido in the etiology of the neuroses, but the discovery of infantile sexuality took much longer. According to the “seduction theory,” the effects of sexuality in the infant were extrinsic and contingent. Freud abandoned this theory when he discovered fantasy and the Oedipus complex during his self-analysis. In its place, there appeared a general infantile sexuality that gives rise to fantasies, neurotic symptoms, perverse acts, and delusions. According to his letters to Fliess, this work was accomplished between September 21 and November 14, 1897. The anal and oral regions and “perhaps the whole surface of the body as well” are sexual zones that in infancy “instigate something that is analogous to the later release of sexuality” (1950a [1892–99], p. 269). These zones persist in perversion, but usually fall under “normal repression.”

Fueled by both clinical observation and Freud’s own self-analysis, the elaboration of infantile sexuality is found throughout *The Interpretation of Dreams* (1900a). The analysis of Dora’s cough (1905e [1901]), reveals a fantasy of sucking the penis. The morphogenesis of the fantasy is simple: the mouth is the “primary erogenous zone”; created by the act of nursing, it survives in the act of kissing. “So we see that this excessively repulsive and perverted phantasy of sucking at a penis has the most innocent origin. It is a new version of what may be described as a prehistoric impression of sucking at the mother’s or nurse’s breast—an

impression which has usually been revived by contact with children who are being nursed. In most cases, a cow’s udder has aptly played the part of an image intermediate between a nipple and a penis” (1905e [1901], p. 52). Stating that “Psychoneuroses are, so to speak, the *negative* of perversions” (p. 50), Freud sketched out the thesis that he would establish in the *Three Essays on the Theory of Sexuality* (1905d). “You will have no doubt heard . . . that in psychoanalysis the concept of what is sexual has been unduly extended in order to support the theses of the sexual causation of the neuroses and the sexual meaning of symptoms. . . . We have only extended the concept of sexuality far enough to be able to comprise the sexual life of pervers and children. We have, that is to say, given it back its true compass” (1916–17a, p. 319).

The synthesis of these concepts began in 1905. So-called normal adult sexuality, neuroses, and perversions all show the sexual drive to be aberrant if reproduction is its aim. But these aberrations are effaced if the innate germs of sexuality go through a complex morphogenesis in infancy and then succumb to repression, which creates amnesias and an ignorance comparable to those found in neurosis. These germs of sexuality develop along with the physiological needs and functions, the points on the body that interface with the external world each creating their own organ pleasure. Thus the partial drives find their source, their aim, and their object, “the thing in regard to which the [drive] is able to achieve its aim. It is what is most variable about [a drive]” (1915c, p. 122). If a drive finds its object in the subject’s own body, it is described as autoerotic. Sadoomasochism and mastery involve oral, anal, urethral, and muscular erotism. Voyeurism and exhibitionism involve the eyes. As for the skin, the “erotogenic zone par excellence” (1905d, p. 169), it involves the genitals, among other regions. Meanwhile, the infant is “polymorphously perverse.”

From this point on, Freud worked continuously on the theory of the partial drives and their vicissitudes. He elucidated the transformations that the primitive impulses of the drive undergo on account of their entanglement in language in terms of the development of the ego, education, and culture. He described psychoanalysis as “biological psychology: “[W]e are studying the psychical accompaniments of biological processes” (1933a [1932], pp. 95–96).

Diligently following up his clinical work, Freud devoted himself in 1931 to analyzing the myth of

Prometheus: a story of the urethral drive, or rather of how humankind's control over fire, acquired by repressing the wish to urinate on it, led to legends (1932a).

In the unconscious, the impulses of the drive—the primary energy and material of mental processes—appear as both ideational representative and quota of affect. These impulses have both active and passive aims that make them susceptible to ambivalence. Several impulses can share the same vicissitude, and the satisfaction of one can replace that of another. These transpositions of drives give rise to unconscious concepts such as feces-infant-penis. And the ego's defenses alter the ways in which impulses are expressed. Reversal into the opposite, turning around upon oneself, repression, regression, reaction-formation, isolation, undoing, projection, inhibition as to aim, and sublimation all testify to the malleability of drives. Moreover, infantile development goes through the stages of pregenital libidinal organization, which involve the choice of an object and the primacy of the partial drives: oral, anal-sadistic, and then phallic. These stages converge in the formation of character and can provoke regressions. Also, it is worth noting that all fantasy scenarios include the satisfaction of a drive.

The notion of the partial drive has given rise to more elaborations than criticism. For example, Karl Abraham, Sándor Ferenczi, and Lou Andreas-Salomé all added to the theory, as did the development of child analysis.

MICHÈLE PORTE

*See also:* Autoeroticism/alloeroticism; Breast, good/bad object; Character; Drive; Eroticism, anal; Exhibitionism; Libidinal development; Object (*a*); Organ pleasure; Organization; Pleasure in thinking; Scopophilia/scopophilia; Sexuality; Skin; Stage.

### **Bibliography**

Freud, Sigmund. (1950a [1892–99]). Extracts from the Fliess papers. *SE*, 1: 177–280.

———. (1905e [1901]). Fragment of an analysis of a case of hysteria. *SE*, 7: 1–122.

———. (1915c). Instincts and their vicissitudes. *SE*, 14: 109–140.

———. (1916–17a). Introductory lectures on psycho-analysis. *SE*, 15–16: 15–463.

———. (1933a [1932]). New introductory lectures on psycho-analysis. *SE*, 22: 1–182.

———. (1905d). *Three essays on the theory of sexuality*. *SE*, 7: 123–245.

Lacan, Jacques. (1978). *The four fundamental concepts of psychoanalysis*. (Alan Sheridan, Trans.) New York: W. W. Norton. (Original work published 1964)

---

## **PASCHE, FRANCIS LÉOPOLD PHILIPPE (1910–1996)**

Francis Pasche, physician, psychiatrist, psychoanalyst, and full member of the Paris Psychoanalytic Society, was born in Paris on May 7, 1910, and died there on September 12, 1996.

His mother came from the Champagne region and his father from Switzerland. He was educated to be an atheist but was inculcated with moral principles that were imbued with Jansenist rigidity and Calvinist rigor.

In 1928–29 he began to study pharmaceuticals and graduated in 1934. In 1935 he completed his military service as an auxiliary pharmacist near Dole in the east of France. He had a simultaneous and passionate involvement with philosophy and esthetics. He thus began to work toward a primary degree in philosophy at the Sorbonne. His mentors were Victor Basch and Charles Blondel. He studied the great historians of philosophy from the 1930s: Henri Gouhier, Victor Brochard and Étienne Gilson.

His interest in psychoanalysis dates from the time when he began to study philosophy. Pasche had completed his first two years of medical studies when World War II broke out in 1939. He was mobilized as an auxiliary pharmacist at Vesoul on September 15, 1939. On November 20 he was posted to the Rouffach emergency unit. Imprisoned at Gérardmer on June 22, 1940, he was sent to Stalag II B.

As a member of the health services, he was allowed to return to France on January 28, 1941 and was posted to different Parisian hospitals. He was still a military prisoner, but under particularly favorable conditions that enabled him to complete his medical studies. He graduated in 1944. The Medical Faculty of the University of Paris awarded him a bronze medal for his thesis, conducted under Jean Delay and titled “Psychopathologie du cauchemar” (The psychopathology of the nightmare). In 1948 he was appointed director of the clinical laboratory for mental diseases. The French Medical Association officially recognized him as a psychiatrist in

1951 and as a neuro-psychiatrist in 1953. In 1961 he was appointed assistant consultant at the Sainte-Anne psychiatric center. He continued to work there for more than thirty years training young psychiatrists and as a consultant. His reputation crossed the Atlantic and many Canadians and Latin Americans came there to study under him.

Having been analyzed by John Leuba, he quickly became a member of the Paris Psychoanalytic Society. He was made a full member in 1950 and was president of the society from 1960 to 1964. He therefore witnessed the rift that took place in 1953, a rift that toward the end of his life he believed could have been avoided. In 1959 he married Maria Cléopas, a Greek woman, with whom he had two sons, Alexandre and Jérôme. Francis Pasche was a man of books and culture and for many years he directed a seminar at the Institute of Psychoanalysis: he discoursed with equal ease on philosophy, anthropology, metapsychology, and clinical practice.

To appreciate the full value of some of his writings, they should be read in counterpoint with those of Lacan, a man he both admired and criticized and with whom he had a fascinating but difficult relationship. His work comprises a large number of articles and papers for colloquia and national and international congresses. Some of it has been brought together in two volumes: *À partir de Freud* (Beginning with Freud; 1969), and *Le Sens de la psychanalyse* (The meaning of psychoanalysis; 1983). He made important and original contributions to the clinical treatment of the psychoses, and the theory and clinical treatment of depression. Equally remarkable are his writings on anxiety, the notion of the superego, the issues at stake in analysis, psychoanalytic ethics, and the role of the analyst. His deeply philosophical nature also led him to take an interest in Greek mythology and in the religions of the book.

MICHÈLE BERTRAND

*See also:* Congress of French-speaking Psychoanalysts from Romance-language Countries; Counter-Oedipus; Excitation; France; Narcissistic neurosis; Société psychanalytique de Paris et Institut de psychanalyse de Paris; Spinoza and psychoanalysis.

### **Bibliography**

Pasche, Francis. (1969). *À partir de Freud*. Paris : Payot.

———. (1983) L'imaginaire. *Revue Française de Psychanalyse*, 47, 4, 939–952.

———. (1988). Travail de construction ou, si l'on préfère, de reconstruction. Construction et reconstruction. *Bulletin de la Fédération Européenne de Psychanalyse*, 31, 19–31.

———. (1993). Mères archaïques et subjectivation. *Devenir*, 5, 4, 67–77.

———. (1996) Peur de la mort, angoisse de mort, défense du Moi. *Revue Française de Psychanalyse*, 60, 1, 49–53.

---

## **PASS, THE**

Lacan invented the pass to clarify and formalize the transition between analysand and analyst: “This dark cloud that covers this juncture I am concerned with here, the one at which the psychoanalysand passes to becoming a psychoanalyst—that is what our School can work at dissipating” (Lacan, 1995).

Lacan's foundation of the École freudienne de Paris (Freudian School of Paris) on June 21, 1964, was marked by the originality of its membership categories. No longer were there permanent members or didacticians, since an analysis could be recognized as didactic only after the fact by the analysand in question becoming an analyst. There were three categories of membership: analyst of the school (a title initially given to all the former permanent members of the Société psychanalytique de Paris [Paris Psychoanalytic Society] and the Société française de psychanalyse [French Society of Psychoanalysis]), member analysts of the school (who were nominated by a reception committee that guaranteed the “competence” and “regularity” of the candidate's analytic practice), and practicing analysts (who declared their own practice to be analytic, although it was not guaranteed by the school).

Internal conflicts soon developed within the school over training and clinical ability. In an attempt to overcome this crisis, François Perrier proposed, on March 31, 1967, in an address to the analysts of the school, the formation of a college of analysts of the school, which would be devoted to “the clinic as a career and a vocation” (1994). This initiative did not receive any support from Lacan, who wrote up an alternative plan under the title “Proposition of 9 October 1967 on the psychoanalyst of the school” (1995). The procedure that Lacan proposed involved having a candidate give an account of an analysis in which the candidate was the analysand before three “passers,” who had been

nominated by their own analysts. The passers would then report about their sense of the analysis to an acceptance committee, which could then allow the candidate to pass from analysand to analyst.

This initiative gave rise to a lively debate within the school. As early as 1968, Piera Aulagnier, Maud Manoni, François Perrier, and Jean-Paul Valabrega made their objections known (later published in *Analytica*, 7 [1978]). And when Lacan put the proposal to a vote for inclusion in the school's statutes during the Lutetia (Paris) session, Piera Aulagnier, François Perrier, and Jean-Paul Valabrega resigned from the school.

Nevertheless, the pass was put into practice. It seemed that Lacan expected the pass to be not an "experiment in unconscious knowledge," but a "revelation." Thus the pass had nothing to do with analysis. In 1974, in a letter to three of his Italian adherents (Giacomo Contri, Muriel Drazien, and Armando Verdiglione), Lacan recommended that they create an Italian group, "including the principle of the pass for those who apply for it" (1982). In Italy the pass was thus proposed at the outset before the school was functioning.

On January 7 to 8, 1978, during the Deauville session on the pass experiment, Lacan heard much discussion on the value of the pass. He mostly heard objections to the procedure, notably from Ginette Raimbault and Serge Leclaire. So he closed the session with these words: "I had wanted to hear testimonials about how it's working. And obviously I didn't hear any. The pass really is a complete failure" (*Lettres de l'école*, April 1978).

Lacan's declaration that the pass was a failure seemed to indicate that it is impossible to pinpoint within the analytic situation the passage from analysand to analyst. Thus analysts must resort to the other way of recognizing a psychoanalyst, namely an ability to maintain the analytic position as verified by a supervised analysis. This leads to the hypothesis that one is an analyst only in the analytic situation.

JACQUES SÉDAT

*See also:* École de la Cause freudienne; École freudienne de Paris; France; Quatrième Groupe (O.P.L.F.), Fourth group; Training analysis; "Unconscious, The."

### **Bibliography**

Lacan, Jacques. (1970). Discours prononcé par J. Lacan le 6 décembre 1967 à l'École Freudienne de Paris. *Scilicet*, 2–3, 9–29.

———. (1977). *Sur la passe. Ornica?* 12–13.

———. (1982). Note italienne. *Ornica?* 25, 7–10.

———. (1995). Proposition of 9 October 1967 on the psychoanalyst of the school. (Russell Grigg, Trans.). *Analysis*, 6, 1–13. (Original work published 1968)

Perrier, François. (1994). *La chaussée d'Antin* (new ed.). Paris: Albin Michel.

---

## **PASSION**

Passion is the abandonment of the ego to an object (a person or abstract idea) that has taken the place of the ego ideal. The relationship is one of alienation, wherein the object of desire has become an object of need.

Although Freud made frequent references to passion—individual or collective—throughout his work, he did not distinguish it from the state of being in love, which for him found its extreme manifestation in passion. Subsequently, other authors examined the specific characteristics of this state, which resembles addiction in some respects.

In passion the psychoanalyst encounters both philosophical and psychiatric elements. Plato, in the Phaedrus, described the phenomenon as a burning condition, where the soul separates from the body. Marsilio Ficino saw the "divine fury" as an illumination of the soul, and Giordano Bruno saw in the "heroic fury" the alienation in which self-consciousness vanished. Hegel claimed that "nothing great is accomplished without passion." Similarly, Freud referred to the passionate abandonment to an abstract idea or ideal, even to research, as he found in Leonardo da Vinci (1910c)—and in himself.

The states of passion studied by psychiatry resemble paranoia more than love (Clérambault). Freud distinguished three types of passion: the passion that arises from being in love, the passion that corresponds to the cathexis of a sublimated activity, and the passion that has more in common with hate than with love (erotomania).

Concerning the passion associated with being in love (1921c), it is the degree of idealization of the object and the corresponding weakening of the ego that leads to the submissiveness of the subject. Freud used a model of the hypnotic relationship to describe the crowd's subjugation to its leader: "A primal horde

is the sum of individuals who have put a single object in place of their ego ideal and consequently, in their ego, have identified with one another." Freud's study of the *Gradiva* is situated at the border between love cathexis and passionate investment in an abstraction (1907a). The "delusion" consisted precisely in substituting the latter (the archeological revivification) for the living young girl whom the hero no longer recognizes. From the repressed memory to fantasy and delusion, there is a sense of continuity, similar to what Freud had found between love and passion.

The passionate cathexis of a sublimated activity is caused by a transposition, a redirection of drive. Leonardo, "having transposed his passion into the thirst for knowledge, now abandoned himself to the investigation with the tenacity, continuity, and penetration that are associated with passion" (1910c). The origin of the disposition to passion may relate to the intensity of the erotic relationship between mother and child ("My mother crushed my mouth with countless kisses," wrote Leonardo). In "Observations on Transference Love" (1915a [1914]), Freud associated the tumultuous passion of the patient for the analyst with resistance. Aside from the technical issue, he goes on to point out that this apparent abandonment to love is in fact a demand without any basis in reality. Those patients "would like, with their passion disconnected from any social bond, to keep the doctor at their mercy." This relation of subjugation, compared by Freud to the dangerous manipulation of explosive substances, is closer, in spite of his claims, to an erotomaniacal form of paranoia than to the state of being in love, even when intense.

Sándor Ferenczi spoke of the "language of passion" as opposed to "tenderness" (1932), emphasizing the traumatic force of the confusion of tongues between adults and the child, ranging from sexual rape to erotic punishment. He emphasized the "premature graft of the varieties of erotic love loaded with feelings of guilt onto an individual who is still immature and innocent." Years later, Daniel Lagache (1947) examined from a psychoanalytic viewpoint the clinical treatment of states of passion (jealousy, erotomania).

Piera Aulagnier (1979) developed a new approach to the concept of passion, which she defined as "a relation in which an object has become, for the I, another exclusive source of all pleasure and has been displaced in the hierarchy of needs." There are three prototypes for this: the relation of the drug addict to the drug, the

relation of the gambler to the game, the relation of an other to the I, that is, "amorous passion," which is qualitatively and not quantitatively different from being in love. Characterized by an asymmetry between the two partners, where one appears as unattainable, the personal relation assumes a desire for subjugation supported by an "inductor," or passion instigator, which uses the suffering of the other to control emotions.

Literature provides invaluable support for extending the psychoanalytic study of passion. In it can be found constant elements such as the fantasy of an opaque and explosive body, the negation of the natural rhythm of time, which is always present in its instantaneity, and the infinite extension of space in the representation of a fusion that is always situated in the future. The impassioned individual struggles to counter-cathect an impossible mourning and, more profoundly, to realize an absent narcissistic unity. The vital question embodied by passion is well illustrated in crimes of passion (Mijolla-Mellor, Sophie de, 1987).

SOPHIE DE MIJOLLA-MELLOR

*See also:* Alienation; "Confusion of Tongues between Adults and the Child, the Language of Tenderness and Passion"; Delusion; "Dostoevsky and Parricide"; Erotomania; Freud, the Secret Passion; Idealization; Group Psychology and the Analysis of the Ego; *Leonardo da Vinci and a Memory of his Childhood*; Love; Narcissistic elation; Negative therapeutic reaction; Tenderness.

### Bibliography

- Aulagnier, Paula. (1979). *Les Destins du plaisir. Aliénation, amour, passion*. Paris, Presses Universitaires de France.
- Freud, Sigmund. (1907a [1906]). Delusions and dreams in Jensen's "Gradiva." *SE*, 9: 1–95.
- . (1910c). Leonardo da Vinci and a memory of his childhood. *SE*, 11: 57–137.
- . (1915a [1914]). Observations on transference love (further recommendations on the technique of psychoanalysis III). *SE*, 12: 157–171.
- . (1921c). Group psychology and the analysis of the ego. *SE*, 18: 65–143.
- Lagache, Daniel. (1981). *La Jalousie amoureuse: psychologie descriptive et psychanalyse*. 2d. ed. Paris: Presses Universitaires de France. (Original work published 1947)
- Mijolla-Mellor, Sophie de. (1987). Le phénomène passionnel. *Dialogue*, 96.

## PAYNE, SYLVIA MAY (1880–1976)

Sylvia Payne, British physician, psychiatrist, and psychoanalyst was born on November 6, 1880 in Wimbledon, Surrey, England. She died on July 30, 1976 in Tunbridge Wells, Sussex, England.

Payne was the daughter of a clergyman and one of nine siblings. She went to Wimbledon High School. At thirteen she had taken the exams to enter a Musical College, but after her teacher died, she decided to study medicine instead. She trained at Westfield College and the London School of Medicine for Women (Royal Free Hospital). She qualified in 1906. In 1908 she married a surgeon, J. E. Payne, with whom she had three sons. During the 1914–1918 War she was Commandant and Officer in Charge of the Torquay Red Cross Hospital, and for her services there she was appointed CBE, (Companion of the order of the British Empire) in 1918.

It was while working with shell-shocked patients that she first heard about Freud's work. She started analysis in London with James Glover. In 1920 she went to Berlin to have analysis with Hanns Sachs. While there she learned enough German to read Freud's *Ego and the Id* for herself. She returned to London and was elected an Associate Member of the British Society on June 1922. She was elected a full Member in October 1924. Her husband, who was a general practitioner, sent her patients. She was thus independent of Jones or Glover for referrals. She held many important offices in the Society and was a trusted administrator and colleague. In 1926 she joined the staff of the London Clinic of Psychoanalysis and was Honorary Secretary of it until 1937. In 1927 she was elected to the Training Committee, on which she served for many years. In 1929 she replaced Rickman as Secretary of the Institute of Psycho-Analysis, and she was elected Business Secretary of the Society. As such she was responsible for arranging for the typed record of the Controversial Discussions that took place during the Second World War. She was elected President of the British Society in 1944, following the controversies. As president, she played an important role in facilitating the rapprochement between Anna Freud and the British Society in 1946, which resulted in a revised training scheme that offered two parallel training courses. She was again elected President of the Society from 1954–1956, during the Freud Centenary Celebrations. In 1962 she was elected an Honorary Member of the Society.

Payne did not publish many papers, but read fourteen papers to the British Society. These cover clinical problems, combining Freud's conceptual framework with her concern for training issues.

She believed that psychoanalysis flourished in an atmosphere of scientific controversy, and although a "moderate," she always valued contributions from colleagues from different theoretical orientations. It is largely due to her that there is one united psychoanalytical society in Britain today.

PEARL H. M. KING

*See also:* British Psycho-Analytical Society; Controversial Discussions; Feminism and psychoanalysis; Great Britain; Tavistock Clinic.

### Bibliography

- Payne, Sylvia M. (1935). The conception of femininity. *British Journal of Medical Psychology*, 15, 18–33.
- . (1939). Some observations on the ego development of a fetishist. *International Journal of Psycho-Analysis*, 20, 161–170.
- . (1943a). Contribution to the discussion of the fundamentals of technique. In King, Steiner (Eds.): *The Freud-Klein controversies 1941–1945*. (p. 648–652). London: Institute of Psycho-Analysis-Routledge, 1991.
- . (1943b). The principles and methods of the training of child psychoanalysts. *International Journal of Psycho-Analysis*, 24, 61–63.
- . (1946). Notes on the theory of psycho-analytical therapy and its connection with the theory of technique. *International Journal of Psycho-Analysis*, 27, 12–19.

## PENIS ENVY

The little girl notices the strikingly visible and well-proportioned penis of a brother or playmate, immediately recognizing it as the superior counterpart of her own small and hidden little organ and from then on she is subject to penis envy. She has seen it, knows that she does not have it, and wants it. This is the way Freud describes penis envy in *Some Psychological Consequences of the Anatomical Distinction between the Sexes* (1925j).

The first allusion to envy in relation to the penis appears in *On the Sexual Theories of Children* in 1908; the little girl then declares "that she would rather be a



boy.” Freud uses the term *Penisneid* for the first time in *Observations and Analyses Drawn from Analytical Practice* (1913h). He uses it again in *On Narcissism* in 1914. It constitutes the girl’s castration complex whereas anxiety concerning the penis constitutes the boy’s castration complex. The castration complex leads to “masculine protest,” a term invented by Adler and which he attached to ego instincts and not to sexual instincts.

In *The Sexual Theories of Children* (1908c), Freud says that the little girl would rather be a boy but then the accent is put, not on the situation of boys in general, but on the possession of the male sexual organ in itself. The girl reproaches her mother with not having given her one and turns away from her to take the father as a love object. Penis envy and the castration complex thus bring her into the Oedipus complex out of which, unlike the boy, she will never emerge (cf. *The Dissolution of the Oedipus Complex*, 1924d). The desire for a penis is replaced by the desire for a child by the father. But, whereas the boy identifies with the rival and forbidding father and thus constitutes a solid superego, the girl does not manage to produce a superego of the same quality. The result is a series of feminine characteristics: the woman “displays a lesser sense of justice, a lesser inclination to submit herself to the great necessities of life,” “she more often allows herself to be guided in her decisions by tender and hostile sentiments.” In short, we must not allow ourselves “to be misled by the argumentations of feminists who want to impose on us a complete parity of position and appreciation between the sexes.”

Freud’s position is linked to his phallocentrism and he failed to assess the degree to which it derived from the patriarchal culture in which he lived. He studied only the case of boys in depth and deducted from it, *mutatis mutandis*, conclusions concerning girls. He could not conceive of women except in negative terms: in order to become a woman, a man would have to renounce his penis. He was unable to conceive of women in a positive manner, as equipped with organs in which the man is lacking. He could conceive that a man might be afraid of women who want to take his penis from him. He could not conceive of men desiring femininity, maternity, or breasts. Women could have the fantasy of being no more than castrated men. Freud asserted that the castration of women was a reality that they had to accept. He thus forced them into a

feeling of inferiority from which it is difficult to see a way out.

Children of both sexes are subjected to trauma when they learn that, whether boy or girl, neither one is the totality of the human being. Each one relies on their peer group for self-valorization and to devalorize the other. It is in this more general framework that we must situate castration anxiety and penis envy. Penis envy does not consist in wanting to change sex but fits into the narcissistic continuity: the girl would like to have the narcissistic and social advantages linked with the possession of a penis, rather than the organ itself (Horney, 1922), especially if she has the experience of her father and mother putting more value on the male child.

COLETTE CHILAND

*See also:* Biological bedrock; Castration complex; Envy; Feminine sexuality; Feminism and psychoanalysis; Femininity; Femininity, refusal of; *New Introductory Lectures on Psychoanalysis*; Oedipus complex; Pregnancy, fantasy of; Phallic mother; Phallic stage; *Psychology of Women, The. A Psychoanalytic Interpretation*; Puerperal psychoses; “Some Psychological Consequences of the Anatomical Distinction between the Sexes”; Wish for a baby.

### **Bibliography**

- Freud, Sigmund. (1908c). On the sexual theories of children. *SE*, 9: 205–226.
- . (1913h). Observations and analyses drawn from analytical practice.
- . (1925j). Some psychical consequences of the anatomical distinction between the sexes. *SE*, 19: 241–258.
- . (1932a). The acquisition and control of fire. *SE*, 22: 183–193.
- . (1933a [1932]). New introductory lectures on psycho-analysis, *SE*, 22: 1–182.
- Horney, Karen. (1967). *Feminine psychology*. New York: W.W. Norton. (Original work published 1922)

### **Further Reading**

- Grossman, William I., Stewart, Walter A. (1976). Penis envy: From childhood wish to developmental metaphor. *Journal of the American Psychoanalytic Association*, 24, 193–212.
- Kirsten Dahl, E. (1996). The concept of penis envy revisited: A child analyst listens to adult women. *Psychoanalytic Study of the Child*, 51, 303–325.

## PERALDI, FRANÇOIS (1938–1993)

François Peraldi, Canadian psychoanalyst and professor of psychoanalysis in the Department of Linguistics of the University of Montreal, was born on May 2, 1938, in Paris, and died in Montreal, on March 21, 1993. The son of Jean Peraldi and Denise Roger, François was the second child of a family of three boys. He was proud of his father's heritage as a Corsican mountagnard peasant. He attributed his close ties to his father to the double pneumonia he contracted when he was eighteen months old, which required constant care from his father for three months. When his father was mobilized in 1939, he lost the person he loved most in the world. "My first mother," he wrote, "was not my mother, but my father."

After studying medicine Peraldi turned to psychoanalysis, and underwent a teaching analysis with Simone Decobert, an analyst with the Société Psychanalytique de Paris (SPP) (Paris Psychoanalytic Society). After being rejected by the SPP, he was accepted by the École Freudienne de Paris (Freudian School of Paris), where he completed his training. During this period, Peraldi developed friendships with Françoise Dolto, Luce Irigaray, and Michèle Montrelay. Interested in child psychoanalysis, he began working as an institutional psychotherapist with young psychotics. Along with his psychoanalytic training, he completed a doctorate in linguistics with Roland Barthes.

In 1974 he emigrated to Montreal, where he practiced psychoanalysis until his death at the age of fifty-five. Peraldi claimed that what he called the "intellectual terrorism" then practiced in France had driven him from the country. His training in linguistics and psychoanalysis, which led to a teaching position in the Department of Linguistics at the University of Montreal, had made him receptive to the work of Jacques Lacan. Although Peraldi actively promoted Lacan's work, he himself refused to be labeled a Lacanian.

A gifted thinker, Peraldi introduced Lacan's clinical work into North America, where Lacan's influence had been limited to philosophy and aesthetics. To remedy this Peraldi created the Peraldi seminar, attended by intellectuals, clinical practitioners, and apprentice analysts of all persuasions and loyalties. The seminars were given for fifteen years, from 1976 to 1991, and were held every other Wednesday at the university. Attendees listened to presentations by Julien Bigras,

Josette Garon, Jean Imbeault, Mireille Lafortune, Jacques Mauger, Lise Monette, Régine Robin and other local practitioners, as well as by Jacques Hasoun, Françoise Dolto, Luce Irigaray, Chantal Maillet, Gérard Miller, Gérard Pommier, and Moustapha Safouan. Several of the speakers from Montreal were members of the Montreal Psychoanalytic Society and Peraldi developed close ties with some of them. His friendships with the local psychoanalytic community led to his contributions to the review *Interprétation*, edited by Julien Bigras. He also became a member of the editorial committee of *Frayages* and contributed to *Filigrane*, edited by Hélène Richard.

Because of his opposition to any form of institutionalization, in 1986 Peraldi established the Réseau des Cartels, an idea he had borrowed from Lacan, being careful to emphasize that he was not founding an institution. To the extent that its only function was to promote the transmission of psychoanalysis rather than become a recognized training school, the Réseau served as an alternative to the institutional framework. "This network," he noted, "is a place for exchange and analysis, without any power of recognition or control." He succeeded in obtaining, for a psychoanalytic fringe that rejected any form of institutionalization, a framework for meetings and exchanges in small groups of four—"three plus one"—to discuss clinical problems, the analyst's desire, and the group unconscious.

He used to joke that Lacan's ideas had helped him become an analyst and read Freud but that he was more Lacanizing than Lacanian. He was an original, if marginalized, thinker, who rejected leaders of all kinds, but he was more than an interpreter of Lacan's work, and developed his own approach to Lacanian ideas. For example, he developed a personal approach to sexuality, which he developed in his 1981 article "Polysexuality."

Because of his early death much of the work intended for his seminar remained incomplete, but the seminars themselves remained a focal point for independent psychoanalysts in Montreal. His work as a consultant to many other analysts also remained unfinished, and the Réseau des Cartels was disbanded after his death.

JACQUES VIGNEAULT

*See also:* Canada; *Interprétation*; Lacan, Jacques.

### Bibliography

- Hazan, Marie. (1994). Transmission, filiation et institution psychanalytique. Rencontre avec François Peraldi. *Fili-grane*, 3, 135–161.
- Peraldi, François. (1981). Polysexuality. *Semiotex*, 4, 1, 167–170.
- . (1981–91). Séminaires sur les premières années de l'œuvre de Lacan. <http://www3.sympatico.ca/jbeili>.
- . (1987). La marge psychanalytique. *Frayages*, 3, 127–136.
- . (1991). L'expérience du silence. *Texte*, 10, 189–219.

## PERCEPTION-CONSCIOUSNESS (PCPT.-CS.)

In the Freudian metapsychology of the period of the first topography, the “Perception-Consciousness System” designates the system located on the periphery of the psychic apparatus. Its function is consciousness, and Freud linked it to the preconscious system.

The theoretical constitution of the Pcpt.-Cs. (Perception-Consciousness) system dates from the time of the “Project for a Scientific Psychology” (1950c [1895]). Gradually the Pcpt.-Cs. system was assimilated into the ego, or at least considered as its “core.” Two clearly demarcated systems were needed to explain two contradictory functions—the inscription of (lasting) mnemonic traces and their renewal—and this is what led Freud, following Breuer’s observations, to distinguish between the Ucs.-Pcs. and the Pcpt.-Cs.

From the topographical point of view, the Pcpt.-Cs. system is attached to the Pcs. (preconscious) system but not to the Ucs. (unconscious) system—at least, not to the unconscious as an effect of repression, since Freud considers the unconscious of a consequence of the ego. Because consciousness belongs to the ego, which is in part unconscious in the expanded sense of the term (the ego manifests unconscious energy in resisting the transformation of its unconscious into consciousness), the Pcpt.-Cs. system is topographically related to the unconscious of the ego, which, unbeknownst to itself, has “overdetermined” the ego’s operations. The Pcpt.-Cs. system receives information externally as well as internally, which is provisionally inscribed on its surface. The preconscious involves the mnemonic alteration and fixation of verbal traces and conscious perceptions. Conscious perceptions are current and immediate, while verbal representations

“were at one time perceptions” (1923b, p. 20). Furthermore it is because they are past perceptions that “they can become conscious again.” Freud explained in *The Ego and the Id* (1923b) that principally it is acoustic perceptions and not visual perceptions that constitute a “special reserve for the use of the preconscious,” “so that the system Pcs, has, as it were, a special sensory source,” images not being very suitable for making “thoughts” conscious. On the other hand, the unconscious makes much use of images, which can symbolize thought in the absence of sensory information, and without these thoughts being manifest.

From the economic point of view, the Pcpt.-Cs. system poses a particular difficulty in that it causes a transformation in perception itself. It presupposes a hyper-cathexis on the level of energy (or quantity), and it adds a special qualitative dimension with the establishment of an “index of reality.” Attention describes the process of making perceptions conscious not as a simple focusing, since perception is already focusing, but as a hyper-cathexis causing an “intensive” transformation of the perceived into a qualitative given. Though Freud does not say it explicitly, we can see that the perceived would become, through the workings of the Pcpt.-Cs. system, a “determination”—that is to say, a qualified relation of the ego to reality, which obliges the ego in turn to assume a position. In *An Outline of Psychoanalysis* (1940a [1938]), Freud specified that these “positions” are so many “*characteristics of the ego*. . . the ego has voluntary movement at its command. It has the task of self-preservation. As regards *external* events, it performs that task by becoming aware of stimuli, by storing up experiences about them (in the memory), by avoiding excessively strong stimuli (through flight), by dealing with moderate stimuli (through adaptation), and finally by learning to bring about expedient changes in the external world to its own advantage (through activity). As regards *internal* events, in relation to the id, it performs that task by gaining control over the demands of the instincts, by deciding whether they are to be allowed satisfaction, by postponing that satisfaction to times and circumstances favourable in the external world or by suppressing their excitations entirely. . . . The ego strives after pleasure and seeks to avoid unpleasure” (pp. 145–46), which the id does not know how to do, with the result that the ego is sensitive to anxiety, being capable of reading its signals. Finally:

“From time to time the ego gives up its connection with the external world and withdraws into a state of sleep” (p. 146). It should be mentioned in this connection that Freud did not recognize the activity of thought as one of these possible positions of the ego in relation to reality, even though he always stressed the importance of attention in thought processes.

Finally, from a dynamic point of view, Freud’s ideas about the Pcpt-Cs. continued to evolve. In the beginning he claimed that it controlled repression, which suggested that Pcpt-Cs. was based on a voluntarist conception of consciousness. Gradually, defenses and resistances were themselves linked, at least partly, to the unconscious of the ego, so that the “decisions” of the ego were no longer considered as the conclusions of attention, and the will was no longer envisaged as something that attention could control. Consequently attention itself was over-determined, and the Pcpt-Cs. system no longer possessed within itself the means for exploiting its dynamics. Ultimately, the strengthening of the Pcpt-Cs. system, which psychoanalysis attempts to accomplish, according to Freud, means that analytical work should be understood not only as an active transmutation of the Ucs. into the Pcpt-Cs., but also as a working-through of the unconscious that belongs to the ego itself—which is precisely what limits the activity of the Pcpt-Cs. system.

DOMINIQUE AUFFRET

*See also:* Agency; *Ego and the Id, The*; Lifting of amnesia; Protective shield; Surrealism and psychoanalysis.

### **Bibliography**

- Freud, Sigmund. (1923b). The ego and the id. *SE*, 19: 1–66.
- . (1925a [1924]). A note upon the “mystic writing pad.” *SE*, 19: 225–232.
- . (1940a [1938]). An outline of psycho-analysis. *SE*, 23: 139–207.
- . (1950c [1895]). Project for a scientific psychology. *SE*, 1: 281–387.

## **PERCEPTUAL IDENTITY**

The Freudian notion of perceptual identity refers to the goal pursued by the pleasure-seeking primary process by means of hallucination. Perceptual identity is

opposed to thought identity, which thought seeks by means of the secondary process.

The notion of perceptual identity is essentially articulated in Freud’s “Project for a Scientific Psychology” (1950c [1895]) and *The Interpretation of Dreams* (1900a). Yet the clinical, developmental, and anthropological dimensions of Freudian thought help one to grasp its full import, beyond the defining opposition between primary and secondary processes. Indeed, the issue of perceptual identity brings into play that of hallucination, which is fundamentally related not only to psychopathology but also to analytic clinical practice as such.

By means of hallucination, the primary process seeks to forestall any schism between the id and reality, and so it seeks to neutralize the ego, since the task of the latter is to negotiate the inevitable conflicts between the two. Perceptual identity presupposes a foreclosure of meaning in the sense in which Jacques Lacan discussed it, a result of the identity, in representation or affect, between the aim of the drive and perception. In melancholia, perceptual identity unifies the absent or lost object and the aim of perception; this permits a substitution of the past for the present and future, and preserves the lost object as a substitute satisfaction. By contrast, thought identity presupposes an elaboration of the lost object—hence the detour inherent in the activity of thought.

Cogitative thought processes may seek thought identity in perceptual identity. The great mystics demonstrate this, as do intuitionist currents in philosophy (for example, intellectual intuition in German idealism). Perhaps perceptual identity enhances speed of thought and gives rise to flashes of brilliance, whose importance to creativity should not be underestimated.

DOMINIQUE AUFFRET

*See also:* Experience of satisfaction; Pleasure/unpleasure principle; Infantile omnipotence; Mnemic trace/memory trace; Thought identity; Wish, hallucinatory satisfaction of a.

### **Bibliography**

- Freud, Sigmund. (1950c [1895]). A project for a scientific psychology. *SE*, 1: 281–387.
- . (1900a). The interpretation of dreams. *SE*, 4: 1–338; 5: 339–625.

Lagache, Daniel. (1982). La psychanalyse et la structure de la personnalité. In his *Ceuvres complètes*, Vol. 4, 1956–1962. Paris: Presses Universitaires de France.

Mijolla-Mellor, Sophie de. (1992). *Le plaisir de pensée*. Paris: Presses Universitaires de France.

## PERESTRELLO, DANILO (1916-1989)

Daniilo Perestrello, the Brazilian psychiatrist, psychoanalyst, and university professor, was born in Rio de Janeiro on February 28, 1916, and died there on February 10, 1989.

Perestrello practiced as a general practitioner for the first few years of his working life before becoming a psychiatrist. Late in 1946 he left for Buenos Aires in order to train as a psychoanalyst. When he returned to Brazil in 1949 he was already an associate member of the Asociación Psicoanalítica Argentina (APA) and became a full member in 1953. At the International Congress of Psychoanalysis held in London in 1953, Perestrello was the only Brazilian to present work that was published in the *International Journal of Psycho-Analysis*. In 1957 he was one of the founders of the Sociedade Brasileira de Psicanálise study group in Rio de Janeiro, which was recognized by the International Psychoanalytic Association (IPA). In 1959 he and his colleagues from the study group founded the Sociedade Brasileira de Psicanálise de Rio de Janeiro (SBPRJ). He became a training analyst in 1960. Perestrello presented many purely psychoanalytic studies in addition to those devoted to psychosomatic questions. For more than ten years he was in charge of the Institute's seminars based on Freud's work.

His interest in psychosomatic questions predated his becoming a psychoanalyst. In 1958 he published his work entitled *Medicina psicossomática* (Psychosomatic medicine), which was translated into Spanish and published in Buenos Aires.

In the same year he organized and directed the Center for Psychosomatic Medicine attached to the chair of clinical medicine in the federal university of Rio de Janeiro. In 1965 he was one of the architects and founders of the Associação Brasileira de Medicina Psicossomática (ABMP). The founding assembly held in São Paulo elected him as its first president.

In 1974 he published *Medicina da pessoa* (Medicine of the person), which became the conceptual source behind the teaching of psychosomatic medicine in

Brazil's leading medical faculties. The first edition of the *Revue psychosomatique* was devoted to him.

His university teaching was always based on clinical cases. Perestrello manifested an immense respect for his students and patients. He cut a peerless figure in the lecture hall. A brilliant orator, he never failed to capture the attention of his audience. After 1976, already ill and retired from active life, he was elected honorary president of the ABMPE and, in 1986, honorary president of the Brazilian Psychoanalytic Association (ABP). In 1987 his students, wife, and son selected and published his most important works.

As a humanist, Perestrello always exalted human beings; as a doctor, his patients; and as a psychoanalyst, the analyst-patient relation.

MARÍA DE LOURDES SOARES O'DONNELL

See also: Brazil.

### **Bibliography**

- Perestrello, Danilo. (1954). Headache and primal scene. *International Journal of Psycho-Analysis*, 35, 219–223.
- . (1969). Sigmund Freud medico. *Revista Uruguaya de Psicoanálisis*, 11, 3–4.
- . (1973). Contribuição da psicanálise a medicina. *Revista Latina-Americana de Psicanálise*, 5, 3.
- . (1974). *A medicina da Pessoa*. Rio de Janeiro : Livraria Atheneu.
- . (1987). *Trabalhos escolhidos*. Rio de Janeiro : Livraria Atheneu.

## PERRIER, FRANÇOIS (1922–1990)

The French psychiatrist and psychoanalyst François Perrier was born on July 25, 1922 in Paris and died on August 2, 1990, also in Paris, at the Hôtel-Dieu hospital.

His father, Martial, was a journalist and poet—his works were published by his friend Bernard Grasset—and his mother, a musician, taught him to play the piano when he was a very young child. He studied medicine and then psychiatry in Paris, and in 1951 defended his doctoral thesis directed by Jean Delay, titled “Les données apportées par la spectrographie dans l'étude du syndrome humoral de l'électrochoc”

(The contribution of spectographic data to the study of humoral syndrome in electroshock therapy).

In 1949 Perrier went into analysis with Maurice Bouvet, and in 1953 he participated in the student revolt in the Société psychanalytique de Paris (SPP; Paris Psychoanalytical Society). He followed the founders of the Société française de psychanalyse (SFP; French Society of Psychoanalysis), becoming an associate member at the same time as Vladimir Granoff and Serge Leclaire, in 1954, the year his first psychoanalytic text, “La psychothérapie des schizophrènes” (Psychotherapy for schizophrenics) was published.

Beginning in 1956 he provided psychoanalytic consultations at the Hôpital Sainte-Anne at the same time as presentations of the patients of Daniel Lagache and Jacques Lacan, as well as a seminar on analytic clinical practice with Leclaire and Granoff. In 1953 he undertook a period under Lacan’s supervision, and in 1956 began an analysis with him that lasted until 1963.

From 1960 Perrier, Granoff, and Leclaire (nicknamed “the Troika”) took part in various negotiations with the International Psychoanalytic Association (IPA), attempting to secure the integration of the SFP. After the failure of these attempts, Perrier joined the camp of Lacan.

It was in Perrier’s home that, on June 21, 1964, Lacan founded the École freudienne de Paris (Freudian School of Paris). Perrier was on the École freudienne’s first board of directors; he was also the first to resign from the board, on December 1, 1966, on grounds of disagreement over the training of analysts. On January 26, 1969, during the hearing on “the pass” at the Hôtel Lutetia, he resigned from the École freudienne, along with Piera Aulagnier and Jean-Paul Valabrega. Again at his home, the Quatrième Groupe (Fourth Group) was founded in February 1969; he became its first president. In 1969 he wrote an article on training analysis that appeared in the first two issues of *Topique*. He finally resigned from the editorial committee of this journal in 1974, following its refusal to publish his article, “Thanatol.” Thereafter he devoted himself to the publication of his work, with the collaboration of Jacques Sédât. He resigned from the Quatrième Groupe in 1981.

Perrier’s vast body of work shows an analytic and original approach to the totality of clinical practice, whether it is a question of phobias (1956), erotomania

(1966), schizophrenia and psychosis (from 1956), alcoholism, hysteria, or female sexuality. He also contributed to thinking about the training of analysts and training analysis (1969).

For many years Perrier taught a seminar in psychoanalysis. Some of his seminars have been published.

JACQUES SÉDAT

*See also:* Alcoholism; Claustrophobia; Colloque sur l’inconscient; École freudienne de Paris; Femininity; France; Pass, the; Psychoanalytic splits; Quatrième Groupe (O. P. L. F.); Société française de psychanalyse.

### Bibliography

Perrier, François. (1978). *La chaussée d’Antin (incl. Perrier’s unpublished correspondence with Lacan, biography and bibliography established by J. Sédât)*. Paris: Albin Michel; new ed. 1994.

———. (1984). *Les corps malades du signifiant: séminaires 1971–1972*. Paris: InterÉditions.

———. (1985). *Double lecture: le transsubjectal: séminaires 1973–1974*. Paris: InterÉditions.

Perrier, François; and Granoff, Vladimir. (1960). *Le désir et le féminin*. Paris: Aubier.

---

## PERROTTI, NICOLA (1897–1970)

Nicola Perrotti, an Italian psychoanalyst and physician, was born in Penne (Pescara) in 1897 and died in Rome in 1970. He was one of the pioneers of psychoanalysis in Italy. Perrotti, a humanist with considerable clinical sensitivity, after receiving his doctorate in medicine in Rome in 1922, turned to Freud’s new science. Even before he underwent psychoanalytic training, he defended the cause of psychoanalysis in the pages of *Il Saggiatore*, an avant-garde cultural review.

In 1932 he began analysis with Edoardo Weiss and soon became one of his close collaborators. Again with Weiss, in 1934 he participated in the International Psychoanalytic Congress in Lucerne, where he presented his “Psychoanalytic Considerations on Music.” In 1935 the *Internationale Zeitschrift* published one of his most original essays, “Die Righophobie” (Phobia of cold), confirming Freud’s predictions to Weiss (1970) that “his collaborator Perrotti had the potential to become a prize winner.”

After the Italian Psychoanalytic Society (SPI) was forced to dissolve in 1938 and following Italy's entrance into the War, Perrotti returned to the political movements he had followed in his twenties, when he was a militant in the Socialist Party, struggling alongside men such as Nenni, Saragat, and Pertini. He was elected deputy of the new Italian Parliament and appointed High Commissioner for Hygiene and Health, a position he left in 1950.

During this period of political engagement, Perrotti continued to take an interest in the status of psychoanalysis in Italy. In 1946, with Emilio Servadio and Cesare Musatti, he reestablished the SPI, of which he was president until 1951. Through his friendship with Maryse Choisy, he took advantage of his contacts in France to enter the European circuit of psychoanalysis. The subsequent Congress of Romance Languages Psychoanalysts provided Perrotti with an opportunity to work with distinguished representatives of French psychoanalysis and helped formalize his contacts.

In 1952, after his term as president of the SPI had ended, he founded the Istituto di Psicoanalisi di Roma (Rome Psychoanalytic Institute) and, in 1963, managed the newly reestablished review *Psiche*. His most important articles were published in *Psiche*, the *Rivista di psicoanalisi* and the *Revue française de psychanalyse*. During his lifetime, he published seventy articles, which were collected in a posthumously published anthology entitled *L'Io legato e la Libertà* (The bound ego and freedom), whose main topics were the identity crisis of contemporary man, the metapsychology of the self, depersonalization, and aggression.

ANNA MARIA ACCERBONI

See also: Italy.

### Bibliography

Perrotti, Nicola. (1989). *L'Io legato e la libertà*. Rome: Astrolabio.

Petacchi, Giancarlo. (1970). Vita di pionieri. (p. 168–173). In A.M. Accerboni (Ed.), *La cultura psicoanalitica*. Pordenone, Italy: Studio Tesi.

*Psiche*. (1970).

## PERSECUTION

The term “persecution” derives from the vocabulary of religion and was used to describe the torture and

torments inflicted on the early Christians martyrs. In everyday usage, it characterizes all relationships in which one party, the persecutor, pursues the other, the persecuted, with malevolent intentions, cruelty, and hatefulness.

In the language of psychopathology, the term “delusions of persecution” has been used to refer to the ideas and feelings described in patients with various diagnoses, including paranoia, schizophrenia, melancholia, and hypochondria. Freud's hypothesis is that a delusion of persecution is the result of a defense against unconscious homosexual impulses.

Described since antiquity, feelings and ideas of persecution were noted in connection with various clinical entities until the second half of the nineteenth century, when new systems of psychiatric classification isolated them into a separate and independent category (Legrand du Saule, 1871). In the early twentieth century, German psychiatry characterized persecution in relation to “paranoia” while French authors dismissed what they called *folie raisonnante*; even though it was clear that other pathologies (for example, the paranoid form of dementia praecox) could include this type of delusional thinking.

Today, clinicians tend to recognize the persecution dimension in a number of conditions, including erotomania, delirious hypochondria, or delirious jealousy; these conditions do not actually reach the level of “delusions of persecution” in the strict sense of the term, but all involve essential aspects of the persecutory relationship— projection, passionate and one-sided attachment, and acting out.

In his commentary on Daniel Paul Schreber's autobiography (1911c), Freud described the mechanism of symptom formation, the underlying unconscious fantasy, and the level of fixation of a persecutory relationship. He saw the onset of the disorder in “sexualization of their social instinctual cathexes” (p. 62) and suggested that these cathexes are the result of inhibition of homosexual tendencies (the erotic component of friendship) arising from the stage when object choice is narcissistic. The unconscious fantasy of the persecutory relationship thus represents the fixation to this homosexual stage of the libido.

Finally, to explain the way that symptoms of persecution develop, Freud suggested the specific mechanism of “projection.” The impossibility of accepting “I (a man) love him (a man)” is unconsciously transformed into “I

*hate* him.” But this formulation, representing the return of the repressed, cannot become conscious in such form and Freud writes that, “thus the impelling unconscious feeling makes its appearance as though it were the consequence of an external perception. ‘I do not love him—I hate him, because he persecutes me’” (p. 63).

Delusions of persecution represented Freud’s first attempt to identify certain mental pathologies with reference to psychic mechanisms other than repression and the “return of the repressed.”

VASSILIS KAPSAMBELIS

*See also:* Act, passage to the; Anxiety; Delusion; Double, the; Helplessness; Internal object; Megalomania; “On the Origin of the ‘Influencing Machine’ in Schizophrenia”; Paranoia; Paranoid-schizoid position; Privation; “Psycho-Analytic Notes on an Autobiographical Account of a Case of Paranoia (Dementia Paranoides)”; Psychoses, chronic and delusional.

### **Bibliography**

Freud, Sigmund. (1911c). Psycho-analytic notes on an autobiographical account of a case of paranoia (dementia paranoides). *SE*, 7: 1–82.

Legrand du Saule, Henri. (1989). *Le delire des persecutions*. Paris: G. R. E. C.

## **PERU**

The first reference to psychoanalysis in Peru dates from a thesis presented in 1914. The following year, Honorio Delgado published an article on the new discipline in the country’s most important daily. In 1918 he and Hermilio Valdizán founded the *Revista de psiquiatría y disciplinas conexas* (Review of psychiatry and associated disciplines), the first mouthpiece for psychoanalysis in Latin America. In 1919 he wrote the first Spanish work on the subject. That same year he received a letter from Freud, the first in an epistolary exchange that was to last until 1934.

Although Freud was interested in enlisting Delgado—whom he cited as an example of his influence in Spanish-speaking countries, and whose articles and reports appeared in *Imago*, the *Internationale Zeitschrift für Psychoanalyse*, *Psychoanalytic Review* and the *International Journal of Psycho-Analysis*—the Peruvian physician, on the other hand, manifested some reticence. He attended the Berlin Congress on Freud’s

invitation. He arrived late but nevertheless managed to meet the founder of psychoanalysis. In 1926 Delgado published Freud’s biography and paid homage to him in the National Academy of Medicine. Paradoxically, in 1927, just as he was beginning to manifest a much more critical attitude, he was made a member of the British Psychoanalytic Society (BPS), attended the Innsbruck congress, and visited Freud at Semmering.

Having been a major figure in Peruvian psychiatry for more than thirty years, Delgado changed position from that of an exponent to that of a detractor. He was the architect behind the enthusiastic welcome that psychoanalysis received in the 1920s, when the discipline was introduced into psychiatry lectures and when the most important reviews published translations of Freudian texts—in 1926 one of them devoted an entire issue to Freud and psychoanalysis. José Carlos Mariátegui, the most eminent Peruvian thinker of the 20th century and founder of the Peruvian Communist Party, devoted an article to psychoanalysis as well as a chapter in one of his books. In 1929, one year before his premature death, he wrote a psychoanalytically informed article on literature.

Delgado’s opposition in the 1930s was an obstacle to the expansion of the psychoanalytic movement, which was suspended for another four decades. With the exception of some isolated articles and a few theses, the psychiatric milieu lost all interest in the discipline. It disappeared from the scene for several years, until reintroduced through the influence of Carlos Alberto Seguin. The science journalist, Oscar Miró Quesada (RACSO), nevertheless devoted several articles to Freud and psychoanalysis, as well as a book in 1937.

In 1940 Seguin published a book in Buenos Aires on Freud. He later went into analysis and frequented the New York Psychoanalytic Institute. For many years he was director of the first psychiatry department attached to a general hospital in Latin America and contributed to promoting dynamic psychiatry and psychosomatic medicine on psychoanalytic bases. He was president of the psychoanalytic section of the Peruvian committee at the first World Congress on Psychiatry. His influence was of major importance: ninety percent of psychiatrist members of the Peruvian Psychoanalytic Society studied under him.

Saúl Peña’s return to Peru in 1969 marked the beginning of active work in university and clinical



circles, which continued with the returns of Carlos Crisanto in 1973 and Max Hernández in 1974, the year of the foundation of the Center for the Development of Psychoanalysis. In 1979 the International Psychoanalytic Association (IPA) recognized this institution as a provisional study group and appointed a sponsoring committee which admitted the three analysts as training analysts and selected the first candidates.

Founded in 1980, the Peruvian Psychoanalytic Society was accepted as a study group in 1981. Peña, Crisanto, Hernández and the new sponsors made up the joint training committee of the brand new Peruvian Institute of Psychoanalysis. In 1985 the group acquired the status of a provisional society and that of a member society in 1987.

With Sara Flores as president, the Society had forty-eight associate and full members as of 2004, to which we must add the twenty-two candidates and students from the Institute directed by Jorge Kantor, and the eleven candidates from the seventh group to begin training. The many influences from psychoanalysts trained abroad and the foreign personages associated with the society have contributed to representing very different schools (British-independent and Anna Freud, East and West Coast United States, Argentina, France, and Frankfurt).

The society has organized and/or sponsored eight national congresses and other events, mainly international and inter-disciplinary, which have contributed to forging a role in cultural life for psychoanalysis as well as having an influence on artists, specialists in the social sciences, educators, historians, writers, psychologists, and psychiatrists. The 1998 international conference "On the Threshold of the Millennium" and "At the End of the Battle" (2001), both co-sponsored by the IPA and UNESCO, also aroused the interest of politicians, economists, captains of industry, diplomats, and the general public.

Since 2001 the most prestigious private university of the country has a Master's Program in Psychoanalytic Theoretical Studies, organized by Max Hernández and Moisés Lemlij, whose second class is about to graduate. Also the most widely read weekly in the country has a column presenting a psychoanalytic point of view and a psychoanalyst heads a radio program where people seek advice and consultation.

Max Hernández is one of the leading intellectuals in contemporary Peru and a major personality in the

Peruvian Society. His influence extends beyond the discipline and his contributions have been rewarded with the Sigourney prize. During his presidency of the FEPAL, Saúl Peña, the first president and honorary president of the Peruvian society, organized the first Latin American Congress of Child and Adolescent Psychoanalysis and presented the contributions of Latin American psychoanalysis in the form of various publications.

César Rodríguez Rabanal, a former member of the Peruvian Society and an important leader of opinion, made a renowned contribution on the subject of how to approach marginalized and under-privileged populations. As an active promoter on an international level of culture in general and psychoanalysis in particular, Moisés Lemlij has twice been vice-president and treasurer of the IPA. Álvaro Rey de Castro, current President of FePAL, stands out for his active participation in the war against corruption.

The main psychoanalytically-informed institutions in Peru are: the Center for Psychosocial Development and Counseling (1976), the Lima Center for Psychoanalytic Psychotherapies (1983), the Association for Child Psychotherapy (1986), the Center for Psychoanalysis and Society (1986), the Interdisciplinary Seminar on Andean Studies (1987), the Center for Human Development and Creativity (1995), the Center for the Development of Art Therapy (1997), and the School of Applied Clinical Psychotherapy (1999). The Lacanian movement is still at an embryonic stage.

The leading works are published by the Biblioteca Peruana de Psicoanálisis and the Fondo Editorial SIDEA. Directed by Moisés Lemlij, these publishing centers have together published more than thirty works since the early 1990s. Also worthy of note is the *Libro anual de psicoanálisis* (Annual book of psychoanalysis), published by Gustavo Delgado (The Peruvian Society publishes a journal, *Psicoanálisis*, every two years).

MOISÉS LEMLIJ

See also: Delgado, Honorio; *Revista de psiquiatría y disciplinas conexas*; Valdizán, Hermilio.

### **Bibliography**

Delgado, Honorio. (1989). *Freud y el psicoanálisis*. (J. Mariátegui, Comp.). Lima: University Cayetano Heredia.

Hernández, Max. (1992). *Memoria del bien perdido. Identidad, conflicto y nostalgia en el Inca Garcilaso de la Vega*. Lima: Instituto de estudios peruanos y biblioteca peruana de psicoanálisis.

Hernández, Max, et al. (1996). *Entre el mito y la historia*. 3d. ed. Lima,:Fondo Sidea. (Original work published 1987)

Rey de Castro, Álvaro. (1991). *Freud y Honorio Delgado: una aproximación psicoanalítica a la prehistoria del psicoanálisis peruano y sus escuelas, el múltiple interés del psicoanálisis-77 años después*. (p. 203–237). Talleres de Artes Gráficas Espino.

Rodríguez, Rabanal César. (1989). *Cicatrices de la pobreza*. Caracas, Venezuela : Nueva Sociedad.

## PERVERSION

To posit a “perverse” sexuality is to imply the existence of a “normal” variety with reference to which certain acts and object-choices are deemed deviant. In the *Three Essays on the Theory of Sexuality* (1905d), Sigmund Freud stated that the aim of adult sexuality was to reach orgasm by means of genital penetration, but he tempered this rather normative statement by observing that “the disposition to perversions is itself of no great rarity but must form a part of what passes as the normal constitution” (p. 171).

This was the basis of Freud’s celebrated formula according to which “neurosis is the negative of perversion” (pp. 165, 231). In his turn—or perhaps rather his return—to Freud, Jacques Lacan followed up by underlining the importance of the absence of the father in cases of perversion, and at the same time claimed that perversion was above all attributable to the mother’s putting her child in the place of the phallus (2002 [1955–56], p. 188). The pervert-to-be was thus chained to the desire/demand of the mother. It should be borne in mind, however, that Lacan was chiefly interested in the form of a “third structure” between the psychotic structure and the neurotic, so that for him perversion was a specific structural category rather than a class of sexual behavior to be set against an established norm.

It is difficult, from the psychoanalytical perspective, to frame a satisfactory definition of what, among adult sexual activities and object-choices, might constitute a symptom. Should homosexuality, for example, always be looked upon as a symptom? Or should it be viewed simply as a variation of male or female sexuality? Psychoanalysts are sharply divided on this clinical question.

First of all, the polymorphous features of adult sexuality hardly need underlining. Countless patients, whether heterosexual or homosexual, describe an infinite variety of erotic scenarios, fetish objects, masquerades, sadomasochistic games, and so on, which constitute private areas in their love lives, and which they experience neither as compulsive nor as indispensable to their sexual gratification.

Since every psychological symptom constitutes an attempt at self-cure intended to spare the sufferer painful mental conflict, this may be said equally of symptomatic sexuality (inasmuch as we are able to define it). Such a constructive approach to the meaning and aim of sexual symptoms, and of the reason for their formation, invariably leads to the conclusion that they embody infantile solutions to the confusions and anxieties attending sexual difference and sexual identity. The need to reinvent the sexual act often turns out to be closely tied to the parents’ unconscious, or to silent messages or deceptive communications from the parents concerning sexual identity, adult sexuality, and notions of “feminine” and “masculine.”

If some patients can achieve sexual satisfaction only by recourse to fetishistic, sadomasochistic, or other scenarios, the analyst might well wish that their sex life were less constrained, less subject to rigid conditions; yet if such erotic rituals are indeed for them the *sine qua non* of sexual relations, there is no justification for wanting these patients to abandon their erotic practices, whether or not other people consider them perverse.

As for the primal scene and the troubling fantasies to which it is apt to give rise, these tend—apart from their genital aspects and the phallic-oedipal conflicts they arouse well before the oedipal crisis proper—to bear the stamp of the pregenital: the fantasies in question feature *devoration*, or erotic and sadistic exchanges of an anal or fecal kind. When such fantasies predominate, they often fail to be integrated into genital eroticism and thus lead to so-called perverse sexual solutions.

Even more inhibiting than fantasies originating in the pregenital psychosexual stage are archaic fantasies involving vampirism, implosion, and fears of the loss of identity or of the sense of the boundaries of the body. When such fantasies, characteristic of early infancy, play a predominant part in the mental reality of adult individuals, sexual and love relationships are

liable to be experienced as a threat of castration, annihilation, or death.

In order to achieve a gratifying sexual or love life, individuals inhabited by such terrifying fantasies find themselves obliged by the force of their unconscious to invent means whereby their castration anxiety and fear of annihilation—to which may be added feelings of confusion as to sexual identity, of emptiness, and of inner death—can be transformed into eroticized games. As an absolute prerequisite to sexual relations, adults in this situation commonly require complex theatrics: constraining conditions, disguises of all sorts, pregenital sexual behavior including the exchange of excrement, and so on—all meticulously stage-managed.

Most patients who re-enact the primal scene in this way feel that their erotic acts and object-choices are conflict-free and consonant with their desires, even if other people adjudge them perverse. The specific form assumed by a person's sexual predilections becomes a clinical problem in need of solution only if it causes that person to suffer. The real question is not whether particular acts or preferences should be judged deviant, but when a given deviation should be considered a variation from adult sexuality within the context of a significant object-relationship and therefore be treated as symptomatic.

A good many authors continue to use the term "perversion" in a pejorative way, but only inasmuch as it connotes a proclivity towards evil. Thus Robert Stoller (1975) confines the use of the word, which he defines as "the erotic form of hatred," to any sexual act whereby a person seeks deliberately to hurt someone else. Joyce McDougall (1995) uses the term "neosexual" to qualify the kind of scenarios described above and suggests that "perverse" be applied exclusively to specific relations, notably sexual relations, imposed by one individual on another who does not consent thereto (as for instance a child or a mentally disturbed person): in other words, sexual relationships in which one of the partners is utterly indifferent to the vulnerability or the desire of the other. It is worth noting that these same acts belong more often than not to the class of behavior that is condemned by the law: sexual abuse of minors, rape, exhibitionism, and so forth. The sexual activity of consenting adults, whether or not it is considered deviant with respect to supposed norms, tends not to be treated as illegal.

In short, where neosexual practices do no harm to either partner, nor seem to display a relentless compulsiveness of which the subject him or herself complains, the analyst has no cause to wish another erotic perspective upon the patient. It should be remembered that neosexualities serve not only to repair breaches in the sense of sexual and subjective identity but also, unconsciously, to protect their internal objects from the subject's hate and destructiveness, which derive in part from the unworked-out oral and anal impulses characteristic of incorporative infantile love. In the course of an analysis, the meaning of the love relationships of sexual innovators is revealed. It transpires in fact that their "choices" represent the best solution that the sometime child was able to find in response to messages from the parents. The feeling of choice is nonexistent, whether the individual is heterosexual, homosexual, autosexual, and/or neosexual.

Thanks to the uncovering of neosexual scenarios, what had been nonsensical becomes significant and meaningful, and a feeling of vitality prevails, at least momentarily, over inner death. These same problems might otherwise have produced graver outcomes of a psychotic or psychopathological order. Despite the often constraining conditions imposed by patients' compulsions and anxiety, which so often define the repertoire of sexual deviations, the underlying self-curative intent in face of conflicts of a neurotic or psychotic kind means that Thanatos is bound and that Eros triumphs over death.

JOYCE McDOUGALL

*See also:* Bisexuality; Borderline conditions; "Claims of Psycho-Analysis to Scientific Interest"; Exhibitionism; Fetishism; Idealization; Imposter; Repetition; Sadomasochism; Signifier; Splitting; Splitting of the ego; Transgression; Voyeurism.

### **Bibliography**

- Freud, Sigmund. (1905d). Three essays on the theory of sexuality. *SE*, 7: 123–234.
- Lacan, Jacques. (2002 [1955–56]). On a question prior to any possible treatment of psychosis. In *Écrits: A selection*. (Bruce Fink, Trans.). New York: Norton.
- McDougall, Joyce. (1995). *The many faces of Eros: A psychoanalytic exploration of human sexuality*. New York: W.W. Norton.

Stoller, Robert. (1975). *Perversion: The erotic form of hatred*. New York: Pantheon.

### Further Reading

Bach, Sheldon. (1994). *The language of perversion and the language of love*. Northvale, NJ: Jason Aronson.

Goldberg, Arnold. (1995). *The problem of perversion. The view from self psychology*. New Haven, CT: Yale University Press.

Kernberg, Otto F. (1991). Sadomasochism, sexual excitement, and perversion. *Journal of the American Psychoanalytic Association*, 39, 333–362.

## PERVERSION (METAPSYCHOLOGICAL APPROACH)

The concept of perversion is a recent one, though the word has been in use since the beginning of the third century, when it meant “to invert” or “to make something go wrong.” Among Christians, it means “to corrupt, distort (minds).” Literary scholars use it to mean “to falsify a text.” The term developed and from the second half of the nineteenth century it entered everyday language, particularly in its sexual sense.

The Graeco-Roman world does not have a concept of perversion, whereas the Christian world considers sexuality in general as a sin. Curiously, the reference to alternative sexual practices and sexual practice without a reproductive purpose within psychiatry served to liberate sexuality from religion.

Perverse phenomena were beginning to be investigated in the clinical medicine of Freud’s time; Krafft-Ebing, in Germany, and Havelock Ellis, in England, were Freud’s precursors in this area. Freud, however, was the first to indicate the polymorphous perverse constitution of the child, breaking with the cherubic vision of the child that had prevailed until then and creating huge scandal. Freud’s revolution introduced a metapsychological approach to perversion; that is, an approach that comprises economic, topographical, and dynamic views of perverse practice and which does not separate it from normal sexual life. In *Three Essays on the Theory of Sexuality* (1905d), Freud writes: “Everyday experience has shown that most of these extensions, or at any rate the less severe of them, are constituents which are rarely absent from the sexual life of healthy people, and are judged by them no differently from other intimate events. If circumstances

favour such an occurrence, normal people too can substitute a perversion of this kind for the normal sexual aim for quite a time, or can find place for the one alongside the other. No healthy person, it appears, can fail to make some addition that might be called perverse to the normal sexual aim; and the universality of this finding is in itself enough to show how inappropriate it is to use the word perversion as a term of reproach” (1905d, p. 160).

The case that Freud defines as “severe” is when a “perversion, instead of merely appearing *alongside* the normal sexual aim and object, and only when circumstances are unfavourable to *them* and favourable to *it*—if, instead of this, it ousts them completely and takes their place in *all* circumstances—if, in short, a perversion has the characteristics of *exclusiveness* and *fixation*—then we shall usually be justified in regarding it as a pathological symptom.” He concludes: “This gives us a hint that perhaps the sexual instinct itself may be no simple thing, but put together from components which have come apart again in the perversions” (1905d, pp. 161–162).

Our interest now concerns these different components of sexual life, which may have originated from the erogenous zones but consist of something more than these. Later, in the same work, Freud writes: “It must, however, be admitted that infantile sexual life, in spite of the preponderating dominance of erotogenic zones, exhibits components which from the very first involve other people as sexual objects. Such are the instincts of scopophilia, exhibitionism and cruelty, which appear in a sense independently of erotogenic zones; these instincts do not enter into intimate relations with genital life until later, but are already to be observed in childhood as independent impulses, distinct in the first instance from erotogenic sexual activity” (1905d, pp. 191–192).

Accordingly, exhibitionism, voyeurism, sadism, and masochism are the first “partial drives.” Freud considered that it is these “partial drives” that require the presence of other people as sexual objects from the outset. Thus, a degree of distance is established between the sexual nature of the object and its capacity to satisfy the needs connected with the erogenous zones. Furthermore, because they require the integration of “other people,” exhibitionism and voyeurism and sadism and masochism form the basis of every identification and therefore of the formation of the

ego. This viewpoint is far removed from the simplistic theories based on a genetic approach.

Two problems arise concerning Freud's interest in the perversions. The first relates to his interest in masochism and the second to his interest in fetishism, which are in fact the only two perversions in which he seems to take a close interest. Freud explains his interest in masochism as a perversion in the 1919 article "A Child Is Being Beaten" (1919e). There he outlines the different stages that give rise to the masochistic fantasy: first, "My father is beating the child" and, above all, "My father is beating the child *whom I hate*"; second, "I am being beaten by my father"; third, someone is beating many people, a phase that corresponds to a return to the first fantasy, now reinforced, which becomes: "My father does not love this other child, *he loves only me.*" These fantasies correspond to residues of the oedipal elaboration and are one of the sources of the formation of the superego.

This text seems somewhat inaccessible today without a critical apparatus that takes into consideration both its connection with Anna Freud's text on "The Relation of Beating Fantasies to a Daydream" (1923) and the shared origin of both texts in Anna's analysis by her father and the presentation of this young woman as a member of the Vienna Psychoanalytical Society in that same year. These are complicating factors for their impact in explaining masochism in general.

Freud takes up this theme again in 1924 in "The Economic Problem of Masochism," a text that is of great theoretical and metapsychological interest, specifically for its identification of the death drive as the origin of masochism. Nevertheless, this text seems both to be overshadowed by the 1919 text and to introduce a methodological bias: Freud attributes a form of masochism to women that he explains in this text that he has only ever been able to observe clinically in men. The problem seems to be that Freud never entirely accepts the existence of two sexes and that he systematically reduces "femininity" to "underdeveloped masculinity" if not to "infantility" in its masculine form.

In the article "Fetishism" (1927e), Freud bases the essence of his theories on fetishism on the voyeuristic quest for the maternal phallus, in conjunction with the fears that are concealed by this quest. He remains cautious: "But I do not maintain that it is invariably possible to discover with certainty how the fetish was

determined" (1927e, p. 155). However, his theoretical association leads him to connect the formation of the fetish with the dead father on the one hand and with the splitting of the ego on the other and to the theories that he had already developed at the time concerning the differences and similarities between neurosis and psychosis.

The article poses some problems. Freud conflates "phallus" and "penis," making no distinction between the terms. The "maternal phallus" and "the mother's penis" are not interchangeable terms. The term "phallus" designates a representation of the erect penis that dates back to the Dionysian cults of Ancient Greece. During the Roman Empire, this term was linked more to fascination but it is not reduced to the symbol of the erect penis. Everything that appeals in terms of procreative capacity is called "phallic." The erection is only one of the possible states of the penis and by far the least ordinary, but Freud does not give any reasons why the child would expect to encounter an "erect penis" in his mother. Furthermore, if Freud is referring to the procreative capacity, the association with the penis is superfluous since the mother is just much a parent as the father.

Further, Freud rejects the concept of "scotomization" that was put forward by René Laforgue, and thus rejects his own concept of *Verwerfung* (foreclosure or repudiation), whereas Laforgue's proposition would have established a link between the perversions and the psychoses in accordance with Freud's theories concerning the definite presence of perverse fantasies in the psychoses as well as in the neuroses. If the neuroses are the negative of perversions, do perversions constitute their "positive" as in relation to the psychoses? Furthermore, it seems possible that clinical experience led Freud to abandon the long-established differences between neurosis and psychosis in favor of that new considerations he expounds in this text on fetishism.

Finally, at the dawn of the third millennium, the theory that designates the clitoris as "the normal prototype of inferior organs," the "woman's real small penis" (1927e, p. 157), is considered somewhat problematic. Freud had difficulty recognizing the existence of the two different sexes, and his formulation here considers the woman as deprived of a penis. In this respect, the theory is itself a fetishistic one.

It seems that on the subject of perversions psychoanalysis may not have progressed very far since Freud, but from 1967, structuralism questioned the degree of

variation between neurotic, psychotic, and perverse “structures.” The authors of *Le Désir et la perversion* (Aulagnier-Spairani, P. et al., 1967), several French psychoanalytic clinicians, mainly close to Jacques Lacan, claim to isolate perversion as an entirely separate entity that has no obvious connection with other mental or sexual disorders. Guy Rosolato forwards a “study of the sexual perversions based on fetishism” that essentially adheres to Freud’s framework. However, the dead ancestor becomes the fantasy of the murder of the father, and castration anxiety, attributed only to male individuals, forms the basis for the theory of a general perversion in women. The second article, by Piera Aulagnier, is based on the account of a clinical case but she seems to overlook Freud’s theories on the “universal bisexuality of human beings.” In her view, men would never be able to understand the specific characteristics of female *jouissance*, nor vice versa. Jean Clavreul is interested in the perverse couple but the essentially legalistic viewpoint that he held in 1966 impedes his contribution to an understanding of sexuality, which should consist in taking complete stock of forms of human behavior without any disqualifications. François Perrier takes up the traditional discussions in France and establishes a connection between erotomania as it appears in Clérembault’s first observations and Lacan’s much later contributions. In its implications for clinical practice and its great sensitivity throughout, this appears to be the most important essay of the collection.

The efforts to establish a form of “structuralism” in psychoanalysis, which usually take this back to the old psychiatric nosography, have proved persistent in France. However, the claim that “the apparatus of the soul” can be reduced to “psychic structures,” as in every form of psychopathology, involves a neglect of Freud’s theories concerning the dynamics and economy of formations of the soul that constantly forge links between “difficulties in thinking” and particularly between the psychoses, neuroses, and perversions. Their coexistence was established by Freud from the outset of his works. Neo-sexuality does not exist in this third millennium any more than in any earlier period. On the other hand, a form of neo-morality sometimes seems to emerge, which takes a different view of the eternal forms of erotism.

Furthermore, Freud’s characteristic conflation of femininity with infantility has been detrimental to the understanding of female fetishism and the perversions

in general. Thus it has been claimed either that a polymorphous perverse dimension was inherent in femininity or that there could be no such thing as female perversion because women were entirely devoted to sublimation. These are extreme and romantic theories.

In the United States and, less commonly, in France, psychoanalysts have been more concerned about clinical practice and have indicated the female perversions being exercised in a commonplace way in women’s relationships with children (Welldon). Exhibitionism is a further manifestation of female perversion and male voyeurism is integral to it, relating to any part of the body: men look at what women show them; women show what men want to see. The supposed “female masochism” is usually accompanied by a form of sadism and “male sadism” often abandons men to masochism. The opposed pairs of the partial drives as Freud conceived them are indissociable in clinical practice and are frequently interchangeable.

LUIZ EDUARDO PRADO DE OLIVEIRA

*See also:* Perversion.

### **Bibliography**

- Aulagnier-Spairani, Piera, et al. (1967). *Le désir et la perversion*. Paris: Seuil.
- Freud, Anna. (1923). The relation of beating fantasies to a daydream. *International Journal of Psychoanalysis*, 4 89–102.
- . (1905d). Three essays on the theory of sexuality. *SE*, 7: 123–243.
- . (1919e). “A child is being beaten”: a contribution to the study of the origin of sexual perversions. *SE*, 17: 175–204.
- . (1924b). Neurosis and psychosis. *SE*, 19: 147–153.
- . (1924c). The economic problem of masochism. *SE*, 19: 155–170.
- . (1924e). The loss of reality in neurosis and psychosis. *SE*, 19: 180–187.
- . (1927e). Fetishism. *SE*, 21: 147–157.
- Welldon, Estela V. (1988). *Mother, Madonna, whore: The idealization and denigration of motherhood*. London: Free Association Books.

---

### **PFISTER, OSKAR ROBERT (1873–1956)**

Pfister was a Swiss pastor, teacher and psychoanalyst, he was born on February 23, 1873 in Zürich, where he died on August 6, 1956.

Born in his father's Zürich suburban parish (Wiedikon), young Oskar was strongly influenced by his father's liberal Christianity and his mother's Pietism. In the course of his early education Pfister was impressed by classroom group dynamics and the erotic power of sadism. After university studies in philosophy, theology, history, and psychology at Basel and Zürich (1891–1895), Pfister completed his education with a series of courses in psychiatry, psychology, and philosophy in Berlin (1896).

Pfister was pastor of Zürich's Predigerkirche (1902–1939), secondary school teacher (1906–1936), instructor at the Cantonal Teaching Academy (1908–1918), and lay psychoanalyst. He specialized in the application of psychoanalytic thought to theology, education, and the humanities and social sciences; he is also known for his passionate popularization of Freudian analysis. Pfister's life and work are intimately bound up with the city of his birth and death: Zürich.

Pfister's first documented encounter with Freud's work came via Carl Jung in early 1908. Freud's psychology fulfilled Pfister's decade-long search for a coherent and meaningful synthesis of psychological and theological thought. He devoured Freud's works and immediately set to work applying analytic insights to problems of pastoral counseling and teaching. Pfister authored the first popular exposition of Freud's ideas and pioneered psychoanalytic interpretations of history, religion, pedagogy, political science, art, and biography.

During the early years of psychoanalysis (1908–1914) Pfister worked closely with the psychoanalytic leadership (Eugen Bleuler, Carl Jung) and its most important early adherents. In January 1909 Pfister, possibly prompted by Jung, sent one of his first psychoanalytic papers to Freud and began their remarkable thirty-year correspondence. The Freud-Jung-Pfister triad became a leitmotif within Pfister's correspondence with Vienna, laden with political and theoretical implications. Jung collaborated with Pfister on at least two of the latter's publications, a 1909 paper detailing Pfister's first full-length analytic case study, and Pfister's comprehensive 1913 textbook *Die psychanalytische Methode*, prefaced by Freud himself. Jung contributed a section on child psychology to the first edition of Pfister's tome. It seems likely that the two collaborated on several other projects, such as Pfister's

1910 psychopathology of Count Zinzendorf. Pfister is mentioned no less than half a dozen times in Jung's 1912 *Wandlungen und Symbole der Libido*.

During the Freud-Jung schism Pfister's loyalties were sorely tested. Though Freud expressed to his closest colleagues Ernest Jones and Sándor Ferenczi his fears that Pfister would side with Jung against him, once the Zürichers officially withdrew from the International Psychoanalytical Association on July 10, 1913, Pfister took only five days before writing to Freud that he was prepared to join the Vienna Society. Pfister then became Switzerland's leading proponent of Freudian psychology, establishing in March 1919 the Schweizerische Gesellschaft für Psychoanalyse, jointly with Drs. Emil and Mira Oberholzer.

From 1908 until his death in 1956 Oskar Pfister authored hundreds of articles and books on psychoanalytic therapeutic technique, the advantages of analytic pedagogy, and his psychoanalytic theology. His most important works are the first psychoanalytic textbook for lay audiences, *Die psychanalytische Methode* (1913), his potent reply to Freud's 1927 attack on religious belief "Die Illusion einer Zukunft" (The illusion of a future; 1928), and the collection of essays in *Zum Kampf um die Psychoanalyse* (Some applications of psychoanalysis; 1920). Pfister's psychoanalytic pastoral care is detailed in *Analytische Seelsorge* (Analytic soul-searching; 1927). His magnum opus, *Das Christentum und die Angst* (Christianity and fear; 1944), systematically analyzed the concept and historical use of fear in order to expose what he perceived to be Christianity's fatal flaw and, if analytically mastered, perhaps its saving grace. The 1963 publication of the Freud-Pfister correspondence remains an important source of information on these men, though very few of Pfister's letters appear in the volume.

In addition to his written work, Pfister frequently toured Europe (particularly Scandinavia) giving dozens of lectures to large audiences of teachers, pastors, and laymen. Among his closest colleagues, were found Hermann Rorschach, Ernst Schneider, Hans Zulliger, and (before 1913) Carl Jung, Alphonse Maeder, and Franz Riklin. Under his tutelage Jean Piaget, among many students after 1909, first learned psychoanalytic technique. One of the first lay practitioners, among Pfister's many analysands were Henri Ellenberger, Emil Oberholzer, and Harold and Kristin Schjelderup.

Oskar Pfister's impact has been recognized by the American Psychiatric Association, which awards the annual Oskar Pfister Prize, for the finest work in religious psychology. The 1973 centennial celebration of his birth in Zürich produced a series of excellent monographs on his contributions to analysis, pastoral psychology, and education. Pfister did not establish a school, though Zulliger and Schneider in analytic pedagogy, and a small group of pastors in Zürich continued his work long after his death. Pfister's importance derives mainly from his thirty-year friendship with and impact upon Sigmund Freud. From his defiant choice to remain a Freudian when the body of the Zürich group left the IPA in 1913, to his role as anonymous interlocutor in Freud's *Die Zukunft einer Illusion*, Pfister served Freud and the psychoanalytic movement with total devotion and great skill.

DAVID D. LEE

See also: Denmark; *Future of an Illusion, The*; Religion and psychoanalysis; Schweizerische Ärztgesellschaft für Psychoanalyse; Splits in psychoanalysis; Switzerland (French-speaking); Switzerland (German-speaking).

### Bibliography

- Freud, Sigmund. (1927c). The future of an illusion. *SE*, 21: 1–56.
- . 1965a [1907–1926]. Psycho-analysis and faith; the letters of Sigmund Freud and Oskar Pfister. (Heinrich Meng and Ernst L. Freud, Eds.; Eric Mosbacher, Trans). London: Hogarth Press, 1963.
- Pfister, Oskar. (1917). *The psychoanalytic method*. (Charles Rockwell, Trans.). New York: Moffat. (Original work published 1913)
- . (1920). J. Piaget, La psychanalyse et la pédagogie [Piaget, 1920]. *Imago*, 6, 3, 294–295; trad. J. Moll, *Bloc-notes de la psychanalyse*, 1981, 1, p. 89–92.
- . (1923). *Some applications of psycho-analysis*. New York: Dodd, Mead and Company; London: G. Allen and Unwin.
- . (1927). *Analytische seelsorge. Einführung in die praktische psychanalyse für Pfarrer und Laien*. Göttingen: Vandenhoeck and Ruprecht.
- . (1993). The illusion of a future. *International Journal of Psycho-Analysis*, 74, 557–579. (Original work published 1928)
- . (1948). *Christianity and fear*. London: G. Allen and Unwin.

## PHALLIC MOTHER

The so-called *phallic mother* is a mother who is fantastically endowed with a phallus. Among the male child's earliest sexual theories, he believes that all people have the male genital. By substituting the phallus for the organ that the child thinks the female is lacking, he tries to protect himself from the castration anxiety that arises from the primal fantasies of the mother. The fear of the phallic mother imago tacitly affirms the threat of castration, while at the same time defensively negating it along with all its oral and anal pregenital foundations.

A theory of the phallic mother existed in Sigmund Freud's work from his earliest formulations on the sexual theories of children (1905d, 1908c), and it played a constant role throughout later developments regarding the questions of feminine castration and the maternal penis (1909b, 1910c, 1923b). From 1905 to 1927, these questions were structured by the continuing Freudian exploration of fetishism. The fetishist fears castration excessively, and finds protection from it in a chosen object that serves as an equivalent for the maternal phallus. Further, Freud emphasized the role of the maternal phallic imago in masculine homosexuality (1910c) and its variations in feminine sexuality (1931b, 1933a [1932], 1937c).

Echoing the pioneering works of Freud, Sándor Ferenczi (1913, 1923) described the sexual organs of the mother both as a cavity and as penile. In another attempt to relativize the exclusive predominance that the Viennese gave the phallus, Ernest Jones (1927, 1932) made a case for a partial and secondary castration, an early identification with the mother that allowed for later orogenital bonds. Karl Abraham (1922)—anticipating Melanie Klein in this regard—proposed a “bad mother” as the bearer of the infant's sadistic projections.

Still following the direction indicated by Freud (1910), Melanie Klein marked a shift by locating the site of castration in the oral relation to the breast/penis, which served as a prototype for all others. She believed that within the framework of the pregenital stages of the oedipal conflict, the baby projected onto the maternal breast the destructive drives of its own penis (1926, 1927, 1928). According to Klein, the formidable weapons of the phallic mother are an absent breast that threatens the child's survival, an orally intrusive breast, a devouring mouth/vagina, and an anally penetrating phallus.



According to Klein's theory of early stages of the oedipal conflict, several key concepts are inseparable from that of the phallic mother: the symbolic analogy between breast and penis, projective identification, and the infantile sexual theory of the combined parent-figure (1932). The last term refers to the fantasy that the castrating mother is endowed with the paternal penis, which was incorporated during intercourse; thus it represents the mother and father in a menacing combination.

Today, understanding the investment in the imago of the phallic mother is clinically useful for understanding the pregenital basis of castration anxiety as related to early scenarios of triangulation. Nevertheless, care must be taken because "the relation to the phallic mother is not prior to castration, but rather signified through it" (Green, 1968). In other words, the archaic imago of the phallic mother is expressed in a secondary cultural image only retroactively. Thus there is a great risk of confusion between stages of development and regressive forms if the fantasy of the phallic mother is not understood as an attempt to translate into adult language (secondary process) the phenomenology of the enigmatic early years (primary process).

For Freud, it is the male genital organ alone that plays the central role for both sexes, and any account of this role privileges the masculine. The Freudian view of feminine sexuality, organized around penis envy, has given rise to countless polemics right up to the present day. These ongoing epistemological debates are what gives the question of the phallic mother its historical and cultural substance.

SYLVAIN MISSONNIER

*See also:* Ego ideal/ideal ego; Femininity; imago; *Leonardo da Vinci and a Memory of his Childhood*; Memory; Phallic woman; Primary identification.

### **Bibliography**

Freud, Sigmund. (1905d). Three essays on the theory of sexuality. *SE*, 7: 123–243.

———. (1908c). On the sexual theories of children. *SE*, 9: 205–226.

Green, André. (1968). Sur la mère phallique. *Revue française de psychanalyse*, 32, 1, 1–38.

Klein, Melanie. (1928). Early stages of the Oedipus conflict. *International Journal of Psycho-Analysis*, 9, 167–180. Reprinted in *The writings of Melanie Klein*, vol. 1. New York: Free Press, 1975.

Marbeau-Cleirens, Béatrice. (1987). *Le sexe de la mère et les divergences des théories psychanalytiques*. Paris: Presses Universitaires de France.

---

## **PHALLIC STAGE**

The phallic stage is an infantile organization of libido which follows the oral and anal stages and is characterized by a unification of the component instincts under the primacy of the genital organs. During this period the child, whether boy or girl, conceives, according to Freud, of but one genital organ, the male one, and the antithesis between the sexes is experienced by him or her as one between phallic and castrated. The phallic stage coincides with the culmination and decline of the Oedipus complex. It disintegrates under the pressure of the castration complex.

The phallic phase, according to Freud, precedes and ushers in problems attending the oedipal complex and the castration complex. It is connected with a relative unification of the component instincts under the primacy of the genital organs, and arises after the oral and anal pregenital phases, around the third year of life, along with the first manifestations of infantile sexual curiosity. This is the time when the child becomes aware of the anatomical difference between the sexes, that is to say, of the presence or absence of a penis (1923e).

At the same time, this phase is to be distinguished from the full (post-pubertal) genital organization in one essential respect: the child recognizes and sets store by a single genital organ—the male one. The little boy deals with the threat of castration by disavowing his perception of the female genitals and persisting in his belief that the mother possesses a penis; the little girl reveals her "penis envy" by imagining that she will later grow a penis of her own.

The phallic phase is thus still a pregenital stage. The penis is conceived of as a phallic organ embodying power and completeness rather than a narrowly genital organ: the phallic phase implies the primacy of the phallus, not of the genital.

The male organ is seen as a "small detachable part of the body" that may be lost after the fashion of the

contents of the bowel, and thus the difference between the sexes is interpreted in terms of the theory of castration. According to this pregenital logic, the activity/passivity polarity typical of the anal stage is transposed into the antithesis between phallic and castrated. Only with puberty will the masculine/feminine dichotomy be constructed.

For Freud, the phallic phase, which is also the phase of the Oedipus complex, is destined to disappear with the decline of that complex, which is brought about by the threat of castration. The phallic phase is then “submerged” and gives way to the period of latency (1924d, p. 174).

A phallic organization exists in girls. When the little girl notices the difference between the sexes, specifically, the woman’s lack of a penis, she develops a desire for a penis. This “penis envy” creates resentment toward the mother who has given her no penis and leads her to take her father as a love-object, inasmuch as he can offer her the symbolic equivalent of a penis: a baby.

The relative importance of the phallic phase, and especially of penis envy, a concept considered too phallocentric by some, has given rise to significant debates within the analytic movement.

Melanie Klein and a good number of other authors have postulated the existence of an early phase of female sexual development and, notably, related the vaginal sensations felt by the little girl as early as the second year of life to the development of orality and anality. This has led them to treat the phallic phase as nothing more than a secondary formation with a defensive function only. Thus penis envy, which Freud had placed at the center of his theory of female sexuality, was in Klein’s view (1975 [1957], pp. 199–200) merely a relatively late derivative of the primal wish for the breast and the counterpart of the male’s envious identification with the mother who bears children.

JEAN-FRANÇOIS RABAIN

See also: Genital stage; Oedipus complex; Oral stage; Phallus; Stage or phase.

### Bibliography

Brusset, Bernard. (1992). *Le développement libidinal*. Paris: Presses Universitaires de France.

Freud, Sigmund. (1923e). The infantile genital organization. *SE*, 19: 141–145.

———. (1924d). The dissolution of the Oedipus complex. *SE*, 19: 171–179.

Golse, Bernard. (1992). Cauchemars, rêves et processus de pensée. *Psychiatrie de l’enfant*, 37, 2, p. 395–413.

———. (1992). *Le développement affectif et intellectuel de l’enfant*. Paris: Masson.

Klein, Melanie. (1975 [1957]). *Envy and gratitude*. In *Envy and gratitude and other works, 1946–1963 (The works of Melanie Klein, vol. 3)*. London: Hogarth/Institute of Psycho-Analysis; New York: Delacorte/Seymour Lawrence.

### Further Reading

Greenacre, Phyllis. (1964). Nature of inspiration: A special consideration regarding the phallic phase. *Journal of the American Psychoanalytic Association*, 12, 6–31.

Loewenstein, Rudolph M. (1950). Conflict, autonomous ego development during the phallic phase. *Psychoanalytic Study of the Child*, 5, 47–52.

---

## PHALLIC WOMAN

The term *phallic woman* refers to the fantasmatic image of a woman (or mother) endowed with a phallus or a phallic attribute. It also refers to the fantasy of the woman (or the mother) retaining the phallus internally after coitus.

The expression “phallic mother” appeared in Freud’s work in 1933 in the *New Introductory Lectures on Psycho-Analysis*, in reference to Karl Abraham’s interpretation of the image of a spider. “According to Karl Abraham (1922),” Freud wrote, “a spider in dreams is a symbol of the mother, but the *phallic mother*” (1933a, p. 24). In fact, Abraham had not used the exact expression in 1922, but it could be inferred from what he wrote. Even though the term appeared quite late in Freud’s career, the idea itself was present a number of years earlier in Freud’s work.

In the essay on “Fetishism” (1927e), Freud returned to the idea that he had first advanced in 1910 in *Leonardo da Vinci and a Memory of His Childhood*. The small child believes that the woman (the mother) has a phallus and refuses to give up this belief. The “infantile hypothesis of the maternal phallus,” Freud argued, led to the dominant role that the young Leonardo gave to the vulture’s tail in his childhood fantasy (1910c,

p. 98). It also underlies the formation of a fetish, which is, according to Freud, a substitute for the maternal phallus, the absence of which is denied. The image of the phallic woman or mother is often found in dreams and fantasies, and also in mythology. This imaginary “form of the mother’s body” has its basis in the infantile theory of the maternal phallus and is maintained even after the recognition of the difference between the sexes.

The image of the phallic woman as Freud described it has only given rise to a few tentative elaborations, for example, those of Ruth Mack Brunswick (1940). But it should also be noted that since Felix Boehm brought attention to another version of the fantasy that came to light in his analyses of homosexuals (1926), the term “phallic woman” also refers to the fantasmatic image of a woman with an internal phallus, retained inside her body after coitus. In this version of the fantasy, the woman still “possesses” the phallus.

The notion of the phallic woman generally does not refer to the identification that a girl or woman has with either the maternal or male phallus, nor to the fantasy of possessing a phallus, on which the masculinity complex is founded. And even though women who present so-called masculine traits are often called “phallic,” this is not necessarily what is meant by the term “phallic woman (or mother).”

CATHERINE DESPRATS-PÉQUIGNOT

*See also:* Castration complex; Disavowal; Female sexuality; Femininity; Fetishism; Masculinity/femininity; *New Introductory Lectures on Psychoanalysis*; Penis envy; Phallic mother; Phallic stage; Phallus; “Some Psychological Consequences of the Anatomical Distinction Between the Sexes.”

### **Bibliography**

- Boehm, Felix. (1926). Homosexualität und Oedipuskomplex. *Internat. Zeitschrift für Psychoanalyse*, 12.
- Freud, Sigmund. (1927e). Fetishism. *SE*, 21: 147–157.
- . (1910c). Leonardo da Vinci and a memory of his childhood. *SE*, 11: 57–137.
- . (1933a [1932]). New introductory lectures on psycho-analysis. *SE*, 22: 1–182.
- Mack Brunswick, Ruth. (1940). The preoedipal phase of the libido development. *Psychoanalytic Quarterly*, 9, 293–319.

## **PHALLUS**

The term “phallus” designates the representation of an erect penis, which plays a key role both intra- and inter-subjectively. Freud barely distinguished between the fantasized phallus and the anatomical penis. He called the period between three and five years of age the “phallic stage.” At this stage, infants of both sexes are dominated by the question of who possesses a penis and the related issue of its masturbatory jouissance (gratification), which is clitoral in the case of girls. Up to this point, the mother is imagined as having a penis, and the discovery that she lacks a penis, after an initial denial, precipitates the castration complex.

Jacques Lacan chose to use the term “phallus” for the imaginary and symbolic representation of the penis in order to better distinguish the role of the penis in the fantasy life of both sexes from its anatomical role. Freud’s famous “symbolic equation” of breast, feces, penis, and baby (1916–1917a [1915–1917], 1918b, 1924d) already implied this distinction between the real penis and its phallic representations.

According to Lacan, the phallus at the outset represents what else the mother desires is in addition to the baby. Thus, a pre-oedipal triangle of mother, phallus, and infant arises. At first the infant tries to *be* the phallus for the mother until the moment of a crucial transformation when the child, after identifying the phallus as a static image of completeness and sufficiency, sees it as representing the mother’s desire, and thus her lack. From then on, the phallus takes the form of something missing ( $-\varphi$ ) within any imaginary, and hence libidinal, frame of reference. Thus the phallus comes to signify desire, Lacan says.

The intermittence of its erection, its ability to fade (compare Ernest Jones’s concept of aphanisis), and even the fact that half of all humans do not have it have made the erect penis eminently suited to symbolize the crucial issues of being (subject) and having (object) in both sexes. The penis constitutes the key element in the asymmetrical division that, according to Roman Jakobson, characterizes any symbolic system.

When the phallus takes on the role of signifier, this implies that the subject grasps it in the Other, the locus of the set of signifiers that determines the subject. There it signifies the Other’s desire, which is to say that the Other is marked by her own incompleteness. From then on, the phallus signifies the Other’s

submission to the laws of symbolic exchange, and such incompleteness frees up in the subject her own jouissance.

In his seminar on female sexuality (1998), Lacan further specified what he meant by the term “phallic jouissance.” He used the phallic signifier ( $\Phi$ ) in writing his “formulas of sexuation,” which posit that every human being has to be on one side or the other of the sexual divide. A woman always has something of the phallus (she is not entirely castrated), and the man is only supposed to “have” the phallus when he fantasizes his castration. In Lacan’s symbolic notation, the phallus takes on the formal role of a supplement, which adds to the castration complex the fact that “there is no sexual relation,” as Lacan said, referring to the impossibility of writing an equation of the relationship between the sexes.

BERNARD PENOT

*See also:* Castration complex; Castration of the subject; Dark continent; Desire of the subject; Eros; Female sexuality; Feminism and psychoanalysis; Imaginary identification/symbolic identification; Jouissance (enjoyment); L and R schemas; Look/gaze; Monism; Mother goddess; Name of the Father; Optical schema; Perversion; Psychoses, chronic and delusional; Real, Imaginary, and Symbolic father; Sexual differences; Sexuation, formulas of; Symbolic, the (Lacan); Symptom/sinthome; Topology; Want of being/lack of being.

### Bibliography

- Freud, Sigmund. (1916–1917a [1915–1917]). Introductory lectures on psycho-analysis. *SE*, 15–16.
- . (1918b [1914]). From the history of an infantile neurosis. *SE*, 17: 1–122.
- . (1924d). The dissolution of the Oedipus complex. *SE*, 19: 171–179.
- Lacan, Jacques. (1998). *On feminine sexuality: The limits of love and knowledge* (Bruce Fink, Trans.). New York: W. W. Norton. (Original work published 1972–1973.)
- . (2002). The signification of the phallus. In his *Écrits: A selection* (Bruce Fink, Trans.). New York: W. W. Norton. (Original work published 1958.)

## PHANTOM

In *The Shell and the Kernel*, published in 1978, Maria Torok and Nicolas Abraham attempted to provide a

revised metapsychological approach to their concept of the phantom. The work, which is presented as a collection of older or unpublished articles, is in fact the second volume of *Anasémies*, the first volume of which appeared in 1976 under the title *The Wolf Man’s Magic Word: A Cryptonomy*.

*Anasémies* is a relatively difficult theoretical-clinical work, “a psychoanalytic and transphenomenological space” with an important introduction by Jacques Derrida, “FORs: Les mots anglés de Nicolas Abraham et Maria Torok.” The work is one that signaled a fecund period of reflection about the processes of transgenerational transmission as they were initially addressed by psychoanalysts and later reconsidered by child psychoanalysts, especially from the point of view of so-called developmental psychoanalysis.

In the second volume of *Anasémies*, chapter four is devoted to the concept of the “crypt” and chapter six to the “work of the phantom in the unconscious and the law of ignorance.” The following lines appear at the head of the chapter: “The phantom is the work in the unconscious of the inadmissible secret of an Other (incest, crime, illegitimacy). Its law is the obligation of ignorance. Its manifestation, as anxiety, is the return of the phantom in bizarre words and acts and symptoms (phobic, obsessive, and so on). The phantom’s universe can be objectivized in fantastic stories. There then occurs a particular affect that Freud described as the ‘uncanny.’”

By reworking and somewhat demetaphorizing the concepts of incorporation, identification, crypt, and phantom, Abraham and Torok arrive at the following formulations: “The phantom is also a metapsychological fact. That is, it is not the dead that haunt us but the gaps left in us by the secrets of others. Although the phantom is not associated with the loss of an object, it could (therefore) be the result of a failed process of mourning . . . The phantom of popular belief merely objectivizes a metaphor that operates in the unconscious: the burial in the object of an inadmissible fact . . . The phantom is a formation of the unconscious, which is peculiar in the sense that it has never been conscious—and with good reason—and which results from the passage—whose mode remains to be determined—of the parent’s unconscious to the child’s unconscious . . . The phantom who returns to haunt is the witness of the existence of death buried in the other. . . . By extending our ideas about the phantom, we can see that, in all likelihood, the ‘phantom effect’

is attenuated during its transmission from one generation to another, ultimately extinguishing itself.”

These comments illustrate the drama of the “cryptophoric” subject and the dialectic that arises between incorporation and identification, to the extent that the fantasy of incorporation can play a role as a factor of identificatory refusal through the maintenance of the metapsychological status quo. Abraham and Torok’s *The Shell and the Kernel* concludes with a study of Hamlet’s ghost.

These essays are part of a line of research that has developed in France through the work of authors such as Alain de Mijolla, Haydée Faimberg, Jean-José Baranès, and Jean Cournot, who have assumed critical positions with respect to the theory of the phantom and suggested other approaches to so-called transgenerational phenomena. The work of Abraham and Torok was continued by Serge Tisseron, Didier Dumas, and Claude Nachin.

BERNARD GOLSE

*See also:* Abraham, Nicolas; Cultural transmission; Inter-generational; Secret; Torok, Maria.

### **Bibliography**

- Abraham, Nicolas. (1968). *L’Écorce et le noyau. Critique*, 249.
- Abraham, Nicolas; and Torok, Maria. (1972). *Deuil ou mélancolie: introjecter-incorporer. Nouvelle Revue de psychanalyse*, 6, 111–122.
- . (1986). *The Wolf Man’s magic word: A cryptonymy*. (Nicholas Rand, Trans.) Minneapolis: University of Minnesota Press. (Original work published 1976)
- . (1994). *The shell and the kernel: Renewals of psychoanalysis*. Chicago: University of Chicago Press. (Original work published 1978)
- Dumas, Didier. (1985). *L’Ange et le fantôme: introduction à la clinique de l’impensé généalogique*. Paris: Minuit.
- Mijolla, Alain de. (1981). *Les visiteurs du moi, fantasmes d’identification, confluent psychanalytiques*, 2d. ed. Paris: Les Belles Lettres.
- . (1987). Unconscious identification fantasies and family prehistory. *International Journal of Psychoanalysis*, 68, 397–403.

## **PHENOMENOLOGY AND PSYCHOANALYSIS**

The polysemous term “phenomenology” has been employed in philosophy since the late eighteenth cen-

tury and in psychiatry since the beginning of the twentieth. It is worth looking at its use in these two spheres before examining its relationship to psychoanalytic thought.

In philosophy, the word was introduced by the German Johann Heinrich Lambert as a designation for an empirical description of human experience devoid of all metaphysical presuppositions. This meaning is still current. Borrowing somewhat from the study of perception and from history, Hegel used the word in his *Phenomenology of Mind* (1931) to evoke the stages (consciousness, self-consciousness, reason) whereby human experience, after passing through the universal, appeared first as the experience of concrete singularity and then as the quest for the self-conscious subject. This quest, destined to fail, led humanity through the forms of stoicism, skepticism, and finally phrenology, for which the mind’s being in the world is literally a bone (the phrenologist Franz Joseph Gall claimed that bumps on the cranium corresponded to psychological functions). The dialectic of history, far from being imposed from without, manifested itself in and through this evolution of experience.

These two senses of “phenomenology” coexisted until 1913, when Edmund Husserl, in the first volume of his *Ideas: General Introduction to Pure Phenomenology* (1931), used the term to designate whatever clearly manifests itself after the problem of the existence of the world has been bracketed, in order to describe how the transcendent elements of the world, including other selves and cultural beings, appear in perception, in imagination, in memory, and as essences. Consciousness in this perspective is always consciousness of something, that is, intentionality; phenomenological description excludes introspection.

Husserl’s disciples were largely heterodox. In Germany, his descriptive method helped Martin Heidegger situate man’s existence as being for death, that is, as a derelict and inauthentic being in the world. Max Scheler, for his part, pressed Husserl’s phenomenology into service for his account of “the man of resentment.” In France, Maurice Merleau-Ponty used the term when discussing the incarnation of consciousness in the bodies of humans acting in history. Jean-Paul Sartre, in *The Psychology of Imagination* (1948), argued that consciousness does not present the subject to himself, and that one’s ego is an inhabitant of the world, on a par with the ego of the other.

In psychiatry, there is a similar dichotomy with respect to the use of “phenomenology.” For Karl Jaspers, the word meant the subjective aspect of clinical psychiatric practice, and he proposed a distinction between knowing (*erklären*) and understanding (*verstehen*), according to which knowing implied an objective and natural knowledge, whereas understanding referred to an intuitive feeling. Jaspers regarded the failure of such spontaneous understanding as the distinguishing mark of psychosis, thus incorporating a notion of process in his view of the disorder. Jaspers’s usage was quickly and widely adopted in Anglo-American psychiatry, where “phenomenology” tends to mean simply the lived experience of patients.

Another psychiatric acceptance, just as important, derives explicitly from Husserl and Heidegger. In German-language psychiatry, Viktor von Gebsattel, Erwin Straus, especially Ludwig Binswanger, and later Roland Kuhn and Wolfgang Blankenburg, despite their considerable divergences, were all concerned to show how each basic type of psychopathology corresponded to a particular mode of being in the world (Heidegger), or a particular mode of the transcendental ego (Husserl). *Daseinsanalyse* (being-in-the-world analysis) as a therapeutic technique belonged to this tendency.

Within French psychiatry too there were distinct positions with respect to phenomenology. Eugène Minkowski meticulously showed how various basic pathological situations expressed specific alterations in the subject’s relationships to time and space. Minkowski also recognized the part played by subjective impressions of the clinician in arriving at a diagnosis. Henri Ey built on phenomenology and existentialism in seeking to transcend clinical empiricism and arrive at an organic-dynamic synthesis and a conception of psychiatry as a pathology of freedom.

It is arguable that phenomenology should be expected not to furnish psychiatry with yet one more theory, but rather to describe the conditions that make psychiatry possible and to clarify the place and the roles of psychiatric knowledge without, however, reducing such knowledge to phenomenology.”

The relations between phenomenological attitudes and psychoanalysis, which are neither simple nor schematic, may be viewed from various angles. To begin with, for phenomenology, the existence of the unconscious is far from a central concern, as some in psychoanalysis have asserted. After all, as we have seen, con-

sciousness for phenomenology is defined in terms of intentionality, and introspection is barred as a source of knowledge. Also, if, as Sartre contends, the subject truly exists in the world in the phenomenological sense, and if the ego is not immanent, the phenomenological view (though it cannot speak of “the unconscious”) can acknowledge that the subject escapes his own grasp—a postulate readily embraced as early as the work of Hegel. The charge that the unconscious is reified in this context need not be taken seriously.

Phenomenological knowledge, being essentially descriptive, is hard put to achieve any clear standing within an economic perspective, the perspective of metapsychology. This is a very significant divergence between phenomenology and psychoanalysis.

Though they hail from cultural realms far removed from one another, psychoanalysis and phenomenology may be said to have at least one thing in common: neither is a humanist theory. Neither admits any assumptions prior to what is shown by clinical experience or phenomenological reduction; neither posits a priori that humanity is the measure, good or bad, of all things; neither in advance gives humanity sovereignty over itself; and both can acknowledge the role of conflicts and of seeking to avoid conflicts.

GEORGES LANTÉRI-LAURA

*See also:* Binswanger, Ludwig; Ego psychology and psychosis; Ey, Henri; Identity; Merleau-Ponty, Maurice; Process; Psychoanalytic epistemology; Sartre and psychoanalysis.

### **Bibliography**

- Binswanger, Ludwig. (1971). *Introduction à l'analyse existentielle* (Jacqueline Verdeaux and Roland Kuhn, Trans.). Paris: Minuit.
- Hegel, Georg Wilhelm Friedrich. (1931). *The phenomenology of mind* (J. B. Baillie, Trans.). London: G. Allen and Unwin. (Original work published 1807.)
- Husserl, Edmund. (1931). *Ideas: General introduction to pure phenomenology* (W. R. Boyce Gibson, Trans.). London: G. Allen and Unwin.
- Koning, André J. J. de, and Jenner, Frederick Alexander (Eds.). (1982). *Phenomenology and psychiatry*. London: Academic Press.
- Lantéri-Laura, Georges. (1963). *La psychiatrie phénoménologique: fondements philosophiques*. Paris: Presses Universitaires de France.

Lantéri-Laura, Georges. (1991). *Psychiatrie et connaissance*. Paris: Sciences en situation.

May, Rollo; Angel, Ernest; and Ellenberger, Henri F. (1958). *Existence: A new dimension in psychiatry and psychology*. New York: Basic Books.

Sartre, Jean-Paul. (1948). *The psychology of imagination*. Secaucus, NJ: Citadel Press. (Original work published 1940.)

### Further Reading

Ricoeur, Paul. (1986). The self in psychoanalysis and in phenomenological philosophy. *Psychoanalytical Inquiry*, 6, 437–458.

## PHILIPPINES

The U.S. dominance of the university educational system in the Philippines in the early decades of the twentieth century meant that Filipino doctors looked to that country for its medical models. Several physicians studied in the United States and imbibed psychoanalytic theory from the American tradition.

One of the first was Virgilio Santiago, who completed his medical training at the University of Santo Tomas in the Philippines in 1949. This medical training led him to psychoanalytic training under Robert Waelder, a student of Freud's. He then went on to study at the Menninger Clinic in Topeka, Kansas. This was an unusual route to follow, since most psychiatrists were trained in the dominant organic school of psychiatry. In the 1950s psychoanalysis was strictly forbidden by the conservative Catholic clergy. Santiago was also discouraged by his colleagues from pursuing the field. Nonetheless, in a private practice he found a clientele among the expatriate population, and a small minority of Filipinos suffering from psychosis also consulted him. Santiago's general criticisms of the poor quality of Filipino health care suggest that the average Filipino was unsuited to psychoanalysis (Santiago, 1966).

Two other early pioneers were Baltazar Reyes and Rudolfo Varias. Reyes graduated from the University of the Philippines and then did postgraduate training at the Langley Porter Institute in California before returning to the Philippines to teach and research. Varias trained in classic psychoanalysis in New York. He returned to teach at the institute of public hygiene (now the College of Public Health). In the 1970s he

returned to New York. His departure meant no further development of psychoanalytic psychotherapy at that time.

Not until the end of the 1960s, with the appearance of Lourdes Lapuz's *A Study of Psychopathology* (1969), was orthodox psychoanalytic theory again taken seriously. This groundbreaking book influenced a whole generation of psychiatrists, psychologists, and counselors, who remodeled the original psychoanalytic theory in which they had been instructed to suit the Filipino cultural mold. As in other Asian cultures, people's social and cultural expectations led them to view the doctor as an authority figure, and this required a more interactive role of the analyst. This book was followed by *Children of Oedipus* (Lapuz, 1973), which deals more fully with these issues. In her succeeding works she dealt with marital counseling and couple and family therapy (Lapuz, 1979).

In spite of these developments, however, the modern mental-health system remains poorly understood in the Philippines because of the low level of medical awareness of the population and the prevalence of alternatives to modern medicine, be they indigenous forms of herbal healing or even cult healing practices. These factors, coupled with a poor health-insurance system and a social need for gainful employment, have reduced the need for formal institutes of psychoanalysis and explain why the Philippines at the moment has no training analysts practicing psychoanalysis. Freud's work has not made a big impact in this predominately Catholic culture, where even today, teaching human sexuality from the point of view of psychology has not gained much ground in the academic world. Sex education consists largely of lectures on population control.

GEOFFREY H. BLOWERS

### Bibliography

Estrada-Cristanto, T. (1997). Interview with Virgilio Santiago. November. Manila, Philippines. Unpublished. Lapuz, Lourdes. (1969). *A study of psychopathology*. Quezon City, Philippines: New Day Publications.

Lapuz, Lourdes. (1973). *Children of Oedipus*. Quezon City, Philippines: New Day Publications.

———. (1979). *Marriage counselling*. Quezon City, Philippines: New Day Publications.

Santiago, Virgilio. (1966). Psychopathology of Sisa. *Acta Medica Philippina*, 2 (3), 140–145.

## PHILIPPSON BIBLE

Sigmund Freud's father Jakob Freud (1815–96) came from a Hassidic community in Tysmenitza, in Galicia. He familiarized his son Sigmund, from age seven, with Ludwig Philippson's Hebrew Bible, in a richly illustrated, bilingual Hebrew-German edition.

In all probability, he had acquired the second edition, published in 1858, at the establishment of Baumgärtner, a bookseller in Leipzig, during the family's trip from Freiberg to Vienna with little Sigismund, then three years old. Jakob inscribed in this Bible the date of the death of his own father, Schlomo, along with the following: "My son Sigmund Schlomo was born on Tuesday, the first day of Iar 616 at 6:30 in the afternoon, or 6 May 1856. He entered into the Jewish Covenant on Tuesday 8 Iar, or 13 May 1856. The Mohel was Rabbi Samson Frankl."

Jakob Freud had this Bible rebound in leather in 1891 and gave it to Sigmund for his thirty-fifth birthday with a dedication, written in Hebrew characters, that is a mosaic of sentences excerpted from the Bible, the Talmud, and the Jewish liturgy, showing that he was a learned Jew and an expert in biblical reading. According to a study by Yosef Hayim Yerushalmi, the heritage this dedication holds is a coded message from the father, seventy-seven years old at the time, advocating a return to the Bible as a source of creative inspiration. There is some discord between, on the one hand, the knowledge and meaning evident in the dedication, which display a biblical spirit; and on the other the rationalist tenor of the Philippson Bible, which is infused with the spirit of the Enlightenment, even if the Hebrew text itself, bears a traditional orientation. Freud himself, in a 1935 addendum to "An Autobiographical Study" (1925 [1924]), revealed the impact this early reading had on him: "My deep engrossment in the Bible story (almost as soon as I had learnt the art of reading) had, as I recognized much later, an enduring effect upon the direction of my interest." (p. 8).

The critique of religion elaborated in Freud's scientific writings originated in his youth, but his affirmations relating to his Jewish identity and his belonging to the Jewish people are an integral part of his life story, from his earliest years to his last days.

EVA LAIBLE

See also: Freud, Jakob Kollomon (or Keleman or Kollomon); Judaism and psychoanalysis.

## Bibliography

Freud, Sigmund (1925 [1924]). An autobiographical study. *SE*, 20: 1–74.

Grosz, Ronald. (1992). *Das jüdische element in Freuds psychoanalyse*. Dissertation zur Erlangung des Doktorgrades der Philosophie an der Grund-und Integrationswissenschaftlichen Fakultät der Universität Wien. Vienna, dissertation.

Yerushalmi, Yosef Hayim. (1991). *Freud's Moses: Judaism terminable and interminable*. New Haven and London: Yale University Press.

## Further Reading

Yerushalmi, Yusef Hayim. (1991). *Freud's Moses: Judaism terminable and interminable*. New Haven and London: Yale University Press.

## PHILOSOPHY AND PSYCHOANALYSIS

The relations between psychoanalysis and philosophy are close, complex, and full of conflict. Freud, Lacan, and a few other writers assuming a psychoanalytic viewpoint persistently situated themselves in relation to philosophy, making use of it and explaining psychoanalytic terms by reference to it. For their part, philosophers have regarded psychoanalysis with a mixture of fascination and suspicion, and have subordinated it to the needs and objectives of philosophy, which has allowed them to contest or reject it.

The meaning and scope of Freudian enquiry have been evaluated differently by the two disciplines. For Freud, philosophy has repeatedly been concerned with the question of the unconscious. Indeed, thinkers before Freud have posited the unconscious. In the philosophic tradition, however, either the unconscious is mystic and impossible to grasp, so that its relation to the psyche remained buried in obscurity (Eduard von Hartmann and the Romantics), or the psyche was identified with consciousness (René Descartes, Franz Brentano), with the result that psychological investigation overlooked the unconscious. These philosophers misunderstood unconscious mental activity. They did not suspect to what extent unconscious "phenomena" (primary and secondary processes, the processes of the id and the ego) were similar to and yet different from conscious phenomena.



Freud exposed the paradox of the philosopher, caught between the wish for a totalizing and unifying vision and the need to put an individual stamp on his work. Freud believed that psychoanalysis could expose the subjective and individual motivations behind philosophical doctrines that claimed to result from an impartial effort of logic (see his derivation of systems from two sources in *Totem and Taboo* [1912–1913a]). Psychoanalysis can also demonstrate the weak points of a philosophical system. There is a link among these two findings, the singular focus of philosophy on “conscious awareness,” and the uncovering of philosophical paradox. To acknowledge unconscious processes is to recognize the impossibility of any pure transparent knowledge of the world and of thought to itself. Less negatively, on the interpretation of art proposed by Freud, philosophy could be considered an intellectual work of art.

Nonetheless, Freud maintained that psychoanalysis is a natural science with a specific object. For it has an empirical content that is experienced in everyday psychic phenomena and in analysis and that is manifested in ways governed by a determined protocol: unconscious mental processes, infantile sexuality and the Oedipal structure, transference, resistance, and repression. This same content can be grasped a posteriori in fundamental concepts and coordinated in a theory that Freud called “metapsychology.” As distinct from biology and psychology, metapsychology refers to a psychology that runs up against the unconscious. Freud did not hesitate to apply such conceptions to Immanuel Kant’s thought by suggesting, for example, that the superego is the metapsychological version of the categorical imperative. As for the death instinct, Freud noted the differences but also the proximity of his concept with that of Arthur Schopenhauer.

Yet psychoanalysis wanted to go further. It seeks to “translate metaphysics into metapsychology,” that is, not only to capture the subjective motivation of a philosopher but to propose a global interpretation of mental life, one of the most fundamental aspects of philosophy. For psychoanalysis, the mental process takes place in three stages: “endopsychic perceptions,” including unconscious psychic phenomena, supply an “obscure awareness”; this is objectified by projection onto the outside world and is reflected in the construction of a supersensible world; finally, metapsychology translates this supersensible metaphysical world into a psychology that takes unconscious processes into account (Assoun, 1976).

At the same time, Freud downplayed his knowledge of philosophers, especially Friedrich Nietzsche—whether from fear of being dispossessed of his discovery or from real ignorance, it is difficult to say, especially given the ambiguous link that connects Freud to philosophy and science. Freud, who was initially very interested in philosophical thought (1985), attempted to reconcile in metapsychology (which he called “the metapsychological sorceress”) his enthusiasm for speculation and the requirements of scientific practice.

It must be pointed out that Freud never contested the primacy of consciousness. For although the unconscious is located at the juncture of the psyche and the body, it is inaccessible via the body. Therefore, it must be approached by the only avenue left open to us: consciousness. It is through the data of consciousness, and principally language, that we are able to infer unconscious processes.

Throughout his life, the French psychoanalyst Jacques Lacan always engaged with philosophy and philosophers. The landscape and aims of psychoanalysis have changed since Freud, but a secret heritage remains. Lacan could rightly claim, “What I tried to do with my Borromean knot is nothing less than the first philosophy that seemed likely to me to hang together.” He referred to philosophy as an “irreparably mistaken path,” against which psychoanalysis affirms its belief in the unconscious. But his differences from Freud are considerable. Lacan’s originality can be traced, at least partially, to his unique learning. He was grounded in contemporary philosophy and possessed an understanding of modern science, especially linguistics, mathematics, mathematical logic, information theory, and game theory. Such science, profoundly connected to the nominalist current that appeared in European philosophy in the fourteenth century (William of Ockham) and was extended by Descartes and Gottfried Wilhelm Leibniz, tends to separate the sign from the referent, or signified, and to emphasize the value of the signifier. Even though he profoundly distorts the meaning of the concepts he borrows from philosophy and science, Lacan can be understood only if the origin of those concepts is properly situated: the concept of the signifier arose in linguistics and nominalist thought, that of the real in its opposition to the world arose from Martin Heidegger’s concept of being-in-the-world (*Dasein*), that of the other and the big Other (the primary caregiver) arose in reference to the work of Georg Wilhelm

Friedrich Hegel. Also important is philosophical thinking on alterity (otherness) in general (from Plato to Hegel and Emmanuel Levinas [1906–1995]).

Indeed, it is difficult to talk about desire (a concept foreign to Freud) without recalling the discourse of master and slave, about the subject without reference to Descartes, or about the thing without reference to Heidegger's or Kant's notion of the thing-in-itself. But aside from his concepts, Lacan's project, although not metapsychological, is to form a distinct psychoanalytic discourse that diverges from university discourse, to which philosophical discourse is assimilated (see Lacan's theory of the four discourses [1991]). Through the construction and study of Borromean knots, Lacan felt he was able to achieve what Freud had foretold: "There is a place beyond the Oedipal complex, where we enter into the reality test and where we experience a *jouissance* [enjoyment] beyond the pleasure principle." Lacan felt he had written the much sought-after philosophical discourse—a discourse that possessed, if not scientific rigor, at least philosophical rigor (Juranville, 1984).

We again face the ambiguity confronted at the start: the nature of the subject. Here the point of disagreement between philosophy and psychoanalysis has to do with the subject that engages in these discourses: even if the subject of the unconscious is the Cartesian subject (philosophical discourse), that subject, as conceived by Lacan, has been divided, separated, and split (psychoanalytic discourse). Lacan's relation to philosophy is original and singularly complex. It is impossible to adjust to the needs of psychoanalysis the logic of the signifier (for which Lacan's use of Borromean knots is the ultimate extension) and Freud's discovery of the unconscious without a misappropriation of philosophy, principally Descartes's "Cogito, ergo sum" (I think; therefore I am) (Lacoue-Labarthe & Nancy, 1992).

Psychoanalysis always appears to the philosopher as a source of the uncanny, which is difficult to integrate in rational thinking. How can one practice philosophy after Freud? asked Monique Schneider (1989). There has been a dizzying array of responses to this question; here it will suffice to sketch a few of the main arguments. The point of view generally adopted is that of the unconscious, which naturally cannot be introduced without placing limits on the question. Marxists (Georges Politzer, Herbert Marcuse), phenomenologists (Eugen Fink, Jean-Paul Sartre, Maurice Merleau-Ponty),

hermeneuticians (Paul Ricoeur), philosophers of the 1960s (Gilles Deleuze, Jean-François Lyotard, Jacques Derrida, Michel Henry), Ludwig Wittgenstein and his commentators (Jacques Bouveresse), philosophers of science (Karl Popper, Adolf Grünbaum), analytic philosophers (in France, Pascal Engel, Centre de recherche en épistémologie appliquée [Center for Research in Applied Epistemology]) have all developed a discourse on psychoanalysis and the unconscious. Some of their criticism is directed at the scientific status of psychoanalysis, which is violently rejected by Popper, Grünbaum, and Bouveresse. Others, such as Ricoeur, felt they could demonstrate its validity by treating it as a form of hermeneutics. Marcuse saw psychoanalysis as an instrument of sexual liberation. Deleuze saw it as an instrument of destruction: "In opposition to psychoanalysis I have claimed only two things: it breaks everything produced by desire, it crushes every utterance. By doing so it shatters both sides of the arrangement: the mechanistic articulation of desire and the collective articulation of utterance." Lyotard made brilliant use of the concepts developed by Freud in *The Interpretation of Dreams* (1900a) to construct an aesthetic philosophy. Others, like Henry in *Généalogie de la psychanalyse* (1985) or Jean-Marie Vaysse in *L'inconscient des modernes* (1999), attempt to demonstrate how Freud's thought derived from Descartes "Cogito, ergo sum," as it did for Benedict de Spinoza, Leibniz, Schopenhauer, and Nietzsche. Jacques Derrida is a separate case. Even though, like his predecessors, he feels that only his principal concepts (here *différence* [difference], *archi-écriture* [original writing], deconstruction) are capable of addressing the arguments of psychoanalysis, among philosophers he remains, together with Lyotard, one of the most knowledgeable about psychoanalysis and, since the 1970s, one of the most engaged with psychoanalysis.

The difficult relations between philosophy and psychoanalysis arise primarily from the fact that both investigate the same field, human experience (including sexuality, life, death, suffering, relations with the world in culture and work) but operate within this field according to opposite principles, consciousness in the case of philosophy and the unconscious in the case of psychoanalysis. The unconscious is expressed in everyday life but is especially present during analysis, where transference and resistance occur. Except for Derrida (1987; 1998), most authors do not really consider the reality of transference and its paradoxical nature. One thing is certain, however. A dialogue with philosophy and epistemology will enable psychoanalysis to better

understand its ambiguous status, which falls somewhere between science and fiction.

BERNARD LEMAIGRE

*See also:* Alterity; “Claims of Psychoanalysis to Scientific Interest;” Cognitivism and psychoanalysis; Determinism; Dualism; Four discourses; Hermeneutics; Kantianism and psychoanalysis; Merleau-Ponty, Maurice; Monism; Perceptual identity; Phenomenology and psychoanalysis; Primary process/secondary process; Psychoanalytic epistemology; Sartre and psychoanalysis; Thought identity; Unconscious, the.

### **Bibliography**

- Assoun, Paul-Laurent. (1976). *Freud, la philosophie et les philosophes*. Paris: Presses Universitaires de France.
- Bouveresse, Jacques. (1991). *Philosophie, mythologie et pseudo-science: Wittgenstein lecteur de Freud*. Combas, France: Éclat.
- Derrida, Jacques. (1987). *The post card: From Socrates to Freud and beyond* (Alan Bass, Trans.). Chicago: University of Chicago Press.
- . (1998). *Resistances of psychoanalysis* (Peggy Kamuf, Pascale-Anne Brault, and Michael Naas, Trans.). Stanford, CA: Stanford University Press.
- Freud, Sigmund. (1900a). The interpretation of dreams. *SE*, 4: 1–338; 5: 339–625.
- . (1912–1913a). Totem and taboo. *SE*, 13: 1–161.
- . (1985). *The complete letters of Sigmund Freud to Wilhelm Fliess, 1887–1904* (Jeffrey Moussaieff Masson, Trans.). Cambridge, MA: Harvard University Press.
- Henry, Michel. (1985). *Généalogie de la psychanalyse: Le commencement perdu*. Paris: Presses Universitaires de France.
- Juranville, Alain. (1984). *Lacan et la philosophie*. Paris: Presses universitaires de France.
- Lacan, Jacques. (1991). *Le séminaire*. Book 17: *L'envers de la psychanalyse (1969–1970)*. Paris: Seuil.
- Lacoue-Labarthe, Philippe, & Nancy, Jean-Luc. (1992). *The title of the letter: A reading of Lacan* (François Raffoul and David Pettigrew, Trans.). Albany: State University of New York Press. (Original work published 1973)
- Schneider, Monique. (1989). *Philosopher après Freud. L'univers philosophique: Encyclopédie philosophique universelle* (pp. 720–731). Paris: Presses universitaires de France.
- Vaysse, Jean-Marie. (1999). *L'inconscient des modernes: Essai sur l'origine métaphysique de la psychanalyse*. Paris: Gallimard.

### **Further Reading**

- Grunbaum, Adolph. (1993). *Validation in the clinical theory of psychoanalysis: A study in the philosophy of psychoanalysis*. Madison, CT: International University Press.
- Holt, Robert. (1997). *Psychoanalysis and the philosophy of science*. Madison, CT: International University Press.
- Lear, Jonathan. (1990). *Love and its place in nature: A philosophical interpretation of freudian psychoanalysis*. New York: Farrar, Straus & Giroux.

---

## **PHOBIA OF COMMITTING IMPULSIVE ACTS**

A phobia of impulsive acts is the fear of a sudden desire to commit an auto- or heteroaggressive act. This sudden desire is accompanied by anxiety stemming from a neurotic disorder within the sexual economy. Two types are generally described: defenestration phobias and phobias of knives; impulsive phobias of a sexual nature have also been described. The aggressive valence and symbolic nature of such phobias are obviously in the foreground.

In psychiatry, the term *phobia of impulsive acts* appeared at the end of the nineteenth century, in the midst of a catalog of more than two hundred phobias. Initially, phobias were not greatly differentiated from obsessive ideas. Philippe Pinel described “manias without delusions”; Jean-Étienne Esquirol placed them within the “monomanias” along with the notion of “obsessive fears.” The notion of phobia per se appeared only in 1871, with agoraphobia (Karl Westphal). At the beginning of the twentieth century, phobias, still largely undifferentiated from obsessions, were thought to arise from hyperemotivity. In *Les Obsessions et les Impulsions* (Obsessions and impulses; 1902), Albert Pitres and Etienne Régis emphasized the fact that any phobia can become obsessive and placed these phobias of impulsive acts in the category “obsessions-impulses.” The similarity between phobia and obsessional neurosis was pursued by Emil Kraepelin and Pierre Janet. Sigmund Freud, too, through his clinical examples, gave the impression of placing them alongside obsessional manifestations.

The syndrome of the phobia of impulsive acts is situated between hysterical anxiety and the modes of obsessive organization. The most frequent forms are defenestration phobia (“I’m afraid of wanting to throw myself out of the window”) and phobias of knives. The phobic subject consciously fears what he

unconsciously desires; he perceives his desires as being alien to himself. Sometimes it is objects that become phobogenic, dangerous, and to be avoided at all costs (“I’m afraid of hurting my child with a knife”). These phobias generate anxiety because they stage fantasies of narcissistic fusion with the forbidden oedipal object. If the primary object brings security, why not throw oneself into its arms, enter into it? If it is oedipal, sexually desirable, why not become one with it? (Bayle, Gérard, 1997). The failure of repression cannot mask feelings of ambivalence; defenses are formed against loss of identity and the threat of castration. But in contrast to simple phobias, the subjects of the phobia of impulsive acts fear actions coming from themselves. They feel inadequately protected against their own impulses, and to defend themselves, resort to avoidance tactics that use a protective third party, enabling them to bolster their weakened narcissism. In “Contribution à l’étude des phobies” (Contribution to the study of phobias; 1956), Jean Mallet showed that a perceived absence of parental protection is an essential component in the choice of phobia.

Phobias of impulsive actions are to be considered not so much a symptom as an element to be situated in relation to the structure, history, and fantasies of the subject. Their outcomes are variable, depending on whether they involve an oedipal conflict or issues that are more narcissistic in nature. The conflict of ambivalence is always present, and obsessions will appear if anxiety and aggression overpower the ego’s phobic defenses. Moreover, a phobia of obsessive acts may appear prior to a psychotic decompensation.

CHRISTIANE GUITARD-MUNNICH AND PHILIPPE TURMOND

*See also:* Phobic neurosis.

### **Bibliography**

- Bayle, Gérard. (1997). Considérations sur la clinique des phobies névrotiques. In *Peurs et Phobies*. (p. 113–133). Paris: Presses Universitaires de France.
- Conté, Claude; and Perrier, François. (1968). Névrose phobique. In *Encyclopédie médico-chirurgicale*, Vol. *Psychiatrie*. (p. 37–360). Paris: E.M.-C.
- Freud, Sigmund. (1895 [1894]). On the grounds for detaching a particular syndrome from neurasthenia under the description “anxiety neurosis.” *SE*, 3: 85–115.
- Mallet, Jean. (1956). Contribution à l’étude des phobies. Rapport à la XVIIIe Conférence des psychanalystes de

langues romanes, Paris, 1955. *Revue Française de Psychanalyse*, 20, 1–2, 237–82.

### **Further Reading**

- Blum, Harold P. (1976). Acting out, the psychoanalytic process, and interpretation. *Annual of Psychoanalysis*, 4, 163–184.
- Boesky, Dale. (1982). Acting out: A reconsideration of the concept. *International Journal of Psychoanalysis*, 63, 39–56.

---

## **PHOBIAS IN CHILDREN**

A phobia (from the Greek *phobos*: “flight, fear, fright”) is an irrational fear aroused by an object, situation, or activity that does not involve real danger. Anxiety, the irrationality of which is generally consciously recognized by the person, results in various defensive strategies: flight, avoidance, or the use of an object or person that enables the subject to face the feared situation.

The term first appeared in the psychiatric literature of the late nineteenth century (Karl Westphal, in 1872, cited agoraphobia); French psychiatrists around the same time (Albert Pitres and Emmanuel Régis) described a very large number of phobias in terms of the triggering object or situation (claustrophobia, erythrophobia, zoophobia, etc.).

Pierre Janet, who linked phobic symptoms to psychasthenia, divided phobias into three categories that remain in use: object phobias, situation phobias, and function phobias. Object phobias involve pointed or cutting objects (scissors, knives, razor blades) associated with auto- or heteroaggressive fantasies that may take the form of phobias of impulsive acts and that are often integrated into obsessional neurosis. Similar to these are phobias of animals, which are very frequent in children but can continue into adulthood (fear of spiders, mice, snakes, birds, etc.).

Situation phobias involve open spaces (agoraphobia), enclosed spaces (claustrophobia), or high places (vertigo). In function phobias, manifest anxiety bears upon the functioning of the organism: fear of falling asleep or of swallowing. Similar to these are the fear of diseases (nosophobia) and social phobias: fear of speaking or blushing in public (erythrophobia), and phobias of touching or contact.

The term *pantophobia* is sometimes used to describe a diffuse anxiety aroused by several objects or

situations, but the absence of specific conditions for the emergence of anxiety makes the inclusion of such cases in the framework of the phobias questionable. Certain phobic behaviors can be likened to the rituals seen with obsessional neurosis (mixed, so-called phobo-obsessional forms).

The clinical study of phobias would be incomplete if it did not consider the behaviors that the person uses to fight against the anxiety associated with the phobogenic object. These behaviors derive from two types of defensive strategy: avoidance and reassurance. Avoidance can be expressed in maneuvers to flee or bypass the phobogenic situation or through varying degrees of restriction in the subject's activities. Reassurance enlists a person or object that makes it possible to face the phobogenic situation.

The understanding of phobias is one of the very earliest topics to engage Sigmund Freud's theoretical reflection, as early as 1894–1895. One of his first articles on this theme, "Obsessions and Phobias: Their Psychological Mechanism and Their Aetiology" (1895c [1894]), originally published in French, discussed Janet's conceptions and clearly separated phobias from obsessions: in particular, the relation to anxiety is specific to phobias. In these early works, Freud considered the phobias as a form of anxiety neurosis, which he classed among the "actual" or defense neuroses and whose etiology he explained in terms of an accumulation of endogenous excitation, "a veritable self-intoxication, by means of a sort of engorgement of the sexual substances."

In his later writings, he linked phobias to hysterical anxiety and thus to the transference neuroses that are accessible to analysis. In hysterical anxiety, the libido is unleashed in the form of anxiety and not converted as would normally happen in hysteria. Repression bears upon an instinctual impulse with projection onto an object; anxiety cannot be totally avoided except at the cost, as Freud noted, of "all sorts of inhibitions and restrictions" to which the person must submit him- or herself.

Freud developed his notion of the formation of phobias in the case of Little Hans, related in "Analysis of a Phobia in a Five-Year-Old Boy" (1909b), and in his return to that case in that of the Wolf Man in "Inhibitions, Symptoms and Anxiety" (1926 [1925]). The symptom results from mental work that aims to "fix once again the anxiety that has become free."

Freud showed how Little Hans's phobia of the horse staged the representation of the threat of castration by the father figure. At the same time, through the motor inhibition it entailed in the child, the phobia realized a compromise between the incestuous desires directed toward the maternal object and their repression (prevented by his phobia from going out, the boy could remain near his mother). Repression affects the totality of the components of the Oedipus complex.

Returning to this case in 1926, while maintaining the central role of castration anxiety, Freud placed greater emphasis on the repression of parricidal fantasies, as well as on the passive homosexual fantasy of the father figure. The phobia could be understood as an attempt to resolve the conflict of ambivalence: Little Hans's symptom was a compromise between love and hostility for the father. The displacement onto another object of the anxiety that results from a conflict of ambivalence protects the ego from instinctual danger. In this work Freud underscored the reversal that analysis of the formation of phobias had compelled him to make in his theory of anxiety: It is anxiety that is at the origin of repression, and not the reverse.

In the subsequent development of psychoanalysis, phobias in children have incited numerous theoretical debates. Anna Freud and her followers differentiated between phobias and the archaic fears that preexist all earlier experiences (fear of the dark, of storms, etc.). For these authors, these infantile fears, merely an expression of the ego's immaturity, were not phobias in the strict sense, in that they did not bring together condensation, projection, and symbolization. However, they considered such fears to be the precursors to phobias. These authors believed that was not possible to speak in terms of a neurotic organization before conflicts had been internalized at the end of the Oedipus complex.

According to Melanie Klein, the primitive Ego is subjected to experiences of intense anxiety. Phobia corresponds to the projection of the death instinct onto external objects; it comes about in relation to the forming of object relations and the emergence of a terrifying, archaic superego that is identified with the paternal penis. This destructiveness, projected onto the introjected parents, constitutes the internal threat that is the source of phobias. Archaic anxiety produces fantasies of being devoured; phobias of animals, especially, represent the fear of being devoured by the superego. However, the phobia also expresses a sadistic

destructiveness that is linked to aggression directed toward the paternal imago; the violence of this destructive impulse is the source for massive anxiety that, in turn, becomes a source of persecution.

In 1956–1957 Jacques Lacan introduced the notion of the phobic signifier, the equivalent of the paternal metaphor that makes it possible to symbolize the Real of phallic *jouissance*. The phobogenic object masks the subject's fundamental anxiety and comes to occupy an intermediate position between the phallic signifier and an appeal to the Name-of-the-Father. Whereas the fetish object, in perversion, is the absolute condition for *jouissance*, the function of the phobic signifier is to protect the subject from the disappearance of desire.

Although castration anxiety does indeed appear to be central in phobias, the affect that characterizes it seems to originate in the experience of separation. The absence of the mother, in the preverbal infant's situation of helplessness and distress (*Hilflosigkeit*), creates the traumatic conditions for terror (*Schreck*). The defensive mechanisms put into place to cope with this can be seen as the precursors to the organizing mechanisms of phobia. According to Annie Birraux in *Éloge de la phobie* (In praise of phobia, 1994), phobia is “a primitive structure of thought”: Projection, one of its fundamental mechanisms, is to be linked to the primitive movement of expulsion that Freud, in “Negation” (1925h), placed at the origins of the coming into being of the subject and the activity of thought.

From a clinical viewpoint, Jean Mallet, in “Contribution à l'étude des phobies” (Contribution to the study of phobias, 1956), described the development of phobias in children as a function of age. He showed the continuity between the child's archaic fears and the phobias proper of the oedipal period. The prototype of phobia can be seen at around eight months in the child's negative reaction to the approach of a stranger; according to René Spitz, this reaction expresses the child's accession to a total object relation and thus to the experience of separation. This issue becomes the basis for the organization of the fears and phobias (or prephobias, according to some authors) of the pregenital period.

Anxieties often manifest during sleep or at bedtime: fear and refusal to go to bed (the transitional object can be considered as a precursor to the counterphobic object), or nightmares, which Mallet linked to night

terrors. Around the age of two, dream imagery takes the form of large animals that can bite or devour, and which translate fantasies related to orality—the source, according to Mallet, of the phobias of large animals that often occur around this age. Later, the shift toward phobias of small animals—a source of repulsion rather than fear, and with which the child avoids visual or tactile contact—coincides with entrance into the genital stage. These phobias can be understood as an expression of the prohibition against the voyeuristic impulses and touching, and more generally against sexual curiosity.

School is one of the main places where phobic manifestations occur. While some intellectual inhibitions can be related to castration anxiety and oedipal issues, most anxiety disorders centering on school are connected to difficulties of separation, whether in the form of transitory—although sometimes extremely intense—reactions against the early experience of being in school, or more serious and persistent phobias relating to school. Serge Lebovici has emphasized that serious school phobias appearing later in life (in preadolescence or adolescence) are often congruent with a prepsychotic organization. This underscores the heterogeneous nature of phobic manifestations in children and the need for a psychopathological evaluation of the developmental and structural context in which these manifestations emerge.

CLAUDE BURSZEJN

*See also:* Phobic neurosis.

### **Bibliography**

- Birraux, Annie. (1994). *Éloge de la phobie*. Paris: Presses Universitaires de France.
- Cyssau, Catherine. (1997). La peur et les phobies: des névroses d'angoisse à l'hystérie d'angoisse. In *Peurs et phobies* (A. Fine, A. Le Guen, and A. Oppenheimer, Eds.). Paris: Presses Universitaires de France.
- Freud, Anna. (1977). Fears, anxieties, and phobic phenomena. *Psychoanalytic Study of the Child*, 32, 85–90.
- Freud, Sigmund. (1895c [1894]). Obsessions and phobias: their psychical mechanism and their aetiology. *SE*, 3: 69–82.
- . (1909b). Analysis of a phobia in a five-year-old boy. *SE*, 10: 1–149.
- . (1925h). Negation. *SE*, 19: 233–239.

———. (1926d [1925]). Inhibitions, symptoms and anxiety. *SE*, 20: 75–172.

Mallet, Jean. (1956). Contribution à l'étude des phobies. Rapport à la XVIIIe Conférence des psychanalystes de langues romanes, Paris, 1955. *Revue Française de Psychanalyse*, 20, 1–2, 237–282.

Valentin, Éric. Les phobies chez l'enfant. *Perspectives Psychiatriques*, 4, 265–319.

## PHOBIC NEUROSIS

Phobic neurosis, referred to by Sigmund Freud as “anxiety hysteria,” is characterized by anxiety focusing on certain external objects, be they things, persons, or situations. It is essentially a castration anxiety caused by an oedipal scenario. This distinguishes phobic neurosis from other, less serious situations. Beginning with “The Neuro-Psychoses of Defence” (1894a), Freud gave a fairly clear definition of the phobias, which he connected, in part, to hysteria, and which he distinguished from obsessions. In contrast to the so-called “actual” neuroses, which have a contemporaneous sexual dysfunction in their etiologies, he related obsessions and hysterias to an intrapsychic conflict with roots in childhood sexual history. In the case of an obsession, the sexual idea is later divorced from the corresponding affect; in the case of “hysterophobia,” the sexual idea, because of repression, disappears from consciousness only to reappear in the form of anxiety linked to another idea. The sexual idea is maintained with the earlier one by means of surreptitious links, which psychoanalysis can reveal.

This first theory of anxiety, which Freud developed in the context of the first topography between 1895 and 1900, is, as Jean Laplanche pointed out (1980), an economic theory. In “Analysis of a Phobia in a Five-Year-Old Boy” (1909b), Freud stated that Little Hans’s phobia corresponded to a repressed libidinal longing and emphasized the irreversible character of this transformation. Even if the longing could later be satisfied, it “can no longer be completely retransformed into libido; there is something that keeps the libido back under repression” (p. 26). In an attempt to clarify this imprecise understanding, Freud, after elaborating the second topography and returning to his reading of the case of little Hans in “Inhibitions, Symptoms, and Anxiety” (1926d [1925]), reversed his earlier formulation: “The anxiety felt in phobias is an ego anxiety and arises in the ego, and ... it does not proceed out of repression but,

on the contrary, sets repression in motion” (p. 110). As to the origin of this anxiety, Freud concluded with a “Non liquet!” (“It is unclear”).

Melanie Klein further developed this line of thinking in light of the death instinct hypothesized by Freud in 1920. As Hanna Segal wrote in 1979, “For her part, Melanie Klein believes that anxiety is a direct response to the internal work of the death instinct.” The phobic defenses are erected against unconscious fantasies, which are linked to the death instinct, in an attempt to control the external objects; this attempt is proportional with other attempts to exercise omnipotent obsessive control over internal objects. Even a succinct discussion of the place of these concepts in Klein’s metapsychology would require developing other ideas, notably those connected with the hypothesis of the internalization of an early archaic superego. Klein’s case study of “Richard” illustrates this problem.

The category of phobic neurosis, under the heading “phobic anxiety disorders,” appears in the World Health Organization’s *Classification of Mental and Behavioural Disorders*, in *International Classification of Diseases (ICD-10)*, in a purely descriptive and behavioral formulation. Because of the polymorphism of phobias, this category brings with it a marked risk of imprecise diagnoses. By contrast, the *Classification française des troubles mentaux de l'enfant et de l'adolescent* (French classification of childhood and adolescent mental disorders, Roger Misès), appears to maintain clear distinctions among the different phobic symptomatologies and the related neurotic structures.

The existence of such a “neurotic phobic structure” has been contested by some authors, notably Jean Bergeret. On another level, Jacques Lacan, in his seminar on object relations (1994) based on the case of Little Hans, introduced the notion of the phobic signifier. This reflection led him to reject the idea of a “phobic structure” in favor of a conception that made phobia a crucial moment that can be turned into hysteria, obsession, or perversion.

René Spitz’s work on the “fear of strangers” as the “second organizer” in babies was also carried out from a perspective marginal to the current of thought supporting neurotic structures. In the 1990s there was an inquiry into metapsychologically extending the concept of the phobic to adolescents, as well as an inquiry into whether phobias are a primal structure (Birraux).

FRANCIS DROSSART

See also: “Analysis of a Phobia in a Five-year-old Boy” (Little Hans); Anxiety; Castration complex; *Inhibition, Symptoms, and Anxiety*; “Neurasthenia and Anxiety Neurosis”; Neuro-psychosis of defense; Neurosis; Phobia of committing impulsive acts; Phobias in children; Prepsychosis; Projection; Symptom-formation.

### Bibliography

- Birraux, Annie. (1994). *L'éloge de la phobie*. Paris: Presses Universitaires de France.
- Freud, Sigmund. (1894a). The neuro-psychoses of defence. *SE*, 3: 41–61.
- . (1909b). Analysis of a phobia in a five-year-old boy. *SE*, 10: 1–149.
- . (1926d [1925]). Inhibitions, symptoms, and anxiety. *SE*, 20: 75–172.
- Klein, Melanie. (1961). *Narrative of a child analysis*. London: Hogarth.
- Lacan, Jacques. (1994). *Le séminaire*. Book 4: *La relation d'objet (1956–1957)*. Paris: Seuil.
- Perrier, François (1956). “Phobies et hystérie d'angoisse.” *Psychanalyse*, 2, 165–196.
- Segal, Hanna. (1979). *Melanie Klein*. New York: Viking Press.

### Further Reading

- Compton, Allan. (1992). The psychoanalytic view of phobias Part I.: Freud's theories of phobias and anxiety. *Psychoanalytic Quarterly*, 61, 206–229.
- . (1992). The psychoanalytic view of phobias Part II.: Infantile phobias. *Psychoanalytic Quarterly*, 61, 230–256.
- . (1992). The psychoanalytic view of phobias Part III. Agoraphobia and other phobias of adults. *Psychoanalytic Quarterly*, 61, 400–425.
- . (1992). The psychoanalytic view of phobias Part IV. General theory of phobias and anxiety. *Psychoanalytic Quarterly*, 61, 426–448.
- Lichtenberg, Joseph D. (1991). Fear, phobia, and panic. *Psychoanalytic Inquiry*, 11, 395–415.

## PHYLOGENESIS

Freud used the term *phylogenesis* to encompass the process of human evolution from its earliest origins. He hypothesized that individual development (ontogenesis) repeats the main stages of evolution, with the

traumatic events in the history of humanity thus reappearing and having a structural influence on the individual. This would explain the universality of primal fantasies, the Oedipus complex, and, more globally, a general outline for the development and functioning of the human psychical apparatus (or psyche).

The idea owes much to Darwin, whom Freud admired from adolescence onward: “The theories of Darwin, which were then of topical interest, strongly attracted me, for they held out hopes of an extraordinary advance in our understanding of the world,” he wrote in “An Autobiographical Study” (1925d [1924], p. 8). The idea appeared with a reference to Darwin in *Studies on Hysteria* (1895d, p. 181) in which, while discussing the symptoms of Elisabeth von R., Freud comments that they “belong to the field of ‘The Expression of the Emotions,’ which, as Darwin has taught us, consists of actions which originally had a meaning” (“originally” here refers to the history of the species) but, Freud adds, civilization has reduced and transposed these expressions symbolically in language.

Freud had already begun reckoning with the axis of time in his early research on the pathways of nerve conduction. He continued to do so in his study of aphasia (where the influence of Hughlings Jackson is notable) and so he quite naturally placed it at the heart of psychoanalysis, in accordance with two axes that he claims to be complementary, ontogenesis and phylogenesis. For Freud, the ontogenetic explanation takes precedence, but reference to phylogenesis may be used to support it, albeit cautiously: “I regard it as a methodological error to seize on a phylogenetic explanation before the ontogenetic possibilities have been exhausted” (1918b [1914], p. 97).

In spite of this reservation, Freud made great use of Haeckel's hypothesis whereby “ontogenesis recapitulates phylogenesis,” and it is worth bearing in mind that his mentor, Carl Klaus, was a fervent disciple of Haeckel. Freud is very explicit in this regard: “Impressive analogies from biology have prepared us to find that the individual's mental development repeats the course of human development in an abbreviated form” (1910c, p. 97), and again (1913f).

Freud made frequent references to phylogenesis in his writings, but it is of central importance in two of them, in which he attempts to paint a vast picture that brings together both the history of the individual and that of humanity in general. In *Totem and Taboo* (1912–13a), which Freud based “upon a hypothesis of



Charles Darwin's upon the social state of primitive men": like apes "men, too, originally lived in comparatively small groups or hordes within which the jealousy of the oldest and strongest male prevented sexual promiscuity" (p. 125). Every human being retains a trace of this domination, which was broken when the sons killed the father: this is the Oedipus complex. And in *A Phylogenetic Phantasy: Overview of the Transference Neuroses* (1985 [1915]), Freud created a sweeping fresco in which he tried to coordinate three stories marked by three temporalities: that of a postulated succession of psychopathological states, that of ontogenesis, and that of phylogenesis (Perron, 1994). In this attempt, conducted jointly with Ferenczi, Freud was in fact more Lamarckian than Darwinian in spite of the discredit that came to bear on Lamarck in the scientific world at the time. Lamarckism informs many passages of his work: in fact, in order to support his hypotheses it was important to believe that individual acquisitions could be preserved and passed on from generation to generation. He often returned to this: "The phylogenetically inherited schemata [...] are precipitates from the history of human civilization [...] This instinctive factor would then be the nucleus of the unconscious" (1918b [1914], pp. 119–120), and again: "Affective states have become incorporated in the mind as precipitates of primaeval traumatic experiences, and when a similar situation occurs they are revived like mnemonic symbols" (1926d, p. 93).

Freud's positions here have received intense criticism for several reasons:

- A certain assimilation of prehistoric man with contemporary "primitive" man and with children, in vogue at the beginning of the twentieth century, is no longer acceptable;
- The "social Darwinism" from which it derives, even if it were based on Darwin's own propositions, has since seen such detestable developments that we are bound to distrust it;
- Most contemporary specialists refute the ethnological and anthropological bases for *Totem and Taboo*;
- Haeckel's hypothesis, which is only very approximately valid in terms of anatomy and physiology, cannot be transposed to behavior, culture, or psychic function without running great risks;
- On his own admission, Freud had recourse to the phylogenetic explanation only when the ontoge-

netic comprehension ran up against the "biological bedrock." When he writes, "All that we find in the prehistory of neuroses is that a child catches hold of this phylogenetic experience where his own experience fails him. He fills in the gaps in individual truth with prehistoric truth" (1918b, p. 97), it is tempting to parody him by saying: "The history of Freudian thought shows that Freud had recourse to the phylogenetic explanation only when the ontogenetic comprehension ran up against the inexplicable. He filled in the gaps in his construction of individual history with prehistoric elements";

- It is important to bear in mind that Freud used the word "phylogenetic" to designate the successive stages in human civilization (supposing, moreover, a single line of development), which implies intraspecific evolution, whereas the term is more usually used to designate interspecific evolution in the succession of living forms;
- Finally, it is difficult to see on what organic bases (postulated each time that Freud had recourse to the notion of "constitution") the transmission could be effected. In this respect, modern research into "intergenerational phenomena" opens the debate concerning means and modes of transmission that correspond more closely to psychoanalytic thought.

ROGER PERRON

*See also:* Biological bedrock; "Claims of Psychoanalysis to Scientific Interest"; Cultural transmission; Darwin, Darwinism, and psychoanalysis; "From the History of an Infantile Neurosis" (Wolf Man); Heredity of acquired characters; Instinct; Ontogenesis; Prehistory; Primal fantasies; Primal, the; Primitive; Primitive horde; Psychic causality; *Thalassa. A Theory of Genitality*; *Totem and Taboo*.

### Bibliography

- Freud, Sigmund. (1910c). Leonardo da Vinci and a memory of his childhood. *SE*, 11: 57–137.
- . (1912–13a). Totem and taboo. *SE*, 13: 1–161.
- . (1913f). The theme of the three caskets. *SE*, 12: 289–301.
- . (1918b [1914]). From the history of an infantile neurosis. *SE*, 17: 1–122.

- . (1925d [1924]). An autobiographical study. *SE*, 20: 1–74.
- . (1926d [1925]). Inhibitions, symptoms and anxiety. *SE*, 20: 75–172.
- . (1985 [1915]). A phylogenetic fantasy: overview of the transference neuroses (Ilse Grubrich-Simitis, Ed., and Axel Hoffer and Peter T. Hoffer, Trans). Cambridge, MA: Belknap Press of Harvard University Press, 1987.
- Freud, Sigmund, and Breuer, Josef. (1895d). Studies on hysteria. *SE*, 2: 48–106.
- Lacoste, Patrick. (1986). “Destins de la transmission”. In *S. Freud: Vue d’ensemble des névroses de transfert* (pp. 165–210). Paris: Gallimard, N.R.F.
- Perron, Roger. (1994). *Une fiction préhistorique de Freud* In A. Fine, R. Perron, F. Sacco (Eds.). *Psychanalyse et préhistoire*. Paris: Presses Universitaires de France.
- Ritvo, Lucile B. (1990). *L’Ascendant de Darwin sur Freud*. Paris, Gallimard. (Original work published 1974)

### Further Reading

- Barchilon, Jose. (2000). Darwin revisited: The phylogeny of emotions. *International Journal of Psychoanalysis*, 81, 328–330.
- Fliess, Robert. (1956). Phylogenetic vs. ontogenetic experience. *International Journal of Psychoanalysis*, 37, 46–60.
- Hoffer, Peter T. (1992). The concept of phylogenetic inheritance in Freud and Jung. *Journal of the American Psychoanalytic Association*, 40, 517–530.

## PHYLOGENETIC FANTASY, A: OVERVIEW OF THE TRANSFERENCE NEUROSES

During World War I, Freud worked on a series of papers on fundamental theoretical issues, intending originally to publish them as a book entitled *Zur Vorbereitung einer Metapsychologie* (Preliminaries to a Metapsychology). He eventually published only five of these papers, including “The Unconscious” (1915e) and “Mourning and Melancholia” (1917e [1915]), in the *Internationale Zeitschrift für ärztliche Psychoanalyse*. From his correspondence, we know that Freud effectively finished the seven other texts, but the projected book never materialized.

Since the seven manuscripts had disappeared without a trace, it was long suspected that Freud had destroyed them. The surprise was general when a manuscript draft of the twelfth in the series was

discovered in 1983 among Sándor Ferenczi’s papers. The work was published in 1985—a facsimile reproduction of Freud’s own manuscript and a printed transcription of it—under the title *Übersicht der Übertragungneurosen. Ein bisher unbekanntes Manuskript* (Overview of the Transference Neuroses. A Hitherto Unknown Manuscript). An English translation followed in 1987.

Freud had sent this draft to Ferenczi for his opinion on July 28, 1915. In the accompanying letter, he specifically stated that the fair copy followed the draft as transmitted to Ferenczi sentence by sentence. The manuscript draft thus gives us a very accurate idea of the lost twelfth metapsychological paper.

The text is clearly divided into two parts. The first sets forth, in telegraphic style, a systematic comparison of the three transference neuroses (conversion hysteria, anxiety hysteria, obsessional neurosis) on the basis of the essential factors involved: repression, anticathexis, symptom-formation, relation to the sexual function, regression, and disposition. True to the promise implied by the title of the draft, this review is based on careful observation and strictly confined to the ontogenetic plane. But once at the sixth factor, namely the role of inherited disposition in the etiology of neurosis, which is almost entirely handwritten, Freud embarks on the speculative adventure of phylogenetic reconstruction (not to say construction). The title is likewise abandoned, as Freud extends his discussion to the “narcissistic neuroses”: dementia praecox, paranoia, and melancholia-mania.

This second part is unquestionably the most groundbreaking section of the draft. The phylogenetic fantasy outlined here may be read as a variation on a theme introduced by Freud in *Totem and Taboo*, the hypothesized murder of the tyrannical father of the primal horde by the sons, giving rise to the sense of guilt as the emotional foundation of emerging civilization. In order to explain the “archaic” inheritance of the mental life of modern man, which is in his view based not only on dispositions but also on actual contents, actual memory traces, Freud postulates a Lamarckian form of hereditary transmission. As scientifically unacceptable as this phylogenetic fantasy is, it presents the greatest interest today, for it may be interpreted as an attempt by Freud, in the context of the etiology of neurosis, to link the model of the drive to the model of trauma by claiming that what are normally considered primal fantasies belonging to psychic

(inner) reality are in fact the product of traumatic events that took place in external reality in prehistoric times.

The discovery of this draft also attests to the close collaboration between Freud and Ferenczi, at the time of its writing, especially with respect to metapsychology and, ultimately, with respect to “psychobiological” themes.

ILSE GRUBRICH-SIMITIS

*See also:* History and psychoanalysis; Metapsychology; Myth of origins; Oedipus complex; Phylogenesis; Processes of Development; *Thalassa: A Theory of Genitality*.

### Source Citation

Freud, Sigmund. (1985 [1915]) *Übersicht der Übertragungsneurosen. Ein bisher unbekanntes Manuskript*. (Ilse Grubrich-Simitis, Ed.) Frankfurt-am-Main: Fischer Verlag; GW, Nachtr., 634–651; (1987) *A phylogenetic fantasy: overview of the transference neuroses*. (Ilse Grubrich-Simitis, Ed.; Axel Hoffer and Peter T. Hoffer, Trans.) Cambridge, MA: Belknap Press/Harvard University Press.

### Bibliography

- Ferenczi, Sandor. (1968) *Thalassa: A theory of genitality*. (Henry Alden Bunker, Trans.) New York: W. W. Norton. (Original work published 1924)
- Freud, Sigmund. (1915e) The unconscious. *SE*, 14: 159–204.
- . (1917e [1915]). Mourning and melancholia. *SE*, 14: 237–258.
- . (1912–13) Totem and taboo. *SE*, 13: 1–161.
- Grubrich-Simitis, Ilse. (1987 [1985]) Metapsychology and metabiology. In Sigmund Freud, *A phylogenetic fantasy* (p. 73–107). Cambridge, MA: Belknap Press, 1987.
- Grubrich-Simitis, Ilse. (1987) Trauma oder trieb. Trieb und trauma. Lektionen aus Sigmund Freuds phylogenetischer Phantasie von 1915. *Psyche*, 41, 992–1023.
- Lacoste, Patrick. (1986) Destins de la transmission. In Sigmund Freud, *Vue d'ensemble des névroses de transfert*. (p. 65–210) Paris: Gallimard.

### Further Reading

- Grossman, William. (1989). Review of A phylogenetic fantasy: overview of the transference neuroses. *Journal of the American Psychoanalytic Association*, 37, 853–858.

Hoffer, Peter T. (1992). The concept of phylogenetic inheritance in Freud and Jung. *Journal of the American Psychoanalytic Association*, 40, 517–530.

---

## PHYLOGENETIC HERITAGE. *See* Cultural transmission

---

## PHYSICAL PAIN/PSYCHIC PAIN

---

Pain is not a concept, but rather a psychical state expressed through localized bodily sensation; as such it is a phenomenon that is currently distinguished from nociception (the electrochemical activity of receptors known as “nociceptors” that react only to bodily stimuli, perhaps of traumatic or inflammatory origin).

The properties of pain have continued to challenge the logical and complex corpus that is Freud’s psychic apparatus, right up to his final works. Thus is pain organic in origin? Is it perhaps the recollection of suffering or a mnemonic symbol for periods of conflict? Pain was also in fact a personal concern for Freud, as it accompanied most of the physical symptoms that afflicted him personally such as migraines, angina, and other cardiac symptoms, but above all the pain in his mouth that appeared around 1899 and which later proved to be cancer. This might explain why he was more interested in cocaine as an analgesic than as an anesthetic.

As early as the “Project for a Scientific Psychology” (1895), where Freud speculates on neuronal and quantitative theory, he acknowledges the limits of this dynamic system and the omissions to his concept of the contact barrier: “Is there a phenomenon which can be brought to coincide with the failure of these contrivances? Such, I think, is *pain*” (Freud, 1895, p.307). When he later directed his research toward the suffering of hysterical patients their physical pain appeared to him to be the product of the conversion of remembered ethical pain into physical pain, owing to their inability to tolerate, at a psychic level, the memory involved. Since it is not always attached to a representation, pain appears to disengage itself from the notion of the symptom in the “Studies on Hysteria” (1895) and consequently Freud decided to use it as a clinical “compass.”

Earlier that same year he had noted that “pain results from a loss” (letter to Wilhelm Fleiss dated January 7, 1895); it comes from a “fixation” (Letter 61, Draft L), and leaves behind “permanent facilitations” (Freud, [1895] 1950, p. 307). This key Freudian hypothesis appears again in his later writings, especially in “Mourning and Melancholia” (1916–1917g [1915]), where the adjective “painful” is characterized as a “mood of mourning” (p. 244). The term “pain,” however, is in fact associated with the two states in question in this text; that is to say, it transcends the categories of normal/pathological and the presence/absence of the lost object in external reality. Freud’s examination, in “On Repression” (1915d), of the fact that an external event produces an internal excitation led him to define pain as a “pseudo-instinct” (p.146). This hypothesis is crucial because it situates pain within the structure of the speaking subject. In “Beyond the Pleasure Principle” (1920) Freud poses the problem of what is bearable and what is unbearable in a radically different way; thus the “specific unpleasure of physical pain,” which “is the result of the protective shield having been broken through in a limited area,” generates an “anticathexis on a grand scale . . . for whose benefit all the other psychical systems are impoverished, so that the remaining psychical functions are extensively paralyzed or reduced” (Freud, 1920g, p. 30).

By virtue of the constancy of its influx, pain is indeed “like” a stimulus coming from within the apparatus that generates an attempt to psychically bind this energy. However, a substantial conceptual change had been effected in that, for Freud, the general problem of the instinctual forces was linked, fundamentally, to the notion of the psychical representative. Pain as a “pseudo-instinct” was thus freed from the economic model that had proven to be too limited, even in terms of its interrelationship with neuropsychology.

Despite his explicit return to the dualism of the instincts in 1926, he could again write: “Pain is thus the actual reaction to loss of object” (1926d [1925] Addendum C). It should be recalled, however, that for him there are no unconscious emotions or affects; it is not pain, but rather lack, that is unconscious.

From the numerous metapsychological reflections on pain it should still be remembered that Freud always insisted that pain should be separated from sadomasochism. For example, he notes here: “Psychoanalysis seems to show that the infliction of pain plays

no role in the primal aims of the instincts” (1926d [1925] Addendum C). To be sure, pain must be conceptualized beyond the pleasure-unpleasure principle, and these hypotheses can lead to the assumption that logically, pain must be anterior to fantasy and to the symptom in the genesis of unconscious formations.

Pain, as a phenomenon, reemerges not according to the processes of remembering (representation) or reminiscence (trauma), but rather from what might be called the “reliving” of an early experience of loss involving an unconstituted object. In this way, the subject would be restored to a state of insignificance.

LAURENCE CROIX

*See also:* Pain.

### **Bibliography**

- Freud, Sigmund. (1950a [1887-1902]). Extracts from the Fliess papers. *SE*, 1: 173–280.
- . ([1895] 1950c). Project for a scientific psychology. *SE*, 1: 295–391.
- . (1916–17g). Mourning and melancholia. *SE*, 14: 237–463.
- . (1920g). Beyond the pleasure principle. *SE*, 18: 7–64.
- . (1926d). Inhibitions, symptoms and anxiety. *SE*, 20: 75–172.
- Freud Sigmund, and Breuer, Josef. (1895d). Studies on hysteria. *SE*, 2: 48–106.

---

### **PIAGET, JEAN (1896–1980)**

Psychologist and theoretician of cognitive development Jean Piaget was born in Neuchâtel, Switzerland, on August 9, 1896. He died in Geneva on September 16, 1980.

Although renowned for his research on the development of intelligence and for his “genetic epistemology,” Piaget was strongly influenced by psychoanalysis in his early career. In his autobiography, Piaget attributed this interest to his mother’s instability and her “rather neurotic temperament.”

By 1912, Piaget had already published taxonomic research on mollusks and developed a background in natural history; he then turned to philosophy. During World War I he went through a period of intellectual crisis dominated by Bergsonian mysticism, which

combined Christian and socialist ideas. One of his first encounters with psychoanalysis occurred in 1916 on the occasion of a lecture on religion and Freudian theory in which Théodore Flournoy stated his agreement with the analytic theory of sublimation while asserting that it must respect the mystery surrounding the ultimate nature of religious phenomena. In *Recherches*, an autobiographical novel about his intellectual apprenticeship, Piaget adhered to the criticisms of Flournoy and the Zurich psychoanalysts; and in his theoretical speculations and analysis of his own character (a young man he identifies as himself) he gave a central role to the concepts of “autism” and “complex,” terms that were originally defined and employed by Eugen Bleuler and the Zurich school. By recasting mystical thought in psychiatric terms, Piaget was able to claim that he both understood it and repudiated it.

Piaget spent the winter semester 1918–1919 at Zurich, where he attended lectures by Eugen Bleuler and Carl Gustav Jung and seminars led by Oskar Pfister. While in Paris in the fall of 1919 he gave a lecture, “Psychoanalysis in Its Relations with Child Psychology”; this became his first publication in psychology and made him one of the first to introduce psychoanalysis to France. He emphasized the importance of psychoanalysis in pedagogy and moral education, but insisted that “unconscious mechanisms” are “the first states of conscious activity.” He also indicated the direction of his early research: correlation of “unconscious development” and “mental development.” In a flattering article published in 1920, Oskar Pfister foresaw a bright future for Piaget as a psychoanalyst.

Piaget joined the Swiss Psychoanalytic Society in October 1920. In 1921 he was hired by the Institut Jean Jacques Rousseau in Geneva, founded by Édouard Claparède and managed by Pierre Bovet. His analyst was Sabina Spielrein, with whom he planned to do research (Vidal). Piaget attended the Seventh International Congress of Psychoanalysis in Berlin in 1922. Circa 1924 he analyzed a student pastor; he may have also have attempted to analyze the student’s mother. He also wrote reports of psychoanalytic works for *The Archives of Psychology*.

During the 1920s Piaget developed the analogy between infantile thinking and “symbolic” or “autistic” thinking, remaining rather closer to his teacher Pierre Janet’s psychology than to Freud’s psychoanalysis. In elaborating parallels between intellectual and emotional development, Piaget critiqued the Freudian

concepts of symbol, memory, and the unconscious. Near the end of his career, Piaget included “the cognitive unconscious” and “the affective unconscious” as a part of a generalized “unconscious” consistent with all that is not conceptualized (1973, p. 31ff).

Piaget retains a place in the history of psychoanalysis, especially in terms of the Genevan “genetic psychology,” and in varied and diverse efforts to link psychoanalysis and the psychology of intelligence—as, for example, in terms of developmental object relations and the concept of object constancy.

FERNANDO VIDAL

*See also:* Adaptation; *Archives de psychologie, Les*; Congrès des psychanalystes de langue française des pays romans; Psychoanalytic epistemology; Société psychanalytique de Paris and Institut de psychanalyse de Paris; Structuralism and psychoanalysis; Unconscious fantasy.

### Bibliography

- Pfister, Oskar. (1920). J. Piaget, “La psychanalyse et la pédagogie.” *Imago*, 6, 3, 294–295.
- Piaget, Jean. (1995). Psychoanalysis in its relations with child psychology. In Gruber, Howard E., and Vonèche, Jacques J. (Eds.). *The essential Piaget*. Northvale, NJ: Jason Aronson. (Original work published 1920)
- . (1973). *Child and reality: Problems of genetic psychology*. New York: Grossman.
- Vidal, Fernando. (1994). *Piaget before Piaget*. Cambridge, MA: Harvard University Press.

---

## PICHON, ÉDOUARD JEAN BAPTISTE (1890–1940)

Édouard Pichon, physician in Parisian hospitals, linguist and psychoanalyst, was born on June 24, 1890, at Sarcelles, just outside Paris, and died in 1940 (he was buried on January 23, 1940).

Originally from Burgundy, Pichon was the son of a notary public at Sarcelles. The family was marked by illness: diabetes on his father’s side and acute articular rheumatism on his mother’s side, from which he, like his sister, would also suffer. Cardiac complications, also shared by his sister, handicapped him throughout his life and were the cause of his death at the age of fifty.

His uncle, Jacques Damourette, who suffered from epilepsy and tuberculosis, also lived in the family

home and introduced his nephew to grammar. Over a period of thirty years they worked together on *Des mots à la pensée* [From Words to Thought], a seven-volume essay on French grammar, as well as a volume of tables and articles for the *Revue de la Philologie Française* [Review of French Philology].

Pichon was a brilliant student, with a special affinity for literature, but, on his father's recommendation, he enrolled for medical studies. At university he met and befriended Théophile Alajouanine. In May 1910, he passed the examination enabling him to become an extern in Parisian hospitals and in 1914 he qualified as an intern under Lereboullet. Louis Aragon, whom he met in the hospitals at this time, described him as "a great pale horse of a man with the typhoid-colored mustache of a thirteen-year-old." He was a lover of obscene songs and linguistics, and kept a notebook where he scrupulously noted all the expressions he heard.

He was a medical officer in the army during World War I and was awarded the Military Cross in 1916. It was during this period that his heart condition first appeared. He became seriously ill, was often hospitalized and handicapped by illness, the inevitable consequences of which were known to him. In 1924 he qualified as a medical doctor after presenting a thesis on "Progressive rheumatic heart disease and its treatment." In 1925 he was appointed clinical director for infantile medicine, first as an assistant at the Saint-Louis Hospital, then, in June 1931, physician to the Parisian hospitals, a prestigious title in which he took great pride.

Through Alajouanine he came to meet Adrien Borel and then René Laforgue, who introduced him to Eugénie Sokolnicka, with whom he began an analysis that lasted from 1923 to 1926. His clinical experience convinced him of the solid bases of psychoanalytic theories and he consistently defended psychoanalysis while hoping to "Frenchify" it. Along with the Sainte-Anne group of psychiatrists and the Minkowskis, good friends of his, he was one of the founding members of *L'Évolution psychiatrique* (Psychiatric Evolution) and its review in 1925, as well as of the Société psychanalytique de Paris in 1926 (of which he was several times president), and the *Revue française de Psychanalyse* (French Review of Psychoanalysis), going on to become its first general secretary (1927 to 1929).

In 1927 he married Hélène Janet, Pierre Janet's daughter. He tried in vain to organize an encounter between Freud and his father-in-law.

A highly talented man, a brilliant polemicist, a fervent Catholic, a supporter of the death penalty and medical and "national" psychoanalysis, he applied in 1927 to become a member of the Ligue de l'Action Française (a right-wing anti-Semitic organization). He believed that Catholicism was a factor in maintaining social order, in opposition to the Jewish or Protestant spirit. Seeing that "the Pope is becoming a Protestant," he approached Charles Maurras, the leader of Action Française, to join.

Some hundred or so articles bear witness to his medical and psychoanalytic activity in the field of childhood, psychosis and, of course, linguistics, which remained the strong point in all his thinking. In his article dated 1928, "Position du problème de l'adaptation réciproque entre la société et les psychismes exceptionnels" [Positioning the problem of reciprocal adaptation between society and exceptional psychisms], he abandoned the strict organicist definition of mental illness in favor of the theory of degeneration in terms of a failure to adapt, and delinquency. He crossed swords with Marie Bonaparte, whom he accused of denying the responsibility of the individual. Opposed to the man he ceremoniously referred to as "Monsieur Freud," and Princess Marie Bonaparte, he fought against "Laienanalyse" (lay analysis) and tried to use language to combat the internationalism of psychoanalysis. In 1927 he proposed to translate "libido" with the word "aimance" and the Es (id) with "infra-moi" (infra-self).

In three conferences dating from 1937, entitled "À l'aise dans la civilisation" [Civilization and the contented], in response to Freud's *Civilization and Its Discontents*, he defended, not without humor, the values of the manly man and the womanly woman, fought against feminism, and theorized on "How thought takes flesh." Praising the merits of Descartes, Roland Dalbiez, and Madame Borel-Maissonny, a specialist on language disorders, he criticized the arbitrariness of the sign in Ferdinand de Saussure, explaining the latter's error by the fact that he was anchored in the traditions of a country that lacked linguistic unity.

In two articles co-authored with Jacques Damourette and in his report to the International Psychoanalytic Association (IPA) in Paris in August 1938 entitled "La personne et la personnalité vues à la lumière de la pensée idiomatique française" [The person and the personality viewed in the light of idiomatic French thought], he studied the different forms of negation.

The paper stressed the value of the notions of “scotomization”—a concept forged with Laforgue and criticized by Freud — and “foreclosure,” which was to become one of the bases of Lacan’s theory.

In 1938, when Lacan’s article on the family appeared in the *Encyclopédie française*, he responded in polemical tone in the *Revue française de Psychanalyse* with “La famille devant Lacan” [The family before Lacan]. Recognizing the intelligence of Lacan who had read Karl Marx, he criticized him for his Germanism and his use of jargon, but acknowledged the importance of the discovery of the “mirror stage.”

In his *Journal* for August 23, 1945, Laforgue wrote: “Pichon was schizophrenic like his mother and uncle before him, and I knew it. This explains why I always tried to mount a vigilant guard at the demarcation line between reality and madness. But at the end of the day Pichon was the only person I could bring my patients’ dreams to when I could not understand them and for whom they seemed to be familiar. With good reason.” And when the time came, Jacques Lacan did not fail to salute “the late Édouard Pichon who, both in the indications he gave concerning the birth of our discipline and those that guided him through the darkneses of people, demonstrated a power of divination that we can only explain in relation to his practice of semantics” (*Écrits*, p. 258).

JEAN-PIERRE BOURGERON

*See also:* Congrès des psychanalystes de langue française des pays romans; France; Linguistics and psychoanalysis; Psychoanalysis and pediatrics; Psychopathology of Failure; *Revue française de Psychanalyse*; Scotomization; Société psychanalytique de Paris et Institut de psychanalyse de Paris.

### **Bibliography**

- Moreau, Daniel. (1980). Édouard Pichon, médecin, psychanalyste, linguiste: vie et oeuvre: contribution à l’histoire du mouvement psychanalytique français. S.l., s.n.
- Pichon, Édouard. (1928) Position du problème de l’adaptation réciproque entre la société et les psychismes exceptionnels. *Revue Française de Psychanalyse*, 2, 1, 135–170.
- . (1938) La personne et la personnalité vues à la lumière de la pensée idiomatique française. *Revue Française de Psychanalyse*, 10, 3, 447–461.
- . (1939) La famille devant Lacan. *Revue Française de Psychanalyse*, 11, 1, 107–135.

## **PICHON-RIVIÈRE, ENRIQUE (1907–1977)**

Enrique Pichon-Rivière, the Argentinean physician, psychiatrist, and psychoanalyst, was born in Geneva on June 25, 1907, and died in Buenos Aires on July 16, 1977.

He was three years old when his parents, originally from France, arrived in Argentina. The family settled in the heart of the Chaco forest and spent four years in this inhospitable region, under the obsessive threat of a fierce attack from the Guarani Indians who, apart from their group incursions, were otherwise hard-working and peaceful. This coexistence afforded the young Enrique an opportunity to familiarize himself with Guarani culture and to learn their language. When he was eight years old, his family left the region to move to the province of Corrientes, before settling in the city of Goya where he studied in the school founded by his mother. Sports, poetry, and painting were the great passions of his childhood, adolescence, and early adulthood. Pichon-Rivière readily admitted that his readings of Lautréamont, Rimbaud, and Artaud exercised a constant influence on his thought. In 1946 he published “Lo siniestro en la vida en la obra del conde de Lautréamont [The Sinister in the Life and Work of the Count de Lautréamont].

In Buenos Aires he studied medicine, worked as a journalist, and played an active part in the intellectual Bohemia of his day. He finally qualified as a physician in 1936.

He married Arminda Aberastury, who went on to become an eminent child psychoanalyst. As a result of his success in a competitive examination he was appointed psychiatrist at the Hospicio de las Mercedes. There he experienced something that was to have a decisive influence on his training: the creation of “operational groups.” Pichon-Rivière could be described as one of the greatest pioneers of modern psychiatry in Argentina.

Although he had read Freud since his youth and was driven by an intense intellectual curiosity, it was not until the end of the 1930s that he entered into contact with Celes Cárcamo, Angel Garma, and Arnaldo Rasovsky, with whom he founded the Asociación Psicoanalítica Argentina in 1942. He occupied an important position within this institution as the direct or indirect master for several generations of psychoanalysts.

Pichon-Rivière did not leave an abundance of writings behind him. He was more gifted at transmitting

his knowledge orally, his teachings being collected and elaborated by his disciples in what could be considered the most creative and the best defined contributions of Argentinean psychoanalysis. Among his most prominent disciples we find José Bleger and David Liberman.

One of the central notions in his work is the constitution of *Esquema Conceptual Referencial y Operativo* (ECRO; Referential and Operational Theoretical Schema) as an instrument for apprehending reality in a scientific manner. In a rising theoretical-practical spiral (praxis) he took a researcher's view of life experience and learning, as well as popular sources of knowledge.

In the scientific milieu his intellectual independence and his indomitable spirit of innovation caused conflict in his relations with institutions and people. His links with the Psychoanalytic Association were punctuated with difficulties and his family life was not renowned for its stability. In 1956 he divorced Arminda Aberastury. His second wife died in a road accident and he finished his days with the woman who helped him to organize and maintain what he claimed was the institutional foundation for his thinking: the School of Social Psychology.

His thinking and scientific development were characterized by his efforts to redefine psychoanalysis as a social psychology. It is no accident that the work that contains the greater part of his writing is entitled *Del psicoanálisis a la Psicología social* (1970, From Psychoanalysis to Social Psychology). In this volume we find work by Pichon-Rivière from the 1940–1969 period, work that clearly reflects the variety of interests and obsessions that focused his attention in different studies. Among those that stand out for their originality are the creation of “operational groups” and the notions of “mouthpiece” (*portavoz*) and “emergent” (*emergente*) that derive from this. For the author, the individual is emerging and therefore a mouthpiece for his or her family group, which is in turn the mouthpiece of the socio-cultural group of which it is a part. Hence his conception of the psychism as an “internal group” in interaction with and interdependent with external groups.

In the domain of psychopathology Pichon-Rivière posited that health and illness are not static categories but correspond rather to modes of reading and adapting to reality. “Active adaptation to reality” supposes a

transformational and a critical reading of it, a reading that in turn produces a transformation of internal structures. His theory of the “single illness” posits the existence of a central psychotic nucleus—a basic depressive situation—that is pathogenic, all pathological structures being attempts at an elaboration of or detachment from this nuclear situation. Among the factors that intervene in the configuration that structures adopt, we can list: polycasuality, phenomenal plurality (body, exterior world, and mind) and genetic and functional continuity.

SAMUEL ARBISER

*See also:* Argentina; Group psychotherapy; Inter-generational.

### Bibliography

- Arbiser, Samuel. (1978). Un modelo de psicoterapia grupal. Los aportes de Pichon-Rivière. *Revista de Psicoanálisis de la Asociación Psicoanalítica Argentina*, 35, 4, 821–839.
- . (1985). El grupo interno. Reflexiones acerca de la relación entre la red intrapsíquica e interpersonal psicoanálisis. *Asociación Psicoanalítica de Buenos Aires*, 7, 3, 389–415.
- Avenburg, Ricardo. (1996). Enrique Pichon-Rivière, sus enseñanzas a la luz de mi vínculo con Al. *Actualidad Psicológica*, 21, 231, 12–14.
- Pichon-Rivière, Enrique. (1970). *Del psicoanálisis a la psicología social*. Buenos Aires: Galerna.
- . (1980). *Teoría del vínculo*. Buenos Aires: Nueva Visión.

---

## PICTOGRAM

The term *pictogram* was used by Piera Aulagnier to describe the primal form of representation that is shared by all subjects but retains a special force of attraction for psychotics. According to Aulagnier, a pictogram represents not an object but the uncompleted experience of an encounter between a sensory zone and an object capable of completing it. The term thus has no relation to the way in which Freud used it in *The Interpretation of Dreams* (1900a) in connection to writing with images (*Bilderschrift*) in the dream-work. A pictogram is a representation of an instantaneous action (introjecting/rejecting) whose principle



feature, in this stage when the psyche is still unaware of anything outside itself, is the specular relation that comprises it.

Aulagnier's theory of the primal may be held alongside what Freud wrote in "Negation" (1925h) about the workings of the activity of the judgment that attributes existence based on an evaluation of whether an object is good or bad: "Expressed in the language of the oldest—the oral—instinctual impulses, the judgment is: 'I should like to eat this,' or 'I should like to spit it out'; and, put more generally, 'I should like to take this into myself and to keep that out.' That is to say: 'It shall be inside me' or 'it shall be outside me'. As I have shown elsewhere, the original pleasure-ego wants to introject into itself everything that is good and to eject from itself everything that is bad." (p. 237) In Aulagnier's view, introjection and rejection entail consequences for the psychical agency involved. In *The Violence of Interpretation: From Pictogram to Statement* (1975/2001), she writes, "seen, heard, tasted will be either well perceived by the psyche as a source of pleasure of its own production, and therefore especially forming part of what is 'taken' inside itself, or as a source of pain to be rejected and this rejection *implies* that the psyche cuts off from itself what, in its own representation, brings into play the organ and the zone, the source and seat of excitation" (p. 22). The postulate of a self-procreation specific to the primal is logically deducible from the fact that at this stage the object, whether it is to be put inside or outside of the self, is not external to the self in question, which is nothing more than a collection of sensations.

Having thus defined the pictogram on the basis of the dichotomy between introjecting and rejecting, Aulagnier took yet another step toward structural definition, no longer of the represented, but of the representative—of the psyche itself—as she had done for the primary and secondary processes. At issue here was the definition of psychical agencies other than those posited by Freud but that do not replace the latter and, above all, whose origin is different because each case involves the reflection (in the literal sense) of mental activity onto itself. The influence of Jacques Lacan's mirror stage (1966/2004) is felt here, but Aulagnier retained from that model only the movement of specularization, which she viewed as a constant of mental activity from its very beginnings. In *The Violence of Interpretation* she wrote that "any creation of the psychical activity is presented to the psyche

as a reflection, a presentation to itself" (p. 24). This process becomes difficult to grasp, however, when the dichotomy between reflecting agent and reflected object does not yet exist; but whereas other authors had spoken of indissociability or fusion in these instances, Aulagnier adhered to the notion of the specular image. In the same book she wrote: "If one accepts that in this phase the world—the outside-the-psyche—has no existence other than in the pictographic representation that the primal makes of it, it follows that the psyche encounters the world as a fragment of specular surface, in which it mirrors its own reflection" (p. 24).

One might think that Aulagnier was begging the question when she asked us to consider a self (that is, a representing agency that is not yet either the Freudian ego nor what Aulagnier called the I) that can only know of the outside that which is given as a reflection of the self in question, and that can only know itself as that which has engendered the fragment that itself reflects it. The whole question, so thorny in Freud's work, of the outcome of primary narcissism is found again here, but here, too, it is appropriate not to conceptualize in realist terms what is presented as a theoretical fiction. What ensures that there is a way out of this play of mirrors is simply, as in Freud, the difference that exists between a representation of the object and the real object able to satisfy a need. The mind must thus face the obligation—and this from the beginning, even if the description of these mechanisms leads to evoking them in succession—to acknowledge that the breast is an object different from the mind's body itself, that it has an independence and is thus not self-generated.

What are the effects of desire and non-desire at the level of the primal representation constituted by the pictogram? To the extent the psyche engages in making representations, they point to the fact that it itself has produced the hated object and even—owing to the specular relation—that it at least partially identifies with the latter. "In this case," wrote Aulagnier in *The Violence of Interpretation*, "the agency that sees itself in the represented contemplates itself as a source of its own pain; it then tries to annul and destroy that image of itself" (pp. 19–20).

What Melanie Klein theorized as splitting between a "good breast" and a hated "bad breast" has been conceptualized in various ways. Freud for one asserted that the bad comes before the good to the extent that the obligation to desire disturbs an anterior mythical

state of quiescence that is actually prior to life itself. Aulagnier did not adopt this perspective, in the sense that she saw love and hate of the object as appearing simultaneously. Freud, however, viewed hate as the initial repudiation of the external world by the narcissistic ego; in “Instincts and Their Vicissitudes” (1915c), he wrote: “Hate, as a relation to objects, is older than love. It derives from the narcissistic ego’s primordial repudiation of the external world with its outpouring of stimuli” (p. 139).

To the extent that, according to Aulagnier, primary narcissism is not a closed unity but rather the reflection that the representative perceives of itself in its self-generated representations, there is always either simultaneously, depending on whether we side with Eros or Thanatos, the image of an encounter involving pleasure, or that of a delay or a lack that occasions unpleasure. Thus, in Aulagnier’s view, getting rid of the bad by rejecting it will require, since the bad is indissociably linked to a bad sensory zone that has engendered it, the destruction of the latter. “The wish to destroy the object,” she wrote in *The Violence of Interpretation*, “will always be accompanied, in the primal, by the wish to annihilate an erogeneous, sensory zone, as well as the activity of which that zone is the seat” (pp. 27–28). According to Freud, rejection allows a “purified pleasure-ego” to remain. In this instance it cuts off a part of the representative’s self, a process viewed by Aulagnier as the “archaic prototype of castration” (p. 28) that will be reshaped into a fantasm at a later stage. Where she is in agreement with Freud, on the other hand, is in the preeminence of Thanatos over Eros, since the latter can only win out by desiring an object that, by means of the satisfaction it brings, leads, at least momentarily, to a state of nondesire, of quiescence.

The analysis of the pictogram Aulagnier proposes amounts to developing, affirming, and complicating the notion of the drive and its representative. But where Freud spoke of excitation, need, or instinct, Aulagnier preserved the notion of a “body” that she described as being simultaneously—the provider of representational-models for the psyche, the irreducible proof of the existence of a “somewhere else,” the privileged object of a desire for destruction and, lastly, the source and locus of an erotogenic pleasure.

The originality and the fruitfulness of the notion of the pictogram derive from the fact that its structure is based on specularity. This notion also allows an approach to psychosis based on the fact that, for the

future psychotic, the experience of conjunction is most often one of violence and intrusion, and not one of a complementarity that occasions pleasure. This could be compared to the idea Winnicott furthered in “Psychosis and Child Care” (1952), of the need for “good enough” environment—that is, one that for a time preserves the illusion of omnipotence and thus an image of self-procreation formed under the influence of pleasure and Eros. As Aulagnier wrote in *The Violence of Interpretation*, a specific feature of psychosis is “to make possible the re-presentation between the primal space and the space outside-the-self of a state of specularisation” (p. 31).

SOPHIE DE MIJOLLA-MELLOR

*See also:* *Apprenti-historien et le maître-sorcier (L’-)* [The apprentice historian and the master sorcerer]; Breastfeeding; Criminology and psychoanalysis; Idea/representation; Ideational representation; *Infans*; Logic(s); Primal, the; *Violence of Interpretation, The: From Pictogram to Statement*; Visual.

### Bibliography

- Aulagnier, Piera. (2001). *The violence of interpretation: From pictogram to statement*. (Alan Sheridan, Trans.). Hove, U.K., and Philadelphia: Brunner/Routledge. (Original work published 1975)
- . (1979). *Les destins du plaisir. Aliénation, amour, passion*. Paris: Presses Universitaires de France.
- . (1984). *L’apprenti-historien et le maître-sorcier. Du discours identifiant au discours délirant*. Paris: Presses Universitaires de France.
- Freud, Sigmund. (1900a). The interpretation of dreams. Part I., *SE*, 4: 1–338; The interpretation of dreams. Part II., *SE*, 5: 339–625.
- . (1915c). Instincts and their vicissitudes. *SE*, 14: 109–140.
- . (1925h). Negation. *SE*, 19: 233–239.
- Lacan, Jacques. (2004). The mirror stage as formative of the function of the I as revealed in psychoanalytic experience. *Écrits: A selection* (Bruce Fink, Trans.) (pp.3–9). New York: W. W. Norton. (Original work published 1966)
- Mijolla-Mellor, Sophie de. (1998). *Penser la psychose. Une lecture de Piera Aulagnier*. Paris: Dunod.
- Winnicott, Donald W. (1958). Psychosis and child care. In his *Collected papers: Through paediatrics to psycho-analysis* (pp. 219–228). London: Tavistock Publications. (Original work published 1952)

## PLEASURE EGO/REALITY EGO

In his work on instincts, Freud introduced a distinction between those whose sole aim is the search for pleasure and the avoidance of unpleasure and those that tend to adapt to the realities of life, which cannot be done without renouncing pleasure to some degree. This discrepancy results in conflicts within the ego that are sometimes resolved by splitting.

The pleasure ego may adapt to the reality ego by postponing a yield of pleasure. This is the normal and the most usual course of things. It depends, however, on the ego's having reached a certain level of development.

During early childhood, the reality ego is still weak, while the pleasure ego has only two functions, namely to satisfy the oral zone and to cause the body-ego to be experienced as pleasurable. After breastfeeding comes sleep, after sleep breastfeeding once again—and the reaction to any disagreeable feeling is to cry. As soon as the anal stage is reached, conflicts arise between the reality ego and the pleasure ego. The pleasure ego demands only the evacuation of the bowels, which is accompanied by great pleasure. The reality ego for its part requires that this occur only at a particular time and place. Once this has been achieved, it further demands that pleasurable sensations in the anal zone be reduced to a minimum. This last requirement is probably not satisfied in all individuals, giving rise to the kinds of behavior that we call perversions.

So long as the sexual instinct stays in its infantile mode, it is relatively easy for the reality ego to fulfill its function of adaptation to reality. Which having been said, it is quite possible for the two egos to clash even during early childhood, for the reality ego maneuvers by contriving all kinds of displacements, so causing a set of symptoms to arise as a way of gratifying the pleasure ego. Many childhood illnesses attest to this, since they are often the consequence of a surrender by the reality ego. Such situations may even lead to serious psychosomatic illness. Generally, however, a strong reality ego and a developing superego or ideal ego will help the subject overcome the difficulties of this period and embark on a relatively conflict-free latency.

With the onset of puberty, the pleasure ego lays siege to the reality ego with extraordinary vigor. During this time, which may extend over several years, it easily happens that the pleasure ego gains the ascen-

dancy. As a rule, the consequence of the conflict between the reality ego and the pleasure ego is bizarre behavior, veering back and forth between the exalted to the depressive and punctuated by violent bouts of ill temper. Everything depends in this period on the strength of the superego; if the superego is absent or very weak, its role is perforce assumed by social organizations—by gangs or other kinds of groups. The kind of group chosen by the ego in puberty will depend on social opportunity. The social conditions under which the adolescent grows up are therefore of the greatest importance in determining behavior. A good social environment means that desires can more often be met in a social way, and it leaves far more room for the expression of the abilities (athletic, intellectual, artistic, and the like) that might strengthen young people who are striving as best they can to get through puberty. In any event, the primary goal during this period is to supply the reality ego with the resources to defeat the pleasure ego.

Should such favorable conditions be lacking, the pleasure ego is liable to realize its aspirations by errant means, as witness drug abuse, for example. In most cases, however, the reality ego carries the day and succeeds in imposing its dominance—in principle, as soon as adolescence comes to an end. The pleasure ego is left a certain amount of space, depending on the exigencies of social adaptation. The amount of satisfaction that the reality ego can grant the pleasure ego is largely a function of social and cultural circumstances. The capacity to sublimate has a significant role here. Thanks to sublimation, the reality ego, aided by the superego, manages to persuade the pleasure ego to expect a measure of gratification on a higher mental plane. In other words, the pleasure ego can experience a great deal of pleasure once the individual has reached a high social level and is able to tolerate long delays before reaching this goal. This represents an ideal form of cohabitation between the reality ego and the pleasure ego, one which, under auspicious social conditions, may begin to develop as early as childhood.

ERNST FEDERN

*See also:* Binding/unbinding of the instincts; Children's play; Choice of neurosis; Conflict; Dependence; Desexualization; Disavowal; Dualism; Ego; Historical reality; Humor; Hypercathexis; Internal/external reality; Mater-

nal; “Negation”; Pleasure/unpleasure principle; Primary process/secondary process; Principle of constancy; Psychic reality; Purified-pleasure-ego; Reality principle; *Totem and Taboo*; Work (as a psychoanalytical notion).

### **Bibliography**

Freud, Sigmund. (1911b). Formulations on the two principles of mental functioning. *SE*, 12: 213–226.

———. (1915c). Instincts and their vicissitudes. *SE* 14: 109–140.

———. (1925h). Negation. *SE* 19: 233–239.

### **Further Reading**

Loewald, Hans (1951). Ego and reality. *International Journal of Psychoanalysis*, 32, 10–18.

---

## **PLEASURE IN THINKING**

According to Sigmund Freud, “thought-processes are in themselves without quality, except for the pleasurable and unpleasurable excitation which accompany them, and which, in view of their possible disturbing effects upon thinking, must be kept within bounds,” (*The Interpretation of Dreams* [1900a], p. 656). However, the notion of sublimation allows us to consider the activity of thought and the partial processes that compose it as a libidinal investment, and as an offshoot of narcissism that offers a pleasure as limitless as knowledge itself.

For Sándor Ferenczi, in “The Birth of Intellect,” suffering is at the origin of intellect, which “is born not simply of common, but only of traumatic, suffering. It develops as a consequence of, or as an attempt at, compensation for complete mental paralysis. . . . *Pure intelligence* is thus a product of dying, or at least of becoming mentally insensitive, and is therefore *in principle madness, the symptoms of which can be made use of for practical purposes.*” (“Notes and Fragments,” [1931], p. 244–46).

This perspective on the relation between trauma and the development of intelligence was taken up again by numerous authors, for example by Kurt R. Eissler (1961), and Didier Anzieu and Matthew Besdine (1974). Nevertheless, the issue of decathexis or inhibition of thought would not arise if we did not assume that the subject had already developed a capacity to master trauma through thought and to feel

pleasure at this prospect. Rather than suffering in itself, it is confidence in the capacity to master suffering that can create cathexis in intellect. This evokes a fantasy of certitude, of a truth that is just on the horizon, aiming at an ultimate synthesis, like the absolute knowledge of Hegel, the third kind of knowledge of Spinoza, or the contemplation of the world of ideas of Plato.

The pleasure of thinking appears, however, not only as a goal, but also as the surplus pleasure produced by whatever the exercise of intellect puts into play through the sublimation of the partial drives of seeing and seizing. These two drives combine, as Nietzsche described the character of the scholar, to form “an ego with an unlimited avidity, which desires everything and would want to see with the eyes and take with the hands of a thousand people, an ego that recovers all the past and would lose nothing that could belong to it” (in Mijolla-Mellor, Sophie de, 1992).

Considered from the standpoint of intellectual development, pleasure and trauma might be equally necessary. The initial methodology of thought is to ignore perplexity and doubt, regarding what it discovers as unquestionably true; afterwards there comes a time when the basis of evidence collapses—whether this is regarded as a result of the primal scene, as for the Wolf Man, or a discovery; in whatever form it takes, whatever the child regarded as secure is fond to be an illusion. The pleasure that thought aims at experiencing consists in the attempt to recreate a basis for certainty that it will not fail again (Mijolla-Mellor). Pleasure in thinking will consist, from then on, in the encounter with points of certitude, effected through a construction of thought. The subject learns that these points of certitude are not fixed forever and that it is in their power to reconstitute them under other forms, if necessary. This experience of the pleasure of reconstructing points of certitude, which are capable of substituting for the kind of evidence available to sensation, is a condition for being able to cathex to thought, and should be distinguished from an exercise in obsessional intellectualizing defense. On the contrary, the visionary intuition of the researcher provides them with instants when thought not only operates through images to be captured in sensible form in the imagination, but itself turns into an image or schema fusing the primary and secondary processes. The desire for knowledge, in so far as it always pursues an object just out of reach, an enigma present in the

appearance of things, would be opposed to any renunciation of dissatisfaction. The desire for knowledge works against the force of Thanatos by keeping the will to question alive.

SOPHIE DE MIJOLLA-MELLOR

*See also:* Civilization (*Kultur*); Intellectualization; Jokes; Reciprocal paths of influence (libidinal coexcitation).

### **Bibliography**

- Eissler, Kurt R. (1961). *Leonardo de Vinci*. New York: International Universities Press.
- Ferenczi, Sándor. (1933 [1955]). *Notes and fragments. Final contributions to the problems and methods of psycho-analysis*. (Eric Mosbacher and others, Trans.) New York: Basic Books.
- Freud, Sigmund. (1900a). The interpretation of dreams. *SE* 4, 5.
- Mijolla-Mellor, Sophie de. (1992). *Le plaisir de pensée* [The pleasure of thought]. Paris: Presses Universitaires de France.

---

## **PLEASURE / UNPLEASURE PRINCIPLE**

The pleasure/unpleasure principle, often shortened to *pleasure principle*, requires the psychic apparatus to automatically discharge excitations when they accumulate above a certain threshold and are experienced as unpleasure. This principle governs the functioning of the primary processes and is the basis for the economic viewpoint in metapsychology.

The translation of the German *Lustprinzip* by “pleasure principle” in English warrants some comment. The German *Lust* actually has two meanings: that of pleasure, but also that of desire or want. *Lust haben auf* is the most common expression for “to want, to have a desire for.” The pleasure principle is thus also the “desire principle”: The psychic apparatus can do nothing else but desire, says Freud. Similarly, with regard to the rendering of *Unlustprinzip* as “unpleasure principle” in *The Interpretation of Dreams* (1900a), it should be kept in mind that *Unlust* in German also means “aversion.” Consciousness turns away from that which occasions aversion.

Although philosophers throughout the ages, notably Epicurus, have opposed pleasure and pain, or linked pleasure to the absence of pain, the concept of

the pleasure principle originated in John Stuart Mill’s *Utilitarianism* (1861), where pleasure and the avoidance of pain are posited as the two ends of life, and in the natural philosophy of Gustav Fechner, who in 1848 published an essay entitled *Über das Lustprinzip des Handelns*. Sigmund Freud is also known to have translated Mill’s essay on George Grote’s *Plato* (1866).

However, it was during their theoretical elaboration of the first analytic treatments in *Studies on Hysteria* (1895d) that Freud and Josef Breuer first discovered the role of pleasure and unpleasure as mental qualities that determine repression, and that they formulated the principle of constancy, which was inspired by the concept of homeostasis in physiology.

In Chapter VII of *The Interpretation of Dreams*, Freud estimates pleasure and unpleasure to be the only psychical qualities actually apprehended by consciousness, other than external excitations received by the perceptual system. The excitations of pleasurable and unpleasure are thus seen as almost the only elements that make it possible to describe a transformation of energy inside the psychic apparatus. It is “the releases of pleasure and unpleasure [that] automatically regulate the course of cathetic processes” (1900a, p. 574), which Freud calls the “unpleasure principle.”

Freud inaugurates his fictional depiction of the primitive psychic apparatus with the notion that the accumulation of excitation is experienced as a tension that elicits unpleasure, and that it activates the psychic apparatus in order to repeat the experience of satisfaction, which on previous occasions brought about a reduction in tension that was experienced as pleasure. Desire is thus defined as the current within the psychic apparatus that goes from unpleasure to pleasure; it alone sets the psychic apparatus in motion. The obtaining of pleasure is primitively sought in a hallucinatory mode in which perception becomes identical to the traces recorded in a primitive experience of pleasure: This is the mode of operation of the primary psychic processes. Moreover, the unpleasure principle prohibits the psychic apparatus from introducing painful elements during the course of its thoughts, and all mental acts liable to provoke a signal of unpleasure will be repressed.

However beginning with the “Three Essays on the Theory of Sexuality” (1905), Freud observes the need to differentiate between kinds of tension more clearly, and perhaps to not always associate tension with

unpleasure; since the tension involved in the state of sexual excitation cannot be ranked among the feelings of unpleasure. Pleasure and sexual tension are thus only indirectly related. He then delineates a preliminary pleasure, which he employs as the preliminary pleasure principle in *Jokes and Their Relation to the Unconscious* (1905c).

In “Formulations of the Two Principles of Mental Functioning” (1911b), the unpleasure principle is called the *pleasure/unpleasure principle* and then shortened to *pleasure principle*. It characterizes the functioning of the pleasure-ego, but undergoes a modification over the course of the development of the psychic apparatus: The reality principle imposes a detour upon the pleasure principle; it defers satisfaction, or eliminates certain possibilities for satisfaction, by subordinating it to a test as to whether conditions that are favorable to it exist in reality. But the reality principle also guarantees survival, since total submission to the pleasure principle would likely lead to death, even though the young infant, “provided one includes with it the care it receives from its mother” (pp. 219–220, n. 4) comes close to producing a psychical system of this kind; as Freud remarks in a footnote where Donald Winnicott would later locate the mother-infant unit upon which he based his theory of human development.

In *Beyond the Pleasure Principle* (1920g), Freud calls into question some of his own earlier theoretical conceptions when he discusses repetition compulsion. Clinically documented in dreams, traumatic neuroses, children’s games, and transference neurosis, the repetition compulsion is placed above the pleasure principle. Later, in “The Economic Problem of Masochism” (1924c), he dissociates the states of pleasure and unpleasure from the economic factors of relaxation and tension. Pleasure and unpleasure do not seem to depend upon this quantitative factor but instead on a qualitative aspect, some of whose traits Freud suggests: rhythm, the temporal flow of modifications, and rises and falls in the quantity of excitation. Although he reconfirms the tendency of the psychic apparatus to rid itself of tensions or reduce them to a minimum, he now calls this tendency, following Barbara Low, the “Nirvana Principle,” which consists in reducing to zero the general level of excitation of the psychic apparatus. What is involved thereafter is a tendency of the death drive; whereas the pleasure principle stems from the libido. As for the reality principle, its role is to

imposes a modification of the pleasure principle, which thereby takes into account the influence of the outside world.

MICHÈLE POLLAK CORNILLOT

*See also:* Principles of mental functioning.

### **Bibliography**

- Fechner, G. T. (1848). Über das Lustprinzip des Handelns. *Zeitschrift für Philosophie und philosophische Kritik-Neue Folge*, 19. 1–30, 163–194.
- Freud, Sigmund. (1900a). *The interpretation of dreams*. *SE*, 4–5: 1–625.
- . (1905c). Three essays on the theory of sexuality. *SE*, 7: 130–243.
- . (1911b). Formulations on the two principles of mental functioning. *SE*, 12: 218–226.
- . (1920g). Beyond the pleasure principle. *SE*, 18: 7–64.
- . (1924c). The economic problem of masochism. *SE*, 19: 155–170.
- Mill, John Stuart. (2001). *Utilitarianism*. (George Schel, Ed.). Indianapolis, IN: Hackett Publications.

### **Further Reading**

- Glick, Robert, and Bone, Stanley, eds. (1990). *Pleasure beyond the pleasure principle. The role of affect in motivation, development, and adaptation* (Vol. 1). New Haven/London: Yale University Press.

---

## **POLAND**

Poland was divided between Germany, Russia, and Austria-Hungary when psychoanalysis came into being at the beginning of the twentieth century. Ludwig Jekels, a follower of Freud, practiced psychoanalysis in Austrian Poland in the clinic he directed outside Lvov, a city that has been Ukrainian since 1945 but was Austro-Hungarian at the start of the twentieth century. Jekels was joined by Hermann Nunberg until the latter emigrated to the United States. We also have to thank him for the first publications in Polish dating from 1908. Between 1911 and 1914, three titles appeared in the Polish Psychoanalytic Library.

After World War I psychoanalysis went through a dynamic period of development in the new Polish

state. As a result of its many publications and conferences, its influence extended to the medical world and the cultural life of the country. The majority of Polish analysts at the time were trained in the Berlin Institute. Two names stand out: Roman Markuszewicz and Gustav Bychowski. The first published an apologetic work in 1926 on psychoanalysis and its therapeutic function and, ten years later, a critical work: "Toward a Revision of the Fundamental Freudian Notion." Bychowski was trained in Berlin and published on metaphysics and schizophrenia there before returning to Poland to take up a position in Warsaw as a university professor. There he published on the psychoanalytic aspect of the psychoses. The following names are also worthy of note: Stefan Borowiecki, Maurycy Bornsztajn, Jan Kuchta, Rudolf Kesselring, Wladislaw Matecki, Joseph Mirski, Norbert Praeger, Adam Wisel, and Leopold Wolowicz.

Eugénie Sokolnicka deserves a special mention. She trained in Zurich, Vienna, and Budapest between 1911 and 1920 but, not being a physician, she failed to find her place in the Warsaw psychoanalytic milieu of 1920. Freud, who had been her analyst, advised her to go to Paris, where she arrived in 1921. She met with no better success in the Paris medical world, but she analyzed René Laforgue and Édouard Pichon. She did, however, take an active part in founding the Paris Psychoanalytic Society in 1926 and became its first vice-president.

World War II and the ensuing communist régime reduced this first development to dust and it took another ten years before the Polish psychoanalytic movement again showed signs of life. Three young psychiatrists went to train in Hungary and Czechoslovakia, where psychoanalysis was leading an underground existence. The first of these, Jan Malewski, went first to Prague and then, more importantly, to Budapest, where for ten years he alternated six months of analysis with Imre Hermann and six months of activity in Poland. The second, Zbigniew Sokolik, had Theodor Dosuzkov as his analyst in Prague. The third, Michael Lapinski, was analyzed in Prague by Otakar Kucera.

Greater freedom of circulation between eastern countries and later between them and the West fostered a new period of development for psychoanalysis: Young psychiatrists and psychologists in analysis went on to become the active practitioners of contemporary Polish psychoanalysis. In this climate the International Psychoanalytic Association (IPA) elected two direct

associate members at the 1989 Congress in Rome: Elzbieta Bohomolec, a psychiatrist who was analyzed by Michael Lapinski in Warsaw and who was in supervision in Berlin; and Katarzyna Walewska, a psychologist in analysis in Warsaw and then in Paris, and who was in supervision in Warsaw and London. They are at the root of two psychoanalytic groups. The first, the Polish Society for the Development of Psychoanalysis, was founded in 1991; the second, the Institute of Psychoanalysis and Psychotherapy, was founded in 1992. The names of these two groups clearly reflect the nuance that distinguishes them: increasing the number of practitioners for the first, the quality of the training for the second. Members from both groups work together in the Rąstów Center for Psychotherapy of Neuroses, founded in 1965 by Jan Malewski. Having been prohibited during and after World War II, psychoanalysis began to be taught in the psychology faculties of Warsaw, Krakow, and Lublin in 1961. Psychotherapeutic practice has developed in these cities and in Gdansk.

Only Zbigniew Sokolik has remained in Warsaw. Michael Lapinski emigrated to Australia in 1983 and became a member of the Australian Psychoanalytic Society. Jan Malewski settled in Heidelberg in 1975 and became a member of the German Psychoanalytic Association. At the same time émigrés who fled the Nazi persecutions, like Hanna Segal, have reestablished contacts with Poland. Analysts from the international analytic community have visited Poland to give clinical and theoretical training in psychoanalysis. The vitality of the Polish group was demonstrated in 1991 at Pototsk, near Warsaw, on the occasion of the third seminar for East Europeans, a seminar that was organized under the auspices of the European Federation of Psychoanalysis.

MICHEL VINCENT

### **Bibliography**

- Bychowski, Gustav. (1952). *Psychotherapy of psychosis*. New York, London: Grune and Stratton.
- . (1954) On the handling of some schizophrenic defence mechanisms and reaction patterns. *International Journal of Psycho-Analysis*, 35, 2, 147–153.
- . (1966). Obsessive compulsive façade in schizophrenia. With commentary by M. Wexler. *International Journal of Psycho-Analysis*, 47, 2–3, 189–202.

Diatkine, Gilbert, et al. (1993). La psychanalyse en Europe orientale, in Diatkine, Gilbert; Le Goues, Gerard; and Reiss-Schimmel, Ilana (Eds.), *La psychanalyse et l'Europe de 1993*. Paris: Presses Universitaires de France.

## POLITICS AND PSYCHOANALYSIS

Within the wide range of cultural and social interests that led to Sigmund Freud's "The Claims of Psychoanalysis to Scientific Interest" (1913j), politics appears as the poor relative. However, contrary to the rumor that claims Freud was "apolitical," or "politically inert," it can be shown that there are extremely close links between all of Freud's work—analyses, investigations, concepts, projects—and the sources and resources that constitute truly political thought. Together with the American ambassador William C. Bullitt, Freud put his name to a book of political psychoanalysis in the strict sense, *Thomas Woodrow Wilson, Twenty-Eighth President of the United States: A Psychological Study*, (1966 [1938]), that has received little comment. Freud's anthropological work is considerable. He questioned the origin and structure of society in *Totem and Taboo* (1912–1913a), unmasked illusions and dogmas in *The Future of an Illusion* (1927c) and *Civilization and its Discontents* (1930a), denounced Bolshevism in one of the *New Introductory Lectures on Psychoanalysis*—"On a Weltanschauung" (1933a), and described the foundation of a religion, a culture, and a people—the Jews—in *Moses and Monotheism* (1939a). In 1908 he strongly criticized "civilized sexual morality" (1908d), the source of "the nervous illness of modern times." His 1921 essay, *Mass Psychology and the Analysis of the Ego* (1921c), which dismantles the concepts of leader, crowd, and power, can be seen as the foundation of all political psychoanalysis.

In *The Interpretation of Dreams* (1900a), politics saturates the imagery of the "dream of Count Thun," the prime minister of the emperor. Quoting Beaumarchais, Zola, Panizza, and mobilizing the revolution of 1848, social-democracy, and anti-Semitism, Freud denounces the "nothingness" represented by Count "Nichtsthun" and celebrates his own "revolutionary humor." Although he is not committed to political action like his friend Heinrich Braun, at least he sees his foundational work, *The Interpretation of Dreams*, as a form of Promethean subversion: "Flectere si

nequeo Superos, Acheronta movebo"—"If I am unable to influence the Gods, I will shake up Hell." Aside from these lines of force of political thought, all Freud's psychological system is rich with political implications. Following Copernicus and Darwin, he lays claim to a true and grandiose ideological "revolution." In the unconscious the ego is no longer master in its own house and humanity must therefore drive it out. In the agency of the superego, Freud ascribed values, ideals, and imperatives associated with morality and society to the psyche.

No socio-political theory or practice can simply neglect the sovereign preeminence of drives and the unconscious, which various ideologies, especially totalitarian, have been able to exploit. The triptych of the sexual drive, the death drive, and the instinct for mastery exercises an implacable determinism throughout existence, social and political, individual and psychological. It is significant that the most heightened forms of political thought—Machiavelli, Hobbes, La Boétie, Marx, Weber, and others—intersect with and illustrate many of Freud's psychological ideas. The radical rejection of all forms of illusion, the will to lucidity based on a flexible rationality, the dismantling of connections within communities, the emphasis on the autonomy and responsibility of the individual subject—Freud's political thought remains an inexhaustible resource, even when contested or misused, for original psycho-political constructs. Some of these include the research and bold assumptions of Wilhelm Reich, often summarily categorized as "Freudian-Marxism," the "social-democratic" psychology of Alfred Adler, the anarchism of Otto Gross, the "Trotskyite" element in Otto Fenichel, the democratic and eclectic humanism of Erich Fromm, Herbert Marcuse's Orphic leftism, Deleuze and Guattari's libertarian schizoanalysis, and so on.

More recently the field of "psychohistory" has attempted to combine psychoanalysis and politics, but has managed instead to obscure and weaken what was so powerfully revolutionary in Freudian thought.

ROGER DADOUN

See also: Gross, Otto Hans Adolf; Group psychology; Illusion; International Psychoanalytic Association; Marxism and psychoanalysis; *New Introductory Lectures on Psychoanalysis*; *Thomas Woodrow Wilson, Twenty-Eighth President of the United States: A Psychological Study*.



### Bibliography

- Dadoun, Roger. (1987). *Psychanalyse et politique*. In P. Ory (Ed.), *Nouvelle histoire des idées politiques*. Paris: Hachette.
- . (1995). *La psychanalyse politique*. Paris: Presses Universitaires de France.
- De Marchi, Luigi. (1981). *Psycho-politique*. Paris: Payot.
- Money-Kyrle, Roger. (1946). *Psychoanalysis and politics, a contribution to the psychology of politics and morals*. London: G. Duckworth.
- Reich, Wilhelm. (1945). *Character-analysis: Principles and technique for psychoanalysts in practice and in training*. (Theodore P. Wolfe, Trans.) New York: Orgone Institute Press. (Original work published 1933)

## POLITZER, GEORGES (1903–1942)

Georges Politzer, a French philosopher, was born May 3, 1903, in Nagyvarad, Hungary, and died on May 23, 1942, in Mont-Valérien, France, where he was shot by a firing squad. Born into a Jewish family, Politzer's father, a doctor, is said to have participated in the 1919 communist regime in Budapest. Young Politzer was soon confronted by the upheavals that shook Central Europe following World War I. Forced to leave Hungary, he stayed briefly in Vienna, where he appears to have embraced the work of Sigmund Freud, then moved to Paris in 1921.

Politzer majored in philosophy at the Sorbonne, where he studied with Léon Brunschvicg, whose rationalism had a profound effect on his thinking in spite of his later repudiation of the man. He became a naturalized French citizen in 1924 and received his philosophy degree in 1926. In 1930 he became a professor as well as a political militant, apparently losing all interest in psychology.

His interest in psychoanalysis can be traced to 1924 and the publication, in the review *Philosophies*, of two articles, "Médecine ou philosophie?" and "Le mythe de l'antipsychanalyse" (in Politzer, 1969). Two themes emerged from these publications: Freud had revolutionized the science of man by inventing a method that could be used to grasp the individual in his singularity while avoiding the abstraction that characterized contemporary psychology. But when Freud tried to establish a theoretical foundation for his general intuitions, he fell into the grip of classical psychology with its emphasis on formalism, abstraction, and realism. This is discussed in Politzer's *Critique des fondements de la*

*psychologie* (1928), where Freud's thought is used as a weapon against conventional psychology and as a model for the construction of the object of the concrete psychology of the future — the drama, or the dramatic life to the extent that it is the subject of a story. Politzer makes use of Freud's texts in a way no French philosopher had until then, especially *The Interpretation of Dreams*. The first six chapters are described to be exemplary for concrete psychology; the last, however, is strongly criticized, especially the passage in which Freud discusses regression, where Politzer sees a resurgence of psychological realism in the materialist concept of the psychic apparatus. He also felt that the concept of the unconscious belonged more to nineteenth-century philosophy and traditional psychology, and was an obscure concept that negated the real inspiration of psychoanalysis. He outlined the conflict between Freud's method and his theories, a dichotomy later picked up by many other philosophers.

Politzer became a member of the Communist Party in 1929. That same year he published "La crise de la psychanalyse" in *La Revue de psychologie concrète* and "Un faux contre-révolutionnaire, le freudo-marxisme," which appeared in 1933 in *Commune*, and in 1939, on the occasion of Freud's death, "La fin de la psychanalyse" in *La Pensée* (republished in Politzer, 1969). These articles articulate the split between a committed Marxist and psychoanalysis, which he condemned for its supposed dogmatism.

Politzer's 1928 book has influenced a number of French philosophers, especially Sartre and Merleau-Ponty, through the author's critique of the unconscious and the importance he gives to meaning in understanding human behavior. In 1946 Jacques Lacan wrote a glowing encomium to Politzer's life and work.

ROGER BRUYERON

*See also:* France; Marxism and psychoanalysis; Philosophy and psychoanalysis; Psychic apparatus.

### Bibliography

- Politzer, Georges. (1994). *Critique of the foundations of psychology: the psychology of psychoanalysis*. (Maurice Apprey, Trans.) Pittsburgh, PA: Duquesne University Press. (Original work published 1928)
- . (1969). *Écrits 2*. (J. Debouzy, Ed.) Paris: Éditions Sociales.

## PORTO-CARRERO, JULIO PIRES (1887–1937)

This Brazilian psychiatrist was born at Pernambuco in northeast Brazil on September 7, 1887, and died in Rio de Janeiro on December 30, 1937.

He studied medicine at Rio de Janeiro, specialized in psychiatry, and became a full professor of forensic medicine in the law faculty. A disciple of Juliano Moreira and “wild psychoanalysis,” he used Freud’s method as early as 1924 and was the most important precursor of the psychoanalytic movement in Rio. Sponsored by Durval Marcondes, he founded an affiliate society of the Sociedade brasileira psicanálise in 1928 with Juliano Moreira as president and himself as secretary.

Between 1929 and 1934 he wrote seven works on psychoanalysis. In the first, *Ensaio de psicanálise* (1929, *Essays on Psychoanalysis*), he displayed a good knowledge of the works of the great psychoanalysts. These essays consist of different articles and papers dating back to 1925. The first chapter, “The Concept and History of Psychoanalysis,” is very important in terms of historical data. In the article “Clinical Aspects of Psychoanalysis” (1925), he declared: “Sooner or later, it will become standard practice to apply psychoanalysis to daily life, to pedagogy, to trade even, to military training, to legal investigations and to penitentiary systems.” In “A Brief Notion of Psychoanalysis” (1927), he wrote: “Thanks to this concept, we have a better understanding than before of how civilization developed, the genesis of languages, the origin of myths and legends, the reason behind works of art and the motives for professional vocations.”

In his course, “Psychoanalysis Applied to Education” (1928), given with Deodato de Moraes, we read: “Although psychoanalysis was initially therapeutic [...] it has invaded the sphere of the mind sciences.” He demonstrated the evolution of Freudian ideas and responded objectively to Freud’s critics. Other articles revealed his researcher’s spirit. Finally, in “The Value of Psychoanalysis” (1931), he described his personal experience, his doubts and certainties, his positive and negative results. His limits, in terms of the technique he accepted, came from his lack of analytical training. He also translated Freud’s *The Future of an Illusion* (1927).

As a renowned professor of forensic medicine, he stressed the necessity of having a human and a psychoanalytic understanding of the criminal. He enjoyed

great influence in student circles and among the intellectual elite and paved the way for the future psychoanalysts of the 1940s.

He was in the habit of organizing musical receptions in which he played an active part. On the evening of December 30, 1937, just as his guests were arriving, he felt ill and suddenly died.

MARIALZIRA PERESTRELLO

*See also:* Brazil.

### Bibliography

Perestrello, Marialzira. (1986). Primeiros encontros com a psicanálise, 1899–1937; Os precursores do movimento psicanalítico no Brasil, 1899–1937. *Jornal Brasileiro de Psicanálise*, 35, 4, 195–208.

Porto-Carrero, Julio Pires. ([1929] 1934). *Ensaio de psicanálise*. Rio de Janeiro: Flores e Mano, 2d ed.

———. ([1932] 1934). *Psicologia profunda ou psicanálise*. Rio de Janeiro: Irmãos Pongetti.

———. (1934). *Grandezas e misérias do sexo*. Rio de Janeiro: Irmãos Pongetti.

## PORTUGAL

Before psychoanalysis was institutionalized in Portugal, certain cultural events paved the way for the reception that Freud’s doctrines were later to receive. It is widely accepted that the birth of psychoanalysis in France and Austria was influenced by experiments relating to hypnosis (Mesmer and Charcot). Similarly, we can say that in Portugal José Custódio de Faria (1756–1819), known as Abbé Faria, was an important precursor. Born in Goa, he studied theology in Lisbon and Rome before becoming a priest. He was in Paris in the troubled days of the French Revolution and the Empire, and it was there that he became a disciple of the magnetists. He studied under Mesmer and Puységur, and the theories he presented in his book, *De la cause du sommeil lucide* (1819, *The Cause of Lucid Sleep*), were ahead of his time — he was the first to abandon theories of magnetic fluids and anticipated his contemporaries in his descriptions of post-hypnotic suggestion.

The impact of Freud’s discoveries began to be felt in Portugal at the beginning of the twentieth century. Egas Moniz (1874–1955) was the first to present the

bases for Freud's theory. Moniz had taken an interest in sexology early in his career, and in 1901 he published a book entitled *Sexual Life (Physiology and Pathology)*, which ran to several thousand copies in a few years. In 1925 he published a remarkable biography of Abbé Faria. Because Moniz was preoccupied with sexual life and hypnotism, it was only logical for him to take an interest in psychoanalysis also. In fact, between 1915 and 1925 he published several articles on psychoanalytic theory and method. In two of these articles Moniz described two long cures of neurotic patients, with whom he used the couch, free association, and dream interpretation. In both cases he managed to resolve the neurotic conflicts by having recourse to psychoanalytic psychotherapy. As time went by Moniz's activities centered increasingly on neurological problems. After he discovered cerebral angiography (1927), for which he won the Nobel Prize, he devoted himself entirely to neurology—to the exclusion of psychotherapy and the sexual life. We may well wonder how the psychoanalytic movement would have evolved in Portugal if Moniz, who really was a man of genius, had continued with his initial research and joined Freud's Viennese circle instead of going to work in Paris with Pierre Marie, Jules Déjerine, and Joseph Babinski.

Other psychiatrists, like Sobral Cid (1877–1941), a professor of psychiatry at the university of Lisbon, and Diogo Furtado (1906–1963), one of the most brilliant neuro-psychiatrists of his day, manifested great interest in the theory of psychoanalysis. But they did not continue Moniz's therapeutic work, nor his observations.

After these false starts, a Portuguese psychoanalytic movement finally saw the light of day in the 1950s. Portuguese physicians, beginning with Francisco Alvim and Pedro Luzes, went to Switzerland to train in Raymond de Saussure's Geneva group. They became full members of the Swiss Society and met in Geneva with Spanish analysts who were also in training there (Pedro Bofill, Pere Folch Mateu, and José Rallo Romero).

Together they decided to organize the Luso-Spanish Psychoanalytic Society, which the International Psychoanalytic Association (IPA) recognized as a study group at the Paris Congress in 1957. Two years later this study group was admitted as a component society at the Copenhagen Congress. The Luso-Spanish Society continued to grow, with the addition of ana-

lysts who were generally trained abroad, but training progressively came to be set up in Spain and Portugal.

In 1966, the Iberian group split because of problems of distance and other difficulties, giving birth to the Portuguese study group. Although the IPA may have granted the Luso-Spanish Society the status of a component society somewhat prematurely, too much time was allowed to pass before the Portuguese study group was recognized as a provisional society (1977) and then a component society (at the Helsinki Congress in 1981). This can largely be explained by the change in the IPA statutes, which became increasingly demanding in terms of the required number of members, with benchmarks being used to establish intermediary stages.

The title "Portuguese Psychoanalytic Society" nevertheless began to be used (locally) in 1971. Prior to 1981, several international meetings and congresses had already been held in Portugal. In 1968, the twenty-ninth Congress of Romance-Language Psychoanalysts was organized in Lisbon. Pedro Luzes presented a report entitled "Thinking Disorders in Clinical Psychoanalysis." It was one of the first works from outside Great Britain to stress the importance of Bion's research into thinking. In 1978 the second Conference of the European Federation of Psychoanalysis was held in Estoril on the theme: "The Narcissism of the Psychoanalyst." In 1980, again in Estoril, the First World Congress on Infant Psychiatry, dedicated to the memory of René Spitz, focused on normal and pathological aspects in the first two years of infant life. The forty-fourth and fifty-fourth Congresses of French-Speaking Psychoanalysts met in Estoril and Lisbon, respectively, in 1984 and 1994.

Since 1989, biennial Iberian congresses of psychoanalysis have brought together the Portuguese Society, the Spanish Society (with its headquarters in Barcelona), and the Madrid Psychoanalytic Association. Together these institutions publish the *Iberian Directory of Psychoanalysis* in the Castilian language.

In 1975, the Portuguese Psychoanalytic Society inaugurated an Institute of Psychoanalysis. As a center for psychoanalytic treatment its main function is to provide assistance. It is also active in providing psychoanalytic training. In addition to ten consulting chambers, the institute has several meeting rooms and an ample library containing all the most essential psychoanalytic books and reviews. The Society publishes

the *Portuguese Review of Psychoanalysis* every semester. The first issue appeared in 1985. In terms of scientific activities and dissemination of psychoanalysis, it is important to mention the scientific encounters that usually take place twice a year, called symposia (when predominantly clinical) and seminars (when predominantly cultural).

The problem of schools and divergent currents in psychoanalysis made its presence felt in Portugal, as everywhere else, though perhaps less acutely than in other countries, probably because in the context of a small society deep rifts and intense rivalries run the risk of destroying the analytic group. In the period between the 1940s and the 1980s, when the Portuguese Psychoanalytic Society was finding its feet, the opposition between so-called Freudian (also called “classical”) analysts and Kleinian analysts came to a head. In the Freudian camp were Francisco Alvim (who trained in Raymond de Saussure’s group in Geneva) and João dos Santos (who trained in Paris). Kleinian ideas were introduced to Portugal by Pedro Luzes who, while working in the same Geneva group as Alvim, was also analyzed by Marcelle Spira (a Swiss analyst who received Kleinian training in Argentina). The Freudian nucleus sought support from the Paris Psychoanalytic Society. Beginning in 1962, Pierre Luquet, its representative in Portugal, provided regular teaching for more than twenty years. The Kleinian group received more limited support from the British. Today the theoretical ideas of most of the members and students in the Portuguese Society are mixed, having both Freudian and Kleinian roots. This epistemological constitution is close to what the British call Group B. The Portuguese Psychoanalytic Society recently undertook the task of institutionalizing the training of child psychoanalysts among young analysts and candidates. To do so they relied mainly on French analysts (Florence Guignard, Annie Anzieu, Jean Bégoïn, Didier Houzel, Donald Meltzer, and Antonino Ferro).

Several tendencies claiming to have a dynamic model of the mental continue to evolve along parallel lines. Some, being analytical, take their inspiration from the teachings of Jacques Lacan. Others are influenced by the systemic current (group analysis and family therapy). The psychoanalytic trend as defined above nevertheless dominates all of these movements.

PEDRO LUZES

### **Bibliography**

- Chemouni, Jacquy. (1990) *Histoire du mouvement psychanalytique*. Paris: Presses Universitaires de France.
- Luzes, Pedro. (1979). Four recently discovered letters by Freud to a Portuguese correspondent. A contribution to the pre-history of psychoanalysis in Portugal. *International Review of Psycho-Analysis*, 6, 437–440.

---

## **POSTNATAL/POSTPARTUM DEPRESSION**

The term *postnatal* (or *postpartum*) *depression* describes a condition occurring in a woman after giving birth to her child. The symptoms are depression, anxiety, lack of interest in the baby, and feelings of inadequacy and incompetence as a mother. It occurs among 10 to 15 percent of mothers after delivery, with onset at five to eight weeks after delivery. It is underestimated by professionals and often denied by women, who usually do not seek medical advice. It commonly lasts six months to a year or longer. It causes a lack of attunement in the mother and infant dyad and can lead to early developmental and psychosomatic problems in the baby, making diagnosis and treatment essential (Murray, L., et al., 1991; Mazet, P., 1997). Jeni Holden et al. (1989) demonstrated the therapeutic efficacy of nondirective psychological interviews; A. F. Henderson et al. (1991) note the positive effects of estrogen therapy; R. Channi Kumar et al. (1984) and Donald Meltzer emphasize the need for professionals to coordinate their efforts in treating this pathology, which is still poorly understood and is situated at the intersection of obstetrics, pediatrics, and health services.

B. Pitt (1968) gave the first description of an “atypical postnatal depression” that affected a minority of women, but occurred at a rate of 10.8 percent in a sample of 305 women after delivery. The Edinburgh Postnatal Depression Scale (EPDS), a questionnaire for mothers developed and validated by John Cox et al. (1987), John Cox and Jeni Holden (1994), and Nicole Guedeney et al. in France (1995), makes it possible to diagnose postnatal depression from the sixth week after delivery (when the postnatal obstetrical visit is usually scheduled).

Postnatal depression can be classed among other postnatal psychiatric conditions, ranging from the blues to postpartum traumatic neuroses (Bydlowski and Raoul-Duval, 1978) and the acute postpartum

psychoses that have been described since the nineteenth century (Marcé, L.-V., 1858). In a psychodynamic study, Paul-Claude Racamier et al. (1961) developed the concept of “maternity.” The event of childbirth occasions reversible changes in the psyche whose transparency has been described by Monique Bydlowski (1997). This involves, on the one hand, a reactivation of the themes of the young woman’s infantile neuroses, namely castration anxiety and the avatars of her pre-oedipal links to her own mother, and, on the other hand, a particular capacity for regression that enables her to achieve a psychic functioning that is more in tune with her newborn, as Donald Winnicott showed (1956). The conflicted development of this maternity is theorized as being the origin of some psychopathologies.

Postnatal depression differs from a depressive state in the strict sense, in that anxiety and the mother’s feelings of inadequacy it produces often dominate the picture. It should also be distinguished from postpartum blues (Yalom, I., et al., 1968; Kennerley, H., et al., 1989), a reaction whose peak frequency occurs on the third day after delivery and which affects half of all women; it is characterized by irritability, mood swings, and crying spells, with spontaneous resolution in one to ten days. A particularly lasting or intense case of the blues may be an indicator of the subsequent likelihood of true postnatal depression (Fossey, L., et al., 1997).

MONIQUE BYDLOWSKI

See also: Depression; Maternal; Infant observation (therapeutic); Infantile psychosis.

### **Bibliography**

- Bydlowski, Monique. (1997). *La dette de vie: itinéraire psychanalytique de la maternité*. Paris: Presses Universitaires de France.
- Bydlowski, Monique, and Raoul-Duval, Anne. Un avatar psychique méconnu de la puerpéralité: la névrose traumatique post-obstétricale. *Perspectives psychiatriques*, 68, 321–328.
- Cox, John, and Holden, Jeni (eds.). (1994). *Perinatal psychiatry: Use and misuse of the Edinburgh Postnatal Depression Scale*. London: Gaskell.
- Cox, John L., Holden, Jeni M., and Sagovsky, R. (1987). Detection of postnatal depression. *British Journal of Psychotherapy*, 150, 782–786.
- Fossey Luc, Papiernik, E., and Bydlowski Monique. (1997). Postpartum blues: A clinical syndrome and predictor of postnatal depression. *Journal of Psychosomatic Obstetric Gynecology*, 18, 17–21.
- Guedeney, Nicole, Fermanian, J., Guelfi, J.D., Delour, M. (1995). Premiers résultats de la traduction de l’Edinburgh post-natal depression scale sur une population parisienne. *Devenir*, 7 (2), 69–90.
- Henderson, A F, Gregoire, A J, Kumar, RD, Studd, JW. (1991). Treatment of severe postnatal depression with oestradiol skin patches. *Lancet*, 338, 816–17.
- Holden, Jeni, Sagovsky R, and Cox, John L. (1989). Counseling in a General Practice Setting: A controlled study of health visitor intervention in treatment of postnatal depression. *British Medical Journal*, 298, 223–226.
- Kennerley, H, Gath, D. (1989, Sept.). Maternity blues I. Detection and measurement by questionnaire. *British Journal of Psychotherapy*, 155, 356–62
- Kumar R. Channi, Robson KM. (1984). A prospective study of emotional disorders in childbearing women. *British Journal of Psychotherapy*, 144, 35–47.
- Marcé, Louis-Victor. (1958). *Traité de la folie des femmes enceintes, des nouvelles accouchées et des nourrices et considérations médico-légales qui se rattachent à ce sujet*. Paris: Bailliére.
- Mazet, Philippe. (1997). Quels sont les particularités cliniques des troubles dépressifs chez le nourrisson? In *Les troubles dépressifs chez l’enfant: reconnaître, soigner, prévenir, devenir* (pp. 25–32). Paris: Frison-Roche.
- Murray, L., Cooper, PJ., and Stein, A. (1991). Postnatal depression and infant development. *British Medical Journal*, 302, 978–979.
- Pitt, B. (1968). “Atypical” Depression Following Childbirth. *British Journal of Psychotherapy*, 114, 1325–1335.
- Racamier, Paul-Claude. La mère et l’enfant dans les psychoses du post-partum. *Evolution Psychiatrique* 1961, 26, 4: 526–570.
- Winnicott, Donald W. (1956). *Primary maternal preoccupation. Collected papers, Through paediatrics to psychoanalysis* (pp. 300–305). London: Tavistock, 1958.
- Yalom, Irwin D, Lunde, T, Moos, RH and Hamburg, DA. (1968). “Postpartum Blues” syndrome. *Arch Gen Psychiat*, 18: 16–27.

---

### **PÖTZL, OTTO (1877–1962)**

Otto Pötzl, the Austrian physician and psychiatrist, was born in Vienna on October 29, 1877, and died there on April 1, 1962.

His father, the writer Eduard Pözl, came from a Catholic family and was a freeman of the city. Otto Pözl finished his medical studies in the medical faculty of Vienna University in 1907 and specialized in psychiatry and neurology. From 1905 to 1921, he worked first as an assistant then as chief medical officer in Julius Wagner-Jauregg's neuro-psychiatric clinic in Vienna. In 1911 he took a qualifying exam for specialists in psychiatry and neurology and in 1919 he was appointed professor extraordinary at the university. From 1922 to 1928, Pözl was professor of psychiatry in Prague and in 1928 he succeeded Wagner-Jauregg in Vienna.

Pözl was one of the most respected representatives of the Viennese school of psychiatry. One of his lectures at Vienna University, in which he presented experimental research into dreams and thus confirmed the Freudian theory, led Freud to invite him to attend the sessions of the Vienna Psychoanalytic Society. In June 1917 he delivered a paper on the theme of "Experimentally provoked dream images as an illustration of Freudian dream analysis." Six months later he was admitted as a member of the society. Although some considered his attitude to psychoanalysis to be ambivalent, several of Freud's students were trained in his clinic and Pözl remained a member of the society until 1933. His scientific work, however, had no impact at all on clinical psychoanalysis.

He gave speeches at the ceremonies organized to celebrate the eightieth and hundredth anniversaries of Freud's birth.

In a letter to Freud, Pözl wrote: "[...] I cannot imagine my teaching work without psychoanalysis. My audience and I are your fervent supporters" (Jones E., 1953–1957, p. 255).

Pözl remained president of the university neuro-psychiatric clinic until 1945, when he retired.

ELKE MÜHLEITNER

See also: Austria.

### **Bibliography**

Jones, Ernest. (1953–1957). *Sigmund Freud. Life and work*. London: Hogarth.

Mühlleitner, Elke. (1992). *Biographisches lexikon der psychoanalyse (Die mitglieder der psychologischen Mittwoch-Gesellschaft und der Wiener Psychoanalytischen Vereinigung 1902–1938)*. Tübingen: Diskord.

Pözl, Otto. (1917). Experimentell erregte Traumbilder in ihren beziehungen zum indirekten sehen. *Zeitschrift für die gesamte Neurologie und Psychiatrie*, 37. 3–4.

———. (1960). Preconscious stimulation in dreams, associations, and images. In *Classical studies*, with Allers, Rudolf, and Teler, Jakob. New York: International Universities Press.

Pözl, Otto, with Economo, C., Pick, E., Molitor, H., and Strasser, A. (1929). *Der Schlaf. Mitteilungen und Stellungnahme zum derzeitigen Stande des Schlafproblems*. Munich.

---

## **PRECONCEPTION**

In the strict sense, the term "preconception" in the work of Wilfred R. Bion refers to a necessary antecedent to all forms of thought (be it a conception, concept, or deductive system). When a preconception is "realized," that is, comes into contact with sensory data close to it, it becomes a conception and a concept. Bion later greatly expanded and generalized this notion.

In Bion's theory, preconception functions like the categories in Emmanuel Kant's epistemological theory, that is, as an innate predisposition to receive certain information, as the form of thought. The term designates a state of expectancy.

This formulation theoretically grounds the innate character of preconception. The example of preconception that Bion repeatedly gives, the nursling's expectation of the breast that provides nourishment, suggests Freud's notion of primal fantasies. From this perspective, the infant need not receive, for example, a threat of castration to be subject to the castration complex, because the infant can have primal fantasies of sexual mutilation.

Later, in his *Elements of Psycho-Analysis* (1963), Bion readjusted the term and eliminated references to the innate and phylogenetic aspects of preconception. With regard to his grid, Bion explained that each element along the vertical axis functions as a preconception relative to the terms that follow on the same line, with the exception of the saturated beta elements. In addition, the grid as a whole functions as a preconception. The analyst's free-floating attention is also like preconception, in that it involves a state of expectation induced in the analyst by the analyst's personality and training.

With the aim of producing a more abstract and expanded formulation, Bion proposed representing preconception by means of a function (preconception) and an unknown variable (realization). Once a realization becomes known (agitation, curiosity, castration, etc.), it becomes a constant.

Bion developed the term “preconception” by generalizing and concretizing it, yet such development does not fully comport with the genetic importance that Bion attributed to it in the formation of thoughts or with its epistemological role in resolving certain conundrums of psychoanalysis (empiricism versus innatism).

PEDRO LUZES

*See also:* Concept; Container-contained; Grid; Memoirs of the future; Realization; Reverie.

### **Bibliography**

Bion, Wilfred R. (1962a). *Learning from experience*. London: Heinemann.

———. (1962b). A theory of thinking. *International Journal of Psycho-Analysis*, 43, 306–310.

———. (1963). *Elements of psycho-analysis*. London: Heinemann.

---

## **PRECONSCIOUS, THE**

Already, in his 1896 letters to Wilhelm Fleiss (“Extracts from the Fliess Papers,” 1950a), Freud connected the preconscious associated with verbal representations as being the ego. The full definition of the preconscious emerged only within the delineation of the first topographical theory, although it was never precisely formulated.

The preconscious (*Pcs.*) can only be conceived in opposition to the unconscious (*Ucs.*): It is the very differentiation between the two that makes it possible to think of a topography of the mind. The *Pcs.* is the antagonist of the *Ucs.*; the former is separated from the latter by censorship, the barrier of repression. As the agent of repression, the *Pcs.* is what provides the forces necessary (anticathexes) to maintaining unconscious representations in the unconscious.

The modes of functioning of the *Pcs.* system are different from those of the *Ucs.* in that energy is bound there and that the secondary processes and the reality principle are dominant.

To understand the antagonistic function of the *Pcs.*, it is necessary to let go of the idea—which is nevertheless suggested by its name—of a sort of gradation in the capacity for material to become conscious. That idea was nonetheless present in Freud’s work when he adopted the point of view of a descriptive unconscious, defined relative to consciousness. What was preconscious was then considered as unconscious in the phenomenological sense, readily and by right accessible to consciousness. This usage of the term, most often as an adjective, was thus in contradiction with the notion of two opposing systems, with the preconscious preventing the penetration into consciousness of unconscious contents. The contradiction was only transcended within the context of analysis itself, when the process of becoming conscious was studied. Thereafter, the preconscious took on the role of an intermediary between unconscious contents and their coming into conscious awareness.

The specificity of the preconscious lies in its connection to language. In “The Unconscious” (1915e), Freud wrote: “The system *Ucs.* contains the thing-cathexes of the objects, the first and true object-cathexes; the system *Pcs.* comes about by this thing-presentation being hypercathexed through being linked with the word-presentations corresponding to it” (pp. 201–202). It is thus the perspective of treatment (the “talking cure”) that made it possible to grasp the specificity of the preconscious. Through the work of analysis, representations of things, that is, the contents of the unconscious, are put into relation with the word-presentations that can then make it possible for them to come into conscious awareness. The preconscious is the place where this transposition into words, this link between words and the unconscious thing, takes place.

This notion of the preconscious as the intermediary between the unconscious and consciousness, between thing-presentations and word-presentations, between the primary and secondary processes, was maintained and amplified in psychoanalytic work over the course of time. The preconscious is now considered a locus of exchange and psychic work. Attributed to it are qualities of richness and permanence that vary from one individual to the next and can be used as the criteria for analyzability.

While Freudian metapsychology, dominated by the idea of repression and its role in neurosis, does make it possible to conceive of an impoverished preconscious, cases of atypical, nonneurotic patients, in particular psychosomatic patients, drew the attention of the psychosomatic school of Paris under the aegis of Pierre

Marty. Marty gave the preconscious a central place in his conception of mental functioning, and as a result there is an emphasis in his theory on its role as an organizer, a regulator of not only psychic but also somatic balance. Marty's thinking concerned qualities that are present in varying degrees in the preconscious: its richness, breadth, mobility, and permanence. Richness and mobility refer to the multiplicity of symbolic derivatives in the unconscious capable of interacting in this intermediary zone with word-presentations, themselves multiple and available. The notion of breadth, evocative of the density of this network of representations, also leads to the idea of the preconscious playing the role of an internal protective shield that makes possible the protection of the ego against assaults from the drives and the external world. Permanence has to do with the capacity for lasting and stable functioning.

A sound organization of the preconscious goes hand in hand with sound mentalization, whereas occasional or long-term weakness can lead to what the French psychosomatic school called "operative" functioning, essential depression, or character and behavioral neuroses, as these are described in Marty's classification. By contrast, sound functioning of the preconscious guarantees a rich capacity for fantasizing.

ANDRÉE BAUDUIN

*See also:* Agency; Amentia; Anticathexis/counter-cathexis; Cathectic energy; Censorship; Consciousness; Cure; Day's residues; Desexualization; *Ego and the Id, The*; Essential depression; Evenly-suspended attention; Forgetting; Humor; Hypercathexis; Insight; Metapsychology; Multilingualism and psychoanalysis; Operational thinking; Perception-consciousness (Pcpt.-Cs.); Prereflective unconscious; Primary process/secondary process; Psychic apparatus; Reality principle; Reality testing; Repressed; Repressed, derivative of the/derivative of the unconscious; Repression; Time; Topographical point of view; Unconscious, the; "Unconscious, The"; Wish-fulfillment; Word-presentation.

### **Bibliography**

- Freud, Sigmund. (1915e). The unconscious. *SE*, 14: 159–204.
- . (1950a [1887–1902]). Extracts from the Fliess papers. *SE*, 1: 173–280.
- Marty, Pierre. (180). *Les Mouvements individuels de vie et de mort* (Vol. 2, *L'Ordre psychosomatique*). Paris: Payot.

### **Further Reading**

- Eissler, Kurt R. (1962). On the metapsychology of the preconscious. *Psychoanalytic Study of the Child*, 17, 9–41.
- Hamilton, Virginia. (1996). *The analyst's preconscious*. Hillsdale, NJ: Analytic Press.
- Kantrowitz, Judith. (1999). The role of the preconscious in psychoanalysis. *Journal of the American Psychoanalytic Association*, 47, 65–90.

---

## **PREGENITAL**

The term *pregenital* designates the libidinal phases prior to the definitive, genital organization of psychosexuality.

This adjective first appeared in Sigmund Freud's 1913 article, "The Disposition to Obsessional Neurosis: A Contribution to the Problem of Choice of Neurosis." The idea of a pregenital organization of the libido was introduced in the context of anal erotism. The qualifier "pregenital," which at this point in Freud's work generally defines the child's psychosexual organization, takes into consideration the play of the instincts that are not yet under the primacy of the erotism of the genital zones. Such instincts are called "component" instincts because they remain closely dependent on their somatic sources, they have partial aims, and they function independently of one another. Partial oral and anal sexual activities are supported by the corresponding physiological functions: eating and defecating. In other words, they rely anaclitically on those functions and are thereby instituted as erotogenic zones; their excitability will mark the later genital stage.

In the case of Little Hans, recounted in "Analysis of a Phobia in a Five-Year-Old Boy" (1909b), Freud described an infantile libidinal mode of organization under the sway of an erotogenic zone, namely the genital area. In the boy the Oedipus complex is born of castration anxiety, that is, the fear of being deprived of a precious organ, the penis (as punishment for masturbation). Freud maintained that at this stage, there is a primacy of the male organs for both sexes.

This model, however, based as it was on the boy's libidinal organization, made the case of the girl problematic for Freud and for many of his successors. In his paper on "The Infantile Genital Organization" (1923e), Freud nevertheless clearly assigned the phallic phase of libidinal organization to the pregenital



period. He also revised the general picture of the successive phases of libidinal organization and its polarities. That organization was characterized by the subject/object opposition and its beginnings in the ambivalence of the second stage of the oral phase; then by the opposition, in the anal-sadistic phase, between active and passive. In the next stage, the phallic or infantile genital organization, the phallic/castrated opposition emerged, but this preceded the masculine/feminine opposition. "The complete organization is only achieved at puberty, in a fourth, genital phase," wrote Freud in "An Outline of Psychoanalysis" (1940 [1938], p. 155).

Under these conditions, is it appropriate to call the phallic organization "pregenital"? The very title "The Infantile Genital Organization" invites a negative response; and indeed, the actual use of the term "pregenital" tends to embrace only the oral and anal organizations. However, this same paper of 1923 clearly defines phallic organization as preceding the ultimate genital organization. This question might appear to be purely formal, but it raises substantive issues about libidinal development and the obstacles it encounters, in both sexes, that are not easily clarified.

DOMINIQUE J. ARNOUX

*See also:* Anal-sadistic stage; Archaic; Obsessional neurosis; Oral-sadistic stage; Oral stage; Partial drive.

### **Bibliography**

- Freud, Sigmund. (1909b). Analysis of a phobia in a five-year-old boy. *SE*, 10: 1–149.
- . (1913i). The disposition to obsessional neurosis: a contribution to the problem of choice of neurosis. *SE*, 12: 311–326.
- . (1923). The infantile genital organization. *SE*, 19: 141–145.
- . (1940a [1938]). An outline of psycho-analysis. *SE*, 23: 139–207.

### **Further Reading**

- Blum, Harold P. (1977). The prototype of preoedipal reconstruction. *Journal of the American Psychoanalytic Association*, 25, 757–786.
- Galenson, Eleanor, and Roiphe, Herman. (1980). The preoedipal development of the boy. *Journal of the American Psychoanalytic Association*, 28, 805–828.

Neubauer, Peter B. (1985). Preoedipal objects and object primacy. *Psychoanalytic Study of the Child*, 40, 163–182.

## **PREGNANCY, FANTASY OF**

An infantile fantasy in which the subject, whether masculine or feminine, has the unconscious wish to bear a child, the *fantasy of pregnancy*, which Sigmund Freud links to the enigma of the origin of children and to the fantasy of the primal scene, leads the child to elaborate sexual theories that stage it. In the work of Melanie Klein, this development relates to the creation of an internal object (good or bad). Over the course of psychosexual history, this fantasy has taken on different forms and different meanings.

Freud discusses this unconscious fantasy in connection with dreams in "On Dreams" (1901a); that of pregnancy and the wish for a child in connection with the earliest theories of infantile sexuality in *Three Essays on the Theory of Sexuality* (1905d) and with the Schreber case, in "Psycho-analytic Notes on an Autobiographical Account of a Case of Paranoia (Dementia Paranoides)" (1911c [1910]).

In girls, this fantasy develops in relation either to orality with incorporation, or to anality, where the child-feces becomes a gift given to the mother (between omnipotence and toxicity). The enigma of sexual difference and penis envy, at the genital turning point (penis = infant), feeding on identification with, and hatred of, the mother, cause her to address this fantasy to both parents. Freud situates it as coming second after the onset of penis envy, whereas in Klein's view the girl, through mental bisexuality, wishes to receive a penis from the father; the girl believes she contains children (image of a hollow interior), but may doubt her capacity to bear them. In the girl's oedipal phase, she turns away from her mother and toward the mother's object of desire, the father. The girl demands from him the infant-penis that would make her a mother and worthy of his love; he is supposed to give her what her mother has refused to give her. There is thus a movement from having to receiving, via passivity, and an external demand toward something internal.

Often confused or conflated in the adult woman, the fantasy of pregnancy and the desire for a child situate her within bisexuality: By means of this infant-penis, without renouncing masculinity, she is

inscribed within the feminine position, according to Julia Kristeva in *The Sense and Non-Sense of Revolt*. In feminine homosexuality, this fantasy can aim to neutralize the father, making him a mere progenitor. In boys, this fantasy, often activated by visual contact with the mother or a pregnant woman, is colored by a feminine attitude toward the father, as attested by some frequent themes: bearing embryos after swallowing fruit pits or seeds; escaping from sexual difference by equating feces with a child (a part of the self that must be renounced); aiming to achieve narcissistic completeness in the ambivalence between feminine and masculine, through an identification that passes from creative power to passivity and masochism. Persistence of these infantile traces is found in the traits of homosexuality; in hypochondria; in the fear of having been poisoned and carrying toxic material within oneself; in the notion of being chosen by the gods and impregnated, as in the case of President Schreber, to bring a new humanity into the world; or in the fantasy of self-engenderment (*sui generis*).

Occidental mythology includes various representations of this fantasy: Minerva springing from the head of Jupiter, or Eve being born from Adam's rib. It can happen that the companion of a pregnant woman may experience physical or mental malaise around the time of delivery. The *couvade* (a custom in which the father of a newly born infant engages in certain rites such as being in bed as if he has borne the child himself) is a variation linked to envy of women's creative functions.

MARIE-CLAIRE LANCTÔT BÉLANGER

*See also:* Fantasy.

### **Bibliography**

- Eisler, Michael Joseph. (1921). Womb and birth saving phantasies in dreams. *International Journal of Psycho-Analysis*, 2, 1, 65–67.
- Freud, Sigmund. (1901a). On dreams. *SE*, 5: 629–685.
- . (1905d). Three essays on the theory of sexuality. *SE*, 7: 130–243.
- . (1911). Psycho-analytic notes on an autobiographical account of a case of paranoia (dementia paranoides). *SE*, 12: 9–82.
- Kristeva, Julia. (2000). *The sense and non-sense of revolt* (Jeanine Herman, Trans.). New York: Columbia University Press. (Original work published 1996)

## **PREHISTORY**

Freud used “prehistory” to refer to the most remote past, the “already there,” the psychically innate, and the time before the Oedipus complex. This notion, present in his writings as early as 1888, was made more explicit in chapter 7 of *The Interpretation of Dreams* (1900a). The idea runs through his entire work, and after 1912 (1912–1913a; 1913j; 1918b [1914]; 1985 [1915]) was transformed in a scientific quest to define psychoanalysis as an autonomous natural science of origins. Yet the notion of prehistory was also transformed into a ground for speculating and for pursuing an analogical approach.

From 1912 to 1915, a period of intensive metapsychological theorization, Freud pursued this quest in his investigations and hypotheses with Sándor Ferenczi, himself the exponent of a “metabiology.” Freud also definitively broke with Carl Gustav Jung and invited first-generation psychoanalysts to explore the object of anthropology and ethnology via the clinical method of psychoanalysis (Rank, Róheim). Without ever giving up his theoretical grounding in the drives and libidinal development, Freud introduced the evolutionary views of Charles Darwin, Ernst Haeckel, Jean-Baptiste de Lamarck, Fritz Wittels, and J. J. Atkinson for two primary reasons: to give a new orientation to the problem of how constitutional dispositions relate to individual history, and to make two points of view—ontogenesis versus phylogenesis, or development versus evolution—coherent with one another.

This is a bold hypothesis, fraught with theoretical and clinical consequences in that it affirms not only the universality of the psychic apparatus and the archaic heritage of its disposition and constitution, but also the transmission of content, that is, the lived experience of previous generations. This is not a biological theory, but rather a psychoanalytic theory of the history of the facts and acts that constitute the biological.

Freud asked the reader to abandon phenomenal knowledge in order to conceive of the primal, the genesis of primordial conflict, anxiety in the developmental processes, guilt in evolution, latency, and deferred action. Freud's notions of primitive, primary, primordial, ancient, archaic, and ancestral broaden the notion of prehistory and reveal not only Freud's strong adherence to the evolutionary ideas of his time, but also a need to conceptualize a prior period that defines the

subject's history and that the psychoanalytic process reactualizes during treatment. To explore the various borders encompassing the concept of prehistory, Freud entered into the domains of anthropology, ethnology, paleontology, linguistics, folklore, history of religion, and archaeology.

The notion of prehistory attempts to legitimize the systems of thought of primitive peoples, of children, and of adults to be compared, and also reorders the choices of neuroses inversely to the hypothetical phases of human mental development.

FRANÇOIS SACCO

*See also:* Cultural transmission; Darwin, Darwinism, and psychoanalysis; Heredity of acquired characters; History and psychoanalysis; Infantile amnesia; Identification fantasies; Organic repression; Phylogenesis; *Phylogenetic Fantasy, A: Overview of the Transference Neuroses* Primal, the; Primal fantasies; Primary identification; Psychic temporality; *Psychoanalysis of Fire, The*; Psychotic potential; Totem/totemism.

### **Bibliography**

- Ferenczi, Sándor. (1968). *Thalassa: A theory of genitality* (Henry Alden Bunker, Trans.). New York: W. W. Norton. (Original work published 1924)
- Freud, Sigmund. (1900a). The interpretation of dreams. *SE*, 4: 1–338; 5: 339–625.
- . (1912–1913a). Totem and taboo. *SE*, 13: 1–161.
- . (1913j). The claims of psycho-analysis to scientific interest. *SE*, 13: 163–190.
- . (1918b [1914]). From the history of an infantile neurosis. *SE*, 17: 1–122.
- . (1985 [1915]). *A phylogenetic fantasy: Overview of the transference neuroses* (Axel Hoffer and Peter T. Hoffer, Trans.). Cambridge, MA: Harvard University Press, 1987.
- Rank, Otto. (1909). *Der mythus von der geburt des Helden*. Leipzig, Germany: F. Deuticke.
- Róheim, Géza. (1950). *Psychoanalysis and anthropology: Culture, personality, and the unconscious*. New York: International Universities Press.

## **PREMATURE-PREMATURITY**

A *premature* or *preterm* baby (Voyer, Marcel, and Magny, Jean-François, 1998) is a baby born with fewer than thirty-seven weeks and six days of gestation.

Babies born before the thirty-third week of gestation are considered significantly premature; pregnancies that end earlier than the thirty-first week of gestation pose the greatest problems. Today, the vital and neurodevelopmental prognosis is very good for preterm babies born after thirty-three or more weeks of gestation.

Premature birth disrupts the conditions necessary for the normal development and physiology of the fetus. A new environment must take over the tasks of the maternal placenta, including respiration; the baby's genetically programmed maturation is henceforth dependent on postnatal maturation, prematurely exposed to the outer world (Soulé, Michel, 1992).

Beginning in the 1970s psychoanalysts began making their specific contribution with regard both to the premature baby as person and to parents and caregivers (Satgé, P., and Soulé, 1976). The preterm baby's specific modes of interaction (Di Vitto, Barbara, and Goldberg, Susan, 1979; Field, Tiffany, 1979; Minde, Klaus, 1980), as well as the child's capacities and competence, became better known (T. Berry Brazelton). The notion of the "interactive pattern," which describes different styles of parental interaction, also appeared.

Direct infant observation (that of Esther Bick, and Michel and Geneviève Haag), together with the work of the neo-Kleinians, was applied to hospitalized preterm babies (by Catherine Druon, Joyceline Siksou, and Yolaine Quiniou, among others) and contributed to a closer understanding of the baby's emotional life and bodily states during these first days of life, which are decisive for the foundation of mental life, according to Bernard Golse. Shared observation aims to support, or even treat, the interactive capacities of those participating: mother, father, and caregivers, any of whom may be impeded by the situation or their own personal state. Faced with this exceptional newborn, often closer to a "fetus out in the air" than to their fantasized, imagined baby, the parents find themselves in an almost experimental situation (Kreisler, Léon, and Soulé, 1995).

Psychic trauma can be serious when reality seems to authenticate the fantasies inherent in pregnancy, such as the birth of something strange, or a crisis in parental identity, which are magnified by the preterm birth (Aubert-Godart, Anne, 1998; Friche, Anne, 1998).

The baby's physical prematurity has as its correlate an unfinished pregnancy, mirrored by the prematurity

of the mental process of becoming a parent. The maturation of the internal object is brutally interrupted and the necessary imaginary work during pregnancy of dreams and fantasies regarding the expected baby is suspended. The “unanticipatable” and unrepresentable reality of the newborn, both strange and a stranger, can imprison its parents in a traumatic present.

The parents in the making, persecuted by an amputated pregnancy, a catastrophic birth, and an anxiety-provoking infant, develop intense and ambivalent feelings of strangeness, guilt, and shame, magnified by the necessary separation of hospitalization. The psychopathological risks they run are exacerbated if the parents have fragile personalities. Their mental difficulty in assigning the baby a place within the symbolic universe of the family and transmitting to the child what Serge Lebovici has called the “transgenerational mandate” expresses both their wounded narcissism and their current inability to enter into a relationship with their baby. Therapy sessions are necessary to support their emerging and vacillating sense of parenthood.

In such cases, the team of caregivers relies on a multidisciplinary effort to promote psychical working over, led by the psychiatrist, the psychologist, and the psychoanalyst. Caregivers work together, beyond strict medical or nursing care, to promote a gradual “revelation” of the parents’ nurturing abilities and the overall development of a newborn who is “good enough.”

ANNE FRICHET

*See also:* Infant development

### **Bibliography**

- Aubert-Godart, Anne. (1998). Entre adulte et bébé, l'étrange désordre de la naissance. In *Le bébé, l'intime et l'étrange*. Paris: Érès.
- Druon, Catherine. (1996). *À l'écoute du bébé prématuré: une vie aux portes de la vie*. Paris: Aubier.
- Frichet, Anne. (1998). Intimité perdue, intimité naissante: l'étrange prématuré en quête de familial. In *Le bébé, l'intime, et l'étrange*. Paris: Érès.
- Kreisler, Léon, and Soulé, Michel. (1995). L'enfant prématuré. In *Nouveau traité de psychiatrie de l'enfant et de l'adolescent*. (p. 1893–1915). René Diatkine, et al. (Eds.). Paris: Presses Universitaires de France.
- Soulé, Michel. (1992). *Introduction à la psychiatrie foetale*. Paris: E. S. F.

**PREMATURITY OF HUMAN INFANT.** *See* Helplessness

## **PREMONITORY DREAMS**

A premonitory dream is a dream preceding a real event that seems to foretell its occurrence.

In *The Interpretation of Dreams* (1900a), Sigmund Freud alluded many times to the ancient belief that certain dreams predict the future. In an appendix he added to this work, he described and analyzed this kind of dream from the perspective of wish fulfillment. The following year he stated explicitly: “It is interesting in this connection to observe that the popular belief that dreams always foretell the future is confirmed. The future which the dream actually shows us is not the one which *will* occur but the one which we should *like* to occur” (1901a, p. 674). He later discussed so-called premonitory dreams in connection with the case of the “Rat Man” (1909d).

While obviously, in clinical practice, the belief in the premonitory character of certain dreams cannot be adhered to naïvely, it does make sense to pay very close attention to this belief, when it accompanies the recounting of a dream, often in connection with a sense of “the uncanny.” In the analysis of such dreams the hypothesis of a disguised realization of an unconscious wish has shown itself to be particularly fruitful.

ROGER PERRON

*See also:* Dream; Telepathy.

### **Bibliography**

- Freud, Sigmund. (1900a). The interpretation of dreams. Part I, *SE*, 4: 1–338; Part II, 5: 339–625.
- . (1901a). On dreams. *SE*, 5: 629–685.
- . (1909d). Notes upon a case of obsessional neurosis. *SE*, 10: 151–318.

## **PREPSYCHOSIS**

Prepsychotic states are characterized by precariousness of the neurotic mechanisms, that is to say, “secondary processes” that are too readily invaded by the “primary processes” (Sigmund Freud), resulting in the sudden

appearance of troubling and raw images that cause excessive anxiety and disorganization.

The notion of prepsychosis or prepsychotic states was introduced in 1969 by René Diatkine and Serge Lebovici to account for the lability of symptomatology and appearance of some worrisome clinical configurations in children; the term “prepsychosis” describes states that it would be imprecise, and also detrimental to the child, to try to situate as either neuroses or psychoses.

It was in the context of a psychoanalytic approach to the mental functioning of children that the notion of prepsychosis became necessary. In psychoanalytic clinical work with children as it developed in France between 1960 and 1980, diagnostic and prognostic assessment was not based on a collection of symptoms and behaviors but rather on a psychoanalytic exploration of the mental processes put into play in the child to ensure homeostasis in his or her mental functioning. From this point of view, “neurotic functioning,” as it is observed in “infantile neurosis,” is the most favorable form of psychic organization. “Infantile neurosis” (as part of the Oedipus complex) is thus opposed to “neurosis in children,” which encompasses various pathological conditions.

Clinical psychoanalysis attempts to penetrate beyond manifest symptomatology as exemplified by the psychoanalytic understanding of phobias, wherein a phobia ensures that the anxiety be associated with an avoidable situation and thus that it is an effort to disengage the child’s mental functioning from the risk of being flooded with an excess of anxiety that would be paralyzing. But if this attempt at fixation fails, the possibility of flooding by anxiety despite the phobia remains strong; in this situation large quantities of diffuse, unbound anxiety lead to the massive inhibitions and counterphobic behaviors that define prepsychotic states. But overwhelming anxiety inevitably restricts autonomous mental functioning. Only with difficulty can the mental structures necessary to their development be organized in such children, allowing for sublimations or pleasure in mental functioning that would enable them to ensure the regulation of their mental activity. Their current, apparent neurotic organization does not protect them from breaks in their equilibrium that may cause them to resort to psychotic or aberrant behavior.

Thus, in prepsychotic states the secondary processes are sufficiently developed to ensure, for certain periods

of time or under certain environmental circumstances, a relatively adequate mode of behavior in which the child shows a neurotic type of functioning. However, this functioning can easily be overwhelmed and again flooded by extremely debilitating anxiety and by the primary processes. In the absence of reinforcement by the neurotic mechanisms, a kind of fragility of psychic functioning sets in that will make it difficult for the child as he or she approaches the critical period of adolescence.

The prognosis with such states essentially depends upon the support and reinforcement of the child’s neurotic functioning that can be provided through the child’s social and family environments and psychotherapy treatment. Prepsychotic children’s vulnerability to disorganization also predisposes them to various developmental vicissitudes. Rather than evolving toward fixation in psychotic organization *per se*—which remains a possibility in the mid- or long term—most often such children begin to manifest behavioral disorders: perverse or psychopathic conduct, sexual behavior problems, somatization, substance abuse, and so forth. Another course of development, particularly in young children, is that of inhibited intellectual growth, where the mechanisms of isolation put into effect in an attempt to control being invaded by the primary processes result in impoverished mental functioning and restriction of developmental possibilities.

In itself, then, the term prepsychosis does not have a prognostic value relative to possible psychotic organization later on, but is instead intended to situate the functioning of these children between neurosis and psychosis. The choice of this term has thus often been criticized, and other authors faced with the same clinical reality have proposed such terms as “parapsychosis” (Jean-Louis Lang) or “developmental disharmony” (Roger Misès). The term “borderline conditions” applied to childhood, might also be suitable to describe these intermediary states.

The essential thing, more than the term itself, is the emphasis placed by Diatkine and Lebovici on the specifics of mental functioning in such children and on the need to envisage this phenomenon from a dynamic point of view and not merely from a perspective of diagnostic description.

PAUL DENIS

See also: Blank/nondelusional psychoses; Borderline states; Infantile psychosis.

### **Bibliography**

- Diatkine, René (1969). L'enfant prépsychotique. *Psychiatrie de l'enfant*, 22, 2, 413–446.
- Lang, Jean-Louis. (1978). Aux frontières de la psychose infantile. Paris: Presses Universitaires de France.
- Lebovici, Serge, and A. Le Nestour. (1969). À propos des phobies scolaires graves. *Psychiatrie de l'Enfant*, 20, 2, 383–432.
- Misès, Roger. (1990). *Les pathologies limites de l'enfance*. Paris: Presses Universitaires de France.

---

## **PREREFLECTIVE UNCONSCIOUS**

The term “prereflective unconscious” refers to the shaping of experience by psychological structures (organizing principles, meanings, schemas, thematic patterns) that operate outside conscious awareness. Experience is shaped by organizing principles without this shaping ordinarily becoming a focus of self-reflection. The patterning and thematizing of experience is therefore said to be prereflectively unconscious.

George E. Atwood and Robert Stolorow first introduced this idea in 1980 and distinguished the prereflective unconscious from Freud’s preconscious, because the former can be made conscious only with great effort, whereas the latter can be made conscious by a simple act of attention. Unlike Freud’s dynamic unconscious, the prereflective unconscious is not the product of defensive activity such as repression. The defenses themselves are seen as a special instance of organizing activity that is prereflectively unconscious.

The prereflective unconscious became a central construct in the theory of intersubjectivity developed by Robert Stolorow, George A. Atwood, and Bernard Brandchaft. Prereflective structures of experience are pictured as crystallizing within the evolving interplay between the subjective worlds of child and caregivers. Recurring patterns of intersubjective transaction lead to the establishment of invariant principles that unconsciously organize subsequent experiences. These prereflective principles, forged within the child-caregiver system, are seen as the basic building blocks of personality development and as the quintessential focus of psychoanalytic investigation and interpretation.

The prereflective unconscious has features in common with Claude Levi-Strauss’s, Jean Piaget’s, and Jacques Lacan’s ideas about unconscious structures of thought.

The concept of intersubjectively derived prereflective organizing principles is an alternative to the classical notion of unconscious instinctual fantasy.

ROBERT STOLOROW

See also: Unvalidated unconscious.

### **Bibliography**

- Atwood, George E., and Stolorow, Robert D. (1980). Psychoanalytic concepts and the representational world. *Psychoanalysis and Contemporary Thought*, 3, 267–290.
- . (1984). *Structures of subjectivity: Explorations in psychoanalytic phenomenology*. Hillsdale, NJ: The Analytic Press.
- Stolorow, Robert D., and Atwood, George E. (1992). *Contexts of being. The intersubjective foundations of psychological life*. Hillsdale, NJ and London: The Analytic Press.
- Stolorow, Robert D., Brandchaft, Bernard, and Atwood, George E. (1987). *Psychoanalytic treatment: An intersubjective approach*. Hillsdale, NJ: The Analytic Press.

---

## **PRIMAL FANTASIES**

The term “primal fantasies” connotes those fantasy formations (observation of sexual intercourse between the parents, seduction, castration) which are typical in character in that they transcend individual variations and which in Freud’s hypothesis are part of a phylogenetic inheritance.

Though evoked in “A Case of Paranoia” (1915f), the notion of primal fantasies was essentially bound up with Freud’s reflections on the primal scene, as developed in connection with the “Wolf Man” case (1918b [1914]) and reviewed during the same period in the *Introductory Lectures* (1916–17a).

The subject of primal fantasies brings up three issues: the idea of “typical” mental formations analogous to the sexual theories of childhood; an “origin” of such fantasies antedating the individual’s direct experience (phylogenetic inheritance); and the matter of “origins” in a general sense (what Laplanche and Pontalis [1964] call “fantasies of origins”).

If fantasies arose simply from the individual's particular experience, the work of analysis would be exceedingly complicated; it is precisely the recurrent structures of fantasy narratives and their association with specific psychopathological formations that makes them analyzable. Without going so far as to create a taxonomy, we may say that fantasies are central to complexes with a general character. In the case of the primal fantasies, however, Freud posited their universality inasmuch as they were characteristic of "all neurotics, and probably of all human beings" (1915f, p. 269). It was for this reason, he argued, that primal fantasies must perforce belong to a shared phylogenetic heritage. "It seems to me quite possible that all the things that are told to us to-day in analysis as phantasy . . . were once real occurrences in the primaeval times of the human family, and that children in their phantasies are simply filling in the gaps in individual truth with prehistoric truth" (1916–17a, p. 371).

What is meant, then, are inherited mnemonic traces that the child calls up in order to account for the enigmas he or she encounters: the difference between the sexes, the nature of sexual relations, and so on. As Jean Laplanche and J.-B. Pontalis point out, Freud here found himself once again between the rock of actual events and the hard place of constitutional factors. Transmission may occur, however, via the unconscious of the parents (see "Identification Fantasies," Alain de Mijolla [1981]). Fantasies of this kind tend to echo myth or tragedy (Sophocles, Shakespeare), for the same questions addressed there about the origins of things invariably recur in them: "Fantasies of origins: the primal scene pictures the origin of the individual; fantasies of seduction, the origin and upsurge of sexuality; fantasies of castration, the origin of the difference between the sexes" (Laplanche and Pontalis, 1974, p. 19). The universality of primal fantasies is underscored by the anonymity of the persons involved (1919e), clearly marking such fantasies off from fantasies in which the subject plays a leading part, even from instances where analysis of a fantasy uncovers the presence of the fantasizing subject. This curious characteristic lends these fantasies a seeming incontestability suggesting that they indeed originate from a source other than the individual imagination.

The notion of primal fantasy constitutes a link between the psychoanalysis of social groups and that of individuals, between prehistory and the history of particular subjects.

Freud deployed the phylogenetic thesis as a counterargument to the Jungian idea of retrospective fantasies (*zurückphantasieren*), but in a sense he remained himself trapped by this antithesis. Indeed the psychoanalytical conception of the "primal," as later elaborated, notably by Melanie Klein, abandoned the argument from phylogenesis.

SOPHIE DE MIJOLLA-MELLOR

*See also:* Fantasy.

### **Bibliography**

- Freud, Sigmund. (1915f). A case of paranoia running counter to the psycho-analytic theory of the disease. *SE*, 14: 263–272.
- . (1916–17a [1915–17]). Introductory lectures on psycho-analysis. *SE*, 15–16.
- . (1918b [1914]). From the history of an infantile neurosis. *SE*, 17: 1–122.
- . (1919e). "A child is being beaten": A contribution to the study of the origin of sexual perversions. *SE*, 17: 175–204.
- Laplanche, Jean, and Pontalis, Jean-Bertrand. (1986 [1964]). *Fantasme originaire, fantasme des origines, origine du fantasme. (Fantasy and the origins of sexuality.) Les Temps Modernes*, 215, 1833–68. *International Journal of Psycho-Analysis*, 49 (1968). Reprinted in Victor Burgin, James Donald, and Cora Kaplan, (Eds.), *Formations of fantasy*. London: Methuen, 1986.
- Mijolla, Alain de. (1981) *Les visiteurs du moi, fantasmes d'identification*. Paris: Les Belles Lettres.

### **Further Reading**

- Sherkow, Susan. (2002). The analysis of a pre-adolescent girl with primal scene fantasies. *Psychoanalytic Study of the Child*, 57, 327–354.

---

## **PRIMAL REPRESSION**

The term "primal repression" refers to a hypothetical process postulated by Freud as the originating moment of repression: certain unconscious ideas—the primal repressed material—constitute a "first unconscious nucleus," which then operates as a pole of attraction for elements to be repressed later. "Primal" repression thus complements the work of rejection performed by the censorship or the ego by way of

“repression proper” or “after-pressure” (1915d, p. 148).

The existence of primal repression is in essence inferred from its effects. For repression to succeed, in Freud’s view, some already repressed material must be present, material which, as a truly constraining force, will draw to itself those ideas now marked for repression. But such unconscious attraction cannot suffice. At the same time, and in tandem with it, a pressure must also come into play from the opposite direction—a truly “repressive” force. Thus “repression proper” is the outcome of the combined forces of attraction and repulsion as directed toward the psychical representatives of the instinct.

Its prerequisite is that other, older, “primal” repressions should have already deposited material that remains in the shape of unconscious ideas manifesting their presence by attracting—from consciousness into the unconscious—ideas deemed disagreeable or unwelcome. This earliest repressed material constitutes a “nucleus of the Unconscious,” a primordial nucleus that later “exerts an attraction” upon fresh items to be repressed (1926d, p. 94); in this sense the moment of its formation may well be described as “primal.”

In the German term *Urverdrängung*, “primal repression,” the prefix *ur-* denotes this primordial aspect, for it means “original,” “of the origins.” It does not, however, provide any key to the meaning of primal repression. In parallel with *Urvater*, primal father of the horde, and *Urszene*, primal scene, *Urverdrängung* designates the matrix, as it were, of the prohibition on knowledge of that which was formerly known. Seen in this light, primal repression is much more than a postulate; the concept has been described as “an epistemological coup de force” marking the tipping point between the unknowable and the first signs of mental functioning, and as “inaugural and structuring” (Menahem, 1986).

This “phylogenetic” thesis seemed necessary to Freud in respect of the process itself, which had to be explained as the result of both pressure and attraction. “The impelling force is in a sense driven from two extremities, being rooted on the one hand in [its] ‘patrimonial’ foundation and linked on the other to perceptions liable to be unpleasurable. It thus combines the current and the archaic” (Le Guen, 1992).

Treating the attractive force as necessary raises the question of when primal repression occurs: How can a

“first” repression take place before anything has yet been repressed? “We have reason to assume that there is a *primal repression*, a first phase of repression, which consists in the psychical (ideational) representative of the instinct being denied entrance into the conscious. With this a *fixation* is established; the representative in question persists unaltered from then onwards and the instinct remains attached to it” (1915d, p. 148).

Furthermore, repression “demands a persistent expenditure of force” (*ibid.*, p. 151). Freud invokes anticathexis as the mechanism “which represents the permanent expenditure [of energy] of a primal repression, and which also guarantees the permanence of that repression.” Anticathexis is the sole mechanism involved in primal repression; as for “repression proper” or “after-pressure,” the withdrawal of preconscious cathexis also plays a part (1915e, p. 181). During the primitive period when the unconscious itself is constituted, if a force can be directed to the task of counter-cathexis, this can be done only by a differentiated mental agency. Inasmuch as the superego is formed subsequent to primal repression, the ego must be assumed to be the agency responsible here. The establishment of the ego and that of primal repression would thus seem to be correlated.

Although the precise nature and the motor force of this initial anticathexis might be obscure, Freud did offer an economic hypothesis concerning its formation: “It is highly probable that the immediate precipitating causes of primal repressions are quantitative factors such as an excessive degree of excitation and the breaking through of the protective shield against stimuli” (1926d [1925], p. 94).

JEAN-FRANÇOIS RABAIN

*See also:* Anticathexis/counter-cathexis; Intergenerational; Lifting of amnesia; Metonymy; Repression; Thing-presentation; Unconscious, the; Word-presentation.

### **Bibliography**

- Freud, Sigmund. (1915d). Repression. *SE*, 14.  
 ———. (1915e). The unconscious. *SE*, 14.  
 ———. (1926d [1925]). Inhibitions, symptoms and anxiety. *SE*, 20.  
 Le Guen, Claude. (1992). *Le refoulement*. Paris: Presses Universitaires de France.



Menahem, Ruth. (1986). Urverdrängung primaire, originale, originel. *Revue française de Psychanalyse*, 50, 1.

### Further Reading

Frank, A., and Muslin, H. (1967). The development of Freud's concept of primal repression. *Psychoanalytic Study of the Child*, 22, 55–76.

Kinston, W. and Cohen, J. (1986). Primal repression: Clinical and theoretical aspects. *International Journal of Psychoanalysis*, 67, 337–356.

## PRIMAL SCENE

The expression “primal scene” refers to the sight of sexual relations between the parents, as observed, constructed, and/or fantasized by the child and interpreted by the child as a scene of violence. The scene is not understood by the child, remaining enigmatic but at same time provoking sexual excitement.

The term appeared for the first time in Freud's work apropos of the “Wolf Man” case (1918b [1914]), but the notion of a sexual memory experienced too early to have been translated into verbal images, and thus liable to return in the form of conversion symptoms or obsessions, was part of his thinking as early as 1896, as witness his letter of May 30 of that year to Wilhelm Fliess, where he evokes a “surplus of sexuality” that “impedes translation” (1950a, pp. 229–230). Here we are already close to the model of the trauma and its “deferred” effect. The following year, in his letter to Fliess of May 2, Freud gave the approximate age when in his estimation children were liable to “hear things” that they would understand only “subsequently” as six or seven months (*SE* 1, p. 247). The subject of the child's witnessing parental coitus came up as well, albeit in an older child, with the case of “Katharina,” in the *Studies on Hysteria* (1895d), and Freud evoked it yet again in *The Interpretation of Dreams*, with the fantasy of the young man who dreamed of watching his parents copulating during his life in the womb (1900a [addition of 1909], pp. 399–400).

Freud persistently strove to decide whether the primal scene was a fantasy or something actually witnessed; above all, he placed increasing emphasis on the child's own fantasy interpretation of the scene as violence visited upon the mother by the father. He went so far, in “On the Sexual Theories of Children” (1908c,

p. 221), as to find a measure of justification for this interpretation, suggesting that, though the child may exaggerate, the perception of a real repugnance towards sexual intercourse on the part of a mother fearful of another pregnancy may be quite accurate. In the case of “Little Hans,” however, the violence was explained in terms of a prohibition: Hans deemed it analogous to “smashing a window-pane or forcing a way into an enclosed space” (1909b, p. 41).

The fantasy of the primal scene, like the sexual theories of children, is typical in character: it may be encountered in all neurotics, if not in every human being (Freud, 1915f), and it belongs in the category of “primal” fantasies. It appears, however, not to have the same force for all individuals. The case history of the Wolf Man gave Freud the opportunity not only to pursue the issue of the reality of the primal scene, but also to propose the idea that it lay at the root of childhood (and later adult) neurosis: the sexual development of the child was “positively splintered up by it” (1918b [1914], pp. 43–44). Freud later would later assign a central place to the primal scene in his analysis of Marie Bonaparte, although in her case the scene took place between her nanny and a groom (Bonaparte, 1950–53).

Looked upon as an actual event rather than as a pure fantasy reconstructed in a retrospective way (as with Jung's *zurückphantasieren*), the primal scene had a much more marked traumatic impact, and this led Freud to insist on the “reality” of such scenes, thus returning to the debate over event-driven (or “historical”) reality versus psychic reality. Beyond the issue of the scene itself, however, it was the whole subject of fantasy that was thus raised (in Chapter 5 of the Wolf Man case-history [1918b, pp. 48–60]), discussed in terms that would be picked up by Freud again later in “Constructions in Analysis” (1937d).

It was not merely, in Freud's view, that the technique of psychoanalysis demanded that fantasies be treated as realities so as to give their evocation all the force it needed, but also that many “real” scenes were not accessible by way of recollection, but solely by way of dreams. Whether a scene was constructed out of elements observed elsewhere and in a different context (for example, animal coitus transposed to the parents); reconstituted on the basis of clues (such as blood-stained sheets); or indeed observed directly, but at an age when the child still had not the corresponding verbal images at its disposal; did not fundamentally alter

the basic facts of the matter: "I intend on this occasion," wrote Freud, "to close the discussion of the reality of the primal scene with a *non liquet*" (1918b, p. 60).

Melanie Klein's view of the primal scene differed from Freud's, for where Freud saw an enigmatic perception of violence, she saw the child's projective fantasies. Klein describes the primal scene in a way closely resembling Freud's definition of the sexual theories of childhood. These wishes of the infant abound in hostile and destructive tendencies, but the mother is pictured therein as just as dangerous for the father as the father is for her. The sexual relationship between the parents, fantasized as continuous, is also the basis of the "combined-parent figure."

The primal scene is inseparable from the sexual theories of childhood that it serves to create. This disturbing representation, which at once acknowledges and denies the familiar quality of the parents, excludes the child even as it concerns them, as witness the libidinal excitement the child feels in response. The particularity of the primal scene lies in the fact that the subject experiences in a simultaneous and contradictory way the emergence of the unknown within a familiar world, to which they are bound by vital needs, by expectations of pleasure, and by the self-image that it reflects back to them. The lack of common measure between the child's emotional and psychosexual experience and the words that could give an account of the primal scene creates a gulf that the sexual theories of childhood attempt to bridge. A sadistic reading of the scene combines the child's curiosity about both the origin and the end of life in a representation in which death and life are indeed fused.

SOPHIE DE MIJOLLA-MELLOR

*See also:* Action-(re)presentation; Archaic mother; Combined parent figure; Construction/reconstruction; Dead mother complex; Deferred action; Dream symbolism; Family romance; "From the History of an Infantile Neurosis" (Wolf Man); Hysteria; Identification; Infantile neurosis; Infantile sexual curiosity; Invariant; Listening; *Mass Psychology of Fascism, The*; Oedipus complex; Oedipus complex, early; "On the Sexual Theories of Children"; Ontogenesis; Perversion; Pleasure in thinking; Pregnancy, fantasy of; Primal fantasies; Primitive; Sadism; Sexual theories of children; Superego; "Vagina dentata," fantasy of; Word-presentation.

### Bibliography

- Bonaparte, Marie. (1950–53). *Five copy-books*. Translated by Nancy Procter-Gregg. London: Imago.
- Freud, Sigmund. (1900a). The interpretation of dreams. Part I, *SE*, 4: 1–338; Part II, *SE*, 5: 339–625.
- . (1908c). On the sexual theories of children. *SE*, 9: 205–226.
- . (1909b). Analysis of a phobia in a five-year-old boy. *SE*, 10: 1–149.
- . (1915f). A case of paranoia running counter to the psycho-analytic theory of the disease. *SE*, 14: 261–272.
- . (1918b [1914]). From the history of an infantile neurosis. *SE*, 17: 1–122.
- . (1937d). Constructions in analysis. *SE*, 23: 255–269.
- . (1950a [1887–1902]). Extracts from the Fliess papers. *SE*, 1: 173–280.
- Freud, Sigmund, and Breuer, Josef. (1895d). Studies on hysteria. *SE*, 2: 48–106.
- Klein, Melanie. (1961). *Narrative of a child analysis. The conduct of the psychoanalysis of children as seen in the treatment of a ten-year-old boy*. New York: Basic Books.
- Laplanche, Jean. (1989). *New foundations for psychoanalysis* (David Macey, Trans.). Oxford: Blackwell.
- Mijolla-Mellor, Sophie de. (1999). Les Mythes magico-sexuelles sur l'origine et sur la fin. *Topique*, 68.

### Further Reading

- Arlow, Jacob A. (1980). The revenge motive in the primal scene. *Journal of the American Psychoanalytic Association*, 28, 519–542.
- Aron, Lewis. (1995). The internalized primal scene. *Psychoanalytic Dialogues*, 5, 195–238.
- Greenacre, Phyllis. (1973). The primal scene and the sense of reality. *Psychoanalytic Quarterly*, 42, 10–41.

---

## PRIMAL, THE

The term *primal* refers to the totality of representations produced at the very beginning of mental life before there is any differentiation between internal and external, psyche and soma.

The primal should not be confused with the origin of fantasy life, but is an early expression of it and has

its own contents and its own logic. Never directly observable, the primal and its functioning can only be inferred, notably in the processes characteristic of psychosis (although psychosis is not reducible to these).

The primal was not used as the name of a category by Sigmund Freud, who contrasted the primary processes, describing the unconscious system and the free flow of psychic energy, to the secondary processes, describing the preconscious-conscious system and the binding of energy that allows for postponement of satisfaction. Freud felt the need for a term to describe that which is prior to the primary processes and would precede individual life experience, constituting a sort of a priori framework in which the events in the psychic life of each unique individual would be inscribed. In his view, the “archaic heritage forms the nucleus of the unconscious mind” (1919e, p. 204), the equivalent of instincts in animals in that it is innate and inherited based on phylogenetic traces. The primitive phases of the human family thus survive in each individual subject and are rediscovered by the child according to his or her particular life experiences: “In the case of human being...this phylogenetic point of view is partly veiled by the fact that what is at bottom inherited is nevertheless freshly acquired in the development of the individual, probably because the same conditions which originally necessitated its acquisition persist and continue to operate upon each individual” (354–355) (*passim*) (*Introductory Lectures on Psychoanalysis* (1916–1917) [1915–1917]).

Thus, Freud’s thinking on the origins of psychic life did indeed involve a “primal” defined on both a historical level (humanity’s prehistory) and a biological level (the transmission of traces). With his notion of “primal fantasies,” Freud provided some elements of the contents of these traces, but their structure was considered identical to the one that generally exists between all events and their memory traces. The only difference lay in his hypothesis that what has become fantasy was a reality in primal times.

The notion of the primal was studied by later psychoanalysts, not as a phylogenetically inscribed prehistory, but rather as the point of emergence of the earliest representations. In a certain sense, psychoanalytic thinking on the primal has been mainly informed by the Freudian notion of hallucinatory wish-fulfillment (*The Interpretation of Dreams* [1900]). For example, that notion is found in the work of Melanie Klein, who distinguished an “unconscious fantasy” that is linked

to sensation and stems from the instinctual impulses themselves. These fantasies quickly become susceptible to being fixed in the form of visual, kinesthetic, tactile, gustatory, or olfactory images. Only secondarily can these fantasies become associated with representations of external reality, and later, under certain conditions (e.g., analysis or the child’s spontaneous play) capable of being verbally expressed. However, they remain very remote from both words and conscious relational thought, and they are governed by emotional logic (Isaacs). At this level, there is no differentiation between mind and body, since overall primitive experience and the corporeal schemata associated with it are the determining factors. Traces of this primitive functioning are found in psychosis and hypochondria. Working within a Kleinian theoretical model, Wilfred R. Bion in *Learning from Experience* (1962) described the primal as being “at the source of experience,” defining something prior to thought made up of sensory impressions translated into mnemonic traces (alpha elements). The psychotic, who cannot effect this translation, must contend with sensory impressions in a raw form (beta elements) that cannot be represented as thing-presentations or word-presentations. This situation constitutes not a primal functioning of thought but its failure. However, this failure makes it possible to locate what would otherwise have been unfathomable because it normally undergoes transformation.

Clinical experience with psychotic patients also provided Piera Aulagnier with the basis for her development of the notion of the primal. In Aulagnier’s theory, mental activity is made up of three modes of functioning: the primal with the pictogram, the primary with the fantasy, and the secondary with the idea. These three processes go into effect in succession (following a genetic perspective), but then remain active simultaneously. However, as she wrote in *The Violence of Interpretation: From Pictogram to Statement*: “The psychical ‘objects’ produced by the primal are as heterogeneous to the structure of the secondary, as is the structure of the objects of the physical world that the I encounters and of which it will only know the representation that it makes of it” (p. 4). The primal process has its own logic. By pictogram, Aulagnier means a representation corresponding to the requirements imposed by the body on psychic apparatus (cf. the Freudian definition of the instinct). But the pictogram’s main characteristic is that it is unaware of the duality between sensory organ and external object. It

is a relational schema in which the representative is reflected as identical to the world. This implies an extension of the Freudian notion of primary narcissism, but with an original theoretical adjunct. As Aulagnier explained in the same book: “What psychical activity contemplates and cathects in the pictogram is this reflection of itself, which ensures that, between psychical space and the space outside-the-psyche, there exists a relation of reciprocal identity and specularisation” (p. 25).

Aulagnier’s theory of the primal opened the way to a new understanding of psychosis. Psychosis can in no way be considered a regression to a primal mode, although in the destructiveness of the psychotic process we encounter modalities of functioning that are no longer prevalent in other contexts.

SOPHIE DE MIJOLLA-MELLOR

*See also:* Archaic mother; Intergenerational; Myth of origins; Narcissism, primary; Oceanic feeling; Prehistory; Primal fantasies; Primal repression; Primal scene; Primary identification; Primary masochism.

### **Bibliography**

Aulagnier, Piera. (2001). *The violence of interpretation: From pictogram to statement*. (Alan Sheridan, Trans.) Hove, UK, and Philadelphia: Brunner/Routledge. (Original work published 1975)

Bion, Wilfred R. (1962). *Learning from experience*. London: Heinemann; New York: Basic Books.

Freud, Sigmund. (1916–1917 [1915–1917]). Introductory lectures on psychoanalysis. Parts I and II, *SE*, 15; Part III, *SE*, 16.

Isaacs, Susan. (1948). On the nature and function of phantasy. *International Journal of Psycho-Analysis*, 29, 73–97. Reprinted in *Developments in psychoanalysis* by Melanie Klein et al., Joan Rivière (Ed.). London: Hogarth Press, 1952; reprinted New York: Da Capo Press, 1983.

---

**PRIMARY GAIN.** *See* Gain (primary and secondary)

---

## **PRIMARY IDENTIFICATION**

“Whatever the character’s later capacity for resisting the influences of abandoned object-cathexes may turn

out to be, the effects of the first identifications made in earliest childhood will be general and lasting. This leads us back to the origin of the ego ideal; for behind it there lies hidden an individual’s first and most important identification, his identification with the father in his own personal prehistory. This is apparently not in the first instance the consequence or outcome of an object-cathexis; it is a direct and immediate identification and takes place earlier than any object-cathexis. But the object-choices belonging to the first sexual period and relating to the father and mother seem normally to find their outcome in an identification of this kind, and would thus reinforce the primary one (*primäre Identifizierung*.)” (Freud, Sigmund, 1923b, p. 31).

It is rare in Freud, and consequently worthy of special attention, to read in the third chapter of *The Ego and the Id*, the solemnity with which he writes of “an individual’s first and most important identification” (*die erste und bedeutsamste Identifizierung des Individuums* [GW, XIII, p. 259]). This identification is situated in a mythical era, outside of time, a source of the ego ideal; it is called as such here to demonstrate that “be like” comes first, before the interdiction of the superego: “not to be like your father.” The father is what is implied here, even if Freud added in a note at the bottom of the page: “Perhaps it would be safer to say ‘with the parents’; for before a child has arrived at definite knowledge of the difference between the sexes, the lack of a penis, it does not distinguish in value between its father and its mother” (Freud, 1923b, p. 31n).

These quotations underscore how deeply Freud’s work is marked by the notion of “Proton Psuedos,” from the *Project for a Scientific Psychology* (1950c [1895], p. 352ff), which notion is a precursor to the concept of “deferred action.” Father, mother, or parents are equivalent in the logic of the system of this identification, for which the qualification “ontological” might be suitable. One day, two or three years after the crucial moment of identification—it does not matter exactly when—the perception of the anatomical difference must confirm *a posteriori* that the only one who matters in this identification is the bearer of the penis, father or phallic mother (whose image, it should not be forgotten, is reassuring, before becoming frightening), as an avatar of the father. Eventual identifications with the father and mother as such, that is to say differentiated, will surface later only to “reinforce the primary one” (*primäre Identifizierung zu verstärken*).

Interestingly, no “*primary identification*” appears in the translation nor the index of the *Standard Edition*. James Strachey limits himself to speaking of “*first and most important identification*,” then, at the end of the paragraph, “[it] *would thus reinforce the primary one*” (1923b, p. 31). It might be wondered to what extent this omission contributed to the international use and dissemination of this expression with a meaning contrary to its Freudian conception by many authors whose sources were English-language texts.

In effect there have been many discussions of primary identification, which, from Edith Jacobson (1954) up to the current time, has generally been defined as the first phase of the union with the mother, in a still undifferentiated environment (Winnicott, Donald W., 1956); others have even thought of it as the “primal form of affective attachment to an object before an object relation” (Meissner, William W., 1970). León Grinberg (1976) interpreted it as a very archaic object relation of symbiosis, preceding the differentiation of the Self from the object—an idea which was developed further by Joseph Sandler (1960), who described a state of fusion/confusion between the *Self* and the *not-Self*. René Spitz (1957) used the term “primary identification” to signify the undifferentiated stage and the “acrobatics of identification”; the latter includes “identification with gestural language” (Bertha Bornstein), in which imitation is preeminent—as well as “reciprocal identification,” describing the mirror situation between mother and child.

It is evident that the notion of the “father,” so essential in all of the theory and practice of Freud, has been dropped from the concept of primary identification, the theoretical development of which has been especially pursued in the English-language literature, as is clear in the work of R. Horacio Etchegoyen (1985) on the first of the definitions of identification given by Freud in *Group Psychology and the Analysis of the Ego* (1921c): “Identification is the earliest and original form of an emotional tie” (p. 107). Yet authors generally neglect to mention that the first lines of Chapter VII, “Identification,” developed the above formula, to specify that the father is at its core, where is founded “personal prehistory,” in the wake of the murdered father of the primal horde.

Many misunderstandings, consequently, between European and English, American, or South American schools are rooted in different readings of Freud, and

the notion of “primary identification” is a particularly significant example of this.

ALAIN DE MIJOLLA

See also: Abandonment; Fatherhood; Identification.

### Bibliography

- Etchegoyen, R. Horacio. (1985). Identification and its vicissitudes. *International Journal of Psycho-Analysis*, 66, 1, 3–18.
- Freud, Sigmund. (1921c). Group psychology and the analysis of the ego. *SE*, 18: 65–143.
- . (1923b). The ego and the id. *SE*, 19: 1–66.
- . (1950c [1895]). Project for a scientific psychology. *SE*, 1: 281–387.
- Jacobson, Edith. (1954). Contribution to the metapsychology of psychotic identifications. *Journal of the American Psychoanalytic Association*, 2, 239–262.
- Kanzer, Mark (1985). Identification and its vicissitudes. *International Journal of Psycho-Analysis*, 66, 1, 19–30.
- Meissner, William W. (1970). Notes on identification I. Origins in Freud. *Psychoanalytic Quarterly*, 39, 563.
- Sandler, Joseph (1960). On the concept of the superego. *Psychoanalytical Study of Children*, 15, 128–162.

---

## PRIMARY LOVE

*Primary love* is the term proposed by Michael Balint to designate the very first phase of mental development, characterized by a “harmonious relation to an undifferentiated environment” (Balint, 1952), a “mixture that is made harmonious through interpenetration” of the individual and his or her environment. This “inevitable” primitive phase, which is not associated with an erogenous zone, would become the matrix of all other object relations and leave “vestiges and residues . . . in all the later phases.”

This concept is outside the framework of object relations theory, which made its appearance during the thirties and considers the subject no longer isolated but an integral part of his environment. Michael Balint attempted to resolve the theoretical polemic between Vienna and London on the first stages of psychic life (primary narcissism or sadism), by continuing to carry out research in both directions indicated by Freud in *Three Essays on the Theory of Sexuality* (1905d) and *Totem and Taboo* (1912–13a), and by

treating “the development of the individual sexual function and the development of human relations” as inseparable.

Balint emphasized biology—the bond between the mother and the infant is described as a form “biological interdependence”—and object relations, “reactions to the real influence of the world of objects, primarily to the educational methods” that follow. In 1935 Balint made use of the work of Sándor Ferenczi (Ferenczi, 1924/1963) and the predominant role he gave to object relations, as shown in his *Clinical Diary* of 1932: “Life begins with a passive and exclusive love object. Infants do not love. They must be loved” (Ferenczi, 1988/1932). He identified transferences of this type in certain cures and inferred this primitive stage from them.

In 1937 Balint developed a more radical critique of “primary narcissism.” Postulating (with Sándor Ferenczi and Alice Balint) the idea that object relations exist from birth, he suggested replacing the Freudian perspective with the notion of “primary love.” This concept better accounts for subsequent clinical approaches to transference during the treatment of psychotic patients, as well as during treatment of the pre-oedipal material of neuroses: the demand for “primitive,” “naïve,” “innocent” gratification (Balint, 1952), and calm or passionate responses to gratification or frustration by the analyst. During the stage of “primary love” all the infant’s needs are satisfied, but those of the mother are as well; the two protagonists are equally satisfied and gratified. If this satisfaction is lacking (in the infant or the mother), “relational tensions . . . can result in the appearance of all kinds of ego distortions in the infant or neurotic phenomena in the mother.” Balint articulates this stage and its pathologies in a new theory of the “basic fault.” Although the term is not in widespread use and has even been neglected, and in spite of its restriction to dyadic relations, the changes in technique that it brings about in order to avoid “malignant regressions” has influenced analysts of borderline or psychotic patients.

MICHELLE MOREAU RICAUD

See also: Amai, concept of; Basic fault; Hungary.

### Bibliography

Balint, Michael. (1952). *Primary love, and psycho-analytic technique*. London: Hogarth.

———. (1968). *The basic fault. Therapeutic aspects of regression*. London: Tavistock.

Ferenczi, Sándor. (1963). *Thalassa. A theory of genitality* (Henry Alden Bunker, Trans.). New York: W. W. Norton. (Original work published 1924)

———. (1988). *The clinical diary of Sandór Ferenczi* (Judith Dupont, Ed. Michael Balint and Nicola Zarday Jackson, Trans.). Cambridge: Harvard University Press. (Original work published 1932)

---

## PRIMARY MASOCHISM

Primary masochism is identical to erotogenic masochism as defined by Sigmund Freud in “The Economic Problem of Masochism” (1924c). This name makes official masochism’s recognized primacy, at the time, over sadism, which is masochism projected outward.

In *Beyond the Pleasure Principle* (1920g) Freud had already challenged the anteriority of sadism to masochism: “The account that was formerly given of masochism requires emendation as being too sweeping in one respect: there *might* be such a thing as primary masochism—a possibility which I had contested at that time” (p. 55).

The reason for specifying the primary nature of masochism is to underscore an early fusion of the death instinct through and with the life instinct, occurring internally. Accordingly primary masochism also becomes primal in psychic and instinctual life, prior to any object. Benno Rosenberg further developed this Freudian conception by emphasizing masochism’s role as a “guardian over life” and the importance of being able to eroticize increases in tension, and thus unpleasure (1991). This step is indeed essential in tempering satisfaction, thereby opening the way for both hallucinatory wish fulfillment and the constitution of an early internal temporality. At issue, then, is a primary nucleus of the ego.

Primary masochism is opposed to secondary masochism, which is obtained by a double turning around (of sadism back onto the subject and of activity into passivity), as evident in the description of masochism in “Instincts and Their Vicissitudes” (1915c). Given this distinction, the introduction of primary masochism does not invalidate the earlier clinical descriptions. Rosenberg further emphasized that in psychosis, a striking excess of secondary masochism might result not from overly intense sadism, but instead from a far

more basic deficit of primary masochism for which secondary masochism attempts to compensate by means of quantity, in an attempt to complete a deficient instinctual fusion.

DENYS RIBAS

*See also:* Masochism.

### **Bibliography**

- Freud, Sigmund. (1915c). Instincts and their vicissitudes. *SE*, 14: 109–140.
- . (1920g). Beyond the pleasure principle. *SE*, 18: 1–64.
- . (1924c). The economic problem of masochism. *SE*, 19: 155–170.
- Rosenberg, Benno. (1991). *Masochisme mortifère et masochisme gardien de la vie*. Paris: Presses Universitaires de France.

## **PRIMARY NEED**

As early as *The Interpretation of Dreams* (1900a), Sigmund Freud described the movement that leads from need to desire. In *Three Essays on the Theory of Sexuality* (1905d), he specified, “According to some authorities this aggressive element of the sexual instinct is in reality a relic of cannibalistic desires—that is, it is a contribution derived from the apparatus for obtaining mastery, which is concerned with the satisfaction of the other and, ontogenetically, the older of the great instinctual needs” (p. 159). In “Instincts and Their Vicissitudes,” he justified his choice of the term “needs”: “a drive stimulus does not arise from the external world, but from within the organism itself” and acts as a constant force (1915c, p. 118). He then added, “A better term for a drive stimulus is a ‘need.’ What does away with need is ‘satisfaction’” (p. 118–119). In other words, the concept of primary need refers to the endogeneity of the drive and its biological roots.

From then on in Freud’s work, the concept of need lay at the crossroads of two lines of reflection: on the one hand, the theory of anaclisis, and on the other, the question of primitive hallucination. In the theory of anaclisis, sexual life is grafted secondarily from the

satisfaction of the great needs of the organism (concerned with self-preservation). Thus, “Sucking at the mother’s breast is the starting-point of the whole sexual life, the unmatched prototype of every later sexual satisfaction, to which phantasy often enough recurs in times of need” (1916–17a [1915–1916], p. 314).

It is known, however, that primitive hallucination stems from lack and thus from the frustration of need. No doubt the first response to an unsatisfied need is indeed hallucination, it being understood that the acceptance of this response leads to the replacement of the pleasure principle with the reality principle.

Later developments in the attachment theory (Bowlby) gave rise to profound modifications to the concept of need, modifications that again put into question both the theory of anaclisis and the metapsychological theorization of the emergence of thought. Indeed, according to the theories of Bowlby and his followers, the social and relational link is not secondarily derived from the satisfaction of primary needs, but is in itself a need as primordial as the need for self-preservation. Furthermore, the emergence of thought is played out less in the absence than in the presence of the object, which causes schemas of attachment (internally functioning models) to form in the psyche of the infant.

BERNARD GOLSE

*See also:* Abandonment; Addiction; Alcoholism; Anaclisis/anaclitic; Anxiety; Attachment; Borderline conditions; Demand; Dependence; Deprivation; Graph of Desire; Guex, Germaine; Hallucinatory, the; Holding; Oral stage; Primary object; Satisfaction, experience of; Self-object; Subject of the drive; Symbolization, process of; Transference depression; Wish-fulfillment; Wish/yearning.

### **Bibliography**

- Bowlby, John. (1969). *Attachment and loss*. London: Hogarth.
- Freud, Sigmund. (1900a). The interpretation of dreams. *SE*, 4–5.
- . (1905d). Three essays on the theory of sexuality. *SE*, 7: 123–243.
- . (1915c). Instincts and their vicissitudes. *SE*, 14: 109–140.
- . (1916–17a [1915–17]). Introductory lectures on psycho-analysis. *SE*, 15–16.

## PRIMARY OBJECT

The notion of primary object corresponds to the constitution of the object of satisfaction of needs and wishes resulting from the first mother-infant encounter, even before questions of inside/outside, subject/object have been raised. Its incorporation constitutes the kernel of the ego.

Freud postulates the existence of this first encounter beginning in 1895 in the “Project For a Scientific Psychology” (1950c). Nevertheless, a full theory of the primary object would have to wait for Melanie Klein and especially Donald Winnicott in 1952 and Wilfred Bion in 1961.

Freud conceived of the primal psychic apparatus as undifferentiated, in a state of immaturity and distress necessitating maternal care. The object-breast which satisfies need creates the erogenous-oral zone through anaclysis or “leaning.” The inertia principle imposes its conditions on the pleasure/unpleasure principle through the effects of this encounter. Affect-feeling reigns supreme in this primal psychic space, and the experiences of satisfaction and/or dissatisfaction inscribe their traces in it, which makes possible the hallucination of satisfaction via the return [through the trace] and the [re]creation of the object.

For Freud, the “reality ego of the beginning” seeks to constitute itself as a “purified-pleasure-ego”; even though it is “born of hatred” (1915c), which is only apparently contradictory. Unlike Freud, Melanie Klein conceives of the primary psychic space as being from the very first the theater of a completed and active ego animated by drives already attached to their objects, engaged in relationships of love and hatred, desire and gratitude.

Wilfred Bion introduced the “capacity of maternal reverie” as an essential factor in the “alpha function,” whose task is to lend constancy and symbolization to the “beta elements” that the infant expels into it [the maternal reverie] through projective identification.

For Melanie Klein and Wilfred Bion, the drives and the ego are therefore active from birth. Winnicott’s use of the notion of “leaning” remains a bit closer to Freud. He describes a “transitional space” that allows him to suspend the decision between need and desire, internal and external, objective and subjective, primary narcissism and drive. This leads to the notion of the “subjective object,” product of the infant’s “primal

creativity,” which, when exposed to “primal maternal preoccupations,” secures for the experiences of illusion/disillusion necessary to the constitution of this object from the endlessly created and recreated breast.

MARIE EUGENIE JULLIAN MUZZO BENAVIDES

*See also:* Object.

### Bibliography

- Bion, Wilfred. (1961). *Experiences in groups*. London: Tavistock Publications.
- Guignard, Florence. (1997). *Épître à l'objet*. Paris: Presses Universitaires de France.
- Klein, Melanie. (1932). *The psycho-analysis of children*. London: Hogarth.
- Lebovici, Serge. (1983). *Le Nourrisson, la mère et le psychanalyste*. Paris: Le Centurion.
- Winnicott, Donald. (1958). *Collected papers: Through paediatrics to psycho-analysis*. London: Tavistock Publications.

## PRIMARY PROCESS/SECONDARY PROCESS

Freud’s terms “primary process” and “secondary process” designate two opposed yet nevertheless complementary modes of functioning within the psychic apparatus. The primary processes, directly animated by the drives, serve the pleasure principle and work to actualize a free flow of psychic energy. Secondary processes, which presuppose the binding of this energy, intervene as a system of control and regulation in the service of the reality principle. Psychical life is entirely regulated by the equilibrium between these two types of processes, which varies between subjects and at different points in time.

Freud raises the prospect of this fundamental duality as early as his “Project for a Scientific Psychology” (1950c [1895c]), where an entire paragraph is devoted to the complete enunciation of a schema that he would refine over the decades to come. Briefly put, desire or the wish (*le désir*) unleashes a process of discharge. But since in this “precocious phase” the psychic apparatus is not capable of distinguishing between the representation of a missing object and its perception in reality, the fulfillment of the wish is therefore hallucinatory and “requires a criterion from elsewhere in order to distinguish between *perception* and *idea*.” This mode of functioning may be “biologically detrimental”—a



regulation therefore intervenes which makes it possible for the psyche to “distinguish between a perception and a memory (idea)” (p. 324–325) by deferring hallucinatory satisfaction. Thus “wishful cathexis to the point of hallucination . . . which involve a complete expenditure of defense are described by us as psychical primary processes; by contrast, those processes which are only made possible by a good cathexis of the ego, and which represent a moderation of the foregoing, are described as *secondary psychical processes*” (p. 326–327).

This statement is made from within the framework of Freud’s attempt to account for psychic functioning on the basis of an economic hypothesis, that is to say by positing the existence of a specific energy, and, in neurobiological terms, by distinguishing between different types of neurons, and considering the circuits through which this energy circulates between them. He will quickly reject the second hypothesis, but the first will remain central, in that the energy in question, henceforth psychical, is to be re-baptized “libido,” and is given a major application in the case of the dream work, which is conceived from the first as an actualization of desire that transforms latent thoughts into dream images. “The intensities of the individual ideas become capable of discharge *en bloc* and pass over from one idea to another” (1900a, p. 595). Either in mutual displacement, or agglomeration via condensation, this play of unbound energy is characteristic of the primary processes of the dream: “The first wishing seems to have been a hallucinatory cathecting of the memory of satisfaction. Such hallucinations, however, if they were not to be maintained to the point of exhaustion, proved to be inadequate to bring about the cessation of the need, or, accordingly, the pleasure attaching to satisfaction. A second activity—or, as we put it, the activity of a second system became necessary . . .” (p. 598–599). Whereas the activity of the first system, that of the primary processes, is “directed towards securing the free *discharge* of the quantities of excitation,” the second system, that of secondary processes, “succeeds in *inhibiting* this discharge” (p. 599).

The influence of Jacksonian theses defining the neuropsychic apparatus as a hierarchical system of regulating and regulated structures is apparent in this kind of conceptualization. What is also apparent here is Freud taking sides against the positions held by both Josef Breuer and Pierre Janet simultaneously, in that both only tended to account for the weakening of

psychical functioning in the cases of hypnoid states or when the mental *tonus* had been reduced. According to Freud, it is ever indispensable to take an equilibrium between antagonistic forces into account.

This conception is at one and the same time both synchronic and diachronic or, in other terms, both structural and developmental. This is seen clearly in Freud’s commentary on the terms he chooses to designate this opposition-complementarity: “When I described one of the psychical processes occurring in the mental apparatus as the ‘primary’ one, what I had in mind was not merely considerations of relative importance and efficiency; I intended also to choose a name which would give an indication of its chronological priority. It is true that, so far as we know, no psychical apparatus exists which possesses a primary process only, and that such an apparatus is to that extent a theoretical fiction. But this much is a fact: the primary processes are present in the mental apparatus from the first, while it is only during the course of life that the secondary processes unfold” (1900a, p. 603).

Specifying the opposition between the pleasure principle and the reality principle, whereby he posits the pleasure principle as temporally primary, Freud would later write: “It will be rightly objected that an organization which was a slave to the pleasure principle and neglected the reality of the external world could not maintain itself alive for the shortest time, so that it could not have come into existence at all.” His answer which followed was to constitute the keystone of the contemporary development of theories of psychogenesis in their entirety, by bringing the mother-child relationship into consideration: “The utilization of a fiction like this is, however, justified when one considers that the infant—provided one includes with it the care it receives from its mother—does almost realize a psychical system of this kind” (p. 603).

The opposition-complementarity of the primary and secondary processes was therefore described first by Freud in economic terms. However he also accords it a topological dimension. In “The Unconscious” (1915e), he specifies that the Preconscious is the locus of the secondary processes and their regulating function over the primary processes characteristic of the Unconscious. It is this regulation that binds the cathectic energy used for representations, and therefore makes possible the development of thought, which occurs via the passage from thing-representations to word-representations. Indeed the work of

thought, which functions via the “displacement of small quantities of energy” requires that the representations upon which it is based remain stable and distinct. This would not be possible if the free flow of energy, and the condensations and displacements characteristic of the primary processes, prevailed.

ROGER PERRON

*See also:* Act, passage to the; Condensation; Contradiction; Displacement; Dream; Dream symbolism; Dream work; Free energy/bound energy; Fusion/defusion of instincts; Logic(s); Perceptual identity; Process; “Project for a Scientific Psychology, A”; Regression; Representability; Secondary revision; Memories; Thought identity; “Unconscious, The”.

### **Bibliography**

- Freud, Sigmund. (1900a). The interpretation of dreams. Part I, *SE*, 4: 1–338; Part II, *SE*, 5: 339–625.
- . (1915e). The unconscious. *SE*, 14: 159–204.
- . (1950c [1895c]). Project for a scientific psychology. *SE*, 1: 281–387.

## **PRIMITIVE**

The term “primitive” (sometimes “primeval” or “primal”) is close to “archaic,” but should be distinguished from the latter in that “primitive” refers not to origins but rather to an anthropological or historical description of cultural phenomena (myths, religions, legends) or modes of thinking that remain unconscious in modern, civilized humans.

Freud’s interest in the primitive was manifested as early as “A Project for a Scientific Psychology” (1950c [1895]), where he cited Charles Darwin. Thereafter, this notion is always found at the interface between, on the one hand, Freud’s preoccupation with biological evolution and phylogenesis and, on the other, his hypotheses on the formation of social groups, as presented in particular in *Totem and Taboo* (1912–1913a) and *Moses and Monotheism* (1939a [1934–1938]).

In Freud’s hypothesis, as outlined in “On the Universal Tendency to Debasement in the Sphere of Love” (1912d), “primitive” people, although they too live in a civilization remote from archaic times, are the equivalent of the childhood of “civilized” people. Thus everything about them is relevant to the study of

humanity as a whole. Among salient examples of Freud’s use of the term in his work are references to primitive religions and primitive sexual rites of worship (letter to Wilhelm Fliess dated January 24, 1897) and to primitive languages in which, as in dreams, there is no such thing as negation or contradiction (1900a), or in which a word is even systematically used with opposite meanings to express ambivalence (1910e).

In fact, thought itself, at these primitive stages, possesses original characteristics—such as conceptions of death, mechanisms of projection, and sexualized thought—as are found in magical beliefs or animism (1912–1913a). Freud hypothesized that social organization is initially patriarchal (the primal horde), then matriarchal (the divinization of woman as mother and the grouping of brothers into totemic clans), and finally once again patriarchal and patrilineal, with a unique God replacing the primal father. This conception constitutes a model for viewing collective life in general in its different, ever unstable configurations. The notion of the primitive always appears at the boundaries of myth, legend, and history, which are characteristic of the primitive style of writing history (1909d).

The primal scene (when a child is first emotionally aware of his parents copulating) also condenses certain epistemological questions that can be raised about the primitive, particularly concerning the reality of what the small child has seen or heard in connection with the parents’ sexual relations.

The notion of the primitive occupies a central place in Freud’s thought. It is the equivalent, at the collective level, to the infantile at the individual level. This aspect of Freud’s work provides the outlines for fruitful interaction between anthropology and psychoanalysis.

SOPHIE DE MIJOLLA-MELLOR

*See also:* Abel, Carl; Act, passage to the; Animistic thought; Cultural transmission; Darwin, Darwinism, and Psychoanalysis; Ethics; Infantile omnipotence; Knowledge or research, instinct for; Magical thinking; Myth of origins; Oceanic feeling; Organic repression; Phylogenesis; Prehistory; Primal, the; Projection; *Psychoanalysis of Fire, The*; Symbol.

### **Bibliography**

- Freud, Sigmund. (1950c [1895]). A project for a scientific psychology. *SE*, 1: 281–387.

- . (1900a). The interpretation of dreams. *SE*, 4: 1–338; 5: 339–625.
- . (1909d). Notes upon a case of obsessional neurosis. *SE*, 10: 151–318.
- . (1910e). The antithetical meaning of primal words. *SE*, 11: 153–161.
- . (1912d). On the universal tendency to debasement in the sphere of love. *SE*, 11: 177–190.
- . (1912–1913a). Totem and taboo. *SE*, 13: 1–161.
- . (1939a [1934–1938]). Moses and monotheism: Three essays. *SE*, 23: 1–137.
- . (1985). *The complete letters of Sigmund Freud to Wilhelm Fliess, 1887–1904* (Jeffrey Moussaieff Masson, Trans.). Cambridge, MA: Harvard University Press.

## PRIMITIVE AGONY

In psychosis, the original “unthinkable state of affairs that underlies the defense organization” (Winnicott, 1974).

In Winnicott’s developmental schema, the innate “maturational tendency” (of the baby to become integrated as a whole ongoing being) is effective insofar as there exists “a facilitating environment” (which both is and is not provided by an emotionally attuned mother) adapting and developing alongside the developing infant. The infant can then integrate, and eventually object-relate, proceeding from “absolute dependence” to “relative independence.” Winnicott describes “the fear of breakdown” as the fear of re-experiencing the conditions previously feared during failure of the environment, which are described as various degrees and types of “primitive agony,” associated with different defense systems, “disintegration” for example being a defense against unthinkable dread of a return to an “unintegrated state.” These unthinkable fears will be reached in analysis in the transference, and it is during analysis that the feared but not yet experienced (because the subject was not yet integrated enough to experience it) disaster can be known and understood.

Winnicott approached this formulation earlier (Winnicott, 1962) as “unthinkable anxiety,” and on different occasions, and while describing his concept of development used this earlier term. His purpose in using this term was to emphasize that psychotic illness, even “infantile autism” (Winnicott, 1967), is always a

defense organization, and to describe the conditions underlying the establishment of such organizations.

JENNIFER JOHNS

*See also:* Good-enough mother; Negative therapeutic reaction.

## Bibliography

- Winnicott Donald. (1945). Primitive emotional development. In *Collected papers, through paediatrics to psychoanalysis*. (p. 145–156). London: Tavistock Publications, 1958.
- . (1974). Fear of breakdown. *International Review of Psycho-Analysis*, 1, 103–107. Also in *Psychoanalytic explorations*. (p. 87–95). Winnicott, Clare, Shepherd, Ray, and Davis, Madeleine (Eds.). London: Karnac, 1989.
- . (1962). Ego-integration in child development. In *The maturational processes and the facilitating environment*. (p. 56–63). London: Hogarth Press and the Institute of Psycho-Analysis, 1965.
- . (1967). The aetiology of infantile schizophrenia, in terms of adaptive failure. In *Thinking about children*. (p. 218–223). Shepherd, Ray, Johns, Jennifer, and Taylor Robinson, Helen (Eds.). London: Karnac, 1995.

## PRIMITIVE HORDE

Charles Darwin and evolutionist sociologists of the nineteenth century used a term of Tartar origin, “primitive horde,” to refer to the simplest possible form of social formation in existence during prehistoric times. The horde was a link between the state of nature, ultimately unknowable, and the state of culture. The word has also been used by some ethnologists to characterize groups that engage in hunting and gathering in a given territory.

The notion of the primitive horde was described in Darwin’s *The Descent of Man* (1871). Freud, in *Totem and Taboo* (1912–1913a), wrote “Darwin deduced from the habits of the higher apes that men, too, originally lived in comparatively small groups or hordes within which the jealousy of the oldest and strongest male prevented sexual promiscuity.” James Jasper Atkinson returned to this hypothesis in *Primal Law* (1903). He referred to the horde as a “cyclopean family.” Andrew Lang, in *The Secret of the Totem* (1905), also acknowledged Darwin’s theory: “The first practice was that of the jealous Father: ‘no male can touch the females in my camp,’ which was accompanied by the expulsion of the adolescent sons.”

It was Freud, in *Totem and Taboo*, who provided greater insight and scope for Darwin's theory. In spite of the criticisms that appeared when the book was published, he maintained this idea and returned to it again in *Group Psychology and the Analysis of the Ego* (1921c), *The Future of an Illusion* (1927c), and *Civilization and Its Discontents* (1930a [1929]), and especially in his last book, *Moses and Monotheism* (1939a). The importance he assigned to this is reflected by a communication he had with Abram Kardiner in which he wrote, "Don't take this too seriously. It's something I dreamed up one rainy Sunday afternoon."

Freud's principal contribution was the idea of the murder of the Father of the primitive horde: "One day, the brothers who had been driven out, came together, killed and devoured their father and so made an end to the patriarchal horde. United, they had the courage to do and succeeded in doing what would have been impossible for them individually." The collective crime is correlative with the birth of a group and, later, the birth of humanity.

"One day" man was living in a primordial age. To leave it a foundational act was needed, one that was irreversible. Certainly, it is possible that, before this, one of the children in a horde may have succeeded in killing the father. He would then have taken his place and the group would have gone on as before. But it was the unanimous decision of murder ("the brothers came together") that enabled mankind to enter history. For the sons only became brothers when they were able to overcome their powerlessness—which could have (and should have) heightened rivalry among them—and achieve a sense of solidarity. This was a relation in which each recognized the other as an equal, which enabled them to escape the deadly fascination they experienced, that is, the admiration and fear they experienced before the omnipotent father.

Atkinson had already assumed that the "young troop of brothers" had finally acquired strength and had "taken from the paternal tyrant his wife and his life." But he did not see this as a new beginning. Moreover, he failed to make use of another theory that was crucial as far as Freud was concerned, that of William Robertson Smith. Smith, in his *The Religions of the Semites* (1894), had used the totemic meal, during which a sacrificial victim is put to death, as a central element in the ritual reestablishment of the clan, a celebration at which the clan experiences the solemn transgression of a prohibition, a transgression that can

only be justified "if the entire clan shares in the responsibility." For Freud the totemic meal, "which is perhaps mankind's earliest festival, would thus be a repetition and a commemoration of the memorable and criminal deed, which was the beginning of so many things—of social organization, of moral restrictions and of religion." The conspiracy, prepared long in advance, promoted group cohesion. The murder followed by the meal in common made brothers of the sons, a brotherhood of equals, united by the same blood, identifying with the father, and each appropriating, through the act of cannibalism, part of his strength.

However, it is important to remember that due to the ambivalence of feeling, the brothers loved their father as much as they feared him. Moreover, the brothers felt guilty for having killed the father. They then decided to reject the object of desire for which they had banded together: ("what had up to then been prevented by his actual existence was thenceforward prohibited by the sons themselves, in accordance with the psychological procedure so familiar to us in psychoanalysis under the name of 'deferred obedience.'") They idealized and mythified the father they had established as totem, experienced as the founder of the group and the bearer of symbolic law. The world of relations of force gives way to the emergence of a world of alliances and solidarity. In *Moses and Monotheism* Freud returns to this idea. But he insists on the monopolization of speech by the Father of the horde. By killing him, the sons appropriate nascent language (see P. Kaufmann [1979]). As a result of the act, great importance is given to the "omnipotence of ideas that will bring about such extraordinary progress in intellectual activity" and the development of spirituality.

*Totem and Taboo* was strongly criticized by anthropologists. Paul Radin (1929) felt it was a "deplorable performance," Alfred Louis Kroeber, in 1920, rejected Freud's hypothesis, which he denounced as a "conviction without substance." In 1939 he returned to the book and criticized the use of history to cloak a "psychological intuition." In contrast, Géza Róheim, an anthropologist and psychoanalyst, used Freud's grid in his work while focusing on the analysis of the "actual carriers" of culture and forgetting the "bewitching phylogenesis." Claude Lévi-Strauss (1949) took the hypothesis of the murder of the father seriously, not as a historical event but as a "durable and ancient dream" that has even more importance "since the acts it evokes

have never been committed because culture has always and everywhere opposed them.” It was a writer, René Girard, a man opposed to psychoanalysis, who in 1968 praised *Totem and Taboo* in the clearest terms, even though he contested its reasoning. Eugène Enriquez (1967) had already adopted the hypothesis of parricide to explore the notion of power; Serge Moscovici (1981) used Freud’s book to understand the role of the charismatic leader.

It is worth pondering why Freud invented this narrative. The unconscious desire for murder and fantasy would have been sufficient. Didn’t Freud himself say that the only currency used by psychoanalysis was fantasy? Yet, in spite of the clinical data (Sándor Ferenczi’s little man-rooster and Freud’s “Little Hans”), Freud wanted to tie the Oedipus complex to an event. He had always been sensitive to the “act.” (“In the beginning was the act,” as Goethe wrote.) He always believed that ontogenesis reproduced phylogenesis. For Freud it was necessary to inscribe the history of each subject within that of social organization. The work of Ernst Haeckel seemed to provide the best way of doing this. And, by linking this to the origin of religion, he knew that he risked a break with Carl Gustav Jung—a not altogether disagreeable possibility for Freud.

EUGÈNE ENRIQUEZ

*See also:* Alterity; Civilization (*Kultur*); Darwin, Darwinism, and psychoanalysis; Family; Fantasy; Father complex; Heredity of acquired characters; Myth of origins; Oedipus complex; Ontogenesis; Phylogenesis; *Phylogenetic Fantasy, A: Overview of the Transference Neuroses*; Primitive; Sociology and psychoanalysis/sociopsychanalysis; *Totem and Taboo*.

### **Bibliography**

- Enriquez, Eugène. (1983). *De la horde à l'État*. Paris: Gallimard.
- Freud, Sigmund. (1912–1913). Totem and taboo. *SE*, 13: 1–161.
- Kaufmann, Pierre. (1979). *L'Inconscient du politique*. Paris: Presses Universitaires de France.
- Lévi-Strauss, Claude. (1949). *Les structures élémentaires de la parenté*. Paris: Presses Universitaires de France. Reprinted 1968, The Hague: Mouton.
- Moscovici, Serge. (1981). *The age of the crowd: A historical treatise on mass psychology*. (J.C. Whitehouse, Trans.) Cambridge and New York: Cambridge University Press

### **Further Reading**

- Becker, E. (1961). A note on Freud’s primal horde theory. *Psychoanalytic Quarterly*, 30, 413–419.
- Ostow, Mortimer. (1959). A primal horde dream. *Psychoanalytic Quarterly*, 28, 470–480.

---

## **PRINCIPLE OF CONSTANCY**

The *principle of constancy* is the principle of psychic functioning that seeks to maintain the quantity of excitation contained in the apparatus at a low or constant level. This is accomplished through a discharge of the energy present in the apparatus or by avoiding its augmentation.

In 1892, Freud submitted a manuscript and letter to Breuer articulating their common position regarding the thesis of “holding constant the amount of excitation” (1940d). One year later, Freud spoke of a tendency to “shrink” or “diminish” the “amount of excitation,” and trauma was conceived to be a result of its augmentation.

The principle of constancy represented a point of view widely accepted in the sciences of the nineteenth century, such as Fechner’s equilibrium principle (Laplanche and Pontalis, 1967; Laplanche, 1970). Its workings were held to be furnished by mechanisms (in the Freudian sense of acts and behaviors) of avoidance of external excitations, of defense and of discharge (abreaction) in response to increased tension of internal origin.

The principle of constancy is a central feature of the theory developed between 1892 and 1895, introduced in order to account for phenomena observed in hysteria that contradicted this “precondition of health” (1940d). From this point forward symptoms were blamed on a lack of abreaction, and treatment offered adequate discharge. However, Breuer envisaged the law of constancy as optimal, allowing for a free circulation of kinetic energy. In his “Project” of 1895 Freud sought a principle unrelated to healthiness, by sketching out an operation that occurred simultaneously at the heart of and at the extremities of a specific portion of the nervous system. The principle of constancy was thereby supplanted by an inertia principle, according to which certain neurons tend to empty themselves totally of their quantity of excitation. The tendency to

constancy would become a secondary function—a modification of the inertia principle—demanded by the “exigencies of life.” It is confined to the secondary processes of the “ego” where energy is bound, meaning maintained at a certain level in the “psi system.”

In *The Interpretation of Dreams* (1900a) the opposition constancy/inertia serves as a backdrop. The principle of inertia regulated the functioning of the system Ucs. according to the laws of primary functioning. The principle of constancy worked at the level of the Pcs.-Cs. system through cathexes, diversion of inhibitions, and transformations into states of quiescence by raising excitation to even levels. Subsequently, the opposition between the two modes of functioning was most often assimilated to the opposition between the pleasure principle and the reality principle.

Freud finally formulated an explicit “principle of constancy” in *Beyond the Pleasure Principle* (1920g), as the economic basis of the pleasure principle, but he left open the question concerning what level should be aimed at: zero, constant, low, high, etc. However the tendency toward zero that later became the “Nirvana Principle” was considered fundamental. It was in this connection that Freud introduced the death drive. The latter tended toward the absolute reduction of tensions and was opposed to the life drive, which made use of heightened tension levels in its quest to forge and hold onto vital unities.

Freud’s thinking on this matter remains plagued by an unresolved difficulty. Is psychoanalysis limited to a narrow domain, or does it represent an attempt to create a general psychology, meaning a biology? In spite of the “self-preservation/sexuality” distinction, the overlap between vitality and sexuality remained a problem for Freudian theory to work through. Was the energy Freud envisioned energy in general, or sexual energy (cf. Jung)? Did everyday regulatory mechanisms encompass the phenomena of increased quantities of all kinds, or was the augmentation of psychic sexual energy controlled by a special sub-regulatory mechanism?

The principle of constancy was the basis of the conception of the pleasure/unpleasure principle, but the latter’s complexity (a pleasurable sensation may accompany an increase in tension), became increasingly evident to Freud, reopening the possibility of a confusion of the pleasure and constancy principles. The principle of constancy, which resembles the

principle of homeostasis that Walter Bradford Cannon would later introduce, served as kind of general principle of self-regulation, whereas the specifically sexual pleasure principle can (and must) detract from this general principle. This was an inextricable complexity that the conceptualization, in 1920, of the life drive attempted to resolve.

BERTRAND VICHYN

*See also:* Principles of mental functioning.

### **Bibliography**

- Freud, Sigmund. (1900a). The interpretation of dreams. Part II. *SE*, 5: 339–625.
- . (1920g). Beyond the pleasure principle, *SE*, 18: 1–64.
- . (1950c). Project for a scientific psychology. *SE*, 1: 281–387.
- Laplanche, Jean. (1970). *Vie et mort en psychanalyse*. Paris: Flammarion.
- Laplanche, Jean, and Pontalis, Jean-Bertrand. (1967). *Vocabulaire de psychanalyse*. Paris: Presses Universitaires de France.

---

## **PRINCIPLE OF IDENTITY PRESERVATION**

The principle of identity preservation stipulates that human beings are motivated by the need to preserve and maintain their identity at all costs. Superseding adaptation and the reality principle, the principle of identity preservation governs the psychic apparatus, and the drives are a function of it.

Introduced in 1961 by Heinz Lichtenstein, this principle is the response to what he calls the “dilemma of human identity” in the book of the same title. Human identity is uncertain; the ego cannot guarantee its existence, and the subject must maintain it at all costs. This notion is in keeping with this author’s rejection of the idea of the dualism of the drives.

Human identity is formed through a specific use of nonreproductive sexuality during the dissymmetrical interactions between mother and child—mirroring experiences in which the mother’s seduction triggers an irreversible “identity theme” stemming from the impact of her unconscious messages and the child’s reactions. From this primary, irreversible identity there emerges a sense of the identity of the self, a

creation or variation on an invariant identity theme. Identity formation can suffer disturbances; the existence of impossible “themes”—such as that of nonseparation, which causes an oscillation between solitude and fusion—generates pathological sexual and aggressive manifestations.

The principle of identity preservation underscores the importance of the “preservation of identity” or the self based on the “feeling of identity”—Erik Erikson’s “ego identity.”

The formation of identity makes it possible to resolve Cartesian dualism by forgoing the concept of identification. A metapsychology of the self is established, to the detriment of the drives. Lichtenstein was the first to theorize the notion of identity in the sense of a principle. Robert Stoller used the notion of identity as the theoretical basis for his hypothesis regarding the core of “gender identity” and the inverted gender identity of the feminine boy as stemming from an irreversible early imprint left over from the infant’s symbiosis with the mother. Traces of Lichtenstein’s thought are discernible in Heinz Kohut’s self psychology, although he is not explicitly mentioned: The characteristics attributed to identity by Lichtenstein are close to those of the Kohut’s “Self,” and the principle of identity resembles the same type of conceptualization as the “principal Self” in Kohut’s *The Restoration of the Self* (1977)—the preservation of the Self as fundamental to the psyche.

The importance given to identity—that is, narcissism—in relation to the drives reverses Freudian priorities and presents the risk of a psychoanalysis that is more phenomenological than metapsychological.

AGNÈS OPPENHEIMER

See also: Identity.

### **Bibliography**

- Kohut, Heinz. (1977). *The restoration of the self*. New York: International Universities Press.
- Lichtenstein, Heinz. (1961). Identity and sexuality. In *Dilemma of human identity*. New York: Jason Aronson.

---

## **PRINCIPLE OF (NEURONAL) INERTIA**

The principle of inertia is a principle of the functioning of the nervous system in which the  $\varphi$  neurones

tend to divest themselves completely of the quantities of energy that they receive. Freud presented it at the beginning of the *Project for a Scientific Psychology* (1950c [1895]).

The  $\varphi$  neurones receive external excitations, since they belong to consciousness. These neurones are described as “permeable” because their “contact barriers” (what we today would call synapses) permit quantities of energy to pass toward the, or perceptual, neurones. In the *Project*, Freud takes the general law of motion from physics as his basis, but then focuses on an active tendency of the system, which would oppose the principle of constancy; in effect, he creates a psychophysical fantasy in which it is the working of the system itself—and not the conservation of energy—that is the final goal. The Freudian model here is the reflex arc and, in particular, the “inclination to a flight from pain” caused by an exterior source.

Freud uses the notion of inertia in an ambiguous manner. In the physical sense, it is a property of what he calls “quantity,” which, transformed into “quality,” is retained by the memory belonging to the  $w$  system. The word *Trägheit* itself adds an unexpected element: in German it means both “inertia” and “laziness.” While it may be difficult to think of such an active principle as idle, Freud nonetheless used this ambiguity here to indicate the system’s fundamental tendency to retreat from life’s burdens. Elsewhere in his work Freud did use *Trägheit* to mean “laziness,” speaking of “mental laziness,” “intestinal laziness,” “dreams of laziness,” and so on. Later, influenced by Jung’s term “viscosity of the libido,” Freud used the word to mean “inertia,” particularly as a synonym for “fixation.”

While the “principle of inertia” does not appear again in Freud’s work after the *Project*, he does maintain a permanent equivocation between the different levels “constant,” “low,” and “zero” (1920g; Laplanche, 1970/1976).

Although it may represent a metaphor for free circulation in the unconscious, the principle of inertia can be considered as an eventual source of errors. Beyond its theoretical heir, the nirvana principle/death drive, it cannot account with any specificity for the encounter on the level of libido between adult and child. On the other hand, the principle of neuronal inertia does offer a certain resemblance to the free circulation of thing-representations that characterizes the

unconscious, and it might well describe the results of trauma.

BERTRAND VICHYN

*See also:* Discharge; Facilitation; Primary object; Principle of constancy; Principle of mental functioning; “Project for a Scientific Psychology, A”; Psi ( $\Psi$ ) system; Word-presentation.

### **Bibliography**

Freud, Sigmund. (1920g). Beyond the pleasure principle. *SE*, 18: 1–64.

———. (1950c [1895]). Project for a scientific psychology. *SE*, 1: 281–387.

Laplanche, Jean. (1976). *Life and death in psychoanalysis* (Jeffrey Mehlman, Trans.). Baltimore: Johns Hopkins University Press. (Original work published 1970)

Laplanche, Jean, and Pontalis, Jean-Bertrand. (1974). *The language of psycho-analysis* (Donald Nicholson-Smith, Trans.). New York: W. W. Norton. (Original work published 1967)

---

## **PRINCIPLES OF MENTAL FUNCTIONING**

The term *principles* is used to refer to the fundamental postulates or hypotheses proposed by Sigmund Freud to describe the basic laws of the psyche; they provide the basis for ordering mental functioning as a whole and making it intelligible. The two main principles of the psychic apparatus are the pleasure/unpleasure principle and the reality principle; their dialectical relationship and composition explain the organization of psychic dynamics.

The concept of principle does not appear as such in psychoanalytic metapsychology; it is always articulated together with another notion whose essential and organizing characteristics are determined in accordance with it. Regardless of which principle is involved—the pleasure/unpleasure principle or the reality principle, or, as these are expressed in different forms, the nirvana principle or the principle of constancy (the latter being less conceptually important in the current and historical corpus of the theoretical practice of psychoanalysis)—a principle describes the orientation of the action of the psychic processes, which determines their direction and limits the conditions under which they are put into effect. Principles are thus both explanatory principles used in making

the psyche intelligible, and laws to which the psyche is subjected or must submit.

The first principle to appear in Freudian metapsychology is the unpleasure principle posited in *The Interpretation of Dreams* (1900), which states that the psyche aims to reduce or eliminate sources of tension that result in unpleasure. However, as early as the “Project for a Scientific Psychology” (1895), Freud postulated the existence of a psychic process that also aims to select memory traces of pleasurable experiences.

The pleasure/unpleasure principle as described by Freud in “Formulations on the Two Principles of Mental Functioning” (1911b) has two aspects: on the one hand, to reproduce and re-present to the psyche experiences that have produced pleasure in the past or are likely to produce pleasure in the present; and, on the other hand, to avoid or eliminate experiences that have resulted in unpleasure. This implies a principle of selection that is exercised either through hallucinatory wish-fulfillment, for pleasurable experiences, or through repression, for unpleasurable experiences. However, hallucinatory wish-fulfillment or repression cannot in fact cause intrapsychic tensions to disappear, and an organism limited to the pleasure/unpleasure principle alone could not survive.

Thus, when it goes into effect the pleasure principle encounters what could be called the “reality principle of pleasure”—that is, the principle of an effective reduction of tension that presupposes, at least initially, recourse to an external object. The reality principle thus does not override the pleasure principle; rather, it transforms its mode of expression and action by taking into account the conditions of internal and external reality.

It is the constancy principle that governs the fact that pleasure is no longer attained as a result of an absolute reduction of intrapsychic tensions, but rather through a reduction relative to a certain threshold or constant, and by submission to certain requirements of reality. The nirvana principle, on the other hand, expresses the psyche’s tendency toward an immediate and absolute reduction (to zero) of sources of tension. As can be seen, all of the principles evoked above can be inscribed within the orbit of the principle of pleasure/unpleasure; they are derivatives that integrate, to varying degrees, other characteristics of psychic life into their operations, but without calling into question



the primary and fundamental principle of the orientation of the psyche's action.

In "Beyond the Pleasure Principle" (1920) Freud began to describe processes that seemingly contradicted the pleasure/unpleasure principle. In this essay he emphasized the existence of mental impulses that reactivate experiences that had not produced any conscious or unconscious satisfaction, either at the time or through deferred action (*après-coup*). These exceptions to the pleasure/unpleasure principle are due to the repetition compulsion. In this way, with "Beyond the Pleasure Principle," the pleasure principle appears as a secondary principle; the primary or immediate or fundamental tendency is no longer the avoidance of unpleasure or the search for pleasure, but rather repetition of an earlier state, the tendency to return to an earlier state.

RENÉ ROUSSILLON

*See also:* Act, action; Automatism; *Beyond the Pleasure Principle*; Binding/unbinding of the instincts; Cathartic method; Children's play, the; Conscious processes; Cure; Death instinct (Thanatos); Desexualization; Determinism; Discharge; Dualism; Ego; "The Ego and the Id"; Ego instincts; Erotogenic masochism; Excitation; Fantasy; Fechner, Gustav Theodor; Fort-Da; Free energy/bound energy; Frustration; Fundamental rule; Historical reality; Hypercathexis; "Instincts and Their Vicissitudes"; Judgment of condemnation; Matte-Blanco, Ignacio; Mythology and psychoanalysis; Neurosis; Nirvana principle; Omnipotence, infantile; Pleasure/unpleasure principle; Primary process/secondary process; Principle of constancy; Principle of identity preservation; Principle of (neuronal) inertia; "Project for a Scientific Psychology, A"; Protective shield; Protective shield, breaking through the; Psychic apparatus; Psychic reality; Psychology and psychoanalysis; Purified-pleasure-ego; Quantitative and qualitative; Reality testing; Relaxation principle and neocatharsis; Satisfaction, experience of; Self-preservation; Structuralism and psychoanalysis; Sum of excitation; Thing, the; Unpleasure; Wish, fulfillment of a; Work (as a psychoanalytical notion).

### **Bibliography**

- Freud, Sigmund. (1911b). Formulations on the two principles of mental functioning. *SE*, 12: 218–26.
- . (1920). Beyond the pleasure principle. *SE*, 18: 7–64.
- . (1924). The economic problem of masochism. *SE*, 19: 149–53.

Laplanche, Jean. (1970). *Vie et mort en psychanalyse*. Paris: Flammarion.

Roussillon, René. (1995). *La métapsychologie des processus et la transitionnalité*. (Congrès 55 des Psychanalystes de Langue française des Pays romans. Paris, 1995) *Revue française de Psychanalyse*, 59, 1351–1519.

### **Further Reading**

Modell, Arnold. (2000). Are mental functions hierarchical? *Annual of Psychoanalysis*, 28, 127–136.

---

## **PRIVATION**

The concept of privation is essential for Freud. In *The Future of An Illusion* (1927c), he writes: "For the sake of a uniform terminology we will describe the fact that an instinct cannot be satisfied as a 'frustration,' the regulation by which this frustration is established as a 'prohibition' and the condition which is produced by the prohibition as a 'privation'" (p. 10). Later in the same essay, he defines more specifically the drive-wishes that result from privation: incest, the pleasure in and wish to murder, and cannibalism.

Melanie Klein and Jacques Lacan are the main authors to have taken up this concept. For Klein, privation is the basis for the paranoid position. She writes: "Persecutory anxiety, therefore, enters from the beginning into [the baby's] relation to objects in so far as he is exposed to privations" (Klein, 1932/1952b, p. 199). And elsewhere: "Feelings of frustration and grievance lead to phantasying backwards and often focus in retrospect on the privations suffered in relation to the mother's breast" (Klein, 1952a, p. 265). All feelings of privation or frustration originate in the subject's relationship with the mother, specifically with the maternal breast. These feelings are also articulated with persecution and fragmentation anxieties.

In "L'archaïque et le profond dans la pensée de Melanie Klein" (The Archaic and the Profound in Melanie Klein's Thought; 1982), Jean-Michel Petot discusses the constant slippage between the terms *privation*, *deprivation*, and *frustration* in Klein's work. He clearly shows Klein's difficulties with these notions, as well as the role played by Ernest Jones's translations of the German term *Versagung*.

For Jacques Lacan, archaic persecution or fragmentation anxieties are to be deduced from castration

anxiety and are not its precursors. Privation is what is inscribed in the Real and reveals its nature. Privation corresponds to the “hole” in the Real; it is the basis of the Symbolic Order, and the agent who deprives is always Imaginary. Lacan’s answer to the question concerning what is actually being deprived is that “It is especially the fact that the Woman does not have a penis, that She is deprived of it. [...] The very notion of privation, so tangible and visible in an experience such as that one, implies the symbolization of the object in the real. For in the real, nothing is deprived of anything. Everything that is real is sufficient unto itself. By definition, the real is full [*plein*]. If we introduce the notion of privation into the real, it is to the extent that we can already symbolize it adequately, or even completely. Indicating that something is not there means supposing its possible presence—that is, introducing into the real, in order to recover it and hollow it out, the simple symbolic order” (1956–57).

The reversal effected by Lacan, as compared to authors inspired by Klein, is striking, and it is the basis for his claim of making a rigorous return to Freud. However, his was a return to a particular Freud: In Freudian thought, while woman is indeed deprived of a penis, the male child is just as deprived of the breast. Although woman can aspire to replace what she lacks by bearing a child, man must replace that which he has been deprived of with “spiritual nourishment,” or thought.

LUIZ EDUARDO PRADO DE OLIVEIRA

*See also:* Amnesia; Child analysis; Deprivation; Disintegration, feelings of, (anxieties); Subject’s castration; Feminism and psychoanalysis; Frustration; Forgetting; Primary need; Real, Symbolic, and Imaginary father; Schizophrenia; Weaning; Unary trait.

### **Bibliography**

- Freud, Sigmund. (1927c). The future of an illusion. *SE*, 21: 1–56.
- Klein, Melanie. (1952a). On observing the behaviour of young infants. In Melanie Klein, Paula Heimann, Susan Isaacs, and Joan Rivière (Eds.). *Developments in psychoanalysis* (pp. 237–270). London: Hogarth.
- Klein, Melanie. (1952b). Some theoretical conclusions regarding the emotional life of the infant. In Melanie Klein, Paula Heimann, Susan Isaacs, and Joan Rivière. (Eds.). *Developments in psychoanalysis* (pp. 198–236). London: Hogarth. (Original work published 1932)

Lacan, Jacques. (1956–57). *Le séminaire: Livre IV, La relation d’objet* (pp. 237–270). Paris: Le Seuil.

Petot, Jean-Michel. (1982). L’archaïque et le profond dans la pensée de Melanie Klein. *Nouvelle revue de psychanalyse*, 26, 253–272.

### **Further Reading**

Shengold, Leonard. (1989). *Soul murder: The effects of childhood abuse and deprivation*. New Haven: Yale University Press.

---

## **PROCESS**

The term *process* is used extensively from within different perspectives, not all of which fall within the scope of psychoanalysis. The concept has been defined in the fields of philosophy, psychiatry, psychopathology, and psychoanalysis, with various meanings that, over time, have come to overlap one another, gradually expanding its scope.

Only the salient points of the term’s evolution can be given here. Etymologically, “process” is derived from the Latin *procedere*, which means “to move forward,” and reflects the dynamic aspect of the concept. In philosophy it designates “a succession of phenomena presenting a certain unity or that are reproduced with a certain regularity.” André Lalande notes that the term is often used to refer to physiological, psychological, or social phenomena, and much more rarely to mental phenomena.

In psychiatry, “process” indicates the dynamic and productive nature (of symptoms) of a given state or modality of mental operation. For example, we speak of a process, the psychotic active phase, to indicate that there is a particular evolutionary moment in mental pathology that is considered to give rise, more or less transiently, to the emergence of delusions or hallucinations.

In psychopathology it is the German school of the nineteenth and twentieth centuries—especially Karl Jaspers—that developed the distinction between “process” and “development.” At the time, existential philosophy and phenomenology had completely revitalized conceptions of psychopathology. Consequently, so-called quantitative disturbances (developments) were isolated from qualitative disturbances (processes). The first were associated only with an anomaly in the intensity of certain psychic mechanisms (fears,

inhibitions, rituals), which were relatively easy to understand, while the second implied a disturbance of mental operation that was currently incomprehensible to the outside observer. We can see how, from this point of view, the neuroses would be seen as developments (even though eventually an author like Pierre Marchais would introduce the concept of “neurotic process”) while the psychoses are processes, since they are associated with a break with external reality and the entrance of the suffering subject into a specific representational world.

In psychoanalysis the description of defense mechanisms associated with neurotic and psychotic mechanisms harmonizes fairly well with the above psychopathological viewpoint, since the neurotic subject is here considered as having recourse, in a quantitatively abnormal and rigid manner, to certain specific, but normal, defense mechanisms (repression during hysteria, isolation and retroactive cancellation in the case of obsessive neurosis, displacement in the case of phobias), while the psychotic subject has recourse to defense mechanisms (splitting, denial, projection, idealization) that are qualitatively different than those used by the so-called normal subject. The neurotic subject would thus have lost only the flexible and extensive use of the entire range of defensive mechanisms at the disposal of the normal subject, but the mechanisms used by him would be qualitatively normal (development). The psychotic subject, however, would make use of qualitatively abnormal defensive mechanisms (process).

In reality this approach needs to be modulated to the extent that extensive study of psychotic and archaic processes has shown that the mechanisms in question in this type of psychopathology can also be described at the so-called “primal” levels of mental functioning (Piera Aulagnier), especially in the infant, but prematurely and much too transiently.

It is in the “Project for a Scientific Psychology” that Sigmund Freud lays out for the first time his neuronal theory of primary and secondary processes. The primary process tends to discharge excitations (free energy), while the secondary process provides various means of discharge (bound energy) since it operates at the level of psychic attention and extends to the mechanisms of perception and intelligence: “Wishful cathexis to the point of hallucination [and] complete gratification of unpleasure which involves a complete

expenditure of defence are described by us as *psychical primary processes*; by contrast, those processes which are only made possible by a good cathexis of the ego, and which represent a moderation of the foregoing, are described as *psychical secondary processes*. It will be seen that the necessary precondition of the latter is a correct employment of the *indications of reality*, which is only possible when there is inhibition by the ego” (1950c [1895], pp. 326–327).

Freud would return to this distinction on several occasions in *The Interpretation of Dreams* (1900a), but it was in 1911, when he fully described the two major types of psychic function (unconscious and conscious), that he returned to this distinction. Here he clarifies the differences between primary processes (free energy, pleasure principle), governing our fantasies, neuroses, and “everyday psychopathology,” and secondary processes (bound energy, reality principle), governing the dynamics of rational thought, which is logical and desexualized (1911b).

Subsequently, Freud described positions anterior to and posterior to primary and secondary processes. The anterior processes have been extensively described by Piera Aulagnier, who distinguishes three successive registers that operate together: primal processes (the first level of embodiment of sensory experience by means of “pictograms”), primary processes (staging, staging of fantasies), and secondary processes (“vocalization” of so-called secondary thought experienced from a first-person point of view). The posterior processes have been investigated by André Green, who described “tertiary” processes as modalities of regulation (work of the preconscious) between primary processes and secondary processes or between thing-representations and word-representations.

Throughout these developments, the term “process” remains highly polysemic depending on the epistemological field in which it is used.

BERNARD GOLSE

*See also: Apprenti-historien et le maître-sorcier (L’-)* [The apprentice historian and the master sorcerer]; Conscious processes; Desexualization; Group analysis; Identification; Individual, Individuation (analytical psychology); Integration; Introjection; Jokes; Metapsychology; “Outline of Psychoanalysis, An”; Primal repression; Primary identification; Primary process/secondary process; Reality testing; Thought; *Violence of Interpretation, The: From Pictogram to Statement.*

## Bibliography

- Castoriadis-Aulagnier, Piera. (2001). *The violence of interpretation: From pictogram to statement* (Alan Sheridan, Trans.). East Sussex, UK: Brunner-Routledge.
- Freud, Sigmund. (1900a). The interpretation of dreams. Part I, *SE*, 4: 1–338; Part II, *SE*, 5: 339–625.
- . (1911b). Formulations on the two principles of mental functioning. *SE*, 12: 213–226.
- . (1950c [1895]) Project for a scientific psychology. *SE*, 1: 281–387.
- Green, André. (1972). Note sur les processus tertiaires. *Revue française de Psychanalyse*, 36, 3, 407–410.
- Jaspers, Karl. (1913). *General psychopathology* Manchester Universities Press, 1963.
- Lalande, André. (1926). *Vocabulaire technique et critique de la philosophie*. Paris: Presses Universitaires de France.
- Marchais, Pierre. (1968). *Les processus névrotiques: contribution à l'étude psychopathologique des névroses*. Paris: L'Expansion.

---

## PROCESSES OF DEVELOPMENT

The expression “processes of development” is used to describe all the processes and mechanisms that contribute to differentiating-organizing a living being from the start of life onwards. The result of these processes for any given organism at any given time corresponds to its “level of development.”

The different phenomena involved in development must be considered in terms of the somatic level (morphological growth, development of physiological functions), behavioral level and psychic level, the level of psychogenesis. The work of genetic (or *developmental*) psychology is defined in terms of this last level, but an essential aspect of psychoanalytic theory and clinical practice is also situated at this level.

Freud's interest in the processes of development appeared in his first scientific works, well before he created psychoanalysis. In an attempt to establish the pathways of nerve conduction he tried to grasp their development through comparative anatomical studies of fetuses. From the very beginning he thus posited a principle that he was to use in creating psychoanalysis itself: in order to understand a complex structure in an adult, the sovereign method is to grasp the successive stages in its construction. Moreover, as an ardent

Darwinian, he straightaway and ever after considered time as an essential part of the data.

The reason he became so excited by Josef Breuer's account of the case of Anna O. in 1885 was because he saw it as proof that when subjects themselves go back in time through their own history, this has a curative effect. The cases reported in *Studies on Hysteria* (1895d) are all built around this principle, as is the accompanying theoretical writing.

He thought he had found the psychopathological equivalent of the source of the Nile: every case of psychoneurosis, particularly hysteria, can be considered as a progressively constituted formation based on a traumatic incident in childhood, an incident that is always of a sexual nature and whose effect is deferred, not appearing until the subject reaches puberty. He nevertheless came to doubt that “seduction” of girls by their fathers was as frequent as the hysterics he treated would have had him believe. After a brief period of discouragement (“*they are only fantasies*”), he effected a remarkable recovery (“*they are fantasies*” that the patient places in the past and which must be analyzed). The analysis of the case of Little Hans in 1905 (the text was not published until 1909) offered him a live study of the development of such fantasies in the child, as well as their pathogenic effects.

This *developmental* point of view was to continue to have major importance in Freudian thought. He thus wrote his *Formulations on the Two Principles of Mental Functioning* (1911b) in the imperfect tense, as if he were telling a story. In 1913 he wrote that the psychoanalytic approach “consists in relating a psychic formation to others preceding it in time and from which it has developed [...] from the very beginning psychoanalysis has been led to look for processes of development” (1913i).

Freud had to have recourse to a general theory of development in order to account for mental pathologies: they were deviations from the normal pathways, fixations at any given stage that should have been surpassed, regressions to earlier formations, the whole culminating in repetitive, rigid, and irritating structures. It was in these terms that he analyzed the case of the Wolf Man. It was indeed, as its title indicates (*From the History of an Infantile Neurosis*), by reconstructing the past that he explained the pathology of the adult (text written essentially in 1914, was published in 1918).

In 1915, Freud wrote *Overview of the Transference Neurosis* (1985a) in a state of feverish agitation. He was trying to establish correspondences between three histories: the history of the succession of stages in normal psychogenesis; then, more hypothetically, the history of the layering of the psychoneuroses and neuroses (depending on the time of the fixation) in the course of those stages and, even more hypothetically, the history of the stages he refers to as being “phylogenic” in the course of the history of humanity (Perron, 1994). In doing so he based his reasoning, as he had already done on several occasions (particularly in *Totem and Taboo*, 1912–13a), on Ernst Haeckel’s hypothesis, “ontogeny recapitulates phylogeny.”

He finally developed a general theory of psychogenesis wherein the stages are considered to be “developmental phases” (today we prefer to speak of “modes of organization”) that are characterized by the primacy of an erogenous zone and an object-based mode of relation: the oral, anal, phallic stages and adult genital organization (Brusset, 1992).

Having formulated his second topography and his second theory of the instincts (1920–23), Freud devoted more time to structural considerations and allowed synchronic aspects to outweigh diachronic aspects. Others nevertheless devoted themselves to developing a direct approach to children and the psychoanalytic treatment of children. The pioneers, his daughter Anna Freud and Melanie Klein, took quite different stances on practical and theoretical questions, so much so that their opposing positions shook the foundations of the British Psychoanalytic Society.

Since then an important trend in research, supported by extensive experience of analyzing children, has stressed the pregenital phases of development and the processes of the first individuation, with direct observation of the baby and the interactions between the mother and baby (J. Bowlby, R. Spitz, D. W. Winnicott, D. Stern, B. Cramer, S. Lebovici), but also with regard to the serious alterations we find in cases of infantile autism and psychoses (M. Mahler, M. Klein, F. Tustin, D. Miltzer, R. Diatkine). It is worth observing that infant and child psychiatry owes a large part of its remarkable development over the last thirty years to psychoanalysts.

The developmental perspective in psychoanalysis calls for a certain number of comments:

- a. As we have seen, Freud was the first to try to go back through personal history to undo a fixation point; in order, according to a metaphor that was dear to him, to deconstruct a unit and then reconstruct it with a better balance from the vestiges thus revealed. He went on to considerably modify these oversimplistic views, admitting that traces of the past do not exist as such but are constantly remodeled retroactively.
- b. In which case, what history is in question (Le Beuf, Perron, Pragier, 1997)? Analysts cannot limit themselves to working on *factual* history, the history that any careful anamnestic investigation would reveal. The analyst’s only informant is the patient and the history he or she recounts is made up as much of fantasies as it is of memories of events whose reality is unverifiable; it is largely constructed retroactively and most of the materials are consigned to the unconscious (Viderman, 1970). In fact the history that the analyst is trying to reconstitute is the *psychic* history of the subject as revealed by the functioning of the subject’s mind. It may be very different from a “real” history as told step by step.
- c. But how is it grasped? *Direct observation* of the baby, which is supposed to provide first-hand objective material is far from being as conclusive as it might appear: the data has no meaning except when interpreted in the light of the psychoanalytic theory it is supposed to support.
- d. From a theoretical point of view, psychoanalysis was shaken by the great controversy on “structure or history?” which began to spread during the seventies from linguistics to all human sciences. We have seen and continue to see in this context the opposition between those who give pride of place to individual history (in currents as diverse as Hartmanian Ego-Psychology and the Kleinian school) and those who reserve it for structure (particularly Lacan and those who followed him).

ROGER PERRON

*See also:* Anthropology and psychoanalysis; Change; “Claims of Psychoanalysis to Scientific Interest”; Developmental disorders; Fixation; Individual; Infant development; Infant observation (direct); Maturation; Ontogenesis; Phylogenesis; Process.

## Bibliography

Brusset, Bernard. (1992). *Le développement libidinal*. Paris: Presses Universitaires de France.

Le Beuf, Diane, Perron, Roger, and Pragier, Georges (Eds.). (1997). *Construire l'histoire*. Paris: Presses Universitaires de France. Monographies de la *Revue française de Psychanalyse*.

Perron, Roger. (1994). *Une fiction préhistorique de Freud*. In A. Fine, R. Perron, F. Sacco (Eds.), *Psychanalyse et préhistoire*. Paris: Presses Universitaires de France.

———. (1995). Prendre pour vrai. *Revue française de Psychanalyse*, 59, 2, 499–512.

———. (1995). Théories de la psychogenèse. In *Encyclopédie médico-chirurgicale*. Vol. *Psychiatrie*. Paris: E.M.-C., fasc. 37-810-F-30.

Viderman, Serge. (1970). *La construction de l'espace analytique*. Paris: Denoël.

## Further Reading

Tyson, Phyllis, and Tyson, Robert. (1990). *Psychoanalytic theories of development: An integration*. New Haven; London: Yale University Press.

Tyson, Phyllis. (2002). The challenges of psychoanalytic developmental theory. *Journal of the American Psychoanalytic Association*, 50, 19–52.

## PROGRESSIVE NEUTRALIZATION

In 1963 Heinz Kohut and Philip Seitz proposed an alteration in Sigmund Freud's diagrammatic structural model of the mind (1923). In their revised model (see Figure 1), they expanded the diagram to include the unrepressed unconscious activities and infantile impulses in interrupted contact with the preconscious layers of the surface. They called this the "area of progressive neutralization." It is formed through the pro-

**FIGURE 1**

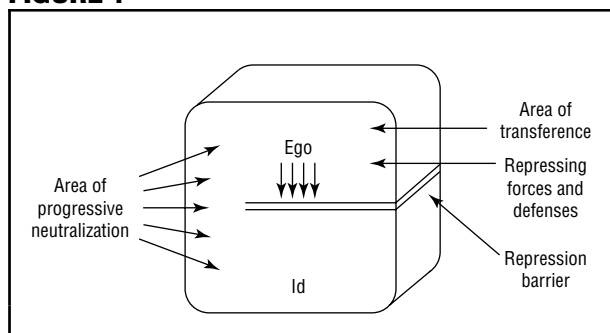

cess of transmuting internalization and consists of a drive restraining or neutralizing structure.

ARNOLD GOLDBERG

See also: Transmuting internalization.

## Bibliography

Kohut, Heinz, and Seitz, Philip. (1963). Concepts and theories of psychoanalysis. In Joseph M. Wepman and Ralph W. Heine (Eds.), *Concepts of personality* (pp. 113–141). Chicago: Aldine Press.

## PROHIBITION

The term *prohibition* has been borrowed by psychoanalysis from everyday language, where it is used either as an adjective to describe something we are not allowed to do, say, see, think, or be; or substantively to refer to the law, social constraint, moral education, and so on, on which this prohibition is based.

Psychoanalytic language gives a more precise meaning to the term, however. Prohibition can present itself to the subject as external, and be internalized as a result of its associated dynamic of conflict; it can also result from structural requirements inherent in the mind. In every case the formulation of the prohibition and its operation can be partially or totally unconscious, even when the resulting conduct and its justification are explicit.

The concept appears early in Freud's work and can be found in the *Studies on Hysteria* (1895d), where the subject, driven by desires prohibited by morality, consciously forms "representations that are irreconcilable" with that morality, and then refuses them satisfaction, doing away with them by making them unconscious through repression. Those desires are always, in the final analysis, sexual in nature, especially in the case of the "neuro-psychoses of defense." "The etiology of hysteria almost inevitably can be traced to a psychic conflict, an irreconcilable representation, which prompts into action the defense of the ego and provokes repression" (Freud, 1896b). From the very outset, then, the notion of prohibition is inseparable from the drive-defense conflict, which will constitute the core of psychoanalytic theory.

Initially, that is to say, within the framework of the first topography and the first theory of drives, Freud studied the libidinal origins of the conflict and its treatment through repression (these are the texts on metapsychology from 1915) as well as its educational

(“Little Hans,” 1915), sociological and ethnological (*Totem and Taboo*, 1912–1913a) origins. The formulation of the Oedipus complex then focused attention on the prohibition of incest.

Subsequently, the formulation of the second topography led to a redefinition of prohibition. Here, the ego appears as prey to conflicts where it is torn between “three masters”: the id and its libidinal demands, reality and adaptive requirements, and a superego that is essentially defined as an agent of prohibition. (However, to this must be added the more positive functions of the ego ideal, which condenses all the moral values the subject claims to hold.)

Although throughout his work Freud presents the incest prohibition as the heart of the conflictual dynamic, he also discusses prohibitions that affect other manifestations of sexuality, primarily masturbation and the satisfaction of the partial drives or compound instincts (voyeurism, exhibitionism, anal pleasure). Generalization of the limitations created by these prohibitions can lead to serious inhibitions of thought. Moreover, it has been shown how the repression of the drives can lead to serious reaction formations, especially when aggression is poorly integrated.

ROGER PERRON

*See also:* Censorship; Conflict; Deprivation; Ethics; Incest; Law of the father; Oedipus complex; Taboo; Transgression.

### **Bibliography**

Freud, Sigmund. (1896b). Further remarks on the neuro-psychoses of defence. *SE*, 3: 157–185.

Freud Sigmund, and Breuer, Josef. (1895d). Studies on hysteria. *SE*, 2: 48–106.

Mijolla-Mellor, Sophie de. (1993). Le “bon droit” du criminel. *Topique*, 52, 141–161.

Milner, Marion. (1991). *On est prié de fermer les yeux. Le regard interdit*. Paris: Gallimard.

---

## **“PROJECT FOR A SCIENTIFIC PSYCHOLOGY, A”**

The “Project for a Scientific Psychology”—a title provided by the editors upon the manuscript’s first publication in 1950—is part of Freud’s correspondence with Wilhelm Fliess. Freud himself referred to it as

“Psychology for Neurologists,” or else as “ $\phi \psi \omega$ ” (his denominations for the three kinds of neurones described in the text). His two aims in this piece were to arrive at “a sort of economics of nerve forces” and “to peel off from psychopathology a gain for normal psychology” (Freud to Fliess, May 25, 1895, 1985c, p. 129).

Freud’s “Project” was first conceived in late March, 1895. In September, returning from a visit to Fliess in Berlin, where the two discussed it, he began the writing while still on the train, and on October 8, he sent Fliess two notebooks, holding back a third dealing with repression. These were followed by his letter to Fliess of January 1, 1896 and the attached “Draft K.” Even at this time Freud oscillated between feeling that the work we know as the “Project” was “delusional” and feeling that it was an excellent start on “the elucidation of the neuroses”; and if the “quantitative conception” would in fact never disappear from his work, it would always remain in the background.

The first part of the “Project” is devoted to the description of physical prototypes of repression. The model of the organism here seems to be the vesicle exposed to the very powerful energies of the “primal soup.” When flight is not available to the system, it resorts to its multiple protective survival mechanisms. Thus Freud begins his discussion by introducing the “principle of inertia” and then proceeds to describe two systems of neurones,  $\phi$  and  $\psi$ , soon to be joined by a third,  $\omega$ , concerned with perception. Presentation of the notion of “contact-barriers” gives him an opportunity to point up the distinction between perception and memory by which he would always subsequently abide (1925a).

To protect itself, the system is said to rely not only on the principle of inertia but also on “quantity-screens” constituted by “nerve-ending apparatuses” as a way of guaranteeing a first bulwark against the powerful stimuli of the outside world (*SE I*, p. 306). The outcome of a failure in this protective contrivance is pain, along with the intrusion of excessive quantities of excitation that “leave permanent facilitations behind” (p. 307). Consciousness, meanwhile, is defined by Freud as the locus of transformation of “quantity” into “quality” in the “x” system of neurones (p. 311). This is the context in which the “pleasure/unpleasure principle” is first framed in terms, here, of proportional fullness (analogous, arguably, to hunger’s proportionality to lack in the case of the

alimentary function): an excessive cathexis of neurones, according to Freud, generates unpleasure, while a lesser cathexis thereof gives rise to pleasure (p. 312).

After recapitulating “the functioning of the apparatus,” Freud goes on to describe the  $\Psi$ -system of neurones as exposed without protection to the quantity of endogenous stimuli, “and in this fact lies the *mainspring* [*Triebfeder*] of the psychical mechanism” (pp. 315–16). This first adumbration of the instinct or drive (*Trieb*) is followed in the “Project” by a discussion of the “experience of satisfaction”—a reaction to the “filling” (“*Erfüllung*,” which also means “fulfillment”) of the neurone by a pressure or urgency that results in a motor discharge, as for example screams. Being incapable of feeding itself, the infant succeeds in this way in calling up “extraneous help” (p. 318)—or in other words an adult, who satisfies the need for nourishment and subsequently becomes a “memory of the object” whose image may, should the need arise once again, be hallucinated (p. 319).

Having thus linked the vital and sexual spheres, in counterpoint to satisfaction, Freud turns to the “experience of pain,” in which the system perceives a “hostile object” (is Freud thinking of two distinct objects or of a single object “split” into “good and “bad”?) behind which we may discern the “seducer,” the idea of which (or of whom) gives rise to an increase in the level of excitation, and hence of unpleasure (p. 320). The organization of the apparatus is thereafter perfected thanks to the development of the “ego.” The ego is supposed to inhibit the system and to mobilize secondary against primary processes. This new way of functioning allows for the emergence of “indications of reality” (p. 325), of the capacities for judgment, remembering, thought, and so on. Freud returns to the issue of the primary process at the end of this ontogenetic itinerary, considering its role in sleep and dreams, which constitute a return to an earlier state and permit the “fulfillment”—comparable to the aforementioned “filling” of neurones—of “wishes.”

A description of the play of displacements, ideas, and quantities in dreaming provides Freud with an easy transition to the second, and unfortunately the shortest part of the “Project,” entitled “Psychopathology.” Here he explains “hysterical compulsion” by means of a very interesting theory of the symbol.

Whereas the displacements and substitutions that give rise to “symbols” in normal subjects are said to be the same in hysterics, in the case of hysterics, “The symbol has in this case taken the place of the *thing* [that has been repressed] entirely” (p. 349). The two preconditions of repression coming into play, Freud asserts, are that the idea affected be unpleasurable and that it be sexual (p. 350). But “the core of the riddle” of repression remains, for, in contrast with hysteria, “compulsive neurosis” can arise without symbol-formation (p. 352). Thus the “*proton pseudos*” is constituted by two premature scenes of a sexual nature whose impact is “deferred” until quantities of sexual excitation are released at puberty. The ego is then evaded by memories while it is preoccupied with defending itself against assaults coming from perception. The specific action of sexuality can be explained only by reference to its belatedness as compared with the rest of the individual’s development: “The retardation of puberty makes possible posthumous primary processes” (pp. 356, 359).

The third part of the “Project” is a long presentation of normal mental processes, in which Freud seeks to situate issues of general psychology—attention, judgment, thought, memory in relation to language, and so on—within the framework that he has been developing. One interesting idea is that the pleasure principle might be an inhibiting mechanism that pushes the ego to learn attentiveness and to cathect the wishful idea to a moderate degree (p. 361). In the later development of his work, Freud would make these considerations the basis of the reality principle, even though he would characteristically, given his predilection for over-rigorous oppositions, treat this as an absolute antagonist of the pleasure principle. His discussion here of “observing thought” (pp. 363–65), meanwhile, though it might seem off-putting, may well have led him to develop the technique of “free association.”

A final aspect of the “Project” that needs stressing is, according to James Strachey (*SE 1*, p. 291), the remarkable part played by sexuality in this early work. Freud was indeed rather too prone, later, to forget what he had described here as a cardinal aspect of repression—the fact that it affects only *sexual* ideas (p. 352); and he likewise paid insufficient attention to the impossibility for the child of metabolizing adult sexuality, of handling what in the “Project” are called “excessively intense” (*überstark*)



ideas (p. 347). Simultaneously indicated and masked by the metaphorization of the general development of the mental apparatus, this embryonic account of the advent of a sexual “program” in the child is presented solely from the point of view of the “receiver” and offers no parallel description of the “transmitter,” which would have introduced the interpersonal dimension. Precisely because of this omission, Freud would tend to espouse the idea of inborn sexual programming, in which context the primary process became proof of the unconscious as opposed to what it might have been if the view of the “Project” had been followed, namely a receiving area for an unconscious brought into being for its part by multiple encounters with the objects of childhood.

First published in 1950 in the original German, translated into English in 1954, the “Project” was greeted with enthusiasm by Freud’s admirers. A whole generation of physicians thought it promoted a new rapprochement between two forms of knowledge (medicine and psychoanalysis) that history had tended to set at odds. James Strachey, however, had already cautioned against an excessive reaction to the “Project’s” disinterment (*SE*, 1, p. 239). Today the enthusiasm has been much tempered, especially among “biologists,” who argue that what seemed like brilliant insights when the “Project” emerged have been much tarnished by the passage of time. All the same, for psychoanalytic researchers this work is still a cornucopia of discoveries yet to be made and of avenues past and future to be avoided.

BERTRAND VICHYN

*See also:* Attention; Cathexis; Deferred action; Ego; Hypercathexis; Incompleteness; *Interpretation of Dreams, The*; Mnemic trace/memory trace; Perception-Consciousness (Pcpt.-Cs.); Perceptual identity; Physical pain/psychic pain; Pleasure/unpleasure principle; Primary process/secondary process; Protective shield; Proton-pseudos; Psi system; Psychic causality; Psychic energy; Psychology and psychoanalysis; Quantitative/qualitative; Specific action; Sum of excitation; Symbol; Wish, hallucinatory satisfaction of a; Word-presentation.

### Source Citation

Freud, Sigmund. (1950c [1895]). Entwurf einer Psychologie. In Marie Bonaparte, Anna Freud, and Ernst Kris, (Eds.), (1950a). *Aus den anfangen der psychoanalyse. briefe an Wil-*

*helm Fliess, abhandlungen und notizen aus de jahren 1887–1902*. London: Imago; *GW, Nachtragsband*, 387–477; corrected transcription in J. M. Masson and Michael Schröter, (Eds.), *Briefe an Wilhelm Fliess, 1887–1904*, Frankfurt am Main: Fischer, 1986; Marie Bonaparte, Anna Freud, and Ernst Kris, (Eds.), *The origins of psycho-analysis: Letters to Wilhelm Fliess, drafts and notes, 1887–1902*, (James Strachey, Trans.), London: Imago, 1954: 347–445; A project for a scientific psychology. *SE*, 1: 283–387.

### Bibliography

- Andersson, Ola. (1962). *Studies in the prehistory of psycho-analysis*. Stockholm: Svenska Bokförlaget.
- Freud, Sigmund. (1925a). A note upon the “mystic writing-pad.” *SE*, 19: 225–232.
- . (1985c). *The complete letters of Sigmund Freud to Wilhelm Fliess, 1887–1904*. (Jeffrey Moussaieff Masson, Ed. and Trans.). Cambridge, MA, and London: Belknap Press of Harvard University Press.
- Pribram, Karl H., and Gill, Merton M. (1976). *Freud’s “project” reassessed*. London: Hutchinson.

## PROJECTION

In a general sense, the term *projection* refers to the displacement of something from one space to another, or from one part of a single space to another (the Latin word *projectio* translates as “throw forward”). More specifically, this term denotes an operation that consists of transporting a form, or certain elements of that form, onto a receptive support that may be real (as is the case with cinematographic projection) or imaginary (as is the case in projective geometry—for example, the projection of a cube onto a plane, which presupposes laws of transformation). Thus, the concept always involves a distinction between two spaces—the space of origin and the space of destination—that are complementarily defined by this very operation.

This basic definition is found in the psychoanalytic notion of projection, whose specifics raise difficult problems with regard to the two spaces thus distinguished, their distinction, and their complementarity. The spaces in question are known, following Sigmund Freud, as the space of mental reality and the space of the reality of the outside world, that is, internal and external reality.

From a psychoanalytic viewpoint, projection is an intrapsychic process that creates or shapes a percep-

tion (or a collection of perceptions) with reference to an object in the outside world, which, although the subject believes he or she is perceiving it “objectively,” is actually being perceived according to the subject’s own characteristics; the most interesting case is when this object is a real person (sometimes called an *external object*). Passing through all possible intermediary cases, this ranges from cases where the perception is entirely invented, in the absence of any concomitant sensory reference (as in hallucinations, but also nighttime dreams), to cases involving the subject’s “coloration” of an otherwise objective perception (for example, an unknown person’s attitude is perceived as being vaguely hostile by one person, while another perceives it as being fairly friendly).

Freud did not write any text specifically on this notion, although it seems he wrote such a draft in 1915, in the framework of his metapsychological writings of this period. In fact, the idea of projection was already well established in his work. It appeared, still in a very simple form, as early as “On the Grounds for Detaching a Particular Syndrome from Neurasthenia under the Description ‘Anxiety Neurosis’” (1895b [1894]): In anxiety neurosis, the psyche, to protect itself from excessive excitation, “behaves as though it were projecting that excitation outwards” (p. 112). What is described is thus a cathartic evacuation of an overflow of excitation. But it is in a letter to Wilhelm Fliess dated January 24, 1895 (Manuscript H) that the first version of what Freud would subsequently develop under the term *projection* is found. No longer is it merely this evacuation that is involved, but also the transposition outward toward an exterior support, of representations and affects that are linked to it. Freud defined this process as being characteristic of the paranoid subject: “[T]he purpose of paranoia is thus to fend off an idea that is incompatible with the ego, by projecting its substance onto the external world” (p. 209).

Freud returned several times to the problems raised by the notion of projection, in particular in his “Further Remarks on the Neuro-Psychoses of Defence” (1896b) and, later, in “Totem and Taboo” (1912–1913a). Above all, this notion took on a very special importance in his discussion of his case of Judge Daniel Schreber in “Psycho-Analytical notes on an Autobiographical Account of a Case of Paranoia (Dementia Paranoides)” (1911c [1910]).

From the outset, Freud distinguished two clearly distinct mechanisms in this regard. One corresponds to “normal” projection, defined by the following passage from “Totem and Taboo”: “Under conditions whose nature has not yet been sufficiently established, internal perceptions of emotional and thought processes can be projected outwards in the same way as sense perceptions; they are thus employed for building up the external world, although they should by rights remain part of the *internal world*” (p. 64). Thus, this “normal” projection is a component of perception itself and of construction of the real.

The other mechanism involves a “pathological” projection in which the process gets carried away, so to speak, and results in a construction of the real that is so distorted that mental functioning can indeed be considered pathological. This is seen in the phobias, as Freud noted on several occasions, notably in “Instincts and Their Vicissitudes” (1915c). But it is above all the workings of projection in the paranoiac, analyzed in connection with the Schreber case, that best illustrate this mechanism. Schreber’s initial, homosexual position, as constructed by Freud, is essentially: “I (a man) *love him* (a man)” (1911c, p. 63); but this basic proposition, actively combated, undergoes a double transformation that is in fact a double reversal. The inversion of subject/object and active/passive (it is not I who love him; it is he who loves me) and inversion of love/hate (I do not love him; I hate him) culminate in a justification: “I *hate* him because HE PERSECUTES ME” (p. 63). For Freud, Schreber’s entire delusion was constructed on the basis of this mechanism, which could be seen to involve denial, and, more generally, the figures of the negative, the workings of which have been thoroughly analyzed by André Green.

Several major problems arise at this point. The notion necessarily presupposes a distinction between “inside” (the intrapsychic) and “outside” (the outside world). Freud pointed out in “Instincts and Their Vicissitudes” that this distinction is fundamental and necessary from the very beginnings of biological life: The single-celled organism, for example the paramecium, constitutes a functional unit separated from its environment by a membrane; it must import from the environment the nutrients it needs and export the toxic metabolic by-products it produces. This dual, import/export movement, which, in biological terms, involves incorporation/excorporation, is extended and transposed to the level of mental functioning in the

form of introjection/projection. Freud in effect deemed it necessary to define introjection—a notion he borrowed from Sándor Ferenczi—as the necessary complement of projection. Thus, he wrote in this essay: “In so far as the objects which are presented to [the ego] are sources of pleasure, it takes them into itself, ‘introjects’ them . . . and, on the other hand, it expels whatever within itself becomes a cause of unpleasure” (p. 136).

From that point, we are led to consider the processes of identification, which have been defined, precisely, in terms of the pair introjection/projection. But if one goes back to the biological model, one observes that the paramecium, taking from its environment the substances it needs, runs the risk of reimporting the harmful metabolites that it itself has rejected. Similarly, the mind runs the risk of reincorporating from the outside the “bad” elements with which it has, in a sense, polluted it. The fantasmatic aspects of this dialectic between good and bad, in this continual coming-and-going between inside and outside, were in particular developed by Melanie Klein and her followers, based on this fundamental biological schema and within the perspective of Freud’s second theory of the instincts; the notion of projective identification developed by these authors becomes easier to understand in light of these considerations.

To what extent does this dual, inside/outside movement blur or, on the contrary, confirm, the boundaries between psychic reality perceived as such by the subject himself, and the surrounding world, conceived of as existing as a function of its own existence, beyond any omnipotence of thought? The question is clearly raised in the case of dreams, and more generally, that of the hallucinatory satisfaction of desire of which nighttime dreams are a particular case. Generally, day-dreams or reveries maintain a clear distinction between the two, and this is the source of the richness of the imaginary developments in the “transitional space” whose importance was so clearly shown by Donald Winnicott: Here the world is transformed, even created, by psychic reality, but by a psychic reality that is aware of this creative free play. Nighttime dreams thus involve a hallucination through which psychic reality creates illusory perceptions out of whole cloth, in the sense that they do not correspond to any “objective” sensory data. Is it possible, then, following the distinction that Freud consistently sought to maintain, to speak of “pathological” projection?

The question arises even more crucially in the case of the hallucinatory satisfaction of desire in the infant, whose disappointment, according to Freud, presides over the birth of the earliest representations, defined, precisely, by the feeling, “This is inside Me, and not currently and really outside of Me.” Clearly, in no case can such a foundational process of psychic life itself be considered “pathological.”

We are thus led to distinguish two different functions for projection, which, moreover, exist in tight complementarity. On the one hand, a defensive function that involves expelling from the intrapsychic space that which is unpleasurable, threatening, and so forth. On the other hand, an elaborative function in which this expulsion establishes and consolidates the indispensable inside/outside differentiation. From there, many different balances between the two modes of functioning can be established. If the defensive function predominates, projection occurs in the service of misapprehension, and the world thus constructed is inhabited by hostile figures: This is what Freud termed “pathological” projection, from its relatively minor operations in neurotics to the delusional constructions of psychosis. If the elaborative function predominates, this involves, through the extension of the earliest processes of individuation, maintaining and affirming a complementarity between the ego and what is given to it to know.

The notion of projection is among those, which, after Freud, underwent interesting further elaboration, in particular in the British School, in the work of Klein and her successors, with the related notion of projective identification. Wilfred Bion, in particular, distinguished between an excessive form of projective identification that serves the pleasure principle, and which essentially corresponds to what Klein was describing, and a “realistic” projective identification, a primitive mode of communication that serves the reality principle. The latter no longer involves fleeing reality but rather modifying it in order to be able to reintegrate bad projection without being harmed and to better accommodate introjection of good objects.

ROGER PERRON

*See also:* Externalization-internalization; Introjection.

### Bibliography

- Freud, Sigmund. (1895b [1894]). On the grounds for detaching a particular syndrome from neurasthenia under the description “anxiety neurosis.” *SE*, 3: 85–115.
- . (1896). Further remarks on the neuro-psychoses of defence. *SE*, 3: 157–185.
- . (1911c [1910]). Psycho-analytic notes on an autobiographical account of a case of paranoia (dementia paranoides). *SE*, 12: 1–28.
- . (1912–1913a). Totem and taboo. *SE*, 13: 1–161.
- . (1915c). Instincts and their vicissitudes. *SE*, 14: 109–140.
- . (1950a [1887–1902]). Extracts from the Fliess papers. *SE*, 1: 173–280.
- Green, André. (1987). *On private madness*. Guilford, CT: International Universities Press.
- Sami, Ali M. (1970). *De la projection. Une étude psychanalytique*. Paris: Payot.

### Further Reading

- Feldman, Michael. (1994). Projective identification in fantasy and enactment. *Psychoanalytical Inquiry*, 14, 423–440.
- Loewald, Hans W. (1988). In search of nature: Metapsychology, metaphysics, projection. *Annual of Psychoanalysis*, 16, 49–54.
- Sandler, Joseph (Ed.). (1986). *Projection, identification, projective identification*. Madison, CT: International Universities Press.
- Scharff, Jill S. (1992). *Projective and introjective identification and the use of the therapist's self*. Northvale, NJ: Jason Aronson.

---

## PROJECTION AND “PARTICIPATION MYSTIQUE” (ANALYTICAL PSYCHOLOGY)

Carl Gustav Jung defined projection as an initial objectified representation of the contents of the unconscious beyond the states of so-called “*participation mystique*” (mystical participation) and “archaic identity,” and he showed how the individual can be led to see through the illusions of projection and yet, at the same time, to experience symbolic life.

As early as his psychiatric studies written between 1900 and 1908, and also in his thesis, “Psychology and Pathology of So-Called Occult Phenomena,” which he

defended in 1902, Jung was investigating the internal coherence and meaning of representational systems that were largely being ignored by his contemporaries. His conception of “highly charged emotional complexes” (*gefühlbetonte Komplexe*) and his contact with Sigmund Freud led him to analyze, in his “Psychology of the Unconscious. A Study of the Transformation and Symbolism of the Libido. A Contribution to the History of Thought” (1911–1912), the poems and fantasies of a young woman by comparing them to a whole series of myths and rites that stage the difficult process of detachment from one’s original attachments and inclusions. Jung’s subsequent elaboration of his theory of projection was based on the analysis of states of *participation mystique* (he borrowed this French expression from the anthropologist Lucien Lévy-Bruhl) or “archaic identity.”

In the states of *participation mystique* and archaic identity there is no differentiation between object and subject and no distinction between lived experience and what the subject believes he or she perceives about the world. However, projection, which is more specific, enables the subject to apprehend and potentially recognize contents that are still unconscious. Thus, analysis of the religions of our ancestors, the literature and iconography of alchemy and, more generally, the arts, as well as the fantasmatic universe of a given group or individual from the perspective of modern psychology can be quite valuable.

In fact, the Jungian Shadow, Anima, Animus, and Self, before being recognized as presences or inner agencies, are ordinarily projected onto typical figures or acquaintances of the subject, in the same way as they are projected onto the analyst in the transference relationship. The recognition and withdrawal of projections usually provokes a state of disenchantment or, conversely, elation and inflation of the ego; however, these processes can also open the way to a practice of the symbolic life and of human relations without too much alienation or mystification, especially through the experience and analysis of the transference.

Some feared that Jung was indulging himself in an imaginary universe without concrete support. However, his analyses of the history of our culture, his position with regard to various religions and also within the history of psychoanalysis, and above all his ways of conceiving and eliciting the work of the unconscious, not only in its compensatory effects but also its effects of contradiction, give the clinical

practitioner the means of avoiding this potential trap.

CHRISTIAN GAILLARD

*See also:* Transference (analytical psychology).

### **Bibliography**

- Gaillard, Christian. (1995). *Jung*. Paris: Presses Universitaires de France.
- Humbert, Élie Georges. (1988). *C. G. Jung: The fundamentals of theory and practice*. (Ronald G. Jalbert, Trans.). Wilmette, IL: Chiron. (Original work published 1983)
- Jung, Carl Gustav. (1946). The psychology of the transference. *Coll. works* (Vol. 8). London: Routledge and Kegan Paul.
- Samuels, Andrew. (1986). A critical dictionary of Jungian analysis. London: Routledge.

## **PROJECTIVE IDENTIFICATION**

In the paranoid-schizoid position described by Melanie Klein, the ego may split off intolerable experiences by dividing itself, and locating parts of the self in external objects. Typically, though not always, it is “bad” parts of the self which are expelled in this way, but they are then feared as “bad” objects. This process is called projective identification.

The term is first used in a footnote added in 1952 to Klein’s paper on schizoid mechanisms (1946/1952). The concept of projective identification arose from psychoanalytic treatments that she and certain colleagues were conducting with seriously disturbed schizoid and schizophrenic patients (Scott, 1946; Rosenfeld, 1950; Segal, 1950).

Klein described states of vagueness, blankness, apathy, and futility as a result of the mind being split up and parts of it annihilated. She distinguished splitting of the ego from the way repression may remove a word or memory from consciousness, typically in the parapraxes. Frequently she noted that something of what the patient has lost is still experienced by the patient, but as attributed to some external object, perhaps in the analyst. In that sense, a piece of the subject’s personal identity has been projected into someone else’s. She linked this self-directed annihilation of parts of the mind to the death instinct, and viewed it as clinical evidence of the death instinct in, for exam-

ple, the common schizoid experience of feeling that parts of the mind are missing. The associated form of projection very specifically interferes with the sense of self and identity.

As an expulsive process, unwanted bad objects are expelled in an anal phantasy; however, annihilated fragments of the self are also caught up in the expulsion. The result in phantasy is a complex situation in which the parts of the self give a special quality to the object into which these bad things are physically evacuated (the “lavatory mother”). The object retains a special reference to the self, and is not properly distinguished from the self. It is felt to *be* the bad self, and that means the self that is engaged in attacking itself. Projective identification is, therefore, characteristically the process by which the death instinct is split and displaced by projection into the external world. Klein regarded it as the prototype of the aggressive objective-relationship.

The term has been the focus of great attention in the years since it was first described clinically in psychotic patients. It has also been expanded considerably in meaning. Two features have been greatly investigated: firstly its interpersonal aspect; and secondly its normal occurrence in mild form in everyday life.

Not long after Klein’s description of this mechanism, it was realized that in the *interpersonal* dimension the patient re-finds that part of himself in another person. A process occurs in the object (introjection) in which their intrapsychic world actually takes on those aspects the patient has disowned. Then the relationship with the other person conforms to the phantasy that underlies projective identification. In the psychoanalytic setting this interaction between two intrapsychic worlds has revised the phenomenon of countertransference: Parts of the analyst come to be entangled with those parts of the patient’s own self which they seek to project into their psychoanalyst (Money-Kyrle, 1956; Brenman-Pick, Irma, 1985).

Projective identification is a core feature of the paranoid-schizoid method of defense; it has also come to be recognized as an invariable occurrence in the primitive stages of development. This normalization of the concept has enlarged the scope of the term “projective identification” until it now covers a whole catalogue of different phantasies, many of them widely divergent from the one Melanie Klein originally presented (Rosenfeld, Herbert, 1983).

In particular, the degree of violence by which the self is split and projected is variable. Loosely, the ego that is more mature, secure, and centered upon a good internal object, is less violent in projecting parts of the self.

Instead of using projective identification as a means of desperately expelling an internal catastrophe, it can become an unconscious method of communication, a non-symbolic communication aimed at making the object (the psychoanalyst) feel the experience of the patient very directly (Bion, 1962). In this view, it is the method by which an experience is passed directly on to others. In ordinary conversation, if someone lacks the emotional impact engendered by limited projective identification, they are regarded as flat and tedious.

Moving further along a conceptual axis toward a still lesser degree of violence, there is a relationship in which the ego no longer splits itself, but nevertheless can see itself in the other person. Insight is achieved through “putting oneself in another’s shoes.” This benign form of projection into someone else is the foundation of empathy. There is thus a spectrum of different “uses” of projective identification: expulsion, non-symbolic communication, and empathy (Hinshelwood, 1994).

The influence of one person (the patient) on the intrapsychic world of another has in time become accepted by psychoanalysts outside of the Kleinian group. Joseph Sandler (1976) has noted the way in which the patient mobilizes certain affects, and even behavior, in the analyst. He has called this “role-actualization,” and regards it as a formulation of projective identification in an ego-psychology conceptual framework.

In some schools of psychoanalysis (notably contemporary ego-psychology), the responsiveness of the object and the interpersonal interaction have been elevated to a position as the most important aspects of this concept, over and above the intra-psychic defensive aspects (Ogden, Thomas, 1982).

Melanie Klein’s own assessment was that these kinds of processes are so remote from consciousness that it is hard for people to grasp them. As phantasy activities, they are seen as, improbably, having a definite effect in the real world. The “omnipotence of fantasy” as described by Freud in the Ratman case (1909d) fell short of claiming a real effect in the interpersonal world. Such a claim for projective identifica-

tion is therefore disputed by many. However, the notion is accepted widely, and by psychoanalysts of varied schools, many of whom do not accept the theory of the death instinct on which Klein originally based her interpretation.

ROBERT D. HINSHELWOOD

*See also:* Aggressiveness/aggression; Alpha function; Archaic mother; Arrogance; Claustrophobia; Counter-transference; Heroic self, the; Identification; Infantile psychosis; Internal object; Love-Hate-Knowledge (L/H/K links); Nonverbal communication; Psychotic defenses; Psychotic part of the personality; Symbiosis/symbiotic relation; Symbolic equation.

### **Bibliography**

- Anderson, Robin. (1992). *Clinical lectures on Klein and Bion*. London, Karnac Books.
- Bion, Wilfred. (1962). *Learning from experience*. London: Heinemann; New York: Basic Books.
- Brenman-Pick, Irma. (1985). Working through in the counter-transference. *International Journal of Psycho-Analysis*, 66, p. 157-166 ; republished in Spillius (Ed.) *Melanie Klein Today 2*, London, Routledge, 1988, p. 34-47.
- Freud, Sigmund. (1909d). Notes upon a case of obsessional neurosis. *SE 10*, 151–318.
- Hinshelwood, Robert D. (1994). *Clinical Klein: From theory to practice*. New York: Basic Books.
- Klein, Melanie. (1946). Notes on some schizoid mechanisms. *International Journal of Psycho-Analysis* 27, p. 99–110; republished 1952 in Klein, Heimann, Isaacs and Riviere (Eds.) *Developments in psycho-analysis*, Hogarth; 1975 In *The writings of Melanie Klein III*, 1946–1963, London, Hogarth, p. 1–24 .
- Money-Kyrle, Roger. (1956). Normal countertransference and some of its deviations., *International Journal of Psycho-Analysis*, 37, 360–366.
- Ogden, Thomas. (1982). *Projective identification and psychotherapeutic technique*. New York, Jason Aronson.
- Rosenfeld, Herbert. (1965). *Psychotic states : A psychoanalytic approach*. London, Hogarth; repr. London, Karnac Books, 1985.
- Sandler, Joseph. (1976). Dreams, unconscious phantasies and “identity of perception.” *International Review of Psychoanalysis*, 3, p. 33–42.
- Scott, Clifford. (1946). A note on the psychopathology of convulsive phenomena in manic-depressive states. *International Journal of Psychoanalysis*, 27, 162–155.

Segal, Hanna. (1950). Some aspects of the analysis of a schizo-phrenic. *International Journal of Psychoanalysis*, 31, 4.

Spillius, Elisabeth. (1988). *Melanie Klein today*. London, Routledge.

### Further Reading

Feldman, Michael. (1997). Projective identification: The analyst's involvement. *International Journal of Psychoanalysis*, 78, 227–243.

Sandler, Joseph. (Ed.). (1988). *Projection, identification, projective identification*. London: Karnac Books.

Steiner, John. (1993). *Psychic retreats. Pathological organizations in psychotic, neurotic and borderline patients*. London/New York: Routledge.

---

## PROTECTIVE SHIELD

In Freud's psychophysiological model, the term *protective shield* designates an essential function of the psychic apparatus and the mechanism responsible for it. This function is to protect the organism from potentially harmful excitations coming from the outside world. The protective-shield function, in the context of the theory of the ego, is the result of a complex, dynamic barrier between outside and inside—a barrier in which the protective shield is posited as the most superficial and inert element.

As early as 1895, in "Project for a Scientific Psychology," (1950c [1895]), Freud hypothesized the existence of a mechanism responsible for protecting the "phi neurons" from an excessive influx of exogenous stimuli. In the psychic apparatus, governed by the principle of constancy (elevated quantities produce unpleasure), the sudden irruption of large quantities causes pain. Thus the phi neurons, which receive stimuli perceptions from the external world, must allow only small "quotients" or quantities to pass, but at this point Freud did not specify how this shield quantity ("Q-screens") functioned.

From 1920 to 1926, granting the perceptual apparatus its full importance in relations between the ego and the outside world, Freud hypothesized as an adjunct to the *Preconscious-Conscious* system the protective shield, which constitutes its most superficial layer. This system is operative only with regard to excitations coming from the outside world, and its function overrides that of the layer that receives excitations. By con-

trast, excessive energies that come from within are received directly by the *Preconscious-Conscious* system, which projects them to the outside so that the protective shield can be used against them.

In *Beyond the Pleasure Principle* (1920g), in order to understand the phenomenon of painful repetition in traumatic events, Freud posited in human beings the equivalent of the cortical layer that receives stimuli in living cells. Owing to the constant impact of excitations, the substances of the *Preconscious-Conscious* system and its protective shield undergo a profound modification. To a certain extent, the substance of the protective shield abandons the structure characteristic of living entities and becomes a special membrane that usually keeps exogenous stimuli separate. This inert filter is combined with two other elements to finally make up a true dynamic barrier between outside and inside. In the first place, the sensory organs, which periodically filter out sufficient amounts of the excitations coming from the outside world, constitute another protective shield (a hypothesis taken up again in "A Note upon the 'Mystic Writing Pad,'" [1925]); and finally, there is preparatory anxiety, which is the most dynamic element of the protective-shield system. This line of defense, prepared by a hyper-cathexis to receive and bind the sums of excitation flowing in from the exterior, shields against breakthrough and trauma (a hypothesis confirmed in *Inhibitions, Symptoms and Anxiety*, [1926]). Here, on either side of the barrier that prevents the development of anxiety, consisting of the *Preconscious-Conscious* system and its protective shield, Freud differentiated between two types of anxiety: on one side, the automatic anxiety of the states of the immature ego, which corresponds to an uncontrolled energy and is closely connected with trauma; and on the other, signal anxiety, which depends on a strongly hierarchical mechanism of the ego, which warns it in cases of real, external danger or internal, pulsional danger and allows the ego to mobilize its defenses.

After Freud, the protective-shield function of external objects was emphasized in the work of Donald W. Winnicott and Wilfred R. Bion. In Winnicott's view (1958), the environment, and especially the mother, must present the external world to the infant in a way that preserves the illusion without which the child's encounter with the world would be traumatic. In Bion's view (1962), the mother's capacity for reverie plays a foundational role in the infant's thought processes.

In *Le Penser: Du Moi-peau au Moi-pensant* (1994), Didier Anzieu held that the Skin-ego and the Thinking-ego both fulfill the protective-shield function, each at its own level. The Skin-ego defends the psyche against endogenous pulsional breakthroughs and simultaneously contributes to satisfying the appetite for stimulation; the Thinking-ego protects the Reality-ego from being flooded by thoughts and at the same time ensures that there is continuity in thinking activity. Lastly, Claude Smadja and Gérard Szweg attributed a protective-shield function to the death drive and self-calming behaviors by way of the repeated actions of weak discharges that involve motricity and perception; this is particularly applicable in the case of psychosomatic structures.

Ultimately, since the aim of the psychic apparatus is control over excitations, it can be said that under normal conditions, all mental work fulfills the protective-shield function.

JOSIANE CHAMBRIER

*See also:* *Beyond the Pleasure Principle*; Censoring the lover in her; Conscious processes; Excitation; Hypercathexis; Infant observation (therapeutic); Maternal; Projection; Protective shield, breaking through the; Preconscious, the; Psychic envelope; Skin-ego.

### **Bibliography**

- Anzieu, Didier. (1994). *Le Penser. Du Moi-peau au Moi-pensant*. Paris: Dunod.
- Bion, Wilfred R. (1962). *Learning from experience*. London: Heinemann.
- Smadja, Claude. (1993). A propos des procédés autocalmants du Moi. *Revue française de psychosomatique*, 4, 9–26.
- Szwec, Gérard. (1993). Les procédés autocalmants par la recherche répétitive de l'excitation. Les galériens volontaires. *Revue française de psychosomatique*, 4, 27–51.
- Winnicott, Donald W. (1958). *Collected papers. Through pediatrics to psychoanalysis*. New York: Basic Books.

## **PROTECTIVE SHIELD, BREAKING THROUGH THE**

A tear in the protective shield occurs when excitations from the external world reach such a level of intensity that they overflow the protective systems, or when the

absence of signal anxiety means that external perceptions are not recognized as dangerous by the psychic apparatus. Breach of the protective shield is thus a trauma whose source may be external or instinctual.

In trauma, the excess of excitations that the ego cannot control and work through results in disorganization of the psychic apparatus. This involves an attack on the boundary between inside and outside, upheaval in the mind's topographies with instinctual flushing, development of anxiety, and discharge actions aimed at bringing psychic tension back down to a tolerable level. Freud explained mental breakdown in terms of anticathexes that limit the tearing of the protective shield. Summoning the energies of all the mental systems, these anticathexes impoverish those systems accordingly and produce a reduction or even paralysis of mental activity.

In *Le Penser. Du Moi-peau au Moi-pensant* (1994; Thinking: from the skin-ego to the thinking-ego), Didier Anzieu proposed that in the face of the economic disorder resulting from the breach of the protective shield, the response of the psychic apparatus depends upon the prevailing principle of mental functioning. With the principle of constancy, there is automatic discharge into the external world (acting out), the body (pain, affliction of an organ), or the mind (disturbance of a mental function). In the case of the nirvana principle, excitation itself is what is dreaded; decaathexis, withdrawal, and sometimes hallucinatory projections occur. On the other hand, the constraint of repetition impels the psyche to seek out, whether in dreams or in reality, situations in which a traumatic flooding of stimuli occurred, in order to repair the trauma. Here, repetition of the painful experience aims to bring about retroactive control over the excitation, aided by the development of the anxiety that was initially lacking. Using the protective-shield effects of the death drive, the self-calming behaviors described by Claude Smadja (1993) and Gérard Szweg (1993) counterinvest a traumatic reality that might emerge from within. It should be noted that these solutions all have in common that they are rapid, economical, and the opposite of thought.

Reference is also made to breach of the protective shield in the etiology of borderline and psychotic pathologies. In these cases, object deprivation and early trauma have interfered with the development of the protective-shield system. Moreover, the overwhelmed, malfunctioning, and intolerant ego is



particularly exposed to traumas. According to Donald W. Winnicott (1958), when the mother's holding fails to provide protection to the nursling's immature ego, contact with the external world or the instincts is traumatic. The risk is disintegration of the self.

JOSIANE CHAMBRIER

*See also:* Dementia; Helplessness; Mnemic trace/memory trace; Pain; Physical pain/psychical pain; Primal repression; Protective shield; Trauma; War neurosis.

### **Bibliography**

- Anzieu, Didier. *Le Penser. Du Moi-peau au Moi-pensant*. Paris: Dunod, 1994.
- Smadja, Claude. (1993). Á propos des procédés autocalmants du Moi. *Revue française de psychosomatique* 4, 9–26.
- Szwec, Gérard. (1993). Les procédés autocalmants par la recherche répétitive de l'excitation. Les galériens volontaires. *Revue française de psychosomatique* 4, 27–51.
- Winnicott, Donald W. (1958). The capacity to be alone. *International Journal of Psycho-Analysis*, 39, 416–420.

---

## **PROTON-PSEUDOS**

In the second part (“Psychopathology”) of *Project for a Scientific Psychology* (1950c [1895]) Freud introduced *proton-pseudos* in relation to hysteria. The term relates to Aristotle and the theory of the syllogism, which describes the link between false premises and false conclusions: if the premises are false, if there is an original error, then the conclusion must necessarily be false in spite of the soundness of the intermediary reasoning. The *proton-pseudos* refers to those false premises, the original error.

As an example, Freud described the case of Emma, who at the age of thirteen fled the laughter of the sales staff in a shop, consciously believing that they were laughing at her clothes. However, Emma's reaction in the shop was triggered by a repressed first event from years before, a grocer who had sexually touched her when she was eight.

This example described Freud's whole theory of the two stages of traumatism. He emphasized the intermediary period between the two successive events and that of the psychic maturation at puberty, which

enabled a reconsideration and reinterpretation of the first event, which, when it occurred, could only be recorded psychically without any real integration or metabolization.

Freud described what he called the “determinant conditions for the first hysterical lie” (*πρωτου πσευδος*), stressing the role of puberty and its delayed onset in the human species, a two-stage evolution that he believed explained why “every adolescent must carry the germ of hysteria within him” (1950c, p. 356). This breakdown of trauma theory into two stages echoes the biological view of pubertal evolution, although Freud gradually came to admit in his later work that the time span separating the two stages of the traumatism could in fact be shorter than he had initially believed; the second stage could be prepubertal in certain cases.

Freud discussed Emma's story before the discovery of infantile sexuality, and it is important to put his views into perspective with his letters to Wilhelm Fliess dated May 20, 1896, and December 6, 1896, and Manuscript M, in which he reflected on the different levels at which mnemic traces are recorded and on the “process of stratification” underlying this recording. In France this line of thought resulted in Jean Laplanche's work much later on the mechanisms of “psychic translation and the theory of so-called “general seduction.”

BERNARD GOLSE

*See also:* Eckstein, Emma; Katharina, case of; Lie; Memory; Primary identification; “Project for a Scientific Psychology, A.”

### **Bibliography**

- Freud, Sigmund. (1950a [1897–1902]). Extracts from the Fliess papers. *SE*, 1: 173–208.
- . (1950c [1895]). *Project for a scientific psychology*. *SE*, 1: 281–387.
- Freud, Sigmund, and Fliess, Wilhelm. (1985c [1887–1904]). *The complete letters of Sigmund Freud to Wilhelm Fliess 1887–1904* (Jeffrey M. Masson Ed. and Trans.). Cambridge, MA: Belknap/Harvard University Press.
- Laplanche, Jean. (1989). *New foundations for psychoanalysis* (David Macey, Trans.). Cambridge, MA: Basil Blackwell. (Original work published in 1987)

## PROTO-THOUGHTS

The term “proto-thoughts” refers to primitive sensory and emotional material that has not been subjected to the mother’s alpha function or been manipulated by the infant’s thought-thinking apparatus. Proto-thoughts also correspond to what Wilfred R. Bion called “beta elements.”

In *Learning from Experience* (1962), Bion posited the realm of the protomental as corresponding to objects that are “bad” because they are not in the infant’s possession, and yet excite his or her desire. The infant (or the psychotic patient) tries to rid him- or herself of “bad” objects and proto-thoughts. At this time, at the beginning of mental life, there is no possibility of relief because there are as yet no alpha elements, nor a thought-thinking apparatus to process alpha elements. Bion indicated two later outcomes for proto-thoughts: either flight in the face of frustration, or modification of frustration. The end result is the same if the mother is incapable of receiving the baby’s projections and later returning them to him or her in a tolerable form. If there is failure of the alpha function in the infant or the mother, contact with reality or with living objects also fails. The infant cannot think when things are not present; he or she cannot generate ideas. He or she will tend to act out, and later, the child’s speech will represent an action to liberate the

psyche from an excess of stimuli. The infant’s personality has access only to beta elements, which have no subjective meaning, cannot be used, and are thus evacuated through the eyes, the mouth, the anus, and touching.

The modification of frustration implies the appearance of alpha elements, originating in the mother’s alpha function and later the child’s alpha function. Alpha elements have affective resonance and an associative “penumbra.” They digest proto-thoughts and enable the development of the functions of the personality: intelligence, memory, emotional experiences, dreams, or the distinction between conscious and unconscious. Without the alpha function or alpha elements, there can be no maturation.

PEDRO LUZES

*See also:* Alpha-elements; Beta-elements; Memoirs of the future.

### **Bibliography**

- Bion, Wilfred Ruprecht. (1962). *Learning from experience*. London: Tavistock Publications.
- Luzes, Pedro. Les troubles de la pensée. (1969). (Rapport) Réponse aux interventions. 907–912. *Revue Française de Psychanalyse* 33, (5–6), 727–843.





## PSI ( $\psi$ ) SYSTEM

In his unfinished 1895 "A Project for a Scientific Psychology" Freud defines the psi ( $\psi$ ) system as a subdivision of the nervous system concerned with psychic processes (1950a[1895]). Later, in *The Interpretation of Dreams* (1900a) he used the term to refer to components of the "psychical apparatus."

In the "Project," Freud hypothesized two neuronal systems,  $\phi$  (phi) and  $\psi$  (psi), and employed the principle of inertia and the concept of permeability. Elements of what he called the system were permeable but retained nothing; while the impermeable neurons, equipped with resistance and retentive of quantity, are the vehicles of memory and psychic processes in general, and receive endogenous excitations. Subject to the principle of constancy, neurons that make up the system mitigate its impermeability by "facilitation" (*Bahnung*), creating a permanent alteration in "contact barriers." Freud here adumbrated the concept of the synapse and the idea of synaptic change.

In later work, Freud abandoned the nomenclature of the "Project." He only employed the term " $\psi$  system" in *The Interpretation of Dreams*, where it was used in the plural to describe the components of the psychic apparatus. (1900a, Chap. 7). The systems possess spatial and temporal qualities in terms of arousal, which begins with internal or external stimulation and ends in "innervation" or discharge.

After 1900, Freud employed the term " $\psi$  systems" without as much spatial precision, and made use of new subdivisions: the systems Pcpt. (perceptual), Cs (conscious), Ucs (unconscious), among others.

BERTRAND VICHYN

*See also:* Ego; Principle of (neuronal) inertia; "Project for a Scientific Psychology, A".

### **Bibliography**

Freud, Sigmund. (1900a). The interpretation of dreams. Part I, *SE*, 4: 1-338; Part II, *SE*, 5: 339-625.

———. (1950c [1895]). Project for a scientific psychology. *SE*, 1: 281-387.

---

## PSYCHANALYSE ET LES NÉVROSES, LA

*La psychanalyse et les névroses* followed in the wake of Emmanuel Régis and Angélo Hesnard's important work on the psychoanalysis of the neuroses and psychoses (1914). René Laforgue and René Allendy's book offered the French public a series of writings on psychoanalysis that were replete with clinical examples. The chapters on symbolism and those written from a non-medical point of view were by Allendy.

On the title page, an epigraph from Joseph-Jules Déjerine situated the book firmly in the French medical tradition. The medical qualifications of the authors and a preface by Henri Claude, consultant to hospitals and asylums, emphasized this even further. This latter preface, however, does not mince words: "While I am happy to present Laforgue and Allendy's book on psychoanalysis and the neuroses to the medical public, I have not hidden from the authors that I intend no endorsement of their opinions thereby.... Some of their investigative methods will shock those with delicate feelings, and some of their outrageously symbolic generalizations, though they may possibly apply to those of other races, do not seem to me acceptable to

Latin clinical practice.” He nevertheless recommended the book because he knew, having seen the authors at work, that it was work written in good faith and based on direct experience.

After reading Claude’s preface, Freud wrote to Laforgue that, although he had not yet read the book, he thought that it must be good, since Claude’s reservations showed that the authors had made no compromises and had no fear of controversy.

Laforgue and Allendy indeed presented “the medical public” with the fundamental notions of psychoanalysis, the mechanism of the neuroses, and the technique of this new discipline. Clinical examples, often from their experience at Sainte-Anne Hospital, were adduced to support their arguments. Accordingly, female frigidity, homosexuality, and impotence were discussed. In the chapters on symbolism, Allendy demonstrated his eclecticism and erudition: philology, astrology, and studies of diverse civilizations and religious customs were all brought in to reinforce his argument. This book, by young French doctors who were also practicing psychoanalysts, was the first of its kind. Two years later they founded the Psychoanalytic Society of Paris.

JEAN-PIERRE BOURGERON

See also: Allendy, René Félix Eugène; Claude, Henri Charles Jules; France; Laforgue, René.

### Source Citation

Laforgue, René, and Allendy, René. (1924). *La Psychanalyse et les névroses* (Psychoanalysis and the neuroses). Preface by Henri Claude. Paris: Payot, 254 p.; 2nd ed., 1950 Geneva: Éd. du Mont Blanc; corrected and revised “according to the instructions” of her husband, by Délia Laforgue, with an additional chapter and a second preface by Dr. Logre, 1964.

### Bibliography

Régis, Emmanuel, and Hesnard, Angélo. (1914). *La psychanalyse(sic) des névroses et des psychoses. Ses applications médicales et extramédicales*. Paris: Félix Alcan.

## PSYCHANALYSE ET PÉDIATRIE [PSYCHOANALYSIS AND PEDIATRICS]

When Françoise Marrette, the young analyst in control with Sophie Morgenstern, was working in the Breton-

neau hospital under Dr. Édouard Pichon, she determined that she wanted to “heal with psychoanalysis.” And it worked. Symptoms disappeared, and family equilibrium was restored. It seemed as simple as that. If all pediatricians and general practitioners could benefit from this experience it would be a great day for medicine. She wished to direct the attention of her fellow physicians to the possible benefits of analysis to the patients who came to consult for a variety of ailments. Her thesis was addressed to her colleagues and presented in 1939.

Before recounting her beautiful stories, Marrette felt the need in the first part of her work to define for her lay audience some analytic concepts: instinct, castration complex, agencies of the personality, conscious, preconscious, unconscious, repression, resistance, transference—but this teaches us nothing: the essence is in the struggle between the agencies, the flow of libidinal energy. Human beings were not defined as speaking beings but as storehouses of libido. The author informs us that her first three chapters are theoretical in nature, such that some readers might prefer to go directly to the second “distinctly more concrete and clinical” part.

The first chapter, “Évolution des instincts,” clearly shows that we can describe the behavior and thinking of young children with reference to the breast, excreta, the penis, and without any reference to the father; only the mother is named. The father only appears when the mother goes away “to do the housework, to keep dad happy.” Finally, “the child abandoned by the mother” comes to realize that it is not the only center of its mother’s attention: there is a rival in the form of the father, when there are not extra rivals in the form of brothers and sisters. As is clear in the work of the first child psychoanalysts (Melanie Klein, Donald Winnicott, among others), the remarkably absent father plays only a late role, toward the age of four or five, and “is part of the ambience of the mother.” Analytical theory introduces the father only in a context of oedipal rivalry, when the boy plays the despot, “donning his father’s hat.” In the beginning the child and the mother are one in the child’s experience; for many analysts, they are one and the same flesh.

Marrette’s work contains original suggestions. She brings forth the notion of progressive weaning, at the age of four or five months, to be completed by the seventh or eighth at the latest. If too late, she warns, weaning is experienced as “punishment for oral

aggression,” an assertion that received legitimate criticism. Françoise Marette was more cautious when it came to educating the sphincter. Whereas many analysts claimed that children should receive potty training at the end of the first year, she waged war against abusive sphincter training: not before twenty-four months. In this she was innovative. Equally with regard to the discovery of sexual differences and the pleasure of masturbation.

The role of the father was also a problem when it came to the Oedipus complex and the castration complex. When her work was presented in 1962, mention was made of the fact that she had married Dr. Boris Dolto in 1942. When she became a mother she acquired “experience that made her one of the representative personalities of the contemporary French psychoanalytic movement.”

The second part of her thesis gives us a sense of this: in clinical vignettes and moving stories extolling the merits of psychoanalysis, sixteen children came to see her accompanied by their parents. She initially received the family all together, and then the parents withdrew to the waiting room. The children were then free to express themselves, to draw and use clay, to play and speak. But she did not see the parents again at the end of the session with the child. Some analysts and institutions immediately separate parents and children, which deprives the analyst of significant information that is indispensable for an understanding of what the child is experiencing and thus prevents the analyst from having an effective contact with the parents.

Through her account of these consultations, generations of physicians gained an increased understanding of the emotional lives of children and discovered that they had an educational role to play, whether they liked it or not. Marette, inventively, invited the children to use speech and play in order to free themselves from regressive or aggressive and poorly-adapted behavior. It is a pleasure to witness the children, determined workers, undertaking an analytic cure and inviting their parents to question the influences that condition them, all without their realizing it.

Attentive readers also discover the path that analysts must follow if they don't want to become obstacles in the way of the analysis. The thesis concludes with: “The castration complex is ineluctable in the course of human development [...]. This work has not enabled us to deal with the very many questions relating to the castration complex. Its aim is to inter-

est our non-psychoanalyst colleagues in the fundamental importance of the Oedipal stage in the history of individual development and its role in the etiology of functional symptoms and behavioral disorders in order to demonstrate the therapeutic interest of psychoanalysis.”

BERNARD THIS

See also: Armand Trousseau Children's Hospital; Dolto-Marette, Françoise; Morgenstern-Kabatschnik, Sophie; Pichon, Édouard Jean Baptiste.

### Source Citation

Marette (Dolto), Françoise. (1940). *Psychanalyse et Pédiatrie. Le complexe de castration. Étude générale. Cas cliniques.* Préf. Édouard Pichon, Paris: Éd. A. Legrand; Dolto, Françoise. *Psychanalyse et Pédiatrie.* Paris: Le Seuil, coll. “Points” 1971.

---

## PSYCHANALYSE, LA

The *Société française de psychanalyse* (SFP, French Psychoanalytic Society), was founded on June 18, 1953, following the resignation of Françoise Dolto, Juliette Favez-Boutonier, Jacques Lacan, Daniel Lagache, and Blanche Reverchon-Jouve from the *Société Psychanalytique de Paris* (SPP, Paris Psychoanalytic Society). The new group did not found a journal, but rather published a series of eight “notebooks” that came out according to no fixed schedule under the title of *La Psychanalyse*. The subtitle was *Freudian Research and Teaching of the Société Française de Psychanalyse*. The titles of the series, all published by Presses Universitaires de France, are as follows:

- I. On Speech and Language (1956)
- II. Clinical Miscellany (1956)
- III. Psychoanalysis and the Human Sciences (1958)
- IV. The Psychoses (1958)
- V. Critical Essays (1959)
- VI. Structural Perspectives (1961)
- VII. Feminine Sexuality (1964)
- VIII. Fantasy, Dream, Reality (1964)

The first volume contained Lacan's “Rome Report” from the new society's first congress in September 1953, as well as all the presentations made at that

conference. Volume VI, “Structural Perspectives,” published the acts of the international congress held at Royaumont in 1959. It included Daniel Lagache’s paper “Psychoanalysis and Personality Structure,” followed by Jacques Lacan’s “Remarks on Daniel Lagache’s Presentation: ‘Psychoanalysis and Personality Structure.’” It also included Lacan’s “The Direction of the Treatment and the Principles of Its Power” and Dolto’s “Personology and Body Image.” Volume VII included the proceedings of an international conference on feminine sexuality held in Amsterdam in 1960. It included “Guiding Remarks for a Conference on Feminine Sexuality,” by Lacan, and papers by Dolto on “The Destiny of Feminine Genital Libido” and by Wladimir Granoff and François Perrier on “Feminine Ideas and the Problem of Perversion in Women.” This volume also included numerous papers and translations of texts, such as Ernest Jones’s “Early Female Sexuality” and Joan Rivière’s “Womanliness as Masquerade.”

The members of the S.F.P. disbanded in 1963 and announced the group’s dissolution in 1964, shortly after the publication of the last volume of *La Psychanalyse*. The volumes were published without an editorial committee. Among the numerous French authors whose works were included were Piera Aulagnier, Serge Leclair, Maud Mannoni, Octave Mannoni, Gisela Pankow, Guy Rosolato, Mustapha Safouan, Daniel Widlöcher. Foreign authors published in *La Psychanalyse* included Michael Balint, Martin Grotjahn, Susan Isaacs, Jacques Schotte, and Alphonse de Waelhens.

JACQUES SÉDAT

*See also:* France; Société française de psychanalyse.

## PSYCHE / PSYCHISM

In their most general sense, the words “psyche” and “mind” refer to phenomena and processes associated with the “soul,” understood empirically, without consideration of its content (conscious, unconscious, life principle) but excluding any metaphysical or religious meaning (unity of the soul, distinction between soul and body, immortality).

Although “psyche” and “mind” can, to some extent, be considered synonymous, the first is not

really a modern term (except, obviously, in modern Greek) and its use is based on the desire to allude to a context that is as much literary as philosophical. Freud rarely used it outside of such a context (however, see *An Outline of Psychoanalysis*, 1940a [1938]). Nonetheless, in *The Interpretation of Dreams* (1900a), he refers to the fact that “the Ancients . . . provided Psyche with butterfly wings.” The mythical character of Psyche—who, in a story by Apuleius, loses her husband, Eros, after having looked upon him as he slept—has been the theme of numerous works of literature and art. The fact that, as a common noun, the word “psyche” refers to a type of mirror, has led us to reconsider the concept of the soul as a narcissistic double.

The word “mind” on the contrary is—or claims to be—“scientific.” As such it can only be defined with reference to the science whose object it supposedly represents, namely psychology. While the concept of “consciousness” has escaped definition (we can only speak of lived experience), it is likely that any definition of mind will turn out to be circular, or simply limited: “Mind” is the object of psychology as a discipline distinct from metaphysics and biology. But since the limits and principles of psychology are themselves problematic, the difficulty remains.

Introducing the concept of the unconscious does nothing to alleviate the difficulty, since mind cannot be defined as the simple addition of conscious to unconscious. For Freud unconscious is not identical with non-conscious, and the question of just how mind should be defined remains. Hence a reliance on a history of the concept, a history in which, it should be noted, the problem of conscious versus unconscious has only marginal importance.

To vastly oversimplify the matter, we can say that for the early Greeks, “psyche” referred to the breath of life, and for Descartes the soul was identified with consciousness. In Homer the psyche, sometimes represented with butterfly wings, resembles a dream and an unreal image of a man, while the breath of life is called *thumos*. In the Pythagoreans and Plato the psyche appears as a reality belonging to the moral order. It is capable of good or evil, it will be judged, and it is immortal. But it is also in Plato that we find—following chapter 4 of the *Republic*—the celebrated distinction between intelligence, anger (*thumos*), and the base instincts, which Freud associated, in 1923, with the concepts of ego, superego, and id. This Platonic distinction enriched the notion of the soul with anthropological features and supplied the

foundation for a rational and empirical psychology, which was developed in Aristotle, who emphasized, although not exclusively, mental functions that were vital, if not biological (biology did not yet exist as an autonomous science). In fact the Aristotelian notion of the psyche covers a very broad range of functions (metaphysical, “psychological” in the modern sense, biological), while “mind” was not distinguished until the modern era.

The important milestones in this development are not those of the history of the unconscious but of the genesis of empirical psychology. The appearance in 1590, in the Latin title of a work by Rudolf Goeckel, of the word *psychologia*, in Greek (although the term did not exist in ancient Greek), indicates the tendency of Renaissance culture to use the term to delimit a specific field of thought and research. However, the decisive event was the distinction made by Christian Wolff, in 1732 and 1734, in two works respectively entitled *Psychologia Empirica* and *Psychologia Rationalis*. Even though Wolff’s first text remains highly speculative, the initial break with rational psychology has been made, through metaphysics, along with a top-down demarcation of the object that the term “mind” would designate. A bottom-up demarcation would take place in the nineteenth century with the development of scientific biology.

What of the unconscious? It is true that Descartes, by defining *mens* in terms of thought and by rejecting the scholastic concept of soul and its vital aspects, made it necessary to introduce, as early as the seventeenth century, the concept of the unconscious (the term itself did not appear until the eighteenth century and did not become popular until the nineteenth). But when, in German romantic philosophy, the concept was used to designate a form of foundation or first principle, the connection with representation would be broken. For example, Eduard von Hartmann, in his famous *Philosophy of the Unconscious* of 1869, describes a form of panpsychism that makes it possible to introduce the notion of psychism. Freud himself was familiar with this point of view. When, in a well-known passage from *The Interpretation of Dreams*, he wrote that “the unconscious is the true reality of the psyche,” he destroyed any possibility of defining mind in terms of representation (conscious or non-conscious) and left untouched the problem of the characteristics that could be used to distinguish the psychic from the biological, and from metaphysics.

It is only through an epistemology of psychology that the concept of mind can be defined. And since psychology, in its current form, comprises various disciplines whose epistemological foundations are difficult to reconcile, we must resign ourselves to the fact that the terms “psyche” and “mind” designate only those highly amorphous objects considered by psychology as understood in the broadest sense of the terms.

YVON BRÈS

*See also:* Agency; Animus-Anima (analytic psychology); Archetype; Collective unconscious; Determinism; Drive/instinct; Maternal reverie, capacity for; Ontogenesis; “Outline of Psychoanalysis, An”; Phylogenesis; Primal; Principle; Psychosomatic limit/boundary; Psychic apparatus; Psychic reality; Self; Strata/stratification; Thought-thinking apparatus; Unconscious, the.

### Bibliography

- Freud, Sigmund. (1900a). The interpretation of dreams. Part I, *SE*, 4:1–338. Part II, *SE*, 5:339–625.
- Hartmann, Eduard von. (1931). *Philosophy of the unconscious. speculative results according to the inductive method of physical science* (W. C. Coupland, Trans.). London: Routledge. (Original work published 1869)
- Wolff, Christian (1968). *Psychologia empirica*. Hildesheim: Olms. (Original work published 1732)
- . (1968). *Psychologia rationalis*. Hildesheim: Olms. (Original work published 1734)

---

## **PSYCHÉ, REVUE INTERNATIONALE DE PSYCHANALYSE ET DES SCIENCES DE L'HOMME (PSYCHÉ, AN INTERNATIONAL REVIEW OF PSYCHOANALYSIS AND HUMAN SCIENCES)**

Founded in 1946 on the initiative of Maryse Choisy, *Psyché* is defined as an “international review of psychoanalysis and human sciences.” The first issue of this monthly review appeared in November 1946 and was followed by another 120 issues until 1963.

The idea for the review took root among a circle of intellectuals that Maryse Choisy brought together between 1944 and 1945. This group of poets, writers, philosophers, and theologians met to exchange ideas



on a variety of topics that sometimes included occultism, astrology, and clairvoyance. Philosopher Pierre Bachelard introduced the psychoanalytic element, as did psychoanalyst Juliette Boutonier, whose presence between 1945 and 1946 drew in other analysts like André Berge, Françoise Dolto, René Laforgue, and George Mauco.

In the course of time, a certain number of analysts from the Paris Psychoanalytic Society thus accepted Maryse Choisy's proposition to create the review *Psyché*. The *Revue française de psychanalyse* (French Review of Psychoanalysis) had not yet reappeared after the war and *Psyché*, with its vocation extending to include the "human sciences" was closer to the framework of applied psychoanalysis, being comparable in this respect to *Imago*.

Maxime Clouzet (Maryse Choisy's husband) was director of the review and the committee of patronage brought together some eminent personalities of the time, people like Louis de Broglie, perpetual secretary of the of the Academy of Science, Pierre Janet from the Institute, Pierre Teilhard de Chardin, the discoverer of the Sinanthropus, Charles Baudouin, Drs. John Leuba, René Laforgue, Angélo Hesnard, Louis Le Guillant, Charles Odier, and Édouard Toulouse.

Maryse Choisy directed a small team that included André Berge and George Mauco, both psychoanalysts, as well as other collaborators with artistic and literary vocations in charge of completing the "monthly chronicle" under headings like Painting, Books, Theater, Cinema, and a Review of Reviews. The copy desk was the responsibility of Jacqueline Massière (the future Jacqueline Cosnier), a young philosopher in analytic training.

The first issues enjoyed the benefits of a group of varied and competent collaborators. At the end of 1945, Maryse Choisy had managed to acquire the collaboration of the (rare) psychologists and psychiatrists who practiced psychoanalysis or who were beginning to take an interest in it, as well as eminent personalities from the worlds of science, literature, and philosophy.

In the course of the different issues we thus find the names of André Maurois, Edmond Jaloux, Louis de Broglie, Pierre Teilhard de Chardin, Marcel Griaule, Georges Dumézil, Karl Jaspers, Martin Heidegger, Claude Lévi-Strauss, Georges Heuyer, Serge Lebovici,

Françoise Dolto, Béla Grunberger, Juliette Boutonier, Octave Mannoni, René Laforgue, Charles Odier, René Allendy, Marie Bonaparte, and Angélo Hesnard. It is worth pointing out that the last five of these were among the seven authors in the first issue of the *Revue française de psychanalyse* in 1927.

Quickly enough, *Psyché* began to publish contributions by psychoanalysts from other societies in other countries: Emilio Servadio and Nicola Perrotti of the Italian Society, Igor Caruso from Austria, John R. Rees from London, Karen Horney and René Spitz from the United States, Heinrich Meng from German-speaking Switzerland, while the committee of patronage was completed with professors Jean Delay, Henri Gouhier, Daniel Lagache, and Jean Lhermitte.

Congresses came to be organized as an extension of the review: the Royaumont study week on "The fate of collective man" (1947), the International Congress of Catholic Psychiatrists, Analytical Psychotherapists and Educational Psychologists (1949). *Psyché* published the proceedings of these congresses as well as reports on the different meetings relating to the field of psychology. A supplement to the review also appeared with installments of the "Dictionary of Psychoanalysis and Psychological Technique," directed by Daniel Lagache, the outline of the future *The Language of Psychoanalysis*.

*Psyché* played a role in organizing and bringing together the psychoanalytic milieu immediately after World War II. However, the eclecticism and the "ecumenical" preoccupations of its instigator, combined also with the reorganization of the psychoanalytic societies and the reappearance of the *Revue française de psychanalyse* (in 1948), which was soon complemented by the creation of other specific reviews, led to two phenomena that were to reduce its importance in the analytic world: psychoanalysts had other places where they could exchange ideas, and because of this the review's para-analytic and extra-analytic cultural aspects assumed increasing importance. Moreover, from issue number 15 onward the initial sub-heading of the review, "International Review of Psychoanalysis and Human Sciences," changed to "International Review of Human Sciences and Psychoanalysis."

JACQUELINE COSNIER

See also: Choisy, Maryse; France; Laforgue, René.

## **PSYCHE. ZEITSCHRIFT FÜR PSYCHOANALYSE UND IHR ANWENDUNGEN**

*Psyche. Zeitschrift für Psychoanalyse und ihr Anwendungen* (*Psyche: A Journal for Psychoanalysis and Its Applications*) is the most important and most widely distributed German-language psychoanalytic journal. Seven thousand copies of it are printed every month.

Founded in 1947 by Hans Kunz, Alexander Mitscherlich, and Felix Schottlaender, it first appeared with the subtitle *Jahrbuch für Tiefenpsychologie und Menschenkunde in Forschung und Praxis* (*Yearbook for Research and Practice in Depth Psychology and the Human Sciences*). It adopted its current name in 1966, thus leaving no doubt about its Freudian orientation.

In the beginning *Psyche* represented a mixture of the teachings of Carl G. Jung, Sigmund Freud, Alfred Adler, and the neo-analysis of Harald Schultz-Hencke. This eclecticism, which escaped the attention of the first editors, was a hangover from the period when National Socialism grouped together the most diverse therapeutic schools in the Deutsches Institut für psychologische Forschung und Psychotherapie (German Institute for Psychological Research and Psychotherapy). In the 1950s Mitscherlich managed to acquire contributions from emigrant Freudian authors like Michael Balint, Erik H. Erikson, Heinz Hartmann, and Edith Jacobson, thus establishing a Freudian tradition that still characterizes the journal in 2005.

From its first decades up until the early 1970s, the journal aimed primarily to repromote knowledge of Freudian psychoanalysis, which had been destroyed or brushed aside in Germany by National Socialism, and to raise the scientific level of German psychoanalysis to that of international standards. Moreover, its editor Alexander Mitscherlich (who worked alone after 1968) sought from the beginning to relate psychoanalytic questions to social and cultural questions and to give the periodical the interdisciplinary orientation that has become its hallmark. Problems raised by Freud's theory of culture were always given priority treatment, although not to the detriment of the theoretical and clinical aspects of psychoanalysis.

In the 1970s and 1980s the journal opened its pages to discussion of the tense relations between psychoanalysis and feminism, and to the prickly question of to what degree and with what consequences the German psychoanalysts who did not emigrate between 1933

and 1945 had compromised themselves in National Socialist health policy. This question, which relates to the historical and moral complicity of German psychoanalysts, was the subject of an intense several-year controversy between the editors of the review and representatives of the German psychoanalytic societies. This controversy showed *Psyche* for what it really was: a journal that never considered itself merely a mouthpiece for the German psychoanalytic community.

After the death of Alexander Mitscherlich in 1982, the new editors—Margarete Mitscherlich, Helmut Dahmer, and Lutz Rosenkötter—continued the well-tried editorial policy of the journal. Since 1990 Margarete Mitscherlich has been the sole editor.

HANS-MARTIN LOHMANN

See also: Germany; Marxism and psychoanalysis; Mitscherlich, Alexander.

---

## **PSYCHIC APPARATUS**

The notion of psychic apparatus (or of the intellect) is common in Freud's work from the very start (cf. for example, the article of 1898b, "The Psychological Mechanism of Forgetfulness"). It appears continuously from then on, and is the title of Chapter I of one of his last texts, *An Outline of Psychoanalysis* (1940a [1938]). It was borrowed from the vocabulary of nineteenth-century psychologists who were seeking to accord to animal and human mental functioning a representation conforming to the exigencies of the natural sciences (physiology and especially physics).

Considered from a static point of view, the Freudian versions of the psychic apparatus correspond to what was subsequently called the "topographies." The first one (yet to be designated by this word) appears in Chapter VII of *The Interpretation of Dreams* (1900a) and essentially comprises the distinction between the unconscious, the preconscious, and the conscious. The second topography (cf. *The Ego and the Id*, 1923b) distinguishes between id, ego, and superego, which are depicted in a diagram reminiscent of an egg, that was to be reworked into a slightly different form in Seminar XXXI of the *New Introductory Lectures on Psychoanalysis* (1933a [1932]).

Still from the start the notion of psychic apparatus also pointed to a dynamic perspective: it presupposed something that functions. The schema outlined in Chapter VII of *The Interpretation of Dreams* occupies a place within the time's general psychological framework concerned with the passage from perception to movement (to be found, for example, in Henri Bergson's *Matter and Memory* of 1896, and which corresponds with experimental psychology's stimulus-response pairing). Freud's aim was to demonstrate how "unconscious systems," which he was not yet referring to as "complexes," acted upon the information gathered by the perceptual apparatus to create representations and conscious movement, and in particular, in this respect, oneiric representations. Likewise the group comprising the three instances—id, ego, and superego—was also to have permitted an accounting of psychic functioning, in particular the resolution of certain difficulties regarding the unconscious and the non-conscious. Freud never specifically says whether the id, ego, and superego were to replace the schema in *The Interpretation of Dreams*, thus rendered obsolete, or only to add another perspective to it.

In more precise terms, the Freudian notion of psychic apparatus entails the idea—borrowed from physics—of a sort of "energetic economy." Although he never attempted to specify the precise nature of sexual energy (as would Wilhelm Reich), nor, even less, that of psychic energy in general, Freud, (inspired by Gustav Fechner), conceived the workings of the human psyche from the perspective of the flow, equilibrium, and transformation of a certain "energy." The "pleasure principle" articulated the idea that when tension in the psychic organism reaches a certain level, a release will ensue which is lived subjectively in the form of pleasure, but whose objective effect is to lower tension and avoid the dangers of overflowing. Although the pleasure principle itself derives from thermodynamics, the notion of sublimation, which envisions the transformation of a socially-incompatible sexual "energy" into socially-acceptable activities, originates in chemistry.

Finally it is worthwhile to note that some of the most suggestive representations of the psychic apparatus refer to models taken from optics (cf. for example the passage cited above from *The Interpretation of Dreams*, as well as the *Question of Lay Analysis*, 1926e). The fact that Freud sometimes uses the adjective *psy-*

*chisch* (psychic), sometimes *seelisch* (relating to the intellect), does not seem significant, as the two words may be considered synonymous.

The notion of psychic apparatus and the uses Freud puts it to raise the issue of the value models taken from the physical sciences have for psychoanalysis. Some, such as George Politzer and Jean-Paul Sartre, have concluded them to be an inexcusable misunderstanding of the psyche's specificity. Indeed as Sartre says in *Critique de la raison dialectique* (1960) concerning the notion of defensive mechanism, that such a representation "burdens the workings of the ego with an a priori inertia." If, as Georges Politzer reasons, the psyche as such is a kind of drama, no apparatus could represent it. These arguments could be countered by noting that these are metaphors—that topography—despite its etymology—does not imply the brain as locale, but only a "locus of the psyche" as such, and that from a dynamic point of view the flows and transformations of energy are not physiological or chemical processes. Freud was perfectly aware of these difficulties and explained himself clearly, for example concerning the problems posed by the visualization of the psyche (cf. *New Introductory lectures on Psychoanalysis*, 1933a, xxxi). Nevertheless for him, the representations he called "psychic apparatus" seemed to be much more than merely images, useful but misleading, which as Plotinus and Bergson have taught, should be employed with other images, incompatible with them, to avoid one's being duped by them. Freud seems to have tried to forge a path between the neurological perspective, where psychic functions are supposedly lodged in their cerebral headquarters (a view he no longer shared at the time he invented psychoanalysis), and the phenomenological perspective which excluded anything to do with topographical location, functioning, or mechanical operation. He adopted this perspective at times, furthermore, but not in those texts where the notion of psychic apparatus intervened. Still, this path seems so narrow we may wonder if it is navigable. Without going so far as to challenge its legitimacy, we may at least consider it—in Freud's own words—"provisional."

YVON BRÈS

*See also:* Agency; Consciousness; Discharge; Disorganization; Dynamic point of view, the; Ego; *Ego and the Id*, *The*; Excitation; Id; *Interpretation of Dreams*, *The*; Metapsychology; Mnemic trace, memory trace; Model; "Note

upon the ‘Mystic Writing Pad,’ A”; “Outline of Psychoanalysis, An”; Perception-consciousness (Pcpt.-Cs); Pleasure principle; Primary process, secondary process; Principle of consistency; Protective shield; Psi system; Quantitative, qualitative; Regression; Structural theories; Superego; Topographical point of view; Unconscious, the.

### **Bibliography**

- Freud, Sigmund. (1900a). The interpretation of dreams. *SE*, 4–5.
- . (1923b). The ego and the id. *SE*, 19: 1–66.
- . (1926e). The question of lay analysis. *SE*, 20: 177–250.
- . (1933a [1932]). New introductory lectures on psychoanalysis. *SE*, 22: 1–182.
- Sartre, Jean Paul. (1960). *Critique de la raison dialectique*. Paris: Gallimard.

### **Further Reading**

- Boesky, Dale (1988). The concept of psychic structure. *Journal of the American Psychoanalytic Association*, 36(S), 113–136.
- Schafer, Roy. (1988). Discussion of panel presentations on psychic structure. *Journal of the American Psychoanalytic Association*, 36(S), 295–312.

## **PSYCHIC CAUSALITY**

In Sigmund Freud’s work, the term “psychic causality” designates a group of unconscious psychic processes (conflicting drives, structural conflicts, narcissistic and object investments) and defensive mechanisms (repression, denial, splitting, rejection) that are assumed to be the origin of the phenomena of day-to-day life (dreams, slips, failed acts, creative acts) as well as of neurotic and psychotic symptoms. Operating according to the logic of psychic conflict and primary processes, psychic causality is said to be dissociated from the concept of “psychic reality,” and from Freud’s ongoing attempt to discover the etiology of neuroses, psychoses, and perversions.

The concept appears indirectly throughout Freud’s work but he never examined it at any length. It is known that Freud came upon the idea at the Salpêtrière, working with Jean Martin Charcot in 1885–1886. As he subsequently wrote, “[Charcot] succeeded

in proving, by an unbroken chain of argument, that these paralyzes were the result of ideas which had dominated the patient’s brain at moments of a special disposition” (1893f, p. 22). By 1890 Freud had extended this to all neuroses. In an article entitled “Psychical (or Mental) Treatment,” he claimed that “in some at least of these [neurotic] patients the signs of their illness originate from nothing other than *a change in the action of their minds upon their bodies* and that the immediate cause of their disorder is to be looked for in their minds” (1890a, p. 286). Based on the article, psychic causality is not yet explicitly linked to the unconscious mechanisms he would subsequently describe. However, very early in his work he postulated a “sexual etiology in all cases of neurosis but in neurasthenia the neurosis is actual; in psychoneuroses factors of an infantile nature are at work” (1896c). In 1898, in “Sexuality in the Etiology of the Neuroses” (1898a), he referred to “unconscious psychic traces.”

Psychic causality implies the ability to substitute for a set of apparently unrelated facts an explanatory system based on assumptions that provide them with consistency and can be used to describe the laws governing their interrelations. All of Freud’s work revolves around “two opposed conceptions of causal necessity” (Dayan, Maurice, 1985), one of which was responsible for integrating individual differences in a coherent structure, the other tending to emphasize the subject’s singularity and originality. There is a gradual complication of the notion of psychic causality in Freud. In 1895 he proposed two models simultaneously: a causality of psychic facts conceived as part of a system that we would now call cognitivist and neurobiological (see, “Project for a Scientific Psychology,” 1950c [1895]) and an “event-driven” traumatic conception of neurosis. His “neurotica” is supposed to comprise hysteria and obsessional neurosis based on the psychic traces of sexual aggression experienced during childhood and reactivated later on.

The (relative) abandonment of this etiology (letter to Wilhelm Fliess on September 21, 1897) would confirm the effectiveness of the unconscious fantasy as a psychic act. *The Interpretation of Dreams* (1900a) and the first topographical subsystem enabled him to describe the laws underlying the operation of unconscious processes for which time and contradiction have no meaning, which shift and condense to produce not only dreams but the lapses and parapraxes of

the “psychopathology of everyday life” (1901b), together with neurotic symptoms and delusions. Freud thus established the absence of a barrier or discontinuity between the normal and the pathological, a key idea in psychoanalysis. The same unconscious psychic mechanisms are responsible for both modes of existence.

From the first to the second topographical subsystem (1923), the Freudian notion of psychic causality was radically modified. The description of the mental apparatus became increasingly complex. Mental and psychopathological facts are now the result of relations of force between id, ego, and superego agencies, and the dualism between the libido and the death drive. Metapsychology, which combines topological, dynamic, and economic points of view is the final version of this new way of thinking about psychic causality. At the same time, the role of object relations and the weight of civilization on possible subject pathologies were substantiated. The *Versagung* (refusal) that social reality forces desire to confront, the privation (*Entbehrungen*) that someone like Judge Schreber, unable to have a child, experienced, or the disappearance of the love object are considered as helping to trigger neuroses and psychoses.

In 1933, in the *New Introductory Lectures on Psychoanalysis* (1933a), Freud proposes a general theory of neurosis based on the combination of three factors: a refusal of a reality that is unsatisfactory for the id, fixation at a stage prior to libidinal development, and idiosyncratic disposition to the conflict that characterizes the potentially neurotic subject. The neurosis is triggered by regression to the points of attachment; in the case of psychosis and perversion specific defense mechanisms—splitting, denial, rejection (“Fetishism,” 1927e, “Splitting of the Ego in the Process of Defence,” 1940e [1938])—are also involved. In his last writings, *Moses and Monotheism* (1939a) and *An Outline of Psycho-Analysis* (1940a), published after his death, Freud insists on the particular causal value of the superego that is associated with phylogenesis and the threat of castration, which “[the boy] experiences [as] the greatest trauma of his life and introduces the period of latency with all its consequences” (1940a, p. 155). Whatever the case, Freud reaffirms the continuity of the normal and the pathological: “[T]he neuroses do not differ in any essential respect from the normal” (1940a, p. 184). The normal, neurotic, or psychotic individual will die “of his internal conflicts” (p. 150).

Freud also again insists on the central importance of conflict between the body and the mind, and their interrelations, in his conception of psychic causality, which as we have seen had a number of “avatars.”

It could be said that, since Freud, all writers on psychoanalysis have tried to enrich the notion of psychic causality with their own theories, which are inspired by archaic fantasies and the individual’s traumas and personal history. Jacques Lacan’s work represents an original attempt to define psychic causality on a structuralist basis by identifying the unconscious with the chain of signifiers. “The only causality the analyst knows is always that of the cause,” he wrote in *Seminar XI*. At the end of his life, he attempted to systematize intrapsychic activity using mathemes. The contributions of psychosomatic analysts (Georg Groddeck, Franz Alexander) and those of the French school who followed the work of Michel Fain and Pierre Marty reopened the question of psychic causality by focusing on Freud’s initial question: the relationship between physical and mental disturbances.

For André Green “the term psychic causality is used by Freud rather loosely, without any genuine theoretical support” (1995). In spite of the lapidary nature of this claim, it must be acknowledged that disagreement over the nature of the concept was the origin of the split in the psychoanalytic movement. For example, Otto Rank believed he had discovered the cause of neurosis in the traumatism of birth. Wilhelm Reich focused on the idea of the sexual frustration imposed by civilization (*The Function of the Orgasm*, 1927). Sándor Ferenczi, after attempting to illustrate Freud’s phylogenetic theory and the concept of regression (*Thalassa*, 1924), reaffirmed the reality of sexual trauma experienced by the infant, and did so against Freud’s advice (“Confusion de langues entre les adultes et l’enfant. Le langage de la tendresse et de la passion,” 1933).

Epistemologists, making use of the criticisms that quantum mechanics and the theory of relativity had formulated concerning causality in physics, have contested the causal ambitions of psychoanalysis. Attacking Freud’s system of causal interpretation, Ludwig Wittgenstein referred to purely “aesthetic” relationships (*Cambridge Lectures*, 1932–1934). Karl Popper contested the scientific status of psychoanalysis, which was, according to him, a self-validating theory (*The Logic of Scientific Discovery*, 1934).

André Green, in his *La Causalité psychique* (1995), supplied a masterful criticism of the attempts of biology, neuroscience, and anthropology to invalidate the concept of Freudian causality. Nonetheless, in the realm of physics, measurement can be used to provide uniform descriptions of the natural universe. As far as we know, the relative force of mental drives does not lend itself to any precise form of measurement. Psychoanalysts are content to state that “it works. . . .” As Piera Aulagnier wrote, we are forced to recognize that psychoanalysis can lay claim to “necessary” but never “sufficient conditions” as these are understood by philosophy and mathematics.

JEAN-PIERRE CHARTIER

*See also:* “Claims of Psychoanalysis to Scientific Interest”; Deferred action; Need for causality; Psychogenesis/organo-genesis; Psychosomatic; Signifying chain; Synchronicity (analytical psychology).

### Bibliography

- Dayan, Maurice. (1985). *Inconscient et Réalité*. Paris: Presses Universitaires de France.
- Freud, Sigmund. (1890a). Psychical (or mental) treatment. *SE*, 7: 281–302.
- . (1893f). Charcot. *SE*, 3: 7–23.
- . (1896c). The aetiology of hysteria. *SE*, 3: 186–221.
- . (1898a). Sexuality in the aetiology of the neuroses. *SE*, 3: 259–285.
- . (1900a). The interpretation of dreams. Part I, *SE*, 4: 1–338; Part II, *SE*, 5: 339–625.
- . (1901b). The psychopathology of everyday life. *SE*, 6.
- . (1923b). The ego and the id. *SE*, 19: 1–66.
- . (1927e). Fetishism. *SE*, 21: 147–157.
- . (1933a). New introductory lectures on psychoanalysis. *SE*, 22: 5–182.
- . (1939a). Moses and monotheism. *SE*, 23: 1–137.
- . (1940a). An outline of psycho-analysis. *SE*, 23: 144–207.
- . (1940e [1938]). Splitting of the ego in the process of defence. *SE*, 23: 271–278.
- . (1950a [1887–1902]). Extracts from the Fliess papers. *SE*, 1: 173–280.
- . (1950c [1895]). Project for a scientific psychology. *SE*, 1: 281–387.
- Green, Andre. (1995). *La Causalité psychique. Entre nature et culture*. Paris: Odile Jacob.

## PSYCHIC ENERGY

The hypothesis of a psychic energy constitutes a fundamental postulate of psychoanalytical theory. It is omnipresent, from the theory of sexuality to that of the dream, of anxiety, of drives, and of affects. Of the three great metapsychological points of view, the economic one is directly founded on it, but the dynamic and topographical points of view imply it also. Any psychic movement can, in the last analysis, be linked to a phenomenon of energy. Nevertheless, this economical point of view, this “energy metaphor,” has often been criticized, put into question, and even abandoned by some.

The notion of psychic energy has its source in the works of neurophysiologists at the end of the 19th century, Sigmund Exner in particular, or in the psychophysics of Gustav Fechner, and it is present in the psychiatry of that epoch. In psychoanalytical writings, it surfaced first under the pen of Josef Breuer in *Studies on Hysteria* (1895d). He described this energy as a “nervous tension,” or “Intracerebral Tonic Excitations” (p. 192), contained in the reservoir of the nervous fibers. This “quiescent” energy can be put into movement and become active.

Sigmund Freud, starting with *Studies on Hysteria*, introduced the idea of a tendency “to maintain cerebral excitation at a constant level,” a principle of constancy that will become a principle behind the balance of pleasure and unpleasure. He first developed the notion of psychic energy in the “Project for a Scientific Psychology” (1950c [1895]) in a neuronal version; in *The Interpretation of Dreams* (1900a), the neurophysiological model disappeared and psychic energy was inserted into a theory of thought. The energy could be “free,” in the case of “primary processes,” or “bound,” as in “secondary processes.” In the latter, the binding or connecting of psychic energy is related to the linking of representations and to the “taming” of the tendency for “discharge.” “Thought must concern itself with the connecting paths between ideas, without being led astray by the *intensities* of these ideas” (p. 602). The quantities of energy conveyed by these

two kinds of thought are different; secondary processes of thought only convey much weaker quantities of energy, while a surfeit of non-bound energy can occur, to weaken these thought processes.

For Freud, with the theory of drives, the equating of psychic energy and the libido was reinforced; the libido constituted, therefore, the essence of psychic energy. However, he always remained reticent about Carl Gustav Jung's proposition of conflating psychic energy totally with the libido, and he held onto the idea of a psychic energy distinct from the libido, attached to ego drives and self-preservation, all the while continuing to wonder about its provenance, and admitting that this could be a desexualized energy. In *The Ego and the Id*, he constructed the hypothesis of a "displaceable energy, which, neutral in itself, can be added to a qualitatively differentiated erotic or destructive impulse, and augment its total cathexis. . . . It seems a plausible view that this displaceable and neutral energy. . . proceeds from the narcissistic store of libido—that it is desexualized Eros" (1923b, p. 41).

Most post-Freudian authors recognize no other psychic energy than the libido, except for the school whose source is *Ego Psychology*, which developed the Freudian idea of a displaceable, neutral energy; for them, this was a "neutralized" energy, participating in the functioning of an ego that had been "liberated from conflicts." With Melanie Klein, the evolution of the stages of the libido was prominent at the beginning of her work; later, the importance accorded to unconscious fantasy and the object relation would force her, in fact, to abandon the economic point of view altogether. On the contrary, the notion of psychic energy and the economic point of view would be very important to the perspective opened up by Pierre Marty and the work of the psychosomaticists of the School of Paris. The notion of the libido and that of psychic energy will be rejected by Jacques Lacan, who replaced the drives with "desire" and spoke ironically of the theory of the libido as an "astral myth"; he allowed absolutely no room for the economic point of view.

PAUL DENIS

*See also:* Binding/unbinding of the instincts; Cathectic energy; Cathexis; Decathexis; Defense mechanisms; Drive/instinct; Economic point of view; Ego; Ego-libido/object-libido; Facilitation; Free energy/bound energy; Fusion/defusion of instincts; Hypercathexis; Libido; Nar-

cissism; Pleasure/unpleasure principle; Primary process/secondary process; Principle of consistency; Process; Return of the repressed; Sum of excitation; Work (as a psychoanalytical notion)

### **Bibliography**

- Applegarth, Adrienne. (1971). Comments on aspects of the theory of psychic energy. *Journal of the American Psychoanalytic Association*, 19, 379–416.
- Freud, Sigmund. (1900a). The interpretation of dreams. Part I, *SE*, 4: 1–338; Part II, *SE*, 5: 339–625.
- . (1923b). The ego and the id. *SE*, 19: 1–66.
- . (1950c [1895]). Project for a scientific psychology. *SE*, 1: 281–387.
- Freud, Sigmund, and Josef Breuer (1895d). Studies in hysteria. *SE*, 2.

---

## **PSYCHIC REALITY**

A concept developed by Freud to denote the level of reality specific to unconscious processes, psychic reality, from an epistemological standpoint, refers to the "object" that psychoanalysis attempts to characterize, understand, and explore.

In *The Interpretation of Dreams* (1900a), the concept referred to the force of reality associated with the subject's internal fantasy life, which could oppose and even dominate perception of external reality; it could, in other words, seem more "real" than reality itself. From the outset the emphasis was on the objective nature of subjectivity, the reality of subjectivity for the psychical apparatus—even at the expense of its relationship to external reality.

The cultural context in which Freud worked tended to devalue or deprecate the character of subjective mental activity and, in particular, unconscious mental activity. He needed to assert the objective character of unconscious psychic entities in the face of opposition that would prefer to relegate them to the realm of the "imaginary" and unreal.

In an article devoted to hysterical paralysis (1893c), Freud had presented the problem of the "objective" nature of hysterical conversion symptoms and their significance. The difference between biological reality, especially in terms of anatomy, and the "psychic" reality expressed by hysterical symptoms prefigured the objective character of the unconscious, as Freud was to

understand it. The nature of symptomatic manifestations—anesthesia, paresthesia, and so on—demonstrated that hysterical patients could not be “malingerers.” Existence of an autonomous realm of psychical life and the unconscious psyche, including the reality of fantasies, could henceforth be asserted with growing confidence.

Another aspect to the emergence of psychical reality was sexual trauma and its value in terms of etiology in the debate around the role of real-life events as opposed to fantasy. The early *neurotica* that Freud developed tended to assign to some “real” traumatic event—childhood sexual seduction, for example—a determinative role in the etiology of hysteria and of neuroses, more generally. However, treatment gradually revealed that it was impossible to say whether the remembered scenes of traumatic seduction had actually taken place or were “invented.” The infantile and sexual fantasies that such scenes represented replaced the traumatic etiology of neurosis. These fantasies, an important type of psychical reality, impacted the psychic apparatus with all the force of “reality” and more.

Thus, the concept of psychical reality was advanced initially to point out the imperious nature of fantasy with its hallucinatory quality, which could somehow dominate external reality. Any trace of opposition between external and internal as the concept is currently employed is complicated further by the question of how to determine the source or basis of the subjectively “real” character of psychical reality.

Two kinds of hypotheses can be advanced in this regard. Not necessarily antagonistic, they represent two major strands in psychoanalytic thought that need to be considered together. The first type relates psychical reality to the impact of external reality, summarized at a preliminary level by the Freudian aphorism, “Nothing in thought that was not first in the senses.” Psychical reality in this sense would indicate a previous encounter with reality; it would represent a reality that has become psychical through trace of impact. The character of reality itself would bear witness to the psychical heritage of encounters with the external world. Fantasies, according to this view, are “hybrid” structures that contain a core of reality, a kind of transformed reminiscence, the source of which lies at a remote point in time. Beyond hallucination, what is actualized and acts upon the psychic apparatus refers to a past reality—for example, cruel acts of childhood retained in feelings of guilt.

The second type of hypothesis relates psychic reality to the constraints intrinsic to psychical activity, to its laws and operational principles. Thus, older representations of desire can be reactivated via the pleasure principle through hallucination, creating the perception of a wish fulfilled, even to the possible detriment of perception of the real world.

However the psychic apparatus develops, do awareness and symbolization of lived experience obey the rhythm and laws specific to psychic reality? Its own requirements cannot be ignored. Constraints are imposed by the external world, while others arise from the psychical apparatus itself. Psychical reality makes demands with the same limitations and categorical imperatives as instincts and external reality. This has led some contemporary psychoanalysts to formulate the existence, alongside the pleasure principle and the reality principle, of a “principle of psychical reality.”

An epistemological point of view would distinguish three types of reality: material reality generally, that aspect of material reality characterized by biological reality, and another aspect, independent of biological reality, to be known as psychical reality. This last is the special province of psychology. Psychoanalysis would be characterized as providing an account of “unconscious psychical reality” and its impact on psychical reality.

The concept of psychical reality thus unfolds in a paradoxical way. It types reality and constrains subjectivity; it indicates the psychical objectivity of the action of subjectivity and its preeminent concern for the intelligibility of psychical facts. These arise not only from the earliest subjective experiences, from what Freud called the “psychic raw material,” but also from the requisite transformation of this material in the course of development, aiming at integration necessary for acceptance at higher levels of consciousness and in consonance with laws that govern there.

RENÉ ROUSSILLON

*See also:* Internal/external reality.

### **Bibliography**

Freud, Sigmund. (1893c). Some points for a comparative study of organic and hysterical motor paralyses. *SE*, 1: 155–172.



———. (1900a). The interpretation of dreams. Parts I and II. *SE*, 4–5.

Roussillon, René. (1995). La métapsychologie des processus et la transitionnalité. *Revue française de psychanalyse*, 59.

### Further Reading

Arlow, Jacob. (1996). The concept of psychic reality—how useful. *International Journal of Psychoanalysis*, 77, 659–666.

Friedman, Lawrence. (1995). Psychic reality in psychoanalytic theory. *International Journal of Psychoanalysis*, 76, 25–28.

Meissner, William W. (2001). Psychic reality in the psychoanalytic process. *Journal of the American Psychoanalytic Association*, 49, 855–890.

## PSYCHIC REPRESENTATIVE

Sigmund Freud used the term *psychic representative*—*psychische Repräsentanz*, the expression of an instinct in mental life—almost synonymously with *Triebrepräsenzanz*, or “instinctual representative.” The distinction seems to be that the latter term emphasizes the thing that is expressed (the instinct), whereas the former emphasizes the process of expression. In fact, this possible discrepancy raises the problem of the instinct as a “frontier-concept” between the psychic and the somatic. Controversies over this point have pit authors who have attempted to dispense with this notion and its uncertainties, such as Jean Laplanche (1987/1989) and Daniel Widlöcher (1986), against others who, like André Green (1995, 1997), have vigorously defended its position within the metapsychological edifice and who attempt to specify its status.

It was in the “metapsychological” articles of 1915 (“Instincts and Their Vicissitudes,” “Repression,” and “The Unconscious”) that Freud posed this question the most clearly, by defining two components of this expression of the somatic in the psyche: the “ideational representative” and the “quota of affect.” However, he had already outlined the issue as early as 1895, in the “Project for a Scientific Psychology,” and above all in *Three Essays on the Theory of Sexuality* (1905), to which he substantially added in 1915 based on his then current thinking. He later reformulated these issues in his second theories of the instincts in *Beyond the Pleasure Principle* (1920) and *The Ego and the Id* (1923).

ROGER PERRON

*See also:* Drive/instinct; Ethology and psychoanalysis; Ideational representative; Instinctual representative; Neurotic defenses; Physical pain/psychical pain; Pictogram; Primal repression; Quantitative/qualitative; Quota of affect; Repressed; Repression; “Repression”; Unconscious fantasy.

### Bibliography

Freud, Sigmund. (1905d). Three essays on the theory of sexuality. *SE*, 7: 123–243.

———. (1915c). Instincts and their vicissitudes. *SE*, 14: 109–140.

———. (1915d). Repression. *SE*, 14: 141–158.

———. (1915e). The unconscious. *SE*, 14: 159–204.

Freud, Sigmund. (1920g). Beyond the pleasure principle. *SE*, 18: 1–64.

———. (1923b). The ego and the id. *SE*, 19: 1–66.

———. (1950c [1895]). Project for a scientific psychology. *SE*, 1: 281–387.

Green, André. (1995). *Propédeutique. La métapsychologie revisitée*. Paris: L’Or d’Atalante.

———. (1997). *Les chaînes d’Éros*. Paris: Odile Jacob.

Laplanche, Jean. (1989). *New foundations for psychoanalysis* (David Macey, Trans.). Oxford: Blackwell. (Original work published in 1987)

Widlöcher, Daniel. (1986). *Métapsychologie du sens*. Paris: Presses Universitaires de France.

## PSYCHIC STRUCTURE

Psychic structure defines the dominant organization of an individual’s mind, manner of establishing relationships, and way of dealing with conflicts. Structure must consequently be seen as a whole. It must also be seen as fundamental, registering its influence at a level deeper than what is apparent in the individual’s personality, character, and manner. It is not innate, however. Individual psychic structure history is combined with hereditary or biological factors, since structure and genetics are not mutually exclusive.

Structure retains a unity and an immutable form, according to Freud in *New Introductory Lectures on Psycho-Analysis* (1933a [1932]), where he compares the ego to a crystal that is formed and also breaks along certain lines. Yet it is not invariable, because it is

a living organization that is constantly adapting, and because it can fail to maintain its equilibrium in certain modes of decompensation.

In effect, components of the dominant conflict—castration anxiety, loss of the object, or problems of identity—simultaneously explain the origins of psychic structure, its points of fragility, and the form of breakdown, through neurosis, depression, or psychosis. Depending on the structure in question, the defenses put into play will take on different meanings while sometimes retaining the same form: projection in the phobic subject is not the same as in the delusional subject. Also, symptoms insufficiently define the psychic structure, according to Jean Bergeret in *La violence et la vie* (Violence and life; 1994). While obsession occurs more frequently in depressed patients, it is also present in many cases of psychosis, where it plays a different role, and it is also capable of becoming dominant in an obsessive structure, just as protest or the demand for vindication can be permanently inscribed in a paranoid structure.

The typical stability of neurotic, psychotic, or perverse structures contrasts with the uncertainty of borderline organizations, where a narcissistic fragility produces a specific type of instability—“unstable states, stable structure,” as Daniel Widlöcher put it in his foreword to Otto Kernberg’s book on borderline conditions. Lastly, psychosomatic breakdown is caused by lack of structure, unless structure is considered at the level of organic function, which is no longer exactly a mental phenomenon.

In all cases, the unity of psychic structure can be defined according to different perspectives, which may converge at various points but do not completely overlap. For example, there are pregenital structures, with their archaic, oral, or anal relational modalities, and genital structures, with their more refined oedipal apprehension of the object. Taken together, these different notions of structure offer a less nosographic, more dynamic approach to the notion of structure, as Maurice Bouvet (1967) explained.

AUGUSTIN JEANNEAU

*See also:* Structural theory.

### **Bibliography**

Bergeret, Jean. (1994). *La violence et la vie*. Paris: Payot.

Bouvet, Maurice. (1967). La clinique psychanalytique: la relation d’objet. In his *Œuvres psychanalytiques*, Vol. 1. Paris: Payot.

Freud, Sigmund. (1933a [1932]). New introductory lectures on psycho-analysis. *SE*, 22: 1–182.

Widlöcher, Daniel. (1979). Preface. In Otto Kernberg, *Les troubles limites de la personnalité*. Toulouse, France: Privat.

### **Further Reading**

Boesky, Dale. (1988). The concept of psychic structure. *Journal of the American Psychoanalytic Association*, 36(S), 113–136.

Loewald, Hans W. (1978). Instinct theory, object relations, and psychic-structure. *Journal of the American Psychoanalytic Association*, 26, 493–506.

Schafer, Roy. (1988). Discussion of panel presentations on psychic structure. *Journal of the American Psychoanalytic Association*, 36(S), 295–312.

---

## **PSYCHIC TEMPORALITY**

The expression “psychic temporality” does not appear as such in the writings of Sigmund Freud. In fact, it is difficult to conceive of any other kind of temporality than psychic temporality, insofar as human time is concerned, whether or not it can be readily represented to the individual subject. Psychoanalytically, psychic temporality may be defined as the way psychic processes create their own time management and sense, according to three possibilities: regression, fixation, and anticipation.

Freud often argued the point that in dreams time is represented through space. He gives the example of a personage, who, in dreams, appears very diminished, as if seen the wrong way through binoculars, a figuration that he interprets not as an estrangement in space, but one in time (1933a [1932]). Reciprocally, the temporal contiguity of the associations of the patient is to be understood as spatial contiguity, recalling in its turn a relation of cause to effect (1905e [1900]). The succession in time of two consecutive dreams can even be upset without altering the causal relation, since it is the respective length of the dreams that then matters (1900a). From all these considerations, it emerges clearly that spatial representation is more important than temporal representation, and allows the latter to be expressed. This is explained by the fact that the visual is the mode of inscription of the infant’s memory.

Fantasy, said Freud, treats chronology with even more indifference, insofar as fantasy “hovers, as it were, between three times—the three moments of time which our ideation involves” (1908e, p. 147). A current impression is necessary, to reawaken an instinctive movement linked to an event from childhood and to create, in imagination, a situation relating to a future when the desire would be realized.

However, in a more general sense, it is the entire psychic life that proudly ignores time. “Neurotics,” wrote Freud, “suffer from obsession or regression” (1912–13a). Whether because it is unaware of the passage of time, or even returns to the past when the present becomes too frustrating, every psychopathological form (hysteria, paranoia, and so forth) takes, in its own way, this flight out of time that is also a flight from reality. Even more profoundly, psychic life combines simultaneously the three forms of topical, temporal, and formal regression found in dreams and in neuroses. Freud writes: “All these three kinds of regression are, however, one at bottom and occur together as a rule; for what is older in time is more primitive in form and in psychical topography lies nearer to the perceptual end” (1900a, p. 548).

Freud noted the total absence of the sense of time in psychosis (1900a), but did not try to explain this. Piera Aulagnier has been concerned with demonstrating the incapacity of the psychotic to conceive of a future time that is not just a pure repetition. She emphasized, on the one hand, the work of auto-historicizing incumbent on the ego, a veritable laying hold of the past and even of the prehistory of the subject; and on the other hand, the identificatory project that allowed the ego, at every moment of its trajectory, to imagine itself in a different place, implying the possibility of change. In psychosis, where repetition dominates, the ego does not succeed in transforming the fragmentary evidence concerning it into a temporal continuity, implying a before and an after. In this regard, the question of identity and the ability to conceive of temporality seem profoundly linked.

SOPHIE DE MIJOLLA-MELLOR

*See also:* *Apprenti-historien et le maître-sorcier (L’-)* [The apprentice historian and the master sorcerer]; Archaic; Autohistorization; Boredom; Castration complex; *Civilization and Its Discontents*; Darwin, Darwinism, and psychoanalysis; Deferred action; Doubt; Ego feeling; Estrangement; Ethnopsychanalysis; Femininity; Forget-

ting; Framework of the psychoanalytic treatment; Free association; Group phenomenon; Historical truth; History and psychoanalysis; Id; Identificatory project; Infantile, the; Kantianism and psychoanalysis; Latency period; Memory; “Metapsychological Supplement to the Theory of Dreams”; Mnemic trace/memory trace; Music and psychoanalysis; Myths; Nirvana; Nostalgia; “Note upon the ‘Mystic Writing Pad’, A”; Phenomenology and psychoanalysis; Prehistory; Primal repression; Primal, the; Processes of development; Proton-pseudos; Psychic causality; Psychotic potential; Regression; Repetition; Screen memory; Self-consciousness; Stage (or phase); Symbolization, process of; *Thalassa. A Theory of Genitality*; “Theme of the Three Caskets, The”; Time; Unconscious, the; Working-through.

### Bibliography

- Aulagnier, Piera. (1984). *L’Apprenti-historien et le maître-sorcier. Du discours identifiant au discours délirant.* (The apprentice historian and the master sorcerer). Paris: Presses Universitaires de France.
- Castoriadis-Aulagnier, Piera. (1975). *La violence de l’interprétation. Du pictogramme à l’énoncé* (The violence of interpretation: from the pictogram to the enunciation). Paris: Presses Universitaires de France.
- Freud, Sigmund. (1900a). The interpretation of dreams. Part I, *SE*, 4: 1–338; Part II, *SE*, 5: 339–625.
- . (1908e). Creative writers and day-dreaming. *SE*, 9: 141–153.
- . (1912–13a). Totem and taboo. *SE*, 13: 1–161.
- . (1933a [1932]). New introductory lectures on psycho-analysis. *SE*, 22: 1–182.

## PSYCHOANALYSE DES NÉVROSES ET DES PSYCHOSES, LA

*La psychoanalyse des névroses et des psychoses* (The psychoanalysis of neuroses and psychoses), by Emmanuel Régis and Angélo Hesnard, was the first book on psychoanalysis ever published in French. Prior to its publication, Freud mentioned it in a letter to Karl Abraham dated January 2, 1912: “Today I received a letter from a pupil of Régis at Bordeaux written on his behalf apologizing in the name of French psychiatry for its neglect of psycho-analysis and announcing his willingness to publish a long paper about it in *Encéphale*” (Freud and Abraham, 1965, p. 111). To Ernest Jones he wrote more specifically twelve days later:

“There is some stir in France even now, another man Hesnard a pupil of Régis at Bordeaux presenting in the name of his master to me ‘the excuses of the French nation’ for so continued a slighting and declaring himself prone to work for  $\Psi$ A [psychoanalysis] in the French papers” (Freud and Jones, 1993, p. 126)

Régis and Hesnard published two articles in *L'encéphale* in April and June 1913 on “the doctrine of Freud and his school” (1913a; 1913b). They were introduced as follows: “Freud’s system, whatever may be said of it, seems to constitute one of the most important scientific movements of our psychological times. Irrespective of whether its renown, now worldwide, is justified or not, we must surely be shocked and rightly so, that this system is almost completely unknown in our country.”

Régis and Hesnard’s book recapitulated and expanded on the two articles. Based on a reading of Freud and written with the collaboration of Oswald Hesnard, Germanist and brother of Angélo, the book presented the basics of Freudian theories as faithfully as possible at the time. The authors were very clear in their preface, dated May 1, 1914: “Possibly some will be shocked to see this popularization of a German theory that is at once so widely endorsed, so contested, and in certain ways so foreign, undertaken by French psychiatrists who are far from partial to the current fashion for German science. There is no cause for surprise, however. It is one thing not to accept blindly whatever comes from outside, another to ignore or misunderstand it. Impartiality and independence regarding what comes from elsewhere should not turn into xenophobia.”

The first part of the work (“The Theory of Psychoanalysis”) has six chapters: “Description and History of Psychoanalysis,” “The Dynamic Psychology of Freud,” “The Sexual Theory of Freud,” “The Morbid Sexual Constitution,” “The Technique of Psychoanalysis, Dream Analysis,” and “The Psychoanalysis of Associations of Ideas and Daily Life” (titles are translated from the French).

The second part (“Applications of Psychoanalysis”) has five chapters: “Extramedical Applications of Psychoanalysis,” “The Psychoanalysis of Neuroses,” “The Psychoanalysis of Psychoses,” “The Therapeutic Role of Psychoanalysis,” and “The Critique of Psychoanalysis.” There followed a bibliography listing the works of Freud, various books and articles in French, and some non-French works on psychoanalysis.

Sándor Ferenczi (1915) quickly recognized the significance of the book, but nevertheless found serious fault in it because it lacked the notion of the unconscious and repeated throughout the error of deriving almost all emotional tendencies from the sexual instinct. Ferenczi also challenged the judgments of the last chapter, which he correctly attributed to Régis. He vigorously stated his objections: the book lacks scientific value; it depends on “mystical concepts” and “teleological conceptions” that are more philosophical than medical; and it bases psychoanalysis on “ingenious hypotheses” and “fragile, uncertain techniques” whose “symbolic interpretation is sometimes an insult to common sense.”

One statement from Régis and Hesnard’s book served as a leitmotif for a good number of authors in the decades that followed: “Freud’s method and conceptions are based on those of Janet, by whom, it seems, he was constantly inspired. Changing Janet’s ‘psychological analysis’ to ‘psychoanalysis’ changed nothing as far as the method common to both students of Charcot was concerned.” For his part, Freud, in his “On the History of the Psychoanalytic Movement” (1914d), merely noted, “Régis and Hesnard (Bordeaux) have recently [in 1913] attempted to disperse the prejudices of their countrymen against the new ideas by an exhaustive presentation, which, however, is not always understanding and takes special exception to symbolism” (p. 32). Freud never forgave Hesnard for his ambivalence, which he let pass only around 1926, and then only partially.

The First World War put an end to any serious discussion in France about psychoanalysis, and hence Régis and Hesnard’s work, until 1920 (an exception being André Breton’s discovery of Freud in 1916). Régis died in 1918, and Hesnard alone was responsible for the new edition of 1922, where he wrote, “Science without scientific nationalism can be neither alive or fruitful. Freud’s teaching, which derives not, as has been claimed, from the French genius of Charcot, but rather from Germanic philosophy could have no more deniable adversary than moderation, a trait of Latin genius, from one point of view of the search for truth.” Freud did not much appreciate this remark, and four years later he spoke sarcastically to René Laforgue about such “bowing and scraping before Latin genius.”

In the third edition, appearing in 1929, Hesnard revealed that the chapter critical of psychoanalysis had been written by Régis, even if Hesnard had agreed at

the time. “At present,” Hesnard added, “with the benefit of five years of daily experience of it, we are in a better position to confirm the great value and significance of psychoanalysis. It is a therapeutic—and especially an exploratory—method that is indisputably superior to all others, in this, despite the drawbacks, it inevitably shares with all ‘heroic treatments.’”

ALAIN DE MIJOLLA

See also: France; Hesnard, Angélo Louis Marie; Régis, Emmanuel Jean-Baptiste Joseph.

### Source Citation

Régis, Emmanuel, and Hesnard, Angélo. (1914). *La psychoanalyse des névroses et des psychoses: Ses applications médicales et extramédicales*. Paris: Alcan.

### Bibliography

- Ferenczi, Sándor. (1915). Die psychiatrische schule von Bordeaux über die psychoanalyse. *Internationale Zeitschrift für Artzliche Psychoanalyse*, 3, 352–369.
- Freud, Sigmund. (1914d). On the history of the psychoanalytic movement. *SE*, 14: 1–66.
- Freud, Sigmund, and Abraham, Karl. (1965). *A psycho-analytic dialogue: The letters of Sigmund Freud and Karl Abraham, 1907–1926* (Bernard Marsh and Hilda C. Abraham, Trans.). New York: Basic Books.
- Freud, Sigmund, and Jones, Ernest. (1993 [1908–1939]). *The complete correspondence of Sigmund Freud and Ernest Jones, 1908–1939*. Cambridge: Harvard University Press.
- Hesnard-Félix, Edith. (1984). *Le Dr. Hesnard et la naissance de la psychanalyse en France*. Doctoral thesis, University of Paris I.
- Régis, Emmanuel, and Hesnard, Angélo. (1913a). La doctrine de Freud et de son école (1re partie). *Encéphale*, 8, 356–378.
- Régis, Emmanuel, and Hesnard, Angélo. (1913b). La doctrine de Freud et de son école (suite et fin). *Encéphale*, 8, 537–564.

## PSYCHOANALYSIS

Sigmund Freud himself provided the most complete, and now most classical definition for his invention, psychoanalysis: “Psycho-analysis is the name (1) of a procedure for investigating mental processes which are

almost inaccessible in any other way, (2) of a method (based upon that investigation) for the treatment of neurotic disorders and (3) of a collection of psychological information obtained along those lines, which is gradually being accumulated into a new scientific discipline” (1923a [1922], p. 235). This definition, intended for the *Encyclopaedia Britannica*, is still widely used today by many psychoanalytic training institutes.

Freud also wrote that the best way to understand psychoanalysis was to study its history. Its origins could be traced to the young Viennese doctor’s medical practice. He frequently treated “nervous” patients, for the most part described as suffering from “hysteria,” a field he came to specialize in after his return from Paris and his work assisting Jean Martin Charcot. He needed to heal these patients and develop a clientele large enough to support his growing family, even though therapeutic procedures at the time were practically nonexistent. The available techniques—electric shock, isolation in medical clinics, and sedatives—were soon abandoned. Hypnosis appeared to him at first to produce miraculous results, but it turned out to be a dead end, and he decided to apply the “cathartic method” that his mentor, Joseph Breuer, had discovered during the treatment of the patient known as Anna O. Taking the symptom as its starting point, this method strove to have the patient recall the circumstances of its first occurrence, and a successful outcome depended on this recollection by means of talk, which was supposed to make the symptom disappear.

Freud then discovered the “resistance” that patients would put up during the search for pathogenic “primal scenes,” as if they wanted to keep the origin of their illness secret. The material that was “repressed” in this way always involved old memories associated with specific events related to the earliest sexual activity of children. His suggestion that such a sexuality even existed greatly shocked many of his contemporaries. His patients soon began drawing his attention to their dreams, which he encouraged them to recount. In keeping with his belief in determinism, Freud concluded that dreams fulfilled a function—the safeguarding of sleep through the fulfillment of wishes that had been ignored by consciousness—and consequently had an “unconscious” content, a meaning that could be deciphered. The analysis of resistance and the interpretation of dreams, together with the method of “free association,” became the pillars of the psy-

chotherapy to which Freud, in 1896, gave the name “psychoanalysis.” The term appeared for the first time in an article written in French, “Heredity and the Aetiology of the Neuroses” (1896a).

By the first years of the twentieth century, the principal features of psychoanalytic treatment that still define it at the beginning of the twenty-first had been established: The patient was placed on a couch and the therapist remained out of sight. The patient was asked to say whatever came to mind. Sessions were fairly long, frequent, and expensive, so that the treatment would become an important part of the patient’s life and so that the bond with the psychoanalyst—the “transference”—would become the principal engine of the attempt to reconstruct the past and weaken the defenses the patient had set up against the pressure from contradictory drives. But the initial therapeutic successes were not as consistent or as long-lasting as Freud had hoped. The transference could become hostile and give rise to a “negative therapeutic reaction,” leading to the discontinuation of treatment or its indefinite extension.

Freud was less a therapist than a researcher, something he often recognized; it was primarily his students and successors who introduced improvements to his methods, or different but connected methods, to make the “therapeutic” aspect of psychoanalysis more effective.

Thus Carl G. Jung and Hermine von Hug-Hellmuth worked with psychotic patients, and Anna Freud and Melanie Klein with children. Otto Rank and Sándor Ferenczi sought to improve psychoanalytic therapy and make it more effective. They introduced so-called “active” techniques and tried to shorten the length of therapy, even exploring a form of “mutual analysis.” Traces of these early initiatives can be found in psychotherapeutic methods developed years later. Similarly, the extension of psychotherapy to patients presenting problems of psychosis or addiction, and the development of group analysis and psychodrama all tended to point up the therapeutic value of psychoanalysis. Some psychoanalysts sought to render their approach more effective by forging links with the neurosciences.

Following Freud, however, who quipped about the profession’s “*furor sanandi*,” other psychoanalysts emphasized the research implications of treatment. Thus Jacques Lacan, who in 1957 spoke of curing patients as merely an “extra” benefit of psychoanalysis, and who in 1964, when he founded the *École freudi-*

*enne de Paris*, described training analysis as “pure”—as opposed to simply “therapeutic”—psychoanalysis, clearly represents the tendency that embraces the third of Freud’s three basic definitions of psychoanalysis.

In his daily practice, however, Freud never differentiated between what he experienced and what he theorized later. His letters to Wilhelm Fliess allow us to follow, almost day by day, the theory-building that turned psychoanalysis into the “depth psychology” Freud hoped would supplant academic psychology. A work of construction then—but also of deconstruction—Freud considered his ideas to be superstructures whose existence was necessarily ephemeral, and anticipated new discoveries better adapted to the knowledge obtained from clinical practice. A first model, developed in 1900, which described a psychic apparatus formed of three agencies—the unconscious, preconscious, and conscious—was replaced in 1923 by another conceptual scheme comprising the id, the ego, and the superego. And while Freud remained firmly committed to the Oedipus complex, he had, over a period of forty years of work, fleshed out the speculative aspects of his metapsychology with new concepts that improved and sometimes reversed his earlier hypotheses: narcissism, the death instinct, the phallic stage, the splitting of the ego.

Alfred Adler, in 1911, and Jung, in 1913, made their final breaks with Freud over theoretical disagreements and formed their own schools. The first psychoanalytic theory to be developed that broke with Freud’s theories while also claiming to further the Freudian tradition was Melanie Klein’s, developed between 1930 and 1962. Klein radically revised the Freudian view of the first moments of the formation of the mental apparatus, on the basis of her clinical experience with very young children and her interest in psychoses. Her theoretical model invoked very early stages she referred to as “depressive” or “paranoid-schizoid” positions, and she held that the Oedipus complex originated at a much earlier age than Freud thought. Her opposition to Anna Freud, who insisted on strict fidelity to the spirit and letter of her father’s theories, gave rise to several important “controversies” (1941–1945) that determined the orientation of the British Psycho-Analytical Society after the Second World War. Following Klein, Donald Winnicott, Wilfred Bion, and Ronald Fairbairn helped develop British psychoanalytical theory and practice. In the United States a number of derivative psychoanalytic theories came into being,

some of which parted ways with classical Freudian theory. The theory of ego-psychology was introduced by Heinz Hartmann, Ernst Kris, and Rudolph Loewenstein, and was for years the major reference point of American psychoanalysis. Heinz Kohut developed a theory of narcissism, and Karen Horney and Harry Stack Sullivan were cofounders of a “culturalist” approach. Erik Erikson’s work was also notable.

In France, Jacques Lacan, under the banner of the “return to Freud” in November 1955, proposed new models that in his view could better account for the constitution of the “subject” and the relationship between the subject and the unconscious. The three categories of the real, the imaginary, and the symbolic; the primacy of the phallus; the object *a*; Borromean knots; and mathemes were so many milestones in an evolving theory that Lacan developed week by week, from 1954 to 1981, in his famous seminars. His idiosyncratic use of the findings of modern linguistics, inspired by Ferdinand de Saussure, of structuralism, and of logical and mathematical models, enabled him to make an audience of even communities like the Catholic Church and the Marxist orthodoxy, which had previously rejected “Freudian doctrine” as “unscientific.”

Whether or not psychoanalysis is a science has been debated for years, and the issue reappears regularly in the news. For epistemologists like Karl Popper and a host of other critics, the statements made by psychoanalysis cannot be considered scientific since they cannot be “falsified” and because the theory cannot be “refuted.” For Freud, the scientific status of his theory was never in doubt, and he considered his metapsychological hypotheses no more implausible than those of contemporary physics. Psychoanalysis, as far as he was concerned, was a “natural science” (“*Naturwissenschaft*”). Despite holding a position deemed by some close to “scientism,” Freud clearly distinguished his belief in a scientific ideal and the consistency of his hypotheses concerning the unconscious from a *Weltanschauung*, a “vision of the world” whose totalizing tendencies and illusory nature he feared. In *The Question of Lay Analysis*, he wrote: “Science, as you know, is not a revelation; long after its beginnings it still lacks the attributes of definiteness, immutability and infallibility for which human thought so deeply longs. But such as it is, it is all that we can have” (1926e, p. 191).

Freud also insisted on the importance of psychoanalysis as a cultural phenomenon and a special instrument for studying and understanding other cul-

tural phenomena. On July 5, 1910, he wrote to Jung: “I am becoming more and more convinced of the cultural value of psychoanalysis, and I long for the lucid mind that will draw from it the justified inferences for philosophy and sociology” (p. 340).

His letters to Wilhelm Fliess already illustrate the extent to which his psychological discoveries provided new insights for the understanding of literature and visual art, and how their study provided him with new ideas or proofs of the correctness of his views. It was Sophocles who provided Freud with the name for his “Oedipus complex,” discovered during his self-analysis in October 1897. In 1913 he indicated the fields of knowledge he felt would benefit (1913j) from psychoanalytic concepts. Aside from psychology, he listed the science of language, philosophy, biology, the history of the development of civilization, aesthetics, sociology, and pedagogy.

He confirmed this interaction in the *Introductory Lectures on Psychoanalysis*: “In the work of psychoanalysis links are formed with numbers of other mental sciences, the investigation of which promises results of the greatest value: links with mythology and philology, with folklore, with social psychology and the theory of religion. You will not be surprised to hear that a periodical has grown up on psychoanalytic soil whose sole aim is to foster these links. This periodical is known as *Imago*, founded in 1912 and edited by Hanns Sachs and Otto Rank. In all these links the share of psychoanalysis is in the first instance that of giver and only to a less extent that of receiver” (1916–1917a, p. 167–68).

Despite the charge that Freudian concepts cannot be applied outside the framework of the treatment and notwithstanding the superficial way they have indeed too often sometimes been used, the fact is that “applied psychoanalysis” has profoundly modified our view of literature and the fine arts, of biography, and of sociological and political realities. Freud set the example by the way he approached Wilhelm Jensen’s story “Gradiva,” Leonardo da Vinci’s life, and Michelangelo’s sculpture, to mention only a few of his contributions. But on several occasions he expressed his reservations about the value of the psychobiographies produced by some of his followers and successors.

Toward the end of his life his clinical work took a secondary position to his writings on the great problems of religion and culture: *The Future of an Illusion* (1927c), *Civilization and Its Discontents* (1930a

[1929]), and especially his last work, *Moses and Monotheism* (1939a [1934–1938]), which expands upon the anthropological ideas he had extensively covered in *Totem and Taboo* (1912–13a).

Later, the spread of Freudian ideas attracted the interest of writers, artists, and critics, who made use of them to enrich their own work. The Surrealists were among the first, but novelists, painters, and dramatists borrowed from psychoanalysis as well. Created at the same time as cinematography, psychoanalysis has inspired filmmakers from the early days. One has only to think of *Secrets of a Soul* (*Geheimnisse einer Seele*), the film G. W. Pabst made in 1926 in spite of Freud's reservations; or of the films of Alfred Hitchcock, *Spellbound* and *Vertigo*; or of *Freud, the Secret Passion*, by John Huston, prepared with the help of Jean-Paul Sartre and released in 1962, in which Montgomery Clift plays the role of Freud; or, for that matter, of the comic treatment of psychoanalysis by Woody Allen.

Throughout the twentieth century, the discoveries of psychoanalysis and its theory of the unconscious have profoundly modified the rules mankind has established concerning its behavior and sexual taboos, its relation to guilt, to femininity, and more generally to other people, about whom a whole new unconscious aspect was now apprehended. Obviously, however, the wide dissemination and renown of psychoanalysis were themselves the product of the twentieth century. Psychoanalysis was inspired and carried along by that century, with its excesses, its political ideologies, its economic and religious ups and downs, and above all, its terrible conflicts, which despite all claims to civilized behavior mobilized the darkest and most barbaric of human impulses just as Freud had understood and feared (1915b, 1933b [1932]).

In so many ways—the liberalization of behavior, the advancement of the status of women (both inside and outside feminist movements and in spite of their virulent criticisms of Freudianism), the dawning recognition of sexual minorities (even though in Freudian theory their preferences have been explained as arrested libidinal development and more or less archaic fixations), a different approach to the subject and its relation to itself and the other—psychoanalysis has become a part of everyday life throughout the so-called “Western” world and is not about to simply disappear, despite all the wild swings of fashion.

Its expansion toward other cultural sensibilities, like the multiplication of the often contradictory theories

and techniques that claim allegiance to it, as demonstrated by this *Dictionary*, show that psychoanalysis has never been a dogma or the kind of closed theory caricatured by dishonest critics. In his own time Freud defined those “cornerstones,” which seemed to him to provide the foundation that his successors would trace back to him: “The assumption that there are unconscious mental processes, the recognition of the theory of resistance and repression, the appreciation of the importance of sexuality and of the Oedipus complex—these constitute the principal subject-matter of psycho-analysis and the foundations of its theory. No one who cannot accept them all should count himself a psycho-analyst” (1923a [1922], p. 247). Nothing has really changed regarding the basic principles, in spite of the considerable diversity found in theoretical research and methods of practice, which has enriched the great network of the global psychoanalytic movement.

The recent rapid development of the neurosciences does not signal any decline in the value of the listening procedure that psychoanalysis has offered for more than a century in its attempt to understand and treat mental suffering. Apparently contradictory theoretical systems will eventually intersect and enrich each other, and the pessimism of the Cassandras can be answered with Freud's remarks, written in 1914: “At least a dozen times in recent years, in reports of the proceedings of certain congresses and scientific bodies or in reviews of certain publications, I have read that now psychoanalysis is dead, defeated and disposed of once and for all. The best answer to all this would be in the terms of Mark Twain's telegram to the newspaper which had falsely published news of his death: ‘Report of my death is grossly exaggerated’” (1914d, p. 35).

ALAIN DE MIJOLLA

### **Bibliography**

- Freud, Sigmund. (1912–13a). Totem and taboo. *SE*, 13: 1–161.
- . (1913j). The claims of psycho-analysis to scientific interest. *SE*, 13: 163–190.
- . (1915b). Thoughts for the times on war and death. *SE*, 14: 273–300.
- . (1916–17a [1915–17]). Introductory lectures on psycho-analysis. Parts I and II. *SE*, 15–16.
- . (1923a [1922]). Two encyclopaedia articles. Psycho-analysis. *SE*, 18: 234–255.



———. (1926e). The question of lay analysis. *SE*, 20: 177–250.

———. (1930a [1929]). Civilization and its discontents. *SE*, 21: 57–145.

———. (1933b [1932]). Why war? (Einstein and Freud). *SE*, 22: 195–215.

———. (1939a [1934–38]). Moses and monotheism: Three essays. *SE*, 23: 1–137.

Freud, Sigmund, and Jung, Carl. (1974a [1906–13]). *The Freud/Jung letters: The correspondence between Sigmund Freud and C. G. Jung* (William McGuire, Ed., and Ralph Manheim and R.F.C. Hull, Trans.). Princeton, NJ: Princeton University Press.

Mijolla, Alain de. (1996). Psychoanalysts and their history. *International Psychoanalysis: The Newsletter of the IPA*, 5 (1), 25–28.

## PSYCHOANALYSIS OF CHILDREN, THE

Melanie Klein's first work, this book is the thoroughly worked-out result of her substantial clinical experience in applying psychoanalytic treatment to children. Though there had been other attempts to use psychoanalysis in treating children, notably Sigmund Freud's work with the father of Little Hans, reported in "Analysis of a Phobia in a Five-Year-Old Boy" (1909), *The Psychoanalysis of Children* is free of adult-centered biases and is a pioneering work.

Klein's freedom of thought, in terms first of technique and then of theory, came from her discovery of a new methodology: the use of the play technique had opened a new field of investigation of the unconscious. She had observed that children's play expressed their fantasies and anxieties. Gradually, she realized that children's play could be situated within the framework of the ego's attempts to defend itself from instinctual conflicts in order to work them out. This led to her conception of symbolism, a psychic mechanism that is essential for development of the ego.

This book can be divided into two parts. The first and technical part is based on six lectures given by Klein in London at the invitation of Ernest Jones in 1925 and 1927. In these chapters, Klein emphasized the clinical signs indicative of children's transference fantasies, which, in her view, made it possible to interpret them in a way that was similar to analytic work with adults. In fact, she demonstrated the technical value of an early interpretation of the transference resistances of certain children, in order to facilitate the

establishment of the therapeutic bond and a psychoanalytic process.

The second, more theoretical part of the book was written later. Here Klein developed her ideas on the early stages of the Oedipus complex, manifested in the phase of maximum sadism, where the child's aggressive instincts are directed toward parental part-objects: the mother's breast, the father's penis, and in particular the mother's body and its contents. Fixations of this kind can produce hypochondriacal fantasies about the child's own body, or else various inhibitions, especially in relation to toilet training. In Klein's conception, the early forms of the superego result from introjection of the persecutory breast and penis, which function as internal persecutors.

In this work Klein gradually became more oriented toward a theory of psychic conflict in which aggression plays the greatest role. The destructive omnipotence of aggressive fantasies stems from the child's immaturity in his or her struggle against the death instinct, as Klein argued in greater detail in her later theoretical work.

FRANCISCO PALACIO ESPASA

See also: British Psycho-Analytical Society; Childhood; Oedipus complex, early; Richard, case of; Technique with children, psychoanalytic.

### Source Citation

Klein, Melanie. (1932). *Die psychoanalyse des Kindes*. Vienna: Internationaler Psychoanalytischer Verlag; (1975). *The psycho-analysis of children* (Alix Strachey, Trans., and H. A. Thorner, Rev.). London: Hogarth.

### Bibliography

Freud, Sigmund. (1909b). Analysis of a phobia in a five-year-old boy. *SE*, 10: 1–149.

## PSYCHOANALYSIS OF DREAMS, THE

In 1940, in order to obtain the equivalent, in Argentina, of his medical degree from the University of Madrid, Angel Garma presented his book, *Psicoanálisis de los sueños*, for his doctoral thesis. Considered a classic of psychoanalytic literature, this work has gone through a number of editions in which Garma

has gradually elaborated upon his differences from the Freudian interpretation of dreams as wish fulfillments.

According to Garma, the dreamer's thoughts, originating in repressed content, present hallucinatory characteristics. In becoming conscious, these thoughts inform the manifest dream. They are related to highly traumatic psychic content. The ego seeks to protect itself by masking such contents. It transforms them into what appear to be wish fulfillments, but which are in fact satisfactions more characteristic of mania.

This theory maintains that the traumatic situation that causes dreams ends up as a hallucination when the charge of the repressed content is stronger than the weakened counter-charge of the sleeping ego. These contents give the ego the impression that they correspond to current situations in the real world. In Garma's view this is a phenomenon that occurs in a way diametrically opposed to that described by Freud describes it in his theory of reality-testing.

GILDA SABSAY FOKS

See also: Argentina; Garma, Angel.

### Source Citation

Garma, Angel (1940). *Psicoanálisis de los sueños*. Buenos Aires: El Ateneo; (1985). *The psychoanalysis of dreams*. New York: Jason Aronson.

### Bibliography

Garma, Angel (1970). *Neuvas aportaciones al psicoanálisis de los sueños*. Buenos Aires: Paidós.

---

## PSYCHOANALYSIS OF FIRE, THE

*The Psychoanalysis of Fire* was published by Gaston Bachelard in 1938, before *Water and Dreams: An Essay on the Imagination of Matter* (1940), *Air and Dreams: An Essay on the Imagination of Movement* (1942), and *Earth and Reveries of Will* (1945). This essay was part of an effort that reconnected research on pre-Socratic philosophy with the question of the fundamental constituents of the world, the "elements."

Bachelard was both a theoretician of modern science (*The New Scientific Spirit*, [1934]; *Le Rationalisme appliqué*, [1949]) and a philosopher of poetics,

in the sense that while demonstrating the need for systematization associated with all rational thought, he insisted on the collapse of any system in the face of the infinite richness of experience. He also attempted to circumscribe existence with a profound imagination imbued with poetic experience that transcends the individual imagination of the subject.

For Bachelard the phenomenon of fire is situated at this crossroads of science and poetry. In his preface, he writes, "I am going to examine a problem in which objectivity has never held sway, where the initial seduction is so compelling that it deforms the most rational minds and leads them to the cradle of poetry, where daydreams replace thought, where poems hide theorems. This is the psychological problem presented by our convictions about fire. The problem is so directly psychological that I have no hesitation in speaking of a 'psychoanalysis of fire.'"

The work is broken down into seven chapters: 1. Fire and Respect: The Prometheus Complex; 2. Fire and Reverie: The Empedocles Complex; 3. Psychoanalysis and Prehistory: The Novalis Complex; 4. Sexualized Fire; 5. The Chemistry of Fire: History of a False Problem; 6. Alcohol and Water that Flames. Punch: The Hoffmann Complex. Spontaneous Combustions; 7. Idealized Fire: Fire and Purity. The two chapters that most directly concern psychoanalysis are obviously chapters three and four.

It is interesting that Bachelard, who here attempts an anthropological study of the birth of fire in human history and an approach to the libidinal components represented by fire, quotes Carl Jung on several occasions but never Sigmund Freud. He also quotes James George Frazer's *Myths on the Origin of Fire*, even though Freud himself referred to Frazer's work (in 1911 Freud read *The Golden Bough*), which was partly responsible for his interest in prehistory.

We also know that in 1930, in *Civilization and Its Discontents* (1930a [1929]), Freud discussed his famous hypothesis on the origins of the mastery of fire associated with a rejection of the impulse to urinate on the flame to extinguish it: "It is as though primal man had the habit, when he came in contact with fire, of satisfying an infantile desire connected with it, by putting it out with a stream of his urine. . . . The first person to renounce this desire and spare the fire was able to carry it off with him and subdue it to his own use" He also wrote an entire article on this, "The Acquisition and

Control of Fire” (1932a [1931]), in which he provides a brilliant analysis of the myth of Prometheus.

Therefore, the lack of any reference to Freud in Bachelard’s text is surprising, for the direction of their thought converges at many points even though it arises from different epistemological viewpoints. As far as we know Freud never met Bachelard, an existential non-event that may characterize, in its own way, Freud’s profound ambivalence toward philosophy, even when it was highly compatible or consistent with metapsychology.

BERNARD GOLSE

*See also:* Applied psychoanalysis and the interactions of psychoanalysis; Bachelard, Gaston.

### Source Citation

Bachelard, Gaston. (1938). *The psychoanalysis of fire*. (Alan C. M. Ross, Trans.). Boston: Beacon Press [1964].

### Bibliography

Freud, Sigmund. (1930a [1929]). Civilization and its discontents. *SE*, 21: 57–145.

——— (1932a [1931]). The acquisition and control of fire. *SE*, 22: 183–193.

---

## PSYCHOANALYST

“Whoever has admitted that transference and resistance constitute the linchpins of treatment forever belongs in our untamed horde,” Freud wrote to Georg Groddeck on June 15th, 1917. He would later add: “The acceptance of unconscious psychical processes, the acknowledgement of the doctrine on resistance and repression, the taking into consideration of sexuality and the Oedipus complex are the principle tenets of psychoanalysis and the bases of its history, and whosoever is not prepared to subscribe to all of them should not count himself among Psychoanalysts” (1923a).

Since then, disputes have run to the heart of the various psychoanalytic institutes over didactic analyses and training. The absence of a consistent code, compounded by inconsistent statutory regulations which governmental authorities have and have not have enacted in different region, has further multiplied the number of pronouncements as to what each institute reckons should best define what a psychoanalyst is.

Freud had already stated a few of his own prescriptions: “It is therefore reasonable to expect of an analyst, as a part of his qualifications, a considerable degree of mental normality and correctness. In addition, he must possess some kind of superiority, so that in certain analytic situations he can act as a model for his patient and in others as a teacher. And finally we must not forget that the analytic relationship is based on a love of truth—that is, on a recognition of reality—and that it precludes any kind of sham or deceit” (1937c, p. 248).

The work of the psychoanalyst has been described as being quite similar to that of the patient. First of all he or she should be committed to the relationship and to analyzing his or her own motivations for being in it. He or she must also engage in interpretive listening, including to the manifestations of their own defenses. In short, a “free-floating” or “evenly-suspended” attention must be paid when dealing with the processes inevitably evoked or generated by the highly-charged affective moments to which psychoanalytic activity leads.

The term counter-transference has been considerably expanded upon since it first appeared in 1910, and the various meanings attributed to it attest to the intricacies that develop within the analytic situation (Sandler, Joseph, et al., 1973; Blum, Howard, 1986). These conceptual responses, like the so-called “neutrality” intended to make the analyst into a “mirror,” attest to the receptiveness with which personal analysis, often called a “didactic” or “training analysis,” was meant to equip the psychoanalyst. In the event, only a presumptive judgment may be made in this respect. It should be recalled that language is the analyst’s fundamental operation medium. The psychoanalytic candidate must have mastered the unique system of language that a psychoanalytic dialogue will engage him in, as this language is far from being something that unfolds through one voice alone.

The “Rules and Procedures of the Training Committee, Representing the French SPP [Société psychanalytique de Paris],” composed in France in 1949, in which the style of Jacques Lacan is very much in evidence, detailed the criteria for the selection of candidates for apprenticeship in psychoanalysis in France in the wake of the Second World War: “Only through clinical examination may light be shed upon the deficiencies which disqualify the candidate as an aide to memory or judgment: traits pointing to future intel-

lectual frailty, latent psychoses, cognitive difficulties compensated for otherwise; or as a guiding agent: psychical difficulties in the form of crises and mood swings including epilepsy, meaning Cyclothymia.”

The “Rules and Procedures” also advise: “Among other disqualifying elements should be included such problems as might impair the basis of imaginary support the person of the analyst may furnish to transferential identifications in the generic homeomorphism of his body image: shocking deformities, visible mutilations and overt functional impairments . . . Secondly, the examiner should consider the candidate’s cultural education, which is evidenced in the special kind of intellectual open-mindedness that grasps the meanings of words and inspires their usage.”

Freud, relying less on specifics and caricatures in his catalogue of counter-indications, emphasized above all the characteristic element of commitment to the activity, which “cannot well be handled like a pair of glasses that one puts on for reading and takes off when one goes for a walk. As a rule, psycho-analysis possesses a doctor either entirely or not at all” (1933a, p. 153). The arguments that have taken place surrounding whether it is possible to practice psychoanalysis part-time, on the margins of other medical or university activities, are extensive.

While Freud regretted the fact that “It cannot be disputed that analysts in their own personalities have not invariably come up to the standard of psychical normality to which they wish to educate their patients” (1937c, p. 247), he also added: “It almost looks as if analysis were the third of those ‘impossible’ professions in which one can be sure beforehand of achieving unsatisfying results. The other two, which have been known much longer, are education and government” (p. 248).

ALAIN DE MIJOLLA

*See also:* Abstinence/rule of abstinence; Active technique; Analysand; Boundary violations; *Collected Papers on Schizophrenia and Related Subjects*; Counter-transference; Cure; Elasticity; Ethics; Evenly-suspended attention; Face-to-face situation; Framework of the psychoanalytic treatment; Fundamental rule; Initial interview(s); Interpretation; Lay analysis; Money and the psychoanalytic treatment; Mutual analysis; Negative therapeutic reaction; Neutrality/benevolent neutrality; Pass, the; Psychoanalysis; Psychoanalytic technique with adults;

Psychoanalytic technique with children; Psychoanalytic treatment; Psychotherapy; “Recommendations to Physicians Practicing Psychoanalysis”; Supervised analysis (control case); Tact; Termination of treatment; Therapeutic alliance; Training of the psychoanalyst.

### **Bibliography**

- Blum, Howard P. (1986). Countertransference and the theory of technique: discussion. *Journal of the American Psychoanalytical Association*, 34.
- Freud, Sigmund. (1923a [1922]). Encyclopaedia article: “The libido theory.” *SE*, 18: 255–259.
- . (1933a [1932]). New introductory lectures on psycho-analysis. *SE*, 22: 1–182.
- . (1937c). Analysis terminable and interminable. *SE*, 23: 209–253.
- . (1960a). *Letters of Sigmund Freud*. (Ernst L. Freud, Ed.; Tania and James Stern, Trans.) New York: Basic Books.
- Revue française de psychanalyse*. (1949). Règlement et doctrine de la Commission de l’enseignement déléguée par la S.P.P., Paris, France. 13, (3), 426–435.
- Sandler, Joseph; Dare, Christopher; and Holder, Alex. (1973). *The patient and the analyst: the basis of psychoanalytic practice*. New York: International Universities Press.

### **Further Reading**

- Litowitz, Bonnie, et al. (2003). The contemporary psychoanalyst at work. *Journal of the American Psychoanalytic Association*, 51, 9–24.

---

## **PSYCHOANALYTIC EPISTEMOLOGY**

The notion of psychoanalytic epistemology incorporates the epistemology specific to psychoanalytic knowledge as well as the psychoanalysis of mental processes required in the construction of knowledge.

Epistemology refers to the critical examination and logical analysis of scientific knowledge. Traditionally viewed in France as the philosophy and history of science, epistemology is distinguished from the theory of knowledge, which also includes non-scientific knowledge. This distinction is not found in Anglo-American philosophy and, as a result, epistemology is frequently confused with the theory of knowledge, Freud’s *Erkenntnistheorie*. More recently, the concept of genetic epistemology (Jean Piaget) introduced the

analysis of the mental processes of knowledge within a developmental perspective.

The term “epistemology” is fairly recent. It was introduced in France at the beginning of the twentieth century, at the time when the relationship between philosophy and the sciences was reversed: it was no longer philosophy that lent its stature to science but science that became an object of philosophical study. This change in perspective reflected a crisis that had two sources: first, the foundations of mathematics and physics were being called into question by the scientific community itself; and second, the claims of philosophical systems, in particular Hegelian systems, of being able to account for rationality without the need for practical applications or experiential data were being discredited.

The concept of epistemology does not appear in the index to the *Gesammelte Werke*, and the *Concordance to the Standard Edition of the Complete Works of Sigmund Freud* indicates only three occurrences of the term “epistemological” in the *Standard Edition*, where it appears as a translation of the adjective *erkenntnistheoretisch*. The word appears for the first time in the English translation of the obituary of Viktor Tausk. Freud wrote in 1919: “These writings exhibit plainly the philosophical training which the author was able so happily to combine with the exact methods of science. His strong need to establish things on a philosophical foundation and to achieve epistemological clarity compelled him to formulate, and seek as well to master, the whole profundity and comprehensive meaning of the very difficult problems involved” (1919f, p. 274). But the use of the term “epistemological” in the English and French translations obliterates the distinction between “epistemology” and “theory of knowledge.” Yet Freud’s judgment of Tausk can only be fully appreciated when viewed as re-establishing this distinction. It is not, as the translations state, “epistemological clarity” that Freud reproaches Tausk for, but his overestimation of the logico-deductive operations of philosophy. Tausk went too far in trying to prematurely establish psychoanalysis on the basis of a theoretical system that was philosophical in its need for coherence.

Although the term “epistemology” is rarely found in Freud, a Freudian epistemology is nonetheless present. For Freud the epistemic identity of psychoanalysis remained that of the empirical sciences of his time, which are unrelated to the sciences of mind. He relies on observation and inductive logic to rebuff the

demons of metaphysics and goes so far as to claim for psychoanalysis a “specific right to become the spokesman” for the vision of the scientific world. He defends the ideal of science against anarchist and nihilist doctrines that contested the criteria of truth found in scientific knowledge. Psychoanalysis was said to possess the heuristic means to show that science required a determined attitude that rejected “wish fulfillment” through acceptance of observation and methodically programmed experiment, the only path capable of leading us to a true knowledge of reality. He wrote, “it would be illegitimate and highly inexpedient to allow these demands [wish fulfillments] to be transferred to the sphere of knowledge. For this would be to lay open the paths which lead to psychosis, whether to individual or group psychosis. . . .” (1933a., p. 160).

In Freudian discourse the scientific ideal assumes the function of a regulatory idea and barrier for knowledge in general and psychoanalytic knowledge in particular. Freud’s rationalism and positivism were consequently subverted by his discovery: by taking as its subject the gaps, contradictions, and distortions of our mechanisms of observation, language, and reason, psychoanalysis reveals what the constructions of positivist science owe to repression. In keeping with his discovery Freud recognized the anticipatory role of art and philosophy, acknowledged the historical truth of religion, and affirmed the mythopoetic element in every scientific theory. His literary style, his references to historical, philological, and ethnographic works, his interest in Moses and Shakespeare, his sense of doubt concerning thought transference, all temper the image of a realist and positivist Freud. Freud’s psychoanalytic epistemology presents the paradox, analyzed by Paul-Laurent Assoun, of sabotaging the language of science while claiming it as one’s own.

The path of Freudian discovery traces the passage from a therapeutic technique to an *episteme* through the implementation of a method employed within the context of a specific practice. Psychoanalytic epistemology appeared to be essential as much to define and circumscribe the conditions and legitimacy of his approach as it did to respond to the epistemological criticisms to which it was subject. In both cases it is a matter of relating and analyzing whatever is resistant to his method. The criticisms of Karl Popper, Ludwig Wittgenstein, and Adolf Grünbaum cast doubt on the psychoanalyst to the extent that they reveal the risk

psychoanalysis runs whenever it tends to transform itself into an ideology. Yet such objections have the merit of constraining the psychoanalyst to treat his concepts dialectically and be more attentive to precisely defining their use value within a specific framework. Such criticisms also indirectly reveal the limitations of the phenomenological, doctrinal, and hermeneutic revisionism of men like Ludwig Binswanger, Roland Dalbiez, or even Paul Ricoeur, for trying to save psychoanalysis by means of auxiliary hypotheses. For such thinkers, psychoanalysis could only confirm its results by borrowing from other fields of knowledge (phenomenology or neuroscience, for example) or through the addition of extraneous methods (such as surveys or experimental protocols).

Quite the contrary. It is by repatriating the value and scope of discoveries where they originate—the psychoanalytic situation—that psychoanalysis can verify the consistency of its theorizations. Psychoanalysis does not consist of the analyst's knowledge of the analysand's unconscious or a grid for reading the world, but is based on a transsubjective knowledge created as much as revealed by a particular situation of interactive dialogue whose transference and analysis are operators. Outside that field it loses all epistemological validity.

Such methodological operationalism enables psychoanalysis to participate in the ongoing epistemological debate, which tends to reject the ideal of accuracy for a concern for truth that is conceived as revelation as well as creation.

ROLAND GORI

*See also:* Determinism; Gressot, Michel; *Learning from Experience*; Psychoanalytic research; Science and psychoanalysis.

### **Bibliography**

- Assoun, Paul-Laurent. (1981). *Introduction à l'épistémologie freudienne*. Paris: Payot.
- Freud, Sigmund. (1913j). The claims of psycho-analysis to scientific interest. *SE*, 13: 163–190.
- . (1927c). The future of an illusion. *SE*, 21: 1–56.
- . (1933a [1932]). New introductory lectures on psycho-analysis. *SE*, 22: 1–182.
- Gori, Roland. (1996). *La Preuve par la parole. Sur la causalité en psychanalyse* Paris: Presses Universitaires de France.

### **Further Reading**

- Kulish, Nancy. (2002). The psychoanalytic method from an epistemological viewpoint. *International Journal of Psychoanalysis*, 83, 491–495.
- Orange, Donna. (1995). *Emotional understanding. Studies in psychoanalytic epistemology*. New York: Guilford Press
- Strenger, Carlo. (1991). *Between hermenutics and science: An essay on the epistemology of psychoanalysis*. Madison, CT: International Universities Press.

---

## **PSYCHOANALYTIC FAMILY THERAPY**

Psychoanalytic family therapy is based on the observation that for any group that calls itself a family in a given culture, there is an objective interdependence between the subjects comprising it, owing to the hierarchy of generations and the distribution of roles within it. There are also areas of subjective interdependence.

Difficulties concerning the treatment of some patients led therapists to become interested in these individuals' families, which were viewed as pathogenic; the family and the mental patient were examined as a whole, and their specific modes of functioning highlighted. In the 1950s, researchers at Stanford, influenced by systems theory (Ludwig von Bertalanffy), described the kinds of communication that occur in the families of schizophrenics. From this arose a vast area of research that came to be applied to "systematic family therapies."

Concurrently, research on groups was conducted in the field of psychosociology (Jacob-Levi Moreno) and from a psychoanalytic perspective (Sigmund H. Foulkes, Wilfred Bion, Henry Ezriel). In France, Jean-Bertrand Pontalis, Didier Anzieu, and René Kaës proposed new concepts such as the group mind, inter-fantasizing, and group transference.

Family groups whose members had a life in common, both past and present, have been the object of a number of specific experiments conducted by psychoanalysts. Freud suggested the concept of "psychic apparatus" to account for the existence of mental factors associated with this apparatus's ability to distribute and transform psychic energy. Borrowing this model, René Kaës forged the concept of "group psychic apparatus," which he defined as "an efficacious and transitional fiction—that of a psychic group,

backed up by a mythical group, which is seeking to become real by the construction of a concrete group.”

In this connection, family therapists conceptualized a family group mental apparatus, one which originated archaically in the individual psychic “deposits” and the psychic contents of the transgenerational heritage. Their fusion created an unconscious psychic basis, common to members of the family group, inducing a specific experience of belonging, with “a feeling of familiarity,” unlike anything else. Individual fantasies were articulated on this psychic basis, from which they derive some of their content. The family psychic apparatus (FPA) is a conflicting co-construction formed from the elements of internal group feeling of each family member, and elements of a common psyche and of the social group. The FPA, as a category, includes the sexual nature of the roles active in family relations.

In therapy, this psychic organization of the family group is realized within the framework proposed by the therapist. The therapist ensures psychic security, allowing the deployment of the therapeutic process through the free verbalization required, the stability of temporal-spatial conditions, the fact that the duration of the cure is not determined *a priori*, and the rule of abstinence. In their observations and interventions therapists focus especially on group aspects as based on the transference/counter-transference. The essential goal of therapeutic work lies on the level of the paradoxical narcissism-antinarcissism duality that is active from the very beginning in each subject and primal component of the familial psychic apparatus. This objective transcends the treatment of the symptomatology of the “designated patient.” The goal is autonomy for the individual psyche and access to the oedipal conflict, through a sufficient development of the couple/group tension that is always conspicuous within the family group. However, René Kaës has expressed doubts about the “accepted name, Analytical Family Therapy,” thinking it should rather be known as “Psychoanalytical Psychotherapy of the Family.”

Family therapy requires preliminary work to allow the family group to accept this unusual situation. Maurice Berger developed a “new theoretico-clinical field,” in which reference to the group and to psychoanalysis was preserved. He drew on Winnicottian concepts, and developed the idea that the framework could not be determined ahead of time by the therapist, but had to be constructed with the family. At the

limit, the very notion of therapy was eschewed (but not the goal of treatment).

The training of family therapists requires a personal psychoanalysis, but how necessary it is to have psychoanalytical experience with members of one’s own family is, as of 2005, still open to debate.

FRANÇOISE DIOT AND JOSEPH VILLIER

*See also:* Double bind; Group psychotherapies; Individual; Individuation (analytical psychology); Intergenerational; Secret.

### **Bibliography**

- Anzieu, Didier. (1971). L’illusion groupale. *Nouvelle Revue de Psychanalyse*, 4, 37–93.
- Berger, Maurice. (1986). *Entretiens familiaux et Champ transitionnel*. Paris: Presses Universitaires de France.
- . (1995). *Le travail thérapeutique avec les familles*. Paris: Dunod.
- Kaës, René. (1976). *L’Appareil psychique groupal: Constructions du groupe*. Paris: Dunod.
- Racamier, Paul-Claude. (1992). *Le génie des origines. Psychanalyse et psychoses*. Paris: Presses Universitaires de France.

### **Further Reading**

- Becker, Mitchel, and Shalgi, Boaz. (2002). A psychoanalytical approach to integrating family and individual therapy in the treatment of adolescents: A case study. *Psychoanalytic Study of the Child*, 57, 203–217.
- Sander, Fred. (1979). *Individual and family therapy: Toward an integration*. New York: Aronson.
- Stierlin, Helm. (1977). *Psychoanalysis and family therapy*. New York: Jason Aronson.

---

## **PSYCHOANALYTIC FILIATIONS**

In addition to intellectual, theoretical, and professional reasons, more personal ones usually play a part in the decision to take up an interest in psychoanalysis. Inextricably bound up with the former, but usually not as readily acknowledged or clearly understood as an influence on an individual’s choice of intellectual orientation, such psychoanalytic filiations run like a perpetual current through the life and work of the individual con-

cerned, for which reason questions about who analyzed him or her, when, how, why, and with what effect will continue to attract much attention both inside and outside the psychoanalytic community.

If collected and used properly, information about psychoanalytic filiations can help illustrate aspects of individual development, as may also be true when that individual does not subsequently engage with psychoanalysis professionally. However, where professional work follows, the psychoanalytic filiations between analyst and trainee acquire an additional significance, for in addition to involving conscious and unconscious processes at highly charged transference and counter-transference levels, they will themselves be an object of study during and after training, and their outcome, whether in the form of a resolution or not, will have an influence on the current and future work of both analyst and analysand.

Akin to and as powerful as—indeed repeating—characteristics of family life, such filiations have held the psychoanalytic community together as often as, when excessively active, they have threatened to tear it apart. Consequently, knowledge of the extent, nature and resolution of such psychoanalytic filiations is important for an understanding of individual psychoanalysts as well as of the movement as a whole.

Historically, psychoanalytic filiations preceded other forms of preparation for and involvement in psychoanalytic work (study of theory and work under supervision), and their explosive nature, particularly when not attended to psychoanalytically, showed in early dissensions and break-aways, as well as in expressions of excessive loyalty. But though seen by Freud and some early analysts as potentially too powerful, they did not lead to the adoption of a personal analysis as an obligatory part of training, but instead to the foundation in 1910 of international media (the International Psychoanalytical Association [IPA], the *Zeitschrift*, and congresses) to coordinate and assist local groups and coordinate the defense of psychoanalysis against outside critics. In fact, by the time the Secret Committee was formed (1912), only two of its members (Sandor Ferenczi and Ernest Jones) had had themselves been analyzed (and Ferenczi's plan that all should be analyzed by Freud was not realized). An analysis was not made an obligatory part of training until 1922. However, once accepted, it was clearly perceived both as a valuable support for trainees and as a potential threat to their independence, for which reason the

Berlin training model, which the IPA was then (Homburg Congress 1925) accepting as its benchmark, stressed “the same analyst should not conduct the instructional analysis of the candidate and later supervise him in the practical part of his training.”

As subsequent dissensions have shown, neither the Homburg nor any other principles have been able to prevent periodic recurrences of destruction or adulation within the psychoanalytic family. On the contrary, whether or not in the grip of unresolved problems, some training analysts have continued to create pro-selytes, and some trainees continue to use their psychoanalytic genealogy as legitimization of their own position and work, or as a weapon against others. On the other hand, since the institution of a personal analysis as an obligatory part of training, members of various groups have increasingly been able to explore disagreements, tolerate differences, and establish working alliances across divisions, both at local level, through the IPA, and by means such as exchange lectures, transfer of analysts, international conferences, and discussions at many levels about matters at times highly controversial.

However, openness at the level of psychoanalytic filiations remains a problem, not least because of a tendency in some analysts as well as some archivists, editors, and historians to withhold or misrepresent such highly personal information either in part or as a whole, typically with references to propriety or confidentiality. As a result, a crucial area of knowledge has not only been left open to speculation, but has been used by supporters and opponents of psychoanalysis alike to idealize or demonize institutions or individuals, to drive psychoanalytic thinking in the direction of dogma and petrification, and turn the writing of its history into an ideological act.

The problem of how, if at all, to use such information as can be obtained, remains. Clearly, simply refusing to consider it, either because it is incomplete or too difficult, is not an option for psychoanalysts who, by the same token, would indeed brand their profession as an impossible one. On the other hand, any decision on the part of psychoanalytic institutions to bring about change would be controversial, as it would involve the suspension of strict adherence to the principle of confidentiality where analysts and their trainees are concerned.

Obviously, disclosure of details about past and present psychoanalytic filiations, perhaps even by



putting the information into a database for psychoanalytic practitioners and historians to use, would greatly assist understanding and research, and it is encouraging that several present-day scholars seem interested in such a project. Naturally, only when—in each case—the effects of a person's psychoanalytic filiations have been validated, can they be truly useful to serious historians of psychoanalysis. The inevitable consequence—that there will also be richer pickings for the prurient—need deter no one, as experience shows that nothing inhibits speculation more than disclosure of facts, and that in cases where that does not work, nothing short of a thorough personal analysis will.

PAUL RIES

*See also:* History and psychoanalysis; Training of psychoanalysts; Transference.

### **Bibliography**

Falzeder, Ernst (1994). The threads of psycho-analytic filiations, or, psycho-analysis taking effect. In *100 years of psycho-analysis. Contributions to the history of psycho-analysis* (André Haynal and Ernst Falzeder, Eds.; pp. 169–194). Karnac: London.

Ferenczi, Sándor (1911). On the organisation of the psychoanalytic movement. In *Final contributions to the problems and methods of psycho-analysis* (Michael Balint, Ed.; pp. 299–307). New York: Brunner/Mazel.

Freud, Sigmund (1914d). On the history of the psychoanalytical movement. *SE*, 14: 7–66.

Granoff, Wladimir (1975). *Filiations. L'avenir du complexe d'Oedipe*. Paris: Les Éditions de Minuit.

Mijolla Alain de (1992). France 1893–1965. In *Psycho-analysis international. A guide to psycho-analysis throughout the world*. Volume 1: *Europe* (Peter Kutter, Ed.; pp. 66–113). Stuttgart: Frommann-Holzboog.

## **PSYCHOANALYTIC NOSOGRAPHY**

Is there a psychoanalytic nosography in the etymological sense of a rewriting and reorganization of psychopathology on the basis of psychoanalysis? And if so, is that nosography restricted, in its form and boundaries, to the sphere of psychoanalytic thinking and practice; that is, is there a psychoanalytical symptomatology for internal use only that does not coincide exactly with that of psychiatry? In answer to these questions, it is arguable that dynamic psy-

chology sought at first to dismantle several established clinical pictures and to erode the boundaries between the normal and the pathological, but that then, having exhausted the possibilities of this approach, it abandoned the efforts.

Alternatively, can psychoanalytic theory, or more precisely, metapsychology, perhaps be said in a more ambitious way to have revised the whole of psychopathology and placed it in a perspective where, reordered, it attained a new coherence? Indeed, psychoanalysis grew out of a questioning of psychiatry, and in particular, the neurological or mental nature of hysteria. Also, before writing *Studies on Hysteria* (1895d), Freud thoroughly scrutinized the normal clinical treatment of patients at that time.

Freud's study of dreams, his study of the development of sexuality, his model of the mental apparatus, and his positing of the unconscious all implied a broad transcendence of the clinical data from which he set out. Yet his quest for a new understanding of the neuroses nevertheless led him back to familiar categories: conversion, phobia, obsession, and anxiety. Freud found that, in the context of the interaction between affects and ideas, the mechanisms of defense could be most effectively differentiated on the level of symptoms, for this level yielded the greatest degree of explanation.

Yet even on this level, the level of Freud's first topography, the classical syndromes tended to reassume their old forms rather than to break down as their outlines came into clear view. A specific set of conflicts could be confidently aligned with parapraxes, with phobias, or with confused or delusional states. These diverse conditions were explicable by reference to a dynamic that the earlier categories of traumatic neurosis, transference neurosis, and actual neurosis had initially tended to define too narrowly—in terms that for this very reason have fallen out of use. All the same, Freud failed sufficiently to explore the vicissitudes of the interaction between primary and secondary processes (the affective and thought processes) in trying to better understand, on the basis of conflict, the various disturbances of consciousness that challenged the existence of the object. Accordingly, what Freud called “reality-testing” and described as an “institution of the ego” (1916–1917f [1915], p. 233) became an object of study alongside the still relevant material addressed in the clinical treatment of acute mental disorders.

Other questions had already arisen for Freud when he found it necessary to introduce narcissism into his theory (1914c). These questions obliged him to consider the withdrawal of libido from the object and redirection toward the ego, as well as its restitution. This consideration brought in, in different ways, the notions of depression, psychosis, and delusion. Clinical and therapeutic experience with such pathology demonstrated that its organization was too complicated to be adequately explained by its unconscious meanings alone. Here too the idea of narcissistic neurosis was not up to the task of circumscribing nuances and distinctions, and this remained true even after the category of narcissistic neurosis was subsequently limited to depression alone. At this point Freud focused on hypochondria as the main decompensatory tendency: “The relation of hypochondria to paraphrenia is similar to that of the other ‘actual’ neuroses to hysteria and obsessional neurosis” (p. 84).

To go more deeply into what, in 1895 in Draft G of the Fliess Papers (1950c), he had had to say about the essential nature of depression, Freud took classical melancholia as the basis for what he characterized as the withdrawal of the conflict into the ego (1916–1917g). Such narcissistic identification with the lost object already implied a second topography that would overturn earlier mental agencies and offer even the most “endogenous” psychiatry a vast range of possible dynamic explanations.

Furthermore, the heterogeneous borderline states, which have since achieved so much importance in clinical practice, can perhaps be unified only within the psychoanalytical perspective of seeing them as a narcissistic failure in dealing with conflict and avoiding depression by mobilizing a set of defenses against reality: negation, splitting, idealization, and so on.

As for psychosis, beginning with his discussion of the Schreber case (1911c [1910]), Freud suggested that it had roots deeper than merely the various projective modalities of the homosexual drive, deeper than merely the repression of reality (1924b, 1924e). Though loath to challenge the established German-language nosography of the day with regard to what he would have preferred to call “paraphrenia,” Freud felt that the subject’s the return to autoeroticism short of narcissism, the failure of thing presentations, and the opacity of the symbol in instances of “organ-speech” (1915e, p. 198) raised questions about what was at

stake in psychosis, namely the integrity of the ego and the objects that were incompatible with it.

Consideration of the psychic context of breakdowns of mental life, of Freud’s earliest questions concerning the actual neuroses, and of the development of psychosomatic medicine support the idea that, even though psychoanalysis has not invented a new nosography, it has nevertheless cast an incomparably clear light across the whole field of psychopathology and has provided a firm foothold to understand the field.

AUGUSTIN JEANNEAU

*See also:* Actual neurosis/defense neurosis; Alcoholism; Alienation; Character; Conflict; Narcissistic neurosis; “Psycho-Analytic Notes on an Autobiographical Account of a Case of Paranoia (Dementia Paranoides).”

### Bibliography

- Freud, Sigmund. (1911c [1910]). Psycho-analytic notes on an autobiographical account of a case of paranoia (*dementia paranoides*). *SE*, 12: 1–82.
- . (1914c). On narcissism: An introduction. *SE*, 14: 81–105.
- . (1915e). The unconscious. *SE*, 14: 159–204.
- . (1916–1917f [1915]). A metapsychological supplement to the theory of dreams. *SE*, 14: 237–258.
- . (1916–1917g [1915]). Mourning and melancholia. *SE*, 14: 237–258.
- . (1924b). Neurosis and psychosis. *SE*, 19: 147–153.
- . (1924e). The loss of reality in neurosis and psychosis. *SE*, 19: 180–187.
- . (1950c [1895]). Draft G. In his *The origins of psycho-analysis: Letters to Wilhelm Fliess, drafts, and notes, 1887–1902* (Eric Mosbacher and James Strachey, Trans.). London: Imago, 1954. (Revised translation in *SE*, 1: 200–206)
- Freud, Sigmund, and Breuer, Joseph. (1895d). *Studies on hysteria*. *SE*, 2: 48–106.

---

## “PSYCHO-ANALYTIC NOTES ON AN AUTOBIOGRAPHICAL ACCOUNT OF A CASE OF PARANOIA (DEMENTIA PARANOIDES)”

This paper is one of Freud’s great theoretical-clinical studies. It deals with the autobiography, published in

1903, of Daniel Paul Schreber, a mental patient whom Freud never met personally.

Schreber was the son of a physician who was a great believer in rigid educational methods. The young man studied and later practiced law. After a political setback, however, he fell victim to a depression accompanied by hypochondriacal ideas and spent six months (1884–1885) in a Leipzig psychiatric clinic run by Paul Emil Flechsig. In 1893 he was offered a significant promotion, but six months later he was admitted once again to Flechsig’s clinic, then transferred to an asylum, directed by Doctor Guido Weber, where he would remain for the next eight years after being diagnosed as suffering from “paranoid dementia.”

During this eight-year period, he first went through a phase of intense hallucinatory delusion characterized by an extremely disorganizing anxiety; he then organized his delusions somewhat, eventually achieving a degree of stability that allowed him (at his own request) to argue for his freedom (with great legal talent) and to regain it by a judgment of the Royal Appeal Court of Dresden dated July 14, 1902.

Over the years Schreber had taken occasional notes, and toward the end of his internment he made these the basis of a book, which he succeeded in having published in 1903 under the title *Denkwürdigkeiten eines Nervenkranken* (Memoirs of a neuropath). Many passages were excised at the behest of the publisher—and, one may suspect, at the behest of Schreber’s family to conceal the family’s great sexual crudity. It is essential to read Schreber’s book, translated as *Memoirs of My Nervous Illness* (1955), in order fully to appreciate the commentary Freud offered on it a few years later. It provides a very eloquent description of the sensory hallucinations to which Schreber fell prey, along with his own explanation of them. According to this explanation, these sensations were imposed on him by God, by means of “divine rays” connected directly to his body, and specifically to his nerves. Schreber strove mightily to satisfy God by procuring the “voluptuous sensations” that God demanded, yet at the same time he waged a ferocious, superhuman struggle to free himself from the rays.

Schreber’s God was a strange, capable of this terrifying kind of possession, yet at the same time pitiful, inasmuch as God understood nothing about humans and ardently sought to become acquainted with their sensations. In Schreber, God found a unique being

who gave God an ardently wished-for connection. This God, who had a dual nature (Schreber evoked the dualism of Ahriman and Ormuzd found in Zoroastrianism), had created a replica of himself in Flechsig (who was also divided into two, but who was liable to shatter into many pieces at certain moments), and Flechsig had been God’s agent with regard to Schreber. The incoherence of this account is immediately apparent, yet it is a poignant testimony to a sick man’s desperate struggle to establish a level of meaning that he could accept and that would free him from his incoherent anxiety about disintegration.

Little by little, Schreber’s explanation organized itself into a vast theological cosmogony: The world was coming to an end, and for a whole stretch of time Schreber was the sole survivor, surrounded by shadows, semblances of men, mere apparitions. A new humanity would supposedly be born from Schreber himself, provided that he is transformed into a woman and offered God the voluptuous feelings of women’s pleasures.

Schreber published his book to enlighten psychiatrists. Granted, he was mentally ill (as indicated in the title of his autobiography), but the causes of his illness were quite different from what the psychiatrists attributed it to. Schreber, above all, wanted to convey his message to people at large in order to enlighten humanity about essential truths.

It is instructive to read the clinical reports of Dr. Weber appended to Schreber’s narrative (1955, pp. 267ff.), for they offer a remarkable description of how a calming delusional system can cure anxiety. Also of great interest is the wise judgment passed by the appeals court in Dresden (Schreber, 1955, pp. 329–356), which discharged Schreber in 1902. The court forcefully declared, in effect, that Dr. Schreber was completely mad, but that his worldview was interesting, and that he no longer represented any danger to himself or others. Indeed, after his release Schreber passed several uneventful years before being recommitted and dying in an asylum in 1911, the very year in which Freud published his study of the case.

When he worked on this text, Freud had been engaged for two or three years in a sustained discussion of the psychoses with Carl Jung. From these discussions Freud he expected much of value to emerge, though the first signs of Jung’s coming break with Freud were already beginning to appear. Freud made no attempt here to account for all the psychopatholo-

gical phenomena and processes characterizing Schreber's illness. Rather, as in all of Freud's great clinical writings, his purpose was to prove something. In this case he set out to demonstrate that the motor of the paranoiac's persecution anxiety and delusional worldview is related to issues attending homosexuality, as was strikingly revealed by Schreber's delusions.

The first part of Freud's discussion, "Case History," though it hews close to Schreber's *Memoirs*, nevertheless presents the material that will serve to illustrate the thesis set out in the second part, "Attempts at Interpretation." In Freud's view, Flechsig, as a doctor admired by Schreber, is the privileged object of Schreber's homosexual desire, a desire justified and indeed sanctified by his delusional system. Yet the roots of Schreber's homosexual desire must be sought in his relationship with his father, Daniel Gottlieb ("God's love") Moritz Schreber, a relentless educator who promoted absolute submission to God's will. In this case the father, it would seem, was the bane of his children's lives (an elder brother of Daniel Paul killed himself, while a younger sister was a confirmed mental patient).

In the third and last section of his study, "The Mechanism of Paranoia," Freud analyses the process of projection that constitutes the paranoiac's chief defense and organizes the paranoiac's delusions of persecution: the basic homosexual desire, "I (a man) love him (a man)," is negated into "I do not love him—I hate him," which then, as a result of projection, becomes "He hates (persecutes) me," and from this the paranoiac derives the justification "I do not love him—I hate him—because he persecutes me" (1911c [1910], p. 63). What we have is a system of transformations to defend against homosexuality. Freud presents two more variants of such systems, one being the mechanism at work in erotomania and the other the mechanism mobilized in delusions of jealousy. (A fourth possible mode of defense against homosexual desires embraces the formula "I do not love at all—I do not love anyone.")

This work of Freud's spawned a large number of discussions and commentaries, the most notable of which are cited in the bibliography below.

ROGER PERRON

*See also:* Castration complex; Delusion; Dementia; Ego instincts/ego drive; Fixation; Friendship; Hypochondria; Megalomania; Narcissism; Paranoia; Paraphrenia; Persecution; Projection; Rationalization; Schizophrenia; Schreber, Daniel Paul; Sublimation.

### Source Citation

Freud, Sigmund. (1911c [1910]). Psychoanalytische Bemerkungen über einen autobiographisch beschriebenen Fall von Paranoia (Dementia paranoides) [Schreber]. *Jb. psychoanal. psychopathol. Forsch.*, III, p. 9–69; *GW*, Vol. 8, p. 239–316; Psycho-analytic notes on an autobiographical account of a case of paranoia (*dementia paranoides*). *SE*, 12: 1–82.

### Bibliography

- Israëls, Han. (1989). *Schreber: father and son*. Madison, CT: International Universities Press. (Original work published 1981)
- Kanzer, Mark, and Glenn, Jules (Eds.). (1980). *Freud and his patients*. New York: Jason Aronson.
- Lothane, Zvi. (1992). *In defense of Schreber: Soul murder and psychiatry*. Hillsdale, NJ: Analytic Press.
- Prado de Oliveira, and Luis Eduardo (Ed.). (1979). *Le cas Schreber: Contributions psychanalytiques de langue anglaise*. Paris: Presses Universitaires de France.
- . (1997). *Freud et Schreber: Les sources écrites du délire, entre psychose et culture*. Paris: Érès.
- Schreber, Daniel Paul. (1955). *Memoirs of my nervous illness* (Ida Macalpine and Richard A. Hunter, Trans.). London: Dawson. (Original work published 1903)

---

## PSYCHOANALYTIC QUARTERLY, THE

*The Psychoanalytic Quarterly* was founded in 1934 by four analysts: Bertram Lewin, Gregory Zilboorg, Dorian Feigenbaum, and Frankwood Williams. Their editorial policy, enunciated explicitly in the first issue, was directed at a specific task. Psychoanalysis was becoming quite popular in North America, and while the enthusiasm was welcome, it also gave rise to a certain amount of confusion. The founders of *The Psychoanalytic Quarterly* wanted to establish a forum for the discussion of psychoanalytic ideas that have *clinical* relevance.

*The Psychoanalytic Quarterly* has always addressed the interests and concerns of the analytic practitioner. Theoretical and applied analytic studies are welcome, but only if they generate hypotheses a clinical analyst can bring back to the treatment situation and test against observations made there. An empirical, pragmatic orientation informs the journal's editorial policy.

*The Psychoanalytic Quarterly* also directs itself against the inevitable parochialism of local analytic subcultures by exposing its readers to work done from an array of theoretical perspectives. For example, *The Psychoanalytic Quarterly* was the first journal in the United States to publish an article by Jacques Lacan. Special issues have taken up such topics as “Knowledge and Authority in the Psychoanalytic Relationship” and “The Psychoanalytic Process,” featuring papers by a variety of analysts from widely differing schools of thought.

In addition to original scientific contributions, *The Psychoanalytic Quarterly* includes a comprehensive Book Review Section. It also has an Abstracts Section, in which summaries of selected articles from other journals—virtually the entire non-English language psychoanalytic literature, as well as the neural sciences, philosophy, sociology, infant observation, political science, and so on,—are presented.

*The Psychoanalytic Quarterly* is a free-standing, self-published journal. It contains no advertising, and is supported by subscription fees. It is not accountable to any psychoanalytic organization. Therefore, *The Psychoanalytic Quarterly* has been able to maintain a tradition of complete editorial independence alongside intellectual rigor and fine scholarship.

OWEN RENIK

See also: Fenichel, Otto; *Revue française de psychanalyse*; United States.

---

## PSYCHOANALYTIC RESEARCH

Research, whether to create scientific advances or investigate historical and epistemological issues, is generally supported by the state and is often carried out by specialized institutions or in laboratories. In psychoanalysis, research with a view to theoretical and clinical advances has sometimes been conducted in such settings, but it has also been conducted by individuals and psychoanalytic associations. Freud’s hope, that analysis would find a place in the university in ways that would ensure its status as a separate discipline, has been partially fulfilled: from the 1960s, dissertations in the field of psychoanalysis

have begun to appear in countries around the world.

Psychoanalytic research implies scientific standing, and a persistent issue has been whether analysis is a science. If science is limited to experiment and the use of mathematical tools, the answer is no. This has been the view of such prominent philosophers as Karl Popper and Alfred Grünbaum, for whom psychoanalysis presents a body of claims that cannot be falsified or refuted. But the scientific nature of psychoanalysis has also been questioned by those who prefer to see it as an art, not so much to be taught as transmitted. It thus escapes the objective criteria on which the sciences, whether physical or social, are based.

For Freud, psychoanalysis has a place among the sciences and shares its worldview: it is above all a method of investigating unconscious processes and could be adapted for use in fields unrelated to therapy. In this sense, psychoanalytic theory comprises a set of hypotheses and concepts subject to constant revision. Therapy is one possible application of psychoanalytic method and is also to a great extent its source, because therapy provides the link between theory and clinical practice, the space in which the principal hypotheses are developed and tested.

Freud distanced psychoanalysis from religion and philosophy, from unverifiable constructions in general, and from medical pragmatism. In 1911 he signed a manifesto, together with Albert Einstein, David Hilbert, Ernst Mach, and about thirty others, that appealed for the creation of a society to disseminate positivist philosophy in order “to outline a vast vision of the world on the basis of positive facts that each science has accumulated” (quoted in Hoffmann, 1995).

Psychoanalysts have developed a relatively independent network by which they exchange ideas and information at professional seminars and colloquia. While university research provides new and original perspectives and is designed to address questions by reexamining them within the context of history and the critical perspective of previously published work, independent researchers often come up with their own clinical findings of the type they believe the clinical setting can provide. Some of these researchers may formulate more general hypotheses, which they then test in various clinical situations.

The actual content of psychoanalysis also affects how research is conducted. In terms of theory, psycho-

analysts have produced a body of notions and concepts—two terms that should not be confused. In psychoanalysis, fundamental concepts (*Grundbegriffe*), or even keystones (*Grundpfeiler*), are not a priori categories but result from investigations into mental processes. These create the scaffolding that Freud called “metapsychology,” the theoretical superstructure that includes such useful fictions as the psychical apparatus. For Freud, metapsychology was necessary for advancing new ideas but could always be modified or revised.

The “fiction” of a “psychic apparatus,” noted in *The Interpretation of Dreams* (1900a), was followed by the first theory of the instincts with its dualities of the self-preservation and sexual instincts and of the pleasure/unpleasure principle. Freud introduced narcissism in 1914, which led to a revision of the theory of the ego and ego ideal, and in 1920, in *Beyond the Pleasure Principle*, he introduced the dualism of the life and death instincts. Although these theoretical developments, advanced through clinical practice, did not require a reconstruction of the metapsychology, revision did arise from certain particularly innovative notions in psychopathology.

Ongoing clinical work, with its infinite diversity of patients and variety of psychological facts, vastly added to the number of notions in psychoanalytic theory. Not all notions fared equally well. Some met a clinical need, while others fell into such disuse as to interest only historians of psychoanalysis, who sometimes resuscitate lost notions or bring forth new ones that originated in forgotten antecedents.

Psychoanalytic theory and investigation have produced an abundant literature, often a surfeit that makes it impossible to read everything written in any particular area. For this reason, the division of research between academicians and individual practitioners would appear to be complementary and desirable.

SOPHIE DE MIJOLLA-MELLOR

*See also:* Applied psychoanalysis and the interaction of psychoanalysis; Hard science and psychoanalysis; Knowledge or research, instinct for; Truth.

### **Bibliography**

Freud, Sigmund. (1900a). The interpretation of dreams. *SE*, 4: 1–338; 5: 339–625.

———. (1920g). Beyond the pleasure principle. *SE*, 18: 1–64.

Gori, Roland. (1996). *La preuve par la parole: Sur la causalité en psychanalyse*. Paris: Presses Universitaires de France.

Hoffmann, Christian. (1995). Le manifeste positiviste signé par S. Freud en 1911. *Cliniques Méditerranéennes*, 45–46, 7–11.

Laplanche, Jean. (1995). La psychanalyse dans la communauté scientifique. *Cliniques Méditerranéennes*, 45–46, 33–42.

Mijolla-Mellor, Sophie de. (1995). Potentialité des scissions dans la théorie psychanalytique elle-même. *Topique*, 57, 291–306.

### **Further Reading**

Schachter, Judith, and Luborsky, Lester. (1998). Who's afraid of psychoanalytic research? *International Journal of Psychoanalysis*, 79, 965–970.

Shapiro, Theodore, and Emde, Robert N. Ed (1995). *Research in psychoanalysis: Process, development, outcome*. Madison, CT: International University Press.

Vaughan, Sarah, et al. (2000). Can we do psychoanalytic outcome research? A feasibility study. *International Journal of Psychoanalysis*, 81, 513–528.

Wallerstein, Robert. (2001). The generations of psychotherapy research: An overview. *Psychoanalytic Psychology*, 18, 243–267.

---

## **PSYCHOANALYTIC REVIEW, THE**

The contemporary *Psychoanalytic Review* can trace its lineage to two disparate yet converging journals in the history of American psychoanalysis.

The original *Psychoanalytic Review* was founded in 1913, making it the first English-language journal dedicated to psychoanalysis, and as the oldest continuously published psychoanalytic journal in the world. Smith Ely Jelliffe (1866–1945), one of the journal's founders, was a neurologist who became interested in psychoanalysis through the influence of Abraham Arden Brill. He was also influenced by the writings of Adler and Jung, and advocated for the journal a general psychodynamic perspective on behavior, free of sectarian bias. The other founder, William Alanson White (1870–1937) was superintendent of the Government Hospital for the Insane in Washington, D.C., and one of the pioneers in psychoanalytic psychiatry.

*Psychoanalysis*, the other parent of the present journal, was founded in 1952 by the National Psychological Association for Psychoanalysis (NPAP), the first publication of its time situated and representing a non-medical training institute. Theodor Reik was Editor-in-Chief, and the editors were John Gustin and, later, Clement Staff. In 1958, *Psychoanalysis* absorbed *The Psychoanalytic Review* and for the next five years appeared as *Psychoanalysis and The Psychoanalytic Review*, under the direction of Marie Coleman Nelson as managing editor and Murray Sherman as assistant editor and later as co-editor and editor.

The name *Psychoanalysis* was dropped for the first issue of 1963 and henceforth the journal has been known as *The Psychoanalytic Review*, having been edited by Marie Nelson, Murray Sherman, Leila Lerner, and Martin Schulman.

*The Review* has occupied a unique niche in the history of the psychoanalytic movement, both in the United States and in the international arena. It has always represented a non-sectarian, open venue for all psychoanalytic perspectives. This openness, and refusal to see psychoanalysis as a finite body of truism analogous to a religion led Ernest Jones, in 1924, to call it a "refuge of all malcontents." Schulman sees it, rather, as a forum for those, not malcontent, but discontent with orthodoxy, sectarianism, dogma, and exclusionism. While scholarship and literary style are the prerequisites for the acceptance of articles, the journal is a setting for all legitimate perspectives within the psychoanalytic movement.

It has published representational articles by classical Freudians, Ego psychologists, object-relations theorists, Kleinians, self-psychologists, Lacanians, and even contemporary Jungian theorists.

It has continued to be committed not only to clinical psychoanalysis, but to a psychoanalytic exploration of general culture, seeing psychoanalysis as informed by other disciplines, rather than reducing all discourses to a superordinate psychoanalytic frame. It is representative of the general philosophy of critical inquiry, and psychoanalytic scientific humanism, the historical foundational core of psychoanalysis.

MARTIN A. SCHULMAN

See also: National Psychological Association for Psychoanalysis.

## PSYCHOANALYTIC SEMIOLOGY

Semiology, the science of signs, gains its meaning from being communicable within a given field of science. The same holds true for somatic medicine, following what Michel Foucault described in 1963 as the "fundamental isomorphism of the structure of disease and the verbal form that describes it." The sign indicates the symptom, just as a wheeze indicates pneumonia. Woven into the mesh of concrete banality and everyday life, psychiatric symptomology lends itself less easily to a system of directly meaningful and unchanging references. From this viewpoint psychoanalysis appears to escape any form of semiology that might be useful in treatment. But metapsychology, which theorizes experience and justifies procedure, does supply a form of semiology that is both specific to it and appropriate in certain situations.

The only semiology useful to the clinical situation is specifically context dependent, belonging solely to a particular analyst/analysand relation. The observer, the analyst, is involved in a unique relation involving the dynamic of transference and counter-transference. Therefore the reality involved in analysis, even when it concerns external facts, can only serve as a reference frame for a fantasy that supports the narrative at a particular moment, for reasons that are specific to it alone. At most the reality of analysis, its framework and the patient's attitude can, from one case to another, present some invariant elements. At all other times the sign will depend only on the context; to this extent, the symbol can express the contrary to what it might indicate elsewhere. We know that defenses can take the form of a movement of the drive and that interpretation provides no truth, but reveals a pathway of associations and reroutes energy between two signposts without any absolute value. And finally, nothing can at the same time be experienced and understood other than in small doses (Strachey, 1934).

Nonetheless, metapsychology can shape a semiology that can be applied in three areas. During the evaluation, it can help to understand psychic structure and function, and thus indicate modes of therapy. The ability to associate, observed during the interview, or their various avatars, the defensive methods of repression, denial, projection, and so on, the expression of affects, and regressive forms, are all elements that can constitute a system of signs for evaluating the manifestations of the unconscious and their dynamic in the organization and operation of psychic agencies. Similarly, one

can read the inconsistencies and weak points in a conflict, where the risks of depressive or delusional decompensation are present. A semiotic method is perhaps even more useful in cases where a breakdown is manifested through psychosomatic symptoms. These same semiological data could be used by psychotherapy, in which the patient apprehends external reality. Such data can clarify fears of the phobic patient with regard to oedipal positions. The splittings and idealizations of the borderline patient can split, or idealize, for reasons of archaic violence and narcissistic fragility.

Finally, psychiatry as a whole can be entirely revised in light of psychoanalytic semiology, which intersects psychiatric semiology, introducing the dynamic of metapsychology into clinical situations, where the unconscious reveals its presence in the most biological manifestations and the most external events.

AUGUSTIN JEANNEAU

*See also:* Neurasthenia; Psychoanalytic nosography; Psychotic/neurotic; Symptom-formation.

### **Bibliography**

Foucault, Michel. (1994). *The birth of the clinic: An archaeology of medical perception* (A. M. Sheridan Smith, Trans.). New York: Vintage. (Original work published 1963)

Strachey, James. (1934). The nature of the therapeutic action of psycho-analysis. *International Journal of Psycho-Analysis*, 15, 127–159. Reprinted 1969, *International Journal of Psycho-Analysis*, 50, 275–291.

### **Further Reading**

Gay, Volney P. (1982). Semiotics as metapsychology: The status of repression. *Bulletin of the Menninger Clinic*, 46, 489–506.

Harris, Adrienne, and Aron, Lewis. (1997). Ferenczi's semiotic theory: Previews of postmodernism. *Psychoanalytic Inquiry*, 17, 522–534.

Olds, David. (2000). A semiotic model of mind. *Journal of the American Psychoanalytic Association*, 48, 497–530.

---

## **PSYCHOANALYTIC STUDY OF THE CHILD, THE**

In 1945 there appeared a new journal, four hundred pages long, titled *The Psychoanalytic Study of the Child*. Due to its editors (Anna Freud, Heinz Hartmann,

Ernst Kris) and its contributors (such as Edward Glover, Ernst Kris, René Spitz, Phyllis Greenacre, and Rudolph Loewenstein), the journal immediately enjoyed huge success and prestige. Ever since, the journal has appeared regularly every year, always in the same format and always just as thick. More than fifty volumes stretch along the bookshelves of psychoanalytic institutions throughout the world.

Right from the start, its intellectual and political mission was clear. Heinz Hartmann had just immigrated to New York. In London, the disciples of Anna Freud and Melanie Klein were emerging from several years of intense and sometimes violent quarrels. While one could hardly say that Anna Freud's star was fading, that of Melanie Klein was shining ever brighter. But this was in Britain. On the other side of the Atlantic, the situation was different. The United States still appeared as a vast and as yet wide-open field, professionally shapeless and ill-defined. In particular, it still needed an infusion of Klein's new teaching. Hence the value not just of creating an English-language journal, but also of publishing it in New York.

The 1945 volume contained declarations on the part of Hartmann, Anna Freud, and Edward Glover, among others. They stated their thinking in the most trenchant terms: the psychoanalysis of children was a success, and its principles should be based on the later metapsychology of Sigmund Freud or, more precisely, on Freudian metapsychology as interpreted by Hartmann and Anna Freud.

The threat from Klein was staved off by a cunning ploy. In volume 1, Klein was the subject of detailed discussion, and her "deviations" were denounced. After this discussion, there was near silence. In the following years, her name was rarely mentioned. Even in 1952, when she made a brief reappearance in the journal, it was as the author of a mere three-page heavily criticized commentary (7, pp. 51–53) of a paper given by Hartmann at the 1951 congress of the International Psychoanalytical Association. As for Jacques Lacan, his existence was never even recognized during his lifetime (the first article on Lacan, critical but nonetheless well intentioned, appeared in 1993 [48, pp. 115–142]). Despite the international tone of the first volume (which included articles by Marie Bonaparte and Raymond de Saussure), during the following years *The Psychoanalytic Study of the Child* militantly limited its horizons to the Anglo-Saxon world.



Such doctrinal parameters might have paralyzed original thought, but this was far from the case. On the contrary, the 1950s saw an upsurge of creativity. Anna Freud and Hartmann, in articles exceptional in their quality, consolidated and refined their shared perspective. During the same period, a new line of thinking started to emerge. In 1952 Margaret Mahler published “On Child Psychosis and Schizophrenia: Autistic and Symbiotic Infantile Psychoses” (7, pp. 286–305), which drew a huge response. Then in 1954 came Edith Jacobson’s “The Self and the Object World” (9, pp. 75–127). Structural psychology, as the theoretical framework of Anna Freud and Hartmann came to be known, then had to reach a compromise with the new object-relations theory. Ironically, one of the strengths of object-relations theory lay in the sophisticated way in which Klein’s key concepts had been reworked—for instance, the role of so-called primitive defenses during the pre-oedipal period.

At the end of the 1960s and during the 1970s, the wave of object-relations theory continued to develop: case studies were more and more frequently labeled “separation-individuation,” “fusion anxiety,” “object permanence,” and the like. During the 1980s, object-relations theory became more important than structural psychology. Nonetheless, both viewpoints managed to coexist in the review and have continued to do so. Even after her death in 1984, Anna Freud remained a powerful presence. A good example of her unflinching authority is an excellent article by Clifford Yorke, “Anna Freud’s Contributions to Knowledge of Child Development,” published in 1996 (51, pp. 7–24). In this paper Yorke endeavored to produce the most detailed investigation of all the journal articles written from the perspective of Anna Freud.

One significant result of the increasing space given to “representations of the self and the object” was the rise in importance of the Anglo-Saxon version of parent-infant psychotherapy. Selma Freiberg was the main innovator here, and the journal has continued to support this current (Liebermann and Pawl, 39, pp. 527–548; Seligman, 49, pp. 481–500).

Another subsidiary development emerged with the publication, in 1978, of “Trauma and Affects,” by Henry Krystal (33, pp. 81–116). Krystal argued for a more rigorous definition of the concept of trauma and recommended that greater attention be paid to the consequences of this notion for the psychoanalysis of

the child. In 1979 and 1984 there appeared two widely-read articles by Lenore Terr: “Children of Chowchilla: A Study of Psychic Trauma” (34, pp. 547–623) and “Time and Trauma” (39, pp. 633–665). *The Psychoanalytic Study of the Child* was one of the main journals to grant an important place to the subject of trauma, which later became a major focus of interest in the world of child therapy.

As might have been expected, what remained problematic for the journal was its relation to research on child development. In the first years, a simple solution seemed to suffice. In the first volume (1945), the hope was forcefully expressed that research might become more central. In practice, this intention amounted to almost nothing. For a long while, the sole empirical studies recognized by the journal were those practiced by its own editors and a few key contributors: Anna Freud’s diagnostic observations at the Hampstead Clinic, Margaret Mahler’s investigations on day nurseries, René Spitz’s studies on hospitalization, Ernst Kris’s observations at Yale University. In 1959, John Bowlby read a paper before a large audience during a meeting of psychoanalysts in New York. His presentation, “Grief and Mourning in Infancy and Early Childhood,” published in the 1960 volume (15, pp. 9–52) was vehemently attacked by Anna Freud (15, pp. 54–61).

At the end of the 1970s, this state of affairs changed radically. “Outstanding Developmental Progress,” a longitudinal study by Bertrand Cramer (who was working in New York at the time) appeared in 1975 (30, pp. 15–48). “Four Early Stages in Development of Mother-Infant Interaction,” an important article by T. Berry Brazelton and Heidelise Als on video studies of mothers and infants, was published in 1979 (34, pp. 349–369). Even more revealing, the main specialists in early infancy in the 1990s, such as T. Berry Brazelton, Daniel Stern, and Edward Tronick, began to be cited frequently by various authors in the journal in the 1970s. This tendency, which continued during the 1980s and 1990s, represents a praiseworthy movement toward more openness. Yet the most surprising thing is that investigators seemed to imagine they could assimilate the new discoveries to the existing metapsychology without raising some rather complex questions. One would expect more objections, such as those of Fred Pine, who, in a fine 1992 article, “The Separation-Individuation Concept in Light of Infant Research” (47, pp. 103–116), brought out the existing disagreements between Mahler and Stern.

Despite the reservations one may have on its omissions, *The Psychoanalytic Study of the Child* has maintained a high level of professionalism. Few journals in the history of psychotherapy have managed as well as this one to retain their influence while remaining lively, dynamic, and provocative in theoretical matters.

GEORGE DOWNING

See also: Eissler-Selke, Ruth; Freud, Anna; Hartmann, Heinz; Kris, Ernst; Kris-Rie, Marianne.

---

## **PSYCHOANALYTIC THEORY OF NEUROSIS, THE**

Otto Fenichel's *The Psychoanalytic Theory of Neurosis* is widely considered the standard reference work on this subject. It also offers a systematic summary of the literature of psychoanalysis up to the Second World War. With its seven hundred pages and its 1,600-entry bibliography, the work has contributed significantly to its author's reputation as a first-rank theorist and "encyclopedist" of psychoanalysis.

In a brief Preface, Fenichel describes how the book was conceived. After many years of activity in a training capacity and as a lecturer in various psychoanalytical institutes in Europe and America, and of vigorous participation in internal debates on theoretical deviations and on the internal practices of psychoanalysis, he had decided not to work on a second edition of his earlier *Outline of Clinical Psychoanalysis*, first published in two volumes by the Internationaler Psychoanalytischer Verlag in Vienna in 1931, and in English translation in 1934, but rather to produce a completely new work.

Fenichel began writing *The Psychoanalytic Theory of Neurosis* in Prague, and Freud proposed the work to the Verlag. In May 1943, the author made a formal statement about his project at the Meeting of the American Psychoanalytic Association in Detroit. In view of all the misunderstandings, obscurities, and deviations then besetting psychoanalysis, and in view of the continual temptation to revive resistances within the movement, it was much to be desired, he felt, that the essential part of Freud's dynamic psychology be set forth in the clearest way. He hoped to

contribute to this task by writing a "Psychoanalytic Theory of the Neuroses."

In his introductory chapters, Fenichel sets forth his scientific position, stresses his views on changes noted in psychoanalytical theory, and defines his goal, namely to understand and institute Freudian psychoanalysis as a psychology, as a natural science. In this way he hoped to keep at arm's length psychoanalysts who confined themselves to a partial view of psychoanalytic theory, reducing it in a psychologizing or biologizing way, and hence overvaluing or neglecting one or another of its aspects. Part One of Fenichel's book is devoted to an account of general mental development from the psychoanalytical point of view; Part Two describes the various defining characteristics and forms of the neuroses.

Fenichel was very conscious of the cultural import of psychoanalysis, and conceived it as his "vital duty" to work for "the conservation, extension, and correct application" of Freud's discoveries. Against this background, Fenichel's book was designed to preserve the clinical basis of psychoanalysis, its libido theory, the foundations of its theory of the instincts, and its account of the perpetual conflict and interaction between the frustrations of the outside world and the demands of the instincts.

ELKE MÜHLEITNER

See also: Addiction; Bulimia; Dependence; Dipsomania; Fenichel, Otto; Indications and contraindications for psychoanalysis for an adult.

### **Source Citation**

Fenichel, Otto. (1945). *The psychoanalytic theory of neurosis*. New York: Norton.

### **Bibliography**

Fenichel, Otto. (1934 [1931]). *Outline of clinical psychoanalysis*. New York: Norton.

---

## **PSYCHOANALYTIC TREATMENT**

The psychoanalytic treatment is a method for treating psychic suffering that advances self-knowledge. It is characterized by the interpretation of the free associa-

tions of a patient, who in becoming aware of feelings and forgotten memories, can thus resolve or express differently the unconscious conflicts behind his/her neurotic symptoms. The way sessions are structured—couch and armchair—and their frequency and regularity facilitate this process through the transference onto the psychoanalyst of affects and childhood fantasies.

From 1886, when he set himself up in private practice to 1909, the year of the “Rat Man” analysis, Freud gradually developed the system of psychoanalytic treatment. In fact the method emerged from the hypnotic treatments that he used after his recognition of the failure of medicinal and physical therapies in vogue at the time. Sessions in which the patient relaxed on a couch in an atmosphere of calm and comparative sensory deprivation resulted from the conditions imposed by somnolent suggestion and later by the “cathartic method” developed by Joseph Breuer to treat his patient, Anna O. Patients themselves contributed towards the maturation of the structure of the treatment, beginning with Emmy von N’s command at their first encounter on May 1, 1889, to “Keep still! Don’t say anything! Don’t touch me!” and her angry demand that he stop interrupting and let her speak freely.

The abandonment of hypnosis in favor of an interrogatory technique, and the application of pressure to the forehead to release ideas, repressed through resistance, introduced a decisive turn in method, even though Freud appears to have taken a particularly active role, insisting patients surrender the pathogenic secrets buried in their unconscious, as the chapter entitled “The Psychotherapy of Hysteria” in *Studies on Hysteria* demonstrates (1895d).

*The Interpretation of Dreams* (1900a) introduced the innovation “free association,” which would become the “fundamental rule” of all psychoanalytic treatment. At the same time the therapist was required submit to the principle of “evenly suspended attention” which entails the scrutiny of even the most apparently insignificant detail (Freud, 1904a).

Freud could thus describe his “psychotherapeutic method” in 1904 as follows: “Without exerting any other kind of influence, he invites them to lie down in a comfortable attitude on a sofa, while he himself sits on a chair behind them outside their field of vision. He does not even ask them to close their eyes, and

avoids touching them in any way, as well as any other procedure which might be reminiscent of hypnosis. The session thus proceeds like a conversation between two people equally awake, but one of whom is spared every muscular exertion and every distracting sensory impression which might divert his attention from his own mental activity” (1904a, p. 250). Through the transference, whose importance Freud had discovered with his patient Dora, resistance became common, both as an obstacle to treatment and as its major driving force.

There remained one last significant innovation in technique, which Freud reported to his disciples at a meeting of the Vienna Society on November 6, 1907, via an account of the early stages of his treatment of the “Rat Man.” Otto Rank noted in *The Minutes of the Vienna Psychoanalytic Society* that “analytic technique has been modified to the extent that the psychoanalyst no longer actively seeks to obtain material that interests him, but rather allows the patient to follow the unprompted and natural course of their thoughts.”

Hereafter the framework was determined and has remained to the present day. The features that Freud was to recall in “On Beginning the Treatment” (1913c) include the analyst’s position outside the reclining patient’s line of vision, regular sessions of a prescribed duration, and terms for the payment of fees. These conditions create the setting for a “psychoanalytic situation” in which, for Jacques Lacan (1953) and his followers, the principal, indeed the exclusive role, would be one given to speech; but a speech and an aural attention going beyond words to include silences, expressions of affect, and even minuscule movements. Freud had observed this when treating Dora: “If his lips are silent, he chatters with his fingertips; betrayal oozes out of him at every pore. And thus the task of making conscious the most hidden recesses of the mind is one which it is quite possible to accomplish” (1905e, p. 78).

Even when supplemented by professional motives (as in training analysis), it is psychical suffering that compels individuals to consult a psychoanalyst. After one or more preliminary interviews, which Freud advised should not be repeated and in relation to which he preferred “a trial treatment of one to two weeks” (1913c), the direction of the treatment is set out; the two protagonists then decide whether to embark on this venture whose initial temporal duration is indeterminate but whose eventual length is

assured. “To speak more plainly,” added Freud, “a psycho-analysis is always a matter of long periods of time [...] of longer periods than the patient expects. It is therefore our duty to tell the patient this before he finally decides upon the treatment” (p. 129).

Since Freud some features of this initial framework have changed; thus the six hour-long sessions per week were reduced to five, then to four, and eventually to three and the length of sessions has been cut from one hour to forty-five minutes. Following his lead, disciples of Lacan have instituted short sessions, and even sessions whose variable length is based on the analyst’s attention to the scansion effect in his patient’s discourse, a practice that has been keenly disputed. Some analysts believe that two sessions per week is possible, others, that the couch advocated by Freud is in no way an absolute requirement.

The notion of a “standard treatment” (Bouvet, 1954), which was similar to descriptions of the medical standard that characterized the manuals of the 1950s, was counterbalanced by what were described as its “variants” (Lacan, 1955); it has now been replaced by the “classic” or indeed the “orthodox” treatment for those who see themselves as liberated from its formal constraints.

It is essential that a “psychoanalytic process” be established and that it is encouraged to advance through the development of the transference neurosis, whose infantile origins are revealed in analysis, but that it is also always jeopardized by the initiation of a “negative therapeutic reaction” which would counter the original love-based “therapeutic alliance.” The analyst’s “abstinence” in the face of the patient’s demands for affective gratification is a requirement for this development, as is his capacity to manage conflicts that may engender “secondary gains” from the illness and, once the initial honeymoon period is over, a transference and countertransference relationship that is as intense as it is unusual. According to Freud: “the therapeutic effect depends on making conscious what is repressed, in the widest sense of the word, in the id” (1937c). Analytic interventions address this aim, but more importantly so too do interpretation, construction, and reconstruction (1937d) as well as the analysis of resistances and the dispelling of amnesia that masks infantile sexuality. Active periods alternating with inactive phases, which for Freud were occasionally indicative of a patient’s “working through” (*Durcharbeitung*) of the material analyzed, mark the stages of what has been

described as “autohistorization” (P. Aulagnier) and highlights the journey towards autonomy which will determine the treatment’s cessation.

The termination of analysis has occasioned a number of studies since Freud’s own (1937c) and is dependent on the aims that the psychoanalyst and the analysand have given themselves. Curing the symptom has never been the most important function of the treatment and so Jacques Lacan could speak of the “cure as surplus.” However, patients do have every right to expect relief from the psychic suffering that led them to analysis in the first place, alongside the capacity to better manage the pathological responses that the vagaries of life engender through the repetition compulsion.

The extension of psychoanalytic treatment to more severe pathologies, to borderline conditions and psychotic disorders, has altered both the notion of its outcome and the means by which it is reached. Freud’s formulation “Where id was, there shall ego [or ‘I’] be (*Wo Es war soll Ich werden*)” and its possible translations has produced a range of possible interpretations according to whether the Freudian *Ich* is translated as “ego,” as in ego psychology for example, or as “I,” as in the “subject.”

However, the termination of treatment does not mark the end of the analytic process; its ongoing working-through continues in self-analysis and in the return to the couch, of either the same psychoanalyst or of another, or to an analyst of the other sex or to one from a different school.

ALAIN DE MIJOLLA

*See also:* Abstinence/rule of abstinence; Active technique; Analyzability; “Analysis, Terminable and Interminable”; Biological bedrock; Cure; Face-to-face situation; Framework of the psychoanalytic treatment; Free association; Fundamental rule; Indications and counterindications for psychoanalysis; Initial interviews; Lay analysis; “Lines of Advance in Psycho-Analytic Therapy”; Money and psychoanalytic treatment; Neutrality, benevolent neutrality; Techniques with adults, psychoanalytic; Techniques with children, psychoanalytic; Termination of treatment; Training of psychoanalysts; Training analysis; Transference.

### **Bibliography**

Cahn, Raymond. (1996). *La cure psychanalytique*. Paris: Presses Universitaires de France.

- Freud, Sigmund. (1900a). The interpretation of dreams. *SE*, 4–5.
- . (1904a). Freud's psychoanalytic procedure. *SE*, 7: 247–254.
- . (1905e [1901]). Fragment of an analysis of a case of hysteria. *SE*, 7: 1–122.
- . (1913c). On beginning the treatment. (Further recommendations on the technique of psycho-analysis I). *SE*, 12: 121–144.
- . (1937c). Analysis terminable and interminable. *SE*, 23: 209–253.
- . (1937d). Constructions in analysis. *SE*, 23: 255–269.
- Freud, Sigmund, and Breuer, Josef. (1895d). Studies on hysteria. *SE*, 2: 48–106.
- Glover, Edward. (1955). *The technique of psycho-analysis*. London: Bailliere, Tindall and Cox.
- Greenson, Ralph R. (1967). *The technique and practice of psychoanalysis*. New York: International Universities Press.
- Grunberger, Béla, and Chasseguet-Smirgel, Janine. (1980). *La cure psychanalytique. Sur le divan*. Paris: Tchou.
- Mijolla, Alain de. (1987). De la pratique psychanalytique de Freud à la nôtre. *Études Freudiennes*, 30, 17–37.

### Further Reading

- Rangell, Leo. (1996). The “analytic” in psychoanalytic treatment: How analysis works. *Psychoanalytic Inquiry*, 16, 140–166.
- Rothstein, Arnold, ed. (1988). *How does treatment help? On the modes of therapeutic action of psychoanalytic therapy*. Madison, CT: International Universities Press.

## PSYCHO-ANALYTICAL TREATMENT OF CHILDREN, THE

This book brings together three works written during the years 1926–1945. It thus offers a longitudinal and dynamic view of Anna Freud's basic theoretical positions regarding the technique of child analysis and, in Anna Freud's own words, “attempts to summarize some of the advances in the understanding and evaluation of the infantile neurosis which the author has made in the [last] nineteen years of work on the subject” (p. ix). Inevitably, this volume reflects the controversies and conflicts that opposed the author's

approach to that of Melanie Klein, who is in fact cited repeatedly throughout.

The first part of *The Psycho-Analytical Treatment of Children* is comprised of four lectures given at the Vienna Institute of Psycho-Analysis in 1926 under the general title “Introduction to the Technique of the Psycho-Analysis of Children.” Here Anna Freud exposes her views of that time on the preparatory phase of child analysis (Lecture 1), on technique (Lecture 2), on the role of transference (Lecture 3), and on the relationship between the analysis of children and their upbringing (Lecture 4). The second part of the book, “The Theory of Children's Analysis,” a paper read to the Tenth Psycho-Analytical Congress at Innsbruck in 1927, takes up the same theme, while the third part, the latest, is mainly concerned with indications for the psychoanalytic treatment of children.

Three main themes can be identified in this work. The first concerns the techniques used in child analysis, where, in contrast with adult analysis, free association does not play a central role; nor does dream interpretation, which in the case of children is therefore not the “royal road” to the unconscious. Play and drawing are considered to be indispensable tools, though she conceives of them far more as techniques for “observing” the child than as sources of directly interpretable material. Indeed the analyst is described by Anna Freud as an “observer,” very close to the child, who relies on the words of the parents and their wish for the child to be treated. The child is not considered capable of being conscious of its illness, nor, therefore, of asking for help, whence the need for the analyst actively and deliberately to induce the young patient to accept “a tie between us which must be strong enough to sustain the later analysis” (p. 11).

The issue of the child's participation in the analysis raises the problem—a central one in the dispute between Anna Freud and Melanie Klein—of the child's ability to establish a transference during analytic treatment, and this question is the second essential theme of this book. Despite some evolution in her thinking, and even if she acknowledged the possibility of some manifestations of transference with children, Anna Freud always maintained that it was impossible for a childhood neurosis to be supplanted by a transference neurosis, that is, by a new neurotic formation in which the analyst replaces the “original objects” in the child's emotional life, namely the parents (p. 34). Inasmuch as the child continues to experience its parents as love-

objects in reality, the analyst can play a role only as an addition to, and not as a replacement for, those relations.

The third and last main theme here, dealt with mainly in the last part of Anna Freud's book, in her discussion of the indications for child analysis, concerns the distinction between normal and pathological development, between transient symptoms and real obstacles to development, between the equilibrium of defense mechanisms and the overwhelming of those mechanisms, and, finally, the relations between infantile neurosis and the formation of the ego. These are matters also discussed elsewhere by Anna Freud, as for example in *The Ego and the Mechanisms of Defence* (1936) or *Normality and Pathology in Childhood* (1965), along with, notably, the idea of "lines of development." Anna Freud thus contributed to the attenuation of an over-mechanical view of the Freudian "stages" of emotional development, laying the stress instead on a more dynamic and less linear vision of the child's mental functioning. She also emphasized the part played by reality in the psychoanalytic treatment of children, notably the importance of an alliance with the parents and of their evolving attitudes and support during the course of their child's treatment—ideas that have lost none of their present-day relevance.

FRÉDÉRIQUE JACQUEMAIN

See also: British Psycho-Analytical Society; Freud, Anna; Great Britain; Technique with children, psychoanalytic.

### Source Citation

Freud, Anna. (1946 [1926–45]). *The psycho-analytical treatment of children*. (Parts 1 and 2; Nancy Procter-Grigg, Trans.). London: Imago; New York: International Universities Press.

### Bibliography

Freud, Anna. (1937 [1936]). *The ego and the mechanisms of defence* (Cecil Baines, Trans.). London: Hogarth.

——— (1965). *Normality and pathology in childhood. Assessments of development*. London: Hogarth/Institute of Psycho-Analysis.

King, Pearl H. M., and Riccardo Steiner. (1991). *The Freud-Klein controversies 1941–1945*. London/New York: Tavistock/Routledge.

### Further Reading

Cohen, J. (1997). Child and adolescent psychoanalysis: research, practice, and theory. *International Journal of Psychoanalysis*, 78, 499–520.

---

## PSYCHOANALYTISCHE BEWEGUNG, DIE

In 1929 Adolf J. Storfer founded the review *Die Psychoanalytische Bewegung* (The psychoanalytic movement) as one of the publications of the Internationaler Psychoanalytischer Verlag. As its title suggests, this bimonthly periodical was intended to open the frontiers of the institutionally contained psychoanalytic world to a broader non-specialist public. As a link between the science of psychoanalysis and a public with an interest in the literature, this periodical saw itself as a forum for somewhat unorthodox propositions and ideas.

This orientation was already clear in Thomas Mann's contribution to the first issue, "Die Stellung Freuds in der modernen Geistesgeschichte" (The place of Freud in the history of modern thought). Mann described Freud as a writer and scientist with a worldwide reputation whose scope and range far exceeded the universe of specialist psychologists and who was well on the way to revolutionizing all sciences of the mind. In addition to contributions from applied psychoanalysis, the review also brought together reviews of contemporary literature in the domain, as well as short literary or scientific works dating from an earlier period and considered to be precursors of psychoanalysis. In this category of genealogical precursors it published extracts from poets, such as Boccaccio, or thinkers and philosophers like Plato, Kierkegaard, Montesquieu, and Montaigne. It also presented critical points of view from contemporary writers like André Maurois, Italo Svevo, Arnold Zweig, and Stefan Zweig. The section entitled "Das Echo der Psychoanalyse" provided information on events in the world of psychoanalysis and reviewed recent political and scientific critiques of psychoanalysis in various sectors.

After Storfer resigned from the Internationaler Psychoanalytischer Verlag, Eduard Hitschmann took over the publication in August 1932. The number of subscribers to the periodical dropped after the National Socialist party came to power in Germany,

when many German analysts and intellectuals close to analytic circles fled the country. The economic and political situation caused the publication of *Die Psychoanalytische Bewegung* to be suspended in December 1933.

LYDIA MARINELLI

See also: Goethe Prize; Internationaler Psychoanalytischer Verlag.

## PSYCHOBIOGRAPHY

The term *psychobiography* in its broadest sense designates any approach to biography that emphasizes inner life and psychological development, but in the more specific sense, it means the use of a formalized psychological theory and concepts in writing biography, and it received its decisive impetus from psychoanalysis. Psychobiography in the broad sense goes back at least to Plutarch, but Freud's book on Leonardo's childhood (1910) is often seen as one of the first to apply a formalized metapsychology.

Although many biographies in the past had dealt with psychological development, the arrival of psychoanalysis in the twentieth century has offered a comprehensive psychological theory of early human development that explains the shaping of the life course. Psychobiography generally focuses on the formative early years of life in an effort to uncover the relational dynamics, traumas, or complexes that might explain later behavior.

Psychobiography is a major instrument of psychohistory for the study of leading historical figures. But the two are not identical since psychohistory is especially concerned with group behavior.

The focus of psychoanalysis on the first few years of life has led to the sharpest criticisms of psychoanalytic psychobiography. The most often heard objections center around the charge of reductionism. First, psychobiography is criticized for its focus on psychological factors to the exclusion of cultural, social, economic, and other external factors. Psychoanalytic psychobiography in particular is often accused of reducing the subject's life to determination by complexes established in the first few years of childhood, e.g., fixation on the oral or anal stage or to a failure to successfully pass the oedipal period. Critics also point out that reliable evidence on early childhood is often almost impossible to obtain. As a result of the absence of data,

many psychoanalytic biographers have used theory to project an image of what the subject's infancy must have been like. This practice has brought especial discredit on the psychoanalytic approach since it is accused of inventing facts. A fourth objection holds that psychoanalytic biography lacks the central tool of psychoanalysis in the clinical setting—free association. Finally, there is the moral objection that psychoanalytic approaches have often denigrated the memory of great men and women by portraying them in terms of pathology or unresolved infantile conflicts.

Obviously, the more sensible and cautious psychobiographers have avoided reductionistic claims. The best psychobiographies also avoid over-confident assertions about the existence of childhood events based only on the evidence of adult behavior. The absence of a living subject's "free association," however, is viewed as less of a handicap than critics assert because the psychoanalytic biographer can often draw upon an abundance of diaries, letters, and other writings as well as sound recordings, photographs, and films for more recent subjects. Finally, to the objection that psychobiography maligns the reputation of exemplary figures, one may reply that the same objection can be made to any critical biography which explores the determination of character.

Many of the standard objections to psychoanalytic biography are also mitigated by the application of those psychoanalytic theories which place greater emphasis on ego development. In some versions of ego psychology the personality is said to continue to develop across the life span with the possibility that later experiences can modify processes rooted in early childhood. According to such perspectives there are important psychological stages and tasks to be accomplished beyond the oedipal period, as illustrated in Erik Erikson's *Gandhi's Truth*, which deals with a crisis in Gandhi's mature years. In the early twenty-first century, psychoanalytic theories provide a variety of perspectives that can illuminate all stages of the life span, accounting for psychological health and triumph as well as the persistence of destructive traits fixed in infancy.

LARRY SHINER

See also: "Claims of Psycho-Analysis to Scientific Interest"; History and psychoanalysis; *Leonardo da Vinci and a Memory of His Childhood*; *Life and Works of Edgar Allan Poe: A Psychoanalytic Interpretation*; Psychohistory; Psy-

*chopathologie de l'échec* (Psychopathology of Failure); Thomas Woodrow Wilson, *Twenty-eighth President of the United States. A Psychological Study*; Visual arts and psychoanalysis.

### **Bibliography**

- Erikson, Erik H. (1969). *Gandhi's truth*. New York: W. W. Norton.
- Freud, Sigmund (1910). Leonardo da Vinci and a memory of his childhood. *SE*, 11: 57–137.
- Runyan, William McKinley (1982). *Life histories and psychobiography. Explorations in theory and method*. New York: Oxford University Press.
- Strozier, Charles B. (1982). *Lincoln's quest for union. Public and private meanings*. New York: Basic.
- Tucker, Robert C. (1973). *Stalin as revolutionary, 1879–1929. A study in history and personality*. New York: W. W. Norton.

### **Further Reading**

- Mijolla, Alain de. (1996). Psychoanalysts and their History. *International Psychoanalysis: The Newsletter of the IPA*, 5 (1), 25–28.
- . (1998). Freud, biography, his autobiography, and his biographers. *Psychoanalysis and History*, 1 (1), 41.

## **“PSYCHOGENESIS OF A CASE OF HOMOSEXUALITY IN A WOMAN, THE”**

The treatment that Sigmund Freud relates in the article “The Psychogenesis of a Case of Homosexuality in a Woman” was a short one, lasting four months. He had broken it off one year or so earlier, upon recognizing the force of his patient’s negative transference towards him.

Then aged nineteen years old, the young girl did not consider herself to be in any way ill and had only agreed to begin an analysis at her father’s insistence. Her father was worried not only about his daughter’s overt homosexuality but in particular about a recent suicide attempt; after he had encountered her in the street in the company of the woman with whom she was in love, she had thrown herself over a parapet wall on to a suburban railway line.

The second child and sole daughter of a family of four children from the Jewish bourgeoisie in Vienna, “assimilated” by baptism, the young girl had fallen passionately

in love with a “*cocotte*” who was ten years older than she. In desperation, the family had decided to appeal to Freud, despite what he describes as the low esteem in which psychoanalysis was then generally held in Vienna.

This is the only case of female homosexuality that Freud reports and the analysis was conducted during a period when his daughter Anna, then aged twenty-four years old, was also in analysis with him. This text could be considered as the starting-point for a development in Freud’s study of femininity, as he later elaborated it in “Some Psychical Consequences of the Anatomical Distinction between the Sexes” (1925j), “Female Sexuality” (1931b), and “New Introductory Lectures on Psycho-Analysis” (1933a).

“The Psychogenesis of a Case of Homosexuality in a Woman” is noteworthy in that it simultaneously concerns:

- Clinical questions: homosexuality in women but also in men; the concept of object-choice in relation to the Oedipus complex; the status of dreams with regard to the unconscious; adolescence and passage to the act; and suicide.
- Technical observations on the treatment: the negative therapeutic reaction; the transfer of oedipal hostility onto the analyst; the therapeutic alliance; and the difficulty with analysis conducted at the request of a third party.
- Epistemological developments: causality in the analysis and its unpredictability; innate and acquired characteristics; and the connections between psychoanalysis and biology.

It therefore becomes apparent once again how it is difficulty or even failure in clinical practice that lead Freud to reflect in a productive way, as is characteristic of scientific investigation.

Freud addresses the question of homosexuality from the outset of his work in many texts. He emphasizes here that “it is not for psycho-analysis to solve the problem of homosexuality” (1920a, p. 171); that is, he considers it to be a variant of the sexual organization that in common with heterosexuality represses the other part of the original bisexuality. For him, the analytic attitude consists in re-establishing the full bisexual function in a way that leaves open the subsequent choice.

The complex relations between object choice and identification with the object are demonstrated here:



disappointed in her oedipal love by the birth of a new brother when she is in the throes of the pubertal resurgence of the Oedipus complex, the young homosexual girl turns away from her father and from men in general. She identifies with her new brother and takes first her mother and then another woman as love object in place of her father.

Rather than the oedipal competition, Freud emphasizes here the negative consequences of the “libidinal withdrawal” as a convenient position that avoids the conflict. He also resumes and continues his analysis of the origin of the compulsion to fall in love with women of “ill repute” who need to be “saved” (1910h).

Previously analyzed (1910g), suicide is emphasized here in its primary murderous and other-directed nature, which is secondarily turned back on the subject herself by identification. It is surprising, however, that the young girl’s passage to the act, which she explains by her despair in love following her rejection by the woman who evidently did not want any trouble with the family, is not discussed any further by Freud—particularly in its dual character of destructiveness both toward the mother, represented by the loved and rejecting woman (who “drops” her), and toward the father against whom the act is directed as a supreme act of defiance.

The idea that the patient is attempting to mislead him with lying dreams leads Freud to an important observation that the dream is not the “unconscious” but the form into which a thought left over from conscious or preconscious waking life is recast.

This is to be understood in the context of the patient’s negative transference and resistances, which he likens to Russian military tactics of encouraging the enemy to advance in order to ambush him later. Realizing that the patient has transferred to him “the sweeping repudiation of men which had dominated her ever since the disappointment she had suffered from her father” (1920a, p. 164), Freud breaks off the treatment and advises that she should resume it with a woman analyst.

In his view, the young girl has therefore proved incapable of successfully completing the second phase of the analysis, which follows the period in which information is obtained and is supposed to lead the patient herself to grasp hold of the material placed at her disposal. These technical observations had already

appeared in another form in the concept of working-through (1914g).

Finally, the question of homosexuality leads Freud to distance himself from the received idea of a congenital homosexuality and to emphasize, alongside the somatic sexual characteristics and the type of object-choice, the importance of the psychic sexual characteristics—that is, the “masculine and feminine positions”—leaving the rest to biological research.

This article is therefore an important clinical, technical and epistemological work.

The therapeutic failure is productive not only because it leads Freud to reconsider the procedure of both analyst and analysand in the treatment, particularly in its beginnings, but also because it leads him to identify in part with the question posed by the parents: what should be done with regard to this young girl’s homosexuality and, above all, could it have been foreseen and therefore avoided?

This concerns a fundamental question for psychoanalysis, to which Freud gives a firm answer: “Hence the chain of causation can always be recognized with certainty if we follow the line of analysis, whereas to predict along the line of synthesis is impossible” (1920a, p. 168).

There are so many causal factors at work that it is impossible to know in advance which will prove to be the strongest. The concept of “deferred action” that characterizes the specific nature of temporality in psychoanalysis emerges here in its epistemological dimension: prediction is impossible because it is only in deferred action that it can be said which elements were the strongest, for the sole reason that it is these that have prevailed. Although it may seem a truism, this observation is nevertheless of fundamental importance for child and adolescent psychology and it conflicts with primary pseudo-determinism.

On the ethical plane, it is also a perspective that leads to an active attitude of confidence in the possibility that psychic destiny is not fixed for all time. In fact, Freud does not take the view that homosexuality is a sexual pathology, although he does emphasize that female homosexuality is “much less glaring” than male homosexuality and that it is beyond the purview of the law.

Despite his annoyance at not managing to get through his young patient’s defenses and polite con-

tempt, Freud in fact appears respectful of her choices and firm with regard to the ethics of the analytic position, in which there is no question of defining a “good” sexuality to be imposed on the ailing “deviant.”

A fascinating biography of the patient, Sidonie Csillag, was published in 2000 by Ines Rieder and Diana Voigt. It provides us with a useful reminder of the context of female homosexuality in this period and bisexuality as a phenomenon that accompanied women’s emancipation. The book sheds light on the unusual fate of this woman, who was to die a centenarian, after leading a life that was as free, non-conformist, and adventurous as the one that had led her to Freud against her will at the age of nineteen.

SOPHIE DE MIJOLLA-MELLOR

*See also:* Adolescence; Adolescent crisis; Female sexuality; Femininity; Feminism and psychoanalysis; Homosexuality; Masculinity/femininity; Negative therapeutic reaction; Negative transference; Psychic causality; Resistance; Sexuality; Sexualization; Sexuation, formulas of; Suicide.

### Source Citation

Freud, Sigmund. (1920a). Über die Psychogenese eines Falles von weiblicher Homosexualität. *Internationale Zeitschrift für Psychoanalyse*, VI, 1920, pp. 1–24; *GW*, XII, pp. 271–302; The psychogenesis of a case of homosexuality in a woman. *SE*, 18: 145–172.

### Bibliography

Freud, Sigmund. (1925j). Some psychical consequences of the anatomical distinction between the sexes. *SE*, 19: 241–258.

———. (1931b). Female sexuality. *SE*, 21: 221–243.

———. (1933a [1932]). New introductory lectures on psycho-analysis. *SE*, 22: 1–182.

Rieder, Ines, and Voigt, Diana. (2000). *Heimliches Begehren: Die Geschichte der Sidonie C. Franz*. Vienna/Munich: Deuticke Verlag.

## PSYCHOGENESIS/ORGANOGENESIS

The notions of *psychogenesis* and *organogenesis* come out of a classic debate in the field of psychology—a debate that, throughout history, has taken the form of

a dichotomy between innate and acquired or subjective and objective. Today, its most radical form is illustrated in the opposition between neuronal and mental. These two notions are usually associated with causal deterministic or etiopathogenic types of mental disorders.

Classically, *psychogenesis* of a mental problem is understood to mean an etiological or etiopathogenic process that is exclusively supported by events or mechanisms of a mental nature and outside of any organic factor, especially those affecting the nervous system or the brain. Psychoanalysis, as a theory of the human mind based on exploration of the unconscious, for a long time represented and illustrated the psychogenetic point of view within psychology by emphasizing the dynamics of unconscious conflict. Some doctrinal trends within contemporary psychoanalysis, such as the current informed by the work of Jacques Lacan, radicalized this viewpoint through the use of a formalization of the structures of language in relation to the unconscious.

By contrast, *organogenesis* of a mental problem is understood to mean an etiological or etiopathogenic process grounded in an organic dysfunction. While in the late nineteenth and early twentieth centuries organic dysfunction was conceived in terms of lesions of certain areas of the brain according to an anatomical model, present-day contributions from molecular biology, genetics, and, above all, the neurosciences have instead situated such dysfunction within the neuronal connections that make up the structures of the brain. Certain currents within psychology, such as those derived from neuropsychobiological, experimental, or cognitive approaches, by privileging the objective dimension within observation protocols and data collection, illustrate this organogenic point of view.

From a psychoanalytic point of view, the debate between psychogenesis and organogenesis can no longer be treated schematically and exclusively. This debate raises the question of psychic causality, the affirmation of which is indissociable from psychic reality. According to Freud’s conception, mental life is necessarily grounded in organic life, but there is a limit beyond which psychoanalytic inquiry can no longer be relevant. Following up from that viewpoint, today one can say that mental functioning is grounded in brain functioning, but that it does not derive directly from, nor is it reducible to, brain functioning. The logic of

the mental thus remains heterogeneous to the logic of the neuronal, as is shown, in particular, by its theoretical referents. Notions such as the drive—with its two polarities, somatic and psychic—or representation, as well as modern psychoanalytic studies on borderline states or psychosomatic states, which emphasize symbolic transformations (meaning) and economic transformations (force) attest to a specifically mental reality that has its own causality.

At the margins of the psychogenetic and organogenetic points of view, one current of doctrine, the organodynamic current, attempted to make a synthesis between the two. An outgrowth of the work of the neurologist John Hughlings Jackson, and based on a hierarchical, evolutionary conception of the structures of the nervous system, this trend was applied in the field of psychopathology, specially by Henry Ey and others. In this conception, it is posited that mental disorders are linked to dissolution or disorganization at a certain level of mental organization, by means of damage of organic origin that generates negative symptoms, and to reorganization at an inferior level, linked to mental life's characteristic dynamism and ability to generate positive symptoms. In the field of psychosomatic phenomena, Pierre Marty applied this model in an original and personal way to the psychosomatic economy and its disorders.

CLAUDE SMADJA

*See also:* Constitution; "Heredity and the Aetiology of the Neuroses"; Heredity of acquired characters; Organic repression; *Phylogenetic Fantasy, A: Overview of the Transference Neuroses*; Psychic causality; Psychotic/neurotic.

### **Bibliography**

- Changeux, Jean-Pierre. (1983). *L'Homme neuronal*. Paris: Fayard.
- Ey, Henry. (1973). *Traité des hallucinations*. Paris: Masson.
- Freud, Sigmund. (1893c). Some points for a comparative study of organic and hysterical motor paralyses. *SE*, 1: 155–172.
- . (1910i). The psycho-analytic view of psychogenic disturbance of vision. *SE*, 11: 209–218.
- Marty, Pierre. (1980). *Les Mouvements individuels de vie et de mort. I, L'Ordre psychosomatique*. Paris: Payot.

## **PSYCHOGENIC BLINDNESS**

Psychogenic blindness, whether it arises from too great a desire to see or from a refusal to see, had psychological causes for Freud. Here, as elsewhere, hysteria was Freud's guide: it was apropos of hysteria that he broached the subject of conflict between the various visual functions, and he placed the eye (the source of visual pleasure) and the act of looking itself at the center of his thinking.

His study "The Psycho-Analytic View of Psychogenic Disturbance of Vision" (1910i) dealt specifically with blindness that had its origin in hysteria. He noted that hypnosis could be used to induce blindness experimentally by suggesting to the subject not to see anything, but that in hysterical patients the idea of being blind did not proceed from third-party suggestion but arose spontaneously from autosuggestion. Hence his question: when and under what conditions does an idea become so powerful that it behaves like a suggestion and becomes a reality? For Freud "hysterically blind people are only blind as far as consciousness is concerned; in their unconscious they see" (p. 212): the stimuli reaching the blind eye arouse unconscious affects.

Certain ideas associated with vision remain separate from consciousness: they have succumbed to repression because they conflict with other, stronger ideas that dominate the ego. Such conflicts between ideas are simply an expression of the conflict between instincts, especially between the sexual instincts and the ego instincts, both of which use the same organs of the body. Thus the eyes perceive not only the modifications to the outside world that are important for preserving life, but also the characteristics and attractions of the love object. But it is not easy to serve two masters: the more that an organ with this dual function enters into an intimate relation with one of the two great instincts, the more likely it is to refuse itself to the other. This can have pathological consequences if the two basic instincts are disunited, if, for example, the partial sexual instinct that uses the eyes makes excessive demands. These excessive demands disturb the relation of the eyes and the act of seeing to the ego, because the ideas linked to these demands succumb to repression and are excluded from consciousness. This circumstance may attract a counterattack from the ego instincts.

When the sexual interest of sight, *Schaulust*, becomes too insistent, the ego no longer wants to see anything,

and the visual organ, using its power to separate, puts itself entirely at the disposal of the sexual instinct in the unconscious. Because the ego then no longer has conscious control over the organ, the repression miscarries, and a substitute mechanism converts the repression into blindness. This blindness seems to be the result of an implacable psychic logic: by seeking to misuse the visual organ for purposes of sexual pleasure, subjects condemn themselves to see only the sexual on the unconscious stage and otherwise to see nothing.

When Freud tackled the question of the uncanny (1919h), he mentioned E. T. A. Hoffmann's tale *The Sandman*, in which a character plucks out children's eyes to graft them onto automatons. This story, he felt, lent support to his view that the feeling of uncanniness is directly related to the sight of the female genitals, particularly those of the mother. He stressed the frequent unconscious equivalence between the eyes and the genital organs, and between blindness and castration. Blinding oneself, like Oedipus, is an attenuated form of self-castration, but it also makes one the bearer of a blind eye, which represents the other sex while disfiguring the face. In his theory, Freud, with a single word, *übersehen*, which means both to look and to overlook, successfully condensed the story of Oedipus.

Blindness is thus the result of a punishment, but what is the nature of the offense? The hysteric's blindness seems to play out the Oedipus complex quite literally. For one, it chooses a substitute organ, the eye, which stands at once for the castrated sexual organ and the desired sexual organs of the mother. Moreover, it makes the eye into the special object of the desire to see, as though it were obliged to reduce the sexual organ to the eye and were subject to the autoerotic need for the eye to derive pleasure from the eye.

JEAN-MICHEL HIRT

*See also:* Castration complex; Hysteria; Look/gaze; Psychic causality; Psychogenesis/organogenesis; Scopophilia/scopophilia; Visual.

### **Bibliography**

Freud, Sigmund. (1910i). The psycho-analytic view of psychogenic disturbance of vision. *SE*, 11: 209–218.

———. (1919h). The “uncanny.” *SE*, 17: 217–256.

Rey, Jean-Michel. (1979). *Des mots à l'œuvre*. Paris: Aubier-Montaigne.

## **PSYCHOHISTORY**

Psychohistory may be defined as the application of formal psychological models in historical research. The modern field known as psychohistory is usually dated from the appearance of Freud's book on Leonardo (1910), although the term *psychohistory* did not come into use until the 1960s. Although scattered attempts at the application of psychoanalytic theories to history were made between 1910 and 1940, the rise of Hitler and National Socialism led to a renewed interest in understanding irrational motivation. This was particularly true in the United States, where William L. Langer became president of the American Historical Association in 1958 and called for psychoanalytic methods to replace amateur psychologizing in historical research. That same year Erik Erikson published his widely read *Young Man Luther: A Study in Psychoanalysis and History*. As a result of Langer's and Erikson's influence many younger scholars turned to psychohistory, as the new field was soon nicknamed.

Although the fields of psychohistory and psychobiography are closely related, psychohistory limits itself to important historical figures like Richelieu, Hitler, or Wilson, and attempts to go beyond individual psychology to group behavior. Many historians regard the real test of the utility of psychoanalysis for history to be its success in explaining group behavior. A number of recent psychoanalytic studies, such as Robert Jay Lifton's *The Nazi Doctors*, have attempted to explain group behavior in extreme historical situations. The witchcraft trials of the seventeenth century have also provided a fruitful subject for the study of group behavior, as in John Demos's *Entertaining Satan* (1982) on New England or Lindal Roper's *Oedipus and the Devil* (1993) on southern Germany.

Psychohistory has been controversial within the history profession from its beginnings, but particularly after it became a prominent sub-field within academic history in the United States. Attacks on psychohistory have been of two kinds. One kind assails the careless research methods and hasty conclusions reached by some authors, particularly by clinicians not trained in historical method or by historians who misunderstand and misapply psychoanalytic concepts. The second

kind of objection to psychohistory involves specific problems such as the role of individuals in history compared to larger social and economic forces, the charge of reductionism and the importance of acknowledging possible alternative explanations, the difficulty of “analyzing” the dead from scant evidence of childhood experiences, and, finally, questions concerning the validity of psychoanalytic theory itself. Although there are reasonable answers to each of these problems, some academic historians remain hostile to psychohistory.

Perhaps the most important reply to the general antagonism toward psychohistory is that since history has accepted models and theories drawn from the other social sciences (sociology, anthropology, economics), historians should not continue to use amateur psychology but draw on explicit psychological models. Of course, there can be a non-psychoanalytic psychohistory and even among those historians sympathetic to psychoanalysis there are many differences in approach, some following traditional instinctual models, others some form of object relations, and an increasing number pursuing ego psychology models like that of Heinz Kohut.

Some have suggested that methodological problems could more easily be avoided if psychohistorians received professional training in both history and psychoanalysis and there are a number of present-day historians who not only have doctoral degrees in history but are certified by one of the psychoanalytic institutes. In the United States a number of psychohistorians hold teaching and research positions in universities and offer doctoral training to younger scholars. Two journals exist, *The Journal of Psychohistory*, which primarily publishes the work of practicing clinicians, and *The Psychohistory Review* which publishes the work of historians and clinicians concerned to meet the standards of academic history. Despite some continuing resistance, psychohistory in the broadest sense is an established part of academic history in the United States and to a lesser degree in Germany and Israel. It has made its way more slowly in Britain and France.

LARRY SHINER

See also: Collège de psychanalystes; Erikson, Erik Hom-burger; Politics and psychoanalysis; Psychobiography.

### Bibliography

- Friedländer, Saul (1975). *Histoire et Psychanalyse. Essai sur les possibilités et les limites de la psycho-histoire*. Paris: Le Seuil; translated by Susan Suleiman as *History and psychoanalysis: An inquiry into the possibilities and limits of psychohistory*. New York: Holmes and Meier, 1978.
- Gay, Peter (1985). *Freud for historians*. New York: Oxford University Press.
- Loewenberg, Peter (1985). *Decoding the past: The psychohistorical approach*. New Brunswick, NJ: Transaction.
- Marvick, Elizabeth (1985). The “Annales” and the unconscious: Continuity and contrast within an historical school. *Psychohistory Review*, 13, 42–52.
- Runyan, William McKinley (1988). *Psychology and historical interpretation*. New York: Oxford University Press.

### Further Reading

- Mijolla, Alain de. (1996). Psychoanalysts and their history. *International Psychoanalysis: The Newsletters of the IPA*, 5 (1), 25–28.

---

## PSYCHOLOGICAL TESTS

Psychological tests are those that are designed to reveal individual modes of psychological functioning. Some of these are subject to strict codification and numerical evaluation that afford an assessment of individual performance in relation to a standard. Others use more flexible techniques and do not have recourse to quantification: the expression “projective personality assessment” is often then used rather than “test.” This expression is applied to so-called expressive and “projective” evaluations, the only ones to bear—often, though not always—the mark of some aspect or another of psychoanalytic theory.

Hermann Rorschach, a Swiss psychiatrist trained in the Burghölzli clinic directed by Eugen Bleuler, was the first to imagine this type of test when he had the idea of asking his patients what they saw in inkblots. This test, which has given rise to innumerable publications, is the most commonly used. In his theoretical views, Rorschach himself was no doubt more influenced by Bleuler and Gustav Jung than by Sigmund Freud, although some of his successors have tried to fit him into coherent psychoanalytic thinking (Anzieu and Chabert, 1997).

Another type of assessment derives from the line of approach begun by Henry Murray in 1935 with the Thematic Apperception Test, or TAT. In these thematic tests the subject is presented with plates (or photographs) presenting one or more characters engaged in a situation and an action that the subject is asked to imagine. Leopold and Sonya Soral Bellak constructed a version for children in which the plates represent humanized animals (Children's Apperception Test, or CAT). Many other evaluations using the same principle have been put forward (like Louis Corman's Black Paw, Roger Perron's Personal Dynamic and Images).

A great many assessments have been imagined using different principles, almost always in a psychoanalytic context: sentences to complete and stories to complete (Madeleine Thomas); fables in which the person being tested has to comment on the moral (Louisa Düss); stories to create and tell with the material support of dolls (Gertrude von Staabs), characters, elements of a village (Henri Arthus, Pierre Mabile); interpretation of the expressions on human faces in photographs (Leopold Szondi). Saul Rosenzweig's Frustration-Aggression test no doubt deserves special mention because it is built explicitly on the basis of a hypothesis derived from psychoanalysis ("frustration produces aggression"). It met with great success in the world of American experimental psychology between the two wars.

Lastly, we must accord a special place to "expressive" techniques that interpret the content and style of speech, walking, gestural behavior, but most of all graphic behavior: writing, but above all drawing, a procedure that Françoise Dolto in particular demonstrated (*Le Dessin de l'Enfant*, 1996).

These techniques are said to be "projective," based on the hypothesis that what the subject "perceives" of the material presented (which is preferably ambiguous and open to multiple interpretations in terms of graphics, situation, and so on) is in fact indicative of the subject's representations of the world, people, interpersonal relations and, definitively, of the subject's own psychic functioning. This often supposes a fairly psychologized and simplified definition of the psychoanalytic notion of projection, although certain authors prefer to use the notion of *identification*, which is also every bit as complex in psychoanalytic theory. Theoretical simplification always runs the risk of resulting in relatively simplistic interpretation procedures. Correct use of these techniques presupposes a solid grounding in clinical psychology and psychopathology, as well as specialized training.

Under these conditions, projective tests constitute an important instrument for contributing to psychological and psychopathological diagnostics.

ROGER PERRON

*See also:* Psychological types (analytical psychology); Psychology and psychoanalysis; Rorschach, Hermann; Szondi, Leopold; Word association.

### **Bibliography**

Anzieu Didier, and Chabert, Catherine. (1997). *Les méthodes projectives*. Paris: Presses Universitaires de France.

Brelet, Françoise. (1986). *Fantasme et Situation projective*. Paris: Dunod.

Raffier-Malosto, Jocelyne (Ed.). (1996). *Le Dessin de l'enfant. De l'approche génétique à l'interprétation clinique*. Paris: La Pensée Sauvage.

### **Further Reading**

Schafer, Roy. (1967). *Projective testing and psychoanalysis: Selected papers*. New York: International Universities Press.

Sugarman, Alan, and Kanner, K. (2000). The contribution of psychoanalytic theory to psychological testing. *Psychoanalytical Psychology*, 17, 3–23.

---

## **PSYCHOLOGICAL TYPES (ANALYTICAL PSYCHOLOGY)**

Carl Jung's discrimination of human consciousness according to its functions (thinking, feeling, sensation, and intuition) and habitual attitudes (extraversion and introversion) was his attempt to provide a psychology of experience with a critical orientation in sorting out the empirical material of psychic dispositions, tendencies, and convictions. Jung's first presentation of the idea of psychological types was in a lecture delivered at the Psychoanalytical Congress in Munich during September 1913. He noted the striking difference in attitude toward the external world between patients diagnosed with hysteria and those diagnosed with schizophrenia in terms of intensity of feeling, the former displaying an exaggerated emotivity with regard to the environment and the latter an extreme apathy. He also noted characteristic differences in thought content: the fantasy life of the patient with hysteria may be accounted for in a natural and

human way by the antecedents and individual history of the patient, whereas the patient with schizophrenia consciously experiences fantasy closer to dreams than to the psychology of the waking state in having a distinctly archaic character, with mythological creations more in evidence than the personal memories of the patient.

From these facts, Jung concluded that hysteria is characterized by a centrifugal movement of libido, which he called *extraversion*, and schizophrenia by a contrary movement, which he called *introversion*, toward the core of the personality (which he later called *the self*). Although Jung recognized that in these two clinical syndromes he was witnessing regressive extraversion and regressive introversion, he nevertheless concluded that there was in the development of consciousness a normal distinction between the two movements of libido. Extraversion, he postulated, tends naturally to bond and even merge with objects in the outer world, while introversion naturally turns away from such objects in order to link up with the internal objects that Jung eventually called archetypes. Kenneth Shapiro and Irving Alexander have subsequently noted that these two movements of libido are constitutive of experience itself for the different types, experience only being experience for the extravert when it is shared with another person or object in the outer world and, for the introvert, when it matches up to some a priori archetypal category or capacity to experience just that type of thing. The theory of psychological types itself is an introverted way of thinking about experience and making it real, which may account for its difficulty for psychologists using an extraverted attitude.

In the years between 1913 and 1921, when the book *Psychological Types* finally appeared, Jung developed the theory to include what he called the functions of consciousness, which he named sensation, thinking, feeling, and intuition. Whether deployed toward objects in the outer world or toward the inner world of archetypes, sensation gives consciousness the practical sense that an object is really being presented to it; in other words, that it is, thinking gives it a name, feeling assigns it a value (for which reason Jung's *feeling* is sometimes replaced by analytical psychologists with the word *valuing* or with *feeling valuation*) and intuition grants consciousness a direct, uncanny perception (from the perspective of the "absolute knowledge" of the unconscious) of the

origin and fate of the object, as Jung puts it "whence it arises and where it is going."

For Jung sensation and intuition are irrational functions in being functions of perception which are irrationally "given." Thinking and feeling, by contrast, are rational functions, being choices, in the sense of judgments by consciousness, as to how to discriminate among objects that are perceived.

That individuals develop consciousness in different ways, according to their preference for using certain functions over others has led the theory of psychological types to be used to type people and to predict their likelihood to succeed in certain professions. A test based on Jung's model, known as the Myers-Briggs Type Indicator (MBTI), has had widespread use in the United States. The MBTI uses categories of judging and perceiving to distinguish Jung's rational and irrational extraverted functions. In typing the preferred mode of consciousness of an individual, an attempt is made to define the person's typical "superior function" according to whether it is extraverted or introverted, whether it is most characterized by sensation, thinking, feeling, and intuition, and whether it is rational or irrational.

There will normally be an auxiliary function that is "different in every respect" providing the individual with an alternative mode of consciousness with which to meet inner and outer situations. In depth psychological work, it is also important to define the "inferior function" which, though much less easily differentiated into a conscious competence, is the place one most often experiences unconscious complexes and conflicts.

JOHN BEEBE

*See also:* Analytical psychology; Animus-Anima; Extroversion/introversion (analytical psychology); Midlife crisis.

### **Bibliography**

- Franz, Marie-Louise von, and Hillman, James (1971). *Lectures on Jung's Typology*. New York: Spring.
- Jung, Carl Gustav (1913). A contribution to the study of psychological types. *Coll. Works*, Vol. 6. London: Routledge and Kegan Paul.
- (1921). *Psychological Types*. *Coll. Works*, Vol. 6. London: Routledge and Kegan Paul.

Myers, Isabel, and Myers, Peter (1980). *Gifts Differing*. Palo Alto, CA: Consulting Psychologists Press.

Shapiro, Kenneth, and Alexander, Irving (1975). *The Experience of Introversion*. Durham, NC: Duke University Press.

## PSYCHOLOGY AND PSYCHOANALYSIS

It is important to stress the point that for Freud himself psychoanalysis was a psychology. In 1923 he wrote: "Psychoanalysis is the name (1) of a procedure for the investigation of mental processes which are almost inaccessible in any other way, (2) of a method (based upon that investigation) for the treatment of neurotic disorders and (3) of a collection of psychological information obtained along those lines, which is gradually being accumulated into a new scientific discipline" (1923a, p. 235).

Rarely in his writings did he make any mention of contemporary work in "academic" psychology, however. He sometimes cited authors who wrote in German (Wundt, Hering, and Ehrenfels), French (Binet and Claparède), or English, like Darwin and his cousin Francis Galton, or Stanley Hall, whom he met in 1909 on his voyage to the United States, but such references remain episodic. The two most frequently cited authors are Fechner, from whom he borrowed the principle of constancy in the framework of his energy approach to psychic function, and Pierre Janet, with whom he had a long controversy based both on a conflict of prestige and priority and on a fundamental theoretical divergence: Janet explained hysteria in terms of reduced "psychic tone," whereas Freud saw the effects of conflictual tension in it.

One could therefore consider Freud to be ill informed about work by psychologists in his own time. This would probably be completely false: his interest in memory and perception fits readily into the framework of a "psychology of the faculties," which was still very much present in *Project for a Scientific Psychology* (1950c [1895]), the main points being reviewed in *The Interpretation of Dreams* (1900a). Over the years, however, his concepts, which were initially strongly influenced by the dominant empiricist associationism of the late nineteenth century, progressively evolved toward a radically different approach to memory and perception that allows for the effects of deferred action and also focuses on the psychoses and delusions (Perron). This provides a

new solution to the whole problem of the relations between the "reality of the external world" and "psychic reality," a solution that has nothing in common with the views developed elsewhere in psychology.

We must also bear in mind that while he was still at school it was from a psychologist, albeit an amateur, Herbart, that Freud acquired the fundamental ideas of psychoanalysis, ideas such as repression, the threshold of consciousness, and the unconscious (Andersson)—these were the origins of the topical model of metapsychology. The origins of the economic model can be found in the "energetic" trend that included, among others, Brücke, his mentor, and Fechner. The "dynamic" model is specifically psychoanalytic. There is also what is sometimes referred to as a "fourth point of view," the developmental perspective: case studies analyzing the stages in the development of a given child were very much in vogue in psychology between 1880 and 1930, from Baldwin and Binet to Piaget himself. With the cases of "Little Hans" and the "Wolf Man" Freud fit into this stream of ideas in his own way.

After Freud, what were and what are the influences of psychology on psychoanalysis? And conversely, what are the influences on psychology of psychoanalysis? The asymmetry is patently clear. Although certain psychoanalytic developments are deliberately based on ideas and facts coming from disciplines such as psychiatry, biology, linguistics, sociology, and ethnology, it is not easy to cite analogous importations from psychology or any of its so-called scientific branches (experimental psychology and differential psychology, for example). Perhaps the epistemological (in terms of basic postulates) and methodological gap is such that this type of importation seems unacceptable to psychoanalysts, who dread a "psychologization" that would empty metapsychology of its essential substance. In Europe, at any rate, the opposition to Hartmannian "Ego Psychology" has often been justified in this way. However, psychoanalytic theories on memory, perception, and thought processes would gain by being better informed about the current work of psychologists and neuropsychologists on these questions, and it is regrettable that they are still too often discussed in psychoanalysis in the same terms in which Freud posed them.

This discrepancy could be attributed to the "narcissism of minor differences," the separation between things that are too similar. However, it is obvious that,



seen from the reverse point of view, the influences of psychoanalysis on psychology are of major importance, in at least three respects:

- In terms of theories. Certain research trends have developed in experimental and differential psychology based on hypotheses that have been imported from psychoanalysis (albeit with distortions and simplifications): work on selective forgetting of unpleasant experiences and on aggressive behavior caused by frustration.
- In terms of techniques. Here we are referring mainly to so-called “projective” and “expressive” trials. It is important to remember that Rorschach, a psychiatrist at the Burghölzli asylum (directed by Bleuler, and where Jung also worked), created his famous ink blot test in the context of psychoanalytic ideas, as they were accepted in that institution around 1920. It is patently obvious that in recent years psychoanalytic theory has had a strong effect on this Rorschach test, as well as so-called thematic tests (Murray’s TAT), both in terms of research work and its interpretation in individual clinical practice. As for children’s drawings (classified among the “expressive” techniques), it has become commonplace though nevertheless still pertinent to interpret them in psychoanalytic terms, as Françoise Dolto illustrated particularly well.
- In more general terms, a whole new sector of psychology has developed in a context where many consider psychoanalytic references to be dominant, which creates no small difficulties for the professionals in question (Perron).

In fact, no valid questions concerning the relations between psychology and psychoanalysis can be posed without first asking: which psychology, which psychoanalysis? In both fields questions are being asked concerning the permanently threatened unity of the respective disciplines. There is no doubt very little in common between the “pure” experimental psychologist working on the memorization of meaningless syllables and the clinical psychologist who is trying to understand the dynamics of phobic behavior leading to a total inability to work. In a similar vein, apart from very general principles, there is very little common ground to be found between Jacques Lacan, Heinz Hartmann, Melanie Klein, Heinz Kohut, Wilfred Bion, and numerous others.

Can these gaps between and within each of these disciplines one day be reduced? Such an effort presupposes an analysis of the epistemological bases of each approach, and it seems doubtful that such an analysis would produce any unified theory.

ROGER PERRON

*See also:* Analytical psychology; *Année psychologique*, L’; Applied psychoanalysis and the interaction of psychoanalysis; Archives de psychologie, Les; “Claims of Psychoanalysis to Scientific Interest”; Claparède, Édouard; Cognitivism and psychoanalysis; Ego psychology; Janet, Pierre; Lagache, Daniel; Metapsychology; Meyerson, Ignace; National Psychological Association for Psychoanalysis; Piaget, Jean; “Project for a Scientific Psychology, A’”; Psychological types (analytical psychology); Self psychology.

### **Bibliography**

- Andersson, Ola. (1962). *Studies in the prehistory of psychoanalysis*. Stockholm: Svenska Bokförlaget.
- Assoun Paul-Laurent. (1981). *Introduction à l'épistémologie freudienne*. Paris: Payot.
- Couvreur, Catherine; Oppenheimer, Agnès, Perron, Roger, and Schaeffer, Jacqueline (Eds.). (1996). *Psychanalyse, neurosciences, cognitivisme*. Paris: Presses Universitaires de France.
- Perron, Roger. (1995). Prendre pour vrai. *Revue française de psychanalyse*, 59 (2), 499–512.
- Perron, Roger, and Perron-Borrelli, Michèle. (1997). *Fantasme, action, pensée*. Algiers: Éditions de la Société algérienne de psychologie.

### **Further Reading**

- Barron, James W., Eagle, Morris N., and Wolitzky, David L. (eds.). (1992). *Interface of psychoanalysis and psychology*. Washington, DC: American Psychological.

## **PSYCHOLOGY OF DEMENTIA PRÆCOX, THE**

*The Psychology of Dementia Præcox* dates from the period when Carl Gustav Jung was conducting clinical research at the Burghölzli university clinic in Zürich (1900–1909). Encouraged by Eugen Bleuler, he took an interest in *Dementia præcox* (schizophrenia) although he had distinguished himself for years

through his work using the association test and aimed at acquiring a better comprehension of psychodynamic processes in normal and hysterical subjects. It was first published in book form by Carl Marhold Publishers at Halle.

The work breaks down into five chapters. After a critical review of the existing literature on the subject, Jung starts out from Freudian psychology and his own research and establishes the concept of the complex, demonstrating its general influence on the psyche and the validity of associations. In chapter 4 the author describes the parallels between hysteria and *Dementia præcox*, their symptoms and their psychodynamic foundations. As an illustration he then provides a complete analysis of a case of paranoid dementia.

In both pathologies Jung discovers one or several complexes in the depths of the patient's being. In the case of hysteria these are linked to the symptoms in an obvious way and have never been completely overcome, while in the case of *Dementia præcox* they are fixed in a lasting fashion and the causal link with the symptoms cannot be determined. For Jung there was a powerful affect at the beginning of the disease. The author postulates the existence of a factor X, a metabolic toxin for example, that would create a directly harmful effect of the complex, or a predisposing factor, like a sort of organic cerebral disposition.

His most acerbic critics reproached Jung with trying to provide a psychological explanation for an affection with an undeniably organic cerebral origin in order to present an apology for Freud's ideas. But Jung never had any such intention. In any case, his work is perfectly consistent with the research at the Burghölzli asylum, which also helped Bleuler to situate patients' often-incomprehensible symptoms in a meaningful context of individual psychology. Bleuler paid his respects to Jung and to Freud in his important work on schizophrenia.

BERNARD MINDER

See also: Ego-libido/object-libido; Jung, Carl Gustav; Schizophrenia.

### Source Citation

Jung, Carl Gustav. (1907). *Über die psychologie der Dementia præcox: ein versuch*. Halle, Marhold; *Gesammelte werke*, vol. 3, Olten-Freiburg in Breisgau: Walter-Verlag, pp. 1–

316; The psychology of *Dementia præcox*. *Coll. works*, vol. 3, London: Routledge and Kegan Paul Ltd.

### Bibliography

Bleuler, Eugen. (1908). Dr Wilhelm Stekel, Spezialarzt für Psychotherapie in Wien: Nervöse Angstzustände und ihre Behandlung. *Münchener Medizinische Wochenschrift*, 32, 1702–1703.

———. (1911). *The group of schizophrenias* (Joseph Zinkin, Trans.) New York: International Universities Press.

Haenel, H. (1908). Literaturkritik. *Neurologisches Zentralblatt*, 1, 39–40.

### “PSYCHOLOGY OF THE UNCONSCIOUS, THE”

An article by Théodore Flournoy on the poems, reveries, and visions of an American student named Miss Miller inspired Jung to compare these products of the imagination with mythology and the history of religions. It was an opportunity for him to differentiate himself from Freud by laying the foundations for his theoretical constructions. Several powerful ideas were developed: the libido is not uniquely sexual; some unconscious content is a condensation of the collective history of psychic evolution; certain fantasies are recurrences of ancient beliefs—they cannot enable us to understand mythology but by finding the source of myths we can gain access to the psyche; and incest is first of all a psychic reality before it begins to concern the real mother. The article “The Psychology of the Unconscious” contains the seeds of all the Jungian concepts before he actually formulated them explicitly. It cost him his friendship with Freud and was followed by a long period of internal crisis.

In 1950 he reworked and updated the article in the light of his research over the intervening decades, though he did not deny any of its original contents. It was published under the title *Symbole der Wandlung* (Symbols of transformation).

In the first part Jung analyzes the religious sentiment and the difficulty of differentiating between human love and love of God or the divinity. By studying the interplay of the archetypes in the collective unconscious he reveals the psyche's capacity to rediscover in the present, and in relatively new forms, experiences and ideas that marked the history of humanity. The second part intro-

duces his concept of the libido, which he bases on his work on schizophrenia and which appears radically different from Freud's concept. Jung then goes on to describe his concept of incest, which is one of the pivotal points of his theory. Symbolically, incest signifies an ebbing of the libido (Jung speaks of regression) toward ancient layers of the unconscious located well beyond the genetic mother. For Jung the unconscious is a place of becoming, the locus of encounter with the "Great Mother." This return to origins is symbolized by the hero's combat with the monster. In his quest the hero aspires to being reborn but he must nonetheless renounce this incestuous attraction in order to be liberated from the maternal, otherwise he risks being engulfed by it. Jung thus develops the question of sacrifice. In the process of individuation, the organizing influence of the Self underlies this movement and actualizes itself through the Self's confrontation with ancient unconscious content.

VIVIANE THIBAUDIER

See also: Jung, Carl Gustav; Libido; Mythology and psychoanalysis; Projection and "participation mystique" (analytical psychology).

### Source Citation

Jung, Carl Gustav. (1911–1912). Wandlungen und Symbole der Libido. Beiträge zur Entwicklungsgeschichte des Denkens. *Jahrbuch für psychoanalytische und psychopathologische Forschungen*, III (1), 120–227; Psychology of the unconscious: A study of the transformations and symbolisms of the libido: A contribution to the history of the evolution of thought. *Coll. Works* (Vol. 5). London: Routledge & Kegan Paul.

### Bibliography

- Flournoy, Théodore. (1906). Miss Frank Miller, Quelques faits d'imagination créatrice subconsciente. *Archives de psychologie*, 5, 36–51.
- Freud, Sigmund, and Jung, Carl G. (1974a [1906–13]). *The Freud/Jung letters: The correspondence between Sigmund Freud and C. G. Jung* (William McGuire, Ed. Ralph Manheim and R.F.C. Hull, Trans.). Princeton, NJ: Princeton University Press.
- Guy-Gillet, Geneviève. (1984). Inceste et sacrifice. In *Cahier de L'Herne*, 46, Jung (pp. 64–80). Paris: Herne.
- Kacirek, Suzanne. (1980). Le concept de libido selon C. G. Jung: Des "Métamorphoses et symboles de la libido" à

"L'énergétique psychique." *Cahiers jungiens de psychanalyse*, 26, 1–20.

Shamdasani, Sonu. (1990). A woman called Frank. *Spring*, 50.

---

## PSYCHOLOGY OF WOMEN, THE. A PSYCHOANALYTIC INTERPRETATION

*The Psychology of Women. A Psychoanalytic Interpretation* consists of two volumes. The first, entitled "Childhood and Adolescence," appeared in 1944, followed in 1945 by the second, with the sub-heading "Motherhood." This breakdown corresponds to what Helene Deutsch called "the fundamental dualism of femininity," which opposes individual development and personality with the role of "servant of the species." She was trying to shed a psychoanalytic light on the conflicts that are born of this dualism, which is only surpassed and transcended through the reconciliation of the antagonistic goals of the individual and the species, a point Freud stressed in "On Narcissism: An Introduction" (1914c).

Published at the end of World War II, *The Psychology of Women* reviews and develops, in the light of new observations, the author's first conclusions concerning the different problems of female psychology described in her first book, *Psychoanalyse der weiblichen Sexualfunktionen* (Psychoanalysis of the sexual functions of women), published by the Vienna Verlag in 1925. This, together with her work on female homosexuality, was based on clinical material gathered over a twelve-year period. As her biographers have pointed out (Roazen), *The Psychology of Women* is also influenced by the author's personal experiences. The book was born of her double desire to put her ideas to the test of time, and to compare them with those of Freud.

Although certain concepts have aged, some of her theses are still pertinent: the "secondary" character of penis envy in girls; the slowness of the construction of femininity (the opposite position to that of Freud, who believed the fate of femininity was prematurely sealed at the phallic stage), which explains her decision to study the psychology of women only from the latency period onward; and the psychic importance of the phenomena of "expectancy" (linked to late anatomico-physiological

female maturation) and identifications. Deutsch described the development of the female personality as a process that takes place through a series of intermediary identifications that correlate with modifications affecting her objects and the links to them. Equally striking is her assertion that the rape fantasy is universal and non-pathological, being a veritable organizer of female sexuality.

There was no shortage of criticism for *The Psychology of Women*, either from the feminists, who reproached her for her Freudian orthodoxy, or from psychoanalysts, for the converse reason. Very few of those who welcomed Winnicott's ideas with enthusiasm were able to recognize similar ideas expressed in *The Psychology of Women*, particularly in volume 2, "Motherhood." Deutsch's great mistake is no doubt the fact that she named this vast psychoanalytic study of more than seven hundred pages *The Psychology of Women*.

JACQUELINE LANOUZIÈRE

*See also:* Deutsch-Rosenbach, Helene; Female sexuality; Femininity; Oedipus complex.

### Source Citation

Deutsch, Helene. (1944–1945). *The psychology of women. A psychoanalytic interpretation* (Vols. 1–2). New York: Greene and Stratton.

### Bibliography

Deutsch, Helene. (1991). *Psychoanalysis of the sexual functions of women* (P. Roazen, Ed., and Eric Mosbacher, Trans.). London: Karnac. (Original work published 1925)

Freud, Sigmund. (1914c). On narcissism: An introduction. *SE*, 14: 67–102.

Roazen, Paul. (1985). *Helene Deutsch. A psychoanalyst's life*. New York: Anchor.

### Further Reading

Schuker, Eleanor, and Levinson, Nadine. (1991). *Female psychology: An annotated psychoanalytic bibliography*. Hillsdale, NJ, and London: Analytic Press.

Tyson, Phyllis. (1996). Female psychology: An introduction. *Journal of the American Psychoanalytic Association*, 44(S), 11–22.

## PSYCHOPATHOLOGIE DE L'ÉCHEC (THE PSYCHOPATHOLOGY OF FAILURE)

Written between 1935 and 1939, the first draft of René Laforgue's manuscript *Psychopathologie de l'échec* (The psychopathology of failure) contained a chapter on Hitler, which the author is said to have destroyed because he felt threatened by the Gestapo. The first French edition of the book was published in Marseilles in 1941. In the same year, hoping to see his work translated into German, Laforgue appealed on several occasions to Matthias Göring, director of the Institute of Psychotherapy in Berlin. Having read the manuscript, a Professor von Hattenberg passed a negative judgment on the grounds that it "trots out Freud's doctrine in an utterly uncritical manner." In the last version, published after the author's death, the publisher acknowledged Mrs. Délia Laforgue, who had made changes and corrections in accordance with her husband's wishes and instructions.

Laforgue's book was a study of failure neurosis and the influence of what he called the "Super-I." "One day," he wrote, "we will find a better term for it, for example, 'Ductorium' as proposed by Edouard Pichon." By way of example, Laforgue took the Jewish "minority" (the word was replaced by "collectivity" beginning with the edition of 1944). The Jews, he argued, "harbor an obsessive fear of persecution which they frequently associate with an atmosphere, even should that atmosphere no longer justify the fear" (1941; the edition of February 1944 has: "an atmosphere which no longer justifies that fear"). The "Super-I" of the Jews ("Super-Ego" in the 1950 and 1963 editions) "collaborates in the persecution, and if need be provokes it... Its opposition determines ["may determine" in the editions of 1944 and 1953] in them a more or less pronounced infantilism and a more or less powerful latent homosexuality." According to Laforgue, that homosexuality was always reflected by a tendency to be a victim rather than a victor.

Laforgue also described collective and class-specific superegos, powerfully influenced by education and religion. Changing social class, specifically moving from the working-class to the bourgeoisie, produced individuals prone to failure on account of the unconscious influence exerted by a proletarian superego (comparable to the superego of ghetto Jews) reacting to the betrayal implied by upward social mobility.

In the second edition of Laforgue's book, famous patients and personalities like Rousseau and Robespierre, along with Napoleon, were scrutinized from a psychobiographical point of view. Chapter 12 of the first edition, "On Professional and Affective Orientation," in which he leaned heavily on the work of Professor Reiter, President of the German Health Institute, on the subject of the social value of an individual for the community, was removed from later editions and replaced by Laforgue's long study of Napoleon's failure neurosis.

Historians, like those who lived through the war years in France, have great respect for Laforgue's abilities as a clinician. But inasmuch as this some time member of International League against Anti-Semitism supported Marshal Petain, his psychoanalytical theories of collective psychology—and indeed his political judgment—should, to say the very least, be treated with great circumspection.

JEAN-PIERRE BOURGERON

See also: Failure neurosis; Laforgue, René.

### Source Citation

Laforgue, René. (1941). *Psychopathologie de l'échec*. Marseilles: Les Cahiers du Sud; (1944). 2nd edition. Paris: Payot; (1950). 3rd edition. Paris: Payot; (1963). 4th edition (Delia Laforgue, Rev.). Geneva: Éditions du Mont-Blanc.

### Bibliography

Mijolla, Alain de. (1988). Psychoanalysis and psychoanalysts in France between 1939 and 1945. *International Forum of Psychoanalysis*, 12, 136–156.

Roudinesco, Élisabeth. (1986). René Laforgue ou la collaboration manquée: Paris–Berlin 1939–1942. *Confrontation*.

---

## PSYCHOPATHOLOGY OF EVERYDAY LIFE, THE

Sigmund Freud's lively book, *The Psychopathology of Everyday Life*, has some unique characteristics. Freud discusses psychoanalytic matter in the context of everyday life, sidestepping the experience of neurosis. He abandons his customary process, that of discussing the normal in terms of the pathological. Everyday psychopathology is discussed with few allusions to infantile

sexuality and its impact on adult pathology. The theoretical aspect is practically nonexistent, although Freud does compare the interpretation of everyday life to dream theory, another banal psychopathological phenomenon familiar to everyone. He emphasizes the importance in life of displacement, condensation, over-determination, and the creation of compromise formations. He makes use of his knowledge and interest in literature to provide many examples by writers, poets, and dramatists, reinforcing his position by emphasizing their intuitive understanding of the meaning of parapraxis.

The book contains twelve chapters on forgetting (proper names, words belonging to foreign languages, series of words, impressions, and projects); childhood memories and screen memories; slips of the tongue (spoken and written); mistakes, clumsiness, symptomatic acts, errors, associations of several "parapraxes"; and the determinism of the unconscious, the belief in chance and superstition.

All these forms of behavior are grouped under the heading of "slips of the tongue": "I almost invariably discover a disturbing influence [in slips of the tongue] . . . which comes from something *outside* the intended utterance; and the disturbing element is either a single thought that has remained unconscious. . . . or it is a more general psychical motive force which is directed against the entire utterance" (p. 61). To belong to this category they must not exceed "the limits of the normal state" and they must "have been previously accomplished correctly."

Freud's description emphasizes various aspects of these phenomena: These are mental functions that "cannot be justified by an explanation of the representation of the goal toward which they are directed." This demonstrates the importance of the psychic determinism associated with unconscious desire and rejection. He notes, for example, the forgetting of a proper name, which is linked with a disturbance of a thought, due to an internal contradiction, arising from a repressed source (the name of the painter Signorelli replaced by the names Botticelli and Boltraffio). The use of free will assumes a distinction between conscious and unconscious motivation; accordingly, some motor acts are disturbed on account of the unconscious—for example, the loss or destruction of an object that has meaning either in terms of the person who has given it to us or because a symbolic association with something else has been shifted toward this

object. Our errors of judgment acquire a sense of certainty and remain convincing for us, precisely to the extent that they express a repressed content. This is, at the very least, the same reasoning used by the paranoid who rejects any accidental element in the psychic manifestations of other people, such as incorrect statements.

The meaning of symptomatic actions is sometimes difficult to determine; repressed ideas and tendencies remain hidden from the individual, as internal resistance presents an opposing force. Technically, slips of the tongue and bungled actions are made possible by the shifting of nervous excitation. In the example of the *lapsus linguae*, there can exist, between the intended word and the spoken word, a phonetic resemblance (a “contamination”) or psychological associations connected with the person’s history. As in dreams there is a disturbing element (which is repressed) that makes itself felt through “deformations, mixed formations, or compromise formations,” or, again as in dreams, a word may be replaced by its opposite. These phenomena reveal two factors simultaneously: a positive one (free association) and a negative one (relaxation of the inhibitory action of attention).

What mental factors are thus expressed? The disruptive idea arises from innate tendencies and should not be confused with the intentional idea, or an association exists between the two, or the disruptive idea is unconscious and comes into play when activity is undertaken, thus revealing itself by indirectly disturbing the intentional idea. This is the case with slips of the pen, where there can exist, in a waking state, a phenomenon of condensation, in which conscious and unconscious ideas overlap as in dreams. This is also the case when we forget past events that are associated with a memory likely to awaken a painful sensation from a different time (in keeping with the idea that the “unconscious is outside time”); or when we forget certain things because of a conflict associated with an opposing wish; or likewise when we make a mistake, or a strange impulse is manifested that contradicts an intended action. This is equally true of other kinds of acts, which are often symbolic representations of dreams or desires.

*The Psychopathology of Everyday Life*, one of Freud’s best known works, is an excellent introduction to psychoanalysis. His observation of the psychopathology of normal life has not, however, had the

subsequent theoretical development it deserves. Work on orality, anality, femininity, or sibling relations in everyday life would benefit from new investigations of metapsychology.

GISÈLE HARRUS-REVIDI

*See also:* Cryptomnesia; Déjà-vu; Delusion; Forgetting; Masochism; Negative hallucination; Parapraxis; Psychic causality; Slips of the tongue; Suicidal behavior; Time.

### Source Citation

Freud, Sigmund. (1901b). Zur Psychopathologie des Alltagslebens (über Vergessen, Versprechen, Vergreifen, Aberglaube und Irrtum. *Monatsschrift für Psychiatrie und Neurologie*, 10, 1–2, 1–32, 95–143; *Zur Psychopathologie des Alltagslebens*, Berlin: Karger, 1904; *GW*, 4; The psychopathology of everyday life. *SE*, 6.

## PSYCHOSES, CHRONIC AND DELUSIONAL

In psychiatry the term *psychosis*, first used to refer to mental illnesses in general, was later restricted to the major clinical forms: schizophrenia, chronic and delusional psychoses, and manic-depressive psychoses. Unlike the neurotic, the psychotic subject does not “criticize” the disorders of his or her thought. In 1845 Baron Ernst von Feuchtersleben used the term *psychosis* to refer to mental illness in his manual of medical psychology. At the end of the nineteenth century, alienists defined psychosis as the loss of reason and mental alienation.

Psychoanalysis seeks less to categorize mental illnesses than to identify their structures and mechanisms. A structural and dynamic definition of psychosis must be conceived on the basis of a primary disturbance of the libido’s relationship to reality, through splitting and the reconstruction of an alternative, delusional reality. Eugen Bleuler, influenced by psychoanalysis, characterized schizophrenia as a dissociation of thought through withdrawal into the self, or autism. He posited as its basis splitting, linked to a loosening of associative texture. Skirted around by Sigmund Freud, who preferred the term *paraphrenia*, the notion of schizophrenia nevertheless became standard within psychiatry and psychoanalysis. A second variety of chronic psychosis, paranoia, is characterized by systematic delusions (delusions of persecution, jealous delusions, erotomania, delusions of grandeur), the

predominance of interpretation, and the absence of intellectual deterioration.

In Manuscript H (1894), Freud designated three conditions as psychoses: hallucinatory confusion, paranoia, and hysterical psychosis (which he distinguished from hysterical neurosis). In his texts on the neuro-psychoses of defense (“The Neuro-Psychoses of Defence” [1894a] and “Further Remarks on the Neuro-Psychoses of Defence” [1896b]), he took the distinction between neurosis and psychosis as given. From his earliest writings, he undertook to characterize the psychopathology of the psychoses through his successive theories of the psychic apparatus. His only study of a case of psychosis is his commentary on Daniel Schreber’s *Memoirs of My Nervous Illness*. Freud’s correspondence with Carl Gustav Jung illustrates the development of Freudian doctrine between 1909 and 1911, and the essays “On Narcissism: An Introduction” (1914), “Fetishism” (1927), and “The Loss of Reality in Neurosis and Psychosis” (1924) show the further elaboration of his theories.

Freud examined the individual’s relationship to reality from the vantage point of a consideration of the libidinal cathexes. In the psychoses, the loss of reality—and the changed relationship to others following a radical decathexis of the objects of everyday reality (“the end of the world,” for Schreber)—must necessarily be considered in a way other than descriptive, taking into account the attempted reorganization of reality by the psychotic processes.

All psychoses are characterized by the coexistence of two attitudes: one that takes reality into account, and another that “this same ego, under the influence of the id, withdraws from a piece of reality” (1924e, p. 183). Delusions affirm the subject’s belief in the existence of an alternative reality that restores the primitive cathexes that archaically linked childhood awareness with an early love object. The reconstruction of reality in accordance with the “desires” of the id expresses both a defensive cancellation and a reparative force. This entails a process whose psychotic manifestation in no way excludes rearticulation in terms of the mechanisms defined by psychoanalysis. Thus, in Freud’s view, hallucinatory psychosis could be considered as the expression of an imaginary maintaining of an early reality whose loss the ego finds unbearable. This theorization requires the refinement of concepts such as regression, which is above all conceived as a function of development of the ego and of the libido:

In the one case, regression leads to primary narcissism, and in the other, to hallucinatory wish fulfillment.

Initially, Melanie Klein, like Karl Abraham, tended to base her clinical work on a psychopathological theory of the points of fixation and temporal regression of the libido. In addition to this temporal regression, Freud distinguished a topographical regression that made it possible to compare the mechanisms of dreams with those put into play in psychosis. “In schizophrenia, it is words that become the object of elaboration by the primary process; in the other, the dream, it is the thing-presentations: representations of things to which the words have led.” In schizophrenia, circulation is cut off between the preconscious cathexis of words and unconscious thing-presentations. The fundamental mechanism of paranoia is projection. The feeling of hatred toward the object is projected outward and then turned back onto the subject in the form of persecutory hatred.

In the final stage of his work, in describing the splitting of the ego, Freud was on the way to defining an original mechanism of the repudiation of reality in psychosis: denial of the reality of castration. This notion of the *Verleugnung* (denial) of castration, which he opposed to repression, goes back to the primal experience of loss. Thus, Jacques Lacan, taking up the term *Verwerfung* (rejection) in his discussion of the “Wolf Man,” translated the German *Verwerfung* as *foreclosure* and, on the basis of this notion of a primordial excision of a fundamental signifier, elaborated his conceptualization of psychosis. The phallus as the signifier of castration is not inscribed within the symbolic order. Not integrated into the psychotic’s unconscious, it returns to the real, especially in the phenomenon of hallucinations. Through Lacan’s paternal metaphor, it can be considered that foreclosure of the Name-of-the-Father is the hole in the symbolic that is inherent in all psychoses.

The psychoanalytic elaboration of a theory concerning chronic and delusional psychoses runs up against the difficulty and complexity of a concrete approach. It becomes diversified into a theoretical eclecticism bringing together the considerations through which each school of thought, and indeed each analyst, refines and consolidates the foundations of the transference relationship. For all the intrinsic interest of the original viewpoints of John N. Rosen, Frieda Fromm-Reichmann, Marguerite Sechehaye, Gisela Pankow, Gaetano Benedetti, or Piera Aulagnier, among others, it is

impossible to recognize their particular relevance without having access to the specific techniques used in their respective therapeutic approaches.

Through a “psychotic transference” that moves from extreme avoidance to a relationship that is almost one of merging, demands are placed on the analyst that touch his or her own archaic unconscious dispositions; “falling in love-hate” and the preponderance of narcissistic investment over object investment make it difficult to manage. What place does this relationship have within the complexity of medication-based, institutional, or readaptive approaches? Analytic theory must certainly be remembered in a variegated context (families, caregivers, recipients of care) if one wants to maintain a certain structural coherence. José Bleger’s notion of *framework*, Lacan’s of *historization*, and the understanding of transference and counter-transference—both individual and institutional—must always be implemented when the challenge of treating the psychoses is undertaken.

MICHEL DEMANGEAT

*See also:* Ego Psychology and Psychosis; Foreclosure; Historical truth; Hypochondria; Indications and contraindications for psychoanalysis for an adult; Infantile psychosis; Mathilde, case of; Paranoia; Paranoid psychosis; Paraphrenia; Persecution; Psychotic/neurotic; Schreber, Daniel Paul; Symbolization, process of.

### **Bibliography**

- Freud, Sigmund. (1894a). The neuro-psychoses of defence. *SE*, 3: 41–61.
- . (1896b). Further remarks on the neuro-psychoses of defence. *SE*, 3: 157–185.
- . (1911c [1910]). Psycho-analytic notes on an autobiographical account of a case of paranoia (dementia paranoides). *SE*, 12: 1–82.
- . (1914c). On narcissism: An introduction. *SE*, 14: 67–102.
- . (1924e). The loss of reality in neurosis and psychosis. *SE*, 19: 180–187.
- . (1927e). Fetishism. *SE*, 21: 147–157.
- . (1974a [1906–13]). *The Freud/Jung letters: The correspondence between Sigmund Freud and C. G. Jung* (William, McGuire, Ed; Ralph Manheim and R. F. C. Hull, Trans.). Princeton, NJ: Princeton University Press.
- Lacan, Jacques. (1966). On a question preliminary to any possible treatment of psychosis. In *Écrits: A Selection*

(Alan Sheridan, Trans.). New York and London: W. W. Norton.

## **PSYCHOSEXUAL DEVELOPMENT**

Psychosexual development is the progressive evolution of infantile sexuality as it passes through the different stages or phases of psychic organization (oral, anal, phallic) with due regard for a prevalent erogenous zone, which organizes fantasies, and a certain type of object relation. Complete psychosexual organization is not reached until the arrival of puberty and a final phase of libidinal development, the genital phase.

Freud saw infantile sexuality as being active from the beginning of life. This broadened the notion of sexuality, giving it a range of extension that is specific to psychoanalysis.

In the *Three Essays on the Theory of Sexuality* (1905d), Freud initially saw infantile sexuality as a sort of precursor of adult sexual perversions and a blueprint for pubertal genitality, but he later described it as the mainspring of psychic development. He used the term *infantile sexuality* in an effort to acknowledge the existence of the stimuli and the needs for satisfaction that involve specific body zones (erogenous zones) that seek pleasure independently of exercising a biological function. He therefore described the sexual instinct as becoming separate from the vital functions that ensure the preservation of the organism in accordance with the anaclitic model (whereby the sexual instincts initially depend on those vital functions). The pleasure bonus provided alongside the accomplishment of the function would, in a second stage, be sought for its own sake. Freud thus considered anaclysis, the erogenous zone, and autoeroticism to be three intimately linked criteria for the definition of infantile sexuality.

The Freudian scheme of the phases of libidinal development links two essential components at each stage: on the one hand, an organizing erogenous zone, along with the excitations and instinctual movements for which it is both the link and the source, and on the other, the modalities of the object relation linked to development of the ego.

In the *Three Essays*, Freud stressed the existence and importance of oral and anal erogenous zones (in addition to the genital which is the primary erogenous zone in adults), describing them as pregenital and



highlighting the autoeroticism that is linked to them: sucking in relation to oral activity, retention/expulsion for anal erotism.

The specification of infantile genital organization as phallic organization nevertheless shows clearly that the prevalence of one erogenous zone is inseparable from a certain mode of symbolic organization. The Oedipus complex is organized around the idea of castration, which is represented in the unconscious as castration of the penis (Perron and Perron-Borelli, 1996). The loss of the breast and feces that are specific to the oral and anal stages can also be considered as early symbolic forms of genital castration.

The relationship between weaning—as implementing the absence of the mother—and the Oedipus complex introduces the structural point of view, which relativizes the developmental model of the stages and gives it its best perspective (Brusset, 1992).

In the normal evolution of sexuality the component instincts of childhood are progressively integrated into the genital sexuality of the adult. What remains of them is found in the foreplay that precedes the sexual act proper.

The potential for stimulation of these pregenital erogenous zones remains present in the body and in the mind and they tend to be reactivated on the occasion of later sexual experiences. Their degree of erotism is integrated into the genital sexuality of the adult. Excessive repression of these residues from the infantile period can lead to neurotic symptoms. Similarly, what persists in a prevalent and manifest manner in the perversions is repressed in neurosis. Hence Freud's famous aphorism: "Neurosis is the negative of perversion."

The phases Freud described between 1905 and 1923 correspond to successive organizations of the sexual instinct under the primacy of a given erogenous zone: the oral phase, sadistic anal phase, infantile genital or phallic phase, followed by the genital phase after puberty. He also distinguished at the same time the different stages leading from autoerotism to full object love, that is, the progression from autoerotism, narcissism, toward the homosexual or heterosexual object choice.

Three points deserve to be raised here in order to provide a better definition of the notion of psychosexuality as envisaged by Freud.

1) The body is first and foremost considered as the seat of the instincts (drives) and the source of the exci-

tations aiming for satisfaction. In the *Three Essays* he makes a point of defining infantile sexuality as a criterion for organ pleasure and autoerotic satisfaction. However, in the course of the following years he integrated his earlier discoveries about the role of fantasies into this. He showed, specifically, how the fantasy works "by integrating the attachments of infantile sexuality can, depending on the case, result in conscious formations (daydreaming, for example) or, on the contrary, formations that are repressed into the unconscious" (Perron and Perron-Borelli, 1996).

2) It should be noted that these infantile manifestations of sexuality only come to play their full role "après coup." The adult pervert's exclusive fixation on certain components of infantile sexuality must be understood as a regression and a return to pregenital fixations.

3) Finally, infantile sexuality culminates toward the fourth or fifth year of life, the age when sexual tumult gradually enters a latency period, and is not reactivated until puberty when it leads to adult sexuality in the context of general maturity. There is therefore at this stage a halt, a decline in psychosexuality, and this period is then subjected to the infantile amnesia of the latency period. Freud related this diphasic establishment of sexual life, which can be observed only in human beings, to events in humanity's prehistory.

In any case, it is during the period of latency "that are built up the mental forces which are later to impede the course of the sexual instinct and, like dams, restrict its flow" (1905d, p. 177).

After the *Three Essays*, Freud gave the oedipal conflict its full organizational value, normal libidinal development being defined in psychoanalytic theory as the integration of the polymorphously perverse aspects of infantile sexuality under the primacy of the genital organization.

Following the *Three Essays*, Freud's successive contributions (1913–24) continued to expand on the general outline of the stages of libidinal development.

Karl Abraham tried to find the etiopathogenic basis for all of psychopathology in this model. He distinguished two stages within each of the first two phases (oral and sadistic oral, anal and sadistic anal) and he further stressed the link existing between the specific erogenous zone and the modalities of object relation particular to it.

Many authors after him, such as the proponents of Ego-Psychology (Heinz Hartmann, Ernst Kris, and Rudolph Loewenstein), used the outline of libidinal development and made it a major element in a genetic psychology that could be integrated into a general psychology. Others, on the contrary, particularly in France (Jean Laplanche and Jean-Bertrand Pontalis; Brusset, 1992; Perron, Perron-Borelli, 1996) insisted on the importance of the notion of organization. Each stage or phase of development creates a structure, in the modern sense of a self-regulated functional system tending toward equilibrium. Each of these phases in psychosexual development organizes not only the present state of mental functioning but also its future state. Infantile genital organization therefore defines the oedipal phase as the great organizer of mental functioning, laying down in the infantile phase of sexuality what will become the genital organization of the adult.

JEAN-FRANÇOIS RABAIN

*See also:* Libidinal development.

### **Bibliography**

- Brusset, Bernard (1992). *Le Développement libidinal*. Paris: Presses Universitaires de France.
- Freud, Sigmund (1905d). Three essays on the theory of sexuality. *SE*, 7: 123–243.
- Mijolla, Alain de, and Mijolla-Mellor, Sophie de (Eds.). (1995). *Psychanalyse*. Paris: Presses Universitaires de France.
- Perron, Roger, and Perron-Borelli, Michele. (1996). *Le Complexe d'Édipe* (2nd edition). Paris: Presses Universitaires de France.

### **Further Reading**

- Davison, Susan, rep. (1998). Panel: A contemporary review of the psychosexual phases of development. *International Journal of Psychoanalysis*, 79, 164–167.
- Lester, Eva P. (1976). On the psychosexual development of the female child. *Journal of the American Academy of Psychoanalysis*, 4, 515–528.
- Siskind, Diana. (1994). Arrests of psychosexual development and separation-individuation. *Psychoanalytical Inquiry*, 14, 58–82.

## **PSYCHOSOMATIC**

It is difficult to provide an exact definition of *psychosomatics*. To some extent the term itself already indicates a theoretical bias. It joins together the normal or pathological dynamics of both mental and somatic structures and assumes their close interaction. According to Pierre Marty, psychosomatics is the clinical observation of individual mental or somatic organization, disorganization, and reorganization, the attempt to draw from those observations theoretical findings, and the practical application of those findings to the therapeutic situation. If considerably broadened, *psychosomatics* would involve a global understanding of what it is to be human.

The term *psychosomatics* appeared in 1818 in the work of J. C. H. Heinroth, a German psychiatrist, and reflects a naturalist and vitalist approach to medicine. The context was formalized in 1945 by British psychologist James L. Halliday. The word has been in use since then among a wide range of practitioners, often with different interests. In the United States it is often referred to as psychosomatic medicine.

Prior to these developments, the interaction of *psyché* and *soma*, both within and beyond the context of philosophy and religion, reflected a vague association of the term with organic disease. It has been said (Kamieniecki) that “the history of medicine has written the prehistory of psychosomatics.” This prehistory has gradually distinguished psychosomatic medicine, in various socio-cultural contexts, from its philosophical, mystical, and religious corollaries, the *Corpus Hippocraticum* being a good example. Since then there has been a continued effort to identify the links between “the ontological unity of being and the phenomenological duality of its operation.”

This project, which has become for some researchers an original and fundamental discipline, can be considered part of a psychoanalytic framework, for it “consists in subjecting the somatic to the same dynamic and the energetic considerations that govern the life of individuals undergoing analysis,” according to the authors of *L'investigation psychosomatique* (Psychosomatic investigations; Marty, M'Uzan, and David). It must be noted that this project has generated no consensus, since it is a matter of applying these principles to the field of organic disease from the standpoint of psychoanalysis, a concept that has its detractors. Psychosomatics relates to the human indi-

vidual in its concrete being, living and sexual, acting through its own body and mental organization—including the conflict within the individual movements between life and death (Marty)—and where illness is an incarnation of the logic governing the living being.

In the area of organic disease, where research in psychosomatics has been directed, what has been referred to as the “psychosomatic phenomenon,” the interaction of psyché and soma, remains problematic and has led to numerous claims that have further confused the concept: psychogenesis, generalized conversion, somatization, and so on, not all of which have the same heuristic value. Somatization, seen as the result of a process in which mental causality (in the broad sense) plays a role, has become a doctrine for some. However, the real problem and focus of interest for the psychosomatic psychoanalyst, aside from any reactive mental disturbances, remains the discovery of a process for understanding and interpreting the reality of the disease, any possible exacerbation, and its resurgence in times of crisis. This entails the question of causal factors, while at the same time giving medical factors their due. It therefore includes the notion of a possible psychic causality that would interweave two histories of pathological alteration that belong to different orders but whose interactions are not purely random. When the two fields do not interact, there is no psychosomatic phenomenon, only the evolution of somatic morbidity along biological lines. The possible psychic causes remain an open question; these may be neither necessary nor sufficient but cannot be overlooked, even if we do not believe in psychogenesis or a limited determinism, and even if we feel that the “constructed meaning” of a symptom is not the cause or the origin of the disturbance.

Freud was not overly concerned with a strictly psychosomatic approach to disease, but in 1923 he wrote, “According to the indications of some analysts, the psychoanalytic treatment of obvious organic disturbances is not without a future, since it is not unusual for a psychic factor to play a role in the genesis and persistence of these affections” (1923a [1922]). The libidinal organization points to the somatic as a source; the description of actual neurosis and its underlying hypotheses (for some this is related to the so-called process of somatization); the idea of libidinal stasis identified in the organic disease; and the emergence of the id (the term originates with Groddeck, a

precursor of psychosomatics according to some authors)—all these theoretical hypotheses, after being reworked, have led to the conclusion that Freud was also a pioneer in this field.

More recent interest in psychosomatics can be traced to the investigations of the American researchers Helen Flanders Dunbar and especially Franz Alexander during the 1940s. Their work helped develop later research and elements of it can be found, in modified form, among psychosomaticians and clinical psychologists. The so-called New York School (Dunbar) was associated with the culturalist movement of the time. They related organic pathology to pre-morbid “personality profiles,” specific to certain clinical symptoms: the structure of the personality would expose a specific part of the organism to external aggression and would prepare the way for somatization. Dunbar also hypothesized an emotional dynamic, derived from Darwin, who assigned a defensive goal to the emotions, coupled with the affective repercussions within the body itself. Dunbar was one of the first to take a neovitalist approach—the degradation of vital energy—to developing an understanding of psychosomatics. For him, the exclusion of conflict outside consciousness would result from a short-circuiting of the mental (though he does not use this word), through subcortical mechanisms. This school of thinking concluded that psychoanalysis alone would provide a deeper understanding of the processes in question.

Franz Alexander believed that the personality profile alone was not sufficient to determine causality. He centered his hypotheses on the notion of a “specific psychodynamic constellation.” This constellation was based on basic reactions that ensued following an increase in tension within the psychic apparatus, reactions that encompassed the autonomic nervous system and the subcortical stem, along with basic dispositional characteristics. The idea of psychosomatic medicine (the title of his first book) was both established and subject to criticism because of its over-reliance on biology. But internal conflicts and emotional reactions culminating in physical changes also played a role. This sequence led to the concept of “organ neurosis,” corresponding to the abnormal stagnation of a quantity of energy in an organ or system. These connections between affective states and somatic behaviors resulted in “psychosomatic patterns” that, from functional disturbances, could produce organic symptoms. One finds in his work profound intuitions that have con-

tributed to contemporary theory in spite of his overly biological approach and pertinent suspicion about the concept of organodynamics, a concept picked up by Henri Ey.

During the 1960s, two approaches to psychosomatics appeared in France. These were the sources of a number of subsequent developments that altered, weakened, and expanded certain hypotheses, and modified the clinical and therapeutic approach to the field. Jean-Paul Valabrega promoted an approach to somatic symptoms through a model of generalized conversion isolation, whose rediscovered source in fantasy would give meaning to the symptom. For Valabrega the isolation of the conversion phenomenon from its source and its specifically hysterical environment resulted in the development of manifestly visceral symbolizations, which originated in conversion phenomena and were unexplained by reference to a hysterical kernel common to all neuroses. In this context of “psychosomatic conversion,” Valabrega insisted on the resurgence of the fantasy at the very site from which it had been expelled, a hypothesis associated with the general problem of the accessibility of the symptom to symbolization and meaning. The psychosomatic symptom was said to constitute a physical barrier that had to be crossed by separating it from its hidden fantasy elements, which had been kept in check. “In other words, according to the hierarchical etiology, the specificity is defined less by physiopathological or psychopathological mechanisms than by the singular mode of organization which underlies both mechanisms” (1966/1974).

In 1963, the so-called psychosomatic school of Paris (Pierre Marty, Michel de M'Uzan, Christian David, Michel Fain) formalized its approach, based on the notion of deficit, where a mental loss (fantasy, oneiric, associative, the loss of mental defenses) was seen as paradigmatic. This concept meshed satisfactorily with the findings of psychoanalysis, especially in the area of psychic economy, where the somatic symptom is asymbolic and does not produce meaning. Their approach gave rise to a number of developments. After Pierre Marty introduced the concept of *operative thought*, other clinical concepts emerged, such as *essential depression* and *chronic disorganization*, and Marty insisted on the reorganizing value of the regression/fixation system. The process of disorganization, triggered by trauma and incapable of stopping the regression/fixation system, became the crux of the “somatization process.” However, regression can also be pathogenic and reversible

illnesses are conceivable, in terms of points where disorganization is halted at various stages of somatic fixation. This model, based on monist, evolutionist, and neovitalist principles, and extensively described in Marty's writings, presents an internal coherence that has made it a classic, although not always accepted, reference in the field.

ALAIN FINE

*See also:* Actual neurosis/defense neurosis; Alexander, Franz Gabriel; Groddeck, Georg Walther; Marty, Pierre; Psychogenesis/organogenesis; Psychosomatic limit/boundary; Somatic compliance.

### **Bibliography**

- Alexander, Franz. (1950). *Psychosomatic medicine, its principles and applications*. New York: Norton.
- Kamieniecki, Hannah. (1994). *Histoire de la psychosomatique*. Paris: Presses Universitaires de France.
- Marty, Pierre. (1990). *La psychosomatique de l'adulte*. Paris: Presses Universitaires de France.
- Marty, Pierre, M'Uzan, Michel de, and David, Christian. (1963). *L'Investigation psychosomatique*. Paris: Presses Universitaires de France.
- Valabrega, Jean-Paul. (1974). Problèmes de théorie psychosomatique. In *Encyclopédie médico-chirurgicale: Psychiatrie*. Paris: E.M.-C. (Original work published 1966)

### **Further Reading**

- Winnicott, Donald W. (1966). Psycho-somatic illness in its positive and negative aspects. *International Journal of Psychoanalysis*, 47, 510–516.

---

## **PSYCHOSOMATIC LIMIT/BOUNDARY**

The term *psychosomatic limit* (or *psychosomatic boundary*) designates the virtual demarcations and separations between the space of the body and that of the psyche. At the same time this boundary serves as a contact barrier where, if the person has good mentalization, psychic phenomenon take on symbolic or metaphorical significance at the somatic level or, conversely, somatic excitation is registered in the psyche.

This concept cannot be grounded in a monistic account of the *psyche-soma* (Pierre Marty, the Paris

School), but should rather be understood as André Green explained in *Somatization, psychanalyse et science du vivant* (Somatization, psychoanalysis, and the science of the living; 1994), in terms of a “structural dualism that comes out of a de facto monism . . . in which the psychic apparatus is posited as being rooted in the nervous system but as developing its own distinct properties from there, which data based on biological structures alone cannot account for.” The concept of the psychosomatic limit is present but seldom explicit in the work of Sigmund Freud. The notions of the drives, conversion, and the ego bring this concept into play. One of its synonyms, the word *frontier*, appeared for the first time in *Three Essays on the Theory of Sexuality* (1905d) in connection with the instincts; there Freud described an instinct as “the psychical representative of an endosomatic, continuously flowing source of stimulation. . . . The concept of the instinct is thus one of those lying on the frontier between the mental and the physical” (p. 168). Instinct, representing a source of internal excitations, thus becomes one of the forms of the body’s language. In “Instincts and Their Vicissitudes” (1915c), Freud again used the word *frontier* to convey the idea of a limit or boundary: “An ‘instinct’ appears to us as a concept on the frontier between the mental and the somatic . . . as a measure of the demand made upon the mind for work in consequence of its connection with the body” (pp. 121–122). The psyche works only because of its link with the corporeal, because without this virtual contact barrier, the psyche would be nothing and the body would be only an object.

In *Studies on Hysteria* (1895d), Freud dealt particularly with conversion, but that concept was defined for the first time in “The Neuro-Psychoses of Defence” (1894a): “In hysteria, the incompatible idea is rendered innocuous by its *sum of excitation* being transformed into something somatic. For this I should like to propose the name *conversion*” (p. 49). The psychosomatic limit is crossed and there is the mysterious “leap from the psychical into the somatic” that conversion involves owing to “motor innervation” (p. 49).

The ego, as described in the second theory of the psychic apparatus (1923d [1922]), is above all a bodily ego; it is not only a surface being, but it is itself the projection of a surface. It represents the surface of the mental apparatus. If the ego is a surface with both psy-

chic and somatic limits, it can be ruptured, as when physical pain results in a heightened narcissistic cathexis of the body that empties the ego and leads it to defend and reconstitute itself.

Notions related to the psychosomatic boundary can be found. For example, there are the “transitional phenomena” described by Donald Winnicott (1971), an internal space and external reality where body and language, which together support this space, establish an intersection between psyche and soma. Babies experience burps and anal noises. “It can be supposed,” Winnicott writes, “that thinking or fantasies acquire a link with these functional experiences.” In his definition of *holding* (1965), Winnicott linked tonus (the physical holding of the body) to processes that may appear to be physiological but that in fact originate in the infant’s psychology.

The concept of the psychosomatic limit, though not fully developed in Freud’s writings, nevertheless turns up there in an essential way. In his 1994 book, Green described the concept as implicitly present whenever the body expresses itself directly within the framework of the psyche: in functional signs, conversion, actual neuroses, and psychosomatic pathology.

GISÈLE HARRUS-REVIDI

See also: Body image; Ego; Drive/instinct; Holding.

### Bibliography

- Freud, Sigmund. (1894a). The neuro-psychoses of defence. *SE*, 3: 41–61.
- . (1905d). Three essays on the theory of sexuality. *SE*, 7: 123–243.
- . (1915c). Instincts and their vicissitudes. *SE*, 14: 109–140.
- . (1923d [1922]). A seventeenth-century demonological neurosis. *SE*, 19: 67–105.
- Freud Sigmund, and Breuer, Josef. (1895d). Studies on hysteria. *SE*, 2: 48–106.
- Green, André. (1994). *Somatization, psychanalyse et science du vivant*. Paris: Eschel.
- Winnicott, Donald W. (1965). The theory of infant-parent relationship. In his *The maturational processes and the facilitating environment*. London: Hogarth.
- . (1971). *Playing and reality*. London: Tavistock.

## **PSYCHOTERAPIA (PSIXOTERAPIJA-OBROZRENIE VOPROSOV LECENIJA I PRIKLADNOJ PSIXOLOGII)**

In Moscow in 1909 the military physician Nikolai A. Vyroubov founded the review *Psychoterapia, A Review of Questions of Therapy and Applied Psychology* with a view to introducing Russian practitioners to western schools of psychotherapy.

The thirty issues of the review (which appeared from January 1910 to the end of 1917) focused increasingly on psychoanalytic theories but they also presented the work of Freud's great rivals, like Paul Dubois and Johannes Marcinowski. Readers were also informed of the split brought about by Alfred Adler (1911). The review enjoyed the support of the very influential Moscow Psychiatric Circle and the eminent psychiatrist Vladimir P. Serbski (1858–1917), who had decided to dissociate himself from the nosological and purely organicist orientation of Kraepelin's school.

Completing the work of the "Library of Psychology and Psychoanalysis," also organized by Vyroubov and which published Freud's major works, *Psychoterapia* translated no fewer than twelve of Freud's short technical texts. It also introduced its readers to the works of Adler, Ferenczi, Jung, Rank, Reik, Sachs, and Stekel. The orthodox tendency of the review, directed by doctors Nikolai Ossipov and Mosche Wulff, gave an account of the first Russian attempts to apply the method of free association to clinical neurosis. But it also published works of psychoanalysis applied to subjects as diverse as political jousting, stage fright in actors, and folklore. Supporters of the breakaway Adlerian school, being more politicized, criticized the "monoetiology" (sexual) of the neuroses.

Just before it disappeared, the review had begun to manifest great openness to the medical and scientific culture or the West, and also to its literary and artistic culture. There was no other Russian review of psychoanalysis until 1991—not even during the short and amazing period of Bolshevik psychoanalysis (1920–1930). As a mouthpiece for democratic and liberal ideals, *Psychoterapia* was of capital importance for the peaceful acceptance of psychoanalysis in Czarist Russia.

ALEXANDRE MIKHAEVITCH

See also: Russia/USSR.

## **Bibliography**

Maximov, Valeri. (1988). Histoire de la psychanalyse: La psychanalyse russe. *L'Âne*, 10, 3–5.

Mikhalevitch, Alexandre. (1991). L'âge d'argent de la psychanalyse russe. Les premières traductions des œuvres de Freud en Russie prérévolutionnaire, 1904–1914. *Revue internationale d'histoire de la psychanalyse*, 4, 399–406.

## **PSYCHOTHERAPY**

Psychotherapy is a method for the treatment of psychological problems, which are often expressed somatically.

Therapies can be classified following various models. In the cathartic model, the patient is urged to speak, in order to expel or get rid of his suffering. The therapist favors the act of communication over the content of what is expressed. In the reparative model, the therapist tries to help the patient by bringing love and understanding to cancel out the prejudice he has been victim of or to make up for some internal deficit. With the educational model, the therapist guides the patient in the "right" direction, advising him as to his life choices. He "corrects" the mistakes of nature, parental education, or social environment.

Freud demarcated himself dramatically from hypnosis and cathartic post-traumatic abreaction in developing an original psychotherapeutic dimension, centered on the exploration of the unconscious, the study of psychic functioning and intrapsychic conflicts, and transference-counter-transference relation (Ellenberger, 1970). He emphasized psychic reality understood through the reality of narrative. Accordingly, the psychotherapy to be discussed here is psychoanalytic psychotherapy, situated within the context of the theory, technique, and framework of psychoanalysis.

The term *psychotherapy* surfaced for the first time in 1872, while the term *psychoanalysis* came to be known only in 1896. But it wasn't until 1905, in his article "On Psychotherapy" (1905a [1904]) that Freud clearly distanced himself from hypnosis by opposing the cathartic method to the analytic method. For a number of decades, he had used the terms *psychoanalysis* and *psychotherapy* interchangeably, but shortly before 1920 he abandoned the term *psychotherapy* definitively, qualifying his method from then on as *psychoanalysis*. This abandonment occurred after the defections of Alfred Adler, Wilhelm Stekel, and Carl G.

Jung and, in a second stage, his differences with Otto Rank and Sándor Ferenczi. In effect, some of those in Freud's circle were advocating a more active attitude on the part of the psychoanalyst to accelerate the psychoanalytic process as well as to shorten its duration. A reaction was not long in coming: Ernest Jones and Edward Glover emphatically denounced any deviation from a traditional treatment, and any psychotherapeutic approach, such as a return to pure suggestion of the preanalytic period (Robert Wallerstein). This traditional position was the "official" one of the psychoanalytic movement for a very long time. Nevertheless, in the 1950s the term *psychoanalytic psychotherapy* gained currency among psychoanalysts themselves, who came to believe that certain changes had to be made in the framework of the classical psychoanalytic model, which was not appropriate for the psychopathology of some patients.

As of 2005, questions about the differences between psychoanalytic psychotherapy and psychoanalysis are still posed in terms of process: how, for example, could the psychoanalytical process be influenced by reworking the framework? The face-to-face position implies seeing the analyst, being able to observe his gestures and unconscious corporal reactions, to hang onto his every word and look into his eyes. Likewise, not being seen by the analyst can result in the patient's feeling lost, cast into the abyss, or on the contrary allow him to feel emotions that would be blocked by a face-to-face expression. However, these differences in formal framework (frequency of sessions, face-to-face or couch-armchair, more or less active position of the psychoanalyst, etc.) are insufficient, in themselves, to characterize the type of process underway. In any event, according to René Roussillon (1986), a psychoanalytic approach can only explore certain portions of the psyche. Even where the choice of the framework (psychotherapy or psychoanalysis) favors a psychoanalytical approach, this is not always necessarily the same one. Finally, the psychotherapeutic process is characterized by a transference of partial objects to the psychoanalyst while, in the psychoanalytical process, these partial transferences would be worked through until there was a full development of the transference neurosis.

Other authors have brought out differences in therapeutic aims. Ideally, in psychoanalysis the framework should allow exploration of the patient's unconscious with the psychoanalyst following the patient as far as

he is able to go. According to this very strict definition, psychoanalysis does not, a priori, aim at a therapeutic goal. Instead, the therapeutic result emerges from the psychoanalytic process. By contrast, psychotherapy does imply a goal: to diminish the suffering of the patient, allowing him to return to work, and so on. However, these differences are not always so clear-cut in the reality of practice among psychoanalysts and psychotherapists. Whatever technique is chosen, standard treatment or face-to-face, the psychoanalyst has a "psychoanalytic function," so that any psychotherapeutic approach undertaken by the psychoanalyst involves psychoanalytical work.

Psychotherapy cannot be isolated from its social context. After the Second World War, the development of social health care programs allowed compensation for psychiatric care and the establishment of a variety of facilities for the treatment of specific pathologies. Many of the professionals practicing in these institutional settings were trained in psychoanalytic psychotherapy by psychoanalysts working in the field, or else were educated in teaching institutes that structured their curricula in accordance with psychoanalytic psychotherapy. These professionals engaged in personal psychoanalytic work without, necessarily, matriculating in the training courses of psychoanalytic societies; but very often a veritable analytical process developed with patients that they were treating in their institutions.

Accordingly, the wish of Freud (1919a [1918]) has been fulfilled, "to alloy the pure gold of analysis freely with the copper of direct suggestion" (p. 168) to create "a psychotherapy for the people" (p. 168), and to alleviate a greater portion of "the vast amount of neurotic misery which there is in the world" (p. 166), which the small number of psychoanalysts cannot greatly affect. Clearly Freud wanted to see the traditional treatment adapted to treat a greater number of patients as soon as "the conscience of society will awake" (p. 167). The concern to preserve psychoanalytic thought in some institutional form has led national societies of psychoanalytic therapy to create organizations like the European Federation for Psychoanalytic Psychotherapy (EFPP).

Psychoanalysis and psychoanalytic psychotherapy, and their particular adaptations (child psychoanalysis, group psychoanalysis, analytical psychodrama, psychoanalytical couple or family therapy, etc.) constitute a

“psychoanalytic field,” very different in nature from therapeutic techniques. The latter, basically anti-analytic, may be considered as “an ensemble of ready-made counter-transference approaches meant to function as institutional defenses, as a system of alleviating anxieties prompted by the relation to the other,” representing “group-oriented ideologies” (Roussillon, 1986).

The psychoanalytical approach often requires much time since it favors the process rather than the suppression of symptoms, which is the case with non-analytical therapeutic techniques. In the interest of budgetary considerations, social agencies that reimburse psychic treatment try to limit its duration or the amount of compensated sessions, or else to favor approaches that aim to eliminate symptoms very quickly, without taking account of their function in the overall psychic economy of the patient. The psychoanalytical approach runs the risk of losing its liberty and revolutionary quality in submitting overly to social constraints. Countries that seek to integrate the psychoanalytic approach in the master plan of their treatment policies risk making it shed its special and irreverent identity, becoming increasingly therapeutic, in the sense of “suppressing symptoms” (Frisch, 1998). The notion of *conflict*, central in psychoanalysis, has consequently been introduced in the psychoanalytic movement on issues relating to its future and its identity: it must either evolve toward isolation to maintain its purity (psychoanalysis), or adapt to social constraints to survive (psychoanalytical psychotherapy), but at the risk of losing its soul.

SERGE FRISCH

*See also:* Analyzability; Cathartic method; Deutsches Institut für Psychologische Forschung und Psychotherapie (Institut Göring); Directed daydream (R. Desoille); Face-to-face situation; Group psychotherapies; Hypnosis; Initial interview(s); “Lines of Advance in Psycho-Analytic Therapy”; Narco-analysis; Psychodrama; Psychoanalytic family therapy; Relaxation psychotherapy; Suggestion; Symbolic realization.

### Bibliography

- Ellenberger, Henri F. (1970). *The discovery of the unconscious. The history and evolution of dynamic psychiatry*. New York: Basic Books.
- Freud, Sigmund. (1919a [1918]). Lines of advance in psycho-analytic therapy. *SE*, 17: 157–168.

Roussillon, René. (1986). Préface, in M. Berger (Ed.), *Entretiens familiaux et champ transitionnel*. Paris: Presses Universitaires de France.

Wallerstein, Robert S. (1995). *The talking cures*. New Haven, CT, and London: Yale University Press.

### Further Reading

- Bergman, Anni. (2002). Changing psychoanalytic psychotherapy into psychoanalysis. *International Journal of Psychoanalysis*, 83, 245–248.
- Kernberg, Otto. (1999). Psychoanalysis, psychoanalytic psychotherapy and supportive psychotherapy. *International Journal of Psychoanalysis*, 80, 1075–1092.
- Stone, Leo. (1954). The widening scope of indications for psychoanalysis. *Journal of the American Psychoanalytic Association*, 2, 567–594.
- Wallerstein, Robert S. (1989). Psychoanalysis and psychotherapy: An historical perspective. *International Journal of Psychoanalysis*, 70, 563–592.

---

## PSYCHOTIC DEFENSES

Psychotic defenses are psychic processes involving unconscious, or more-or-less conscious, attempts to deal with reality. They take the form of disavowal or withdrawal as the subject tries to avoid or circumscribe conflicts encountered in his relationship with the external world.

In “The Neuro-Psychoses of Defense” (1894a), Freud wrote: “There is, however, a much more energetic and successful kind of defense. Here, the ego rejects the incompatible idea together with its affect and behaves as if the idea never occurred to the ego at all. But from the moment at which this has been successfully done the subject is in psychosis” (p. 58)—to which he added in 1896 that “*projection*,” as a “defensive symptom,” signified “*distrust of other people*” (p. 184).

The chief psychotic defenses in Freud’s view were *foreclosure* (*Verwerfung*, reformulated by Lacan in 1956), *projection*, and *delirium*. All of these were in evidence in Freud’s analysis of the case of President Schreber (1912a). The *disavowal* (of reality) as a defense (1927e) was described in the context of the castration complex, particularly in the case of fetishism.



The work of Melanie Klein underscored the major role of the defense mechanism of projective identification in psychotic functioning. Such post-Kleinian authors as Wilfred R. Bion and Donald Meltzer viewed it also as an essential mechanism of psychic growth. Later, other mechanisms became the subject of important conceptual developments: projection, splitting (of ego or object), and the disavowal/idealization pair.

Psychic defenses are not confined to psychotics. Since Bion, they have been deemed a part of the mental functioning of every individual, as long as they have not yet acquired an invasive and systematic quality.

ELSA SCHMID-KITSIKIS

*See also:* Defense; Manic defenses.

### **Bibliography**

Freud, Sigmund. (1894a). The neuro-psychoses of defence. *SE*, 3: 41–61.

———. (1927e). Fetishism. *SE*, 21: 147–157.

Green, André. (1971). La projection: De l'identification projective au projet. In *La folie privée*. Paris: Gallimard.

Lacan, Jacques. (1966). Commentaire sur la *Verwerfung*. In *Écrits*. Paris: Seuil. (Original work published 1956)

### **Further Reading**

Marcus, Eric. (1992). *Psychosis and near psychosis: Ego function, symbolic structure, treatment*. New York: Springer-Verlag.

---

## **PSYCHOTIC/NEUROTIC**

The relationship between the neuroses and the psychoses, or between the neurotic sphere and the psychotic one, cannot be studied from a psychoanalytical point of view without clarifying the meaning of the two terms, considering their reciprocal ties as described in the work of Sigmund Freud and Karl Abraham, and, lastly, reviewing their status today.

With regard to the term *neurosis*, the idea that medicine ought to set aside a nosological and etiopathogenic category to cover conditions presenting functional impairments, in the absence of manifest lesions, which affected the nervous system but not the

brain or any other organ, arose in the classical period in the work of Thomas Willis (1622–1675) and Thomas Sydenham (1624–1689). These authors included as neuroses hysteria, to which they denied a uterine origin, and hypochondria, to which they denied the hepatic genesis attributed to it since antiquity. The word *neurosis* itself was coined in 1777 by William Cullen (1710–1790) to identify a class of generalized as distinct from localized disease which along with the neuroses included fevers and cachexias. Defined as sensory and motor attacks without fever or local disorder, Cullen's "neuroses" encompassed comas, adynamias (to which he assigned hypochondria), spasms (including hysteria), and vesanias.

Nineteenth-century usage veered back and forth between a narrow definition of neurosis limited to hysteria and hypochondria and a broader meaning that embraced syncope, tetanus, epilepsy, chorea, paralysis agitans, and neuralgias. During the last quarter of the century, however, in part due to the advent of dynamic psychology (Pierre Janet, Sigmund Freud) and of semiological neurology (Jules Déjerine, Joseph Babinski, Gordon Holmes), a new system of classification began to take form. Matters were helped, too, by the new discipline of clinical neurology, which laid claim to epilepsy, chorea, Parkinson's disease, and cerebellar syndromes while recognizing psychiatry as the sole proprietor of the neuroses (with the exception of hysterical paralyses, which called for cooperation between the two specialties). Thenceforward the neuroses were understood either in a simple way, as by Pierre Janet, who distinguished only between hysteria and psychasthenia, or in the more elaborate manner of Freud, who contrasted the actual neuroses (anxiety neurosis, neurasthenia, hypochondria) with the so-called defense or transference neuroses (conversion hysteria, phobic neurosis, obsessional neurosis), using criteria that were certainly descriptive but also psychopathological in character.

The term *psychosis* appeared later. Introduced in 1845 by Ernst von Feuchtersleben (1806–1849), it was at first a very general designation for illnesses of the mind ("*Geisteskrankheiten*") as opposed to the neuroses, attributed at the time to malfunctions of the peripheral nervous system. Psychosis thus became synonymous with mental alienation in the most general sense. During the last quarter of the nineteenth century and the first half of the twentieth, when psychiatry started emphasizing the irreducible variety of

mental illnesses, *psychosis* covered all cases within that domain which were clearly not of the nature of neurosis, of dementia, or of mental retardation—in other words, the label was applied to almost all institutionalized mental patients. Psychoses were considered either acute (confusional states, delusional episodes, mania, melancholia) or chronic (schizophrenia, paraphrenias, paranoia), but no answer was offered to the question whether these categories were discrete or whether they were variations expressing a single underlying (psychotic) disease process. (Not to mention issues of etiology or the inflated role assigned to general paralysis.)

In the development of psychoanalysis, the relationship between the psychotic and the neurotic was at first considered a relationship of exclusion, a veritable gulf separating the one from the other, just as, in zoology, vertebrates were radically separated from invertebrates. Little by little, however, a more nuanced view prevailed: for one thing, the two realms were brought much closer together; for another, the question was raised whether a particular place should not be set aside for perversions. Even greater difficulty was met with later, when a pigeonhole had to be found for the borderline states identified in apparently neurotic subjects who, after being accepted as such for psychoanalysis, decompensated during the treatment in a psychotic manner (Kernberg, 1975).

In Freud's early works, those collected in the first two volumes of the *Gesammelte Werke*, a radical distinction between neurosis and psychosis was of a piece with his inaugural discoveries: the neuroses were said to reflect conflicts within the subject whose original sense escaped him, conflicts echoing others in earliest childhood, repressed but accessible in general through a transference relationship and hence accessible to psychoanalysis; the psychoses, by contrast, were related to conflicts between the subject and the outside world, hardly or not at all accessible via a transference relationship, and for that very reason contraindicating psychoanalytic treatment, even though the discourse of psychotic patients might bring directly to light aspects of the unconscious that emerged in neurotics only after many psychoanalytic sessions.

Freud continued to maintain this point of view a little later, in the third part of his commentary on Daniel Paul Schreber's *Memoirs* (Freud, 1911c [1910]), when he put forward the idea that the pathological process common to the various chronic delusional conditions

was denial of homosexual wishes—a mechanism very different from those met with in neurosis.

The work of Karl Abraham presents what is probably the most careful psychoanalytical account not only of the relationship between the neuroses and the psychoses, but also of the relationships between each of them and libidinal fixations and regressions, as well as those of individual neuroses and psychoses to one another (1927 [1924]). Abraham showed in the clearest way, albeit in a nuanced and quite unschematic way, how the received clinical distinctions between schizophrenia, paranoia, mania, and depression might be seen as corresponding to the subdivisions of the oral and anal stages, and how likewise the neuroses related, each after its own fashion, to the genital stage; thus the empirical level of clinical experience could find theoretical support in the psychoanalytic knowledge of libidinal development. This standpoint tended therefore to buttress the view that the neurotic and psychotic spheres should continue be treated as separate, because their respective connections with the libidinal stages were quite distinct. At the same time, as Abraham noted, especially with respect to melancholia and obsessional neurosis, links had to be recognized between particular psychoses and particular neuroses, as for instance the link between schizophrenia and hysteria.

Later on, both the relative simplicity of the neurosis/psychosis distinction and its tendency to become absolute were contested, and the dividing-line was once more brought into question. This clear-cut division had long served a didactic purpose in the professional training of analysts, but even for the most vociferous partisans of the primacy of the totality—of the Germanic *Ganzheit*—training could hardly be founded on a complete absence of distinctions; indeed it was arguable that the usefulness of this clear opposition resided solely in its educational value, and that it should therefore be discarded once training was successfully completed.

The development of his conception of the perversions led Freud to abandon the idea of the primacy of fixation to infantile sexuality (1905d), along with the corresponding view of perversion as the reverse of neurosis, and to assign a major role to the disavowal of reality and the splitting of the ego (1940a [1938]). Since these processes were closely akin to those in play in the psychotic realm, this meant the end of the tidy arrangement that had prevailed hitherto. A difficult choice remained between two possible revisions: to

reincorporate the perversions into the psychoses, or else to abandon the neurosis/psychosis dichotomy by giving the perversions their own category between the other two. The latter course was liable to jeopardize any strict distinction, for it is well known that the only good opposition is a binary one.

GEORGES LANTÉRI-LAURA

*See also:* Abraham, Karl; Acute psychoses; Blank/non-delusional psychoses; "Claims of Psycho-Analysis to Scientific Interest"; Indications and counterindications for psychoanalysis for an adult; Infantile psychosis; Neurosis; Neurotic defenses; Paranoid psychosis; Psychic causality; Psychoanalytical nosography; Psychoses, chronic and delusional.

### **Bibliography**

Abraham, Karl. (1927 [1924]). A short study of the development of the libido, viewed in the light of mental disorders. In his *Selected papers on psycho-analysis*. London: Hogarth.

Freud, Sigmund. (1905d). Three essays on the theory of sexuality. *SE*, 7: 123–243.

———. (1911c [1910]). Psycho-analytic notes on an autobiographical account of a case of paranoia (dementia paranoides). *SE*, 12: 1–82.

———. (1924c). The economic problem of masochism. *SE*, 19: 155–170.

———. (1940a [1938]). An outline of psycho-analysis. *SE*, 23: 139–207.

Kernberg, Otto F. (1975). *Borderline conditions and pathological narcissism*. New York: Jason Aronson.

### **Further Reading**

Jacobson, Edith. (1972). *Depression, comparative studies of normal, neurotic, and psychotic conditions*. New York: International University Press.

Kubie, Lawrence S. (1967). Relation of psychotic disorganization to the neurotic process. *Journal of the American Psychoanalytic Association*, 15, 626–640.

Steiner, John. (1993). *Psychic retreats. Pathological organizations in psychotic, neurotic and borderline patients*. London/New York: Routledge.

---

## **PSYCHOTIC PANIC**

In the psychotic part of the personality, according to Wilfred Bion, anxiety changes into psychotic panic.

Earlier, Melanie Klein (1935) had put forward the view that the first anxieties are psychotic in content and that in the normal development of infants there is a combination of processes by which primitive anxieties of a psychotic nature are bound, worked through, and modified.

Bion investigated the nature of the processes by which anxiety is modified during the 1950s and 1960s. He saw projective identification as the means by which the infant communicates primitive anxieties and emotions to the mother, and her reverie, that is, her containment with alpha function, as the process that modifies her infant's anxieties. If there is a pathological matrix between infant and mother of an adverse endowment and adverse nurture so that the infant's primitive and violent emotions find no container, a primitive disaster is felt to have occurred in which the container has been destroyed and anxiety has turned into psychotic panic. A nameless dread, as Bion also calls psychotic panic, is returned to the infant which threatens to suffuse and annihilate the personality, and from then on development takes a divergent course.

Psychotic panic is the origin, the O, of the ensuing transformation in hallucinosis, rather than, as in the neurotic personality, transformation in thought. Defenses are adopted to avoid the experience of panic by the evacuation of ego functions capable of the experience, and there is an explosive projection of ego pieces, images, beta-elements, and objects, into a space that has no limits.

EDNA O'SHAUGHNESSY

*See also:* Hallucinosis.

### **Bibliography**

Bion, Wilfred R. (1959). Attacks on linking, *International Journal of Psycho-Analysis*, 40 (5–6), 308.

———. (1962). *Learning from experience*. London: Heinemann; New York: Basic.

Klein, Melanie (1935). A contribution to the psychogenesis of manic-depressive states. *International Journal of Psycho-Analysis*, 16 (2), 145–174.

---

## **PSYCHOTIC PART OF THE PERSONALITY**

Clinical discoveries made in work with psychotic patients enabled Wilfred R. Bion to formulate a set of

highly original hypotheses about psychosis. He states these in a classic paper “Differentiation of the psychotic from the non-psychotic personalities” (1957). His hypotheses are that the psychotic part of the personality arises from “a minute splitting of all that part of the personality that is concerned with awareness of internal and external reality, and the expulsion of these fragments so that they enter into or engulf their objects.”

In this way the psychotic personality constructs a universe of bizarre objects in which he is unable to think and suffers existence in a state of hallucinosis. The psychic preconditions in the psychotic personality are: a preponderance of destructive impulses, a hatred of internal and external reality, and the dread of imminent annihilation, all of which lead to the precipitate formation of thin object relations tenaciously held.

The psychotic personality develops “in a manner markedly different” from the neurotic personality. In the same paper Bion continues: “The difference hinges on the fact that this combination of qualities leads to minute fragmentation of the personality, particularly of the apparatus of awareness of reality which Freud described as coming into operation at the behest of the reality principle, and excessive projection of these fragments of personality into external objects.” Because of the destructive attacks on his ego and on any thought that could serve as a link between two objects, and, in addition, the bizarre nature of his world, he feels unable to restore either himself or his objects.

In the psychotic personality projective identification, the primitive defense mechanism discovered by Melanie Klein (1946), is not merely excessive, but has also a different role in that it becomes the predominant psychic operation: It replaces the processes of introjection and regression, and the structuring of the mind performed by repression in the neurotic personality.

In Bion’s view, contact with reality, at least in those patients who are able to attend for analysis, is never entirely lost. He considers it is important clinically to find the neurotic personality which is concealed by the psychotic personality, and also to find the psychotic personality, which exists in everyone.

EDNA O’SHAUGHNESSY

*See also:* Bleger, José; Fragmentation; Disintegration, feelings of (anxieties); Hallucinosis; Learning from experience; Linking, attacks on; Psychotic panic.

### **Bibliography**

- Bion, Wilfred R. (1957). Differentiation of the psychotic from the non-psychotic personalities. *International Journal of Psycho-Analysis*, 38 (3–4), 266–275.
- Klein, Melanie (1946). Notes on some schizoid mechanisms. *International Journal of Psycho-Analysis*, 27, 99–110; reprinted 1952 in Klein, Melanie, Heimann, Paula, Isaacs, Susan, and Riviere, Joan (Eds.), *Developments in Psycho-Analysis*. London: Hogarth; reprinted 1975 in *The Writings of Melanie Klein*, Volume 3, 1946–1963. London: Hogarth.

---

## **PSYCHOTIC POTENTIAL**

The notion of *psychotic potential* was created by Piera Aulagnier, who contributed significantly to the study of the sources of psychosis. Opposing the idea of a seed of psychosis that supposedly exists in every person, she explored the necessary conditions for the psychotic “solution” to be “chosen” by the subject. These conditions were necessary, but not sufficient in themselves, to produce an out-and-out psychosis, the latter being dependent on chance happenings in the life of the subject. Meanwhile, the psychosis would be “potential.”

The notion of predictability is present on two levels in psychotic potentiality. Firstly, it can be understood as a link between, on the one hand, the history and prehistory of a particular subject (on the level of both reality and fantasy), and, on the other hand, the subject they have become by the time they have been characterized in terms of psychopathology. Potentiality is then understood in the temporal sense: as the relation between a past and a present. It then leads, following the same line of argument, to the question of whether the future is predictable on the basis of the present.

Further, psychotic potentiality can also be understood not just in terms of psychogenesis but also in terms of the Aristotelian opposition between potentiality and act: we can be something potentially without this ever being actualized. The idea of psychotic potential is not the result of a diagnosis made on the basis of observable criteria: it is, first and foremost, a counter-transferential feeling, an extremity or an appeal for help that is felt as strange, even dangerous, by the analyst who is able to empathize. It is particularly important that attention be focused on this dimension, right from the first sessions, for the purpose of forestalling

the risk of failure of certain functions linked to the progress of the treatment itself. Aulagnier emphasized the partial character of this process: It is as if the psyche of the patient could function normally, that is to say without being in flagrant contradiction with the common mindset of other subjects in the same culture, while at the same time containing zones of shadow in which a totally different and original kind of functioning operates.

In *La Violence de l'interprétation* (*The Violence of Interpretation*), of 1975, she defined this concept as “the result of the fixation of a primal delirious thought, whose function it is to attempt to reconstruct a fragment missing in the discourse of the other.” It seemed then that psychotic potential would constitute a “solution” to a conflict experienced by the subject in childhood—a conflict that was too early and intense, causing so much suffering that the psychic work involved in surviving turned into “madness.” This is not the only solution. Aulagnier offers three others: the choice of death, in the form of Thanatos triumphant; the development of infantile autism; and the attempt to flee from any thought, any desire which would lead back to the conflict that was the cause of so much suffering. This latter solution is a partial mutilation, but it is not really constructed like a psychotic delirium. Because of this third possibility, the notion of psychotic potential transcends the childhood/age opposition. Rather than harboring, from childhood onwards, such delirious thoughts, the subject can try to whitewash everything that could prompt suffering or conflict. Yet this avoidance itself, which is to say the delirious “solution” itself, which may be understood as preferable to suicide, nonetheless establishes that such deeply troubled thoughts do exist.

Psychotic potential involves not only the setting up of a premature and primal, delirious kind of mentality, which can develop into psychosis in adulthood. It also suggests the idea of a flaw itself created by pushing away the delirious solution—a fault line that constitutes an invitation to delirium anytime the conflict situation is reactivated by events.

The theorization of psychosis by Piera Aulagnier is very different from that of Sigmund Freud, for whom the call to delirium is an attempt at reparation and reconstruction following a rupture between the self and reality (1924b [1923]). This rupture, according to Freud, is based on the “frustration, a non-fulfillment, of one of those childhood wishes which are for ever undefeated”

(p. 151). Contrary to neurosis, where the reparation is carried out at the expense of the id, reparation in psychosis occurs at the expense of the relation to reality. For Aulagnier, the conflict generating psychosis is not located on the level of desire, but on the level of the thinkable, that is to say of self-identification.

Behind the conditions of possibility for psychotic potential to be established, whether it turns into open psychosis or not, lies a particular situation that imposes on the subject a prohibition and/or an obligation to think something that contradicts the logic of the discourse of society. It is not society that transmits the contents of such thoughts; they result from a compromise that allows one to continue to cathect with reality, and to love objects. They amount to so many *para-decathexes*, a term coined by Aulagnier on the model of para-excitations. In extreme cases, the choices are limited: either real death, or psychic death; a decathexis such as the victory of Thanatos, or a delirious reconstruction.

To sum up the essence of psychotic potential, as Aulagnier defined it: at the source of delirious thinking there lies, on the one hand, an intolerable frustration, whose significance is linked to the question of the origin of the subject, the world, pleasure, and so forth; and, on the other hand, an unconquerable desire, which refuses to be reduced to silence and is connected with the identificatory needs proper to the self.

From her earliest texts until her most recent, Aulagnier has emphasized the fundamental quality of this need in these terms: Every self needs to think that its existence makes sense, that it is not, as Shakespeare says, “a tale, told by an idiot, full of sound and fury, signifying nothing.” If such meaning is lacking in the discourse of the one supposed to impart meaning, the father, delirious thinking will, in its primordial way, attempt to accomplish the reconstruction of the missing fragment. This reconstruction will be illusory, but it will be in conformity with the identificatory demands of the self.

SOPHIE DE MIJOLLA-MELLOR

*See also: Apprenti-historien et le maître-sorcier (L'-)* [The apprentice historian and the master sorcerer]; Blank/nondelusional psychoses; Encounter; *Violence of Interpretation: From Pictogram to Statement, The*.

### Bibliography

- Aulagnier, Piera. (1979). *Les destins du plaisir. Aliénation, amour, passion*. Paris: Presses Universitaires de France.
- . (1984). *L'Apprenti-historien et le maître-sorcier. Du discours identifiant au discours délirant*. Paris: Presses Universitaires de France.
- Castoriadis-Aulagnier, Piera. (1975). *La violence de l'interprétation. Du pictogramme à l'énoncé*. Paris: Presses Universitaires de France.
- Freud, Sigmund. (1924b [1923]). Neurosis and psychosis. *SE*, 19: 147–153.
- Mijolla-Mellor, Sophie de. (1998). *Penser la psychose. Une lecture de l'oeuvre de Piera Aulagnier*. Paris: Dunod.

## PSYCHOTIC TRANSFERENCE

The term *psychotic transference* describes the intense and primitive feelings experienced by some patients during analytic sessions; such experiences occur during periods marked by a deep regression, and they are totally real to the patient, which is why a number of authors speak in this connection of delusional or regressive transference.

The concept of psychotic transference is often used to evoke very intense, primitive or undifferentiated experiences and emotions based on part-objects. Some authors use this model in working with patients presenting psychotic crises. Others use it with neurotics, when the relation with the therapist displays primitive and regressive features which are taken to be “psychotic aspects of the personality.”

Freud at first argued, apropos of transference in psychosis, that in psychotics the libido had been withdrawn from the outside world, and that consequently no transference was possible (1914c). Later, however, he moderated this view: “Since then analysts have never relaxed their efforts to come to an understanding of the psychoses. Especially since it has been possible to work with the concept of narcissism, they have managed, now in this place and now in that, to get a glimpse beyond the wall... [T]he mere theoretical gain is not to be despised, and we may be content to wait for its practical application. In the long run even the psychiatrists cannot resist the convincing force of their own clinical material.” Freud noted in this context, in connection with those aspects of psychosis which allow for transference, that “Transference is

often not so completely absent but that it can be used to a certain extent; and analysis has achieved undoubted successes with cyclical depressions, light paranoiac modifications, and partial schizophrenias” (1925d [1924], pp. 61, 60).

In his treatment of psychotic patients, Herbert Rosenfeld (1965) discovered that they did in fact establish a transferential link with the therapist, and he called this phenomenon “transference in psychosis” or “psychotic transference.” He was the first to take an interest in this question after the fashion of Hanna Segal and Frieda Fromm-Reichmann. As for Wilfred R. Bion, when he discussed the psychotic personality, he was referring, in effect, to psychotic transference or delusional transference: “Since contact with reality is never entirely lost, the phenomena which we are accustomed to associate with the neuroses are never absent and serve to complicate the analysis, when sufficient progress has been made, by their presence amidst psychotic material” (1957, p. 267). Bion described the relationship to the analyst as premature, precipitate, intense, tenacious—and founded on projective identification (p. 266).

DAVID ROSENFELD

*See also:* Countertransference; *Ego Psychology and Psychosis*; Negative therapeutic reaction; Psychoses, chronic and delusional; Transference.

### Bibliography

- Bion, Wilfred. R. (1957). Differentiation of the psychotic from the non-psychotic personality. *International Journal of Psycho-Analysis*, 38, 266–275.
- Freud, Sigmund. (1914c). On narcissism: An introduction. *SE*, 14: 67–102.
- . (1925d [1924]). An autobiographical study. *SE*, 20: 1–74.
- Rosenfeld, David. (1992). *The psychotic aspects of the personality*. London: Karnac.
- Rosenfeld, Herbert. (1965). *Psychotic states: A psychoanalytic approach*. London: Hogarth.

## PUBERTY

Puberty was originally defined anatomically and physiologically as the appearance of secondary signs of

sexual maturation that mark the beginning of the adolescent process which will put an end to the period of childhood that had been prolonged by the period of latency. The concepts of puberty and adolescence have been increasingly considered as belonging to the field of psychoanalysis only progressively.

Of course the chapter on the “Transformations of Puberty” in *Three Essays on the Theory of Sexuality* (1905d) is the essential text by Freud on this subject, but to ascertain the reason for the key place this stage assumes in metapsychological development, it is necessary to go back to the early hypotheses on trauma. The seduction theory formulated in the *Studies on Hysteria* (1895d) assumed in effect two distinct scenes separated by puberty. It is this breakthrough from the presexual (albeit already oriented by the phallus to the genital) which gives both chronological and logical meaning to the twin ideas of latency and deferred action.

For Freud therefore, above and beyond the impact it has on the body and the psychological implications of this, puberty is something that *operates*: initially as a real trauma, then later as a logical operand in the seduction-fantasy, where it served to delineate boundaries. That being said, the 1905 essay on puberty and all the preceding work was to be enriched by later discoveries, such as the 1914 theory of narcissism and, in 1924, the second topology and the death drive hypothesis.

What is at stake in puberty is clear from the outset: “With the arrival of puberty, changes set in which are destined to give infantile sexual life its final, normal shape. The sexual instinct has hitherto been predominantly auto-erotic; it now finds a sexual object” (1905d, p. 206). Freud then raises five questions, all of which are still being asked, on the nature of puberty: First of all, how is the erotic destiny of each person, perversion aside, determined by the way in which the pregenital drives are simultaneously placed in submission to and in the service of genitality, which is the sign of normality? Secondly, what is the role, necessary but not sufficient, of the “chemical” factor in causing sexual tension and pleasure, given that even neurosis “greatly resembles” a state of intoxication and want? Thirdly, according to the theory of narcissism how will ego libido and object libido be fused in this moment of anticipated tension and complementarity between the currents of love and sex? Fourthly, how is, in a final renunciation of bisexuality, the man’s “more logical”

development going to then be differentiated from the “involution” of the young woman who willingly rejoins her initial, oral sexual orientations at the same time as she accedes to genitality? Fifth and finally, in what way is the new sexual object, a semblance of the Other sex, at once both new and rediscovered on the basis of the primal objects, the ancestors of the Other sex? In his conclusion devoted to the risks associated with homosexual inversion occasioned by both familial and social milieus, Freud alerts us to the fact that this accession to a sexual relationship which assumes responsibility for the difference between the sexes, does not occur automatically.

For a long time after Freud puberty remained a secondary preoccupation for psychoanalysts. Instead, under the influence of child analysts and fueled in particular by the debates between Anna Freud and Melanie Klein, interest tended to focus on the relationship between earliest infancy and the oedipal period, with adolescence being considered as little more than the outcome of precocious determinants. On the other hand in the field of psychopathology, the side of adolescence, dissociated from puberty, concerned with the trials of socialization and its psychopathological failures, became the privileged focus of study in the texts on this period (Siegfried Bernfeld, August Aichhorn).

Only recently, and especially in Great Britain and France, has interest been renewed in puberty as distinct from the ensemble of adolescent processes, and designated as such as being their origin. Donald Winnicott was the first to recall that it is sexual maturation, not only social exigencies, which reactivate oedipal difficulties, giving rise to murderous and incestuous feelings which were all too easily repressed in childhood when they were unrealizable, and calling for a second oedipal working-through, subject to new ups and downs. Moses Laufer has elaborated on this approach by explicating the more-or-less pathological crises of adolescence using the concept of *breakdown*, reworked from Winnicott, but which is for Laufer a developmental fracture in the integration of the body image which, following puberty, needs to then incorporate the genital organs and allow for a new compromise between masturbatory fantasy and the demands of the superego. With this Philippe Gutton was able to produce the concept of the “pubertal, which is to the psyche what puberty is to the body.” Although he left room for debate, Gutton distinguished distinctly and

chronologically between the category of feelings that refashion the aim of the drive from the phallic to the genital and are oriented towards a new, complementary, part object—and the *adolescens* process, which is a reconstruction of referents and ideals that this genital identity imposes.

On the Lacanian side, which has proved more reticent with respect to the psychogenetic approach, the texts are few and far between: For Françoise Dolto, puberty is a third “moment of synthesis” (after the mirror stage and the Oedipus complex), in the construction of an unconscious body image. Jean-Jacques Rassial views puberty in its somatic, but also psychic aspects, as the Real blow that necessitates an Imaginary reconstruction and a new Symbolic foundation, insofar as this is an adolescent function.

The production of the concept of puberty points toward a certain number of theoretical modifications: First off (and this is borne out by clinical experience), the topological status of puberty, be it individual or social, and which affects not only the ego but also the id and the superego, affirms the autonomy of the psychical from the somatic and the social, because psychic puberty does not always occur at the same time as these two other puberties. Secondly, from a dynamic point of view, Freudian precepts hold that the conflicts taking place during this time are not only the repetition of earlier conflicts, and therefore all psychogenesis, and particularly the pre-pubertal function of the latency period, needs to be rethought. Thirdly, the economic function of the phallus, between drive and representation, is put into question by its separation during this period from the genital that cannot, after all, be reduced to just its imaginary employment.

As is already apparent in Freud’s texts, the transformations of puberty are not a simple issue of psychogenetics, but raise the question of the function of sexuality as a whole. In other words, behind the story that goes from infantile sexuality to so-called adult normality there lies another, about the infantilism of a sexuality that destines the sexual relationship to its failures, which diverge according to the sexual genital in question.

JEAN-JACQUES RASSIAL

*See also:* Adolescence; Genital stage; Psychosexual development; *Three Essays on the Theory of Sexuality*.

### **Bibliography**

- Freud, Sigmund. (1905d). Three essays on the theory of sexuality. *SE*, 7: 123–243.
- Gutton, Philippe. (1991). *Le pubertaire*. Paris: Presses Universitaires de France.
- Laufer, Moses, and Laufer, Egle. (1984). *Adolescence and developmental breakdown: a psychoanalytic view*. New Haven, CT: Yale University.
- Perret-Catipovic, Maja, and Ladame, François (Eds.). (1997). *Adolescence and psychoanalysis: The story and the history* (Philip Slotkin, Trans.). London: Karnac.
- Rassial, Jean-Jacques. (1990). *L'Adolescent et le psychanalyse*. Paris: Payot.

### **Further Reading**

- Bloch, H. Spencer. (1995). *Adolescent development, psychopathology, and treatment*. Madison, CT: International University Press.
- Laufer, Moses. (1996). The psychoanalyst of the adolescent. *Psychoanalytic Study of the Child*, 51, 512–521.

---

## **PUERPERAL PSYCHOSES**

Derived from the Latin *puerpera* (“woman in childbirth”), *puer* (“child”), and *parere* (“to give birth”), the term *puerperal psychoses* conventionally comprises all the psychiatric conditions with onset during pregnancy and in the year following it. In a more restricted sense, the same term is used as the equivalent of *post-partum psychoses*, in which case it concerns only major, acute problems that occur during the days or first month immediately after delivery.

Puerperal disorders have been known since antiquity (Hippocrates, Galen). Puerperal psychoses were singled out in the mid-nineteenth century, with the work of Jean-Étienne Esquirol (1838) and Louis-Victor Marcé (1858). Still relevant from that time are questions that treat the specificity of these morbid states: Are they an autonomous clinical entity of which childbirth is the causal agent? Or, instead, is childbirth merely an event that precipitates the emergence of a psychiatric syndrome in an already vulnerable woman?

Psychoanalysis very early on became interested in this pivotal stage in a woman’s life. Paul-Claude Raca-



mier, in “La mère et l’enfant dans les psychoses du post-partum” (Mother and child in the postpartum psychoses; 1961), defined puerperal disorders as accidents in the psychoaffective “process” of motherhood—a process that can be understood in light of concepts developed by Sigmund Freud: the castration complex, its impact within narcissism, and its clinical consequence, penis envy, which becomes the desire to have a child by the father during the oedipal phase. Above all, Freud discovered the strength of the bond uniting the little girl with the preoedipal mother and its articulation with the central problem of identification.

Beginning in the 1970s analytic understanding of the processes of motherhood and its avatars was opened up to contributions from other disciplines, such as developmental psychology, ethology, or the practice of observation. A number of theoretical and/or clinical concepts have since become available: primary maternal preoccupation (Donald Winnicott), the capacity for maternal reverie (Wilfred Bion), projective identifications (Melanie Klein, Bion), behavioral and fantasmatic mother-child interactions, transgenerational transmission (Mary Ainsworth, Serge Lebovici), or the motherhood constellation (Daniel N. Stern).

ODILE CAZAS

See also: Infant observation (therapeutic); Parenthood; Postnatal/postpartum depression.

### Bibliography

- Ainsworth, Mary D. Salter, Blehar, M. C., Waters, E., and Wall, S. (1978). *Patterns of attachment: A psychological study of the strange situation*. Hillsdale, NJ: Erlbaum.
- Cazas, Odile, Dhôte, Alain, Bouttier, Daniel, and Ginestet, Daniel. (1990). L’hospitalisation conjointe de la mère et de son nourrisson dans un service de psychiatrie adulte. *Psychiatrie de l’enfant*, 33 (1), 635–674.
- Esquirol, Jean Étienne. (1838). *Des maladies mentales considérées sous les rapports médical, hygiénique et médico-légal*. Paris: J. B. Baillière.
- Lebovici, Serge. (1983). *Le nourrisson, la mère et le psychanalyste*. Paris: Le Centurion.
- Marcé, Louis-Victor. (1858). *Traité de la folie des femmes enceintes, des nouvelles accouchées et des nourrices et considérations médico-légales qui se rattachent à ce sujet*. Paris: J. B. Baillière.
- Racamier, Paul-Claude. (1961). La mère et l’enfant dans les psychoses du post-partum. *L’Évolution Psychiatrique*, 4, 525–570.
- Stern, Daniel N. (1995). *The motherhood constellation: A unified view of parent-infant psychotherapy*. New York: Basic Books.
- Winnicott, Donald W. (1958). Primary maternal preoccupation. In *Collected papers, through paediatrics to psycho-analysis*. London: Tavistock. (Original work published 1956)

## PUNISHMENT, DREAM OF

In punishment dreams, the dreamer is explicitly or implicitly punished for a fault, often indicated as excusable or unknown to the dreamer.

In the 1911 revision of *The Interpretation of Dreams* (1900a), Freud included an analysis of a dream of the famous Austrian poet Peter Rosegger. Freud associated the dream with his own memories of a time when, working in the physiological laboratory under the German physician Ernst Brücke, he admonished himself in a dream for boasting about his scientific and social success.

In another emendation, in 1919, Freud introduced the theme of punishment dreams into chapter 7, on the fundamental psychology of the dream processes. The painful quality of dreams of punishment seems to contradict the theory that a dream represents a gratification of a wish. Freud asserted that dreams of punishment indeed represent precisely the wish to be punished, to expiate a fault. In this process, there is no return of a repressed wish but rather a need for punishment that originates with the ego or rather (as he soon would call it, in a note added in 1930) the superego.

In *Introductory Lectures on Psycho-Analysis* (1916–1917a [1915–1917]), Freud explored the relationship between punishment and dreams in the chapter devoted to wish fulfillment. In “Some Additional Notes on Dream-Interpretation as a Whole” (1925i), Freud, in discussing the content of dreams in terms of moral responsibility, laid stress on the ego’s censorship of the wishes of the id. In *New Introductory Lectures on Psycho-Analysis* (1933a), in the chapter on the revision of the theory of dreams, Freud emphasized the superego’s role of repression. The questions Freud posed apropos of punishment dreams are also related to repetition compulsion, discussed in *Beyond the*

*Pleasure Principle* (1920g) and *The Economic Problem of Masochism* (1924c).

ROGER PERRON

*See also:* Dream; Guilt, feeling of; Need for punishment; Self-punishment; Superego.

### **Bibliography**

- Freud, Sigmund. (1900a). The interpretation of dreams. *SE*, 4: 1–338; 5: 339–625.
- (1916–1917a [1915–1917]). Introductory lectures on psycho-analysis. *SE*, 15–16.
- (1920g). Beyond the pleasure principle. *SE*, 18: 1–64.
- (1924c). The economic problem of masochism. *SE*, 19: 155–170.
- (1925i). Some additional notes on dream-interpretation as a whole. *SE*, 19: 123–138.
- (1933a). New introductory lectures on psycho-analysis. *SE*, 22: 1–182.

## **PURIFIED-PLEASURE-EGO**

In 1911 Freud, in “Formulations on the two principles of mental functioning” (1911b [1910]), distinguished between a *pleasure-ego* “that can do nothing but *wish*, work for a yield of pleasure, and avoid unpleasure,” and a *reality-ego* that “need do nothing but strive for what is *useful* and guard itself against damage” (p. 223), then, in 1915 he described a “purified-pleasure-ego” (p. 136) in the course of his metapsychological reflections on “Instincts and Their Vicissitudes” (1915c).

The purified pleasure-ego is the result of a distinction between an ego and a non-ego, and the splitting of both the external and internal world into what is pleasurable and what is not. Certain instincts are considered to be unpleasant and are then rejected or rather “projected” outside, whereas objects that are a source of satisfaction are “introjected.” “The original reality-ego, which distinguished internal and external by means of a sound objective criterion, changes into a purified ‘pleasure-ego’, which places the characteristic of pleasure above all others. For the pleasure-ego the external world is divided into a part that is pleasurable,

which it has incorporated into itself, and a remainder that is extraneous to it. It has separated off a part of its own self, which it projects into the external world and feels as hostile” (p. 136).

We find these same distinctions unchanged in the article entitled “Negation”: “The original pleasure-ego wants to introject into itself everything that is good and to eject from itself everything that is bad. What is bad, what is alien to the ego and what is external are, to begin with, identical” (1925h, p. 237).

Following the example of Melanie Klein, who was inspired by this notion to describe projective identification (Manual Furer, 1977; James Grotstein, 1994), the majority of Anglo-Saxon writers who have described the first phases in the development of the mind have referred to this “purified pleasure-ego” as linked to the splitting into “pleasant” and “unpleasant” which becomes “good” and “bad.” The symbiotic phase described by Margaret Mahler is very close to this (Julio Granel, 1987). And Heinz Kohut goes so far as to indicate in a footnote in *Forms and Transformations of Narcissism* (1966) that “The purified pleasure ego may be considered as a prestage of the structure which is referred to as the narcissistic Self in the present essay” (p. 246n).

ALAIN DE MIJOLLA

*See also:* Ego; Illusion; “Instincts and their Vicissitudes”; Internal object; Grandiose self; Pleasure ego/reality ego; Primary object; Projection; Reality principle; Shame; Symbiosis/symbiotic relationship; Turning around.

### **Bibliography**

- Freud, Sigmund. (1915c). Instincts and their vicissitudes. *SE*, 14: 109–140.
- Furer, Manuel (1977). Psychoanalytic dialogue: Kleinian theory today. *Journal of the American Psychoanalytic Association*, 25, 371–385.
- Granel, Julio A. (1987). Considerations on the capacity to change, the clash of identifications and having accidents. *International Review of Psycho-Analysis*, 14, 483–490.
- Grotstein, James S. (1994). Projective identification and countertransference: a brief commentary on their relationship. *Contemporary Psycho-Analysis*, 30, 578–592.
- Kohut, Heinz. (1966). Forms and transformations of narcissism. *Journal of the American Psychoanalytic Association*, 14, 243–272.

## PURPOSIVE IDEA

Sigmund Freud used the term *purposive idea*, above all in his early psychoanalytic writings, to refer to the orienting role of an idea when it is conducive to the sudden appearance of a train of thought (ideas, affects, representations, fantasies, and so on). The stages in this train of thought converge in the direction of this idea, which thus itself seems to be the goal of all of this psychic work.

Freud's main discussion of this notion is found in *The Interpretation of Dreams* (1900a; chapter 7, section 1); thereafter he returned to it only sporadically. His aim in this passage was to refute an objection that had been raised against his method of dream analysis by means of free association; his critics contended the material produced in this way could consist only of isolated fragments and could have no overall meaning. This objection came out of an understanding of associationism in which, at the time, ideas that thus appeared "by chance" could only be brought together based on formal criteria (synonymy, assonance, and so on) or chance (temporal coincidence, for example). It is remarkable that Freud, who elsewhere made extensive use of these formal or contingent factors in association, in this passage challenged the idea of a train of thought occurring by chance. He pointed out that conscious thought is always directed toward a goal to be reached (solution of a problem, preparing for an action, and so on). The same is true, he said, when a train of thought is unconscious and/or bears upon representations that are themselves unconscious: It is always directed toward a goal, even if the subject is unaware of it. Thereafter, when someone was asked, after relating a dream, to proceed by free association, the sequence of the dreamer's evocations followed an orientation homologous to the one that presided over the dream-work, a process in which the goal to be reached was the fulfillment of a wish. The same applied in the analysis of a symptom, homologous to the work of producing this symptom, which could thus be decrypted.

Thus, although Freud subsequently returned to this term only intermittently in his later works, he based the notion on two essential principles: First, the elements of thought, notably representations, are linked together in an ordered sequence (the analysis of several such trains of thought leading in general to a "nodal

point" at the heart of the subject's problematics); and, second, this sequence is ordered by a finality.

ROGER PERRON

*See also:* Fundamental rule; *Interpretation of Dreams*, *The*.

### Bibliography

Freud, Sigmund (1900a). The interpretation of dreams. Part I., *SE*, 4: 1–338; Part II, *SE*, 5: 339–625.

## PUTNAM, JAMES JACKSON (1846–1918)

American physician and neurologist James Jackson Putnam was born on October, 3, 1846 in Boston, where he died on November 4, 1918.

His family belonged to New England's professional aristocracy. Both his father and grandfather were prominent physicians. His mother admonished him to be good, honest, and not to entirely neglect his social obligations. He studied medicine at Harvard University. In 1870, he went to Europe to learn about electrotherapeutics and neurology, concentrating on anatomy and pathology—whose proponents believed that mental diseases were due to defective heredity, and that brain and mind were parallel systems. He became one of America's most distinguished specialists in nervous diseases.

By the mid-1890s, with, among others, William James, Josiah Royce, and Morton Prince, Putnam experimented with hypnosis and psychotherapy. His practices were rooted in the ideas of Janet, Bernheim, and Charcot, as well as in the virtue and belief in progress that, habitually, was taught to the members of New England's professional aristocracy. He was aware of Freud's work, and after meeting Ernest Jones (who then was in Toronto), he began to think that early experiences and childhood sexuality might be important elements in later neuroses and psychoses. Thus, he came to psychoanalysis at the age of sixty-three.

Together with William James, Putnam went to hear Freud's lectures at Clark University in 1909. He was impressed and invited Freud (along with Carl Jung and Sándor Ferenczi) to his camp in the Adirondacks. Nathan Hale (1971b, p. 25) demonstrates that there they forged a friendship, and Putnam became "convinced of Freud's integrity and sincerity, and from then on marshalled all his energies, prestige, and elo-

quence, on behalf of psychoanalysis.” Until his death, he lectured on psychoanalysis at Harvard and published twenty-two papers on the subject.

In that period, Putnam and Freud exchanged eighty-eight letters, and Freud analyzed Putnam during psychoanalytic congresses. At Freud’s urging, Putnam initiated the founding of the American Psychoanalytical Association in 1911, and the Boston Psychoanalytic Society in 1914. He fiercely defended psychoanalysis against scurrilous attacks. However, Putnam rejected Freud’s bent toward materialism and determinism, and Freud objected to Putnam’s idealistic and philosophical formulations—which led him to urge his patients to ennoble their minds—and to the belief that individuals are ruled by an inherent principle of growth.

In *Totem and Taboo* Freud particularly rebutted the religious elements of Putnam’s book *Human Motives*, although already before then Putnam’s ideas allegedly had influenced him. Putnam’s convictions originated in his Unitarian upbringing; in Bergson’s belief that memory images are not “stored” in the brain but called up by the sensory-motor system; in his patient’s, Susan Blow’s, argument that “self-activity” expresses the self-determining energy of life; and in Royce’s faith in an unseen ideal.

Throughout his life, Putnam was concerned with the moral crises which, in America, were arising out of an ingrained “civil morality”—that engendered hidden conflicts due to expectations of religious purity in upwardly mobile men who were having illicit affairs. Because Putnam’s case notes were destroyed, we do not know how he conducted his therapies. But his stature and esteem, and his dedication to psychoanalysis, were decisive in establishing the discipline on the North American continent.

EDITH KURZWEIL

*See also:* United States.

### **Bibliography**

- Freud, Sigmund. (1912–13a). Totem and taboo. *SE*, 13: 1–161.
- Hale, Nathan G. Jr. (1971a). *Freud and the Americans: The beginnings of psychoanalysis in the United States, 1876–1917*. New York: Oxford University Press.
- Hale, Nathan G. Jr. (1971b). *James Jackson Putnam and psychoanalysis*. Cambridge, MA: Harvard University Press.
- Putnam, James Jackson. (1915). *Human motives*. Boston: Little, Brown, and Company.



# Q

## QUANTITATIVE/QUALITATIVE

*Qualitative* and *quantitative* are two indissociable adjectives applied to the concept of affect in psychoanalytic theory. From Sigmund Freud to André Green, affect has been approached in terms both of its dynamic (quantitative) and subjective (qualitative) dimensions.

The relationship between these two terms evolved in Freud's work at the same time as the relationship between representation and affect. Initially, representation took priority over affect, the latter being assigned a function of mere coloring, and the emphasis was on the quantitative dimension. As subsequent theoretical revisions were effected, affect took on importance and was no longer studied only in terms of its relationship to representation, and the qualitative dimension thus was given growing prominence.

*Quantity* was the term that appeared first, in an article written by Freud for Villaret's Encyclopedia (1891). In *Studies on Hysteria* (1895) Freud took up the term again and used it in an economic sense in his description of the excitation present in the nervous system and its vicissitudes. He took his inspiration from the scientific model of thermodynamics: The psychic apparatus seeks to maintain the sum of excitation at the lowest possible level, either by spreading it out by means of association, or by discharging the surplus.

Freud approached the quantitative and qualitative dimensions together for the first time in "Project for a Scientific Psychology," which was written in 1895 but never published during his lifetime. Although what was at issue was not yet affect but rather psychic energy, the fundamentals of Freud's future hypotheses

can be discerned in this text. He had not yet abandoned the idea of a scientific career in biology, and, as he explained in the introduction, was seeking to bring psychology into the framework of the natural sciences. He divided the psychic apparatus into systems ( $\phi$  system of permeable neurones,  $\psi$ -system of impermeable neurones, and  $\omega$ -system of perceptual neurones) in which the psychic processes are quantitatively determined states of material particles, the neurons. The  $\phi$  system refers to exogenous and physical quantities, while the system  $\psi$  refers to internal, mental quantities. The quantity  $Q$  derives from hypotheses he had already proposed in an article written the previous year, "The Neuro-Psychoses of Defence," (1894) in which he distinguished measurable quantity, its variations, the movement associated with this quantity, and its discharge.

The affects are thus, according to Freud, internal, secreted discharges. The taking into account of quality is subordinated to this dynamic conception. He had difficulty in approaching this dimension, and for this purpose introduced the third system,  $\omega$ , which he linked to perception. This system is aroused by perceptions, and it is the discharge of this excitation that produces a quality. Further on, he specified that quality appears where the quantity  $Q$  has been reduced beforehand. All this thus amounts to the transformation of an external quantity into a quality. Qualitative phenomena are brought back to the vicissitudes of quantity, an idea that Freud expresses in his statement that the tendency to avoid unpleasure is blended with the primary tendency toward inertia. This implies communication between the  $\psi$  and  $\omega$  systems.

Freud put considerable emphasis on the sensation of a psychic modification giving the impression of an

internal movement, in this way relating indices of quality to information about discharge. Attention is thus brought to bear both on indices of quality belonging to the external properties of the object and on the internal processes of the passage of a psychic quantity,  $Q$ . Because he did not allude on this occasion to the  $\omega$  system, it is impossible to say whether it is this system that provides this perception of movement. The confusion grows even further in a correction Freud sent to Fliess, in which he specified that the  $\omega$  system serves only to excite, that is, it is limited to indicating the path to be followed; this would imply that unconscious processes remain unconscious and can acquire only a secondary and artificial consciousness by being linked to processes of discharge and perception.

With *The Interpretation of Dreams* (1900), Freud effected an epistemological break and renounced the biological model, but he nevertheless remained unclear about the qualitative, which remained subordinated to the quantitative. He stressed the quantitative, dynamic aspect of the repression of representations. Affect, independent of the latter, is not transformed in dreams; its quality remains unchanged, although its content is suppressed.

Up until his metapsychological writings of 1915 (“Instincts and Their Vicissitudes,” “Repression”), Freud distinguished two very different things: representation (or ideation) on the one hand, and on the other, the quota of affect representing the instinct. The two have very different vicissitudes. The quota of affect corresponds to instinct that is detached from representation and that finds expression, proportionate to its quantity, in processes that are experienced as affects. This amounts to saying that there are only quantitative differences between different instincts that are qualitatively alike. Freud then pursued this line of thinking and posited a duality between the quantitative factor with representation, on the one hand, and the qualitative factor with affect, on the other. He distinguished the ideational representative from the representative of affect, with the two having different fates. The first disappears from consciousness under the effects of repression. The second has three possible outcomes: suppression of the instinct, expression of a qualitatively defined affect, or transposition of the psychic energy of the instincts into affects.

Not until 1924, with the article “The Economic Problem of Masochism,” did Freud come to recognize the relative independence of quantity and quality. At

this point he dissociated states of pleasure and unpleasure from the economic factors of relaxation and tension, and distinguished the Nirvana principle, on the one hand, from the pleasure principle, on the other. The former has the purely quantitative task of reducing the level of psychic energy to zero. The latter is responsible for the qualitative avoidance of unpleasure and the search for pleasure. Affect is thus found in an intermediate position between annihilation by means of discharge, and the desire to transcend it.

After Freud, others continued to investigate the connection between the quantitative and qualitative aspects of affect. There remained, however, a tendency to approach affect only in its quantitative dimension, neglecting its qualitative dimension. Only with Green’s book, *The Fabric of Affect in Psychoanalytic Discourse* (1973/1999), in which he attempted to develop a metapsychology of affect and representation, was the relationship between quantitative and qualitative significantly reexamined. Green described two poles of affect, one economic and the other psychic, that are most often complementary. In its economic aspect, affect can be considered as a quantity of dischargeable energy. This is the primary dimension of affect, closer to the id than to representation, but difficult to distinguish from the latter. In its psychic aspect, the movement of discharge is only incipient, and is overridden by the qualitative dimension. It is found in the form of the pleasure/unpleasure dichotomy, which for Green is “the principle of primary symbolization.”

PHILIPPE METELLO

*See also:* Desexualization; Discharge; Erotogenic masochism; Instinctual representative; Otherness; Pleasure/unpleasure principle; Principle of (neuronal) inertia; “Project for a Scientific Psychology, A”; Quota of affect; Reciprocal paths of influence (libidinal coexcitation); Representation of affect; Hard science and psychoanalysis; Sum of excitation.

### **Bibliography**

- Freud, Sigmund. (1915c). Instincts and their vicissitudes. *SE*, 14: 109–40.
- . (1915d). Repression. *SE*, 14: 141–58.
- . (1924c). The economic problem of masochism. *SE*, 19: 155–70.
- . (1950c [1895]). A project for a scientific psychology. *SE*, 1: 281–387.

Green, André. (1999). *The fabric of affect in psychoanalytic discourse* (Alan Sheridan, Trans.). London and New York: Routledge. (Original work published 1973)

## QUASI-INDEPENDENCE/TRANSITIONAL STAGE

In Fairbairn's revision of classical developmental theory, based in object-relationships rather than libido theory and underlying his theories of psychopathology, quasi-independence, or transitional stage, occurs between the stages of infantile dependence and mature dependency, and is characterized by dichotomy and exteriorization of the incorporated object.

Fairbairn's view of the ego as inherently object-seeking rather than pleasure-seeking, and invested with its own energy, facilitated his move away from instinct/libido theory and psycho-sexual development as delineated by Freud and later Abraham, and allowed him a revised theory of development based on object-relations. He proposed an early stage of infantile dependence, or primary identification, the object, while still part of the relationship, not yet being differentiated, and the aim (libido) being incorporative, "taking."

Fairbairn described the gradual transformation of quasi-independence into an object-relationship in which the subject and object are fully differentiated, and the aim is "giving," the stage of mature dependency. In the transition between these stages the object has split into the accepting (loved) and the rejecting (hated) object, attached to the libidinal and antilibidinal egos respectively, and increasing differentiation results in attempts to "exteriorize" these objects, modelled on the known physiological experiences of defecation and urination.

The characteristic conflict of the transitional/quasi-independent stage is between the developmental urge towards mature dependence and the regressive reluctance to relinquish infantile dependence, and Fairbairn described four transitional stages, or rejective techniques, the paranoid, obsessional, hysterical, and phobic, each consisting of different internal relationships and mechanisms, and each underlying specific psychopathologies.

Based neither on the sequence of erotogenic zones, nor on "positions," Fairbairn's developmental theory is a more psychological and object-related theory than

that of either Freud or Klein, and allows considerable flexibility of theoretical and clinical approach. These ideas have been particularly useful to British Independent analysts, and those interested in self-psychology and intersubjective analysis.

JENNIFER JOHNS

*See also:* Fairbairn, William Ronald Dodds; Object relations theory.

### *Bibliography*

- Fairbairn, Ronald. (1952). A revised psychopathology of the psychoses and psychoneuroses. In *Psychoanalytic studies of the personality* (pp. 28–58). London: Tavistock with Routledge, Kegan Paul. (Reprinted from *International Journal of Psycho-Analysis*, 22 (1941), 250–279.)
- Greenberg, Stephen, and Mitchell, Jay (1983). *Object relations in psychoanalytic theory*. Cambridge, MA, and London: Harvard University Press.
- Grotstein, James, and Rinsley, Donald (Eds.). (1994). *Fairbairn and the origins of object relations*. London: Free Association Books.

## QUATRIÈME GROUPE (O. P. L. F.), FOURTH GROUP

The Quatrième groupe (Fourth group) of the Organisation psychanalytique de la langue française (O. P. L. F., French-Language Psychoanalytic Group) is one of the larger psychoanalytic groups in France. It claims to follow principles and methods that have opened up a third way between Lacanism and the standards of the International Psychoanalytical Association.

The Quatrième groupe was born out of the third split in the French psychoanalytic movement, which occurred in March 1969. This was after the 1953 split, which gave rise to the Société française de psychanalyse (French Psychoanalytic Society), and the 1963 split, which divided the Société française de psychanalyse into the Association psychanalytique de France (French Psychoanalytic Association) and the École Freudienne de Paris (Freudian School of Paris), created by Jacques Lacan.

The founders of the Quatrième groupe—Piera Aulagnier, François Perrier, and Jean-Paul Valabrega—had been members of the first board of directors of the École Freudienne de Paris, but very soon, with the



resignation of Perrier in 1967, followed by that of Valabrega, they reproached him for setting up institutional formations that he had previously criticized. In addition to this criticism of Lacan's leadership, the direct cause of the split was their rejection of new modes of psychoanalytic training (the "pass") that Lacan had just put in place in December 1968.

The first of the meetings that would result in the formation of the Quatrième groupe took place in Ermenonville, north of Paris. The group was officially founded on March 17, 1969, and at first included only ten people. Its officers were François Perrier, president; Jean-Paul Valabrega, vice-president; Piera Castoriadis-Aulagnier, psychoanalytic secretary; Evelyne-Anne Gasquères, scientific secretary; Jean-Paul Moreigne, administrative secretary; and Gabrielle Dorey, treasurer.

The Quatrième groupe was founded on considerations of both the essence of psychoanalysis and the form of institution most likely to sustain the principles of its practice and transmission. These considerations resulted from the experience of the Société française de psychanalyse, in which Lacan was the major driving force, but also from a critique of both the institution and practice of Lacanism (most notably, the short sessions). This critique lent its tone to the Quatrième groupe's declaration of principles and methods: "Between the idealism of principles and the authoritarianism of ideologies, it is appropriate to pinpoint difficulties and to define the impossible. . . . It will be found that the three terms of 'ability,' 'membership,' and 'training' are a source of insoluble conflicts and the sticking points of post-Freudianism" (*Topique*, 1 [1969]).

The issue of ability was linked to that of the effects of the training analysis, which is particularly dangerous if the training analysis is defined as Lacan did, that is, as aiming at "pure," as opposed to "applied," analysis. The issue of membership opened up the possibility of feudal loyalty based solely on analytic affiliations. And the issue of training raised the risk of basing the status of analyst on the attainment of a diploma or on the rituals of collegial recognition. This triple preoccupation can be summed up as a concern over whether an analytic society can manage to banish "alienation" (Mijolla-Mellor, 1996), and it is the basis of a functional mechanism for coping with this difficulty.

The Quatrième groupe's declaration of principles and methods ultimately made up what would be called the "Blue Notebook," that is, the founding charter of 1969 (*Topique*, 1 [1969]), along with later modifica-

tions to that charter in 1970 (*Topique*, 6 [1971]), in 1983 (*Topique*, 32 [1983]), and in 1985 and 1986 (*Topique*, 38 [1986]). These successive modifications were aimed at "refounding" the institution (during "refounding" sessions) in order to avoid ossification.

The two main points of its principles and methods were the following: First, the composition of the group was limited to two categories of membership. Those in the first category were successively called *tenured* members, then *subscribing* members, and finally *member analysts*. Those in the second category were called *candidates*, then *contributors*, and then *participants*. They were not considered *trainees*, and their status did not guarantee their potential careers as analysts. They were defined as *guests*—either as colleagues already authorized by other societies or as *auditors* in the midst of their analyses who wanted to attend the Quatrième groupe's scientific events (such as seminars and lectures) or participate in its institutional activities (as observers). Passage from the status of participant to that of member analyst posed difficult issues of recognition and the process of authorization.

Second, at the end of a personal analysis, which was not distinguished from a training analysis, whether with a member of the Quatrième groupe or not, the candidate analyst, who was usually a participant member, could decide to undertake a "fourth analysis" (*analyse quatrième*) with a member analyst. The fourth analysis is a private act based on an agreement between the person who requests it and the analyst who agrees to it. After one or more fourth analyses, during which the applicant not only develops an analytic ear (under supervision) but also learns to pinpoint the effects that identification with one's own analyst can have on one's practice, the candidate begins a process of authorization that takes place in between analyses. This process consists of a series of meetings with member analysts who have been chosen by the candidate and have agreed to the request. The "fourth analyst" may or may not be among them. During these interanalytic meetings there is discussion of a case or any analytic question posed by the participants. After at least two or three of these meetings, there are more meetings with other analysts, always chosen by the candidate. At the end of this usually long process, one of the meetings is declared to be "authorizing" by the member analysts in attendance. They have the responsibility,

with the agreement of the whole group, of deciding on the authorization of the new member analyst and reporting it to the ratifying assembly. At any time, the candidate can request the participation of an “analytic secretary,” a member elected by the officers of the Quatrième groupe, if the candidate thinks it would be useful. The secretary has no decision-making power over the candidate. Obviously, this procedure does away with training analysts and the status of trainee. Yet it is strictly codified so that candidates can be authorized only through this process.

This procedure has several advantages. Even if there were no committees, commissions, or boards of admissions, the analytic and scientific secretaries would still provide applicants the possibility of discussing the soundness of their interests and abilities. Moreover, member analysts, merely by being chosen to participate in interanalytic meetings, also contribute to advancing the process of recognition. Consulting analysts thus fulfill their roles as institutional representatives, as opposed to the collective lack of responsibility favored by centralized bureaucracies. In addition, whether it is a matter of the interanalytic meetings or of the authorization itself, any conclusions reached or decisions made must be discussed in the presence of the candidate. Finally, the several fourth analyses and several interanalytic meetings guarantee the principle of multiple references in the process of training so that authorization is not reduced to a kind of feudal initiation based on personal loyalty. Naturally, at every step in the process the candidate's own analyst is prohibited from intervening.

In its earlier formulations, the process of authorization also included a final step in which the candidate would write a memoir to be presented to the whole group at a scientific assembly. This presentation marked the moment of the candidate's acceptance. Even though this practice is no longer followed in quite the same form, candidates, over the course of the long process of authorization, still present their work in meetings of working groups and also possibly at conferences or in scientific journals.

The mechanisms that the Quatrième groupe has put in place aim at responding to a major problem in analytic societies and the principle cause of their dissolution, namely the question of training and authorization. The status of analyst is problematic in that it can only be put to the test during treatment, in the face of an ungraspable entity, the unconscious.

A statement added to the “Blue Notebook” in 1983 concludes, “Our model of analytic training and authorization does not pretend to be permanent or perfect. It would be good if Winston Churchill's statement about democracy could be applied to it: that it is ‘the worst form of government, with the exception of all the others.’”

SOPHIE DE MIJOLLA-MELLOR

See also: Fourth analysis, Analyse quatrième; France; Pass, the; Splits in psychoanalysis.

### **Bibliography**

- Aulagnier, Piera. (1986). *Un interprète en quête de sens*. Paris: Ramsay.
- Mijolla, Alain de. (2001). Splits in the French psychoanalytic movement between 1953 and 1964. In R. Steiner and J. Jonas. (Eds.), *Within Time and Beyond Time* (pp. 1–24). London: Karnac.
- Mijolla-Mellor, Sophie de. (1996). Aliénator, ou les enjeux théoriques de la troisième scission dans le mouvement psychanalytique en France. *Cliniques méditerranéennes*, 49–50, 79–93.
- Valabrega, Jean-Paul. (1994). *La formation du psychanalyste*. Paris: Payot.

---

## **QU'EST-CE QUE LA SUGGESTION? [WHAT IS SUGGESTION?]**

The questions raised in the nineteenth century concerning hypnosis and suggestion continue to preoccupy. It is part of the legend that Freudian psychoanalysis grew out of these practices and distanced itself from them, and Freud himself was careful to establish this part of the legend. In daily life the fascination of these states of mind remains, similar to the state of being in love, and the various other seductions that operate in the social realm. However, psychoanalysts continue to question the nature of Freud's concept, which associated hypnosis with the wielding of influence. Some feel that psychoanalysis is no longer dependent on the all-seeing eye of one person; is manipulation necessary in the therapeutic relation, or suggestion the guide along the path to freedom?

Is suggestion necessary or best avoided? Is it a method of control, or a forced passage toward true reappropriation of the self? The concerns confronting

Charles Baudouin are still present in the early twenty-first century. Initially he published a study, *Suggestion and Autosuggestion* (1920/1962). This he followed in 1924 with the basic question: *What Is Suggestion?*

Baudouin questioned the power of suggestion and the different conceptions of it at the time. He did not believe it was purely an outside influence; he was absolutely convinced that all effective suggestion is basically autosuggestion, that it is part of the psychology of the subject and not constructed of some social psychology in which several different individuals are in relation with each other.

For a while he seemed to draw closer to Émile Coué. He always believed in the power of autosuggestion for the development of the subject, particularly in the context of education. His book develops landmarks in working with the problems posed to him. Is suggestibility in a person normal or pathological? Can there be suggestion without hypnosis? Why should autosuggestion be truly preferable?

MIREILLE CIFALI

See also: Autosuggestion; Baudouin, Charles.

### Source Citation

Baudouin, Charles. (1924). *Qu'est-ce que la suggestion? Introduction à la psychologie de la suggestion et de l'autosuggestion*. Neuchâtel-Paris: Delachaux & Niestlé.

### Bibliography

Baudouin, Charles. (1962). *Suggestion and autosuggestion, a psychological and pedagogical study based upon the investigations made by the new Nancy school* (Eden and Cedar Paul, Trans.). London: G. Allen & Unwin. (Original work published 1920)

Erickson, Milton H. (1967). *Advanced techniques of hypnosis and therapy* (Selected papers of Milton Erickson edited by Jay Haley). New York, London: Grune & Stratton.

Roustang, François. (1990) *Influence*. Paris: Minuit.

———. (1994). *Qu'est-ce que l'hypnose?*. Paris: Minuit.

---

## QUESTION OF LAY ANALYSIS, THE

Freud wrote *The Question of Lay Analysis* as an occasional piece in support of one of his friends, Theodor Reik, who had been accused of practicing medicine

illegally (he was not a physician). He cast it in the form of an informal conversation with an “impartial interlocutor,” probably Julius Tandler, the Viennese city councilor for welfare, with whom he had in fact discussed the Reik case.

The question of “lay” analysis had been of concern to Freud and his students for a long time because not all of them were physicians. The gap had progressively widened between those who, like Freud, felt that sound training as an analyst was all that mattered, regardless of any previously acquired diplomas, and those (particularly Abraham A. Brill and the Americans) who, considering analysis to be a medical discipline, wanted to prohibit non-physicians from practicing. Ernest Jones launched a major survey of the analytic community before the Innsbruck International Congress in September 1927, at which twenty-eight contributions on the subject were discussed without any agreement being reached. Freud wrote a “Postscript” for the occasion, maintaining his claim that analysis could be practiced by non-physicians.

Freud opens the imaginary conversation of *The Question of Lay Analysis* by describing disorders for which the ordinary physician can offer no real help, then proceeds to outline the methods of free association, dream analysis and so on, which seek to shed light on unconscious processes. He provides his putative interlocutor, whose supposed criticisms and questions frequently punctuate the exchange, with some notion, from the dynamic point of view, of his structural theory of the mind, of the instincts and, from the economic point of view, of repression and anxiety, of childhood sexuality, of the Oedipus complex, and so on. This metapsychological overview is followed by an account of the procedures of analytic therapy (transference, resistance, and the art of interpretation). Neither general medicine nor psychiatry prepares the physician for any of this, Freud declares; they may even constitute an obstacle. Special training is required, beginning with a personal analysis, without which even a physician may be no more than a quack. Any legislation on the subject would therefore be more of a hindrance than a help. Freud therefore concludes that analysis may perfectly well be practiced by non-physicians. Such an analyst would nevertheless need the help of a physician, prior to the analysis, in order to settle diagnostic questions or, in the course of the analysis, to take over in the case of disorders beyond the scope of the analyst: but the same holds for the

physician analyst. Freud concludes by tracing the program of what the ideal analytical training might involve (p. 246).

This work has had considerable influence on the debates that continue to this day on the “question of lay analysis” and the training of analysts. On the whole—though with noticeable variations from country to country—the International Psychoanalytical Association has adopted Freud’s position.

ROGER PERRON

*See also:* Lay analysis; Reik, Theodor; “‘Wild’ Psycho-Analysis.”

### Source Citation

Freud, Sigmund. (1926e). *Die Frage der Laienanalyse. Unterredungen mit einem Unparteiischen*. Leipzig-Vienna-Zurich, Internationaler Psychoanalytischer Verlag; GW, 14: 207–286; The question of lay analysis. *SE*, 20: 177–250.

———. (1927a). Nachwort zur Frage der Laienanalyse (1926e). *Internationale Zeitschrift für Psychoanalyse*, 13: 326–332; GW, 14: 287–296; Postscript: The question of lay analysis. *SE*, 20: 251–258.

### Bibliography

Jones, Ernest. (1959). *Free associations. Memories of a psychoanalyst*. London: Hogarth.

*Revue internationale d'histoire de la psychanalyse*. (1990). Histoire de l'exercice de l'analyse par les non-médecins, 3.

## QUOTA OF AFFECT

Affects are modes of expressing impulses, manifesting internal states of psychic life based on the two primitive polarities of pleasure and unpleasure, which play an essential role in the totality of mental functioning, especially in the defensive organization of the ego. The concept of affect can be found in the earliest examples of Freud’s psychoanalytic writings (1895d [1893–95]), where it is used to explain hysterical symptoms as a quantity of energy that cannot be discharged and, as a result, remains attached to memory. Therapy involves a recovery of this memory. Language, which is equivalent to the act, enables abreaction and the discharge of affect.

Originally, affect was considered by Freud to be a variable amount of excitation, a quantum of affect closely associated with memory traces. André Green

(1973) elucidated the concept when he spoke of the *ideational representative of the impulse* and its *affective-representative*. The idea of affect is also very close to the concept of libidinal energy; whenever the libido is repressed, it can be transformed into anxiety (the first Freudian theory of anxiety). This is perhaps the best-known example of affect.

In 1915 Freud wrote, “For this other element of the psychical representative the term *quota of affect* has been generally adopted. It corresponds to the instinct in so far as the latter has become detached from the idea and finds expression, proportionate to its quantity, in processes which are sensed as affects” (1915d, p. 152). Here, Freud seems to postulate that repression most deeply weighs upon the *ideational representatives*, which become unconscious, while affects are not found in the unconscious. They are excluded from consciousness through repression.

This vision of affects as charges capable of undergoing conversion (conversion hysteria), displacement (obsessional neurosis), transformation (anxiety neurosis), and being manifested through internal discharges that produce changes in the body of the individual, was substantially modified in Freud’s second theory of anxiety (1926d [1925]). Here, the ego becomes the seat of affects, especially anxiety. Anxiety automatically arises whenever the ego of the nursing child is overwhelmed by an instinctual excitation that it is unable to discharge on its own; gradually, the newborn realizes that the mother will help to dissipate this experience of danger. Subsequently, the ego experiences the loss of the mother as an alarm signaling the arrival of these dangers (signal anxiety). In this same work, Freud also describes other affects, such as psychic pain and sadness. Later, following the *Metapsychological Papers*, he emphasizes the importance of unconscious feelings of guilt that are part of the affects residing in the ego. These are complex affects that are made manifest through fantasies, such as those mentioned concerning the loss of the mother, in which “ideational representations” and affects are closely intertwined.

Melanie Klein (1948/1952) adhered to, and further developed, the Freudian concept of affects. Starting from annihilation anxiety, a primitive affect she conceived as the ego’s reaction to the internal threat caused by the death impulse, more complex affects associated with paranoid-schizoid and depressive positions came into being: persecution anxieties

and anxieties of depression, sadness, and guilt. Anxieties, therefore, become organized as a modality of fantasies that serve as prototypes of possible interactions of the ego with objects according to basic polarities: pleasure-unpleasure or annihilation experience-security experience. These help organize and determine the ego's relations with objects through mobilization of the various defense mechanisms that structure the mental life of the individual.

FRANCISCO PALACIO ESPASA

*See also:* Anxiety; Cathexis; Complex; Defense; Ego; Emotion; Excitation; I; Ideational representative; *Inhibition, Symptoms, and Anxiety*; Instinctual impulse; Instinctual representative; Memory; Music and psychoanalysis; Psychic representative; Quantitative/qualitative;

Representation of affect; Repression; Splitting; Suppression; Symptom; Turning around.

### **Bibliography**

Freud, Sigmund. (1915d). Repression. *SE*, 14: 141–158.

———. (1926d [1925]). Inhibitions, symptoms and anxiety. *SE*, 20: 77–175.

Freud, Sigmund, and Breuer, Josef. (1895d). Studies on hysteria. *SE*, 2: 48–106.

Green, André. (1973). *Le discours vivant: La conception psychanalytique de l'affect*. Paris: Presses Universitaires de France.

Klein, Melanie. (1952). Concerning the theory of anxiety and guilt. In M. Klein, P. Heimann, S. Isaacs, and J. Riviere (Eds.), *Developments in psychoanalysis*. London: Hogarth. (Original work published 1948)

# R B

## RACAMIER, PAUL-CLAUDE (1924–1996)

The French psychiatrist and psychoanalyst Paul-Claude Racamier was born on May 20, 1924, in Pont-de-Roide, and died on August 18, 1996, in Besançon.

The youngest of three brothers, Racamier had solid roots in his native Franche-Comté by way of his father, who came from a Catholic family in the Drôme and worked as an engineer at the Peugeot factory, and his mother, who came from a Protestant family in the Montbéliard region. Racamier's mother considered her son's health to be delicate and home-schooled him until the age of nine; this experience imparted a life-long stance marked by a passion for very individualistic ideas and a refusal of all conformism. After receiving a good secondary education in Montbéliard, he studied medicine in Besançon and then in Paris; he passed the medical exam qualifying him to practice in the psychiatric hospitals in 1952.

Racamier spent the first part of his career at the psychiatric hospital in Prémontre, where he worked from 1952 to 1962. Shocked by the dehumanizing conditions there, he established an improved setting for patients in his ward and gradually developed the therapeutic services of the institution itself. He then followed the same course of action in Switzerland, at the clinic of Rives de Prangins (1962–66), and subsequently at La Velotte, a treatment facility he created near Besançon in 1967, which would become his life's work. A limited number of patients (twelve at most), as many caregivers as patients, places for daytime activities and treatment, clearly separated from tastefully decorated and furnished, family-style living quarters, maintaining close contact with families, and so forth—such were the facility's prin-

ciples. They were based on Racamier's original theories.

These theories were nevertheless closely linked to Racamier's psychoanalytic training and activity. After undergoing analysis with Marc Schlumberger (and later with Evelyne Kestemberg), he worked with Sacha Nacht and Francis Pasche. He became a member of the Société psychanalytique de Paris (SPP; Paris Psychoanalytical Society) in 1958 and was elected to permanent membership in 1962. He taught at the University of Lausanne from 1962 to 1967, and then at the faculties of medicine and human sciences in Besançon. At the same time, he conducted many psychoanalytic and psychiatric training seminars; he served as director of the SPP's Institut de psychanalyse (Institute of Psychoanalysis) from 1975 to 1982.

Racamier's collaboration with colleagues who created and ran the mental health services of the 13th arrondissement in Paris (Philippe Paumelle, Serge Lebovici, René Diatkine, René Angelergues) led to a collectively authored book entitled *Le Psychoanalyste sans divan* (The psychoanalyst without a couch; 1970). In this book Racamier stressed an idea he would often return to: the need to simultaneously “care for” patients, caregivers, the group they form, the institution where they live, and families. The key word is to fight against the repetition compulsion that tends toward a routine where everything becomes fixed.

His theoretical writings originated in his practice working with adult psychoses: in *Les Schizophrènes* (Schizophrenics; 1980), he sought to show the “paradoxality” at work in these disorders. But his ideas went further. So did the ideas that came out of his work with patients suffering from postpartum psychoses.

Developing the notions of “mothering” and “motherhood,” he found close links between maternal psychosis and the child’s development; beyond this, he showed that in such situations, the entire process of “personation,” the sense of being an autonomous, coherent, and continuous person, is disturbed.

The same spirit of “going further” is evident in the notion of the *Antoedipus* (1989), a key element in Racamier’s thinking. In coining this term, Racamier intended to refer to both the “anti-oedipal” (that which is an obstacle to the oedipal organization) and the “ante-oedipal” (that to which the psyche is thus sent back); thus, in a “world of non-object objects,” the “anti-fantasy fantasies,” the “fantasies of self-procreation” that radically cancel out sexual and generational differences and the like, lead, according to the vicissitudes of this “shattered Antoedipus,” to psychosis or narcissistic perversions. However, the outcome of the Antoedipus is not necessarily so tragic: it remains present but discreet in the oedipal structures, contributing to their fluctuations and necessary reequilibrations.

This central notion is taken up anew in *Le Génie des origines: Psychoanalyse et psychoses* (The genius of origins: Psychoanalysis and psychoses; 1992), where Racamier articulated it, on one side, with the notion of primal mourning (renunciation of total possession of the object), and on the other, with a eulogy to ambiguity (to be distinguished from ambivalence), the condition for a psychic life that is sufficiently flexible, rich, and creative.

Racamier’s final work, *L’Inceste et l’incestuel* (Incest and the incestuous; 1995) returns to and broadens these ideas by going back to the very bases of his theorization, with the “incestuous,” that is, the totality of parent-child relations (particularly mother-child relations) that, by way of multiple substitutions, aim to maintain the eroticized narcissistic union of mutual seduction and block the oedipal organization.

Throughout, this succession of works shows the development and blossoming of a lively and original way of thinking that inevitably resonates with that of Donald W. Winnicott, Wilfred Bion, or even Jacques Lacan, even though Racamier, firmly anchored in his own practice, was not greatly concerned with backing it up with the theories of other authors. Racamier left behind a substantial life’s work, through his creation of institutions for the care of adult psycho-

tics and his practice there, through the theoretical contributions that were both the fruit of and the support for that practice, and, finally, through his teaching.

ROGER PERRON

*See also:* Ambivalence; Criminology and psychoanalysis; Delusion; Double bind; France; Incest; Infantile psychosis; Paradox; Parenthood; Postnatal/postpartum depression; Puerperal psychoses; Self-representation; Tenderness; Weaning.

### **Bibliography**

- Bayle, Gérard. (1997). *Paul-Claude Racamier*. Paris: Presses Universitaires de France.
- Racamier, Paul-Claude. (1980). *Les schizophrènes*. Paris: Payot.
- . (1989). *Antoedipe et ses destins*. Paris: Apsygée.
- . (1992). *Le Génie des origines: Psychoanalyse et psychoses*. Paris: Payot.
- . (1995). *L’Inceste et l’Incestuel*. Paris: Éditions du Collège de psychanalyse groupale et familiale.
- Racamier, Paul-Claude, et al. (1970). *Le Psychanalyste sans divan*. Paris: Payot.

---

## **RACISM, ANTI-SEMITISM, AND PSYCHOANALYSIS**

The word *race* is derived from the Italian *razza* (fifteenth century, “sort or species”); the concept of racism arose from the nineteenth-century development of anthropology and the life sciences, notably genetics. A naturalist, zoologizing scientific tendency led to the classification and hierarchical arrangement of human groups according to their specific history and their morphological, cultural, or psychological characteristics, which were deemed to be hereditary. Against this backdrop, an ideological application of the term *race* came to justify discrimination, segregation, exploitation, expulsions, and ultimately the twentieth century’s industrialization of mass murder and extermination camps.

Pierre-André Taguieff (1998) has pointed out that “protoracist” social phenomena grounded in xenophobia and ethnocentrism antedated the coining of

the word *racism*. He adduces three instances of such protoracism:

1. The myth of “pure blood,” in fourteenth-to-seventeenth-century Spain and Portugal, which underlay the statutes of 1449 (*estatutos de limpieza de sangre*) barring all honors, privileges, public positions, or employment to converted “new Christians” and their descendants; such Moors or Jews (in practice, mainly Jews) were decreed to be “unclean,” smirched (*maculados*), and carriers of foul infections.
2. The colonial slave system and the exploitation of “colored peoples”—black and Indian—in the West Indies and the Americas in the sixteenth and seventeenth centuries, which nourished fears of contamination associated with the color of the “skin” and “blood.”
3. The French aristocratic doctrine of an antagonism between “two races”: nobles with “clear and pure” blood and “commoners” whose blood was “vile and abject.”

The “purity of the blood” and its corollary, the shame associated with contamination, which was feared to bring about a transmissible degradation or degeneration, gave rise to a phobia of interbreeding, of any mixing of races or misalliance with respect to lineage. The groundwork of racism was thus laid before any of the modern taxonomies of race appeared.

The distinction between humans and “subhumans” gives rise to feelings of fear, hatred, and rejection, to fantasies of dangerousness and absolute possession projected onto the “uncanny” stranger. The ideology of race purification is founded on such feelings. The associations of the defense mechanisms involved (purifying, purging, purifying, cleaning, disinfecting, and so on) reflect an underlying fantasy of absolute autonomy that embodies violent ideas and hostility toward structures of kinship.

The ideology of racism had its master thinkers. In France, Arthur de Gobineau, in *The Inequality of Human Races* (1853–55), distinguished three main races: the black, the yellow, and the white. He extolled “race consciousness” and, thanks to Richard Wagner among others, found a growing audience in Germany. Georges Vacher de Lapouge’s *L’Aryen, son rôle social* (The Aryan and his role in society; 1889–90) subdivided the white race into the superior “dolichocephalic” Aryans and the inferior “brachycephalic” variety,

which included Jews. Spurred on by the Dreyfus Case, Édouard Drumont, in his *La France juive* (Jewish France; 1886), held the Jews to account for the “devastating calamities” of socialism, internationalism, and nihilism. Richard Wagner’s son-in-law, Houston Stewart Chamberlain, whose *Foundations of the Nineteenth Century* (1899) was to bring grist to the mill of the Nazis, further exacerbated the rift between Germans and Jews by taxing the latter with the notorious blood libel: *die Blutschande*, literally “blood shame”—a charge ideally designed to project onto the Jews a perverse fantasy of transgression of the prohibition against incest. And in 1895 Alfred Ploëtz brought in the expression “racial hygiene,” echoed later in the German *Rassenhygien*. So many words bear witness to the eugenic obsession that underpins all xenophobic and racist thinking.

*Anti-Semitism* itself is a word that was coined in Germany by Wilhelm Marr, founder of the Antisemitic League, in a pamphlet on “the victory of Judaism over Germanism” (1879).

The bloody tradition of anti-Jewish sentiment comes all the way from the ancient world down to what Roberto Finzi (1997/1998) has called the “tragic epilogue of the Shoah.” (*Shoah* is Hebrew for “catastrophe,” and denotes the Nazi genocide of the Jews; the term *genocide* was for its part introduced by Raphaël Lemkin in 1944 in his *Axis Rule in Occupied Europe*.)

On the ever-fecund dunghill of anti-Jewish stereotypes bequeathed by the collective imaginings of medieval Christianity, which deemed “the Jew” a “deicide” and a perfidious contemner of the word of Christ the Savior, the Jews of Central Europe were subjected to senseless demonization and accused of the “ritual murder” of children during Passover. Forced to live in restricted areas under discriminatory laws, they were the frequent victims of boycotts and pogroms (a Russian word meaning destruction)—explosive and bloody outbursts reflecting the envious and fearful animosity that they aroused. The culture of antisemitism, whose denunciations of the supposed “Jewish race” sometimes had a left-wing tinge to them (as witness, in France, Pierre-Joseph Proudhon, Charles Fourier, and Alphonse Toussenel—who inspired Drumont—or, in Germany, Werner Sombart), was buttressed by an “economic” dimension which threw suspicion on the Jews as putative promoters and developers of the capitalist system. This calumny



reached its acme in 1920 with the legend of a worldwide Jewish-Masonic conspiracy founded on the spurious *Protocols of the Elders of Zion* (1894–1905), forged by the Czar's secret police.

National Socialism carried anti-Semitism to its apotheosis. As dictator of the Third Reich, Hitler reintroduced the medieval ghetto and, taking his cue from the massacre of the Armenians in 1915, planned the genocide of the Jews (the idea was broached by him as early as 1925, in *Mein Kampf*), to whom he later added Gypsies and homosexuals. Germany, for Hitler, had to become *judenfrei* ("Jew-free") and *judenrein* ("cleansed of Jews"). This will to genocide was enshrined as a doctrine of state in the Nuremberg laws (1935), later imitated in Italy (1938) and in Vichy France's Jewish statutes of 1940–41. After World War II, new legal concepts became indispensable in order to conduct the Nuremberg Trials (1945–46), among them "crimes against humanity," "crimes against peace," and "war crimes."

Racism and genocide cannot help but oblige us to consider the epistemological underpinnings of an obsession with eugenics: genesis, gene, generation, genealogy, genus engendering eugenics, genocide.

From the Freudian perspective, the differences between human beings, between the sexes, and between generations, lying as they do at the heart of the hominizing process, lie in the development and sublimation of murderous, parricidal, and incestuous wishes, and hence too the structuring recognition of heredity, otherness and civilization.

Beginning in 1912, with *Totem and Taboo* and his formulation of the myth of the murder of the primal father, as well as with the watershed or pivotal work that underlay "On Narcissism" (1914c), Freud broadened his thinking from the field of the individual to that of humanity in a collective sense. He was especially interested, against the background of World War I, in the narcissistic stakes in play for the libido and for power in mass-psychological phenomena, as he was, too, in the relationship to death. These concerns were evident in "Thoughts for the Times on War and Death" (1915b), *Group Psychology and the Analysis of the Ego* (1921c), and *Civilization and Its Discontents* (1930a [1929]). Meanwhile, he pursued his reflections on the function of the individual psyche, and almost simultaneously, he produced works raising questions about the enigma of the "Uncanny" (1919h)

and about the repetition compulsion and the death instinct (*Beyond the Pleasure Principle* [1920g]). The attention Freud paid to the "uncanny" stranger who is at the same time "secretly familiar," and who may in fact be understood as an "internal enemy," was in fact the core of his thinking about racism and anti-Semitism.

In *Moses and Monotheism* (1939a [1934–38]), Freud stressed the part played by the Oedipus complex in Judaism, "a religion of the father," as in Christianity, "a religion of the son" (p. 88). He brought up the issue of circumcision, suggested that the claim of the Jews to be the chosen people was a cause of jealousy, and evoked the "narcissism of minor differences," which, by exaggerating the sense of belonging, constituted an obstacle to the effective sublimation of the instincts, to the formalizing role of the superego, to the greater sense of sanctity vouchsafed by monotheism and ethics.

Rudolph Loewenstein dedicated his *Christians and Jews: A Psychoanalytical Study* (1952) to Christians who sacrificed themselves for persecuted Jews. In his view Judeophobia was a form of demonophobia, and as such an incurable "hereditary psychosis" that had existed since antiquity. The "Nazi religion," which preached the supremacy of the Aryan race, exalting earth and blood, the primacy of force over right, and the revolt of the instincts against the universal value of the superego, was certainly anti-Jew, but it was also anti-Christian.

According to Imre Hermann (1945), anti-Semitism is a collective sickness that is endemic as well as epidemic in nature. In Hermann's theory of attachment, the "clinging instinct," coupled with the instinct for knowledge, was the foundation of the mother/infant dual unity. Basing himself on the "clinging instinct/dermic system" combination, which he saw as the beginning of social contact, he saw the unconscious roots of the Nazi thesis that equated non-Aryans, and especially Jews, to vermin, germs or vampires in a specific kind of cathexis of the "skin" of the social body. The pleasure obtained by masses of people clinging in regressive fashion to a gigantic nourishing mother would account, in Imre's view, for the fascination with a leader who promised the "miraculous" destruction of the people that invented monotheism.

Drawing on his biopsychic and prenatal theory of narcissism, Bela Grunberger (1997) has described

specifically Christian anti-Semitism as a grandiose narcissistic aspiration to purity, as the rejection of an anality unintegrated into the self and its projection onto Judaism, which, being an authentic moral system underpinned by the oedipal paternal principle, has done away with the narcissistic maternal principle.

“Desolation,” a major concept in Hannah Arendt’s reflection on the origins of totalitarianism, may be said to correspond, on the level of political philosophy, to what Freud, in *Inhibitions, Symptoms and Anxiety* (1926d) and *The Future of an Illusion* (1927c), and other psychoanalysts after him, referred to as “*Hilflosigkeit*,” meaning a state of helplessness (that of the human infant). The view that heredity informs totalitarian racism in general and the genocide of the Jews in particular implies a systematic attack on the links of kinship and marriage and tends towards the structural actualization of what Pierre Legendre (1989) has called a “slaughter-house theory of heritage.”

The psychoanalytical reflections of Janine Altounian and H el ene Piralian on the Armenian “catastrophe” or those of Jacques Ascher on the “extermination of extermination” likewise testify to the gravity of the injuries sustained. The genocide carried out by the Nazis was the outcome of a “culture of extermination” (Gillibert and Wilgowicz). This pure culture of the death instinct, characterized by collective phenomena of adherence to a leader who has replaced the ideal ego, is constitutive of what Wilgowicz has described as a “historic mass vampirism” founded on infanticide and matricide/parenticide and on a disavowal of both birth and death, which destroys the narcissistic bases of identity in the survivors. As of 2005, three generations after the Shoah, the repercussions were still being felt.

JACQUES ASCHER AND PEREL WILGOWICZ

*See also:* Austria; Chertok, L eon; *Christians and Jews: A Psychoanalytical Study*; Fanon, Frantz; France; Germany; Hermann, Imre; Judaism and psychoanalysis; Langer, Marie Glass Hauser de; *Moses and Monotheism*; Narcissism of minor differences; Politics and psychoanalysis.

### **Bibliography**

- Arendt, Hannah. (1951). *The origins of totalitarianism*. New York: Harcourt, Brace & World.
- Finzi, Roberto. (1998). *Anti-semitism* (Maud Jackson, Trans.). New York: Interlink. (Original work published 1997)

- Freud, Sigmund. (1912–13a). Totem and taboo. *SE*, 13: 1–161.
- . (1914c). On narcissism: An introduction. *SE*, 14: 67–102.
- . (1915b). Thoughts for the times on war and death. *SE*, 14: 273–300.
- . (1919h). The “uncanny.” *SE*, 17: 217–256.
- . (1920g). Beyond the pleasure principle. *SE*, 18: 1–64.
- . (1921c). Group psychology and the analysis of the ego. *SE*, 18: 65–143.
- . (1926d [1925]). Inhibitions, symptoms and anxiety. *SE*, 20: 75–172.
- . (1927c). The future of an illusion. *SE*, 21: 1–56.
- . (1930a [1929]). Civilization and its discontents. *SE*, 21: 57–145.
- . (1939a [1934–38]). Moses and monotheism. *SE*, 23: 1–137.
- Gillibert, Jean, and Wilgowicz, Perel (Eds.). (1993). *L’Ange exterminateur* (Proceedings of the Colloque de Cerisy). Brussels:  ditions Universitaires de Bruxelles.
- Grunberger, Bela, and Desuant, Pierre. (1997). *Narcissisme, christianisme, antis mitisme*. Paris: Actes Sud.
- Hermann, Imre. (1945). *Az Antiscemizmus*. Budapest: Bibliotheca.
- Legendre, Pierre. (1989). *Le Crime du caporal Lortie, trait  sur le p re*. Paris: Fayard.
- Loewenstein, Rudolph M. (1952). *Christians and Jews: A psychoanalytical study*. New York: International Universities Press.
- Taguieff, Pierre-Andr . (1998). *La couleur et le sang*. Paris: Mille et Une Nuits.

---

### **RACKER, HEINRICH (1910–1961)**

Heinrich Racker, a doctor of philosophy, was born in Poland in 1910 and died in Buenos Aires on January 28, 1961.

When World War I broke out his family sought refuge in Vienna. In the course of his youth he acquired a solid grounding in general culture: He took an interest in literature, discovered psychoanalysis, and became an excellent pianist. In 1935 he obtained a doctorate in philosophy and one year later he was

admitted to the Vienna Institute of Psychoanalysis, where he was analyzed by Jeanne Lampl-de Groot. In 1937 he enrolled as a medical student. One year later the Anschluss took place.

Racker fled from Vienna, finally emigrating to Buenos Aires in 1939 after many vicissitudes. In spite of his financial difficulties he commenced analysis with Ángel Garma, who generously received him. He later did his training analysis with Marie Langer and in 1946 he completed his training in the Argentine Psychoanalytic Association (APA). In 1947 he became a subscribing member of the Association and a full member in 1950, becoming a training analyst one year later.

Racker was very young when he presented his first work on countertransference, a subject that was to confirm his reputation as one of the most original analysts in the history of the discipline. Presented at an APA conference in September 1948, “La neurosis de contratransferencia” (The countertransference neurosis) made a very strong impression. In this paper, which was not published for another five years, Racker emphasized the dialectical relation that exists between the transference and the countertransference. He revolted against the myth of the impersonal analyst and pointed out that countertransference reactions can give the analyst an indication of what is happening for the analysand. This was the essential point in the new theory of the countertransference that came into being in the middle of the twentieth century.

Simultaneously, at the sixteenth International Congress (Zurich, 1949) Paula Heimann presented her study *On Countertransference*, which was published in 1950. Without any consultation between them, Racker and Heimann had reached the same conclusions. But, as Cesio (1961) pointed out, whereas Racker developed the subject without delay and succeeded in interesting the scientific community, it took Heimann ten years to reconsider the question and her work had only a small impact.

In the 1950s Racker produced fundamental work. “Observaciones sobre la contratransferencia como instrumento técnico” (Observations on the countertransference as a technical instrument), presented to a conference in 1951 and published one year later, and “Los significados y usos de la contratransferencia” (Meanings and uses of the countertransference), in 1953, published in the *Psychoanalytic Quarterly* in 1957.

Apart from his studies of the countertransference, Racker wrote essays on music, art, and literature, which were published in book form in 1957. Psycho-pathological stratification was another of his interests, on which he published an article in the same year.

Although his publications and his work as an analyst and teacher were the most remarkable aspects of his activity, Racker also shone through his participation in the life of the Argentinean Association. With the publication of his work on psychoanalytic technique, Racker was appointed Sloan Visiting Professor at the Menninger School of Psychiatry, as well as being made a member of the symposium “The factors of healing in psychoanalysis” at the Edinburgh International Congress in 1961. Death did not leave him the time to complete these tasks. But in November 1960 he gave a conference entitled “Psychoanalysis and Ethics,” which was published 1966, after his death. It was the crowning glory of a noble life and a message of love for science, psychoanalysis, and humanity. He died in 1961, aged fifty, at the height of his creativity.

R. HORACIO ETCHEGOYEN

See also: Argentina; Change; Empathy.

### Bibliography

- Racker, Heinrich. (1951). Observaciones sobre la contratransferencia como instrumento técnico. *Revista de psicoanálisis de la Asociación psicoanalítica argentina*.
- . (1953). A contribution to the problem of countertransference. *International Journal of Psycho-Analysis*, 34 (4), 313–324.
- . (1957). The meanings and uses of countertransference. *Psychoanalytic Quarterly*, 26 (3), 303–357.
- . (1957). *Psicoanálisis del espíritu*. Buenos Aires: Nova. A.P.A.
- . (1968). *Transference and countertransference*. New York: International Universities Press. (Original work published 1960)

---

## RADÓ, SÁNDOR (1890–1972)

Sándor Radó, a Hungarian psychoanalyst and physician, was born in 1890 in Kisvarda, Hungary, and died on May 14, 1972, in New York City. Radó grew up in a middle-class business family 100 miles from Budapest. He studied at the Universities of Berlin, Bonn, and

Vienna, completing a political science degree in Budapest in 1911. He then enrolled in medical school in Budapest.

In 1913, Radó became, with four others, one of the founding members of the Hungarian Psychoanalytic Society. He first met Freud before World War I, due to an introduction from Radó's mentor, Sándor Ferenczi. In 1924, when Radó was already prominent in Berlin, Freud chose him to replace Otto Rank as editor-in-chief of the most important analytic journal, the *Zeitschrift*. Radó was known as an outstanding theoretician, and in Europe analyzed people of the stature of Wilhelm Reich, Heinz Hartmann, and Otto Fenichel.

When the New York Psychoanalytic Society was establishing its first Training Institute in 1931, Radó was invited to be the founding director. In 1935 difficulties arose between himself and Freud. The Viennese analysts around Freud were a palace guard of advisors who long envied Radó's special position. Freud resented the way Radó had been helping analysts to leave the continent for the United States. Radó had opposed Freud's plan to build a new international institute in Vienna after Hitler came to power.

The crisis between Freud and Radó in 1935 was occasioned by a critical review of one of the Radó's monographs written by Jeanne Lampl-de Groot, then a current patient of Freud's. The review appeared to be published with Freud's tacit endorsement. Then, shortly after Karen Horney had been demoted by the education committee of the New York Psychoanalytic Society, Radó was deposed as educational director.

In 1944, just as Radó was to found the Psychoanalytic Clinic at Columbia University's medical school, he was thrown out of the New York Psychoanalytic Institute as a training analyst. Even before then he was viewed as a traitor. Unlike other so-called dissidents within Freud's movement, who chose to make their appeal to the general reading public, Radó wanted to go deeper into university medicine.

Radó had been from the outset of his career in Berlin especially concerned with establishing standards of education and training. Some of his papers from those years, on melancholia and drug addiction for example, continue to seem outstanding. As time went on Radó, like other rebels in analysis, worked out new terms for old concepts. For some years he was a member of the New York State Mental Hygiene Council, and both

Governors Averell Harriman and Nelson Rockefeller supported his work with state grants. Radó retired from Columbia in 1955, after which he helped to create the New York School of Psychiatry at the State University of New York, where he was director for ten years.

Radó came to oppose the idea that the removal of repressions and the emergence of buried memories can necessarily be expected to have good therapeutic effects. Also, he thought that the provoking of transferences was a clinical mistake, since regression undermined a patient's capacity for autonomy and self-reliance. In addition, Radó was prescient enough to have emphasized the significance of genetics for the future of psychoanalytic psychiatry.

Radó was a sophisticated European man of letters, who belongs to the radical left within the history of analysis; but it has remained a fragmented tradition of so-called dissenters. Although Radó was for a time allied with New York's Abram Kardiner, and Radó's work on therapy was similar to the ideas of his fellow Hungarian Franz Alexander, these critics of the "mainstream" in analysis have rarely hung together. None of them would have dreamed of citing approvingly such earlier "heretics" as Carl Jung, Alfred Adler, or Rank. The nonconformists have been the ones with the original ideas, even though their position has so far won them inadequate recognition. It is hard to become educated in the real story of analysis because of the sectarianism that has afflicted the movement. As of 2005, some of the most persuasive present-day critics of Freud are only now reinventing concepts that were first advanced many years ago.

Radó's later writings can be hard to follow. He disdained popularizations and put his faith in medical science. Like Freud himself, Radó was a spell-binder who spoke like a book. Yet Radó underestimated Freud's contribution to the humanities, and was intolerant of the significance of analysis for philosophy and the social sciences. Within psychiatry itself, though, Radó may well turn out to have been prophetic.

PAUL ROAZEN

*See also:* Addiction; Alcoholism; Germany; American Academy of Psychoanalysis; Bulimia; Dipsomania; Hungarian School; Hungary; *Internationale Zeitschrift für (ärztliche) Psychoanalyse*; Melancholic depression; New York Psychoanalytic Institute; United States.

### **Bibliography**

Radó, Sándor. (1956–62). *Psychoanalysis of Behavior*, Vols. 1 and 3. New York: Grune & Stratton.

———. (1969). *Adaptational Psychodynamics*. (Jean Jameson and Henriette Klein, Eds.). New York: Science House.

Roazen, Paul, and Swerdloff, Bluma. (1995). *Heresy: Sándor Radó and the Psychoanalytic Movement*. New Jersey: Aronson.

---

## **RAIMBAULT, ÉMILE (1923–1998)**

Émile Raimbault, a French physician, psychologist, psychoanalyst, and member of the École Freudienne de Paris, was born in Anjou on October 21, 1923, and died at Saumur on August 21, 1998.

He first studied psychology, then, on the advice of Jacques Lacan, with whom he commenced his psychoanalysis, he also began to study medicine. He followed Lacan into the Société française de psychanalyse on the occasion of the split in 1953. Michael Balint, the first guest of this society, encouraged him and his wife, Ginette Raimbault, to regularly attend the “training cum research” seminars (“training seminars for physicians on the therapeutic relationship”) that he gave at the Tavistock Clinic in London under the auspices of the National Health Service. The Balint and Raimbault families became close friends.

Along with his wife and Jacques Gendrot, Émile Raimbault soon started one of the first “Balint groups” in France. This mixed group (physicians, interns, physiotherapists, an odontologist, and trainee psychoanalysts) met in the Raimbaults’ home in Paris. Known by the name of their street, the “Marignan group” became a reference for those that followed.

Raimbault also practiced as an analyst under Raoul Kourilsky in the Saint-Antoine hospital, where the pneumologist began to experiment in 1949 with a new type of consultation conducted by a “therapeutic pair”: an organicist physician and an analyst. Raimbault then introduced, in addition to listening to the patient’s unconscious, listening to the suffering of the medical team treating dying patients: he created the first Balint group in the hospital department. His experience resulted in his being appointed director of the psycho-oncology team in the Institut Gustave-Roussy, a position he occupied for fifteen years.

Along with Raoul Kourilsky and Jacques Gendrot, Raimbault co-edited the proceedings of the first congress in France, after the Brighton congress, of Balint leaders, held in the Paris medical faculty in 1964 and at the Trianon in Versailles. He was also responsible for a report on the leaders’ meeting, published in the same volume. He also wrote an essay on death with the title *La Délivrance*.

MICHELLE MOREAU RICAUD

*See also:* Balint group.

### **Bibliography**

Raimbault, Émile, et al. (1964). *La Formation psychologique des médecins*. Paris: Maloine.

———. (1976). *La Délivrance*. Paris: Mercure de France.

---

## **RAMBERT, MADELEINE (1900–1979)**

Madeleine Rambert, a Swiss psychoanalyst, was born in 1900 in Lausanne, where she died on May 17, 1979. The daughter of a pastor in the Free Evangelical Church of Vaud, she trained to be a teacher and soon specialized in handling backward children. She opened a facility for such children in Croix-sur-Romainmôtier. To improve her training she moved the facility to Lausanne and enrolled in classes at the Institut Jean-Jacques-Rousseau, where she studied psychoanalysis.

She was psychoanalyzed by Raymond Saussure and, after being supervised by Philipp Sarasin in Basel, she began practicing child psychoanalysis and became a member of the Société Suisse de Psychanalyse (Swiss Psychoanalytic Society) in 1942. That same year, Lucien Bovet founded the Office Médico-Pédagogique (Medical Training Center) in Vaud. Rambert worked at the Center, training the doctors and psychologists who came to practice there.

She is best known for her use of puppet therapy. She published a description of the technique in 1938, and again in 1945 in *Children in Conflict, Twelve Years of Psychoanalytic Practice*, which included a preface by Jean Piaget. The book became an international success. Observation of the child at play led to the identification and interpretation of standard behaviors, which the game triggered. Rambert was closely associated with the Vienna school and described three phases in

the treatment of the child: exteriorization of conflict; conscious realization and elimination of the neurotic conflict; and re-education.

During the 1960s and 1970s, she continued her training activities with teachers at the Pestalozzi School (Switzerland) and worked with delinquent women. In this way she was able to perpetuate her educational and social work, which characterize her role as one of the first clinicians in the field of child psychoanalysis in Switzerland.

ALAIN DE MIJOLLA

*See also:* Switzerland (French-speaking).

### **Bibliography**

Rambert, Madeleine. (1938). Une nouvelle technique en psychanalyse infantile: le jeu de guignols. *Revue française de psychanalyse*, 10, 1.

———. (1945). *Children in conflict, twelve years of psychoanalytic practice* (Yvette Moxley, Trans.). New York: International Universities Press.

Roch, Marcel (1979). Mademoiselle Madeleine Rambert (1900–1979). *Bulletin de la Société suisse de psychanalyse*, 9, 21–22.

---

## **RANK-MINZER (MUNZER), BEATA (1886–1961)**

Psychoanalyst Beata Rank was born on February 16, 1886, in Neusandetz near Krakow, Poland, then part of the Austrian-Hungarian Empire. She died on April 11, 1961, in Boston. Her life can be divided into four distinctive periods in different countries, which in turn delineated her professional career.

Originally named Beata Minzer (or Munzer), she was born into a middle-class, assimilated Jewish family. Early on she chose for herself the name Tola, used by family and friends, but never professionally. Her mother was one of 12 children, several of whom became professionals or business people. Beata's interest in psychology and the arts was encouraged by an aunt who had studied in Vienna and is credited with introducing her to her future husband, Otto Rank. Otto had been drafted into the army and stationed in Krakow where he was the editor of the *Krakauer Zeitung* from 1916 to 1918. Beata and Otto were married in a Jewish ceremony on

November 7, 1918, a week before the armistice. The young couple moved back to Vienna soon thereafter.

Vienna, 1918–1926: This period covers the last years of the Rank-Freud relationship, culminating with the well-documented, yet still not completely understood, final break. Beata and Otto's only child, Helene, was born on August 23, 1919. With Freud's and her husband's encouragement, Beata attended meetings, seminars, and lectures on psychoanalysis. She worked with Otto in the Verlag. Her interest in dream work led to her translation into Polish in 1923 of Freud's book *Über Träume* (*On Dreams*), and a later inquiry into the dreams of six-year-old schoolchildren. Also in 1923 she presented a paper to the Vienna Psychoanalytical Society which served as her ticket of admission to the group. It appeared in *Imago* in 1924 in the original German. An English translation of the title would be "The role of woman in the development of human society." The *Imago* paper was meant as an introduction to a large three-part study on the subject, which was never completed.

Paris, 1926–1936: In 1924 Otto began visiting the United States, teaching, lecturing, and seeing patients. By 1926 the relationship with Freud had seriously deteriorated, and the Rank family moved to Paris. This was seen as a compromise since Beata did not want to move to the United States, while artistic and cultural Paris had great appeal. As for Otto, Paris was a rest stop. He would build an American practice and earn a good income while increasing his American visits. Beata did not engage in clinical work during her Paris years, but continued research at the Bibliothèque Nationale on the role of women. In 1933, Otto, with the encouragement of some American colleagues, developed the Psychological Center and Summer Institute, a training, teaching, and general education center, and Beata worked with him primarily as an administrator. In 1934 there was a "de facto" dissolution of their marriage when Otto emigrated to the United States. This was also the time when he and Anaïs Nin became involved. Beata remained in Paris while their daughter Helene completed her French baccalaureate. Then, with Fascism extending its power, she decided to leave.

Boston, 1936–1969: Beata, still legally married to Otto, was able to enter the United States with Helene in the fall of 1936 as permanent residents under Otto's visa. Beata came to Boston where she was quickly accepted in the Boston psychoanalytic community,

due especially to the help of her longtime close friends from Vienna, Helene and Felix Deutsch. She came into her own as a prominent child analyst, as well as a highly respected supervisor and training analyst at the Boston Psychoanalytic Institute, where she was chair of the education committee for several years. Her influence reached far in the Boston community as diverse mental health professionals, as well as pediatricians and social scientists, sought out her teaching, while psychiatrists from many other countries also came to study with her. She was an honorary Professor of Psychiatry at Boston University School of Medicine, a consultant and supervisor at Judge Baker Guidance Center, and with Marian C. Putnam, co-founded and co-directed the James Jackson Putnam Children's Center in 1943. This center was a pioneering day-treatment facility for pre-school children and their parents. It simultaneously offered day-care and/or psychological evaluation and treatment for children with emotional and cognitive developmental problems, and their parents. Research was an integral part of the program and the staff published numerous papers, including Beata Rank's papers on atypical development. Beata Rank's contributions to child analysis live on through the many people she influenced through her teachings.

HELENE RANK-VELTFORT

See also: Rank (Rosenfeld), Otto.

### **Bibliography**

- Lieberman, E. James. (1985). *Acts of will: The life and work of Otto Rank*. New York: The Free Press.
- Rank, Beata. (1924). Zur Rolle der Frau in der Entwicklung der menschlichen Gesellschaft (On the role of the woman in the development of human society). *Imago*, 10, 1924, 278–295; Abstract in *International Journal of Psycho-Analysis*, 7, 1926, 89.
- . (1942). Where child analysis stands today. *American Imago*, 3 (3), 41–60.
- . (1949). Adaptation of the psychoanalytic technique for the treatment of young children with atypical development. *American Journal of Orthopsychiatry*, 19, 130–139.
- . (1955). Intensive study and treatment of pre-school children who show marked personality deviations, or atypical development and their parents. In G. Caplan (Ed.), *Emotional problems of early childhood: Proceedings of the International Institute of Child Psychiatry* (pp. 491–501). New York: Basic.

## **RANK (ROSENFELD), OTTO (1884–1939)**

Otto Rosenfeld Rank, an Austrian psychologist and psychoanalyst, was born on April, 22, 1884, in Vienna and died on October 31, 1939, in New York.

He was the son of Simon Rosenfeld, an artisan jeweler, and Karoline Fleischner. His older brother studied law while Otto became a locksmith: the family could not afford higher education for both. Close to his mother but alienated from his alcoholic father, Otto adopted the name “Rank” in adolescence and formalized it a few years later, symbolizing self-creation, a central theme of his life and work.

Of Jewish background, growing up in Catholic Vienna, Rank was a religious skeptic who wrote his own Ten Commandments, among them “Thou shalt not give birth reluctantly.” He read deeply in philosophy and literature, loved music, and considered himself an artist, writing poetry and a literary diary. Before he was 21, he read Freud's *Interpretation of Dreams* (1900). He applied psychoanalytic ideas in an essay on the artist; the manuscript came to Freud (probably through Alfred Adler, Rank's physician) which led to Rank's appointment as secretary of the Vienna Psychoanalytic Society in 1906. With Freud's financial and moral support, Rank obtained his PhD from the University of Vienna in 1912, the first candidate to do so with a psychoanalytic thesis subject.

Rank became the acknowledged expert on philosophy, literature, and myth in the Vienna Psychoanalytic Society and kept the minutes (1906–1918; later published in four volumes). He became the most prolific psychoanalytic writer after Freud, with *Der Künstler* (1907; expanded editions 1918 and 1925), *Der Mythos der Geburt des Helden* (1909), *Die Lohengrin Sage* [his doctoral thesis] (1911), and *Das Inzest-Motiv in Dichtung und Sage* (1912, 2nd edition 1926), a 700-page survey of world literature. Except for the posthumous *Beyond Psychology* (1941), Rank's books were written in his native German. Translations, mostly of his early psychoanalytic works, exist in English, French, Italian, and Spanish.

Other works important in Rank's Freudian period include “Ein Beitrag zum Narcissismus” (*Jarbuch*, 1911), *Die Bedeutung der Psychoanalyse für die Geisteswissenschaften* (1912, with H. Sachs), *Psychoanalytische Beiträge zur Mythenforschung* (1919), *Die Don Juan Gestalt* (1922), *Der Doppelgänger* (1925), *Eine Neurosenanalyse in Traumen* (1924), *Sexualität und Schuldgefühl*

(1926), *Technik der Psychoanalyse* (I. *Die Analytische Situation*, 1926; II. *Die Analytische Reaktion*, 1929; III. *Die Analyse Des Analytikers*, 1931; II and III translated as *Will Therapy*, 1936), *Grundzüge einer genetischen Psychologie* (I. *Genetische Psychologie*, 1927, II. *Gestaltung und Ausdruck der Persönlichkeit*, 1928; III. *Wahrheit und Wirklichkeit*, 1929, translated as *Truth and Reality*, 1936).

Rank was a member of Freud's Committee, or "Ring" of Seven and his closest associates (1906–1925). Of the founders of the International Psychoanalytical Association, Rank was closest to Freud geographically, professionally, and personally. He helped edit and contributed two chapters to Freud's *Die Traumdeutung* (editions 4–7, 1914–1922; "Traum und Dichtung" and "Traum und Mythos"). He and Hanns Sachs edited the journal *Imago*, beginning in 1912, with Freud and Sándor Ferenczi he edited *Die Zeitschrift für Psychoanalyse* beginning in 1913. Rank witnessed the vicissitudes and bitter endings of Freud's relationships with Wilhelm Stekel, Alfred Adler, and Carl Jung; Rank's tenure with Freud lasted much longer—two decades, exceeded only by that of his friend Sándor Ferenczi and his foe Ernest Jones.

Freud, who had discouraged young Rank from pursuing a medical career, after 1912 always addressed him as "Dr. Rank" and referred patients to him. This was consistent with his support of non-medical or "lay" analysis. Freud and Rank agreed on another controversial issue: the eligibility of homosexual candidates for analytic training.

Rank served in the Austrian army in Poland during World War I, where he met and married Beata "Tola" Mincer in 1918; she became a noted lay analyst and practiced in Boston after their separation in 1934. The birth of their only child, Helene (1919), enhanced Rank's interest in the pre-oedipal phase of development (birth to age 3) and the mother-child relationship.

He was co-founder of the International Psychoanalytical Association in 1910, honorary member of the American Psychoanalytic Association (1924–1930). Freud and Rank established the Internationaler Psychoanalytischer Verlag in 1919, which became Rank's major responsibility along with training psychoanalytic candidates from around the world. In 1924 Rank published *Das Trauma der Geburt*, emphasizing the importance of separation and individuation, with their attendant and inevitable anxiety in the pre-oedipal

period. Until then psychoanalysis had been father-centered, with oedipal conflict at the center. Rank meant only to balance and extend Freud's work but this book, and his work with Ferenczi on active therapy—*Entwicklungsziele der Psychoanalyse* (1924)—led to a final break with his mentor and virtual foster father. That same year Rank turned 40 and visited the United States for the first time. He was honored as Freud's emissary, although his ideas were beginning to challenge established Freudian doctrine.

Over the next decade Rank lectured, taught, wrote, and practiced a briefer form of psychoanalytic therapy with a more egalitarian relationship between therapist and patient. Rank modified the open-ended analytic process by using termination as the focus for separation and independent development. In this respect his work anticipated the innovations of Franz Alexander (brief analytic therapy, and the corrective emotional experience).

Orthodox Freudians condemned Rank as a deviant. The American Psychoanalytic Association expelled him and required his former analysands to undergo re-analysis. Although Rank suffered from poor physical health and occasional depression, assertions that his departure from the psychoanalytic fold were a result of mental instability (by Ernest Jones and A. A. Brill) are not supportable. The work of Rank and his colleague, Ferenczi, is being studied and discussed more objectively by psychoanalytic scholars in the twenty-first century.

Rank's creativity continued to flourish in his post-Freudian period. Between 1926 and 1931 he wrote major works on developmental psychology and therapeutic technique which are considered forerunners of object relations theory and ego psychology (Rudnytsky, 1991). He emphasized conscious experience, the present, choice, responsibility, and action, in contrast with the (classical Freudian) unconscious, past history, drives, determinism, and intellectual insight. *Seelenglaube und Psychologie* (1930) and *Art and Artist* (1932) are psychoanalytically informed major works of social psychology and cultural history addressing religion and creativity, respectively.

Rank's emphasis on will, relationship, and creativity appealed to psychologists Rollo May, Carl Rogers, Esther Menaker, Paul Goodman, and Henry Murray. Noted psychiatrists influenced by Rank include Frederick Allen, Marion Kenworthy, Robert Jay Lifton, Carl Whitaker, and Irvin Yalom; writers



and critics include Ernest Becker, Maxwell Geismar, Max Lerner, Ludwig Lewisohn, Anaïs Nin, Carl Rakosi, and Miriam Waddington.

Some of Rank's ideas which seemed radical in his time have become the mainstream of psychoanalytic thought: the importance of the early mother-child relationship; the ego, consciousness, the here-and-now, and the actual relationship—as opposed to transference—in therapy. He anticipated and influenced interpersonal, existential, client-centered, Gestalt, and relationship therapies. As a social psychologist he contributed to our understanding of myth, religion, art, education, ethics, and organizational behavior.

Rank's companion in the last four years of his life was Estelle Buel, an American of Swiss descent whom he married just three months before his death. He had applied for United States citizenship when a kidney infection led to fatal septicemia; he died in New York City at 55.

The Butler Library at Columbia University in New York holds the Otto Rank papers in its rare book and manuscript collections. *The Journal of the Otto Rank Association* appeared twice annually from 1966 to 1983, publishing works by Rank and many others who knew him or his writings. A collection of his American lectures (1924–1938) has been published as *A Psychology of Difference* (Robert Kramer, Ed., 1996).

E. JAMES LIEBERMAN

*Works discussed:* *Development of Psycho-Analysis*; *Don Juan* and *The Double*; *Myth of the Birth of the Hero*, *The Trauma of Birth*, *The*.

*See also:* Applied psychoanalysis and interactions of psychoanalysis; Birth; Castration complex; Double, the; First World War: The effect on the development of psychoanalysis; *Gesammelte Schriften*; *Imago*. *Zeitschrift für die Anwendung der Psychoanalyse auf die Geisteswissenschaften*; *Inhibitions, Symptoms, and Anxiety*; *Internationale Zeitschrift für (ärztliche) Psychoanalyse*; Internationaler Psychoanalytischer Verlag; "Lines of Advance in Psycho-Analytic Therapy"; *Minutes of the Vienna Psychoanalytic Society*; *Myth of the hero*; Narcissism; Narcissism, primary; Neutrality/benevolent neutrality; *New Introductory Lectures on Psycho-Analysis*; Nin, Anaïs; Secret Committee, the; Signal anxiety; Splits in psychoanalysis; Termination of treatment; Technique with adults, psychoanalytic; Training analysis; Visual arts and psychoanalysis; Wiener psychoanalytische Vereinigung.

### **Bibliography**

Menaker, Esther. (1982). *Otto Rank: A rediscovered legacy*. New York: Columbia University Press.

Rudnytsky, Peter. (1991). *The psychoanalytic vocation: The legacy of Otto Rank and Donald Winnicott*. New Haven, CT: Yale University Press.

Taft, Jessie. (1958). *Otto Rank*. New York: Julian.

Zottl, Anton. (1982). *Otto Rank: Das Lebenswerk eines Dissidenten der Psychoanalyse*. München, Germany: Kindler.

---

### **RAPAPORT, DAVID (1911–1960)**

David Rapaport, a Hungarian psychoanalyst with a PhD in philosophy, was born in Budapest on September 30, 1911, and died December 14, 1960, in Stockbridge, Massachusetts. Born into a middle-class Jewish family, he quickly became active in the Zionist movement and, after studying mathematics and physics at the university, spent two years in a kibbutz in Palestine. There he married Elvira Strasser; their first child, Hanna, was born shortly after. Upon returning to Hungary in 1935, he ran the Young Zionist movement and began studying psychoanalysis with a relative, Samuel Rapaport, about whom he wrote two books. He was analyzed by Theodor Rajka from 1935 to 1938, and obtained his doctorate in psychology at the Royal University of Hungary, Petrus-Pazmany, in 1938, with a dissertation on the history of the concept of association from Bacon to Kant.

In December 1938, with the help of the Emergency Committee on Relief and Immigration of the American Psychoanalytic Association, he and his family traveled to the United States. He worked in New York as a psychologist at Mount Sinai Hospital, then at Osawatomie State Hospital, Kansas, for a year. In 1940 he joined the Menninger Clinic, in Topeka, Kansas, where he became director of the School of Clinical Psychology, then head of the Research Department. His *Emotions and Psychology*, which appeared in 1942, is a record of his early research, as is *Diagnostic Psychological Testing* (1945–1946), published in collaboration with Roy Schafer and Merton Gill.

In both books Rapaport refers to the theories of ego-psychology. In August 1948 he left Topeka for the Austen Riggs Center in Stockbridge, Massachusetts, leaving behind his wife, a mathematician, and

his two daughters Hanna and Juliette (born in 1943). He worked at Austen Riggs until his death from a heart attack at the age of forty-nine.

Although he never worked as a psychoanalyst, Rapaport was interested in treating schizophrenics and borderline cases, and soon became an eminent theoretician of psychoanalysis. His classes and conferences on affects, activity-passivity, and memory, his comments on chapter 7 of Sigmund Freud's *The Interpretation of Dreams*, his translations of Otto Fenichel, Paul Schilder, and Heinz Hartmann, provided him with many students and material for several books, including *Organization and Pathology of Thought* (1951), and many articles, which were collected after his death and are often cited. A member of the Western New England Psychoanalytical Society, he was an at-large member of the International Psychoanalytical Association and, shortly before his death, in September 1960, received a prize from the American Psychological Association's division of clinical psychology.

His close collaborator Merton Gill said of Rapaport that "he spoke of metapsychological abstraction with the fervor of a political orator and the thunder of a Hebrew prophet." Gill also recalled Rapaport's desire to create a general psychology that would include ego psychology and social psychology while retaining Freud's revolutionary intuitions about the id.

ALAIN DE MIJOLLA

*See also:* Cognitivism and psychoanalysis; Ego autonomy; Ego states; Hungarian School.

### **Bibliography**

- Gill, Merton M. (1961). David Rapaport, 1911–1960. *Bulletin of the American Psychoanalytic Association*, 17, 755–759.
- . (Ed.). (1967). *The collected papers of David Rapaport*. New York: Basic Books.
- Knight, Robert P. (1961). David Rapaport 1911–1960. *Psychoanalytic Quarterly*, 30, 262–264.
- Rapaport, David. (1951). *Organization and pathology of thought*. New York: Columbia University Press.
- . (1959). The structure of psychoanalytic theory: A systematizing attempt. In S. Koch (Ed.), *Psychology: A study of a science*, vol. 3. New York: McGraw-Hill. (Reprinted in *Psychological Issues Monographs*, 6, 1960.)

## **RASCOVSKY, ARNALDO (1907–1995)**

Arnaldo Rascovsky, an Argentinean physician and psychoanalyst, was born in Córdoba, Argentina, on January 1, 1907, and died on May 1, 1995.

He graduated from the Medical School of the University of Buenos Aires when he was 22 years old, and became a pediatrician, much interested in neurology, endocrinology, and psychosomatic medicine. He became acquainted with Freudian ideas in 1936 and started his personal analysis with Angel Garma, who came to Argentina in 1938. Rascovsky was one of the pioneers of psychoanalysis in Argentina and in Latin America. He was the co-founder of the Argentine Psychoanalytic Association in 1942, first director of the *Revista de Psicoanálisis*, still appearing more than 50 years later in 2005. He was twice president of the Argentine Psychoanalytic Association and then honorary member of this association. He was the co-founder and president of COPAL/FePAL (Latin American Psychoanalytic Federation), founder and president of Filium (Interdisciplinary Association for the Study and Prevention of Filicide) and several times president of the Society of Psychological Medicine, Psychoanalysis and Psychosomatic Medicine, a branch of the Argentine Medical Association.

Rascovsky made important contributions to the understanding of the emotional troubles related to psychosomatic disease. His most original contribution to Psychoanalysis was his study of early psychic development and his theoretical and clinical approach to fetal psychism (*El psiquismo fetal*, 1960). The papers on feminine psychology written in collaboration with his wife Matilde Rascovsky (also a psychoanalyst) threw new light on the complex phenomena taking place in different moments of the feminine life cycle.

His numerous writings deal with the psychoanalytic understanding of psychosomatics, the conceptualization of fetal psychism from the metapsychological point of view, and the understanding and prevention of filicide (*El filicidio*, 1973; *La Universalidad del filicidio*, 1986). A gifted communicator, his lectures on television and radio stimulated psychoanalytic thought throughout Latin America. He is the author of more than 50 psychoanalytic papers and several books. He knew how to address parents, pediatricians, teachers, and the community in general in defense of childhood, mother-father-child relations, and to condemn sadism in teaching, and filicidal behavior.

He was a training analyst and teacher of the Argentine Psychoanalytic Association and full member of the International Psychoanalytical Association. He is considered to be one of the main pioneers of the Argentine Psychoanalytic Movement, highly cultivated, gifted, and generous in his teaching.

ELFRIEDE S. LUSTIG DE FERRER

See also: Argentina; Colombia; Federación psicoanalítica de América latina; *Revista de psicoanálisis*.

### Bibliography

- Rascovsky, Arnaldo. (1956). Beyond the oral stage. *International Journal of Psycho-Analysis*, 37, 4.
- . (1960). *El Piquismo Fetal*. Buenos Aires: Paidós.
- . (1973). *El Filicidio*. Buenos Aires: Orion.
- Rascovsky, Arnaldo, et al. (1971). *Niveles profundos del Piquismo*. Buenos Aires: Sudamericana.
- . (1986). *La universalidad del filicidio*. Buenos Aires: Legase.

---

**“RAT MAN”**. See “**Psycho-Analytic Notes of an Autobiographical Account of a Case of Paranoia (Dementia Paranoides)**”

---

## RATIONALIZATION

A rationalization is a logical or moral justification for an action or attitude that is provided by a subject whose (unconscious) motives are inaccessible. Two examples are justifying a fear of cancer by referring to other family members who suffered from the disease and justifying one’s compulsive washing by offering sanitary concerns. The term was introduced in psychoanalysis by Ernest Jones (1908).

Rationalization is not really a symptom. It is more a way of masking and denying the symptom. Nor is it a compromise formation, since within certain limits it satisfies the drive. Nor is it a defense mechanism, since it is not directed toward any libidinal satisfaction. It is more of a way to keep from recognizing neurotic conflicts. It is the conscious secondary thought process of covering the symptom with a screen.

Rationalization is primarily found in cases of neurosis: “Compulsive acts [that occur] in two successive stages, of which the second neutralizes the first, are a typical occurrence in obsessional neuroses. The patient’s consciousness naturally misunderstand them and puts forward a set of secondary motives to account for them—rationalizes them, in short” (Freud 1909d, p. 192).

Can the notion of rationalization be applied to delusion in particular, the logical delusion of paranoiacs? Some psychiatric studies have made use of an analogous concept to show how megalomania is caused by a need to explain and justify the feeling of persecution. In his essay on Judge Schreber, Freud rejects this formulation: “to ascribe such important affective consequences to a rationalization is, as it seems to us, an entirely unpsychological proceeding; and we would consequently draw a sharp distinction between our opinion and the one which we have quoted from the textbooks. We are making no claim, for the moment, to knowing the origin of the megalomania” (1911c [1910], p. 49).

Rationalization is sometimes compared to intellectualization, but the two concepts must be distinguished. In intellectualization, one distances oneself from psychic processes by cathecting one’s own intellectual processes and thought. Rationalization, in contrast, primarily finds support in systems of thought, representations, and beliefs that are socially constituted and accepted.

MICHÈLE BERTRAND

See also: Intellectualization; Jones, Ernest; Negative, work of the; Paranoia; Secondary revision; Thought.

### Bibliography

- Freud, Sigmund. (1909d). Notes upon a case of obsessional neurosis. *SE*, 10: 151–318.
- . (1911c [1910]). Psycho-analytic notes on an autobiographical account of a case of paranoia (*Dementia Paranoides*). *SE*, 12: 1–82.
- Jones, Ernest. (1908). Rationalization in everyday life. *Journal of Abnormal Psychology*.

---

## REACTION-FORMATION

“Reaction-formation” refers to an attitude or a character-trait that responds to an unconscious (repressed)

wish or desire by evoking the opposite of such a desire. For example, generosity covers or conceals avariciousness and hoarding; modesty may replace megalomania; kindness or reluctance to engage in conflict can mask sadistic tendencies. Reaction-formation is thus also a symptom of a psychic conflict and a defense against instinctive reactions.

Even though it occurs in various pathologies, reaction-formation is most readily apparent in cases of obsessional neurosis. In his early writings, Freud described the mechanisms of obsessive patients, discerning in them clear signs of conflicts of ambivalence through regression from tender to sadistic impulses. In “Instincts and Their Vicissitudes” (1915c), he distinguished between reaction formation and similar concepts, such as *substitute formation and compromise formation*, by showing that repression is carried out differently in each case. Thus, a hostile impulse towards a loved one is subject to repression, such an impulse itself being the result of regression of the erotic drive. At first the work of repression succeeds—that is, contents of the representation vanish and the associated affect disappears. A substitute formation would entail a modification of the ego through establishment of scruples of moral conscience, distinct from the symptom per se, that involves a compromise formation.

Reaction-formation, by contrast, serves repression by intensifying the opposite. However, although conceptually and chronologically distinct, reaction formation and substitute formations are not unrelated. The former distinguishes itself by the antithetical choice of the substitution, which at least indirectly implies ambivalence. And, contrary to compromise formation, the instinct inhibited with respect to a reaction formation is not represented. In fact, it remains active and in evidence in various situations, in the subject’s defensive rigidity and in specific contradictions to the reactive stance.

In *Three Essays on the Theory of Sexuality* (1905d), Freud gave reaction-formation a more extended meaning. He suggested it as a pathway to sublimation inasmuch as the instinct is diverted from its aim. Unlike sublimation, however, with reaction formation the instinctual aim is not merely different but is diametrically opposed to the original. On the other hand, reaction formation does not entirely succeed in this diversion, and the inhibited desire attempts constantly to resurface.

Reaction-formation can also become a permanent character trait and its significance can grow more

general; it can become not just a symptom of a specific pathology, but it heralds the process of socialization. We become social beings by acquiring, as permanent character-traits, “virtues” which move counter to our sexual goals. “A sub-species of sublimation is to be found in suppression by reaction-formation,” wrote Freud (1905c), “which...begins during a child’s period of latency and continues in favourable cases throughout his whole life. What we describe as a person’s ‘character’ is built up to a considerable extent from the material of sexual excitations and is composed of instincts that have been fixed since childhood, of constructions achieved by means of sublimation, and of other constructions, employed for effectively holding in check perverse impulses which have been recognized as being unutilizable. The multifariously perverse sexual disposition of childhood can accordingly be regarded as the source of a number of our virtues, in so far as through reaction-formation it stimulates their development” (pp. 238–239).

Reaction-formation is not restricted to character and moral virtues, but also includes the domain of thought and intellect. The counter-cathexis of the system of conscience, organized as a reaction formation, supplies the first repression (Freud, 1915d). In “Thoughts for the Times on War and Death” (1915b), Freud showed how altruism may originate from selfishness, and compassion from cruelty. “Noble” motives can have the same effect as “non-noble” motives. We cannot divine the instinctual life of a subject, however; we only can observe his or her behavior.

Humankind’s capacity to reshape instinctual selfishness is otherwise known as its aptitude for culture. People have unequal abilities in this regard, and the most solid among them may prove the least well-defended. This explains how instinctual remodeling can be more or less thoroughly undone by circumstance—war being an event that puts culture most completely at risk—and how acquired civility, or the capacity to conduct oneself towards others according to ethical considerations, may entirely unravel. Reaction-formation thus exposes the fragility of morality and suggests how repressed instincts are able to return with a great intensity, as acts of barbarism and cruelty.

MICHÈLE BERTRAND

*See also:* Ambivalence; Character; Compromise formation; Defense mechanisms; Desexualization; *Ego and the Mechanisms of Defense, The*; Libidinal development.

### **Bibliography**

- Freud, Sigmund. (1905d). *Three essays on the theory of sexuality*. *SE*, 7: 123–243.
- . (1915b). Thoughts for the times on war and death. *SE*, 14: 273–300.
- . (1915c). Instincts and their vicissitudes. *SE* 14: 109–140.
- . (1915d). Repression. *SE*, 14: 141–158.

---

**REALITY-EGO.** See *Pleasure ego/reality ego*

---

### **REALITY PRINCIPLE**

The reality principle is one of the two major principles that govern the workings of the mind. It designates the psyche's necessary awareness of information concerning reality and stands in contradistinction to the pleasure/unpleasure principle, which seeks the discharge or elimination of drive tension at all costs. Although the reality principle was formally introduced into the Freudian vocabulary in 1911 ("Formulations on the Two Principles of Mental Functioning"), it can be found in latent form in his thought as early as the 1895 "Project for a Scientific Psychology."

The need for such a concept arose at that time as a result of an internal contradiction in the pleasure principle, or more specifically, in the notion of hallucinatory wish fulfillment, which tends to mislead the mental apparatus and leave it traumatized by producing a satisfaction that is hallucinated rather than real.

It is therefore only by siding with the reality principle that the mental apparatus gives up the hallucinatory wish-fulfillment carried out by holding onto and binding its cathexes of traces of previous pleasures. It must be satisfied by representing what it wishes for, and engaging in the specific acting needed to make this wish a reality. This confirms why the reality principle is the effect of an internal transformation of the pleasure/unpleasure principle, because it arises first and foremost from the question of whether a pleasure is real, and because adaptation to reality is not its primary function. This transformation brings together both the question of external reality, concerning whether the object of satisfaction is present or absent,

and the question of internal reality, concerning whether pleasure is real.

As soon as it is in place, however, the reality principle comes into conflict with the pleasure principle, insofar as the latter seeks hallucinatory, immediate, wish-fulfillment. The reality principle, therefore, is the domain of the most "secondary" layers of the psychical apparatus. In the first topography it is expressed as the preconscious, and assumes its various qualities (perception, judgment, etc.).

However, in 1920 Freud in effect reversed the respective positions of the pleasure principle and reality principle when he overtly located a "beyond the pleasure principle"—a repetition compulsion—at the root of the psychical apparatus itself. The impact of early reality—whether "pleasurable" or not—becomes primary ("primitive" reality-ego), and the pleasure/unpleasure principle appears as secondary ("pure" pleasure-ego). Paradoxically, it would then be necessary to depict primary reality as falling under the primary of the reality principle ("definitive" reality-ego), due to the intervention of the external object.

RENÉ ROUSSILLON

See also: Principles of mental functioning.

### **Bibliography**

- Ferenczi, Sándor. (1968). Le développement du sens de la réalité et ses stades. In *O.C., Psychanalyse* (Volume 2, pp. 51–64). Paris: Payot. (Original work published 1913)
- Freud, Sigmund. (1911b). Formulations on the two principles of mental functioning. *SE*, 12: 213–226.
- . (1920g). Beyond the pleasure principle. *SE*, 18: 1–64.
- . (1950a [1887–1902]). *Extracts from the Fliess papers*. *SE*, 1: 173–280.
- Le Guen, Claude. (1995). Le principe de réalité psychique. *Revue française de psychanalyse*, 59(1), 9–25.

---

### **REALITY TESTING**

"Reality testing" is defined as the process through which the psyche gauges the difference between the internal and external worlds. Freud first defined this process as founded on perception and motility, but as

he progressively elaborated his theory of the ego, reality testing became one of the functions of the ego.

Freud's most complete description of this concept occurs in "A Metapsychological Supplement to the Theory of Dreams" (1916–1917f [1915]), where it appears in tandem with another concept, the "reality-indicator," which makes it possible for the psyche to determine whether the experience it is undergoing is present or is the recall of a previous one. The need for both of these concepts in psychoanalysis stems from the psyche's proclivity to hallucinate. If a previous experience is hallucinated, meaning made present to perception by the action of intense instinctual cathexis, this may fog up the ego's capacities to differentiate between past and present, internal and external, and thus require it to refer to the intensity of the cathexis to differentiate between actual perception and hallucination.

In Freud's inaugural texts, the ego's capacity to make and change cathexes devolves upon reality testing. In the texts that followed, this capacity was assumed by perception, which conveys external reality inward (1911b), then motility, which enables flight from extreme sources of excitation and thereby enables the ego to differentiate the excitation from internal sources (1916–1917f).

However, all of these processes assume means that cannot be used in the psychoanalytic session, where motility and perception are in large part suspended. Freud's successors, Winnicott in particular, have therefore emphasized another process that contributes to distinguishing the realm of fantasy and differentiating internal and external realities. This process is based on the fact that external reality resists fantasized destruction and is not destroyed by it. Reality, or rather externality, can thus be discovered by its capacities to resist the subject's destructiveness. This confers upon the analysis of negative transference a preponderant role in treatment.

RENÉ ROUSSILLON

*See also:* Act, passage to the; Anxiety; Danger; Dementia; Depressive position; Experience of satisfaction; Group phenomenon; Idea/representation; Illusion; Internal/external reality; Isakower phenomenon; Mythology and psychoanalysis; *Outline of Psycho-Analysis, An*; Psychoanalytic nosography; Splitting of the ego; Truth; Wish, hallucinatory satisfaction of a; Wish/yearning.

### **Bibliography**

- Freud, Sigmund. (1911b). Formulations on the two principles of mental functioning. *SE*, 12: 213–226.
- . (1916–1917f [1915]). A metapsychological supplement to the theory of dreams. *SE*, 14: 217–235.

### **Further Reading**

- Abend, Sander. (1982). Reality testing as a clinical concept. *Psychoanalytic Quarterly*, 51, 218–238.
- Arlow, Jacob. (1969). Fantasy, memory, and reality testing. *Psychoanalytic Quarterly*, 38, 28–51.

---

## **REALIZATION**

Implicit in Wilfred R. Bion's concept of inherent pre-conceptions is the notion of the future of the preconception in a realization in actual experience with its anticipated counterpart; thus, the infant's inherent preconception of a breast becomes mated with the actual breast that is found and becomes *real-ized* as a conception. Repeated confirmatory experiences of that kind eventually confirm the anticipated experience as a concept. Thus, *realization*, in its capacity to confirm that which has already been autochthonously predicted or expected, bestows confidence, faith, and security to the infant's sense of survival and thriving.

The concept of realization becomes even more ratified when the infant is able to tolerate frustration and thereby allow for the experience of the absence of the breast in the context of having faith in its return. Otherwise, in the case of the infant who cannot tolerate frustration, the experience of the absent breast is eclipsed by the negative experience of the "nobreast present," a concrete image of a bad, persecuting breast.

The concept of realization belongs to Bion's epistemological forays into the fundamental understanding of thinking and is associated with his notions of projective identification, alpha function, and container/contained. The inherent preconception of a breast searches for the realization of the breast in the context of felt neediness if there is an allowance for an absence of a breast that awaits fulfillment and exploratorily and projectively identifies itself in the realized breast. The object of the search who possesses the needed breast is the maternal container who is summoned by the outcry of the infant and his preconception of the

breast. The container must appose itself accommodatingly so as to contain the infant's anxiety of non-confirmation (negative realization).

JAMES GROTSSTEIN

See also: Catastrophic change; Concept; Container-contained; Invariant; Preconception; *Learning from experience*.

**Bibliography**

Bion, W. R. (1962). *Learning from experience*. London: Heinemann; New York: Basic Books.

———. (1962). A theory of thinking. *International Journal of Psycho-Analysis*, 43, 4–5; in *Second thoughts*. London: Heinemann, 1967.

**REAL, SYMBOLIC, AND IMAGINARY FATHER**

As Freud had already emphasized, the rather complicated paternal function is not assumed only by the real father, the progenitor, and the mother's partner. In his seminar on *Object Relations* (1956–57), Lacan proposed, based on his rereading of Freud's case of "Little Hans," a distinction between the actual father and the function of the father in its real, symbolic, and imaginary instances. In the reality of the child's life, these instances are incarnated by a variety of actual agents.

From the Lacanian perspective, the instance of the *real father* (a term that Lacan sometimes uses in the sense of the "father in reality") is not only embodied by the biological father or even the man who lives with the mother, that is, by a "Dad" with his own history, qualities, shortcomings, and psychic structure. The real father—insofar as "he" desires the mother and is the object of her desire—is also, and even primarily, embodied by anything that carries out the child's symbolic castration, that is, both the renunciation and the realization of the child's incestuous desire. Moreover, because he finds *jouissance* in a woman, this father does not seek an incestuous *jouissance* in the child. Still more broadly conceived, the real father is any being that, either in reality or by means of its reality, leads the child to give up being the mother's phallus, on the one hand, and leads the mother to give up trying to make the child into her phallus, on the other. This symbolic castration determines the way in which the boy and the girl will

**FIGURE 1**

<b>Real of the father</b>		
<b>Symbolic father</b>		
<b>Real father</b>	<b>Symbolic mother</b>	<b>Imaginary father</b>
Real father(s) or father(s) in reality	Real mother(s) or mother(s) in reality	Real child or child in reality

assume their masculinity and femininity. Insofar as fathers in reality are always somehow lacking as an embodiment of the symbolic father and cannot measure up to the imaginary father, to which they are inevitably compared, the real father also partially represents for the child the category of the impossible (Figure 1).

It should be noted that Lacan sometimes uses the term *real father* in a completely different way (in the sense of the "real of the father") to designate that which is impossible for us to say concerning the father. This is the unthinkable father, the primal father that Freud was unable to bring to light except in the myth that he developed in *Totem and Taboo*.

The imaginary father is the product of the child's imagination and finds support in the various cultural representations of the father as terribly tyrannical or immensely good, execrable or adorable, terrifying or fascinating. Inevitably, the child makes the actual father wear the masks and disguises of one or the other of these imaginary fathers. Even though the imaginary father can in some ways be a source of suffering, usually neurotic or masochistic, he is not entirely without beneficial effects, because he gives weight to the symbolic father and thus protects the father against the ravaging effects of the all-powerful archaic mother.

The *symbolic father* includes the two others. This more general instance of the father, also called the Name-of-the-Father, protects the child against psychosis. He imposes castration through the intervention of the real father (embodied in the actual father), frustration through the intervention of the symbolic mother, and privation through the mediation of the imaginary father. This all-encompassing instance of the father installs a definitive gap between the child and the mother, just as it institutes a distinction between the sexes and the generations.

The *symbolic mother*, as embodied by any particular mother, participates by her speech and acts (her

absences, for example) in making present the Law of the father.

PATRICK DE NEUTER

*See also:* Fatherhood; Name-of-the-Father.

### **Bibliography**

- De Neuter, Patrick. (1993). Fonctions paternelles et naissances du sujet. *Cahiers des sciences familiales et sexologiques*, 16, 105–127.
- Dor, Joël. (1989). *Le Père et sa Fonction en psychanalyse*. Paris: Point hors ligne.
- Julien, Philippe. (1991). *Le Manteau de Noé: Essais sur la paternité*. Paris: Desclée de Brouwer.
- Lacan, Jacques. (1956–1957). *Le Séminaire-Livre IV, La Relation d'Objet*. Paris: Seuil, 1994.
- . (1959). À la mémoire d'Ernest Jones: Sur sa théorie du symbolisme. In his *Écrits*. Paris: Seuil, 1966.

## **REAL, THE (LACAN)**

The real, a category established by Jacques Lacan, can only be understood in connection with the categories of the symbolic and the imaginary. Defined as what escapes the symbolic, the real can be neither spoken nor written. Thus it is related to the impossible, defined as “that which never ceases to write itself.” And because it cannot be reduced to meaning, the real does not lend itself any more readily to univocal imaginary representation than it does to symbolization. The real situates the symbolic and the imaginary in their respective positions.

In 1953, in a lecture called “Le symbolique, l’imaginaire et le réel” (The symbolic, the imaginary, and the real; 1982), Lacan introduced the real as connected with the imaginary and the symbolic. The real, insofar as it is situated in relation to the death drive and the repetition compulsion, has nothing to do with Freudian reality (*Wirklichkeit*) or with the reality principle. Lacan wrote, “One thing that is striking is that in analysis there is an entire element of the real of the subject that escapes us. . . . There is something that brings the limits of analysis into play, and it involves the relation of the subject to the real” (1982). Right away, Lacan raised the question of the real in relation to analytic training, and in 1953 more specifically in relation to

the choice of candidates for training analysis. The issue concerned the fact that the real is defined not solely by its relation to the symbolic but also by the particular way in which each subject is caught up in it.

Lacan was able to extract this notion of the real from his meticulous reading of Freud. In *La relation d’objet* (Object relations; 1994), his seminar of 1956–1957, Lacan, taking up the case of “little Hans” (Freud, 1909b), explained the boy’s mythical constructions as a response to the real of sexual jouissance (enjoyment) that had erupted in his field of subjectivity. Thanks to his imaginary constructions and his phobia, little Hans avoided the issue of castration. In his seminar *The Ego in Freud’s Theory and in the Technique of Psychoanalysis, 1954–1955* (1988), Lacan presented a detailed reading of Freud’s dream of Irma’s injection (Freud, 1900a). He emphasized that the terrifying image that Freud saw at the back of Irma’s throat revealed the irreducible real and designated a limit point at which “all words cease” (1988, p. 164).

Lacan returned regularly to *The Interpretation of Dreams* (Freud, 1900a) to indicate how the real is located at the root of every dream, what Freud called the dream’s navel, a limit point where the unknown emerges (1900a, pp. 111n, 525). It is here, at the dream’s navel, that Lacan located the point where the real hooks up with the symbolic (Lacan, 1975). Lacan approached the real through hallucination and psychosis by careful study of Freud’s “Wolf man” case (1918b [1914]), Freud’s commentary on Daniel Paul Schreber (1911c [1910]), and “Negation” (Freud, 1925h). If the Name of the Father is foreclosed and the symbolic function of castration is refused by the subject, the signifiers of the father and of castration reappear in reality, in the form of hallucinations. Hence the Wolf Man’s hallucination of a severed finger and Schreber’s delusions of communicating with God. Thus, in developing the concept of foreclosure, Lacan was able to declare, “What does not come to light in the symbolic appears in the real” (1966, p. 388). Lacan reconceived Freud’s hypothesis of an original affirmation as a symbolic operation in which the subject emerges from an already present real and recognizes the signifying stroke that engages the subject in a world symbolically ordered by the Name of the Father and castration. In his seminar *The Four Fundamental Concepts of Psychoanalysis* (1978), Lacan took up Freud’s *Beyond the Pleasure Principle* (1920g) and approached the real in terms of compulsion and



repetition. He proposed distinguishing between two different aspects of repetition: a symbolic aspect that depends on the compulsion of signifiers (automaton) and a real aspect that he called *tuché*, the interruption of the automaton by trauma or a bad encounter that the subject is unable to avoid. Engendered by the real of trauma, repetition is perpetuated by the failure of symbolization. From this point on, Lacan defined the real as “that which always returns to the same place” (Lacan, 1978, p. 49). Trauma, which Freud situated within the framework of the death drive, Lacan conceptualized as the impossible-to-symbolize real.

The concept of the real also allowed Lacan to approach questions of anxiety and the symptom in a new way. While his early teaching was devoted to the primacy of the symbolic, in later seminars (from 1972 to 1978) he argued that the real (R), the symbolic (S), and the imaginary (I) are strictly equivalent. In effect, the symbolism that Lacan borrowed from logic failed to formalize the real, which “never ceases to write itself.” Thus Lacan attempted, by borrowing from the mathematics of knot theory, to invent a formulation independent of symbols. By affirming the equivalence of the three categories R, S, and I, by representing them as three perfectly identical circles that could be distinguished only by the names they were given, and by knotting these three circles together in specific ways (such that if any one of them is cut, the other two are set free), Lacan introduced a new object in psychoanalysis, the Borromean knot. This knot is both a material object that can be manipulated and a metaphor for the structure of the subject. The knot, made up of three rings, is characterized by how the rings (representing the real, the symbolic, and the imaginary) interlock and support each other. From this point on in Lacan’s teaching, the real was no longer an opaque and terrifying unconceptualizable entity. Rather, it is positioned right alongside the symbolic and tied to it by mediation of the imaginary. Thus, whatever our capacity for symbolizing and imagining, there remains an irreducible realm of the nonmeaning, and that is where the real is located (see Lacan, 1974–1975).

In the final years of his teaching, Lacan took up the question of the symptom and the end of the treatment (1975; 1976). If the symptom is “the most real thing” that subjects possess (1976, p. 41), then how must analysis proceed to aim at the real of the symptom in order to ensure that the symptom does not proliferate in meaningful effects and even to eliminate the symptom?

For analysis not to be an infinite process, for it to find its own internal limit, the analyst’s interpretation, which bears upon the signifier, must also reach the real of the symptom, that is, the point where the symbolically nonmeaningful latches on to the real, where the first signifiers heard by the subject have left their imprint (Lacan, 1985, p. 14). According to Lacan, to reach its endpoint, an analysis must modify the relationship of the subject to the real, which is an irreducible whole in the symbolic from which the subject’s fantasy and desire derive.

This notion of the real has given rise to numerous misunderstandings. Some have interpreted its resistance to formalization as a slide into irrationality. Others, by identifying the real with trauma, have made it a cause of fear and anxiety. Yet we all have an intuitive experience of the real in such phenomena as the uncanny, anxiety, the nonmeaningful, and poetic humor that plays upon words at the expense of meaning. Thus, when the framework of the imaginary wavers and speech is lacking, when reality is no longer organized and pacified by the fantasy screen, the experience of the real emerges in a way that is unique for each person.

MARTINE LERUDE

*See also:* Fantasy, formula of; Foreclosure; Fragmentation; Imaginary, the; Internal/external reality; Knot; Object *a*; Real, Symbolic, and Imaginary father; Signifier; Subject’s castration; Symbolic, the; Symptom/sinthome.

### Bibliography

- Freud, Sigmund. (1900a). The interpretation of dreams. *SE*, 4: 1–338; 5: 339–625.
- . (1909b). Analysis of a phobia in a five-year-old boy. *SE*, 10: 1–149.
- . (1911c [1910]). Psycho-analytic notes on an autobiographical account of a case of paranoia (*dementia paranoides*). *SE*, 12: 1–82.
- . (1918b [1914]). From the history of an infantile neurosis. *SE*, 17: 1–122.
- . (1920g). Beyond the pleasure principle. *SE*, 18: 1–64.
- . (1925h). Negation. *SE*, 19: 233–239.
- Lacan, Jacques. (1966). *Écrits*. Paris: Seuil.
- . (1974–1975). Le séminaire. Book 22: R.S.I. *Ornicar?*, 2–5.

- . (1975). La troisième, intervention de J. Lacan le 31 octobre 1974. *Lettres de l'École Freudienne*, 16, 178–203.
- . (1976). Conférences et entretiens dans les universités nord-américaines. *Scilicet*, 6–7, 5–63.
- . (1978). *The seminar of Jacques Lacan*. Book 11: *The four fundamental concepts of psycho-analysis* (Alan Sheridan, Trans.). New York: W. W. Norton. (Original work published 1973)
- . (1982). Le symbolique, l'imaginaire et le réel. *Bulletin de l'Association Freudienne*, 1, 4–13.
- . (1985). Geneva lecture on the symptom (Russell Grigg, Trans.). *Analysis*, 1, 7–26. (Original work published 1975)
- . (1988). *The seminar of Jacques Lacan*. Book 2: *The ego in Freud's theory and in the technique of psychoanalysis, 1954–1955* (Sylvana Tomaselli, Trans.). New York: W. W. Norton. (Original work published 1978)
- . (1994). *Le séminaire*. Book 4: *La relation d'objet (1956–1957)*. Paris: Seuil.

## REAL TRAUMA

A real trauma has an exogenous cause and its disturbing, even disruptive effect is immediate and manifest.

This has been the usual definition of *trauma* ever since its adoption in a surgical context in 1855: The word always denoted a bodily injury, but its meaning was soon expanded to alone cover the state of shock or stupor induced by that injury. The adjective *real* has no meaning save by way of contrast with the psychoanalytic notion of psychical trauma. Freud used it to qualify not the trauma per se but rather those childhood scenes of seduction, which according to his theory of seduction, constituted the first moment of the trauma.

Although he abandoned this theory, thereby promoting the ideas of unconscious fantasy and psychic reality, Freud argued unwaveringly for the existence of real violent events and their pathogenic effects. By contrast, the majority of his immediate followers, failing to assimilate the oscillation throughout Freud's work between reality and fantasy, gave precedence to fantasy, to the omnipotence of thought, and evinced a distinct distrust of reality. Present-day analysts tend to pay more attention to the real event in its traumatic brutality, while recognizing that this does not free them from the task of thoroughly following the fantasy activity which that reality sets in motion; they espouse the eco-

nomic view of the trauma, as set forth by Freud in 1920, according to which the nature and intensity of a traumatic event can make it highly disruptive in its effects.

The underlying problem here, so often debated, is the nature of internal as opposed to external reality, an issue that occasioned a profound disagreement between Freud and Ferenczi. Even if the impact of reality—of the “bedrock” of biology and of event-governed history—is inescapable, there can be no question, despite all that, of reducing the trauma to a strictly objective reality.

Talk of real trauma might suggest that there is such a thing as fictitious, imaginary, or even “fraudulent” traumas. The term is somewhat questionable therefore, and is in fact little used in psychoanalysis. Quite obviously, any trauma, whatever its origin, is distinctly “real” in its effects.

FRANÇOISE BRETTE

See also: *Construction de l'espace analytique, La*; Internal/external reality; Trauma.

## Bibliography

- Ferenczi, Sándor. (1931). Child analysis in the analysis of adults. In *Final contributions to the problems and methods of psycho-analysis*. London: Hogarth/Institute of Psycho-Analysis, 1955.
- . (1933 [1932]). Confusion of tongues between adults and the child. In *Final contributions to the problems and methods of psycho-analysis*. London: Hogarth/Institute of Psycho-Analysis, 1955.
- Freud, Sigmund. (1896c). The aetiology of hysteria. *SE*, 3: 186–221.
- . (1920g). *Beyond the pleasure principle*. *SE*, 18: 1–64.
- Freud, Sigmund, and Sándor Ferenczi. (1993–2000). *The correspondence of Sigmund Freud and Sándor Ferenczi*. (Eva Brabant, et al., Eds., Peter T. Hoffer Trans.; 3 volumes) Cambridge, MA/London: Belknap Press of Harvard University Press.

## RECIPROCAL PATHS OF INFLUENCE (LIBIDINAL COEXCITATION)

The expression *reciprocal paths of influence* refers to routes that lead from a nonsexual function to a sexual function, but that can be traversed in both directions.

In *Three Essays on the Theory of Sexuality* (1905d) Sigmund Freud added to the somatic sources of sexual excitation (erotogenic zones) other sources that are unlimited in number, since they involve any internal process that has surpassed a certain quantitative threshold.

Two aspects of this notion of reciprocal paths of influence must be distinguished.

- First, the anaclitic relationship of the sexual function to a given physiological function sexualizes the latter (Laplanche, 1976). Thus the lips or the tongue intervene in the act of taking nourishment, but also in the pleasure that is taken in this act (or repudiated, as in anorexia), and that which can be found outside of the vital function. This aspect makes it possible to understand the alteration of physiological functions (somatization) that in and of themselves do not have a sexual character, but have taken it on secondarily and can thus undergo the process of repression.
- Second, a nonsexual activity such as intellectual effort, for example, can, if a sufficient amount of concentration accompanies it, create a related sexual excitation. This case does not, therefore, involve an anaclitic dependence on a bodily function, but rather an indirect source of sexual excitation that is in fact linked to the degree of cathexis at stake. In *Three Essays on the Theory of Sexuality*, Freud concluded that “it may well be that nothing of considerable importance can occur in the organism without contributing some component to the excitation of the sexual instinct” (pp. 204–205).

This hypothesis is extremely important because it makes it possible simultaneously to account for sublimation (attraction of the sexual toward the nonsexual) and symptom formation (attraction of the nonsexual toward the sexual). In fact, it considerably broadens the notion of sexuality to encompass the notion of “pleasure in thinking,” a very different perspective from the one that equates thinking with labor.

SOPHIE DE MIJOLLA-MELLOR

See also: Erotogenic masochism; Fusion/defusion of instincts; Intellectualization; Masochism; Pleasure in thinking; Thought.

## Bibliography

- Freud, Sigmund. (1905d). Three essays on the theory of Sexuality. *SE*, 7: 123–243.
- Laplanche, Jean. (1976). *Life and death in psychoanalysis*. Baltimore, MD: Johns Hopkins University Press.
- Mijolla-Mellor, Sophie de. (1992). *Le Plaisir de pensée*. Paris: Presses Universitaires de France.

## “RECOMMENDATIONS TO PHYSICIANS PRACTISING PSYCHOANALYSIS”

“The technical rules which I am putting forward here have been arrived at from my own experience in the course of many years, after unfortunate results had led me to abandon other methods” (1912e, 111). Thus began Sigmund Freud’s “Recommendations to Physicians,” which is, together with “The Handling of Dream Interpretation in Psychoanalysis” (1911e) and “The Dynamics of Transference” (1912b), among the rare technical essays that resulted from Freud’s 1908 attempt to write a “general methodology,” a project he abandoned in 1910.

Freud went on to specify that these recommendations were the result of his own methods and that it was possible that another physician would assume a different position. But he insisted on their common goal, which was to establish for the analyst conditions that paralleled the “fundamental rule” imposed on the patient. It was in line with this that he recommended an attitude of “evenly suspended attention,” the use of “unconscious memory” rather than notes, the absence of a preconceived research “plan,” and therefore the adoption of an attitude of “distance” similar to that of a surgeon.

“The doctor should be opaque to his patients and, like a mirror, should show them nothing but what is shown to him” (1912e, p. 118). We know the fate of this metaphor, as we do that of the other metaphor that Freud would later return to: “To put it in a formula: [the analyst] must turn his own unconscious like a receptive organ towards the transmitting unconscious of the patient. He must adjust himself to the patient as a telephone receiver is adjusted to the transmitting microphone. Just as the receiver converts back into soundwaves the electric oscillations in the telephone line which were set up by sound waves, so the doctor’s unconscious is able, from the derivatives of

the unconscious which are communicated to him, to reconstruct that unconscious, which has determined the patient's free associations" (1912e, p. 115–116). It was to Ludwig Binswanger, who was surprised at a recommendation so similar to telepathy, that, on February 22, 1925, Freud made the following comment: "The statement that the unconscious of the analysand must be seized with one's own unconscious, that we must so to speak hold out the unconscious ear as a receiver, was one I made in an unassuming and rationalistic sense, although I grant that important problems are concealed behind that formulation. I simply meant that one must eschew the conscious intensification of certain expectations and so set up in oneself the same state one requires of the analysand. All ambiguities disappear once you assume that, in the sentence in question, the unconscious is meant purely descriptively. In a more systematic formulation, unconscious must be replaced with preconscious."

In order for this balance to occur, the analyst must first undergo an "analytic purification." This is the inception, by Freud himself, of the "training analysis," intended to help the analyst avoid the temptation of using his own life as an example or trying to educate the patient.

It is clear from this essay that Freud is responding indirectly to the errors that the first psychoanalysts inevitably made in their eagerness to understand or heal. It also shows how difficult it was for physicians to adopt the psychoanalytic attitude when, as a result of their training and professional experience, they had developed an active attitude, if not that of a miracle worker, the very attitude that characterized Freud in the *Studies on Hysteria*. Have the times really changed? Freud's "Recommendations" has continued to be read and, as Freud wrote to Ludwig Binswanger on May 28, 1911, "In truth there is nothing for which man's disposition befits him less than occupying himself with psychoanalysis."

ALAIN DE MIJOLLA

See also: *Question of Lay Analysis, The*.

### Source Citation

Freud, Sigmund. (1912e). Ratschläge für den Arzt bei der psychoanalytischen Behandlung. *Zentralblatt für Psychoanalyse*, II: 483–489; *GW*, VIII: 376–387; Recommendations to physicians practising psycho-analysis. *SE*, 12: 111–120.

### Bibliography

Freud, Sigmund, and Binswanger, Ludwig. (1992 [1908–1938]). *The Sigmund Freud-Ludwig Binswanger Correspondence 1908–1938* (Gerhard Fichtner, Ed.; Arnold J. Pomerans and Tom Roberts, Trans.). New York: Other Press.

### REES, JOHN RAWLINGS (1890–1969)

A British physician and psychiatrist, John Rawlings Rees was born on June 25, 1890, in Leicester and died on April 11, 1969, in London. He was a Commander of the British Empire and a Fellow of the Royal College of Physicians.

Rees came from a religious background, his father having been a Wesleyan Methodist minister (non-conformist Protestant). He had thought of becoming a missionary, but instead studied medicine. His sense of mission was fulfilled by his leadership at the Tavistock Clinic before World War II, later as chief psychiatrist to the British Army and, after the war, founding and becoming the first president of the International Federation for Mental Health. Rees served as a doctor in World War I, in France, Mesopotamia, and India. There he saw soldiers with nervous breakdowns who were not well treated. He ensured that good treatment was available in World War II. He wrote that it was through his military experiences that he grew up emotionally.

At first he was interested in public health, but moved into psychiatry through meeting with Hugh Crichton-Miller, a pioneer psychotherapist who had founded Bowden House, an in-patient clinic for the early treatment of psychiatric illness. Later Crichton-Miller founded the Tavistock Clinic. Rees did not train as a psychoanalyst, though he had a personal analysis with Morris Nicoll, a Jungian. He was a fine administrator and teacher, who recognized his limits as a therapist. Crichton-Miller resigned in 1932, having grown out of sympathy with developments at the Tavistock, and Rees succeeded him as director. Under his leadership the clinic grew to becoming the main center for psychoanalytic psychiatry in the United Kingdom, in opposition to the Maudsley Hospital at the University of London.

Rees encouraged training in psychiatric social work and child guidance. In the 1930s the clinic was eclectic, with Jungian, Adlerian, and other psychotherapists of many persuasions. Its leading figures were James Arthur Hadfield and Ian Suttie, whose 1935 book *The*

*Origins of Love and Hate* had an important impact in British psychotherapy. Both John Bowlby and Donald Winnicott acknowledged this influence. Suttie attempted to integrate the individual, the social, and the spiritual. Among the staff in the 1930s was Wilfred R. Bion, who treated Samuel Beckett. Henry V. Dicks, for many years his colleague, described Rees “as a natural unself-conscious leader and originator.”

Rees was surprised to be invited in 1939 to take command of British Army psychiatry. He found that there were hardly any psychiatrists in the army at that time and quickly assembled a team, many of whom had served under him at the Tavistock. Rees was able to cooperate with the military hierarchy and to persuade and to show them the value of psychiatry in the selection and allocation of soldiers to work appropriate to their personality and intelligence; in the rehabilitation of psychiatric casualties; and in the maintenance of good morale. He was ably assisted by Ronald Hargreaves. Through their work senior psychiatrists were appointed to army groups and were recognized as valuable advisors.

The education and training of soldiers with limited intelligence was a major innovation in wartime which cleared the way to post-war developments in this field. By 1945 there were 300 trained army psychiatrists and Rees had been promoted to brigadier. After World War II the Tavistock was a changed institution as the younger generation had experienced power and influence in the armed forces, and they were enthusiastic to train in psychoanalysis and to use psychoanalytic knowledge in their work with the clinic. Rees was out of tune with this development and felt pressured to give up as director in 1947.

At the age of 57 he was at the height of his powers and devoted himself to organizing the first Mental Health Congress in London in 1948. He became the leading figure in the movement to maintain and develop wartime international cooperation among psychiatrists. His mission then became the research and treatment of mental illness in its social roots. He was a leading figure in the formation of the World Federation for Mental Health of which he was director for many years. The Federation brought modern psychiatry to undeveloped countries, trained their personnel, and stimulated research. He was indefatigable in his travels, and his London home was always a place of welcome for colleagues worldwide.

Rees published an autobiographical volume, *Reflections*. His own writings were not original, but he was

able to explain psychotherapy in straightforward terms to the general public, and his work in exploring society was influential.

MALCOLM PINES

See also: Great Britain; Tavistock Clinic.

### Bibliography

- King, Pearl H.M. (1982). Activities of British psychoanalysts during the Second World War and the influence of their interdisciplinary collaboration on the development of psychoanalysis in Great Britain. *International Review of Psycho-Analysis*, 16, 15–33.
- Rees, John Rawlings. (1929). *The health of the mind*. London: Faber & Faber; New York: W. W. Norton, 1951.
- . (1943). Three years of military psychiatry in the United Kingdom. *British Medical Journal*, 2.
- . (1944). A brief impression of British military psychiatry. *Bulletin of the Menninger Clinic*, 8, 29–35.
- . (1945). *The shaping of psychiatry by war*. New York: W. W. Norton.

## RÉGIS, EMMANUEL JEAN-BAPTISTE JOSEPH (1855–1918)

Emmanuel Régis, a French physician, was born on April 29, 1855, in Auterive (Haute-Garonne) and died on June 21, 1918, in Bordeaux. He studied medicine in Paris, where he was taught by Baillarger, Lasègue, Motet, Falret, and Ball, and became a professor at the Sainte-Anne psychiatric hospital, where he became assistant physician in 1881. In 1883 Régis was back in Bordeaux. Asked to teach a course on mental illness in 1892 by Albert Pitres, he became head of the department of medicine, then associate professor in 1905. In 1913 Régis was appointed to the new chair of mental pathology, which he held until his death.

Régis is the author of several works in the field of criminal psychology and mental illness. His approach to etiology is based on the notion of degeneration and the importance of an accidental toxic-infectious factor, ideas that were consistent with his training and oriented his important work in medical hygiene. Under the influence of Pitres, a well-known student of Charcot, he explored the study of neuroses and, like him, was forced to

confront the paradoxes of hysteria. It was while studying hysteria that both men encountered the ideas of Sigmund Freud, whose nosographic conceptions they shared without accepting his hypothesis of an underlying sexual etiology.

The article “Séméiologie des obsessions et idées fixes” (Pitres and Régis, *Archives de neurologie*, 1897) reflects this critical rapprochement. *Les Obsessions et les Impulsions* (1902) followed, developing points of view that Régis would again return to in the four editions of his *Précis de psychiatrie*. Régis’s opinion of Freudian theory is ultimately negative, but Freud continued to arouse his curiosity. Thus, in 1913, together with his assistant Angélo Hesnard and his brother, a learned German linguist, he initiated a project of reading all of Freud’s works. This resulted in the article, “La doctrine de Freud et de son école” (Régis and Hesnard, *L’Encéphale*, 1913) and *La Psychanalyse des névroses et des psychoses* (1914).

This book, in which Régis challenges the scientific value of psychoanalysis while recognizing its heuristic usefulness, has the merit, as Ferenczi acknowledged in his 1915 polemic, of describing Freudian theory accurately, supported by an exhaustive bibliography. The book marks the official entry of psychoanalysis in France.

GÉRARD BAZALGETTE

*See also:* Breton, André; Claustrophobia; France; Hesnard, Angélo Louis Marie; Phobias in children; Phobia of committing impulsive acts.

### **Bibliography**

Ferenczi, Sandor. (1939). Die psychiatrische Schule von Bordeaux über die Psychoanalyse. In Sandor Ferenczi, *Bausteine zur Psychoanalyse* (Vol. 4; pp. 12–45). Bern: Hans Huber (Original work published 1915).

Pitres, Albert, and Régis, Emmanuel. (1902). *Les Obsessions et les Impulsions*. Paris: O. Doin.

Régis, Emmanuel. (1909). *Précis de psychiatrie* (4th ed.). Paris: Doin.

———. (1913). La doctrine de Freud et de son école. *L’Encéphale*, 8, 356–378, 537–564.

Régis, Emmanuel, and Hesnard, Angélo. (1914). *La Psychanalyse des névroses et des psychoses. Ses applications médicales et extra-médicales*. Paris: Félix Alcan.

## **REGRESSION**

The Latin equivalent of *regression* means “return” or “withdrawal”; it also signifies a retreat or a return to a less-evolved state. There is no very precise psychoanalytic definition of the concept of regression. It is useful to introduce the idea of temporality. It could be said to represent an articulation between the atemporality of the unconscious, the primary processes, and the temporality of the secondary processes. Some analysts assign this notion a metaphoric value; it retains the connotations of a journey through time and the changes that will be necessary in psychoanalytic treatment.

Sigmund Freud introduced the notion of regression in *The Interpretation of Dreams* (1900a). The concept was necessary for his description of the psychic apparatus in terms of a topographical model, represented by an instrument whose component parts are agencies or systems with a spatial orientation. Excitation traverses the system in a determined temporal order, going from the sensory end to the motor end. In hallucinatory dreams, excitation follows a retrograde pathway. Dreams have a regressive character due to the shutdown of the motor system; the trajectory goes in the reverse direction, toward perception and hallucinatory visual representation. This regression is a psychological particularity of the dream process, but dreams do not have a monopoly on it. In the section of the last chapter of *The Interpretation of Dreams* titled “Regression,” Freud wrote that “in all probability this regression, wherever it may occur, is an effect of a resistance opposing the progress of a thought into consciousness along the normal path.... It is to be further remarked that regression plays a no less important part in the theory of the formation of neurotic symptoms than it does in that of dreams” (pp. 547–548). In this last chapter Freud already distinguished between three types of regression: topographical regression, in the sense of the psychic system; temporal regression, in the case of a return to earlier psychic formations; and formal regression, where primitive modes of expression and representation replace the usual ones. He also noted: “All these three kinds of regression are, however, one at bottom and occur together as a rule; for what is older in time is more primitive in form and in psychical topography lies nearer to the perceptual end” (p. 548). This basic unity is central to his metapsychological use of the concept.

In *Three Essays on the Theory of Sexuality* (1905d) Freud implicitly invoked the idea of fixation, which is inseparable from regression. In “A Metapsychological Supplement to the Theory of Dreams” (1916–17f [1915]), he underscored the distinction between “temporal or developmental regression” (of the ego and the libido) and topographical regression, and the fact that “[t]he two do not necessarily always coincide” (p. 227). Then, in the twenty-second of the *Introductory Lectures on Psychoanalysis* (1916–17a [1915–17]), he distinguished two types of regression affecting the libido: a return to the earliest objects marked by the libido, which are of an incestuous nature, and a return of the entire sexual organization to earlier stages. Libidinal regression is only an effect of temporal regression, with a reactivation of old libidinal structures preserved by fixation. At that point he asserted that regression was a “purely descriptive” concept, adding: “we cannot tell where we should localize it in the mental apparatus” (pp. 342–343). In making this assertion, he retrenched from his earlier position and denied regression its metaphysical status, which it would regain only after 1920 with the second theory of the instincts. It then becomes constitutive of the death instinct and can threaten to destroy psychic structures, but also becomes a mechanism that can be used by the ego.

According to Marilia Aisenstein’s article “Des régressions impossibles?” (Impossible regressions?), “Freud’s reticence around the notion of regression in 1917 was linked to its relation to the first theory of the instincts and the first topography. He had difficulty in situating and formulating regression not only in topographical terms, but above all in terms of the libido and the instincts of the ego. . . . It then became necessary to separate regression from disorganization, as the latter was envisioned by Pierre Marty and the psychosomaticians of the Paris School. . . . If the retrograde movement is not stopped by regressive systems involving fixations, the end result can be a process of somatization.” Regression is indispensable to the work of psychoanalytic treatment; it implies the notion of change and is part of the healing process, according to Donald W. Winnicott (1958). Regression is a form of defense and remains in the service of the ego. From the analyst’s point of view, formal regression provides another way of listening.

MARTINE MYQUEL

See also: Acute psychoses; Amphimixia/amphimixis; Benign/malignant regression; Choice of neurosis;

Defense mechanisms; Disorganization; Dream; *Ego and the Mechanisms of Defense*, *The*; Face-to-face situation; Fixation; Imago; Libidinal development; Libido; Maternal; “Metapsychological Supplement to the Theory of Dreams”; “Mourning and Melancholia”; Narcissistic withdrawal; Ontogenesis; Paranoia; Psychic causality; Psychic temporality; Psychoses, chronic and delusional; Psychosomatic; Psychotic transference; Representability; Sadomasochism; Self (true/false); Sleep/wakefulness; Stage (or phase); Suicide; *Thalassa: A Theory of Genitality*; Time; Wish, hallucinatory satisfaction of a.

### Bibliography

- Aisenstein, Marilia. (1992). Des régressions impossibles? *Revue française de psychanalyse*, 56 (4), 995–1004.
- Freud, Sigmund. (1900a). The interpretation of dreams. Parts I and II. *SE*, 4–5.
- . (1905d). Three essays on the theory of sexuality. *SE*, 7: 123–243.
- . (1916–17a [1915–17]). Introductory lectures on psycho-analysis. Parts I and II. *SE*, 15–16.
- Winnicott, Donald W. (1958). *Through paediatrics to psycho-analysis*. London: Tavistock.

### Further Reading

- Balint, Michael. (1968). *The basic fault. Therapeutic aspects of regression*. London: Tavistock.
- Blum, Harold P. (1994). The conceptual development of regression. *Psychoanalytic Study of the Child*, 49, 60–76.
- Inderbitzin, Lawrence, and Levy, Steven. (2000). Regression and psychoanalytic technique: A concept’s concretization. *Psychoanalytic Quarterly*, 69, 195–224.
- Sandler, Joseph, and Sandler, Anne-Marie. (1994). Theoretical, technical comments on regression and anti-regression. *International Journal of Psychoanalysis*, 75, 431–440.

---

## REICH, ANNIE (1902–1971)

Austrian physician and psychoanalyst Annie Reich (née Pink) was born on April 9, 1902, in Vienna and died on January 5, 1971, in Pittsburgh, Pennsylvania.

Reich was the third child of Theresa Singer, a primary school teacher, and Alfred Pink, a Viennese merchant; Annie’s father remarried shortly after her mother’s death from influenza, during World War I. Her older brother, Fritz, was killed during the war, and her other brother, Ludwig, emigrated to

Australia in 1939. Reich studied medicine at Vienna University from 1921 and obtained her medical degree in 1926.

In 1921 she began an analysis with Wilhelm Reich, which was interrupted six months later when, in 1922, they were married. Two daughters, Eva and Lore, born in 1924 and 1928 respectively, issued from this marriage. Reich began another analysis with Hermann Nunberg and, years later, with Anna Freud. A member of the Vienna Psychoanalytic Society from 1928, she worked at the proletariat-oriented sex-counseling clinics founded by Wilhelm Reich and Marie Frischauf. After moving to Berlin in 1930, she became involved in the “Kinderseminar” for young, left-wing analysts that was founded by Otto Fenichel, and joined the Berlin Psychoanalytic Society.

In 1933, Reich and her husband separated. Reich emigrated to Prague where she established a practice and helped constitute the new psychoanalytic community there; as a member of the Vienna Psychoanalytic Society, she served as a training analyst until 1938. That year, she married Thomas Rubinstein and emigrated with him and her children to the United States, where she was quickly admitted into the New York Psychoanalytic Society; she served as its president from 1960 to 1962. She was also active in the International Psychoanalytical Association from 1938 until her death.

Reich’s publications include some of the first psychoanalytic works dealing with pedagogical aspects of sexuality, including “Zur Frage der Sexualaufklärung” (On the question of sexual enlightenment) in 1929. In addition, she wrote numerous theoretical and clinical articles, including key papers on counter-transference and female psychology. A collection of her papers was published posthumously in 1973.

LILLI GAST

See also: Reich, Wilhelm.

### **Bibliography**

- Reich, Annie. (1929). Zur Frage der Sexualaufklärung. *Zeitschrift für psychoanalytische Pädagogik*, 3, 98–100.
- . (1973). *Psychoanalytic contributions*. New York: International Universities Press.
- Sharaf, Myron R. (1983). *Fury on Earth: A biography of Wilhelm Reich*. New York: St. Martin’s Press.

## **REICH, WILHELM (1897–1957)**

Wilhelm Reich was an Austrian physician and psychoanalyst. He was born March 27, 1897, in Dobrzycynica, a part of Galicia belonging to the Austro-Hungarian Empire, now a part of Poland. He died November 3, 1957, at the Lewisburg penitentiary in Connecticut. Reich’s parents were assimilated middle-class Jews, who had emigrated after his birth to Jujinetz, in the Ukrainian region of Austria-Hungary. His father owned an extensive tract of land, on which he raised cattle. Two teachers were responsible for the young Reich’s education. At the age of fourteen he entered the local high school in Czernowitz. He was an officer in the Austrian army during the war and began his medical studies upon his return to Vienna.

In 1919 he was admitted to the local psychoanalytic society. In 1921 he married Annie Pink, a brilliant student who became a famous psychoanalyst. Reich had important responsibilities as a teacher and in clinical psychoanalysis, and in 1924 ran a seminar on psychoanalytic technique. At the same time he was working with Austrian socialists. In 1927 he published *The Function of the Orgasm*, which established the existence of a sexual economy focused on the power of the orgasm and genitality. He enrolled in the communist party in 1928 and, the following year, created the Socialist Society of Sexual Advice and Sexual Research. In 1929 he traveled to the USSR, where he familiarized himself with the work of Vera Schmidt, a Russian teacher who made use of psychoanalysis in her school for children.

In 1930 he left Vienna for Berlin, where he continued working to promote communism and psychoanalysis. In 1931 he founded the German Association for a Proletarian Sexual Policy, known as SEXPOL for short, which at one point had several thousand members. In a 1931 brochure, *The Sexual Struggle of the Young*, he promoted a radical liberation of individual behavior. In 1932 he published *The Invasion of Compulsory Sexual Morality*, a sociological study based on the work of the ethnologist Bronislaw Malinowski. Reich lived with Elsa Lindenberg, a dancer who was active in the same cell as he.

In 1933 Hitler was in power and Reich was thrown out of the German communist party. He fled to Denmark, where he published two of his most important works, *Character Analysis* and *The Mass Psychology of Fascism*. In 1934 he settled in Malmö, Sweden, and



founded the *Review of Political Psychology and Sexual Economy*. At the Lucerne Congress a decision was made to exclude Reich from the International Psychoanalytical Association (IPA). He took refuge in Oslo, Norway, where he continued to train psychoanalysts and conducted research on organic electricity. A campaign of defamation—he was referred to as a “Jewish pornographer”—led by a man named Quisling, led Reich to accept the invitation of Theodore Wolfe to move to the United States to teach “character-analytic vegetotherapy.”

He arrived in New York in 1939, rented a cabin in Maine and had several buildings constructed, which he called the “Orgonon.” Here he conducted research, taught, and performed clinical work. It was a period of intense creative activity for Reich. In politics he denounced the “emotional plague,” the source of fascism, and developed the principles for a “democracy of work.” He also became interested in newborns following the birth of his son Peter to his third wife Ilse Ollendorff in 1944. He investigated the problem of cancer and, at the same time, struggled to determine orgone formations in the atmosphere and the cosmos. He successfully practiced vegetotherapy. Preoccupied by the problems of the environment, he explored the Arizona desert (“operation Orop Desert”). He continued to publish and republish at a steady rate: in 1948 *The Function of the Orgasm*, an autobiographical work, and the *Biopathy of Cancer, The Sexual Revolution, and Listen, Little Man*; in 1951 *Ether, God, and Devil*, and *Cosmic Superimposition*; in 1953 *The Murder of Christ and People in Trouble*, published by the Orgone Institute Press.

A campaign of lies and vilification in the tabloid press resulted in Reich being called in for questioning by the police. After refusing to cooperate with the court he was convicted and sent to prison, where he died. A year earlier, as a result of a court decision, nearly all of Reich’s books were burned at the Gansevoort Street incinerator in Manhattan (New York City).

ROGER DADOUN

*See also:* Allgemeine Ärztliche Gesellschaft für Psychotherapie; Berliner Psychoanalytisches Institut; Character; Denmark; Lehrinstitut der Wiener psychoanalytischen Vereinigung; Marxism and psychoanalysis; Norway; Orgasm; Politics and psychoanalysis; Psychic causality; Reich, Annie; Sociology and psychoanalysis/sociopsychanalysis; Wiener psychoanalytische Vereinigung.

## Bibliography

- Dadoun, Roger. (1975). *Cent Fleurs pour Wilhelm Reich*. Paris: Payot.
- De Marchi, Luigi. (1973). *Wilhelm Reich, biographie d'une idée*. Paris: Fayard.
- Reich, Wilhelm. (1933). *Character-analysis; principles and technique for psychoanalysts in practice and in training* (Theodore P. Wolfe, Trans.). New York: Orgone Institute Press.
- . (1933). *The mass psychology of fascism* (Theodore P. Wolfe, Trans.). New York: Orgone Institute Press, 1946.
- . (1940). *The function of the orgasm: Sex-economic problems of biological energy* (Theodore P. Wolfe, Trans.). London: Panther, 1968.
- . (1948). *The cancer biopathy*. New York: Orgone Institute Press.
- . (1988). *Passion of youth: An autobiography 1897–1922*. New York: Farrar, Straus & Giroux.
- Sharaf, Myron. (1983). *Fury on Earth: A biography of Wilhelm Reich*. New York: St. Martin's Press.
- Sinelnikoff, Constantin. (1970). *L'Œuvre de Wilhelm Reich*. Paris: Maspero.

---

## REIK, THEODOR (1888–1969)

Lay analyst Theodor Reik was born on May 12, 1888, in Vienna, and died on December 31, 1969, in New York.

He was the third child of four born to the cultured, lower-middle-class Jewish family of Max and Caroline Reik. Reik’s father was a low-salaried government clerk who died when Theodor was aged 18. Freud became a father figure for the rest of Reik’s life. He attended public schools in Vienna and entered the University of Vienna at the age of 18, where he studied psychology and French and German literature. He received his PhD in 1912, writing the first psychoanalytic dissertation, on Flaubert’s *The Temptation of St. Anthony*. He met Freud in 1910, and two years later became a member of the Vienna Psychoanalytic Society. From 1914 to 1915 he was in analysis with Karl Abraham in Berlin and, with the outbreak of World War I, served as an officer in the Austrian cavalry from 1915 to 1918, seeing combat in Montenegro and Italy and being decorated for bravery.

Following the resignation of Otto Rank, Reik became the Secretary of the Vienna Psychoanalytic

Society. For ten years he practiced in Vienna and began to write so extensively that Freud asked him: “Why do you piss around so much? Just piss in one spot” (Natterson, 1966). Freud wrote “The Question of Lay Analysis” in defense of Reik, who had been prosecuted under the quackery laws of Austria for practicing medicine.

Reik moved to Berlin, where he lived and practiced from 1928 until 1934 and again was a celebrated teacher at the psychoanalytic institute. Fearing the rise of the Nazis, he left for The Hague, where he continued practicing and teaching. During this time his first wife Ella, mother of his son Arthur, died, and he married Marija. Two children were born of this marriage, Theodora and Miriam.

Still fearful of the Nazis, he moved to New York where, as a non-medical analyst, he was denied full membership in the New York Psychoanalytic Society. Reik would not accept the position of research analyst, although he could have made a “charade” of agreement and practiced, as many did. Reik experienced financial difficulties for many periods in his life. He was treated gratis by both Karl Abraham and Freud and for a time he received financial support of 200 marks a month from Freud. After he wrote for help in 1938, Freud wrote back: “What ill wind has blown you, just you, to America? You must have known how amiably lay analysts would be received there by our colleagues for whom psychoanalysis is nothing more than one of the hand-maidens of psychiatry” (Hale, 1995). Reik persevered, however, building a practice, and soon a group of colleagues centered around him and, in 1948, the National Psychological Association for Psychoanalysis was founded.

Reik’s influence on the development of nonmedical analysis in the United States was great. Not only did his many books have a profound effect on the general reading public but his influence through the NPAP (National Psychological Association for Psychoanalysis) and the institutes that split from it suggest that Reik was the major promulgator of non-medical analysis in the United States.

Reik’s psychoanalytic studies include discussions of such writers as Beer-Hofmann, Flaubert, and Schnitzler as well as Shakespeare, Goethe, and Gustav Mahler, to name but a few. He had a unique way of communicating and his writing and conversational style was free associational. His autobiography is to be found in his many works. Among his better known

are: *Listening with the Third Ear* (1948); the monumental *Masochism in Modern Man* (1949); *Surprise and the Psychoanalyst* (1935); his recollection of Freud, *From Thirty Years with Freud* (1940); an autobiographical study, *Fragment of a Great Confession* (1949); applied psychoanalysis of the Bible in *Mystery on the Mountain* (1958); anthropology in *Ritual* (1958); and sexuality in *Of Love and Lust* (1959), *Creation of Woman* (1960), and *The Psychology of Sex Relations* (1961); and music in *The Haunting Melody* (1960).

Toward the end of his life Reik, who grew a beard, resembled the older Freud and lived modestly, surrounded by photographs of Freud from childhood to old age. He died on December 31, 1969, after a long illness.

Natterson says, of Reik: “In many ways, Reik is the epitome of the sensitive aesthete, the pleasure-loving, erotic, highly intellectual, secular Jewish scholar. These characteristics are to be treasured” (Natterson, 1966).

Theodor Reik, disciple of Freud, Secretary of the Vienna Psychoanalytic Society, author of over 20 books and hundreds of papers on literature, music, religion, analytic technique, and masochism, founder of the National Psychological Association for Psychoanalysis (NPAP) in New York, an analyst in four major cities who wrote in a confessional way about his life, loves, failures, and triumphs, occupies a unique place in the history of psychoanalysis.

JOSEPH REPPEN

*See also:* Anthropology and psychoanalysis; Applied psychoanalysis and the interactions of psychoanalysis; “Dreams and Myths”; Evenly-suspended attention; Identification; Judaism and psychoanalysis; Lay analysis; Lehrinstitut der Wiener psychoanalytischen Vereinigung; Music and psychoanalysis; National Psychological Association for Psychoanalysis; Netherlands; New York Freudian Society; Parenthood; *Psychoanalytic Review*, *The Question of Lay Analysis*, *The*; United States.

### Bibliography

- Hale, Nathan G., Jr. (1995). *The rise and crisis of psychoanalysis in the United States: Freud and the Americans 1917–1985*. New York: Oxford University Press.
- Natterson, Joseph M. (1966). Theodor Reik: Masochism in modern man. In Franz Alexander, S. Eisenstein, and Martin Grotjahn (Eds.), *Psychoanalytic pioneers* (pp. 249–264). New York and London: Basic.

## RELATIONS (COMMENSALISM, SYMBIOSIS, PARASITISM)

In his book *Attention and Interpretation* (1970), Wilfred R. Bion conducted a parallel study of the relations between the mystic and the group, between the container and the contained, and between a new idea and the psychism in which it appears. He used the same relations model to describe these three situations with three types of relations: commensal, symbiotic, and parasitic.

Bion uses the relation of the mystic to the group as a springboard for his developments. The mystic, whom he also calls the genius or messiah, is the individual who brings new ideas to the group. He is opposed to the establishment, whose role is to maintain the cohesion and stability of the group. The mystic and the establishment need each other. By maintaining the stability of the group, the establishment enables the advent of the mystic who is engendered by the group to which the mystic gives life (psychic, spiritual, or scientific); the mystic needs the group, therefore the establishment, in order to introduce new ideas to the greatest number of people, for example the benefits of Newton's physics or Freud's psychoanalysis.

But together the group and the mystic maintain relations which, although they include a charge of creativity, also imply a charge of destructiveness. The new idea introduced by the mystic always threatens the existence of the group or one of its sub-groups.

These are the definitions that Bion gives of the three types of relations he describes: "By 'commensal' I mean a relationship in which two objects share a third to the advantage of all three. By 'symbiotic' I understand a relationship in which one depends on another to mutual advantage. By 'parasitic' I mean to represent a relationship in which one depends on another to produce a third, which is destructive of all three" (p. 95).

In the commensal relation there is coexistence on each side of the relation in such a way that each is inoffensive to the other. In the symbiotic relation "there is a confrontation and the result is growth-producing" (p. 78). In the parasitic relation the product of the association destroys the two associated parties; it is a relation that is marked by envy that "cannot be satisfactorily ascribed to one or other party; in fact it is a function of the relationship" (p. 78).

Bion gives different examples of these three types of relations, sometimes drawn from the relations of the mystic and the group, sometimes from the relations of the contained, noted ♂, to the container, noted ♀: "The container," he writes, "is represented by a mouth or a vagina, the contained by a breast or a penis" (p. 95). He illustrates the parasitic, symbiotic, and commensal relations with the example of a man who wants to communicate his annoyance but who is submerged by the emotion and who begins to stutter and becomes incoherent: "Such a failure is the outcome of a 'parasitic' relationship between the contained (or rather, not contained) material and the speech devised to contain it: 'container' and 'contained' have produced a third 'object'—incoherence—which makes expression and the means of expression impossible. In so far as the imaginary episode led to a development of powers of expression and of the personality that strove to express itself, the relationship could be described as symbiotic. 'Commensal' is illustrated by supposing that the episode occurred in an age and society (as in Elizabethan England) in which language had reached a point of development where the ordinary man was inspired to speak it well: that which was to be expressed and the vehicle for its expression profited from the culture to which they belonged" (p. 96).

DIDIER HOUZEL

See also: Bion, Wilfred Ruprecht; Symbiosis/symbiotic relation.

### Bibliography

- Bion, Wilfred. R. (1970). *Attention and interpretation*. London: Tavistock Publications.
- Grinberg, León, et al. (1991). *New introduction to the work of Bion*. Northvale, NJ, and London: Jason Aronson.
- Symington, Joan, and Symington, Neville. (1996). *The clinical thinking of Wilfred Bion*. London: Routledge.

## RELAXATION PRINCIPLE AND NEO-CATHARSIS

The relaxation principle and neo-catharsis is an element in analytic technique that complements the principle of frustration and makes it possible to reach moments of self-hypnotic analytic trance. For Ferenczi this represented technical progress because, along with

the analysis of the transference, this relaxation made it possible to reach very deep zones of the intrapsychic *teratome* consequent to precocious traumatizations (he uses a metaphor from embryology, the teratome being a tumor whose appearance evokes the different stages of embryonic development). A laissez-faire principle establishes the relaxation that is already implicit in the notion of free association.

Ferenczi describes how, with the help of this relaxation and this trust, the patient reaches trance states, transitory fits of veritable hysteria that have the great advantage of “giving a feeling of reality and objectivity that is closer to a real memory.” Moreover, these states of autohypnosis relate back to the old catharsis “long thought to be buried following the development of such successful theoretical constructions.”

In 1929 he read a paper entitled “Progress in Analytic Technique” to the eleventh congress of the International Psychoanalytical Association, held in Oxford. The following year he continued in the same vein with “Principle of Relaxation and Neo-Catharsis.” In his 1929 paper he referred to the work of Reich, Severn, Groddeck, and Simmel, as well as to treatment projects in clinical psychiatry. He also reported a discussion with Anna Freud, to whom he felt very close because of the techniques she used for psychoanalyzing children.

Dating from early psychoanalytic practice, this concept appears to be quite different from what has since come to be known as relaxation. The new catharsis he speaks about is more, as he wrote: “A confirmation from the Unconscious, a sign of our laborious work of analytic construction, of our technique in relation to the resistance and the transference which have finally succeeded in achieving etiological reality.” These two notions deserve their place in modern psychoanalysis, although they imply a new development in traumatic theory in order to explain the grave pathologies observed when prepubescent shock leads to a “passing psychosis,” which later results in the adult patient having the equivalent of an “intrapsychic twin” or “teratome.” Ferenczi progressively came to perceive the “incestuous tendency of repressed adults who don the mask of tenderness.” Two years later he developed these notions in his famous text “The Confusion of Tongues between Adults and the Child,” as well as in his *Clinical Diary*, which did not appear until fifty years later.

Many of the notions expressed here have been increasingly used by psychoanalysts dealing with patients in great difficulty, although some resist the

integration of this dynamic theory. It is worth remembering that a psychoanalyst like Georges Devereux developed the notion of the counter-Oedipus in a comparable vein.

PIERRE SABOURIN

*See also:* Active technique; *Development of psycho-analysis*; Elasticity.

### **Bibliography**

Ferenczi, Sándor. (1930). The principle of relaxation and neocatharsis. *International Journal of Psycho-Analysis*, 11, 428–443.

———. (1949). Confusion of tongues between adults and the child: The language of tenderness and of passion. *International Journal of Psycho-Analysis*, 30, 225–230. (Original work published 1933)

Freud, Sigmund. (1912e). Recommendations to physicians practising psycho-analysis. *SE*, 12: 109–120.

———. (1937d). Constructions in analysis. *SE*, 23: 255–269.

---

## **RELAXATION PSYCHOTHERAPY**

At the urging of eminent neuropsychiatrist Julian de Ajuriaguerra, in the early 1960s a small group of psychoanalysts, all members of the Paris Psychoanalytic Society, attempted with certain patients to employ *autogenic therapy*, a technique inspired by hypnosis. Developed originally by German psychiatrist Johannes Schultz (1884–1970), autogenic treatment involved training a patient to experience well-being and comfort induced by hypnosis, more or less independently of a therapist.

Work with autogenic therapy soon led the group (Michèle Cahen, Jorge García-Badaracco and Marianne Strauss) to develop a psychoanalytic technique that aimed not so much to induce relaxation as to listen to bodily sensations. The observation that each patient experiences their own body in a unique way shifted emphasis toward resistances, perception of body image, and examination of the experience of relaxation itself. The principal psychotherapeutic tool became what Ajuriaguerra (1959) called the *tonic dialogue*. Spontaneous modifications of muscle tone develop in the course of any emotional relationship but almost always go unnoticed. These variations reveal the body's role in distinguishing pleasure-unpleasure and represent the first

“language” of the mother-infant dyad. The goal of relaxation psychotherapy is not primarily to soothe the patient but rather to lead them toward “verbal expression of the states of one’s own body.” (Roux, 1968). Such states, rather than the patient’s fantasies or stories, become the “signifiers” in relaxation psychotherapy.

The work of relaxation therapy takes place along two axes. First of all, it helps the patient to become aware of bodily sensations as experienced in the therapist’s presence, and also helps the patient to formulate descriptions of them and to facilitate verbalization in terms of secondary-process thinking. At the same time, the therapist illuminates the role of the earliest objects in formation of the ego as revealed by bodily reactions in terms of the transference, which is more clearly in evidence. It seems apparent that the therapeutic work can take into account “behavioral” reactions without serious risk of inflicting narcissistic injury. Relaxation therapy produces in the patient a “passive” attitude towards endopsychic functioning and instinctual movements which are ordinarily in a “discharge” mode.

Unlike other similar techniques, relaxation psychotherapy does not employ suggestion. The therapist remains in the patient’s line of sight and seeks to observe “what’s happening with the body” while confining participation to helping the patient describe, in their own words, associated thoughts and feelings. The “tonic-emotional responses” thus discovered are reflected in the relationship with the therapist. This “detour” via the body places the therapist in the position of a primitive transitional object, introducing a third party into the relationship. Therapeutically, this facilitates recapture of secondary-process thinking, development of insight, and integration of behavioral phenomena that can be meaningfully interpreted.

Indications for relaxation psychotherapy include cases with severe underlying weakness in ego structure, whether with evidence of psychosomatic disorder or in patients suffering from narcissistic pathology.

MARIE-LISE ROUX

See also: Group psychotherapies; Psychotherapy.

### **Bibliography**

Ajuriaguerra J. de. (1959). *L'Entraînement psychophysiologique par la relaxation*. Paris: Expansion scientifique.

Lemaire, Jean G. (1964). *La Relaxation*. Paris: Payot.

Roux, Marie-Lise. (1968). L'Expression verbale du vécu corporel. *Revue française de psychosomatique*, 14.

Roux, Marie-Lise, Dechaud-Ferbus, Monique, and Sacco, François. (1994). *Les Destins du corps*. Toulouse: Érès.

Roux, Marie-Lise, et al. (1993). *Le Corps dans la psyche*. Paris: L'Harmattan.

---

## **RELIGION AND PSYCHOANALYSIS**

Religion is a body of beliefs and practices shared by a given social group and connecting it to a higher agency, generally a divinity or divine human. Interestingly, the word *religion* is the same in most western languages, Latin or Germanic. However, the origin of the term has, for more than two thousand years, been the object of an intense debate that is of interest to psychoanalysis. According to the Latin authors Lactantius and Tertullian, the word is related to the Latin verb *religare*, “to reconnect, to bind again.” Religion would, therefore, involve a twofold connection—among humankind and between humankind and God. In Cicero, religion is associated with the verb *relegere*, “to gather.” In this case religion is said to be a gathering together, an interiority, some scruple that prevents or delays action and entails the performance of certain rites. In this sense we agree with philosopher Michel Serres and the linguist Émile Benveniste that the opposite of religion is negligence.

The topic of religion was initially examined by Freud and Breuer in the *Studies on Hysteria* (1895d), where hysteria could be considered a reaction to mental suffering associated with religious doubt. Freud’s first detailed examination of religion, “Obsessive Actions and Religious Practices,” appeared in 1907. The first book in which he discussed religious themes was *Totem and Taboo* (1912–1913a).

Freud saw religion in its collective and individual forms. On the one hand he viewed the church as the prototype of an artificial crowd (as the army), where each individual must love his leader (Christ, for example) as a father and other men as his brothers. Religion helped maintain the cohesion of a human group threatened with disintegration if there was a loss of faith (1921c). On the other hand, he also saw religion, with its ceremonies and detailed rites, as a universal neurosis, where scruples were transformed into obsessive acts.

Religion would contribute to humankind's transition from a natural state to a cultured one through the sacrifice of human drives. But the progress of civilization also implied a return to the irrational and the maintenance of illusions that maintained the individual within the confines of his infantile neuroses (1927c).

The Freudian approach to religion has more to do with anthropology than with theology: Religion is a part of civilization and the discussion of its dogmas is less important than its hold on society and the individual. From this point of view Freud, who claimed to be an atheist, had to confront the criticisms of his friend, Pastor Pfister, along with those of his former student Carl Jung. Moreover, Freudian conceptions of religion relied on the knowledge available during the early twentieth century, which has since often been challenged by the findings of archeology and epigraphy. Thus the character of Moses leading the people of Israel through the desert and out of Egypt in *Exodus*, a figure magnified by Freud, seems in the early twenty-first century to have more to do with myth than with history. And, unlike Jung, Freud rarely made reference to the religions of the Far East, which are so unlike Hellenistic and Middle Eastern cultures.

ODON VALLET

*See also:* Beirnaert, Louis; Belief; Certeau, Michel de; Choisy, Maryse; "Claims of Psychoanalysis to Scientific Interest"; *Future of an Illusion, The*; Ideology; Illusion; Judaism and psychoanalysis; Jung, Carl Gustav; Lacan, Jacques-Marie Émile; *Moses and Monotheism*; Mysticism; Oceanic feeling; Philippon Bible; Rite and ritual; "Seventeenth-Century Demonological Neurosis, A."

### **Bibliography**

- Freud, Sigmund. (1907b). Obsessive actions and religious practices. *SE*, 9: 115–127.
- . (1912–1913a). Totem and taboo. *SE*, 13: 1–161.
- . (1921c). Group psychology and the analysis of the ego. *SE*, 18: 65–143.
- . (1927c). The future of an illusion. *SE*, 21: 1–56.
- . (1939 [1934–1938]). *Moses and monotheism: Three essays*. *SE*, 23: 1–137.

## **REMEMBERING**

The term *remembering* designates the specific psychic action of producing a memory and is to be distinguished

from reminiscences, flashbacks, and all other elements of the past that might be seen to constitute other types of representation. Freud, together with Josef Breuer, introduced this notion in their preliminary communication (1893a) as part of their cathartic therapy and Freud's initially trauma-based theory of hysteria. Freud stressed that simple recollection of memories with no accompanying affect, and so reduced to pure ideas, would have no therapeutic value. Remembering that is efficacious, and therefore of interest to psychoanalysis, involves the subject's reliving traumatic events with all their original affective intensity. Here Freud, while also stressing conditions of therapy, was already distinguishing purely narrative ideas that have affective energy discharged and that remain blocked in a split-off part of consciousness.

The recollection of memories in treatment introduced the difficulty of distinguishing between childhood memories and "screen memories" (1899a), despite certain clinical characteristics pertaining to the latter. Freud noted that the disparity between screen memories and other memories from childhood remained ultimately problematic. Did conscious screen memories originate in childhood or simply relate to it?

This question, raised as early as 1899, remains very much alive, because there is no guarantee that the recollection of even the most authentic memories travel a direct route from the past of childhood to the present of analytic treatment, and the total reliability of such remembering is certainly open to doubt. Inevitably, childhood memories are subject to the happenstance experience of the subject, leading to unconscious distortions, infidelities, maskings, false leads, and so on. The analyst who maintains that such memories are genuine, even those with the best claim to being authentic, is either naive or is laboring under a narcissistic illusion of omniscience.

In the area of remembering, psychoanalysis has to defend its sphere of authority by distinguishing itself from neurobiological, neuropsychological, and cognitive approaches to memory. Remembering remains a key element of psychoanalytic treatment. As in other relations that psychoanalysis has with proximate scientific disciplines, the issue is generally one of a cross-disciplinary misunderstanding, which it would be proper to resolve. This is what motivated Jean Laplanche to evoke Freudian pseudo-biology, pseudo-neurology, and pseudo-psychology. Unconscious

phenomena, the area specific to psychoanalysis, inevitably pervert, or at least distort, the various types of positive knowledge about humans.

Remembering in psychoanalysis can only be pertinent, therefore, when such remembering imitates the mechanisms that govern the recall function of memory, whose incredible complexity contemporary science is just beginning to plumb. Conversely, because of the necessary positivism of its project, the scientific approach to remembering cannot account for the negativism and emptiness in the psyche's dialectic between meaning and meaninglessness. Everything—from birth to death—that constitutes the enigmatic and singular design of an individual's destiny escapes, for the most part, from the individual's consciousness. Hence, there are limits to remembering.

To see how remembering functions in analysis, it is appropriate to chart a history of the aims of analytic treatment:

- The original memory model of psychoanalysis aimed at recollecting a childhood past that was buried but is likely to be brought to light.
- A subsequent model yielded increasingly to structures not subject to the internal history of the subject's life (the death drive, the Oedipus complex, repetition), in other words, to elements introduced by Freud in his second conceptualization of the psychic apparatus and to advances made in psychoanalysis since around 1930. Because psychoanalysis depends on the chance elements of the transference, this substantially relativized hope for a "spontaneous tendency towards a return of the repressed." As a result, the unrepresentable, the repetition compulsion, and various forms of psychic breaching have taken on a prominent role in the transference (Baranès).
- Finally, since the 1970s, psychoanalysis has been extending and openly accepting its own theoretical and practical divisions.

Remembering should be regarded essentially as reconstructing a certain historical truth together with ceding to what is sometimes referred to as "structural truth" (truth concerned with mental organization). Remembering and the freedom to rediscover one's own history, along with the de-centering that this entails, carves out a space that accords with some modulations of fantasy play and with the necessary mythology of origin. Analytic treatment—woven from

the memorable, the infantile, the repeatable, while encountering limitations to meaning and meaninglessness and the absence of temporal references—would be lost if the analyst's constructions and interpretations of the transference were not subordinate to the analysand and his freedom.

An individual engages in analytic treatment to effect change. An assemblage of memories, even an organized one, that does not benefit from the work of composition and that does not take into account the inherent constraints of the psychic apparatuses, whether grouped or corporeal, would be nothing but a dead letter, destined to be neither interpreted nor recreated. It is the fabric of the transference that facilitates, for both analysand and analyst, the energetics of transformation. As a result, while memories and historical working through might not be enough in themselves to move the analysis forward, they are nevertheless a *sine qua non* of analysis. In this respect, individuals are like nations: a community that has forgotten its history is condemned to servitude.

CLAUDE BARROIS

*See also:* Abstinence/rule of abstinence; Acting out/acting in; Active technique; Amnesia; Change; Construction/reconstruction; Déjà-vu; *Development of Psycho-Analysis*; Ego states; Forgetting; Memory; Narcissistic elation; Relaxation principle and neo-catharsis; "Remembering, Repeating and Working-Through"; Reminiscences; Repression, lifting of; Resistance; Silence; Transference; Word-presentation.

### **Bibliography**

- Baranès, Jean-José. (1990). Être à la fois mémoire et provocateur. In Société psychanalytique de Paris (Ed.), *La psychanalyse: Questions pour demain*. Paris: Presses Universitaires de France.
- Diatkine, René. (1990). Remémoration, prise de conscience. *Revue française de psychanalyse*, 54 (4), 911–921.
- Freud, Sigmund. (1899a). Screen memories. *SE*, 3: 299–322.
- Freud, Sigmund, and Breuer, Josef. (1893a). On the psychological mechanism of hysterical phenomena: Preliminary communication. *SE*, 2: 1–17.
- Laplanche, Jean. (1987). *Nouveaux fondements pour la psychanalyse*. Paris: Presses Universitaires de France.
- Widlöcher, Daniel. (1994). Psychanalyse et processus de changement. In his *Traité de psychopathologie*. Paris: Presses Universitaires de France.

## “REMEMBERING, REPEATING AND WORKING-THROUGH”

Written and published in 1914, “Remembering, Repeating and Working-Through” clearly established Freud’s position on analytic technique, in which the cathartic method had yielded to the associative method. It thus deserves notice as one of the few technical writings to complement the great metapsychological edifice of 1915.

Freud begins the essay by citing the cathartic method, without doubt in order to mention how much he owed to it for having “acquainted him with certain analytical processes,” but above all so that the reader could recognize how much technical progress had been made with the new associative method. During this period, 1914–1915, treatment began to involve real psychic work for the patient for whom passive hypnosis is no longer clinically effective. The goal of this effort is to *remember*, “to fill in gaps in memory,” as Freud states, and to “overcome resistances due to repression” (p. 148). The growing complexity of analytic technique was opposed to the simplicity of the hypnotic technique, which responded only to the simplest form of remembering.

This required that forgetting, a psychic fact that had been previously thought to be negligible, be reconsidered in all its amplitude and complexity. “Impressions” and “experiences” (p. 148), insofar as they have a rapport with forgetting, were opposed by Freud to psychic reality, that is, to “phantasies, processes of reference, emotional impulses, [and] thought connections” (p. 148). From this point on, memory, a favorite theme of Freud’s since his work on aphasia, was to become an extensive subject for investigation. Yet remembering is not a straightforward process; thus, while the encounter between analyst and analysand might stimulate the repetition of the past, it does not always take the form of a memory, but might reside also in actions.

Repetition as action rather than as memory led Freud to examine the links between the three concepts of transference, repetition, and resistance. Transference is simply a “piece of repetition” (p. 151), and repetition is only the “transference of the forgotten past” (p. 151) onto the analyst but also onto “all the other aspects of the current situation” (p. 151). Freud then identified a further type of repetition, “the compulsion to repeat,” which replaced the “impulsion to remember” (p. 151) exposed by the analyst and which

demonstrated the powerful resistance to analysis mounted by the defenses. Respect for this resistance, and an acknowledgement of it in analytic technique, is necessary if the work of analysis is to comprehend the full extent of the psychic apparatus; hypnosis, conversely, totally suppresses this resistance. The psychoanalyst’s interest is in the contents of memory and the meaning that he can attribute to them, but he must remain particularly attentive to the means by which these memories are recalled.

The handling of the transference then becomes an essential task for the analyst while the treatment is underway. Too intense an amorous transference, or, conversely, a hostile transference toward the analyst, will bolster the resistance, causing the analysis to slide into repetition (as act). In this case, repression is the customary defense mounted by the resistance, which deprives the analysand’s thought of memorable ideational content and displaces the corresponding quota of affect onto the act.

It is clear in this article that the instinct’s quantitative potency can be made to signify so long as resistance to it is not excessively powerful, an *a priori* structuring, then, of the psychic apparatus around the transformation of instincts. Freud also provides some technical advice on how to advance the treatment towards a successful conclusion. Some of these recommendations are represented in the figure of the analyst and the analysand struggling against a common enemy: a state of morbidity. Freud wrote that the task of the analyst consists in treating the illness “not as an event of the past, but as a present-day force. . . . which consists in a large measure in tracing it back to the past” (p. 151). This approach should lead to “a change in the patient’s conscious attitude to his illness. . . . [and allow him to] find the courage to direct his attention to the phenomena of his illness.” (p. 152); so that it can ultimately “become an enemy worthy of his mettle” (p. 152). So long as the analyst continues to observe “the fundamental rule of analysis” (p. 155), neither the framework of the analysis nor its influence on the transference will be affected.

Freud admits that it is not always easy to derive ideational mnemonic content from acting out. Thus near the end of the text he writes that occasionally, “it is bound to happen that the untamed instincts assert themselves” (p. 153–154), the effects of which can be witnessed in the repetitive act whereby “the bonds which attach the patient to the treatment are broken”



(p. 154), or through other instances of negative therapeutic reaction. Freud advised that in these difficult cases “The main instrument [...] for curbing the patient’s compulsion to repeat and for turning it into a motive for remembering lies in the handling of the transference. We render the compulsion harmless and indeed useful, by giving it the right to assert itself in a definite field. We admit it into the transference as a playground in which it is allowed to expand in almost complete freedom” (p. 154). In order to transform the morbid state into “an artificial illness, which is at every point accessible” (p. 154) to analytical intervention, the analyst should not rely only on the “working-through” of the patient, but rather on an extension of his knowledge of metapsychology, as well as an acquaintance with aspects of his own character that might pose an obstacle to the cure.

Freud’s conception of the psychic apparatus in 1914 was still based on the first topography; however, in order to properly account for treatments whose virtually unassailable resistances obstruct the progress of the treatment, by mobilizing an entire procession of negative phenomena, he had to wait for the introduction of the “death drive” and the further complication of the psychic apparatus by the second topography.

Thus, while Freud spoke of rendering “the compulsion harmless, and indeed useful, by giving it the right to assert itself in a definite field” (p. 154), he ended the article on a less optimistic note only a few lines later. The demonstration to a patient of their resistance is often not enough to overcome it, and indeed frequently intensifies it, which is why Freud stressed the importance of “working in common” (p. 155) and the continuation of analysis, even if the endeavour eventually becomes “a trial of patience for the analyst” (p. 155). This advice, in a form more suited to the realities of the analytic treatment, was reiterated and endorsed by the theoretical developments introduced in his 1937 article “Analysis, Terminable and Interminable.”

Freud’s emphasis on the repetition compulsion from 1914 onwards might make it the precursor of the repetition compulsion of 1920, the consequence of an instinctual dualism between the life instincts and the death instinct. The compulsion to repeat of 1914 differs from that of 1920 in that the former is under the sway of the pleasure principle. In *Beyond the Pleasure Principle* (1920g), Freud identified compulsive instinctual phenomena that repeated psychic formations foreign to the pleasure principle, thus placing the repe-

tion compulsion of 1920 in an entirely different relationship to the pleasure principle.

RENÉ PÉRAN

*See also:* “Analysis terminable and interminable”; Displacement of the transference; Remembering; Repetition; Silence; Transference neurosis; Working-through.

### Source Citation

Freud, Sigmund. (1914g). Errinern, Wiederholen und Durcharbeiten (Weitere Ratschläge zur Technik der Psychoanalyse, II). *Internationale Zeitschrift für ärztliche Psychoanalyse*, 2, 485–491; Remembering, repeating and working-through. *SE*, 12: 147–156.

### Bibliography

Cournut, Jean. (1991). *L’Ordinaire de la passion*. Paris: Presses Universitaires de France.

Guillaumin, Jean. (1983). *Psyché*. Paris: Presses Universitaires de France.

Mijolla-Mellor, Sophie. (1992). *Le Plaisir de pensée*. Paris: Presses Universitaires de France.

---

## REMINISCENCES

Reminiscences are special forms of memory that rise up from the past, confused, vague, involuntary, distorted, or rendered unrecognizable by unconscious mental activity. They also entail a relaxation of the psychic apparatus such that the subject does not necessarily recognize these “rememberings” as belonging to his own past.

The concept entered into the field of psychopathology in Sigmund Freud and Josef Breuer’s “Preliminary Communication” (1893a). The phrase “*der Hysterische leidet grösstenteils an Reminiszenzen*” (“the hysteric suffers for the most part from reminiscences”) represents both a break with earlier psychopathology and an introductory maxim for psychoanalysis. This phrase, linking hysteria and reminiscence, introduced a new field of exploration by showing that hysteria consists in alterations of remembering, that is, the concrete affect of the past that will be lastingly expressed in symptoms.

The concept of reminiscence, like its use in psychoanalysis, turned out to be both incontrovertible and difficult to identify. This difficulty has to do with

the variety of the relationships between patients and analysts and their own pasts, their histories, and conceptions of reality, as well as the appearance, from 1896 until now, of new concepts and ideas. Given growing experience with therapy and theoretical research, these factors require continued attention to terminological accuracy. In 1996, following the refocusing of interest on reminiscence, the notion seemed to be more difficult and problematic to identify because of its increasingly generalized nature.

Initially the use of the term *reminiscence* referred to both the nature of the psychogenesis of hysteria and the effectiveness of cathartic therapy. Freud and Breuer associated hysterical symptoms with old psychic traumas whose memory had remained unconscious—in a space that had been split off from consciousness; in their attempt to transform these pathogenic reminiscences into true memories, the therapists showed they were capable of suppressing both the symptoms and healing the splitting from consciousness that had produced them. This, together with the notion of pathogenic psychic trauma, prefigured the notion of the unconscious.

The different attempts to model the psychic apparatus (homeostatic models, memory models, linguistic models) were so many constructions needed to articulate different realities: infantile reality and its effects, sexuality, dreams, the container and content of psychoanalytic therapy. Reminiscences, which are inherent in all the analyst's material, appear as the veiled echo of a reality that is itself problematic. The products of constructions and interpretations, these are situated between a so-called “mystic writing pad” or primal writing surface, and the decentering of a subject who reappropriates their own history.

The clearest manifestation of reminiscences, which extends beyond the Freudian context of 1893, is found in the psychotraumatic syndromes or “traumatic neuroses.” Here the patient suffers from an implacable repetition of the traumatizing situation in dreams and in the production of flashbacks, which are either reproduced with cinematic accuracy or distinctly transposed. This pathology, which is fairly common and sometimes appears during the analysis of a “classic” neurosis, closely resembles Freud and Breuer's 1893 discovery: the metaphor of the internal foreign body and the irruption of mnemonic material that does not consist of memories but of images of an almost persecutory past. It is extremely difficult to transform these reminiscences

into memories. Freud and Breuer themselves noted that the psychic trauma did not only involve Jean Martin Charcot's traumatic hysteria, but the traumatic neuroses more generally. In the early twenty-first century, the concept of reminiscence can provide psychoanalysis with an opportunity to return to the investigation of “psychic trauma” with greater accuracy.

CLAUDE BARROIS

*See also:* Amnesia; Cathartic method; Cinema and psychoanalysis; *Five Lectures on Psychoanalysis*; Forgetting; Hysteria; Lie; Memory; *Neurotica*; Psychic reality; Remembering; Repression, lifting of; Seduction; Scenes of seduction; *Studies on Hysteria*; Symbolic, the (Lacan).

### Bibliography

- Barrois, Claude. (1988). *Les Névroses traumatiques*. Paris: Dunod.
- Dayan, Maurice. (1995). *Inconscient et Réalité*. Paris: Presses Universitaires de France.
- Freud, Sigmund. (1925a [1924]). A note upon the “mystic writing pad.” *SE*, 19: 225–232.
- Freud, Sigmund, and Breuer, Josef. (1893a). On the psychical mechanism of hysterical phenomena: Preliminary communication. *SE*, 2: 1–17.
- Laplanche, Jean. (1981). *Problématiques IV, L'Inconscient et le Ça*. Paris: Presses Universitaires de France.

---

## REPARATION

Reparation is a form of sublimation connected, in the depressive position, with putting right damage done to good objects.

The pain of depressive anxiety (or guilt) starts as a deeply persecuting demand for a punishment—the talion law of an eye-for-an-eye and a tooth-for-a-tooth. As this position is worked through, new feelings (*pining*, Melanie Klein called it) appear towards the object, and are associated with specific impulses to repair the damage done by aggressive phantasies or acts. Development in the depressive position along this axis depends on the capacity to sustain a feeling of love towards the object despite the impulses of hating and, in phantasy, wanting to attack the good object.

Love takes the form of a kind of penance or atonement to a loved one, creating a mixture of sadness, regret, and activity. This is reparation.

In the characteristic manic defenses the ego takes up a position in which the object is degraded, so that damage to it becomes a matter of indifference. At first reparation may be strongly colored by these defenses (manic reparation) and then reparation is not yet based on regret but is a demonstration of a strength and energy superior to that of the object.

The depressive position is founded primarily on the relations to the internal good object, and reparation is a means of securing it. Though reparation may often be directed to external objects, the latter represent the internal object to which the ego is dedicated.

Like sublimation, reparation is deeply dependent on the social context to provide useful directions for the effort to be channeled. Klein described reparation as a powerful impetus to creativity (1935). Aesthetic achievements are examples of the most touching and loving devotions to recreating the beauty of the loved object (Segal, 1991). Reparation without the sadness and regret betrays itself in a technical perfection of prettiness, distinct from beauty. Hanna Segal (1991) has greatly expanded the understanding of the Kleinian views on the aesthetic process based in reparation; and to some extent her descriptions of the aesthetic process compliment Donald Winnicott's theory of the aesthetic object (as transitional object). As a further addition to the psychoanalytic theory of aesthetics, Donald Meltzer has pointed to the place of the infant's primary "worship" of the breast, and of the parental creative couple, conflicted though that is.

Sublimation is a similar drive toward the use of libido in acceptable ways, though it is conceived in terms of the quantitative distribution of the libido while reparation is in terms of object-relations. Because it is an attempt to repair the effects of aggressiveness, reparation also links with undoing.

Reparation might be included within the term *sublimation*. However, reparation is not the result of desexualized and rechanneled libido. Instead it is the mobilization of the libidinal impulses in the context of a relationship with an object (especially an internal one) to contest the aggressive ones.

ROBERT D. HINSHELWOOD

*See also:* Cruelty; Depression; Depressive position; Gift; Melancholia; Schizophrenia; Splitting; Splitting of the object.

### **Bibliography**

- Heimann, Paula. (1942). Sublimation and its relation to processes of internalization. *International Journal of Psycho-Analysis*, 23, 8–17.
- Klein, Melanie. (1935). A contribution to the psychogenesis of manic-depressive states. *International Journal of Psycho-Analysis*, 16, 145–174; reprinted 1975 in *The Writings of Melanie Klein* (Vol. 1, pp. 262–289). London: Hogarth.
- Klein, Melanie, and Riviere, Joan. (1937). *Love, hate and reparation*. London: Hogarth.
- Segal, Hanna. *Dreams, phantasy, and art*. London: Institute of Psychoanalysis-Routledge.

---

## **REPETITION**

A characteristic expression of unconscious psychic processes, repetition drives the subject, more or less regularly, but inflexibly, to reiterate systematically certain experiences, thoughts, ideas, and representations.

Discovering and accounting for repetition opened up one of the most fertile areas of study for Freudian psychoanalysis. Whereas others emphasized hereditary, physiological, traumatic or circumstantial causes, Freud stressed that what was involved was the automatic repetition of memories and experiences that are no longer conscious, according to modalities that vary with the circumstances and individual case. The technique adopted from the time of *Studies on Hysteria* (1895) favored placing this process of repetition within the special framework of the psychoanalytic relation, wherein the idea or affect that was blocked from conscious manifestation could be expressed (catharsis). Freud pointed out, all the same, that if the memory was blocked in the unconscious, this was because it was comprised of elements that had taken the turn of "deferred action." Consequently, repetition does not mean similitude, which contrasts it from the symptom properly speaking, particularly the obsessional symptom, where it is repeated as such.

The notion of *repetition* was originally introduced by Karl Groos, for whom *recognition* was the basis of ludic and aesthetic pleasure, and also by Gustav Fechner, who defined pleasure as the result of an economy of psychic effort, leading to a lowering of tension.

Repetition provokes the return of the already-known, “reunion with the object” and the tranquility of a satisfaction whose experience is deeply rooted in the psyche. This can take two possible directions: regression pure and simple, which, when it is engaged, imposes the repetition of the same on the entire psychic life; or conversely, that of an alternating rhythm of falling into a rut and coming out of it, which becomes the indispensable basis for new experiences.

In the subsequent work of Freud, there were two distinct periods, separated in 1920 by *Beyond the Pleasure Principle*. Until this time, when repetition was mentioned, in various contexts, it was always in the same sense and often conjoined with other notions such as recall, abreaction, construction, and working through. After 1920, it almost never came up again except in the form of a “repetition compulsion.” Here the focus will be, essentially, on repetition of the first period, and its extensions.

In the first meaning of the term, repetition was equivalent to reiteration. In *The Interpretation of Dreams* it was a significant primary process: “The temporal repetition of an act is regularly shown in dreams by the numerical multiplication of an object” (1900a). In *Jokes and Their Relation to the Unconscious* (1905c), it was the source of the comic, by reason of the economy of concentrated effort and the effect of pleasure thus obtained. With a child this pleasurable effect of repetition is quite evident. But for an adult, when something is repeated, what was first pleasurable arouses anxiety and a feeling of abnormality, especially when the repetition emerges from an encounter or an experience where it was least expected. Freud cited a few examples of this in “The ‘Uncanny’” (1919h), such as the repetition of the same number, the same place, or the multiplied encounter of the same face—all of which can become the source of considerable anxiety. Freud was known to harbor quasi-superstitious feelings about certain times of the year, the repetition of numbers, or about coincidences. In his *Leonardo da Vinci and a Memory of His Childhood* (1910c), he called a repetition that occurred in the context of the death of the father *perseveration*, adding that “It is an excellent means of indicating affective colour.”

In his article “Remembering, Repeating and Working-Through” (1914g), Freud described the role of repetition in the analytic cure, considerably narrowing its significance by linking repetition to acting out. Repetition matters only when the subject “does not remember anything

of what he has forgotten and repressed, but *acts* it out” (p. 150). In which case, “We soon perceive that the transference is itself only a piece of repetition” (p. 151). This accounts for the rule that no serious decision should be made in the course of the analysis. Insofar as it is only purely and simply repetition, transference is a resistance, since it is marked by the anachronism of repeated contents and aims to disguise the effects of deferred action.

In clinical practice, the most typical example of this is the fate neurosis, which produces ineluctably the translation of memories or repressed events into acts, a process discussed in “Remembering, Repeating and Working-Through” (1914g). In transference neurosis, the repetition intervenes basically on the level of affects or representations, which constitute undeniably for Freud evidence of early repressed pleasures that the subject has not been able to renounce, to the point that his thoughts are invaded by the repetitions, or he becomes fixated and obsessed. The problem here then is to limit the fascination they exert, so as to make it possible to break free of them, which can only be done in the framework of a transference-neurosis type of repetition—but one made flexible by means of interpretation. With perversion, the repetition is focused essentially on the scenario, the practice or means utilized in the search for pleasure, which leads to stereotyping and systematizing.

Daniel Lagache placed much emphasis on the role of repetition in the transference: “In the course of the sessions of psychoanalysis, as in the course of life, the patient draws from his repertoire of habits,” and on this basis, “the liquidation of the transference should be understood as a liquidation of the transference neurosis, that is to say of neurotic repetitions, inadequate for present-day reality.” This assimilation of “repetition” with “inappropriate” characteristics was echoed a few years later by Ralph Greenson (1967). Jean Laplanche criticized this conception of repetition, which he considered too adaptationist, opposing it to a repetition such as is manifested in “full transference,” which is a positive repetition of infantile images or relations—or the kind of repetition such as is behind the “hollow transference,” whereby the infantile repeated relation rediscovers its enigmatic quality, with meaningful questions surging to the surface when this occurs (1987).

In childhood the role of repetition is decisive. Through the first articulation of meaningful phonemes, primitive gestures or initial mimicry, it results in the establishment and gradual reinforcement of

signs, rhythms, and habits that will shape the being of the subject, his physiognomy and rapport with the world.

However, in the form of tics, stereotypes, stammering, etc., repetition signals real blockages; but when repetition turns into swayings, rictus, suckings, cries, and so on, it constitutes a valuable sign of early autism (Leo Kanner) or of anaclitic depression (René Spitz). These repetitions are evidence, in effect, of a progressive withdrawal of the child into a regressive internal world where his tendency is to lose himself. In this sense, childhood is a privileged period for observing the relation to others and situating oneself: as long as the other person remains a partner, there are progressive clarifications that result in a relatively stable habitus, one that it is possible to build on. However, when the partner is distant, unknown, mysterious, enigmatic, and silent, then sometimes obstructions and inhibitions occur that require external intervention. On the other hand, when real stereotyping ensues, it can only mean that the other has been confused with an internal object.

Repetition plays an especially important role in all activities centered on sublimation, and consequently in literary or artistic creation. In analyzing the *Gradiva* of Jensen (1907a), or meditating over *Leonardo da Vinci and a Memory of his Childhood* (1910c), Freud isolated a form of repetition that not only becomes renewal, but also metamorphosis or creation: in the case of *Gradiva* there was a risk of alienation from reality, while repetition clearly allows, in the case of Leonardo, for a very special way of working with reality. Freud's intuition was applied later to the subject of music, where repetition becomes rhythm, which is probably its source, engendering irreplaceable drive pleasures and satisfactions at the deepest levels of psychic functioning (Guy Rosolato).

GÉRARD BONNET

*See also:* Repetition compulsion.

### **Bibliography**

Freud, Sigmund. (1914g). Remembering, Repeating and Working-Through (Further recommendations on the technique of psycho-analysis II). *SE*, 12: 145–156.

Rosolato, Guy (1993). *L'écoute musicale comme méditation*. In *Pour une psychanalyse exploratrice de la culture* (pp. 187–197). Paris: Presses Universitaires de France.

## **REPETITION COMPULSION**

Repetition compulsion is an inherent, primordial tendency in the unconscious that impels the individual to repeat certain actions, in particular, the most painful or destructive ones. The repetition compulsion occupies a significantly more prominent role in French psychoanalysis than in North American psychoanalysis.

Freud introduced this notion in chapters 3 and 4 of *Beyond the Pleasure Principle* (1920g), making it one of the new foundations of his theory. In the first lines of chapter 4 he presented this idea as being a “speculation, . . . an attempt to follow out an idea consistently, out of curiosity to see where it will lead” (p. 24). At the same time, he stressed that he wanted to base it solidly on analytic experience, especially that of treating “traumatic neurosis” (p. 24). Just as the unconscious mind reacts to an external trauma by repeating it—a paradox, since the trauma is a frightening experience—the conscious mind resorts to repetition when unpleasurable unconscious contents surface and threaten the equilibrium of the ego as a whole. Repetition compulsion is thus initially a defense, an attempt to bind, assimilate, and integrate undesirable experiences that are incompatible with other experiences. Freud saw this as “a function of the mental apparatus which, though it does not contradict the pleasure principle, is nevertheless independent of it and seems to be more primitive than the purpose of gaining pleasure and avoiding unpleasure” (p. 32). Thus “excitations from within . . . often occasion economic disturbances comparable with traumatic neuroses” (p. 34).

Freud considered the repetition compulsion as a largely dominant “universal attribute . . . of organic life in general” (p. 36). Modifications and development take place only because external factors regularly force the living organism to adapt to new life conditions. In this regard, he wrote, “The aim of all life is death” (p. 38). In “ever more complicated *détours* . . . these circuitous paths to death . . . would thus present us to-day with the picture of the phenomena of life” (p. 39). Unconscious instincts are also subject to this law, this aim of life, and would be completely submerged in repetition were it not for the environment and its countless demands, on the one side, and sexuality and its potentialities, on the other. “These germ-cells, therefore, work against the death of the living substance and succeed in winning for it what we can only regard as potential immortality” (p. 40). In human

beings, these cells were posited as being at the source of what Freud later called the “life instinct,” while the compulsion to repeat, which is primary, is associated with the death instinct.

Freud thereafter continually tried to give a more precise account of this initial insight. The phenomenon of positive transference helped substantiate the idea of a repetition compulsion, which could prove stronger than the pleasure principle, he explained in “Remarks on the Theory and Practice of Dream-Interpretation,” (1923c [1922]). In “An Autobiographical Study” (1925d [1924]), Freud wrote that “the essentially conservative character of instincts is exemplified by the phenomena of the *compulsion to repeat*” (p. 57). In *Civilization and Its Discontents* (1930a [1929]), he explained that the repetition compulsion involves a resistance of the id. And in 1930 he explained why he preferred the term *compulsion to repetition automatism*.

In his late work, Freud emphasized the destructiveness of the repetition compulsion. In “New Introductory Lectures to Psychoanalysis” (1933a [1932]), he wrote, “And now the instincts we believe in divide themselves into two groups—the erotic instincts, which seek to combine more and more living substance into ever greater unities, and the death instincts, which oppose this effort and lead what is living back into an inorganic state. From the concurrent and opposing action of these two proceed the phenomena of life which are brought to an end by death” (p. 107). Repetition compulsion thus became synonymous with destructive impulses. Finally, Freud associated it with primary masochism, in which the subject turns violence against himself and subjugates his libido to it, endlessly repeating certain damaging patterns based on experiences rooted at the deepest levels within the self. He theorized that this is a way of tolerating feelings of guilt. The individual manifests a tendency to destroy and suffer, which brings with it feelings of overwhelming satisfaction, all of which are vestiges of a time when the individual did not yet have a sense of reality. In the famous text “Analysis Terminable and Interminable” (1937c), Freud revealed his greatest pessimism noting that instead of “permanently disposing of an instinctual demand [through analysis].... we mean something else, something which may be roughly described as a ‘taming’ of the instinct” (p. 224–225)

As on the dichotomy between the life and death instincts, psychoanalysts have been divided on the issue of repetition compulsion. As a result, it has been reinterpreted in several ways. Among the most influential

interpretations is that of Jacques Lacan (1978), who saw repetition compulsion as one of the four major concepts of psychoanalysis, along with the unconscious, transference, and the instincts. He used it as the basis for his distinction between *jouissance* (enjoyment) and pleasure, with *jouissance* being situated “beyond the pleasure principle” as the desired result of repetition of the worst carried to its extreme. Jean Laplanche, by contrast, emphasized that the “repetition compulsion and the death instinct are not at all synonymous”: it is the message of the Other as such that is traumatic, and repetition is the first way of giving it meaning.

The concept of the repetition compulsion turned Freudian theory on its head. It introduced the death instinct, opened the way to the second theory of the instincts, and led to modifications in clinical practice and analytic technique that are still going on in the early twenty-first century. Analysts no longer focus on deciphering slips of the tongue or dreams, or on resolving a particular symptom, but instead try to find ways to halt repetitive behavior patterns by opening up diversionary pathways for them. From a theoretical point of view, the evolution of the notion of repetition compulsion and the constant shifts it underwent in Freud’s thinking has received far more consideration than one would expect. In the beginning, the main role of the repetition compulsion was to account for the psyche’s conservative tendencies, its reactions in the face of anything that might invade it. Only at a second stage did Freud emphasize the compulsive, systematic, instinctual aspects of the repetition compulsion and bring out its fundamentally destructive side. This shift is problematic. To get beyond the resulting contradiction, which emerges in the opposing positions of Lacan and Laplanche (1980), one must return anew to one of Freud’s statements in the metapsychological articles of 1915, according to which all instincts are fundamentally active, willed, and enacted by the subject alone. And one must note in addition that the subject exists in relation to others and is the product of relationships. Subjects repeat what they internalized during their earliest relationships, in order to actively exploit this initial lived experience by all means at their disposal. This repetition turns into automatism pure and simple and becomes destructive when it runs up against some of life’s obstacles. Then repetition is completely beyond the control of the subject, who is held hostage to it.

GÉRARD BONNET

See also: Automatism; *Beyond the Pleasure Principle*; Compulsion; Death instinct (Thanatos); Jouissance (Lacan); Obsession; Protective shield, breaking through the; Punishment, dream of; Repetition; Repetitive dreams; Trauma.

### Bibliography

- Freud, Sigmund. (1920g). *Beyond the pleasure principle*. *SE*, 18: 1–64.
- . (1923c [1922]). Remarks on the theory and practice of dream-interpretation. *SE*, 19: 107–121.
- . (1925d [1924]). An autobiographical study. *SE*, 20: 1–74.
- . (1930a [1929]). Civilization and its discontents. *SE*, 21: 57–145.
- . (1933a [1932]). New introductory lectures on psychoanalysis. *SE*, 22: 1–182.
- Freud, Sigmund. (1937c). Analysis, terminable and interminable. *SE*, 23: 209–253.
- Lacan, Jacques. (1964). Position de l'inconscient. In his *Écrits*. Paris: Seuil, 1966.
- . (1978). *The seminar of Jacques Lacan*. Book 11: *The four fundamental concepts of psychoanalysis* (Alan Sheridan, Trans.). New York: W. W. Norton. (Original work published 1973)
- Laplanche, Jean. (1980). *Problématiques II: Castration, symbolisations*. Paris: Presses Universitaires de France.

### Further Reading

- Gifford, Sanford, rep. (1964). Panel: Repetition compulsion. *Journal of the American Psychoanalytic Association*, 12, 632–649.
- Inderbitzin, Lawrence, and Levy, Steven. (1998). Repetition compulsion revisited: Implications for technique. *Psychoanalytic Quarterly*, 67, 32–53.
- Loewald, Hans W. (1971). Some considerations on repetition and repetition compulsion. *International Journal of Psychoanalysis*, 52, 59–66.

---

## REPETITIVE DREAMS

The repetitive dream is a dream that is dreamt repeatedly and more or less identically during one's life.

Freud first thought that “a dream contains elements from childhood... where the dream is of what has been called the ‘recurrent’ type” (1900a, p. 190); subse-

quently he was of the opinion that symbolic interpretation was indispensable for an analysis of this kind of dream (1901a). He undertook a comprehensive analysis of such a repetitive dream in the case of Dora (1905e), then later, in that of the “Wolf Man” (1918b).

Taking into consideration the traumatic underpinnings of such dreams, he later changed his position, especially as it related to anxiety dreams. In “Dreams and Telepathy” (1922a) he discussed a dream, cause of much anxiety, that pursued the dreaming woman “like a ghost” (p. 209) for many years. This revision of his view of the repetitive dream occurred in the general context of metapsychological modifications resulting from his reflection on repetition itself, “beyond the pleasure principle” (1920g). Ferenczi (1931/1955) was influenced by it in writing: “Every dream, even the most disturbing ones, attempt at mastery and resolution of a traumatic experience” (p. 238).

Subsequently, the repetitive dream has been generally discussed from the perspective of the symptomatic repetition of a trauma (Rabain, 1988), as well as within the framework of metapsychological reflections on time (Seulin, 1997).

ROGER PERRON

See also: *Beyond the Pleasure Principle*; Dream; Introjection.

### Bibliography

- Ferenczi, Sándor. (1955). On the Revision of the Interpretation of Dreams. In *his Selected Papers of Sándor Ferenczi, III* (Eric Mosbacher, et al, Trans.; pp. 238–243.). New York: Basic Books. (Original work published 1931)
- Freud, Sigmund. (1900a). The interpretation of dreams. *SE*, 4–5.
- . (1920g). *Beyond the pleasure principle*. *SE*, 18: 1–64.
- Rabain, Jean-François. (1988). La mise en scène du trauma. *Revue française de psychanalyse*, 53 (6), 1373–1389.
- Seulin, Christian. (1997, April). Le temps figé des rêves récurrents. *Bulletin de la Société de psychanalyse de Paris*, 4, 91–99.

---

## REPRESENTABILITY

*Representability* is a sensory capacity of the psychic apparatus that makes it possible for an object that is

absent to be made present in the form of an image. It is active in the process of hallucination, artistic creation, and the dream work, where latent and abstract thoughts are transformed into visual images.

The notion of representability appears in chapter 6 of *The Interpretation of Dreams* (1900a) titled “The Dream Work,” in which Sigmund Freud explores the relationship between manifest content and latent thoughts, and the psychic means used in the selection and transformation of abstract thoughts into visual images. It is also found in chapter 7, “The Psychology of the Dream-Processes,” where the focus is on the dream’s instinctual force, understood as a wish-fulfillment by means of regression to sensory images.

In the mind’s use of representability, abstract thoughts are transformed into pictorial language. Among the means involved are condensation through selection of overdetermined elements, and displacement of psychic intensities along associative chains. The omission of logical and causal relationships that cannot be represented is reminiscent of the plastic arts, but the reduction to condensed terms also resembles the work of poetry, and the ambiguous syntax obtained by plays on words. The aim of this work is to make it possible for free-flowing energy to be attracted to visual images while at the same time satisfying the mind’s endopsychic censorship by means of these distortions. Primary representation-compulsion, noted in Herbert Silberer’s account of self-symbolization, should not lead us to overlook the aim of this formal regression governed by the primary process: putting an end to internal tension and “re-finding” the sensory trace of the object and the illusion of its presence. In so doing, the dream hallucinatorily fulfills a wish, and the regression is both temporal and topographical insofar as the wish is unconscious and dates from childhood.

In “A Metapsychological Supplement to the Theory of Dreams” (1916–17f [1915]), his perspective expanded by metapsychology, Freud delineated the hallucinatory process in its topographical and psychopathological dimensions. Representability involves a conscious cathexis of an instinctual demand; a negative hallucination makes it possible to deny the perception of reality.

In “Du langage pictural au langage de l’interprète” (From pictorial language to the language of the interpreter; 1980), with regard to psychosis, Piera Aulagnier returned to the idea that a consideration of representability is necessary for the analyst’s interpretation to be

dynamically effective, with regard to particular modes of thought that remain fixed to thing-presentations.

The term *representability* poses the same problems of translation as the term *representation*, which is used to render two different German terms: *Darstellung* and *Vorstellung*. Indeed the English terms do not capture the connotation, inherent in the German *Stellung-da*, of the presence of the object that is associated with all hallucinatory productions.

KATIA VARENNE

*See also:* Dream work; *Interpretation of Dreams*, *The*; Representability, considerations of; Screen memory; Visual.

### **Bibliography**

- Aulagnier, Piera. (1980). Du langage pictural au langage de l’interprète. *Topique*, 26, 29–54.
- Botella, César, and Botella, Sára. (2001). *La Figurabilité psychique*. Lausanne and Paris: Delachaux & Niestlé.
- Freud, Sigmund. (1900a). The interpretation of dreams. Part I, *SE*, 4: 1–338; Part II, *SE*, 5: 339–625.
- . (1916–17f [1915]). A metapsychological supplement to the theory of dreams. *SE*, 14: 217–35.

---

## **REPRESENTATION OF AFFECT**

The term *representation of affect* can be defined as that which constitutes the medium for the affect’s expression, in a sense serving as its vehicle in mental dynamics.

This expression, which is found in some psychoanalytic texts, is nevertheless of dubious value for metapsychology as it was expressed in Sigmund Freud’s 1915 texts brought together under that title. In those texts he clearly established that instinct, situated at the “frontier” between body and mind, is expressed in mental dynamics by means of two components: on the one hand, the ideational representative, and on the other, an energy charge, the “quota of affect” (*Affektbetrag*), whose fate can be distinct. This energy charge, when it is temporarily without a representational support, can be qualitatively transformed into various emotions (fear, pleasure, anxiety, etc.) and, under certain conditions, can cathect ideational representations awaiting the arrival of such a charge that will embody and validate them.



This is the case, for example, when anxiety “without an object” (that is, without a conscious object) becomes focused on a clearly identifiable phobogenic object; this process was clearly demonstrated in the case of “Little Hans,” related in “Analysis of a Phobia in a Five-year-old Boy” (1909), whose castration anxiety was found to be embodied in horses.

Thus, if we speak about representation of affect, it is in the sense in which a traveling salesman “represents” a product, delegated by his or her employer to perform this function for the clients (in this analogy, the instinct would be the employer, and consciousness would be the client). This usage of the term can be deemed to be congruent with one of the terms used by Freud to denote representation, *Repräsentanz*, which has precisely this meaning of “delegate,” “deputy,” or “representative” in the commercial sense.

ROGER PERRON

*See also:* Psychic representative.

### **Bibliography**

Freud, Sigmund. (1909). Analysis of a phobia in a five-year-old boy. *SE*, 10: 1–149.

———. (1915c). Instincts and their vicissitudes. *SE*, 14: 273–300.

———. (1915d). Repression. *SE*, 14: 141–158.

———. (1915e). The unconscious. *SE*, 14: 159–204.

### **Further Reading**

Caper, Robert. (2001). The place of affect in the representational world. *International Journal of Psychoanalysis*, 82, 597–600.

Slade, Arietta. (1999). Representation, symbolization, affect regulation between mother and child. *Psychoanalytical Inquiry*, 19, 797–830.

Steiner, Riccardo. (2001). Affect in psychoanalytic theory: Andre Green on affect and representation. *International Journal of Psychoanalysis*, 82, 877–900.

---

## **REPPRESSED**

The repressed is constituted by the operation of repression, which rejects and maintains in the unconscious representations deemed incompatible with the ego.

The repressed is not directly knowable, since it pertains wholly to the unconscious. It can be known only by its effects and by what it produces through deferred action, in particular “derivatives” of the unconscious.

Sigmund Freud always insisted on the unalterability of the repressed, while at the same time recognizing that it could be rearranged or even modified, especially in the course of psychoanalytic treatment. Initially, Freud considered the notion of the repressed as a correlative to that of an unconscious still distinguished by its dynamic role. In his early works Freud attributed an “intentionality” to the mind that seeks to forget and maintain outside of consciousness a certain number of unpleasurable representations (thoughts, images, memories). He posited that these representations are isolated in a “second psychical group” that is separated from the mainstream of thoughts. The psyche then becomes “dissociated,” the unpleasurable idea being relegated to another place, repressed, thus blocking any discharge of the emotion associated with it.

It can be seen that the notion of repression, as originally set forth, is correlative to that of the unconscious. For a long time—until he put forward the idea of unconscious ego defenses—Freud used the term *repressed* as a synonym for the unconscious.

However, the term *intentionality* used by Freud in 1895 must be understood in a nuanced fashion. As Jean Laplanche and Jean-Bertrand Pontalis underscored in *The Language of Psychoanalysis* (1967; trans. 1974), the “splitting of consciousness” is only “initiated” by an intentional act (p. 353). Indeed, as a “separate psychic group” repressed contents escape the subject’s control and are governed by the laws of the primary processes. The repressed representation in and of itself is an initial “nucleus of crystallization” capable of attracting other intolerable representations, without the intervention of any conscious intention.

Repression is thus conceived as a dynamic process that involves maintaining a counter-cathexis; it is always susceptible to being thwarted by an unconscious wish seeking to return to consciousness. Freud called this process “the return of the repressed.” Repressed wishes are not annihilated in the unconscious; rather, they constantly tend to reappear in consciousness through the intermediary of more or less unrecognizable derivative formations that Freud generically called “derivatives of the unconscious” or “derivatives of the repressed.” In “Repression” (1915d), Freud explained

that these derivatives can return to consciousness in the form of substitutive formations or symptoms.

The repressed is not directly knowable, since it pertains wholly to the unconscious. Just as only the products of the unconscious can be known, we can only know the derivatives of the repressed, its formations under the effects of deferred action. According to Claude Le Guen in *Le Refoulement* (1992; Repression): “The repressed is indeed a constituent part of the id, but the only thing that can make it comprehensible to us has to do with the fact that it is a product of the ego.”

Freud pointed out in “Repression” that “repression does not hinder the instinctual representative from continuing to exist in the unconscious, from organizing itself further, from putting out derivatives and establishing connections.” The instinctual representative “proliferates in the dark . . . and takes on extreme forms of expression” that “not only . . . seem alien” to the neurotic, but “frighten him” (p. 149). The repressed undergoes distortions in and by means of the derivatives that represent it, until, thus disguised, it can elude censorship and gain access to consciousness. The repressed, therefore, is anything but inert. Moreover, it “exercises a continuous pressure in the direction of the conscious, so that this pressure must be balanced by an unceasing counter-pressure. Thus the maintenance of a repression involves an uninterrupted expenditure of force, while its removal results in a saving from an economic point of view” (p. 151). Finally, the repressed that returns is never identical to what was originally repressed, because in the meantime it has been distorted—it has “worked.” Indeed, such changes are mandatory in order for the censorship to give its authorization.

For a long time Freud privileged the study of the repressed per se. His interest in the repressing agency, the ego, only took shape later. What he described in *Beyond the Pleasure Principle* as “the aim which had been set up—the aim that what was unconscious should become conscious” (1920g, p. 18) proved to be a more difficult task than he had supposed in the early days of interpreting dreams and parapraxes. Analysis ran up against repetition compulsion, and the need for punishment. The repressed could thus not explain everything, and beginning in 1923 Freud shifted his focus toward the repressing agency. In *Civilization and Its Discontents* (1930a [1929]), he wrote: “Alterations in [analytic theory] seemed essential, as our enquiries

advanced from the repressed to the repressing forces, from the object-instincts to the ego” (p. 118).

In *Beyond the Pleasure Principle*, Freud posed the problem: “We shall avoid a lack of clarity if we make our contrast not between the conscious and the unconscious but between the coherent ego and the repressed. It is certain that much of the ego itself is unconscious, and notably what we may describe as its nucleus; only a small part of it is covered by the term ‘preconscious.’ Having replaced a purely descriptive terminology by one which is systematic or dynamic, we can say that the patient’s resistance arises from his ego, and we then at once perceive that the compulsion to repeat must be ascribed to the unconscious repressed” (1920g, p.p. 19–20). It is therefore appropriate to analyze the resistances rather than bringing to light the repressed (which always represents the dynamic unconscious). In the words of Claude Le Guen (1992): “The opposition is no longer to be situated between the systems, but rather between the agencies.”

Unconscious resistance is thus a product not only of the repressed, but also of the ego, which does not want to eliminate repression. “We may say that repression is the work of this super-ego and that it is carried out either by itself or by the ego in obedience to its orders,” wrote Freud in *New Introductory Lectures on Psycho-Analysis* (1933a [1932], p. 69). The question of the fate of the repressed remains crucial, above all in relation to psychoanalytic treatment and the possibilities for change it promises. Freud always insisted on the “indestructibility” of unconscious contents. In *The Interpretation of Dreams* (1900a) he described unconscious repressed wishes as being “ever on the alert and, so to say, immortal” (p. 553). The adjective *immortal* was used again in the lecture “The Decomposition of the Psychical Personality” in *New Introductory Lectures on Psycho-Analysis*.

In the metapsychological writings of 1915, the derivatives of the repressed are said to continue to become organized, to work, and to undergo distortion in the unconscious, but these transformations in service of the defenses are not real “changes.” Freud subsequently envisioned them in terms of the treatment. Returning in the *New Introductory Lectures* to the problem of the effects of treatment on the repressed, he noted that “in certain cases the repressed instinctual impulse can subsist unaltered in the id, albeit under constant pressure from the ego. In other cases, it seems, it can

undergo a complete ‘destruction’ during which its libido is definitively directed toward other pathways.” He had already postulated the “decline” (*Untergang*) of the oedipal repressed in “The Dissolution of the Oedipus Complex” (1924d).

Returning to the question of the effects of treatment on the repressed in “Analysis Terminable and Interminable” (1937c), Freud wrote: “Psychoanalysis leads the ego, which has matured and grown stronger, to revise its formerly repressed contents; some are destroyed, while others are recognized but newly constructed out of more solid materials.” He spoke here of eliminating, destroying, and rebuilding with more solid materials. Does this not imply true change, rather than a mere distortion? “Despite the explicit repetition of statements about the unalterability of the repressed, the idea of its possible change remains implicitly present,” noted Le Guen.

Freud again took up this question of the possibility of modification of the repressed in a footnote in *Inhibitions, Symptoms and Anxiety* (1926d): “Since the differentiation of the ego and the id, our interest in the problem of repression, too, was bound to receive a fresh impetus. Up till then we had been content to confine our interest to those aspects of repression which concerned the ego—the keeping away from consciousness and from motility, and the formation of substitutes (symptoms). With regard to the repressed instinctual impulses themselves, we assumed that they remained unaltered in the unconscious for an indefinite length of time. But now our interest is turned to the vicissitudes of the repressed and we begin to suspect that it is not self-evident, perhaps not even usual, that those impulses should remain unaltered and unalterable in this way. There is no doubt that the original impulses have been inhibited and deflected from their aim through repression. But has the portion of them in the unconscious maintained itself and been proof against the influences of life that tend to alter and depreciate them? In other words, do the old wishes, about whose former existence analysis tells us, still exist? The answer seems ready to hand and certain. It is that the old, repressed wishes must still be present in the unconscious since we still find their derivatives, the symptoms, in operation. But this answer is not sufficient. It does not enable us to decide between two possibilities: either that the old wish is now operating only through its derivatives, having transferred the whole of its cathectic energy to them, or that it is itself

still in existence too. If its fate has been to exhaust itself in cathecting its derivatives, there is yet a third possibility. In the course of the neurosis it may have become re-animated by regression, anachronistic though it may now be” (p. 142n).

In “Le refoulement (les défenses)” (1986), Le Guen gave a long analysis of this footnote and the new metapsychological perspectives it can provide. Only Freud’s third hypothesis seemed to Le Guen to correspond to the experience of treatment. The old, repressed wish, having disappeared as such after expending its libidinal energy for the purpose of cathecting its derivatives, can be revived by these derivatives along a regressive pathway. This involves not a meeting up, but instead a reconstruction. By reviving the past, the present acts via deferred action (*après-coup*). By organizing the past, deferred action thus serves the function of facilitation, with the most recent derivatives facilitating the older ones.

The question envisioned here—is the repressed subject to modification?—and the proposed answer—old wishes are “re-animated by regression,” with current events reviving and transforming the past—are important, in that both theory and clinical practice are closely related to our views on the fate of the repressed. Is analysis a mere bringing to light of repressed contents (Freud’s first hypothesis of a closed, inert system), does it provoke a new, defensive arrangement of them (the second hypothesis of a closed, dynamic system), or does it have a transformative role and aims (the third hypothesis of an open, dynamic system)? These three viewpoints influence the techniques used in treatment. Indeed, they indicate actual practices as well as the implicit theories of the analyst.

JEAN-FRANÇOIS RABAIN

*See also:* Repression.

### **Bibliography**

- Freud, Sigmund. (1900a). The interpretation of dreams. *SE*, 4–5: 1–625.
- . (1915d). Repression. *SE*, 14: 141–58.
- . (1926d [1925]). Inhibitions, symptoms and anxiety. *SE*, 20: 75–172.
- Le Guen, Claude. (1992). *Le Refoulement*. Paris: Presses Universitaires de France.

Le Guen, Claude, et al. (1986). *Le refoulement (les défenses)*. *Revue française de psychanalyse*, 50, 1.

## REPRESSED, DERIVATIVE OF THE; DERIVATIVES OF THE UNCONSCIOUS

The term *repressed* was used by Sigmund Freud in the context of his dynamic conception of the unconscious. Repressed elements, which remain active in the unconscious, constantly tend to reappear to consciousness in derived formations that are unrecognizable to varying degrees: These are the “derivatives” of the unconscious that also appear in the forms of symptoms, fantasies, or free associations in the course of analysis.

It would be impossible to conceive of repression without the return of the repressed, and vice versa. The point of articulation of this process is provided by the “derivative of the unconscious” or “derivative of the repressed.” That which has been repressed in the unconscious tends to resurface in the conscious mind in the form of derivatives that, in turn, become the object of new defensive measures.

Freud used this expression, especially in the metapsychological texts of 1915, to refer to the symptoms, fantasies, and associations during the session that are connected to repressed ideas. In “The Unconscious” (1915), Freud compared these unconscious formations, these derivatives, to “individuals of mixed race”: “Thus *qualitatively* they belong to the system *Pcs.*, but *factually* to the *Ucs.* Their origin is what decides their fate. We may compare them with individuals of mixed race who, taken all round, resemble white men, but who betray their coloured descent by some striking feature or other, and on that account are excluded from society and enjoy none of the privileges of white people. . . . To this species belong the fantasmatic formations of normal men as well as neurotics, in whom we have recognized the preliminary degrees of the formation of the dream and the symptom” (p. 191).

This dual, Preconscious-Unconscious affiliation, together with their situation anterior to censorship, makes these derivatives into “necessary places of transition” through which the repressed can effect a return and through which repression can act, according to Claude Le Guen in *Le Refoulement* (Repression; 1992).

According to Freud in “The Unconscious,” the most highly organized unconscious derivatives include the

“substitutive formations” (*Ersatzbildungen*), which “succeed in breaking through into consciousness when circumstances are favorable—for example, if they happen to join forces with an anticathexis from the *Pcs.*” (p. 191). The substitutive formations (“parapraxes,” “jokes”) are nothing other than evolved derivatives that replace unconscious contents. In *Inhibitions, Symptoms and Anxiety* (1926 [1925]), Freud likened neurotic symptoms to substitutive formations put into the place of the instinctual process that has undergone the action of the defense.

The economic factor is what determines the various possible fates of the derivative. A reinforcing energy must retroactively intervene (for example, at puberty) for a mnemonic trace from childhood, reinforced by an unconscious cathexis and having become a “tolerable” derivative, to thereafter be perceived as bearable. Its relationship to action is what seals the fate of the derivative of the repressed. The derivative is condemned in its capacity as a precursor or representative of a possible putting into action.

The function of repression, which Freud in “Repression” (1915) described as “something between flight and condemnation” (p. 146), is to enlist the derivative in situations that render impossible the direct realization of unconscious desire—putting it into action.

JEAN-FRANÇOIS RABAIN

*See also:* Repression; Return of the repressed.

### Bibliography

- Freud, Sigmund. (1915d). Repression. *SE*, 14: 141–158.
- . (1915e). The unconscious. *SE*, 14: 159–204.
- . (1926d [1925]). Inhibitions, symptoms and anxiety. *SE*, 20: 75–172.
- Le Guen, Claude. (1992). *Le Refoulement*. Paris: Presses Universitaires de France.
- Le Guen, Claude, et al. (1986). *Le refoulement (les défenses)*. *Revue française de psychoanalyse*, 50, 1.

## REPRESSION

Repression is the operation by which the subject repels and keeps at a distance from consciousness

representations (thoughts, images, memories) that are disagreeable because they are incompatible with the ego. For Sigmund Freud repression is the privileged mode of defense against the instincts.

Closely linked to the discovery of the unconscious, the notion of repression accompanies all the developments of Freudian theory. It is one of its major points, “the corner-stone on which the whole structure of psychoanalysis rests” (“On the History of the Psycho-Analytic Movement” [1914d], p. 16).

Initially described in conjunction with hysteria, repression plays a major role in other mental disorders as well as in normal psychic activity. It can be considered a “universal” psychic process insofar as it is constitutive of the unconscious, itself conceived of as a separate realm of the psyche.

More generally, repression is one of the defenses (in fact the primary one) mobilized by the mind to deal with conflicts and to protect the ego from the demands of the instincts.

Four main phases relating to the development of the notion of repression can be schematically described in Freud’s writings. Until 1895, based on the idea of the “intentionality” of forgetting in the neuroses, Freud assumed the existence of “unconscious motivation.” From 1895 to 1910, his research into the repressed and its contents led to the great discoveries of this period: infantile sexuality and the Oedipus complex. Repression became the mainspring of ordinary psychic functioning. From 1911 to 1919, Freud reconsidered the process of repression in terms of the threefold metapsychological viewpoint, and he described a “primal repression.” From 1920 to 1939, with the second topography (instinctual theory), repression became one “defense mechanism” among others, but at the same time remained a “separate” process. It remained at the center of analytic discourse.

Although the word had already been used in Johann F. Herbart’s psychology, it stood out to Freud as a clinical fact. He deduced from his treatment of hysterics that forgetting is an active, intentional phenomenon, since the return of forgotten memories under hypnosis and their abreaction caused the symptoms to disappear. In *Studies on Hysteria* (1895d) Freud and Josef Breuer explained that it was “a question of things which the patient wished to forget, and therefore intentionally repressed from his conscious thought and inhibited and suppressed” (p. 10).

The term *repression*, borrowed from everyday language, thereafter followed a remarkable trajectory. Not only did it return to common speech with a different meaning, but it became one of the four main concepts of psychoanalysis.

Freud showed the existence of a veritable intentionality of the mind that seeks to forget, to cause certain disagreeable representations to disappear. These representations are isolated in a “second consciousness, a *condition seconde*” (p. 12) separated from the mainstream of thought. The psyche is thereafter “dissociated,” the unpleasant idea having been relegated to another place, “repressed,” thus blocking any discharge of painful emotion that might be associated with it. It can be seen that the notion of repression, here seized at its origins, from the outset appears as a correlate to that of the unconscious. For a long time in Freud’s work, until his positing of the idea of unconscious ego defenses, the term *repressed* was essentially synonymous with the action of the unconscious.

Moreover, the term *intentionality* used by Freud in 1895 must be understood in a nuanced way. As Jean Laplanche and Jean-Bertrand Pontalis emphasized in *The Language of Psycho-Analysis* (1967; trans. 1974), the splitting of consciousness is only “introduced” by an intentional act. As a “second consciousness,” repressed contents elude the subject’s control and are governed by the laws proper to the primary processes. The specific processes of the unconscious thus mark the operation of repression. The repressed representation in itself constitutes what Freud described in *Studies on Hysteria* as an initial “nucleus and centre of crystallization” (p. 123) that can attract other unbearable representations, without any conscious intention having to intervene. From the outset, then, repression is conceived as a dynamic process involving the maintenance of a counter-cathexis; it is always capable of being stymied by unconscious desire that seeks to return to conscious awareness, which is what is meant by “return of the repressed” (“Repression,” [1915d], p. 154).

Moreover, representations are what are repressed, but it is affect, or rather its conversion from pleasure to unpleasure, that is the *raison d’être* of repression. The vicissitude of the affect is far more important than that of the representation, for it is affect that determines the judgment bearing upon the process of repression. If the vicissitude of the representation is to disappear or be held back from consciousness, the

vicissitude of the affect, the quantitative factor of the instinctual representative, is somewhat independent.

An instinct may be suppressed, or else the affect may be affirmed under a given qualitative coloring, or, in yet another case, affect itself may be transformed into anxiety. The difference, Freud explained in “Repression,” stems from the fact that representations are cathexes, whereas affects correspond to processes of discharge whose final manifestations are perceived as sensations.

The term *repression* appeared in Freud’s writings for the first time in the “Preliminary Communication” (1893a). It was identified as a cause of pathogenic amnesia, an etiological explanatory principle leading to the envisioning of a therapeutic method that would put an opposing tendency into action. At this early date, repression was still presented as “intentional” and was not well distinguished from simple suppression. A representation appears to be painful because it is incompatible with an ego that, at this time, is still synonymous with consciousness. The ego thus treats the disagreeable idea as a “non-arrival” by repressing it.

This repression is thus posited as being a mechanism common to all mental disturbances, to hysteria, obsessional neurosis, and hallucinatory confusion. It affects only the representation; the vicissitude of the affect, for its part, determines the specificity of the disorder: conversion, isolation, or rejection (“The Neuro-Psychoses of Defence” [1894a]).

With the metapsychological writings of 1915, Freud distinguished different phases in the process of repression: fixation, “repression proper” (“Repression,” p. 148) and finally, the “return of the repressed” (p. 154), which occurs at the point of the fixation itself.

Freud described several stages in the organization of repression, for if “repression and the unconscious are correlated” (p. 148) there was a good basis for accepting the idea of a “primal repression” (*Urverdrängung*, p. 148) that represents its earliest stage. This repression does not affect the instinct, the limit concept between the psychic and the somatic, but rather its “representatives,” which thus do not gain access to consciousness. An initial unconscious nucleus is created that will function as a first pole of attraction about which elements will be repressed. This is accompanied by a “fixation,” and the so-called representative “persists unaltered” (p. 148), along with the instinct attached to it, in the unconscious.

The second stage of repression is that of “repression proper” (*eigentliche Verdrängung*) or “after-pressure” (*Nachdrängen*, p. 148), which occurs through deferred action. It involves the psychic derivatives of the repressed representative, or else a given associative chain, a predetermined train of thoughts that is related to it by association. This is a double process that joins to the attraction of the primal repressed (the earliest unconscious nucleus) a force of repulsion (*Abstossung*) that comes from consciousness and acts upon material that is to be repressed. These two forces act in tandem, with “something previously repressed ready to receive what is repelled by the conscious” (p. 148). In a note added in 1915 to the *Three Essays on the Theory of Sexuality* (1905d), Freud compared this dual process with “the manner in which tourists are conducted to the top of the Great Pyramid of Giza by being pushed from one direction and pulled from the other” (pp. 175–176, note 2). Finally, the third stage is that of the “return of the repressed” (*Wiederkehr der Verdrängten*) (p. 154), expressed in the form of symptoms, dreams, slips of the tongue, or parapraxes.

Repression does not entail the destruction or disappearance of the repressed representation. As Freud explained in “Repression,” it does not prevent the instinctual representative “from continuing to exist in the unconscious, from organizing itself further, putting out derivatives and establishing connections. . . . [T]he instinctual representative develops with less interference and more profusely if it is withdrawn by repression from conscious influence. It proliferates in the dark, as it were, and takes on extreme forms of expression, which when they are translated and presented to the neurotic are not only bound to seem alien to him, but frighten him by giving him the picture of an extraordinary strength of instinct” (p. 149).

Thus Freud in 1915 envisioned the operation of repression from a threefold metapsychological perspective. From the topographical point of view, repression is initially described, in the first theory of the instincts, as being maintained outside of consciousness. Censorship is what ensures the role of the repressing agency. In the second topography, it is posited as a defensive operation of the ego that is considered to be partially unconscious.

From the economic point of view, repression presupposes an interplay of opposing forces—of cathexis, decathexis, and anticathexis—that affect the instinctual representatives. “We may suppose that the

repressed exercises a continuous pressure in the direction of the conscious, so that this pressure must be balanced by an unceasing counter-pressure. Thus the maintenance of a repression involves an uninterrupted expenditure of force, while its removal results in a saving from an economic point of view" ("Repression," p. 151). Similarly, in "The Unconscious" (1915e), Freud specified that the preconscious protects itself from the drive of unconscious repression by means of an anti-cathexis: "It is this which represents the permanent expenditure (of energy) of a primal repression, and which also guarantees the permanence of that repression" (p. 181). The fate of the instinctual representative is to disappear from consciousness and to be kept apart from the conscious mind, but the fate of the affect, which, according to Freud, represents the quantitative factor of the instinctual representative, is different. The instinct can be suppressed, or else affect can be either expressed under a given qualitative coloration or transformed into anxiety.

Finally, from a dynamic point of view, the main question is that of the reason for repression. According to Freud, the process of repression is linked to the group of defensive processes whose goal is to reduce, or even eliminate, any modification that might endanger the integrity and constancy of the psychobiological individual. Repression is one of the great "vicissitudes" of the instinct (along with sublimation and double reversal). Freud considered it a mode of defense against the instincts.

This dynamic conception of the repressed and the unconscious is not without consequences. The unconscious tends to produce material that is connected with it to varying degrees, which Freud calls "derivatives of the unconscious" (*Abkömmlinge des Unbewussten*) ("Repression," p. 152), and which reemerge in conscious life and behaviors. These derivatives encompass, for example, symptoms, fantasies, slips of the tongue, or meaningful associations during the analytic session. They are thus also "derivatives of the repressed" (p. 149) that become, in turn, the object of new defensive measures. In his essay on repression Freud stressed that "it is not even correct to suppose that repression withholds from the conscious *all* the derivatives of what was primally repressed. If these derivatives have become sufficiently far removed from the repressed representative, whether owing to the adoption of distortions or by reason of the number of intermediate links inserted, they have free access to the

conscious. It is as though the resistance of the conscious against them is a function of their distance from what was originally repressed" (p. 149).

In analytic practice, the analyst constantly invites the patient to produce these so-called derivatives of the repressed, which, following their distancing or distortion, can pass through the censorship of consciousness. Based on the patient's associations, "we reconstitute a conscious translation of the repressed representative" (p. 150).

Freud explained that "Neurotic symptoms, too . . . are derivatives of the repressed, which has by their means finally won the access to consciousness which was previously denied to it. . . . Repression acts, therefore, in a *highly individual* manner. Each single derivative of the repressed may have its own special vicissitude" (p. 150).

Thus, repression sometimes appears as a generic term, and sometimes as a specific term. At times it is the concept on which all of psychoanalysis rests, and at other times it above all describes the mechanism of hysterical neurosis. Sometimes it is just one defense among others, and at other times it subsumes all the defenses. In psychoanalytic treatment, the stage of repression identified as "the return of the repressed" is the basis for a clinical approach aimed at the lifting of repression itself.

JEAN-FRANÇOIS RABIN

*See also:* Actual neurosis/defense neurosis; Amnesia; Censorship; Defense; Deferred action; Desexualization; Dynamic point of view, the; *Ego and the Mechanisms of Defense, The*; "Heredity and the Etiology of the Neuroses"; Hysteria; Hysterical paralysis; Id; Latency period; Organic repression; Parapraxis; Primal repression; Repressed; Repressed, derivative of the/derivative of the unconscious; "Repression"; Repression, lifting of; Resistance; Return of the repressed; Scotomization; Signal anxiety; Slips of the tongue; Suppression; Unconscious, the; Unpleasure.

### **Bibliography**

- Freud, Sigmund. (1905d). Three essays on the theory of sexuality. *SE*, 7: 123–243.
- . (1915d). Repression. *SE*, 14: 141–158.
- Freud, Sigmund, and Breuer, Josef. (1893a). On the psychological mechanism of hysterical phenomena: Preliminary communication. *SE*, 2: 1–17.

Le Guen, Claude. (1992). *Le Refoulement*. Paris: Presses Universitaires de France.

Le Guen, Claude, et al. (1986). Le refoulement (les défenses). *Revue française de psychanalyse*, 50, 1.

### Further Reading

Eagle, Morris. (2000). Repression, part I of II. *Psychoanalytic Review*, 87, 1–38.

———. (2000). Repression, part II of II. *Psychoanalytic Review*, 87, 161–188.

## “REPRESSION”

Freud’s paper “Repression” is part of a larger work that was to be called *Preliminary Essays on Metapsychology* and that was to have included twelve essays; only five of these were published. Other titles were considered, notably “Introduction to Metapsychology” and “Overview of the Transference Neuroses” (Jones, 1955, p. 185). *Metapsychology* was conceived as a group of conceptual models that did not come directly from clinical experience, but which aimed to explain clinical experience in terms of mechanisms or fictional perspectives. Freud’s project in these essays was to introduce and synthesize its main elements. In “On the History of the Psycho-Analytic Movement” (1914d) he had defined the theory of repression as “the corner-stone on which the whole structure of psychoanalysis rests . . . the most essential part of it” (p. 16).

In this paper Freud returned to the idea of repression that had previously, in *The Interpretation of Dreams* (1900a), been conflated with the idea of the defense, which he had developed beginning with the “Neuro-Psychoses of Defence” (1894a). Here repression is the only defensive modality, whereas after 1920 repression would be seen as one defense among others. Freud believed that he had found an absolutely original idea in repression, and he did not acknowledge having encountered it in the work of Schopenhauer when Rank told him of analogous perspectives in the latter’s work (Gay, 1988).

In “Repression” Freud described repression as “something between flight and condemnation” (p. 146) and said that “it is a concept which could not have been formulated before the time of psycho-analytic studies” (p. 146). His argumentation in this essay is developed step by step, by reviewing all the possibilities of this

vicissitude of the instinctual impulse. First of all, given that instinctual satisfaction is by definition pleasurable, it was necessary to posit a conflict that “would . . . cause pleasure in one place and unpleasure in another” and the condition that “the motive force of unpleasure shall have acquired more strength than the pleasure obtained from satisfaction” (p. 147).

However, this mechanistic explanation is followed by another that is dynamic in nature. Repression and the unconscious are “correlated” (p. 148), and “We have reason to assume that there is a *primal repression*, a first phase of repression, which consists in the psychological (ideational) representative of the instinct being denied entrance into the conscious. With this a *fixation* is established; the representative in question persists unaltered from then onwards and the instinct remains attached to it” (p. 148). This fixation will constitute a point of attraction for other, later repressions that are thus said to occur through “after-pressure” (p. 148).

The same dynamism affects the instinctual representative that is fixed in the unconscious, where derivatives are formed and connections established. In “Repression” Freud explained that “Repression acts . . . in a *highly individual* manner. Each single derivative of the repressed may have its own special vicissitude; a little more or a little less distortion alters the whole outcome” (p. 150). If these derivatives are sufficiently distorted, they can freely enter into consciousness. Such occurrences provide the basis for psychoanalytic treatment, in that the repressed contents can emerge through free association, enabling a conscious reconstitution of these contents through psychoanalytic interpretation. Mentioned in passing here is the issue of fetishism, which was already alluded to in *Three Essays on the Theory of Sexuality*, and to which Freud would return much later (1940a [1938]). Here he proposed, as the origin of fetishism, a division of the instinctual representative into two parts, one of which is subjected to repression while “the remainder, precisely on account of this intimate connection, undergoes idealization” (p. 150).

The distinction that Freud then proposed between representation and quota of affect enabled him to refine his ideas on the vicissitude of the instinct. One possibility is its “*transformation* into *affects*, and especially into *anxiety*, of the psychological energies of *instincts*” (p. 153). The repressed thus remains active, and returns indirectly through these substitutive formations, but



also in the form of various symptoms. The “success” of repression is often mitigated: A given representation may indeed be eliminated, but something else has been substituted for it, and “it [repression] has failed altogether in sparing unpleasure” (p. 153).

In terms of the three major categories of neurosis— anxiety hysteria, conversion hysteria, and obsessional neurosis—Freud pointed to the links that can be established between the workings of repression and the formation of neurotic symptoms. However, he added in conclusion that further research in this area needed to be done.

SOPHIE DE MIJOLLA-MELLOR

*See also:* Conversion; Free energy/bound energy; Instinctual representative; Metapsychology; Neurotic defenses; Physical pain/psychic pain; Quota of affect; Repression.

### Source Citation

Sigmund Freud. (1915d). Die Verdrängung. *Internationale Zeitschrift für ärztliche Psychoanalyse*, 3: 129–138; *GW*, 10: 248–261; Repression. *SE*, 14: 146–158.

### Bibliography

Gay, Peter. (1988). *Freud: A life for our time*. London and Melbourne: Dent.

Jones, Ernest. (1953–57). *Sigmund Freud: Life and work*. London: Hogarth.

---

## REPRESSION, LIFTING OF

*Lifting of repression* is the name for the process by which gaps in memory are eliminated, notably during psychoanalytic treatment, allowing for access to formerly unknown material.

While psychoanalysis is indeed an ensemble of theoretical conceptions that make up a metapsychology, and while it is a method of investigation of psychic processes, it is first a method of treatment (see Sigmund Freud’s article “The Libido Theory,” 1923a [1922]). From this perspective, Freud often reiterated his aim: “extracting the pure metal of the repressed thoughts from the ore of the unintentional ideas” (1904a [1903], p. 252). In “Lines of Advance in Psycho-Analytic Theory” (1919a [1918]), he wrote that “our task [is] to bring to the patient’s knowledge the

unconscious, repressed impulses existing in him” (p. 159). And in “An Outline of Psycho-Analysis” (1940a [1938]), he wrote that “the psycho-analyst is the one who is in a position to guess at repressed material.”

All of these formulations refer to what Freud usually called the “lifting of repression.” He used many different formulations to remind readers of this essential aspect of treatment. In *Introductory Lectures on Psycho-Analysis* (1916–17a [1915–17]), he wrote: “We can express the aim of our efforts in a variety of formulas: making conscious what is unconscious, lifting repressions, filling gaps in the memory—all these amount to the same thing” (p. 435).

At the time of his early discoveries, Freud observed that the sudden emergence of forgotten memories during hypnosis sessions caused symptoms to disappear. He concluded from this that forgetting was active and pathogenic, and that being cured had to be the result of the recollection and abreaction of traumatic memories. It was as if the symptom appeared in place of the memory, as if the symptom itself were a way of remembering: “The hysteric suffers from reminiscences.”

The observation of the revival of memories under hypnosis enabled Freud to theorize that a repressed representation could preserve a trace of that which had been repressed. He then shifted his focus toward resistance to remembering, the correlate of a repression that was still considered to be “intentional,” and thus onto resistance to the lifting of repression. In this way the obstacle (resistance) became a new means of unearthing meaning. The “talking cure” and the method of free association supplanted hypnosis. Memories no longer had to be rediscovered directly, but were now to be found indirectly, through the resistance that provided access to the repression.

“Suppressing gaps in memory,” that is, “eliminating resistance,” is reaffirmed in the metapsychological writings of 1915 with the expression “making the unconscious conscious.” But what in the unconscious becomes conscious? “This question remains flawed and is dependent upon a metapsychological conception in which the unconscious is largely equivalent to an immobilized past and is scarcely distinguishable from the repressed,” commented Claude Le Guen in 1992.

The central theory and the assertion “*Wo Es war, soll Ich werden*” (“Where id was, there ego shall be”) in

*New Introductory Lectures on Psycho-Analysis* (1933a [1932]) meant revisiting this issue. In 1923 Freud showed that the question was less that of bringing the repressed into consciousness and the “lifting of repression” than that of the paths to follow to be able to lead the repressed into the preconscious-conscious. The work of analysis is to put in place these preconscious intermediary terms without the unconscious having to “come up” into consciousness. Thus the unconscious, as it is activated in the id, remains indestructible and constantly active, without being affected by the unconscious impulses taken into the ego, which are capable of coming into consciousness due to the lifting of repression. It is in this way that the ego becomes the locus par excellence of conflicts between the instinctual impulses and the defensive processes, beginning with the first among them, repression. Analysis of the resistances is the essential means that must henceforth be used in treatment to bring about conscious awareness of the repressed and a lifting of repression. In the words of Le Guen, “The lifting of repression, with the liberation of libidinal energy it emanates and the unification of the ego it provokes, remains the touchstone of change in treatment and its main goal.”

JEAN-FRANÇOIS RABAIN

*See also:* Femininity; German romanticism and psychoanalysis; Infantile amnesia; Lifting of amnesia; “Negation”; Repression; Subject.

### **Bibliography**

Freud, Sigmund. (1904a [1903]). Freud’s psycho-analytic procedure. *SE*, 7: 247–254.

———. (1916–17a [1915–17]). Introductory lectures on psycho-analysis. Parts I and II. *SE*, 15–16.

———. (1919a [1918]). Lines of advance in psycho-analytic therapy. *SE*, 17: 157–168.

———. (1923a [1922]). Encyclopaedia article: “The libido theory.” *SE*, 18: 255–259.

Le Guen, Claude. (1992). *Le Refoulement*. Paris: Presses Universitaires de France.

---

## **REPUDIATION**

The term *repudiation* is the most literal translation of the terms *Verwerfung* (“foreclosure”) and *Verleugnung*

(“denial-disavowal”) that Sigmund Freud used to refer to a psychic act he wanted to distinguish clearly from repression.

In his commentary on the “Wolf Man” he declared that “A repression [*Verdrängung*] is something different from a repudiation [*Verwerfung*],” (1918 [1914]). Indeed, repression, while it erases an unpleasurable idea from consciousness, cannot prevent this idea from “working” to produce symbolic derivatives in the form of symptoms. Repudiation, by comparison, consists in invalidating a perception or mental representation, and thus is a way that allows it to remain conscious, but emptied of meaning; it is thus unable to have a role in the subject’s fantasy life.

The ultimate form of repudiation exists in what Jacques Lacan called *foreclosure*, where the representation is incapable of playing any symbolic role whatsoever (foreclosure in the Name-of-the-Father). But it can manifest itself elsewhere in a paradoxical manner by becoming inscribed within the individual topology of the split ego. In that case it will effect the kind of repudiation-disavowal seen in the so-called perverse structures. In any event, to varying degrees, such failure to symbolize an idea makes it impossible for the mental representation to be a part of the subject’s mental and fantasy life.

BERNARD PENOT

*See also:* Foreclosure.

### **Bibliography**

Freud, Sigmund. (1918b [1914]). From the history of an infantile neurosis. *SE*, 17: 1–122.

Lacan, Jacques. (1966). Du sujet enfin en question. In his *Écrits* (pp. 73–92). Paris: Seuil.

---

## **RESCUE FANTASIES**

In “A Special Type of Choice of Object Made by Men” (1910h), Sigmund Freud describes a type of man who repeatedly falls in love with a woman who is “of bad repute sexually” and “to whom another man can claim right of possession.” What is striking in such men is “the urge they show to ‘rescue’ the woman they love.”

Freud interprets the fantasy of rescue in light of the Oedipus complex: The boy initially believes his mother to be a saint and refuses to accept, when he begins to

become aware of sexual relations between adults, that his parents could behave in such a way. When the boy accepts this, the figure of the mother switches from that of the saint to that of the whore; the child is jealous of the father and regrets that the mother has not preferred him instead. “[H]e comes, as we say, under the dominance of the Oedipus complex,” and if “these impulses do not quickly pass, there is no outlet for them other than to run their course in fantasies: that of saving the beloved woman in order to win her love and obtain a baby from her, and, as a reaction to his hostility toward the father, the fantasy of saving him from a life-threatening danger by some heroic action.

Freud concludes this article by evoking imaginary scenes in which the mother is saved from drowning, a symbolic translation of the birth of a child. The following year, he added a brief reference to this theme in the 1911 edition of *The Interpretation of Dreams*. He returned to the topic at greater length in “Dreams and Telepathy” (1922a).

Although this theme is often encountered in clinical practice, it does not seem to have been further elaborated either in Freud’s work or thereafter.

ROGER PERRON

*See also:* Fantasy.

### **Bibliography**

Freud, Sigmund. (1910h). A special type of choice of object made by men. *SE*, 11: 165–175.

———. (1922a). Dreams and telepathy. *SE*, 18: 195–220.

---

## **RESISTANCE**

Psychoanalysis understands resistance as something that stands in the way of the progress of analytic work during treatment. The term appeared for the first time in Sigmund Freud’s writings in the *Studies on Hysteria* (1895d), where he reported—in connection with the case of Lucy R.—how he had given up testing the degree of hypnosis of his patients because “this roused the patients’ resistances and shook their confidence in me, which I needed for carrying out the more important psychical work” (p. 108). During his treatment of Elisabeth von R., already mindful of his own role in the clinical work, Freud perceived this resistance through the efforts he had to make in order to get his

patient to remember certain painful representations. In the Freudian psychodynamic approach, this concept refers to the psychic force that the patient opposes to the bringing into consciousness of certain unpleasurable representations during treatment: the psychic force developed to maintain repression.

If the topographical theory led to the idea that psychoanalysis was, in Freud’s words, an interpretative art that consisted of making the unconscious conscious, the analyst’s task was henceforth to “lead the patient to recognize his resistance and to reckon with it.” Analysis of the resistances thus became one of the cornerstones of analytic technique; analysis of the transference was soon linked with it.

In “The Dynamics of Transference” (1912b), Freud wondered why transference, the most effective among the factors of success, could become the most powerful agent of resistance. He was thus led to distinguish between positive and negative transference, and to conclude that “transference to the doctor is suitable for resistance to the treatment only in so far as it is a negative transference or a positive transference of repressed erotic impulses.”

Freud agreed that nothing in analysis is more difficult than overcoming the resistances. However, these phenomena are valuable because they make it possible to bring to light patients’ secret and forgotten emotions of love; above all, by endowing these with a sense of immediacy, the resistances facilitate the recognition of these emotions, because, as Freud put it in a well-known formulation, “it is impossible to destroy anyone *in absentia* or *in effigie*” (1912b, p. 108). Instead of remembering, the patient reproduces attitudes and feelings from his or her life, which, through the transference, can be used as means of resistance against the treatment and against the therapist. It is as if the patient’s intention to confound the analyst, make him feel his impotence, triumph over him, becomes more powerful than his or her intention to bring an end to his or her illness.

The article “Remembering, Repeating and Working-Through (Further Recommendations on the Technique of Psycho-Analysis II)” (1914g) marked a turning point where the discovery of repetition compulsion put an end to an illusion: Freud admitted that naming the resistance still did not make it disappear immediately. Analytic technique purported to be an art of interpretation that focused above all on recognizing the resistances and communicating them to the patient.

Discovering that “The greater the resistance, the more extensively will acting out (repetition) replace remembering” (p. 151), Freud recognized the importance of the need for working-through (*durcharbeiten*) “One must allow the patient time to become more conversant with this resistance with which he has now become acquainted, to *work through* it, to overcome it, by continuing, in defiance of it, the analytic work according to the fundamental rule of analysis” (p. 155). Freud constantly reiterated that it is the working-through of the resistances that offers the patient the greatest chance of change.

In the chapter “Resistance and Repression” in *Introductory Lectures on Psycho-Analysis* (1916–17 [1915–17]), Freud underscored the forms of the resistances, which are very diversified, extremely refined, and often difficult to recognize, and their protean character—attributes that require the physician to be cautious and to remain on guard against them. Thus, during treatment, phenomena such as gaps in memory, screen-memories, overabundant production of dreams, cessation of free association, avoidance of causal links, judgments about the insignificance of thoughts that come to mind, or even flight into treatment may all be understood as forms of resistance. But it was the most paradoxical forms of resistance—repetition compulsion and the negative therapeutic reaction—which Freud linked to unconscious feelings of guilt, that gave his study of the resistances its full amplitude.

In *Inhibitions, Symptoms and Anxiety* (1926d), Freud returned to the forms of the resistances and distinguished those of the ego, the id, and the superego. The first type is under the aegis of the pleasure principle and includes three possibilities: resistance to the lifting of repression, resistance to the loss of secondary gains from illness, and transference resistance, which aims to maintain repression. The second, resistance of the id, corresponds to “the power of the compulsion to repeat” (1926d, p. 159) and necessitates working-through. The third, resistance of the superego, comes out of the feeling of guilt and the need for punishment, which stand in the way of successful treatment; this type was later described as a negative therapeutic reaction, itself linked to the death instinct.

If Freud remained reticent on the intrinsic nature of the resistances while underscoring their variability, richness, and solidity, he always believed that the patient’s work on his or her own resistances was indis-

pensable to the success of the treatment, even positing in his last writings that this work alone carried in it the potential for real and lasting change in the ego.

Analysts after Freud have done relatively little further work on the manifestations of resistance during treatment. However, Melanie Klein, by seeing resistance essentially as a manifestation of negative transference, paved the way for a certain number of other studies, notably those of Wilfred Bion, who described psychotic resistance as “attacks on linking.”

MICHÈLE POLLAK CORNILLOT

*See also:* Acting out/acting in; Active technique; “Analysis Terminable and Interminable”; “Autobiographical Study, An”; Cathartic method; Change; Character; “Constructions in Analysis”; Cure; Defense; *Development of Psycho-Analysis*; Doubt; Ego; *Ego and the Id, The*; Evenly-suspended attention; Face-to-face situation; Fundamental rule; Id; Interpretation; Negative therapeutic reaction; *Psychoanalysis of Children, The*; Psychoanalyst; “Remembering, Repeating and Working-Through”; Repressed; Repression, lifting of; Silence; *Studies on Hysteria*; Superego; Technique with adults, psychoanalytic; Termination of treatment; Therapeutic alliance; Training analysis; Transference; “*Wild*” *Psycho-Analysis*; Working-through.

### Bibliography

- Bion, Wilfred Ruprecht. (1959). Attacks on linking. *International Journal of Psycho-Analysis*, 43 (4–5), 308.
- Freud, Sigmund. (1912b). The dynamics of transference. *SE*, 12: 97–108.
- . (1914g). Remembering, repeating and working-through (further recommendations on the technique of psycho-analysis II). *SE*, 12: 145–156.
- . (1916–17a [1915–17]). Introductory lectures on psycho-analysis. Parts I and II. *SE*, 15–16.
- . (1926d [1925]). Inhibitions, symptoms and anxiety. *SE*, 20: 75–172.
- Freud, Sigmund, and Breuer, Josef. (1895d). Studies on hysteria. *SE*, 2: 48–106.

### Further Reading

- Busch, Fred. (1995). Resistance analysis and object relations theory. *Psychoanalytic Psychology*, 12, 43–54.
- Gray, Paul. (1992). Memory as resistance, and the telling of a dream. *Journal of the American Psychoanalytic Association*, 40, 307–326.

Smith, Henry F. (1997). Resistance, enactment, and interpretation: A self-analytic study. *Psychoanalytic Inquiry*, 17, 13–30.

## RESOLUTION OF THE TRANSFERENCE

The *resolution* or *dissolution* of the transference means the end-point of a transference neurosis and the full recognition by the analysand that his or her relationship to the psychoanalyst is based primarily on the repetition of earlier relationships, namely those of childhood.

Freud's first explicit mention of the resolution of the transference was in "Recommendations to Physicians Practising Psycho-Analysis," where he described it as "one of the main tasks of the treatment" (1912e, p. 118). The introduction of this idea, implying as it did an overall view of the transference, was part of Freud's conceptualization of the transference neurosis, and of the analytic treatment as a process: "on the whole, once begun, it goes its own way and does not allow either the direction it takes or the order in which it picks up its points to be prescribed for it. . . . A man can, it is true, beget a whole child, but even the strongest man cannot create in the female organism a head alone, or an arm or a leg. . . . He, too, only sets in motion a highly complicated process, determined by events in the remote past, which ends in the severance of the child from its mother. A neurosis as well has the character of an organism" (1913c, p. 130).

The "resolution of the transference" is one of the most important issues of all for psychoanalytic technique. The transference is at once the motor of the treatment and a means for combating resistances, but it may also itself be the source of resistances to the progress of the analytic work. It can be seen as the manifest content where the latent content is the infantile neurosis. Transference is not just a kind of "acted-out" repetition whose elucidation opens the way to the patient's remembering; it is at the same time a new experience—"a piece of real experience, but one which has been made possible by especially favorable conditions, and it is of a provisional nature" (1914g, p. 154). The resolution of the transference (or its "overcoming" by the analysand) necessarily subsumes all this, as well as the patient's eventual detachment from the analyst once this "piece of experience," with its "provisional nature," has come to an end.

Freud was always much concerned with the proper handling of transference phenomena, with restricting the power of suggestion to what would advance the analytic work, and with the danger of embarking on some kind of mutual analysis or love relationship, even in the most limited sense. As he wrote in "The Dynamics of Transference," "We take care of the patient's final independence by employing suggestion in order to get him to accomplish a piece of psychical work which has as its necessary result a permanent improvement in his psychical situation" (1912b, p. 106). Freud's view was that the intensity of the transference neurosis must be limited, so that the patient could "recognize that what appears to be reality is in fact only a reflection of a forgotten past" (1920g, p. 19).

Freud viewed the resolution of the transference as an imperative in psychoanalysis, which was properly so called solely "if the intensity of the transference has been utilized for the overcoming of resistances. Only then has being ill become impossible, even when the transference has once more been dissolved, which is its destined end" (1913c, p. 143). That this resolution had to occur by degrees, along with the progress of the treatment, was something that Freud indicated implicitly—as for example when he recommended that "the transferences" (considered here by analogy with symptoms) be destroyed one by one, as the work proceeded, or when he observed that negative aspects of the transference "in good time" (1905 [1901], p. 118). The "dissolution" of the transference, which coincided necessarily with the end of the treatment—"At the end of an analytic treatment the transference must itself be cleared away" (1916–17a [1915–17], p. 453)—was possible only if its progress towards resolution had paralleled the evolution of the analysis itself.

Thus the resolution of the transference was not just an ethical necessity for Freud, it was also an intrinsic aspect of the treatment; the patient's presenting neurosis was transformed into a transference neurosis, a kind of relay condition whose cure by means of the resolution of the transference secured a general therapeutic outcome: "All the patient's symptoms have abandoned their original meaning and have taken on a new sense which lies in a relation to the transference. . . . But the mastering of this new, artificial neurosis coincides with getting rid of the illness which was originally brought to the treatment—with the accomplishment of our therapeutic task. A person who has become normal and free from the operation of repressed instinctual impulses in

his relation to the doctor will remain so in his own life after the doctor has once more withdrawn from it” 1916–17a [1915–17], pp. 444–445).

James Strachey (1934) introduced transference interpretation, a method of relating current transference experience to the past as a way of helping resolve the transference; he saw this method as a model of “mutational” interpretation and as a specifically psychoanalytical therapeutic approach.

PAUL DENIS

*See also:* Counter-transference; Negative therapeutic reaction; Transference.

### **Bibliography**

Freud, Sigmund. (1905e [1901]). Fragment of an analysis of a case of hysteria. *SE*, 7: 1–122.

———. (1912b). The dynamics of transference. *SE*, 12: 97–108.

———. (1912e). Recommendations to physicians practising psycho-analysis. *SE*, 12: 109–120.

———. (1913c). On beginning the treatment (further recommendations on the technique of psycho-analysis I). *SE*, 12: 121–144.

———. (1914g). Remembering, repeating and working-through (further recommendations on the technique of psycho-analysis II). *SE*, 12: 145–156.

———. (1916–17a [1915–17]). Introductory lectures on psycho-analysis. *SE*, 15–16.

———. (1920g). Beyond the pleasure principle. *SE*, 18: 1–64.

Strachey, James. (1934). The nature of the therapeutic action of psycho-analysis. *International Journal of Psycho-Analysis* 15, 127–159. Reprinted in *International Journal of Psycho-Analysis* 50 (1969), 275–291.

### **Further Reading**

Modell, Arnold H. (1988). Treatment, psychic structure: Resolution of the transference. *Journal of the American Psychoanalytic Association*, 36 (S), 225–240.

---

## **RETURN OF THE REPRESSED**

The return of the repressed is the process whereby repressed elements, preserved in the unconscious, tend

to reappear, in consciousness or in behavior, in the shape of secondary and more or less unrecognizable “derivatives of the unconscious.” Parapraxes, bungled or symptomatic actions, are examples of such derivatives.

Beginning with *The Interpretation of Dreams* (1900a), Freud always emphasized the “indestructible” nature of unconscious material, as likewise the irreducible character of memory traces. If we have no memories of events during the first years of life, this is because of the repression that affects them. In a sense, all memories may be said to be retained, their recollection depending solely on the way in which they are cathected, decathected, or anticathected.

In the thirty-first of his *New Introductory Lectures*, “The Dissection of the Psychical Personality,” Freud posited the unalterability of the repressed in the following terms: “impressions, . . . which have been sunk into the id by repression, are virtually immortal; after the passage of decades they behave as though they had just occurred” (1933a [1932], p. 74). In *Moses and Monotheism*, he added: “What is forgotten is not extinguished but only ‘repressed’; its memory-traces are present in all their freshness, but isolated by ‘anticathexes’ . . . they are unconscious—inaccessible to consciousness” (1939a [1934–38], p. 94).

Thus for Freud repressed wishes are not destroyed in the unconscious: rather, they are forever re-emerging in the form of what are generically called derivatives of the unconscious, some of which “become conscious as substitutive formations and symptoms—generally, it is true, after having undergone great distortion as compared with the unconscious, though often retaining many characteristics which call for repression” (1915e, p. 193). Such derivatives include not only symptoms but also fantasies, slips of the tongue, and parapraxes in general, and even certain character traits. They are expressions of the unconscious manifesting themselves in consciousness without this necessarily implying that what has been repressed becomes conscious: The repressed returns, but often remains unrecognizable. Such returns of the repressed are par excellence the material that the psychoanalyst works on, and they may refer as easily to the transference as to associations produced in the analytic session that are connected to the repressed ideas.

Freud links “symptom formation” (*Symptombildung*) to the return of the repressed: “it is not the repression itself which produces substitutive

formations and symptoms, but that these latter are indications of a *return of the repressed*” (1915d, p. 154). Broadly speaking, symptom formation encompasses not just the return of the repressed by means of “substitutive formations” or “compromise formations” but also “reaction formations” created as bulwarks against repressed wishes.

The return of the repressed was considered by Freud to be a “specific” mechanism (Freud to Ferenczi, December 6, 1910), a view he reiterated in his paper on “Repression,” where it is portrayed as a third distinct phase in the overall process of repression, following “primal repression” and “repression proper” or “after-pressure” (1915d, p. 148).

In a section of *Moses and Monotheism* dealing with the return of the repressed, Freud evokes the re-emergence of the “impressions” of early childhood and the instinctual demands that can erupt into the life of the subject, orientating his actions and subjecting him to constraining impulses. The instinct “renews its demand, and, since the path to normal satisfaction remains closed to it by what we may call the scar of repression, somewhere, at a weak spot, it opens another path for itself to what is known as a substitutive satisfaction, which comes to light as a symptom, without the acquiescence of the ego. . . . All the phenomena of the formation of symptoms may justly be described as the ‘return of the repressed.’ Their distinguishing characteristic, however, is the far-reaching distortion to which the returning material has been subjected as compared with the original” (1939a, p. 127).

The repressed thus retains its initial impulse, its urge to penetrate consciousness. It may achieve this, according to Freud, under three conditions: “(1) if the strength of the anticathexis is diminished by pathological processes which overtake the other part [of the mind], what we call the ego, or by a different distribution of the cathectic energies in that ego, as happens regularly in the state of sleep; (2) if the instinctual elements attaching to the repressed receive a special reinforcement (of which the best example is the processes during puberty); and (3) if at any time in recent experience impressions or experiences occur which resemble the repressed so closely that they are able to awaken it. In the last case the recent experience is reinforced by the latent energy of the repressed, and the repressed comes into operation behind the recent experience and with its help.” Freud adds that “In

none of these three alternatives does what has hitherto been repressed enter consciousness smoothly and unaltered; it must always put up with distortions which testify to the influence of the resistance (not entirely overcome) arising from the anticathexis, or to the modifying influence of the recent experience or to both” (1939a, p. 95).

JEAN-FRANÇOIS RABAIN

*See also:* Acting out/acting in; Character; Double, the; Dream; Estrangement; Fixation; Formations of the unconscious; Neurotic defenses; Historical truth; Idea/representation; Ideational representative; *Interpretation of Dreams, The*; Judgment of condemnation; *Moses and Monotheism*; Persecution; Projection; Remembering; Repression; Substitute/substitutive formation; Substitutive formation; Symbolic equation; Topology; Totem/totemism; “‘Uncanny,’ The.”

### Bibliography

- Freud, Sigmund. (1900a). The interpretation of dreams. *SE*, 4–5.
- . (1915d). Repression. *SE*, 14: 141–158.
- . (1915e). The unconscious. *SE*, 14: 159–204.
- . (1933a [1932]). New introductory lectures on psycho-analysis. *SE*, 22: 1–182.
- . (1939a [1934–38]). *Moses and monotheism: Three essays*. *SE*, 23: 1–137.
- Freud, Sigmund, and Ferenczi, Sándor. (1993–2000). *The correspondence of Sigmund Freud and Sándor Ferenczi* (Volume 1: 1908–14; Eva Brabant, Ernst Falzeder, and Patrizia Giamperri-Deutsch, Eds.; Peter T. Hoffer, Trans.). Cambridge, MA: Belknap Press of Harvard University Press.
- Le Guen, Claude. (1992). *Le Refoulement*. Paris: Presses Universitaires de France.
- Le Guen, Claude, et al. (1986). Le refoulement (les défenses). *Revue française de psychanalyse*, 50, 1.

### REVERCHON-JOUVE, BLANCHE (1879–1974)

Blanche Reverchon-Jouve was a French physician and psychoanalyst, a member of the Société psychanalytique de Paris and the Société française de psychanalyse, and a translator of Freud. She was born in 1879 and died January 8, 1974.

She studied in France, and later specialized in neurology under Babinski. She practiced psychiatry in Geneva and was one of the women celebrated in *La Garçonne* (Margeuritte, 1922). In 1921 she met the poet Pierre Jean Jouve. She and Jouve were invited by Stefan Zweig to participate in two of the conferences he gave in Salzburg. In 1923, after traveling to Bavaria, they began living together in Paris. They were married in 1925, following Jouve's divorce.

Reverchon-Jouve was analyzed by Eugénie Sokolnicka and became a member of the Société psychanalytique de Paris. She appears on the 1932 list as an associate member, then on a second, corrected list as a full member.

In 1923 Gallimard published *Trois essais sur la théorie de la sexualité* by Sigmund Freud, a translation she completed with the help of Bernard Groethuysen. With Jouve she wrote an article for the *Nouvelle Revue Française* of 1933 entitled "Moments d'une psychanalyse." Although a clinical study, it did not resemble those published by her peers. It was the work of an analyst and writer, and its formal beauty as literature casts doubt on the authenticity of the narrative.

On February 3, 1931, in Paris, she was presented as a member the French section of the Soroptimists, the international women's association. She did not train any students and her patients, often wealthy, provided her and her husband with a good income. They created a small circle around themselves, primarily centered on her husband. Olivier, Jouve's son by his first wife, married a woman in their circle, a dancer, in spite of his stepmother's advice to the contrary.

Reverchon-Jouve participated in the 1950 World Psychiatric Congress organized by Henri Ey and, at the time of the 1953 split, she joined Daniel Lagache when he founded the Société française de psychanalyse.

JEAN-PIERRE BOURGERON

*See also:* France; Jouve, Pierre Jean; Société française de Psychanalyse.

### **Bibliography**

Reverchon-Jouve, Blanche, and Jouve, Pierre Jean. (1933). Moments d'une psychanalyse. *Nouvelle Revue Française*, 234, 353–385.

Roudinesco, Élisabeth. (1990). *Jacques Lacan & Co.: A history of psychoanalysis in France, 1925–1985* (Jeffrey

Mehlman, Trans.). Chicago: University of Chicago Press. (Original work published 1986)

---

## **REVERIE**

The term *reverie* refers to an imaginary representation created to help realize a desire. The term *Phantasie* was used by Freud to designate such mental activity collectively, whether conscious or unconscious. In French the term *fantasme* prevailed in psychoanalytic use, for it was felt that the term *fantaisie* was too marked by current usage, where it connotes the idea of capriciousness or gratuitousness. However, following Daniel Lagache (1964), the term *fantaisie* came to refer to imaginary conscious or preconscious creations, without ignoring their continuity with the unconscious fantasies they reflect.

Daydreams, which everyone experiences, are the clearest examples of conscious or preconscious reveries. In general they explicitly satisfy a desire, providing some form of imaginary satisfaction, whether it be erotic, aggressive, ambitious, self-aggrandizing, or uplifting. It is not even unusual for people to visualize painful or humiliating experiences to their own advantage. In all these cases the narcissistic dimension of the process is obvious.

There are references to such daydreams in the *Studies on Hysteria* (1895d), primarily in the case study of Anna O., written by Josef Breuer. Freud wrote about daydreams in *The Interpretation of Dreams* (1900a). For example, when analyzing his dream about the "botanical monograph," he relates a daydream during which he imagines that, afflicted by glaucoma, he travels incognito to Berlin for an operation and experiences considerable pleasure in listening to the surgeon extol the anesthetic qualities of cocaine (thus being compensated for the pain Freud experienced through being too late to be recognized as the one who discovered its properties). The "phantasies or day-dreams are the immediate forerunners of hysterical symptoms. . . . Like dreams they are wish-fulfillments; like dreams, they are based to a great extent on impressions of infantile experiences; like dreams, they benefit by a certain degree of relaxation of censorship" (p. 491–492)

According to Freud, a daydream is initially the expression of an unconscious fantasy; then, it is used as available material among the latent thoughts used by dreams. However, as he noted, there is an essential



difference between night dreams and daydreams: the first is hallucinatory, the second is not, and the person remains more or less clearly aware that his daydream is an escape from a reality that is not completely suspended.

This distinction can be blurred or even disappear entirely. Freud analyzes this phenomenon in his detailed commentary on Wilhelm Jensen's *Gradiva* (1907a). In the same period, in "Creative Writers and Daydreaming" (1908e [1907]), he discusses the function of daydreaming in the genesis of the literary work, and later, in "Family Romances" (1909c [1908]), he foresees the situation where daydreams are used by the child to avoid the oedipal conflict by imagining himself to be adopted, to be really the child of a king and queen.

Robert Desoille (1961) developed an original method of psychotherapy based on the development and analysis of the patient's daydreams during therapy. For some patients and under certain circumstances, analytic psychodrama can create scenarios that are related to daydreams.

ROGER PERRON

*See also:* Amentia; Boredom; Censoring the lover in her; Compromise formation; "Creative Writers and Daydreaming"; Creativity; Directed daydream (Robert Desoille); Ego ideal; Family romance; Psychoanalysis of fire, the; Unconscious fantasy.

### **Bibliography**

Anargyros-Klinger, Annie, Reiss-Schimmel, Ilana, and Wainrib, Steve. (1998). *Création, psychanalyse*. Paris: Presses Universitaires de France.

Desoille, Robert. (1961). *Théorie et Pratique du Rêve-éveillé-dirigé*. Geneva: Le Mont-Blanc.

Lagache, Daniel. (1964). Fantaisie, réalité, vérité. *Revue française de psychanalyse*, 28 (4), 515–538.

## **REVERSAL INTO THE OPPOSITE**

The expression *reversal into the opposite* refers to the transformation of an idea, a representation, a logical figure, a dream image, a symptom, an affect, or the like into its opposite. It is a process that affects the fate of the instincts, notably in the transformation of love into hate, and was more clearly described in Freud's discussion of the notion of turning around.

Freud first described this type of transformation with regard to dream images. Such reversals are used to create the disguises that enable the translation of latent thoughts into acceptable thoughts (which are thus able to cross the barrier of censorship). He gave numerous examples of this in *The Interpretation of Dreams* (1900). This process can affect characteristics of objects or people; thus, a small object can appear to be very large in a dream; someone whose intelligence is envied appears stupid in the dream, and so forth. Often a reversal of actions into their opposite is involved: Climbing a staircase expresses the idea of descending or falling; the latent idea of a heavy burden is translated in the dream by the action of carrying a light woman, and so on.

In the dream "Non vixit," the dreamer (Freud himself) with the intensity of his gaze melts a person whose blue eyes are growing paler: This expressed a reversal into its opposite of the fear that he had experienced, when he was young, under the gaze of Brücke's "terrible blue eyes" (1900a, p. 422). He gave a detailed analysis of a particularly interesting instance of reversal into the opposite in the case of the "Wolf Man"'s dream (related in "From the History of an Infantile Neurosis" [1918b]), in which the scary immobility of the wolves was a reversal of a violent movement (that of his parents' coitus). Reversals of the dream protagonists' roles may occur, such as the hare chasing the hunter, or the dreamer punishing his father.

Certain logical relationships can also be expressed in this way. Contradiction, for example, may lead in a dream to a condensation in which opposites are blended together in a depiction marked by a sense of absurdity. Temporal reversal of dream episodes is particularly interesting: "The outcome of the incident or the conclusion of a line of reasoning is the introduction to the dream, and the premises of the reasoning or the cause of the incident is found at the end."

But reversal into the opposite does not only affect representations or relationships between representations, it can also apply to affects: "There is yet another way in which the dream-work can deal with affects in the dream-thoughts... It can *turn them into their opposite*" (1900a, p. 471). Thus, a depressive feeling of self-devaluation can inspire a dream of brilliant success, or, on the contrary, a feeling of triumph may provoke a dream that recalls a humiliating failure. In the dream of the "uncle with the yellow beard," Freud's "warm dream feeling of affection [for his friend R.] in

the dream” masked the wish that R. be a “simpleton” (p. 140–141).” R. was a possible rival for nomination to the title of professor. The analysis of such transformations is a valuable tool for understanding the dream-work.

According to Freud in *The Interpretation of Dreams*: “[R]eversal [*Umkehrung*], or turning a thing into its opposite [*Verwandlung ins Gegenteil*], is one of the means of representation most favoured by the dream-work and one which is capable of employment in the most diverse directions. . . . [R]eversal is of quite special use as a help to censorship” (p. 327). From this it can be deduced that in this function as a process or a subterfuge to circumvent censorship, reversal clearly comes into play beyond the realm of the dream-work. This is the case in many myths: for example, those in which birth (emergence from water) is represented either by rising from the waves (as in the birth of Venus) or, on the contrary, by an episode in which the hero enters the water (as in the story of Moses).

This play of opposites is found in certain linguistic expressions that, according to context, can take on opposite meanings: Thus, the Latin word *sacer* means both “holy” and “damned”; the German *Boden* refers both to that which is highest and that which is lowest in a house, and so forth. According to Freud in “The Antithetical Meaning of Primal Words” (1910e), where he invoked the (now-contested) authority of the linguist Karl Abel, this phenomenon was frequent in “primitive languages” that were supposedly still poorly differentiated and thus often used condensations. In the eleventh lecture in the *Introductory Lectures on Psycho-Analysis* (1916–1917a [1915–1917]), Freud explicitly compared this play of opposites in language with its function in the dream-work. But this is not limited to the semantic level: Figures of speech can be subjected to such a mechanism, the most obvious case being that of negation, discussed in “Negation” (1925h), in which a thought is expressed in inverse form, accompanied by a projection that makes it possible to attribute it to someone else (“‘You ask who this person in the dream can be. It’s *not* my mother.’ We emend this to: ‘So it *is* his mother’” [1925h, 235].)

Symptom formation often makes use of this mechanism. The hysteric who is simulating rape tears her dress with one hand and clutches it around her body with the other; the fantasy in which she holds her sexual partner against herself is translated into her hands clasped behind her back, and coitus itself is expressed via hyperextension in a circular arc (“Some

General Remarks on Hysterical Attacks” (1909a [1908]), and so on. In such cases, what the hysteric acts out is an idea or image of an action—that is, a fantasy that corresponds to one of the received meanings of the idea. The same reversal of action is seen in dreams that center on a given idea or image.

Reversal into the opposite, especially in the case of a reversal of affect, involves a process very similar to those referred to as *turning [a]round*. The terminology is not very clear: Freud himself, moreover, in “Instincts and Their Vicissitudes” (1915c), used the term *reversal* to designate both processes, the turning around of activity into passivity and the reversal into opposite of the “contents” of the love/hate pair. However, it seems judicious to distinguish the two notions and to use the notion of turning around with reference (a) to expressions of drives as affects (love into hate, or the reverse); (b) to aims of drives (the active aim “turning around” into a passive aim); and (c) to the objects of drives. This also applies to the whole notion of the sadism/masochism pair. The notion of reversal into the opposite should be used, as is evident from the preceding, when formal aspects of transformations affecting representational contents are involved.

Both notions, however, can be subsumed into the broader category of “pairs of opposites” frequently found in Freud’s work, culminating in his second theory of the instincts with the oppositional pair Eros/the death instinct.

ROGER PERRON

*See also:* Activity/passivity; Death instinct (Thanatos); *Ego and the Mechanisms of Defence, The*; Identification with the aggressor; “Instincts and Their Vicissitudes”; Manifest; Organic repression; Partial drive; Sadomasochism; “Theme of the Three Caskets, The”; Turning around; Turning around upon the subject’s own self; Voyeurism.

### **Bibliography**

- Freud, Sigmund. (1900a). The interpretation of dreams. *SE*, 4–5: 1–625.
- . (1909a [1908]). Some general remarks on hysterical attacks. *SE*, 9: 227–234.
- . (1916–1917a [1915–1917]). Introductory lectures on psycho-analysis. *SE*, 15–16.
- . (1918b [1914]). From the history of an infantile neurosis. *SE*, 17: 1–122.
- . (1925h). Negation. *SE*, 19: 233–239.

## REVISTA DE PSICOANÁLISIS

The Argentine Psychoanalytic Association was founded in 1942. The *Revista de Psicoanálisis*, its official organ, appeared only seven months later, in 1943. Its first editor was Arnaldo Rascovsky, one of the pioneers of the Argentine psychoanalytic movement.

The *Revista* has appeared continuously ever since, without interruption; it is thus the oldest psychoanalytic journal in the Spanish language, as well as one of the oldest psychoanalytic journals in the world. From its beginning until 1976, the *Revista de Psicoanálisis* appeared four times a year; since 1977 it has appeared six times yearly. These circumstances, plus its edition (print run) of 2,000 issues, its scientific quality, its prestige, and the important role it has played in the diffusion of psychoanalysis in Latin America, have caused the International Psychoanalytical Association (IPA) to choose the *Revista* to publish its *Bulletin* in Spanish whenever it was required, to publish the “pre-published” Congress papers, and to have the first right to choose the Congress papers it wishes to publish. In return, the Argentine Psychoanalytic Association sends an adequate number of the issues, containing the *Bulletin* and the pre-published Congress papers, to each of the IPA’s Spanish-speaking component societies.

At first, the *Revista* contained more translated papers than local productions. Long ago this situation was reversed, however, and the scientific production of Argentine analysts has come account for the vast majority of papers in a given issue.

Many of Freud’s papers appeared in Spanish for the first time in the *Revista*; for instance, “Analysis Terminable and Interminable,” in 1946. The Freudian tradition has remained continuous through the years. All “classic” authors and their continuators have had a place in the *Revista*. Also all contemporary schools or frames of reference have found their place there, either in their original authors’ publications, or through the papers of local followers.

Argentina is equally far from both Europe and the United States. This circumstance has many disadvantages but some advantages, that is: psychoanalysts from Argentina have been able to maintain a relative independence of thought, have been exposed to all frames of references, and have been able to avoid compromises, political or otherwise, with a given system of thought. This pluralism is reflected in the *Revista de*

*Psicoanálisis*; the titles and authors who have appeared in it offer a balanced view of current psychoanalytic thinking. Also, in the bibliography of the papers of Argentinian analysts, it is usual to find references to European, North American, and Latin American authors. Some decades ago the Kleinian School was preponderant, as European authors have become somewhat preponderant.

Following an international trend, the *Revista* has begun to publish issues with a given theme. In addition, a “Special International Issue,” also with a given theme, has appeared, but with the collaboration of invited and interested prominent analysts from many countries.

In spite of its respectable age, the *Revista de Psicoanálisis* remains an extremely active, contemporary, and purposely pluralistic publication.

CARLOS MARIO ASLAN

See also: Argentina; Cárcamo, Celes Ernesto; Rascovsky, Arnaldo.

## REVISTA DE PSIQUIATRIA Y DISCIPLINAS CONEXAS

Hermilio Valdizán and Honorio Delgado founded the review *Revista de psiquiatria y disciplinas conexas* in Lima in 1918. The subtitle highlights its interdisciplinary vocation: “A quarterly publication on psychiatry, psychoanalysis, pedagogy, sociology, forensic medicine, criminology and the history of medicine.” By 1924 five volumes had appeared in quarterly issues. The review achieved the objective it had set for itself: it was the first modern review of psychiatry in Peru.

The psychoanalytic content of the publication is remarkable in comparison to the dates of appearance of the dedicated psychoanalytic reviews of the time: *Imago* (1912), *Internationale Zeitschrift für Psychoanalyse* (1913), and *The Psychoanalytic Review* (1913) are the only ones to precede it. *The International Journal of Psycho-Analysis* and the *Revue Française de Psychanalyse* did not appear until 1920 and 1927 respectively. In a country as isolated from the international psychoanalytic community as Peru, and exposed to the difficulties of communication and the prejudices of a Catholic society, such an event is all the more remarkable.

With the appearance of the third issue (January, 1920) the review became militant, with an editorial signed by Delgado, "Freud and the psychoanalytic movement," illustrated with a full-page portrait of the founding father. Sigmund Freud mentioned the publication on two occasions: in a footnote added in 1923 to "On the History of the Psychoanalytic Movement," (1914d) and in a note added in 1924 to *The Psychopathology of Everyday Life* (1901b).

These facts confirm that Freud read the review attentively. In a letter dated 1924 he complained about its disappearance and asked Delgado if he intended to introduce another publication. In a report on Spanish-language psychoanalytic literature, Karl Abraham quotes from and comments on different works by Delgado and authors writing in the review. In 1922 an agreement was reached to publish a Spanish version of *Die Don Juan Gestalt*, but the project was hindered by the length of the work. The content of the review with regard to psychoanalytic books and publications proved to be top quality; it published timely comments on recent works by Freud, Abraham, and Sándor Ferenczi, and reports on the journals *Imago*, *Internationale Zeitschrift für Psychoanalyse*, and *The International Journal of Psycho-Analysis*.

Honorio Delgado figures with Paul Wilson and Hermilio Valdizán among those who published most on psychoanalysis in Peru at the time. Wilson, who always published in English, is most noteworthy for "The Imperceptible Obvious," on which Freud commented in detail in the above-mentioned note in *Psychopathology*. The article that appeared under the pseudonym "A. Z." in volume 2, number 1 (July, 1919): "Psychoanalytic treatment of a case of compulsive neurosis," constitutes the first Spanish-language account of psychoanalytic treatment.

It is difficult to determine the impact of the review. Its authors lacked analytic experience and made excessive claims to therapeutic success. Their theories were eclectic: a blend of ideas from Freud, Adler, and Jung. In spite of this, the review played a pioneering role in Latin America and in the Spanish-speaking community, contributing in a remarkable fashion to the spread of knowledge about psychoanalysis.

ÁLVARO REY DE CASTRO

See also: "A. Z."; Delgado, Honorio; Peru; Valdizán, Hermilio.

### Bibliography

- Abraham, Karl. (1921). Literatur in spanischer Sprache. In *Bericht über die Fortschritte der Psychoanalyse in den Jahren 1914–1919* (pp. 366–367). Leipzig, Wien and Zürich: Internationaler psychoanalytischer Verlag.
- Freud, Sigmund. (1901b). The psychopathology of everyday life. *SE*, 6.
- . (1914d). On the history of the psycho-analytic movement. *SE*, 14: 1–66.
- Mariátegui, Javier, and León, Ramón. (1987). *La Revista de psiquiatría y disciplinas conexas (1918–1924)* (pp. 1–41). Lima: Instituto de Salud Mental y Universidad Peruana Cayetano Heredia.
- Rey de Castro, Álvaro. (1993). Lettres de Sigmund Freud à Honorio Delgado, 1919–1934. *Revue internationale d'histoire de la psychanalyse*, 6.

---

### REVUE FRANÇAISE DE PSYCHANALYSE

At the founding of the Société psychanalytique de Paris (SPP; Paris Psychoanalytical Society) on November 4, 1926, "it was decided to create a French journal of psychoanalysis, the medical part of which would be edited by MM. Laforgue and Hesnard, possibly joined by MM. de Saussure and Odier after their acceptance into the society, and the nonmedical part of which would be edited by the Princess Marie Bonaparte. M. Éd. Pichon accepted in principle the responsibilities of general secretary of this publication."

From the very inception of this publication, which could not have come into being without the financing of Marie Bonaparte, René Laforgue, and Prynns Hopkins, a very wealthy former patient of Ernest Jones, disputes arose around the issue of whom it belonged to. Even its title was contentious in this regard, for while Laforgue presented it to Sigmund Freud on November 27 as the "*Revue internationale de psychoanalyse*," the spelling *psychanalyse*, associated with the habits of the Swiss and the Jungians, was finally chosen. There was another, more serious problem that had to do with ambivalence on the part of the young psychiatrists who had created the journal *Évolution psychiatrique* (Developments in psychiatry) the previous year and who dreamed of a "French-style" psychoanalysis: the exclusion of the phrase "under the patronage of Professor Freud" from the title page, on the pretext that its presence might "gravely offend"

Henri Claude. Writing to Laforgue from Vienna on November 12, Marie Bonaparte expressed her indignation over this: “But I feel we are cowards, triple cowards, if we do not dare to put the name of the founder of the science we represent on the first journal in France devoted to his work.” She added: “Freud made a comment to me that I must pass on to you. It was that we should not name our journal the ‘Revue internationale de psychanalyse,’ because it is not international at all. If the British journal uses that name, it is because it is only a reproduction of the German journal. . . . Freud believes that we should go back to one of our first titles: ‘Revue française de psychanalyse,’ with, below it, ‘organ of the Paris Psychoanalytical Society,’ French section of the International Psychoanalytical Association (and I say) published under the patronage of Sigm. Freud. And nothing else on the title page. All our names on the back of the page, written in the smallest possible characters! If Claude takes offense, he is really too stupid.”

Finally, the French opted for “Revue française de la psychanalyse, organ of the S.P.P., published under the patronage of Professor Freud” in the first issue, which appeared on June 25, 1927. “We believe that today French psychoanalysis is ripe to have its own organ of expression. It will be the mirror of the young Paris Psychoanalytical Society, born this winter,” said the editorial. Alongside original pieces by Laforgue, Charles Odier, René Allendy, Angélo Hesnard, Félix Deutsch, and the First Conference of French-Speaking Psychoanalysts, and the administrative minutes of the nascent SPP, the issue included Freud’s “Moses and Michelangelo” and Bonaparte’s “The Case of Madame Lefebvre.” By way of a contribution, Freud did not ask for any royalties for his text, which was translated by the princess, and even provided an unpublished addendum. The phrase “section of the International Psychoanalytical Association” did not appear until the second issue.

It was the nationalistic contingent, enamored of a “Latin” mindset tinged with anti-Semitism and led by Édouard Pichon, that was behind these acts of pettiness—to the great anger of Bonaparte, who would not rest until she saw him removed from the editorship of the journal; at one point she wanted to withdraw it from the publisher Doin in favor of Gaston Gallimard. In late October 1929, opposition to the International Psychoanalytical Association by a “very active minority” that wanted to take control of the journal, since it

was referred to as the “Official Organ of the French Group,” again raised the idea of “transforming the French Journal into an International Journal of Psych.” (letter from Laforgue to Freud, October 26, 1929). The princess was opposed to this and succeeded in having Rudolph Loewenstein appointed editor in place of Pichon. By contrast, Ernest Jones deplored the label “French Journal” because it allowed the Americans to use this precedent for *The Psychoanalytic Quarterly*, which was a competitor to his *International Journal*.

Publication went on, sometimes very irregularly, as attested by the fact that there were only three issues, rather than eight, for the year 1930–1931. It resumed under a new publisher, Denoël & Steele, in 1932. In 1939 only a single issue was published, with a new blue cover. It contained Freud’s “Analysis Terminable and Interminable,” translated by Ann Berman.

Publication of the journal was interrupted for eight years, despite John Leuba’s announcement to Jones on December 31, 1944: “I have prepared two complete issues of the journal of psychoanalysis. Our printer has disappeared. We need to study the issue of a publisher. In any case, it would be impossible for us to publish until several months from now, since owing to the shortage of paper the number of journals that are authorized for publication is extremely limited.” The princess, on her side, explained to Loewenstein on July 2, 1945: “As for the *Revue*, I can no longer support it, either. Besides, it never really took off. Perhaps Rodker could start up a journal in London that would revive *Imago* in three languages, where we could publish our articles in French. The only risk would be problems with Jones, who only wants his English journal with ultra-Kleinian articles” (Bertin). Negotiations for the journal’s resumed publication with the Presses Universitaires de France took place only in 1947.

In fact, beginning with volume eleven, published in 1948, the SPP took over the publication of its “official organ,” underwritten by means of systematic subscription of its members. Authors gave up all potential royalties in exchange for disbursement by the publisher of a global sum intended to cover editorial costs. Despite discussions over the advantages and disadvantages of contracts that were renegotiated over time, the journal became sufficiently profitable to ensure its ongoing publication.

During the split of 1953, no disputes arose over the journal, which remained in the hands of the SPP and unfailingly published all information that was unfavorable to its competitor, the Société française de psychanalyse (SPF; French Psychoanalytical Society). It also disseminated the works arising out of rivalries with the secessionists, and owing to its regular publication—something other groups could not achieve—it became the most stable reference work of French psychoanalytic thinking during these decades.

Of anecdotal interest is the fact that in April 1960, at the age of seventy-eight, the indefatigable Bonaparte had a telegram sent to herself “accrediting her as a reporter for the *Revue française de psychanalyse*,” in order to visit Caryl Chessman in his cell prior to his execution, which she tried in vain to prevent (Bertin).

In the 1960s the problem arose of how to handle the publication of the proceedings of the Congress of Romance-Language Speaking Psychoanalysts, which the journal had undertaken from the outset. The growing importance of these proceedings had inflated the number of pages required for them, and a series of solutions were found. From 1961 to 1964 the congress proceedings were printed in a separate volume, but this practice was not maintained. Just as ineffective was the reiterated wish of the Teaching Committee of the Institute of Psychoanalysis that “the number of pages of the reports and papers hereafter be limited.” Denise Braunschweig and Jean Kestenberg obtained permission from the Presses Universitaires de France to return to the practice of publishing the proceedings in a special number of the journal. The value of this publication as a reference work must be underscored; each year it treats in depth a well-defined theoretical or practical point, and, beyond its historical perspective, inaugurated during the 1951 Congress with Daniel Lagache’s report on transference, it offers readers a broad spectrum of research and discussions. Since 1991 the *Bulletin de la S.P.P.*, created in October 1982 by Michel Fain, has undertaken advance publication of reports and papers.

After Maurice Bénassy’s resignation as editor of the *Revue française de psychanalyse* in April 1969, Christian David, Michel de M’Uzan, and Serge Viderman were chosen by the tenured members of the society in January 1970, in an informal vote, to take over editorship of the journal, with Jacqueline Adamov as copy editor. They attempted to make the journal more inde-

pendent of the SPP so that it would not appear to be a mere scientific brochure, but rather a publication unto itself. Their effort, from 1970 to 1975, to have the phrase “Official Organ of the S.P.P.” changed to “Published under the aegis of,” if it had the merit of raising the issue of a separation of objectives, was called into question during negotiations for a new contract with the Presses Universitaires de France. Beginning with the first issue of 1976, the words “Official publication of” reappeared. Overall it continued to run at a deficit, despite undeniable editorial success: In November 1977, there were 2,382 subscriptions, 684 of these from foreign subscribers, plus 1,022 copies sold by the issue.

In March 1980, Jean Gillibert, Claude Girard, and Evelyne Kestenberg were named co-editors. They in turn experienced problems and resigned three years later. They were held responsible for a decrease in subscriptions, even though the total readership had increased. They cited as a reason for the decrease in subscriptions the competition of the *Bulletin de la S.P.P.*, which nevertheless was the response to their often-expressed wish to be relieved of the burden of systematically publishing lectures and administrative information.

The idea of thematic issues seemed sound, as Claude Le Guen stressed in May 1983. After proposing his own candidacy, he left the new editorship of the journal to a team made up of Ilse Barande, Claude Girard, Marie-Lise Roux, and Henri Vermorel. They remained on the job beyond their mandate, which ended in 1986, and were replaced only in February 1988.

The merger of the SPP and its Institute of Psychoanalysis had taken place two years earlier when André Green, then president of the SPP, announced on July 8, 1988: “The Board of Directors has entrusted the editorship of the *Revue* to Claude Le Guen. The new editor has presented to the Board of Directors the new policy he intends to implement. Articles published by the journal will be divided into two categories, each of which will be entrusted to an adjunct editor. One category, headed by J. Cornut, will bring together publications and articles of a scientific nature. The other, headed by G. Bayle, will bring together publications of a more topical, critical, or even polemical nature, as well as those focused on training: clinical, technical, or theoretical points, in the form of regular columns. The editorial staff will also include J. Adamov, C. Athanassiou, J. J. Baranès, J. Begoin, T. Bokanowski, P. Denis,

M. Gibeault, C. Janin, R. Menahem, J. F. Rabain, J. Schaeffer, H. Troisier. The first issue of the R.F.P. produced by the new team will appear in October 1988 with a new format and a new cover design.”

The choice of presenting thematic issues definitively prevailed and led to a marked increase in the readership of this journal, which is both the oldest and the most widely read French psychoanalytic journal. The same year, 1988, Le Guen, assisted by Gilbert Diatkine, also created the “Monographies de la R.F.P.” (Monographs of the R.F.P.), a series in which each volume, focused in a specific theoretical or practical issue, was a sure-fire editorial success. “Débats en psychanalyse” (Issues in psychoanalysis), with Jacqueline Schaeffer as adjunct editor, was created in 1995 for the purpose of publishing papers from colloquia and scientific meetings, which the *Bulletin* could no longer handle on its own.

Since 1996 Paul Denis, creator of the series “Psychanalystes d’aujourd’hui” (Psychoanalysts of today), has been the editor of the *Revue française de psychanalyse*.

ALAIN DE MIJOLLA

See also: France; Société psychanalytique de Paris and Institut de psychanalyse de Paris.

### Bibliography

- Bertin, Célia. (1982). *Marie Bonaparte, a life*. New York: Harcourt Brace Jovanovich.
- Bourgeron, Jean-Pierre. (1993). *Marie Bonaparte et la Psychanalyse à travers ses lettres à René Laforgue et les images de son temps*. Geneva: Champion-Slatkine.
- Freud, Sigmund, and Laforgue, René. (1977h [1923–33]). Correspondance Freud-Laforgue, préface d’André Bourguignon. *Nouvelle Revue de psychanalyse*, 15, 235–314.
- Mijolla, Alain de. (1991). Le Congrès des psychanalystes de langue française des pays romans: Quelques éléments d’histoire. *Revue française de psychanalyse*, 55 (1), 7–36.
- . (1992). France (1893–1965). In P. Kutter (Ed.), *Psychoanalysis International: 4 Guide to Psychoanalysis throughout the world*, (Vol. 1; pp. 66–113). Stuttgart: Frommann-Holzboog.

## RICHARD, CASE OF

Melanie Klein’s case of Richard is published in two forms: (a) “The Oedipus complex in the light of early anxieties” (Klein, 1945) and (b) *Narrative of a Child Analysis* (published posthumously, Klein, 1961).

In 1939, Klein moved out of London because of the war, and settled eventually in the small Scottish town of Pitlochry between June 1940 and September 1941. She used this time, away from colleagues, to reflect on her work; to plan further writing, especially on technique, and to conduct an exemplary analysis of a 10-year-old boy, Richard, six sessions each week from April to August 1941. She kept process records of the play and conversations—for example, Richard’s associations, and Klein’s interpretations of them—during each of the sessions.

The theoretical conclusions from this case, especially about the early form of the Oedipus complex in a boy, were presented as a paper in 1945.

The book, *Narrative of a Child Analysis*, is a detailed presentation of the case. The ten-year-old boy Richard was treated in 1941. Each of 93 sessions is described in a brief process record, and each is followed by a commentary written much later, just before Klein’s death in 1960. It was intended as a supplement to her early book *The Psycho-Analysis of Children*, and to present her technique in detail. The fact that it was not published for nearly 20 years is due to a number of reasons, including the fact that her interests had moved on to the urgent need to present her developing theoretical conclusions. But Klein believed this record represented her technique at the time and that it had not changed very much by the time the record was published.

She wrote this case history for presentation as a paper, “The Oedipus complex in the light of early anxieties,” to the British Psycho-Analytical Society in 1945. It is a very detailed account of the early stages of the Oedipus complex as it had emerged in her early work with children, and then subsequently revised in the light of her theory of the depressive position which she had described five years before. She believed this significantly added to Freud’s descriptions of the Oedipus complex, though she was clear that it did not replace Freud’s work.

As far as the boy’s complex is concerned, development through the Oedipal conflicts is propelled not only by the boy’s fear of castration from his vengeful father, but the boy’s love for his father and wish to protect him from his own damaging hatred. As to the little girl, she concluded that Freud was only partly right in his notion of penis envy, which he over-rated. More prominently, the little girl is occupied by the phantasy

of father's penis residing inside mother with the future babies there. The little girl is as preoccupied with the desire for father's penis inside her, and her internal babies, as she is with the hopeless wish for a penis of her own. The anxiety that little girls suffer most is therefore the fear of a retaliatory mother arising out of the girl's wish to steal the penis from inside her mother. Her conclusions were not new and are found in her earlier book (Klein, 1932).

Klein's wish to write a thorough account of her technique was only partly realized in a paper in 1955 on "The Psycho-Analytic Play Technique: Its History and Significance." Towards the end of her life she returned to the full set of process notes she had made of Richard's analysis, and began the task of annotating every session. She completed this just before her death, and the work was published a few months later as *Narrative of a Child Analysis*. This was her very last word on child analysis and is a major statement on her technique.

What the book does is to explore in careful detail the ways in which these configurations of objects are worked out for the 10-year-old boy in an analytic setting. In particular she concentrates carefully on the location of the objects; felt by the boy to be inside him, often accompanied by physical sensations, or in the external world and represented by actual things and people which interact in ways that make them suitable to incorporate into his play, his phantasies, and his dialogue.

The book is of fascinating and major interest for its portrayal of a child analysis in detail. It is written with considerable poignancy and charm, and with an obvious affection for Richard, a frightened but quite courageous little boy. At the time it attracted great interest because it revealed Klein at work, and it has remained an important complement to her often complex theoretical writings.

By the time she published her first account of Richard, in 1945, the technique employed by Klein and her colleagues was about to change in significant ways as she and her colleagues explored the fragmented and part-object world of schizoid and schizophrenic patients. Technical aspects of Anna Freud's method of child analysis had also changed by this time (Geleerd, 1963).

ROBERT D. HINSHELWOOD

*See also:* Phobic neurosis.

### **Bibliography**

- Geleerd, Elisabeth R. (1963). Evaluation of Melanie Klein's narrative of a child analysis. *International Journal of Psychoanalysis*, 44, 493–506.
- Klein, Melanie (1932). *The psycho-analysis of children*. London: Hogarth.
- . (1961). *Narrative of a child analysis*. London: Hogarth.

---

### **RICKMAN, JOHN (1880–1951)**

John Rickman, a doctor of medicine, psychiatrist, and psychoanalyst, was born on April 10, 1880, at Dorking, Surrey, England, and died on July 1, 1951, in Regent's Park, London. He was the only child of Quaker parents, and his father died when he was two. He went to Leighton Park, a Quaker boarding school in Reading. He fulfilled the requirements of a Natural Science Tripos at the University of Cambridge, and he completed his medical degree and qualified in 1916 at St. Thomas's Hospital in London. He joined the Friends War Victims Relief Unit in Russia (Rickman, 1949). In 1918 he met and married Lydia Lewis, an American. He then studied psychiatry at Cambridge, where Dr. William H. R. Rivers advised him to see Freud in Vienna. Freud agreed to see him for two guineas.

Freud asked him to work on what was published as *The Development of the Psycho-Analytical Theory of the Psychoses* (Rickman, 1928a). He returned to London and was elected an associate member of the British Psycho-Analytical Society in 1920 and a member in 1922. He played a key role in the early years of the society and its Institute of Psycho-Analysis, especially in administration, publication activities, and links with allied professions. In this regard, it was particularly helpful that he was an editor of the *British Journal of Medical Psychology* for 14 years.

He was elected to the council and to the first training committee in 1926. In 1929 he went to Budapest to have analysis with Sándor Ferenczi, and later, prior to the Second World War, he underwent some analysis with Melanie Klein and supported her approach.

After 1936 the Spanish Civil War convinced him of the need to oppose the Nazis. He was often asked to write editorials for *The Lancet* during periods of politi-



cal crisis. In 1939 he joined the Emergency Medical Services, later becoming a major in the Royal Army Medical Corp. He met Wilfred R. Bion when he worked in Wharncliffe and Northfield Hospitals. He was then posted to the British Army War Officer Selection Board to select officers. Impressed by his approach, some colleagues later applied to be trained as psychoanalysts.

After the war he took an active part in the British Psycho-Analytical Society and in its new training arrangements. He also facilitated the rapprochement between the Tavistock Clinic and the society. In 1948 he was elected president of the society. At that time he was considered a member of the Middle Group, not a Kleinian. His thoughts as president are contained in his seminal paper on the functions of a psychoanalytic society (Rickman, 1951).

In 1928 he published *The Development of the Psycho-Analytical Theory of the Psychoses, 1893–1926* and also *Index Psycho-Analyticus*. He edited the Psychoanalytical Epitome Series and wrote over a hundred papers and reviews. In 1957 his *Selected Contributions to Psycho-Analysis* was published.

His early death in 1951 was a loss to the British Psycho-Analytical Society, which missed his ability to act as a bridge between colleagues in other disciplines and analysts exploring the contributions that psycho-analysis could make to the understanding of group relations and the structure of society.

PEARL H. M. KING

See also: Great Britain; Group analysis; *International Journal of Psychoanalysis*, *The*; Tavistock Clinic.

### Bibliography

Rickman, John. (1928a). *The development of the psycho-analytical theory of the psychoses, 1893–1926*. London: Bailliere, Tindall & Cox.

———. (1928b). *Index psycho-analyticus, 1893–1926*. London: Hogarth Press and the Institute of Psycho-Analysis.

———. (1949). Sketches of Russian peasant life (1916–1918). In Geoffrey Gorer and John Rickman (Eds.), *The peoples of greater Russia: A psychological study* (pp. 23–89). London: Cresset.

———. (1951). Reflections on the functions and organization of a psycho-analytical society. *International Journal of Psychoanalysis*, 32, 218–237.

———. (1957). *Selected contributions to psycho-analysis*. London: Hogarth Press and the Institute of Psycho-Analysis.

## RIE, OSKAR (1863–1931)

The Austrian pediatrician Oskar Rie, friend and physician to Freud and his family, was born on December 8, 1863, in Vienna, where he died on September 17, 1931.

The Ries were a Jewish family from Prague; Isidor Rie was a gem merchant. Oskar, the second of five children, studied in Vienna and received his medical degree in 1887.

Rie was one of Freud's most faithful friends. From 1886 to 1896 he served as Freud's assistant at the Kassowitz Institute in Vienna (*Öffentliches Kinder-Krankeninstitut*), where Freud held consultations in pediatric neurology several times each week. Together they published a monograph on cerebral palsy in children, *Klinische Studie über die halbseitige Cerebrallähmung der Kinder* (Clinical study of cerebral paralysis of children [1891a]), which won considerable influence and insured Freud's reputation as a specialist. Rie also served as family physician to Freud's children and sister-in-law Minna Bernays. While often acknowledging his devoted friendship, Freud viewed Rie with antagonism around the end of his friendship with Wilhem Fliess.

In the psychoanalytic literature Rie is known above all for his appearance as "Otto" in Freud's famous "dream of Irma's injection" in *The Interpretations of Dreams* (1900a). In the manifest dream, he is Freud's friend and the doctor who injected the patient with "a preparation of propyl, propyls ... propionic acid ... trimethylamin" (Freud 1900a, p. 140)—that aggravated her condition. Free associations clearly indicated Freud's ambivalence toward Rie, who was also taken to task in correspondence with Fliess. Freud took Rie's resentment concerning the revelations in *The Interpretation of Dreams* and "his lack of understanding for my findings" (Freud 1985, p. 447) to be another illustration of his observation that "[a]n intimate friend and a hated enemy have always been indispensable to my emotional life; I have always been able to create them anew, and not infrequently my childish ideal has been so closely approached that friend and enemy have coincided in the same person; but not

simultaneously, of course, as was the case in my early childhood” (1900a, p. 483).

But Rie would remain a close friend. He accompanied Freud on vacations in the mountains, including the sojourn at the Alpine retreat where Freud “treated” Katharina, one of the cases presented in *Studies on Hysteria*. Rie instructed Fliess (his brother-in-law) to insist that Freud stop smoking. On Saturdays, he played tarok with Freud and his brother Alfred, and often accompanied Freud to the theater. On January 5, 1898, together they saw Theodor Herzl’s play *The New Ghetto*, then later met Herzl at a meeting of B’nai B’rith, of which he became a member in 1901, the same year as Alexander Freud.

A member of the Wednesday Evening Society, Rie was admitted to the Vienna Psychoanalytic Society on October 7, 1908, at the same time as Sándor Ferenczi, and numerous traces of his presence can be found in the Society’s minutes.

Rie’s marriage to Ida Fliess’s sister, Melanie Bondy, on November 10, 1896, generated further connections in the history of psychoanalysis. In addition to a son, Norbert (b. Oct. 30, 1897), his daughter Margarethe (b. March 25, 1899) would marry Hermann Nunberg in 1929 and be analyzed by Freud in the 1920s (about the same time as her friend, Anna Freud). Marianne (born May 27, 1900) would marry Ernst Kris in 1927 and become a well-known analyst in the United States. Especially known for her work in psychoanalysis with children, among her adult patients were Marilyn Monroe and Diana Trilling; one of her closest friends was Anna Freud.

On August 4, 1921, Freud wrote to Rie: “Your friendly words about me have done me good although they didn’t tell me anything new because I have been looking upon your friendship for more than a lifetime as an assured possession. I have been able to give something to many people in my life; from you fate has allowed me only to receive” (Freud 1960, p. 335).

ALAIN DE MIJOLLA

See also: Institute Max-Kassowitz; Kris-Rie, Marianne.

### Bibliography

Freud, Sigmund, and Rie, Oskar. (1891a). *Klinische Studie über die halbseitige Cerebrallähmung der Kinder*. Vienna: Moritz Perles.

Nunberg, Herman, and Federn, Ernst (Eds.). (1962–1975) *Minutes of the Vienna Psychoanalytic Society*, Vol. I, 1906–1908; Vol. II, 1908–1910; Vol. III, 1910–1911; Vol. IV, 1912–1918. New York: International Universities Press.

## RITE AND RITUAL

Rites and rituals have been studied from antiquity: Western philosophers pondered these practices, which in modern times have become an object of study in anthropology, ethnology, and sociology. The diversity of practices makes an authoritative definition problematic, but certain general descriptors apply: A rite is a well-ordered, obligatory action or group of actions that is performed precisely and repetitively; it often moves to an individual or collective rhythm; its meaning and aims are generally opaque, and of no obvious practical purpose. Rites and rituals are related to the sacred: religion, magic, purification, and so forth—the notion of the rite of passage remains in use. Sigmund Freud’s writings on the ritual can be included among the great variety on the subject, although, but he privileges the German word *Zeremoniell*, meaning ceremonial or ceremonious; in so doing, he underscores the sacred character of these practices.

From 1894 to 1896 Freud developed the idea of obsessional neurosis. In “Further Remarks on the Neuro-Psychoses of Defence” (1896b), in the context of the trauma theory, he interpreted the ceremonials it can entail. These derive from the idea of obsessive actions, which are among the defenses and result from repression. Freud cited ceremonials associated with the anal zone and with infantile masturbation in, respectively, *Three Essays on the Theory of Sexuality* (1905d) and the case of Dora, related in “Fragment of an Analysis of a Case of Hysteria” (1905e [1901]). The article “Obsessive Actions and Religious Practice” (1907b) was devoted to this topic and, according to Freud’s “Short Account of Psycho-Analysis” (1924f [1923]), marked the beginning of his work on religious psychology. The deepening of the analogy of the dynamics between obsessional neurosis and collective ritual practices, by way of the notion of primal ambivalence and its expression toward the father, in *Totem and Taboo* (1912–13a), is the basis for Freud’s perspective on individual and collective ceremonials.

In “A Short Account of Psycho-Analysis,” written in 1923, Freud presented this study in a broad context: “If

the psychological discoveries gained from the study of dreams were firmly kept in view, only one further step was needed before psycho-analysis could be proclaimed as the theory of the deeper mental processes not directly accessible to consciousness—as a ‘depth-psychology’—and before it could be applied to almost all the mental sciences. This step lay in the transition from the mental activity of individual men to the psychical functions of human communities and peoples—that is, from individual to group psychology; and many surprising analogies forced this transition upon us... To take an instance... It is impossible to escape the impression of the perfect correspondence which can be discovered between the obsessive actions of certain obsessional patients and the religious observances of believers all over the world. Some cases of obsessional neurosis actually behave like a caricature of a private religion, so that it is tempting to liken the official religions to an obsessional neurosis that has been mitigated by becoming universalized. This comparison, which is no doubt highly objectionable to all believers, has nevertheless proved most fruitful psychologically. For psycho-analysis soon discovered in the case of obsessional neurosis what the forces are that struggle with one another in it till their conflicts find a remarkable expression in the ceremonial of obsessive actions. Nothing similar was suspected in the case of religious ceremonial until, by tracing back religious feeling to the relation with the father as its deepest root, it became possible to point to an analogous dynamic situation in that case too” (pp. 205–206).

In the *Introductory Lectures on Psychoanalysis* (1916–17a [1915–17]), after noting an economic difference between ceremonials in obsessional neurosis and those of communities, the former expressing a defense against repressed sexuality and the latter against narcissistic and aggressive impulses, Freud granted the importance of “extremely strong sadistic impulses” in obsessional neurosis. The taboo against touching, whether actual or metaphoric, that is evident in the phenomenology of ceremonials thus becomes intelligible. In fact, the fundamental theme of any ritual having to do with “touching” is the “first aim of object-cathexis, whether aggressive or tender,” wrote Freud in *Totem and Taboo* (1912–13a). If we add that the psychic position necessary for any ritual is narcissistic, or animistic from the collective point of view, and that it presupposes the omnipotence of wishes and thoughts, it becomes apparent that the underlying obsession in any ceremonial is that of the

contagion of instinctual impulses; this explains the prevalence of magical actions and thoughts having to do with contagion—by contiguity, similarity, isolation, and retroactive annulment.

Throughout his writings Freud described and gave a detailed analysis of various rituals: scatological, money-related, rituals of washing, for going to sleep, or for beginning something. Collective rituals such as those governing relations between son-in-law and mother-in-law, rituals relating to the dead, to chiefs or enemies who have been killed, and rituals relating to defloration and marriage have been extensively studied, in addition to the totemic meal and its repetition in the Christian sacrament of Communion, based on the idea of the murder and consumption of the primal father of the horde.

Ceremonials, as compromise formations, presuppose a repression, and the primary processes thus play a part in their creation. Displacement and the condensation of a multiplicity of fantasies in the ceremonial lead to overdetermination; an absence of contradiction that enables the ceremonial to actualize both wish and defense. In addition, the abundance of symbolism is unmistakable. From an economic point of view, the pleasure principle prevails, and Freud emphasized the sexual excitation that occurs during ceremonials. In *Inhibitions, Symptoms and Anxiety* (1926d) Freud explained that from a topographical and dynamic point of view, regression, linked to powerful aggressive impulses, results in “the erotic trends being disguised” and that accordingly, “the struggle against sexuality will hence-forward be carried on under the banner of ethical principles” (p. 116). The ego “recoils in astonishment” from suggestions of cruelty emanating from the id, and “[t]he overstrict superego insists all the more strongly on the suppression of sexuality, since this has assumed such repellent forms” (p. 116). The theme of guilt is omnipresent, which phenomenology alone reveals, as is the theme of punishment. There is thus continuity between ceremonials and taboos. Moreover, the persistence of unconscious wishes and their fulfillment in ceremonials, no matter what the defenses have undertaken, provokes excessive scruples in their enactment and systematic doubt as to their propriety. The ceremonial’s common compulsion to repeat seems to depend on the same factors.

In *Inhibitions, Symptoms and Anxiety*, written in 1925, Freud lamented the fact that “no one has as yet collected [ceremonials] and systematically analysed

them” (p. 116). With regard to their emergence, often during the latency period, he noted: “Why this should be so is at present not at all clear; but the sublimation of anal-erotic components plays an unmistakable part in it” (p. 116). Sublimation remains a lively issue in psychoanalysis. The compulsion to repeat, as linked to the death instinct and to masochism, is another. Lastly, the generalization of the obsession with touching or not touching, in our ostensibly secular culture, seems more misunderstood than acknowledged. Thus, ceremonies, rites, and rituals are an area that awaits further study.

MICHÈLE PORTE

*See also:* Framework of the psychoanalytic treatment; Myth of origins; Religion and psychoanalysis; Sadism; Symptom.

### **Bibliography**

- Freud, Sigmund. (1912–13a). Totem and taboo. *SE*, 13: 1–161.
- . (1916–17a [1915–17]). Introductory lectures on psycho-analysis. Part I, *SE*, 15; Part II, *SE*, 16.
- . (1924f). A short account of psycho-analysis. *SE*, 19: 189–209.
- . (1926d). Inhibitions, symptoms and anxiety. *SE*, 20: 75–172.
- Reik, Theodor. (1975). *Ritual: Psycho-analytic studies* (Douglas Bryan, Trans.). Westport, CT: Greenwood Press. (Original work published 1949)
- Van Gennep, Arnold. (1960). *The rites of passage*. (M. B. Vizedom and G. B. Caffee, Trans.). Chicago: University of Chicago Press. (Original work published 1909)

## **RITTMEISTER, JOHN FRIEDRICH KARL (1898–1943)**

John Rittmeister, a German neurologist and psychoanalyst, was born in Hamburg on August 21, 1898, and was guillotined in Plötzensee prison, outside Berlin, on May 13, 1943. The last of three children in a long-established and well-to-do family of merchants, he studied the humanities before joining the armed forces in 1917 during World War I and serving on the Italian and French fronts. From 1920 to 1925 he studied medicine at the universities of Göttingen, Kiel, and

Hamburg. He specialized in neurology with Max Nonne and received his state doctorate at Hamburg. After three years of neuropsychiatric training in the hospitals of Munich, he began practicing psychotherapy there. He gave conferences and demonstrations of hypnosis and familiarized himself with the teachings of Carl Gustav Jung.

In 1929 he settled in Zurich, staying there for two years before acquiring a post as a voluntary physician at the polyclinic for nervous diseases of the Burghölzli Psychiatric Clinic, under the directorship of Erich Katzenstein, where he also conducted neurological research. From 1935 to 1937, with a few interruptions, he worked as an assistant psychiatrist at the Münsingen cantonal hospital under Max Müller, where he developed an excellent personal and philosophical relationship with senior lecturer Alfred Storch, who had been driven out of Germany.

During his stay in Switzerland, he joined socialist groups for students and workers, went on a study trip to the Soviet Union, and became a convinced Marxist, for which the Swiss authorities often threatened to deport him. In Zurich he quickly distanced himself from Jung’s psychology club because of its “suffocating, mystical and obscure atmosphere.” He explained his position in a scientific lecture titled “Voraussetzungen und Konsequenzen der Jung’schen Archetypenlehre” (The presuppositions and consequences of teaching Jungian archetypes; 1982). In 1922, while still a student in Munich, he sought psychological help from Hans von Hattingberg, and in 1935 he commenced his analysis with Gustav Bally in Zurich. In “Die psychotherapeutische Aufgabe und der neue Humanismus” (Psychotherapeutic duty and the new humanism), published in Holland in 1936, he advocated a comparison between the Freudian and Jungian schools and “a humanism of decision, which establishes joint, concrete goals.” He attacked, in a barely disguised way, the political situation of National Socialist Germany, and he returned to this theme at the end of 1937.

In Berlin he was chief medical officer in a psychiatric clinic. He trained in psychoanalytic work group A of the Göring Institute, more formally known as the Deutsches Institut für psychologische Forschung und Psychotherapie (German Institute for Psychological Research and Psychotherapy), doing his training analysis with Werner Kemper. After he married Eva Knieper in July 1939, he obtained a position in the

polyclinic in September and later became its director. He played an active part in the scientific life of the Göring Institute, giving lectures and conferences for candidates. His report on the current state of the polyclinic appeared in the *Zentralblatt für Psychotherapie* in 1941, and his last conference in the spring of 1942, “Die mystische Krise des jungen Descartes” (The mystical crisis of the young Descartes) was published as late as 1961, when it appeared in *Confinia psychiatria*.

During the last years of his life in Berlin, he gathered around him a circle of young people (mainly his wife’s fellow students), teaching them philosophy and politics and organizing them to help Jews and foreign workers recruited by force. On Christmas 1941, with the help of Harro Schulze-Boysen, he managed to join the Red Orchestra, a resistance group organized around Schulze-Boysen and Arvid Harnack. Rittmeister participated in clandestine political work, designing and distributing pamphlets and propagandizing for foreign workers, but he did not spy for the Soviet Union, as was claimed. After being arrested on September 26, 1942, he was condemned to death by the war tribunal of the Reich, along with most of the members of his group, and was executed in May 1943.

LUDGER M. HERMANN

*See also:* Deutsches Institut für Psychologische Forschung und Psychotherapie (Institut Göring); Germany; Marxism and psychoanalysis; Second World War: The effect on the development of psychoanalysis; Kemper, Werner Walther.

### **Bibliography**

- Bräutigam, Walter. (1987). *John Rittmeister: Leben und Sterben*. Ebenhausen bei München: Langewiesche-Brandt.
- Hermanns, Ludger M. (1982). John F. Rittmeister und C. G. Jung. *Psyche*, 36, 1022–1031.
- Rittmeister, John F. (1936). Die Psychotherapeutische Aufgabe und der neue Humanismus. *Psychiatrische en neurologische Bladen*, 5, 777–796.
- . (1961). Die mystische Krise des jungen Descartes. *Confinia psychiatria*, 4, 65–98.
- . (1982). Voraussetzungen und Konsequenzen der Jungschen Archetypenlehre. *Psyche*, 36, 1032–1044.

———. (1992). *Hier brannte doch die Welt: Aufzeichnungen aus dem Gefängnis, 1942–1943* (Christine Teller, Ed.). Gütersloh, Germany: Jacob van Hoddis.

Schulz, Manfred. (1981). Dr. John Rittmeister, Nervenarzt und Widerstandskämpfer. Medical dissertation, Humboldt University, Berlin.

---

## **RIVALRY**

Etymologically, the word *rival* refers to people who live by the river and draw their water from the same stream. From a psychoanalytic point of view, rivalry is not simply a struggle for possession of the object, but can also be understood as having sexual, identificatory, and narcissistic aspects.

The ensemble of partial drives directed toward the mother, once she is perceived as an object that is differentiated from the self, is accompanied by hostile rivalry toward the father. This oedipal rivalry is extended to the hostile relationships that occur among siblings.

The object of rivalry can change in relation to bisexuality. Wishes for the rival’s death are repressed, and the formerly hated rival becomes a homosexual love-object. In “Neurotic Mechanisms in Jealousy, Paranoia and Homosexuality” (1922b), Sigmund Freud posited an analogy between this mechanism and the process that is the basis for social bonds: “In both processes, there is first the presence of jealous and hostile impulses which cannot achieve satisfaction; and both the affectionate and the social feelings of identification arise as reactive formations against the repressed aggressive impulses” (p. 232).

Freud thus attributed the decline of rivalry to repression, which results from the establishing of the superego and from the confrontation between hostile wishes and the child’s impotence.

Rivalry creates a link of ambivalence between the subject and an other who can always become the subject’s alter ego, because the object of desire is the same for both. Putting himself in the place of this other, the subject imagines himself as being dispossessed of a source of enjoyment (*jouissance*) that tolerates no sharing. The subject’s hatred is all the stronger because unconsciously, this struggle is for possession of an object that bears the narcissistic illusion of perfect continuity between self and other. The destructiveness of the tendency away

from differentiation is thus transformed into hatred and suspended through triangulation.

Rivalry, which tends toward repetition and acquires its various layers through reaction formations, is one component in the structuring of human desire.

STEVEN WAINRIB

*See also:* “Analysis of a Phobia in a Five-Year-Old Boy” (Little Hans); Anxiety; “Contributions to the Psychology of Love”; Counter-Oedipus; Dead mother complex; Examination dreams; Family romance; Forgetting; Masculine protest (individual psychology); Oedipus complex, early; Primitive horde; Wish for a baby; Wish/yearning.

### **Bibliography**

Freud, Sigmund. (1909c). Family romances. *SE*, 9: 235–241.

——— (1922b). Neurotic mechanisms in jealousy, paranoia and homosexuality. *SE*, 18: 221–232.

---

## **RIVIERE-HODGSON VERRAL, JOAN (1883–1962)**

British psychoanalyst Joan Riviere was born Joan Hodgson Verrall in Brighton, England, June 28, 1883, and died in London, May 20, 1962.

A founding member of the British Psycho-Analytical Society, she used her highly accomplished literary skills and sensitivity to meaning in her translations of Freud’s work and the writings of other psychoanalysts. As translation editor of the *International Journal of Psycho-Analysis* she was responsible for the translation of all papers from its inception in 1920 until 1937, after which she gave more time to her teaching and writing.

As a friend, colleague, and collaborator of Melanie Klein, she was an articulate proponent of Klein’s ideas, probably the most able among Klein’s colleagues to express her theories incisively and convey them with subtlety. Most important, Riviere contributed many original ideas to the body of psychoanalytical knowledge that was being developed during the more than 40 years of her professional life.

Her education was irregular, even for late Victorian times: school in Brighton, a seaside town in Sussex where she was born, was followed by some unhappy

years in a girls’ boarding school. Then, at 17, she spent a year in Gotha, Germany, where she gained the remarkable command of German that was to play such an important part in her translations.

She was married in 1906 to Evelyn Riviere, a barrister, and her only child, Diana, was born in 1908. In the following years she struggled to find a place in the professional world. She was involved in various movements for social change, such as divorce reform and suffragette activity. However these efforts did not alleviate the considerable emotional distress from which she suffered, and this led her to a therapeutic psychoanalysis with Ernest Jones in 1916. The latter was so impressed with her deep and sensitive understanding of psychoanalytic principles and processes that he made her a founding member of the British Psycho-Analytical Society, formed in 1919.

The analysis with Jones was difficult and, reaching an impasse, he recommended her to Freud for further psychoanalysis. This took place in 1922 with evident success. On her return to London from Vienna, Riviere became actively involved in the work of the British Psycho-Analytical Society, becoming a training analyst in 1930. She was the analyst of such well-known individuals as Susan Isaacs, John Bowlby, and Donald Winnicott. She was reported by those she supervised, such as Hanna Segal, Herbert Rosenfeld, and Henri Rey, to be an excellent supervisor.

Her original contributions to psychoanalysis are to be found in her papers: “Femininity as a Masquerade” (1929) examines an area of sexual development, in which the femininity of certain women is found to be the mask assumed to hide phallic rivalry and hatred of men. “Jealousy as a Mechanism of Defence” (1932) shows remarkable originality in that she finds jealousy to be a defense against envy aroused by the primal scene. Her most original work is “A Contribution to the Analysis of the Negative Therapeutic Reaction” (1936). In it she incorporates Klein’s findings on the depressive position, and describes for the first time the concept of a “defensive organization” as a protection against a psychic catastrophe. In the same year she showed her ability to put Klein’s theories in a context of Freud’s discoveries with “The Genesis of Psychological Conflict in Earliest Infancy,” delivered in Vienna in 1936 in honor of Freud’s 80th birthday. The richness of her thinking about our unconscious drives is apparent in the inner world in Ibsen’s “Master-Builder” (1952), where she describes how the forces

that shape the world find expression on the stage as in life.

ATHOL HUGHES

*See also:* British Psycho-Analytical Society; Controversial Discussions; Dependence; Feminism and psychoanalysis; Great Britain; Negative therapeutic reaction; *Standard Edition of the Complete Psychological Works of Sigmund Freud*.

### **Bibliography**

Riviere, Joan (1929). Womanliness as a masquerade. *International Journal of Psychoanalysis*, 10, 303–313.

———. (1932). Jealousy as a mechanism of defence. *International Journal of Psychoanalysis*, 13, 414–424.

———. (1936). A contribution to the analysis of a negative therapeutic reaction. *International Journal of Psychoanalysis*, 17, 304–320.

———. (1936). On the genesis of psychic conflict in earliest infancy. *International Journal of Psycho-Analysis*, 17, 395–422.

———. (1952). The inner world in Ibsen's "Master Builder." *International Journal of Psycho-Analysis*, 33, 173–180.

---

## **RIVISTA DI PSICOANALISI**

*La Rivista di psicoanalisi* has been the official organ of the Italian Psychoanalytic Society (SPI) since 1955, when this quarterly review was first published. Each volume contains approximately 180 pages, for a total of 720 to 760 pages per year. The articles are organized by section: theory and clinical practice, current issues ("Reflections on Psychoanalysis and Science"), ethics, technique, and social issues ("Beyond the Couch"), discussions of work in progress, reports of congresses and meetings, reviews, reports of foreign-language publications, reviews of studies and trials, and obituaries.

Since being founded in 1925 and its subsequent revivals (1932 and 1945), the SPI has always attempted to publish a review that would serve as an instrument of scientific understanding and the diffusion of knowledge. In 1925, professor Marco Levi Bianchini, the society's founder, transformed the review he had created in 1920, *Archivio generale di neurologia e psichiatria*, into the official publication of the SPI with the

title *Archivio generale di neurologia, psichiatria e psicoanalisi*. In 1938 Italy's racial legislation forced him to sell the publication to Agostino Gemelli, who changed the title to *Archivio di neurologia, psichiatria e psicoterapia*.

After re-establishing the SPI in 1932, Edoardo Weiss provided it with a new official publication, the *Rivista italiana di psicoanalisi*, the first issue of which was published that same year. The Fascist government suspended publication, and the first issue of 1934, which had already been printed, was never distributed. In addition to articles by Edoardo Weiss, Nicola Perrotti, and Emilio Servadio, the first issue contained contributions from foreign authors including Heinrich Meng, Ernest Jones, Franz Alexander, Ludwig Jekels, Paul Federn, Sophie Morgenstern, Sigmund Freud ("The Moses of Michelangelo," 1914b), and Marie Bonaparte. Two other articles defended psychoanalysis against the attacks of the literary critic Francesco Flora and the philosopher Guido De Ruggiero. The second volume published Sigmund Freud's *New Introductory Lectures on Psychoanalysis* (nos. 29–35), along with contributions by Weiss and Servadio, and two articles by Cesare Musatti.

*La Rivista di psicoanalisi*, which has primarily promoted Italian authors, has also published several special issues: "Psychoanalysis of Psychiatric Institutions" (1971), "Aggression" (1972), "Interpretation" (1974), "Creative Processes" (1975), "Wilfred R. Bion" (1981). In 1986, in a supplement to volume 32, there appeared a general index covering the years 1932–1933 and 1955–1984, which provided information on authors, titles, and keywords.

ROSARIO MERENDINO

*See also:* Italy.

### **Bibliography**

*La Rivista di psicoanalisi* (1986). *Supplemento al numero 2: General index 1932–1933; 1955–1984*.

---

## **ROBERTSON, JAMES (1911–1988)**

A psychoanalyst, filmmaker, and influential researcher at the Tavistock Clinic on the impact of early separation on child development, James Robertson was born in Rutherglen, Scotland, on March 22, 1911, and died in London on December 31, 1988.

Robertson was the eldest child of five in a working-class Scottish family, and left education at 14 to work in a Glasgow steelworks. From 19 to 27 years of age he attended various part-time Glasgow University Extension Courses on literature, history, economics, and philosophy, and in 1939 spent a year at Fircroft College for the Higher Education of Working Men in Birmingham, studying the humanities. From 1941 to 1945 he studied for the External Diploma in Social Studies at London University. In 1946–47 he completed the Mental Health Certificate at the London School of Economics. He trained in the British Psychoanalytical Society, attaining associate membership in 1952, and full membership in 1970. Robertson met his future wife and colleague, Joyce, while studying in Birmingham. A Quaker, he registered as a conscientious objector during the war, and joined his wife to work with Anna Freud as the only male social worker at the Hampstead War Nurseries. He was accepted for psychoanalytic training on the recommendation of Anna Freud, being analyzed by Barbara Lantos.

In 1948 he joined John Bowlby at the Tavistock Clinic to do research on the effects on separation from the mother in early childhood. This research was conducted in children's hospital wards at the time when national policy was weekly visits. He could not forget the unnecessary unhappiness of the children and was concerned at the time that harm was being done. He and his wife made a series of important films illustrating these effects vividly, and actively campaigned for change. Later films, about institutionalization, foster care and substitute mothering, were influential in promoting the use of fostering rather than children's homes.

Robertson's untiring campaigning over 30 years was critically important in changing the United Kingdom National Policy on recognizing and meeting the emotional needs of children in hospital. Parents are now expected to stay with their young children in hospital. The vivid illustration on film of increasing disturbance in young children separated from their families initially shocked many pediatricians and nurses, and Robertson came under attack, but finally, following the first two films, the Platt Report in 1959 recommended that practice should change. In the 1960s, the National Association for the Welfare of Children in Hospital was formed, with the help and support of both Robertson and his wife. Robertson's pioneering use of film has been developed using video,

particularly by those in the field of attachment, and in recent studies of infant and child development.

JENNIFER JOHNS

*See also:* Tavistock Clinic.

### **Bibliography**

- Robertson, James. (1953). *A two-year-old goes to hospital*. London: Robertson Centre and Ipswich, Concord Films Council.
- . (1958). *Going to hospital with mother*. London: Robertson Centre and Ipswich, Concord Films Council.
- . (1958). *Young children in hospital*. London: Tavistock Publications.
- . (1976). *Young children in brief separation, series of five*. London, Robertson Centre and Ipswich, Concord Films Council.
- . (1989). *Separation and the very young*. London: Free Association Books.

---

## **RÓHEIM, GÉZA (1891–1953)**

Anthropologist and psychoanalyst Géza Róheim was born in Budapest on September 12, 1891, and died in New York on June 7, 1953.

Born to a prosperous family of Jewish merchants, as a child Géza had a passion for folk tales and while a high school student he delivered a paper before the Hungarian Ethnological Society. At the University of Budapest he studied geography, linguistics, philosophy, law, and literature; then, in Berlin and Leipzig, anthropology and the history of religion. Because anthropology was not yet a fully developed discipline, when he received his doctorate in 1914 his examination was in geography. As an assistant librarian in 1917 in the Széchenyi Library of the Hungarian National Museum, Róheim essentially specialized in folklore. In 1918 he married Ilona, who would become his partner in anthropological research.

Róheim had become acquainted with psychoanalysis while a student, and his first article "Dragons and Dragon Killers," published in 1911, brought a psychoanalytic perspective to the explanation of myths. In 1916 he began analysis, first with Sándor Ferenczi and later with Vilma Kovács. In *Spiegelzauber* (Mirror Magic), first



published in 1919, Róheim made extensive use of Freud's recently developed theory of narcissism.

During Béla Kun's short-lived communist revolution in 1918, Róheim helped reorganize the Hungarian National Museum, where he held the first chair of anthropology at the University of Budapest. But when the regime failed after just three months, Róheim lost his academic position. Henceforth he made a living through analytic practice and by giving occasional courses in English.

In 1921, Róheim received the Freud Prize for his study "Das Selbst" ("The Self") and for his paper on Australian totemism delivered at The Hague Congress in 1920. In 1927, when Bronislaw Malinowski famously contested the existence of the Oedipus complex in matrilineal societies, Róheim had the task of gathering material to refute the ethnologist's arguments. Several expeditions, beginning in 1928 and sponsored by Marie Bonaparte, enabled Róheim to do field work in Central Australia, New Guinea, Normanby Island, and in Arizona among the Yuma.

From this work in the field Róheim developed his major themes. In 1932 he published "Psychoanalysis of Primitive Cultural Types" and arguably his central work, *The Riddle of the Sphinx*, appeared in 1934. He emphasized the significance of the primal scene and, relying on work in comparative anatomy by German physiologist Ludwig Bolk, attempted to demonstrate the role of fetal characteristics in human mental life, which he believed had important and to some extent pathogenic consequences.

In the autumn of 1938, after the rise of fascism and with war fast approaching, Róheim emigrated to the United States. He first settled in Worcester, Massachusetts, where he practiced as a psychoanalyst at the State Hospital for the Insane; he subsequently settled in New York. As a non-medical analyst, Róheim was not accepted into the New York Psychoanalytic Society, nor could he find an academic appointment. His work, based on a systematic human psychology, found little support among the functionalist ethnologists then predominant in the universities, while he himself remained critical of cultural anthropology. Ever creative and intrepid, Róheim organized a seminar in his home that brought together, among others, anthropologists Weston La Barre, Werner Münsterberger, and Georges Devereux. In 1947, he undertook a new expedition among the Navajo.

Róheim left a considerable body of work that includes some one hundred fifty studies and a dozen books on a host of topics in anthropology, sociology, history, mythology, folklore, and psychoanalysis. To him is owed a method of applied psychoanalysis buttressed by field investigation. He developed an ontogenetic theory of culture and, citing Ferenczi, he contended that a foundational trauma lies at the root of each culture. Also, influenced by Melanie Klein, Róheim offered an account of basic human activities, emphasizing the significance of fantasies of destruction and reparation. Marked by a deep cultural pessimism, Róheim always pointed to the cultural superiority of "primitive" people while viewing Western societies as dominated by anal retentiveness and reaction formations.

ÉVA BRABANT-GERÖ

*See also:* Anthropology and psychoanalysis; Ethnopsychanalysis; Hungarian School; Hungary; Magical thinking; Myth; Oedipus complex; Primitive horde; Second World War: The effects on the development of psychoanalysis; Sociology and psychoanalysis/sociopsychanalysis.

### **Bibliography**

- Róheim, Géza (1919). *Spiegelzauber*. Wien: Internationaler Psychoanalytischer Verlag.
- . (1932). Psychoanalysis of primitive cultural types. *International Journal of Psycho-Analysis*, 13: 2–224.
- . (1934). *The riddle of the sphinx*. London: Hogarth Press
- . (1943). *The origin and function of culture*. New York: Nervous and mental disease monographs 3.
- . (1955). *Magic and schizophrenia*. New York: International Universities Press.
- . (1992). *Fire in the dragon and other psychoanalytic essays on folklore* (Alan Dundes, Ed.). Princeton, NJ: Princeton University Press.

---

## **ROLLAND, ROMAIN EDMÉ PAUL-ÉMILE (1866–1944)**

The French author Romain Edmé Paul Émile Rolland was born on January 26, 1866, in Clamecy, a small town in Burgundy, and died on December 30, 1944, in the old village of Vézelay.

Freud held Rolland in high esteem for his insight into the mind of a child, and he called *The Enchanted Soul* “a most beautiful novel.” André Malraux thought Rolland was “the last of the great French romantic novelists.” Quite unlike Freud, Rolland was musical to the core and the seven volumes of his *Beethoven the Creator* were published between 1928 and 1943. He was awarded the 1915 Nobel Prize for literature for his novel *Jean-Christophe*.

A politically engaged intellectual from the time of the Dreyfus Affair at the turn of the twentieth century, Rolland aroused Freud’s admiration for the anti-war stance he took in 1914 with his essay “Au-dessus de la mêlée” (Above the Battle), in which he argued for international brotherhood instead of mutual destruction. Rolland denounced Hitler as early as 1933 and condemned Jewish persecution as a “crime against humanity.” Indeed, Rolland declined the Goethe Prize after the Nazis came to power. After lending critical support to the Soviet Union as a part of anti-Hiterlian strategy, Rolland’s idealism moved him for a time in the direction of non-critical communist fellow-traveler. Rolland’s correspondence shows his introspective side and his value as an eyewitness to history. (Duchatelet, 1976).

Aware of trends in German culture, Rolland read Freud as early as 1909. The two men would exchange about twenty letters from 1923 to 1936; Freud’s first communication was written the same week he was diagnosed with cancer of the jaw. Rolland visited Freud only once, on May 14, 1924.

The highly idealized intellectual and emotional relationship between Freud and Rolland suggests a veritable epistolary transference that served Freud as a sounding board for self-analysis during his later years, and several of his major works found their point of departure in exchanges with his “venerated” alter ego.

Despite differences of background and culture, powerful affinities joined these two romantic heroes. Freud admired the poet and “apostle of love for mankind” (Freud, 1960), while Rolland viewed Freud as a “conquistador” of the new world of the mind. In Spinoza they shared a common thread of influence—Rolland, the Christian without a church, inspired by “the enlightened Spinoza” and Freud the “Jewish heretic.” Both were critical of the dogmas of organized religion but differed over the role of religious feeling. Rolland reproached Freud for not having analyzed the

“oceanic feeling” associated with religiosity. Rolland’s pantheism led him to view mysticism, by contrast, as a path to knowledge of the human mind; this represents an element of Spinoza’s intellectual heritage and contrasts with the uncompromising nineteenth-century atheism of David Friedrich Strauss and Ludwig Feuerbach, to which Freud was heir.

In the first chapter of *Civilization and Its Discontents* Freud located the “oceanic feeling” in the primitive, undifferentiated ego; he pursued the dialogue with Rolland by searching for the causes of civilized unhappiness, which he attributed to excessive repression of sexual and aggressive drives and to the loss of collective ideals. Close to Rolland in his critique of Nazi anti-Semitism, Freud differed with him in showing that quasi-religious idealization of communist dogma masked its underlying violence.

*The Journey Within* (1942), a kind of self-analysis, which Rolland began after his visit to Freud, reveals an unconscious communication with him: he wrote about mourning his two-year-old sister, Madeleine, who died when he was five. In a mirror transference, with twelve years in age between them, Freud analyzed his own childhood grief, associated with the death of his infant brother Julius, when he was about two years old, in his “A Disturbance of Memory on the Acropolis” (1936a), addressed to Rolland on the occasion of the latter’s seventieth birthday. Capping their correspondence and transference relationship, several of Freud’s last writings developed themes first sketched in this final burst of self-analysis.

HENRI VERMOREL AND MADELEINE VERMOREL

*See also:* Certainty; *Civilization and its Discontents*; *Disturbance of Memory on the Acropolis, A*; *Future of an Illusion, The*; *Jouissance* (Lacan); *Judaism and psychoanalysis*; *Mysticism*; *Oceanic feeling*; *Symbiosis/symbiotic relation*.

### **Bibliography**

- Duchatelet, B. (1976). Á propos d’une correspondance qui n’est pas encore générale. *Revue d’histoire littéraire de la France*, 76, 958–975.
- Freud, Sigmund. (1927c). Future of an illusion. *SE*, 21.
- . (1930a). Civilization and its discontents. *SE*, 21.
- . (1960). *Letters*. New York: Basic.

Rolland, Romain. (1959). *The journey within*. New York: Philosophical Library.

Vermorel, Henri, and Vermorel, Madeleine (Eds.). (1993) *Sigmund Freud et Romain Rolland: Correspondance 1923–1936*. Paris: Presses Universitaires de France.

## ROMANIA

On returning from training courses in France and Germany, Gheorghe Preda (1879–1965), a medical officer in the Romanian army, published his considerations on psychoanalysis in a Romanian journal of medical sciences in 1912. Without any personal experience of psychoanalysis, he encouraged the interest of his collaborators, who were the first to propagate Freud's work. Later, in 1923, one of Jean Martin Charcot's students, Gheorghe Marinescu, contributed to making psychoanalysis known to Romanian intellectuals by publishing two articles: an introduction to the study of psychoanalysis and a critique of Freudian theory. Several psychologists and psychiatrists then took an interest in psychoanalysis. One of them, Ion Popescu-Sibiu, entered into correspondence with Freud and became the author of a very complete book on the theory and practice of psychoanalysis: *Conceptia Psihanalitica* (1947). In 1932 he won a Romanian Academy prize for this book. It was in fact a revision of the thesis he presented in 1927, with an addendum of "medico-psychological vocabulary." It was first published in three thousand copies. Around this time more than ten books and theses were published dealing with the applications of psychoanalysis to psychotherapy, forensic medicine, literature, the study of dreams, spiritualism, and career guidance. In a setback, in 1932 an application of psychoanalysis to the work of the Romanian national poet Mihai Eminescu (1850–1889) was considered iconoclastic. In 1934, and again in 1935, attempts to start a journal of psychoanalysis resulted in the appearance of one issue and no follow-up.

Over the next few decades the development of psychoanalysis was limited by the economic crisis of 1929, the rise of the fascist Iron Guard party, which aligned Romania with Nazi Germany, and the communist takeover of the country. In 1946, just after the Second World War, Ion Popescu-Sibiu and Constantin Vlad (1892–1971) founded the Romanian Society for Psychopathology and Psychotherapy. They rallied

around them all those who had been interested in analysis before the war. But psychoanalysis was prohibited in 1948, as it was in all communist countries. Not until 1973 and the new directions opened up by the political head of state Nicolae Ceausescu did a clinical psychological circle organize regular meetings of practitioners. This breach in the wall was short lived, however, and in 1977 it was forbidden to teach psychology. People nevertheless continued to study psychoanalytic texts. The first volume of a translation of Freud's *Introductory Lectures on Psychoanalysis* (1916–1917a [1915–1917]) was published in 1980. But the almost total absence of personal and training analysis was detrimental to any real development of psychoanalysis.

Not until after the fall of the Ceausescu regime could a group of psychotherapists, largely nonphysicians, found the Romanian Psychoanalytic Society in 1990. This society publishes an internal bulletin and a journal that appear on a regular basis. The desire of Romanian analysts to improve themselves professionally is manifest in the numbers that have gone abroad for training and by the 1995 Conference for Eastern Europeans at Constanza, organized with the help of the European Federation for Psychoanalysis.

MICHEL VINCENT

### Bibliography

Diatkine, Gilbert, Gibeault, Alain, Gibeault, Monique, and Vincent, Michel. (1993). La psychanalyse en Europe orientale. In Gilbert Diatkine, Gérard Le Goues, and Ilana Reiss-Schimmel (Eds.), *La psychanalyse et l'Europe de 1993*. Paris: Presses Universitaires de France.

## RORSCHACH, HERMANN (1884–1922)

Swiss psychoanalyst and creator of the projective test that bears his name, Hermann Rorschach was born in Zurich on November 8, 1884. He died in Herisau on April 3, 1922, probably from acute appendicitis, at the age of thirty-seven, nine months after publishing his seminal work, *Psychodiagnostik*.

From childhood Rorschach evinced considerable artistic skill and while in secondary school he hesitated between fine art, natural science, and medicine, opting finally for the latter. In Zurich, where Rorschach principally studied, Eugen Bleuler had created a revolution in

hospital psychiatry by introducing Freud's theories, while his colleague, Carl Gustav Jung, had worked out a word association test on psychodynamic principles. Rorschach obtained his medical license in 1909 and his medical degree in 1912, from the University of Zurich.

From 1909 to 1913, Rorschach worked as an assistant in the psychiatric hospital in Münsterlingen, and there prepared his doctoral thesis, "On Reflex-Hallucinations and Kindred Manifestations." At the same time, he conducted some early experiments on children and adults in which he compared verbal associations with associations aroused by blots of ink, but did not elaborate on this work at the time. Rorschach developed an interest in psychoanalysis about 1911, the date of his first publication. He contributed short articles, reports, and book reviews to the *Zentralblatt für Psychoanalyse* from 1912 to 1914.

After visiting Russia in 1913, Rorschach returned to Switzerland to assume a position as assistant in Waldau, a psychiatric clinic near Bern; his main interest during this period were several unusual Swiss religious sects. In 1915 he was appointed associate director of the asylum at the small town of Herisau, where he would remain until his death.

While at Herisau, Rorschach rekindled his earlier interest in the use of inkblots in psychiatric diagnosis. Over the course of three years, beginning in 1918, he developed a series of cards through experiments with patients to develop a projective test that could indicate the presence of certain personality traits and characteristics. The Rorschach test is an example of a scientific advance due as much to artistic talent as to intellectual rigor.

Published in 1921, *Psychodiagnostics* was not yet a definitive text when Rorschach died the following year. The test won acceptance over time, and by the 1930s it had garnered considerable attention in the United States. The Rorschach Institute was founded in New York in 1939, and Henri Ellenberger, with his biographical essay in 1954, restored Rorschach's stature and significance. In the United States, although the test was widely criticized from the 1950s and remains a controversial assessment tool, a revision by John Exner in the 1970s brought the Rorschach renewed and continuing attention.

In 1919, when the Swiss Society of Psychoanalysis was founded by Oskar Pfister and Emil and Mira Oberholzer, Rorschach was one of its eight members, and served as vice-president. He practiced psychoanalysis with a small number of patients. Training analyses

were not then required, and Rorschach himself was never analyzed. A selection of Rorschach's articles was published in Germany in 1965.

MIREILLE CIFALI

*See also:* Psychological tests; Psychology and psychoanalysis; Switzerland (German-speaking).

### **Bibliography**

Ellenberger, Henri. (1954). Hermann Rorschach, M.D., 1884–1922: A biographical study. *Bulletin of the Menninger Clinic*, 18 (5), 173–219.

Exner, John E., Jr. (1974). *The Rorschach: A comprehensive system*. New York: John Wiley.

Rorschach, Hermann. (1942). *Psychodiagnostics: A diagnostic test based on perception*. New York: Grune & Stratton.

———. *Gesammelte Aufsätze*. (1965). Bern, Germany: H. Huber, 1965.

---

## **ROSENFELD, EVA MARIE (1892–1977)**

The psychoanalyst Eva Rosenfeld was born in Berlin in 1892 and died in Great Britain in 1977.

Her father, Theodor Rosenfeld, an impresario and a member of Berlin's wealthy Jewish bourgeoisie, died in 1907, when she was fifteen, leaving her with a mother who went into mourning until her death in 1942. Shortly after her father's death, she decided to look after the Zellerhaus, an institution for poor young orphan girls. At the age of seventeen she became engaged to her cousin Valentin, a young lawyer who knew Freud, and having married him in 1911, she moved to Vienna to live. She had three children, the first two of whom, both boys, died of dysentery in 1918.

She then created an establishment for adolescent girls in difficulty, which Siegfried Bernfeld recommended to Anna Freud in 1924 when Anna was seeking a home for a patient in difficulty. This was the beginning of a friendship between the two young women that lasted until 1932. In July 1927 the death of her fifteen-year-old daughter, Rosemarie (Mädi), in a mountain accident, again drove her to care for children in order to overcome her heartbreak. With the help of Dorothy Burlingham and under the pedagogical and psychoanalytical authority of Anna Freud, she then founded the Burlingham-Rosenfeld Heitzing School, named after the district where the garden of Eva's house was home to the school.

Encouraged by Anna Freud, she commenced analysis with Freud in March 1929, an analysis that lasted until 1932, of which she later said that the “transference was intense and passionate.” She also exchanged abundant correspondence with Anna while the latter was staying with her father in the clinic at Tegel. Ernst Simmel, who needed help to manage this disorganized clinic, appealed to Rosenfeld in 1931. As bursar, she was in charge of organizing its dissolution.

When Eva moved to Berlin, it marked the end of the school and her intense friendship with Anna Freud, which was further accentuated by her departure for Great Britain in 1936. She met Melanie Klein shortly after her arrival in London and, fired with enthusiasm for her personality and her work, she commenced analysis with her in 1938, an analysis that was to last in fits and starts until 1941, when Klein left for Scotland and Rosenfeld went to Oxford. Their relationship ended with a break: “You have sacrificed your analysis for the friendship of Anna Freud!” Eva and Anna, in fact, remained in contact until the very end.

There are few details concerning the rest of Rosenfeld’s long life, and her career as an analyst. Throughout her life she remained in contact with Anna Freud, although it was obvious that as soon as she left Vienna her place with Anna was taken by Dorothy Burlingham.

ALAIN DE MIJOLLA

*See also:* Blos, Peter; Burlingham-Tiffany, Dorothy; Erikson, Erik Homburger; Freud, Anna; Guilbert, Yvette; Hietzing Schule/Burlingham-Rosenfeld School; Tegel (Schloss Tegel).

### **Bibliography**

Heller, Peter. (1990). *A child analysis with Anna Freud*. Madison, CT: International Universities Press.

———. (1992). *Anna Freud’s letters to Eva Rosenfeld*. Madison, CT: International Universities Press.

---

## **ROSENFELD, HERBERT ALEXANDER (1910–1986)**

Psychoanalyst Herbert Alexander Rosenfeld was born in Nuremberg, Germany, on July 2, 1910, and died in London on October 27, 1986.

Rosenfeld came from a middle-class Jewish family. He studied medicine at several German universities and became interested in psychiatry while at Munich University, from which he graduated in 1934. In 1935, due to the anti-Jewish racial laws, Rosenfeld emigrated to England, where he worked in several hospitals after having taken all his medical examinations again in Glasgow. During this period he became interested in the possibility of treating severely psychotic patients using psychotherapy instead of drugs. In 1942 he began his training analysis with Melanie Klein at the British Psycho-Analytical Society in London. He qualified as an associate member in 1945, became a full member in 1948 and a training analyst in 1949. In 1972 he became a F. R. C. Psych, fellow of the Royal College of Psychology.

For decades until his death, Rosenfeld practiced in London and taught at the Institute of Psycho-Analysis as well as abroad, being particularly interested in the psychoanalytic treatment of psychotic and severely disturbed patients. Together with Wilfred Bion and Hanna Segal, he widened the teaching of Melanie Klein and became a world-wide acknowledged authority in his field. In 1947, using the clinical material from his first training case, he published his first psychoanalytical contribution, “Analysis of a Schizophrenic State of Depersonalisation.” The case became one of the landmarks in the history of the psychoanalytical treatment of psychosis, because it was the first case of an adult psychotic patient being successfully treated by a purely interpretative psychoanalytic method. In this paper Rosenfeld used Klein’s seminal concept of projective identification, which he widened and clarified in successive papers.

Another important observation already present in his first paper was that of transference psychosis, which Rosenfeld differentiated from that of transference neuroses in order to describe the massive projection of unconscious fantasies of the psychotic patient on the analyst and the primitive nature of his object relations.

Another important paper related to the problems faced in treating psychotic patients was Rosenfeld’s research into what he called “confusional states” (1949). Although mainly related to processes characteristic of chronic schizophrenia, Rosenfeld’s observations help to better understand the problem of the impossibility or difficulty in normal splitting between bad and good aspects of the self and of the external

and internal objects which massively characterize chronic schizophrenia but to a certain degree can be found even in less disturbed patients. He collected his first set of papers in 1965 in a book *Psychotic States*, which soon became a classic. Later, Rosenfeld became increasingly interested in the study and treatment of narcissistic disturbances and personalities. Particularly important is his paper “A Clinical Approach to the Psychoanalytic Theory of the Life and Death Instincts: An Investigation into the Aggressive Aspects of Narcissism,” published in 1971, where he stressed the link between narcissism and the death drive.

During the last years of his life Rosenfeld became interested in problems related to the difficulties in communication and the impasse in the psychoanalytic treatment of severely and less severely disturbed patients, and on the role played by the analyst in creating those impasses. (See *Impasse and Interpretation*, published in 1986.)

RICCARDO STEINER

*See also:* Alcoholism; Envy; Infantile psychosis; Narcissism; Projective identification; Paranoid position; Paranoid-schizoid position; Psychotic transference; Schizophrenia.

### **Bibliography**

- Green, André. (1976). Un, autre, neutre: Valeurs narcissiques du même. In *Narcissisme de vie, narcissisme de mort* (pp 31–79). Paris: Minuit.
- Kernberg, Otto F. (1989). Impasse and interpretation by Herbert Rosenfeld. *International Journal of Psycho-Analysis*, 70, 173–177.
- Segal, Hanna, and Steiner, Riccardo. (1987). H. A. Rosenfeld. *International Journal of Psycho-Analysis*, 68, 415–419.
- Steiner, John. (1993). *Psychic retreats*. London and New York: Routledge.
- Steiner, Riccardo. (1989). On narcissism: The Kleinian approach. In Otto F. Kernberg (Ed.), *Narcissistic Personality Disorder*, vol. 12 (pp. 741–770). Psychiatric Clinics of North America.

## **ROSENTHAL, TATIANA (1885–1921)**

Tatiana Rosenthal, a Russian psychoanalyst, physician, and specialist in neurology, was born in Saint Petersburg in 1885 and committed suicide there in 1921.

Coming from a Jewish family, she emerged from childhood with an uneasy disposition coupled with a passionate temperament. During the Russian revolution of 1905, she embraced the cause of the workers' movement. In 1906 she settled in Zurich, where she studied medicine. When she read *The Interpretation of Dreams* (Freud, 1900a), she was inspired with the idea of combining the ideas of Freud and Marx.

After she finished her studies, she moved to Vienna. She became a member of the Vienna Psychoanalytic Society in 1911, and the following year she began to attend the Wednesday meetings. After the outbreak of World War I, she returned to Saint Petersburg and the Psychoneurological Institute there, devoting considerable energy to interesting Vladimir Bechterev, head of the institute, in psychoanalysis. Fighting to have psychoanalysis used in the education of children, she was a precursor of Vera Schmidt at the Moscow Detskiy dom (Children's Home). In 1919 she became director of the polyclinic for the treatment of psychoneuroses attached to Psychoneurological Institute. In 1920 she was appointed director of the clinic for neuropathic children.

One year later Rosenthal, mother of a young child, committed suicide. Her death at her own hand becomes less enigmatic when placed in its historical context: Bolshevism, having repressed the workers' strikes in Saint Petersburg and crushed the Cronstadt uprising, was beginning to show its terrorist face. Her suicide, at the age of thirty-six, may have been the reaction of a personality whose idealism was strained to breaking point.

Rosenthal's only published work is the essay “Stradanie i tvortchestvo v Dostoievskoni” (Suffering and creation in Dostoyevski), published in Russian in 1920 in the journal *Voprosi psichologiiu litschnosti*. The second part of this essay and two other articles, on war neuroses and Alfred Adler's individual psychology, have never been published. In her Dostoyevski essay, Rosenthal dealt with the psychology of the artist and unconscious influences in the genesis of artistic work. To do so, she had to clarify what psychoanalysis can contribute to understanding works of art. For Rosenthal, certain insufficiently sublimated pathological components of the artist's psychology detract from artistic works. Dostoyevsky's three youthful novels are a case in point.

ANNA MARIA ACCERBONI

See also: Germany; Russia/USSR.

### **Bibliography**

Accerboni-Pavanello, Anna Maria. (1992). Tatiana Rosenthal: Une brève saison analytique. *Revue internationale d'histoire de la psychanalyse*, 5, 95–109.

Neidisch, S. (1921). Dr Tatiana Rosenthal, Petersburg. *Internationale Zeitschrift für Psychoanalyse*, 7, 384–385.

Rosenthal, Tatiana. (1920). Stradanje i tvortchestvo v Dostoievskoni. *Voprosy psihologiju litschnosti*.

---

## **ROSS, HELEN (1890–1978)**

Helen Ross, a psychoanalyst and administrator, was born March 16, 1890, in Independence, Missouri, and died August 10, 1978, in Washington, D.C.

One of seven children, Helen Ross was born into a family that highly valued education. Her older brother supported her college education, and after her own graduation from the University of Missouri in 1911, she worked for five years as a school teacher to enable her younger siblings to continue their education. During this period she augmented her income by teaching English to immigrants in a Jewish settlement night school in Kansas City. In 1916 she began graduate work in sociology and economics at Bryn Mawr. Ross gave up her graduate studies, however, at the urging of Pauline Goldmark, one of the famous Goldmark sisters, whose sister Alice was married to Supreme Court Justice Louis Brandeis, to accept a job as a field agent for the U.S. Railroad Administration, whose women's division was headed by Pauline Goldmark. For two years she traveled all over the United States, investigating the working conditions of women working on the railroads and, she emphasized in a memoir, making sure they were getting equal pay for equal work.

In 1914 she and an older sister established a summer camp for girls in Michigan, which they ran together for the next thirty-four years. Ross later wrote that the constant contact with “the everyday problems of normal children” sharpened her interest in human development and made her eager to deepen her understanding of personality development. This led her to an interest in psychoanalysis, and in 1929, at the urging of Franz Alexander who had recently arrived in Chicago, she went to Vienna. There she was analyzed by Helene Deutsch and began a lifelong friendship and

collaboration with Anna Freud. In particular, Ross was instrumental in the establishment of the Hampstead Clinic through her efforts to secure ongoing financial support for the clinic from the Marshall Field Foundation in Chicago. She also assisted in the translation of August Aichhorn's *Wayward Youth*.

After returning to Chicago in 1934, she began a private practice and acted as a consultant to a number of social agencies. She also wrote a newspaper column, *About Our Children*, for the *Chicago Sun-Times*. Ross used her influence as a consultant to social welfare agencies and her newspaper column to convey in clear and intelligent language the insights of psychoanalysis to teachers, social workers, and parents. In 1942 she began a fourteen-year tenure as the administrative director of the Chicago Psychoanalytic Institute. In 1956, at the request of the American Psychoanalytic Association, she and Bertram D. Lewin undertook an extensive survey of the training programs of seventeen American psychoanalytic institutes. The resulting book, *Psychoanalytic Education in the United States* (1960), reviewed, among other topics, the history of psychoanalytic education, presented a detailed analysis of candidates in training and how they were selected, analyzed curriculums for both adult and child analysis programs, and discussed the role of the teaching and supervising analyst in psychoanalytic training. The thoroughness of their survey, combined with its dispassionate tone, created a climate that allowed many institutes to closely examine and make changes in their educational programs. This was a considerable achievement and the success of the survey probably owes something as well to the deep respect and affection that their colleagues felt for Ross and Lewin.

After completing this project Ross moved to Washington, D.C., and became a faculty member and supervising child analyst of the Washington Psychoanalytic Institute, and also served as a psychoanalytic consultant, teacher, and supervisor at other institutes. Helen Ross's contributions to psychoanalysis as a supervisor, writer, consultant, and administrator were considerable. Anna Freud, in a touching letter to one of Ross's sisters after her death, described her own sense of deep loss by gracefully noting the personal qualities that made Ross such a formidable and beloved figure. “For me it means that something inexpressibly precious has gone and will never come again. Helen's rare combination of goodness and cleverness, firmness and gentleness, tolerance and sharpness of

judgment, friendship and undemandingness was hers alone. I hope she knew how much not only I, but many other people felt about her.” These personal qualities were accompanied by an indomitable intellectual curiosity and a determination that took her from the Midwest of Missouri and Kansas east to Bryn Mawr and finally to Europe and Vienna, where she found her vocation in one of the most vibrant intellectual movements of the twentieth century.

NELLIE L. THOMPSON

### **Bibliography**

- Hunter, Doris. (1979). Helen Ross 1890–1978. *The Psychoanalytic Quarterly*, 48, 465–469.
- Ross, Helen. (1951). *Fears of children*. Chicago: Science Research Associates.
- Ross, Helen, and Lewin, Bertram D. (1960). *Psychoanalytic education in the United States*. New York: W. W. Norton.
- Thompson, Nellie. (2001). American women psychoanalysts 1911–1941. *Annual of Psychoanalysis*, 29, 161–177.

## **RUBINSTEIN, BENJAMIN B. (1905–1989)**

American physician Benjamin B. Rubinstein was born on December 3, 1905, in Helsinki and died on December 7, 1989, in New York City. He grew up in a warm, moderately affluent family of Finnish Jews. After attending a gymnasium in Copenhagen, he graduated from the University of Helsinki Medical School in 1936. He worked as an undergraduate research assistant to the neurophysiologist Ragnar Granit, gaining a lasting appreciation of scientific research and neurophysiology. His residency in psychiatry and neurology, begun in London, was interrupted by military service in the Finno-Russian wars, and completed at the University Hospital, Helsinki, in 1947.

In 1940 he married Dinorah Rosenthal (who later became a well-known photographer). David Rapaport recruited him as a psychiatric research fellow at the Menninger Foundation (Topeka, Kansas) in 1947. From 1948 to 1953, he was a staff psychiatrist and received psychoanalytic training. On graduating he moved to New York, where he remained in private practice until his death. He and his wife became American citizens in 1957; they had no children.

Rubinstein had strong interest and talents in music, poetry, and the theater, having been an actor and composer, principally of songs. He held teaching positions at the Albert Einstein College of Medicine and at Bronx Municipal Hospital Center, and served as a consultant to the Research Center for Mental Health, NYU. For several years, with Hartvig Dahl, he led a research seminar on clinical inference at the New York Psychoanalytic Society.

Because of the traumatic reception of his first psychoanalytic paper in 1952 (on the psychoanalytic concept of sexuality), he was slow to attempt other publication. He began with a paper on “Psychoanalytic Theory and the Mind-Body Problem” (chapter 1 of the *Collected Papers of Benjamin B. Rubinstein*; 1997). His final published work was “The Experience of Tragedy, Expectations, and the Moral Order” (chapter 17). All but a few discussions of papers were collected in a posthumous volume, plus several previously unpublished manuscripts.

Rubinstein had no peer among working clinical psychoanalysts in his expert grasp of the philosophy of science and his ability to apply it to psychoanalysis. His contributions to the juncture of these disciplines were warmly appreciated by such outstanding philosophers of science as Adolf Grunbaum (University of Pittsburgh) and Robert Cohen (Boston University). He contributed to the training and inspired the work of philosophers (Robert Shope), psychoanalysts (Hartvig Dahl, Emanuel Peterfreund), and psychologists (Morris N. Eagle, Robert R. Holt) alike, though his works and via informal seminars on psychoanalytic theory. His unpublished first paper anticipated many of the most cogent criticisms of Freud’s metapsychology that have appeared in the past four decades. His clarification of the clinical theory, its basic assumptions, and its hierarchical organization makes it more easily convertible into a workable, cumulative, and testable scientific theory. Rubinstein was first to demonstrate the probabilistic nature of the theory’s propositions, with profound implications for its verification—for example, Karl Popper’s model of testability is shown to be inapplicable. It is difficult to predict the eventual impact of his work, but if psychoanalysis makes major progress toward becoming a true science it will have been made possible as much by his work as by that of anyone else.

ROBERT R. HOLT



See also: Psychoanalytic epistemology; Science and psychoanalysis.

### **Bibliography**

Rubinstein, Benjamin B. (1997). Psychoanalysis and the philosophy of science. In Robert R. Holt (Ed.), *Collected papers of Benjamin B. Rubinstein, M.D.* Madison, CT: International Universities Press.

---

## **RUSSIA/USSR**

Psychoanalysis was introduced into Russia in 1905 when Nikolai Osipov (1877–1934) returned to Moscow after training with Carl G. Jung, about the same time as Moshe Wulff (1878–1971) settled in Odessa after studying with Karl Abraham. Like their teachers, neither man underwent a personal analysis. Osipov and psychiatrist Osip Feltzman carried out the first psychoanalytically-based treatments and taught Freudian theory at a university clinic directed by Vladimir Serbski who, although critical of the significance accorded sexuality in psychoanalysis, recognized therapeutic successes of the approach.

Near the beginning of the First World War, Sigmund Freud (1914d) wrote: “In Russia, psychoanalysis has become generally known and has spread widely; almost all my writings, as well as those of other adherents of analysis, have been translated into Russian. But a really penetrating comprehension of analytic theories has not yet been evinced in Russia; so that the contributions of Russian physicians are at present not very notable. The only trained analyst there is M. Wulff who practices in Odessa” (p. 33). That Wulff was considered an exception is explained by the quality of his publications in German; he was also the chief translator of Freud’s works into Russian.

Among the early Russian analysts, Wulff and Sabina Spielrein (1882–1941) produced the most innovative clinical and theoretical work, but they wrote in German. Spielrein’s important paper, “Destruction as the Cause of Becoming,” influenced Freud’s development of the theory of the death instinct. Articles by Osipov and Alexander Luria (1902–1977) discussed applied psychoanalysis while revealing their authors’ lack of training and clinical experience.

The advent of the communist regime after the 1917 revolution upset the development of psychoanalysis,

both ideologically and institutionally. The Communist Party, with Nietzschean aspirations to create the “new man,” at first lent its indispensable imprimatur to the creation of the Russian Psychoanalytic Society in 1922, presided over by Serbski’s successor at the State Psychoanalytic Institute, Ivan Ermakov. These organizations shared offices in a beautifully appointed Art Nouveau mansion in Moscow.

Following in the footsteps of Tatiana Rosenthal, who in 1911 had introduced psychoanalysis to St. Petersburg, Vera Schmidt (1889–1937), a physician and pedagogue, opened a psychoanalytic “children’s home” (*Detski Dom*) in 1921. In 1922 her husband, Otto J. Schmidt (1891–1956), although a mathematician, began to supervise the Psychological and Psychoanalytic Library, an imprint of the State Publishing House; he made possible the publication in Russian of Freud’s works.

In spite of such developments, conflicts inside the Soviet Union proved lethal for analysis both as a profession and a psychological theory even as it gained international recognition. Although at the Berlin Congress in 1922 Freud seemed pleased with progress, Ernest Jones was more cautious, especially as regards the Moscow group; he supported a group based in Kazan and headed by Luria. The International Psychoanalytical Association (IPA) requested that the Russian Society have at least two “instructors”; Spielrein thus returned to Moscow from Switzerland, joining Wulff, who had been in the city since 1919. The Kazan group relocated to Moscow and the IPA recognized the Russian Society at the Salzburg Congress in 1924.

But all was not well from the start. Osipov had already fled communism to settle in Prague, and after just eighteen months in Moscow, Spielrein retired to her birthplace, Rostov-on-Don, where she and her family met a tragic end at the hands of the Nazis during World War II. In 1927, Luria turned to neuropsychology and Wulff fled to Berlin.

By the end of the 1920s, when physicians were compelled to solemnly renounce private practice, training analyses were no longer available in the Soviet Union. The Russian Psychoanalytic Society, which formally existed until 1933, was vitally dependant upon the whims of various “red professors” who were controlled by the Communist Party; this would have made training with Wulff or Spielrein impossible in any event. This situation went unappreciated by Wilhelm Reich

when he visited Russia in 1929 under the auspices of the IPA. Reich paid no attention to Wulff and Spielrein; he was instead duped by the communist professors to such an extent that he reported that analysts occupied important posts in the Soviet Union.

Psychoanalysis required the approbation of the Communist Party, and initially received it most especially from the revolutionary leader Leon Trotsky. The fortunes of analysts in the Soviet Union declined upon Trotsky's fall from grace and political exile to Alma-Ata (now Almaty, Kazakhstan) in 1928, shortly before the Psychoanalytic Institute closed its doors and the Psychoanalytic Society became inoperative. In 1930, a year after Trotsky was exiled from the Soviet Union altogether, all psychoanalytic publications stopped. Otto Schmidt had not awaited the inevitable; he retrained to become a noted Arctic scientist and explorer.

In *Civilization and Its Discontents* (1930a [1929]) Freud commented, apropos Russian communism: "One only wonders, with concern, what the Soviets will do once they have wiped out their bourgeois" (p. 115). In 1931, the great proletarian writer Maxim Gorky (1868–1936) settled into Ryabushinsky Mansion, where Stalin met with him and famously called writers "engineers of human souls." Freud's works were consigned to "special storage" in public libraries; they might be consulted, but propagation of Freudian ideas was in this way greatly limited.

The Cold War saw development of a powerfully anti-psychoanalytic establishment in the Soviet Union. In 1950, at the Pavlov Conference, sponsored by the Soviet Academy of Sciences and the Academy of Medical Sciences, psychoanalytic concepts were criticized in a welter of attacks, with many participants obliged to repent for having previously voiced positive comments about analysis.

The official anti-psychoanalytic stance was modified somewhat three decades later when, at the end of East-West detente, participants at the Tbilisi Congress, held in Georgia in 1979, promoted a theory of "unconscious behavior" proposed by the Georgian experimental psychologist Dmitri Uznadze (1887–1950). The congress was preceded by publication of three long volumes on "the unconscious" that included a significant number of articles by Western authors such as André Green and Daniel Widlocher; these texts, however, were not translated into Russian. For fear of ideological manipulation and compro-

mise, well-known psychoanalysts from the IPA did not attend, although Leon Chertok and others, and especially Lacanians such as Serge Leclaire, accepted the invitation in the hope of starting a dialogue that was expected to be difficult in any event due to linguistic and political barriers. The Western articles were not included in the fourth volume, which appeared in 1985, concerning "Results of the Discussion." Some present-day Russian analysts consider the Tbilisi Congress the first step in the renewal of Russian psychoanalysis.

During *perestroika*, from 1985 to 1991, Russians were allowed to organize psychoanalytic meetings. In 1987, a first encounter with French analysts from the Institute of the Freudian Field took place in Moscow, followed by meetings with representatives of the School of the Freudian Cause. In 1988, a meeting seems also to have taken place with representatives of the American Psychoanalytic Association. Two new academic societies were created, the members of which almost all belonged to the Society of Moscow Psychoanalysts. The Franco-Soviet Group of the Freudian Field, founded in 1988, became the Russian Circle of the European School of Psychoanalysis from 1991 until 1995; its orientation was Lacanian and it was established without official statutes or stable direction. The Soviet Psychoanalytic Society, founded in 1989 and in 1991 renamed the Russian Psychoanalytical Association, did have official statutes and was presided over by Aron Belkin (1927–2003), who had a special interest in the social uses of psychoanalysis. The IPA welcomed Belkin at its congresses in Rome in 1989 and in Buenos Aires in 1991, and gave his group the special status of guest study group.

The historic events of August 1991, during which Russia separated from the Soviet Union (which itself was dissolved several months later), created prospects for travel and genuine psychoanalytic training. Thus, in 1992, Pavel Katchalov was able to undergo a personal analysis and training in Paris, helped by a grant from the French government and an alliance between Hopital Esquirol in Saint-Maurice, a suburb of Paris, and the Serbski Center in Moscow. Alexander Khoshtov, of Lomonosov University, and Victoria Potapova traveled to Paris in 1994. All three joined the Paris Psychoanalytical Institute; others followed suit. When, in 1995, Lola Komarova left to train in London, it was the end of the Russian Psychoanalytical Association. Some former members, decided to create

a new group following an IPA curriculum, the Moscow Society of Psychoanalysts. Several of its members had classical or shuttle analysis; the French influence was dominant. Since 1995, an annual Franco-Russian debate has been held every fall by Katchalov and Hervé Benhamou, a member of the Paris Psychoanalytic Society, with the support of the French Embassy.

The Moscow Psychoanalytic Society was founded due to Boris Kravtsov, who in the 1970s ran a psychoanalytic seminar that was attended by a number of psychologists, including Pavel Snejnevsky, Julia Alyoshina, and Sergei Agrachev. In 1988 he established a psychoanalytic section of the Association of Practicing Psychologists, and by 1990 contacts were established with IPA members in the United States, Germany, the Netherlands, and the Czech Republic, where several members were trained. Alyoshina and Snejnevsky were trained in the United States and decided to remain there. In 1995, this group became the Moscow Psychoanalytic Society, over which Agrachev presided until his death in 1998, promoting a training program for psychoanalysts with IPA support. Publications of this group soon included translations of works by Otto Kernberg, the three volumes of the *Modern Psychoanalysis* by Helmut Thomä and Horst Kächele, and Melanie Klein's *Envy and Gratitude*. The institute's subsequent director, Igor Kadyrov, was the first Russian to be elected a direct member of the IPA; he was trained by shuttle analysis, as were the other members of the society, which by 2004 included six members of the IPA.

In 1998 the St. Petersburg Society of Child Psychoanalysis was founded, the result of productive exchanges between psychoanalysts at the Anna Freud Centre in London and a Russian group that included Svetlana Chaeva and Nima Vasilieva, the society's president at that time.

Problems of quackery and imposture have plagued recent psychoanalysis in Russia. Institutes and societies of dubious origin have sprung up throughout the country, which train ersatz therapists without personal analysis, "certifying" them to take profitable advantage of psychosocial misery. With the decree of June 19, 1996, concerning "the revival and development of philosophic psychoanalysis, clinical and applied," President Boris Yeltsin made possible establishment of the controversial East European Institute of Psychoanalysis in St. Petersburg. The Russian intelligentsia and general public alike have grown more distrustful of

untrained or quack psychoanalysts. As a countermeasure, the two Moscow Institutes have combined forces to provide training and to improve awareness through yearly psychoanalytic seminars.

ALEXANDRE MIKHALEVITCH

### **Bibliography**

- Angelini, Alberto. (1988). *La psicanalisi in Russia: dai Percursori ali anni trenta*. Naples: Liguori Editore.
- Freud, Sigmund. (1914d). On the history of the psychoanalytic movement. *SE*, 14: 1–66.
- . (1930a [1929]). Civilization and its discontents. *SE*, 21: 57–145.
- Katchalov, Pavel. (1994). Historiques des méthodes psychothérapeutiques dans l'ancienne URSS. *Journal de psychiatrie*, 7, 102–104.
- Marti, Jean. (1976). La psychanalyse en Russie et en Union Soviétique. *Critique*, 32, 199–236.
- Miller, Martin. (1998). *Freud and the Bolsheviks: Psychoanalysis in imperial Russia and the Soviet Union*. New Haven, CT: Yale University Press.

---

### **RYCROFT, CHARLES FREDERICK (1914–1998)**

Psychoanalyst and psychiatrist Charles Frederick Rycroft was born on September, 9, 1914, in Basingstoke, England, and died on May, 24, 1998, in London.

Rycroft grew up in Hampshire. His father, Sir Richard, was a country squire and the fifth Baronet in a family that traced its ancestry to before the Norman Conquest. When Charles was eleven his father died, and an elder half-brother succeeded to the title and the estate. Charles was educated at Wellington College, and then Trinity College, Cambridge, from which he graduated with honors in 1936 in economics and history. Charles had briefly been a Communist at Cambridge, where the Bloomsbury analyst Karin Stephen encouraged him to apply for psychoanalytic training. Ernest Jones thought that Charles should become a qualified physician; accordingly he started his psychoanalytic and medical training in 1937. He was analyzed first by Ella Sharpe, and after her death by Sylvia Payne. He finally qualified in medicine in 1945.

For almost three decades Rycroft was the leading intellectual force in independent British psychoanalytic circles. Within the British Psychoanalytic Society he became an associate member in 1949, a full member in 1952, and a training analyst in 1954. He was joint librarian (1952–54) with Masud Khan, served on the editorial board of the *International Journal of Psychoanalysis* (1953–54), and was scientific secretary (1956–59). He began to write reviews and essays for *The Observer* and *The New York Review of Books*, and beginning in 1965 started to withdraw from the British Society. Rycroft was bored and alienated by the long-standing ideological quarrels within the British Society.

Nonetheless he analyzed such notable figures as R. D. Laing, Peter Lomas, and Alan Tyson, in addition to a series of eminent people within British intellectual life. He also became one of the most well-known public expositors on psychoanalytic matters, best known for his *A Critical Dictionary of Psychoanalysis* (1968) and his book *The Innocence of Dreams* (1979). He remained in private practice until a week before he died.

Rycroft's special contribution to psychoanalysis stemmed directly from his being broadly well-educated and cultured. Out of his aristocratic background he succeeded in being a distinctive and original voice. He always stressed the constructive power of imagination, and he tried to steer clear of the reductionism and negativism that characterized so much of the early psychoanalytic thinking. Psychoanalysis belonged, he felt, within the humanities and moral sciences, not the natural sciences. He felt particularly inspired by the examples of Donald Winnicott and Erik Erikson, both of whom he considered kindred spirits. Rycroft took a special interest in the problem of creativity, and wrote on how analysts tended to rely on the "ablation" of their biological pasts, substituting instead their lineage in analytic training. The illusion of having created oneself was, he proposed, a defensive reaction characteristic of analysts, an ahistorical or

anti-historical tendency that could be good individually but was not desirable for the field as a whole. Idealizations of the training analysis and the so-called apostolic succession follow from such use of ablation. Ablation as a concept can help understand why it has unfortunately been so often a case of *lese-majesté* to talk about Freud—who had his own difficulties acknowledging his antecedents—within the regular categories of intellectual history. Rycroft's spiritual daring was in a sense an extension of Freud's own historic independence, even though that common trait had inevitably to lead in different directions.

Rycroft, widely acknowledged for his general brilliance, represented the best tradition of British free-thinking within psychoanalysis. He not only interpreted dreams independently of Freud, but took an individual slant on Freud's whole legacy. Rycroft expressed himself in careful, understated prose that is rewarding for its subtleties.

PAUL ROAZEN

*See also:* Creativity; Dream; Great Britain; Internal/external reality; Reich, Wilhelm.

### **Bibliography**

- Rycroft, Charles (Ed.). (1967). *Psychoanalysis observed*. New York: Coward.
- . (1968). *Anxiety and neurosis*. London: Allen Lane.
- . (1968). *A critical dictionary of psychoanalysis*. London: Nelson.
- . (1968). *Imagination and reality*. London: Hogarth Press.
- . (1971). *Wilhelm Reich*. New York: Viking.
- . (1979). *The Innocence of dreams*. London: Hogarth Press.
- . (1985). *Psychoanalysis and beyond*. London: Chatto.
- . (1991). *Viewpoints*. London: Hogarth.



# S

## 2

### SACHS, HANNS (1881–1947)

The Austrian psychoanalyst and doctor of law Hanns Sachs was born on January 10, 1881 in Vienna and died on January 10, 1947 in Boston.

Sachs was the son of a Jewish lawyer whose family roots were in Bohemia. After studying law at the University of Vienna, he earned his doctorate in 1904 and began to practice as a lawyer.

The same year was marked by the determining experience of his life, his reading of Sigmund Freud's *The Interpretation of Dreams* (1900), which made a very strong impression on him. He made contact with Freud and, in 1909, was admitted to the Wednesday society. He then participated in the "Committee," the limited circle of the first psychoanalysts around Freud.

Sachs had artistic and literary gifts. He translated Rudyard Kipling's poems into German, and had a sustained interest in the possibilities of applying the views and methods of psychoanalysis to cultural phenomena. Together with Otto Rank, with whom he was closely linked until Rank's break with Freudian psychoanalysis, he published *The Significance of Psychoanalysis for the Mental Sciences* (1913), and co-directed the journal *Imago*, created the previous year, whose title Sachs himself had chosen with reference to Carl Spitteler's 1906 novel.

In 1918 Sachs abandoned his legal practice to become a professional analyst in Zürich. In 1920 he became a training analyst at the Berliner Psychoanalytisches Institut (BPI; Berlin Psychoanalytic Institute) headed by Karl Abraham. The analysts who trained with him included, notably, Franz Alexander, Michael Balint, Erich Fromm, Rudolf Löwenstein, and Karen

Horney. In 1932, anticipating the full magnitude of political developments, he left Germany and emigrated to the United States. He taught at the Harvard Medical School in Boston, where he was one of the few analysts without a degree in medicine. Despite his authority as a training analyst in the Boston Psychoanalytic Society (BoPS), and despite the esteem in which he was held as someone close to Freud, his role was not universally accepted, mainly because of the issue of lay analysis. In 1939, following in the footsteps of the Austrian journal, he founded *American Imago*, which is still published today. He died on January 10, 1947, on his sixty-sixth birthday, in Boston.

Sachs always showed himself to be a loyal disciple of Freud. His *Freud: Master and Friend* (1944) presents a portrait of Freud that is dominated by loyalty, respect, and sympathy. In his presentations on clinical analysis, dealing with various themes, he always remained within the framework of Freudian theory. In works intended for the general public, such as *Zur Menschenkenntnis: Ein psypsychoanalytischer Wegweiser für den Umgang mit sich selbst und anderen* (Contribution to the knowledge of man: psychoanalytic guide to relations with oneself and others, 1936), he attempted to popularize psychoanalysis. He and Abraham advised Georg Wilhelm Pabst on *Mysteries of a Soul* (1926), a cinematic translation of Freud's world and ideas. Sachs took an interest in all realms—political, social, cultural, and, in particular, literary—whose understanding he believed could be enhanced by psychoanalysis. He wrote essays on Otto von Bismarck, the psychoanalysis of films, and kitsch. In 1930 he published a historical psychoanalysis of the Roman emperor Caligula, entitled *Bubi Caligula* (Little Caligula). He was also interested in Shakespeare, Schiller, and Baudelaire, among others.

In *Gemeinsame Tagträume* (Collective daydreams), published in 1924, Sachs developed a remarkable theory of literary creation that even today remains under-appreciated. Its argument is as follows: The determining factor is not talent or the individual effort of the artist, but rather the social character of the work. Sachs saw literary production first and foremost as a social performance: Literature, he argued, creates a social bond in the form of a recognized discourse, in which the unconscious and the repressed, which cannot express themselves otherwise, come into language. The condition for this is the literary form of the work of art, which he interpreted as a social compromise in which repressed instinctual needs are worked through. This theory of the work of art as a collective daydream was further reworked in his later works. His last book, *Masks of Love and Life*, published posthumously in 1948, broadens these conceptions by considering philosophical problems in the light of psychoanalysis.

REINER WILD

See also: American Imago; Applied psychoanalysis and the interaction of; Berliner Psychoanalytisches Institut; Cinema criticism; Cinema and psychoanalysis; Germany, history of psychoanalysis in; *Imago. Zeitschrift für die Anwendung der Psychoanalyse*; Imago Publishing Company; *Secrets of a Soul*; Visual arts and psychoanalysis; Secret Committee; Société psychanalytique de Paris and Institut de psychanalyse; Training analysis; Wiener psychoanalytische Vereinigung; World War I.

### Bibliography

- Moellenhoff, Fritz. (1966). Hanns Sachs, 1881–1947: the creative unconscious. In *Psychoanalytic pioneers*. (F. Alexander, S. Eisenstein, and M. Grotjahn, Eds.) New York and London: Basic Books.
- Sachs, Hanns. (1924). *Gemeinsame tagträume*. Berlin, Leipzig, and Vienna: Internationaler psychoanalytischer Verlag.
- . (1942). *The creative unconscious: Studies in the psychoanalysis of art*. Cambridge, MA: Sci-Arts Publishers.
- . (1948). *Masks of love and life: The philosophical basis of psychoanalysis*. (A. A. Roback, Ed.) Cambridge, MA: Sci-Arts Publishers.
- Sachs, Hanns, and Otto Rank. (1916). *The significance of psychoanalysis for the mental sciences*. (Charles R. Payne, Trans.) New York: Nervous and Mental Disease Publishing Co.

### SADGER, ISIDOR ISAAK (1867–1942?)

Austrian physician and psychoanalyst Isidor Isaak Sadger was born in Neuzandec, in Galicia, on December 29, 1867, and died, probably in a Nazi concentration camp, during the Second World War.

An important figure in early psychoanalysis, Sadger began his career as a specialist in nervous diseases who, in 1894, began publishing a series of articles on psychophysiology. One such article, which vaunted the discoveries of Paul Flechsig (who would become physician to Daniel Paul Schreber), was noted when Freud, after reading it, dreamed of the sentence: “It’s written in a positive style” (1900a, p. 296).

A proponent of degeneracy theory, Sadger defined this hereditarian concept as an abnormal reaction of the central nervous system, and he investigated its incidence in the lives of significant writers. In his early writings, Sadger alluded to Freud in discussions of hysteria. He also appears to have attended some of Freud’s university lectures in the late 1890s, about the time he began to practice the various neuropsychiatric therapies. In addition to employing the degeneracy concept, Sadger also evinced considerable interest in Freud’s seduction theory.

In 1906, Sadger joined the group of analysts then gathering around Freud. His disregard for psychoanalytic conventions with patients earned him the disdain of colleagues; he took notes in shorthand during sessions and published them. However, he was regarded by Freud as a “good worker” for his varied research and particularly for his contributions concerning narcissism and homosexuality.

Some of Sadger’s publications were devoted to the medico-legal defense of homosexuality, and he analyzed homosexuals with a view to curing “perversion.” Such patients had to promise—indeed, certify—that they would undergo treatment even if the law did not punish their sexual behavior, and to admit that they possibly already had experienced some feeling for the opposite sex (Sadger, 1908). From these analyses emerged an etiology. The homosexual had a dominating mother and weak, sometimes absent father. Sadger regularly claimed that his homosexual patients recovered childhood memories of a precocious love for a woman, most often the mother. Sadger’s biography of Heinrich von Kleist, published in 1910, took up this theme. While Freud accepted this discovery, and made

use of it in his study of Leonardo da Vinci (Freud, 1910c), he rejected most of Sadger's ideas about narcissism (Sadger, 1908).

Sadger was the first Viennese analyst to employ the term "narcissism," bringing together Wilhelm Fliess's theory of bisexuality and the word "Narzissmus" which had been invented by Paul Näcke about 1899. He developed a theory of the ontogenesis of sexuality based on the concept of childhood seduction, in which sexuality manifested by the adult toward the child is taken up by the child and transformed into a closed circle of adoration. By contrast, Freud created a theory of narcissism in which the role of the object remains to a great extent concealed (Vichyn, 1984).

Sadger ended his work with, and his participation in, the Vienna Psychoanalytic Society about 1930. He may have written a biography of Freud but the manuscript has never been found. Sadger alone among Viennese analysts was either unable or unwilling to profit from his relationship with Freud in order to escape Austria after the German annexation in 1938. He died in the Theresienstadt camp in about 1942.

AUTHOR NAME

*See also:* Applied psychoanalysis and the interaction of psychoanalysis; Heterosexuality; Homosexuality; Lehrinstitut der Wiener psychoanalytischen Vereinigung; "On Narcissism: An Introduction".

### **Bibliography**

Freud, Sigmund. (1900a). The interpretation of dreams. Part I, *SE*, 4: 1–338. The interpretation of dreams. Part II, *SE*, 5: 339–625.

———. (1910c). Leonardo da Vinci and a memory of his childhood. *SE*, 11: 57–137.

Nunberg, Hermann and Federn, Ernst. (1962–75). *Minutes of the Vienna Psychoanalytic Society*. New York: International Universities Press.

Sadger, Isidor. (1908). Psychiatrisch-Neurologisches in psychanalytischer Beleuchtung. (Psychiatry and neurology in the light of psychoanalysis). *Zentralblatt für das Gesamtgebiet der Medizin und ihrer Hilfswissenschaften*, 7–8.

———. (1910). Ein fall von multipler perversion. (A case of multiple perversion). *Jahrbuch für psychoanalytische und psychopathologische Forschungen*, 2.

———. (1921). *Die lehre von den geschlechtsverirrungen (Psychopathia sexualis), auf psychoanalytischer grundlage*. Leipzig-Vienna: F. Deuticke.

Vichyn, Bertrand. (1984). Naissance des concepts: autoérotisme et narcissisme. *Psychanalyse à l'Université*, 936.

---

## **SADISM**

*Sadism* is pleasure derived from inflicting cruelty on another person. Richard von Krafft-Ebing coined the term in reference to the writings of the Marquis de Sade. In "Three Essays on the Theory of Sexuality" (1905d) Sigmund Freud described sadism as the active form in a pair of opposites, masochism being the passive form of the same sexual perversion.

Two pregenital libidinal phases are described, the oral-sadistic (or cannibalistic) stage, and the anal-sadistic stage, which remains active during later libidinal development. During the genital stage sadism becomes linked with the masculine position, owing to the active character of both. In neurotic organization, particularly of the obsessional type, sadism plays an important part, both as an instinctual impulse to be repressed, and because of the ambivalence of the instinctual investment. The case of the "Rat Man," related in "Notes Upon a Case of Obsessional Neurosis" (1909d) is particularly illustrative of sadism, as is the case of the "Wolf Man," described in "From the History of an Infantile Neurosis" (1918b [1914]), which shows that the child often interprets the primal scene as sadistic.

Sexual sadism is propped analytically on certain developmental events: the coming in of the teeth during the oral stage, during which satisfaction coincides with destruction of the object; mastery of the anal sphincter muscles; and muscular development that brings the genitalia under the control of reproductive functions. Freud in addition took into account from the outset a nonsexual type of aggression, in which a need to eliminate an obstacle to instinctual satisfaction also allows the instinct for mastery to be satisfied.

Thus, as he wrote in "Instincts and Their Vicissitudes" (1915c): "Psycho-analysis would appear to show that the infliction of pain plays no part among the original purposive actions of the instinct. A sadistic child takes no account of whether or not he inflicts pain, nor does he intend to do so" (p. 128). It is in this article that Freud gave his most complete account, within the framework of the first theory of the instincts, of the links between sadism and masochism. Sadism, first, can be transformed into masochism by



means of a double reversal, wherein activity is transformed into passivity and the subject is substituted for the object. The same outcome is found in the other pair of opposites described, voyeurism and exhibitionism. Nevertheless, Freud noted that the sexual sadistic component presupposes a prior knowledge of masochism, and that it therefore entails the following contradiction: “The enjoyment of pain would thus be an aim which was originally masochistic, but which can only become an instinctual aim in someone who was originally sadistic” (p. 129).

This contradiction was resolved in 1924 in “The Economic Problem of Masochism,” in which Freud confirmed his earlier intuition from “Beyond the Pleasure Principle” (1920g) of a masochism that could be primary. He posited an erotogenic primary masochism that binds the part of the death instinct remaining within the organism. Sadism in effect results from the diversion outward, through the intermediary of the musculature, of the libidinally bound destructive instinct onto objects. “It is appropriate, then, to call it the destructive instinct, the instinct for mastery, the will to power. Part of this instinct is directly placed in the service of the sexual function, where it has an important function to fill. This is sadism, properly speaking.”

Even in his second version accompanying the introduction of the death instinct, Freud allowed for consideration of sadism in a broad and not necessarily sexual sense, as representing the destructive instinct directed outwards toward the objects. Analysts who deem it unnecessary to adhere to the second theory of the instincts are thus justified in equating sadism and destructiveness, all the more so in that anality, for all its abundant potential for instinctual erotization, also lends itself to the metaphorization, by means of fecalization, of the most radical forms of deanimation (Béla Grunberger). Some authors, such as Jean Bergeret, have even maintained that sadism exists as a fundamental narcissistic violence, well before the emergence of sexuality is clinically revealed in narcissistic structures, and that it is inaccurate to describe it in terms of objects, even pregenital ones. Paul Denis has reassessed the element of mastery present in any instinct, with respect to the aim of satisfaction.

Like Karl Abraham, whom Freud also followed in his conceptualization of sadism and the libidinal stages, Melanie Klein adopted the second theory of the instincts and their dualism, but in her clinical work

she focused on sadism as the main expression of the destructive impulse, giving it considerable and early importance. Its turning back against the subject is what puts him or her in danger.

Other authors, such as André Green and Benno Rosenberg, have taken further Freud’s conception of the fusion of life and death instincts prior to any sadism, which thus becomes a projected masochism, and accordingly they see sadism as a protection against the threat of the death instinct and its deobjectivizing aim, particularly in borderline states in which primary anality (Green) intervenes against disintegration and its destructive consequences (Rosenberg). In such a view, sadism protects the individual just as masochism does, but with a more secure external object. This is not always the case, however, since in melancholia incorporation of the object endangers the subject’s life and illustrates the threat of the superego’s sadism toward the ego, which is also present, in a less severe form, in self-punishment.

DENYS RIBAS

*See also:* Allergy, Ambivalence; Anality; Childhood; Compulsion; Cruelty; Dipsomania; Eroticism, anal; Eroticism, urethral; Hatred; Imago; Infantile sexual curiosity; Jouis-sance (Lacan); Kantianism and psychoanalysis; Masochism; Mastery; Mastery, instinct for; Melancholia; “Notes upon a Case of Obsessional Neurosis” (Rat Man); Object, change of/choice of; Organization; Phallic mother; Phobias in children; Pregenital; Primal scene; Psychosexual development; Reaction-formation; Rite and ritual; Sadomasochism; Stage (or phase); Stammering; Tics; Ulcerative colitis; “Vagina dentata,” fantasy of; Violence, instinct of.

### **Bibliography**

- Freud, Sigmund. (1905d). Three essays on the theory of sexuality. *SE*, 7: 123–243.
- . (1915c). Instincts and their vicissitudes. *SE*, 14: 109–140.
- . (1924). The economic problem of masochism. *SE*, 19: 155–70.

---

## **SADOMASOCHISM**

Sadism and masochism represent contrasting forms of pleasure derived from sexual excitation linked to cruelty and the infliction of pain. While both currents

are present in any given individual, they also represent pregenital links in an intersubjective context in which one partner is the sadist and the other the masochist. Sadomasochism may have an oral component but takes on characteristic form during the anal sadistic stage.

In *Three Essays on the Theory of Sexuality* (1905d), Freud pointed out that sadism and masochism, terms that first gained currency in the work of Richard Krafft-Ebing, “are habitually found together in the same individual” and “occur together regularly as pairs of opposites” (pp. 159–60). Freud eventually generalized this dynamic to psychic structures as a whole, when he posited the relations governing the mental agencies in his second topography. Thus the superego’s sadism toward the ego figures prominently in the idea of self-punishment and moral masochism. Sadomasochism may also characterize relationships between individuals, regardless of gender, and even if the context is a normal sexual relationship.

Sadomasochism may be viewed as a regression in the face of castration anxiety, provoked by the oedipal conflict and associated with the perception of the anatomical differences between the sexes. This interplay can be seen in cases of obsessional neurosis—for example, with the “Rat Man” in “Notes upon a Case of Obsessional Neurosis” (1909d). Freud also found sadomasochistic aspects to the oedipally tinged autoerotic fantasies discussed in “A Child Is Being Beaten: A Contribution to the Study of the Origin of Sexual Perversions” (1919e). In general, Freud’s original conception of sadomasochism developed from his early instinct theory, which included a drive to mastery without a sexual aim.

However, in terms of the genesis of the sadism and masochism, Freud eventually gave pride of place to the latter, which he discussed first in 1915 in “Instincts and Their Vicissitudes” in terms of the presence of sexual excitation, and then formulated more generally in “The Economic Problem of Masochism” (1924c), written after the introduction of the death instinct.

In Freud’s later theory, sadomasochism derives its importance and power, so to speak, from a singularly effective form of instinctual fusion that protects the individual from the death instinct by diverting it outward (sadism) or binding it either internally or to an object (masochism). This amounts to a profound explanation of the human capacity to hurt oneself and one another, with both sexual and survival benefits.

This idea can elicit at least as much if not more resistance than infantile sexuality. In dealing with sadomasochism, the analyst may confront resistances that are especially rigid, together with fixations on pregenital object relations, moral masochism, and negative therapeutic reaction.

Freud’s conception of sadomasochism can be clinically validated by role reversal found among sadomasochistic couples, in the establishment of reverse relationships with another partner, and in the special durability of such relationships. The masochist’s victory lies in the fact that the master cannot free him- or herself from the ties that bind.

For analysts who remained faithful to Freud’s first theory of instincts, sadomasochism expresses mental destructiveness, sometimes in the most extreme fashion. For those who preferred the death instinct, sadomasochism instead offers protection from instinctual destructiveness, both internally and through cathexis of a particularly solid object relationship, albeit a pregenital one. Both camps are in agreement in referring to sadomasochism clinically in the analysis of borderline or narcissistic situations in which triangulation gives way to dyadic relations, but they view it differently, as either negative or positive, with regard to destructiveness. This difference would tend to dissolve if it were specified whether internal destructiveness or external destructiveness was involved, because only the latter is taken into account in terms of aggression.

DENYS RIBAS

*See also:* Sadism.

### **Bibliography**

- Freud, Sigmund. (1905d). Three essays on the theory of sexuality. *SE*, 7: 123–243.
- . (1915c). Instincts and their vicissitudes. *SE*, 14: 109–140.
- . (1919e). A child is being beaten: A contribution to the study of the origin of sexual perversions. *SE*, 17: 175–204.
- . (1924c). The economic problem of masochism. *SE*, 19: 155–170.

---

## **SAINTE-ANNE HOSPITAL**

In an edict issued on July 30, 1863, Napoleon III “state approved” that an asylum be established in Paris for

the treatment of mental illness. This hospital was built on a plot of land that was formerly a farm called Saint-Anne, which was in a remote district, but provided forty-four acres that would allow for the construction of a model facility based on the ideas of Jean-Étienne Esquirol and able to accommodate up to 500 patients of both sexes.

The program set out by the committee established by Baron Haussmann included plans for a central admissions office, which was intended to replace immediately the “city madhouse,” where patients would be observed and then redirected to one of ten buildings constructed around the periphery. Work was quickly begun by Charles Auguste Questel, the architect who had drawn up plans for the project under the direction of alienist Girard de Caillaux, and construction was completed in 1866. The chief administrator of the central office was Valentin Magnan, but the “madhouse” was made a special infirmary under the prefecture of police, and when it was decided in 1875 that a clinical chair for mental illness and the study of the brain was to be created, Benjamin Ball won the appointment with the support of Charles Lasègue, under whom he served at the infirmary.

Sainte-Anne maintained a long tradition of competition between academic teaching sponsored by the chair and clinical lectures or seminars given by notable teachers who attracted large audiences. Henri Claude, who held the chair from 1922 to 1939, opened a public clinic (which Édouard Toulouse turned into the Henri-Rousselle Hospital in 1926). From 1936, Claude entrusted consultations in psychoanalysis to René Laforgue, and in 1926 sponsored a series of lectures on psychoanalysis at Sainte-Anne. Under his chairmanship Henri Claude allowed only doctors who had psychoanalytic training to practice at the clinic.

When the war began, Claude was replaced by M. Laignel-Lavastine, but in 1942, the faculty council installed Lévy-Valensi, who was prohibited from teaching under Vichy laws. He was arrested on September 15, 1943, and deported to Auschwitz where he died in the gas chamber three days later. Jean Delay, who served as acting chair after Lévy-Valensi, was named permanent chair in 1946. An analysand of Édouard Pinchon, Delay allowed only analysts to practice in the clinic. Lacan held his seminar in the departmental amphitheater until November 1963, while Henri Ey spoke at the Magnan Amphitheater at Henri-Rousselle Hospital.

But the advent of psychopharmacology, heralded by the International Conference on Thorazine at Sainte-Anne, was to make the hospital one of the birthplaces of neuroleptic treatment, in effect eliminating its role in the development of clinical psychiatry and psychopathology enriched by psychoanalysis.

JEAN GARRABÉ

*See also:* Aimée, the case of; Allendy, René Félix Eugène; Aulagnier-Spairani, Piera; Berman, Anne; Borel, Adrien Alphonse Alcide; Claude, Henri Charles Jules; Congress of French-speaking analysts from Romance-language countries; Delay, Jean; Ey, Henri; France; Heuyer, Georges; *Inconscient, L*; Janet, Pierre; Lacan, Jacques-Marie Émile; Laforgue, René; Mâle, Pierre; Minkowski, Eugène; Nacht, Sacha Emanoel; Narco-analysis; Parcheminey, Georges; Pasche, Francis Léopold Philippe; Perrier, François; Schiff, Paul; Seminar, Lacan's; Sokolnicka-Kutner, Eugénie.

---

## SALPÊTRIÈRE HOSPITAL, LA

On the site of a former gunpowder warehouse for the military, the “Salpêtrière,” Louis XIII constructed a building that would become part of the General Hospital of Paris and used to house beggars. The project was part of the general cleanup of the city that resulted from the edict published in 1656 by Louis XIV.

For more than two decades the Salpêtrière Hospital was used to house women. They lived in different buildings depending on the reason for their confinement (beggars, prostitutes, criminals, the ill). Gradually the facility was transformed into an asylum. Shortly before the Revolution of 1789, Philippe Pinel, who had arrived from the Hospital of Bicêtre (the men's asylum), working with the director, Cusin, introduced patient control methods similar to those he had already put into effect at Bicêtre.

When, in 1862, Jean Martin Charcot joined the General Hospital, it became his job to care for the women in the asylum. He began conducting clinical and anatomical-pathological research, which led to the foundation of rheumatology and neurology in France.

While conducting research on neuropathology (the anatomical study of infantile brain diseases), Freud, in 1895, requested a grant to study at the Salpêtrière.

Coincidentally, Charcot had just begun a critical revision of the pathogenesis of hysteria. Although Charcot had long believed in the organic nature of full-blown neurosis and in animal magnetism, when Freud came to attend his lectures (October 1885-March 1886), his approach was based on the psychological nature of hysteria, where the symptom was believed to result from a voluntary refusal to function. Hypnosis had no therapeutic advantage. It could, however, “experimentally” produce symptoms illustrating the role played by suggestion in their pathogenesis.

Freud was deeply influenced by Charcot and his ideas. Extremely disappointed by his welcome in Paris (which perhaps led to his life-long antipathy for the French), he idealized Charcot to the extent of calling one of his sons Martin in his honor. In 1889 he stopped in Nancy (the rival school) to deepen his understanding of hypnosis. However, he remained faithful to the teachings of the Salpêtrière, which held that the effect of hypnotic suggestion is observed only in subjects who are predisposed to it and that hysteria is the result of this predisposition. On his return to Vienna, Freud found that Joseph Breuer maintained the same position regarding hysteria.

Several years later, in 1890, Pierre Janet, with Charcot’s support, opened a psychopathology laboratory that allowed him, in spite of the organicist revisionism of Joseph Babinski and Pierre Marie, to continue his own clinical work, until Jules Déjerne had him replaced in 1910.

DANIEL WIDLÖCHER

*See also:* Charcot, Jean Martin; Congrès International de l’Hypnotisme Expérimental et Scientifique, Premier; France; Hypnosis; Hysteria; Janet, Pierre.

## SAN FRANCISCO PSYCHOANALYTIC SOCIETY AND INSTITUTE

Psychoanalytic training came to the United States first on the Atlantic seaboard during the 1930s with the establishment of institutes connected with societies in New York, Boston, and the Baltimore-Washington area and then, in one extension westward, in Chicago. A decade later, in the early 1940s, a society and institute were established for the first time west of the Mississippi River, in Topeka, Kansas, by Karl and Will Menninger,

who had been trained psychoanalytically by commuting to Chicago during the 1930s. The Topeka institute was authorized to sponsor all training in the western part of the United States, including California.

The San Francisco Psychoanalytic Institute was established in 1942 as part of the combined California Psychoanalytic Society (a joint society of Los Angeles and San Francisco), both branches being under the direction and supervision of the Topeka society and institute. The initial ten charter members of the new society (in Los Angeles and San Francisco, with one even in New York) were William G. Barrett, Bernhard Berliner, Otto Fenichel, George Gero, Bernard A. Kamm, Jascha Kasanin, Donald McFarlane, Douglass W. Orr, Ernst Simmel, and Emanuel Windholz. Because of the strictures of the American Psychoanalytic Association at that time against the training or membership of nonphysicians (lay analysts), the local nonmedical members of the analytic community (Frances Deri in Los Angeles and Siegfried Bernfeld, Erik Erikson, and Anna Mänchen in San Francisco) had to be designated as honorary members in the local society, not eligible for membership in the American Psychoanalytic Association. Almost all of these charter members in the new California society were refugees from Hitler’s Europe who had immigrated to America in the 1930s. In the latter half of the 1930s they started an informal psychoanalytic study group in San Francisco. This group was open to all interested medical or academic individuals, whether they had been psychoanalytically trained or not. One of the most prominent and active participants of the group was Robert Oppenheimer, the famed nuclear scientist, then at the University of California at Berkeley.

From these initial members, soon joined by others (such as David Brunswick, Ralph Greenson, Norman Reider, and May Romm), the California Psychoanalytic Society grew rapidly in the post-World War II boom years, and soon separated into two organizations. With candidacy limited at the time to psychiatric physicians, the San Francisco Society and Institute drew some candidates from among those in psychiatric training at the two local medical schools, Stanford University and the University of California at San Francisco, but the Departments of Psychiatry at both these medical schools, despite having a number of psychoanalysts on their clinical teaching faculty, were quite unfriendly to psychoanalysis and thus furnished fewer psychoanalytic candidates than the next source.

The greater bulk of the candidates came rather from the Department of Psychiatry of the Mt. Zion Hospital, a local independent Jewish clinical and teaching hospital. Its Department of Psychiatry was established when, in the late 1930s, it recruited as chief the psychoanalyst Jascha Kasanin from Chicago (who was, as stated above, one of the charter members of the California Psychoanalytic Society). Over a three-decade period, he was succeeded as chief by psychoanalysts Norman Reider, Edward Weinschel, and Robert Wallerstein. During this same period the department grew in scope in its training of residents in adult and child psychiatry and also, in accord with its multidisciplinary commitments, in its training of graduate and postgraduate students in clinical psychology and psychiatric social work, growing to a size and prominence that rivaled the training programs at the two medical schools.

This deeply psychoanalytic Department of Psychiatry became so well-known nationally that internship applications to this regional Jewish hospital came from all over the country, with the majority of the interns coming so that they could vie for acceptance into specialty training in the Department of Psychiatry, often to the dismay of the medical and surgical specialties, which competed for interns. Over a fifteen-year period (1973–1988), the Mt. Zion Department of Psychiatry conducted a Doctor of Mental Health program, a five-year experimental program for psychoanalytically informed mental-health practitioners, in content an amalgam of the most relevant aspects of separate disciplinary training in clinical psychiatry, clinical psychology, and psychiatric social work. This program furnished a substantial additional cadre of applicants for full psychoanalytic training at the San Francisco Institute (see Wallerstein, 1978, 1991, for a detailed account of the Doctor of Mental Health).

Until the early 1960s the San Francisco Society and Institute had no building. Its seminars and supervisions were held in institute instructors' and supervisors' private offices, which were primarily in the clusters of medical office buildings surrounding Mt. Zion Hospital, and the monthly scientific meetings were held in the hospital auditorium. When the San Francisco Society and Institute did erect a building, on the site where it still stands, it was kitty-corner from Mt. Zion Hospital. About half the training analysts in the institute, plus other graduate analysts, held part-time salaried administrative and teaching positions on the Mt. Zion Hospital staff, and the Department of Psy-

chiatry at the hospital served much like a prep school for the institute. Psychiatric trainees hoped to enhance their chances to be accepted as a candidate at the institute by impressing their psychotherapy supervisors and their clinical and theoretical seminar leaders who were also institute faculty members.

During the 1960s and 1970s, serious tensions over training issues arose within the Education Committee and threatened to split the institute. One of the principle protagonists in these battles regularly urged Robert Wallerstein, as chief of psychiatry at Mt. Zion Hospital, to join him and other training analysts on the Mt. Zion staff and split from the San Francisco society to found an alternative and rival Mt. Zion Psychoanalytic Society. One of Wallerstein's periodic tasks was to block this move. The internecine difficulties at the institute were finally resolved by the end of the 1970s, and the integrity of the society and institute has not been threatened since.

During the 1980s the long-simmering struggles within the American Psychoanalytic Association came to a head over the issue of accepting nonmedical mental-health professionals (for the most part, clinical psychologists and psychiatric social workers) for full clinical psychoanalytic training. In early 1985 four clinical psychologists, on behalf of a presumed class of many thousands, instigated a lawsuit against the American Psychoanalytic Association for its restrictive training and membership policies, a suit based on Sherman Antitrust grounds. They had the full backing of Division 39, the psychoanalytic division, of the American Psychological Association. (See Wallerstein, 1998, for a detailed accounting of the almost century-long struggle over this issue until its final resolution with the settlement of the lawsuit in 1988.) Many of the leading figures in the San Francisco society and institute had long been in the substantial minority within the American Psychoanalytic Association, who favored opening its doors to full clinical training of nonphysicians. As early as the early 1970s, Stanley Goodman, then the chairperson of the Education Committee of the San Francisco institute, led a finally successful effort to get the American Psychoanalytic Association to accord membership to the dozen or so nonmedical training analysts in institutes around the country, who, to that point, had not been allowed as members, though those they trained were, of course, eligible. This enabled Anna Mänchen, the one nonmedical analyst from the original nonmedical trio of founding

members of the psychoanalytic group in San Francisco and a long-time training analyst at the San Francisco Institute, to become an official member of the American Psychoanalytic Association.

While the 1984–1985 countrywide planning for the lawsuit against the American Psychoanalytic Association was underway, a group of nonmedical mental-health professionals in the San Francisco Bay Area were planning a similar suit, and they were actually given moral and financial support by a significant number of members of the San Francisco institute, including the then chairperson of its Education Committee, Daniel Greenson, even though those who supported the effort were at the same time members of the American Psychoanalytic Association, the parent organization that was planning a vigorous resistance to the lawsuit.

The lawsuit was settled in October 1988, and under the terms of the settlement, nonmedical mental-health professionals became eligible for candidacy, and later membership, in the institutes and societies of the American Psychoanalytic Association, and organized psychoanalytic training centers outside the American Psychoanalytic Association could qualify for membership in the International Psychoanalytical Association if they met its standards. Before the settlement of the lawsuit, membership in the International Psychoanalytical Association was possible in the United States only through the American Psychoanalytic Association.

Although the local group in the San Francisco Bay Area never filed a lawsuit separate from that of Division 39, the individuals involved in the lawsuit went on in 1989 to create a new and separate entity, the Psychoanalytic Institute of Northern California, with strong assistance from some senior members of the San Francisco Psychoanalytic Society and Institutes. The Psychoanalytic Institute of Northern California has had a thriving history of over a decade and in 2004 is in the process of working out membership in the International Psychoanalytical Association, outside the American Psychoanalytic Association. During the rise of the Psychoanalytic Institute of Northern California, several dissident members of the San Francisco Psychoanalytic Society and Institutes also established a new entity, the San Francisco Institute and Society for Psychoanalysis and Psychotherapy, and it too, now more than a decade later, is in the process of working out membership in the International Psychoanalytical

Association outside the framework of the American Psychoanalytic Association.

Thus San Francisco now has three mainline psychoanalytic societies and institutes: the San Francisco Psychoanalytic Society and Institute (since 1942 a member of the International Psychoanalytical Association through the American Psychoanalytic Association), and in addition the Psychoanalytic Institute of Northern California and the San Francisco Institute and Society for Psychoanalysis and Psychotherapy (two recent groups that became members of the International Psychoanalytical Association outside the American Psychoanalytic Association). San Francisco has also been one of the few American cities with a functioning Jungian Psychoanalytic Society and Institute, with a history of more than a half century. For the last decade it has also had a Lacanian training program inaugurated by two Belgium-trained Lacanian analysts, one from Greece and the other from Germany. In 2004 this amounts to five psychoanalytic groups in the San Francisco Bay area, all seemingly thriving and living together in relative harmony. On occasion, scientific events are organized across more than one of them (usually the San Francisco Psychoanalytic Society and the Psychoanalytic Institute of Northern California), and at times, scientific and social events are held for candidates of all five groups.

Yet none of these developments have in any way diminished the intellectual vigor or activity of the original San Francisco Psychoanalytic Society and Institute. With the 1988 opening of training possibilities for nonmedical mental-health professionals, there was a fresh burst of applications from individuals who had for years been hoping for just this opportunity, and the San Francisco Psychoanalytic Society and Institutes has offered a steady curriculum of active classes for candidates through the years since then. This is despite the decline in candidate applications that has beset most institutes of the American Psychoanalytic Association and around the world during these years. This is also despite the collapse of the renowned Department of Psychiatry at Mt. Zion Hospital after the School of Medicine of the University of California at San Francisco took over Mt. Zion Hospital. After Robert Wallerstein left the chair of the university's Department of Psychiatry, which he held from 1975 to 1985 after holding the chair of the Mt. Zion department, his successor as department chair at the university was a biological psychiatrist and neuroscience

researcher not friendly to psychoanalysis. Nonetheless, the flow of psychoanalytic candidates from medical and nonmedical sources has continued unabated.

Morale in the society and institute has been consistently high: the educational program has been pointed to in many circles of the American Psychoanalytic Association as a model for the nation; a supportive San Francisco Psychoanalytic Foundation has been established; and plans are now in the final phase for an improved and enlarged physical headquarters for the society and institute on the same site. Such developments promise to continue. Although the San Francisco society is only middle-sized, and not among the larger groups within the American Psychoanalytic Association, two of its members, William Barrett and Robert Wallerstein, have been presidents of the American Psychoanalytic Association, and two other members, Stanley Goodman and Edward Weinschel, have been chairpersons of the Board on Professional Standards, the educational arm of the American Psychoanalytic Association. And from 1985 to 1989, Robert Wallerstein was president of the International Psychoanalytical Association and Edward Weinschel was secretary.

ROBERT S. WALLERSTEIN

### **Bibliography**

Wallerstein, Robert S. (1978). The mental health professions: Conceptualization and reconceptualization of a new discipline. *International Review of Psychoanalysis*, 5, 377–392.

———. (Ed.). (1991). *The doctorate in mental health: An experiment in mental health professional education*. Lanham, MD: University Press of America.

———. (1998). *Lay analysis: Life inside the controversy*. Hillsdale, NJ: Analytic Press.

---

## **SAN FRANCISCO PSYCHOTHERAPY RESEARCH GROUP AND CONTROL-MASTERY THEORY**

The San Francisco Psychotherapy Research Group (formerly called the Mount Zion Psychotherapy Research Group) was founded in the early 1970s by Joseph Weiss, M.D., and Harold Sampson, Ph.D., both analysts at the San Francisco Psychoanalytic Institute.

A large number of professionals have been associated with the group, which is one of the few in the United States engaged in programmatic research of the therapeutic process and development of a full-scale psychoanalytic theory. The theory is informally known as Control-Mastery Theory, from two of its assumptions: (1) people exercise considerable unconscious *control* of their mental lives (an assumption that contrasts with the view that the unconscious serves only as a repository of drives, blindly seeking expression), and (2) patients enter treatment seeking to *master* their difficulties, although they may be unaware of significant parts of their treatment goals (an assumption that contrasts with the perspective that sees patients as seeking to continue infantile gratifications and resisting modification even of partial symptomatic expression of such impulses). Symptoms stem from “unconscious pathogenic beliefs,” which are inferences about traumatic events, often involving fear of harm to a loved one as a consequence of trying to meet a normal developmental goal (Weiss, 1990; 1993).

These assumptions and several others have been articulated in many publications, in case examples, and especially in formal research. An early phase of the research examined psychoanalytic cases, especially the case of Mrs. C (see Weiss, Sampson, et al., 1986). Among other things, it was shown that patients test their therapists, often unconsciously, by (1) transferring (acting toward the therapist as they had acted toward a parent earlier in life) and (2) turning passive into active (acting toward the therapist as a parent had acted toward them earlier). In both cases, the patient unconsciously hopes that the therapist will not be traumatized as the patient was earlier. When the therapist responds in a way that passes the test, the patient improves immediately (as measured by standard psychotherapy progress measures, as well as several measures developed specifically by the researchers). Other research has investigated short-term psychodynamically oriented psychotherapy, short-term therapy conducted from other theoretical frameworks (for example, cognitive-behavioral therapy), and therapy with elderly clients and several other patient populations. It has been shown that explicit plan formulations can be developed for patients. The more congruent that a therapist’s interventions are with this plan, the greater the improvement (Silberschatz, Fretter and Curtis, 1986).

ROBERT SHILKRET

### Bibliography

Sampson, Harold. (1992). A new psychoanalytic theory and its testing in formal research. In James W. Barron, Morris N. Eagle and David L. Wolitzky (Eds.), *Interface of psychoanalysis and psychology* (pp. 586–604). Washington, D.C.: American Psychological Association.

Silberschatz, G., Fretter, P., and Curtis, J. (1986). How do interpretations influence the process of psychotherapy? *Journal of Consulting and Clinical Psychology*, 54, 646–652.

Weiss, Joseph. (1990, March). Unconscious mental functioning. *Scientific American*, 103–109.

———. (1993). *How psychotherapy works: Process and technique*. New York: Guilford.

Weiss, Joseph; Sampson, Harold; and The Mount Zion Psychotherapy Research Group. (1986). *The psychoanalytic process: Theory, clinical observation, and empirical research*. New York: Guilford.

---

### SANDLER, JOSEPH (1927–1998)

Joseph Sandler, English physician, psychoanalyst, and psychologist, was born in Cape Town, South Africa on January 10, 1927 and died in London on October 6, 1998.

Sandler's family was Jewish. He received his Master's degree in psychology at age nineteen, from the University of Cape Town. He moved to England in the late 1940s to further specialize in psychology, and received his PhD from London University at age twenty-three.

He then began his medical education at University College London, and applied to become a psychoanalyst. In 1952 he qualified as psychoanalyst of the British Psychoanalytical Society, having been trained by the classical Freudian psychoanalyst Willie Hoffer, and then by his wife, Hedwig Hoffer. He became a training analyst at the age of twenty-eight, and specialized also in child analysis. Subsequently he was awarded both a MD and a D.Sc. Sandler had a outstanding career both as theoretician and clinician, but also as an administrator in psychoanalysis. He is considered a central figure in the second half of twentieth century psychoanalysis.

He was editor of the *British Journal of Psychology* (1959–1963), and then became the editor of the *International Journal of Psycho-analysis* from 1969 to 1978, and he founded the *International Review of Psychoanalysis*. He was the first Sigmund Freud professor of psychoanalysis at the Hebrew University of Jerusalem. He then became the first full-time Sigmund Freud professor of Psychoanalysis at London University, until

his retirement in 1992, the year in which was nominated Professor Emeritus.

He held several honorary degrees. He held more than twenty visiting professorships, and was elected President of the International Association of Psychoanalysis in 1989.

As a theoretician, Sandler is remembered for his effort to reexamine and update the theoretical and clinical issues of classical psychoanalysis. He was the leader of the so-called Hampstead Index Project, working with Anna Freud and her colleagues for many years at the Hampstead Child Therapy Clinic during the 1960s and the 1970s. He became more and more interested in trying to bridge the gap between classical Freudian psychoanalysis and the British school of object relations. His close friend Arnold Cooper described his work as “the silent revolution in psychoanalysis.”

Sandler was the author of more than 200 papers and author, editor, or co-editor of forty-four books. The most important of his papers are collected in *From Safety to Superego* (1988), *The Patient and the Analyst*, written in collaboration with Christopher Dare and Alex Holder (1973), and particularly in *Internal Objects Revisited* (1998), which he wrote together with his wife, Anne Marie Sandler.

In addition to being a prolific author, Sandler was also a great facilitator of the work of colleagues and young psychoanalysts. He also pioneered the rapprochement between psychoanalysis and empirical research, creating the annual research conference of the IPA at University College, London. This annual meeting of researchers has been given in his name since his death.

Sandler was married twice, having lost his first wife, and he had three children.

RICCARDO STEINER

*See also:* British Psycho-Analytical Society; Evenly-suspended attention; Great Britain; Identification; *International Journal of Psychoanalysis*, *The*; International Psychoanalytical Association; Israel; Object relations theory; Primary identification; Projective identification; Psychoanalyst; Tavistock Clinic; Technique with children, psychoanalytic; Therapeutic alliance.

### Bibliography

Sandler, Joseph. (1988). *From safety to superego*. New York, London: Karnac Books International Universities Press.



Sandler, Joseph, Dare, Christopher, and Holder, Alex. (1997). *The patient and the analyst: The basis of the psychoanalytic process*. New York: International Universities Press.

Sandler, Joseph, and Sandler, Anne-Marie. (1998). *Internal objects revisited*. London: Karnac Books.

Steiner, Riccardo. (1999). Some observations on 'projection, identification, projective identification. (Joseph Sandler, Ed.) *International Journal of Psycho-Analysis*, 70, 727–35. (Original work published 1989)

Fonagy, Peter; Cooper, Arnold; and Wallerstein, Robert S. (Eds.) (1999). *Psychoanalysis on the move: The work of Joseph Sandler*. London, New York: Routledge.

## SARASIN, PHILIPP (1888–1968)

Philipp Sarasin, the Swiss physician, psychoanalyst, and specialist on psychiatry and psychotherapy, was born at Basel on May 22, 1888, and died there on November 28, 1968.

He came from an old Huguenot family that played an important role in the cultural and economic life of Basel. Having first hesitated between studying Greek or botany, he finally opted for medicine. When he finished his studies in 1915 he worked as a volunteer physician with Eugen Bleuler in Zürich, where he commenced his first Jungian analysis with Franz Riklin. From 1916 to 1921 he worked under Ris as an assistant physician in the Rheinau clinic.

After a short period of analysis with Hanns Sachs, he had the opportunity to encounter Freud at the 1920 congress in The Hague. In spring 1921 he began his analysis with Freud, and in 1924 he set up his own practice in Basel as an independent psychoanalyst.

He was a member of the Swiss Psychoanalytic Society (SGPsa) from its foundation and, following the breakaway of president Emil Oberholzer he replaced him as president from 1928 to 1961. Thanks to his unstinting devotion to Freudian orthodoxy and the fact that he never pushed himself to the fore, he succeeded in saving the SGPsa from crisis and maintained its cohesion through difficult circumstances. Although his contribution was limited in terms of publications and lectures his main activity consisted in adopting "positions that were constantly renewed through considered comments in the course of hundreds of discussions on the scientific and practical questions that arose.... Through his enlightened mind, his rigorous thinking and honesty he formed

the scientific conscience of our country's psychoanalysts" (Parin).

His only psychoanalytic writing of import, on Goethe's *Mignon*, was in his own words the result of his discussions with Freud in the course of his analysis. It is also based on a good knowledge of Goethe's life and work. In it, he analyzes the character of the androgynous young woman, Mignon, who dies as a result of being separated from her beloved, fatherly friend, and the old Harfner, who grows violent in the course of a melancholic episode, as a reworking of the poet's youthful memories.

KASPAR WEBER

See also: Schweizerische Ärztgesellschaft für Psychoanalyse; Société Psychanalytique de Genève; Switzerland (French-speaking); Switzerland (German-speaking).

### Bibliography

Parin, Paul. (1968). Philipp Sarasin: 80 Jahre. *Bulletin der Schweizerischen Gesellschaft für psychoanalyse*, 7, 1–2.

Roazen, Paul. (2001). Interview with Philipp Sarasin. In *The historiography of psychoanalysis*. (p. 167–171) New Brunswick, NJ: Transaction Publishers.

Sarasin, Philipp. (1929). Goethes Mignon. Eine psychoanalytische Studie *Imago*, 15.

———. (1966). Meine richtlinien. *Bulletin der Schweizerischen Gesellschaft für psychoanalyse*, 3, p. 1.

———. (1968). Wie ich zu Freud kam. *Bulletin der Schweizerischen Gesellschaft für psychoanalyse*, Sommer 1968, pp. 1–2.

## SARTRE AND PSYCHOANALYSIS

French philosopher, novelist, and playwright Jean Paul Sartre (1905–1980) attended the École Normale Supérieure, received his accreditation in philosophy, and was a resident at the Institut Français in Berlin during 1933–34. He was awarded, but declined, the Nobel Prize for literature in 1964.

Sartre's first major work, *The Transcendence of the Ego* (1936–1937) published in English in 1957, called into question the interiority of consciousness and, based on Edmund Husserl's phenomenology, he wrote that "the ego is neither formally nor materially in consciousness: it is outside, in the world. It is a being of the world, like the ego of another." The subject does

not possess himself and consciousness, “defined by intentionality,” provides no privileged self-knowledge because, as Sartre writes, “My I, in effect, is no more certain for consciousness than the I of other men. It is only more intimate.” These ideas formed the springboard for a radical critique of introspection, self-knowledge, and inner life.

Sartre developed his ideas further in *Being and Nothingness* (1943). In this text he suggested that Sigmund Freud’s work (which he characterizes as “empirical”), in his estimation, represents a provisional formulation, subject to critique, of what he calls (more by reference to Søren Kierkegaard than to Ludwig Binswanger) “existential” psychoanalysis. He postulates the principle that the human being is a totality, expressed completely through fortuitous conduct. “In other words there is not a taste, a mannerism, or a human act which is not revealing” (p. 568). The goal, to elucidate the actual behavior of human beings, is based on “the fundamental, preontological comprehension which man has of the human person” (p. 568). All conduct symbolizes and conceals, in various ways, the basic choice of every individual subject. Each person must be unveiled and revealed, as Sartre himself would attempt to do with Jean Genet (1952) and Gustave Flaubert (1971–72). With this as a starting point, Sartre moves on to discuss the similarities and differences between Freudian psychoanalysis and what he calls existential psychoanalysis.

In terms of similarities, both analysis and existential psychoanalysis “consider the human being as a perpetual, searching, historization. Rather than uncovering static, constant givens they discover the meaning, orientation, and adventures of this history” (p. 569). With knowledge anterior to logic, the subject has absolutely no privileged capacity for self-knowledge, while conflicts and projects can be apprehended only from the point of view of the other.

But there are also radical differences. Most decisive, according to Sartre, is that for Freud the libido is an irreducible psychobiological given. By contrast, Sartre suggested that the subject’s own demarche is centered on choices that cannot be constituted in advance and which vary with each individual. “For human reality there is no difference between existing and choosing for itself” (p. 572) because “consciousness is a being, the nature of which is to be conscious of the nothingness of its being” (p. 47).

In sum, from a somewhat dated view of Freud’s work, Sartre fashions a critique that views psychoanalysis as an acceptable albeit awkward and provisional expression of what will become existential psychoanalysis, while on a practical level it is more successful. “Empirical psychoanalysis, to the extent that its method is better than its principles, is often in sight of an existential discovery, but it always stops part way” (p. 573).

GEORGES LANTÉRI-LAURA

*See also:* Action-language; Determinism; France; *Freud, the Secret Passion*; Phenomenology and psychoanalysis; Politzer, Georges; Thought-thinking apparatus.

### **Bibliography**

- Sartre, Jean Paul. (1972 [c1957]). *The transcendence of the ego: An existentialist theory of consciousness*. New York: Octagon Books. (Original work published 1936–1937)
- . (1964 [c1956]). *Being and nothingness: An essay in phenomenological ontology*. Special abridged ed. New York: Citadel Press. (Original work published 1943)
- . (1963). *Saint Genet, actor and martyr*. (Bernard Frechtman, Trans.) New York: G. Braziller. (Original work published 1952)
- . (1976). *Critique of dialectical reason, theory of practical ensembles*. (Jonathan Rée, Ed.; Alan Sheridan-Smith, Trans.) London: NLB; Atlantic Highlands, NJ: Humanities Press. (Original work published 1960)
- . (1981 [1993]). *The family idiot: Gustave Flaubert, 1821–1857*. (Carol Cosman, Trans.) Chicago: University of Chicago Press. (Original work published 1971–1972)

---

**SATISFACTION.** *See* Experience of satisfaction

---

### **SAUSSURE, RAYMOND DE (1894–1971)**

Raymond de Saussure, the Swiss psychoanalyst, was born in Geneva in 1894 and died there on October 19, 1971.

Descending in a direct line from a number of Geneva scientists, Raymond was the son of Ferdinand de Saussure, the founder of modern linguistics. He studied medicine in Geneva and Zürich from 1914 to

1920, then trained as a psychiatrist in Paris, Vienna, and Berlin.

While still very young, Saussure took an interest in psychoanalysis, and in 1919 he became a member of the newly-founded Swiss Psychoanalytic Society. In 1921 he met Freud at the conference in The Hague and began analysis with him in 1921. He then set up in Geneva, practicing essentially as a psychoanalyst until 1937. During the 1920s he began another analysis with Franz Alexander in Berlin. Spreading Freud's ideas to France, he and Charles Odier were among the founders of the Paris Psychoanalytic Society in 1926, the *Revue française de psychanalyse* and the Congress of French-Speaking Psychoanalysts. In 1937 he left Geneva for Paris, where he began a new analysis with Rudolph Loewenstein, but returned to Switzerland in 1939 because of the war. In 1940 Saussure was sent to the United States as part of the Swiss American Fund for Scientific Exchanges. He lived in New York until 1952, became a member of the New York Psychoanalytic Society, took an active role in the training activities of the New York Institute, was Associate Professor at Columbia University, and taught in the Free France university.

Upon returning to Geneva in 1952, Saussure put all his experience and energy into developing psychoanalysis in French-speaking Switzerland. He organized clinical and theoretical training seminars in collaboration with Germaine Guex in Lausanne, with Michel Gressot in Geneva, as well as with Marcelle Spira, a Swiss psychoanalyst trained in Argentina. He also lectured in psychotherapy in the medical faculty of Geneva University. He continued his efforts to promote the development of psychoanalysis not only in his own country—he was president of the Swiss Society for several years—but also internationally, and was one of the vice-presidents of the International Psychoanalytic Association (IPA) from 1955 to 1961. In 1966 he helped found the European Federation for Psychoanalysis. In the late 1960s Saussure lent his support to a movement, coming mainly from candidates in French-speaking Switzerland, for the creation of a psychoanalytic training center. This movement resulted in the inauguration of the Centre Psychanalytique Raymond-de-Saussure (Raymond de Saussure Psychoanalytic Center) in Geneva in 1973, two years after his death. This center for exchange and encounter played a leading role in the expansion of psychoanalysis in French-speaking Switzerland that began in the early 1970s, particularly in Geneva.

*La Méthode psychoanalytique* (The psychoanalytic method; 1922), with a preface by Freud (1922e), surprised the public of the time and was prohibited. "Les fixations homosexuelles chez les femmes névrosées" (Homosexual fixations in neurotic women), a report to the Conference of French-speaking Psychoanalysts, puts forward the original notion of "hermaphroditic narcissism," in order to shed light on identity problems in homosexuality (1929). "Psychologie génétique et psychanalyse" (Genetic psychology and psychoanalysis), a congress report, attempts to reconcile the ideas of Freud and Jean Piaget (1933). *Le Miracle grec* (The Greek miracle; 1939), a psychoanalytic study of the century of Pericles, was burned by the Nazis. In 1959 at the IPA Congress in Copenhagen he presented "The Metapsychology of Pleasure," a reflection on desire, pleasure, and happiness, in their relationship to the conscious and unconscious ego. His bibliography numbers about ninety publications.

Raymond de Saussure was intimately involved in the foundation and development of the Swiss society in 1919 and the Paris society in 1926, as well as the European Foundation for Psychoanalysis in 1966.

JEAN-MICHEL QUINODOZ

*See also:* Character; Congrès de psychanalystes de langue française des pays romans; Fédération européenne de psychanalyse; France; *Revue française de psychanalyse*; Société Psychanalytique de Genève; Société Psychanalytique de Paris et Institut de Psychanalyse de Paris; Switzerland (French-speaking); Switzerland (German-speaking).

### Bibliography

- Roch, Marcel. (1980) À propos de l'histoire de la psychanalyse en Suisse romande. *Bulletin de la Société Suisse de psychanalyse*, 10, 17–30.
- Saussure, Raymond de. (1929). Les fixations homosexuelles chez les femmes névrosées. *Revue française de psychanalyse*, 3, 50–91.
- . (1939). *Le miracle grec*. Paris : Denoël.
- . (1959). The metapsychology of pleasure. *International Journal of Psycho-Analysis*, 22, 649–674.
- Vermorel, Henri. (1994). Raymond de Saussure ou la passion de la psychanalyse. (p. 74) In C. Degoumois (Ed.), *Actes du centenaire de la naissance de Raymond de Saussure*. Genève : Médecine et Hygiène.

## SCHIFF, PAUL (1891–1947)

Paul Schiff—French physician, psychoanalyst, psychiatrist, and neuropsychiatrist known for his work with prisoners—was born in Vienna on August 5, 1891, and died in Paris on May 17, 1947.

Though Austrian by birth, Schiff was culturally French. His father, a foreign correspondent for an Austrian newspaper, settled in Paris when his son was a month old. At the Collège de France, Schiff studied philosophy and was especially influenced by Henri Bergson's lectures on Spinoza (1632–1677). He subsequently studied medicine. During World War I, Schiff, not a French citizen but unwilling to fight in the Austrian army, moved to Switzerland, where he became friends with the novelist Romain Rolland and the poet Pierre-Jean Jouve. Returning to France, he interned in psychiatry at the Asiles de la Seine (Asylums of the Seine) and later served as chief of the psychiatric clinic at Sainte-Anne Hospital in 1927. He married Suzanne Wertheimer, an ophthalmologist.

Analyzed by Eugénie Sokolnicka, Schiff became a member of the Société Psychanalytique de Paris (Paris Psychoanalytic Society) in 1928. He was also a founding member of Évolution psychiatrique, a medical organization for French psychoanalysts. He worked with Édouard Toulouse at the Henri-Rousselle Pavillion, where he directed a clinic for sex-related disorders until 1936.

Increasingly drawn to criminology, Schiff was appointed neuropsychiatrist of prisons in 1935. The same year, at the Ninth Conference of French-Speaking Psychoanalysts, he presented the paper "Psychoanalysis and the Paranoias." In his work on criminality, Schiff established an intellectual foundation for cross-disciplinary research employing a range of different perspectives, including the biological bases of behavior and the role of unconscious conflict. But World War II intruded, and his projected treatise on criminology remained unpublished. In 1938, with Daniel Lagache and others, Schiff founded the publication *Psychologie Collective* (Collective psychology), which terminated with the war.

Schiff enlisted as a battalion physician before returning to Paris after the 1940 defeat of the French forces. He and his wife both entered the Resistance and then joined the Free French in Algeria; he was later taken prisoner in Germany. Back in Paris after the end of the war, he immediately returned to his work with

prisoners, published actively, but suddenly died of a stroke just two years later.

CLAIRE DOZ-SCHIFF

*See also:* Congrès des psychanalystes de langue française des pays romans; Criminology and psychoanalysis; France; Société psychanalytique de Paris and Institut de psychanalyse de Paris; Second World War: The effect on the development of psychoanalysis.

### Bibliography

Mijolla, Alain de. (1988). Psychoanalysis and psychoanalysts in France between 1939 and 1945. *International Forum for Psychoanalysis*, 12, 136–156.

Schiff, Paul. (1935). Les paranoïas et la psychanalyse. *Revue française de psychanalyse*, 8, 44–105.

———. (1946). La paranoïa de destruction: Réaction de Samson et fantasme de la fin du monde, séance du 25 mars 1946. *Annales Médico-Psychologiques*, 1, 3, 279–289.

Schiff, Paul, and Antheaume, André. (1925, July). La psychanalyse envisagée du point de vue de quelques applications médico-légales. *Encéphale* (July 1925): 400.

## SCHILDER, PAUL FERDINAND (1886–1940)

The Austrian psychiatrist and psychoanalyst Paul Schilder was born in Vienna on February 2, 1886, and died in New York on December 7, 1940.

He was the son of Ferdinand Schilder, a Jewish silk merchant who died when he was three, and Berta Fürth, who favored him over his brother. He attended secondary school and received his medical training in Vienna. He became a medical doctor in 1909, but he also always maintained an interest in philosophy; he earned a doctorate in that field 1922 and in 1928 published *Gedanken zur Naturphilosophie* (Reflections on natural philosophy).

Schilder turned his attention toward neurology and psychiatry and became the assistant of Gabriel Anton in Halle, and later of Paul Flechsig in Leipzig. At this time he published an article on *Encephalitis periaxialis diffusa* (a syndrome that thereafter bore his name), that made him famous in the field of neurology from 1912. In 1914 he published *Selbstbewusstsein und Persönlichkeitsbewusstsein. Eine psychopathologische Studie* (Consciousness of self and personality: a psychological study), a work informed by Edmund Husserl's phenomenology, before serving as a doctor in the First

World War. But it was *Wahn und Erkenntnis. Eine psychopathologische Studie* (Delusion and knowledge: A psychological study), published in 1922, that marked his first real approach to psychoanalysis, despite the fact that on March 22 Sigmund Freud wrote to Karl Abraham: “Today I received—after the Simmel—a monograph extracted from the *Lewandowskysche Sammlung* (notebook number 15): *Delusion and knowledge* by Paul Schilder (Leipzig), which, in its results, is already thoroughly analytical, and which only leaves aside, as is appropriate, the Oedipus complex. Of course, Sch. acts as if these gentlemen had discovered everything themselves, or almost everything. In short, this is how German clinicians are going to ‘appropriate’ our discoveries. All things considered, I vow, it is of no importance.”

In fact, in 1919 Schilder was elected to membership in the Psychoanalytical Society of Vienna, and on March 7, 1920, he presented his first paper, on identification, there. During the same time, he became the assistant, at the Vienna Hospital, of Julius Wagner-Jauregg, who took a somewhat dim view of his interest in psychoanalysis. He was nevertheless appointed *Privatdozent* in 1921 and professor in 1925.

Although his book *Über das Wesen der Hypnose* (On the nature of hypnosis) led Paul Federn to accuse him of plagiarism in 1922, Schilder’s works were nonetheless known and recognized by Freud and psychoanalytic circles. In 1923 he began to elaborate his theory of “body image,” an expression borrowed from the psychiatrists Arnold Pick and Henry Head, in *Le Schéma corporel. Contribution à l’étude du corps propre* (The corporeal schema: contribution to the study of the individual’s own body). He developed Freud’s suggestion that the ego is derived from bodily sensations (elaborated in Freud’s 1923 encyclopedia article, “The Libido Theory”), and he made the body image a formation under construction that brings together perceptions, affects, fantasies, and thoughts, and that plays a fundamental role in human behavior and relations with others. In 1935 Schilder published his most famous work, *The Image and Appearance of the Human Body*. Donald Winnicott, Esther Bick, Piera Aulagnier, Gisela Pankow, Françoise Dolto, and Didier Anzieu are among the many psychoanalysts who subsequently further developed this notion, which is particularly useful for understanding certain psychotic states.

In 1923 he had also published *Seele und Leben* (Soul and life), a prelude to the many works that made him one of the most original and productive thinkers in his

generation of psychoanalysts—but he remained a relatively isolated man, because he did not wish to become linked with Freud, as was attested by his repudiation of the death instinct. However, although Freud, according to Fritz Wittels (1941) reproached him for working in “overly broad dimensions” instead of limiting himself to a microscopic psychoanalysis, he continued to hold him in esteem and in 1927, for example, he advised Marie Bonaparte to attend Schilder’s visits and lectures at the Vienna Hospital. Before her, Anna Freud had gone to learn the essential basics of psychiatry from him and from Heinz Hartmann, Wagner-Jauregg’s other assistant. Schilder was consistently hostile to the practice of psychoanalysis by non-physicians, attached as he was and would remain to his hospital-based psychiatric practice. He also refused to undergo training analysis and publicly maintained its uselessness. Still, his book *Entwurf zu einer Psychiatrie auf psychoanalytischer Grundlage* (Outline for a psychoanalytically based psychiatry), published in Leipzig in 1925, was a pioneering work on psychoanalytic approaches to the psychoses and has been too often neglected by his successors.

In 1928 he traveled to the United States at the invitation of Adolf Meyer and taught for three months at the Henry Phipps Psychiatric Clinic. He left the Vienna Hospital in 1929 and emigrated to the United States, in 1930 becoming medical director of the psychiatric division of Bellevue Hospital and research professor of psychiatry in New York University’s College of Medicine. He married his collaborator Lauretta Bender in 1937. Although he resigned from the New York Psychoanalytic Society that same year, his contributions continued to influence American psychoanalytic thought.

Struck by a car as he was leaving the hospital where his son had been born a few days earlier, Paul Schilder died in New York on December 7, 1940, a short time after the accident.

As Hartmann wrote, “In my view, Schilder’s conception of the psychic apparatus is very close to the ideas that have been developed in recent years in another field, the psychoanalytic psychology of the ego” (cited in Ziferstein). He also stated, in “The Psychiatric Work of Paul Schilder”: “Schilder did more to spread psychoanalytic discoveries among European psychiatrists than, with the exception of Freud, any other psychoanalyst.”

ALAIN DE MIJOLLA

See also: Body image.

### Bibliography

- Hartmann, Heinz. (1944). The psychiatric work of Paul Schilder. *Psychoanalytic Review*, 31, 1, 296.
- Mühlhheitner, Elke. (1992). *Biographisches lexikon der psychoanalyse (die mitglieder der psychologischen Mittwoch-Gesellschaft und der Wiener Psychoanalytischen Vereinigung 1902–1938)*. Tübingen: Diskord.
- Schilder, Paul (1953). *Medical psychology*. (D. Rapaport, Ed.) New York: International Universities Press. (Original work published 1924)
- . (1925). *Entwurf zu einer psychiatrie auf psychoanalytischer grundlage*. Leipzig, Vienne, Zürich: Internationaler Psychoanalytischer Verlag.
- . (1935). *The image and appearance of the human body*. London: Kegan Paul, Trench, Trubner.
- Wittels, Fritz. (1941). Paul Schilder, 1886–1940. *Psychoanalytic Quarterly*, 10, 131–134.
- Ziferstein, Isidore. (1966). Paul Ferdinand Schilder 1886–1940. Psychoanalysis and psychiatry. In *Psychoanalytic pioneers* (F. Alexander, S. Eisenstein, and M. Grotjahn, Eds.) London: Basic Books.

## SCHILLER AND PSYCHOANALYSIS

Johann Christoph Friedrich von Schiller, the German poet and dramatist, was born on November 10, 1759 in Morbach and died on May 9, 1805 in Weimar. He was the last and most exemplary representative of the Sturm und Drang movement before evolving—always in the company of Johann Wolfgang von Goethe, whose friend he became in Weimar—toward the aesthetic humanism of his classical period. He was a fundamental model for Sigmund Freud, whose identification with the poet was so strong that Schiller was a familiar figure in his dreams: for example, the dream about Hollthurn, in which Schiller's birthplace was the object of scorn, analyzed by Freud in *The Psychopathology of Everyday Life* (1901b).

In difficult periods in his self-analysis, Freud's dreams referred to the plays of Schiller, whose sensibility is darker and more violent than Goethe's. Freud had been familiar with these works since his adolescence, and at age fourteen, with his nephew John, had performed an act from Schiller's *Brigands* (1781) depicting the murder of Caesar by his adoptive son, Brutus; he evoked this memory in his associations with the dream "Non vixit" to analyze his rivalry with his brother. Schiller's modernity exalts the "deviltry of

freedom," the main theme of the play that earned its author honorary citizenship in the French Republic.

The twenty-seven quotations from Schiller in Freud's work, as identified in the *Concordance*, attest to his intimate knowledge of the writer, who was also a *Dicterphilosoph* (poet-philosopher) who articulated a theory of the drives: "The animal drives [*Triebe*] awaken and develop the spiritual drives"; he opposed the material drive (*Stofftrieb*) to the form drive (*Formtrieb*). The *Spieltrieb* (play-drive)—which expresses play, the beautiful, freedom, and the total man—is posited as an ideal nexus between the two *Triebe*. It is also the force that drives creation: "It is union of the unconscious and reflection that makes the poetic artist."

In 1910, Freud situated himself in Schiller's wake by distinguishing the sexual instincts from the ego instincts, acknowledging in 1930 that Schiller, with hunger and love, had provided him with an initial "foothold." The poet was again called to the rescue to provide the words to complete an elaboration, dealing with the oceanic feeling that was being held in abeyance: Freud alluded to the poem "Der Taucher" (The diver) to evoke the dangers of the maternal body inhabited by monsters, citing only the diver's ascent toward "the rosy light," to justify his avoidance of submersion in the maternal unconscious. Elsewhere, he used Schiller's poem "The Ring of Polycrates" as an illustration in "The Uncanny" (1919).

Ultimately, Freud considered the age of Goethe to be a prehistory to psychoanalysis, and he credited Schiller for his emphasis on free association as the basis for literary creation.

MADELEINE VERMOREL

*See also:* Ego; Goethe and psychoanalysis; Instinct; Sudden involuntary idea; "Uncanny," The."

### Bibliography

- Freud, Sigmund. (1901b). The psychopathology of everyday life. *SE*, 6.
- . (1920b). A note on the prehistory of the technique of analysis. *SE*, 18: 263–65.
- Hell, Victor. (1974). *Friedrich von Schiller: théories esthétiques et structures dramatiques*. Paris: Aubier.
- Vermorel, Madeleine. (1990). The drive (*Trieb*), from Goethe to Freud. *International Review of Psychoanalysis*, 17, 249–56.

———. (1995). La pulsion, de Goethe et de Schiller à Freud. In *Freud, judéité, lumières et romantisme*. (p. 133–49) (H. Vermorel, et al, Eds.) Lausanne: Delachaus and Niestlé.

## SCHIZOPHRENIA

For psychoanalysis, as for medical research and the entire field of mental health, schizophrenia is a complex, baffling, and frustrating disorder. It is not particularly rare, affecting about 1 percent of the population; its distribution is worldwide. A century after Emil Kraepelin created the diagnosis of dementia praecox and its extensive symptomology—renamed schizophrenia by Eugen Bleuler—it remains poorly understood. In spite of revolutionary advances in biology and neuroscience, no treatment or combination of therapies offers a reliable cure.

Like all the psychotic disorders, schizophrenia was thought from the start to have an organic basis, but Kraepelin was forced describe it as a “functional disorder.” Early age of onset and absence of brain lesions such as might be found in epilepsy or tertiary syphilis, for example, encouraged early analysts to attempt treatment, especially in light of the limitations of other therapeutic modalities. It became plausible to suggest, at least tentatively, that schizophrenia was a psychological disorder that originated, like neurotic conflicts, in infancy and early childhood. The fact that some small but significant percentage of patients experienced full or partial recovery made it a target for therapies of all kinds, including psychoanalysis.

Although Freud himself was skeptical about prospects for successfully treating schizophrenia, the disorder was central to the activity of many early analysts, who often were associated with hospitals for the insane. Karl Abraham’s first letters to Freud concerned psychosis; like Carl Jung, he worked at the Burgholzi Central Asylum and University Clinic in Zurich, which Bleuler directed. In the United States, where psychiatry only gradually became a primarily office practice beginning about 1920, psychiatrists influenced by Freud also worked in asylums. Adolf Meyer and William Alanson White were both hospital-based psychiatrists, as was Harry Stack Sullivan, who reported impressive results with his analytically oriented treatment beginning in the 1920s. Particularly influential, Sullivan’s work led to the creation of a psychoanalytic enclave at Chestnut Lodge in Rockville,

Maryland, devoted to the treatment of patients with schizophrenia and related disorders.

The rapid growth of psychoanalysis as a medical specialty in the United States after World War II affected the way that schizophrenia was perceived, understood, and treated. The broad theoretical reach of psychoanalysis, with its ambitious aims to provide a general psychology, extended to schizophrenia both as an explanatory tool and treatment modality. In retrospect it is clear that as a treatment it was not successful and that the early-childhood environmental deficit model that analysts proposed could not be sustained. At the time, however, without benefit of drugs or a significant knowledge base in neurochemistry, and in the wake of a period during which biological explanations of mental disease had favored eugenics, psychoanalysts appeared to be modern and forward-looking professionals who were making an earnest and humane effort to understand severe psychopathology in terms of developmental deficits.

Psychoanalysis was not seriously affected by the introduction of phenothiazine in the mid-1950s. But the narcoleptics and their successor drugs set the stage for the de-institutionalization of the mentally ill that began a decade later and also opened the way for the dopamine hypothesis, the first of various neurochemical pathways to be implicated in schizophrenia. By the late 1960s the authority of psychoanalysis was eroding, both as therapy and theory, and it had to compete with a diversified marketplace of competing treatments. As psychoanalysis in the United States entered a period of steep decline in the 1980s, its efforts on both a theoretical and clinical level were often held to be of no account. However, one positive outcome of analytic interest in the severe mental disorders, in fact, was a sophisticated and durable typology of what became known as the borderline and narcissistic disorders (Kernberg 1975), which developed along separate lines and found a respected place in clinical psychiatry and mental health practice more generally.

The list of analysts who studied and wrote about schizophrenia is long and includes interpersonalists, ego psychologists, Kleinians and their successors, together with any number who might be described as individualistic or idiosyncratic. Key texts included papers by Paul Federn, Melanie Klein, Harold Searles, and many others. Some analysts published books on schizophrenia that remained in print for decades, such as Frieda Fromm-Reichman’s *Principles of Intensive*

*Psychotherapy* (1950) and Silvano Arieti's *The Interpretation of Schizophrenia* (1955). Arieti served for years as editor of the voluminous *American Handbook of Psychiatry*.

Today, psychoanalysts view schizophrenia through a diversity of lenses. Many if not most would acknowledge the medical consensus that it is essentially a biological disorder and would not recommend the kind of intensive therapeutic efforts employed in the past. Analysts seeking an in media res would hold that analytic therapy can be beneficial while giving up earlier etiological views. A minority of analysts, post-Kleinians and others, continue to view schizophrenia as amenable in a global sense to therapeutic intervention and theoretical elaboration. Although the classic psychoanalytic model of the etiology of schizophrenia is definitively obsolete, all these currents can coexist and develop alongside the diathesis-stress model of the disorder, currently dominant in psychiatry and medicine.

JOHN GALBRAITH SIMMONS

*See also:* Ambivalence; *Anti-Oedipus: Capitalism and Schizophrenia*; As if personality; Basic Problems of Ethnopsychiatry; Blank/nondelusional psychoses; *Character Analysis*; "Claims of Psycho-Analysis to Scientific Interest"; *Collected Papers on Schizophrenia and Related Subjects*; Dementia; Disintegration, feelings of, (anxieties); *Ego Psychology and Psychosis*; Foreclosure; Infantile schizophrenia; Internal/external reality; Language and disturbances of language; "Metapsychological Supplement to the Theory of Dreams"; Narcissism, secondary; Numinous (analytical psychology); "On the Origin of the 'Influencing Machine' in Schizophrenia"; Organic psychoses; Paranoia; Paranoid psychosis; Paranoid-schizoid position; Paraphrenia; Persecution; Psychological types (analytical psychology); *Psychology of Dementia praecox*; *Psychology of the Unconscious, The*; Psychoses, chronic and delusional; Psychotic/neurotic; Psychotic transference; Splitting of the ego; Symbolic equation; Symbolic realization; Thought-thinking apparatus; "Unconscious, The"; *Violence of Interpretation, The: From Pictogram to Statement*; Word-presentation.

### **Bibliography**

- Arieti, Silvano. (1955). *The interpretation of schizophrenia*. New York: Brunner.
- Fromm-Reichmann, Freida. (1950). *Principles of intensive psychotherapy*. Chicago: University of Chicago Press.
- Kernberg, Otto. (1975). *Borderline personality disorders and pathological narcissism*. New York: Jason Aronson.

Shapiro, Sue. (1981). *Contemporary theories of schizophrenia: Review and synthesis*. New York: McGraw-Hill.

Willick, Martin. (2001). Psychoanalysis and schizophrenia: A cautionary tale. *Journal of the American Psychoanalytic Association*, 49, 27–56.

### **Further Reading**

Munich, R.L. (1997). Contemporary treatment of schizophrenia. *Bulletin of the Menninger Clinic*, 61, 189–221.

---

## **SCHLUMBERGER, MARC (1900–1977)**

Marc Schlumberger, the French physician and psychoanalyst, was born in Mayenne on July 26, 1900 and died in Paris on June 26, 1977.

Son of the writer Jean Schlumberger, whose homosexuality he had difficulty in coming to terms with, and a British mother who died prematurely, he studied medicine purely with a view to becoming a psychoanalyst. Dissatisfied with his first training analysis with René Laforgue, he began a second round of analysis with Sacha Nacht. He became an associate member of the Paris Psychoanalytic Society (SPP) on October 17, 1933, and a full member on March 2, 1937. He was secretary of the *Revue française de psychanalyse* from 1934 to 1936. He continued to practice discreetly during the Occupation, forming, along with André Berge, Françoise Dolto and Juliette Boutonier, what they called the "Sainte-Geneviève Quartet." He also contributed to Georges Parcheminey's lectures on psychoanalysis, given at the Sainte-Anne hospital. In 1946 he became secretary of the first bureau of the SPP under John Leuba as president, a position he retained until 1951. He remained true to Sacha Nacht during the 1953 rift and became president of the Society in 1957–1958. While occupying various positions within the SPP and in the training Commission he continued to practice as psychoanalyst until his death.

He stated without reserve that the future of psychoanalysis depended on women and "non-physicians." (Chasseguet-Smirgel J., 1978) Although his colleagues recognized him as an excellent practitioner, the fact that he never overcame his reluctance to write prevented him from being among the leading figures of the SPP. In his first lecture to the SPP in November 1936 he described a case of masculine impotence that improved greatly after the patient admitted to using a dildo as a penis substitute. Although the analysis



was very satisfied with this “cure” and terminated the treatment shortly afterward, the analyst went on to outline elements that could have been brought more to the fore while stressing the unconscious aggressive instinct and the insufficiently explored transference.

The few articles he wrote illustrate his interest in interpreting dreams and studying the transference in the analytic process. He wrote a report: “Introduction à l’étude du transfert en clinique psychanalytique” (Introduction to the study of the transference in clinical psychoanalysis) for the fourteenth Conference of French-Speaking Psychoanalysts in 1951 and, with Serge Lebovici and Maurice Benassy, for the SPP colloquium in Paris in 1958.

An article entitled “Paul,” written directly in English, recounts the short therapy and death of a young epileptic; in it, the depth of Schlumberger’s psychoanalytic thinking combines with the esthetic sense of a talented writer. In his obituary Janine Chasseguet-Smirgel saw the article as the sublimated elaboration of the author’s mourning for his young patient. She also stressed his “great independence of spirit, his humor and the total absence of conformism that his reserve, his courtesy and discretion at first belied.”

His training couch was very much in demand. He analyzed Wladimir Granoff, Evelyne Kestemberg, Pierre Marty, Ruth Lebovici, Moustapha Safouan, Joyce McDougall, Conrad Stein, Georges Devereux, and many others.

JEAN-PIERRE BOURGERON

See also: France.

### **Bibliography**

Chasseguet-Smirgel, Janine. (1978). Hommage à Marc Schlumberger. *Revue française de psychanalyse*, 42, 4, 757–759.

Schlumberger, Marc. (1936). Sur la guérison d’un cas d’impuissance. *Revue française de psychanalyse*, 9, 4, 589–605.

———. (1952). Introduction à l’étude du transfert en clinique psychanalytique. XIVth Congress of French-Speaking Psychoanalysts, Paris, 1951. *Revue française de psychanalyse*, 16, 1–2, 123–169.

———. (1959). Expression du transfert dans les rêves. *Revue française de psychanalyse*, 23, 3, 381–392.

Schlumberger, Marc; Benassy, Maurice; and Lebovici, Serge. (1958). Sur l’utilisation du matériel onirique en thérapeu-

tique psychanalytique chez l’adulte. Introduction. Colloque de la S.P.P., Paris, 1958. *Revue française de psychanalyse*, 23, 1, 7–27.

---

## **SCHMIDEBERG-KLEIN, MELITTA (1904–1983)**

Melitta Schmeideberg-Klein, physician, psychiatrist, and psychoanalyst, was born on January 17, 1904 in Rosenberg, Slovakia. She died in London on February 10, 1983, at seventy-nine.

Melitta was the oldest child and only daughter of Arthur and Melanie Klein. Before the 1914–1918 war, the family moved to Hungary and Melitta grew up and was educated in Budapest. After the war Arthur Klein moved to Sweden and Melanie Klein moved to Rosenberg, where Melitta matriculated in 1921. She joined her mother in Berlin. Melitta worked for and obtained her MD in 1927 from Wilhelms-Universität in Berlin.

In 1924 she met and married Walter Schmeideberg, who was an Austrian psychoanalyst and a friend of Freud, and who had joined the Berlin Society. In 1929 she started her analytic training with Karen Horney at the Berlin Institute, qualifying as an associate member of the Berlin Society in 1931.

In 1927, Melanie Klein moved to London and joined the British Society. In view of the growing anti-Semitism in Germany, the Schmeidebergs also moved to London and joined the British Society. Schmeideberg-Klein was elected an associate member in 1932 and a full member the next year. She wrote many papers and eventually became a training analyst.

Initially she often made use of her mother’s ideas in her papers (1930, 1935). She then went into analysis with Edward Glover in order to deal with her dependence on her mother, whom she hoped would understand. However, following the death of her elder brother Hans in 1934, and her mother’s reaction to it, she became increasingly critical of both her mother’s contributions and her behavior in the Society, as was her analyst, Glover.

As Melitta increased her criticisms, the atmosphere in scientific meetings worsened. With the arrival of numerous colleagues from Vienna in 1938, the theoretical differences became more obvious, together with the fear that the essentials of psychoanalysis were in danger.

When Schmideberg-Klein addressed the “extraordinary business” meetings to discuss these issues, her main contribution was concerned with the effect of Kleinian proselytizing on the conduct of the affairs of the Society, rather than concern about theoretical issues (1942). When Glover resigned from the training committee and from the Society in 1944, Melitta also withdrew from active participation in the Society, and she concentrated on her other interest—the treatment of delinquents.

In 1945 she went to America. There she helped to found the Association for the Psychiatric Treatment of Offenders in New York. After the death of her mother in 1960, she decided to return to Europe. In 1962 she resigned her membership of the British Society, having developed her own form of psychotherapy (1938).

In addition to many scientific papers and reviews, in 1948 she published her book *Children in Need* (1948). In 1957 she started *The International Journal of Offender Therapy and Comparative Criminology* of which she was managing editor.

She died in 1983, unfortunately unable to make a rapprochement with her family or with other psychoanalysts in the British Society.

PEARL H.M. KING

*See also:* Controversial Discussions; Klein-Reizes, Melanie.

### **Bibliography**

Schmideberg, Melitta. (1930). Psychotic mechanisms in relation to the development of civilisation. *International Journal of Psycho-Analysis*, 11, 387–418.

———. (1935). The psycho-analysis of asocial children and adolescents. *International Journal of Psycho-Analysis*, 16, 22–48.

———. (1938). After the analysis... some phantasies of patients. *Psychoanalytic Quarterly*, 7, 122–142.

———. (1991). Paper read at the second Extraordinary Business Meeting. In P.H.M. King, R. Steiner (Eds.), *The Freud-Klein controversies 1941–1945*. London: Institute of Psycho-Analysis-Routledge, p. 92–99. (Original work published 1942)

## **SCHMIDT, VERA FEDEROVNA (1889–1937)**

Vera Schmidt, the Russian educationist, was born in Odessa in 1889 and died in Moscow in 1937.

She was one of the leading figures of the “Silver Age” of psychoanalysis in Russia. Her parents were both physicians and she was particularly attached to her mother, Elisaveta Yanitskaia, who treated children who suffered from neurological disorders. Vera was later to say that her mother had a determining influence on her choice of career.

In 1908 Vera enrolled in the Bestoujev classes in Saint Petersburg. This prestigious establishment was reserved for young girls: it specialized in training educationists and physicians. In 1912 she was brilliantly successful in completing her studies and graduated as a teacher. In 1913 she met Otto Youlievitch Schmidt and they married in the same year. Early in 1917 she worked Kiev in the supplies Committee. It was also at this time that she developed a passion for reading Freud, her perfect German enabling her to read him in the original.

Otto Schmidt shared his wife’s passion for psychoanalysis and in this respect his role merits our attention. He was the only member of a large family of originally German peasants to have a university education. The brilliant young mathematician became a *Privatdozent* (university lecturer) while preparing his PhD thesis in order to become a professor. An enthusiastic supporter of the 1917 Revolution, he enlisted his talents as a scientist and organizer in support of the Soviets. He was a high-ranking functionary in several ministries ranging from public education to finance and the *Gosplan* (State Planning Committee), as well as being vice-president of the USSR Academy for Science. As a scientist he conducted several polar expeditions, exploits that won him a place in schoolbooks.

However, the man had another passion: psychoanalysis. In 1921 and 1926 as vice-president of the coordinating committee of the Moscow Psychoanalytic Society and the Psychoanalytic Institute (with Ivan Ermakov as the head), he financed the publication of the “Library of Psychology and Psychoanalysis,” an important collection, under the directorship of the same Ermakov. Still via the Coordinating Committee, and thanks to his government posts, Otto Schmidt provided the necessary means for psychoanalytic institutions. In 1917 the committee moved from Petrograd to Moscow and the Schmidts moved also. Vera worked in the Childhood department of the Ministry for Public Education. She applied herself to an in-depth reading of Freud’s works, as well as writings by other western psychoanalysts.

August 1921 saw the opening of the experimental child laboratory Home (Detski Dom), which was to be her life's work. Vera had no psychoanalytic training, but her publications on the experiment and the work methods of the Home (which she herself translated into German for foreign reviews) were greatly appreciated by her colleagues in the West. Moreover, Vera kept a day-to-day detailed diary of the development of her son, Vladimir Schmidt, born in 1920. He was nicknamed Volik, not Alik, as erroneously indicated by certain publications on psychoanalysis in Russia. This immense monograph has never been published in Russian, nor translated into any other language.

In early 1923 the Schmidts went to Vienna where they met Freud, with whom they discussed the children's Home and psychoanalytic activities in Russia. They also visited other analysts, most notably Otto Rank and Karl Abraham. Discussions focused mainly on psychoanalysis and the organization of the collective educational system. This constituted a veritable apotheosis for the Russian Psychoanalytic Association, which became an associate member of the International Psychoanalytic Association (IPA) in 1924.

However, as early as mid-1923 problems began to arise for the Home. The threat of ideological censorship cast its shadow over psychology and child education. On August 14, 1925 the ministry for public education decreed the definitive closure of the children's Home. Until 1929 Vera Schmidt was a researcher at the nervous system Study Center attached to the Academy of Science, where she worked on conditioned reflexes. From 1930 to 1937 she conducted research, in the cerebral pathology Experimental Center, into innate illnesses of the nervous system in young children. But she was already seriously ill with a thyroid tumor and her participation in the Tchelouskine polar expedition organized by her husband only contributed to hastening her demise. On July 17, 1937, Vera Schmidt died on the operating table.

IRINA MANSON

*See also:* Detski Dom; Russia/USSR.

### **Bibliography**

Etkind, Alexandre. (1995). *Eros niévozmojnogo-Istoria psikoanalisa v Rossii*. Moscow : Progress; *Histoire de la psychanalyse in Russie*. (B. Berelowitch, Trans.) Paris: Presses Universitaires de France.

Schmidt, Vera. (1920–22). *Le Journal de Volik* (unpublished).

---

### **SCHNEIDER, ERNST (1878–1957)**

A psychoanalytically oriented Swiss educator, Ernst Schneider was born on October 17, 1878, near Liestal, and died in 1957 in Muttenz, near Basel.

A member of a large family living in the countryside around Basel, Ernst entered the Protestant Normal School of Muristalden, near Berne, at the age of sixteen. For five years he was a teacher in a one-room schoolhouse, then pursued studies at the University of Berne. During a year he spent in a pedagogical seminar at the University of Jena, his attention was drawn to the new currents of thought circulating in Germany. Back in Switzerland, in 1903 he headed a course in continuing education for teachers and thereafter, from 1905, the Hofwil-Berne Normal School. There Schneider put into practice his ideas on school reform, wrote instructional manuals for use in the primary grades, and in 1907 founded the *Berner Seminarblätter*, a renowned pedagogical journal that was later renamed *Schulreform*, which he headed until 1920.

Schneider first learned of psychoanalysis in 1910. He then entered into contact with the Swiss Society of Psychoanalysis, underwent analysis with Oskar Pfister and later with Carl Gustav Jung, and participated actively in the summer courses organized by Pfister in 1912 on the relationship between pedagogy and psychoanalysis; he introduced Sigmund Freud's science into his courses at the Normal School, where Hans Zulliger was his student. Recalled from his post as director in 1916, he taught psychoanalysis to educators at the Institut Jean-Jacques Rousseau in Geneva, then, from 1920 to 1928, taught general psychology, psychopathology, and characterology at the University of Riga (Latvia). He then established himself as a therapist in Stuttgart. On his return to Switzerland in 1946, he taught at the Institut de psychologie appliquée (Institute of applied psychology) in Zürich.

In 1926, together with Heinrich Meng, whom he had met in 1922 at the Berlin Congress (where he also met Freud), he founded the *Zeitschrift für psychoanalytische Pädagogik* (Revue of psychoanalytic pedagogy). He was an active contributor, publishing numerous articles on the relationship between the two sciences and on teacher training.

An independent thinker who was passionate about pedagogy and open to new ideas, Schneider was more a practitioner than a theorist. Still, his institutional activity promoting an educational model informed by Freud's discoveries is worth remembering.

JEANNE MOLL

See also: Switzerland (French-speaking); Switzerland (German-speaking).

### **Bibliography**

Moll, Jeanne. (1989). *La pédagogie psychanalytique. Origine et histoire*. Paris: Dunod.

Schneider, Ernst. (1929). Psychoanalyse und lehrerbildung. *Zeitschrift für psychoanalytische Pädagogik*, 3, 237–251.

## **SCHREBER, DANIEL PAUL (1842–1911)**

Daniel Paul Schreber, the subject of Freud's famous retrospective case history, was born on July 15, 1842, in Leipzig, and died in April 1911 in the state mental asylum at Leipzig-Dösen.

In 1893 Paul was at the zenith of his legal career, having just been promoted to presiding judge at the Dresden Higher Regional Court, when he suffered a severe mental breakdown. Thereafter he spent about thirteen years of his life in mental institutions, and while at the Sonnenstein Asylum he composed his only book, *Memoirs of My Nervous Illness* (1988), a masterpiece that has since inspired scholars in diverse fields. Freud (1911c [1910]) used the book to illustrate his theory of the causal link between homosexuality and paranoia. This heuristically important essay was an exercise in applied, not clinical, psychoanalysis; it was a hermeneutic, not historical, account of a paradigmatic case of paranoia; it was not about Schreber's life.

Paul's father, the son of Moritz Schreber and Pauline (née Wenck) Schreber, was a physician who specialized in exercise therapy for skeletal and muscular disorders, both with and without appliances. He attained fame with his 1855 book, *Illustrated Medical In-Door Gymnastics*, which may be considered a forerunner of modern rehabilitation medicine. Moritz also published works on child rearing and education and was posthumously immortalized by the eponym "Schrebergarten," or community garden, which he advocated as part of healthful living.

After completing his studies at the well-known Thomasschule (Thomas school), in 1860 Paul began studying law at the University of Leipzig, obtaining his doctorate in jurisprudence in 1869. Two years earlier he entered the ministry of justice and served as judge in a variety of cities in Saxony. In 1878 he wed Otilie Sabine Behr (1857–1912), the daughter of operatic director Heinrich Behr. His family considered the bride unsuitable. A diabetic, Sabine suffered six miscarriages or stillbirths.

Schreber was hospitalized three times with depressive illnesses, all following real and symbolically important losses: in 1884, after he was defeated in elections to the Reichstag; in 1892–1893, after he was made presiding judge and his wife gave birth to a still-born boy; and in 1907, when his mother died and his wife suffered a stroke. He functioned normally after the first (moderate, nonpsychotic) depression, and between the second and third (severe, psychotic) episodes, during which time he raised an adopted daughter.

The second depression (the first psychotic episode) began as a prodrome in the summer of 1893. He experienced anxiety dreams about his illness returning and had a fantasy of what a woman might feel during intercourse. By the fall he had a dramatic explosion of symptoms, including insomnia, agitation, hypochondriacal and nihilistic delusions, and attempts at suicide. He voluntarily returned to the Psychiatric Hospital of Leipzig University, under Paul Flechsig, director of the hospital. Months after admission, his agitated depression evolved into a syndrome that involved prosecutory hallucinations and delusions of sexual abuse and hostile human and divine influences, which Schreber described as soul murder. The human influences he attributed mainly to Flechsig. He also developed elaborate ideas of a fantastic cosmology and religion.

By June 1894, with his wife's consent and collaboration, Schreber was transferred by Flechsig to Sonnenstein. There major depression abated by 1897 but his wishes to be allowed to go home went unheeded. Superintendent Guido Weber (using Emil Kraepelin's taxonomy) diagnosed him with incurable paranoia, and he was declared mentally incompetent, yet his wife remained hesitant. Schreber continued to express rage, and he elaborated fantasies that he was to be transformed into a woman to redeem the world. But he was lucid and able to get along socially. He was also able to write his book and to conduct his own defense

in court, setting a legal precedent and regaining his freedom in 1902.

However paranoia and schizophrenia might be parsed in the history of psychiatry, in psychoanalysis the former came to signify a delusional defense against homosexuality. Freud followed Kraepelin's classification but was more interested in syndromes and character than in psychiatric diagnoses. He developed his dynamic formulation in collaboration with Sándor Ferenczi and in 1908 shared his ideas with Carl Gustav Jung, from whom he learned about Schreber in 1910. Locked into his theory, the universality and validity of which have since been challenged, Freud hypothesized that Schreber had a passive-negative oedipal constellation. He suggested that Schreber experienced through transference a passive sexual desire for Flechsig, transformed into the delusion of soul murder. This conflicted wish, Freud claimed, was pathogenic in Schreber's second illness. It had previously appeared in the prodromal fantasy of what a woman feels during intercourse, a fantasy that occurred before Schreber had any personal dealings with Flechsig. In his delusion of soul murder, Schreber intended the soul murder to indicate that Flechsig betrayed him by banishing him to Sonnenstein.

One should differentiate what may be valid in Freud's dynamic ideas from what remains correct in his interpretation of Schreber. Focusing on Schreber's so-called paranoia, Freud did not seem to consider the possibility of what today would be called a mood disorder; his own "Mourning and Melancholia" would not appear until 1917, after analytic contributions by Karl Abraham and Alphonse Maeder.

Subsequent studies of the Schreber case have brought to light much new material. Zvi Lothane (1992) extended work by William G. Niederland (1974) and Hans Israëls (1989). Schreber's fears of sexual abuse were a result of the psychotic process, not the cause; he suffered from repressed and manifest envy, aggression, and rage. In his illness, his real conflicts and transference relationships were decisive. These included conflicts with his mother (not mentioned by Freud), his relationships with the psychiatrists Flechsig and Weber, his career choice and work as a judge, and conflicts with his wife (which included serious disputes over money). In addition, there was the transfer to Sonnenstein and the incompetency ruling, which doomed his legal career.

On the other hand, Freud did acknowledge that the fantasy of being transformed into a woman, completing the trajectory of the prodromal feminine day-dream, was a self-healing rediscovery of a lost human relatedness. Lothane discovered that Schreber engaged in *nonhomosexual* cross dressing, a vehicle for dealing with heterosexual conflicts by means of diffusion of gender identity arising from identification with woman, mother, and wife.

Although Niederland developed a heuristically fruitful formulation, he departed from Freud significantly by reading Schreber's symptoms as determined not by endogenous wishes but by childhood trauma: paternal sadism alternating with physical seduction. These ideas are unsupported by the extant biographical evidence. For Niederland, Schreber's father was a tyrant who tortured his son with terror-inspiring "machines." In reality, these were rather innocuous appliances. Lothane showed a lack of support for Niederland's inference of such trauma taking place when Paul was three to four years old, or for the idea that the father made use of antimasturbation devices. Israëls first pointed out that the father was unduly demonized. Niederland (1974) suggested that some of Moritz Schreber's ideas were "useful in our effort to unravel a few among the many obscure features of the clinical picture and to make the hitherto incomprehensible aspects of Schreber's delusional system accessible to further investigation" (p. 206). A psychoanalytically informed longitudinal case study supports a reappraisal of the basic facts, premises, diagnoses, and dynamics of Schreber's story. Generally, psychoanalytic method, to be clinically valid, must combine hermeneutics and history.

ZVI LOTHANE

See also: "Psycho-Analytic Notes on an Autobiographical Account of a Case of Paranoia (*Dementia Paranoides*)."

### **Bibliography**

- Freud, Sigmund. (1911c [1910]). Psycho-analytic notes on an autobiographical account of a case of paranoia (*dementia paranoides*). *SE*,12: 1–82.
- Israëls, Han. (1989). *Schreber, father and son*. Guilford, CT: International Universities Press.
- Lothane, Zvi. (1992). *In defense of Schreber: Soul, murder, and psychiatry*. London: Analytic Press.

Niederland, William G. (1974). *The Schreber case: Psychoanalytic profile of a paranoid personality*. New York: Quadrangle.

Schreber, Daniel Paul. (1988). *Memoirs of my mental illness* (Ida Macalpine and Richard A. Hunter, Trans.). Cambridge, MA: Harvard University Press. (Original work published 1903)

## SCHULTZ-HENCKE, HARALD JULIUS ALFRED CARL-LUDWIG (1892–1953)

Harald Schultz-Hencke, the German general practitioner, was born in Berlin on August 18, 1892 and died there on May 23, 1953.

His father, Dankmar Carl Sigbert Schultz-Hencke, a physicist and chemist, founded an Institute of Photography (Lette-Verein) in Berlin, where he taught. His mother, Rosalie Adelaïde May Zingler, a graphologist, claimed to be the natural daughter of Edward VII. She died of tuberculosis in 1902. Schultz-Hencke had a sister, Luanna Asträa, a half-sister, Hanna, and a brother, Walter, who was killed during World War I (on May 29, 1915).

In 1911 he began to study: medicine at Fribourg-en-Brigau (doctorate in 1917), philosophy with Heinrich Rickert, Edmund Husserl, and Martin Heidegger, and psychiatry with August Hoche and Ferdinand Kehler. He volunteered as an army physician in 1914 and in 1915 he joined the Freideutsche Jugend, a German youth organization. Having somewhat mediocre health, he set about perfecting his knowledge of biology (studying fish from the Cichlidae family) and philosophy.

Influenced by Siegfried Bernfeld, he “resolved” to shed light on schizophrenia “with the help of Freud.” In 1922 he did his training analysis with Sándor Radó, then trained in the Berlin Psychoanalytic Institute (BPI). In 1927–28 he lectured there and created, with Otto Fenichel, the Clinical Seminar for “young analysts” (Kinderseminar). His critiques of metapsychology and libido theory, as well as his relatively active therapeutic methods, resulted in his being forbidden to teach, and made him an “enemy within” for the German Society.

First married to Frieda von Brixen, who suffered from acute nephritis, he left her and, after her death, married one of his patients, Gerda Bally, a Swiss half-Jew and former wife of analyst Gustav Bally. They

divorced in 1945. Neither union resulted in any children.

In 1934 he was one of the founding members of the Deutsches Allgemeine Ärztliche Gesellschaft für Psychotherapie (General German Society for Psychotherapeutic Medicine) under Matthias H. Göring, and developed “neoanalysis.” In 1942–43, though not a member of the NSDAP (the Nazi party), he was chief medical officer to the army, before being freed from this to do therapeutic work in the Göring Institute, founded in 1936.

On May 4, 1945, he founded the Institute for Psychopathology and Psychotherapy (IPP) with Werner Kemper, and became its director. The Institute practiced “neopsychoanalysis” (*Neopsychoanalyse*), supposed to be an amalgamation of all psychoanalytic schools, which Schultz-Hencke had created in opposition to classic psychoanalysis. On November 7 of the same year he created the Neopsychoanalytische Vereinigung (Neopsychoanalytic Association). The IPP was then transferred to the Zentralinstitut für psychogene Erkrankungen der Versicherungsanstalt Berlin (Berlin Social Security Central Institute for Psychogenic Diseases), which united the social security and retirement authorities under the directorship of Werner Kemper. The Institute for Psychotherapy was then founded on May 9, 1947.

At the sixteenth Congress of the International Psychoanalytic Association (IPA) in August 1949, a controversy broke out, in which Schultz-Hencke found himself in total opposition to Carl Müller-Braunschweig and he refused to resign from the German Psychoanalytic Society (DPG) because he was convinced that he enjoyed the support of the “progressive forces” in the IPA. This resulted in Müller-Braunschweig creating the Deutsche Psychoanalytische Vereinigung (DPV, German Psychoanalytic Association) on June 10, 1950.

Schultz-Hencke’s request for a chair of psychotherapy at the Charity was refused because of opposition from the DPG (September 26, 1949) which, in accordance with a directive from the Berlin court, opposed his appointment because the candidate already had financial revenues both in East Berlin (Charity) and West Berlin (director of the Institute for Psychotherapy). A brilliant and much respected professor, he was extremely disappointed by this lack of international recognition for his neopsychoanalysis. But in the GDR

his psychoanalysis was the only form recognized until the end of the fifties and the DPG remained under the influence of his teachings until the sixties.

His most outstanding works are: *Einführung in die Psychoanalyse* (Introduction to psychoanalysis; 1927), *Schicksal und Neurose* (Fate and neurosis; 1931), *Der gehemmte Mensch* (The inhibited being; 1940), and *Lehrbuch der analytischen Psychotherapie* (Treatise on analytical psychotherapy; 1951).

REGINE LOCKOT

See also: Allgemeine Ärztliche Gesellschaft für Psychotherapie; Berliner Psychoanalytische Poliklinik; Deutsches Institut für Psychologische Forschung und Psychotherapie (“Institut Göring”); Germany; International Federation of Psychoanalytic Societies; *Psyche. Zeitschrift für Psychoanalyse und ihre Anwendungen*; Psychoanalytic splits.

### Bibliography

Kemper, Werner W. (1973). Selbstdarstellung. In L. Pongratz (Ed.), *Psychotherapie in Selbstdarstellungen*. Bern-Stuttgart: Hans Huber, pp. 259–345.

Schultz-Hencke, Harald. (1972). *Einführung in die psychoanalyse*. Jena-Göttingen: Fischer-Vandenhoeck and Ruprecht. (Original work published 1927)

———. (1931). *Schicksal und neurose*. Jena: S. Fischer.

———. (1982). *Der gehemmte mensch*. Leipzig, Stuttgart: Thieme. (Original work published 1940)

———. (1951). *Lehrbuch der analytischen psychotherapie*. Thieme.

## SCHUR, MAX (1897–1969)

Austrian physician Dr. Max Schur was born September 26, 1897 in Stanislaw, then in the Austro—Hungarian Empire and today part of the Ukraine. He died in New York on October 12, 1969.

He completed his high school education in Vienna after his family moved there in 1914 to escape the advancing Russian army. After attending medical school at the University of Vienna from 1915 to 1920, he had most of his postgraduate training at the Vienna Poliklinik. He remained there as an associate in internal medicine until he left Vienna in 1938.

His psychoanalytic education was less direct. As a medical student he attended Sigmund Freud’s intro-

ductory lectures, which kindled a lifelong interest in psychoanalysis. He had a personal analysis with Ruth Mack Brunswick from 1924 to 1932 and was accepted into the Vienna Psychoanalytic Society in 1932. It was this combination of psychoanalytic orientation and internal medicine that led to his becoming Freud’s physician in 1929, a position he fulfilled admirably until Freud’s death in 1939. In the “biological study,” *Freud: Living and Dying* (1972), Schur tells the full story of this relationship and traces the theme of death in Freud’s life and writings.

After Freud’s death the Schur family emigrated to the United States. Schur resumed his medical practice and obtained a position at the Bellevue Hospital in New York. While there he analyzed several patients with chronic skin disorders and in 1950 published a series of papers on the psychopathology and psychoanalytic treatment of psychosomatic disorders. In 1953 he became a training and supervising analyst and teacher at the Psychoanalytic Institute at the Downstate Medical Center of the State University of New York, where he was appointed Clinical Professor of Psychiatry. His scholarship and critical skills led to an editorial career that included three terms on the editorial board of *The Journal of the American Psychoanalytic Association*, and positions as editor of *Drives, Affects, Behavior Volume 2* (1965), an anniversary volume dedicated to Marie Bonaparte, and co-editor of *Psychoanalysis—A General Psychology* (1966), a volume to honor Heinz Hartman on his seventieth birthday.

He was a founding member Psychoanalytic Association of New York and was its President in 1967 when the officers and board presented him with a festschrift as the most suitable gift for a man with his love of knowledge and learning. He died before it was published as *The Unconscious Today: Essays in Honor of Max Schur* (1971).

By 1950 he had published more than fifty papers on medical subjects, rarely with psychological emphasis. From then on he published a series of clinically detailed and theoretically reasoned psychoanalytic articles and books. The first group of papers, on symptom formation and the development of affects, explored the implications of structural theory, especially from a genetic and adaptive perspective. “The ego in anxiety,” “The ego and the id in anxiety,” and “Comments on the metapsychology of somatization” were instantly influential and his concepts “somatization,” “desomatization,” and “resomatization” have entered the psychoanalytic lexicon. Studying the development of the instinctual drives, Schur compared

ethological and child developmental concepts, as can be seen in his critical discussion of Bowlby's *Grief and Mourning in Infancy* (1960) and "The Theory of the parent–infant relationship." (1962) His monograph, *The Id and the Regulatory Principles of Psychoanalysis* (1966), argues firmly for a structured id and clarifies the pleasure/unpleasure principle. He felt that the idea of the repetition compulsion as a regulatory principle was superfluous.

Schur was a major contributor among those analysts who in the 1950s and 1960s worked to elaborate, integrate, and systematize the theoretical and clinical implications of the later work of Freud, working to expand the ideas in *Inhibitions, Symptoms and Anxiety*, Anna Freud's *The Ego and the Mechanisms of Defense*, and Heinz Hartmann's *Ego Psychology and the Problem of Adaptation*.

ROY K. LILLESKOV

*Work discussed: Freud: Living and Dying.*

*See also:* Annihilation anxiety; Coprophilia; Wiener psychoanalytische Vereinigung.

### Bibliography

- Schur, Max. (1953). The ego in anxiety. In R.M. Loewenstein (Ed.), *Drives, affects, behavior. Essays in memory of Marie Bonaparte*. (p. 67–103). New York: International Universities Press.
- . (1955). Comments on the metapsychology of somatization. *Psychoanalytic Study of the Child*, 10, 119–164.
- . (1958). The ego and the id in anxiety. *Psychoanalytic Study of the Child*, 13, 190–220.
- . (1962). The theory of the infant-parent relationship. *International Journal of Psycho-Analysis*, 43, 243–245.
- . (1966). Some additional "day residues" of "the specimen dream of psychoanalysis." In R.M. Loewenstein, L.M. Newman, M. Schur, A.J. Solnit (Eds.), *Psychoanalysis. A general psychology*. (p. 462). New York: International Universities Press.
- . (1972). *Freud: Living and dying*. New York: International Universities Press.

## SCHWEIZERISCHE ÄRZTEGESELLSCHAFT FÜR PSYCHOANALYSE

The Swiss Psychoanalytic Society (SGPsa), consisting of physicians and non-physicians, was created in 1919.

The Swiss Medical Society for Psychoanalysis, or *Schweizerische Ärztgesellschaft für Psychoanalyse*, is the result of a rift that took place within the first society in 1928.

In 1928 Emil Oberholzer and Rudolf Brun founded a medical society for psychoanalysis, which admitted only physicians as full members, non-physicians being considered as no more than "scientific collaborators or collaborators in their specialty." This new society applied to be admitted to the International Psychoanalytic Association (IPA) in 1929. The central committee of the IPA rejected the application in the following terms: "After careful consideration of the question the central committee feels obliged to reject this application because it deems the reasons given in justification of this new foundation to be insufficient. It deeply regrets the fact that the differences that appeared could not be resolved otherwise than through a rift of the old group." The wording is Anna Freud's.

Oberholzer and Brun explained the reasons for the foundation of the new 1928 society in a very long memorandum. The rift was born out of a desire to reorder and was introduced in opposition to "the membership of non-physicians in the Swiss Psychoanalytic Society," but also in rejection of "pseudo-analysts and physicians to whom psychoanalysis is in fact unknown." The difficulties with regard to the non-physician fraction of the old society crystallized around Oskar Pfister. He was reproached with a variety of things: contenting himself with short treatment periods; being essentially preoccupied with symptoms to the detriment of defenses; practicing propaganda; receiving into the society people who claimed to be psychoanalysts when they had in fact been insufficiently trained; being unable to discuss deep theoretical matters; working insufficiently on his own self-analysis; and using religious faith as a therapeutic lever.

This difficulty seems to have existed from the foundation of the SGPsa. The division of the society into two sections, one medical, the other non-medical, had already been suggested in 1926. It was quite probably Freud's 1926 text on lay analysis (1926e) that led to this foundation.

Sigmund Freud, Max Eitingon and Johan H. W. Van Ophuijsen took the side of the old society. In 1936 the Swiss Medical Society for Psychoanalysis renewed its application for membership of the IPA. Philipp Sarasin, as president of the SGPsa, set up a commission,



comprising Pfister, Kielholz, Zulliger, Christoffel, and Blum, which proposed to recognize the members of the medical Society on condition that they request it and that they accept “Freud’s point of view on the question of lay analysis and upon their agreeing to accept the Oxford ruling by non-physicians.” This report seems to have remained unanswered.

In 1938 some members of the medical Society joined the SGPSa individually just as Oberholzer was emigrating to the United States.

MIREILLE CIFALI

See also: Brun, Rudolf; Oberholzer, Emil; Switzerland (German-speaking).

### Bibliography

Cifali, Mireille. (1990). De quelques remous helvétiques autour de l’analyse profane. *Revue internationale d’histoire de la psychanalyse*, 4, 291–305.

Meerwein, Fritz. (1979). Reflexionen zur Geschichte der Schweizerischen Gesellschaft für Psychoanalyse in der deutschen Schweiz. *Bulletin de la Société suisse de psychanalyse*, 9, 25–40.

## SCIENCE AND PSYCHOANALYSIS

Sigmund Freud defined psychoanalysis as the “science of the unconscious” (*Wissenschaft des Unbewussten*). The use of the German term *Wissenschaft* suggests a particular mode of understanding: *Wissenschaft* is constituted as a system of knowledge organized into a coherent and ordered arrangement of fundamental concepts (doctrine), capable of accounting for empirically observed phenomena (the objects of possible experiments) by means of a method that ensures their intelligibility and verification through controlled reproduction of the experiment. This view of science, which was dominant in the nineteenth century, characterizes a form of rational experimentalism that gradually reduced the meaning of the word “science” to a narrowly defined “phenomeno-technique” (in the coinage of Gaston Bachelard).

Freud’s project to scientifically account for psychic processes appears clearly in 1895 in the introduction to the *Project for a Scientific Psychology*: “In this ‘Project’ the intention is to furnish a psychology that shall be a natural science: that is, to represent psychical processes as quantitatively determinate states of specifi-

able material particles, thus making those processes perspicuous and free from contradiction” (1950c [1895]). At this time he situated his discovery within the field of positivist materialism, where psychic processes are represented by means of the concepts of neurophysiology and the empirical data of clinical research; described, ordered, and reconstructed according to the method of the natural sciences (*Naturwissenschaften*). The construction of a metapsychology, a set of concepts specific to psychoanalysis, would lead Freud to abandon the neurophysiological representations found in the “Project” without renouncing his ideal of science.

Freud’s belief in a “scientific conception of the world,” his fidelity to the positivist ideals of his masters (especially Ernst Brücke) led him, in 1911, to cosign, along with Albert Einstein, David Hilbert, and Ernst Mach, an appeal (*Aufruf*) in favor of the creation of a society to help develop the awareness of positivist philosophy. This belief in the ideals of science can be found throughout his work, up to and including the *Outline of Psychoanalysis* (1940a [1938]), in which he writes: “Whereas the psychology of consciousness never went beyond the broken sequences which were obviously dependent on something else, the other view, which held that the psychical is unconscious in itself, enabled psychology to take its place as a natural science like any other. The processes with which it is concerned are in themselves just as unknowable as those dealt with by other sciences, by chemistry or physics, for example; but it is possible to establish laws which they obey and to follow their mutual relations and interdependences unbroken over long stretches—in short, to arrive at what is described as an ‘understanding’ of the field of natural phenomena in question.”

Freud’s adherence to the ideals of science is tempered by an epistemological relativism remote from a “scientific catechism.” He writes: “It is a mistake to believe that a science consists in nothing but conclusively proved propositions, and it is unjust to demand that it should. It is a demand only made by those who feel a craving for authority in some form and a need to replace the religious catechism by something else, even if it be a scientific one. Science in its catechism has but few apodictic precepts; it consists mainly of statements which it has developed to varying degrees of probability. The capacity to be content with these approximations to certainty and the ability to carry on

constructive work despite the lack of final confirmation are actually a mark of the scientific habit of mind” (1916–17a). In other words, science demands that we renounce beliefs like magic, globalizing visions of the world, and absolute knowledge of metaphysics and religion. The work of the scientist entails the sublimation of epistemophilic sexual drives, which are present in the primal paradigm of the theories and techniques of infantile sexual investigation. Freud raised science to the level of a perfect model of the renunciation of the pleasure principle.

Freud’s need to preserve psychoanalysis from the grip of religion and philosophy did not result in his abandoning it to physicians and scientists. As early as *The Interpretation of Dreams* (1900a) and the *Psychopathology of Everyday Life* (1901b), he took the side of antiquity and popular knowledge against the exclusivity of official science. Throughout his work he manifested this oscillation between art and science, which he discovered that he shared with Leonardo da Vinci. On several occasions he pays homage to the poets and novelists, the true precursors of his own discoveries: “The authors of works of the imagination are valuable colleagues and their knowledge should be held in high esteem, for they have the gift of understanding many things that occur between heaven and earth and of which we have no idea. As for knowledge of the human heart, they exceed us considerably, we humble mortals, for they appeal to sources that are not yet accessible to science” (1908e [1907]).

Freud recognized the role of the imagination in scientific work. This element of fiction within any theory leads him to speak of a “mythology of drives” and the metapsychological “sorcerer.” He identifies a dream element at work in science itself and shows, especially in *Delusions and Dreams in Jensen’s “Gratidiva”* (1907a [1906]), the overdetermination inherent in scientific discourse: science, as a whole, can be used for fantasy. Science, with its origins in dream and fantasy, can withdraw only temporarily behind respect for its methodological protocols and critical rationalism. Psychoanalysis can only maintain its scientificity through the implementation of a method within a given form of practice. This epistemological option appears constant over the development of Freudian thought: “What characterizes psychoanalysis, as a science, is less the material on which it works, than the technique of which it makes use” (1916–1917a).

The ideal of Freudian epistemology has gradually given way to the ideal of analysis, which has sometimes been referred to as an ethic. The scientific ideology to which Freud clung has shown itself to be dated, and has been rejected by modern epistemology. Freud’s initial belief in the positivist demands of science has been beneficial: It has situated the specificity of psychoanalysis within a method capable of elevating resistance and transference, along with their analysis, to the rank of operators of knowledge of the unconscious. Freud refused to construct and describe a particular structure in which concepts, as well as objects, would remain inseparable from a method. But his positivist and realist prejudices sometimes prevented him from recognizing that the psychoanalytic system created its objects as it discovered them.

With Freud, psychoanalysis, by recognizing its debt to poets and scholars, continued to enjoy the prerogatives of one and the privileges of the other, and vice versa, inscribing its praxeological specificity within the interstices of the traditional loci of knowledge. Having done so, and notwithstanding the classical and modern culture of its founder, it participates indirectly in the decompartmentalization of discourse characteristic of postmodernity.

ROLAND GORI

*See also:* Catastrophe theory and psychoanalysis; *Future of an Illusion*, *The*; *Matheme*; Psychoanalytic epistemology; Psychoanalytic research; *Weltanschauung*.

### Bibliography

- Bachelard, Gaston. (1938). *La Formation de l'esprit scientifique: Contribution à une psychanalyse de la connaissance objective*. Paris: Vrin.
- Freud, Sigmund. (1908e [1907]). Creative writers and day-dreaming. *SE*, 9: 141–153.
- . (1916–1917a). Introductory lectures on psychoanalysis. Part I, *SE*, 15; Part II, *SE*, 16.
- . (1940a [1938]). An outline of psycho-analysis. *SE*, 23: 139–207.
- . (1950c [1895]). Project for a scientific psychology. *SE*, 1: 281–387.
- Hoffmann, Christian. (1995). Le manifeste positiviste signé par S. Freud en 1911. *Cliniques méditerranéennes*, 45–46.
- Lacan, Jacques. (1966). La science et la vérité. In *Écrits* (p. 855–878). Paris: Le Seuil.

### Further Reading

Grunbaum, Adolph. (1984). *The foundations of psychoanalysis. A philosophical critique*. Berkeley: University of California Press.

Holt, Robert (Ed.). (1997). *Psychoanalysis and the philosophy of science. Collected papers of Benjamin Rubenstein*. Madison, CT: International Universities Press.

Wallerstein, Robert S. (1986). Psychoanalysis as a science: Response to new challenges. *Psychoanalytic Quarterly*, 55, 414–451.

Weinberger, J. et al. (2000). On integrating psychoanalysis and cognitive science. *Psychoanalysis and Contemporary Thought*, 23, 147–176.

---

## SCILICET

The first issue of the review *Scilicet*, under the direction of Jacques Lacan, appeared in May, 1968 from Seuil, the same publisher that two years earlier had brought out his *Ecrits*. Just seven issues would appear in all, counting two double numbers (2/3 and 6/7), over the next eight years.

The Latin adverbial *Scilicet* (scire licet) means “it goes without saying”; Lacan translated it, as he stated in the first issue of the review, as: “You are permitted to know.”

Beginning with the observation that he had “failed in a teaching project over the course of a dozen years which addressed only analysts,” Lacan added that during four years of teaching at the Ecole Normale Supérieure he had taken an interest in notions of formal mathematics. He wrote, “This review is one of the ways by which I expect success in my school, which operates differently from the so-called Societies, over resistance I encountered elsewhere”

Thus, *Scilicet* was not addressed to analysts but to novices. That was why, punning on the English word *bachelor*, he stated, “I’ve decided to call you *bachelier*, to remind you of your place in this empire of pedantry, now so prevalent that actually entering this world will guarantee you nothing except a cultural sewer.” This comment may be viewed as a harbinger of the revolutionary period of May, 1968.

Texts published in *Scilicet* were to be unsigned, “at least by anybody who would publish as a psychoanalyst.” The no-signature rule appeared to Lacan as “a radical solution... the right one to disentangle the

contortions by which in psychoanalysis experience is forced to reject anything that might change it.”

The decision to publish *Scilicet* was announced in the “Proposition of October 9, 1967...” that introduced the idea of the *passe*, a test that Lacan designed to evaluate students as they advanced from being analysands to becoming analysts. He also made reference to “Nicolas Bourbaki,” the pen name that an influential group of French mathematicians lent to their collective work beginning in the 1930s. “Let us be clear,” Lacan added: “*Scilicet* excludes no one, but that who ever does not appear in it will not be recognized as one of my students.”

Although Lacan listed the names of analysts who wrote for the journal in the next issue (2/3), anonymity for individual articles was maintained. Lacan published a number of interventions in *Scilicet*; these would later be republished in *Autres Ecrits* (2001). Around the same time, another review, *L’Ordinaire du psychanalyste*, also appeared, also with anonymous contributions, under the direction of Francis Hofstein and Radmila Zygouris. Although inspired by Lacan, these analysts had no allegiance to him and their review was a forum in which they could freely discuss clinical matters, providing a counterweight to *Scilicet* that proved a great critical success.

After *Scilicet* ceased publication in 1976 due to Lacan’s loss of interest, it was followed by the first issue of *Ornicar?* in which Lacan published “Peut-être à Vincennes...” Here he reaffirmed his aspirations for the department of psychoanalysis at the University of Vincennes and reiterated his confidence in Jacques-Alain Miller: “Hopefully, the curriculum at Vincennes will include teachings that Freud considered fundamental, enabling the analyst to confirm the findings of his personal analysis, to understand not so much the ends it served as the knowledge of which it made use.” By this time, Lacan seemed to be counting on the school to advance the foundations he laid down. He had furthered efforts to bring to bear mathematically-inspired formulas on psychoanalysis, with a lecture by Jean-Toussaint Desanti, “Reflections on the Concept of Mathesis,” which he introduced at a conference at Sainte Anne on “Psychoanalytic Knowledge,” on December 2, 1971.

JACQUES SÉDAT

See also: École freudienne de Paris (Freudian School of Paris); *Ornicar?*.

### Bibliography

Lacan, Jacques. (2001). *Autres écrits*. Paris: Seuil.

## SCOPTOPHILIA/SCOPOPHILIA

The term *scoptophilia*, subsequently replaced by *scopophilia*, took its place in Anglophone psychoanalytic literature as a translation of the Freudian notion of *Schaulust*, “pleasure in looking,” in the sense of both seeing and being seen, as well as “curiosity.” Freud distinguished between two frequently encountered forms of this partial drive: one active, “voyeurism,” and the other passive, “exhibitionism,” neither of which he would necessarily rank among perversions (1910a [1909]).

As early as 1936, Ernest Jones wrote a critique of Howard C. Warren’s *Dictionary of Psychology* in which he noted that the *Glossary of Psychoanalytical Terms*, which Jones edited in 1924 in preparation for the planned Standard Edition, contained “an important mistake . . . , one which has been widely copied in psycho-analytical literature, namely, the incorrect term *scoptophilia*, which should be *scopophilia*” (p. 247). In 1963, James Strachey gave a more detailed explanation: “I must admit that the Glossary Committee disgraced itself lamentably over at least one word. The question was how to translate ‘*Schaulust*’—the pleasure in looking. Greek terminology was all the rage, and the word ‘*scoptophilia*’ was suggested and accepted with acclamation. It certainly looked a little odd; but nevertheless it passed into all the four volumes of the *Collected Papers* uncriticized. You might have imagined that we should have remembered telescopes and microscopes and so have suspected that the Greek root for looking was something like ‘scop.’ Actually there is a Greek root ‘scopt,’ but what it means is ‘to make fun of.’ And so to this day you may still come upon references to the component sexual instinct of pleasure in derision” (p. 229).

In fact, just as Bruno Bettelheim wrote in *Freud and Man’s Soul*, both terms are wrong and “the monstrosity contrived by Freud’s translators and perpetuated in the *Standard Edition*—“*scopophilia*”—certainly conveys nothing at all” (p. 91). He comments moreover that this seems a betrayal of Freudian thought: “It would admittedly be difficult to find a single English word to express what Freud had in mind with *Schaulust*—a term that combines the German word for lust,

or sexual desire, with that for looking, seeing, or contemplating—but a phrase on the order of ‘the sexual pleasure in looking’ would make his meaning clear; or since ‘lust’ is the near equivalent of the German *Lust* and has the further advantage that it can be used both as a noun and as a verb, it might be preferable to ‘sexual pleasure.’ In either case, the reader would know immediately what is meant. Since we have all repeatedly experienced great pleasure in watching something, in taking it in with our eyes, and have occasionally been ashamed of doing so, or even been afraid to look, although we wished to see, it would be easy to have both a direct intellectual and emotional understanding of Freud’s concept” (p. 90–91).

Several hundred articles by the most illustrious names in psychoanalysis nevertheless testify to the persistence of the use of these two suspect terms up to the present day—a particularly striking example of the absurd errors that can be passed on from text to text.

ALAIN DE MIJOLLA

*See also:* Exhibitionism; Identification with the aggressor; Look/gaze; Voyeurism.

### Bibliography

Bettelheim, Bruno. (1983). *Freud and man’s soul*. New York: Alfred A. Knopf.

Freud, Sigmund. (1910a [1909]). Five lectures on psychoanalysis. *SE*, 11: 7–55.

Jones, Ernest. (1936). Review of the “Dictionary of psychology.” (Howard C. Warren, Ed.) London: Allen and Unwin. *International Journal of Psycho-Analysis*, 17, 247–248.

Strachey, James. (1963). Obituary of Joan Riviere, 1883–1962. *International Journal of Psycho-Analysis*, 44, 228–230.

## SCOTOMIZATION

The term *scotomization*, borrowed from ocular pathology, where *scotoma* refers to a spot in the visual field in which vision is deficient or absent, came into use by young psychiatrists in the 1920s to refer to a lack of awareness of others. René Laforgue, who refers to this origin for the term, proposed the notion in the context of his thinking on schizophrenics and “schizonoia” at the time of his earliest work in psychoanalysis. He believed it would account for his patients’

misapprehension of reality, and explained in a letter of June 10, 1925, to Sigmund Freud that “scotomization corresponds to the wish that is infantile, and therefore not repressed, not to acknowledge the external world but to put the ego itself into its place. In these conditions, the process of repression seemingly has not overcome the primitive stages in the normal way, but, on the contrary, has allowed them to persist.”

Freud was puzzled and rather opposed to this innovation, which seemed to him a bit too “French” in its tendency toward simplification. In a letter to Laforgue dated May 1925, he argued: “A very important point seems to me that in repression (*Verdrängung*) you distinguish a scotomization. I do not believe there are any grounds for this. We have stated that repression means that an instinct is suppressed and that the fact of being conscious is withdrawn from its ideational representation. Why split this unitary process in two? As for the other differences you establish between repression and scotomization, I do not understand them.” He nevertheless accepted Laforgue’s presentation of the notion in the article “*Verdrängung und Skotomisation*” (Repression and scotomization), which appeared in 1926 in the *Internationale Zeitschrift für Psychoanalyse*.

However, he criticized it in a letter of February 18, 1926: “I read your article in German on scotomization from start to finish. I now understand why this concept and its relationship to repression pose such difficulties for me. I note that on one point you have abandoned me. You do not accept the metapsychological view that tries to characterize a psychical event in terms of its dynamic, topographical, and economic aspects—in terms of three coordinates, so to speak. It is especially by disregarding the topographical coordinate that you give up a sort of certainty, whereas it makes itself felt in the whole. You are not concerned with what happens in the three layers of the conscious, preconscious, and unconscious, and phenomena are therefore ambiguous. No doubt you have not dared to present to your compatriots this element of complication and speculation.”

Freud returned to the topic in “Inhibitions, Symptoms and Anxiety” (1926d), citing Laforgue’s notion as an example of the hysterical mechanism “which, by means of restrictions of the ego, causes situations to be avoided that would entail such perceptions, or, if they do occur, manages to withdraw the subject’s attention from them”. But his reflections on lack of awareness

continued in the article “Fetishism,” where he wrote: “If we wish to separate in it [repression] more clearly the vicissitude of the representation from that of the affect and reserve the expression ‘repression’ for the affect, for the vicissitude of the representation it would be correct to say in German *Verleugnung* (disavowal). The term ‘scotomization’ seems to me to be particularly improper, for it evokes the idea that perception has been completely swept away, as in the case where a visual impression strikes the blind spot of the retina. On the contrary, the situation which we are describing shows that perception remains and that a very energetic action has been undertaken to maintain its denial.”

Laforgue attempted a further refinement the following year in “*Überlegungen zum Begriff der Verdrängung*” (Considerations on the notion of repression), but the notion of scotomization did not withstand Freud’s commentaries for long, even in France, where Édouard Pichon had been extremely receptive to it.

If this notion is no longer used today, we can imagine that the discussions to which it gave rise, before the war, and Freud’s refusal to believe that a perception could be purely and simply suppressed, without conflict or any permanent psychic modifications, such as a splitting of the ego (1938), were no doubt not unrelated to what Jacques Lacan based on his translation of *Verwerfung* called “foreclosure.”

ALAIN DE MIJOLLA

See also: Disavowal; Laforgue, René; Pichon, Édouard Jean Baptiste.

### **Bibliography**

- Freud, Sigmund. (1926d). Inhibitions, symptoms and anxiety. *SE*, 20: 75–172.
- . (1927e). Fetishism. *SE*, 21: 147–57.
- Freud, Sigmund, and Laforgue, René. (1977h [1923–33]). Correspondance Freud-Laforgue, préface d’André Bourguignon. *Nouvelle Revue de psychanalyse*, 15 (1977), 235–314.
- Laforgue, René. (1926). *Verdrängung und Skotomisation*. *Internationale Zeitschrift für Psychoanalyse*, 12, 54–65.
- . (1928). *Überlegungen zum Begriff der Verdrängung*. *Internationale Zeitschrift für Psychoanalyse*, 4, 371–74.

## SCREEN MEMORY

A screen memory (like forgetting and amnesia) is a compromise between repressed elements and defense against them. A paradoxical feature of recollections of this kind is they are less childhood memories than memories about childhood, characterized typically by their singular clarity and the apparent insignificance of their content. Important facts are not retained; instead, their psychic significance is displaced onto closely associated but less important details. Displacement is indeed the main mechanism here, as it is in the case of mnemonic symbols or in the forgetting of a proper name, although to some degree condensation may also be present.

The notion of screen memories was first presented by Freud in his paper so named (1899a), an extension of his work on mnemonic symbols and the recollection of trauma in hysteria, a paper written as he was beginning to develop the idea of unconscious fantasy. Later, he concluded that such memories, so long as one knew how to interpret them, supplied the best available source of knowledge about the “forgotten” childhood years (1914g, p. 148). Any memory could be a screen memory inasmuch as one aspect of it screened out something unacceptable to the ego.

In the “Project for a Scientific Psychology” (1950c [1895]), Freud told of Emma, who attributed her phobia to an insignificant scene recalled from adolescence while repressing a more important childhood event. The scene from adolescence, described by Freud as *pseudos*, was in effect a screen memory serving to negate the unacceptable fact of the traumatic seduction of a child by an adult, the memory of which was transformed into age-appropriate amorous feelings of adolescence (pp. 352–54). Freud clarified his notion of the defensive and idealizing falsification of memories in his account of the “Rat Man” case, where he noted “that people’s ‘childhood memories’ are only consolidated at a later period, usually at the age of puberty, and that this involves a complicated process of remodeling, analogous in every way to the process by which a nation constructs legends about its early history. It at once becomes evident that in his phantasies about his infancy the individual as he grows up “endeavours to efface the recollection of his auto-erotic activities” (1909d, p. 206n). The adolescent’s memories concerning his or her childhood thus sought to negate an infantile sexuality incapable of oedipal victory and

replaced it with more heroic ideas by means of a process that Freud compared to the creation of legends and myths.

In “Remembering, Repeating and Working-Through” (1914g), Freud compared screen memories and dreams, observing that their common trait of visual representability enabled them to contain mnemonic traces, albeit in the form of “dream-thoughts.” He added that the analysis of dreams and screen memories facilitated access to the reality of the direct experience of the past just as effectively as the analysis of simple memories: screen memories, he wrote, retained “all of what is essential. . . . They represent the forgotten years of childhood as adequately as the manifest content of a dream represents the dream-thoughts” (p. 148). Could screen memories conceivably be considered a more faithful representation than memories per se? A note added in 1920 to the *Three Essays on the Theory of Sexuality* drew an analogy between screen memories and the fetish which conceals female castration (1905d, p. 154n); and in *Leonardo da Vinci and a Memory of his Childhood*, memory covers up a fantasy of the mother with a penis (1910c, p. 98). This fetishistic aspect of screen memories, as likewise of sensorily intense mnemonic symbols and images, clearly foreshadows Freud’s later view of fetishism.

The key reference here nevertheless remains “Screen Memories” (1899a). In this paper Freud evoked one of his own memories of childhood (though he ascribed it to someone else), in which he saw himself playing with other children in a very green meadow across which vivid yellow flowers were sprinkled; analysis led to a later memory, from adolescence, in which he was in love with a girl in a yellow dress. Thus the childhood memory was in this case screening off a later sexual wish: “there was *no* childhood memory, but only a phantasy put back into childhood” (p. 315). The displacement was flagged by the intensity of sensory representability (a gauge of the persistence of the wish). Sensory representability was not always primary, however: figurative elements could sometimes reflect wishful verbal connections, as, in the present context, when the delicious taste of bread in memory could be interpreted as reflecting the adolescent wish to “earn one’s bread” like an adult.

As early as 1899, then, Freud suspected that any memory that presented itself to consciousness with great intensity might be a screen, so creating a theory of memory as a realm deeply affected by elements of

fantasy: “There is in general no guarantee of the data produced by our memory” (p. 315). Without such a guarantee, psychoanalytical interpretation would place its hopes in the study of repetition (1914g) or on the evidence from analytic constructions (1937d).

Inasmuch as screen memories cover up that which is unacceptable to the ego, they may be considered essentially defensive in nature. Their illusory aspect tends to infect all remembering, which thus may always be suspected of having a screen function. The notion tends to subvert the idea of historical reality, for it prompts the question whether such a reality is the outcome of creative interpretation or of genuine access to mnemonic traces. In analyzing his own screen memories, therefore, Freud developed an idea that implied a new epistemology of time and of the complexity of reality: “as though a memory-trace from childhood had here been translated back... at a later date” (p. 321). “The recognition of this fact must diminish the distinction we have drawn between screen memories and other memories derived from our childhood” (p. 322).

FRANÇOIS RICHARD

*See also:* Adolescence; Bernfeld, Siegfried; Lifting of amnesia; Memory.

### ***Bibliography***

- Freud, Sigmund. (1899a). Screen memories. *SE*, 3: 299–322.
- . (1905d). Three essays on the theory of sexuality. *SE*, 7: 123–243.
- . (1909d). Notes upon a case of obsessional neurosis. *SE*, 10: 151–318.
- . (1910c). Leonardo da Vinci and a memory of his childhood. *SE*, 11: 57–137.
- . (1914g). Remembering, repeating and working-through (Further recommendations on the technique of psycho-analysis II). *SE*, 12: 145–156.
- . (1937d). Constructions in analysis. *SE*, 23: 255–269.
- . (1950c [1895]). Project for a scientific psychology. *SE*, 1: 281–387.

## **SECHEHAYE, MARGUERITE (1887–1964)**

Swiss psychologist Marguerite Secheyaye was born on September 27, 1887, and died in Geneva on June 1, 1964.

The child of an authoritarian mother and an egalitarian father, Marguerite Burdet received a Protestant education, attended a secondary school for girls, and graduated with a diploma in literature and pedagogy. While at the university, she attended Ferdinand de Saussure’s lectures on linguistics and, thanks in part to her notes from that course, Charles Bally and Albert Secheyaye, her husband, established the famous Course in General Linguistics. She also studied psychology and professional orientation at the Institut Jean-Jacques Rousseau, which was directed by psychologist Édouard Claparède. After graduation, she became Claparède’s assistant and opened a private practice as a psychologist.

Psychoanalyst Raymond de Saussure was friends with Marguerite and Albert Secheyaye and, according to their adoptive daughter, Louisa Secheyaye-Duess, “Saussure once asked Marguerite why she would not undergo psychoanalysis. She refused on the pretext that psychoanalysis was too concerned with sexuality and that her religion forbade it. When Saussure replied that she ought not judge a method without having experienced it, Secheyaye quickly admitted as much and the next day began a training analysis with Saussure. According to her own emotional reactions at the time, she seems not to have considered it a serious analysis. This was during 1927–28. Soon thereafter, Saussure advised her to take on cases of her own, to analyze them first under control, then he let her practice on her own.”

A group of analysts used to meet, during the 1930s, at the homes of Saussure and the Secheyayes, including Charles Odier, Henri Flournoy, Gustave Richard, and Georges Dubal. This gathering represented the first circle of analysts in Geneva after those of Charles Baudouin and Sabina Spielrein, who had analyzed Jean Piaget. Louisa Secheyaye-Duess wrote that Secheyaye “had a special influence among this group, gained by daring to show her ignorance while proposing very modern ideas. Everybody admired her mind and her beauty, knowledge, and modesty.”

Marguerite Secheyaye was an attentive reader of Freud and Piaget. Analytic practice with schizophrenic patients led her to develop an original method of psychotherapy. When Freud learned of her research, he wrote her an encouraging note, but also informed her of his doubts. The method she called “symbolic realization” would become her tool in psychotherapy with schizophrenics. In 1950, she published her major

work, *Autobiography of a Schizophrenic Girl*, in which she demonstrated, directly and indirectly, the essentials of her method applied to her patient Renée, whom she would eventually adopt and who would later become a psychoanalyst. Marguerite Sechehaye agreed with Melanie Klein on many issues. For both, the quality of mothering was essential. They corresponded on the decisive importance of the earliest stages of psychic development. Sechehaye had also frequent contacts with renowned analysts such as Marie Bonaparte, René Spitz, Anna Freud, and Donald W. Winnicott.

In 1951–52, at Zurich University, assisted by her daughter, she gave a series of lectures to the physicians of the Burghölzli Psychiatric Clinic. She examined several schizophrenic patients in the presence of the house physicians and taught them the steps of her psychotherapeutic method. Sechehaye also published articles and refined her concept of symbolic realization. In 1962, psychiatrists in Milan honored her with a gold medal. On January 1, 1964, several months before her death, Christian Müller honored Sechehaye with a stirring homage before the Swiss Psychoanalytic Society, noting her influence upon young Swiss psychiatrists and psychoanalysts.

MARIO CIFALI

*See also:* Psychoses, chronic and delusional; Schizophrenia; Switzerland (French-speaking); Symbolic realization.

### **Bibliography**

Sechehaye, Marguerite. (1951). *Autobiography of a schizophrenic girl*. New York: Grune and Stratton.

———. (1956). *A new psychotherapy in schizophrenia: Relief of frustrations by symbolic realization*. New York: Grune and Stratton.

———. (1970, [c1951]). *Symbolic realization*. New York: International Universities Press.

## **SECOND WORLD WAR: THE EFFECT ON THE DEVELOPMENT OF PSYCHOANALYSIS**

The Second World War, like the First and in spite of the upheavals it caused in the psychoanalytic movement, was the origin of the international expansion of psychoanalytic theories and practices. Three principal factors were involved: The Nazi persecutions, by forcing Jewish psychoanalysts to emigrate and by elimi-

nating all references to Freud in occupied Europe, shifted the international core of the movement to America. Freud's death in the first weeks of the world conflict made all psychoanalysts responsible for what would or would not be considered "psychoanalytic," leading to the gradual evolution from an autocratic to a democratic structure within the movement. The Allied victory in 1945, by spreading American culture abroad, promoted interest in liberated Europe in a certain conception of psychoanalysis, understood as a liberalization of behavior and a new understanding of the individual in a "free" Western world, essentially opposed to Soviet totalitarianism.

Anna Freud and Ernest Jones made a determined effort to organize the emigration of Jewish analysts from Europe to countries willing to receive them (Steiner). Once Hitler came to power in Germany in 1933, persecutions against Jews forced many of them to leave professional organizations, emigrate from Germany and leave the famed Psychoanalytic Institute in the hands of Matthias Göring. The "German Institute of Psychological Research and Psychotherapy" attempted to eradicate psychoanalytic theory and practice, and the majority of therapists who remained in Germany compromised themselves during the twelve years the Nazi regime was in existence, although a few of them resisted. John Rittmeister attempted to, and was guillotined in 1943. Karl Landauer died in the Theresienstadt camp, Salomea Kempner in the Warsaw ghetto. In Austria the situation was similar after the *Anschluss*, when analysts were forced to emigrate. Freud and several family members and friends left Austria in 1938. In Italy Mussolini's fascists had, less brutally but just as efficiently, muzzled publishing and destroyed psychotherapy and helped to eradicate support for Freud in Europe, where psychoanalysis had come into being and flourished. There were a number of Hungarian analysts, for example, who had to flee to South America or Australia, where they became active proponents of Freudian theories.

In France, where several psychoanalysts like René Spitz and Heinz Hartmann had gone before the war and where Rudolf Loewenstein and Marie Bonaparte had emigrated after closing their institute and discontinuing the *Revue française de psychanalyse*, some psychoanalysts continued to practice, although discreetly. Only René Laforgue, originally from Alsace, tried to collaborate with the Göring Institute, an attempt that was ultimately unsuccessful. Sacha Nacht joined the



Resistance movement and Paul Schiff joined the Free French forces with whom he fought until the Allied victory.

But it was among the Allies that psychoanalysis found the greatest support, and it was in Allied countries that it flourished to an unprecedented degree. In Great Britain the controversy between Melanie Klein and Anna Freud gave the British Psychoanalytic Society the tripartite structure it subsequently retained. Just as important were the contributions by psychoanalysts to the war effort through selection and psychological care of English soldiers. John Rickman and Wilfred Bion, among others, developed techniques that were the origin of group therapy practices such as the application of psychoanalytic practices to social problems.

In America the influx of refugees disturbed the equilibrium of the American Psychoanalytic Society (APSA), the number of members rising from ninety-two in 1932 to one hundred ninety-two in 1940 and to two hundred forty-seven in 1945. Obviously there were conflicts. In 1941 Karen Horney left the New York Psychoanalytic Society to found, with Harry Stack Sullivan and Clara Thompson, the Association for the Advancement of Psychoanalysis. The European analysts and their students took the reins of the APA and continued the discussions and quarrels that had characterized their behavior prior to emigrating. Some, like Otto Fenichel, who had been politically militant in the past, had to keep their opinions to themselves and adapt to an "American way of life," of which, with the passage of generations, they became the most ardent defenders. We know that the APSA's requirement of a medical degree led to the exclusion of many highly capable analysts, like Theodor Reik, from traditional psychoanalytic organizations; others, like Géza Róheim, were not allowed to teach.

The International Psychoanalytic Association was in turn "Americanized," with Freud's prestigious students taking an increasingly greater part in its management. Their responsibilities also grew through the global expansion of psychoanalysis that emigration had caused and which accentuated the popular vogue for Freudian ideas in the United States. The 1945 Allied victory put an end to the dominance of German as the language of psychoanalysis, and English became the principle vehicle for Freudian theories. This was secured by the publication, between 1953 and 1974, of

the twenty-four volumes of the *Standard Edition of the Works of Sigmund Freud*.

The Cold War, and the time it took for traditional European psychoanalytic organizations to resume their activities in countries not subject to Soviet control, resulted in the unchallenged dominance of Anglo-American ideas for nearly fifty years in both international politics and psychoanalysis.

ALAIN DE MIJOLLA

*See also:* First World War: The effect on the development of psychoanalysis.

### **Bibliography**

La psychanalyse et les psychanalystes dans le monde durant la Deuxième Guerre mondiale. (1988). *Revue internationale d'histoire de la psychanalyse*, 1.

Steiner, Riccardo. (2000). *'It is a new kind of diaspora': Explorations in the sociopolitical and cultural context of psychoanalysis*. London: Karnac.

---

**SECONDARY GAIN.** *See* Gain (primary and secondary)

---

**SECONDARY PROCESS.** *See* Primary process/Secondary process

---

### **SECONDARY REVISION**

Secondary revision first appears in *The Interpretation of Dreams* (Freud, 1900), at the end of the section in Chapter 6 describing the mechanisms of the dream work.

Viewed strictly with respect to dreams, secondary revision is a rearrangement of the seemingly incoherent elements of the dream into a form serviceable for narration. This involves logical and temporal reorganization in obedience to the principles of noncontradiction, temporal sequence, and causality which characterize the secondary processes of conscious thought. Above all, it is instrumental dream censorship and may produce omissions or additions.

But this process, Freud goes on to explain, is also at work in daydreams, which organize remembered materials by “threading them onto the string of desire, between past, present, and future.” Furthermore, dreams may rework such fantasies, since they are just nearby in the Preconscious. Secondary revision may also be found in the symptoms of various afflictions, neurotic or otherwise, involving rationalization, the most extreme instances of which may be seen in obsessional neurosis.

Secondary revision is a concept that has been studied relatively little since Freud (except for rationalization in obsessional neurosis), because analysts have preferred to explore the mechanisms of condensation, displacement, and symbolic representation. However, there is no shortage of promising avenues of research in this realm.

First of all, we might consider its most important modes of operation: the act of putting into words, the translation of dream images into verbal images, and the transformation into narrative structure. This is somewhat akin to the rhetorical modes that effect the translation of visual images into figures of speech or style and, inversely, produce images in the mind of the listener. The difference is that the rhetoric of secondary revision serves the ends of censorship more than those of the drives and the primary processes of the unconscious (Duparc, 1995).

Secondary revision seems to be more or less constituted of ready-made, second-hand rhetorical figures that are already stored in a dictionary of such images without occasioning the emergence of much in the way of the affect or desire of the person using them, in contrast to the novel and creative images produced by the representation of unconscious wish. The images in secondary revision are like the prefabricated fantasies that the dream disposes of like the day’s residues. They might also be compared to symbols, impersonal or collective materials described by Freud as the remains of ancient linguistic identities and cultural artifacts that work against the emergence of the dreamer’s individual unconscious.

For some, the construction of the dream’s narrative is one of its most important aspects, perhaps even its driving force. Dreams are always meant to be told, even if only to oneself, and it is the moment of awakening itself, accompanied by the waning of the paradoxical sleep observed by neurobiologists, that triggers

the transformation of reactualized remembered material into instinctual manifestations and finally into an organized narrative (Dejours, 1986). Moreover, dreams that have undergone secondary revision are, as Freud puts it in *The Interpretation of Dreams*, “dreams which might be said to have been already interpreted once, before being submitted to waking interpretation” (p. 490). This aspect might lead us to reflect upon the deferred effect of intellectual revision which analytic treatment aims for and which assumes, insofar as secondary revision is concerned, the somewhat dubious form of constructions involving a significant temporal element.

As for pathology, the predominance of secondary revision over the other mechanisms of representation in dreams and language produces a hypermanifest discourse, in contrast to living discourse that is capable of breathing and resonating with the various levels of representation and figuration (rhythms of speech, mobile shapes, visual images, living rhetorical figures, and contemporary fantasies tied into a network of primal fantasies).

This discourse is composed of what could be called “manifest mechanisms,” as opposed to representations with multiple meanings that allow for glimpses of latent thought and the return of the repressed. These mechanisms are a caricature of the mechanisms of dream representation: incessant displacement leading to acceleration, a manic flight by thinking, flooding-dreams (manic defense); massive metaphorization that produces uninterpretable symbolic dreams (for example symbolic equations in the dreams of paranoid patients), major ellipses, or traumatic repetitions in the operative thought of certain psychosomatic patients.

FRANÇOIS DUPARC

*See also:* Day’s residues; Displacement; Dream; Dream work; Dream symbolism; Evenly-suspended attention; Manifest; Myth; Working-over.

### **Bibliography**

- Dejours, Christophe. (1986). *Le Corps entre biologie et psychanalyse*. Paris: Payot.
- Duparc, François. (1995). *L’Image sur le divan*. Paris: L’Harmattan.
- Freud, Sigmund. (1900a). *The interpretation of dreams*. SE, 4–5: 1–625.

Guillaumin, Jean. (1972). Le rêveur et son rêve. *Revue française de psychanalyse*, 37 (1–2), 5–39.

### Further Reading

Jacobs, Theodore. (2002). Secondary revision: rethinking the analytic process and technique. *Psychoanalytic Inquiry*, 22, 3–28.

---

## SECRET

A secret is a form of hidden knowledge. The word is etymologically related to excrement and seduction. Secret and excrement are both derived from the Latin verb *cernere* (*crevi*, *cretum*) which means: 1) to sift, to separate, to sort; 2) to discern or distinguish an object from a distance. The prefix “ex” relates to the idea of evacuation by sifting (excrement), the prefix “se” to the idea of separation, setting aside, and preserving (secretion, secret).

The secret has a positive, necessary side and a negative, destructive side. Freud referred to it periodically throughout his work, but gave it a central place that anticipated his later research in “The Uncanny” (1919h). In 1892 the term appeared in his writings with an anal connotation whenever it brought to mind “foul words, those secrets we all know, knowledge of which we force ourselves to hide from others” (“A Case of Successful Treatment by Hypnotism” (1892-93a)). The secret was then associated with unhealthy obsessions in the neuro-psychoses of defense (1894a). In 1900, in *The Interpretation of Dreams* (1900a), Freud interpreted dreams of exhibitionism as a desire to “keep a secret.”

In his discussion of Dora’s secret, masturbation, Freud wrote, “He who has eyes to see and ears to hear knows that mortals cannot keep any secret” (1905e [1901]). In 1906, in “Psycho-Analysis and the Establishment of Facts in Legal Proceedings,” (1906c), Freud distinguished the criminal’s conscious secret from the unconscious secret of the hysteric. In “Infantile Sexual Theories” (1908c), he demonstrated the importance of the parents’ lying and secrecy regarding the question of the child’s origins, which allows the infant to access the secret in turn. “Children, once they have been deceived (the stork theory) . . . begin to suspect that there is something hidden that grownups keep for themselves and for this reason they surround their later research in secrecy.” The parents’ secret is an enigmatic message triggering the birth of thinking in the infant.

In 1919, in his article “The Uncanny” (1919h), Freud gave considerable space to secrets and their transmission. He discussed the various meanings of the secret and its connections with the familiar, meetings, love affairs, sin, intimate organs, commodes, and *oubliettes*. He also quotes Friedrich Schelling, who writes: “We call *unheimlich* anything that must remain secret and which becomes manifest.’ *Heimlich* also designates a ‘place without a ghost.’” Freud goes on to study the theme of the double, and its analysis strangely anticipates the ideas of Nicolas Abraham and Maria Torok on the phantom, the crypt, and the intrapsychic cave, and all the later work on the transmission of the secret across generations: “Doubling of the ego, splitting of the ego, substitution of the ego—the constant return of the similar, repetition of the same traits, characteristics, criminal acts, even the same names in several successive generations.”

Abraham and Torok make an analogy between the work of the phantom and the work of the death drive, both working in silence without being mediated in words. In their article, “De la topic réalitaire: Notations sur une métapsychologie du secret,” they define the phantom as “a formation of the unconscious that is unique in never having been conscious. It is a result of the transition, whose method remains to be determined, from the parents’ unconscious to the child’s unconscious.” They add that the phantom is the “work in the unconscious of another’s inadmissible secret.” The phantoms that haunt the living are “the holes left in us by the secrets of others.” For these authors the phantom is associated with a preservative repression that fixes, immobilizes, and “the present past forms a block of buried reality, incapable of coming back to life without crumbling into dust.”

After 1970 research on the role of the secret and non-symbolization in alienating transgenerational transmission increased. Clinical work increasingly helped illuminate concepts such as non-transmission, the transmission of the inert (with Micheline Enriquez and the heritage of psychosis), the leaping of generations and alienating unconscious identification (Alain de Mijolla, Haydée Faimberg), and failed blocked mourning (Jean Cournut). Incorporation, encryption, psychic fossilization, and unfulfilled mourning are reflections of the work of the negative that is active in the transmission of secrets across several generations. The work of Daniel Stern on affective tuning may, perhaps, serve as an explanatory link to account for this

intergenerational psychic transmission, which continues to remain enigmatic.

Systemic family therapy is also relevant to secrets and their relation to family myths. The oedipal myth is already a history of a family secret. In families it is guilt that creates secrets and all the pathogenic rules that follow from them. Many American family therapists have shown that family secrets (divorce, suicide, madness, incest) can mask an implicit narcissistic wound, a devaluation of self image and family image leading to abnormal behavior in a descendant.

We must not forget that our psychic life can only develop against a background that remains silent, secret—the secret Self of which Winnicott speaks. And along with negative and positive secrets, living transmissions exist alongside deadly transmissions of the secret.

ANNE-MARIE MAIRESSE

*See also:* Boundary violations; Cultural transmission; Free association; Ideational representation; Intergenerational; Phantom; Psychoanalytic treatment; Secret Committee; Thing, the; Truth; “‘Uncanny,’ The.”

### **Bibliography**

- Abraham, Nicolas, and Torok, Maria. (1994). *The shell and the kernel*. Chicago: University of Chicago Press. (Original work published 1971)
- Faimberg, Haydeée. (1988). À l'écoute du télescopage des générations: pertinence psychanalytique du concept. *Topique*, 42, 223–238.
- Freud, Sigmund. (1919h). The “uncanny.” *SE*, 17: 217–256.
- Kaës, René. (1993). “Introduction au concept de la transmission psychique dans la pensée de Freud,” in R. Kaës et al., *Transmission de la vie psychique entre générations*, Paris: Dunod.
- Mijolla, Alain de. (1982). En guise d'ouverture . . . In *Psychanalyse et musique*, Paris: Les Belles Lettres.
- . (1987). Unconscious identification fantasies and family prehistory. *International Journal of Psychoanalysis*, 68, 397–403.

## **SECRET COMMITTEE**

The “Secret Committee” was the name given by Freud to the intimate circle of his closest collaborators. Its members were Karl Abraham, Sándor Ferenczi, Otto Rank, Ernest Jones, Max Eitingon, and Hanns Sachs.

Hanns Sachs revealed its existence for the first time in 1944 in *Freud, Master and Friend*. Since Sachs was himself a member of this mysterious group, which had a profound effect on the construction and extension of the “psychoanalytic movement,” his memoirs must be taken with a grain of salt, especially when it concerns the image of his “hero Freud.” Nonetheless, the information is invaluable for understanding the significance of this group for the psychoanalytic movement and the institutionalization of psychoanalysis.

The “psychoanalytic movement” achieved its organizational goals through the drafting of its first by-laws in 1910 by Freud and Ferenczi. What appears to be an alternate process of institutional development was initiated in 1912 with the formation of the secret committee. The creation of an informal organization within the organization was the result of tension between Sigmund Freud and his Swiss “dauphin” Carl Gustav Jung. Between 1910 and 1912 Jung had begun to distance himself from Freud, not only in terms of theory and clinical practice, but also in terms of their personal relationship (Schröter, Michael, 1995).

The history of the secret committee took place in three phases: from 1912 to 1920, from 1920 to 1927, then from 1927 to 1936 (Wittenberger, Gerhard, 1995). Details about the committee’s first period—from its creation during the summer of 1912 until the Hague congress in 1920—are provided in five *Komiteebriefe* (committee letters), which do not yet present all the characteristics of the *Rundbriefe* (circular letters). These letters illustrate how, at this time, members of the committee discussed and jointly worked out the policies of the International Psychoanalytic Association (Wittenberger, 1996). The second phase covers the actual history of the institution. From this time, September 20, 1920, until March 14, 1926, there is an extensive correspondence of 361 circular letters.

The significance Freud gave to the creation of the secret committee and the importance of each of its members in the struggle for “the thing” (die Sache) held in common, is reflected in the symbol of the ring bearing a Greek inscription, which he offered to each of his colleagues as a sign of recognition and esteem. Those who were so honored wore the ring as a mark of their intimacy. The uncertainty about when the exchange of circular letters ended is an indication that the secret committee had been disbanded. This was the result of the dynamic of the group as well as the

relational dynamic between Otto Rank and Sigmund Freud and between Rank and his rival colleagues.

There is a break in the circular letters (April 1924 to November 1926) corresponding to the period between the gradual cessation of letter writing among the members, following Rank's break with Freud and his colleagues and ultimately from psychoanalysis, and the official renewal of correspondence. At the same time there was an increased exchange of private letters among the members of the secret committee and Freud, which had been noted by Ferenczi in a letter to Freud in March 1924. Because of the important role played by Rank during the peak years of the "international psychoanalytic movement" (Lieberman, E. James, 1985), his departure (end 1924–beginning 1925) and Abraham's death (December 1925), together with Freud's cancer (1923) all contributed to the destabilization and final breakup of the committee. It was only after the appearance of a circular letter, dated November 23, 1926, written by Anna Freud under her father's dictation, that a new agreement was reached to reintroduce the circular letters.

This initiated the third period of the former secret committee, which now functioned as the "central governing body of the International Psychoanalytic Association." Jones relates how "After the Innsbruck Congress (1927), we modified the structure of the committee by establishing our private group at the head of the International Psychoanalytic Association. Eitingon was named president, Ferenczi and myself, vice presidents, Anna Freud secretary, and van Ophuijsen treasurer" (1957). Hanns Sachs left the committee. The governing body resumed writing the circular letters. The eighty-three letters whose existence we are currently aware of provide a glimpse of the problems facing those who were forced to emigrate during the rise to power of National Socialism.

GERHARD WITTENBERGER

*See also:* International Psychoanalytical Association; "On the History of the Psychoanalytic Movement"; Psychoanalytic filiations.

### **Bibliography**

- Grosskurth, Phylliss. (1991). *The secret ring*. Toronto: McFarlane, Walter & Ross.
- Jones, Ernest. (1957). *Sigmund Freud: Life and work*. London: Hogarth Press.

Lieberman, E. James. (1985). *Acts of will: The life and work of Otto Rank*. New York: The Free Press.

Schröter, Michael. (1995). Freuds Komitee, 1912–1914: Ein Beitrag zum Verständnis psychoanalytischer Gruppenbildung. *Psyche*, 49, 513–563.

Wittenberger, Gerhard. (1995). *Das "Geheime Komitee" Sigmund Freuds. Institutionalisierungsprozesse in der psychoanalytischen Bewegung zwischen 1912 und 1927*. Tübingen: Diskord.

———. (1996). The circular letters (Rundbriefe), as a means of communication of the "secret committee" of Sigmund Freud. *International Forum of Psychoanalysis*, 5, 111–121.

---

## **SECRETS OF A SOUL**

A silent film about the talking cure which tells the story of the outbreak, psychoanalytic treatment, and cure of a knife phobia in a man, who has been living for some years in a happy but childless marriage. A murder next door and the return of his wife's cousin from abroad release in him a desire to murder his wife, which he does in a nightmare, but which a sudden inability to touch knives of any kind prevents him from carrying out in reality. Distressed to the point of suicide, he flees to his mother's house where he remembers a psychoanalyst, who had previously recognized his state of mind, and whose help he now seeks. During months of treatment, telescoped into three sessions of intense dream interpretation, the analyst takes the analysis through the presenting problem back to the original childhood trauma and forward into health via a cathartic abreaction as unconscious processes are made conscious.

Originally conceived as an educational film (Lehrfilm) with a booklet explaining the basic tenets of psychoanalysis in simple yet scientifically correct language, and based on an actual case history supplied by Karl Abraham and Hanns Sachs, the film developed into a full-length feature film with a cast of famous actors directed by Georg Wilhelm Pabst. Hailed as a masterpiece on its first showing in Berlin on March 24, 1926 it remains a milestone in the history of European cinema.

By contrast, it sparked off an intense controversy among psychoanalysts. Siegfried Bernfeld and Adolph Joseph Storfer used Vienna and the *Verlag* to publicly accuse their Berlin colleagues of bringing psychoanalysis into disrepute by presenting it in a facile and bowdlerized version and tried, unsuccessfully, to launch a

rival project of their own. Freud, who from the outset had expressed his doubts about the feasibility of the Berlin project, was supported in his opposition to the making of any psychoanalytic film by Max Eitingon, Sándor Ferenczi, and Ernest Jones.

The even-handed review printed in the *Internationale Zeitschrift für Psychoanalyse*—but not in the International Journal of Psychoanalysis—praised Abraham and Sachs for what they had achieved within the limitations imposed by the medium, and Sachs's booklet as a textbook on the essentials of psychoanalysis. But it also made the point that the resolution to psychic conflict as presented was similar to the cathartic abreaction as described by Freud in his first two American lectures, and concluded that the film did not represent psychoanalysis as a whole, but the quintessence of “psychoanalytic therapy.”

PAUL RIES

See also: Cinema criticism; Cinema and psychoanalysis; Germany; Sachs, Hanns.

### Source Citation

Pabst, Georg Wilhelm. (1926). *Geheimnisse einer Seele (Mysteries of a Soul)*. Newmann-film de Ufa-Kulturabteilung, Berlin.

### Bibliography

Fallend, Karl; and Reichmayr, Johannes. (1992). Psychoanalyse, Film und Öffentlichkeit : Konflikte hinter den Kulissen. In Fallend and Reichmayr, (Eds.): *Siegfried Bernfeld oder Grenzen der Psychoanalyse* Frankfurt am Main: Stroemfeld-Nexus.

Harnik, Jenö. (1927). Psychoanalytischer Film. *Internationale Zeitschrift für Psychoanalyse*, 13, 580–581.

Lacoste, Patrick. (1990). *L'Étrange Cas du Pr. M. Psychanalyse à l'écran*. Paris: Gallimard.

Ries, Paul. (1995). Popularise and/or be damned. Psychoanalysis and film at the crossroads in 1925, *International Journal of Psycho-Analysis*, 76, 759–792.

Sachs, Hanns. (1926). *Psychoanalyse. Rätsel des Unbewussten*. Berlin: Buchdruckerei Lichtbildbühne.

## SEDUCTION

The “scene of seduction” connotes attempts at seduction, real or fantasied, in the form of advances, incita-

tions, manipulations, or suggestions that are actively initiated by an adult vis-à-vis a child who is passive, even frightened.

The “theory of seduction” was a metapsychological model worked out by Sigmund Freud between 1895 and 1897 and then abandoned; it assigned an etiological role in the production of psychoneuroses to memories of actual seduction attempts. In 1893, bolstered by the accounts given him by his patients, Freud spoke of seduction as a clinical discovery. During the period 1895–1897, based on these clinical observations, he worked out a theory designed to explain the repression of infantile sexuality. On September 21, 1897, in a well-known letter to Wilhelm Fliess, he laid out his reasons for abandoning this model (1950a, pp. 259–260). This whole episode is eminently instructive from an epistemological as from a heuristic point of view, and is worth reviewing.

On May 30, 1893, Freud wrote to Fliess: “I believe I understand the anxiety neuroses of young people who must be regarded as virgins with no history of sexual abuse” (1950c, p. 73). This was his first allusion to the role of sexual seduction, still very broad in its application. In “Draft H,” dated January 24, 1895, he presented the following narrative: “He had called her up to the bed, and, when she unsuspectingly obeyed, put his penis in her hand. There had been no sequel to the scene, and soon afterwards the stranger had gone off. In the course of the next few years the sister who had had this experience fell ill. . . . I endeavored to cure her tendency to paranoia by trying to reinstate the memory of the scene. I failed in this. . . . She *wished* not to reminded of it and consequently intentionally repressed it. . . . She had probably really been excited by what she had seen and by its memory. . . . The judgment about her had been transposed outwards: people were saying what otherwise she would have said to herself” (1950a, pp. 207–209). Here then we have seduction, repression, and the foreshadowing of rejection, or what would much later be called foreclosure. On October 15, 1895, Freud wrote enthusiastically to Fliess: “Have I revealed the great clinical secret to you, either in writing or by word of mouth? Hysteria is the consequence of a presexual *sexual shock*. Obsessional neurosis is the consequence of a presexual *sexual pleasure* later transformed into guilt. ‘Presexual’ means before puberty, before the production of the sexual substance; the relevant events become effective only as *memories*” (1895c, p. 127). On May 30, 1896, he

distinguished the periods of life in which the event occurred from those in which repression came into play (1950a, pp. 229–231); and on May 2, 1897, with reference to fantasies in hysteria, he elaborated: “all their material is, of course, genuine. They are protective structures, sublimations of the facts, embellishments of them, and at the same time serve for self-exoneration. Their precipitating origin is perhaps from masturbation fantasies” (p. 247). The references to “structures,” “embellishments,” and “fantasies” indicate clearly that Freud was becoming increasingly dubious. In “Draft L,” an attachment to this last-cited letter, he went on: “The aim seems to be to arrive [back] at the primal scenes. In a few cases this is achieved directly, but in others only by a roundabout path, *via* phantasies. For phantasies are psychical façades constructed in order to bar the way to these memories. Phantasies at the same time serve the trend towards refining the memories, towards sublimating them” (p. 248). Truth to tell, the great revision was already under way.

In the famous letter to Fliess of September 21, 1897, Freud wrote: “I will confide in you at once the great secret that has been slowly dawning on me in the last few months. I no longer believe in my *neurotica*. This is probably not intelligible without an explanation. . . . Then came surprise at the fact that in every case the father, not excluding my own [a phrase long censored by successive editors of the Freud-Fliess papers], had to be blamed as a pervert . . . though such a widespread extent of perversity towards children is, after all, not very probable” (p. 259). Freud now realized that scenes of seduction could be the product of reconstructions in fantasy whose purpose was to conceal the child’s autoerotic activity. This was a historic moment in the shaping of psychoanalysis, rich in lessons about Freud’s creative functioning and typical of the tendency of his innovative thinking to be overtaken by its own development, often changing course when faced by contrary evidence but always anchored in clinical experience. Freud’s self-analysis, undertaken in the preceding months, following the death of his father, certainly made it possible for him to carry through this radical break, to approach the discovery of the Oedipus complex, and eventually to reject his seduction hypothesis as false. Much later, in 1924, he would write the following in a footnote to his “Further Remarks on the Neuro-Psychoses of Defence” (1896b): “At that time I was not yet able to distinguish

between my patients’ phantasies about their childhood years and their real recollections. As a result, I attributed to the aetiological factor of seduction a significance and universality which it did not possess. When this error had been overcome, it became possible to obtain an insight into the spontaneous manifestations of the sexuality of children which I described in my *Three Essays on the Theory of Sexuality* (1905d)” (p. 168n). A return to clinical observation was thus mandatory, and Freud had no theoretical alternative in the end but to assign seduction to the category of those primal fantasies whose origin he ascribed to the prehistory of humanity.

In the first Freudian clinical doctrine, the child at birth was naïve, innocent, and when confronted by the sexuality of the other perceived it as external, foreign, and strange: this was the context of the seduction theory; in Freud’s second clinical doctrine, the child was acknowledged to be the “polymorphously perverse,” inherent possessor of a primitive sexuality, destined to unfold in its interactions with its human surround. But while, historically speaking, infantile sexuality thus replaced seduction (scene and theory), it never obliterated it completely, and both clinical views continued to be discernible within psychoanalytic treatment, as Freud himself frequently pointed out from the *Three Essays* to the *Outline of Psycho-Analysis* (1940a [1938]).

HENRI SZTULMAN

*See also:* Amnesia; Character neurosis; Childhood; Deferred action; Fantasy; General theory of seduction; “Heredity and the Aetiology of the Neuroses; Memories; Mnemic symbol; Primal fantasies; Hysteria; Introjection; Libido; Narcissism; *Neurotica*; Seduction scenes; Trauma.

### **Bibliography**

- Freud, Sigmund. (1896b). Further remarks on the neuro-psychoses of defence. *SE*, 3: 157–185.
- . (1905d). Three essays on the theory of sexuality. *SE*, 7: 123–243.
- . (1925d [1924]). An autobiographical study. *SE*, 20: 1–74.
- . (1940a [1938]). An outline of psycho-analysis. *SE*, 23: 139–207.
- . (1950a [1887–1902]). Extracts from the Fliess papers. *SE*, 1: 173–280.

———. (1950c [1895]). Project for a scientific psychology. *SE*, 1: 281–387.

Le Goues, Gérard, and Roger Perron (Eds.). (1996). *Scènes originaires*. Monographs of the *Revue française de psychanalyse*. Paris: Presses Universitaires de France.

### Further Reading

Blum, Harold. (1996). Seduction trauma: representation, deferred action, pathogenic development. *Journal of the American Psychoanalytic Association*, 44, 1147–1164.

Eissler, Kurt R. (1993). Erroneous interpretations of Freud's seduction theory. *Journal of the American Psychoanalytic Association*, 41, 571–584.

## SEDUCTION SCENES

Seduction scenes are real or imaginary situations of a sexual character involving a child, whether as a spectator or forced participant. During the first period in his work, Freud placed under the rubric of “seduction scenes” both the child's observation of sexual relations between adults (generally the parents) and sexual advances made by an adult (often the father) or by an older child.

Freud early on had the idea of seeking the cause of the neuroses in traumas brought on by premature sexual experiences imposed on a child by an adult. In a letter to Wilhelm Fliess dated May 30, 1893, he reported having “analysed two such cases, and the cause was an apprehensive terror of sexuality, against the background of things [a child] had seen or heard and only half-understood; thus the aetiology was purely emotional, but still of a sexual nature” (1950c, p. 73).

This theme was central to Freud's contribution to *Studies on Hysteria* (1895d), written in collaboration with Josef Breuer. The case of Katharina reported there (pp. 125–134) is typical: Freud related the young woman's trouble to the fact that she has been a furtive witness to sexual relations between her elder sister and their father and then herself suffered similar assaults from him (in Freud's original account, the father was discreetly described as an uncle).

To begin with, Freud believed that such “seductions” were imposed upon children still in an asexual state. Their fright arose from incomprehensible scenes that they interpreted as violent and from their mystification by the adults' apparent excitement. The imma-

ture child thereafter retained a trace of an event whose traumatic character emerged only later, at puberty, when new events revived it.

Freud's initial misapprehension of childhood sexuality gave rise to two major psychoanalytic notions: the idea of the diphasic character of sexuality (the notion that psychosexual development occurred in two steps) and the idea of deferred action (according to which a mental event could derive its meaning and force from later events, by which it was reorganized retrospectively). From the outset, Freud faced the problem of how such a potential trauma could actually be deferred in this way. He first attempted to delineate an obscure “sexual-presexual” period (1950c, p. 127). He acknowledged that excitement and pleasure in response to a scene of seduction could exist in boys, if not in girls. Boys, he argued, being more active, tended toward obsessional neurosis, whereas girls, who experienced such scenes passively, were more likely fated to relive them in a hysterical mode (1950a, pp. 223–224, 228). The unsatisfactory nature of such attempted solutions led Freud, in his *Three Essays on the Theory of Sexuality* (1905d), unequivocally to accept the role of infantile sexuality.

A correlated major revision is foreshadowed in Freud's letter to Wilhelm Fliess of September 21, 1897. There he conceded that the scenes of “seduction” by the father that his hysterics recounted probably related “in every case” not to real events but to fantasies (1950a, p. 259). Although this startled Freud at first, he made a swift recovery, as he later recounted in vivid terms in his *Autobiographical Study* (1925d [1924]). The psychic implications of fantasies were much more important than the real event, he there claimed, and fantasies could be nourished by apparently banal or minor incidents (for example, the copulation of animals might be related in the child's imagination to sexual activity between the parents).

Freud never disavowed his theory of trauma, but in his second period, in which he focused his attention on the “primal scene” (the real or fantasized observation of sexual relations between the parents), he returned again and again to the issue of the relationship between “psychic” and “historical” (event-governed) reality. In his account of the “Wolf Man” case (1918b [1914]), the following question forms a veritable leitmotif: did the eighteen-month-old child really see his parents engaged in *coitus a tergo* (vaginal penetration from behind), with the trauma making its appearance by way of a dream



only when he was four, or was the entire scene merely a “product of the imagination” (p. 49)? Freud was thus led to postulate that primal scenes, bequeathed to every individual by the history of humanity itself, helped form the psychic apparatus (1912–1913a).

Sándor Ferenczi (1955), who fully acknowledged the role of childhood sexuality, emphasized the traumatic character not of the seduction itself but rather of the frustration that the child dramatically experiences when an adult, in the wake of exciting solicitations, disappoints the child by a rejection that points up the child’s powerlessness. This is perhaps inevitable if, as Freud himself emphasized, the mother, as the earliest caregiver, is, by force of circumstance, the first seductress (psychoanalytically conceived). Along similar lines, Jean Laplanche has made his “general theory of seduction” the centerpiece of his *New Foundations for Psychoanalysis* (1989).

ROGER PERRON

*See also:* “Confusion of Tongues between Adults and the Child”; Deferred action; “From the History of an Infantile Neurosis (Wolf Man)”; General theory of seduction; Katharina, case of; Seduction; Sexual trauma.

### Bibliography

- Ferenczi, Sándor. (1955). Confusion of tongues between adults and the child. In his *Final contributions to the problems and methods of psycho-analysis*. London: Hogarth Press and the Institute of Psycho-Analysis. (Original work published 1933)
- Freud, Sigmund. (1905d). Three essays on the theory of sexuality. *SE*, 7: 123–243.
- . (1912–1913a). Totem and taboo. *SE*, 13: 1–161.
- . (1918b [1914]). From the history of an infantile neurosis. *SE*, 17: 1–122.
- . (1925d [1924]). An autobiographical study. *SE*, 20: 1–74.
- . (1950a [1887–1902]). Extracts from the Fliess papers. *SE*, 1: 173–280.
- . (1950c [1895]). *The origins of psycho-analysis: Letters to Wilhelm Fliess, drafts and notes, 1887–1902* (Eric Mosbacher and James Strachey, Trans.). London: Imago, 1954.
- . (1895d). Studies on hysteria. *SE*, 2: 48–106.
- Laplanche, Jean. (1989). *New foundations for psychoanalysis* (David Macey, Trans.). Oxford: Blackwell. (Original work published 1987)

### SELECTED FACT

The expression “selected fact” was borrowed by Wilfred R. Bion from the French mathematician Henri Poincaré to refer to the element that makes it possible to give coherence to a group of scattered data.

In *Science and Method* (1908), Poincaré considered the “selection of facts” that enabled science to discover laws of general validity—that is, facts that introduce order and coherence into the complexity of the world. Bion, elaborating his ideas in “A Theory of Thinking” (1962), initially placed emphasis on the container-contained relationship, taking as his paradigm the mother-infant dyad: The baby projects unassimilable “bad” elements of its own psyche onto the maternal psyche, and the mother bears the responsibility of restituting this material to the baby in a form that is psychically assimilable. Bion denotes this relationship using the conventional female and male symbols: ♀ ♂.

Bion later became interested in the process by which the mind transforms a chaotic, persecutory experience into an experience that is integrated, representable, and thinkable. This corresponds to the passage from what Melanie Klein calls the schizoid-paranoid position, in which the elements of the psyche are split and projected, and thus dispersed, to what she calls the depressive position, where these elements can come together and become stabilized in a stable configuration. Bion proposes the equation PS [ $\leftrightarrow$ ] D, where PS represents the schizoid-paranoid position and D represents the depressive position. The selected fact is the element that allows for passage from the first position to the second; it serves as a starting point for interpretation by the psychoanalyst, who becomes aware that a multitude of aspects of the patient’s material come together and make sense, beginning with a given element of the transference.

Although he borrows the notion of the selected fact from scientific methodology, Bion establishes an essential difference between the scientific approach that seeks the laws of nature and the psychoanalyst exploring the psychic reality of their patient. The scientist is searching for logical connections among the objective data collected, whereas the psychoanalyst is interested in the emotional links that seem both to dominate the transference relationship and to create interconnections among the disparate elements of associative material: “Selected fact is the name for an emotional experience, the emotional experience that

consists in discovering coherence; its meaning is thus epistemological, and the relation among selected facts must not be considered logical," writes Bion in "A Theory of Thinking."

DIDER HOUZEL

See also: Bion, Wilfred Ruprecht

### **Bibliography**

- Bion, Wilfred Ruprecht. (1962). A theory of thinking. *International Journal of Psycho-Analysis*, 63, 4–5. Reprinted in *Second thoughts*. London, Heinemann: 1967.
- Grinberg, Léon, Sor, Dario, and Tabak de Bianchedi, Elizabeth. (1991). *New introduction to the work of Bion*. Northvale, NJ, and London: Jason Aronson.
- Symington, Joan, and Symington, Neville. (1996). *The clinical thinking of Wilfred Bion*. London: Routledge.

---

## **SELF**

The term *self* is used in several different senses. It can refer to the ensemble of the psychic agencies, the narcissistic organization of the psyche, or the conscious part of the psyche that enables the individual to recognize himself or herself as an agent and a subject endowed with reflexive consciousness.

The German *Selbst* is sometimes encountered in Freud's writings to refer to the person. Beginning in the 1940s, Melanie Klein used the word *self* in the general sense of representation of the inner world. We can attribute the first psychoanalytic usage of the term to Heinz Hartmann, who in 1950 used it to refer to the ensemble of the psychic agencies, all of them being the object of the narcissistic drive.

The concept of self was partly included in the term *Ich* ("I"), in the sense that Freud used it until 1920. *Ich* was both the person in his or her totality and subjectivity, and the organizing portion of the psyche. From the time of the second topography, the ego became a specific structure. To avoid ambiguity, some English-speaking psychoanalysts began to use the word *self*, already in use in philosophy and social psychology (William James, George Herbert Mead, Gordon William Allport), to refer to the whole person.

The term *self* evolved in three different directions. During the 1950s it was used with similar meanings by the two British schools. In "Our Adult World and Its

Roots in Infancy" (1959), Melanie Klein proposed this definition of it: "The self is used to cover the whole of the personality, which includes not only the ego but the instinctual life which Freud called the id" (p. 249). Anna Freud also used it to refer to the totality of the psyche, but preferred to use it in reference to the self understood as the object of narcissistic investment.

In the theories of Heinz Kohut, the self is no longer the object of narcissistic libido but instead an organizing structure of the mind. In his "generalized" conception (1978), the self is a "superordered" center, constructed outside of the action of the drives through the relationship with the self objects. The self objects (ideal, mirroring, or alter ego), which are manifested by the corresponding narcissistic transferences, create the major components of the self: the pole of ideals, the pole of ambitions, and the pole of knowledge (1984). The cohesion of the self, which depends on the empathy of the self-objects, determines the capacity to overcome the conflicts linked to the drives. The self is a structure, but Kohut also often alluded to self-representation and self-consciousness.

The mind's reflexive function was not particularly explored by psychoanalysis, although in *The Interpretation of Dreams* (1900) Freud defined consciousness as "a sense organ for the perception of psychological qualities" (p. 615). Edith Jacobson described the self as the source of internal subjective reality and referred to the representations of self that are manifested in analysis (1964). Donald Winnicott (1961) considered this subjective perspective obvious. He attributed to the self the feeling of the reality, continuity, and rhythm of mental life, at the same time emphasizing that it is rooted in bodily sensations. In "Ego Distortion in Terms of True and False Self" (1960), he contrasted the true self, whose positive aim is "the preservation of the individual in spite of abnormal environmental conditions" (p. 143), to the false self, which is constructed in conformity to parental expectations and throughout life takes on the role of protecting the true self.

Formation of the self is an aspect of psychic development, whether in terms of an epigenetic conception of development (Erik Erikson, Heinz Lichtenstein), a psychic skin (Esther Bick, Didier Anzieu), or precursors to the self (Daniel N. Stern). Kohut's followers proposed an intersubjective theory of the analytic process that attributes a structuring role to the self's reflexivity (Robert D. Stolorow, George E. Atwood,

Bernard Brandschaft). A similar orientation is found in the work of Thomas Ogden, a post-Kleinian who developed the notion of the “analytic object” (André Green) in a theory of a third, subjective space, the locus of the relationship between patient and analyst.

The use of *self* in a specific sense is often criticized for potentially depriving the word *ego* of the richness of its multiple meanings. Yet clearly, this concept has been instrumental in the formation of several important developments in psychoanalysis. However, owing to the very breadth of the term *self*, it only has a heuristic value if the sense in which it is being used is specified.

MAURICE DESPINOY AND MONIQUE PIÑOL-DOURIEZ

*See also:* Autism; Ego; Ego psychology; Fragmentation; Heroic self, the; Identity; Narcissism; Principle of identity preservation; Self (analytical psychology); Self psychology; Self (true/false); Symbolic equation.

### **Bibliography**

- Hartmann, Heinz. (1950). Comments on the psychoanalytic theory of the ego. *Psychoanalytic Study of the Child*, 7, 9–30.
- Klein, Melanie. (1959). Our adult world and its roots in infancy. In *Envy and Gratitude and Other Works 1946–1963*. London: Hogarth, 1975.
- Kohut, Heinz. (1977). *The restoration of the self*. New York: International Universities Press.
- Ogden, Thomas. (1994). *Subjects of analysis*. London: Karnac Books.
- Winnicott, Donald W. (1960). Ego distortion in terms of true and false self. In *The Maturational Processes and the Facilitating Environment*. London: Hogarth and Institute for Psycho-Analysis, 1965.

## **SELF-ANALYSIS**

Self-analysis consists of interpreting one’s own preconscious and unconscious material (such as dreams, parapraxes, memories, fleeting thoughts, and intense emotions).

Psychoanalysis is to a great extent a result of Freud’s self-analysis between 1895 and 1902. The analysis of his own dreams brought him confirmation of what he found in the dreams of his patients and, reciprocally, he better understood their dreams on the basis of his own. Freud’s self-analysis only became systematic after

the death of his father in October 1896, and that it complemented and sustained his project of writing a book on the interpretation of dreams.

The method of self-analysis developed by Freud included four steps: writing down the material obtained; breaking it up into sequences; free associating on each of the sequences; and finally, forging links based on the associations produced, these links thus taking on an interpretive significance.

In his first conception of psychoanalytic training, Freud assumed that what was needed was a preliminary experience of self-analysis based on his model. Later, he took the position that the experience of a personal analysis should be required of future analysts. The risk of self-analysis is that it favors narcissistic self-satisfaction or obsessional rumination. Self-analysis could never be a purely solitary mental activity: Freud developed it in the course of a scientific, emotional, and fantasy exchange with his friend Wilhelm Fliess from Berlin. An active self-analysis takes place within the context of interrelations (with family or patients, for example). Furthermore it presupposes a subjective commitment to remain in analysis despite the development of personal crises.

Self-analysis can be fruitful if it prolongs the psychoanalytic work of which it is an echo. The main difficulty is the neglect of transference/countertransference relationships. One solution to this problem might be an introjection of the image of the analyst as an ideal object with whom an interior dialogue may then be pursued. This is probably what occurred in the case of Samuel Beckett after the interruption of his analysis with Wilfred Bion. His subsequent novels *Mercier and Camier*, *Molloy*, *Malone Dies*, and *The Unnamable* may thus constitute fictional sessions with a fictional analyst.

DIDIER ANZIEU

*See also:* “Disturbance of Memory on the Acropolis, A”; *Freud’s Self-Analysis*; *Interpretation of Dreams, The*; Introjection; Jung, Carl Gustav.

### **Bibliography**

- Anzieu, Didier. (1986). *Freud’s self-analysis* (Peter Graham, Trans.). Madison, CT: International Universities Press. (Original work published 1975)
- Barron, James W., et al. (1993). *Self-analysis*. Hillsdale, NJ, and London: The Analytic Press.

## SELF-CONSCIOUSNESS

Self-consciousness is the mental activity through which the subject feels a sense of being or existing as a unique and total individual. Although it does not obviate the idea of the unconscious, this notion comes out of reflexive philosophy and its derivatives that hold that the human faculty of consciousness, apparent to itself and having itself as its object, marks the primacy of consciousness in the definition of the human psyche. This sense of identity, this initial subjective stance, is established gradually, being linked with the general development of the human mind in its relationship to itself and the outside world.

This notion has taken on different forms throughout intellectual history, beginning with René Descartes's insistence on the primacy of consciousness in the human mind. In the nineteenth century, after Georg Wilhelm Friedrich Hegel's work but before that of Edmund Husserl, Franz von Brentano posited self-consciousness as being secondary to consciousness or intentionality toward the object. Husserl inverted that order, positing a reflective unit that is the mental locus of the relationship between subject and world, a pronominal form in which the subject, through discourse, identifies with what it believes it is or would like to be. This internal perception is also linked to the specular image of the body.

Finally, this notion is found in the work of Ludovic Dugas, a late-nineteenth-century semiologist. Drawing from the work of Hippolyte Taine and Théodule Ribot, Dugas approached the idea of self-consciousness from a negative perspective by looking at its dysfunction: "state[s] in which the subject feels estranged from his being and from things and begins to doubt that all that he is feeling is real." Such states entail alienation and the ego's inner loss of meaning—a loss of the immediate grasp of the ego's own inner states and the sense of existing. This sense of self-estrangement when the subject, in a state of indifference, feels his acts and emotions eluding him, is called *depersonalization* or *loss of self-consciousness*.

The idea of mental activity that supposedly situates the individual as being self-present and in an unmediated state in relation to himself, first attacked by Friedrich Nietzsche, was to be further diminished by Sigmund Freud and psychoanalysis. Jacques Lacan showed how Freud's discoveries decentered the subject

from the self-consciousness heretofore upheld by Hegelian philosophy and the solipsism of the Cartesian cogito. In "The Mirror Stage As Formative of the *I* Function" (1949/2002), Lacan describes the conditions for the appearance of self-consciousness: the moment when the infant, first in its mother's arms and later, once the baby is physically able, by itself, can "already recognize his own image as such in a mirror. This recognition is indicated by the illuminative mimicry of the *Aha-Erlebnis*" (p. 3). This jubilatory assumption on the part of the infant situates the ego and the recognition of the bodily imago within the necessary mediation of the gaze and the desire of the other, initially represented by the mother. Without letting himself be caught up within the fiction of this movement, Lacan emphasizes "the imaginary capture of the self through specular reflection within the function of misrecognition [*méconnaissance*] that remains attached to it" since alienation is the fact of the subject who is not "a being conscious of itself." Jean Laplanche later called this mental activity the "capability or incapability of consciousness."

Child psychoanalysis (Donald Winnicott, Serge Lebovici, and Michel Soulé) defines the child's sense of existing within the movement of his or her constitution of an inner universe, a container that makes possible relations with the self and the outside world. This container is elaborated gradually beginning with the child's experience with the mother, which is never totalizing, and it keeps the subject from being absent from itself. The child's rudimentary ego, after a period where there is no distinction between it and the world, creates a boundary where the *I* and the not-*I* are distinguishable, just as the image of the body takes on wholeness.

Didier Anzieu emphasizes in *The Skin-Ego* (1985) that "all mental function, in its development, is supported by a bodily function whose workings it transposes onto the mental plane." This implies that all ego feeling is both mental and corporeal. Involved here are the subject's sense of continuity in time, of proximity to self, of causality (the *I*), and of boundaries of which the subject is not always conscious, but which are revealed when normal mechanisms fail (depersonalization and certain states of mystical ecstasy). Carl Gustav Jung, although he prefers to speak in terms of "ego-consciousness," also links this mental activity to the child's progressive individual differentiation. If the mother is the condition for the appearance of ego-

consciousness, she is also that from which the child must distinguish itself. The process of individuation becomes merged with self-consciousness and “affect enables us to experience consciousness of ourselves with greater acuity and intensity.” Finally, in Freud’s work the notion of self-consciousness is not often used. In *The Interpretation of Dreams* (1900) he emphasizes that self-consciousness is suspended in dreams. In “On Narcissism: An Introduction” (1914) he links it to, on the one hand, moral consciousness, which serves philosophical introspection, and, on the other, to the self-perception that nourishes self-esteem. In “Group Psychology and the Analysis of the Ego” (1921) this sense of continuity that the individual acquires through his traditions, habits, and sphere of activity, this conscious personality, this “voice of consciousness” will be overtaken by the force of suggestion and hypnosis or, alternatively, will be deemed to be temporarily lost to the individual “following his absorption into the crowd.”

Expanded knowledge about children, neurology, and the study of failures of self-consciousness can provide a better approach. It should also be noted that the distinctions between the self (in the various usages of that term) and the ego can help to establish with precision their locus and movement.

Overall, the notion of self-consciousness remains marked by its philosophical origins. There can be no complete assurance of its consistency within psychoanalysis.

MARIE CLAIRE LANCTÔT BÉLANGER

*See also:* Alienation; Alpha-elements; Brentano, Franz von; Depersonalization; Ego feeling; I; Identity; Infant development; Mirror stage; Phenomenology and psychoanalysis; Schilder, Paul Ferdinand; Self-image; Self-representation.

### **Bibliography**

- Anzieu, Didier. (1989). *The skin ego*. New Haven and London: Yale University Press. (Original work published 1985)
- Dugas, Ludovic. (1898). Observations et documents: Un cas de dépersonnalisation. *Revue philosophique*, 14, 500–507.
- Freud, Sigmund. (1921). Group psychology and the analysis of the ego. *SE*, 18: 65–143.
- Lacan, Jacques. (2002). The mirror stage as formative of the I function. In *Écrits: A selection* (Bruce Fink, Trans.). New York: W. W. Norton. (Original work published 1949)

## **SELF-ESTEEM**

Esteem for the self consolidates the sense of one’s own value or, more mundanely, one’s pride. Hence Freud’s interest in it in “On Narcissism” (1914c): “One part of self-regard is primary—the residue of infantile narcissism; another part arises out of the omnipotence which is corroborated by experience (the fulfillment of the ego ideal), whilst a third part proceeds from the satisfaction of object-libido” (p. 100). As the effect of ego demands on the “narcissistic” ego ideal and “moral conscience,” the feeling of self-esteem is at the origin of repression: “In paraphrenics self-regard is increased, while in the transference neuroses it is diminished” (p. 98). It is nevertheless the narcissistic part that proves to be determinant: when self-esteem is threatened, the result is shame rather than guilt. It therefore depends, in each individual life and in the different psychopathological cases, on the quality of the subject’s narcissism and thus on the modalities of the subject’s cathexis by and of the object, as it depends for its regulation on its relations with the ego ideal (Janine Chasseguet-Smirgel). All situations of existential crisis shatter it particularly, adolescence being an example, but especially melancholy because, according to Freud (1916–17g), what differentiates it from “normal mourning,” over and above the common loss of object that characterizes them both, is the fact that it calls itself into question.

RAYMOND CAHN

*See also:* Ego ideal; Inferiority, feeling of; “Mourning and melancholia”; Omnipotence of thought; “On Narcissism: An Introduction”; Self-consciousness; Self, the; Suicide.

### **Bibliography**

- Chasseguet-Smirgel, Janine. (1973). Essai sur l’Idéal du Moi. Contribution à l’état psychanalytique de “la maladie d’idéa-lité.” *Revue française psychanalyse*, 37 (5–6), 735–929.
- Freud, Sigmund. (1914c). On narcissism: An introduction. *SE*, 14: 67–102.
- . (1916–17g). Mourning and melancholia. *SE*, 14: 237–258.

## **SELF-HATRED**

Self-hatred is a reflexive notion: In it, the subject is the hating person and at the same time the hated person.

The concept of self-hatred appeared in Sigmund Freud's "Mourning and Melancholia" (1916–17a [1915–17]): "If the love for the object . . . takes refuge in narcissistic identification, then the hate comes into operation on this substitutive object" (p. 251).

This concept was thus initially understood as the vicissitude of identification with the object of loss: "The self-tormenting in melancholia . . . signifies . . . a satisfaction of trends of sadism and hate which relate to an object, and which have been turned round upon the subject's own self" (p. 251). Later, in "The Ego and the Id" (1923), it was developed in connection with obsessional neurosis and melancholia, but this time within the framework of the second topography. At this point, the superego was theorized as replacing the object that persecutes the ego: "The fear of death in melancholia admits of one explanation: that the ego gives itself up because it feels itself hated and persecuted by the super-ego, instead of being loved" (p. 58). Revealed here is the degree to which self-hatred is infiltrated by sadomasochism, and to which the superego, in this context, can become the "culture of the death instinct" (1923b, p. 53).

In *Language and Insight* (1978), Roy Schafer emphasized the idea that the persecutor and the victim can unconsciously be persons other than the self, "say, one's father in the act of hating one's mother; here, 'I hate myself' translates into 'In this way I enact, experience, and perpetuate my father's hating my mother'" (pp. 123–124). In (1990), André Green introduced the interesting idea of the logic of despair, in which self-hatred is posited as reflecting "a compromise between the inextinguishable desire for revenge and concern for protecting the object from the hostile desires directed against it."

NICOLE JEAMMET

*See also:* Turning around upon the subject's own self.

### **Bibliography**

Freud, Sigmund. (1916–17a [1915–17]). Mourning and melancholia. *SE*, 14: 237–258.

———. (1923b). The ego and the id. *SE*, 19: 1–66.

Schafer, Roy. (1978). *Language and insight*. New Haven: Yale University Press.

---

## **SELF-IMAGE**

The term *self-image* has entered common usage. Initially referred to by psychologists, it was then taken up

by psychoanalysts without really being theorized. The self-image is ostensibly the representation that everyone has of themselves, in physical as well as physiological, sociological, and mental terms, envisioned through the prism of each individual self-evaluation at different stages of development and in different situations.

Formerly, this notion was often considered to be the equivalent of the body scheme, postural scheme, somatopsyché, image of body-ego, or even somatognosia, although each of these notions had its own characteristics in terms of both its limits and its basic conception. Within this current of thought, the self-image can be seen as the representation of one's own body, as both body-object within one's environment and body in relation to others; or as the totality of a body that is initially experienced as being fragmented; or, finally, as a body that is experienced as autonomous, upon emergence from the period of non-differentiation.

When used in psychoanalysis, the self-image brings together the notions of body image, self-consciousness, the concept of the self, self-identity, and ego-identity. Self-image is constructed through imitations of (for psychology), or identifications with (in psychoanalysis), people around the subject or real or heroic imaginary figures, throughout the development of narcissism and the setting up of the ideal ego, the ego ideal, and the superego. The self-image is dependent as well upon the type of object relations established.

The notion of the self-image emerged in and was refined through the work of a number of authors, in particular that of Henri Wallon, who described the emergence, during the fifth stage of development (personalism), of self-awareness, which can only occur if the child is capable of having a self-image. This ability is related to the test in which the child recognizes itself in a mirror, whereas previously it had mistaken its specular image for another person. Heinz Hartmann, founder of the ego psychology movement, introduced the distinction between the ego, as psychic agency, and the self, in the sense of the person or personality proper. Paul Schilder posited that the formation of body image plays a determining role in the genesis of the representation of self that follows organization of the ego and the evolution of narcissism. In the view of Donald Winnicott, the mother and the primary mothering environment mirror (or do not mirror) back to the child an image of itself with which the child can (or cannot) identify. In this view, the self is

an agency of the personality in the narcissistic sense, a representation of self for the self, a libidinal investment of self. Heinz Kohut, in self-psychology theory, proposed the self as a notion that relates to the personality in its entirety, to psychic functioning as a whole, to the bodily self, as well as to more clearly defined elements such as self-representation. Jacques Lacan returned to the “mirror stage” to show that the young child’s recognition of its own specular image founds the dual relation, the dimension of the imaginary, and the ideal ego. In the view of Françoise Dolto, body image plays a part in the subject’s identification and determines the possibility of a feeling of self—of self within a body. Here, the body is the basis for the construction of the subject’s identity in relation to others, and the unconscious image of the body is the forgotten (repressed) bodily foundation for the feeling of self.

It is important, too, to make clear that the self-image also depends on how others see and assess us. We should perhaps add to the notion of the self-image the feeling of competence that is the cognitive construction corresponding to the opinion that each of us is subject to on the cognitive, social, and physical levels, and the relational feeling of self-esteem.

PHILIPPINE MEFFRE

See also: Body image.

### **Bibliography**

Ajuriaguerra, Julian de. (c1980). *Handbook of child psychiatry and psychology*. (Raymond P. Lorion, Ed.) New York: Masson. (Original work published 1970)

Dolto, Françoise. (1997). *Sentiment de soi, aux sources de l'image du corps*. Paris: Gallimard.

Oppenheimer, Agnès. (1998). *Heinz Kohut*. Paris: Presses Universitaires de France.

## **SELF-MUTILATION IN CHILDREN**

In psychiatric usage the term “self-mutilation” (auto-mutilation), a combination of the Greek root *autos* (self) and the Latin verb *mutilare* (mutilate), refers to behavioral forms characterized by acts of physical injury initiated by the subject; such acts are subject to various interpretations. Some authors have suggested the use of the expression “unintentionally self-inflicted injury,” which avoids the assumption of intentionality (Carraz, Yves, and Ehrhardt, Raymond, 1973).

The term “self-mutilation” was first used to describe physical injuries that schizophrenic patients or those suffering from melancholia sometimes inflicted on themselves. These were frequently directed at the genital organs, but the hands and eyes were also affected, especially in schizoid patients experiencing a period of mystical delirium. Karl A. Menninger in 1935 wrote a psychoanalytic study on the question. Menninger considered these signs of self-mutilation to be acts of self-punishment, which symbolized castration.

Self-mutilation has also been described in other psychopathological contexts: in relation to masochistic compulsions or within the context of some perversion; such behavior has also been described during states of heightened or chronic anxiety.

A particular and relatively frequent aspect is represented by the repetitive scarification or carving resorted to by some adolescents. The meaning of such behavior is difficult to interpret, especially since the subjects themselves do not associate any mental imagery with it. Aside from serving as a discharge designed to temporarily eliminate psychic suffering and short-circuit the activity of thought (Delarai-Chabaux, Catherine, and Roche, Jean-François, 1996) common to the majority of such behavior, this type of self-mutilation involves questions about the psychic status of the body in the adolescent.

In the infant, self-mutilation is observed in children who are severely mentally retarded or autistic, and especially when both types of pathological organization are combined. The most severe forms occur in children who cannot speak. In this clinical context, several authors have attempted to identify the different psychopathological interpretations of self-mutilation. Salem A. Shentoub and André Soulairac refer to motor discharges, possibly “self-offensive,” that can arise during normal development, especially between the ages of twelve and eighteen months, during the activity of sensory-motor exploration, although these have no pathological value. This primitive self-mutilation decreases rapidly with the development of the bodily schema and the differentiation between ego and not-ego. The infant perceives the causality of the pain; aggressive behavior towards others may then appear. In infantile psychoses self-mutilation is associated with the inability to modulate relational distance and the failure of defense mechanisms, which leads to a massive regression to undifferentiated stages of psychic

organization, where the ego is confused with the non-ego.

F. Dumesnil attempted to differentiate self-mutilating behavior in different forms of autism and infantile psychosis. Referring to the work of Frances Tustin and Margaret Mahler, he distinguished between “internal shell autism,” “external shell autism,” the “regressive autistic position,” “symbiotic psychosis,” and “moderate retardation.” In internal shell autism, self-mutilation appears to be a ritualized self-injurious gesture intended more for protection than destruction, in which the mutilatory aspects appear to be accidental. In external shell autism, self-mutilation, which is less mechanical but more violent than in the previous group, can be considered a self-destructive gesture without any specific intentionality. According to Dumesnil, its appearance is determined by an “experience of conflict” and must be understood as “the acting out of an intensely difficult emotion,” probably of a depressive nature. In the regressive autistic position, self-mutilation corresponds to a “discharge of hostility and anxiety” that occurs in connection with an anxiety-causing situation of internal or external origin, and which can be directed, in an undifferentiated manner, towards others or the self, because of the absence of a defined bodily limit. In symbiotic psychoses, where the mechanisms of splitting are prevalent, self-mutilation appears in situations where hostility gives rise to an “intense discharge of hatred.” Again, according to Dumesnil, these violent acts of self-mutilation, which specifically affect certain parts of the body, involve “an interplay of introjections and projections enabling the person to actualize the bad object within himself” and to maintain the feeling that the outside is completely good. Finally, in moderate retardation, self-mutilation results in a relatively disorganized discharge of anger triggered by some kind of frustration; it does not appear to be “directed” toward an object.

Some self-injurious behavior observed in cases of autism or mental retardation seems to fall within the framework of the auto-sensory phenomena described by Frances Tustin. These serve to maintain the child in a “constant bath of stimuli” that helps to form a “psychic skin” (Esther Bick), protecting the child from environmental discontinuities. The attempt to damage corporal integrity here appears to be an unintentional consequence of self-stimulation. The physiological phenomenon of habituation likely contributes to their

gradual intensification. In other cases, the deliberate search for a more or less violent contact with hard objects evokes what Tustin has described as an “autistic object.” The sensation of hardness serves to ensure a corporal limit while avoiding separation from the nipple. The distinction observed in clinical psychoanalytic work between the repetitive search for experiences of pure stimulation—which are aimed, well below the threshold of autoeroticism, at “feeling that one exists”—and a very real self-destruction can be compared with the opposition between life narcissism and death narcissism introduced by André Green.

Self-mutilating behavior can also occur when relations involve a form of partial object cathexis, which gives rise to attempts at omnipotent control of the object; separation then leads to violent displays directed toward another or toward the infant himself. The intentionality of self-mutilating behavior appears more clearly here since it reflects a form of aggression turned against the self, as a response to frustration, or because it represents an appeal or request, possibly reinforced by the responses provided by those in the subject’s immediate environment.

On another level self-mutilation raises the question of pain and its perception in the autistic child. Is there an elevation in the threshold of pain perception in these infants, as some neurobiological theories claim (endorphins)? Or is this apparent insensitivity the expression of an “intractable interweaving of pleasure and pain,” leaving the observer with the impression of a “desperate pleasure” (Jean Ochonisky)?

There also exist a number of forms of rhythmic behavior, most notably head banging, which can result in lesions of varying severity. It is known that these symptoms are particularly frequent in situations of separation or emotional deprivation. It can be hypothesized that for the infant rocking plays the role of maternal holding, or that the self-mutilation is a substitute, in the body of the child, for the missing object.

These attempts at psychopathological understanding are important for ensuring proper institutional care of such pathologies. Self-mutilating behavior arouses strong feelings of powerlessness and guilt, and sometimes even depression, in caregivers as well as parents.

CLAUDE BURSZSTEJN

*See also:* Autism; Infantile psychosis; Suicide.



### Bibliography

- Carraz, Yves, and Ehrhardt, Raymond. (1973). L'automutilation chez des enfants en institution. *Revue de neuropsychiatrie infantile*, 21, 217–227.
- Delarai-Chabaux, Catherine, and Roche, Jean-François. (1996). Les coupures cutanées à l'adolescence: le carving. Sens et fonction du symptôme. *Neuropsychiatrie de l'enfance et de l'adolescence*, 44, 43–48.
- Dumesnil, F. (1984). Analyse différentielle de cinq pathologies précoces et des automutilations qui en découlent. *Neuropsychiatrie de l'enfance et de l'adolescence*, 32, 183–195.
- Ochonisky, Jean. (1984). L'automutilation a-t-elle un sens? *Neuropsychiatrie de l'enfance et de l'adolescence*, 32, 171–181.
- Shentoub, Salem A., and Soulairac, André. (1961). L'enfant automutilateur. *Psychiatrie de l'enfant*, 3, 111–145.

### Further Reading

- Fowler, C., and Hilsenroth, M. (1999). Some reflections on self-mutilation. *Psychoanalytic Review*, 86, 721–732.
- Fowler, J.C., et al. (2000). The inner world of self-mutilating borderline patients. *Bulletin of the Menninger Clinic*, 64, 365–385.

## SELF-OBJECT

The term *self-object* refers to any narcissistic experience in which the other is in the service of the self, the latter being defined as a structure that accounts for the experience of continuity, coherence, and well-being. It is a source of narcissistic feeling.

The notion of selfobject appeared in the work of Heinz Kohut as early as his 1968 article, “The Psychoanalytic Treatment of Narcissistic Personality Disorders,” in his discussion of the narcissistic transference, in which the analyst is an archaic selfobject function in the narcissistic pathology. It was further developed in *The Analysis of the Self* (1971) in Kohut's reconceptualization of narcissism. It refers to a normal narcissistic function that evolves in stages. The selfobject can be the object of a fixation that is the basis for a narcissistic transference. When the object is narcissistically invested, the narcissistic object relation is opposed to object-love.

The hyphen (*self-object*) disappeared in *The Restoration of the Self* (1977), because the selfobject is

not reducible to the archaic configurations of narcissism, but is rather defined as a dimension of experience. In 1979, Kohut generalized a selfobject that is inseparable from the self, of which it is the existential correlate and the source. At the beginning, Kohut reminded us in his 1980 article, “Selected Problems of Self Psychological Theory,” the descriptor *selfobject* was reserved for pathology in the sense of an archaic fixation, with the emphasis being placed on the grandiose self or the omnipotent selfobject. Like the object, the selfobject is at first replaceable, before becoming meaningful. In the mature self/selfobject relationship, the archaic selfobjects continue to exist at a deep level and to resonate as leitmotifs at various times.

In *How Does Analysis Cure?* (1984), the selfobject became a dimension of experiencing another person whose functions are related to the self. The selfobject can thus be archaic or mature, anachronistic or appropriate. A support for the vulnerable self, it is the appropriate medium of the healthy self, like the oxygen that is necessary for life. The self is a feeling of unity, strength, and harmony if, at each stage of life, it receives the appropriate responses from the selfobject environment: availability and receptivity, the conditions for all mental life. The selfobject is an intrapsychic experience. In times of temporary vulnerability, the better equipped the subject is to find the selfobjects he or she needs, the healthier he or she will be. The selfobject is not necessarily a person; it can be music, an outing, a talent, culture, and so forth.

It is often difficult to distinguish between that which comes from the object and that which comes from the selfobject, especially in adults. In pathologies or in the context of treatment, the distinction is easier to make. The object is recognizable through representation and comes from desire. The selfobject is an archaic or mature function that comes from need. If the other is the target of desire, anger, love, or aggression, that other is an object. If the other maintains cohesion, strength, and personal harmony, it is a self-object. Object-loss results in mourning; the relationship to the selfobject cannot be lost but can instead undergo transformation.

Kohut's successors disagreed about the generalization of this term. In the view of some, the selfobject reflects vulnerability, even if it is temporary, in the self. An intact Self, according to this view, does not need a selfobject and the notion should be reserved for pathology. However, Kohut's view is clear: The

selfobject is the oxygen that we are only aware of when we think about it. Deficiencies in the self result from the self/selfobject relationship. What was once limited to pathologies is generalizable to every subject and every course of treatment, and pathology stems from narcissism alone. The selfobject preserves the ambiguity of being simultaneously both a relationship and an experience. The metapsychology of the self underlying this concept can be criticized.

AGNÈS OPPENHEIMER

*See also:* Alter ego; Amae, concept of; Disintegration products; Idealized parental imago; Narcissistic injury; Narcissistic rage; Self psychology.

### Bibliography

Kohut, Heinz. (1971). *The analysis of the self*. New York: International Universities Press.

———. (1978). The psychoanalytic treatment of narcissistic personality disorders. In *The search for the self: Selected writings of Heinz Kohut* (Vol. 1). New York: International Universities Press. (Original work published 1968)

———. (1984). *How does analysis cure?* Chicago: University of Chicago Press.

———. (1991). Four basic concepts in self psychology. In *The search for the self: Selected writings of Heinz Kohut* (Vol. 4). New York: International Universities Press. (Original work published 1979)

———. (1991). Selected problems of self psychological theory. In *The search for the self: Selected writings of Heinz Kohut* (Vol. 4). New York: International Universities Press. (Original work published 1980)

## SELF-PRESERVATION

The term *self-preservation* in its simplest definition describes both the set of behaviors by means of which individuals attempt to preserve their own existence and the psychical processes that establish these behaviors.

In an initial period of his work Freud associated these behaviors with the sexual instincts. He claimed that a person's life is conditioned by two major forces: self-preservation instincts, by means of which people preserve their own existence, and sexual instincts, by means of which they ensure the survival of the species. This, he asserted, was fundamental biological data, adding that, as simple observation illustrates, they can

be opposed in conflicts that result in the essentials of psychic dynamics.

Although the notion of “self-preservation” itself did not appear until later, we find it foreshadowed as early as 1895 in “A Project for a Scientific Psychology” (Freud, 1950a), in which Freud accords major importance to attention viewed as the cathexis of perception and thought processes by the ego for the purpose of adaptation. He did not however explicitly formulate his thesis until 1910 in an article on “The Psychoanalytic View of Psychogenic Disturbance of Vision” (1910i, pp. 209–218), where he evoked “the undeniable opposition between the instincts which subserve sexuality, the attainment of sexual pleasure, and those other instincts, which have as their aim the self-preservation of the individual, the ego instincts” (p. 214). He was to return to this question and discuss it in greater detail in “Instincts and their Vicissitudes” (1915c, p. 124): “I have proposed that two groups of such primal instincts should be distinguished: the ego, or self-preserved, instincts and the sexual instincts.” He added cautiously—and somewhat short of his earlier affirmation that it was “fundamental biological data”—that it was merely a working hypothesis.

In this passage we notice that in accordance with the approach opened up in the “Project,” he considers “self-preserved instincts” and “ego instincts” as being equivalent terms and that they are indeed instincts. However, “As the poet has said, all the organic instincts [...] may be classified as ‘hunger’ or ‘love’” (1910i, p. 214–215). This brings up the question as to what is a purely organic need (*Berdürfnis*), what is instinctive behavior (*Instinkt*, in the sense of preformed and automatically executed behavior), and what is drive (*Trieb*, in the sense of a “borderline-concept” between the organic and the psychic). Freud was to be much more explicit on this question in relation to psychosexuality than in relation to self-preservation, which was relegated somewhat to the rear of his theoretical preoccupations. This opposition-complementarity nevertheless plays an important role in the theory that the sexual instincts are connected to the self-preservation instincts, based on the first case of sucking (1905d), and in the opposition between the pleasure principle and the reality principle: the ego instincts force the way to the reality principle, whereas the sexual instincts remain much more durably in the service of the pleasure principle (1911b).

With the arrival of the structural theory and the second theory of instincts opposing life instincts and death instincts, the question takes on new dimensions. All instincts are now seen as libidinal whereas the ego—at the expense of its largely unconscious function—more clearly takes charge of all adaptive functions (in the service of one of its “masters,” the reality of the external world, though simultaneously tyrannized by the other two, the id and the superego). The result is that, in the structural theory with the notion of conflict among the agencies, the status of the notion of “self-preservation” becomes relatively uncertain and the expression “ego instincts” tends to disappear from Freudian vocabulary.

However, several post-Freudian trends have again highlighted the value of the notions of self-preservation instincts and ego instincts, particularly the Paris psychosomatic school (Marty, 1990).

ROGER PERRON

*See also:* Anaclisis/anaclitic; Drive/instinct; Ego-instinct; Eros; Sexual drive; Violence, instinct of.

### **Bibliography**

Freud, Sigmund. (1910i). The psychoanalytic view of psychogenic disturbance of vision. *SE*, 11: 209–218.

———. (1911b). Formulations on the two principles of mental functioning. *SE*, 12: 213–226.

———. (1915c). Instincts and their vicissitudes. *SE*, 14: 109–140.

———. (1950a). Extracts from the Fliess papers. *SE*, 1: 173–280.

Marty, Pierre (1990). *La Psychosomatique de l'adulte*. Paris: Presses Universitaires de France.

## **SELF PSYCHOLOGY**

*Self psychology* is the name Heinz Kohut chose for his psychoanalytic theory, which focused on narcissism.

Beginning with his new metapsychology of the Self in *Restoration of the Self* (1977), Kohut distinguished between the limited form of self psychology proposed in *The Analysis of the Self* (1971), in which he maintained the classical theoretical formulations, and a generalized self psychology that formed a system, albeit a replaceable one. The application of self psychology to other pathologies was the result of further clinical and theoretical elaboration, and also of criti-

cisms leveled against Kohut that may have led him to adopt more or less extreme positions.

Kohut presented the limited form of self psychology as both a complement to Freudian psychoanalysis and a critique of Heinz Hartmann's ego psychology. He held that uncovering narcissistic transference makes it possible to analyze narcissistic personalities, just as transference neuroses do for neurosis. The rehabilitation of narcissism against the ideal of health and maturity led to a preoccupation with development of the self and its defects. Soon, however, postulations concerning the self as a narcissistic structure came into conflict with the theory of the drives. Without eliminating the latter, Kohut considered them to be secondary to the structural defects in the self. The status of neurosis always remained ambiguous in Kohut's work, where it was seen both as a nosological entity unto itself and as being included among the disorders of the self. Neurosis is seen as resulting from oedipal conflicts and castration, but the self is deemed either to be whole at this phase of development, or else already weakened and incapable of resolving the difficulties of the oedipal phase, which then becomes a complex.

Self psychology, through the empathic method advocated by Kohut from 1959, focuses on the self and its fluctuations. It considers microstructures, in contrast to the analysis of neuroses, which focuses on macrostructures—the agencies of the psyche. Self psychology represented an epistemological turning point in which the analyst was no longer, or no longer only, a screen for the patient's projections, but rather a participant in treatment, which the analyst influences; the impact of the analyst's presence and, of course, his or her attitudes and interventions on the patient's narcissism, becomes an object for analysis.

The emergence of self psychology can only be understood in relation to ego psychology, in which the ego, as an agency endowed with functions, is distinguished from self-representations that are the object of narcissistic cathexis. Self-representations are supplanted by representations of the Self, and the Self thus becomes a structure within the psychic apparatus, a reflection of the state of the subject's narcissism.

Self psychology is sometimes considered to be a major deviation from metapsychology. Its focus on a psychology of defects and not only on instinctual conflict has generated a great deal of controversy.

AGNÈS OPPENHEIMER

*See also:* Action-thought (H. Kohut); Alter ego; Bipolar self; Borderline conditions; Compensatory structures; Disintegration products; Ego; Ego (ego psychology); *Empty Fortress, The*; Fragmentation; Grandiose self; Id; Identity; Instance; Kohut, Heinz; Mirror transference; Narcissistic defenses; Narcissistic injury; Narcissistic transference; Object; Paranoia; Principle of identity preservation; Schizophrenia; Self; Self (analytical psychology); Self-image; Self-object; Self-state dream; *Self, the*; Self (true/false); Transference of creativity; Twinship transference/alter ego transference; United States.

### **Bibliography**

- Kohut, Heinz. (1971). *The analysis of the self*. New York: International Universities Press.
- . (1974). *The restoration of the self*. New York: International Universities Press.
- . (1984). *How does analysis cure?* Chicago: University of Chicago Press.

### **Further Reading**

- Goldberg, Arnold. (1988). *A fresh look at psychoanalysis: The view from self psychology*. Hillsdale, NJ: The Analytic Press.
- . (1998). Self psychology since Kohut. *Psychoanalytic Quarterly*, 67, 240–255.

## **SELF-PUNISHMENT**

Self-punishment (or the “need for punishment”) is a tendency, postulated by Freud, which drives certain subjects to inflict suffering upon themselves and search out painful situations, for the purpose of neutralizing a feeling of unconscious guilt. In the framework of the second topography of the psychic apparatus, Freud later attributed self-punishment to the activity of an especially intransigent superego, to which the ego submits.

Freud utilized the two notions “need for punishment” and “self-punishment” throughout his work. The emphasis in the former was on the feeling of unconscious guilt, and on the masochism proper to the ego, which demands punishment, whether it comes from the superego or from the outside, whereas the latter stressed the punishing activity of the superego, to which the ego submits—the superego in turn draws its energy from the reversal of sadism into auto-sadism. Punishment then was applied with no recourse to an external object, through the intervention of internal topographical duality of the ego-superego.

Very early in his career, Freud began noticing a certain number of phenomena and symptoms which conveyed a dimension of self-punishment. In manuscript N (May 31, 1897, in 1950a) he discussed the question of symptom formation and postulated that it constituted a compromise between the libido and the desire for punishment, based on hostile feelings towards the parents: “The motives of *libido* and of *wish-fulfillment as a punishment* then act by summation.” In *The Interpretation of Dreams* (1900a), he distinguished certain “punishment dreams,” whose punitive value allows the lifting of censorship and thereby the realization of certain desires.

Subsequently, the whole field of pathology and all the suffering connected with it came to be looked at through the perspective of self-punishment, whose goal was to satisfy feelings of unconscious guilt:

- in obsessional neurosis, where self-reproach and self-punishing behavior were connected to repressed, aggressive, hostile, and cruel feelings.
- in melancholia, where the self-punishment compulsion can lead to suicide. In a fit of melancholia there is introjection of the lost object and the possibility of unleashing sadism against the object. Without introjection, the guilt of the melancholic prevents the sadism from emerging. After the introjection the sadism can reign unchecked because it is also an attack on the subject, becoming self-punishment (1916–17g [1915]).

Within the second topography, Freud attributed to the superego the punitive role to which the ego submits, and culpability became a tension between the two entities. He emphasized also that some behavior can be motivated by the quest for punishment. For example, the transgressing subject, by obtaining punishment, is looking to gratify a desire for masochistic satisfaction (1928b [1927]). Freud was especially interested in what he called the negative therapeutic reaction, where the repressed sadism of the patient inclines him to sabotage the cure, combining revenge against the therapist with self-punishment.

More recent works have attempted to distinguish more clearly between guilt and moral masochism. Schematically, it can be averred that in neurotic guilt, the sadism of the superego is in control, while in moral masochism, the ego eroticizes the feeling of guilt. The desire for punishment is then resexualized

in a regressive way, becoming the source of masochistic satisfactions.

BERTRAND ÉTIENNE AND DOMINIQUE DEYON

*See also:* Aimée, case of; Castration complex; “Dostoyevsky and Parricide”; Guilt, feeling of; Moral masochism; Suicide; Superego.

### **Bibliography**

- Freud, Sigmund. (1900a). The interpretation of dreams. Parts I and II. *SE*, 4–5.
- . (1916–17g [1915]). Mourning and melancholia. *SE*, 14: 237–258.
- . (1923b). The ego and the id. *SE*, 19: 1–66.
- . (1924c). The economic problem of masochism. *SE*, 19: 155–170.
- . (1928b [1927]). Dostoevsky and parricide. *SE*, 21: 173–196.
- . (1950a [1887–1902]). Extracts from the Fliess papers. *SE*, 1: 173–280.
- M’uzan, Michel de. (1972). Un cas de masochisme pervers. In *La Sexualité perverse*. Paris: Payot.
- Nacht, Sacha. (1971). Le transfert. In *Guérir avec Freud* (pp. 41–43). Paris: Payot. (Original work published 1965)
- Rosenberg, Benno. (1991). *Masochisme mortifère et Masochisme gardien de la vie*. Paris: Presses Universitaires de France.

### **Further Reading**

- Fenichel, Otto. (1928). The clinical aspect of the need for punishment. *International Journal of Psychoanalysis*, 9, 47–70.
- Roth, Bennett. (2000). The piano: A modern film melodrama about passion and punishment. *Psychoanalytic Psychology*, 17, 405–413.

## **SELF-REPRESENTATION**

Self representation is the image the subject has of him or herself based on his or her own interpretation. It is one of the factors of the ego and its representation as termed “an individual, differentiated, real, and permanent entity” (Racamier) particularized by a distinctive history and modes of feeling, thinking, and doing.

This accounts for Heinz Hartmann’s distinction between, on the one hand, the ego as a function and

the self as the object of narcissistic investment, and, on the other, “object representations” and “self representations,” meaning the unconscious, preconscious, and conscious representations of the corporeal and mental self within the system of the ego, representations that are invested with both libidinal and destructive energy to become love objects and objects of hatred.

Jacques Lacan took a different approach. In “The Mirror Stage as Formative of the Function of the I as Revealed in Psychoanalytic Experience” (1949/2004), he described the mirror stage as “a drama whose internal pressure pushes precipitously from insufficiency to anticipation—and, for the subject caught up in the lure of spatial identification, turns out fantasies that extends from a fragmented image of the body to what I call “orthopedic” form of its totality—and to the finally donned armor of an alienating identity that will mark his entire mental development with its rigid structure” (p. 6).

Thus self representation is just of one aspect of the subject’s representations, marked by its belonging to the ego—that is, its insertion into reality, the aim of a substantial coherence with its narcissistic dimension and the lure it implies. To varying degrees it can be destabilized, called into question, unmasked by desires and conflicts, or seriously disturbed. The latter may take the form of the radical self-depreciation of melancholia, the overvaluation of self in mania, or a collapse into schizophrenia, where a more or less delusional new self representation is reconstituted as savior of the world, self-creator of all human lineages, of other such variant. Other less dramatic but particularly trying forms occur when the self representation is called into question in borderline states or transformed into transsexualism.

Any existential crisis, particularly in adolescence, can challenge or cause serious disturbances in self representation. These occur in anorexia, bulimia, dysmorphophobia (fear of deformity), or psychotic decompensation, all considered by American authors as defects in self-representation or as pathologies of identity (Erikson). Among the various elaborations proposed by authors who espouse Hartmann’s conception, Edith Jacobson’s has the merit of showing the correlation between the self and the object world, between identity and the feeling of identity within a framework that combines individuation and identification, and thus grants a determining role to the unconscious.

RAYMOND CAHN

*See also:* Object; Object relations theory; Self; Self-image.

### Bibliography

- Erikson, Erik H. (1968). *Identity: Youth and crisis*. New York: Norton.
- Jacobson, Edith. (1964). *The self and the object world*. New York: International Universities Press.
- Lacan, Jacques. (2004). The mirror stage as formative of the function of the I as revealed in psychoanalytic experience. In *Écrits: A selection* (Bruce Fink, Trans.), pp. 3–9. New York: Norton. (Original work published 1949)
- Racamier, Paul-Claude. (1963). Sur la personnation. In *De psychanalyse en psychiatrie*. Paris: Payot.

### SELF-STATE DREAM

Heinz Kohut believed that there were two types of dreams: the first expresses verbalizable latent contents, such as conflicts; the second expresses efforts to bind the nonverbal tensions of traumatic states. In the first type, the analyst can follow the free associations of the patient to uncover unconscious meaning. In the second, free associations do not lead to unconscious layers of the mind; rather, the imagery remains on the same level as that of the manifest content. Examination of the manifest content reveals that the healthy sectors of the psyche of the patient are reacting to a changed condition of the self, either overstimulation or depletion or a threatened dissolution. This second type of dream is called a “self-state dream” and is similar to dreams occurring in traumatic states. The correct interpretation of such dreams is to recognize the patient’s specific and general vulnerabilities.

Other writers after Kohut have expanded on his idea, stating that nearly all dreams can be seen as representing the state of the self in that they all express some vulnerability and/or psychoeconomic imbalance. On this view, a dream may be interpreted both as to its latent content and as to its portrayal of the self. These authors see no inherent contradiction in Kohut’s dualistic view of dreams, though some have suggested that patients have limited capacity for association.

ARNOLD GOLDBERG

*See also:* Dream; Self psychology.

### Bibliography

- Kohut, Heinz. (1977). *The restoration of the self*. New York: International Universities Press.

### SELF, THE

The concept of the Self that was proposed by Heinz Kohut in *The Analysis of the Self* (1971) is not a Freudian concept and it does not appear as such in the *Vocabulaire de la psychanalyse* (Laplanche and Pontalis); nor does another concept of self that refers to the narcissistic axis of the psyche. When Freud spoke of the instinctive mechanism of “turning around upon the subject’s own self” in “Instincts and Their Vicissitudes” (1915c, p. 126), he did not mean the subject’s own self as an intrapsychic entity, but rather an equivalent of the subject’s own body, upon which the second phase of the drives was founded.

The concept of “Self” is really the invention of Heinz Kohut: the Freudian idea of the “splitting of the ego,” through the Kleinian idea of the splitting of the object molding the ego, by way of the mechanisms of introjection and projection, finally to the Kohutian idea of a Self, which becomes the object of all the narcissistic cathexes.

Understanding Kohut’s model is only possible within the context of the history of ideas. In the 1960s the nosographic concept of limit-states and *borderline* pathologies, belonging neither to neurotic nor psychotic structures, surfaced. This resulted in the progressive delineation of hybrid or composite disorders, centered on issues linked to representation or identity of the Self—that is to say, in the last resort, to narcissistic personality disorders (Otto Kernberg).

Researchers and clinicians had swung back-and-forth from the oedipal to the narcissistic axis. This seesawing may be what is behind the emergence of the concept of Self. In effect, Heinz Kohut proposed a new theory of the ego, adding a notion of the Self, partially of Winnicottian provenance (c.f. Winnicott’s false self) to the Freudian *Ich*.

In any case, the Kohutian theory of the Self has shown itself to be quite fecund. It has had considerably more of an impact in the Anglo-Saxon world than in Europe, especially in France, where it has been often understood as an attempt to desexualize psychopathology, or even as something similar to the ego psychology of Heinz Hartmann, Ernst Kris, and Rudolph M. Loewenstein. Even Kohut has been very critical of the so-called psychology of the ego. Anxious to purify psychoanalysis of any notion foreign to its domain, Kohut first defined empathy as specific to psychology, thinking of it as a technique of vicarious introspection

enabling knowledge of another's psyche. He did this as part of the larger project of extending psychoanalysis to types of personalities previously thought unanalyzable.

Having defined two particular transferences, the "mirror transference" and the "idealizing transference," he reconsidered the question of narcissism, which, according to him, could not be understood as a simple libidinal retreat into the ego. For Kohut, the quality of lived experience defines narcissism, which he then opposes to what he termed a "Self-object" relation, in which other people seem to exist predominantly in roles defined by function. In the cure, as in psychic ontogenesis, narcissism and object love develop conjointly and interactively, with Self-object roles finding themselves gradually interiorized in the form of internal regulatory structures (there is a hint of a goal of adaptation in this model).

On this basis, in *The Analysis of the Self* (1971), Heinz Kohut proposed what he called a restricted theory of the Self and, later, what he called a general theory of the Self. This was presented as complementary to Freudian theory, but in reality it attempted to subsume the latter into a larger model. The Self became progressively a relatively autonomous principle of motivation, integrating the drives, and accorded its own program of realization; it no longer was separate from the Self-object, a concept that was enlarged to include the entire narcissistic dimension of experience. A third kind of transference was described as "alterego transference," where the controlling element is the need for a peer, particularly someone of the same sex. For Kohut, the Self is something very much different from intrapsychic entities like the ego, id, or superego.

Beyond a certain number of notions, like the corporal or archaic Self, the nuclear Self, the consistency of the self, the permanent disintegration of the self, the fragmented self, and self-esteem, Kohut has particularly emphasized the notion of the grandiose Self to try to account for "the child's solipsistic vision of the world and the manifest pleasure he derives from the admiration he receives from it." However, his descriptions of the grandiose Self cover a wide range of phenomena, from "paranoiac delirium and the crudely sexual acts of the adult pervert, to certain kinds of simple, sublimated satisfaction that adults derive from what they are, what they do, and what they succeed in."

Some authors have attempted to deal with the concept of Self from a more topical point of view.

Among them is Jean Bergeret, who describes the ego ideal as originating in the maternal, rather than the paternal, attachment. Finally, the concept of the Self, in spite of all ambiguity and the criticism directed at it, has been shown to be of heuristic value; it has influenced many works, including *The Privacy of the Self* (1974), by Masud Khan, and, more recently *The Forces of Destiny* (1989) by Christopher Bollas. For Bollas, the destiny of the subject is the result of an encounter with an object; certain objects favor the emergence of the true Self, while others obstruct and condemn the individual to organize himself around a false Self.

Donald W. Winnicott has also used the notion of the Self in developing his work on the "false self." Both concepts, however, invite questions about the status of the Freudian theory of drives, which runs the risk of being somewhat obscured.

BERNARD GOLSE

*See also:* Self psychology.

### **Bibliography**

- Bollas, Christopher. (1989). *The forces of destiny*. London: Free Association Books.
- Freud, Sigmund. (1915c). Instincts and their vicissitudes. *SE*, 14: 109–140.
- Kernberg, Otto F. (1975). *Borderline conditions and pathological narcissism*. New York: Jason Aronson.
- Khan, Masud. (1974). *The privacy of the self*. London: Hogarth.
- Kohut, Heinz. (1971). *The analysis of the self*. New York: International Universities Press.
- Laplanche, Jean, and Pontalis, Jean-Bertrand. (1967). *Vocabulaire de la psychanalyse*. Paris: Presses Universitaires de France.
- Oppenheimer, Agnès. (1995). Psychanalyse du Moi, psychologie du Moi et psychologie du Self. *Encyclopédie médico-chirurgicale* (Vol. *Psychiatrie*).

---

## **SELF, THE (ANALYTICAL PSYCHOLOGY)**

Jung originally defined his concept, "the Self," (Selbst), as follows: "As an empirical concept, the Self designates the whole range of psychic phenomena in man. It expresses the unity of the personality as a whole."

“But insofar as the total personality, because of its unconscious component, can only be partly conscious, the concept of the Self is, in part, only potentially empirical and is to that extent a postulate. In other words, it encompasses both the experienceable and the unexperienceable (or the not-yet experienced). From an intellectual point of view it is only a working hypothesis. Its empirical symbols, on the other hand, very often possess a distinct numinosity, that is, an emotional value. It thus proves to be an archetypal idea . . . which differs from other ideas of the kind in that it occupies a central position befitting the significance of its content and numinosity.”

Of the content and development of his ideas, Jung wrote: “The Self appears in dreams, myths, and fairy tales in the figure of a ‘supra-ordinate personality,’ such as a king, prophet, or savior, etc., or in the form of a totality symbol, such as the circle, square. . . . When it represents . . . a union of opposites it can also appear as a united duality in the form, for instance, of Tao as the interplay of Yang and Yin.” Related ideas pertaining to Self-symbolism were initially described by Jung: “The Self is not a philosophical idea since it does not predicate its own existence.”

By way of critical appraisal the *Journal of Analytical Psychology* published a symposium on the self in 1985. In Joseph L. Henderson’s contribution it is written: “I am impressed with how much serious thinking by Jungian analysts has gone into clarifying the multifaceted subject. For the most part the theoretical basis as expressed by Jung himself has been reaffirmed, namely that the Self as a symbol of totality of psychic life and as a central archetype of order equally exist.”

But if we place metaphor to one side and look at the manifestation of self-hood in action we may find our centering totality at work in more humanly understandable forms, as in analysis where analyst and analysand enter into a common ego-self relationship.

The self in this context approaches the concept of the self in other psychologies, such as Kohut’s self-psychology. Perhaps Jungians are in general becoming more comfortable with self as a psychological concept only and less in awe of the self as an archetype with its metaphysical aura.

Knowing the danger that too much emphasis upon the self may have an inflationary effect on the ego (grandiosity), or that too little emphasis upon it may aggrandize the importance of ego consciousness over

the unconscious, normal self-definition is found where ego and self are separate but inherently related. Jung writes: “Sensing the Self as something irrational, as an undefinable existent, to which the ego is neither opposed or subjected, but merely attached, and about which it revolves very much as the earth revolves around the sun—thus we come to the goal of individuation.” The individuated ego senses itself as the object of an unknown and supra-ordinate subject. It seems that a psychological inquiry might come to a stop here.

JOSEPH L. HENDERSON

*See also:* Archetype (analytical psychology); Compensation (analytical psychology); Ego (analytical psychology); Individuation (analytical psychology); Numinous (analytical psychology); Projection and “participation mystique” (analytical psychology); Psychological types (analytical psychology); Shadow (analytical psychology); Transference (analytical psychology).

### **Bibliography**

- Henderson, Joseph L. (1985). The self in review. *Journal of Analytical Psychology*, London, 30, p. 243–246.
- Jung, Carl Gustav. (1923). Psychological types. *Coll. works*, Vol. VI. Bollingen Series XX. Princeton, N.J., Princeton University Press, 1971, p. 460–461.
- Kohut, Heinz. (1971). *The analysis of the self*. New York, International Universities Press.
- . (1977). *The restoration of the self*. New York, International Universities Press.

---

## **SELF (TRUE/FALSE)**

Donald Winnicott used the term “self” to describe both “ego” and self-as-object. He describes the self in terms of a psychosomatic organization, emerging from a primary state of “unintegration” by gradual stages. The true self, which in health expresses the authenticity and vitality of the person, will always be in part or in whole hidden; the false self is a compliant adaptation to environmental impingement.

This characteristically fluid use of the term can be traced throughout his work, evolving in terms of true and false selves. The first paper to clarify the existence of true and false selves as entities is “Aggression in Relation to Emotional Development” (1950–55). Winnicott, from within his own object-relations



theory, postulates the necessity for the innate maturational tendency to operate within the facilitating environment (1960). This is expressed in terms of the individual baby's need for an environment allowing uninterrupted continuity of being, which lays the foundations for psychosomatic integration, aliveness, and the beginnings of awareness of self, true self being "the summation of sensori-motor aliveness." In several papers, notably "Primary Maternal Preoccupation" (1956) and "Ego Distortion in Terms of True and False Self," (1960) he describes the exquisite adaptation, or primary maternal preoccupation in the new mother, whose handling (and in particular, holding) of her infant, protects the baby from "impingement," or environmental failure. Within such holding, which must involve both physical contact and empathic attunement, "going on being" is supported, and this allows the beginning of individuation. Environmental failure at this stage, when primitive agonies threaten, can result in psychosis, which Winnicott thought of as an environmental deficiency disease (1949).

Later, careful maternal adaptation must of necessity fail, gradually, and in stages (good-enough mothering), at such a pace that the developing infant can manage each stage, and replace each environmental lack with mental activity. Early on, the "good-enough mother" succeeds repeatedly in meeting and realizing the infant's sensory hallucination, or "gesture," thus allowing in infantile sense of omnipotence and the development of the later capacity for symbolization. With gradual failures of response from mother, the infant's experience of omnipotence can then be gradually relinquished, and recognition of reality, together with spontaneity and authenticity, becomes possible—the "true self."

The "not-good-enough mother" cannot respond sensitively and empathically, and fails to "meet the infant's gesture." While the infant can adapt to this up to a point, filling the gap with hallucination, eventually this mechanism fails and the infant loses touch with their own needs, responds excessively to the environment, and becomes "impinged upon," traumatized, and incapable of symbol-usage. At this point the infant, seduced into compliance, develops a "false self," reacting to environmental demands and relinquishing or hiding the remnants of spontaneity, the "true self." The existence of the "false self" is a defense against the feared annihilation of the true self, and becomes a

"caretaker self," taking over those functions unfulfilled by mother.

In some infants, particularly those well endowed with intellectual potential, the mind becomes the "caretaker self," over-valued and in conflict with the psyche-soma (1949). Winnicott described five degrees of false self formation, from severe limitation of spontaneity and liveliness with convincing imitation of normality, to those ordinary social adaptations necessary for life in human society. False self personalities may be superficially successful, but empty; they may become caretakers of others while being unable to allow dependency in themselves.

Winnicott believed that in psychoanalysis regression was a necessary phase for "false self personalities," in order to work through the earliest environmental failures. He advised against inexperienced analysts taking on this kind of work.

Winnicott's work has been usefully adapted in several ways. For Ronald Fairbairn, the "schizoid personality" derives from his understanding that the infant's primary need is for intimacy. In his reading environmental failure leads to splitting and to defenses against it. Michael Balint's "harmonious mix-up" can be seen as an early undifferentiated phase; his ideas about the "basic fault" relate to primary position of the infant's desire to be loved by its mother. Heinz Kohut develops a "psychology of the self" and describes "maternal self-object functioning." Margaret Mahler locates in early childhood a "symbiotic fusion" with the mother, and describes separation/individuation phases. Daniel Stern compares the "core self" and the "self with other."

Winnicott, while not abandoning drive theory, stresses the importance of relationships from the beginning. His writing is elusive, idiosyncratic, and often cryptic. Unlike Melanie Klein, whose concern was with the infant's internal, often instinctual struggles, his focus was on the emergence of the individual from the earliest relationship, an emergence which could be adversely affected by either impingement or deficiency of provision.

JENNIFER JOHNS

*See also:* Addiction; Anality; As if personality; Autistic capsule/nucleus; Breakdown; Child analysis; Creativity; False self; Good-enough mother; Holding; Integration; Internal object; Lie; Narcissism; Object; Protective shield,

breaking through the; Self; Splitting; Transitional phenomena.

### Bibliography

Winnicott, Donald. (1949). Mind and its relation to the psych-soma. *British Journal of Medical Psychology*, 27, 1954; and in *Collected papers, through paediatrics to psycho-analysis*. London: Tavistock Publications, 1958, pp. 243–254.

———. (1955). Aggression in relation to emotional development. In *Collected papers, through paediatrics to psycho-analysis*. London: Tavistock Publications, 1958, pp. 204–218.

———. (1956). Primary maternal preoccupation. In *Collected papers, through paediatrics to psycho-analysis*. London: Tavistock Publications, 1958, pp. 300–305.

———. (1962). Ego distortion in terms of true and false self. In *Maturational processes and the facilitating environment*. London: Hogarth Press and the Institute of Psychoanalysis, 1965, pp. 140–152.

---

## SEMINAR, LACAN'S

In contrast with Freud, whose work was primarily written, Jacques Lacan's work was for the most part an oral improvisation from notes delivered as an ongoing seminar that he held in Paris from 1953 to 1980. From 1953 to 1963, Lacan's seminar was held at the Sainte-Anne Hospital in Paris. From 1964 to 1969, starting with seminar 11, it was held at the École Normale Supérieure on rue d'Ulm. And finally, from 1969 to 1980, starting with seminar 17, it was held before a much larger audience in the amphitheater of the law school at the Panthéon.

Even during Lacan's lifetime, the seminar circulated in the form of photocopies of diverse and unreliable written versions of the spoken text. Beginning in 1973, Lacan entrusted the transcription of the seminar to Jacques-Alain Miller. In an editor's note to *The Four Fundamental Concepts of Psychoanalysis*, the first of his publications of Lacan's seminars, Miller wrote, "My intention here was to be as unobtrusive as possible and to obtain from Jacques Lacan's spoken work an authentic version that would stand, in the future, for the original, which does not exist" (p. xi).

The individual seminars that make up Lacan's seminar are as follows:

a) Seminar 1 (1953–1954): *Freud's Papers on Technique*. (John Forrester, Trans.) New York: W. W. Norton, 1988.

b) Seminar 2 (1954–1955): *The Ego in Freud's Theory and in the Technique of Psychoanalysis*. (Sylvana Tomaselli, Trans.) New York: W. W. Norton, 1988.

c) Seminar 3 (1955–1956): *The Psychoses*. (Russell Grigg, Trans.) New York: W. W. Norton, 1993.

d) Seminar 4 (1956–1957): *La relation d'objet* (Object relations). Paris: Seuil, 1994.

e) Seminar 5 (1957–1958): *Les formations de l'inconscient* (Formations of the unconscious). Paris: Seuil, 1998.

f) Seminar 6 (1958–1959): *Le désir et son interprétation* (Desire and its interpretation). Unpublished.

g) Seminar 7 (1959–1960): *The Ethics of Psychoanalysis*. (Dennis Porter, Trans.) New York: W. W. Norton, 1992.

h) Seminar 8 (1960–1961): *Transfert* (Transference). 2nd ed. Paris: Seuil, 2001.

i) Seminar 9 (1961–1962): *L'identification* (Identification). Unpublished.

j) Seminar 10 (1962–1963): *L'angoisse* (Anxiety). Paris: Seuil, 2004.

*Name-of-the-Father* was to be the next seminar, but only a single session was given, on November 25, 1963, at Sainte-Anne Hospital. Lacan stopped giving this seminar when he learned that the International Psychoanalytical Association had refused to reinstate him as a training analyst.

k) Seminar 11 (1964): *The Four Fundamental Concepts of Psychoanalysis*. (Alan Sheridan, Trans.) New York, W. W. Norton, 1978.

l) Seminar 12 (1964–1965): *Problèmes cruciaux pour la psychanalyse* (Crucial problems for psychoanalysis). Unpublished.

m) Seminar 13 (1965–1966): *L'objet de la psychanalyse* (The object of psychoanalysis). Unpublished.

n) Seminar 14 (1966–1967): *La logique du fantasme* (The logic of fantasy). Unpublished.

o) Seminar 15 (1967–1968): *L'acte psychanalytique* (The psychoanalytic act). Unpublished.

p) Seminar 16 (1968–1969): *D'un Autre à l'autre* (From one Other to the other). Unpublished.

q) Seminar 17 (1969–1970): *L'envers de la psychanalyse* (The other side of psychoanalysis). Paris: Seuil, 1991.

- r) Seminar 18 (1970–1971): *D'un discours qui ne serait pas du semblant* (On a discourse that might not be a semblance). Unpublished.
- s) Seminar 19 (1971–1972): ... *ou pire* (... or worse). Unpublished.
- t) Seminar 20 (1972–1973): *On Feminine Sexuality: The Limits of Love and Knowledge, Encore*. Translated by Bruce Fink. New York: Norton, 1998.
- u) Seminar 21 (1973–1974): *Les non-dupes errent* (Those who are not duped err). Unpublished.
- v) Seminar 22 (1974–1975): *R.S.I. Ornica? 2–5*.
- w) Seminar 23 (1975–1976): *Le sinthome* (The sinthome [an archaic spelling of the word “symptom”]). *Ornicar? 6–11*.
- x) Seminar 24 (1976–1977): *L'insu que sait de l'une bévue s'aile à mourre*. *Ornicar? 12–18*.

The punning French title of this seminar is based on a fanciful French translation of the German word for the unconscious, “Unbewusste,” as “une-bévue,” which means a blunder or a mistake. As written, the title might be translated as “The unknown that knows about the one-blunder chances love.” But as spoken, with written puns ignored, the French title might be rendered most simply as “L'insuccès de l'une-bévue, c'est l'amour,” which means “Love is the failure of the one-blunder.”

- y) Seminar 25 (1977–1978): *Le moment de conclure* (Time to conclude). Unpublished.
- z) Seminar 26 (1978–1979): *La topologie et le temps* (Topology and time). Unpublished.
- aa) Seminar 27 (1980): *Dissolution*. *Ornicar? 20–23*.

Because Lacan was old and ill, seminar 27 was not delivered publicly but only published. It dealt with the dissolution of his school, École freudienne de Paris (Freudian School of Paris).

JACQUES SÉDAT

See also: Delay, Jean; École freudienne de Paris (Freudian School of Paris); France; Lacan, Jacques-Marie Émile; Merleau-Ponty, Maurice; *Ornicar?*; Sainte-Anne Hospital; Splits, psychoanalytic.

### Bibliography

Dor, Joël. (1994). *Nouvelle bibliographie des travaux de Jacques Lacan*. Paris: E.P.E.L.

École Lacanienne de psychanalyse. (1991). *Le transfert dans tous ses errata and Pour une transcription critique des séminaires de Jacques Lacan*. Paris: E.P.E.L.

Miller, Jacques-Alain. (1985). *Entretien sur le séminaire avec François Ansermet*. Paris: Navarin.

---

## SENSE/NONSENSE

Unlike meaning (*signification*), which unites a signifier, the material manifestation of the sign, to a signified, the concept to which it corresponds, sense (*sens*) has an axiological dimension: It is a sense “for” and orders a behavior by linking an object to a desire. Jacques Lacan (1966) and Piera Aulagnier (*The Violence of Interpretation: From Pictogram to Statement, 1975/2001*) showed that the preverbal infant's manifestations of needs are interpreted by the mother as signs that have a sense. She will consequently respond to them according to her own desire, which will or will not be in agreement with the sense that she has given to the infant's demand. The latter's responses will in turn take on sense and value for her. Sense later corresponds to a need for causality that constitutes, in the realm of thought, the equivalent of a rediscovery of the earliest experience of satisfaction.

In Lacan's work there is a specific theory of sense that will not be treated here. In the work of Sigmund Freud, this issue was essentially addressed in connection with jokes and the pleasure of sense in nonsense. Traces of the issue are nevertheless present elsewhere, particularly in all of the manifestations of the unconscious that the subject takes to be absurd or devoid of sense. However, Freud was much more specific about absurdity in dreams, which is not just a product of its noninterpretation. In *The Interpretation of Dreams* (1900), he wrote: “A dream is made absurd, then, if a judgement that something ‘is absurd’ is among the elements included in the dream-thoughts—that is to say, if any one of the dreamer's unconscious trains of thoughts has criticism or ridicule as its motive. Absurdity is accordingly one of the methods by which the dream-work represents a contradiction. . . . Absurdity in a dream, however, is not to be translated by a simple ‘no’; it is intended to reproduce the *mood* of the dream-thoughts, which combines derision or laughter with the contradiction” (pp. 434–435). This is the laughter of irony, the oedipal game par excellence, for it perverts the identification that is supposedly necessary to the edification of the superego by

identifying not with the manifest level of what is given as an example, but with its latent, infantile, and instinctual content. In this, the joke converges with the art of the ellipsis characteristic of ironic persiflage, by actualizing what Freud, in “Jokes and Their Relation to the Unconscious” (1905), calls an “omission without a substitute” (p. 77), in which the forbidden representation disappears.

How does nonsense become a joke? The nonsense contained in a joke is in fact a criticism; it imitates a supposedly profound proposition that in reality is ridiculous or a sophistry, and, precisely in doing so, reveals the nonsense behind its respectable appearance. Hence Freud’s formulation in “Jokes and Their Relation to the Unconscious”: “[I]n jokes nonsense often replaces ridicule and criticism in the thoughts lying behind the joke” (p. 107). However, the tendentious joke also uses a technique characteristic of jokes in general, which is “pleasure in nonsense” (p. 125), a relic of the pleasure of playing with words for their assonance alone, independent of meaning. Children, like adults, give themselves up to this pleasure, fully aware of its absurdity, just for the sake of the attraction of fruit forbidden by reason. Inherent in this is a perspective that goes beyond tendentious wit, since the capacity for rational thought is what is challenged here.

In “Jokes and Their Relation to the Unconscious” Freud associated this pleasure of untrammelled nonsense with adolescence, but also with adults in a relaxed state, especially as a result of drinking alcohol. He cited as examples the “cheerful nonsense of the *Bierschwefel* (a ludicrous speech delivered at a beer party)” and the *Kneipzeitung* (literally, “tavern newspaper”; a comic set of minutes), and noted: “Under the influence of alcohol the grown man once more becomes a child, who finds pleasure in having the course of his thoughts freely at his disposal without paying regard to the compulsion of logic” (p. 126). Pleasure in nonsense, a challenge to the constraints of reason and a narcissistic claim to being the omnipotent master of meaning, appeared to Freud to be the basis for the “sense in nonsense” factor: “The psychogenesis of jokes has taught us that the pleasure in a joke is derived from play with words or from the liberation of nonsense, and that the meaning of the joke is merely to protect that pleasure from being done away with by criticism” (p. 131). In the mind, nonsense appears as an end unto itself, and “the intention

of recovering the old pleasure in nonsense is one of the joke-work’s motives” (p. 176).

However, we can wonder about the function of this challenge, precisely because it allows sense to subsist. More than a destruction, at issue here is a condensation that brings to light contradictions, and this process could be compared to what Freud wrote in “The Antithetical Meaning of Primal Words,” emphasizing, with the linguist Karl Abel, that “our concepts owe their existence to comparison” (p. 157) and in consequence they simultaneously express contradictory images, each of them ensuring its pregnancy by its relational dependence on the other.

For sense constitutes a fundamental need, and when the a-sense of psychosis develops, this again involves a sense in revolt against another that has been unduly imposed upon the subject. Aulagnier showed how psychosis does not stem from a revolt of the id against reality, as Freud stated, but rather from “the struggle the infantile psyche puts up each time it is confronted with the powerlessness of the maternal discourse to make sense of lived experience and with the overwhelming power of the mother’s desire to appropriate the ‘thinking activity’ of the child.” Aulagnier, like Wilfred Bion (1963), showed how the mother substitutes for the a-sense of the real a reality that is cathected and thought by the mother, who retransmits it to the baby. This work of sense-making is later incumbent upon the I itself, and accordingly, causal explanations are a part of what is necessary for thought. This sense is not abstract, for it is initially a libidinal sense, all acts of knowledge being preceded by an act of cathexis. Constructing sense makes the I’s relationship to reality coherent; such, then, is the primary function of the activity of thinking and, accordingly, delusions themselves will have as their function the creation of a meaningful interpretation of the violence undergone by the subject (Mijolla-Mellor).

SOPHIE DE MIJOLLA-MELLOR

*See also:* Abel, Carl; Bulimia; Infans; Jokes; Manifest; Metonymy; Need for causality; “Psycho-Analytic Notes on an Autobiographical Account of a Case of Paranoia (Dementia Paranoides)”; Remembering.

### **Bibliography**

Aulagnier, Piera. (2001). *The violence of interpretation: From pictogram to statement.* (Alan Sheridan, Trans.). Hove, UK,

- and Philadelphia: Brunner/Routledge. (Original work published 1975)
- Bion, Wilfred. (1963). *Elements of psycho-analysis*. London: Heinemann.
- Freud, Sigmund. (1900a). *The interpretation of dreams*. *SE*, 4–5: 1–625.
- . (1905c). Jokes and their relation to the unconscious. *SE*, 8: 1–236.
- Mijolla-Mellor, Sophie de. (1998). *Penser la psychose: Une lecture de l'oeuvre de Piera Aulagnier*. Paris: Dunod.

## SERVADIO, EMILIO (1904–1994)

Emilio Servadio, an Italian physician and psychoanalyst, was born in Sestri (Genoa) in 1904 and died in Rome in 1994. Servadio was born into a Jewish family and studied in Genoa, where he received a law degree. He wrote his dissertation on forensic medicine, specifically about hypnosis. It was the beginning of his interest in paranormal phenomena, which became one of his primary areas of research throughout his life.

Servadio was the editor of the *Enciclopedia italiana Treccani* in Rome, where he settled in 1929. He met Edoardo Weiss and asked him to write several articles on psychoanalysis for the encyclopedia. Weiss, in turn, began analyzing Servadio, who became a devoted student of psychoanalysis. After his departure for America, he remained in contact with Servadio, who was always grateful to Weiss for the role he played in his training.

In 1934 at the Lucerne Congress, in which the Italian contingent, led by Weiss, participated for the first time, Servadio made his first appearance on the international psychoanalytic scene by presenting a study on the links between psychoanalysis and telepathy. His paper, “Psychoanalysis and Telepathy,” was subsequently published in *Imago*. For the time it was an innovative and courageous work, in which he tried to relocate the telepathic phenomena that occur during the course of a séance within the framework of the patient-analyst relationship.

Far from leading Servadio to abandon an original field of research, his encounter with psychoanalysis—as his most brilliant student, Eugenio Gaddini, has written—enabled him to “investigate as fully as possible his initial aspirations and make use of an investigative method appropriate to the study of paranormal phenomena.”

Servadio’s use of psychoanalysis was unconventional and could have had an influence on psychoanalysis through his focus on the scope of counter-transference phenomena, which he wrote about in 1962 in an article that appeared in the *Rivista di psicoanalisi* (VIII, [2]). In 1939, because of the race laws then in effect in Italy, he was forced to leave the country. He settled in India, attracted by Asian cultures and ancient religions.

After his return to Italy in 1946, Servadio was, together with Nicola Perrotti and Cesare Musatti, one of the principal protagonists in the rebirth of psychoanalysis in the country. In 1962 he created a center for psychoanalysis in Rome and was president of the Italian Psychoanalytic Society (SPI) from 1964 to 1969.

Servadio was highly esteemed within the International Psychoanalytic Association (IPA) and was a friend of Anna Freud, Marie Bonaparte, and Ernest Jones; within the Italian psychoanalytic movement he played the role of institutional tutor. At the end of the 1950s, he visited Weiss, then in America, to request that an audit committee from the IPA come to Italy to ensure that its training regulations were consistent with international norms. In 1992, leading a minority group that had broken with the SPI, he helped form a second Italian Psychoanalytic Society, which was recognized by the IPA in 1993.

Although Servadio was intransigent in institutional matters and a brilliant writer and popularizer of psychoanalysis, he was very open-minded in matters of behavior and current events. He was a prolific writer, primarily in the field of applied psychoanalysis, with essays on a wide range of topics. They include his “Funzione dei conflitti preedipici” (Functions of pre-oedipal conflicts), published in 1953 in the *Rivista di psicoanalisi* (republished in issue 20 [3], 1974, devoted to Servadio), which remains his most important contribution to metapsychology.

ANNA MARIA ACCERBONI

*See also:* Congrès des psychanalystes de langue français des pays romans; India; Italy.

### Bibliography

- Errera, Giovanni. (1990). *Emilio Servadio: Dall'ipnosi alla psicoanalisi*. Florence: Nardini.
- Gaddini, Eugenio. (1974). I settanta anni di Emilio Servadio: Un tributo. *Rivista di psicoanalisi*, 20 (2), pp. 5–13.

Novelletto, Arnaldo. (1995). Emilio Servadio. *Rivista di psicoanalisi*, 61 (1), pp. 171–179.

Servadio, Emilio. (1935). Psychoanalyse und Telepathie. *Imago*, 23, pp. 489–497.

——— (1955). A presumptively telepathic precognitive dream during analysis. *International Journal of Psychoanalysis*, 36, pp. 27–30.

## “SEVENTEENTH-CENTURY DEMONOLOGICAL NEUROSIS, A”

In this work Sigmund Freud examined the case of Christopher Haitzmann, a painter whose story he had learned from documents preserved in the sanctuary at Mariazell (in Lower Austria).

According to these documents, in 1668 Haitzmann wrote and signed in his own blood a pact with the Devil, thereby becoming his son and, in addition, vowing to belong to him body and soul nine years later. In 1677, when the nine years were almost up, Haitzmann was seized with remorse and terror, asked for help from monks, and was freed from his promise through the intercession of the Virgin Mary. Among the documents preserved at Mariazell are his diary, relating the apparitions of Satan, paintings by Haitzmann himself illustrating these scenes, and texts written by monks who witnessed or were commenting on the miracle. These documents were the basis for Freud’s analysis.

Freud emphasized the evidence of the psychopathological problems afflicting this man. He further noted that the “pact with the Devil” had been concluded at a time when Haitzmann, having no commissions and suffering from serious inhibitions in his work, had been reduced to poverty. This distress grew more acute at the death of his father, and shortly thereafter he declared himself to be Satan’s son, thus instituting Satan as a father substitute—although in Haitzmann’s paintings Satan was depicted with monstrous breasts. Referring back to the Schreber case, published twelve years earlier, Freud interpreted this “demonological neurosis” as stemming from Haitzmann’s homosexual position in relation to his father, and from the castration anxiety linked to such a position (cf. Malcapaine and Hunter; Urtubey).

ROGER PERRON

See also: Castration complex; Neurosis; “Psycho-Analytic Notes on an Autobiographical Account of a Case of Paranoia (Dementia Paranoides).”

### Source Citation

Freud, Sigmund. (1923d [1922]) Eine Teufels-neurose im siebzehnten Jahrhundert. *Imago* 9, 1–34; *GW*, XIII, 317–53; A seventeenth-century demonological neurosis. *SE*, 19, 72–105.

### Bibliography

Macalpine, Ida, and Hunter, Richard. *Schizophrenia 1677*. London: William Dawson: 1956.

Urtubey, Luisa de. *Freud et le Diable*. Paris: Presses Universitaires de France, 1983.

## SEX AND CHARACTER

Otto Weininger began to draft *Sex and Character* in 1900, at the time when Hermann Swoboda informed him of Freud’s interpretation of bisexuality, and the book was elaborated concurrently with an exchange of ideas between the two friends. In 1901, having registered his manuscript, then called *Eros and Psyche*, in order to preserve his intellectual property rights, he wished to have it published and to this end this he met with Freud who took an unfavorable view of it. In 1902 Weininger successfully presented his reworked manuscript for his doctoral thesis in philosophy. He converted to Protestantism and then presented a third version of the book, which was characterized by the addition of chapters on Jews and women and the fact that he extended the metaphysical system.

First published in 1903 by a major publisher, Braumüller, the book became a bestseller after its author’s suicide. It ran to twenty-eight editions between 1903 and 1947 and was translated into ten languages. Many articles in *The Torch* (*Die Fackel*) contributed to the success of the book, as did accusations of plagiarism, by Paul J. Moebius in 1904 and most of all by Otto Fliess in 1906. Otto Rank was convinced by the work, each of its arguments reflecting his personal experience: “They were even expressed in my own terms,” he said. In a footnote to Herbert Graf’s (“Little Hans”) analysis, Freud wrote that “Being a neurotic, Weininger was completely under the sway of his infantile complexes; and from that standpoint what is common

to Jews and women is their relation to the castration complex" (1909b, p. 36).

Although consisting of multiple philosophical digressions, Weininger's book does in fact revolve around a central question that brings it closer to psychoanalytic research, the impossibility of establishing a definite group relation between the sexes. For Weininger there were two ideal types, M and F, which are analogous to Platonic types. Real individuals were intermediary bisexual states, defined by their proportions of M and F. There was no break in nature between masculine and feminine but a bisexual structure in varied proportions which, because of psycho-physiological parallelism, involved both the microscopic body and the mind. This Male/Female mosaic explains sexual attraction, which seeks to achieve complementarity: a man with the equation  $3/4M+1/4F$  seeks a woman with the equation  $3/4F+1/4M$ . It thus transpires that the ideal relation would be between a homosexual man and a homosexual woman. However, men and women who are attracted to each other are corporally individuated; they are not types. Weininger realized that: "In spite of the infinite gradation of the intermediary forms, the human being is definitively either man or woman," but diverges from the point when he postulates a substance that he used as the basis of his characterology. The permanent confusion between the outline of substantialized types and empirical experience gives his statements about women a shocking character—"The absolute female has no ego" (p. 186). The same holds true for his comments on Jews, whom he compares to women, speaking of Judaism as a "Platonic idea" (p. 311). For this reason he sometimes has to explain that he does not wish to "lend the faintest support to any practical or theoretical persecution of Jews" (p. 311). Jewish himself, Weininger's thesis is a testament to what he calls "self hatred."

ERIK PORGE

*See also:* Bisexuality; Fliess, Wilhelm; Self-Hatred; Swoboda, Hermann; Weininger, Otto.

### Source Citation

Weininger Otto. (1908). *Geschlecht und Charakter*. London: Heinemann. (Original work published 1903)

### Bibliography

Freud, Sigmund. (1909b). Analysis of a phobia in a five-year-old boy. *SE*, 10: 1–149.

Le Rider, Jacques. (1982). *Le cas Otto Weininger*. Paris: P.U.F.

———. (1990). *Modernité viennoise et crises de l'identité*. Paris: P.U.F.

Porte, Erik. (1994). *Vol d'idées?* Paris: Denoël.

Rodlauer, Hannelore. (1990). *Otto Weiningers Eros und Psyche*. Vienna: Österreich Akademie der Wissenschaften.

---

## SEXUAL DIFFERENCE

Sexual difference refers to recognition by the child of the difference of the sexes. This recognition is related to the Oedipus complex and the castration complex.

In 1908 (1908c) Sigmund Freud presented for the first time the notion of the castration complex, centered on fantasies of castration and closely linked to the drives. Through this complex, whose framework is the "theory of infantile sexuality," the child is able to acknowledge sexual difference. In the same text Freud indicated that before the question of castration becomes important for the child, the child is capable, through the use of external signs, of making a (gender) distinction between men and women. Of its own initiative, the child will develop a sense of gender identity—male or female. This distinction is not dependent on the drives or the genitals. It is only with the "primacy of the phallus" (1923e) that the genital organ will be taken into account for both sexes, based on the presence or absence of the male genital organ. It is this awareness that leads to the question of castration. Moreover, it is through identification with the father and mother during the oedipal period that the child acquires the symbolic cues for masculine and feminine, whose dynamic will not be completed until adolescence. At that time, the material reality of the penis-vagina duality will replace the apparent reality of the phallus-missing phallus duality.

By separating penis and phallus and emphasizing symbolic castration, an operation through which the subject is formed, Jacques Lacan provides a very different interpretation for the castration complex, which now becomes dependent on phallic logic. If human sexuality is immediately subverted by language and if "the imaginary function of the phallus completes the challenge to sexuality through the castration complex in both sexes" (1958), then understanding what differentiates the sexes becomes problematic. Lacan then developed his idea of sexuation—a term borrowed from biology—to show the subject's modes of inscription in

the phallic function. This refers to the way in which both sexes recognize and differentiate themselves in the unconscious.

Since Freud recognized that his description related only to boys and for Lacan the relation to the phallus “was established without regard for the anatomical difference of the sexes,” we are led to the conclusion that psychoanalytic theory on sexual difference and, in particular, on what a woman is, remains highly incomplete.

Finally, it is important to point out that sexual difference, which enables the subject to relate to its own anatomical sex and position itself as man or woman, introduces important questions in psychoanalysis, as important as the problematic of identification/identity.

PAULO R. CECCARELLI

*See also:* Gender identity; Oedipus complex; Phallus; Sexuality.

### **Bibliography**

Freud, Sigmund. (1908c). On the sexual theories of children. *SE*, 9: 205–226.

———. (1923e). The infantile genital organization (An interpolation into the theory of sexuality). *SE*, 19: 141–145.

Lacan, Jacques. (1966). La signification du phallus (Die Bedeutung des Phallus). *Écrits*, 685–695. Paris: Le Seuil. (Original work published 1958)

## **SEXUAL DRIVE**

“... The sexual [drive] does not originally serve the purposes of reproduction at all, but has as its aim the gaining of particular kinds of pleasure. It manifests itself in this way in human infancy, during which it attains its aim of gaining pleasure not only from the genitals but from other parts of the body (the erotogenic zones)... We call this stage the stage of auto-erotism... The development of the sexual [drive] then proceeds from auto-erotism to object-love and from the autonomy of the erotogenic zones to their subordination under the primacy of the genitals which are put at the service of reproduction” (Freud, 1908d, p. 188). The psychoanalytic movement is a revolution of “The sexual [drive]—or more correctly, the sexual

[drives], for analytic investigation teaches us that the sexual [drive] is made up of many separate constituents or component [drives]” (p. 187).

Thus Freud dissociated reproduction and sexuality. The innate sexual drive appears in earliest infancy. Its composite origin accounts for its perverse, neurotic, and normal adult manifestations, which appear in a vast synthesis. The importance of its dynamic manifestations in the psyche is well recognized in the form of libido, which is the fixed point in psychic conflict. The libido is opposed first to the drives of self-preservation or the ego drives, and then to the death drive. In this latter case, the libido goes under the name of “life drives” or Eros.

The term *Geschlechtstrieb* (sexual drive) appeared in 1894, at the same time as “libido” (1895b [1894]). In 1895, Freud published a review of a lecture entitled, “Der Geschlechtstrieb,” and denounced the underestimation of the sexual drive (1895i). He noted the importance of sexuality in the etiology of the neuroses and referred to “the participation of sexual motive forces as an indispensable premise” (1896c, p. 200). The discovery of infantile sexuality and its synthesis with the diversity of adult sexual life was announced in 1905 in the *Three Essays on the Theory of Sexuality* (1905d).

The *Three Essays* can be credited with “enlarging the concept of sexuality” (1905d, p. 134). Insofar as it is supported by all the other vital functions, the sexual drive in infancy is perverse, ubiquitous, and a composite of partial drives. Education and the development of the ego are able to modify the sexual drive: with no predetermined object it is entirely plastic, except for fixation. When its energy is deflected, libido can be invested in the interests of the ego and of culture. This view of the sexual drives (though disturbing) accounted for the essentials of psychic energy with repression playing a central role and is to be modified through the next two steps. Libidinal investment in the ego makes its appearance as an original contribution, necessary and essential to the sexual drive for survival. And then it is only the sexual drives that have the power to stand against the death drive.

As the very paradigm of the drive, the sexual drive is so central that there could be no conception of psychoanalysis without it. As Freud stated at the time of his break with Carl Jung in 1913, to dispute the importance of the sexual drive is tantamount to rejecting psychoanalysis.

MICHÈLE PORTE



*See also:* Adolescence; Anaclisis/anaclitic; Anxiety; Desexualization; Dipsomania; Drive/instinct; Ego-libido/object-libido; Eroticism, anal; Eroticism, oral; Libido; Lost object; Oral stage; Otherness; Pleasure ego/reality ego; Psychogenic blindness; Puberty; Reciprocal paths of influence (libidinal coexcitation); Sexuality; Symbol; Transference/counter-transference (analytical psychology); Work (as a psychoanalytical notion).

### **Bibliography**

- Freud, Sigmund. (1896c). The aetiology of hysteria. *SE*, 3: 186–221.
- . (1908d). “Civilized” sexual morality and modern nervous illness. *SE*, 9: 177–204.
- . (1895b [1894]). On the grounds for detaching a particular syndrome from neurasthenia under the description “anxiety neurosis.” *SE*, 3: 85–115.
- . (1895i). Rezension von: Hegar, Alfred, *Der Geschlechtstrieb. Eine social-medicinische Studie*. In *Wiener klin. Rdsch.*, 9 (1895): 77.
- . (1905d). *Three essays on the theory of sexuality*. *SE*, 7: 123–245.

---

## **“SEXUAL ENLIGHTENMENT OF CHILDREN, THE”**

This short text by Freud was written in the form of an open letter addressed to Dr. Fürst for publication in a journal on social medicine and hygiene. “The Sexual Enlightenment of Children” is contemporaneous with the *Three Essays on Sexuality* (1905d) and “Little Hans” (1909b), in both of which this same question of infantile sexual curiosity is developed. However, in this essay Freud discusses the ethical and epidemiological (with regard to the prevention of neuroses) aspects of a question he will examine from a more relativist perspective thirty years later in “Analysis Terminable and Interminable” (1937c).

Freud’s question has three components: “Can we, in general, supply explanations to children about sexual activity? At what age and how?” Freud strongly rejects the relevance of the first question, arguing that any possible refusal will only lead the child to obtain the withheld information from a different source and consider sexuality as something dirty. His principal argument is related to the existence of infantile sexuality as revealed in the *Three Essays* and he concludes that “refusal” only deprives the child of the ability to

intellectually overcome the exploits for which he is psychically prepared and somatically ‘adjusted’ except with respect to reproduction.”

Freud addressed the two major problems that preoccupy the child: the difference between the sexes and the origin of children, and he refers to infantile sexual theories, which are first discussed in a short essay that would be published later on (“On the Sexual Theories of Children,” 1908c). He concluded with these words: “What is most important is that children never develop the idea that we prefer to hide from them the facts of sexual life rather than other facts that are not yet accessible to their understanding.” The question of how to express this is resolved in the suggestion of adapting knowledge of sexual matters to knowledge of animal life in general, depending on the age and aptitude of the child.

This short essay is a precious example of how concepts in ethics and pedagogy can be spontaneously generated by the process of psychoanalytic discovery.

SOPHIE DE MIJOLLA-MELLOR

*See also:* Sexual theories of children; Technique with children, psychoanalytic.

### **Source Citation**

- Freud, Sigmund. (1907c). Zur sexuellen Aufklärung der Kinder (Offener Brief an Dr M. Fürst). *Soz. Med. Hyg.*, 2, 360–367; *GW*, 7, 19–27; The sexual enlightenment of children. *SE*, 9: 131–139.

---

## **SEXUAL THEORIES OF CHILDREN**

In Freud’s view, children’s sexual theories arise neither in response to “some inborn need for established causality” nor out of an interest in sex that assumes a theoretical dimension. Rather, they are the product of a life need (*Lebensnot*) that encourages the child to master in thought, and perhaps even to avert, the feared arrival in the family of a new, younger sibling with whom the parents’ love will have to be shared.

Such theories seek to explain the differences between the sexes and the origins of sexual relations. Three aspects may be considered for each theory: its content, the modalities of its development, and the sexual (not theoretical) cathexis that the child can thereby mobilize. In this last aspect, the child’s sexual

theories closely resemble fantasies in that they are largely excluded from the demands of critical reasoning. Freud describes children's sexual theories as the direct expression, uninhibited and untransformed, of infantile sexual component instincts. This explains why children can maintain "accurate" theories, imparted by adults, alongside their own, for which they have a preference of an instinctual kind. "For a long time after they have been given sexual enlightenment [children] behave like primitive races who have had Christianity thrust upon them and who continue to worship their old idols in secret" (Freud, 1937c, p. 234).

More generally, the sexual fantasies of adults, especially masturbatory fantasies, may be looked upon as remnants of childhood theories. They are never abstract, for they are accompanied by a sexual excitement that supports the ideational content.

The sexual cathexis of a "theoretical" realm offers the best possible example of the origin of the sublimating function, which makes possible a diversion of sexual excitation to a theoretical activity dissociated from sexual questions (investigation and the invention of answers to riddles). This process, however, may be eliminated, impeded (as in inhibition), or aborted (as in obsessional rumination). According to Freud, the construction of childhood sexual theories is based on information provided by adults and other children and also on the sensations of the child's own body that accompany the work of thinking: "If children could follow the hints given by the excitation of the penis they would get a little nearer to the solution of their problem" (Freud, 1905d, p. 218). Observation of the animal world can also be a source of "exact" knowledge and the basis of projections, as with "little Hans" and the horse (Freud, 1909b).

It is fair to say, even though Freud does not theorize matters thus, that the case history of little Hans reveals the role of language in how children work out their theories. Before it is possible to speak of a theory, and not merely of a fantasy, what is being represented must be capable of attaching itself to words. If in general the naming of affects always falls short of reality, this is especially flagrant when a child has to relate direct experience as murky and violent as that associated with the primal scene (adults engaged in sex) or birth. So the child sets up a divide: the child reacts to experience by either abdicating or else relentlessly pursuing a quest for a theory that no

setback can stop, since it merely supplies another motive for research.

The content of childhood sexual theories, as described by Freud, is confined to a few typical ideas that can also be found in folklore and that constitute the basis of complexes (as for example the castration complex). However, the subject matter of these theories is just as varied as the content of ordinary fantasies (as distinct from primal fantasies). The content depends on whatever elements the child happens to come across: magical words, formulas, distorted words given a sexual meaning by the child (like the phrase "horse way" for Little Hans), or obscenities (Ferenczi, 1910).

At first sight, the term "sexual theories" might seem open to objection, but the great utility of the notion has been demonstrated by the link it makes between abstract theorizing and the sexual origins of such theorizing. These theories are clearly marked by a childish manner of thinking, a cumulative logic in which one causal explanation can be superimposed upon another without creating any contradiction overall. The child's research does not proceed by making use of known elements in order to master other, unknown elements, which is the usual form of the theoretical approach; instead, the child collects heterogeneous clues, because one mystery may stand for another and can therefore be conjoined with it (Mijolla-Mellor, 1999).

SOPHIE DE MIJOLLA-MELLOR

*See also:* Infantile sexual curiosity; Family romance; Feces; Historical reality; Knowledge or research, instinct for; Modesty; Pregnancy, fantasy of; Primal scene; Psychic revision; "Sexual Enlightenment Of Children, The"; *Trauma of Birth, The*; "Vagina dentata," fantasy of.

### **Bibliography**

- Freud, Sigmund. (1905d). Three essays on the theory of sexuality. *SE*, 7: 123–243.
- . (1908c). On the sexual theories of children. *SE*, 9: 205–226.
- . (1909b). Analysis of a phobia in a five-year-old boy. *SE*, 10: 1–149.
- . (1918b [1914]). From the history of an infantile neurosis. *SE*, 17: 1–122.
- . (1937c). Analysis terminable and interminable. *SE*, 23: 209–253.

Mijolla-Mellor, Sophie de. (1996). Le meurtre comme théorie sexuelle infantile. *Topique*, 59, 15–29.

———. (1999). Les mythes magico-sexuels autour de l'origine et de la fin. *Topique*, 68, 19–32.

### Further Reading

Maldonado, J.L. (1998). Panel: Childhood sexual theories and childhood sexuality. *International Journal of Psychoanalysis*, 79, 148–151.

## SEXUAL TRAUMA

The term *sexual trauma* refers to a sexual situation that causes intense fear because the subject, a child, is exposed to it in a state of passivity and unpreparedness.

Classical psychiatry was already interested in traumas when Freud was developing his ideas. He borrowed the term, but replaced the psychiatric notion of a shock from a serious accident causing a fear of death with that of the impact of sexual aggressions against children. In a letter of October 15, 1895, he wrote to Wilhelm Fliess: “Have I revealed the great clinical secret to you?... Hysteria is the consequence of a presexual *sexual shock*” (1954a [1887–1902], p. 127). The notion of sexual trauma was here implicitly evoked for the first time; it would play a fundamental role in the history of psychoanalysis.

In the early days of his practice, Freud concluded from the frequency with which his patients recounted sexual scenes that such adult seductions of children were real, and that psychical traumas were always sexual in nature. Based on these clinical observations, Freud developed a theory, in 1895–1897, of the two-step effect of the trauma. According to this view, an initial event left traces that would be awakened a later time, usually at puberty, and lead to a flooding of the psyche with libidinal energy and a corresponding generation of anxiety.

With the discovery of infantile sexuality (1905d), Freud realized that scenes of seduction were often fantasy reconstructions; nevertheless, despite the abandonment of what he called his “*neurotica*,” he never stopped worrying about the question of just how fictitious and how real such scenes were. What was traumatizing in Freud’s view was not the event per se but the affects and representations, including fantasies, to which it gave rise. Its impact was a function of the

time it occurred relative to the child’s ego development and ability to metabolize the excitation thus initiated and relative to the effects it had on the child’s fantasy organization. For a trauma to be represented on an inner stage, and in more than one phase—and so to “offer by far the more favorable field for analysis” (Freud, 1937c, p. 220)—it must be neither premature nor too strong.

Sexual trauma, as defined by Freud in his first topography, cannot be understood independently of the notions of seduction, repression, deferred action, and internal versus external reality. At this phase of his thinking Freud did not yet consider the narcissistic injury caused by such traumas. And in his concern to locate scenes of seduction at an ever earlier date and to study their much later pathological effects—a concern that necessarily put the spotlight on the mechanism of deferred action—he paid scant attention to sexual aggressions suffered in adulthood or to their traumatic effects.

FRANÇOISE BRETTE

*See also:* “Confusion of Tongues between Adults and the Child”; “Heredity and the Etiology of the Neuroses”; Hysteria; Memories; Neurotica; Seduction scenes; Trauma.

### Bibliography

Freud, Sigmund. (1905d). Three essays on the theory of sexuality. *SE*, 7: 123–243.

———. (1937c). Analysis terminable and interminable. *SE*, 23: 209–253.

———. (1939a). Moses and monotheism. *SE*, 23: 1–137.

———. (1954a [1887–1902]). *The origins of psycho-analysis: Letters to Wilhelm Fliess, drafts and notes, 1887–1902* (Marie Bonaparte et al., Eds.; Eric Mosbacher and James Strachey, Trans.). London: Imago.

Freud, Sigmund, and Breuer, Josef. (1895d). Studies on hysteria. *SE*, 2: 48–106.

### Further Reading

Levine, Howard (Ed.). (1990). *Adult analysis and childhood sexual abuse*. Hillsdale, NJ: Analytic Press.

Scharff, Jill S., and Scharff, David E. (1994). *Object relations therapy of physical and sexual trauma*. Northvale, NJ: Aronson, Inc.

Shengold, Leonard. (1989). *Soul murder: The effects of childhood abuse and deprivation*. New Haven: Yale University Press.

## SEXUALITY

Sexuality as understood by Sigmund Freud is “psycho-sexuality,” and should be taken “in the same comprehensive sense as that in which the German language uses the word ‘*lieben*’ (to love).” (1910k, pp. 222–23)

In his clinical work during the closing years of the nineteenth century, Freud noticed how significant a role sexuality played in the mental conflicts of his patients, eventually concluding that it was invariably one of the poles of any symptom-generating conflict. In *The Interpretation of Dreams* (1900a), he evoked the importance of childhood sexuality solely in connection with neurotics, but beginning with the first edition of the *Three Essays on the Theory of Sexuality* (1905d) he asserted its presence and its essential role in all children. Thereafter Freud conceived of human sexuality in a broadened sense that included childhood and perverse sexuality. Childhood sexuality had three main characteristics: it was autoerotic, subject to the primacy of erotogenic zones and component instincts, and anaclitically dependent on the self-preservation instincts or ego-instincts.

It would take twenty or so years for Freud to arrive at the theory of the four stages of psychosexual development that we now find in the manuals. Each stage was characterized by the dominance of a different erotogenic zone: oral, anal, phallic, genital. The child was polymorphously perverse in that the primacy of the genital zone and of the relationship to the object was not yet established. The pervert remained fixated in, or regressed to, a subordination to one or other of the non-genital zones, ruled by component instincts. Despite this broadening of the concept of sexuality, Freud continued to define a so-called normal sexuality, reached at the end-point of development and characterized by the primacy of the genital zone and of the relationship to the object. But he had trouble completely detaching normal sexuality from the goal of procreation, something he had been able to do in the cases of infantile and perverse sexuality (see the twentieth of the *Introductory Lectures* [1916–17a]).

Another point, often insufficiently stressed, is the distinction Freud drew between two currents, the affectionate and the sensual, “whose union is necessary

to ensure a completely normal attitude in love” (1912d, p. 180).

The whole of childhood sexuality falls under the rubric of the “Oedipus complex,” a term first used by Freud in “A Special Type of Choice of Object Made by Men” (1910h, p. 171), even though he had referred to Sophocles’ *Oedipus Rex* as early as 1897 in a letter to Fliess. The Oedipus complex was at first presented by Freud from the young boy’s point of view, and in a simplified form: the little boy is in love with his mother and so becomes his father’s rival. In the complete form, bisexuality came into play: the boy also wants to take his mother’s place vis-à-vis his father (inverted Oedipus complex). The Oedipus complex of the girl was not in Freud’s view symmetrical with that of the boy, for the girl did not experience the tragic conjunction of love for the mother and a rivalry with the father provoking murderous wishes.

A sexuality that could be called perverse inasmuch it activated erotogenic zones other than the genital nevertheless had a place in normal sexuality in the shape of “fore-pleasure.” What characterized perverse sexuality proper was the rigidity and exclusiveness of the manner of achieving orgasm.

Until 1920 Freud described mental conflict as a clash between the sexual instincts and the self-preserved instincts, also known as ego-instincts. Beginning with *Beyond the Pleasure Principle* (1920g), however, a new opposition came to the fore in Freud’s thinking, though without eradicating the earlier: that between Eros (life instincts or sexual instincts) and Thanatos (death instincts). This was yet another broadening of the concept of sexuality: Eros—love—sought to hold things together, while Thanatos—death—strove to tear them apart and destroy them. As noted above, Freud gave sexuality the same extension as the verb “to love”; since one side of the conflict is always sexuality, it may reasonably be deduced that all mental disturbance has a connection with sexuality conceived as love, as a tie to an object.

Freud was accused by some of “pansexualism.” It is true that sexuality was present everywhere in his theory, yet it was always seen as in conflict with other instinctual forces, so that Freud was surely right to defend himself against this charge.

On the other hand, the issue of the relationship between sexual disturbances and psychopathology is not simple. It is quite possible to encounter dysfunctional

sexuality in the strict sense in a person who presents no particular mental symptoms in other areas, while a perfectly satisfactory orgasm may occur in otherwise deeply disturbed individuals. But the libidinal tie and the relationship to the object are always implicated in the organization of the personality and in mental pathology. In psychoanalytic treatment, the transference instates a relationship of libidinal dependence with the analyst that repeats the relationship with parental figures. The transference—the motor of psychoanalysis—may become an obstacle to treatment if it takes a totally eroticized form.

For Freud, then, human sexuality was psychosexual, and individual and cultural ideas played an important role therein; yet in his view it was also biological, and he was certainly not mistaken in this. The object of the instinct is not given with the instinct itself. The history of the individual, which is to say the history of that individual's relationships with his mother, father, and other key people in the entourage, contributes to the constitution of his particular sexuality. Freud wrote that the infant's relationship with the mother who gave it the breast supplied the prototype for the adult's later love relationships. Weaning brought about the loss of the breast as libidinal object, and thereafter the individual would seek to rediscover that lost object. But some infants are not breast-fed, in which case weaning will not have the same character, and may not be so late. The breast has become a metaphor for all bodily attentions from the mother (Donald W. Winnicott), or else as a part-object (Melanie Klein). In language, and for the infant—even an infant which has not been breast-fed—the breast symbolizes the mother, and is an object of desire. Freud seems never to have heard little boys crying because they cannot have breasts like their mother, and he retained only the little girl's penis envy as a mark of the child's confrontation with the anatomical difference between the sexes. Freud's patriarchal and phallogocentric assumptions echo his culture, and he was unaware of them. Only rarely do we now see the typical neuroses and disturbances of sexuality that Freud described in his "Contributions to the Psychology of Love" (1910h, 1912d); and when we do, patients usually come from families where they have received a traditional patriarchal upbringing.

Freud never suggested that unbridled sexual activity could remedy sexual and mental problems. Certainly, he at first emphasized the conflict between sexual

wishes and the external world, and made "civilized sexual morality" responsible for "modern nervous illness." (1908d). But later on he located the essential conflict—that between the forces of binding and the forces of unbinding—within the psyche. A strong superego, constituted by means of identification with the father as prohibitor of incest—and also (as something of an afterthought on Freud's part) by the mother—he judged necessary not only to morality but also to creativity, to sublimation, that is to say to the inhibition and diversion of strictly sexual instinctual aims. Libido seemed to Freud to be masculine in essence, and he considered the woman's superego—and hence her moral sense and creativity—to be weaker than the man's. Women were destined to passivity, or at least to activities with passive aims. Freud rejected feminist aspirations to equality between men and women.

COLETTE CHILAND

*See also:* Bisexuality; Death instinct (Thanatos); Female sexuality; Heterosexuality; Homosexuality; Life instinct (Eros).

### **Bibliography**

- Freud, Sigmund. (1900a). The interpretation of dreams. *SE*, 4–5.
- . (1905d). Three essays on the theory of sexuality. *SE*, 7.
- . (1908d). "Civilized" sexual morality and modern nervous illness. *SE*, 9.
- . (1910h). A special type of choice of object made by men (contributions to the psychology of love I). *SE*, 11.
- . (1910k). "Wild" psycho-analysis. *SE*, 11.
- . (1912d). On the universal tendency to debasement in the sphere of love (contributions to the psychology of love II). *SE*, 11.
- . (1916–17a). Introductory lectures on psycho-analysis. *SE*, 15–16.
- . (1920g). Beyond the pleasure principle. *SE*, 18.

### **Further Reading**

- Chodorow, Nancy. (1989). *Feminism and psychoanalytic theory*. New Haven: Yale University Press.

Friedman, Robert. (2001). Psychoanalysis and human sexuality. *Journal of the American Psychoanalytic Association*, 49, 1115–1132.

Kulish, Nancy. (2002). Female sexuality: Pleasure of secrets and the secret of pleasure. *Psychoanalytic Study of the Child*, 57, 151–176.

## SEXUALIZATION

Heinz Kohut has a view of sexualization that differs from Freud's. In fact, he sees it not so much as a defensive structure, but rather as the indication of a structural deficit. From the point of view of the drives, this deficit appears as an insufficient neutralization. From the point of view of the Selfobject [SIC], one might say that there is a lack of a necessary relation with another source of responsiveness. There is another idea involved, too: it is possible to attenuate or to dissipate sexualization by establishing a Selfobject transference. Independently of the theoretical perspective, sexualization becomes, in practice, an activity that imbues the whole personality and contributes, in an episodic or regular way, to the maintenance of psychological equilibrium. It procures pleasure and helps to obliterate painful feelings. It can also help to stem regression and enable the establishment of a relation that, while it may appear infantile, still helps to develop the Self's cohesion. Given all the psychological gains that it implies, it often resists analytical intervention without the elaboration and working-through of a Selfobject transference.

The way the diverse forms of sexualization are considered consists in translating behavior into a narrative that represents individual psychodynamics. Thus the exhibitionist or the pedophile is expressing a specific psychological configuration that can be read as a manifest content. This is most probably an exaggerated simplification, since many forms of sexualization are more a matter of fortuitous circumstances, or even of biology, than of psychological meaning. Sexualization is essentially perpetuated by vertical splitting. Any treatment of difficulties involving sexualization needs to study this particular structural problem.

ARNOLD GOLDBERG

See also: Self-object; Splitting, vertical and horizontal.

### Bibliography

Goldberg, Arnold. (1995). *The problem of perversion*. (p. 29–45, 64–79). New Haven: Yale University Press.

Kohut, Heinz. (1971). *The analysis of the self*. New York: International Universities Press.

## SEXUATION, FORMULAS OF

According to Jacques Lacan, *sexuation*, as distinct from biological sexuality, designates the way in which the subject is inscribed in the difference between the sexes, specifically in terms of the unconscious and castration, that is, as “inhabiting language” (Lacan, 1998, p. 80).

Lacan presented the complete table of the formulas of sexuation on March 13, 1973, during one of the lectures of his seminar *Encore* (1972–1973), but as early as 1971 he began to use his own symbols for the logical quantifiers and the function  $\Phi x$  (figure 1).

Lacan's choice of the term *sexuation*, and not *sexuality*, indicates that being recognized as a man or woman is a matter of the signifier.

The phallus is situated as a symbol, the signifier of castration and thus also of desire. The Law that is transmitted by the father and that states the prohibition against incest is also the foundation of desire. And this is the Law of castration, which Lacan designated in his graph as the phallic function,  $\Phi x$ .

To construct these formulas, Lacan relied on the Aristotelian logic according to which propositions are categorized in four classes: the universal affirmative, the universal negative, the particular affirmative, and the particular negative. But Lacan adopted modern symbols for these categories, which are based on the universal quantifier,  $\forall$ , and the existential quantifier,  $\exists$ .

On the left side of the table, there appears the formula  $\forall x \Phi x$ , for all  $x$   $\Phi$  of  $x$  (all men are submitted to the phallic function, that is, castration). But modern logic has demonstrated the necessity of a particular negative,  $\exists x \neg \Phi x$  (there exists at least one that is not submitted to the phallic function), in order to found the universal affirmative. This is the hypothesis that Sigmund Freud developed in his myth of the primal father in *Totem and Taboo* (1912–1913a), and also in his argument that Moses was not a Jew in *Moses and Monotheism* (1939a): there always exists one who is an exception. This is how man is inscribed: by the phallic function, but on the condition that this function “is limited due to the existence of an  $x$  by which the function  $\Phi x$  is negated” (Lacan, p. 79). This is the function of the father.

The other side of the table concerns the “woman portion of speaking beings” (p. 80). The upper line is

FIGURE 1

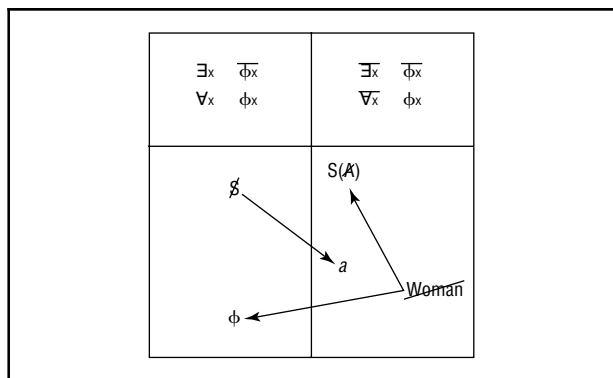

read as follows: there does not exist any  $x$  that does not fall under the phallic function. In other words, castration functions for all women. But on the lower line Lacan introduced a negation marked by the barring of the universal quantifier, which is quite inconceivable from the perspective of formal logic. Lacan proposed that it be read as “not-whole.”

The woman’s side of the table “will not allow for any universality” (p. 80). Woman is not wholly within the phallic function. On this side there is no exception that could serve as the basis for a set of women. It is from this fact that Lacan derived the formula, “Woman doesn’t exist.” This formula leaves no room for any idea of an “essence” of femininity.

Below the table of formulas, there is a “scanded indication of what is in question” (p. 80). On the masculine side, there is the barred subject “and the  $\Phi$  that props him up as signifier” (p. 80). For the male is only able to reach his partner, the Other, through castration and the mediation of the object  $a$  as its effect. This is indicated by the arrow that crosses from the male side to the female side, which also reproduces the Lacanian formula of fantasy. On the feminine side, woman is doubled: she has a relation with  $\Phi$ , insofar as a man incarnates it for her. But she is not wholly in that relation. She also has a relation to the signifier of  $A$ , the signifier that the Other would need if a set of women were going to be formed. Woman’s jouissance is thus divided between phallic jouissance, linked to castration and appearing on the graph as  $\Phi$ , and an Other jouissance that is unique to her. Thus there is neither symmetry between the two sides of the table, nor any complementarity between the sexes.

ALAN VANIER

See also: Graph of Desire; Jouissance (Lacan); Matheme; Phallus; Sex differences.

## Bibliography

- Lacan, Jacques. (1970–1971). *Le séminaire-livre XVIII, d’un discours qui ne serait pas du semblant*. [On a discourse that might not be a semblance] (unpublished seminar).
- . (1971–1972). *Le séminaire-livre XIX, . . . ou pire [. . . or worse]*. (unpublished seminar).
- . (1998). *The seminar of Jacques Lacan, book XX, on feminine sexuality: The limits of love and knowledge, encore*. (Bruce Fink, Trans.) New York: Norton. (Original work published 1972–1973)

## SHADOW (ANALYTICAL PSYCHOLOGY)

In Carl Gustav Jung’s analytical psychology, the shadow as a concept comprises everything the conscious personality experiences as negative. In dreams and fantasies the shadow appears with the characteristics of a personality of the same sex as the ego, but in a very different configuration. It is presented as the eternal antagonist of an individual or group, or the dark brother within, who always accompanies one, the way Mephistopheles accompanied Goethe’s Faust.

The role of the shadow within is sometimes hidden, and sometimes rejected or repressed, by the conscious ego. In the latter case it is pushed into the unconscious, where, because of its energy, it acts as a complex. People can, for example, be fully aware that they are avaricious, greedy, or aggressive and still manage to hide these truths from others beneath the mask of the *persona*. But they can also repress those characteristics. Then they are no longer conscious of them at all, and their moral ego is reestablished.

The shadow in everyone varies considerably depending on the guidelines in force within the family, the community, and the culture in which they grow up. Moreover, the shadow is not only made up of aspects of personality experienced as disagreeable or negative, but it can also have a positive side.

When the shadow is not integrated into the conscious personality and remains unconscious, it can manifest itself in two different forms. On the one hand, it can project itself onto another person in one’s immediate or distant circle, leading to serious conflicts among siblings, couples, or colleagues that have a tendency to recur and lead to lasting misunderstandings. On the other hand, it can also cause deflation, so that those involved find themselves subjugated and thus inferior, bad, or clumsy. In fact, the shadow corre-

sponds to what one does not want to become but still is, within the self. It is even something necessary, for just as a painting needs shadow to give it life and depth, each human needs a shadow—as illustrated by Peter Schlemihl de Chamisso (1824)—to become a true human being with all the genuine weaknesses and defects, qualities which can even make them likeable.

Jung developed and enriched the concept of the shadow throughout the 1930s, when he began studying closely alchemical literature and iconography in relation to his experience and conception of the process of individuation. He compared the “black work” of the alchemists (the *nigredo*) with the often highly critical involvement experienced by the ego, until it accepts the new equilibrium brought about by the creation of the self.

In the work he did after World War II, Jung developed the distinction between the personal shadow and the collective shadow, emphasizing the fact that while recognition and analysis of the shadow lead to a confrontation with the drives and the most intimate representations, they also lead to a confrontation with the collective unconscious. It is this that gives rise to projections of the shadow onto other cultures, other peoples, and other races—something that occurred during the twentieth century to an alarming extent.

HANS DIECKMANN

*See also:* Analytical psychology; Collective unconscious (analytical psychology); Ego (analytical psychology); Jung, Carl Gustav; Projection and “mystical participation” (analytical psychology).

### **Bibliography**

- Jung, Carl Gustav. (1921). Psychological types. *Collected works*, v. 6. Princeton: Princeton University Press (Bollingen Series).
- . (1928d). Instinct and the unconscious. *Collected works*, v. 8. Princeton: Princeton University Press (Bollingen Series).
- . (1944). Psychology and alchemy. *Collected works*, v. 12. Princeton: Princeton University Press (Bollingen Series).
- . (1951). Aion: researches into the phenomenology of the self. *Collected works*, v. 9. Princeton: Princeton University Press (Bollingen Series).
- . (1955–1956). *Mysterium conjunctionis: an inquiry into the separation and synthesis of psychic opposites in*

alchemy. *Collected works*, v. 14. Princeton: Princeton University Press (Bollingen Series).

## **SHAKESPEARE AND PSYCHOANALYSIS**

Throughout the century, psychoanalysts have studied Shakespeare’s works to deepen their understanding of psychic conflict and to hone their interpretive skills. Literary scholars have turned to psychoanalysis to solve perennial problems in interpreting Shakespeare’s text.

In a letter to his friend Wilhelm Fliess (15 October, 1897), Sigmund Freud sketched out his first formulation of what he would come to call the Oedipus complex, then promptly went on to show how this notion could be used to interpret some notorious cruxes in *Hamlet*. Freud linked, through the triangular structure of the Oedipus complex, Hamlet’s hesitation to avenge his father, his pangs of conscience, his hostility to Ophelia, the sexual disgust expressed to Gertrude, and his final destruction (1900a, 4: 264–266). “There are more things in heaven and earth Horatio, than are dreamt of in your philosophy” (1910c, 11: 137n.): Freud’s favorite quotation from any source, according to Jones, was this tribute to the complexity of existence, from *Hamlet*.

The nature of Freud’s attachment to Shakespeare’s work is also conveyed in his association of a “special cadence” in his own dream speech, with a cadence in Brutus’s speech of self-justification in *Julius Caesar*. “As Caesar loved me, I weep for him; as he was fortunate, I rejoice at it; as he was valiant, I honor him; but, as he was ambitious, I slew him.” (1900a, 5: 424) Freud shed light on the unconscious conflict over gender and ambition that fractured Lady Macbeth’s psyche, and on Shakespeare’s technique of splitting a character in two “she becomes all remorse and he all defiance” (1916d, 14: 324).

In Shakespeare criticism, after classic papers by Ludwig Jekels, Ernest Jones, Theodor Reik, Hanns Sachs, Wangh (Faber, M., 1970) and others, there has been a proliferation of essays, applying various aspects of psychoanalytic theory to Shakespeare’s texts: dream theory, the structural model, incest fantasies, primal scene fantasies, and the symbolizing and creative functions of the psyche itself. There are several English bibliographies that catalogue these works, including those by Norman Holland (1964), D. Wilbern (1978), and Murray Schwartz and Copelia Kahn (1980). “On the



Universal Tendency to Debasement in the Sphere of Love" (1912d, 11: 179–190) has featured in the discussion of obstacles to love regularly encountered in comedy. "Mourning and Melancholia" (1916–1917g, 14: 239–258), has been used in thinking about ambivalence toward the lost object and severe depression in tragedy or in a comedy like *Twelfth Night*. Freud's "On Narcissism" (1914c, 14: 69–91), and the thinking that grew out of it on the structure of the psyche and its roots in infantile development, have influenced many recent interpretations of Shakespeare's plays. "Negation" (1925h, 19: 235–239) has been useful to Shakespeareans as it explores one way in which the psyche negotiates its own internal contradictions.

Beyond Freud, Jacques Lacan's "mirror stage," Donald Winnicott's "transitional object," Margaret Mahler's "separation/individuation," and Erik Erikson's "basic trust" have generated new psychoanalytic readings of Shakespeare's plays. Of the classic psychoanalytic essays on Shakespeare, Ernst Kris's essay, "Prince Hal's Conflict" (Faber, 1970) has remained a model of sophistication. Integrating elements of the play's language, characterization, and plot with corresponding elements of psychic structure, Kris, examining the play's sources and speeches, recognizes Shakespeare's exceptional genius for historical and psychological observation. More recently, psychoanalysis has influenced the critics who see Shakespeare as a dramatist whose "plays and poems do not merely illustrate his identity but are in each instance a dynamic expression of the struggle to re-create and explore its origins" (Schwartz, 1980, xv–xvi). In this spirit, Janet Adelman (1992) has analyzed masculine identity and "fantasies of maternal power" and of "the maternal body" in Shakespeare.

Psychoanalytic criticism of Shakespeare has dominated the application of psychoanalytic theory to the arts and has articulated debates over the nature of applied psychoanalysis. One side insists that Shakespeare's text be treated with respect for its genre, for its formal and aesthetic properties, for its artifice, so that we must not invent an unconscious or an infantile neurosis for a character, or do wild analysis on the author; we must not go beyond the language of the text. Another position responds that a text is the product of the human psyche, which always uses the unconscious and its desires in creativity. Perhaps the most fruitful psychoanalytic interpretations of Shakespeare occupy a middle ground wherein the text is

evidence and arbiter, but where the characteristically Shakespearean illusion that a stage person has interior being, with motives that he himself does not fully understand, is recognized and explored.

MARGARET ANN FITZPATRICK HANLY

*See also:* Failure neurosis; *Hamlet and Oedipus*; Literature and psychoanalysis; Mythology and psychoanalysis; Negative capability; Parricide; Primal fantasy; "Theme of the Three Caskets, the."

### Bibliography

- Adelman, Janet. (1992). *Suffocating mothers: Fantasies of maternal origin in Shakespeare's plays. "Hamlet" to "The Tempest."* New York: Routledge.
- Faber, M.D. (Ed.). (1970). *The design within: Psychoanalytic approaches to Shakespeare.* New York: Science House.
- Freud, Sigmund. (1900a). The interpretation of dreams. Part I. *SE*, 4: 1–338; The interpretation of dreams. Part II. *SE*, 5: 339–625.
- . (1910c). Leonardo da Vinci and a memory of his childhood. *SE*, 11: 57–137.
- . (1912d). On the universal tendency to debasement in the sphere of love. *SE*, 11: 177–190.
- . (1914c). On narcissism: an introduction. *SE*, 14: 67–102.
- . (1916d). Some character-types met with in psychoanalytic work. *SE*, 14: 309–333.
- . (1925h). Negation. *SE*, 19: 233–239.
- . (1950a). Extracts from the Fliess papers. *SE*, 1: 173–280.
- Holland, Norman N. (1966). *Psychoanalysis and Shakespeare.* New York and London: McGraw-Hill Book Company.
- Kris, Ernst. (1952). *Psychoanalytic explorations in art.* New York: International Universities Press.
- Schwartz, Murray and Kahn, Copelia. (1980). *Representing Shakespeare.* Baltimore: Johns Hopkins University.

## SHAME

The word *shame* encompasses: 1) the raw emotion linked to a loss of one's bearings; 2) judgment about this state (the perception of shame as such resulting from the comparison of oneself with a model); and 3) judgment about both this emotion and the possible

causes of shame (implying possibilities for action). In all cases, shame is a sense of anxiety about being excluded, that is, not only fear of a withdrawal of love, but even withdrawal of any form of interest.

In “Three Essays on the Theory of Sexuality” (1905), Sigmund Freud linked shame to the action of the forces of repression (what was initially an object of pleasure becomes an object of modesty, disgust, or shame). By contrast, in “La honte comme angoisse sociale” (Shame as a Social Anxiety; 1929), Imre Hermann described shame as a “social anxiety” linked to attachment.

Shame always has two aspects: one relating to individual mental functioning (anxiety about mental disintegration), and the other relating to relations with the group (anxiety about being excluded). Pathological shame is to be distinguished from shame as a signal of alarm. Coping with shame involves both naming it and reinforcing the secondary processes to limit its disintegrative effects. It can be displaced or masked, especially by resignation, anger, guilt, or hate.

To a certain extent, shame was a “blind spot” for Freud and, in his wake, for many psychoanalysts who reduced it to a pathological affect linked to the ideal ego and opposed to the guilt associated with the oedipal superego. However, it is a concept that is essential to the understanding of the dynamics of social bonds (it protects people from engaging in nonhuman actions) and intergenerational secrets.

SERGE TISSERON

*See also:* Alcoholism; Bulimia; Clinging instinct; Erythrophobia; Latency period; Modesty; Nakedness, dream of; Narcissistic injury; Narcissistic rage; Obsessional neurosis; Organic repression; Self-esteem; Unpleasure.

### **Bibliography**

- Chasseguet-Smirgel, Janine. (1973). Essai sur L'Idéal du Moi. Contribution à l'état psychanalytique de la “maladie d'idéalité.” *Revue française de psychanalyse*, 37, 5–6, 735–929.
- Freud, Sigmund. (1905). Three essays on the theory of sexuality. *SE*, 7: 123–243.
- Hermann, Imre. (1982). La honte comme angoisse sociale. *Confrontation*, 8, 167–177. (Original work published 1929)
- Nathanson, Donald L. (Ed.). (1987). *The many faces of shame*. New York and London: Guilford Press.

Tisseron, Serge. (1993). *La honte, psychanalyse d'un lien social*. Paris: Dunod.

### **SHARPE, ELLA FREEMAN (1875–1947)**

British teacher and psychoanalyst, Ella Freeman Sharpe was born in Haverhill, Suffolk, England, on February 22, 1875, and died in London on June 1, 1947.

Ella Sharpe was the eldest of three daughters. Her father, who read Shakespeare to her as a child, died when she was in her teens, and she took over responsibility for the family. She studied English at Nottingham University, but turned down a position at Oxford University in order to take a teaching job to support her family. She was then co-head and English mistress of Hucknall Pupil Teachers Training Centre for boy and girls from 1904–1916.

Ella Sharpe became depressed at the death of friends and pupils during the First World War and suffered anxiety attacks. She went to the Medico-Psychological Clinic in Brunswick Square, London, was treated successfully by Jesse Murray and James Glover, and became interested in Psychoanalysis. In 1917 she gave up teaching to study psychoanalysis at the clinic.

In 1920 she went to Berlin to be analyzed by Hanns Sachs, who shared her interest in art and literature. On October 13, 1921, she was elected an Associate Member of the British Psycho-analytical Society and a Full Member two years later, in 1923.

She took an active role in the administration of the Society and Institute, and was elected to the Board and Council a number of times, being a director of the Institute when war broke out. She was first elected a member of the Training Committee in 1930, and served on it for many years. She was soon involved in teaching analytic technique, and her experience as a teacher enabled her to present her material in a lively and clear way. She was one of the first British Analysts to work with children, and she supervised both child and adult patients.

She read her first paper to the Society in 1923 on the work of Francis Thompson. At the Oxford Congress in 1929, she read a paper on sublimation and delusion, and at the Lucerne Congress in 1934, she read a paper on sublimations underlying pure art and pure science (Sharpe, 1935), using ideas from Klein's work. She was particularly interested in those artists,

including Shakespeare, who used words to express themselves. Her paper on her examination of metaphor and poetic diction shows her own rich understanding of words and the link between metaphor and instinctual tension (Sharpe, 1940).

Her lectures on technique (Sharpe, E., 1930/1931) were published in the *International Journal of Psycho-Analysis* (vols. 11 and 12) and later in book form together with her other papers (Sharpe, 1950). Her lectures on dreams were also published as a book (Sharpe, 1937).

Ella Sharpe's main impact was that she could apply Freud's technical concepts to her clinical experience and communicate it to others, and she alerted readers to the importance of understanding, more deeply, the language of patients.

PEARL H.M. KING

See also: Controversial Discussions; Great Britain; *Hamlet and Oedipus*.

### Bibliography

Sharpe, Ella F. (1930). The technique of psycho-analysis. Seven lectures. *International Journal of Psycho-Analysis*, 11, 251–277; 12, 24–60.

———. (1935). Similar and divergent unconscious determinants underlying the sublimations of pure art and pure science. *International Journal of Psycho-Analysis*, 16, 180–202.

———. (1937). *Dream analysis: A practical handbook for psychoanalysts*. London: Hogarth and the Institute for Psycho-Analysis.

———. (1940). Psycho-physical problems revealed in language: An examination of metaphor. *International Journal of Psycho-Analysis*, 21, 201–213.

———. (1950). *Collected papers on psycho-analysis*. (M. Brierley, Ed.) International Psycho-Analytical Library, vol. 29. London: Hogarth and the Institute for Psycho-Analysis.

## SIGMUND FREUD ARCHIVES

The Sigmund Freud Archives, incorporated in the United States in 1952 by the leading analysts of that period, developed under the leadership of Dr. Kurt R. Eissler, who was the chief administrative officer until 1985. Dr. Harold P. Blum succeeded him as executive

director of the archive. The other officers in 2005 were Drs. Alexander Grinstein, president; Bernard L. Pacella, secretary and treasurer; and Sidney S. Furst.

The goal of the archive is to discover, collect, and preserve all of Freud's publications, letters, and other documents and to maintain an archive of these materials. The archive also facilitates research, writing, publishing, and other activities relating to the work of Freud and other pioneers of psychoanalysis. The Sigmund Freud Collection comprises Freud's letters, publications, first editions, personal documents, photographs, movies, and other personal items. Letters and papers of Anna Freud and many other renowned psychoanalysts are in separate collections, coordinated with the Sigmund Freud Collection. The archive has a continuing contract with the Library of Congress under which the Freud Collection is protected and preserved at the Library of Congress in Washington, D.C. The Freud Collection was almost completely derestricted as of 2005, and is accessible to all scholars upon application to the Library of Congress.

As a co-trustee, the archive is also responsible for the administration and development of the Freud Museum in London. The Freud Museum opened in July 1986 and contains a major collection of Freud's personal effects, including his extensive library, antiques, study, and consulting room. The Freud Museum displays Freud's professional and working environment, and sponsors relevant education, writing, and research.

A nonprofit organization, the archive offers all scholars equal access to all unrestricted documents. For more than a decade, the archive has steadily been derestricting documents in its control. Most of the Freud correspondence that has recently become available has been released by the archive. The goal of total derestriction was reached the year 2000, when documents under Anna Freud's will were scheduled for derestriction. Then only documents legally restricted, in writing, by the donor, will still be unavailable to scholars.

Documents are released at the Library of Congress for reading and research, but such release does not entail permission for publication. Documents are released completely unaltered and unexpurgated, with the single exception of the names of psychoanalytic patients. Patients' names are deleted to protect anonymity and confidentiality, but to facilitate scholarly research,

names are available to editors of correspondence upon special application to the Sigmund Freud Archives. In such cases, the editors are bound to maintain the confidentiality of patients' identities. Everyone using the documents in the Freud Collection is obligated to abide by the rules of the Library of Congress.

Dr. Harold Blum proposed a "Freud Exhibit" to the United States Library of Congress. Developed over several years, relying mainly on the Freud Collection of the Library of Congress, it opened in 1998 at the Library of Congress in Washington, DC. It was the largest exhibit of the life and work of Sigmund Freud ever held. The exhibit traveled to venues in four continents, including several additional major American cities, Vienna, Rio de Janeiro, and Tel Aviv.

The Freud Archives continues to support Freud scholarship and research. Plans are under consideration to digitize the Freud collection and as many other Freud documents as possible. In 2004 the Sigmund Freud Archives constructed its own web site, which will eventually be linked to the Library of Congress. An outline of the Freud Collection and its contents can be viewed on the web site. Derestriction of the small number of still classified correspondence and interviews is proceeding, consistent with legal and ethical requirements.

HAROLD P. BLUM

See also: Eissler, Kurt Robert; Freud Museum.

---

## SIGMUND FREUD COPYRIGHTS LIMITED

Sigmund Freud bequeathed the income from this world copyrights, which was seen as "pocket money," to five of his grandchildren, who were still all minors at the time of his death in 1939. His will appointed three of his children, Ernst, Martin, and Anna as trustees.

After World War II, the trustees decided that a limited company should be formed to handle the copyrights, promote publication and translations, and collect royalties and distribute them to the grandchildren. The company was incorporated April 15, 1946, and acquired from the trustees the copyright in all Sigmund Freud's works and other writings, letters, and so on, by an agreement of April 5, 1947.

The company was managed for many years by Ernst Freud, operating from his home in St. John's Wood, London, where he also continued to carry on his architect's practice. With his wife, Lucie, Ernst was also closely involved with editorial work, dedicating himself wholeheartedly to keeping his father's name before the public. He acquired an intimate knowledge of his father's vast correspondence and one of the earliest volumes of these letters, a selection of various correspondents, published under the title *The Letters of Sigmund Freud 1879–1939* (1960) was entirely Ernst's idea and his almost unaided achievement. Several other volumes followed, such as *Psych-analysis and Faith; The Letters of Sigmund Freud and Oskar Pfister* (with Heinrich Meng) in 1963; *A Psycho-analytic Dialogue; The Letters of Sigmund Freud and Karl Abraham 1907–1926* (with Hilda C. Abraham) in 1965; and *The Letters of Sigmund Freud and Arnold Zweig* in 1970. It had also long been Ernst's dream to publish a picture biography of his father, using letters and other documents and photographs mainly from the family's private collection. He worked on this for many years, together with his devoted wife, Lucie. The work remained uncompleted when he died in 1970, when the German scholar and psychoanalyst, Ilse Grubrich-Simitis, took on the task of finishing it. It finally appeared as *Sigmund Freud: His Life in Pictures and Words* in 1976 and was translated into many languages.

Although in 1960 he had passed the work of administering most German and foreign language rights in his father's published works (except English, Spanish, and Portuguese) to the S. Fischer publishing house in Frankfurt, by the mid-1960s Ernst Freud's health was failing and he was seeking someone to help him. At this point the literary agent, Mark Paterson, was asked by an American publisher to clear the rights in one of Freud's pre-analytic works. He contacted Anna Freud, who referred him to her brother Ernst. The two men met and warmed to each other immediately, and Paterson was appointed as a consultant. Shortly after Ernst's death he took over as Director.

The company continued to thrive, promoting new editions of Freud's works and many more editions of correspondences. The limited company became dormant in 1987 but the name "Sigmund Freud Copyrights" continues to be used as the collective name of the literary heirs of Sigmund Freud and its affairs are handled by Mark Paterson and Associates, 10 Brook Street, Wivenhoe, Essex, GB-C07 9DS.

This company also handles the works of many other psychoanalysts, including those of Anna Freud, and in conjunction with administering the Freud copyright, maintains a small archive comprising letters and other documents, many of them originals, relating to the history of psychoanalysis.

THOMAS ROBERTS AND MARK PATERSON

*See also:* Freud, Anna; Freud, Ernst.

## SIGMUND FREUD INSTITUTE

Located in Frankfurt, Germany, the Sigmund Freud Institute is a state-supported research institute for psychoanalysis and its various applications. Research covers three broad areas: psychoanalytic therapy, foundations of psychoanalysis, and psychoanalysis and society; investigators target aspects of psychological health and illness in the context of economic development, and they study the theoretical and practical bases of psychoanalysis. The institute's psychoanalytically-oriented psychotherapy clinic focuses on treatment and research alike.

The institute is closely identified with its founder and first director, Alexander Mitscherlich (1908–1982). In the summer of 1956, Mitscherlich organized a series of conferences at the Institut für Sozialforschung (Institute for Social Research) with the support of Max Horkheimer (1895–1973). With the intention of restoring contacts with the international psychoanalytic community, Mitscherlich invited the participation of analysts who had left Germany prior to the Second World War. Somewhat later, on April 27, 1960, the Institut und Ausbildungszentrum für Psychoanalyse und Psychosomatische Medizin (Institute and Training Center for Psychoanalysis and Psychosomatic Medicine) officially opened. After moving to new quarters in West Frankfurt on October 14, 1964, it was rechristened the Sigmund Freud Institute.

Psychoanalysis originated in Frankfurt with the Frankfurter Psychoanalytisches Institut, which opened in 1929 but met an abrupt end when in 1933 the National Socialists expelled its first director, Karl Landauer, who would later die at the Nazi concentration camp at Bergen-Belsen. Heinrich Meng (1887–1972), the institute's second director, was forced to

emigrate along with colleagues Frieda Fromm-Reichmann (1889–1957), Erich Fromm (1900–1980), and Siegmund Heinrich Fuchs (S.H. Foulkes, 1898–1976).

The considerable achievement of the Sigmund Freud Institute under Mitscherlich's direction was to train new analysts with the help of analysts from abroad and to mount and maintain a conceptual and institutional forum for psychoanalysis in Germany. During the Cold War, the Sigmund Freud Institute became the most important psychoanalytic teaching institute in West Germany; its training protocols conforming to guidelines set by the German Psychoanalytic Society (DPV/API).

In addition to Mitscherlich, who led the institute from 1960 to 1976, its other directors include Clemens de Boor (1976–1983), Hermann Argelander (acting director, 1983–1985), Dieter Ohlmeier (1985–1992), and Horst-Eberhard Richter. Since 1995, in addition to providing treatment on an outpatient basis, the institute has supported research and education programs. The training of analysts, however, was transferred from the Freud Institute to the newly-created Frankfurter Psychoanalytisches Institut in 1994. Werner Bohleber became president of the Frankfurter Institut in 1994.

The Sigmund Freud Institute, state supported and independent of the university system, has greatly contributed to reestablishing psychoanalysis in Germany, with its unique dual role as a research center and training institute. It has developed an original approach to research projects and brought psychoanalytic investigations to bear on questions of social psychology.

MICHAEL LAIER

*See also:* Berliner Psychoanalytisches Institut; Foulkes (Fuchs), Siegmund Heinrich; Germany; Goethe Prize; Landauer, Karl; Meng, Heinrich; Mitscherlich, Alexander.

### **Bibliography**

Bareuther, Herbert et al. (1989). *Forschen und Heilen. Auf dem Weg zu einer psychoanalytischen Hochschule, Beiträge aus Anlass des 25 jährigen Bestehens des Sigmund-Freud Instituts*. Frankfurt: Suhrkamp.

Kutter, Peter. Germany. In *Psychoanalysis international: A guide to psychoanalysis throughout the world. Vol. 1, Europe*. (p. 114–136) Stuttgart-Bad Cannstatt: Frommann-Holzboog.

Mitscherlich, Alexander. (1980). *Ein Leben für die Psychoanalyse, Anmerkungen zu meiner Zeit*. Frankfurt: Suhrkamp.

Plänkers, Thomas et al. (1996). *Psychoanalyse in Frankfurt am Main: Zerstörte Anfänge, Wiederannäherung, Entwicklungen*. Tübingen: Diskord.

## SIGMUND FREUD MUSEUM

In 1971 in Vienna, with Anna Freud present at inaugural ceremonies, the Sigmund Freud Museum opened in Berggasse 19, the apartment house where Freud had lived and worked from 1891 until 1938. Originally the museum consisted of the rooms on the first floor (second floor in American usage) that housed Freud's office; it subsequently expanded to include Anna Freud's consulting room and the family apartment, which opened to the public in 1996. The Sigmund Freud Museum, managed by the Sigmund Freud Foundation, is private. It shares the bulk of Freud's legacy with the Freud Museum in London and the Library of Congress in Washington, D.C.

Visitors enter the museum through the entrance hall of the family's private apartment. In the lobby that leads to Freud's office, the original wood paneling with bast covering has been preserved; several of Freud's belongings are on display and his diplomas hang on the wall.

Freud's patients and visitors entered his consulting room from the waiting room, which was restored in accordance with the memories of Anna Freud and Paula Fichti, the Freud's housekeeper. Furnishings, donated by Anna Freud, comprise a wooden table, three armchairs and a dark red couch. Objects from her father's collection of antiquities are also displayed in a glass case, a selection that offers a sampling of Freud's taste and his passion for archeology. Some bookcases have been replaced by pictures from Freud's scientific career.

Patients entered Freud's offices through soundproof padded double doors; his consulting room opened onto a separate study. On the walls, photomontages by Edmund Engelman, taken in 1938, show the way the rooms were furnished just before Freud left Austria. Beginning in the consulting room and continuing through the study, documents and memorabilia line the walls. Showcases include more items from Freud's collection of antiquities; first editions of his books and offprints, some signed by him; handwritten inscriptions; and various other documents and personal

memorabilia. Photographs provide a visual and chronological account of the founder of the psychoanalysis from his birth and early childhood in Freiberg through his decades in Vienna and the final months of his life in London. Freud's education, his cultural milieu and personal relationships throughout his career are highlighted; scenes from his private life, which Freud attempted to keep strictly apart from his professional life, are also on view.

In a media room located in an adjoining room, formerly the kitchen, a documentary film, *Freud 1930–1939*, features a commentary by Anna Freud, who helped produce it just prior to her death. It includes footage of Freud from 1930 to 1939 in Vienna, Paris, and London with family, friends, and close collaborators. The original print of the film remains at the Anna Freud Center in London; the museum has exclusive rights to its use in continental Europe. Another film, by Philip R. Lehrman and Lynne Lehrman Weiner, *Sigmund Freud. His Family and Colleagues, 1928–1947*, finished in 1985, is also shown at the museum.

Anna Freud's consulting room, dedicated in her memory, opened in November 1992 on the occasion of the tenth anniversary of her death; furniture from the Freud family private apartments and part of Anna Freud's library are on view. A multipurpose room (three former bedrooms) has been appointed for exhibitions and lectures. A library, which opened in the museum in 1991, has holdings of over 30,000 items, the largest collection of its kind in Europe.

In 1996, the Sigmund Freud Museum celebrated its twenty-fifth year; on this occasion, the new exhibition room and lecture hall were inaugurated. Together with the exhibition and lecture rooms they provide suitable spaces for temporary exhibitions. In 2002, a show called "Freud's Lost Neighbors" was put on; it showed the history of the residents of the house at Berggasse 19 from 1939 to the present. The Foundation for the Arts, Sigmund Freud Museum Vienna, a collection of contemporary art, has been on display in the exhibition rooms since 1997; the theme is the relationship between psychoanalysis and artistic production. In 2003, the Museum opened another exhibition space on the ground floor, with a display window facing the street. This is used for the mounting of art installations.

INGRID SCHOLZ-STRESSER

*See also:* Austria; Berggasse 19, Wien IX.

## SIGNAL ANXIETY

In the *Three Essays on the Theory of Sexuality*, written in 1905, Sigmund Freud saw the anxiety of separation as a special case of anxiety based on the phenomenon of “unused libido.” The absence of the mother (due to separation) prevented the infant from binding its affects to the maternal representation and it was these affects, together with their libidinal energy, that were transformed into anxiety. Otto Rank (1924) saw anxiety as rooted in the trauma of birth, which constitutes the quintessential separation experience (biologically, in fantasy, etc.).

In *Inhibitions, Symptoms and Anxiety* (Freud, 1926d [1925]), which, to a large extent, is a response to the position taken by Otto Rank two years earlier, Freud developed the theory of signal anxiety, which represents a kind of evolutionary progress since it involves anticipatory behavior. The infant no longer experiences anxiety when faced with the loss of an object but when faced with the fear of the loss of love from the object. There Freud developed different models of anxiety that, rather than being mutually exclusive, probably refer to different types of anxiety and different maturational steps. The conceptual transition from automatic anxiety to signal anxiety involves a profound reworking of his thinking about repression. In the case of automatic anxiety Freud made anxiety a direct consequence of repression. Repression, by ejecting the instinctual representation from consciousness, leaves a certain amount of libido unused, which is immediately transformed into anxiety. “One of the most important results of psycho-analytic research is this discovery that neurotic anxiety arises out of libido, that it is the product of a transformation of it, and that it is thus related to it in the same kind of way that vinegar is to wine” (1905d, note of 1920). When discussing signal anxiety, repression is no longer the origin but the consequence of the anxiety.

When an instinctual representation becomes dangerous, threatening, or guilt-ridden, it gives rise to anxiety within the ego, leading to repression. Anxiety now serves to alert the subject to the dangers associated with the possible separation and is no longer simply the expression of an instantaneous and automatic anxiety reaction to loss or separation.

BERNARD GOLSE

See also: Anxiety.

## Bibliography

- Freud, Sigmund. (1905d). Three essays on the theory of sexuality. *SE*, 7: 130–243.
- . (1926d). Inhibitions, symptoms, and anxiety. *SE*, 20: 87–172.
- Rank, Otto. (1924). *The trauma of birth*. Reprinted, with a new introduction by E. James Lieberman. New York: Dover Press, 1993.

## SIGNIFIER

As it is understood today, the notion of the signifier is attributed to Ferdinand de Saussure, founder of linguistics and semiology and author of the influential *Course of General Linguistics* (1907/1960). For Saussure, the linguistic sign was a mental entity with two aspects: the signified (the “concept”) and the signifier (the mental impression of the sound). The relationship between these two aspects, which Saussure compared to the recto and verso of a sheet of paper, was considered “arbitrary” in that what linked signifier to signified was merely a convention: the signifier “sister” and the signifier “soeur,” for instance, both refer to the same signified element, even though they belong to two different linguistic systems. At the same time, signifier and signified were connected syntagmatically and paradigmatically, and these connections—and not the designation of a referent or external object—were the basis of the meaning of statements. In the wake of Saussure, structural linguistics from Roman Jakobson to Émile Benveniste built extensively on his work. This account of the structure of the sign supplied the chief algorithm of the science of semiology, whose mandate was to assess and decipher all the sign systems generated by a given society, linguistics being merely a part of this whole—and a model for it.

Critical thinking about the signifier centered at first on what was called the priority of the signifier relative to the signified. Inasmuch as the material nature of signifiers was highly diverse (including sounds, images, objects, text, and so on), semiology opened onto all fields of expression—art, fashion, discourse—to the point where it came to be defined as the science of the signifier, or rather, of signifying practices (Kristeva). Claude Lévi-Strauss’s structural anthropology is a magisterial demonstration of this linguistics-inspired approach.

In psychoanalysis, Jacques Lacan, invoking both Freud and Saussure, as well as linguistic and anthropological structuralism, took the discussion beyond the signifier to what he called “the signifying chain.” Deeming that “the unconscious is structured like a language,” Lacan borrowed the methodology and operating concepts of Saussurian linguistics and applied them in an idiosyncratic way to psychoanalysis. In his view the discovery of the unconscious coincided with the discovery of a subject whose position, decentered (or “ex-centric”) relative to consciousness, was established solely by virtue of the retroactive operation of certain signifiers. Accordingly, the definition of the signifier as a component in a signifying chain was worked out on the basis of three notions:

- *Vacillation*: The signifier can fulfill its purpose of engendering meaning only by ceding its place to another signifier with which it is linked in the chain of signifiers.
- *The subject*: Located nowhere before the advent of the signifier, nor anywhere outside the signifier, the subject receives its place from the signifier, yet can occupy its own place only as a function of the *lack* whose place a signifier fills; the subject thus becomes the *extra* signifier that supports enunciation as it proceeds. This is the basis of Lacan’s formula according to which the order of the signifier is founded on the fact that “a signifier is what represents a subject to another signifier” (*Écrits*).
- *The object*: The object is that towards which discourse qua desire is directed; it governs the signifying chain and its operation. The object of enunciation too is always decentered relative to the one designated by an utterance. That object is also always lacking, for the subject is never finished with the work of signifying that desire entails. For Lacan, that work is orthonormal, both vertically by virtue of metaphor (condensation or substitution of signifiers), and horizontally by virtue of metonymy (displacement or contiguity of signifiers).

The idea of the signifier is cardinal in Lacan’s theory, determining as it does the very definition of the unconscious, of the subject, of the oedipal law, of castration, and of desire. It lies at the intersection of a reformulation of the Oedipus complex conceived of as the subjugation of the subject to the law (of language)

and a consideration specific to Lacan (and only hinted at by Freud) of the effects of speech on the subject as revealed by analysis. To say that the unconscious is a “signifying chain” is the same thing as saying that the “symbolic function” is what superimposes the rule of culture (Oedipus) on the rule of nature. The Other was viewed by Lacan from the outset as the logical empty place where the laws of language and speech are laid down; he described the Other as a “treasure trove of signifiers.” The fact remains that Lacan’s system retained aspects not subsumed by the linguistic realm: the “subject” (of the unconscious) qua “signifier effect,” the object of desire as alien to the sphere of need and even to that of demand, desire as inseparable from speech effects. This independent realm of the signifier was anchored to that “pure signifier,” the Name-of-the-Father: the three clinical categories of neurosis, psychosis, and perversion were viewed as three possible variants of the relationship of the subject of the unconscious to this paternal signifier. Later in his work, Lacan would in fact insist that his teaching was not akin to linguistics; before his final “knot” theory, he proposed an account of “the letter” as an element linking the three orders of the Real, the Imaginary, and the Symbolic—as distinct from his first theory of the signifier, which seemed to concern itself solely with the order of the Symbolic.

Saussure’s account of the structure of the sign (signifier/signified) and Lacan’s thinking on the signifier prompted a philosophical critique of the notion of the signifier that took Freud’s idea of “facilitation” as its starting-point and developed the concept of “trace” (Derrida). The resulting deconstruction of the Saussurian sign led in turn to the deconstruction of metaphysics and opened up the question of the truth of meaning from the point of view of Derrida’s “grammatology”—a perspective of distinct relevance to psychoanalytical interpretation. In the light of psychoanalytical discourse, though also in that of poetic language, Julia Kristeva has suggested another way of understanding the Saussurian signifier: first, in “semiotic” terms, taking into account the infralinguistic indications of the drive, as discernible in the language of poetry and also in the discourse of psychotic or depressed patients—indications excluded from the realm of the signifier as understood by Lacan; and, secondly, in “symbolic” terms, opening up the dimension of signs and syntax.

JULIA KRISTEVA



See also: Economic point of view; Intergenerational; Linguistics and psychoanalysis; Sense/nonsense; Signifier/signified; Symbol; Symbolism; Thing-presentation; Word-presentation.

### Bibliography

- Derrida, Jacques. (1974). *Of grammatology* (Gayatri Chakravorty Spivak, Trans.). Baltimore: Johns Hopkins. (Original work published 1967)
- Kristeva, Julia. (1974). *La Révolution du langage poétique. L'Avant-garde à la fin du dix-neuvième siècle—Lautréamont et Mallarmé*. Paris: Seuil.
- Lacan, Jacques. (2002). *Écrits: A selection* (Bruce Fink, Trans.). New York: Norton. (Original work published 1966)
- Saussure, Ferdinand de. (1960). *Course in general linguistics* (Wade Baskin, Trans.). London: Peter Owen. (Original work published 1907)

## SIGNIFIER/SIGNIFIED

A signifier, an element of language, is a material representation of a linguistic sign. In psychoanalysis, it is a phonemic sequence of the discourse that intervenes in conscious and unconscious processes to determine the subject engaged in the discourse. A signified is the idea or concept associated with a signifier, which together constitute the linguistic sign.

These elements, which come from Ferdinand de Saussure's linguistic theory, were introduced and problematized in the field of psychoanalysis by Jacques Lacan during his "return to Freud" phase in early 1950s. Lacan relied on the following main points of Saussure's structural model. The linguistic sign, which belongs to language, establishes a relationship between an acoustic wave form, or signifier, and a concept, or signified (Figure 1).

The directed and temporal sequence of an articulation presupposes the division of language into two axes: the *syntagmatic axis*, which refers to a system of speech as a system of signs capable of being combined and concatenated, and the *paradigmatic axis*, which refers to a system of language as a system of signs selected and substituted for particular meanings.

A sign taken in isolation does not define a meaning: a signifier can refer to several signifieds. Each sign thus gains its value by being placed in the context of other

FIGURE 1

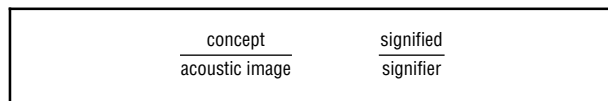

signs. The "break" between a flow of sounds and a flow of thought associates the signifier with a signified.

Freud's definition of psychoanalysis as a treatment through speech led Lacan to propose that the "unconscious [is] structured like a language." This theory, advanced and developed on the basis of Freud's work, led Lacan to assign to the signifier and to the structure of language a fundamental role in the unconscious processes of the speaking subject.

At the level of the primary processes, Lacan posited an analogy between condensation and metaphor, as a substitution of meaning, and between displacement and metonymy, as a connection in meaning. At the level of the expressions of the unconscious, the elaboration of symptoms appears to be analogous to the mechanisms of metaphor, while witticisms and slips of the tongue appear to be analogous to metaphorical condensation and/or metonymic displacement.

The dynamic of desire in the speaking subject is expressed in an indefinite sequence of signifiers operating metonymically. However, this notion only holds because Lacan transformed Saussure's definition of the linguistic sign and, more specifically, that of the signifier in the structure of language. He referred to this as his "linguisteria" (*linguistérie*).

Analysis of the neuroses, the structure of unconscious formations, and the discourse of psychotics led Lacan to believe that the signifier is autonomous and dominant over the signified, which he symbolized as shown in Figure 2.

The bar that separates S from s shows the relationship between the subject and the language. The subject is thus subordinated to signifiers, without always having access to the meaning that they delimit. This is seen clearly in psychotic discourse, which unleashes the signifier.

The primacy of the signifier implies that signifieds draw their coherence only from a network of signifiers. The relationship between signifier and signified can come undone at any time. Lacan replaced Saussure's "break" (*coupure*), Saussure's correspondence between the flow of signifiers and the flow of signifieds, with

FIGURE 2



the *point de capiton* (literally, “quilting stitch”), the operation that stops the indefinite slippage of meaning by making a deferred limitation.

The logic of the signifier thus defined by Lacan calls for a change in how the unconscious processes are analyzed. Lacan focused on how the unconscious expresses itself in the patient’s language, as revealed through meter, punctuation, and interpretative breaks. Within this logic, certain signifiers, such as “phallus”, “Name-of-the-Father”, and “lack in the Other”, are invested with a fundamental metapsychological value.

JOËL DOR

*See also:* Blank/nondelusional psychoses; Cinema and psychoanalysis; Displacement; Ego ideal/ideal ego; Fantasy, formula of; Feminine sexuality; Feminism and psychoanalysis; Foreclosure; Formations of the unconscious; Four discourses; Graph of Desire; Imaginary identification/symbolic identification; Infans; Jouissance (Lacan); Letter, the; Literature and psychoanalysis; Matheme; Metaphor; Metonymy; Monism; Mother goddess; Name-of-the-Father; Negation; Object *a*; Other, the; Parade of the signifier; Phallus; Philosophy and psychoanalysis; Phobias in children; Phobic neurosis; Psychoses, chronic and delusional; Real, the (Lacan); Schizophrenia; Sexuation, formulas of; Signifier; Signifying chain; Slips of the tongue; Splitting of the subject; Structuralism and psychoanalysis; Subject; Subject of the unconscious; Subject’s castration; Symbolic, the (Lacan); Symptom/sinthome; Thing, the; Topology; Unary trait.

### Bibliography

- Dor, Joël. (1997). *Introduction to the reading of Lacan: The unconscious structured like a language*. Northvale, N.J.: J. Aronson.
- Lacan, Jacques. (2002). The function and field of speech and language in psychoanalysis. In his *Écrits: A selection* (Bruce Fink, Trans.). New York: W. W. Norton. (Original work published 1953.)
- . (1993). *The seminar of Jacques Lacan* (Book 3: *The psychoses*). (Russell Grigg, Trans.). New York: W. W. Norton. (Original work published 1955–1956)
- Saussure, Ferdinand de. (1986). *Course in general linguistics* (Roy Harris, Trans.). LaSalle, IL: Open Court. (Original work published 1915)

## SIGNIFYING CHAIN

Inspired by the notion of facilitation, which was central to Freud’s description of the functioning of the psychic apparatus, Jacques Lacan defined the signifying chain as an association and combination of signifiers, connected in diverse ways, like the “links by which a necklace firmly hooks onto a link of another necklace made of links” (Lacan, 2002a, p. 145). The unconscious activity of desire is expressed through the associative and combinatory links of the signifier and is repeated in a kind of succession that sets up a chain reaction.

The signifying chain originates in the process of primal repression, during which the Name-of-the-Father signifiers are substituted for the signifier of the desire for the mother. From then on, conscious and unconscious signifiers are woven together through metonymy and metaphor, the two functions that generate signifieds.

The signifying chain has only one destiny: to insert the subject’s unconscious desire in the subject’s utterances. Thus it constitutes the design and the weave of the speaking subject’s psychic fabric. More generally, it is involved in all psychic causality.

JOËL DOR

*See also:* Four discourses; Graph of Desire; Infantile, the; Letter, the; Matheme; Psychic causality; Signifier; Symptom, sinthome; Unary trait.

### Bibliography

- Lacan Jacques. (1993). *The seminar of Jacques Lacan*. Book 3: *The psychoses, 1955–1956* (Russell Grigg, Trans.) New York: W. W. Norton.
- . (2002a). *Écrits: A selection* (Bruce Fink, Trans.) New York: W. W. Norton.
- . (2002b). The function and field of speech and language in psychoanalysis. In his *Écrits: A selection* (Bruce Fink, Trans.) New York: W. W. Norton. (Original work published 1953)
- . (2002c). The instance of the letter in the unconscious, or reason since Freud. In his *Écrits: A selection* (Bruce Fink, Trans.) New York: W. W. Norton. (Original work published 1957)
- . (2002d). The subversion of the subject and the dialectic of desire in the Freudian unconscious. In his *Écrits: A selection* (Bruce Fink, Trans.) New York: W. W. Norton. (Original work published 1960)

## SILBERER, HERBERT (1882–1923)

Austrian psychoanalyst Herbert Silberer was born on February 28, 1882, in Vienna, where he ended his life by suicide on January 12, 1923.

Victor Silberer, his father, was a self-made man who ran a sports newspaper and a publishing house. A sportsman himself, Herbert was one of the pioneers of Austro-Hungarian aeronautics. He came to psychoanalysis self-taught, with a view to resolving his personal conflicts.

After receiving Silberer's observations on the intermediary stages between waking and sleep, Freud advised Jung (July 19, 1909) to publish the paper, remarking, "Silberer is an unknown young man, probably a better-class degenerate; his father is a well-known figure in Vienna, a member of the city council and an 'operator.' But his piece is good and throws light on an aspect of dream work" (p. 242).

In 1909, Silberer's "Report on a Method of Eliciting and Observing Certain Symbolic Hallucination-Phenomena" was published in the second volume of the newly launched *Jahrbuch*; it eventually appeared in English (Silberer 1951). In this article, Silberer described the hypnagogic states and explained the formation of symbols as revealing affects and emotions in a "functional" way and personalizing various states characteristic of the dreamer's psychic processes. In "On Narcissism: An Introduction" (1914c), Freud wrote that this was "one of the few indisputably valuable additions to the theory of dreams," adding that Silberer had "thus demonstrated the part played by observation—in the sense of the paranoiac's delusions of being watched—in the formation of dreams" (p. 97).

In October 1910, Silberer became a member of the Vienna Psychoanalytic Society. Articles published over the next several years showed Silberer's increasing interest in esotericism and mysticism. Freud recognized his contributions to symbolism, as did Wilhelm Stekel, with whom Silberer would maintain a close relationship after the latter's rupture with Freud.

Silberer's major work, *Problems of Mysticism and Its Symbolism*, published in 1914 and translated into English three years later, distinguished Freud's views on the dream from his own. Freud criticized his concept of "anagogic" interpretation, describing the evolution of dreams during treatment toward more general and universal symbolization, and he also noted Silberer's

deemphasis of sexuality and tendency to rationalize. Similarly, Ernest Jones wrote to Freud (February 8, 1911), "As to Silberer, I don't know what to make of him. He seems to be badly infected by the philosophic virus." Jones subsequently elaborated still stronger criticism of Silberer in his 1916 paper on "The Theory of Symbolism." Although it left Freudian colleagues more than skeptical, Silberer's comparison of transference to the alchemical reactions between male and female elements in nature inspired both Theodor Flournoy and, in particular, Carl G. Jung.

With Wilhelm Stekel and Samuel Tannenbaum, Silberer directed a review published in the United States, *Psyche and Eros*. Despite resigning after the publication grew increasingly hostile to Freud and psychoanalysis, his association with the journal further damaged his relations with the Vienna Society. Paul Roazen (1976) published a letter of Freud dated April 17, 1922: "Most Honored Sir, I ask you not to make your intended visit to me. After my observations and impressions of recent years I no longer desire personal contact with you." Roazen believes this letter was addressed to Silberer and became one of the motives for his suicide nine months later. Bernd Nitzschke (1989) does not share Roazen's conviction; based on the obituary by Stekel (1924), he believes the letter was addressed to Silberer's father, Viktor. In fact, Stekel, who was surprised by Silberer's suicide, stressed the Vienna Society's unfavorable reaction to his lecture on dreams on November 1, 1922.

Forty years after his death, Carl G. Jung wrote: "Herbert Silberer has the merit of being the first to discover the secret threads that lead from alchemy to the psychology of the unconscious" (Jung, 1955–57, p. 792).

ALAIN DE MIJOLLA

*See also:* Alchemy; Anagogical interpretation; Functional phenomenon; Representability.

### Bibliography

- Freud, Sigmund. (1914c). On narcissism: an introduction. *SE*, 14: 67–102.
- . (1993 [1908–39]). *The complete correspondence of Sigmund Freud and Ernest Jones, 1908–1939*. Cambridge, MA: Belknap Press of Harvard University Press.
- Jones, Ernest. (1961 [1916]). *The theory of symbolism*. In *Papers on psychoanalysis*. Boston: Beacon Press.

Jung, Carl Gustav. (1955–57). *Mysterium Conjunctionis*. An Inquiry into the separation and synthesis of psychic opposites in alchemy. *Coll. Works*, Vol. 14, London, Routledge & Kegan Paul.

Nitzschke, Bernd. (1989). Freud et Herbert Silberer. Hypothèses concernant les destinataires d'une lettre de Freud de 1922. *Revue internationale d'histoire de la psychanalyse*, 2, 267–277.

———. (1989). Freud und Fechner. Einige Anmerkungen zu den psychoanalytischen Konzepten "Lustprinzip" und "Todestrieb." In *Freud und die akademische Psychologie. Beiträge zu einer historischen Kontroverse*. Munich: Psychologie Verlagsunion.

Roazen, Paul. (1976). *Freud and his followers*. New York: Alfred A. Knopf.

Silberer, Herbert. (1917). *Problems of mysticism and its symbolism*. New York: Moffat, Yard.

———. (1951). Report on a method of eliciting and observing certain symbolic hallucination-phenomena. In Rapaport, David. *Organization and pathology of thought. Selected sources*. New York: Columbia University Press.

Stekel, Wilhelm. (1924). In memoriam Herbert Silberer. *Fortschritte der Sexualwissenschaft und Psychoanalyse*, 1, 408–420.

## SILBERSTEIN, EDUARD (1856–1925)

Eduard Silberstein, an intimate friend of Freud's when he was an adolescent and young adult, was born on December 27, 1856, in Iasi, then the capital of Romania, and died in Braïla, Romania, in 1925. Freud's eighty extant letters to Silberstein, part of their steady correspondence from 1871 to 1881, have been preserved and published.

His father, Osias Silberstein, was a prosperous merchant, Orthodox Jew, and father of four. He sent Eduard and his brother Adolf to a local heder, but they soon rebelled against the narrowly religious education. Eduard then pursued his studies in Vienna, where he was one of Freud's classmates in the gymnasium. They were friends by 1870.

Tongue in cheek, Freud and Silberstein founded a secret "Spanish Academy" (*Academia castellana*), of which they were the sole members. In correspondence Freud often signed using the nickname "Cipión, dog of the hospital at Seville"; Silberstein was "Berganza," another canine hero from Cervantes's *Exemplary Stories*.

Freud's letters paint a lively picture of Freud's adolescence: the two students' academic worries, readings,

and early infatuations with girls. During the summer of 1871, when Freud was fifteen, Silberstein and Freud went to Freiberg, where Freud had a very brief meeting with Gisela Fluss, a girl almost twelve years old. This encounter was important enough to Freud that he recalled it while writing "Screen Memories" (1899a) and again in a slip of the pen in preparing his "Notes on a Case of Obsessional Neurosis" (1909d, p. 209).

During his first stay in Great Britain in 1875, at the Manchester home of his half-brothers Emanuel and Philipp, and during his stay in Trieste, Italy, at the experimental zoological station, Freud confided to Silberstein his impressions, youthful desires, and ambitions. Freud's last preserved letter to Silberstein dates to January 1881, when Freud was preparing to receive his medical diploma.

On February 7, 1884, Freud wrote to his fiancée, "We became friends at a time when one doesn't look upon friendship as a sport or an asset, but when one needs a friend with whom to share things. We used to be together literally every hour of the day that was not spent on the school bench. . . . [We] compiled a great mass of humorous work which must still exist somewhere among my old papers" (1960a [1873–1939], pp. 96–97). Those papers probably disappeared in the fire of April 1885.

As for Silberstein, after his exams he left for Leipzig to study jurisprudence, later moving to Vienna, where in 1875 he attended classes in law and Franz Brentano's lectures on philosophy. He took his doctorate in law in 1879, but would never practice. After a reversal in his family's financial situation, he was compelled to work in banking, then in the grain trade.

Silberstein's first marriage, with Pauline Theiler, ended sadly. According to his granddaughter Rosita Braunstein Vieyra, this young woman "became mentally ill, was treated unsuccessfully by his friend Sigismund Freud, and threw herself from a window in Freud's apartment building" (Freud, 1989a [1871–1881, 1910], p. 192). By other accounts, published at the time of the incident in 1891, she did not actually see Freud before committing suicide. Silberstein subsequently remarried and had a daughter, Theodora.

A socialist, Silberstein, together with fellow student Heinrich Braun, initiated Freud into social-democratic politics. Throughout his life Silberstein was politically active and played an important role in the Jewish community, fighting for the right of Jews to become

Romanian citizens and for their right to vote. He was president of the Hebrew Immigrant Aid Society, the Alliance Israélite universelle, and B'nai Brith.

Three years after Silberstein's death, Freud recalled him a final time in a letter to the president of B'nai Brith in Braila: "I was deeply touched to learn of the honor your Lodge has bestowed on my late childhood friend, Dr. Eduard Silberstein. I spent many years of my boyhood and young manhood in intimate friendship, indeed in fraternal fellowship, with him. . . . Later, life and physical distance separated us, but early friendship can never be forgotten" (1989a [1871–1881, 1910], p. 186).

ALAIN DE MIJOLLA

See also: Fechner, Gustav Theodor; Fluss, Gisela; Freud, Sigmund (siblings); Vienna, Freud's secondary school in; Vienna, University of.

### Bibliography

- Freud, Sigmund. (1899a). Screen memories. *SE*, 3: 299–322.
- . (1909d). Notes on a case of obsessional neurosis ("the rat man"). *SE*, 10: 151–318.
- . (1960a [1873–1939]). *Letters of Sigmund Freud* (Tania Stern and James Stern, Trans.) New York: Basic Books.
- . (1989a [1871–1881, 1910]). *Letters of Sigmund Freud to Eduard Silberstein, 1871–1881* (Arnold J. Pomerans, Trans.) Cambridge, MA: Harvard University Press, 1990.

## SILENCE

Silence in the course of an analytical session, whether it comes from the patient or the analyst, has constantly posed problems for the theorists of psychoanalytical technique.

According to certain authors, silence is to be interpreted as a resistance (Karl Abraham, Sándor Ferenczi, Sigmund Freud, Wilhelm Reich, Otto Fenichel, Anna Freud, Stephen Weissman). Edward Glover was the first to emphasize the counter-transference positions involved in it, and noted the role of the super-ego. Karl Abraham, Sándor Ferenczi, Edmund Bergler, Ella Sharpe, Robert Fliess and Kata Levy make of it a particular mode of instinctual expression, while Rudolph Loewenstein and Leo S. Loomie approach it as the

translation of a distortion of the ego. Silence has also been studied as an object relation by Jacob Arlow (defense or discharge) and by Ralph Greenson (resistance or communication), as an object relation properly speaking (Carel Van der Heide, Meyer A. Zelig) and as a particular mode of object choice (Robert Barande).

According to Freud ("The Dynamics of Transference," 1912b, p. 101): "If a patient's free associations fail, the stoppage can invariably be removed by an assurance that he is being dominated at the moment by an association which is concerned with the doctor himself or with something concerned with him. As soon as this explanation is given, the stoppage is removed, or the situation is changed from one in which the associations fail into one in which they are being kept back." And elsewhere, in "The Theme of the Three Caskets" (1913f, p. 295): "in dreams dumbness is a common representation of death." He also says in "Remembering, Repeating and Working-Through" (1914g, p. 150) that when the patient "is silent and declares that nothing occurs to him," this, "of course, is merely a repetition of a homosexual attitude which comes to the fore as a resistance against remembering anything," while Sophie Morgestern, in "A Case of Psychogenous Muteness" (1927), gave us the first work known in France to use drawing, in place of speaking, as a method of child analysis.

Other authors have added to these views: silence is "a state of restoration of primary narcissism, it is the realization of desire" enabling one to "re-experience narcissistic omnipotence" (Pierre Luquet, Béla Grunberger), or a sign of "good maternal care that provides the ego with a silent but vital support" (Donald W. Winnicott). The sense of the ego's inability to mask instincts from the super-ego in discourse may explain the very frequent silences that are encountered in child therapy. In the analytical couple, of whatever kind, "the support of the amorous exchange as the patient lives it is indeed silence [. . .] It's within the crucible of the therapist's silence that the patient's spoken words will be revealed as fantasy" (Robert Barande).

Luisa de Urtubey, in her report on the "work of the counter-transference" (1994), sets out the theories of a great number of authors who discuss silence. For her, "silence—as well as speech, its interpretations, its emphases, the links it weaves—is the expression of counter-transference in this analytical space and at this precise moment." Pearl Lombard expresses an aptitude for the silent maternal counter-transference: "speech is

silver, silence is golden” (“The Silence of the Mother, or: Twenty Years Later”, 1986). She remarks that “a succession of images wells up in the analyst’s mind as she or he accompanies a silent patient: astonishment, anxious questioning, an experience of depression and an obligation to imagine if we are to survive, but also if our patients are to survive psychologically. There are long periods in which the exchange between patient and analyst, although it is very intense, happens in both directions, in the mysterious depth of silence. The way these analyses evolve depends to a large extent on the existence of counter-transferential movements that are sufficiently intense to arouse representations of highly personal images or things, related to the analyst’s narcissism—representations that can invigorate the treatment only insofar as they can be linked and bound to a moment in the patient’s history, either in narrative form, or in the shape of images visualized on the basis of that narrative. Thus the vital bridge between word representations and thing representations is created or recreated in the analyst himself or herself. This bridge is highlighted by interpretation, the invigorating effect of which fulfils the silence and makes it speak.”

The evaluation of “silence” is possible only if each case—patient and analyst—is taken on its merits.

PEARL LOMBARD

See also: “Fragment of an Analysis of a Case of Hysteria” (Dora/Ida Bauer); Listening; Nacht, Sacha Emanoel; Stone, Leo.

### **Bibliography**

- Barande, Robert. (1989). *Parcours d'un psychanalyste, son esthétique et son éthique*. Paris: Pro-Edi.
- Freud, Sigmund. (1912b). The dynamics of transference. *SE*, 12: 97–108.
- . (1913f). The theme of the three caskets. *SE*, 12: 289–301.
- . (1914g). Remembering, repeating and working-through (Further recommendations on the technique of psycho-analysis II). *SE*, 12: 145–156.
- Green, André. (1979). Le silence du psychanalyste. *Topique*, 23, p. 5–25.
- Lombard, Pearl. (1986). Le silence de la mère ou vingt ans après. *Bulletin de la Société de psychanalyse de Paris*, 9, p. 33–48.

Nasio, Jean-David. (1987). *Le Silence en psychanalyse*. Paris: Rivages.

Urtubey, Luisa de. (1994). Le travail de contre-transfert. *Bulletin de la Société de psychanalyse de Paris*, 31, p. 147–148.

---

## **SIMMEL, ERNST (1882–1947)**

Neurologist and psychoanalyst Ernst Simmel was born on April 4, 1882, in Breslau, Germany (now Wrocław, Poland) and died in Los Angeles on November 11, 1947.

From a Jewish background, Simmel was the youngest of nine children. His father, Siegfried, was a banker; his mother, Johanna, managed an employment agency for domestic servants.

After studying medicine and psychiatry in Berlin and Rostock, Simmel received his medical degree in 1908; his dissertation concerned the psychogenic etiology of dementia praecox. Early in his career he worked as a general practitioner in Berlin. During World War I, however, he served as military doctor and chief of a hospital for psychiatric battle casualties in Posen. There he introduced the use of psychodynamic principles; at the time, he was still self-taught in psychoanalysis.

Returning to Berlin after the war, Simmel underwent a didactic analysis with Karl Abraham in 1919. Together with Abraham and Max Eitington, he helped establish the Berlin Psychoanalytic Institute in 1920. He served as president of the Berlin Psychoanalytic Society from 1926 to 1930, and founded and served as chief physician of the Tegel sanatorium at Schloss Tegel, outside Berlin, in 1927. The sanatorium, the first ever designed to employ psychoanalytic principles in treating patients who might benefit from observation, went bankrupt and closed in 1931.

In 1910, Simmel married Alice Seckelson, and the couple would have two sons. In 1929 he married his second wife, Hertha Brüggemann.

Simmel, a liberal who had helped to found the Society of Socialist Physicians and served as its president from 1924 to 1933, ran afoul of Nazi authorities soon after Hitler came to power in 1933. Emigrating to the United States in 1934, he moved to Los Angeles after a brief period at the Topeka Psychoanalytic Institute. He was instrumental in founding the Los Angeles Psychoanalytic Institute soon after the Second World

War; he also helped establish the San Francisco Psychoanalytic Society, and served as its first president.

Simmel published both clinical and theoretical papers. *On the Psychoanalysis of War Neuroses* (1921) became a classic. His 1927 lecture at the Innsbruck Congress on the use of psychoanalytic principles in treating institutionalized patients was also highly original. A major theoretical contribution is "Self-Preservation and the Death Instinct," published in 1944. Another significant contribution to theory was Simmel's hypothesis concerning the existence of pre-oedipal anal libido, germane to certain psychosomatic and psychotic disorders. These ideas would find resonance in the work of Melanie Klein, Wilfred Bion, and Donald Meltzer.

Simmel also published some thirty original works on social issues, clinical problems, and matters of mental health policy. He is important both as a founder of the institutions noted above and for establishing a place for psychoanalysis in health care and suggesting its applications to clinical medicine. Many of his works concern psychosomatic medicine, including his "Über die Psychogenese von Organstörungen und ihre psychoanalytische Behandlung" (The Psychogenesis of Organic Disturbances and Their Psychoanalytic treatment") from 1931. He edited the anthology *Anti-Semitism. A Social Disease*, published in 1946. *Psychoanalyse und ihre Anwendungen* [Psychoanalysis and its applications], a collection of numerous abstracts, lectures, and unpublished manuscripts, appeared in 1993.

LUDGER M. HERMANN  
ULLRICH SCHULTZ-VENRATH

*See also:* Alcoholism; Berliner Psychoanalytische Poliklinik; Berliner Psychoanalytisches Institut; *Christians and Jews: A Psychoanalytical Study*; First World War: The effect on the development of psychoanalysis; Germany; Indications and contraindications for psychoanalysis for an adult; "Lines of Advance in Psycho-Analytic Therapy"; Money and psychoanalytic treatment; Racism, antisemitism, and psychoanalysis; Relaxation principle and neo-catharsis; Technique with adults, psychoanalytic; Tegel (Schloss Tegel); War neurosis.

### Bibliography

Peck, John S. (1966). Ernst Simmel: psychoanalytic pioneering in California. In F. Alexander, S. Eisenstein, M. Grotjahn (Eds.), *Psychoanalytic pioneers*. New York: Basic Books.

Simmel, Ernst. (1921). *On the psychoanalysis and the war neuroses*. London: International Psychoanalytic Press.

———. (1931). Über die Psychogenese von Organstörungen und ihre psychoanalytische Behandlung. In *Report on the sixth general medical congress for psychotherapy* (p. 56–65; 251–260). Leipzig: Hirzel.

———. (1937). The psychoanalytic sanitarium and the psychoanalytic movement. *Bulletin of the Menninger Clinic*, 1, 133–143.

———. (1944). Self-preservation and the death instinct. *Psychoanalytic Quarterly*, 13, 160–185.

———. (1946). *Anti-Semitism: A social disease*. New York: International Universities Press.

———. (1993). *Psychoanalyse und ihre Anwendungen*. Frankfurt-am-Main: S. Fischer.

## SKIN

The skin is of interest to psychoanalysis because it is anaclitically related to narcissism, because it is an erotogenic zone, and because it is the object of particular kinds of assaults. Manifestly, the skin is a potential vector for the main instincts (attachment, libido, destructive impulses).

At the end of the first essay of *Three Essays on the Theory of Sexuality* (1905d), in connection with his notion of polymorphous component instincts, Freud treated the skin as an erotogenic zone specifically excitable by the sadism/masochism "pair of opposites," in contrast with the eyes, which he conceived of as the bodily seat of the voyeurism/exhibitionism antithesis. Later, in his paper "A Child Is Being Beaten" (1919e), he described and analyzed the basic scene in masochism: an active adult beats a passive child, while another child bears silent witness to the event.

The skin has a particular place in the evolution of living beings: while the husk characterizes the vegetable realm and the membrane the animal realm, the skin is peculiar to vertebrates. In the development of the embryo in vertebrates, the ectoderm gives rise to both the skin and the cortex, so that the skin is in a sense the surface of the brain. The structure of the skin is complex in that it is a sense organ that contains the other sense organs. It comprises several interlocked layers of greatly varied structures. The skin and the sense organs that it envelops constitute an interface ensuring the individual's contact with the outside world. Like most outer coverings or membranes, the

skin has a twofold nature: it is a protective shield and it facilitates the communication of meanings. Freud mentioned this nature in his discussion of the “mystic writing pad” (1925a [1924]), on which traces and signs are inscribed. The skin helps give the body its form and coherence. The human body can more readily assume a vertical posture because the skin protects and holds in the skeleton and musculature. The unity of the individual thus depends on the skin.

Certain areas of the skin (mucous membranes, erectile tissue, hair on the head, pubic hair, hollows) are especially sensitive to sexual arousal (in comparison with overall presexual skin-to-skin contact). Didier Anzieu has advanced the hypothesis of a fantasy of a skin common to mother and child, and on that basis he developed the idea of a skin ego—an idea that converges with Esther Bick’s notion of a psychic skin and Wilfred R. Bion’s concept of container/contained. For Anzieu, this fantasy of a common skin contributes both to the narcissistic foundation of the individual and to the anaclitic reinforcement of the sexual instinct.

In sadism and masochism, humans experience a mixture of pleasure and pain. Here the fantasy of a common skin is replaced by the fantasy of its being ripped off, which is necessary if the individual is to progress toward autonomy but also is a source of guilt feelings. Mother’s and child’s joint cathexis of the newborn’s skin is immediate and is sometimes a source of sexual pleasure. Indeed, if the mother does not spontaneously cathect this first contact, any of a large number of pathologies, ranging from asthma to autism, may result.

Psychodermatology has shown a correlation between flaws in the ego and skin disorders. The greater the impairment of the ego, the more seriously the skin seems to be affected.

DIDIER ANZIEU

*See also:* Adhesive identification; Anzieu, Didier; Bick, Esther; Body image; Dream screen; Erotogenic zone; Infant development; Infant observation; Isakower phenomenon, the; Masochism; Object; Protective shield; Psychic envelope; Skin-ego; Tenderness.

### **Bibliography**

Anzieu, Didier. (1990). Formal signifiers and the ego-skin. In Didier Anzieu et al. (Eds.), *Psychic envelopes* (Daphne

Briggs, Trans.). London: Karnac Books. (Originally published 1987)

———. (1989). *The skin ego* (Chris Turner, Trans.). New Haven, CT: Yale University Press. (Originally published 1985)

———. (1994). *Le penser: du moi-peau au moi-pensant*. Paris: Dunod.

Freud, Sigmund. (1905d). Three essays on the theory of sexuality. *SE*, 7: 123–243.

———. (1919e). “A child is being beaten”: a contribution to the study of the origin of sexual perversions. *SE*, 17: 175–204.

———. (1925a [1924]). A note upon the “mystic writing pad.” *SE*, 19: 225–232.

---

## **SKIN-EGO**

The term “skin-ego” designates a mental representation that the child forms on the basis of its experience of the surface of its body and uses to picture itself as the vessel of mental contents. The skin-ego belongs to the period in development when the psychic ego differentiates from the body ego on the practical level while remaining indistinguishable from it in the imagination. Intermediate between metaphor and concept, the notion of the skin-ego was worked out by Didier Anzieu and first presented in 1974.

According to Anzieu, the ego encloses the psychic apparatus much as the skin encloses the body. The chief functions of the skin are transposed onto the level of the skin-ego, and from there onto the level of the thinking ego. The functions of the skin-ego are to maintain thoughts, to contain ideas and affects, to provide a protective shield, to register traces of primary communication with the outside world, to manage intersensorial correspondences, to individuate, to support sexual excitation, and to recharge the libido. In brief, the skin-ego is an interface between inside and outside, and is the foundation of the container/contained relationship.

The skin-ego develops and is enriched by integration into the various envelopes of the sensorimotor system. It has two functional aspects, with one aspect focused on excitations of either internal or external origin and the other oriented toward communications with its entourage.

An important part of psychoanalytic work with borderline patients is the reconstruction of the earliest



phases of the skin-ego and their consequences for mental organization. This task calls on the techniques of transitional analysis.

DIDIER ANZIEU

*See also:* Adhesive identification; Body image; Ego; Infant development; Infant observation; Protective shield; Psychic envelope; Skin; Tenderness.

### **Bibliography**

Anzieu, Didier. (1974). *Le moi-peau*. *Nouvelle revue de psychanalyse*, 9, 195–208.

———. (1989). *The skin ego* (Chris Turner, Trans.). New Haven, CT: Yale University Press. (Original work published 1985)

---

## **SLEEP/WAKEFULNESS**

Unlike being awake, a vigilant consciousness, sleep corresponds to a withdrawal of cathexis from the outside world accompanied by a suspension of motor activity. It is an active phenomenon, and although at the beginning of life the opposition wakefulness/sleep is closely dependent upon that of satisfactions and needs; wishes, the capacity for regression, and the nature of the infant's relations to the mother soon modify this binary rhythm. In the waking state, excitation begins with sensory perception and in a sense traverses the psychic apparatus to emerge any motility; whereas during sleep the reverse happens: excitation passes from ideation to sensory perception, the dream.

Sigmund Freud approached the issue of waking and sleep through the analysis of dreams. In *The Interpretation of Dreams* (1900a), he advanced the hypothesis that dreams are the guardians of sleep. Unconscious excitation, linked to previous day's residues, is liable to disturb sleep. The dream is responsible for bringing this free energy under the control of the Preconscious; it diverts this energy, serves as a safety valve, and thus, with a minimal effort of vigilance, ensures sleep.

Freud did not modify this hypothesis, but later did flesh it out, most notably in the article "A Metapsychological Supplement to the Theory of Dreams" (1916–1917 [1915]), where he introduces the concept of a wish to sleep emanating from the ego, a veritable sleep drive that impels the sleeper to return to intrauterine

life. Sleep must be understood as a period of withdrawal toward primary narcissism: The mind renounces most of its acquisitions via a return to its developmental starting point as a way of reliving of its stay in the maternal body, some of the conditions of which are reproduced in sleep. It is as if a kind of inversion happens in sleep: The subject turns toward his or her inner world by almost totally withdrawing interest in the outer world of waking reality.

As Freud pointed out in the introduction to his "supplement," sleep, like mourning or being in love, can be considered the normal prototype of a pathological state. Regression and backward steps in development are observed. There are two types of regression. First, a temporal regression involving the organization of the ego, which, through this step backward, moves closer to the id. Second, a regression of libidinal development at the level of the drives which goes so far as to restore primary narcissism during sleep. Associated with a relaxation of repression during sleep, which is conducive to the emergence of the Id's drive energies, this state leads to the formation of dreams through hallucinatory wish-fulfillments. The dreamer is only interested in external reality to the degree it may threaten to bring about an end to the sleeping state by awakening.

After Freud, and until the early 1950s, this conception of the opposition sleep waking remained unchanged, and made enriched by concepts such as Bertram D. Lewin's 1949 postulation of the "screen dream," the result of introjecting the good maternal breast, which opens up "the dream space" and actualizes the matrix in which the dream's binding activity can occur. In 1953, when electroencephalographic images revealed the alternation between periods of slow sleep (also called non-rapid eye movement, or NREM sleep), which has a reparative function, and periods of paradoxical sleep (or REM sleep), in which dreams occur, attempts were made to distinguish between the somatic and psychic aspects of hypnic phenomena. As André Green emphasized, it appears to be essential to not transpose concepts from one domain to the other. However, it is both legitimate and productive to explore points of convergence between the two.

Authors do agree that sleep plays an organizing role in the case of both the physiological paradoxical sleep, and the psychological dreams. Dream phenomena seem to have binding functions: maintaining the continuity of sleep, connecting waking mental life to

sleeping mental life, and integrating lived experiences by binding them to libidinal needs. Masud Khan called this linking function the “capacity for dreaming,” and Didier Houzel suggested that this involves a process of stabilization, not in the form of a return to a fixed energy level of zero, but rather as a form of “structural stability,” that is, a dynamic equilibrium that assumes constant exchange with the environmental milieu.

PHILIPPE METELLO

*See also:* Alpha-elements; Amphimixia/amphimixis; Animal magnetism; Contact-barrier; Day’s residues; Development disorders; Dream; Ego feeling; Functional phenomenon; Hypnosis; Infantile omnipotence; Infantile psychosis; Isakower phenomenon; Mania; Manifest; Maternal care; “Metapsychological Supplement to the Theory of Dreams”; Mourning; Narcissistic withdrawal; Narco-analysis; Nightmare; Night terrors; *Outline of Psychoanalysis, An*; Perception-consciousness (Pcpt.-Cs.); Phobias in children; Projection; Somnambulism; *Thalassa. A Theory of Genitality*; Wish, hallucinatory satisfaction of a.

### Bibliography

- Freud, Sigmund. (1900a). The interpretation of dreams. *SE*, 4–5.
- . (1916–17f [1915]). A metapsychological supplement to the theory of dreams. *SE*, 14: 217–235.
- Houzel, Didier. (1980). Rêve et psychopathologie de l’enfant. *Neuropsychiatrie de l’enfance et de l’adolescence*, 28 155–164.
- Khan, Masud. (1972). La capacité de rêver. *Nouvelle Revue de psychanalyse*, 5 283–286.
- Lewin, Bertram D. (1949). Sleep, the mouth and the dream screen. *Psychoanalytic Quarterly*, 15, 419–434.

## SLIPS OF THE TONGUE

Slips of the tongue are errors involving the uttering (*Versprechen*), or hearing (*Verhören*), or writing (*Verschreiben*), or reading (*Verlesen*) of a word and which entail an involuntary parody of the word, assuming the word is known. This kind of slip is an ordinary occurrence but is structurally related to the paraphasias found in pathological conditions.

Freud became interested in slips and word play in 1890, and discussed them in his correspondence with Wilhelm Fliess. Both resemble dreams in that

they are part of normal behavior although they introduce an incongruous and, in the case of slips of the tongue and dreams, an involuntary element. Freud’s interest arose from his conviction that it would be impossible to understand psychopathological processes without having a clear notion of their relation to normal mental processes. It was in *The Psychopathology of Everyday Life* (1901b) that he provided the first and most complete discussion of slips of the tongue, but he discussed them again at length in the *Introductory Lectures on Psychoanalysis* (1916–1917a [1915–1917]).

In *The Psychopathology of Everyday Life*, Freud made use of an earlier, essentially functionalist work on slips of the tongue and reading errors (Meringer and Mayer, 1895), which he contrasted with his own theory. He eliminated two hypotheses: that of the “contamination” of the sound of one word by another and that of “wandering” speech images, which interested Freud to the extent that these disturbances were located below the threshold of consciousness (1901b, pp. 57–58). Using numerous examples, some of which are undeniably comical, Freud illustrated the way in which repressed drives return in the disturbance of language.

Slips during reading and writing are not structurally different from those that occur in hearing or speaking, and the same motives are found in both, either libidinal or hostile. But slips provide infinite forms of expression for those drives, while disguising them, and some require a complex effort of interpretation that presupposes familiarity with the life and memories of their author. In general, slips of the pen are not as readily noticed by their authors as slips of the tongue.

Freud sums up the character of slips of the tongue as follows in the *Introductory Lectures on Psychoanalysis*: “the suppression of the speaker’s intention to say something is the indispensable condition for the occurrence of a slip of the tongue.” However, the intention can be conscious or unconscious and still produce a slip. “In almost every case in which a slip of the tongue reverses the sense, the disturbing intention expresses the contrary to the disturbed one and the parapraxis represents a conflict between two incompatible inclinations.”

Slips are especially interesting when they lead us, in trying to understand them, to dissociate the sound (the signifier) from the meaning contained in the

word (the signified). The same was true for the most famous parapraxis made by Freud, forgetting the name Signorelli, to which Jacques Lacan (1966) devoted an entire essay. We find in both word play and jokes, as in slips or the forgetting of names, a complex dynamic and the same processes (displacement and condensation) that Freud showed to be operative in dreams, whose relevance for the study of the unconscious he recognized. Listening for slips of our own often has an immediate revelatory component, similar to that of the patient who hears himself say things that are unknown and yet familiar during the course of analysis.

SOPHIE DE MIJOLLA-MELLOR

*See also:* *Five Lectures on Psycho-Analysis*; Formations of the unconscious; *Introductory Lectures on Psycho-Analysis*; Language and disturbances of language; Linguistics and psychoanalysis; Parapraxis; *Psychopathology of Everyday Life, The*; Repression; Substitutive formation; Topology.

### **Bibliography**

Freud, Sigmund. (1901b). The psychopathology of everyday life. *SE*, 6.

———. (1916–1917a [1915–1917]). Introductory lectures on psycho-analysis. *SE*, 15–16.

Lacan, Jacques. (1966). *Écrits*. Paris: Le Seuil.

Meringer, Rudolf, and Mayer, Carl. (1895). *Versprechen und Verlesen: eine psychologisch-linguistische Studie*. Stuttgart: G.J. Göschen.

---

## **SMELL, SENSE OF**

Throughout his writings, Sigmund Freud made explicit reference to the role of the sense of smell in mental sexuality. “Olfactory substances...are disintegrated products of the sexual metabolism. . . . At time of menstruation and of other sexual processes the body produces an increased number of these substances and therefore of these stimuli,” he wrote to Wilhelm Fliess on January 1, 1896. Later, in his “Three Essays on the Theory of Sexuality” (1905d), he added that the repression of a coprophilic olfactory pleasure governs fetish choice: “Both the feet and the hair are objects with a strong smell which have been exalted into fetishes after the olfactory sensation has become unpleasurable and has been abandoned” (p. 155, note 3).

This inhibition of the sense of smell in humans, under the sign of the repression of the pleasure that it can bring, can play a major role in the development of certain neuroses; this is what Freud maintained in the case of the “Rat Man,” recorded in “Notes upon a Case of Obsessional Neurosis” (1909d). “The ‘organic’ repression of smell is also a factor in civilization,” he told his students at the Psychoanalytic Society of Vienna in a lecture delivered on November 17, 1909. Soon thereafter, in “On the Universal Tendency to Debasement in the Sphere of Love” (1912d), he posited this as a consequence of the fact that the human sensory organ had been raised up off the ground with the appearance of the upright stance. The coprophilic instinctual components then became incompatible with the esthetic demands of human civilization. He further elaborated this line of thought in “Civilization and Its Discontents” (1930a), where he speculated that the role of the olfactory sensations “was taken over by visual excitations, which, in contrast to the intermittent olfactory stimuli, were able to maintain a permanent effect. The taboo on menstruation is derived from this ‘organic repression’, as a defence against a phase of development that has been surmounted” (p. 99, note 1).

DOMINIQUE J. ARNOUX

*See also:* Coprophilia.

### **Bibliography**

Freud, Sigmund (1905d). Three essays on the theory of sexuality. *SE*, 7: 123–243.

———. (1909d). Notes upon a case of obsessional neurosis. *SE*, 10: 151–318.

———. (1912d). On the universal tendency to debasement in the sphere of love. *SE*, 11: 177–190.

———. (1930a). Civilization and its discontents. *SE*, 21: 57–145.

———. (1950a). Extracts from the Fliess papers. *SE*, 1: 173–280.

———. (1950c [1895]). *The origins of psychoanalysis: Letters to Wilhelm Fliess, drafts and notes: 1887–1902*. (Marie Bonaparte, Anna Freud, and Ernst Kris, Eds.; Eric Mosbacher and James Strachey, Trans.) New York: Basic Books, 1954.

Nunberg, Hermann, and Federn, Ernst. (1962–1975). *Minutes of the Vienna Psychoanalytic Society*. New York: International Universities Press.

## SMIRNOFF, VICTOR NIKOLAÏEVITCH (1919–1995)

The French psychoanalyst and neuropsychiatrist Victor Smirnoff was born on November 27, 1919, in Petrograd and died in Paris on November 5, 1995.

The child of doctors belonging to the social-democratic intelligentsia, he emigrated with his parents in 1921 after the Bolsheviks came to power. He spent some early years in Berlin before moving to Paris in 1929. After medical training, he worked as a psychiatrist under Georges Heuyer. In 1950, a grant from the Rockefeller Foundation took him to the United States on a fellowship in child psychiatry. There he came into contact with the pioneers of the Child Guidance movement, while his cultural interests and love of books led him into artistic and literary avant-garde circles.

Back in Paris in 1954, he undertook an analysis with Jacques Lacan at the suggestion of Wladimir Granoff. Much involved in the internal debates of the Société Française de Psychanalyse leading up to the split of 1963, Smirnoff was one of those, when that split occurred, who opted for rejoining the International Psychoanalytical Association and distanced themselves from Lacan's practical procedures while acknowledging the value of his teaching.

As a child psychoanalyst, Smirnoff took part in the organization of teaching at La Salpêtrière with Jean-Louis Lang and Daniel Widlöcher, and founded the psychotherapy clinic of the fifteenth arrondissement of Paris, known as "La Rue Tiphaine," where the psychoanalytical approach predominated. He was very active in the founding and running of the Association Psychanalytique de France (APF), contributing most importantly to training issues through his writings and his many control analyses. He was the association's president in 1975 and again in 1984. He took part in numerous conferences and built up the association's external relationships as much in France (notably with the Quatrième Group) as abroad. Smirnoff's friendship with Masud Khan in London and his desire for cultural expansion led to his translation into French of several essential texts, including Winnicott's "Transitional Objects and Transitional Phenomena" (1953) and Klein's *Envy and Gratitude* (1955).

Smirnoff's book *The Scope of Child Analysis*, first published in 1966, has been widely translated and frequently reprinted, and in 1992 it was completely revised. It is a basic work of reference in its field.

A member of the editorial board of the *Nouvelle Revue de psychanalyse*, Smirnoff also contributed many articles to other journals, among them *Topique*, *L'Esprit du Temps*, and *L'Inactuel*. The titles of his books attest to his eclecticism: *Et Guérir de plaisir*, *De Vienne à Paris*, *Une Ténébreuse Affaire*, and *Les Limbes de la répression* (written in collaboration with Marie-Claude Fusco, his partner of many years).

Victor Smirnoff contributed broadly to the development of the psychoanalysis of adults as well as that of children, and he never cordoned child analysis off, preferring to integrate it into an overall theoretical perspective.

He liked to refer to himself as *ein analytischer Wandersmann*, an analytic journeyman, and his personal itinerary indeed enabled him to maintain a cosmopolitan cultural openness and a wide acquaintanceship with a variety of analytical tendencies without wavering in his commitment to the APF and his position within it.

The legacy of Victor Smirnoff is that of a humanist for whom psychoanalysis was a true passion, a way of thinking, and indeed a way of living.

HÉLÈNE TRIVOUSS-WIDLÖCHER

*See also:* Association Psychanalytique de France; *Documents et Débats*; France; *Nouvelle Revue de psychanalyse*; Société française de psychanalyse.

### Bibliography

- Smirnoff, Victor. (1971 [1966]). *The scope of child analysis*. (Stephen Corrin, Trans.) New York: International Universities Press.
- . (1978). "... Et mourir de plaisir." *Nouvelle Revue de psychanalyse*, 17, 139–167.
- . (1979). De Vienne à Paris. Sur les origines d'une psychanalyse à la française. *Nouvelle Revue de psychanalyse*, 20, 13–59.
- . (1994). Autopresentation. In L. M. Hermmanns (Ed.), *Psychoanalyse in Selbstdarstellungen*, vol. 2. Sonderdr. Tübingen: Diskord.

## SOCIAL FEELING (INDIVIDUAL PSYCHOLOGY)

After long emphasizing feelings of inferiority and their consequences, Alfred Adler came to grant more and

more importance to the social feeling found in the notions of bonds or attachments that had been studied by such authors as René Spitz, John Bowlby, and Hubert Montagner.

At birth, the infant is extremely vulnerable because of its physiological immaturity. The mother-child relationship is thus vital for the newborn. In Adler's view, preestablished schemes are triggered in the interactions between mother and child: "The mother, taken as the nearest kin at the threshold of development of social feeling, is the source of the first impulses enjoining the child to enter into life as an element of the whole," he wrote. He thus considered the act of suckling the mother's breast as an act of cooperation. The socialization of the infant is a potentiality that represents an evolutionary acquisition of the species: "The evolutionary acquisition of maternal love is generally so strong in animals and human beings that it can easily outweigh the instinct for food and the sexual instinct."

Social feeling is not simply adaptation to the group, which itself can be a form of compensation for feelings of insecurity, as can be seen in cults or in totalitarian systems. This notion extends to both the political and economic dimensions of the object-relations that ensure the subject's autonomy. In the child, compensation for feelings of inferiority is modulated by the harmonious development of social feeling, in which the mother plays an essential role. According to Adler in *Problems of Neurosis: A Book of Case Histories* (1929/1964), it is she who "effects the first major and specifically human changes in the infant's behavior. Under her influence, the infant, for the first time, inhibits its desires and organic instincts and introduces delays and indirect methods into the pursuit of what it desires . . . it is also the mother who interests the infant in other people and enlarges its social circle."

This potentiality is not expressed automatically. The mother may reject the child from birth, as happens in puerperal psychosis. A fusional relationship, by contrast, will prevent any possibility of autonomy. René Magritte's painting *The Spirit of Geometry* illustrates this type of relationship, in which the mother can see herself as the son she would have liked to be. Fernando Botero's painting *Melancholy* represents one of its consequences. Compensation for feelings of inferiority mobilizes aggressive impulses, expressed in the form of antisocial behaviors that may develop in the direction of delinquency or criminality. It is the

development of social feeling that directs these aggressive impulses toward socialized behaviors or sublimation. In the neurotic, the aggressive behaviors are only masked. They are expressed in a systematic tendency toward devaluation.

In *The Practice and Theory of Individual Psychology* (1920/1951), Adler likened melancholia to paranoia. This is not surprising if we think in terms of compensation for feelings of inferiority and the degree of social feeling—that is, the relationship to the other in the two cases. The melancholic expresses a narcissistic breakdown resulting from a loss of love, for which he or she blames the other. The paranoiac hallucinates this feminine other, which enables him to idealize himself at the price of homosexual feelings of persecution, since he becomes both God and the wife of God. The annihilation of the other in the schizophrenic culminates in an all-pervasive self in a delusional world.

FRANÇOIS COMPAN

*See also:* Attachment; Inferiority, feeling of (individual psychology); Masculine protest (individual psychology).

### **Bibliography**

Adler, Alfred. (1951). *The practice and theory of individual psychology* (P. Radin, Trans.). New York: Humanities Press. (Original work published 1920)

———. (1964). *Problems of neurosis: A book of case histories* (P. Mairet, Trans.). New York: Harper and Row. (Original work published 1929)

---

## **SOCIÉTÉ FRANÇAISE DE PSYCHANALYSE**

The Société française de psychanalyse (SFP; French Society of Psychoanalysis) was born in 1953 out of the first split in the French psychoanalytic movement. The reasons for its creation, already present within the Société psychanalytique de Paris (Paris Psychoanalytic Society), involved disagreements about the criteria for the selection and training of future analysts. The conceptions of Sacha Nacht, among other points of disagreement, were concretized in the statutes of the new Institut de psychanalyse (Institute of Psychoanalysis), and these were opposed by Jacques Lacan. At the administrative session of the meeting of the Paris Psychoanalytic Society on June 16, 1953, Lacan resigned after his presidential mandate was withdrawn in favor of Vice President Daniel Lagache. Lagache then

announced his own resignation. Also resigning were Françoise Dolto and Juliette Favez-Boutonier, soon followed by Blanche Reverchon-Jouve. Lacan joined forces with them to found the SFP, which André Berge and George Mauco also joined, though they concomitantly remained members of the Paris Psychoanalytic Society.

During the ten or eleven years of its existence, the SFP proved to be singularly active, productive, and open to other disciplines under the influence of, in particular, Lagache, Lacan, Dolto, Favez-Boutonier, and Georges Favez, seconded by the “troika” of Serge Leclaire, Vladimir Granoff, and François Perrier, who were to play a major role. Among the successes of the society, especially noteworthy are the Royaumont Colloquium of 1961 and the creation in 1956 of the journal *La psychanalyse*, which was active until 1964, eight issues later.

Meanwhile, a setback came to light. The founders of the SFP did not realize that by leaving the Paris Psychoanalytic Society, they were also, ipso facto, relinquishing their membership in the International Psychoanalytical Association. Thereafter, successive presidents of the society—Lagache, Lacan, and Angélo Hesnard—repeatedly approached the International Psychoanalytical Association to get the association to recognize the SFP.

The history of the second split, for anyone who did not actually experience it, is difficult to reconstruct. Those in charge of the future Association psychanalytique de France (French Psychoanalytic Association), except perhaps for Vladimir Granoff in veiled form, have not given their versions of events, while those in rival societies, except for Alain de Mijolla, gave only approximate glimpses often lacking in objectivity, or even obviously biased, imprecise, and polemical.

The reasons for this second split appear to be twofold and intertwined: recognition of the SFP by the International Psychoanalytical Association and the issue of training, in particular, training analysis. After a defeat on the former goal at the 1959 Congress of the International Psychoanalytical Association in Copenhagen, which had dispatched an investigative commission, the next congress, in Edinburgh in 1961, recognized the SFP with the provisional status of a study group and named Lagache, Leclaire, and Favez-Boutonier as members at large, but it combined these decisions with a series of “recommendations”—all

technical in nature, dealing with training, and challenging the practices of Lacan and Dolto.

The approach of the Stockholm congress in 1963, which was supposed to rule on the request for affiliation, sparked intense discussion, both within the SFP and with members of a new investigative commission. These discussions, not always devoid of misunderstanding or naïveté, mainly involved attempts at reconciliation, notably through the mediation of Granoff and Leclaire. A motion for relative reconciliation was thus presented to the International Psychoanalytical Association on July 11, 1963, by six of Lacan’s analysands, dubbed the “motionnaires”: Piera Aulagnier, Jean-Louis Lang, Jean Laplanche, Jean-Bertrand Pontalis, Victor Smirnoff, and Daniel Widlöcher; with the support of Didier Anzieu and Jean-Claude Lavie (also analysands of Lacan) and Granoff. But the executive committee of the association, though it added Granoff to the previously recognized members at large, further hardened its requirements, demanding that Lacan and Dolto be excluded from all training activity.

From then on, the split gradually solidified between the two groups: one around Lacan, with Leclaire and Perrier, and the other with Lagache, Favez-Boutonier, Favez, and Berge. The representatives of the first group, until then in the majority in the administration of the SFP, resigned in October 1963 and in December created, around Jean Clavreul, a “psychoanalysis study group” not recognized by the SFP. The second group, which became the majority in November, was recognized by the International Psychoanalytical Association only as a “French study group.” The split was then inevitable. The statutes of the Association psychanalytique de France were registered on June 9, 1964, and Lacan, on June 21, announced the founding of the *École française de psychanalyse* (French School of Psychoanalysis), which quickly renamed itself the *École Freudienne de Paris* (Freudian School of Paris). In January 1965 representatives of the two societies announced the dissolution of the SFP, whose membership at the time included 20 permanent members, 25 associate members, 4 corresponding members, and 80 candidates.

JEAN-LOUIS LANG

See also: Association psychanalytique de France; Congress of French-speaking psychoanalysts from

Romance-language-speaking countries; École freudienne de Paris (Freudian School of Paris); France; Psychanalyse, La; Société psychanalytique de Paris and Institut de psychanalyse de Paris; Splits in psychoanalysis.

### **Bibliography**

Editors of *Ornicar?* (1977, December). Sur la passe. *Ornicar?*, 12–13.

Lang, Jean-Louis. (1996). La scission de 1963. *Cliniques méditerranéennes*, 49–50, 73–77.

Mijolla, Alain de. (1996). La scission de la Société psychanalytique de Paris en 1953: quelques notes pour un rappel historique. *Cliniques méditerranéennes*, 49–50, 9–30.

———. (1988). Splits in the French psychoanalytic movement between 1953 and 1964. In R. Steiner and J. Johns (Eds.), *Within Time and Beyond Time* (pp. 1–24). London: Karnac.

Roudinesco, Élisabeth. (1990). *Jacques Lacan & Co.: A history of psychoanalysis in France, 1925–1985* (Jeffrey Mehlman, Trans.). Chicago: University of Chicago Press. (Original work published 1986.)

---

## **SOCIÉTÉ PSYCHANALYTIQUE DE GENÈVE**

The Geneva Psychoanalytic Society was founded in September 1920, its creation being announced in the *Internationale Zeitschrift für Psychoanalyse* (1921), although it never figured among the component societies recognized by the International Psychoanalytic Association. It was founded shortly after the Swiss Psychoanalytic Society, which was constituted in Zurich in 1919.

The Geneva Psychoanalytic Society brought together both physicians and non-physicians, as well as people who practiced psychoanalysis and others who took an interest in it without practicing it. Its president was Édouard Claparède, physician and professor of psychology at the science faculty of Geneva University. Although not a psychoanalyst, Claparède took a great interest in psychoanalysis from 1906 onwards and regularly kept the readers of *Archives de psychologie* up to date with Freud's latest discoveries. In 1920 he wrote the preface to the first French translation of Freud's *Five Lectures on Psychoanalysis* (1910a), which he first published in the *Revue de Genève*. Alongside Claparède we find Pierre Bovet, director of the Jean-Jacques Rousseau Institute, as well as Henri Flournoy and Charles Odier, who were among the first to practice psychoanalysis, and Raymond de Saussure,

who joined the society a little later. Also active in the society was Dr. Ferdinand Morel, who later abandoned psychoanalysis, Dr. William Boven, from the Lausanne medical faculty, and Sabina Spielrein. One of Jung's former patients, Sabina Spielrein came to Geneva in 1920 and was Jean Piaget's analyst. We know little enough about the life of the society or how it came to be dissolved. It is easy to imagine that after 1928 the Swiss Psychoanalytic Society, reorganized by its new president, Philipp Sarasin, had a greater attraction for psychoanalysts in French-speaking Switzerland.

JEAN-MICHEL QUINODOZ

See also: Claparède, Édouard; Flournoy, Henri; Odier, Charles; Sarasin, Philipp; Spielrein, Sabina.

### **Bibliography**

Roch, Marcel. (1980). À propos de l'histoire de la psychanalyse en Suisse romande. *Bulletin de la Société suisse de psychanalyse*, 10, 17–30.

Saussure, Raymond de. (1967–68). L'histoire de la psychanalyse en Suisse romande. *Bulletin de la Société suisse de psychanalyse*, 6, 1–4.

---

## **SOCIÉTÉ PSYCHANALYTIQUE DE MONTRÉAL**

Around 1968 and 1969 it became obvious that for linguistic and geographic reasons, among others, sections based on a federal model were needed within the Canadian Psychoanalytic Society. In the Francophone community, the growing number of candidates and the emergence of a strong nationalist sentiment meant that the training program in English had become an anachronism. In and around Toronto, with the increase in the number of psychoanalysts between 1959 and 1969, there was no longer any reason why candidates should have to travel every week from Toronto to Montreal for their training, as had been the case for ten years.

The Canadian Psychoanalytic Society thus created Francophone and Anglophone sections for Montreal, called respectively the Société psychanalytique de Montréal (SPM) and the Canadian Psychoanalytic Society/Quebec English. A third section was created for Ontario: Ontario Branches. As early as May 1965, the Canadian Institute of Psychoanalysis communicated its intention of setting up a training program in

French, beginning in 1967. Initially, the three sections used the same training program that the institute had established in 1959, which corresponded to the program used by the British Institute of Psycho-Analysis. This four-year program consisted of conferences; clinical, technical, and theoretical seminars; and three supervised analyses. Considering the program to be too classical, the new wave of French-speaking psychoanalysts trained in Paris in the 1960s began to question it toward 1970.

In September 1969 a few Paris-trained French-speaking psychoanalysts created the *Groupe français de Montréal* (Montreal French Group). Some English-speaking colleagues quickly saw this as a desire for separation that was inspired by the political movement *Souveraineté-Association*. After the initial euphoria, the new group quickly found itself confronted with the harsh political realities of the Canadian Psychoanalytic Society: the requirements, programs, and traditions of the Canadian Institute of Psychoanalysis were very different from what they had known in Paris, and they aspired to greater autonomy than their Anglophone colleagues were willing to grant them. The *Société psychanalytique de Montréal* diverged from the other two sections of the society mainly over training issues: differences in the teaching program, a refusal to allow the institute to intrude in personal analyses, a non-evaluative concept of training, ongoing seminars that could be run by nontrainers, and above all, the creation of the category of authorized analysts, which allowed nontrainer analysts to analyze candidates after five years of membership.

It is important to point out that as early as 1965 those concerned had agreed on how the three Canadian sections would be constituted, and that in the winter of 1965/1966 the three future sections had established a common ground. At this stage the Francophone members of the institute expressed their fears that “due consideration for the needs of the sections in terms of geographic and cultural autonomy was hardly compatible with the maintenance of organizational unity.” Nevertheless, in 1968 the three sections of the institute were created, and in 1969 those of the society were created. On October 9, 1969, the members of the Francophone group unanimously adopted the name *Société psychanalytique de Montréal* (Psychoanalytic Society of Montreal), although the name was not officially adopted by the Canadian Psychoanalytic Society until 1972. At this point some members favored a

complete separation in the Canadian Psychoanalytic Society, while others feared the isolation that such an early separation might lead to. Another attempt to launch the idea of a separation was again rejected by the members in the mid-1990s.

In the fall of 1967, the first monolingual French training program got its start. There were 8 analysts and 9 students. Twenty-one years later (1988), 95 students had completed their training in French. The first elected council of the *Société psychanalytique de Montréal* held its inaugural meeting on November 24, 1969. Dr. Jean-Louis Langlois was the first president. During this meeting Roger Dufresne put forward the idea of ongoing seminars with a view to enhancing collaboration between the institute and the society, and the members voted in favor of an annual scientific colloquium to be held every spring, an idea that was dear to André Lussier.

The teaching at the institute was initially didactic and continued the tradition of the 1959 program. This situation continued until 1972, when ongoing open seminars directed by both members and nonmembers of the institute were made available to candidates. Work in such small groups best fostered the free and open exchange of ideas. The great originality of these seminars was that they consisted of older members, younger members, and students. The only requirement retained was study of Freud's texts, spread out over four years, the training being dispensed by any member who expressed the desire to do so, whether a training analyst or an ordinary member. In addition, stress was placed on supervision (which was seen as more helpful than evaluation) and particularly on the training analysis, later considered to be the core of training. For this reason the position of reporting analyst was abolished, in order to protect the transference of the training analysis from third-party institutional interference. In this context, the training analysis was considered a personal analysis in which the desire to become an analyst also had to be analyzed. As part of the commitment of candidate analysts, as soon as candidates are accepted, they are required to attend all scientific meetings.

This teaching model became the obvious choice among alternatives as the result of debate at international pre-congress meetings on training, the influence of the Francophone analytic groups, and the workshop “The current situation for psychoanalysis,” launched in February 1970 by four Paris-trained members: Jean



Bossé, Claude Brodeur, Roger Dufresne, and Jean-Louis Saucier. Every second Wednesday they reflected on the nature of the analytic process and on the relationships between psychoanalysis and society, psychoanalysis and medicine, psychoanalysis and psychoanalytic institutions, free treatment and direct payment by insurers, training analysis and personal analysis, training seminars and ongoing seminars, and supervision as assistance versus evaluation. Also important was the first annual scientific congress of the French section, in June 1970, on the theme “the transmission of psychoanalysis.” The reflections arising from these debates led to many policies later adopted at administrative meetings. Even in 2005 the structures of the Société psychanalytique de Montréal remain profoundly marked by the principles that made their appearance at that time.

Early on, the society found itself confronted with considerable challenges, particularly the establishment of the Quebec social security system. Psychoanalyst-physicians in Quebec had to decide on the medical or nonmedical character of psychoanalysis. At stake was the issue of state payment for analyses conducted by psychiatrists and whether there would be two categories of analysts: analysts with medical degrees and those without. Sufficiently aware of the obstacles that arise when the state interferes in treatment and because a second-class status would make it practically impossible for nonphysicians to practice, the French and English Quebec societies, after intense debate, bravely affirmed the nonmedical character of psychoanalysis. The Toronto Psychoanalytic Society made the opposite decision. This is one indication that many Canadian analysts, as well as many American analysts, considered psychoanalysis a subspecialty of psychiatry, and it provides a glimpse of the cleavage existing in the Canadian Psychoanalytic Society with regard to the nature of psychoanalysis.

The questioning was then extended to society-institute relations, to training in accordance with the Anglo-Saxon model (so different from the prevalent models in Paris), and to the centralizing influence of the Canadian Psychoanalytic Society, which delegated only the scientific program to sections, without providing any financial resources to organize scientific life or set up a library. During the three decades from 1967 to 1997, the financing and administration of the sections was partly autonomous and partly centralized. Up until the foundation of the Société psychanalytique de Montréal, all theoretical references were to works in

English, with the exception of Freud’s works, which had to be read in English. The authors to whom Paris-trained analysts referred seemed to be unknown. The difficulty of establishing a French-language library was the beginning of a long and arduous struggle toward administrative and financial autonomy for the sections—a struggle that reached its conclusion only in 1997 when they acquired complete autonomy in these domains.

The Société psychanalytique de Montréal was distinctly different from other Canadian psychoanalytic societies. First, it was open to diverse influences, but gravitated toward French psychoanalytic thinking. When founded in 1969, the society had 29 members, 13 of whom had trained in Paris, 3 in the United States, 1 in London, and 12 in Montreal. Second, it choose an open training program, unlike what was practiced in the other sections of the Canadian Psychoanalytic Society and in the United States. The Société psychanalytique de Montréal, like the Canadian Psychoanalytic Society/Quebec English, is the fruit of diverse contributions arising from several theoretical models following in the wake of Freud. As a result, points of dissent and rupture tend to be situated more around language and culture, or around questions of training and modes of transmitting psychoanalysis, rather than around schools and the theoretical rifts that found them. From a long cohabitation with English-speaking analysts, Francophone analysts have developed the arts of compromise and gentlemen’s agreements, which have enabled them so far to avoid the rifts that are so common in Europe. As a North American Francophone society, the Société psychanalytique de Montréal serves as a point of convergence between European and American influences.

The Société psychanalytique de Montréal and the Canadian Psychoanalytic Society/Quebec English share the same building, which is also the headquarters of the Canadian Psychoanalytic Society. Relations between the two sections have always been characterized by respect and courtesy. Some members of each section are greatly esteemed by those of the other. Ever since the establishment of the sections and in varying ways, there have always been candidates on either side who have gone to the other side for their supervision or analysis, just as from time to time some analysts, after their training, request transfers to the other section. Moreover, members of the French section attend

meetings of the Anglophone section more frequently than the converse.

In spite of all this, apart from differences over common issues that were resolved for a time, relations between the two sections have long been characterized by mutual incomprehension and distance. Though not applicable to all members, the most tenacious preconception is that the Francophones indulge in abstract philosophy and literature and are not clinically oriented, whereas the Anglophones are pragmatically engaged in psychiatry and psychology, but not psychoanalysis. These prejudices have not, however, prevented friendships and collaborations from developing between individuals. Moreover, by incarnating an external enemy against which cohesion had to be maintained, each society may perhaps have enabled the other to avoid internal divisions. Scientific relations with other sections are more tenuous. Even so, some members of the Société psychanalytique de Montréal are regularly present at the annual scientific congresses of the Canadian Psychoanalytic Society and play an active part in the different study committees of the umbrella organization.

Thirty years after its foundation, the Société psychanalytique de Montréal has more than quadrupled in size despite the inevitable departures. The society prides itself on having opened its doors to nonphysicians, which has enriched it with points of view from associated disciplines and consequently has enabled it to get a clearer grasp of the specific nature of psychoanalysis. The ongoing seminars of the society have exceeded the wildest hopes. They have enabled analysts, after their training is complete, to remain in contact with reflective networks of analysts of all ages. These seminars also serve to counterbalance the more impersonal relations that set in as the society grew larger. Analysts thus have a forum where they can discuss questions that arise in individual practice. Unfortunately, the society has not succeeded in providing an analytical presence in Quebec's main regions outside of Montreal and Quebec. As a result, the society has often been reproached for being closed.

In spite of the risks involved, the Société psychanalytique de Montréal, always supposing that its window onto society is compatible with its nature, has sought in the 1990s to maintain a higher social profile. The public conferences (Françoise Boulanger conferences, Julien Bigras roundtables), the open-house days, the project for an institutional psychoanalytic clinic, and

the creation of a permanent communications committee are all signs of a new desire to be open to society.

JACQUES VIGNEAULT

### **Bibliography**

- Editors of *Frayages*. (1987). *La naissance de la psychanalyse ... à Montréal. Frayages*, 3.
- Parkin, Allan. (1987). *History of psychoanalysis in Canada*. Toronto: Toronto Psychoanalytical Society.
- Société psychanalytique de Montréal. (1992). *Bulletin de la SPM*.
- . (1994). *Bulletin de la SPM*.
- Vigneault, Jacques. (1993). Transferts et déplacements: fondements de psychanalyse en Amérique du Nord. *Trans*, 3, 223–237.

## **SOCIÉTÉ PSYCHANALYTIQUE DE PARIS AND INSTITUT DE PSYCHANALYSE DE PARIS**

From its creation in 1926 until the split of 1953, the history of the Société psychanalytique de Paris (SPP; Paris Psychoanalytical Society) practically coincides with the history of psychoanalysis in France, and since 1954 the society's history has been indissociable from that of the Institut de psychanalyse de Paris (Paris Institute of Psychoanalysis).

“On November 4, 1926, Princess George of Greece, née Marie Bonaparte, Mme. Eugénie Sokolnicka, Professor Angelo Hesnard, the two Drs. Allendy, A. Borel, R[ené] Laforgue, Rudolph Löwenstein, Georges Parcheminey, and Édouard Pichon founded the SPP. The goal of this Society is to bring together all the French-speaking doctors qualified to practice the Freudian therapeutic method and to give doctors who wish to become psychoanalysts the opportunity to undergo the training analysis that is indispensable to the practice of Freud's method.”

This was a fairly heterogeneous group of young psychiatrists (their average age was around thirty) who, after founding the group Évolution psychiatrique (Psychiatric Development) in 1925, were led to join forces with the non-physicians Eugénie Sokolnicka, a Polish-born emigrant; Freud's “legitimate representative” Marie Bonaparte, the main instigator of the organization (de Mijolla, 1988); and another emigrant of Polish origin, Rudolf Löwenstein, who had trained at

the Berliner Psychoanalytisches Institut (Berlin Psychoanalytic Institute) and would become their main training analyst. Although they were united around projects such as continuing the conferences of French-speaking psychoanalysts, initiated in August of the previous year, the launching of the *Revue française de psychanalyse* in 1927, or the formation of a Linguistic Commission for the unification of French psychoanalytic terminology, there were also a number of points of opposition that were exacerbated over the years. Two clans formed: One was made up of those who were faithful to Freud and to the International Psychoanalytical Association (IPA); the other consisted of those who, like Angélo Hesnard, or following Professor Henri Claude, who brought them together in his ward, were hostile to non-physicians. The latter group wished to invent a psychoanalysis purged of the “Germanic mystique,” adapted to the needs of psychiatry and, tellingly, to the French “mentality”—Édouard Pichon, after all, was a disciple of Charles Maurras of the right-wing Action Française.

The two factions nevertheless continued to pull in tandem, for better or for worse, until World War II, ensuring the publication of the *Revue*, the translation of a number of Freud’s works (many of these thanks to the efforts of Marie Bonaparte), and the introduction into the medical community of Freud’s theories, which had been rendered more than a little suspect by the vogueish effects that had accompanied their dissemination in France by way of the literary milieu of the *Nouvelle revue française* and surrealism.

When the society was created, René Laforgue was elected president (a post he held until 1930), Eugénie Sokolnicka vice president, and Rudolph Löwenstein secretary-treasurer. The first permanent member to be elected was Dr. Henri Codet, on December 20, 1926; Anne Berman, at the time Marie Bonaparte’s secretary, became the first regular member on January 10, 1927. Ernest Jones came to give a lecture on April 5 (Hanns Sachs was invited to lecture in 1928 and Hanz Prinzhorn in 1929, despite Édouard Pichon’s opposition to those who did not speak French), and in May it was announced that “Messieurs Codet, de Saussure, and Odier will be known as founding members.” In 1927 Sacha Nacht, as a “guest of the society,” presented “Quelques considérations sur une psychanalyse chez une schizophrène” (Some considerations on a psychoanalysis of a schizophrenic woman); he was elected to [membership on January 17, 1928, and to permanent

membership on October 21, 1929. A week later, the Second Congress of French-speaking Psychoanalysts discussed Charles Nodier’s report, “Obsessional Neurosis,” the first official manifestation of the SPP and the first in the long series of these Conferences (later called Congresses) that continue even today to bring together Europe’s French-speaking psychoanalysts and to put on their agenda various theoretical and clinical aspects of Freudian psychoanalysis: “Psychoanalytic Technique” by René Laforgue and Rudolph Löwenstein in 1928 and Eugénie Sokolnicka’s presentation on the same topic, also in 1928; “Les processus de l’autopunition en psychologie des névroses et des psychoses, en psychologie criminelle et pathologie générale” (The processes of self-punishment in the psychology of the neuroses and the psychoses, in criminal psychology and general pathology) by Angélo Hesnard and René Laforgue in 1930; “L’hystérie de conversion” (Conversion hysteria) by Georges Parcheminey in 1931; “La psychanalyse et le développement intellectuel” (Psychoanalysis and intellectual development) by Jean Piaget in 1933; and “Le masochisme, étude historique, clinique, psychogénétique, prophylactique et thérapeutique” (Masochism: a historical, clinical, psychogenetic, prophylactic, and therapeutic study) by Sacha Nacht in 1938, the last lecture before the war.

After discussions and revisions, which would often recur over the years, the statutes of the society, whose headquarters had been established at René Laforgue’s home, were officially registered on October 25, 1927. In 1928 the bureau saw Angélo Hesnard become vice president, Marie Bonaparte treasurer, and René Allendy secretary. In 1929, however, there was a crisis, because, as Laforgue wrote to Freud on October 26: “A very active minority of our group is against the International Psychoanalytical Association and against lay analysis.” The conflict was resolved, but at the price of Laforgue’s giving up the presidency.

On January 10, 1934, the first Institut de psychanalyse de Paris was inaugurated. Marie Bonaparte, who had made its creation possible, was named director. On July 13, 1937, Daniel Lagache was elected to permanent membership, as Jacques Lacan would be in December 1938.

Beginning in 1933 the issue arose of what welcome should be extended to analysts fleeing the threat of Nazism, first from Germany and then from other Central European countries. It was essentially Marie Bonaparte, supported by Anne Berman, René Laforgue, and

Paul Schiff, who pleaded in favor of these analysts and attempted to integrate them into a society whose nationalistic members—together, moreover, with the French population as a whole—wanted it to be more closed. René Spitz and Heinz Hartmann, among others, passed through Paris before emigrating across the Atlantic. The SPP offered no official welcome to Freud when he passed through Paris on June 5, 1938.

The beginning of the war in 1939 did not stop courses at the Institut de psychanalyse, but the German occupation brought all psychoanalytic activity to a halt. The *Revue française de psychanalyse* ceased publication.

The society's activities gradually resumed after 1946 under the presidency of John Leuba. In the wake of Sacha Nacht, wreathed in the laurels of his resistance activities, there appeared newcomers such as Serge Lebovici, the first among those who would soon form the core of his team. Discredited by his attempts at collaboration with Matthias Göring, René Laforgue was excluded, and those who had undergone analysis with him—Juliette Favez-Boutonier, Françoise Dolto—suffered from this discrediting. However, the *Revue française de psychanalyse*, published by the Presses Universitaires de France, was reborn in 1948, the same year that the Eleventh Congress of French-Speaking Psychoanalysts in Brussels saw joint presentations by Sacha Nacht and Jacques Lacan: “L’aggressivité en psychanalyse” (Aggressiveness in psychoanalysis).

This theme presaged the conflicts that would crystallize around the issue of the training of new candidates, for Freud had again become fashionable in France, and the prisonlike structures of psychiatric institutions were being called into question by young psychiatrists. The SPP, which no longer knew where to hold meetings, had no library and no means of accepting students (there were seventy of them in 1950), and needed to establish premises for its operations. Sacha Nacht was elected president in 1949 and took in hand the future of the institute of psychoanalysis that everyone was determined to create. Although there was unanimity around the contents of the “Rules and Doctrine of the Commission on Teaching Delegated by the SPP,” drafted by Sacha Nacht and Jacques Lacan in September 1949, Daniel Lagache quickly became opposed to its authoritarian views and convinced a number of René Laforgue’s analysands, and then Lacan himself, to take his side. After three years of internecine struggles, Lacan was shown, on June 16,

1953, to have minority support as president of the SPP and resigned, while Daniel Lagache announced the founding of the Société française de psychanalyse (SFP; French Society of Psychoanalysis). Meanwhile, legal proceedings filed in 1950 against a non-physician colleague, Mrs. Clark-Williams, for the “illegal practice of medicine,” had established that a psychoanalytic society had a the collective responsibility to civil society. There were thus ample arguments to support Nacht’s imposition of strict, medically-oriented standards for training, applying the criteria of co-option defined by the IPA with regard to the number, frequency, and duration of sessions in the “training analysis” or the “supervised treatments” required of candidates.

For some thirty years, issues related to training took center stage in French psychoanalysis; at the same time, they stimulated unprecedented emulation in the theoretical, clinical, and institutional creativity of members of an SPP that was spurred on by rivalry with the SFP and later, increasingly, by the renown of Jacques Lacan and the growing number of his students.

The June 1954 inauguration of the Institut de psychanalyse, headed by Nacht until 1962, created a split that was not transcended until 1986. Although the SPP, in the eyes of the IPA, remained the sole representative of psychoanalysis in France until 1965, it was then reduced to the rank of a mere scientific society, without decision-making powers with regard to training policies or the dissemination of Freud’s theories. To be sure, the society still played a determining role in the organization of “Romance-language congresses” (a new appellation suggested by Lacan before the split, and of which Pierre Luquet became permanent secretary in 1956), on commissions, and in international congresses, but the dynamism of the society was concentrated around the team that directed the Institut de psychanalyse (Serge Lebovici, René Diatkine, Maurice Bénassy, Henri Sauget). They formed the core of the “Commission on Teaching,” whose members were co-opted from among the permanent membership, and where choices and decisions were made regarding candidates for various posts. While dual membership in both societies may have been mandatory, the importance given to the criteria for training and selection was such that soon the public no longer spoke of the “Society,” but instead referred to the group as “the Institute.”

Sacha Nacht’s leadership style was autocratic, and he implemented a number of changes that remained

after his departure, such as the professional development seminar for analysts from the provinces. His students and partisans were quickly elected to permanent membership to replace those who had left as a result of the split: Béla Grunberger in November 1953, Michel Fain and René Held in early 1954, and others thereafter. Above all, Nacht created a mindset and a way of conceiving of psychoanalysis that are evident in the works published during his tenure, such as *La Psychanalyse d'aujourd'hui* (Psychoanalysis Today, 1956). At the Twentieth Congress of the IPA in Paris at the end of July 1957, he was elected vice president of that organization. His work was a central reference in almost all the scientific papers presented in meetings of the SPP, and he was the preferred target for attacks by his former friend Lacan and his followers, although Maurice Bouvet, before his death in 1960, was another such victim, particularly with regard to his work on object relations. In 1962 a prize was created in memory of this analyst; until 1978, when it went to Micheline Enriquez, a member of the Quatrième Groupe O.P.L.F., it was awarded only to analysts from the SPP.

During the 1960s new names appeared in the ranks of the permanent membership, such as Conrad Stein, Serge Viderman, Robert Barande, and André Green, who would represent the next generation of the SPP and build bridges of scientific communication with psychoanalysts from “enemy” organizations. In 1962 a minor revolution displaced Sacha Nacht from the leadership of the institute in favor of Serge Lebovici, assisted by Michel Fain, with Francis Pasche responsible for the presidency of the society. The autocracy of Nacht and his restricted Commission on Teaching gave way to an oligarchy, that of the “permanent members” (there were thirty of them in 1963). By way of elections held within the society, this group for a number of years maintained their control over what was always the living part of the society, the institute and its Commission on Teaching, on which they all secured ongoing membership in 1965. This was also the terrain of after-conflicts, since over time the play of politics led to the election of about one-third dissenting voices, which, although they never managed to impose the liberal reforms they wished to promote, gradually caused movement in the ponderousness of this large, two-headed institution.

The 1964 election to permanent membership of Evelyne Kestemberg, the first nonphysician since the times of Marie Bonaparte (who had died in 1962), provided proof of the thorough expunging of the poli-

cies of Sacha Nacht, who had always opposed this. Others followed, such as Janine Chasseguet-Smirgel and Joyce McDougall in 1965, and then Salem Shentoub in 1966, providing the SPP with the openness and diversity that gradually came to characterize it and cause it to lose its monolithic aspect. It was also the year of the rapprochement between the society and the Association psychanalytique de France (APF; Psychoanalytical Association of France), which was recognized by the IPA in July and in 1970 fully participated for the first time in a Congress of Romance-language-speaking Psychoanalysts, with a presentation by Didier Anzieu entitled “Éléments d’une théorie de l’interprétation” (Elements of a theory of interpretation).

The founding in October 1966 of the European Federation of Psychoanalysis, in which societies’ representation was proportionate to their membership base, led to a broadening of the SPP, the consequences of which were crucial for its development. This was the creation, in November 1967, of the category of “affiliated members,” which was to serve as a screening stage between the completion of the curriculum at the institute and election to full membership in the society upon submission of a clinical thesis, which henceforth was the only path of access to membership. This new category would not be the last thing to agitate the tumultuous meetings of May 1968, where institutional constraints were called into question within the Commission on the Degree Program and Hierarchy—although without immediately producing any spectacular modifications. A January 1969 report by Jean-Luc Donnet on behalf of this commission set forth a proposed degree program, the first in a long series, for discussions, counterproposals, meetings, conflicts, and open letters addressing the problems of training which thereafter took center stage in most of the meetings and general assemblies of the SPP and the institute.

A new reform of the statutes promoted by Pierre Marty, who was elected president in 1969, that aimed to create an administrative college was voted in on June 16, 1970, on the condition that the problem of the “affiliated members” be set aside. Indeed, this category considerably changed the numerical ratio of the membership in an association where, by law, each dues-paying member was supposed to have administrative power and the right to vote: there were 43 affiliated members when the category was created and 81 in 1969, but there were 214 by 1986, while during

the same time period the ranks of the regular members grew from 44 to 49 and then 79, and the number of permanent members grew from 35 to 38 and then to 66. The college thus represented a first step toward expanding institutional responsibilities over the three categories of members, even though initially only the regular members were allowed to play a role, for example, on the candidature commissions and the election of their peers. The area of training analysis (in French, *analyse didactique*), although the word “didactic” discreetly disappeared from usage, like the election of permanent members, remained a closed field reserved only for members of the Commission on Teaching. Only twenty-four years later, on September 27, 1994, would the permanent members modify the conditions for admission to the degree course and agree to allow any person who had been in analysis for more than three years with a member of the SPP to ask to be received by the Commission on the Degree Program. This measure put an end to the struggle that had underlain all the episodes of administrative turbulence that had beset the society and the institute from 1970.

A new attempt to reform the statutes to integrate the affiliated members into the institute failed in 1974 because of a negative vote from the permanent members, among whom a conservative majority continued to prevail. A gentleman’s agreement was nonetheless adopted that provided for a three-year trial of a board of directors made up of the three categories of members, but this was followed by a series of discussions and votes that were aborted because one or several categories did not have a quorum.

In 1974, René Major had to resign in a climate of hostility from his post as director of the institute because he was not French and his naturalization remained blocked for an unusually long time. André Green, who succeeded him, proposed in a letter of December 19, 1974, an idea that would run its course, that of the “merger of two associations into a single one, with that society taking responsibility the totality of our psychoanalytic life in the three institutional sectors related to it: the scientific sector, the training sector, and the therapeutic sector, which currently go by the names of the Société psychanalytique de Paris, the Institut de psychanalyse, and the Centre de consultations et traitements psychanalytiques [Center for Psychoanalytic Consultation and Treatment].”

This idea was taken up anew by Pierre Luquet, president of the SPP after 1975, but nothing was settled,

and the conflicts intensified to the point where in 1979 another split might have occurred had the dissidents been united around anything other than their opposition to the majority in place. The proposal for a training program with two tracks, one “classic,” proposed by Serge Lebovici, and the other more “liberal,” supported by Serge Viderman, was presented and in turn buried. The institutions held together only because of “moratoriums” whose end-dates were contested and extended, for no one could come to an agreement.

The IPA then intervened, dispatching its president, Edward Joseph, on a visit on October 6, 1980, to attempt to clarify the situation and encourage the SPP to find a solution to the conflicts. Raymond Cahn, elected president of the society, decided on November 25 to create a joint society-institute committee charged with presenting, within four months, a proposal for global revision of the statutes of the society and the institute. This proposed merger was voted in by the SPP on June 23, 1981, but rejected the following week at the level of the institute, essentially by the college of the affiliated members. At the Thirty-second International Congress in Helsinki the following month, the IPA decided to nominate an external committee charged with investigating the SPP’s problems. It proposed a six-month moratorium, but nothing had been resolved as of June 18, 1982, when Adam Limentani, who had become president of the IPA, went to Paris. There had still been no resolution by March 1984, when conflicts between the offices of the SPP, under Michel Fain’s presidency, and the Institut de psychanalyse, headed by Claude Girard, nonetheless precipitated the end of the crisis.

In a letter dated May 21, 1984, Adam Limentani noted that no one wanted to succeed Michel Fain, and announced that the SPP had to be placed under oversight, and that the institute had to transfer to the society all of its training activities. Daniel Widlöcher was a member of the oversight committee. In October 1984, Augustin Jeanneau was elected president, and he was determined to bring to its conclusion this reform that had been dragging on for ten years. He nevertheless had to wait almost another year and a half before the SPP, on May 6, 1986, voted to accept the new proposal for a merger that he had elaborated with the active help of Michèle Perron-Borelli; an extraordinary session of the Institut de psychanalyse on June 3 in turn formally ratified it.

The merger at last took place, and the SPP reclaimed the ground that it had lost with the creation of the Institut de psychanalyse in 1953. The institute remained its “training organ,” but the autonomous organization that constituted it was dissolved. The price of this compromise was that the problems relating to training analyses were not taken into account in drawing up the statutes, but instead left to the initiative and responsibility of the institute’s Commission on Teaching—that is, the permanent members. The society, meanwhile, was henceforth managed by a general committee made up of all the members, represented by an administrative board of forty-five members elected by the college in a system of parity representation. The society put an end to the unsound, two-headed functioning that was also in violation of French laws on associations.

On December 2, 1986, André Green was elected president of the new bureau of the organization whose creation he had set in motion exactly twelve years earlier. Simone Decobert became the first director of the new institute and remained in this post until 1996, when she was replaced by Paul Israël.

Suddenly, everything calmed down, or almost. There was an influx of candidates for permanent membership, and the SPP, four hundred and fifty members strong, encouraged the formation of groups in the provinces that brought together former students and attracted new ones: the Groupe lyonnais, the oldest of these (1958), the Groupe toulousain (1980), and the Groupe de travail méditerranéen (1984) were followed by other groups in Bordeaux, Brittany, the Loire region, Normandy, Pas-de-Calais-Picardy in the north, Grenoble, and Savoy. The creation of the Journées occitanes de psychanalyse (Occitan Days of Psychoanalysis) in 1978 gave the signal for regional initiatives.

Certain personalities, such as Robert Barande, Conrad Stein, or Serge Viderman more or less distanced themselves from the society’s activities, but on the whole the members appeared to be relieved by the outcome and determined to show the outside world that all that these years of dispute had brought much that was ultimately constructive for the discipline. They had been schooled in the exercise of democracy, with its contradictions, but also with the possibility of the confrontation of contradictory opinions, without any new “autocrat” having taken the dominant ideological position, and without another

split occurring to bring a brutal resolution to the apparent incompatibilities.

Moreover, work in the field of psychoanalysis had never ceased, even though too much time and energy had been tied up in the endless statutory discussions. The Tuesday evening scientific meetings maintained their monthly schedule and the Saturday Encounters continued to be held twice each month, providing a proving ground for the next generation of analysts. The society’s colloquium, started by René Diatkine in 1964, took place regularly in Deauville every autumn, focusing on theoretical and clinical topics. In March 1998, responsibility for organizing the colloquium was entrusted to André Green, and it was named the René Diatkine Colloquium in honor of its founder. The Congresses of French-speaking Psychoanalysts, under the guidance of Augustin Jeanneau, who succeeded Pierre Luquet in 1989, and Pearl Lombard, and then, beginning in 1997, that of Gérard Bayle and Georges Pragier, held in alternating years in Paris and a neighboring region, continued to serve as a forum for annual presentation of reports as a way of taking stock of advances in psychoanalytic theory in France and worldwide. From 1989, Franco-Italian colloquia confirmed the need for meetings between neighboring societies. The precursors of a trend toward openness that would increase over time, the Rencontres psychanalytiques d’Aix-en-Provence (Aix-en-Provence Psychoanalytic Meetings), placed under the aegis of the society by Jacques Caïn and Alain de Mijolla, from 1982 to 1991 brought a member of the SPP together with a psychoanalytic personality from another group and a non-psychoanalyst specialist from the field of the chosen common theme, ranging from “Languages” to “The Body and History,” “Autobiography,” and “Music.” Christian David, Jean Guillaumin, André Green, René Diatkine, Francis Pasche, Joyce McDougall, Michel Fain, Jean Cournut, Michel Neyraut, Claude Le Guen, and Conrad Stein thus met with Piera Aulagnier, Jean-Bertrand Pontalis, Pierre Férida, Olivier Flournoy, Michel Artières, Marie Moscovici, and Michel Schneider, and compared their psychoanalytic point of view with the perspectives offered by non-psychoanalysts such as Maurice Olender, Edmond Jabès, Eugène Enriquez, Philippe Lejeune, Isabelle Stengers, Marcel Détienne, Yves Hersant, and André Boucourechliev.

Begun on a modest scale beginning in the 1960s, when it was handled by Louis Dujarrier and distribu-

ted in the form of galleys duplicated by Roneo ®, information for the membership became a major necessity that was concretized in the creation of a journal, the *Bulletin de la S.P.P.*, the first issue of which was published in 1982, introduced by Michel Fain. Jacqueline Schaeffer took over as head of the journal in 1985. The society's library, which had a wealth of holdings thanks to the bequest of Marie Bonaparte and the accumulation of other consignments and acquisitions over the years, was housed, under the direction of Roger Perron (who succeeded Gérard Bayle), in new quarters in the Rue Vauquelin in 1994; named the Bibliothèque Sigmund Freud, it became France's most comprehensive repository of psychoanalytic works. Its computerized catalogue was made available to researchers by means of the Internet under the leadership of Ruth Menahem, who was succeeded by Eva Weil. For several years the library published a bulletin of reviews of works, *Lectures*, headed by Perel Wilgocz. Meanwhile, the creation of a Department of Archives and History, decided on in January 1988, and headed by Alain de Mijolla, then by Alexandra Munier, and then, after 2002, by Nicolas Gougoulis, witnessed the constitution of an audiovisual archive devoted to some eminent members of the society. The Archives de France took responsibility for the cataloguing and archiving of all the administrative documents that had accumulated since the 1950s.

Relations with the government were marked by intense discussions around the 1982 proposal presented by Maurice Godelier to the minister of Research and Industry with the aim of creating a center for the development of psychoanalytic research. Supported at the SPP by Gérard Mendel and discussed at length, the proposal in the end did not lead anywhere, but the issue of the "status of psychoanalysis" regularly came up in government debates and at the instigation of certain people, such as Serge Leclaire in December 1989; however, this did not lead the SPP to abandon its reserve and go back on its refusal to sanction the official recognition under the label "psychoanalysts" certain, essentially Lacanian, groups whose training criteria it viewed as inadequate. Not that the SPP was excessively rigorous on this matter, as its frays with the IPA had continually shown. The SPP recognized three sessions per week as the minimum for a training analysis, instead of the four sessions required by the international organization. The society, under the leadership of Sacha Nacht, had been one of the first in the

world to totally exclude a candidate's analyst from discussions and decisions concerning his or her accreditation. As early as the 1950s the SPP had implemented "collective supervision," which was unknown in the other IPA member organizations, and, around 1965, the "trial assessment." In terms of relations with the government, after successfully fighting against the 1981 decision of the Ministry of Finance to subject non-physician psychoanalysts, and subsequently those who did not have a degree in psychology, to the value-added tax (VAT), the society's only official step was its 1997 request for recognition as a public service organization, a possibility that had been raised as early as 1967—at the time, there were rumors that Jacques Lacan had requested this—but that had been ruled out owing to the society's desire to remain independent of any control by the state. In the fall of 2003, the tumult occasioned by the threat of an "amendment" intended to regulate the practice of psychotherapy enabled the SPP to state its position clearly: "Psychoanalysis, which includes what is known as 'psychoanalytic psychotherapy,' is the purview only of psychoanalytic organizations accredited to guarantee the training and qualification of their members."

Thus, from 1987, under the presidency of André Green and his successors, the SPP practiced a policy of communication with the outside, a different image from the slightly outmoded one of a conservative "orthodoxy" that had been associated with the institute. Already, the Thursday lecture series, open to the public simply by registration, had made it possible to transmit the basics of Freudian theory and clinical practice to listeners from all walks of life. The two days for reflection organized on January 14–15, 1989, in the UNESCO building, on the theme of "Psychoanalysis: Questions for Tomorrow," under André Green's presidency, were a major success in this direction, mobilizing the media and making it possible to disseminate to some 950 registered listeners documents that clearly explained the goals and mode of operation of an organization whose previous desire to remain outside of the public realm had resulted in its being misunderstood and misjudged. Two additional days of meetings, organized by André Green and Alain Fine on November 23–24, 2002, created a forum for dialogue on the theme of "The Work of Psychoanalysis" between practitioners and the principal French psychoanalytic societies.

This was also a way of responding to the media attention garnered by the many groups and micro-



groups born of the dissolution of the *École freudienne de Paris*. Other colloquia open to the public were organized by Gilbert Diatkine in 1994, on the “Powers and Limits of Psychoanalysis,” and by Marilia Aisenstein in 1996, on “Ill-Being: Anxiety and Violence.” At the same time, internal colloquia were held, such as “The Drives,” organized by André Green in 1995; “The Object in Person,” organized by Paul Denis in 1996; and “Psychotherapeutic interpretation, psychoanalytic interpretation,” organized by Gilbert Diatkine in March 1997.

Among the institutions linked to the SPP that continued their work throughout these years, mention must be made of the Centre de consultations et de traitements psychanalytiques, which, from its creation in 1954, made psychoanalytic treatment available free of charge for the most economically disadvantaged. Under the leadership of Michel Cénac and René Diatkine, Jean Favreau and Robert Barande, Jean-Luc Donnet and Monique Cournut, and, from January 2000, Jean-Louis Baldacci, it also provided for the clinical training of several generations of psychoanalysts. It was renamed the Centre Jean-Favreau in December 1993.

The *Revue française de psychanalyse*, meanwhile, continued in its efforts to present the work of members of the SPP. The journal made no further changes in publisher after 1947, when it was taken on by the Presses Universitaires de France, and the successive managing and editorial teams, despite not-infrequent conflicts, first and foremost sought to ensure the regular publication of the congresses of the French-speaking psychoanalytic community and the work coming out of the various conferences, colloquia, and other scientific meetings. However, from 1988, under the direction of Claude Le Guen, assisted by Gérard Bayle and Jean Cornut, the journal’s autonomy in relation to the society, which had tried in vain to obtain the previous directorships, intensified, the latter having found a place for expression in its *Bulletin*, which, from 1991, also published texts from the congresses. The decision henceforth to produce thematic issues led to a clear-cut increase in the readership of the *Revue*, which was both older and the most widespread of the French psychoanalytic journals. That same year, 1988, Claude Le Guen, assisted by Gilbert Diatkine, created the Monographies de la *R.F.P.* (Monographs of the *R.F.P.*), a series in which each issue, focusing on a specific theoretical or practical point, was an assured publishing success. The series *Débats de psychanalyse* (Debates in Psychoanalysis), of which Jacqueline

Schaeffer was the assistant director, was created in 1995 with the aim of publishing the proceedings of colloquia and scientific meetings, which the *Bulletin* alone could no longer handle. In March 1996 Paul Denis took over the direction of the *Revue française de psychanalyse* and created the series *Psychanalystes d’aujourd’hui* (Psychoanalysts of today).

The Society’s membership in and faithfulness to the IPA were concretized—following the lead of Marie Bonaparte, vice president after the war and honorary president from 1957—by Sacha Nacht, vice president from 1957 to 1969, by André Green from 1975 to 1977, and, above all, by Serge Lebovici, vice president from 1967 to 1973, and up to that point the only Frenchman to have been elected president of the IPA, from 1973 to 1977, and then by Haydée Faimberg and Paul Israël, each of whom served in turn as vice president. The SPP, however, was never subservient to the IPA, as attested to by the numerous disagreements that marked the history of relations between the two institutions, from the criteria for training analysis to the creation of the Chamber of Delegates announced in 1993. The SPP also maintained links with the European Federation of Psychoanalysis, in which a number of its members played important roles, such as Alain Gibeault, who was president from 1995 to 1999 before being named secretary general of the IPA alongside Daniel Widlöcher.

Citing the names of members of the SPP throughout this article makes it unnecessary to say more about the organization’s scientific resonance and the place that the work of its members ensured within the psychoanalytic landscape in France and internationally. Whether in terms of readings of psychoanalytic texts, reflections on metapsychology, studies on the psychoanalytic process and situation, on psychoanalytic conceptions in the areas of psychopathology or therapeutics, child psychoanalysis, individual or group psychoanalytic psychotherapy, psychodrama, psychosomatics, research on the history of psychoanalysis, or the relationship between science and psychoanalysis, the number of institutional creations or original theoretical contributions by members of the SPP is considerable, as is the list of collections of reference works or journals that they head or in which they participate.

André Green’s successors to the presidency of the society, Michèle Perron-Borelli (elected in January 1989, she resigned in February 1990 after a dispute with the board of directors over policies regarding Serge Leclair’s proposed “ordinal authority”), Paul

Israël (1990–94), Gilbert Diatkine (1994–96), Marilia Aisenstein (1996–98), Jean Cournot (1998–2002), and Alain Fine (1998–2004) have pursued the policies of openness initiated by the 1986 reforms, in a spirit of rigor attested to by the creation in 1995 of a Commission on Deontology charged with elaborating and enforcing a code of ethics. A report by Paul Denis on behalf of the Socioprofessional Commission, supported by Michèle Perron-Borelli, petitioned beginning in 1989 to ask for recognition as a public service organization; in January 1996 a general assembly of the SPP voted in favor of requesting such recognition. A new modification of the statutes followed to make the necessary adaptations for this change in status, which was granted by a degree published in the *Journal officiel* of August 20, 1997.

With nearly 600 members extensively trained in psychoanalytic theory and practice (109 permanent members, 82 members, and 383 affiliated members), the SPP provides, for the diversity in thinking implicit in such a gathering, an open forum for discussion and developments that nevertheless remain within the strict framework of Freudian thought. Plans are under study for a federation-type organization that would bring together the psychoanalysts in France who would feel linked to such an entity, for the importance of regional groups has only grown over the years, making up for the lag that occurred from the 1960s to the 1980s, to the benefit of other psychoanalytic organizations, particularly those coming out of the *École freudienne de Paris*. The Institut de psychanalyse de Lyon's move to become autonomous in 1996, with Françoise Brette as its first director, is a testament to this. Doubtless one of the next tasks of the SPP will be to organize this mode of affiliation on a national scale, since there is such lively demand from those who identify with the currents of thought and the institutional building that have characterized, with the many vicissitudes that are synonymous with life and many democratic debates, its long historic pathway and the place it has been able to take and maintain for almost eighty years in the French psychoanalytic movement.

ALAIN DE MIJOLLA

### **Bibliography**

Mijolla, Alain de. (1992). France, 1893–1965, in *Psychoanalysis international: A guide to psychoanalysis throughout the*

*world*, volume 1: *Europe*. (p. 66–113) Stuttgart-Bad Cannstatt: Frommann-Holzboog, .

———. (1988). Psychoanalysis and psychoanalysts in France between 1939 and 1945. *International Forum of Psychoanalysis*, 12, 136–156.

———. (1988). Quelques aperçus sur le rôle de la princesse Marie Bonaparte dans la création de la Société psychanalytique de Paris. *Revue française de psychanalyse*, 52 (5), 1197–1214.

———. (1991). Les congrès des psychanalystes de langue française des pays romans: Quelques éléments d'histoire. *Revue française de psychanalyse*, 55 (1), 7–36.

———. (2001). Splits in the French Psychoanalytic movement between 1953 and 1964. In R. Steiner and J. Johns (Eds.), *Within Time and Beyond Time* (pp. 1–24). London: Karnac.

Perron, Roger. (1990). Médecins et non-médecins dans l'histoire de la Société psychanalytique de Paris. *Revue internationale d'histoire de la psychanalyse*, 3, 167–98.

---

## **SOCIOLOGY AND PSYCHOANALYSIS/ SOCIOPSYCHOANALYSIS**

Sociology is the methodological study of social facts, processes, and actions. Depending on the author, it is a general nomothetic science of society (Émile Durkheim), a science of the social forms resulting from the interaction among individuals (Georg Simmel), a discipline that strives to comprehend social activity (Max Weber), or “the living aspect, “the living aspect, the fleeting moment when society, or men, become sentimentally aware of themselves and of their relation to others” (Mauss M., 1923/1990, 80). Psychoanalysis is a method of investigating the individual psychic apparatus and a psychotherapeutic method that uses the transference that occurs during treatment as a powerful means of healing. Sociopsychanalyse (a term not yet fully accepted) is a discipline that aims to articulate the relationship between the psychic and the social. In this respect, sociopsychanalyse continues in the tradition of Freud's sociological and anthropological efforts.

The term “sociology” was created by Auguste Comte, who used it in volume 4 of his *Cours de philosophie positive* (1847). It replaced the term “social physiology,” put forward by Henri de Saint-Simon (1813). Yet it did not take on its modern meaning until Durkheim's *Rules of Sociological Method* (1895). The French terms “sociopsychanalyse,” “socioanalyse,” and

“sociothérapie” were used by different French authors after World War II (André Amar, Guy Palmade, Max Pagès, Jacques and Maria Van Bockstaele, Gérard Mendel, among others). It seems that the Englishman Elliott Jaques was the first to use the English term “socio-analysis,” in 1947, in his work of rehabilitating soldiers back from the war.

The desire to establish a link between psychoanalysis and sociology appears very early on in Freud’s work. The articles “Obsessive Actions and Religious Practices” (1907b) and “‘Civilized’ Sexual Morality and Modern Nervous Illness” (1908d) are evidence of this. In 1913 in “The Claims of Psychoanalysis to Scientific Interest,” Freud stressed the contributions that psychoanalysis could make to all the previously constituted psychological and social sciences, the unconscious often playing a role of primordial importance in all sorts of human behavior. In his later works, from *Totem and Taboo* (1912–1913a) to *Moses and Monotheism* (1939a), Freud analyzed the events that presided over the foundation and modification of social links, the advent of civilization, and the rise of its current discontents.

Many authors have followed in the path opened up by Freud in an effort to understand the evolution of civilization. Wilhelm Reich, the founder of “Freudo-Marxism,” analyzed the role of the family in the creation of authoritarian behaviors and the role of capitalist-patriarchal society in suppressing the instincts. Herbert Marcuse stressed the excessive suppression engendered by the capitalist system and the capacity of the most alienated classes to fight against the modern state and its tendency to make the individual into a “one-dimensional man.” By studying various types of societies and analyzing many different myths and legends, the anthropologist and psychoanalyst Géza Róheim succeeded in demonstrating that Freud’s fundamental hypotheses (the primitive horde, murder of the father, the Oedipus complex) are pertinent to all cultures, regardless of how different they might be.

Other researchers have taken a greater interest in the relations between psychoanalysis and politics and the phenomenon of power in modern societies. Theodor W. Adorno attempted to define the authoritarian personality, the source of all fascisms. Norman Brown tried to demonstrate the role of the life and death instincts in social functioning. Serge Moscovici studied crowds and the role of the leader, thus paying homage to the pioneering character of Freud’s *Totem*

and *Taboo* (1912–1913a) and *Group Psychology and the Analysis of the Ego* (1921c). Eugène Enriquez found in Freud’s work the elements necessary for his theory of the social link, and Cornelius Castoriadis used this theory to define the primary role of the imaginary in the institution of society. Pierre Legendre highlighted underdogs’ love for superiors, and Pierre Ansart focused on how political passions are managed.

Moreover, psychoanalysis has contributed to the creation of an original school of psychology and clinical sociology by analyzing the unconscious processes at work in groups, organizations, and institutions. First British authors (Wilfred R. Bion, Elliott Jaques), then French authors (Max Pagès, Gérard Mendel, Didier Anzieu, René Kaës, Jean-Claude Rouchy, André Lévy, and Eugène Enriquez), contributed new elements on the fantasies, projections, and identifications constantly at play in these groups, as well as on the organizational imaginary and on the processes of repression, suppression, and idealization at work in organizations. In South America, a school was formed to conduct a “social clinic.”

Undergoing particular development since 1990 have been “psycho-sociology,” the science of groups, organizations, and institutions (Kurt Lewin and the French authors mentioned above), and clinical sociology (Louis Wirth), particularly in Quebec and in France. In fact, clinical sociology was recognized as a branch of sociology by the International Sociological Association in 1993. It seeks to create a sociology that is close to lived experience and that makes the subject and the subject’s splitting and contradictions central elements in social construction.

Efforts to link sociology and psychoanalysis have yielded varied results. While some authors have defined original approaches, enriched analytic theory, and furthered the comprehension of social phenomena, others in France, intoxicated by the success of analysis, have indiscriminately applied psychoanalytic concepts to social reality and have succeeded only in bastardizing psychoanalysis (making it a management tool) and disfiguring social processes.

EUGÈNE ENRIQUEZ

See also: “Claims of Psychoanalysis to Scientific Interest”; Collective psychology; Criminology and psychoanalysis; Ego; *Group Psychology and the Analysis of the Ego*; Le Bon, Gustave; *Moses and Monotheism*; Politics and

psychoanalysis; Reich, Wilhelm; Rite and ritual; Taboo; *Totem and Taboo*.

### **Bibliography**

- Freud, Sigmund. (1907b). Obsessive actions and religious practices. *SE*, 9: 115–127.
- . (1908d). “Civilized” sexual morality and modern nervous illness. *SE*, 9: 177–204.
- . (1913j). The claims of psychoanalysis to scientific interest. *SE*, 13: 163–190.
- . (1912–1913a). Totem and taboo. *SE*, 13: 1–161.
- . (1921c). Group psychology and the analysis of the ego. *SE*, 18: 65–143.
- . (1930a [1929]). Civilization and its discontents. *SE*, 21: 57–145.
- . (1939a [1934–1938]). Moses and monotheism: three essays. *SE*, 23: 1–137.
- Kaës, René. (1993). *Le groupe et le sujet du groupe*. Paris: Dunod.
- Marcuse, Herbert. (1964). *One dimensional man*. Boston: Beacon Press.
- Mauss, Marcel. (1990). *The gift: The form and reason for exchange in archaic societies* (W. D. Halls, Trans.) New York: W.W. Norton. (Original work published 1923)
- Mendel, Gérard. (1968). *La révolte contre le père*. Paris: Payot.
- Róheim, Géza. (1950). *Psychoanalysis and anthropology*. New York: International Universities Press.

---

## **SOKOLNICKA-KUTNER, EUGÉNIE (1884–1934)**

Eugénie Sokolnicka-Kutner, the Polish psychoanalyst who introduced psychoanalysis to France, was born in Warsaw on June 14, 1884 and died in Paris on May 19, 1934.

Eugenia Kutner came from a Jewish bourgeois family that had demonstrated its political attachment to the Polish nation. Having been reared by a French governess, she naturally turned to France at the end of her secondary education with a view to enrolling in the Sorbonne to study biology and majoring in science. She also attended Pierre Janet’s lectures and established friendships in literary circles that she would rediscover fifteen years later.

She met M. Sokolnicki there and they got married when she returned to Poland. She devoted herself exclusively to family life until 1911 when she went to study at the Burghölzli asylum in Zurich, where she met Carl Gustav Jung. At the time of Jung’s break with Freud, she decided to go to Vienna and began her analysis with Freud; this lasted about one year and provoked a rather hostile counter-transference in Freud. She and Sokolnicki divorced at this time.

Also at this time she attended a few sessions of the Vienna Psychoanalytic Society (Nunberg H., Federn E., 1962–75) before settling in Munich on Freud’s advice. It may have been during this period that she analyzed Felix Boehm. The First World War forced her to return to Warsaw until the threat from the Germans and the Russians caused her to again flee, this time to Zurich in 1916. She became a member of the Zurich Psychoanalytic Society and was also elected to the Vienna Psychoanalytic Society on November 8, 1916.

Toward the end of 1917 she returned to Poland, and Freud wrote, in a letter to Sándor Ferenczi dated January 19, 1918 that “Sokolnick seems to be founding a psychoanalytic society in Warsaw.” For six weeks in 1919 she treated a little Jewish boy from Minsk who was suffering from an obsessional neurosis, the cure being classically centered round the transference and the interpretation of dreams, although a pedagogical attitude made its appearance, mainly with regard to sexuality (Ferenczi described it as an example of the “active technique”). It is, however, one of the first examples of a child analysis being conducted under conditions similar to those used for adults. She published the case the following year under the title: “Analysis of a Case of Infantile Obsessional Neurosis.”

At the start of 1920 she went to Budapest, and in January she began an analysis lasting about one year with Sándor Ferenczi who, sometimes as if in a kind of supervision, described its progression in his correspondence with Freud. She was not an easy patient, suffering from personality problems, mainly irritability, and describing Ferenczi as incapable compared to Freud, whom she nevertheless accused of putting an end to her analysis because she had no money as a result of her divorce. She also complained that Otto Rank had wounded her. These so-called paranoid characteristics were linked to depressive tendencies and accompanied by disturbing suicide threats. Alongside all of this, Ferenczi stressed her talent as a psychoanalyst and the quality of her interpretations.

In September 1920 she took part in the sixth International Congress at The Hague, presenting a paper on “Diagnosis and symptoms of neuroses in the light of psychoanalytic doctrines” and, in January 1921, expressed her intention of joining her brother in Paris. Ferenczi then asked Freud to recommend her to his Payot editor and his translator Samuel Jankélévitch, a request that Freud deferred granting until later, adding: “Besides, we *both* don’t like her, whereas you obviously have a weakness for this disagreeable person” (letter dated January 16, 1921). She again visited Freud between February and March and, upon finally receiving his approval, left for Paris.

Her relations were then in the literary milieu, particularly around the *Nouvelle Revue française*. There, as soon as she arrived in the fall of 1921, she found a public that was passionate about the “Freud sessions” she organized and which were attended by Jacques Rivière and André Gide. The latter is thought to have had a few analysis sessions with her and have depicted her in 1925 as “Doctoress Sophroniska” in *The Counterfeiters*.

During the winter of 1922–1923 she delivered several lectures at the *École des hautes études en sciences sociales*, meeting Georges Heuyer there through Paul Bourget. Heuyer, who ran the mental illness clinic of the Sainte-Anne hospital before the arrival of Henri Claude, invited her to attend the meetings and case presentations in his department. There she met young psychiatrists who, like René Laforgue for a few months or his friend Édouard Pichon for three years (1923–1926), were to go through the experience of training analysis with her. She soon either fled the hospital before Georges Dumas’s sarcasm, or was pushed out by Henri Claude who would have nothing to do with non-physician psychoanalysts. She failed to become the leader of a French psychoanalytic movement, abandoning that position to Laforgue and Marie Bonaparte, in spite of her support from Freud, who took her side rather than trust Laforgue, to whom he wrote on January 15, 1924: “We would have very much appreciated your working in cooperation with Mme Sokolnicka because we have known her for a very long time and we cannot help seeing her as our legitimate representative.”

She was appointed vice-president at the founding of the Paris Psychoanalytic Society in November 1926 and her teaching activity continued to increase con-

stantly. In June 1929 she presented a report to the fourth Conference of French-Speaking Psychoanalysts on “Some problems in psychoanalytic technique.” She analyzed Paulette Laforgue after her hysterectomy, Blanche Reverchon-Jouve, and Paul Schiff, but her clientele diminished over the years, leading her to practice shortened cures that barely earned her enough to live. Perhaps her turbulent sexual life was to blame, or the manifestations of the quick temper that Ferenczi described to Freud on February 11, 1921: “Actually she has suffered and is suffering not from a typical neurosis but from pathological sensitivity.”

It may be that from 1931 onward she progressively came under the influence of a state of depression. Having been announced for the opening of the Paris Psychoanalytic Institute in 1934 as speaking from May 2 to 23 on the “psychoanalysis of the character,” she died of what was probably a deliberate case of gas poisoning on May 19, 1934, less than a month from her fiftieth birthday.

ALAIN DE MIJOLLA

*See also:* Claude, Henri Charles Jules; Heuyer, Georges; Literature and psychoanalysis; Poland; Technique with children, psychoanalytic; Société psychanalytique de Paris et Institut de psychanalyse de Paris.

### Bibliography

- Duhamel, Pascale. (1988). Eugénie Sokolnicka (1884–1934): entre l’oublié et le tragique. Mémoire pour le Certificat d’études spéciales de psychiatrie. Bordeaux-II.
- Pichon, Édouard. (1934). Eugénie Sokolnicka. *Revue française de psychanalyse*, 9 (4), 559–588.
- Sokolnicka, Eugénie. (1920). Analysis of an obsessional neurosis in a child. *International Journal of Psycho-Analysis*, 3, 306–319.
- . (1929). Quelques problèmes de technique psychoanalytique. *Revue française de psychanalyse*, 3 (1), 1–91.

---

## SOMATIC COMPLIANCE

The notion of somatic compliance was introduced by Sigmund Freud within the framework of certain so-called somatic symptoms found exclusively in the hysteric, pointing toward what he calls “conversion phenomena.”

Freud uses this expression for the first time in the case of Dora (“Fragment of an Analysis of a Case of Hysteria” [1905e]): The hysterical symptom requires input from both sides, and “cannot occur without the presence of a certain degree of *somatic compliance* offered by some normal or pathological process in or connected with one of the bodily organs” (p. 40). It is this “compliance” at the somatic level which “may afford the unconscious mental processes with a physical outlet” (p. 41) and which, accordingly, becomes a determining factor in the choice of neurosis. Meanwhile, this somewhat enigmatic notion of somatic compliance helps explain the equally enigmatic leap from the mental to the somatic level. “Conversion” is posited as one of the outcomes of unconscious processes, providing a privileged medium for the symbolic expression of unconscious conflict and especially well able to signify the repressed. Conversion is thus part of the framework of symbolization, in contrast to the somatic symptom properly speaking. Freud provides examples of somatic compliance, and thus of the phenomenon of conversion, in the case of Dora. In the same context he mentions “secondary gain from illness” and “flight into illness.”

Aside from hysteria, somatic compliance in a more general sense raises the question of the expressive power of a given organ or body area that is in some sense hysterical or erogenized, as indeed of the whole body as a means of expression—as a vicissitude of the narcissistic cathexis of the body.

Can the notion be used, as in the conception of Jean-Paul Valabrega, to buttress a theory of psychosomatic phenomena as the outcome of a general process of conversion occurring outside the realm of hysteria, but clearly investing somatic symptoms with meaning? If so, the notion of compliance would take on another dimension altogether.

ALAIN FINE

*See also:* Psychosomatic.

### **Bibliography**

- Freud, Sigmund. (1905e [1901]). Fragment of an analysis of a case of hysteria. *SE*, 7: 7–122.
- Valabrega, Jean-Paul. (1974). Problèmes de théorie psychosomatique. In *Encyclopédie médico-chirurgicale* (Vol. *Psychiatrie*). Paris: EMC. (Original work published 1966)

## **“SOME PSYCHICAL CONSEQUENCES OF THE ANATOMICAL DISTINCTION BETWEEN THE SEXES”**

This paper, finished by Freud in 1925 and read by his daughter Anna at the International Psycho-Analytical Congress in Hamburg on September 3, first appeared in the *Internationale Zeitschrift für Psychoanalyse* in the same year.

Freud began by noting that he could no longer afford, as in his early days when he had no fellow researchers, to put off publication of new discoveries made on the basis of a mere handful of cases, even though they might not as yet have been confirmed. Then, starting out (as usual) from consideration of boys, Freud drew several new conclusions concerning girls. During the phallic phase, he argued, the boy remains attached to his mother and experiences his father as a rival whose place vis-à-vis his mother he wishes to usurp; at the same time, he would like to replace his mother as his father’s love object. The Oedipus complex is thus described as having two forms, active and passive—a duality consonant with the bisexual constitution of humans. When the boy first sees the girl’s genital area, he denies his perception that she has no penis (only later will the threat of castration arouse an emotional storm in him). In contrast, when the girl discovers the penis of the boy, “she has seen it and knows that she is without it and wants to have it” (1925j, p. 252). She falls victim to penis envy and to a masculinity complex. Consequences include a feeling of inferiority, jealousy (1919e), and a loosening of the girl’s tender relationship with her mother, whom she blames for her lack of a penis (1925j, p. 254).

For Freud, clitoral masturbation is masculine in character, and the mutilated aspect of the organ in question explains why women tolerate masturbation worse than men. The unfolding of femininity is based on a desire to eliminate clitoral sexuality. Under the sway of the Oedipus complex, the girl abandons her desire for a penis and replaces it by the desire for a child, and with this in mind takes her father as love object: “Whereas in boys the Oedipus complex is destroyed by the castration complex, in girls it is made possible and led up to by the castration complex” (1925j, p. 256). Indeed, the Oedipus complex never really disappears in women (1924d). This, according to Freud, accounts for characteristically feminine traits linked to a weaker and less perfectly

formed superego. In this connection, Freud refused to see the sexes as equal.

It should be noted that Freud's description of women as castrated beings who "refuse to accept the fact of being castrated" is hardly endorsed by all psychoanalysts.

COLETTE CHILAND

*See also:* Archaic; Bisexuality; Castration complex; Disavowal; Female sexuality; Feminism and psychoanalysis; Masculinity/femininity; Negative hallucination; Penis envy.

### Source Citation

Freud, Sigmund. (1925j). Some psychical consequences of the anatomical distinction between the sexes. *SE*, 19: 248–258.

### Bibliography

Freud, Sigmund. (1919e). "A child is being beaten": a contribution to the study of the origin of sexual perversions. *SE*, 17: 175–204.

———. (1923e). The infantile genital organization. *SE* 19: 141–145.

———. (1924d). The dissolution of the Oedipus complex. *SE* 19: 171–179.

## SOMNAMBULISM

Somnambulism (or sleepwalking) describes an apparently aimless nighttime walking in an unconscious state, accompanied by motor activity of varying degrees of complexity. The next day, the sleeper has no memory of the episode. Sleepwalking episodes, which occur during the first part of the night, last from a few seconds to around thirty minutes. They begin in the latency period and generally stop after puberty.

Owing to the amnesia that follows episodes of sleepwalking, no secondary revision can be made by the sleeper. This did not prevent Sigmund Freud from taking an interest in the phenomenon. In 1907 he spoke about it to the Vienna Psychoanalytic Society (Nunberg and Federn): He believed that sleepwalking was related to the fulfillment of sexual wishes and was thus surprised that there could be mobility without

interruption of the dream life. Finally, at that time, he suggested that the essence of this phenomenon was the desire to go to sleep where the individual had slept in childhood.

Ten years later, he again speculated about somnambulism in the article "A Metapsychological Supplement to the Theory of Dreams" (1916–17 [1915]). In this essay, where he proposed to clarify and expand his hypothetical ideas on dreams, the dream is a fragile equilibrium that is only partially successful: first, because the repressed unconscious impulses of the unconscious system, which do not obey the wishes of the ego and maintain their counter-cathexis, mean that "some amount of the expenditure on repression (anticathexis) would have to be maintained throughout the night, in order to meet the instinctual danger" (p. 225); and second, because certain preconscious daytime thoughts can be resistant, and these, too, retain a part of their cathexis. It is thus apparent how unconscious impulses and day residues can come together and result in a conflict.

Freud then wondered about the outcome of this wishful impulse, which represents an unconscious instinctual demand and which becomes a dream wish in the preconscious. Further, he envisioned the case in which this unconscious impulse could be expressed as mobility during sleep. This would be what is observed in somnambulism, though what actually makes it possible remains unknown.

More recently, based on data from electrophysiological sleep studies showing that sleepwalking episodes occur in the early phases of sleep (phases III and IV), the psychoanalyst Didier Houzel has leaned in the direction of the Freud's hypotheses, positing that the slow sleep phase, by interfering with the phase of paradoxical sleep that follows and interrupts the latter, prevents the possibility of dream work. Somnambulism thus results from a blocking of the possibilities of mentalization and a diversion of the instinctual energy onto paths of motor discharge. Houzel's viewpoint posits equivalences between night terrors, sleepwalking, and nocturnal enuresis, all of which have the same relationship to paradoxical sleep.

PHILIPPE METELLO

*See also:* Animal magnetism; Hypnosis; Janet, Pierre; Trance.

### Bibliography

- Freud, Sigmund. (1916–17f [1915]). A metapsychological supplement to the theory of dreams. *SE*, 14: 217–235.
- Houzel, Didier. (1980). Rêve et psychopathologie de l'enfant. *Neuropsychiatrie de l'enfance et de l'adolescence*, 28, 155–164.
- Nunberg, Hermann, and Federn, Ernst. (1962–1975). *Minutes of the Vienna Psychoanalytic Society*. New York: International Universities Press.

## SPAIN

In February and March 1893, one month after its appearance in the Viennese journal *Neurologisches Zentralblatt*, two Spanish journals, the *Revista de ciencias médicas* in Barcelona and the *Gaceta médica* in Granada, published *On the Psychical Mechanism of Hysterical Phenomena* by Josef Breuer and Sigmund Freud (1893a). It was, in the words of James Strachey, “the very first publication in the world of a translation of a psychological work by Freud.”

In 1911 José Ortega y Gasset, the well-known intellectual, published a long article titled “Psicoanálisis, ciencia problemática” (Psychoanalysis, a problematic science), in which he recognized the importance of a great number of Freud’s contributions. This article provoked the publication of Freud’s works in Spanish. At Ortega’s suggestion, the publisher Ruiz Castillo acquired the rights to publish all existing and future works by Freud and commissioned López Ballesteros to translate them. The publication of the first translation in the world of Freud’s complete works in seventeen volumes appeared over ten years (1922–1932).

The most eminent psychiatrists of the time published various works in which they analyzed Freud’s work and assessed the value of his contributions, but they also criticized what they considered “the omnipotent unconscious sexuality in all psychical phenomena” and the subjectivity of the therapeutic method. Psychoanalytic ideas exercised a considerable influence on judges, teachers, and thinkers. Writers and artists also felt attracted by Freud’s discoveries. A group of intellectuals invited Freud to Spain to give conferences, but his illness prevented him from realizing this project. Sándor Ferenczi nevertheless went to Spain in October 1928 and conducted the communication program Learning

Psychoanalysis and Psychoanalytic Transformation of the Character.

The discourse on psychoanalysis, already present in Spanish psychiatry, prompted two psychiatrists, Ramon Sarró and Angel Garma, to acquire psychoanalytic training. Garma trained at the Vienna Psychoanalytic Institute. He returned to Madrid in November 1931 and left Spain for good in 1936. For the five years between 1931 and 1936, motivated by the desire to create a psychoanalytic movement in Spain, he worked intensely to promote the discipline. The Spanish Civil War broke out in July 1936 and put an end to his hopes. He then emigrated to Argentina, where he participated in the creation of the Asociación psicoanalítica argentina (Argentine Psychoanalytic Association).

The Civil War (1936–1939) and the years of dictatorship imposed silence on many cultural and scientific sectors, particularly psychoanalysis. It was not until the end of the 1940s that two small groups of psychiatrists and intellectuals, one in Madrid and the other in Barcelona, took steps to train as psychoanalysts and to introduce psychoanalysis to Spain. In 1949 the Madrid psychiatrist R. del Portillo turned to the Deutsche psychoanalytische Gesellschaft (German Psychoanalytic Society) for training. He was analyzed by M. Steimback, whom he invited to Madrid to act as a training analyst. Steimback accepted and, until 1954, the year of his death, participated in training such analysts as Drs. R. del Portillo, Ma Teresa Ruiz, Carolina Zamora, J. Pertejo, and Julio Corominas.

During this same period Drs. Bofill, Folch, and Nuria Abelló from Barcelona turned to the Swiss Psychoanalytical Society for training. There they came into contact with Drs. Rallo from Madrid and F. Alvin from Lisbon. Drs. Pertejo, Zamora, and Corominas organized the Grupo Luso-Español de psicoanálisis (Portuguese-Spanish Group for Psychoanalysis), which, sponsored by the Swiss and Paris societies, was recognized by the International Psychoanalytical Association (IPA) in 1957. In 1958 R. del Portillo and Ma Teresa Ruiz joined the group. During the International Congress in 1959 the International Psychoanalytical Association admitted the group as a member. Following the break with the Portuguese group in 1966, the Sociedad Luso-Español de psicoanálisis (Portuguese-Spanish Society for Psychoanalysis) became the Sociedad Española de psicoanálisis (Spanish Psychoanalytical Society).



In 1973 psychoanalysts practicing in Madrid decided to form an independent group, and in 1979 the International Psychoanalytical Association recognized the Asociación de psicoanálisis de Madrid (Madrid Psychoanalytical Association) at the thirty-first congress. From then on the two IPA-affiliated societies together contributed to the development of psychoanalysis in Spain.

The scientific activity of the two societies proved to be intense and prolific throughout the years. Publications by Drs. León Grinberg, Folch, Bofill, Coderch, Torres de Bea, Spilka, Cruz Roche, Manuel Pérez Sánchez, Utrilla, Paz, Olmos, Loren, Guimón, congresses, symposia, schools, conferences; the publication of the journals *Revista catalana de psicoanálisis* and the *Revista de psicoanálisis de Madrid*—all bear witness to ongoing reflections on psychoanalytic theory and clinical practice. In these and other ways the two societies were active in both the medical and academic spheres, thus contributing to the dissemination of psychoanalytic thought.

In 1975 Oscar Masotta, an Argentinean philosopher and member of the Freudian School of Paris, introduced Jacques Lacan's ideas in Spain. In 1977 the library *Biblioteca Freudiana* was created in Barcelona, thus embodying the first institutional form of Lacan's ideas in the country.

After Masotta's death (1979), the dissolution of the Freudian school of psychoanalysis (1980), and the death of Lacan himself (1981), the Lacanian groups broke up and dispersed. In 1990, a group of eminent personalities, among them Jacques-Alain Miller, Eric Laurent, and Colette Soler, founded the European School of Psychoanalysis and the first section of the branch school in Barcelona. Later in the 1990s, different sections have come together in the European School of Psychoanalysis—Spain. Other Lacanian groups also exist and are directly linked to various French groups.

One hundred years after the first publication in Spain of a work by Freud, a great many psychoanalytic ideas have taken hold in psychiatry, medicine, psychology, teaching, and ethics, and many psychoanalysts are actively working to relieve psychic pain and contribute to a better knowledge of human development, both normal and pathological.

MARÍA LUISA MUÑOZ

### **Bibliography**

- Bermejo, Frijole V. (1993). La institucionalización del psicoanálisis en España en el marco de la A.P.I. Doctoral thesis, faculty of psychology, University of Valencia.
- Caries, Egea. (1983). Introducción al psicoanálisis en España, 1893–1922. Doctoral thesis, University of Murcia.
- Muñoz, María Luisa. (1989, May–November). Contribución a la historia del movimiento psicoanalítico en España. *Revista de psicoanálisis*. Madrid.
- Muñoz Gonzalez, J. (1987). Evolución del psicoanálisis en España (1923–1936). Doctoral thesis, University of Murcia.
- Pérez Sánchez, Manuel. (1984). Inicios del movimiento psicoanalítico. *Revista catalana de psicoanálisis*, 1, 1.

---

### **SPECIFIC ACTION**

The purpose of specific action is to permit the release of tension in ways comparable with the instinctual aim. This term appeared in Freud's earliest writings, but he rarely used it afterwards.

The term “specific reaction” (*spezifische Reaktion*) was used by Freud in “Draft E” of his correspondence with Wilhelm Fliess, which dates probably to June 1894, and which he entitled “How Anxiety Originates” (in 1950a). He sketched an answer to this question from the point of view of an energetics of somatic-mental functioning, an approach that went on to play a major role in the development of his thought: anxiety resulted from an accumulation of tension (biological tension, in the sense that need was involved; but also mental tension, for it implied a wish in search of an object), when there was no way for this tension to be released. Tension could be released in two ways: in the form of violent cries, emotional outbursts, destructiveness, and so forth; or in a way adequate to the need—as for example, the ingestion of food for a baby, or engaging in coitus for an adult. Such adequate kinds of releases are what Freud called “specific reactions.” Freud developed these views in other writings of the same period (1894a [1895]), particularly in the “Project for a Scientific Psychology” (1950c [1895]).

The notion of “specific action” is sometimes deemed obsolete, or tainted by a naïve behaviorism. In fact, as early as 1894, Freud very plainly stressed the need to distinguish between the *biological* tension of need and the properly *psychic* level, where specific

action presupposes “preparations,” a whole “psychical working-through,” in the framework of the conflictual dynamic specific to the subject (Perron-Borelli). Much later, when Freud reframed his conception of anxiety, he added a “signal of anxiety”—a testimony to, and outcome of those working-through processes—to his earlier “automatic anxiety,” generated by the accumulation of tension.

ROGER PERRON

*See also:* Act/action; Anxiety.

### **Bibliography**

- Freud, Sigmund. (1894a). The neuro-psychoses of defence. *SE*, 3: 41–61.
- . (1895b). On the grounds for detaching a particular syndrome from neurasthenia under the description “anxiety neurosis.” *SE*, 3: 85–115.
- . (1926d [1925]). Inhibitions, symptoms and anxiety. *SE*, 20: 75–172.
- . (1950a [1887–1902]). Extracts from the Fliess papers. *SE*, 1: 173–280.
- . (1950c [1895]). Project for a scientific psychology. *SE*, 1: 281–387.
- Perron-Borelli, Michèle. (1997). *Dynamique du fantasme*. Paris: Presses Universitaires de France.

## **SPIELREIN, SABINA (1885–C. 1941)**

Sabina Spielrein, a Russian psychoanalyst, was born in 1885 in Rostov, and died in the city of her birth, in the Soviet Union, in 1941 or 1942, during World War II.

Born into a wealthy Jewish middle-class family, Sabina at age nineteen was taken to Zurich to be treated for severe hysteria. She was hospitalized at Burghölzli, the famous psychiatric university hospital run by Eugen Bleuler. There Carl G. Jung became her physician and succeeded in alleviating most of her symptoms. Within a year, by 1905, she was able to begin medical studies. She continued an analysis with Jung that he described as “Freudian” and that offered him an opportunity to initiate a relationship with Freud, from 1907.

The therapeutic relationship between Jung and Spielrein evolved into a personal relationship, probably a brief affair, after which Jung appears to have distanced himself from her and then called for Freud’s

help. The two men, who by then had been friends for two years, discussed the relationship in their correspondence, and at Jung’s request Freud wrote to Spielrein’s mother. In spite of what the two men thought, however, Freud’s intervention did not end Sabina’s passion for Jung, a passion documented in her diaries. Nonetheless, in 1911 she finished her studies in psychiatry under Jung’s direction with the thesis “The Psychological Content of a Case of Schizophrenia.” As Freud and Jung moved toward the rupture of their friendship and collaboration, Spielrein went to Vienna, where, in 1911, she presented her paper “Destruction as the Cause of Becoming” (1995), which received a mixed reception in the context of much anti-Jung sentiment.

After the break between Freud and Jung, in which she could not clearly decide which side to take, Spielrein’s life and career becomes more difficult to follow. In 1912 she married a Russian physician, Paul Scheffel, with whom she had a daughter in 1913; he returned to Russia in 1915. Spielrein could not settle down, moving successively to Zurich, Munich, Lausanne, and Geneva. She worked as an analyst but appears to have been uncertain whether her real calling was to psychoanalysis, art history, or music. A second daughter was born in 1926.

By 1923, with Freud’s encouragement, Spielrein had returned to Soviet Russia. She was admitted to the new Moscow Psychoanalytic Institute and taught psychoanalysis until it was prohibited in 1927. After returning to her birthplace, Rostov, during World War II, Spielrein was murdered by the Nazis, together with all the Jewish inhabitants of the city, in 1941 or 1942.

Spielrein published about thirty articles, the best known being her 1995 paper, which develops original ideas on female sexuality and is sometimes said to adumbrate Freud’s concept of the death instinct. It is unfortunate that a love affair and the troubled relationship between Freud and Jung played a role in her early disappearance from the intellectual ferment of psychoanalysis.

In spite of more shadow than light, her story retains an indisputable fascination. A series of fortuitous discoveries rescued Spielrein from oblivion. In 1977 a carton was discovered containing her diary and some of the letters she exchanged with Freud and Jung. A second cache, then a third, were recovered. These documents revealed the details of the long-suppressed

secret—an analysand seduced and abandoned by her analyst—which would have embarrassed Jung first and foremost, but also Freud, who had helped minimize the affair.

An intriguing and original figure in the early years of psychoanalysis, Spielrein subsequently became the object of considerable attention and the subject of several books.

NICOLLE KRESS-ROSEN

*See also:* Abstinence/rule of abstinence; Ethics; Jung, Carl Gustav; Death instinct (Thanatos); Russia/USSR; Société psychanalytique de Genève; Switzerland (German-speaking); Transference love.

### **Bibliography**

Carotenuto, Aldo, and Trombetta, Carlo. (1982). *A secret symmetry: Sabina Spielrein between Jung and Freud* (Arno Pomerans, John Shepley, and Krishna Winston, Trans.). New York: Pantheon Books. (Original work published 1977)

Kerr, John. (1993). *A most dangerous method: The story of Jung, Freud, and Sabina Spielrein*. New York: Alfred A. Knopf.

Kress-Rosen, Nicolle. (1993). *Trois figures de la passion*. Paris: Arcanes.

Spielrein, Sabina. (1995). Destruction as a cause of coming into being (S. K. Witt, Trans.). *Psychoanalysis and Contemporary Thought*, 18, 85–118. (Original work published 1911)

## **SPINOZA AND PSYCHOANALYSIS**

In the history of psychoanalysis, several philosophers became subjects of a privileged confrontation with Freud. One such philosopher was Baruch Spinoza (1632–1677). From the 1920s intellectuals noted correspondences between Freudian thought and Spinoza's philosophy (Smith, 1924; Alexander, 1927). This discussion continues to more recent times (Bodei, 1991; Ogilvie, 1993).

Freud himself rarely spoke of Spinoza. Although he referred to Spinoza in *Leonardo da Vinci and a Memory of his Childhood* (1910c), he did not explicitly mention Spinoza anywhere else. In the work of Jacques Lacan, Spinoza is often present in the background and occasionally cited. For instance, proposition 57 of part 3 of Spinoza's *Ethics* appears as an epigraph to Lacan's medical dissertation (1932).

Authors who have tried to situate Spinoza vis-à-vis psychoanalysis have pondered several different kinds of questions. W. Aron (1977) asked about the overall influence of Spinoza on Freud's thought. C. Rathbun (1934) noted that the libido, a fundamental concept of psychoanalysis, is adumbrated in Spinoza's concept of *conatus*, an inborn drive that leads to striving and persisting. On Walter Bernard's reading (1946), it is perhaps closer to eros or desire. But what, according to these authors, were Spinoza's therapeutic principles? These works today appear dated, indicative as much of the intellectual state of psychoanalysis, particularly in Anglo-Saxon countries, as of a poorly informed reading of Spinoza. Some authors, such as Abraham Kaplan (1977) recall that Spinoza's philosophy was not a proto-psychoanalytic science, but a very knowledgeable metaphysics. Francis Pasche (1981) discusses the idea of "practical psychoanalysis." Gilles Deleuze's work on Spinoza, *Expression in Philosophy* (1992), has opened the way toward a confrontation between Spinozistic and psychoanalytic ethics. Finally, several psychoanalytic authors (Bertrand, 1984; Ogilvie, 1993; Burbage and Chouchan, 1993) have discovered unconscious implications in Spinoza's philosophy.

MICHÈLE BERTRAND

*See also:* Althusser, Louis; Breuer, Josef; Determinism; Doubt; German romanticism and psychoanalysis; Goethe and psychoanalysis; Kantianism and psychoanalysis; Oceanic feeling; Philosophy and psychoanalysis; Pleasure in thinking; Rolland, Romain Edme Paul-Émile.

### **Bibliography**

Alexander, Bernhard. (1927). Spinoza und Psychoanalyse. *Chronicum Spinosanum*, 5, 96–103.

Bernard, Walter. (1946). Freud and Spinoza. *Psychiatry*, 5, 99–108.

Bertrand, Michèle. (1984). *Spinoza et l'imaginaire*. Paris: Presses Universitaires de France.

Bodei, Remo. (1991). *Geometrica delle passioni*. Rome: Feltrinelli.

Burbage, Frank, and Chouchan, Nathalie. (1993). Freud et Spinoza: la question de la transformation et le devenir actif du sujet. In Olivier Bloch (Ed.), *Spinoza au XXe siècle* (pp. 525–545). Paris: Presses Universitaires de France.

Deleuze, Gilles. (1992). *Expression in philosophy: Spinoza*. Cambridge, MA: Zone Books.

- Freud, Sigmund. (1910c). Leonardo da Vinci and a memory of his childhood. *SE*, 11: 57–137.
- Kaplan, Abraham. (1977). Spinoza and Freud. *Journal of the American Academy of Psychoanalysis*, 5, 299–326.
- Lacan, Jacques. (1932). De la psychose paranoïaque dans ses rapports avec la personnalité. Paris: Le François.
- Ogilvie, Bertrand. (1993). Spinoza dans la psychanalyse. In Olivier Bloch (Ed.), *Spinoza au XXe siècle* (pp. 549–571). Paris: Presses Universitaires de France.
- Pasche, Francis. (1981). Métaphysique et inconscient. *Revue Française de Psychanalyse*, 45 (1), 9–30.
- Rathbun, C. (1934). On certain similarities between Spinoza and psychoanalysis. *Psychoanalytic Review*, 21, 1, 1–14.
- Smith, Maurice Hamblin. (1924). An interesting dream. *International Journal of Psycho-Analysis*, 5, 4, 468–446.
- Spinoza, Benedictus de. (2000). *Ethics* (G. H. R. Parkinson, Trans.). New York: Oxford University Press.

## SPITZ, RENÉ ARPAD (1887–1974)

Hungarian psychiatrist and psychoanalyst René Arpad Spitz was born in Vienna, Austria, on January 29, 1887, and died in Denver, Colorado, on September 14, 1974.

From a wealthy Jewish family background, Spitz spent most of his childhood in Hungary. While studying medicine in Budapest—he became a physician in 1910—he discovered the works of Freud. During the First World War, he served in the army as a military physician. Encouraged by Sándor Ferenczi, he became one of the first to undergo a training analysis with Freud himself. Between 1924 and 1928, he participated in the Vienna Psychoanalytic Society and, subsequently, worked in Berlin, where he became member of the German Psychoanalytic Society (DPG).

Between 1932 and 1938 Spitz lived in Paris, where he taught psychoanalysis and child development at the elite *École Normale Supérieure*, and he frequently attended conferences of the Paris Psychoanalytic Society. In 1939 he emigrated to the United States and found work as a psychiatrist at Mount Sinai Hospital in New York (1940–1943). He served as a visiting professor at several universities before settling at the University of Colorado, where he conducted much of his research on infant development.

He served as president of the Denver Psychoanalytic Society (1962–63).

At the end of World War II, Spitz (1945, 1946) published his influential research with infants and young children in various settings, including a founding home and a penal nursery. Serious developmental pathologies, as he documented with careful research, arose in infants who, though adequately nourished, were deprived of maternal care and emotional sustenance. Through direct observation he developed the diagnoses of “hospitalism” and “anacletic depression,” two pathologies that led him to further study mental and emotional development from birth to two years of age.

Spitz is best known for his books on the infant and the mother-infant dyad, including *No and Yes: On the Genesis of Human Communication* (1957); *A Genetic Field Theory of Ego Formation* (1959); and *The First Year of Life* (1965). According to Spitz, infants pass through three stages corresponding to stepwise developments in object relations: (1) the objectless stage (three first months of life), characterized by “non-differentiation” between baby and its mother; (2) the stage of “the precursor of the object” (from three to eight months) in which the smiling response indicates the beginning of object relations; and (3) the stage of the libidinal object (from eighth to fifteenth month), by which time the mother is recognized as a real partner and the infant can distinguish her face from strangers’ faces. From the fifteenth month, the child enters into semantic communication with gesture and the use of “no,” indicating the emergence of the autonomous ego.

Spitz was the first of a small number of distinguished psychoanalysts to actively pursue research in child development by employing methods commonly used in experimental psychology; his use of films was particularly influential. In contrast to behavioral psychologists, however, Spitz believed that deep psychic process, while not directly observable, may be identified by surface “indicators” such as the smile. These reveal “the organizers of the psyche” that serve as evidence of the child’s maturation.

KATHLEEN KELLEY-LAINÉ

*See also:* Abandonment; Allergic object relationship; Congress of French-speaking psychoanalysts; Defense; Depravation; Ethology and psychoanalysis; Fear; France;

Hungarian school; Infant observation (therapeutic); Infant development; International Federation of Psychoanalytic Societies; Masturbation; Maturation; Mothering; Oral stage; Phobias in children; Phobic neurosis; Primary identification; Stranger, fear of; Sucking/thumbsucking; Switzerland (French-speaking); Symbiosis/symbiotic relation.

### **Bibliography**

Emde, Robert N. (Ed.). (1984). *Rene Spitz: Dialogues from infancy*. Madison, CT: International Universities Press.

Spitz, René. (1945). Hospitalism: An inquiry into the genesis of psychiatric conditions in early childhood. *Psychoanalytic Study of the Child*, 1, 53–74.

———. (1946). Anaclitic depression. *Psychoanalytic Study of the Child*, 2, 313–342.

———. (1957). *No and yes: On the genesis of human communication*. New York: International Universities Press.

———. (1959). *A genetic field theory of ego formation*. New York: International Universities Press.

———. (1965). *The first year of life*. New York: International Universities Press.

———. (1958). On the genesis of superego components. *Psychoanalytic Study of the Child*, 13, 375–404.

---

## **SPLIT OBJECT**

The concept of the splitting of the object was elaborated by Melanie Klein. This is a defense mechanism deployed by the ego against anxieties concerning the destructiveness of the death drive, and which is directed at maintaining the separation between a good object and a bad object to safeguard the security and integrity of the ego.

The object that is split in this way is the internal object; Klein developed this concept of internal object on the basis of the concept of introjection. In fact, according to Freud, the ego introjects external objects that are sources of pleasure, and expels outside of itself that which causes unpleasure. For Melanie Klein, splitting, introjection, and projection constitute the first defense mechanisms. In his “phantasies,” the child introjects parts of his parents’ bodies (the breast, the penis, and so on), and the parents are split into gratifying good objects and frustrating bad objects.

The infant’s first relationship is a relationship to part-objects, principally to the mother’s breast, which is split into the ideal breast and the persecuting breast. In this relationship, the ego projects the death drive outwards and introjects an ideal object that is the product of the projection of the life drive. Historically speaking, Melanie Klein described the depressive position first, but it was the elaboration of the concept of the paranoid-schizoid position that then enabled her to study the mechanism of projective identification, as the result of primitive projections. Projective identification consists in the identification of the object with the part of the self that has been projected, and it concerns both the good and the bad parts of the self and the object. The paranoid-schizoid position, which is characterized by the fragmentation of the ego and the splitting of the object, is followed by the depressive position, in which the ego is integrated but is in the grip of the conflict between opposed drives; repression then gradually takes over from splitting, and projective anxiety gives way to guilt. In the paranoid-schizoid position, splitting therefore relates to part-objects, whereas in the ensuing depressive position it relates to a total object.

The interest in the internal object and its splitting has led Kleinian analysts to develop an entire conceptual apparatus concerning the genesis, evolution, and position of the object in the psychic apparatus and in the dynamics of the object relationship. Also deserving mention here are Wilfred Bion’s beta-elements and alpha-elements and “K” and “O,” Frances Tustin’s sensation-objects and Donald Winnicott’s transitional object, as well as the role of dimensionality in Donald Meltzer’s work.

In clinical practice, these concepts provide a better understanding of the way in which the line of the splitting protects and maintains the idealized object, by separating it from the frustrating object that bears the hallmark of castration (particularly in perverse, depressive, or obsessional neurotic structures).

The concept of the splitting of the object, based on the concept of the splitting of the ego introduced by Freud, has made it possible to focus attention on the importance of the internal object and of the phantasy, and has opened up some productive perspectives concerning intersubjectivity.

PANOS ALOUPIS

*See also:* Object; Object, change of/choice of; Splitting; Splitting of the object.

### **Bibliography**

Freud, Sigmund. (1915c). Instincts and their vicissitudes. *SE*, 14: 109–140.

Klein, Melanie. (1948). *Contributions to psychoanalysis*. London, Hogarth, 1967.

———. (1952). The mutual influences in the development of ego and id. *Psychoanalytic Study of the Child*, 7, 51–53.

### **Further Reading**

Bass, Alan. (2001). *Difference and disavowal*. Palo Alto: Stanford University Press.

Grotstein, James. (1981). *Splitting and projective identification*. New York: Aronson.

---

## **SPLITS IN PSYCHOANALYSIS**

Since its beginning, the psychoanalytic movement has been plagued by conflicts and has given rise not only to numerous splinter movements, but also to adversarial sub-groups and internal divisions within its larger institutions. Some see this as an indication of the psychoanalytic movement's tendency towards dogmatic organizations that practice exclusion and "excommunication." But others see signs of what they call "heteroglossia," noting that with conflict, propositions that were once judged to be inconsistent with the general theory of psychoanalysis are later reincorporated into it.

The breakup of Freud's friendship with Wilhelm Fliess could be called, albeit a bit arbitrarily, the first psychoanalytic "split." The way they split seems almost paradigmatic: two passionate researchers who seemed similar were able to collaborate in spite of profound contradictions between them that remained hidden until the moment one of them began to assert himself.

The 1912 break between Freud and Alfred Adler could be described in just the same way, and likewise that of Freud and Carl Jung in 1913. Neither of the two came to Freud empty-handed. They each had their own theoretical ideas and their own body of research. And their encounters with Freud were for a time more like those between like-minded individuals. They were not waiting for any kind of illumination, which they believed they already possessed, but rather supplement-

tal clarifications, or better still, Freud's approval. Both followed theoretical tendencies that diverged from Freud's own ideas and personality and that indicated orientations characteristic of their time: Adler emphasized social factors, under the influence of the Marxist movement that unfolded for most of the twentieth century; Jung was preoccupied with mysticism and the esoteric tradition from which Freud, in spite of his curiosity, kept a distance in his theorizing, if not in private life. Each of them founded parallel movements that refused to take any advantage of their connections to psychoanalysis even by virtue of their names: Adler's "individual psychology" and Jung's "analytical psychology." Wilhelm Stekel, who left the psychoanalytic movement after Adler in 1912, remained a marginal figure and only had a few disciples who followed him personally without constituting a group.

The first true psychoanalytic split was that of Otto Rank in the aftermath of the publication of his book *The Trauma of Birth* in 1924. Rank was educated with Freud's help and even somewhat under Freud's wing, and he was a crucial player in the conception and the organization of the psychoanalytic movement. On the basis of Freudian premises, and by claiming to be their true inheritor, Rank separated himself from the very person to whom he owed his entire career. In contrast to others who moved up the Freudian ranks for a time and then took a divergent path only to disappear forever after, Rank did not remain alone, and only his early death prevented him from developing a school with successors to carry on his ideas. His ideas on trauma, the primal relation to the mother, and the shortening of the duration of the treatment are some of the themes that later emerged to take an increasingly important place in contemporary psychoanalysis. Sándor Ferenczi's influence in psychoanalysis followed a similar trajectory, and he only narrowly avoided a break with Freud over the experimental techniques of his late career, as detailed in his article on the "Confusion of Tongues" (1932). His death prevented a break with Freud, which would have been one of the last to have a theoretical cause. The same can be said of Wilhelm Reich, who was thrown out of the psychoanalytic movement in 1934, though his political activism was a precursor of the Freudian-Marxist movements that would appear some decades later.

Problems of training increasingly came to overtake theoretical disputes as the primary motive for splits. This shift was signaled in 1926 by the trial of Theodor

Reik for quackery, by Freud's commentary on the case in *The Question of Lay Analysis*, and by the discussion that ensued within the International Psychoanalytic Association in 1927. Training was confirmed as the new topic of debate by the creation of the Swiss Medical Society for Psychoanalysis in Zurich in 1928. The new society excluded non-physicians, a measure aimed specifically at Oskar Pfister. The debate intensified when, in 1938, the American Psychoanalytic Association's refusal to admit non-physicians to their membership led to the brink of a split with the International Psychoanalytic Association (I.P.A.). But as Ernest Jones said in all seriousness, "the advent of the Second World War altered the whole situation . . . and the Americans . . . cordially cooperated with [the I.P.A.]" (Jones, Vol. 3, p. 300). But it was actually the death of Freud in September 1939, along with the disruptions that accompanied the exodus of Jewish analysts from Europe, that would radically alter relations among analysts (Mijolla). This led to the codification of the qualifications for the status of "psychoanalyst," which Freud had held the supreme right to confer while he lived.

One of the last great theoretical debates was the controversy between the partisans of Anna Freud and those of Melanie Klein from 1941 to 1945. The debate almost provoked a split, with each of the parties considering themselves to be more faithful to Freud's thought, but in the end the crisis was averted by a compromise that allowed the British Psychoanalytic Society to split into three subdivisions that have managed to coexist as well as could be expected. Meanwhile, in the United States, Karen Horney was kept out of the New York Institute, also for theoretical differences. In 1941, along with others who shared her "culturalist" views, she founded the Association for the Advancement of Psychoanalysis and the American Institute of Psychoanalysis. A series of splits followed, in Washington, Boston, and Los Angeles, while at the same time a number of associations for lay analysts were founded, such as the National Psychological Association for Psychoanalysis, founded by Theodor Reik in 1948. In 1987, this association was, after a long struggle, the cause of a reversal in I.P.A.'s policy on lay analysts.

In Germany after the war, theoretical grounds were used to settle scores for the positions that some had taken during the Nazi era. The German Psychoanalytic Society (*Deutsche Psychoanalytische Gesellschaft*, D.P.G.), which was reestablished in 1945 under the

strict leadership of Carl Müller-Braunschweig and Harald Schultz-Hencke, was a heterogeneous assembly that had hardly any conceptual or practical relationship with I.P.A.'s conception of psychoanalysis as represented at the Zurich Congress in 1949. Harald Schultz-Hencke advocated a "neo-psychoanalysis," and several of the group's members were more Jungian than Freudian. Thus Carl Müller-Braunschweig, in spite of the fact that his past did not inspire much confidence, was encouraged by those who held more orthodox views to found the German Psychoanalytic Association (*Deutsche Psychoanalytische Vereinigung*, D.P.V.), which was the only German group to be recognized by the I.P.A. as authorized to train analysts. The two groups would coexist until the German Psychoanalytic Society was eventually readmitted into the international psychoanalytic community.

Increasingly, problems of recruitment and training caused crises and splits within the international psychoanalytic movement. After World War II, the growing popularity of psychoanalysis and its geographical expansion linked to the exodus of analysts from Europe led to an increased demand for analysts and trainers in the western world.

The example of France is significant in this context. Young psychiatrists were already interested in psychoanalysis, but the creation of a bachelor's degree in psychology by Daniel Lagache in 1947 broadened this interest considerably. The decision to found a psychoanalytic institute in Paris triggered a struggle both for leadership and for authority over the candidates who began to flock to it. The outcome was the split of 1953, which left the Psychoanalytic Society of Paris (*Société psychanalytique de Paris*, S.P.P.) under the control of Sacha Nacht and led to the creation of the French Psychoanalytic Society (*Société française de psychanalyse*, S.F.P.) and a "free institute" co-directed by Daniel Lagache and Jacques Lacan. The new group then requested membership in the I.P.A., which, with an unprecedented intensity, took on the role of arbiter and even supreme authority in matters of training. Excluded from the I.P.A. by their own secession, the analysts of the S.F.P. fought for twelve years before their credentials as training analysts were granted. This recognition came at the price of excluding Jacques Lacan, who refused to comply with the norms that the I.P.A. imposed on analysts all over the world, such as the quantity and frequency of sessions in a

training analysis, the length of sessions, and the rituals concerning the required supervised analyses.

But conflicts over training reemerged after the foundation of the Freudian School of Paris (*École freudienne de Paris*, E.F.P.) by Jacques Lacan in 1964. A case in point was the split of 1969, when Piera Aulanger, François Perrier, and Jean-Paul Valabrega left to form the Quatrième Groupe (“Fourth Group” or O.P.L.F.). After Lacan dissolved the E.F.P. in 1980 and died the following year, the Lacanian movement suffered split after split, giving rise, in fact, to a plethora of small groups, most of them not very long-lived. In spite of its violent internal conflicts, the School of the Freudian Cause (*École de la Cause freudienne*, E.C.F.), the successor to the E.F.P., remained the most stable institution. Its longest lasting contemporary, the Center for Psychoanalytic Training and Research, broke up in 1995.

Psychoanalytic splits are often political, like the formation of the Psychoanalytic Seminar of Zurich in 1977, and often emotional, like the divisions over Kleinian theory in the Argentinean Societies. In the end, they are too numerous for a comprehensive overview. It has been impossible to give more than the most significant examples here. Nevertheless, they do have common features, among them emotional breakups, rebelliousness, and ideological schisms. Each split presents a mixture of these features in different proportions. Splits resemble emotional breakups insofar as old friendships are broken, transference bonds are brutally cut, and choices must be made. “It reminds you of parents who are divorcing,” as Anna Freud said in 1953 (Lacan, p. 72). As for “rebelliousness,” its traces are to be found in the new structures and regulations that arise, with much of the focus being on the functions of training, supervision, and so on. And ideological schisms, though generally masked by administrative operations, are always present. The fact that debates over ideas rarely reflect contrasting theoretical visions does not mean that they are any less vital. This is evident from the fact that every split is followed by a burst of creative activity on both sides.

It is possible to see in this last feature the invigorating potential of splits, which might otherwise seem like a kind of destruction. New, often formally unstable ideas can cause a definitive break, yet later they may reemerge in the mainstream of a psychoanalysis that is in perpetual evolution.

ALAIN DE MIJOLLA

*See also:* Adler, Alfred; American Academy of Psychoanalysis; Belgium; Congrès des psychanalystes de langue française des pays romans; École freudienne de Paris (Freudian School of Paris); France; Jahrbuch der Psychoanalyse; Jung, Carl Gustav; *Minutes of the Vienna Psychoanalytic Society*; Mouvement lacanien français; Netherlands; New York Freudian Society; Psychic causality; Quatrième Groupe (O.P.L.F.), Fourth group; Rank (Rosenfeld), Otto; Schweizerische Ärztgesellschaft für Psychoanalyse; Société française de psychanalyse; Société psychanalytique de Paris and Institut de psychanalyse de Paris; Switzerland (German-speaking); Training analysis; United States.

### Bibliography

- Jones, Ernest. (1953–1957). *Sigmund Freud. Life and work* (Vols. 1–3). London: Hogarth.
- Lacan, Jacques. (1990). *Television: A challenge to the psychoanalytic establishment*. (Joan Copjec, Ed., and Denis Hollier, et al., Trans.). New York: W. W. Norton. (Original work published 1974)
- Lockot, Regine. (1995). Mésusage, disqualification et division au lieu d’expiation. *Topique*, 57, 245–256.
- Mijolla, Alain de. (2001). Splits in the French Psychoanalytic movement between 1953 and 1964. In R. Steiner and J. Johns (Eds.), *Within Time and Beyond Time* (pp. 1–24). London: Karnac.
- Pines, Malcolm. (1995). La dissension dans son contexte: schismes dans le mouvement psychanalytique. *Topique*, 57, 191–206.
- Thompson, Nellie L. (1995). Les schismes dans le mouvement psychanalytique aux États-Unis. *Topique*, 57, 257–270.

---

## SPLITTING

Splitting is a form of dissociation that results from a conflict that can affect the ego (splitting of the ego) or its objects (splitting of the object). It is a very general intrapsychic process to the extent that it also forms the basis of the capacity in the psychic apparatus for dividing itself into systems (cf. first topography: unconscious, preconscious, conscious) and into agencies (cf. second topography: id, ego, superego).

The term “splitting” has some long-established uses in psychiatry and goes back to the general concept of a capacity for psychic splitting in the human being. These usages are precursors of the concept of splitting as defined by Freud. They are found in the nineteenth century in relation to hysteria and hypnosis (splitting



of the personality, multiple personalities, dissociation) and in Pierre Janet's work, in which the concept of a deficiency of psychological synthesis plays an important role. Freud and Breuer return to the concept of splitting in relation to "splitting of consciousness" and from 1894 ("The Psycho-Neuroses of Defence"), Freud provides a causality for this process: "For these patients whom I analysed had enjoyed good mental health until the moment at which *an occurrence of incompatibility took place in their ideational life*—that is to say, until their ego was faced with such an experience, an idea or a feeling which aroused such a distressing affect that the subject decided to forget about it because he had no confidence in his power to resolve the contradiction between that incompatible idea and his ego by means of thought-activity" (1894a, p. 47).

However, the splitting mentioned here goes back to neurotic repression. Now, Freud, writes, "There is, however, a much more energetic and successful kind of defence. Here, the ego rejects the incompatible idea together with its affect and behaves as if the idea had never occurred to the ego at all" (1894a, p. 58). This describes another form of splitting, that which Jacques Lacan later translates as foreclosure (*forclusion—Verwerfung*), which is characteristic of the psychoses and results in the foreclosed element returning in the real in the form of a hallucination. With the concept of "denial of reality," Freud introduces another form of splitting that demonstrates the proximity of the mechanisms of perversion to psychotic mechanisms without actually conflating them, as is evident from the creation of a substitute for the absent reality (the female penis) that occurs in the fetish, which differs from a hallucination.

The concept of splitting does not only concern this possibility of dissociation from reality or internal rift in the ego, but also relates to the object of the drive. Based on Freud's hypotheses concerning the life drive and the death drive, Melanie Klein demonstrated the force with which the latter operates in generating infantile anxiety when confronted with frustration. The splitting between a "loved good breast" and a "hated bad breast" therefore constitutes a way of simultaneously preserving a good object and constructing a bad object as the receptacle of the destructive drives. This situation corresponds to what the author terms the paranoid-schizoid phase. The support that the ego draws from the good object and the process of repairing the destroyed object subse-

quently allow this splitting to be partly overcome. However, the splitting of the object is inextricable from a splitting of the ego into a "good" and a "bad" ego, according to the introjection of the corresponding split objects. Splitting can prove difficult to overcome when it is established between a very bad object and an idealized object. The entire pathology of idealization opens up here with its multiple clinical facets.

Melanie Klein's successors, Wilfred Bion and Donald Winnicott, amplified and deepened the concept of splitting. For Bion, splitting in the form of dissociation precedes the work of elaboration in loss. For Winnicott, who takes up Helene Deutsch's concept of "false self," a distortion in the initial relationship between the mother-environment and the baby creates a false self that protects the true self but also isolates it from contact with reality. For Winnicott, splitting can also take the form of dissociation or disintegration as responses to being confronted with a psychotic fear of disintegration.

SOPHIE DE MIJOLLA-MELLOR

*See also:* Alcoholism; Alterations of the ego; Amnesia; Castration complex; Defense mechanisms; Ego; False self; Fetishism; Negative, work of; Perversion; Projective identification; "Some Psychological Consequences of the Anatomical Distinction Between the Sexes"; Splitting of the ego; Splitting of the object; "Splitting of the Ego in the Process of Defence, The"; Splitting (vertical and horizontal); Transsexualism.

### **Bibliography**

- Bion, Wilfred. (1962). *Learning from experience*. London: Heinemann.
- Klein, Melanie. (1935). A contribution to the psychogenesis of manic-depressive states. *International Journal of Psycho-Analysis*, 16, 145–174. Reprinted 1975 in *The writings of Melanie Klein*, vol. 1, 262–289.
- . (1952). The mutual influences in the development of ego and id. *Psychoanalytic Study of the Child*, 7, 51–53.
- Lacan, Jacques. (1966). *Commentaires sur la Verwerfung*. In *Écrits*. Paris: Le Seuil. (Original work published 1956)
- Winnicott, Donald W. (1953 [1951]). Transitional objects and transitional phenomena. A study of the first not-me possession. *International Journal of Psycho-Analysis*, 34, 89–97. Additional material was added to the paper in *Playing and reality*. London: Tavistock, 1971: 1–30.

## SPLITTING OF THE EGO

The term “splitting of the ego” refers to a division of the ego into two coexisting parts, one of which satisfies instinctual demands while the other heeds the objection, in the shape of a symptom, which reality raises to that satisfaction. This process, which Freud described as a “ruse,” constitutes a temporary response to the conflict, but the price paid is an inner rent in the ego that can only get worse with time.

For Freud the most striking instance of the splitting of the ego was to be observed in the perversion of fetishism, but it was also at work in the psychoses, and to a lesser degree in neurosis. It represents a position with respect to reality more complex than denial (or disavowal [*Verleugnung*]), for it implies the coexistence of two contradictory attitudes. The notion of the splitting of the ego was probably already present in embryo in Freud’s mind well before his paper on “Splitting of the Ego in the Process of Defence” (1940e [1938]). Thus the idea of a “plurality of psychical persons,” identifications, and in a more general sense the institution of the ideal mental agencies (superego, ego ideal) are so many forms of splitting of the ego—although it should be noted that in the last case the outcome is the formation of a new agency rather than the maintenance of a split within the ego itself.

It was above all in the context of the psychoses that Freud developed this idea, and especially with regard to paranoia and delusions of reference. Viktor Tausk also worked in this context in his discussion of the genesis of the “influencing machine” in schizophrenia (1919/1949). Similarly, Sándor Ferenczi (1933) pointed out that traumas experienced by the child might give rise to a dissociation of a kind that would enable the adult, later, to present an appearance of perfect adaptation concealing an ego in ruins. In Freud’s view, psychosis implied a break with reality caused by an irreconcilable idea: thanks to the mechanism of delusional projection, what had been abolished within the mind reappeared in the outside world in the shape of a hallucination.

The full dynamic complexity of the splitting of the ego emerged, however, only in the context of fetishism. Unlike a hallucination, a fetish was created not by a denial of reality but rather by a subtle avoidance of it, thanks to the symbolic transfer of the absent penis onto some other part of the body. This was the dividing-line between perversion and psychosis. But the

splitting of the ego also signaled the ego’s failure to build constructively on reality-testing by interpolating, between the instinctual demand and its gratification, the consequences of the envisaged course of action, whether the repression of the demand or the postponement of its satisfaction.

SOPHIE DE MIJOLLA-MELLOR

*See also:* Ego; Splitting.

### Bibliography

- Ferenczi, Sándor. (1949). Confusion of tongues between adults and the child: The language of tenderness and of passion. *International Journal of Psycho-Analysis*, 30, 225–230. (Original work published 1932)
- Freud, Sigmund. (1927e). Fetishism. *SE*, 21: 147–157.
- . (1940a [1938]). An outline of psycho-analysis. *SE*, 23: 139–207.
- . (1940e [1938]). Splitting of the ego in the process of defence. *SE*, 23: 271–278.
- . (1950a [1887–1902]). The origins of psycho-analysis. Extracts from the *Fliess papers*. *SE*, 1: 173–280.
- Tausk, Viktor. (1948). On the origin of the “influencing machine” in schizophrenia. In Robert Fliess (Ed.), *The psycho-analytic reader*. New York: International Universities Press. (Original work published 1919)

### Further Reading

- Blum, Harold P. (1983). Splitting of the ego and its relation to parent loss. *Journal of the American Psychoanalytic Association*, 31(S), 301–324.
- Lichtenberg, Joseph D., and Slap, Joseph W. (1973). Concept of splitting: Defense mechanisms; representations. *Journal of the American Psychoanalytic Association*, 21, 772–787.
- Pruyser, P.W. (1975). What splits in “splitting”? Scrutiny of concept. *Bulletin of the Menninger Clinic*, 39, 1–46.

## “SPLITTING OF THE EGO IN THE PROCESS OF DEFENCE”

This short essay, dating from January 1938, was published after Freud’s death. In this work Freud returned to an issue that he had previously discussed in “Fetishism” (1927e) and that he was to take up again in *An Outline of Psychoanalysis* (1940a [1938]).

The subject of ego splitting surfaced also in other much earlier texts, particularly those concerned with psychosis, which is why Freud hesitated between “whether what I have to say should be regarded as something long familiar and obvious or as something entirely new and puzzling” (1940e [1938], p. 275).

In the paper, Freud described as “cunning” (p. 277) the solution found by the child simultaneously to satisfy his instincts and respect reality. (It is surprising here that what Freud called a “real” danger was just the fact that the child had been threatened with castration.) Through the mechanism of splitting, the child “takes over the fear of that danger as a pathological symptom and tries subsequently to divest himself of the fear” (p. 275). The displacement of confrontation anxiety (onto a phobia, for example) allows for a particular solution, namely the creation of a fetish.

Freud goes on to describe how the “reality” of the threat is confused with the reality of the absence of a penis in the woman, falsely interpreted as a castration. Displacing the absent penis onto an object chosen as a fetish allows the child to disbelieve the threat of castration, since a substitute for the penis exists. However, this is only possible at the price of “a turning away from reality” (p. 277), an erroneous conception of female anatomy. Demarcating this mechanism from psychotic functioning is the fact that the substitute is not hallucinated but chosen in a regressive manner—that is, from a pregenital perspective. “Success,” Freud wrote, “is achieved at the price of a rift in the ego which never heals but which increases as time goes on” (p. 276).

This text has been much discussed, notably for its innovation in seeing the splitting of the ego as a process involved not only in fetishism and psychoses, but also in neuroses. Freud further developed this idea of ego splitting in *An Outline of Psychoanalysis* (1940a [1938]), where he described the splitting of the ego as “a universal characteristic of neuroses that there are present in the subject’s mental life, as regards some particular behaviour, two different attitudes, contrary to each other and independent of each other” (p. 204).

SOPHIE DE MIJOLLA-MELLOR

*See also:* Splitting.

### Source Citation

Freud, Sigmund. (1940e [1938]). Die Ichspaltung im Abwehrvorgang. *Internationaler Zeitschrift Psychoanalytischer Imago*, 25XXV, p. 241–244; *GW*, XVII, p. 57–62; Splitting of the ego in the process of defence. *SE*, 23: 271–278.

### Bibliography

Freud, Sigmund. (1927e). Fetishism. *SE*, 21: 147–157.

———. (1940a [1938]). An outline of psychoanalysis. *SE*, 23: 139–207.

---

## SPLITTING OF THE OBJECT

The early ego relates to its objects in partial ways; that is, it splits the object. This process creates objects characterized by a particular function (feeding, holding, and so on) or objects that frustrate or gratify (“bad” or “good” objects). The notion of splitting of the object appears for the first time in the article “Personification in the play of children” (Klein, 1929).

Melanie Klein in her earliest observations noted the wide discrepancies of children’s feelings toward objects in their attention. She was most impressed, and alarmed, by the strength of children’s aggressive and violent feelings toward objects they played with. Sometimes the child’s mood changed to aggression, anger, or fear very suddenly. In panics or tantrums this reaction could reach a rapid crescendo. Klein interpreted these hangovers from early infancy as the loss of the reality of the object. The object was no longer a person capable of mixed feelings of love and hate, and therefore of mixed intentions, beneficent or harmful. Instead, it became an object that was wholly loved or wholly hated. She regarded the early ego as not fully able to integrate the impressions of its first object. The breast, for example, is a good feeding object, or it is a frustrating one filled with hate and bad intent toward the infant.

As the ego matures, it becomes capable of recognizing that one and the same object can have good and bad aspects, as well as multiple functions. This perceptual development may, however, be distorted by emotional factors, with the result that the child, in its ways of relating, retains partial objects into childhood and later. Many prejudicial attitudes of race, class, gender, and so on, rely on distorted perceptions that enhance

one or another function, or the “good” or “bad” intent, to the exclusion of others. The capacity to integrate objects in accord with reality brings in powerful new emotional problems for the infant, who must harbor both hatred of a frustrating mother with love and gratitude toward her as a feeding mother. This integration leads to the depressive position and characteristic experiences of insecurity, guilt, pining, and reparation (Klein, 1935, 1940).

Melanie Klein derived her notion from Karl Abraham’s concept of partial object-love (1924). A splitting of the object is connected with a splitting of the ego; Klein (1946) thought that both must occur together. Freud’s last important theoretical contribution (1940e [1938]) concerned a splitting of the ego in connection with gross distortion of perceptions of the loved erotic object.

Anna Freud (1927) and Edward Glover (1945) have doubted that Klein could accurately describe the very early stages of development prior to the infant’s acquiring language. Klein, however, believed that her extrapolation from the analysis of young children back to infancy was no different from Freud’s extrapolation from the analysis of adults back to childhood.

Another dispute concerned the nature of objects. In classical psychoanalysis, objects are represented in the minds of adults and infants alike. However, Melanie Klein followed Karl Abraham in positing a level where objects are related to as real entities in psychic reality, be they concretely within the ego or outside.

ROBERT D. HINSELWOOD

*See also:* Envy and gratitude; Internal object; Linking, attacks on; Orality; Paranoid-schizoid position.

### **Bibliography**

- Abraham, Karl. (1927). The process of introjection in melancholia: two stages of the oral phase of the libido. In Douglas Bryan and Alix Strachey (Trans.). *Selected papers of Karl Abraham, M.D.* (pp. 442–452). London: Hogarth. (Original work published 1924)
- Freud, Anna. (1928). *Introduction to the technic of child analysis* (L. Pierce Clark, Trans.). New York: Nervous and Mental Disease Publishing Co. (Original work published 1927)
- Freud, Sigmund. (1940e [1938]). Splitting of the ego in the process of defence. *SE*, 23: 271–278.

Glover, Edward. (1945). Examination of the Klein system of child psychology. *Psychoanalytic Study of the Child*, 1, 75–118.

Klein, Melanie. (1929). Personification in the play of children. *International Journal of Psycho-Analysis*, 10, 171–182.

———. (1935). A contribution to the psychogenesis of manic-depressive states. *International Journal of Psycho-Analysis*, 16, 145–174.

———. (1936). Weaning. In John Rickman (Ed.), *On the bringing up of children*. London: Kegan Paul.

———. (1940). Mourning and its relation to manic-depressive states. *International Journal of Psycho-Analysis*, 21, 125–153.

———. (1946). Notes on some schizoid mechanisms. *International Journal of Psycho-Analysis*, 27, 99–110.

## **SPLITTING OF THE SUBJECT**

“Splitting” (in French, “refente”) is one of the translations Jacques Lacan proposed for the German “Spaltung” when he discussed how the subject is divided in subordination to the signifier.

In 1958, at the end of *Les formations de l’inconscient* (1998), book 5 of his seminar, Lacan introduced the written symbol to refer to the effects of the signifier on the subject. He proposed the French term “refente” some time later to translate the English term “splitting,” itself a translation of the term employed by Freud, “Spaltung,” which, in Lacan’s view, indicated this same dimension.

As early as 1953 Lacan emphasized an initial division “that precludes . . . any reference to totality in the individual.” This division differentiates the ego from the subject and consciousness from the unconscious. A person does not speak about the subject; the id speaks about it. A signifier represents the subject, but before disappearing under this signifier, the subject is nothing.

The signifier represents the subject for the signifier that exists in the Other (the primary caregiver). This operation alienates the subject, and through alienation produces the subject. The second operation is separation. It results in the splitting of the subject. There is no answer in the Other to the question of the subject’s being. Instead, the subject encounters the desire of the Other, that is, its own lack, the juncture where the subject’s fantasy will form.

The “division of the subject,” the term that Lacan used most frequently to translate “Spaltung,” corresponds to the written notation. Other words have also been proposed for this notion: not only “refente,” but also “coupure” (cut) and “évanouissement” (disappearance, vanishing) in French, as well as “eclipse,” “fading,” and “aphanisis” in English.

ALAIN VANIER

*See also:* Alcoholism; Alteration of the ego; Amnesia; Castration complex; Defense mechanisms; Ego; False self; Fetishism; Perversion; Projective identification; “Some Psychical Consequences of the Anatomical Distinction between the Sexes”; Splitting of the ego; “Splitting of the Ego in the Process of Defence”; Splitting of the object; Splitting, vertical and horizontal; Transsexualism.

### **Bibliography**

Lacan, Jacques. (1966). Du sujet enfin en question. *Écrits*, pp. 229–236. Paris: Seuil.

———. (1998). *Le séminaire*. Book 5: *Les formations de l'inconscient*. Paris: Seuil. (Delivered in 1957–1958)

---

## **SPLITTING, VERTICAL AND HORIZONTAL**

The psyche is often depicted metaphorically as an image, and this image can be further represented as whole or split. A horizontal splitting is used to bring out a division between upper and lower sectors. A vertical splitting suggests a separation of sectors that lie side by side. There is a psychoanalytic tradition that suggests that the first splitting (horizontal) represents repression, and the second (vertical) can be considered as a representation of denial.

A horizontal splitting, the barrier of repression, separates unconscious material from preconscious contents, while a vertical splitting basically partitions material that is more or less accessible to consciousness. While many are familiar with Sigmund Freud's ideas about repression and the forces that maintain it, the idea of vertical splitting is rather less well known. According to Heinz Kohut (1971), it is characterized by the existence, side by side, of attitudes operating on different levels—different structures of goals, aims, and moral and aesthetic values. Generally speaking, one side of this parallel existence is judged to be more in accord with reality, while the other can be judged infantile or turned towards immediate gratification.

One of the ways of considering these parallel attitudes of the personality consists in saying that the realist attitude is better structured and/or more neutralized, while the infantile attitude is relatively unstructured and/or not neutralized. This less structured sector is sometimes involved in a fantasy, but with even less structure it can issue in manifest action. Such is the case with behavioral disturbances such as addictions, delinquency, and perversions. With horizontal splitting, the infantile and unstructured material is kept at bay. With vertical splitting, it succeeds in expressing itself. Pathological behavior is the manifestation of this split vertical sector.

ARNOLD GOLDBERG

*See also:* Sexualization; Splits in psychoanalysis.

### **Bibliography**

Goldberg, Arnold. (1995). *The problem of perversion*. New Haven: Yale University Press.

Kohut, Heinz. (1971). *The analysis of the self*. New York: International Universities Press.

---

## **SQUIGGLE**

The squiggle was Donald Winnicott's technique of communicating with children through drawing, in psychotherapeutic consultation. First he would make a “squiggle,” a twisted or wiggly line spontaneously drawn on a piece of paper. The child then adds elements to the drawing, and the analyst and child comment on its meaning. The analyst then transforms the child's drawing, and the analyst and child further comment on the drawing. This interview diagnostic is based on the idea of testing a therapeutic response.

Winnicott described the game first in 1958 and later more fully, with a series of case studies, in 1971. During his career as both pediatrician and psychoanalyst, Winnicott developed techniques in his work with children that were at once diagnostic and frequently therapeutic, based on his view that creative communication and play both occur in the “third area” or “area of experiencing”—the space between persons where contributions from each overlap.

Winnicott's concept of the “third area,” “transitional area,” or “area of experiencing” derives from his thinking about the infant's development from the

early illusory stage of omnipotence to the stage of recognizing objective reality, and is linked to his ideas about transitional objects and phenomena. An earlier example of communicating with and observing an infant is given in his description of the “spatula game” (Winnicott, 1941).

In both games, Winnicott observed the responses of all parties in the interaction: in the spatula game, the responses of mother, baby, himself, and any observer; in the squiggle game, his own and the child’s spontaneous actions and comments.

His description of the squiggle game is exquisitely detailed: how he met the child and introduced the game, how he took pains to diminish possible anxiety, and how he allowed the child, if the child wished, to decline this invitation to play.

Winnicott discovered that this technique, in the setting provided by him, provided reference to current emotional difficulties and also to their roots in developmental and structural reality. The clinical descriptions given in his writings are detailed and give an insight into the mind and work of this unique psychoanalyst and pediatrician. Winnicott’s widow, Clare, described Winnicott’s own enjoyment of his private squiggles, which he would draw after work each day. A collection of them is held in the Archives of the British Psychoanalytical Society.

Winnicott’s description of his technique has inspired other analysts, who have found it useful, although some analysts have leveled the criticism that his spontaneity and his own particular facility for communicating with children were idiosyncratic and are difficult to reproduce.

Melanie Klein also made use of play as a technique, though she used her technique in ongoing psychoanalysis rather than in diagnostic or therapeutic consultations. Anna Freud as well made use of play with children.

JENNIFER JOHNS

*See also:* Technique with children, psychoanalytic; Winnicott, Donald Woods.

### **Bibliography**

Winnicott, Donald. (1941). The observation of infants in a set situation. *International Journal of Psycho-Analysis*, 22, 229–249.

———. (1958). Symptom tolerance in paediatrics. In his *Collected papers: Through paediatrics to psycho-analysis* (pp. 101–117). London: Tavistock Publications. (Originally published in 1953)

———. (1968). The squiggle game. In *Voices: The art and science of psychotherapy*, 4 (1).

———. (1971). *Therapeutic consultations in child psychiatry*. London: Hogarth Press and the Institute of Psycho-Analysis.

## **STAGE (OR PHASE)**

The term “stage” is used to designate a developmental phase that, for Freud, is characterized by a specific organization of the libido, linked to a particular erotogenic zone, and dominated by a particular modality of object relations. Some authors prefer to speak of “phases” or “positions” rather than stages, because these alternatives emphasize the fact that what are referred to here are moments in psychosexual development that partake of the dialectic of the Oedipus complex, rather than a precisely stable stage in the evolution of the libido. Each phase of sexual development corresponds in effect to a distinct type of organization.

Thus the psychoanalytic notion of stage does not refer to the structural study of the genesis of cognitive processes, nor does it impinge on the field of developmental psychology (for instance, the theory of Jean Piaget). The Freudian approach concerns itself exclusively with the child’s developing psychosexuality constructed in “stages,” “phases,” or “organizing moments” as the child proceeds through various steps in its maturation.

This perspective attempts to account for the constitutive effects, during childhood, of bodily and mental experiences of pleasure and unpleasure, and hence for the role played by the erotogenic zones at two levels: object relationships and narcissism, or love and hate—the basic modes of mental life, which the successive versions of Freud’s theory of the instincts sought to explicate. From this standpoint, the scheme of libidinal stages provides a set of reference points, a grid against which the specific traits of an individual’s mental organization can be plotted and clearly profiled (Brusset, 1992).

Both psychopathology and the psychology of the ego have used a scheme of stages as a main axis of reference. In psychopathology, this general model

makes it possible to relate pathological structures (character types, disease entities) to various fixations or regressions of the libido. One of the most remarkable demonstrations of the consistency of the model is the association between obsessional neurosis and the anal character type. The essential role that anal eroticism plays in obsessional neurosis led Freud to define the anal-sadistic stage as a major moment in the organization of the psyche. This account served as his initial model for a general conception of “stages of organization of the libido.” On the basis of his analysis of the “Rat Man” (1909d), Freud was able to define the dynamic organization and structure of obsessional neurosis by drawing out the close connections between sadomasochism and anal eroticism. Similarly, Freud’s analysis of the autobiography of Daniel Paul Schreber (1911c [1910]) served as the basis for Freud to relate paranoia to a fixation at the narcissistic stage of development and to relate dementia praecox (schizophrenia) to a fixation at the autoerotic stage.

In the psychology of the ego (Anna Freud, René Spitz, Otto Fenichel) and ego psychology (Ernst Kris, Heinz Hartmann, and Rudolph Loewenstein), sets of problems are tackled in terms of developmental stages—a development that brings the notions of regression and fixation into their own. These two ideas stand in contrast with those of evolution, process, and change. From the genetic point of view, fixation, as a factor in invariable and repetitious behavior, is a constraint imposed by the instinctual unconscious. Regression may be pathological (as when it becomes fixated, for example), but it may also be purely functional and part of normal development, notably when it occasions narcissistic reinforcement as preparation for resuming the dynamic process of object cathexis (Golse, 1992).

When Freud abandoned his theory of seduction, he inevitably gave new weight to fantasy and emphasized psychic over material reality. Fantasies, it should be remembered, are scenarios of action first constructed in an autoerotic period and tending to actualize mnemonic traces of the experience of satisfaction. This theoretical step called for a metapsychology, rather than a simple psychology of the lower, normal, and rational forms of human mental activity that confines its scope to conscious phenomena alone. Thus the system of stages could remain a valid theory only if it was integrated into a properly psychoanalytic framework, one that took account, in particular, of the notions of the unconscious and of repression. Early experience

includes the body, but also the unconscious sexuality of the mother (Perron-Borelli, 1997).

The object is both a constitutive element of the instinct and a pole of cathexis within external reality. The notion of object relations has tended to enhance the general impact of the model of stages. In particular, it has opened this model up to the diversity and complexity of parent-child interaction, lessening the former emphasis on pressure and source (that is, on the erotogenic zones) and stressing instead the two other defining aspects that make the libidinal instinct into a complete structure, namely the aim and the object (Brusset, 1992).

Psychoanalytically speaking, the genetic dimension is necessarily related in a dialectical manner to the structural dimension, that is, the oedipal organization and its different triangulations. Jean Laplanche and Jean-Bertrand Pontalis (1973) have pointed out that the use of the terms “phase” or “position” instead of “stage” underscores the fact that we are concerned here with intersubjective moments within the oedipal dialectic, rather than mere stages of libidinal development. The concept of deferred action (*après coup*) also runs counter to a purely linear view of mental development in which each stage is understood as unfolding in simple opposition to the preceding one. For example, deferred action, operating in conjunction with the diphasic nature of human sexuality, results in a period of latency.

In an even more radical sense, the fundamental Freudian ideas of the timeless unconscious and of a compulsion to repeat serve to explain how a past of which the subject has no memory can return in the shape of “a perpetual recurrence of the same thing” (1920g, p. 22).

The Freudian model of libidinal development has been vulnerable to simplifying uses that threaten, in particular, to dissolve metapsychology into a naively realistic psychology or else into a psychology of the ego and of development that retains nothing of psychoanalysis. All the same, quite apart from the explanatory value of structural approaches, the practice of psychoanalytic interpretation, founded on a reconstruction of the past, continues to derive inspiration from a genetic point of view: “The task is certainly to account for structures in terms of the processes that have constituted them, and for processes in terms of the stages that make them intelligible” (Brusset, 1992).

A model based on stages, if it is to remain pertinent, must therefore remain subordinate to the metapsychology of mental processes, and by extension, it must remain dialectically consonant with the structural perspective.

JEAN-FRANÇOIS RABAIN

*See also:* Abraham, Karl; Anaclisis/anaclitic; Anal-sadistic stage; Catastrophic change; Cruelty; Disintegration products; Fragmentation; Genital stage; Good-enough mother; Group; Hallucinatory, the; Hatred; Infans; Libidinal stage; Libido; Mirror stage; Organization; Oral stage; “On the Origin of the ‘Influencing Machine’ in Schizophrenia”; Partial drive; Phallic stage; Preenatal; Primary identification; Psychosexual development; Psychotic/neurotic; Quasi-independence/transitional stage; Self (true/false); Sexuality; Squiggle; Symbiosis/symbiotic relation; Tenderness; Transitional object, space; *Violence of Interpretation, The: From Pictogram to Statement.*

### **Bibliography**

- Brusset, Bruno. (1992). *Le développement libidinal*. Paris: Presses universitaires de France.
- Freud, Sigmund. (1909d). Notes upon a case of obsessional neurosis. *SE*, 10: 151–318.
- . (1911c [1910]). Psycho-analytic notes on an autobiographical account of a case of paranoia (dementia paranoides). *SE*, 12: 1–82.
- . (1920g). Beyond the pleasure principle. *SE*, 18: 1–64.
- Golse, Bernard. (1992). *Le Développement affectif et intellectuel de l'enfant*. Paris: Masson.
- Laplanche, Jean, and Pontalis, Jean-Bertrand. (1973). *The language of psycho-analysis* (Donald Nicholson-Smith, Trans.). London: Hogarth Press and the Institute of Psycho-Analysis. (Original work published 1967)
- Perron, Roger, and Perron-Borelli, Michèle. (1997). *Fantasme, action, pensée*. Algiers, Algeria: Éditions de la Société algérienne de psychologie.
- Perron-Borelli, Michèle. (1997). *Dynamique du fantasme*. Paris: Presses Universitaires de France.

## **STAMMERING**

Stammering is a disorder in the rate of speech delivery. It appears in the communication patterns of children aged between two and five and is characterized by repetitions or blockages that lead to ruptures in the

rhythm and melody of speech. Three out of four children are destined to overcome it before adolescence. Stammering is a universal complaint and has been documented in the most ancient cultures.

Sigmund Freud associated this type of disorder with hysteria, but classified it separately as a fixation neurosis (on an organ [of speech]). Otto Fenichel located this functional speech disorder in the group of pregenital conversion neuroses. The patient's mental structure was the same as that of an obsessive, whereas the symptomatology was of the conversion type. Speech had acquired an unconscious significance related either to its verbal content or to the general meaning of the function of “speaking” itself, as in severe cases of stammering in which the speech act represents a reprehensible drive.

Bernard Barrau draws attention to the frequent presence of situations of oral violence in these cases, and fantasies of “forcible introduction,” whether in relation to forced food or its metaphorical equivalents (the voice and speech of the mother). Ivan Fonagy stresses the fact that speech is capable of absorbing narcissistic, oral, anal, or genital libido, and reports observations of parallel strategies in the anal and glottal sphincter (stammering when establishing sphincter control), and upward transfers of anal libidinal cathexis (one of Charlotte Balkany's patients identified resonant air with air emitted by the anal sphincter). René Diatkine points to the absence of a psychic structure specific to stammering subjects, whose symptom, as a disorder in verbal communication, modifies their relational system, particularly the balance between narcissistic- and object-cathexes.

Annie Anzieu traces the elements in the neurotic dynamics of stammering subjects. An anal-sadistic relation is often established between the (grasping and abusive) mother and the child, with the child fixating on a dual, merging relation with the mother, excluding all connections to a third object, unless it takes part in the mother-child whole. Stammerers thus have difficulty in engaging oedipal problems. Supervisions must be redoubled in order to integrate oedipal prohibitions into the ego, because what enters the body or comes out of it assumes a new erotic meaning. The speech act permanently alludes to castration anxiety. This relational mode leads to the persistence of what Melanie Klein calls the paranoid-schizoid position. Indeed the stammerer is persecuted by a particularly demanding father and mother. All



verbal emissions are problematic. Like feces, words are experienced as aggressive objects whose true intentions may be to wound or kill. They become the concrete symbols of interiorized aggressive objects. These paranoid characteristics entail a considerable obsessional element as well. Stammerers exhaust their discourse to the point of fragmentation; they remain haunted by the specific words they should be saying. Obsessional cathexis of discourse can be understood in the process of neurotic construction as a superegoic symptom in relation to the hysterical symptom stammering constitutes. The phonetic dysfunction and suffering caused by verbal emission are a form of hysterical conversion, a conversion that lends genital significance to an originally anal-sadistic symptom. The stammerer expresses the conflict he has always experienced through his symptom; the subject hides behind it. The act of speaking conceals what is said. The psychotherapy or psychoanalysis of stammerers always evinces these hysterical, obsessional, and paranoid contents in a more or less typical fashion depending on the moment in treatment and patient in question. For Nicole Fabre, stammering is an archaic difficulty shot through with oral aggressivity and anal sadism, from which the subject has not yet been able to break free in order to fully accede to oedipal triangulation.

Although psychoanalytic treatment is rarely indicated initially, especially with children, this approach does provide an understanding of the disorder that does not exclude its meaning from the outset.

The etiology of stammering is unknown. Constitutional factors interact with environmental ones in addition to factors linked to the personal dynamics of the child in varying proportions depending on the subject in question, thus illustrating the uniqueness of the trouble each stammerer faces.

CHRISTIAN PAYAN

See also: Tics.

### **Bibliography**

- Anzieu, Annie. (1989). De la chair au verbe. In *Psychanalyse et langage: Du corps à la parole* (pp. 103–127). Paris: Dunod. (Original work published 1977)
- Barrau, Bernard. (1989). Bégaiement et violence orale. In *Psychanalyse et langage: Du corps à la parole*. Paris: Dunod. (Original work published 1977)

Fabre, Nicole. (1986). *Des cailloux plein la bouche*. Paris: Fleurus.

Fenichel, Otto. (1953). Respiratory introjection. In *The collected papers, first series*. New York, W.W. Norton.

Fonagy, Ivan. (1983). *La Vive Voix: essais de psycho-phonétique*. Paris: Payot.

Freud, Sigmund, and Breuer, Josef. (1895d). *Studies on hysteria*. SE, 2: 48–106.

---

## **STANDARD EDITION OF THE COMPLETE PSYCHOLOGICAL WORKS OF SIGMUND FREUD**

This was the title given by James Strachey in 1948, and adopted by the British Psycho-Analytical Society Memorial Appeal, to the English translation of all of Freud's psychoanalytic works. In accordance with Freud's wishes, the *Standard Edition* does not include Freud's prepsychoanalytic work as a neurologist.

The *Standard Edition*, which consists of twenty-four volumes published between 1943 and 1974, was prepared by James Strachey and his wife, Alix, with the collaboration and supervision of Anna Freud and the help of Alan Tyson. The twenty-fourth volume of the *Standard Edition*, which includes the "General indexes" and the "Addenda and corrections," was edited and published in 1974 by Angela Richards, a collaborator of the late James Strachey. In addition to the English translation, the *Standard Edition* also contains "Notes on some technical terms whose translation calls for comment," edited by Strachey, who made use of the old *Glossary of Psychoanalytical Terms*, published in 1924 and edited by Ernest Jones, and of Alix Strachey's *New German-English Psychoanalytical Vocabulary*, published in 1943. Furthermore, the *Standard Edition* has a considerable editorial apparatus: the introduction to each work of Freud's establishes its various dates of publication in German, English, or other languages; the context in which the text has to be read, in terms of the progression of Freud's work; the links that can be made with Freud's earlier and later work; and all the additions or deletions Freud made if a specific text, such as *The Interpretation of Dreams*, had more than one edition in German. In some instances, Strachey and his coworkers tried to check the various German editions of each text, and Strachey also added explanatory and informative notes at the

end of each of the texts that he and his colleagues translated.

One of the main organizational problems of the *Standard Edition* concerned the rights of translation into English, which Freud had given to his nephew Edward Bernays and to Abraham Arden Brill in America. For decades this made Strachey's task of a systematic translation of Freud's work impossible. For instance, only as late as 1949 was Strachey able to retranslate *The Interpretation of Dreams*.

Ernest Jones first conceived of the project of preparing a standard edition of Freud's work in English in the early 1920s (Steiner, 1989). Together with Abraham A. Brill, he had already translated many of Freud's technical terms into English when he was in America at the beginning of the twentieth century (Steiner, 1987). He sent James Strachey and his wife and then Joan Riviere and John Rickman to Vienna to be analyzed by Freud, with the added intention of creating a team of translators who could then systematically translate Freud into English and take over the leadership of Freud's translations from Abraham Brill. The result of those first systematic attempts were the first four volumes of Freud's *Collected Papers*, which were translated by the Stracheys, Joan Riviere, and others, often under the supervision of Jones, and were published in the 1920s and 1930s in London. It is important to remember this, since there is a clear line of continuity between the translations done by Jones and his group of translators in the 1920s and 1930s and the *Standard Edition*. Strachey did not make many changes to the *Glossary of Psychoanalytical Terms*, published in 1924 for translators and edited by Ernest Jones, which already contained translations for the most famous and questionable technical terms: "ego" for "Ich," "superego" for "Über-Ich," "instinct" for "Trieb," and so on. To Strachey in particular are attributed the translations of "cathexis" for "Besetzung" (a term, incidentally, also accepted by Freud) and "anaclitic" for "Anlehnung." All four volumes of the *Collected Papers* were republished in the *Standard Edition*, with corrections and improvements; apart from the papers on metapsychology, which had been badly translated, Strachey did not make many alterations to the translations done in the 1920s.

The *Standard Edition* reflects not only the personal idiosyncrasies of the Stracheys but also Jones's project to create in English a scientific Freud acceptable to

the medical and scientific psychiatric establishment. Although Jones and the Stracheys in the 1920s disagreed on many aspects of how to translate Freud (Meizel, 1986) Jones and James Strachey consulted each other constantly on technical and interpretative matters even during the 1950s, when they were working on the biography of Freud and on the *Standard Edition*. The supervision of the translation was also important, particularly by Anna Freud. Like any other translation, the *Standard Edition* bears the marks of the cultural context in which it was conceived; the complex political, institutional, and financial pressures that surrounded this colossal enterprise; and the personalities and ageing of the translators, James and Alix Strachey. Among the shortcomings of the *Standard Edition* were that Freud's polysemous, elegant, and expressive literary vocabulary and style were at times excessively stifled and rendered scientific, and that its editorial apparatus was inevitably restricted by the information, documents, personal letters, and notes of Freud's life and work available at that time. Yet there is no doubt that the *Standard Edition* constitutes a unique and irreplaceable instrument for the study of Freud. Perhaps one of the most amazing achievements of the *Standard Edition* is that other translations and editions of Freud's work depended on the *Standard Edition* rather than on the original German texts.

RICCARDO STEINER

*See also:* British Psycho-Analytical Society; Great Britain; Second World War: The effect on the development of psychoanalysis; Hogarth Press; Jones, Ernest; Ego; Scopophilia/scopophilia; Strachey, James Beaumont; Strachey-Sargent, Alix; *Studienausgabe*.

### Bibliography

- Bettelheim, Bruno. (1983). *Freud and man's soul*. New York: Alfred A. Knopf.
- Freud, Sigmund. (1924–1950). *Collected papers* (5 vols.). London: International Psycho-Analytical Press.
- Jones, Ernest (Ed.). (1924). *Glossary of psychoanalytical terms*.
- Mahony, Patrick. (1980). Toward the understanding of translation in psychoanalysis. *Journal of the American Psychoanalytic Association*, 28, 461–473.
- . (1982). *Freud as a writer*. New York: International Universities Press.

Ornston, Darius Gray. (1992). Improving Strachey's Freud. In Darius Gray Ornston (Ed.), *Translating Freud*. New Haven, CT: Yale University Press.

Steiner, Riccardo. (1987). A world-wide international trademark of genuineness? *International Review of Psychoanalysis*, 14, 33–102.

———. (1989). On narcissism: The Kleinian approach. In Otto F. Kernberg (Ed.), *Narcissistic personality disorder* (pp. 741–770). Philadelphia: W. B. Saunders.

———. (1991). To explain our point of view to English readers in English words. *International Review of Psychoanalysis*, 18, 351–392.

Strachey, Alix. (1943). *New German-English psychoanalytical vocabulary*.

Strachey, James. (1966). General preface. In *Standard edition of the complete psychological works of Sigmund Freud* (Vol. 1, pp. 13–26). London: Hogarth.

---

## STATE OF BEING IN LOVE

The concept of “being in love” was investigated by Christian David in *L'État amoureux*, published in 1971, at a time when his ideas about psychosomatics were changing. David continued to believe in the importance of questioning the fluctuations to which mental processes were exposed, but he now stressed those generated through the encounter with the other rather than those implied by a physical presence.

Overall, his study attempts to point out the internal behavior of the subject confronted, through this encounter, with the state of “being in love.” For David this state is characterized by a form of subjectification that has two components: the subjectification of the drive in the face of the specific trauma caused by love, and the ability to integrate the narcissistic release implied by the encounter with the loved one. With respect to the subjectification of the love trauma, Sigmund Freud, who is quoted by David, sees it as similar to the work of mourning or dreaming. The analogy enables him to emphasize the singular quality of this type of activity, where the drive is immobilized at the crossroads of destiny and constantly re-released through the encounter with the other. Through this encounter the subject is constantly forced to confront the necessary death of the ego. “Where love is awakened, ego, that somber despot dies,” writes David, repeating Freud's quote of Jalal el Din (1911c).

One of the basic premises of David's book is to explain love as a narcissistic disturbance. The con-

comitant risk of forcing the subject to confront the most primitive dimensions of the drive is one that may restore the condition of narcissism. These aspects are at work in the tragedy of *Penthesilea* by Heinrich von Kleist, a text for which David provides a psychoanalytic reading. In the myth Penthesilea, queen of the Amazons, is in love with Achilles and loved by him. In the end she kills her lover and devours him with the help of her dogs. However, the violence of the drama underscores the necessity of a two-sided abandonment: abandonment of proximity to the being onto whom the subject projects his ideal, and abandonment of preserving intact the contours and limits of the ego. While the work of mourning flattens the contours of experience, the mental work required by the love trauma restores to it the variety and truth of its nuances. But to do this requires subjectification. At the extreme, this subjectification can assume the aspect of an “affective perversion,” like that expressed by Nathaniel in Gide's *The Fruits of the Earth*, when he exclaims, “My desires have given me more than the possession of the object of those desires.” In a sense the work implied by being in love, including “affective perversion,” mirrors the effort therapy demands of the patient caught up in transference love.

LAURENT DANON-BOILEAU

See also: Empathy; Friendship; Racker, Heinrich.

### Bibliography

- David, Christian. (1971). *L'État amoureux*. Paris: Payot.
- . (1980). Metapsychological reflections on the state of being in love. In Lebovici, Serge, and Widlocher, Daniel. *Psychoanalysis in France*. (p. 87–100) New York: International Universities Press.
- . (1996). Post-scriptum à l'état amoureux. *Revue française de psychanalyse*, 60, 3, 633–642.
- Freud, Sigmund. (1911). Psycho-analytic notes on an autobiographical account of a case of paranoia (dementia paranoides). *SE* 12: 1–82.
- . (1921). Group psychology and the analysis of the ego. *SE* 18: 65–143.

---

## STEKEL, WILHELM (1868–1940)

An Austrian physician and psychoanalyst, Wilhelm Stekel was born on March 18, 1868, at Boyan, Buko-

vina. He died on June 25, 1940, in London. After matriculating from a German secondary school in Czernowitz, Stekel studied medicine in Vienna. He worked in Richard von Krafft-Ebing's clinic for a while before defending his thesis in 1893.

A certain mystery surrounds the date of Stekel's first meeting with Freud, as well as that of the analysis (or analyses) that he undertook with him. In his paper "The Aetiology of Hysteria" (1896c), Freud cites Stekel's "Über Coitus im Kindesalter" (On infantile sexuality; 1895), and in another article written in 1896 but published in the following year, Stekel mentioned Freud's report on Paul Julius Möbius's book on migraine. It was probably Freud who, in 1901, recommended Stekel for a position as medical journalist at the well-known newspaper *Neues Wiener Tagblatt*, in whose pages, in January 1902, Stekel published a complimentary article on Freud's *Interpretation of Dreams* (1900a).

In October 1902, Stekel initiated setting up the Wednesday Psychological Society, which in 1908 transformed itself into the Vienna Psychoanalytic Society. Judging by the minutes (Nunberg and Federn), Stekel was its most active member during the first ten years. Stekel strongly challenged Freud on such subjects as the harmfulness of masturbation and the existence of the actual neuroses. In 1910 Stekel proposed setting up *Zentralblatt für Psychoanalyse*, of which he was soon sole editor. A dispute about his rights in this office led to Stekel's resignation from the Vienna Psychoanalytic Society in 1912. The underlying reason, however, was almost certainly Stekel's refusal to accept Freud's ideas on the actual neuroses. After World War I, Stekel set up his own school of "active analysis" and founded the Organisation of Independent Medically Qualified Analysts. He also launched and edited a number of psychotherapeutic journals.

Stekel was a prolific writer, producing fifty books (many of them for a general readership), hundreds of newspaper articles, and numerous scientific papers. The most important part of Stekel's psychoanalytical work is contained in his ten-volume *Störungen des Trieb- und Affektlebens* (Disturbances of the impulses and the emotions). The first volume was *Conditions of Nervous Anxiety and Their Treatment* (1923). It was followed by volumes on masturbation and homosexuality, frigidity in women, impotence in men, psychosexual infantilism, peculiarities of behavior, fetishism,

sadism and masochism, and finally two volumes on compulsion and doubt. Other academic books of his deserving special mention are *Die Sprache des Traumes* (The language of dreams; 1911), *Die Träume der Dichter* (The Dreams of Poets; 1912), *The Interpretation of Dreams* (1943), and *Technique of Analytical Psychotherapy* (1939). The most well-known of his popular books was his *Primer for Mothers* (1931).

Stekel was a popularizer of psychoanalytic ideas, both through his journalistic output and through his books, yet he was also an innovator in technique and theory. He devised a form of short-term therapy called active analysis, which has much in common with some modern forms of counseling and therapy. He argued strongly for the view that all neuroses are psychoneuroses.

FRANCIS CLARK-LOWES

See also: Wiener psychoanalytische Vereinigung; *Zentralblatt für Psychoanalyse*.

### Bibliography

- Freud, Sigmund. (1896c). The aetiology of hysteria. *SE*, 3: 186–221.
- Nunberg, Hermann, and Federn, Ernst. (1962–1975). *Minutes of the Vienna Psychoanalytic Society*. New York: International Universities Press.
- Stekel, Wilhelm. (1895). Über coitus im Kindesalter: eine hygienische studie. *Wiener medizinische Blätter*, 16, 247–249.
- . (1911). *Die sprache des traumes*. Wiesbaden, Germany: J. F. Bergmann.
- . (1912). *Die träume der dichter*. Wiesbaden, Germany: Bergmann.
- . (1923). *Conditions of nervous anxiety and their treatment* (Rosalie Gabler, Trans.). London: K. Paul, Trench, Trubner and Co.
- . (1926). Zur geschichte der analytischen Bewegung. *Fortschritte der Sexualwissenschaft und Psychoanalyse*, 2, 539–575.
- . (1931). *A primer for mothers* (Frida Ilmer, Trans.). New York: Macaulay Co.
- . (1939). *Technique of analytical psychotherapy* (Eden and Cedar Paul, Trans.). London: John Lane.
- . (1943). *The interpretation of dreams: New developments and technique* (Eden and Cedar Paul, Trans.). New York: Liveright Publishing Corp.

———. (1950). *The autobiography of Wilhelm Stekel: The life story of a pioneer psychoanalyst*. New York: Liveright.

## STERBA-RADANOWICZ-HARTMANN, EDITHA (1895–1986)

Psychoanalyst Editha Sterba was born on May 8, 1895, in Budapest, and died December 2, 1986, in Detroit, Michigan.

From a Catholic family, Editha was the daughter of Colonel Heinrich von Radanowicz-Hartmann, a commander in the Austrian army. After secondary education at a humanistic gymnasium ordinarily restricted to boys, she attended the University of Vienna, where she initially studied German language and literature and classical philology before turning, in 1916, to musicology. She graduated in 1921 with a thesis on “Viennese Song from 1789 to 1915.”

As secretary to Otto Rank at the Internationaler Psychoanalytischer Verlag (the official psychoanalytic publishing house) and secretary at the training institute, she became familiar with analysis, and by the end of 1925 she was an associate member of the Vienna Psychoanalytic Society. A year later, divorced from her first husband, she married the Viennese physician and analyst, Richard Sterba. In June 1927, she gave a lecture “Blasphemy and the Punishment of Heaven” and in 1930 she became a full member of the Vienna Society.

Editha Sterba’s major focus was the emerging field of child psychoanalysis. In 1928, she was placed in charge of the educational services center of the Vienna Psychoanalytic Society and, in 1932, of a larger center with August Aichhorn, Anna Freud, and Willi Hoffer. With Aichhorn she also served as an adviser and consultant to educational institutions in Vienna and, in October 1934, she directed the introductory seminar on child psychoanalysis. From 1927, she regularly published her works in *Zeitschrift für psychoanalytische Pädagogik*.

The Sterbas left Vienna in 1938, first for Switzerland. On Ernest Jones’s advice, they applied for a visa for South Africa with the intention of helping to found a psychoanalytic society there. However, they failed to obtain the necessary visas and instead emigrated to the United States in 1939. Editha became a member of the Detroit Psychoanalytic Society, the American Psychoanalytic Association, the Association for Child Psycho-

analysis and, in 1955, of the Michigan Association for Psychoanalysis. In 1953, she was asked to join the newly opened department of psychiatry at Wayne State University. Her study *Beethoven and His Nephew*, written in collaboration with her husband, appeared in 1954. With Alexander Grinstein she wrote *Understanding Your Family*, published in 1957.

Editha Sterba played a variety of roles in organizational and research projects over the course of three decades in the United States. She worked at the Children’s Service of the McGregor Center at Wayne State University and the Northeast Guidance Clinic; she also helped found the Roeper City and Country School, a training institution for nurses. She was associated with the University of Michigan, practiced at the Children’s Hospital of Michigan, and for the Jewish Family Service she developed methods for treating young survivors of the Holocaust.

ELKE MÜHLEITNER

*See also:* Lehrinstitut der Wiener Psychoanalytischen Vereinigung; Sterba, Richard F.

### Bibliography

Mühlleitner, Elke. (1992). *Biographisches lexikon der psychoanalyse (die mitglieder der psychologischen Mittwoch-Gesellschaft und der Wiener Psychoanalytischen Vereinigung 1902–1938)*. Tübingen: Diskord.

Sterba, Editha. (1929). Nacktheit und scham. (Nudity and shame). *Zeitschrift für psychoanalytische Pädagogik*, 3.

———. (1941). The school and child guidance. *Psychoanalytic Quarterly*, 10, 445–467.

———. (1945). Interpretation and education. *Psychoanalytic Study of the Child*, 1, 309–318.

Sterba, Editha, and Grinstein, Alexander. (1957). *Understanding your family*. New York: Random House.

Sterba, Editha, and Sterba, Richard F. (1954). *Beethoven and his nephew; a psychoanalytic study of their relationship*. New York: Pantheon.

## STERBA, RICHARD F. (1898–1989)

Richard Sterba, physician and psychoanalyst, was born in Vienna on May 6, 1898, and died on October 24, 1989, in Grosse Pointe, Michigan. His father, Josef Sterba, taught mathematics and physics at the high school level. Conscripted shortly before graduating

from the gymnasium in 1916, Richard entered the army and was eventually promoted to lieutenant. While in the military, he became interested in psychoanalysis and, after the war, began medical studies at the University of Vienna, graduating in 1923. The next year he started a training analysis with Eduard Hitschmann; without sufficient funds, he paid no fee, on the understanding that in the future he too would analyze some patients for free. His first supervising analyst was the neurologist Robert Hans Jokl, and he began treating patients after six months of analysis.

In 1926 Sterba married Editha von Radanowicz–Hartmann, and the couple were among the first students to attend the training institute of the Vienna Psychoanalytic Society, which opened at the end of 1924. Sterba became an associate member of the society in 1925 and a full member in 1928 (Sterba, 1982, p. 43). Shortly after presenting his 1926 paper, “Über latent, negative Übertragung” (On latent negative transference), Wilhelm Reich offered him a residency at a psychoanalytic outpatient clinic (Sterba, 1982, p. 40). Leaving his hospital position, he worked at the clinic with Grete Bibring and Eduard Kronengold. By 1929 Sterba was a training analyst, and in 1931 Adolf Josef Storfer, director of a psychoanalytic publishing house, suggested that he compile a psychoanalytic dictionary. Five fascicles of the lexicon were published (1936) before the coming of the Second World War put an end to the project.

Sterba was still in Austria in 1938, when the Nazi takeover of the country immediately disrupted psychoanalysis there. As a member of the board of directors of the Vienna Psychoanalytic Society, Sterba announced his intention to leave the country, to the relief of Freud and his daughter Anna, who themselves would soon migrate to England. As an “Aryan,” Sterba was welcomed by the Nazis, but he declined a post at the neuropsychiatric clinic of the University of Vienna and also rejected an offer to head the Vienna Psychoanalytic Society under fascist auspices.

The Sterbas left Austria on March 16, 1938, first for Switzerland then, in 1939, for the United States. Ernest Jones and Anna Freud suggested that they immigrate to Johannesburg and help found a psychoanalytic society there, but the South African government thwarted these plans by denying them visas. They settled in Detroit, where Richard Sterba founded the Detroit Psychoanalytic Society in 1940 and served as its president from 1946 to 1952. He was appointed

Professor of Psychiatry at the medical college of Wayne State University in Detroit in 1945.

Sterba specialized in psychoanalytic profiles of artists and published a study of Michelangelo and, in collaboration with his wife, a biography of Beethoven. In clinical matters, his hypothesis of “a therapeutic split of the ego” was controversial (Sterba, 1982, p. 91). In 1931 he published in German a treatise on the theory of the libido based on a course he taught at the Vienna Psychoanalytic Institute. In 1942 an English translation appeared under the title *Introduction to the Psychoanalytic Theory of the Libido*. In 1982 he published his memoir, *Reminiscences of a Viennese Psychoanalyst*. He was the author of about one hundred articles, a number of which appear in *Richard Sterba: The Collected Papers* (1987).

ELKE MÜHLEITNER

See also: Sterba–Radanowicz–Hartmann, Editha.

### Bibliography

Freud, Sigmund. (1936b [1932]). Preface to Richard Sterba's *Handwörterbuch der psycho-analyse*. *SE*, 22: 253.

Sterba, Edith, and Sterba, Richard. (1954). *Beethoven and his nephew: A psychoanalytic study of their relationship*. New York: Pantheon.

Sterba, Richard F. (1936). *Handwörterbuch der psychoanalyse*. Vienna: Internationaler psychoanalytischer Verlag.

———. (1942). *Introduction to the psychoanalytic theory of the libido*. New York: Nervous and Mental Disease Monographs. (Original work published 1931)

———. (1982). *Reminiscences of a Viennese psychoanalyst*. Detroit: Wayne State University Press.

———. (1987). *Richard Sterba: The collected papers*. New York: North River Press.

---

### STOLLER, ROBERT J. (1925–1991)

American psychoanalyst, professor of psychiatry, UCLA Medical School, was born December 15, 1925, in Crestwood, New York and died on September 6, 1991, in Los Angeles.

He was born and raised in suburban New York to Russian-Jewish immigrant parents, attended Columbia University and Stanford Medical School, was married for 43 years, and had four sons. Stoller underwent

psychoanalytic training at the Los Angeles Psychoanalytic Society and Institute from 1953 to 1961 with analysis by Hanna Fenichel. He was the author of nine books, co-author of three others, and publisher of over one hundred and fifteen articles. Stoller's writing is unique in its clarity and accessibility as well as its critical perspective on psychoanalytic methodology.

Stoller is known for his theories and research concerning the development of gender and the dynamics of sexual excitement. In *Sex and Gender* (1968), Stoller articulates a challenge to Freud's belief in biological bisexuality. Drawing on his extensive research with transsexuals at UCLA's Gender Identity Clinic and new advances in the science of sex, Stoller, in "Primary Femininity," advances his belief in the initial orientation of both biological tissue and psychological identification toward feminine development. This early, non-conflictual phase contributes to a feminine core gender identity in both boys and girls unless a masculine force is present to interrupt the symbiotic relationship with mother. Stoller identifies three components in the formation of core gender identity, an innate and immutable sense of maleness or femaleness, usually consolidated by the second year of life: 1) Biological and hormonal influences; 2) Sex assignment at birth; and 3) Environmental and psychological influences with effects similar to imprinting. Stoller asserts that threats to core gender identity are like threats to the sense of self and result in the defenses known as perversions.

In his most notable contribution, *Perversion* (1975), Stoller attempts to illuminate the dynamics of sexual perversion which he fights valiantly to normalize. Stoller suggests that perversion inevitably entails an expression of unconscious aggression in the form of revenge against a person who, in early years, made some form of threat to the child's core gender identity, either in the form of overt trauma or through the frustrations of the oedipal conflict.

In *Sexual Excitement* (1979), Stoller finds the same perverse dynamics at work in all sexual excitement on a continuum from overt aggression to subtle fantasy. In focusing on the unconscious fantasy, and not the behavior, Stoller provides a way of analyzing the mental dynamics of sexuality, which he terms "erotics," while simultaneously de-emphasizing the pathology of any particular form of behavior. Stoller does not consider homosexuality as a monolithic behavior but rather as a range of sexual styles as diverse as heterosexuality.

Less well known is Stoller's contribution toward making psychoanalysis a legitimate research tool through the publication of the analyst's data—verbatim notes and transcripts of interviews. Stoller melds the work of the ethnographer and the analyst as a means of producing scientifically valid psychological data. Many of Stoller's books, like *Splitting* (1973), are devoted to the documentation of the interviews on which he based his research.

CHRISTOPHER GELBER

*Notion developed:* Sexual identity.

*See also:* Homosexuality; Perversion; Principle of identity; Transsexualism; Voyeurism.

### **Bibliography**

- Stoller, Robert J. (1968). *Sex and gender: On the development of masculinity and femininity*. New York: Science House.
- . (1973). *Splitting: A case of female masculinity*. New York: Quadrangle Books.
- . (1975). *Perversion: The erotic form of hatred*. New York: Pantheon.
- . (1979). *Sexual excitement: dynamics of erotic life*. New York: Pantheon.
- . (1985). *Observing the erotic imagination*. New Haven, London: Yale University Press.
- . (1985). *Presentations of gender*. New Haven, London: Yale University Press.

---

## **STONE, LEO (1904–1997)**

Leo Stone, American psychoanalyst and teacher, was born on August 11, 1904, in Brooklyn, New York, where he died on July 27, 1997. He was the third of four children born to Ruben and Marcia Stone. His father, a man "with a good heart," was an avid reader and owned a large library, through which Leo read systematically. His mother was a kind woman with a fine singing voice—a factor in Leo's love of music. During his childhood the family moved to a farm north of New York City. Seven years later they moved back to Brooklyn. Later in life, Leo purchased from Brooklyn College a tract of land across the state line in New Jersey, an act reflecting his early attachment to nature. He was married twice and was the father of three daughters.

Leo Stone graduated from Erasmus High School in Brooklyn in 1916, from Dartmouth College in 1924, and from Michigan University Medical School in 1928. After a year on call, he studied pathology in Vienna and Berlin in 1930 and then completed a residency in neurology at Montefiore Hospital. He trained in psychiatry at the Menninger Clinic until 1936, after which he started a private practice in New York City, which he continued until his death.

He graduated from the New York Psychoanalytic Institute in 1941, having been analyzed by Clara Thompson, an analysand of Sándor Ferenczi. Then he joined the faculty of the institute and was active for many years until late in his life. He was Brill Memorial lecturer and received many honors and awards. He served as president of the New York Psychoanalytic Institute and as president of the New York Psychoanalytic Society. From 1951 to 1957, he also served as medical director of the New York Psychoanalytic Society.

Stone first achieved prominence after Anna Freud approvingly discussed his paper “The widening scope of indications for psychoanalysis” (1954), a plea for humanely expanding the use of psychoanalysis to treat a broad range of illnesses. This paper became the basis of his best known book, *The Psychoanalytic Situation: An Examination of Its Development and Essential Nature* (1961). He also published *The Therapeutic Experience and Its Setting: A Clinical Dialogue with Robert Langs* (1980) and *Transference and Its Context: Selected Papers in Psychoanalysis* (1984).

A key participant in the historic 1971 International Psychoanalytic Congress in Vienna, where he spoke on aggression as a reaction to frustrating reality rather than an inborn drive—a view with which Anna Freud concurred. He was an early proponent of a flexible approach. His view was that an analyst who remained too rigid risked damaging his patient and undoing any treatment—a view that was radical at a time when analysts favored giving the silent treatment or acting as a reflecting mirror.

Stone was widely respected in the United States for being gentlemanly and courteous, kind and modest, and lucid and thorough in presenting psychoanalytic ideas and concepts.

ZVI LOTHANE

*See also:* Abstinence/rule of abstinence.

### Bibliography

- Stone, Leo. (1938). Concerning the psychogenesis of somatic illness: Physiological and neurological correlates with the psychological theory. *International Journal of Psycho-Analysis*, 19, 63–76.
- . (1947). Transference sleep in a neurosis with duodenal ulcer. *International Journal of Psycho-Analysis*, 28, 86–118.
- . (1954). The widening scope of indications for psychoanalysis. *Journal of the American Psychoanalytic Association*, 2, 567–594.
- . (1961). *The psychoanalytic situation: An examination of its development and essential nature*. New York: International Universities Press.
- . (1980). *The therapeutic experience and its setting: A clinical dialogue with Robert Langs*. New York: Jason Aronson.
- . (1984). *Transference and its context: Selected papers on psychoanalysis*. New York: Jason Aronson.

---

### STORFER, ADOLF JOSEF (1888–1944)

Adolf Josef Storfer, journalist and publisher, was born in Botoschani, Siebenbürgen (now in Romania) on January 11, 1888, and died in Melbourne, Australia, on December 2, 1944.

He was of Jewish origin and his father was a well-to-do wood merchant. He grew up at Klausenburg (Cluj), where he completed his secondary education and began to study law and political science. In 1908 he went to Zurich to continue his studies and became a journalist for the *Frankfurter Zeitung* and other publications.

In 1910 he contacted Sigmund Freud and sent him his manuscript “Zur Sonderstellung des Vatermordes” (“On the Primordial Role of Father Murder”), which Freud published that same year in *Schriften zur angewandten Seelenkunde* (“Writings of Applied Psychology”). In 1913 Storfer settled in Vienna and attended the meetings of the Wednesday Society.

He was mobilized during World War I and in 1919 became a member of the Hungarian Psychoanalytic Society, before moving back to Vienna. From 1921 onward he collaborated with the Internationaler Psychoanalytischer Verlag, becoming director in 1925. Until 1932 Storfer left his print on the content and editorial policy of this powerful instrument for the dissemination of psychoanalysis. His solid humanistic



education and his vast general culture particularly suited him to this task, as did his experience as a journalist.

The Internationaler Psychoanalytischer Verlag had its most productive period between 1925 and 1932: three new periodicals were founded and the publication of Freud's *Gesammelte Schriften* was completed under Storfer's directorship, along with his personal contributions to the content.

His contacts with the members of the Vienna Psychoanalytic Society were somewhat half-hearted, as he never practiced psychoanalysis. His role was essentially to be the intellectual indicator of Sigmund Freud's editorial policy. As editor of publications and as a result of internal financial crises, Storfer often had to deal with the competing interests of the psychoanalysts, as well as the consequences of the economic crisis.

As a leftist liberal intellectual, he frequented one of the most fashionable cafes in Vienna, the Café Herrenhof. In 1932 he left the Verlag after bitter disputes, thereafter working as a self-employed journalist, and publishing two works on etymology: *Wörter und ihre Schicksale* ("Words and their Destiny") and *Im Dickicht der Sprache* ("In the Thicket of Language").

In 1938 he succeeded in fleeing to Shanghai at the last minute and worked there as an editor for the last time. From 1939 to 1941 he published one of the best German-language newspapers for exiles, the *Gelbe Post*. As the Japanese advanced, in 1941, he managed to flee to Australia with the help of the British intelligence services. As a result of pneumonia he died in Melbourne in 1944 in extreme poverty.

INGRID SCHOLZ-STRASSER

See also: *Almanach der Psychoanalyse*; *Gesammelte Schriften*; Internationaler Psychoanalytischer Verlag; *Mysteries of a Soul*; Sterba, Richard F.

### **Bibliography**

Mühlleitner, Elke. (1992). *Biographisches Lexikon der Psychoanalyse (Die Mitglieder der Psychologischen Mittwoch-Gesellschaft und der Wiener Psychoanalytischen Vereinigung 1902–1938)*. Tübingen: Diskord.

Leupold Löwenthal, Harald, Lobner, Hans, and Scholz Strasser, Inge (Eds.). (1995). *Sigmund Freud Museum: Berggasse 19, Vienna* (Thomas Roberts, Trans.). Corte Madera, CA: Gingko Press.

Scholz Strasser, Inge. Newsletter. *Sigmund Freud House bulletin* 1991, 15 (1), 40–48.

## **STRACHEY, JAMES BEAUMONT (1887–1967)**

James Strachey, British psychoanalyst, was born in London on September 26, 1887, and died there on July 3, 1967. He belonged to a very distinguished upper-middle-class family. He studied at St. Paul's School in London, achieving good academic results, and in 1904 went to Trinity College, Cambridge, to study classics. Owing to personal difficulties, he ended up not with a degree in classics but with an unclassified degree in moral sciences (1909). Like many other pioneers of the British Psycho-Analytical Society at Cambridge, Strachey discovered the Society for Psychical Research, where he read Freud's paper "A Note on the Unconscious in Psycho-Analysis," published in the society's journal in 1912. It was this paper that stimulated Strachey's interest in psychoanalysis.

He had a brief career as a journalist working in London for *The Spectator* and *The Athenaeum*, during which time he also became part of the Bloomsbury Group, led by his brother Lytton. In 1919 he approached Ernest Jones about becoming a psychoanalyst. He married Alix in 1920. In the same year Jones, having perceived Strachey's literary talents and wanting to use him to begin the systematic translation of Freud's work into English, sent him to Vienna to be analyzed by Freud. While in analysis with Freud, who chose him officially as his translator, James, together with Alix, began to translate several of Freud's works, such as "A Child is Being Beaten" (1919e) and "Group Psychology and the Analysis of the Ego" (1921c). This was done under Freud's supervision and with the help of Anna Freud, who then became his collaborator and counselor in translating Freud's works.

Strachey returned to London in 1922 and, while practicing as a psychoanalyst, nevertheless dedicated most of his time to translating Freud's work. Particularly important was the Stracheys' translation of five of Freud's case histories, published in 1925 as the third volume of Freud's *Collected Papers*. James became an associate member of the British Psycho-Analytical Society in 1922, a full member in 1922, and a training analyst in 1928.

As a training analyst, Strachey took an active part in the life of the British Psycho-Analytical Society, then under the rule of Ernest Jones, who as early as the 1920s had already planned what was to become, after the Second World War, the *Standard Edition of the*

*Complete Psychological Works of Sigmund Freud.* Strachey helped Melanie Klein to come to London and played an important mediating role in the controversial discussions between Anna Freud and Melanie Klein in the 1940s. In 1948 Strachey became the general editor of the *Standard Edition* translation of all the psychological works of Freud into English, and after retiring to the country at Marlow with his wife, he dedicated the rest of his life to accomplishing this task, using and revising the translations made in the 1920s by him, Joan Riviere, and others that had appeared in the first four volumes of Freud's *Collected Papers* and retranslating other works such as *The Interpretation of Dreams* and the metapsychological papers. One of the greatest contributions of his work was the editorial apparatus that he added to the translations of the *Standard Edition*, which has become invaluable in understanding and contextualizing Freud's work.

Strachey was well aware that his translations and editorial apparatus were not definitive and that they would need further revisions and corrections. Particularly important was the glossary of psychoanalytic terms, which he prepared reusing old material and most of the terminology already established in the 1920s and published in 1924 in *The Glossary of Psychoanalytical Terms*, edited by Ernest Jones. To Strachey we owe, among other translations, the terms "cathexis" to translate the German "Besetzung" and "anacletic" to translate "Anlehnung." Both terms were derived from ancient Greek. Indicating the importance of its translations and editorial apparatus is the fact that the *Standard Edition* has become the text used by the International Psychoanalytical Association and that it is also the point of reference for other translations of Freud's works into such major languages as German, Italian, Spanish, Portuguese, and French. In 1967 Strachey was awarded the Tieck Prize for his translation of the *Standard Edition*.

Strachey also significantly contributed to clinical psychoanalysis on his own. One paper particularly deserving to be remembered is "The Nature of the Therapeutic Action of Psycho-Analysis" (1934). This paper is considered a landmark for its discussion of problems related to the interpretation and mutative effects of transference.

RICCARDO STEINER

*Notion developed:* Transmuting internalization.

*See also:* British Psycho-Analytical Society; Controversial Discussions; Empathy; Great Britain; Hogarth Press; *International Journal of Psychoanalysis*, *The*; Libido; Maturation; Neutrality/benevolent neutrality; Primary identification; "Project for a Scientific Psychology, A"; Psychoanalytic semiology; Resolution of the transference; Scopophilia/scopophilia; *Standard Edition of the Complete Psychological Works of Sigmund Freud*; Strachey-Sargent, Alix; *Studienausgabe*; Time.

### **Bibliography**

- Freud, Sigmund. (1912g). A note on the unconscious in psycho-analysis. *SE*, 12: 255–266.
- Holroyd, Michael. (1973). *Lytton Strachey: A critical biography*. London: Heinemann.
- Ornston, Darius Gray. (1992). Improving Strachey's Freud. In Darius Gray Ornston (Ed.), *Translating Freud* (pp. 1–23). New Haven: Yale University Press.
- Meisel, Perry, and Kendrick, Walter. (1986). *Bloomsbury-Freud: The letters of James and Alix Strachey, 1924–1925*. London: Chatto and Windus.
- Steiner, Riccardo. (1987). A world-wide international trademark of genuineness? *International Review of Psychoanalysis*, 14, 33–102.
- . (1991). To explain our point of view to English readers in English words. *International Review of Psychoanalysis*, 18, 351–392.
- Strachey, James. (1934). The nature of the therapeutic action of psycho-analysis. *International Journal of Psycho-Analysis*, 15, 127–159.

---

### **STRACHEY-SARGENT, ALIX (1892–1973)**

Alix Strachey, British psychoanalyst was born on June 4, 1892, in Nutley, New Jersey, and died in London on April 28, 1973.

She came from a rather complex but highly intellectual family background and her childhood was quite erratic due to family problems. Educated at Bedales School and then at the Slade School of Art in London, she went up to Cambridge in 1911, where she graduated with a degree in modern languages in 1914. Through her brother Philip and other friends she met at Cambridge, Alix took part in the life of the Bloomsbury Group where she met James Strachey, whom she married in 1920. She became an associate member of the British Psycho-Analytical Society in 1922 and a full member in 1923.

She had a personal analysis in Vienna with Freud for two years from 1920 to 1922, as did her husband. It was during this period that she began helping her husband to translate Freud's work into English. She then went to Berlin for further analysis with Karl Abraham in 1924. In Berlin, she continued her translation work and met Melanie Klein. Alix was instrumental in arranging Klein's first visit to London in 1925 and translated some of her papers into English. Together with her husband, she published the translation of Freud's *Five Case Histories*, which were assembled in the third volume of his *Collected Papers* (1925). She finally returned to England after Abraham's death in December 1925.

She undertook other personal analyses: with Edward Glover in 1926 and later with Sylvia Payne. She took part in the administrative life of the British Psycho-Analytical Society but her main contributions were in the field of translation, helping to translate Freud's and others' papers into English. For instance, in collaboration with Douglas Bryan, she translated *The Selected Papers of Karl Abraham* (1927) and Klein's *Psychoanalyse der Kindes—The Psychoanalysis of Children* in 1932. She also translated Freud's *Inhibitions, Symptoms and Anxiety* in 1936. In 1943 she published *A New German-English Psychoanalytical Vocabulary*, a complete index of psychoanalytic terms in English which was instrumental for the *Standard Edition*. The rest of her time, from the late forties until the late sixties, she was dedicated to helping James publish the *Standard Edition*. It is sometimes difficult to evaluate Alix's contribution, which has, nevertheless, been invaluable as far as the *Standard Edition* is concerned. When the *Standard Edition* was well advanced, Alix was able to dedicate herself to some more personal work, going back to the interests of her youth: social issues, war, and pacifism. She published *The Unconscious Motives of War* in 1957 and *The Psychology of Nationhood* in 1960.

RICCARDO STEINER

See also: British Psycho-Analytical Society; Great Britain; Hogarth Press; *Inhibitions, Symptoms, and Anxiety*; Klein-Reizes, Melanie; Strachey, James Beaumont.

### **Bibliography**

Holroyd, Michael. (1973). *Lytton Strachey: A critical biography*. London: Heinemann.

Meisel, Perry, and Kendrick, Walter. (1986). *Bloomsbury-Freud. The letters of James and Alix Strachey 1924–1925*. London: Chatto and Windus.

## **STRANGER**

Fear of strangers (or stranger anxiety) is a normal emotional response that occurs in the second half of the first year of life; the concept was introduced and developed by René Spitz, who called it "eight-month anxiety."

This construction was the result of direct observation from a developmental psychoanalytic perspective. The fear of strangers reaction signals a point where development has encountered a difficulty or even gone off track. According to Spitz's conceptual framework, as outlined in "Anxiety and Infancy" (1950), eight-month anxiety marks a decisive phase in object relations: the infant's mental accession to object permanence. This is in contrast to the social smiling of the preceding period, which is addressed indifferently to both unknown and familiar faces, and comes after archaic pre-objectal fears and anxieties. It is referred to as the "first genuine manifestation of anxiety" (Spitz and Cobliner, 1965; Spitz 1968), and thus figures in interpretations and differences of opinion relating to separation anxiety and theories of anxiety in general.

Spitz's principle of "organizers" of mental life places eight-month anxiety as the second organizer. However the embryological metaphor implied by the term "organizer" has been contradicted by demonstrations of early interactive capacities in babies, while fear of strangers has been marginalized within metapsychology by attachment theory, which has attracted many adherents. John Bowlby argues that intrusions upon the primary need for attachment cause the infant to reject the traumatizing face. Serge Lebovici developed the concept of eight-month anxiety into a primary phobia with the proposed name "Stranger's-Face Phobia." This is a proto-phobia that unfolds via displacement onto the stranger of the infant's aggressive impulses against the mother. Thus it both protects her imago and appeals to her return. From the viewpoint of current psychosomatic theories of mental development in France (Pierre Marty), stranger anxiety evinces the emergence of various psychic functions. The absence of stranger anxiety is a symptom of mental deficiencies and is a remarkable indicator of the silence of the mechanisms of inter-relational and

intra-psychical defense, which may be discerned from six to twelve months in disorders such as eczema (already observed by Spitz), asthma, anorexia nervosa, and the severe disorders caused by deficiencies in maternal care which are categorized under the name “empty behavior syndrome” (Léon Kreisler).

The distinction between separation anxiety and stranger anxiety has been clinically proven by the fact that they appear independently of one another. When it is not experiencing acute sensitivity to separation, the separated child (*le petit allergique*) is all smiles to whomever it sees, stranger and familiar alike, like the baby described in the first of Spitz’s organizers. As pure affect deprived of representation that repeats the baby’s distress at being separated from the mother, anxiety separation affords a view onto the future development of eight-month anxiety, which is itself a prototype of object-anxieties, and hence the original prototype for mental development itself.

LÉON KREISLER

*See also:* Infant development.

### **Bibliography**

Spitz, René A. (1950). Anxiety in infancy. *International Journal of Psycho-Analysis*, 31.

## **STRATA/STRATIFICATION**

In psychoanalysis, the term “stratification” refers to the layers of ideation constructed by the psyche. In *Studies on Hysteria* (1895d), Freud noted, “Thus it came about that in this, the first full-length analysis of a hysteria undertaken by me, I arrived at a procedure which I later developed into a regular method and employed deliberately. This procedure was one of clearing away the pathogenic psychical material layer by layer, and we liked to compare it with the technique of excavating a buried city” (p. 139).

Exploring the theme in greater detail in the chapter entitled “The Psychotherapy of Hysteria,” he stated that his aim was a “dynamics of ideation” (p. 287). “The psychical material,” he explained, “presents itself as a structure in several dimensions which is stratified in at least three different ways” (p. 288). First is a reverse linear chronology, “as though we were examining a dossier that had been kept in good order” (p. 288). Second is a concentric stratification around

the pathogenic nucleus, where resistance increases as one gets closer to the nucleus. Here the strata represent zones of “an equal degree of modification of consciousness” (p. 289). Finally, there is dynamic stratification, which follows thought contents. Dynamic stratification is revealed by trajectories that zigzag from the surface down into the deep strata and back up again, passing through all levels and convergent nexuses of communication. The overdetermination of symptoms results from this type of stratification.

The problem of the stratification of the psyche, and thus of a “dynamics of ideation,” remained a constant preoccupation for Freud from then on. Indeed, psychoanalysis itself can be characterized as a psychology of depths. To explore these depths of the psyche, Freud developed topographies in writings spanning from *The Interpretation of Dreams* (1900a) through “Splitting of the Ego in the Process of Defence” (1940e [1938]). But the topographies were not enough. Freud also posited different temporalities within the psyche, such as the atemporality of the unconscious. Also playing a part in Freud’s elaboration of the structure of the psyche were phylogenetic traces of an archaic heritage, fixation, regression, and the life and death instincts. Described in “The Ego and the Id” (1923b) as the “precipitate of abandoned object cathexes” (p. 29), the ego too exhibits considerable stratification. What happens at the boundaries between the various strata and among the agencies of the mind can also be characterized as strata dynamics.

In mathematics, a stratified set is made by stitching together varieties of different dimensions. Catastrophe theory sheds light on the dynamics capable of generating these stratifications and on modes of passage from one stratum to another. This could be an outstanding tool for linking together the questions raised by Freud.

MICHÈLE PORTE

*See also:* Analyzability; Archaic; Archaeology, metaphor of; Biological bedrock; Fusion/defusion of instincts; History and psychoanalysis; Id; Instinctual impulse; Libidinal stage; Mnemic trace/memory trace; Proton-pseudos; Psychic revision; *Studies on Hysteria*.

### **Bibliography**

Freud, Sigmund. (1900a). The interpretation of dreams. *SE*, 4: 1–338; 5: 339–625.

———. (1923b). The ego and the id. *SE*, 19: 1–66.

———. (1925a [1924]). A note upon the “mystic writing pad.” *SE*, 19: 225–232.

———. (1930a [1929]). Civilization and its discontents. *SE*, 21: 57–145.

———. (1940e [1938]). Splitting of the ego in the process of defence. *SE*, 23: 271–278.

Freud, Sigmund, and Breuer, Josef. (1895d). Studies on hysteria. *SE*, 2: 48–106.

Teissier, Bernard. (1988). Stratifications, finitude et intuition. In Jean Petitot-Cocorda (Ed.), *Logos et théorie des catastrophes: à partir de l'œuvre de René Thom; Actes du colloque international de 1982* (pp. 59–65). Geneva: Patino.

## STRUCTURAL THEORIES

A *structural* theory may be defined as one which tends to organize a set of propositions—and, in the realm of the natural sciences, a set of observations to which they refer—as a whole made up of interdependent parts. A *structure* may be defined as a functional whole presiding over a system of transformations and governed by self-regulating mechanisms.

Such a definition applies equally well to inanimate material systems (self-regulating machines), to constructions of the mind (logico-mathematical wholes, as for instance set theory), to living organisms, or to subsystems of living organisms. This last category would include the psychical apparatus in Freud's sense, and that apparatus can thus be deemed the object of a structural theory in psychoanalysis.

From its earliest formulations, Freudian metapsychology may indeed be looked upon as a structural theory according to the above definition, for it was meant to describe the functioning of a system made up of interdependent elements, namely the psychical apparatus as a whole. This was clear in Freud's work as early as the “Project for a Scientific Psychology” (1950c [1895]) and his reformulation of the ideas of the “Project” five years later in *The Interpretation of Dreams* (1900a). During this first period in the development of psychoanalysis, Freud was already specifying local aspects of an overall functioning. After describing how ideas are linked together, for instance, he observed that their concatenations crossed at “nodal points” which it was the task of analysis to locate: “The logical chain corresponds not only to a zigzag, twisted line, but rather to a ramifying system of lines and more particularly to a converging one. It

contains nodal points at which two or more threads meet” (1895d, p. 290). Sometimes, even, several interconnected nodes were observable, like those constituting what Freud called a “pathogenic organization.”

The whole of Freud's subsequent work strove for an ever more refined and better articulated description of the operation of the psychical apparatus as a structure, and this at a number of levels. It is thus possible to distinguish those writings in which Freud described partial, local aspects of that operation in terms of a network—as, for example, the breast-feces-penis-money interplay of symbolic equivalents—and indeed the term *complex* itself denotes such a local organization; those writings concerned with modalities of overall mental functioning characteristic of particular groups of individuals (for example, the obsessional structure); and those writings whose subject was the general laws of mental functioning. Two major stages in Freud's approach to these laws were represented by the metapsychological papers of 1915 and by his introduction in the 1920–1923 period of a second topography and a second theory of the instincts.

The structural view was always paralleled in Freud by a developmental approach to the same issues. If one accepts the idea that any structure may be apprehended in terms of its genesis (the successive stages of its establishment), and that any genetic process presents its own diachronic structure, it would seem that the two perspectives must be inextricably linked. The structural and the developmental have nevertheless often been opposed to each other by psychoanalysts, who have privileged one to the detriment of the other.

This separation has been spurred by two currents of thought. The first, within psychoanalysis itself, accompanied the advent of child psychoanalysis and of theoretical options that stressed development. The chief figures here were Anna Freud, Melanie Klein, and their more or less direct heirs, among them Margaret Mahler, Frances Tustin, Donald Meltzer, Donald W. Winnicott, and Serge Lebovici. In the wider general cultural framework, a second contributing factor was the “structure-versus-history” debate that stirred up so many disciplines during the nineteen-seventies (Green, 1963). The origins of that debate may be traced back to linguistics, to the moment around 1910 when Ferdinand de Saussure introduced an avenue of research which treated language as a system of signs each of which derived its meaning from its

relationship with the others: in other words, a structural approach to language sharply opposed to the hitherto dominant diachronic one. This orientation was further refined later by many linguists, notably by Roman Jakobson, who inspired Jacques Lacan. In another area, Claude Lévi-Strauss revolutionized traditional cultural anthropology by asserting that the kinship relationships observable in any given society were structures, and added that in all societies the taboo on incest was “the rule of rules.”

It is important to note that two major schools of thought, though radically at odds with one another, considered themselves, or were considered by others, to be “structural” psychoanalysis. The first was “ego psychology,” developed above all in the United States under the influence of Heinz Hartmann. The qualifier “structural” refers in this instance to ego psychology’s embrace of the second Freudian topography, in which the id-ego-superego system—a set of polarities and complementarities—unquestionably implies a structural conception of psychoanalysis, as envisaged in the latter part of Freud’s work. Inasmuch, however, as the developmental axis was dominant for the ego psychologists, French-speaking authors have tended to characterize their doctrine as “genetic psychoanalysis,” and in many cases expressed strong reservations about what they deemed an “objectivist realism” which by overvaluing “direct observation” of children’s behavior was liable to water psychoanalysis down into a mere developmental psychology.

In any event, Jacques Lacan is thought to stand in diametrical opposition to ego psychology, referring directly as it does to Saussure, Jakobson, and Lévi-Strauss. For Lacan language constituted the paradigmatic structure of the psyche, and more especially of the unconscious, which he therefore described as “structured like a language.” Language was a system of signs none of which signified anything in itself, for meaning arose solely from the place and function of a given sign within the system as whole. In his later work, however, Lacan distanced himself somewhat from this linguistic orientation and called upon logico-mathematical models borrowed from topology, notably metaphorical uses of the Möbius strip and the Borromean chain. He was led eventually to distinguish three main types of structures in the sense of modalities of the functioning of a whole: the structures of neurosis, marked by repression, the structures of per-

version, characterized by disavowal, and the structures of psychosis, produced by foreclosure.

ROGER PERRON

*See also:* Actual neurosis/defense neurosis; *Anti-Oedipus: Capitalism and Schizophrenia*; Autism; Autoeroticism; *Beyond the Pleasure Principle*; Blank/nondelusional neuroses; Brain and psychoanalysis, the; Change; Partial drive; Consciousness; Danger; Determinism; Addiction; Dualism; Ego boundaries; Fear; Group analysis; *Group Psychology and the Analysis of the Ego*; Ideology; Infantile, the; Mentalization; Narcissism; Object; Object-relations theory; Operational thinking; Perversion; Phobic neurosis; Primary process/secondary process; Processes of development; *Psychanalyse, La*; Psychic causality; Psychoses, chronic and delusional; Psychosexual development; Psychosomatic limit/boundary; Representation; Schizophrenia; Symbol; *Totem and Taboo*; Transference neurosis; United States.

### **Bibliography**

- Beres, David. (1965). Structure and function in psychoanalysis. *International Journal of Psycho-Analysis*, 46, 53–63.
- Blum, Harold P. (1971). Transference and structure. In Mark Kanzer (Ed.), *The unconscious today: Essays in honor of Max Schur*. New York: International Universities Press.
- Fédida, Pierre. (1964). Le structuralisme en psychopathologie: histoire, langage et relation. *Évolution Psychiatrique*, 29, 1, 85–129.
- Freud, Sigmund. (1900a). The interpretation of dreams. *SE*, 4–5.
- . (1950c [1895]). Project for a scientific psychology. *SE*, 1: 281–387.
- Freud, Sigmund, and Breuer, Josef. (1895d). *Studies on hysteria*. *SE*, 2.
- Green, André. (1963). La psychanalyse devant l’opposition de l’histoire et de la structure. *Critique*, 194, 649–662.
- Perron, Roger. (1981). Note sur la notion de structure. *Revue française de psychanalyse*, 45, 4, 1059–65.

### **Further Reading**

- Brenner, Charles. (2002). Conflict, compromise formation, and structural theory. *Psychoanalytic Quarterly*, 71, 397–418.
- Gillett, Eric. (1997). Revising Freud’s structural theory. *Psychoanalysis and Contemporary Thought*, 20, 471–500.

Van den Daele, L. (1994). Revision of the topographic and structural theories. *Psychoanalysis and Contemporary Thought*, 17, 407–446.

## STRUCTURALISM AND PSYCHOANALYSIS

Structuralism, a major current of thought in the second half of the twentieth century, developed in France from the 1960s onward in reaction to existentialism and humanism. From a methodological point of view, in the analysis and understanding of “objects” (especially those in the social sciences), it tended to see “structures” as pre-eminent and to see the given and its directly observable features as mere “effects.” [Ed: Quotes indicate jargon terms in structuralism.]

Arising from the linguistics of Ferdinand de Saussure and in particular from the Prague and Moscow schools, structuralism counts many representatives in various fields. There are the linguist Roman Jakobson, the socioethnologist Claude Lévi-Strauss, the philosopher and archeologist of knowledge Michel Foucault, the reinterpreter of Marxism Louis Althusser, the writers for the periodical *Tel Quel*, the literary critic Roland Barthes, and the psychoanalyst Jacques Lacan.

Gilles Deleuze, in his article “À quoi reconnaît-on le structuralisme?” (How to recognize structuralism; 1973), tried to enumerate “formal criteria” for recognizing what is structuralist, in particular, as they apply to the field of psychoanalysis. The criteria are the following:

- d) The symbolic, which proceeds from a rejection of the mere interplay of opposition and complementarity between the real and the imaginary (Lacan, 1974–1975). In Deleuze’s view, Freud can be interpreted on the basis of two principles: “the reality principle, with its force of disappointment, and the pleasure principle, with its power of hallucinatory satisfaction,” he writes. Carl Gustav Jung and Gaston Bachelard take the perspective of the “transcendent unity and borderline tension” of the two principles. The symbolic, a structure that has nothing to do with perceptible forms (gestalts and figures of the imagination) or with any intelligible essence, must be understood in Louis Althusser’s fashion, “as the production of an original and specific theoretical object.”
- e) Localization and positioning. Any element of a structure has neither extrinsic designation nor intrinsic meaning, and thus has only one sort of meaning, positional meaning (with no real extent nor imaginary extension). Thus, in genetic biology, “genes are part of a structure insofar as they are inseparable from ‘loci,’ places capable of changing their relations within the chromosome.” The real subjects or objects are thus not what “occupy the places,” since they are determined in a topological and relational way. In his *Écrits* (1966), Jacques Lacan defines intersubjectivity as a symbolic structural space, that of the signifier.
- f) The differential and the singular, which bring into play the positional units that are the symbolic elements of a structure. The phoneme shows this in an exemplary fashion, since it is a relationship that is neither a thing nor an imaginary, but a component of an elementary differentiation of two words with different meanings (“robbing” and “bobbing” differ by the phonemic relation of “r” and “b”). Singularities are assigned by the differential and produce structural particularities (as do names and attitudes for Lévi-Strauss). Lévi-Strauss uncovered “parentemes,” positional units that do not exist outside differential relations (brother/sister, husband/wife, father/mother, maternal uncle/sister’s son). Serge Leclair showed in “Counting with Psychoanalysis” that the “libidinal movements” of the body are linked to symbolic elements of the unconscious, “incarnating the singularities of structure in this place or that.”
- g) The differentiating element, the act of differentiation. “The structure is not actualized unless it differentiates itself in time and space,” and it does so by its actualization. “The two notions of multiple internal temporality and static ordinal genesis are, in this sense, inseparable from the interplay of structures,” Deleuze wrote.
- h) The serial, in other words, the necessary organization of symbolic elements in their differential relations by means of which a structure arranges itself into different developments that play on and through one another. For instance, a social structure is organized into series: economic, political, juridical, etc. An operative structure has at least two series; for instance, phonemes require the

second series of morphemes. In Lacan (1966), the unconscious “implies a development in two [variable] series,” as his commentaries on Edgar Allan Poe’s “The Purloined Letter” or Freud’s case of the Rat Man (1955a [1907–1908]) show.

- i) Finally, the empty square, which is the paradoxical element of structure. It can never be filled without being disabled. This singular object  $x$  “is the point of convergence of the divergent series as such.” It is the “handkerchief” referred to by André Green (an associate of Lacan) in his essay “Othello” (1969), which runs through all the series in the play. The empty square is the guarantor and representative of the third party, “which intervenes essentially in the symbolic system.” The object is always displaced in relation to itself, “missing from its own place” according to Lacan, without being distinguished from that place, adds Deleuze.

From Deleuze’s article, it is thus clear that structuralism claims that the determinants of reality and those of the imaginary are essentially unconscious structures, because they are in every place and at every time “covered over by their products and their effects.” From this viewpoint, one can regard the second Freudian topography of the psychic apparatus as already a structuralist representation of the psyche, since even consciousness, on the plane of the ego, is an effect of the interplay of different agencies: the id, the ego itself in its different characters, and the super-ego. By way of contrast, Jean Piaget, in his article “La psychologie” (Psychology; 1972), characterizes psychoanalysis as a “complete reductionism” insofar as it seeks, in his view, to reach mental processes by means of “the direct study of the contents of representations and affects” and does not recognize any autonomy of the ego (Heinz Hartmann) “free of sexual conflicts.”

It was Jacques Lacan who radically located psychoanalysis within the domain of structuralism. At the beginning of the twenty-first century we are witnessing a return of the subject, which existentialism, for one, refused to abandon. But because it is difficult to see how an autonomous subject, independent of structure, can again be affirmed without returning to ego psychology or existential psychoanalysis (the most traditional rationalism), there does not seem as yet to be any alternative to structuralism.

DOMINIQUE AUFFRET

*See also:* Formations of the unconscious; Four discourses; France; Model; Monism; Name-of-the-Father; Object  $a$ ; Nonverbal communication; Parade of signifiers; Signifier; Signifier/signified; Structural theories; Symbolic, the (Lacan).

### Bibliography

- Deleuze, Gilles. (1973). À quoi reconnaît-on le structuralisme? In François Châtelet (Ed.), *Histoire de la philosophie, idées, doctrines, le XXe siècle*. (pp. 299–335) Paris: Hachette.
- Foucault, Michel. (1973). *The order of things: An archaeology of the human sciences*. New York: Vintage Books. (Original work published 1966)
- Green, André. (1969). Othello, une tragédie de la conversion: Magie noire et magie blanche. In his *Un oeil en trop: le complexe d'Oedipe dans la tragédie*. (pp. 109–164) Paris: Éditions de Minuit.
- Jakobson, Roman. (1963). *Essais de linguistique générale*. Paris: Minuit.
- Lacan, Jacques. (1966). *Écrits*. Paris: Seuil.
- . (1974–1975). *Le séminaire: Livre XXII, R.S.I. Ornicar?*, 2–5.
- Lévi-Strauss, Claude. (1963). *Structural anthropology* (Claire Jacobson and Brooke Grundfest Schoepf, Trans.). New York: Basic Books. (Original work published 1949)
- Piaget, Jean. (1972). La psychologie. In his *Épistémologie des sciences de l'homme* (pp. 133–250). Paris: Gallimard.

---

## STUDIENAUSGABE

The *Studienausgabe*, a critical edition of Freud’s work comprised of ten numbered volumes and a supplementary volume (*Ergänzungsband*), is the sole German-language edition offering a broad selection of the writings accompanied by an impressive scholarly apparatus.

Edited by Alexander Mitscherlich, Angela Richards, and James Strachey, Volumes 1–10 were published by S. Fischer Verlag between 1969 and 1975. The supplement (*Schriften zur Behandlungstechnik*), co-edited by Ilse Grubrich-Simitis, which added Freud’s writings on psychoanalytic technique, appeared in 1975. On the fiftieth anniversary of Freud’s death, in 1989, the *Studienausgabe* were reissued in an updated and revised version. Simultaneously, the *Sigmund Freud—Konkordanz und Gesamtbibliographie*, originally compiled by Ingeborg Meyer-Palmedo and already associated with the



*Studienausgabe* in 1975, was radically reworked, with the assistance of Gerhard Fichtner, and published under the title *Freud-Bibliographie mit Werkkonkordanz* as a companion to the revised *Studienausgabe*. (A new, corrected edition of the *Freud-Bibliographie* appeared in 1999.)

The ten volumes of the *Studienausgabe* are arranged thematically. Some contain a single work, as in the case of Volume 1, the *Introductory Lectures on Psycho-Analysis*, or Volume 2, *The Interpretation of Dreams*, while those which collect several texts on a single subject are arranged chronologically. The editorial commentary consists essentially, with a few additions, of a translation of James Strachey's critical apparatus for the *Standard Edition*. Strachey, who had participated actively in the planning of the *Studienausgabe*, died in 1967, so it fell to his collaborator Angela Richards to undertake the better part of the editing, with constant assistance from Ilse Grubrich-Simitis and Ingeborg Meyer-Palmedo.

All volumes of the *Studienausgabe* are supplied with substantial bibliographies and detailed indexes to help researchers, teachers, and students. Freud's numerous revisions in successive editions of his writings, especially in such major works as *The Interpretation of Dreams* or the *Three Essays on the Theory of Sexuality*, are clearly identified and dated. More than two-thirds of the Freudian texts assembled in the *Standard Edition* are to be found in the *Studienausgabe*.

When Freud went into exile in London in 1938, his projects with respect to publishing his work went with him. James Strachey and his group of collaborators then proceeded to build up an editorial culture around their projected *Standard Edition* which had no equivalent in Austria or in the Federal Republic of Germany of the 1960s. The paradoxical result is that the first, and up to now the only critical edition of Freud's work in German relies for the most part on the work of English-speaking editors.

In conclusion, it may be fairly said that after the brutal stop put by the Nazis to the influence of Freud's work in the German-speaking countries, the *Studienausgabe* have effectively promoted it, not only among specialists but also among general readers.

ILSE GRUBRICH-SIMITIS

See also: *Gesammelte Werke*; *Standard Edition of the Complete Psychological Works of Sigmund Freud*.

## Bibliography

Grubrich-Simitis, Ilse. (1996 [1993]). *Back to Freud's texts. Making silent documents speak*. New Haven and London: Yale University Press.

———. (1989). Nachtrag 1989 zu den "erläuterungen zur edition." *Studienausgabe* (Vol. 1, p. 32). Frankfurt-am-Main: Fischer.

Richards, Angela. (1969). Erläuterungen zur edition. *Studienausgabe* (Vol. 1, pp. 27–32). Frankfurt-am-Main: Fischer.

---

## STUDIES ON HYSTERIA

Beginning in 1892, Sigmund Freud gradually abandoned the technique of hypnosis and began using the "method of cathartic abreaction" that had been described to him by his older colleague, Josef Breuer, ten years earlier. He became increasingly convinced of the sexual origin of neurotic disturbances in his patients and, uneasy over the work Pierre Janet had begun to publish (*L'État mental des hystériques*, 1892–1894), convinced Breuer to join him in writing a book that, by situating the origin of their research in 1881, would assure them of priority in the world of scientific research.

A letter to Wilhelm Fliess on June 28, 1892, referred to Breuer's agreement. The two authors were going to contribute jointly to the volume. In the autumn of that year Freud began testing his new techniques of concentration on the symptom and placement of his hands on the forehead in an attempt to draw out Elisabeth von R.'s forgotten pathogenic memories, and by December he and Breuer had signed a "Preliminary Communication" that appeared in January 1893 (1893a). They attributed the cause of hysterical symptoms to the forgotten memory of a trigger incident that had not been "abreacted" and acted on the psyche as if it were a foreign body. The symptoms disappeared whenever the memory and its affect were awakened by providing them with a verbal outlet, which led to the famous maxim that "hysterics suffer primarily from reminiscences" (1895d, p. 7). For his part, Breuer insisted on the "tendency to a dissociation of consciousness" (1892–93a, p. 122) caused by daydreams. The "Preliminary Communication" aroused considerable interest in the international scientific community, as shown by a reference from Frederick W. H. Myers in Great Britain, only three months after its appearance.

However, the theory of sexual etiology began to appear increasingly convincing to Freud, which

created a rift with the reticent Breuer. An 1894 article on the “Psychoneuroses of Defense” (1894a) enabled Freud to distinguish his theory from that of Pierre Janet and describe the concept of “conversion.” At the same time he began to take an interest in dreams and, having written down his observations, in the spring of 1895 he wrote the preface and final chapter of *Studies on Hysteria*—during a period when he was still experiencing the disastrous consequences of Wilhelm Fliess’s operation on Emma Eckstein.

The book appeared in May. The first chapter incorporated the “Preliminary Communication.” The second was devoted to the case studies: Anna O., who was Breuer’s patient, followed by “observations that read like novels and do not bear the stamp of seriousness typical of scientific writings.” These were written by Freud and described his treatment of Emmy von N., Lucy R., Katharina, and Elisabeth von R. (and Frau Cäcilie M., to whom reference is made throughout the book).

A third chapter by Breuer is devoted to theoretical issues. Here he describes the ideogenous nature of hysterical disturbances, the “unconscious or subconscious representations” of a primitive trauma that is primarily associated with sexual matters, and the recognition of mental hyperactivity in hysterics—the same individuals in whom Janet had found a “weakness,” if not a constitutional mental inadequacy. He insisted on the presence of “hypnoidia” and the constancy of hypnoid states.

Freud wrote the last chapter, “The Psychotherapy of Hysteria.” In it he describes the overdetermination of symptoms and the value of the cathartic method. The preliminary structure of what will become psychoanalysis is laid out: the patient on the couch, free association, the consideration of “false connections,” and the disjunction *mésalliance*, which is the transference to the doctor of “the distressing ideas which arise from the content of the analysis” (1895d, p. 302). For Freud the psychic materials of hysteria appear to be arranged in strata, starting from a kernel of traumatic memories. This arrangement can be chronological—in which case, Freud writes, “it [is] as though we were examining a dossier that had been kept in good order” (p. 288)—or thematic, such themes being “stratified concentrically round the pathogenic nucleus” (p. 289). The goal of the analysis is to “penetrate . . . to the nucleus of the pathogenic organization” (p. 295), an operation that requires considerable effort on the part

of the therapist, who must overcome the patient’s resistance in order to unearth the buried memory that is the source of the problem. The means used to overcome this were still rudimentary, gentle, physical pressure applied to the points of the forehead, and an increasing barrage of questions intended to “extort” a patient’s secrets. Even though the method was claimed to be successful, Freud concluded, “No doubt fate would find it easier than I do to relieve you of your illness. But you will be able to convince yourself that much will be gained if we succeed in transforming your hysterical misery into common unhappiness. With a mental life that has been restored to health you will be better armed against that unhappiness” (p. 305).

By the following October, Freud would publicly abandon Breuer’s theory of hypnoid states and affirm that hysteria arises from seduction early in life, a “pre-sexual sexual fright” (letter to Fliess, October 15, 1895).

But the book went out into the world and Freud, already known for his neurological work, became recognized as a “psychologist.” Although Adolf Trümpell sharply criticized the book (letter to Fliess, February 6, 1896), an event that deeply affected Breuer, Havelock Ellis praised it, as did Théodore Flournoy and a number of French authors. Eugen Bleuler himself wrote, in 1896, that it was “one of the most important recent additions to the field of normal and pathological psychology.” The success of the *Studies on Hysteria* did come at a price, however. For a number of years the book was considered, by those who did not have access to Freud’s later writings, to contain the essence of his theory and practice. Even Pierre Janet, in his critiques of psychoanalysis in 1907 and 1913, did not appear to look any deeper for an understanding of Freudian theory.

Although Sándor Ferenczi, in a letter to Freud on March 2, 1909, described it as the “germ of everything we now know,” Freud had mixed feelings about the book and struggled against the ongoing references to theories he believed to be outdated. As early as 1901 he wrote, “Ever since we wrote the *Studies*, psychoanalytic technique has undergone a fundamental transformation. The work had symptoms as its point of departure and their successive resolution as its goal. Since then I have abandoned this technique, for I found it unsuited to the delicate structure of the neurosis.” Freud even minimized his contribution to the book in his *On the*

*History of the Psycho-Analytic Movement* (1914d) and especially in *An Autobiographical Study*: “As regards the theory put forward in the book, I was partly responsible, but to an extent which it is to-day no longer possible to determine. That theory was in any case unpretentious and hardly went beyond the direct description of the observations. It did not seek to establish the nature of hysteria but merely to throw light upon the origin of its symptoms. . . . The theory of catharsis had not much to say on the subject of sexuality. In the case histories which I contributed to the *Studies* sexual factors played a certain part, but scarcely more attention was paid to them than to other emotional excitations. . . . It would have been difficult to guess from the *Studies on Hysteria* what an importance sexuality has in the aetiology of the neuroses” (1925d, p. 22). Freud did not include the book in the first edition of his collected works, the *Gesammelte Schriften*.

In 1925 Freud added, “The practical results of the cathartic procedure were excellent. Its defects, which became evident later, were those of all forms of hypnotic treatment. There are still a number of psychotherapists who have not gone beyond catharsis as Breuer understood it and who still speak in its favor” (p. 22).

At a time when psychoanalytic practice, for reasons of pseudo-efficiency, risks incorporating psychotherapeutic techniques dating from before the *Studies on Hysteria*, the study of this key work is more relevant than ever. This is undeniably important, if only to situate its ideas as a historical step, simple but important, in the trajectory that would lead Freud, over the next ten years, to modify his theory and practice, thereby defining the framework of psychoanalytic therapy as it has come to be known.

ALAIN DE MIJOLLA

See also: Cathartic method.

### Source Citation

Freud, Sigmund, and Breuer, Josef. (1895d). *Studien über hysterie*. Vienna; GW, 1, 75–312; *Studies on hysteria*. SE, 2.

### Bibliography

Ellenberger, Henri F. (1970). *The discovery of the unconscious: The history and evolution of dynamic psychiatry*. New York: Basic Books.

Freud, Sigmund. (1893a). On the psychical mechanism of hysterical phenomena: preliminary communication. SE, 2: 1–17.

———. (1914d). On the history of the psycho-analytic movement. SE, 14: 1–66.

———. (1925d). An autobiographical study. SE, 20: 1–74.

Freud, Sigmund, and Breuer, Josef. (1950a [1887–1902]). Extracts from the Fliess papers. SE, 1: 173–280.

Ellenberger, Henri F. (1970). *The discovery of the unconscious: The history and evolution of dynamic psychiatry*. New York: Basic Books.

Grubrich-Simitis, Ilse. (1995). *Urbuch der psychoanalyse. Hundert jahre studien über hysterie von Josef Breuer und Sigmund Freud*. Frankfurt am Main: S. Fischer.

---

## SUBCONSCIOUS

A term that appears rather frequently in the psychological literature of the late 19th century, especially in France, the “subconscious” was used to designate a mental state that is subliminal, diminished, or weak and obscure; in terms of conscious thought it implied a difference a degree not of kind. “Judgment and reasoning, whether conscious, subconscious, or unconscious, remain the same, except for a difference in the degree of clarity of the representation,” wrote Théodule Ribot in *La Logique des sentiments* (1905, p. 80).

The subconscious was most clearly delineated in the work of Pierre Janet. In *Automatisme psychologique* (1889), he posited two contrasting forms of mental activity, automatism and synthesis. The former corresponded to the primal and archaic; the latter, to creativity and higher levels of consciousness. On the basis of experimental work with hysterics, Janet demonstrated that in morbid states, due to a diminished field of consciousness, automatism took precedence over the activity of synthesis.

Janet essentially identified the subconscious with psychic automatism and, in hysteria, he hypothesized profound dissociation and splitting of the personality. He was influenced by the work of Frederick Myers, the British psychical researcher, and the work of American physician Morton Prince on dual and multiple personalities; he also took into account earlier investigations by Jean-Jacques Moreau de Tours on hashish intoxication.

In his early writings, including *Studies on Hysteria* (1895d), Sigmund Freud used “subconscious” as more

or less equivalent to “unconscious” but he soon abandoned the former and disapproved of usage that conflated the two terms. He characterized the unconscious as actively associated with intrapsychic conflict while viewing Janet’s subconscious as passive and associated with psychological and physiological weakness. To Janet’s “dissociation” he opposed the concept of repression and the psychological duality of separate domains of conscious and unconscious mental functioning.

ANNICK OHAYON

*See also:* Flournoy, Théodore; France; Great Britain; Janet, Pierre.

### **Bibliography**

Freud, Sigmund, and Breuer, Josef. (1895d). Studies on hysteria. *SE*, 2.

Janet, Pierre. (1889). *L'Automatisme psychologique: essai de psychologie expérimentale sur les formes inférieures de la vie mentale* (thesis). Paris: Felix Alcan.

———. (1937). Les troubles de la personnalité sociale. *Annales médico-psychologiques*.

Ribot, Théodule. (1905). *La logique des sentiments*. Paris: Alcan.

---

## **SUBJECT**

Unable to separate the term *subject* from the notion of consciousness, Freud placed it in opposition to the external world or the object, or in their reciprocal reversal (1915e). In “New Introductory Lectures on Psycho-Analysis” (1933a [1932]) Freud said the ego was “in its proper sense a subject” (p. 58)—not as an essence, but a function to be filled.

Jacques Lacan (1966) changed this by referring to the subject as “the subject of the unconscious” in its “unwitting” dimension, its ex-centricity in relation to itself. The subject is the “it” that the “I” speaks of when the I wishes to refer to itself as unconscious. Or rather, the subject is this very split between the “I” and the “it.” The ego, for its part, is not the “I”: a precipitate of identifications, it becomes the locus of misapprehension. How, then, is it possible for “the subject to recognize and name his desire”? The answer is that the truth speaks, even if the words spoken convey both the lie of desire and its truth, and even if “the I that speaks is not the same as the I that is spoken.”

The Other gives language its sense and the subject is an effect of that sense. The subject of the unconscious is “the subject represented by a signifier for another signifier,” and the only important thing is the degree of difference between the two signifiers. The Imaginary also enters into its determination through that which is imagined about the object *a*, the only object that can be transferred for transference into the place occupied by phallic lack. Thus, “the truth that the I of the unconscious tells us is that only this nothingness sustains it.”

Accordingly, for Lacan, the aim of treatment was not to fill this gaping nothingness, but to manifest it and potentially to express it through sublimation . . . or by training psychoanalysts. He emphasized that the kind of listening that took place in analysis often took wrong turns, and thus attempted, in his last years, to reequilibrate his system, notably by using the topological figure of the Borromean knot, to give “consistency” to the Real, the Symbolic, and the Imaginary: “The subject is what is determined by the figure in question: Not that he is in any sense its double, the subject is conditioned by the points at which the knot catches and tightens in these points.”

The Lacanian subject is thus very different from the one based on Freudian metapsychology. Lacan’s approach upends the theory of subjectivity by making the subject the subject of the drives, who sometimes directs them and at times is directed by them.

This subject is alien to itself, split between the Self and itself, though there is a constant reciprocity of relations between the mind’s agencies, and reversibility of the economic and dynamic transformations within the personality as a whole. Among the various modalities of representance, representation appears as the bridge or articulation between the economic dimension and that of meaning, the product of work whose conscious or unconscious quality constitutes modalities that are more or less contingent or necessary, depending on the case, within the figure of tension that is desire.

If, for Freud, the lifting of repression produced conscious awareness, today the emphasis has shifted onto whether or not a new, “subjectivable” meaning can possibly emerge, be assumed by the subject, and through the effects of deferred action [*après coup*] that constitute psychic reality, itself become a function of both internal constraints and effects of the psychic

reality of the object. Piera Aulagnier's "I," the study of the originating conditions of the process of subjectification (Cahn), and the related *Aufhebung* (sublation, supersession) illuminated by the notion of transitionality (Roussillon) are new approaches centered on the internal and external elements at stake in the splittings and exclusions that oppose this subjective appropriation. Here, in contrast to the problematics of neurosis, where the work of analysis naturally predominates, it is the work of the analyst that is revealed to be determinant, to contain that work, absorb it, and connect its productions.

RAYMOND CAHN

*See also:* Alienation; Ego; Ego (analytical psychology); Ego (ego psychology); I; Identity; Imaginary identification/symbolic identification; Individual; Individuation (analytical psychology); Object; Object *a*; Other, the; Phenomenology and psychoanalysis; Philosophy and psychoanalysis; Self; Self-consciousness; Subject of the unconscious; Want of being/lack of being.

### **Bibliography**

- Aulagnier, Piera. (2001). *The violence of interpretation: From pictogram to statement* (Alan Sheridan, Trans.). Hove, East Sussex, and Philadelphia: Brunner Routledge. (Original work published 1975)
- Cahn, Raymond. (1991). Du sujet. *Revue française de psychanalyse* 55, 5–6, 1371–1490.
- Freud, Sigmund. (1915e). The unconscious. *SE*, 14: 159–204.
- . (1933a [1932]). New introductory lectures on psycho-analysis. *SE*, 22: 1–182.
- . (1940a). An outline of psycho-analysis. *SE*, 23: 139–207.
- Lacan, Jacques. (1977). *Écrits: A selection* (Alan Sheridan, Trans.). New York: Norton. (Original work published 1966).
- Roussillon, René. (1995). La métapsychologie des processus et la transitionnalité. *Revue française de psychanalyse*, LIX.

### **Further Reading**

- Ogden, Thomas. (1994). *Subjects of analysis*. Northvale, NJ: Aronson, Inc.
- Renik, Owen. (1998). The analyst's subjectivity and the analyst's objectivity. *International Journal of Psychoanalysis*, 79, 487–498.

Smith, Henry. (1999). Subjectivity and objectivity in analytic listening. *Journal of the American Psychoanalytic Association*, 47, 465–484.

## **SUBJECT OF THE DRIVE**

In his seminar on *The Four Fundamental Concepts of Psychoanalysis* (1964), Jacques Lacan reread Freud's essay "Drives and their Vicissitudes" (1915c) in order to emphasize that the four components of the drive—pressure, object, aim, and source—are not natural phenomena: the drive is a montage.

The constancy of the drive's pressure differentiates it from vital needs, which vary according to their own rhythms (Lacan, p. 171). Thus hunger is not the same as the oral drive. Satisfaction does not consist in fulfilling a need, but in completing a circuit of three stages. The "mouth that is involved in the drive," Lacan stated, "is not satisfied by food" (p. 167). The drive begins at an erogenous zone, and then makes a circuit around the object cause of desire, the object *a*. Thus Lacan saw drives as distinct from vital needs.

Lacan reserved the term "drive" for the sexual drives. Instincts of self-preservation—the *Ichtriebe*, Freud's ego-drives—were a function of narcissism. The subject of the drive emerged once the three stages of the drive's circuit were completed. Along with the active and reflexive stages, Lacan emphasized the importance of a third stage, in which, as Freud had said, a new subject would appear. This new subject is an other. When the "I" is, like an object, subjected to this other, it may experience pain and become a subject itself. It will seek to attach itself to the enjoyment of this other, which from then on plays the role of real Other. Only by completing the circuit of the drive does the subject come into contact with the dimension of the Other as the treasure trove of the signifiers. For Lacan, the concept of the drive is the pivot between the body, enjoyment, and language.

Clinical work allows us to see infantile autism as the result of a failure at the third stage in the circuit of the drive.

MARIE-CHRISTINE LAZNIK

*See also:* Castration of the subject; Demand; Drive; Erotogenicity; Fantasy, formula of; Jouissance (Lacan); Perceptual identity; Real, the (Lacan); Subject; Topology.

### Bibliography

- Lacan, Jacques. (1978). *The four fundamental concepts of psychoanalysis* (Alan Sheridan, Trans.). New York: W. W. Norton. (Original work published 1964)
- Laznik, Marie-Christine. (1993). Pour une théorie lacanienne des pulsions. *Le Discours psychanalytique, revue de l'Association freudienne*, 10
- Penot, Bernard. (1998). La passion du sujet entre pulsion et signifiante. *Bulletin de la Société de psychanalyse de Paris*, 51.

### Further Reading

- Kernberg, Otto. (2001). Object relations, affects, and drives: Toward a new synthesis. *Psychoanalytical Inquiry*, 21, 604–619.

---

## SUBJECT OF THE UNCONSCIOUS

It has often been remarked that Freud hardly ever made use of the term “subject.” The only exception (which is surprising, because it was never noticed) was his respected use of the term in “Instincts and Their Vicissitudes” (1915c). While describing the normal instinctual “vicissitude,” where the drives turn back on the subject’s body and where the mode of satisfaction is reversed from active to passive, Freud wrote of “a new subject,” which he situated outside of the person proper. This subject wants to be watched (or violated) to satisfy the infantile need to be looked at (or treated sadistically). Freud thought that this instinctual subject-agent had been created at the stage where goals became passive—an idea that he took up again four years later with regard to the origin of the fantasy of “A Child is Being Beaten” (1919e). There he declared that the fantasy acquired its full subjective power only when it was being lived through passively: “I am beaten by the father.”

Subsequently, when Freud considered the love-hate dyad, he did not think of it as in the same category as instinctual dyads like the sadomasochistic and voyeur-exhibitionistic dyads. Instead, he conceived of it as being determined by narcissism. Then he returned to his former conception of an “ego-subject” after seeming to introduce the notion of an unconscious instinctual object in the first part of his study (Freud, 1915c).

Jacques Lacan took up the challenge of developing this concept of the subject of the unconscious in his

teaching. From 1945 on, he worked on defining the different meanings of the term “subject.” He wrote of the Cartesian subject of certainty, the negated subject of science, the personal subject of self-affirmation, and of course the two subjects of a sentence: the grammatical subject and the intentional subject. This duplication is at the basis of his conception of the intrinsically divided subject,  $\$$  (barred S), which accounts for his famous definition of the subject as being whatever a signifier represents for another signifier (Lacan, 1966/2002).

But Lacan was always led back to the “subject of unconscious desire”: the subject of the desires of *The Interpretation of Dreams*, the subject of the witticism and other expressions of the unconscious, which he saw as structured like a “language.” However, having reduced the subject of human desire to an effect of language (“the speaking being”), he didn’t reduce it any further to a grammatical subject. His subject was either instinctual or empty (like the word).

This drive-based vision of the subject prompted Lacan, in his first seminars (1975, 1978), to differentiate it categorically from the ego. On this point he broke openly with Freud’s notion of the global ego. In effect, he saw the ego as an imaginary function whose purpose is to provide the person with a sense of corporeal unity and continuity. Lacan emphasized that the ego was necessarily involved in a struggle against the instinctual registers, and this stance caused him to view the ego, as it reflects the image of the Other, as opposed to the subject (S), which emerges as the id. His interpretation of Freud’s famous statement “Wo Es war, soll Ich werden” (“Where the id was, there I should come to be”) led him to play on the homophony of “S” and “Es.”

Lacan viewed the newborn subject, because it was always born prematurely, as implicated in the “demands” through which it makes known its needs. It borrows these demands from the maternal signifying code. In so doing, the subject makes a first effort to attach itself (instinctively) to a desiring maternal Other, thus confirming the incompleteness of the latter. When the young subject observes the lack in the Other, it will disengage from its mother. Lacan said that the signifier of the Other’s lack showed how “all the other signifiers represent the subject,” but on the other hand he conjectured that “when this signifier is missing, all the other signifiers represent nothing” and no one (1977, p. 316).

The subject, in its fantasies, is able to represent itself as maintaining a desire through the partial (real) objects that Lacan called “little *a*’s.” These little *a*’s are residues of the operation through which the first Other recognizes itself as being subject to the rules of symbolic exchange.

The neurotic in analysis obstinately refuses to imagine the Other as a subject, “the subject who is supposed to know,” and refuses to accept that the Other is animated by a desire toward him. This is what sparks the transference in the cure.

BERNARD PENOT

*See also:* Fantasy, formula of; Linguistics and psychoanalysis; Signifier; Signifying chain; Topology; Unary trait.

### **Bibliography**

Freud, Sigmund. (1915c). Instincts and their vicissitudes. *SE*, 14: 109–140.

Lacan, Jacques. (1988). *The seminar of Jacques Lacan. Book 1: Freud's papers on technique (1953–1954)* (John Forrester, Trans.). (Original work published 1975)

———. (1988). *The seminar of Jacques Lacan. Book 2: The ego in Freud's theory and in the technique of psychoanalysis (1954–1955)* (Sylvana Tomaselli, Trans.). (Original work published 1978)

———. (2002). The subversion of the subject and dialectic of desire in the Freudian unconscious. In his *Écrits: A selection* (Bruce Fink, Trans.). New York: W. W. Norton. (Original work published 1960)

---

## **SUBJECT'S CASTRATION**

Lacanian notions of castration are linked to frustration and deprivation, lacking and giving, and ultimately to object relations. These represent a certain culmination of the history of psychoanalytic thought on the subject. To better define their importance, let us examine their history.

Starting in 1905, Freud posited a theory of object relations that would be linked to the stages of libidinal development (Freud, 1905d). He later proposed that the loss of feces should be considered as the precursor of the castration complex (Freud, 1916–1917e). Thus the Freudian concept is “absolutely realist.”

It fell to August Stärke, in a long and important article published in 1921, to expand this theory by

proposing that the breast no longer be considered the first lost object and the model for castration anxiety. Instead he recommended that masochistic pleasure also be connected with castration anxiety, which is expressed as a desire to receive the penis.

In 1928, building on theories advanced by Karl Abraham in 1924 and on thoughts that Freud expressed in 1926 about the peculiarities of the castration complex in the woman (Freud, 1926d), Melanie Klein differentiated between early anxiety in boys and girls. A boy's anxiety involves castration and a girl's the good internal functioning of her body.

Thus there is a continuous strand of Freudian thought that considers the object as tangible and castration as a reality. Even an author like Bion did not depart from this line (Bion, 1959). For him, links and attacks, the breast and the penis, are always quite real—even if their reality is only fantasmatic.

Jacques Lacan revolutionized this tradition. For him, castration fundamentally pertains to the subjectivity of the subject. It derives from a symbolic debt, linked to the prohibition against incest and murder. In the real, the subject observes that a woman lacks a penis. Thus the relation to an object is just as much a relation to the lack of an object, the object existing just as much by its absence as by its presence.

Lacan claimed that the necessity of this revolution was justified by what had become the “heteroclit nature of the castration complex” (Lacan, 2002, p. 306). He suggested this in the complete form of his graph of desire, where we find the unconscious and the Other on the one hand and the barred subject on the other. Then, successively, there are the signifier and the voice and then *jouissance* and castration related to “the drive as the treasure trove of signifiers” (p. 302). Castration means, “that *jouissance* has to be refused in order to be attained on the inverse scale of the law of desire” (p. 311).

For both sexes, the phallus is “the signifier destined to designate meaning effects as a whole” (p. 275) and “the signifier of the Other's desire” (p. 279). As such, castration is not directly related to the reality of the penis. In fact, this relation is problematic and requires several operations: “It is thus that the erectile organ—not as itself, or even as an image, but as a part that is missing in the desired image—comes to symbolize the place of *jouissance*,” that is, as “the function of a missing signifier: (–1)” (p. 307). “The shift of (–/)

(lowercase phi) as phallic image from one side to the other of the equation between the imaginary and the symbolic renders it positive in any case, even if it fills a lack. Although it props up (−1) it becomes Φ (capital phi) there, the symbolic phallus that cannot be negated, the signifier of jouissance” (p. 308). The castration complex is “incited” by the object (−/) that designates it in its imaginary function.

The Lacanian revolution corresponds to a complete separation of dialectic from intersubjectivity, the very kernel of Freudian thought. This dialectic is expressed in the schema RSI, which represents the real, the symbolic, and the imaginary. Castration is inscribed therein as related to frustration and deprivation, as Lacan showed in his seminar on object relations (Lacan, 1956–57).

LUIZ EDUARDO PRADO DE OLIVEIRA

*See also:* Castration complex; Disavowal; Fantasy, formula of; Graph of Desire; Object *a*; Other, the; Phallus; Real, the (Lacan); Real, imaginary, and symbolic father; Sexuation, formulas of; Topology; Want of being/lack of being.

### **Bibliography**

- Bion, Wilfred R. (1959). Attacks on linking. *International Journal of Psycho-Analysis*, 40, 5–6, 308–315.
- Lacan, Jacques. (1994). *Le séminaire-livre IV, (1956–57), La relation d'objet*. Paris: Le Seuil.
- . (2002). *Écrits: A selection*. (Bruce Fink, Trans.) New York: W. W. Norton.
- Siboni, Jacques. (1996). *Les mathèmes de Lacan: anthologie des assertions entièrement transmissibles et de leurs relations dans les écrits de Jacques Lacan*. Paris: Lysimaque.
- Stärcke, August. (1921). The castration complex. *International Journal of Psycho-Analysis*, 2, 2, 179–201.

### **Further Reading**

- Rangell, Leo. (1991). Castration. *Journal of the American Psychoanalytic Association*, 39, 3–24.

---

## **SUBJECT'S DESIRE**

Although it was introduced into French by Ignace Meyerson's inaccurate translation of the Freudian term *Wunsch* (wish), desire went on to become a

major Lacanian concept. For Lacan as well as for Freud, desire is the subject's yearning for a fundamentally lost object. Thus for Freud, any search for an object is, in fact, an attempt to refind it. For Lacan, however, the object of desire is located prior to desire and functions as its cause.

Lacan subverted the Freudian aphorism that “a dream is the fulfillment of a wish” (Freud, 1900a, p. 121): “If Freud accepts, as the reason for a dream that seems to run counter to his thesis, the very desire to contradict him on the part of a subject whom he had tried to convince of his theory, how could he fail to accept the same reason for himself when the law he arrived at is supposed to have come to him from other people?” (Lacan, *Écrits*, p. 58). Moreover, in what Freud called the rebus-like structure of the dream, Lacan found support for assimilating condensation (*Verdichtung*) and displacement (*Verschiebung*) to the tropes of metaphor and metonymy. Thus he was able to conclude that “the unconscious is structured like a language.”

Freud used dreams to derive both his first topography and a model of the psychic apparatus that defined desire as the “cathexis” of a mnemonic image linked to the satisfaction of need. Thus for Freud desire is satisfied just once, and any subsequent manifestation of desire is only an impulse (*Regung*) that aims to reestablish, sometimes to the point of (psychotic) hallucination, the image of an irretrievably lost object. This is the “empirical” failure of hallucinatory satisfaction that leads to thought—which, Freud says, “is nothing but a substitute for a hallucinatory wish” (p. 567)—and thus to voluntary activity that aims at the satisfaction of need, not desire.

Dreams, which realize desires in the quick, “backward” way, serve as an example of the psychical apparatus's primary mode of functioning, abandoned because of its inefficacy. Censorship, the guarantor of our mental health, prevents the impulses of unconscious desire from being manifested during the day. Symptoms must be considered as the realization of wholly unconscious desires. Dreams, on the other hand, express the attainment of these desires with the consent and control of the preconscious, which tilts in the end toward the desire to sleep.

On the basis of the “burning child dream” (Freud, pp. 509–511), which expressed this desire to sleep, Lacan constructed his graph of desire (Lacan, 1958–59,



session of December 10, 1958). The sentence of the dreamer, “His father was dead,” is situated at the lower level, that of the statement. At the upper level, that of the enunciation, Lacan placed the sentence, “He did not know it.” And finally, it is between the statement and the enunciation that Lacan inserted Freud’s interpretation, that is, the desire of the dreamer: “according to his wish.” The sentence “He did not know it” showed the way in which the dreamer protected the paternal function, which he was deprived of by the death of the real father, and that was the origin of the dream. The desire of the dream was to throw a veil of perpetual ignorance over oedipal desire.

At the intersection of the imaginary and the symbolic, human desire is established by a loss that can be symbolized by the separation from the placenta at birth. This primal castration gives birth to the subject of an impossible enjoyment sustained by the object *a*. Later losses, which constitute the possible objects of human desire (the nipple, feces, the phallus), are always manifested more or less by the anxiety that indicates the reappearance of this lost primal enjoyment, that is, the lack of lack. That is why the speaking being can only “symbolize” this lack by the minus phi ( $-/$ ), which is the image of the capital phi,  $\Phi$ . Likewise, this lack can only be “imagined” in the articulation of the fantasy,  $\$ \diamond a$ , in which the barred S is the subject and the symbol  $\diamond$  means “desire of.” This is the form that is best suited to defending against the desire of the Other.

This desire “is neither the appetite for satisfaction [Need] nor the demand for love [Demand], but the difference that results from the subtraction of the first from the second” (Lacan, *Écrits*, p 276). It protects the subject from the enjoyment of the Other by means of the forms that its object takes. In phobia the object is prohibited; in hysteria it is unsatisfying; and in obsession it is merely defended against. In any case, desire remains marked by—and serves as a reminder of—a lost enjoyment. The object of this enjoyment, the phallus, becomes the signifier of the very lack of a signifier, and thus the signifier of castration as imposed by language. And so the object of desire is always a metonymic object, always a desire for “something else.”

This Lacanian rereading remains oddly in agreement with Freud on the basis of the analogy that Lacan establishes between desire and dream, and it raises the question of the place of language in their theory. If language for Freud is a kind of superstruc-

ture linked to the life instinct, and thus an ideal to be attained, for Lacan it is also the insurmountable limit and metaphor of being.

PATRICK DELAROCHE

*See also:* Fantasy; Formations of the unconscious; Graph of Desire; Wish-fulfillment; Wish/yearning.

### Bibliography

- Dor, Joël. (1997). *Introduction to the reading of Lacan: The unconscious structured like a language*. (Judith Feher Gurewich, Ed., in collaboration with Susan Fairfield). Northvale, NJ: J. Aronson. (Original work published 1985–1992)
- Freud, Sigmund. (1900a). The interpretation of dreams. *SE*, 4–5.
- Lacan, Jacques. (2002). *Écrits: A selection*. (Bruce Fink, Trans.) New York: W. W. Norton.
- . (1958–59). *Le séminaire-livre VI, le désir et son interprétation*, unpublished.
- Sédot, Jacques (Ed). (1980). *Retour à Lacan?* Paris: Fayard.

---

## SUBLIMATION

Sublimation is a process that diverts the flow of instinctual energy from its immediate sexual aim and subordinates it to cultural endeavors.

The idea of sublimation leads back at once to the alchemical metaphor of the transmutation of base metal into gold, and to aesthetics, which from the ancient world (Longinus) to Romanticism (Goethe) saw the sublime as the transcendence of the individual’s limitations. The concept evolved in Freud’s work from the idea of the ennoblement or embellishment of a fantasy (Draft L [1950a (1895)]) to that of a genuine intra-instinctual process, the transformation of object libido into ego libido before it could assume new aims (1923b).

The unresolved complexity of the notion of sublimation means, however, that the term designates a set of questions rather than a well-circumscribed concept (Laplanche, 1980).

Sublimation would appear to be a very special vicissitude of the instinct, for its diversion of libidinal energy harnesses instinctual impulses in a way congenial to the superego and its society. Retransformation is possible, however, and therein the original instinc-

tual force may regain the upper hand (resexualization of sublimated homosexual impulses (1911c [1910])). Desexualization alone cannot define the process of sublimation, which is not to be confused with inhibition or reaction formations, even if it plays a fundamental role because of its ability to exchange an originally sexual aim for another, which is its “psychical parent” (1908d).

As for the effect of sublimation on the object it valorizes in the eyes of society, Freud took great care to discourage any risk of confusion between sublimation and idealization, the latter implying an *overestimation* of the supposedly “sublime” object (1914c).

The development of the ability to sublimate (“*Fähigkeit zur Sublimierung*”) was related for Freud both to the individual’s constitutional disposition (the initial strength of the sexual instinct) and to the events of childhood (the link between trauma and the intensity of infantile curiosity; cf., the case of Leonardo da Vinci being a good example). Sublimation occurred at the expense of the polymorphously perverse drives of childhood (especially bisexuality), which were diverted and applied to other aims, as witness the sublimation of anal eroticism into an interest in money, or the link between urethral eroticism and ambition. This process contributed to the formation of character traits. The component instincts were of particular significance here: the instinct to see could be sublimated into artistic contemplation and into the instinct to know (1910c), while sublimated aggression could manifest itself as creative and innovative activity.

But Freud always emphasized the risks associated with sublimation of the instincts when it takes place at the expense of the sexual and deprives the subject of immediate satisfaction. Although sublimation appears as the guarantor of the social bond and promoter of culture, it is, nonetheless, a dangerous demand, a “ruse of civilization” (Mellor-Picaut, 1979) when it presents individual sublimations as ideal models. For Freud, sublimation is not the core of an axiological approach to psychoanalysis, and the introduction of narcissism represented an important turning point in his theory. Sublimation took place “through the mediation of the ego, which begins by changing sexual object-libido into narcissistic libido, and then perhaps goes on to give it a different aim” (1923b, p. 30). Sublimation no longer occurs at the expense of the object-libido but offers the narcissistic libido a needed extension. However, it does not pro-

tect the individual, who is left at the mercy of the death instinct.

Freud was against making sublimation a privileged goal of the treatment, one that could even be advocated by the analyst (1915a [1914]). In this, he disagreed with Carl G. Jung (1914d), as well as Lou Andreas-Salomé, whom he had also accused of “blabbering about the ideal” in his letters to Jung (January 10, 1912), James J. Putnam (May 4, 1911), and Oskar Pfister (October 9, 1918). In all these cases he was struggling against the temptation of an anagogic approach to psychoanalysis. It may be assumed that this threat of having such a complex concept corrupted contributed to the fact that it has never been thoroughly developed. One thinks in particular of an unpublished draft on sublimation written for Freud’s projected book on metapsychology.

The concept of sublimation has been discussed by many of Freud’s followers, though without any significant contributions being made to metapsychology. In later years Melanie Klein became one of the most important commentators on sublimation, primarily in connection with epistemophilia. In France, Daniel Lagache (1962) and Jean Laplanche (1980) have both written essays on sublimation.

Sublimation, which is often mentioned in the literature, by emphasizing the desexualization of goals and the social valorization of the object, remains both an essential concept and an unresolved question for psychoanalysis.

SOPHIE DE MIJOLLA-MELLOR

*See also:* Anality; Analytic psychology; Anthropology and psychoanalysis; Applied psychoanalysis and the interactions of psychoanalysis; Character; Civilization (*Kultur*); Defense; Depressive position; Desexualization; Drive; Ego; Ego autonomy; *Ego and the Id*, *The*; *Ego and the Mechanisms of Defense*, *The*; Eroticism, anal; Eroticism, urethral; Friendship; Group psychology; Healing; Idealization; Identification with the aggressor; Ideology; Intellectualization; Knowledge (instinct for); Latency period; Law of the Father; *Leonardo da Vinci and a Memory of his Childhood*; Pleasure ego/reality ego; Pleasure of thinking; Psychic apparatus; Reaction formation; Reciprocal paths of influence (libidinal coexcitation); Reparation; Repetition; Rite and ritual; Science and psychoanalysis; Sexuality; Superego; Symbol; Symbolization, process of; Thought; Work (as a psychoanalytic concept); Working-off mechanisms.

### Bibliography

- Freud, Sigmund. (1908d). "Civilized" sexual morality and modern nervous illness. *SE*, 9: 177–204.
- . (1910c). *Leonardo da Vinci and a memory of his childhood*. *SE*, 11: 57–137.
- . (1915a [1914]). Observations on transference love. (Further recommendations on the technique of psychoanalysis III). *SE*, 12: 157–171.
- . (1914d). *On the history of the psycho-analytic movement*. *SE*, 14: 1–66.
- . (1930a [1929]). *Civilization and its discontents*. *SE*, 21: 57–145.
- . (1923b). The ego and the id. *SE*, 19: 1–66.
- Lagache, Daniel. (1984). *La sublimation et les valeurs*. In *Oeuvres complètes 5*. Paris: Presses Universitaires de France. (Original work published 1962)
- Laplanche, Jean. (1980). *Problématiques III, la sublimation*. Paris: Presses Universitaires de France.
- Mellor-Picaud, Sophie. (1979). La sublimation ruse de la civilisation. *Psychanalyse à l'Université*, 4.

### Further Reading

- Arlow, Jacob, rep. (1955). Panel: Sublimation. *Journal of the American Psychoanalytic Association*, 3, 515–527.
- Kris, Ernst. (1955). Neutralization and sublimation. *Psychoanalytic Study of the Child*, 10, 30–46.
- Loewald, Hans W. (1988). *Sublimation: Inquiries into theoretical psychoanalysis*. New Haven: Yale University Press.

## SUBSTITUTE/SUBSTITUTIVE FORMATION

"Substitute" or "substitutive formation" refers to the psyche's replacement of a fact or mental object through unconscious chains of association. In the substitution, an idea, thought, or object perceived as incompatible with the ego is repressed and exchanged for another. A number of synonyms are found in Sigmund Freud's writings: "ersatz," "substitutive formation," "equivalent," "stand-in," and "replacement."

In "The Neuro-Psychoses of Defence" (1894a), Freud described the formation of an obsessional idea as a substitute for an incompatible sexual idea. The ego wishes to deal with the sexual idea as though it had never arisen, and so affect is detached from it. However, since that affect remains "unaltered and

undiminished" (p. 54) in the core of the psyche, it attaches itself to a compatible idea, making it obsessional. Initially limited to obsessional ideas, the notion of substitution was eventually generalized and conceptually modified. For instance, in "Obsessions and Phobias: Their Psychical Mechanism and Their Aetiology" (1895c [1894]), Freud described symptoms as substitutes for ideas of coitus. In "Obsessions and Phobias," he posited premature sexual climax as the source of reproaches, for which the psyche substitutes ideas, actions, or impulses providing relief and protection. In "Further Remarks on the Neuro-Psychoses of Defence" (1896b), the object of the substitution is no longer mnemonic contents, but rather the reproach associated with them, which is transformed into another unpleasurable substitutive affect that can become conscious (shame; social, religious, or hypochondriacal anxiety; etc.).

In later works, the substitute was associated with different metapsychological objects. It was associated with object relations, with maternal and paternal substitutes being associated through family romances and the totem. It was associated with anxiety contents in the case history of Little Hans (1909b), where the paired terms bitten/castrated correspond to the paired objects horse/father. It was associated with dreams in "Some General Remarks on Hysterical Attacks" (1909a [1908]), where the dream is a substitute for the hysterical attack, itself a substitute for an autoerotic satisfaction from childhood. Dreams there became more extensively recognized as substitutive formations. Finally, *Inhibitions, Symptoms, and Anxiety* (1926d [1925]) brought the substitute back to the level of the symptom, in that the substitute represents a return of the repressed. In this sense, symptom formation and substitutive formation have the same upshot: replacing the forbidden satisfaction of instincts and making such satisfaction unrecognizable.

Even though the terms are synonymous, the expression "substitutive formation" is preferable to "substitute" because it attests to the dynamic process that forms the substitute: the transformation of gratification in the defensive conflict.

MATHIEU ZANNOTTI

*See also:* Abstinence/rule of abstinence; Addiction; Adolescence; Alcoholism; Anorexia nervosa; Breastfeeding; Bulimia; Conflict; Displacement; Ego ideal; Erotogenic

zone; Fetishism; Maternal; Metaphor; Metonymy; Phallic woman; Signifier/signified; Splitting; “Splitting of the Ego in the Process of Defence”; Substitutive formation; Symbol; Symbolization, process of; Symptom-formation; Thought; Totem/totemism; Word-presentation.

### **Bibliography**

- Freud, Sigmund. (1894a). The neuro-psychoses of defence. *SE*, 3: 41–61.
- . (1895c [1894]). Obsessions and phobias: their psychological mechanism and their aetiology. *SE*, 3: 69–82.
- . (1896b). Further remarks on the neuro-psychoses of defence. *SE*, 3: 157–185.
- . (1909a [1908]). Some general remarks on hysterical attacks. *SE*, 9: 227–234.
- . (1909b). Analysis of a phobia in a five-year-old boy. *SE*, 10: 1–149.
- . (1924c). The economic problem of masochism. *SE*, 19: 155–170.
- . (1926d [1925]). Inhibitions, symptoms, and anxiety. *SE*, 20: 75–172.

---

## **SUBSTITUTIVE FORMATION**

The name “substitute formation” has been applied to the defensive process by which a symptom—but also, more generally, a failed act, slip of the tongue, or dream—is produced. The result of this process—for example, the act or manifest text of a dream—is that desire can find a way out, and its economic charge find an outlet.

The notion of substitute formation appeared in Freud in 1895, in his article on anxiety neurosis (1895b), but it was anticipated in the previous year in his work on “The Neuro-Psychoses of Defense” (1894a). In this, he described a “transposition,” a “displacement” connected with an economic charge (for example, anxiety or sexual excitement) and with a “complex of representations” (in a process of symbolic transposition), these two processes being able to function separately.

Freud resorted frequently to this idea in the following years: this was, in fact, a key notion in the metapsychology he was drafting, since he was describing the mechanism by which the repressed element could succeed in returning to conscious life and to behavior. At first, he limited the application of this mechanism

to obsessional neurosis. But the dual function attributed to it (economic discharge and symbolic transposition), the unification of the field of the return of the repressed (including neurotic symptoms, dreams, slips of the tongue, failed actions, and some “normal” behavior), its contiguity with related notions (like those of compromise formation or reactive formation), and the deepening of Freud’s thoughts on mechanisms of defense, all led him to the expression of much wider views on the subject in 1915 (notably in “Repression” [1915d] and “The Unconscious” [1915e]). He revised it even further in *Inhibitions, Symptoms and Anxiety* (1926d), as part of his overall views on symptom formation and his second theory of anxiety.

ROGER PERRON

*See also:* Compromise formation; Formations of the unconscious; Psychogenic blindness; Reaction-formation; Repressed, derivative of the, derivative of the unconscious; “Repression,” Substitute/substitutive formation.

### **Bibliography**

- Freud, Sigmund. (1894a). The neuro-psychoses of defence. *SE*, 3: 41–61.
- . (1895b [1894]). On the grounds for detaching a particular syndrome from neurasthenia under the description “anxiety neurosis.” *SE*, 3: 85–115.
- . (1915d). Repression. *SE*, 14: 141–158.
- . (1915e). The unconscious. *SE*, 14: 159–204.
- . (1926d). Inhibitions, symptoms and anxiety. *SE*, 20: 75–172.

---

## **SUCKING/THUMBSUCKING**

In *Three Essays on the Theory of Sexuality* (1905d), Sigmund Freud describes thumb-sucking as “rhythmic repetition of a sucking contact by the mouth (or lips). There is no question of the purpose of this procedure being the taking of nourishment” (pp. 178–180). Sucking itself is defined as a sexual autoerotic pleasure, “as a sample of the sexual manifestations of childhood” (p. 179).

From this point on, the infant’s sucking activity served for Freud as an exemplary case, enabling him to demonstrate how the sexual instinct seeks satisfaction

through a separate, vital, self-preservative function; it subsequently becomes autonomous and seeks satisfaction through auto-erotism. At the end of his life, in *An Outline of Psycho-Analysis* (1940e [1938]), Freud reaffirmed its significance: “The baby’s obstinate persistence in sucking gives evidence at an early stage of a need for satisfaction which, though it originates from and is instigated by the taking of nourishment, nevertheless strives to obtain pleasure independently of nourishment and for that reason may and should be termed *sexual*” (p. 154). Beginning in 1915, Freud described an aggressive “cannibalistic” oral stage that aims at incorporation, with emphasis not only upon the erotogenic zone but also upon the object to be incorporated.

A number of analysts have investigated the broader issues surrounding the activity of sucking and the oral stage. Freud suggested that an infant would “pronounce the act of sucking at his mother’s breast by far the most important in his life” (1916–17a [1915–17], p. 314); in fact, the act of sucking can be recognized from the twelfth to the thirteenth week of intrauterine life, as the fetus opens and closes its mouth in a more or less rhythmic manner. From the twenty-second week, the fetus is able to taste amniotic fluid and can suck its thumb.

Karl Abraham distinguished the passive sucking of the first stage of oral activity from the sadistic pleasure in the second, after teething, and he developed the concept of a cannibalistic oral stage that Freud discussed after 1915. René Spitz accorded sucking a principal role, which he integrated into his global approach of the genesis of the object. The “primal cavity” (Spitz, 1955) serves as a juncture for activities occurring around the mouth, tongue, and hand; sucking thus occurs at the juncture of inside and outside.

Michael Balint, after objectively recording the breast-feeding of about one hundred infants, maintained that rhythmic sucking is one of the most archaic qualities of human life and that each infant has an individual rhythm that adumbrates character traits. John Bowlby (1969) challenged Freud’s concept of “anaclitic” object choice as well as the primacy of sucking, suggesting instead that an innate need for social contact is at the root of attachment-seeking behavior. Sucking is only one of several instinctive behaviors at the child’s disposal; others include grabbing, following with the eyes, crying, smiling, and rooting behavior. Bowlby, while questioning the primacy of the oral

stage and sucking, did not take into consideration intrapsychic processes; new approaches to understanding these issues developed out of work on autism.

Frances Tustin, in *Autism and Childhood Psychosis* (1973), has suggested that the pain endured by autistic children in their experiences of bodily separateness as “amputation” would include an unbearable disjunction of the mouth and nipple. Sucking prevents the intolerable pain of this disjunction and thereby protects infants from anxieties of catastrophic separation. Donald Meltzer believed that the infant may experience the nipple, while sucking at the breast, as an eye-breast, or primitive, archaic superego.

Geneviève Haag has suggested that the thumb-in-the-mouth forms part of what she calls the “corporeal identification” with “assembly along the median.” This “self-junction” which infants create via the thumb-in-mouth represents a kind of clinging to self that precedes auto-erotic activity. According to her, the eye-to-eye visual exchanges that accompany breast-feeding go on to form the early feeling of being enveloped, the internal center of early attachment.

Whether conceived as auto-sensual or autoerotic behavior, bodily symbolization, intracorporeal identification, or incorporation, sucking is an activity that the understanding of which, ever since Freud, has been central to attempts at understanding normal and pathological development in the human infant.

ANNE-MARIE MAIRESSE

*See also:* Ambivalence; Anaclysis/anaclitic; Autoerotism; Breastfeeding; Cruelty; Eroticism, oral; Erotogenic zone; Libidinal development; Oral stage; Orality; Organ Pleasure; Psychosexual development; Self-preservation.

### **Bibliography**

- Bowlby, John. (1971). *Attachment and loss*. London: Hogarth; Penguin Books. (Original work published 1969)
- Freud, Sigmund. (1905d). Three essays on the theory of sexuality. *SE*, 7: 123–243.
- . (1916–17a [1915–17]). Introductory lectures on psycho-analysis. Part I, *SE*, 15; Part II, *SE*, 16.
- . (1940a [1938]). An outline of psycho-analysis. *SE*, 23: 139–207.
- Haag, Geneviève. (1991). Nature de quelques identifications dans l’image du corps. Hypothèses. *Journal de la psychanalyse de l’enfant*, 10: 73–92.

Spitz, René. (1955). The primal cavity: A contribution to the genesis of perception. *Psychoanalytic Study of the Child*, 10, 215–40.

Tustin, Frances. (1973). *Autism and childhood psychosis*. New York: Jason Aronson.

---

## SUDDEN INVOLUNTARY IDEA

Sudden involuntary ideas (*Einfälle*) appear at the borderline between images and words; they come to mind without apparent relation to what preceded them and have a quality of certainty linked to their immediacy.

This notion appears several times in Sigmund Freud's writings. It refers to preconscious thought activity as it is found in free association, jokes, or poetic creation that escapes critical reason, allowing the outcome of an earlier development to emerge into consciousness.

In *The Interpretation of Dreams* (1900a), Freud gave *Einfälle* a status analogous to that of “involuntary ideas” (p. 102) that are transformed into visual or auditory images. Divided diffuse attention is responsible for these representations, as they are found in a semi-sleeping state or under hypnosis. In this work Freud discussed the associationist hypotheses of Eduard von Hartmann, saying that although *Einfälle* appear when there has been a renunciation of purposive ideas, this does not mean that they are arbitrary; rather, there are other, unconscious purposive ideas that take over and determine the course of involuntary ideas. The work of analysis thus relies on *Einfälle*, but attempts to guide them back into the realm of the interpretable and eliminate their “sudden” and “involuntary” quality, which is a result of repression.

*Einfälle* are particularly important in creative thought in general, whether in the discovery of unconscious contents in psychoanalysis, the punch line in a joke, poetic creation, or invention in theoretical or abstract thinking (cf. Archimedes's “Eureka!”). Nevertheless, their origin, unknown because it is repressed, has something troubling about it—hence Freud's inclusion, in *The Interpretation of Dreams*, of the following quotation by Friedrich von Schiller: “[W]here there is a creative mind, Reason—or so it seems to me—relaxes its watch upon the gates, and the ideas rush in pell-mell, and only then does it look them through and examine them in a mass.—You critics, or whatever else you may call yourselves, are ashamed or

frightened of the momentary and transient extravagances which are to be found in all truly creative minds and whose longer or shorter duration distinguishes the artist from the dreamer. You complain of your unfruitfulness because you reject too soon and discriminate too severely” (p. 103).

SOPHIE DE MIJOLLA-MELLOR

See also: Free association; *Interpretation of Dreams, The*; Jokes.

### Bibliography

Freud, Sigmund. (1900a). The interpretation of dreams. *SE*, 4–5: 1–625.

Mijolla-Mellor, Sophie de. *Le Plaisir de pensée*. Paris: Presses Universitaires de France, 1992.

### Further Reading

Epstein, A. (1995). *Dreaming and other involuntary mentation. An essay in neuropsychiatry*. Madison, CT: International Universities Press.

---

## SUFFERING

Suffering is the result of a feeling of alienation and insurmountable ambivalence; being a defensive attitude, its aim is the reduction of anxiety.

When Sigmund Freud asserts in *Civilization and Its Discontents* (1930a) that “the three sources from which our suffering comes” are “our own body... the external world... and our relations to other men” (pp. 86, 87), he could not make it clearer that human suffering opens up the entire field of psychopathology. The classical medical tradition has always sought to name the condition that causes the patient to suffer, thus to satisfy the patient's wish for their suffering to be less mysterious. Psychoanalysis escapes this preoccupation with diagnosis in that it demonstrates the ubiquity of a suffering that is at once undergone and created by the subject.

If suffering marks the entry into the treatment, the orientation of the treatment itself is towards a demonstration of how this suffering is provoked by the individual subject, in the name of a particular search for pleasure “in a different place” (Laplanche, Jean, 1976 [1970], p. 104). Suffering is thus not only the source of

the complaint, but also the necessary lever of its own mobilization and even its own transcendence by the treatment.

In the tradition of Freud's work on "Mourning and Melancholia" (1916–17g [1915]), Melanie Klein (1935) treated accession to the depressive position as a fecund moment in the development of the child's object-relationships and the harbinger of the processes of symbolization. The same intimate connection between suffering and thought-processes informs Christian David's notion that man is in a sense "destined to suffer": "We cannot avoid being permanently confronted by separation and loss, by absence, by intersubjective and intrapsychic splits whether fantasied or actual... If the psyche drew no strength from its own division, it would no doubt be unable to tolerate this state of affairs for long and would be liable to disintegrate at the first jolt" (1983).

Interpretation during the treatment depends largely on the effectiveness of a process of working-through, toward the relief of suffering. As arduous as this work may be for those who embark on it, they feel motivated to do so by a wish to live better, even to be "cured." It is by no means certain that insight leads to cure. Analysts are only too well aware of the effects of the repetition compulsion and of primary masochism, only too familiar with clinical pictures that lie beyond the reach of the regulatory mechanism of the pleasure-unpleasure principle. The "work of the negative" may even become indistinguishable from what is irreducible or radically unthinkable due to the opacity of suffering—merging, in effect, with what Jean-Bertrand Pontalis (1981) calls the principle of pain, *jouissance*, or agony (in the sense of Donald Winnicott's "primitive agonies" [1974]): "The logic of unpleasure/pleasure seems to give way to, or even to be completely overwhelmed by a logic of despair that reduces our logic, that of the primary as much as that of the secondary processes, to despair."

DRINA CANDILIS-HUISMAN

*See also:* Autism; Breakdown; "Confusion of Tongues between Adults and the Child"; Cure; Failure neurosis; Guilt, feeling of; Helplessness; Hypochondria; Masochism; Need for punishment; Negative, work of; Negative therapeutic reaction; Pain; Passion; Pleasure in thinking; Primitive agony; Psychoanalytic treatment; Psychotic potential; Self-mutilation in children; Sadism; Self-punishment; Traumatic neurosis.

## Bibliography

- David, Christian. (1983). *Souffrance, plaisir et pensée, un mixte indissociable*. In *Souffrance, plaisir et pensée*. Paris: Les Belles Lettres.
- Freud, Sigmund. (1916–17g [1915]). Mourning and melancholia. *SE*, 14: 237–258.
- . (1930a). Civilization and its discontents. *SE*, 21: 57–145.
- Klein, Melanie. (1975). Contribution to the psychogenesis of manic-depressive states. In *Love, guilt and reparation and other works, 1921–1945* (The writings of Melanie Klein, vol. 1), London: Hogarth/Institute of Psycho-Analysis; New York: Delacorte/Seymour Lawrence. (Original work published 1935)
- Laplanche, Jean. (1976 [1970]). *Life and death in psychoanalysis*. (Jeffrey Mehlman, Trans.) Baltimore: Johns Hopkins University Press.
- Pontalis, Jean-Bertrand. (1981). Non, deux fois non. *Nouvelle Revue de Psychanalyse*, 24.
- Winnicott, Donald W. (1974). Fear of breakdown. *International Review of Psycho-Analysis*, 1, 103–7.

## SUGGESTION

James Braid, the British doctor who popularized hypnotism, was the first to use the term "suggestion" to describe experiments in which the hypnotist, using a gesture or word, triggers the subject's automatic obedience. Around 1860 Ambroise Liebeault decided to make use of suggestion for therapeutic purposes: orders, formulated in an authoritarian or well-meaning manner, would help trigger hypnosis and the therapeutic process. Hippolyte Bernheim extended this by claiming that suggestion had explanatory powers. In 1891 he defined suggestion as "the act through which an idea is introduced into the brain and accepted by it." According to Bernheim, an idea suggested verbally by the operator triggered a representation-adherence on the part of a subject endowed with "*crédibilité*." Unless inhibited, this idea tended to be translated into actions ("ideo-dynamism").

Bernheim noted that some subjects were more susceptible than others and used the term "suggestibility" to describe the ability to respond to suggestion. Contrary to Jean Martin Charcot, he did not see this as pathological, but as a very general psychological phenomenon, present to a varying degree in everyone. Thus, suggestion helps to explain hypnosis as well as

the mechanism or process of education, the adherence to a belief, and so on.

Gabriel de Tarde in *Les Lois de l'imitation* (1890), and Gustav Le Bon, in *La Psychologie des foules* (1895), used suggestion to describe the connection between two or more people that serves as the basis for a society or a crowd. For Bernheim, however, hypnosis only facilitated therapeutic suggestibility, and suggestive psychotherapies could be practiced in a waking state. This identification of hypnosis with suggestion resulted in criticism from Liebeault, and especially from Charcot and his followers.

Originating in the School of Nancy, for which Bernheim was the spokesman, all of Europe took an interest in experiments, therapies, and models of suggestion. Experiments were conducted on “suggested” crimes, which triggered theoretical, ethical, and juridical polemics. Although experiments with suggestion were met with trepidation, its therapeutic use generated tremendous hope. It was believed it would be able to eliminate certain symptoms, like pain, associated with organic illnesses and heal “nervous disorders” such as hysteria, as well as sexual inversion and alcoholism.

Suggestion, as a therapy and as a concept, raised questions and criticisms from many of its practitioners. Bernheim remarked that some subjects can present resistance to “direct suggestion.” In such cases it is better not to give a direct order, but rather to tell the patient nothing can be done, and the problem will heal itself. In this context Bernheim also spoke of “indirect suggestion,” an expression used in a similar sense by Charcot and his school. The Belgian Joseph Delboeuf emphasized self-suggestion, the ability to resist, and the will of the patient. The Dutch practitioner Frederik Van Eeden, who was, like Delboeuf, part of the Nancy School, pointed out that suggestive psychotherapy must involve collaboration between the doctor and his patient, respecting the patient’s autonomy to as great an extent as possible. Pierre Janet criticized the overly broad extension given to the concept of suggestion and proposed, in 1889, in *L’Automatisme psychologique*, a more limited definition: “The influence of one person on another, who carries it out without the intermediary of voluntary consent.” At the same time he reactivated the older notion, associated with animal magnetism, of “rapport.” Auguste Forel, a Swiss practitioner, noted the ambiguity of the word suggestion, which designates both a therapeutic procedure associated with an order from the practitioner

and a psychic process that leads the subject to respond to someone else’s influence.

The articles Freud wrote in 1895 on hypnosis and suggestion situate him within the critical movement outlined above. He subsequently abandoned suggestion both as a therapeutic practice and as a psychological explanation. Nonetheless, he claimed in the *Introductory Lectures on Psychoanalysis* (1916–17a) that “in our technique we have abandoned hypnosis only to rediscover suggestion in the shape of transference” (p. 446). Although we can do away with suggestion, the problems associated with the process remain and have been shifted toward the transference. In 1921 Freud returned to the question of hypnosis and suggestion, and of suggestion as a model of the social bond.

Looking at contemporary techniques of hypnosis, we find that the therapies inspired by Milton Erickson have reactivated the identification of hypnosis with suggestion. The procedures used (the proposal of metaphors, paradoxical orders, or prohibitions) seem less authoritarian than those employed at the end of the nineteenth century, but may still be compared to the “indirect suggestion” used in the past.

JACQUELINE CARROY

*See also:* Anticipatory ideas; Autosuggestion; Bernheim, Hippolyte; Cathartic method; Cognitivism and psychoanalysis; Congrès international de l’hypnotisme expérimental et scientifique, Premier; “Constructions in Analysis;” First World War: The effect on the development of psychoanalysis; Fundamental rule; *Group Psychology and the Analysis of the Ego*; Hypnosis; Janet, Pierre; Lie; Liebeault, Ambroise Auguste; “Lines of Advance in Psycho-Analytic Therapy”; *Qu’est-ce que la suggestion?* (What is suggestion?); Self-consciousness; Transference; Unconscious, the.

### **Bibliography**

- Carroy, Jacqueline. (1991). *Hypnose, suggestion et psychologie: l’invention de sujets*. Paris: Presses Universitaires de France.
- Chertok, Léon, and Stengers, Isabelle. (1992). *A critique of psychoanalytic reason. Hypnosis as a scientific problem from Lavoisier to Lacan* (Martha Noel Evans, Trans.) Stanford, CA: Stanford University Press. (Original work published 1989)
- Ellenberger, Henri. F. (1970). *The discovery of the unconscious: The history and evolution of dynamic psychiatry*. New York: Basic Books.



Freud, Sigmund. (1921c). Group psychology and the analysis of the ego. *SE*, 18: 65–143.

Gauld, Alan. (1992). *A history of hypnotism*. Cambridge: Cambridge University Press.

## SUICIDAL BEHAVIOR

The term *suicidal behavior* is understood to mean both suicidal equivalents not recognized as such (accidents, repeated risk-taking) and repeated suicide attempts whose chronic and unsuccessful nature certainly constitutes a real risk, but which are also acts of essentially relational significance.

The idea that accidents can be interpreted as unconscious suicide attempts appeared in Sigmund Freud's *The Psychopathology of Everyday Life* (1901b): “[I]n addition to consciously intentional suicide there is such a thing as a half-intention self-destruction [sic] (self-destruction with an unconscious intention), capable of making skillful use of a threat to life and of disguising it as a chance mishap. There is no need to think such self-destruction rare. For the trend to self-destruction is present to a certain degree in very many more human beings than those in whom it is carried out” (pp. 180–181). This essentially involves the person waiting for the occasion that will divert the forces of personal preservation, and there is thus a “meeting” between the event and the unconscious intention. Involuntary mutilations, which constitute a compromise between the self-destructive tendency and self-preservation, are also included within the framework of accidental suicidal behaviors.

Similarly, with regard to accidents that happen to babies, Melanie Klein spoke of suicide attempts with inadequate means, as if the infant did not yet have the ability to fantasize and premeditate its own death, and that it could only realize by unconsciously putting itself in danger.

In a letter to Freud dated 1 June 1911, Ernest Jones proposed a comparison between accidental suicide and “with the way in which the unconscious seizes on unassociated indifferent material in dream making” (1993 [1908–39], p. 105).

Systematic risk-taking requires a different psychic disposition. The idea of the possibility of death is present and even hypercathected, but at the same time denied in a megalomaniacal narcissistic affirmation. Death is thus “provoked” in the sense of a challenge

that is also a relational challenge to those whose fantasized omnipotence cannot effectively protect the subject, the idealized parents. These situations are very common, especially during adolescence, and can involve the risk of accidents, but also toxic risks or even anorexia. Such risk-taking has a function similar to that of the *ordalia*, or trial by ordeal, in the sense that the subject expects to get from it an affirmation, if not of their own innocence, at least of their invulnerability. In the face of this excessiveness, the accident imposes a limit and brings the person into contact with reality, including that of the body's fragility.

Authors such as Philippe Jeammet and Elisabeth Birot who have studied suicide attempts in adolescents have emphasized the fact that the idea of death has an organizing function during adolescence. It can be noted that the idea of death is unavoidable at this age in conjunction with the obligation to renounce childhood, to which there is no possible return. The idea of death is linked to a sense of the ephemeral—hence the ease during this period of identifying with romantic heroes (as seen in Freud's Manuscript N., 31 May 1897, regarding Goethe's hero Werther).

Beyond gambling with the idea of death, a suicide attempt can represent a way of trying to restore a lost identity (the prepubescent body of the anorexic) or a delusional identity. Similarly, the integration of the drives during adolescence, notably with respect to homosexuality, is a factor that can be conducive to suicidal behavior. Such behavior then appears in its relational significance, whether in the form of a threat, or even blackmail against those close to the subject, or a call for help when communication has broken down. Chronic suicidal behavior can have various etiologies; it remains the case that it cannot be dissociated from suicide proper, the potential for which is inherent in it.

SOPHIE DE MIJOLLA-MELLOR

*See also:* Suicide.

### **Bibliography**

Freud, Sigmund. (1901b). The psychopathology of everyday life. *SE*, 6.

Freud, Sigmund, and Jones, Ernest. (1993 [1908–1939]). *The complete correspondence of Sigmund Freud and Ernest Jones, 1908–1939* (R.A. Paskauskas Ed.). London: The Belknap Press of Harvard University Press.

Garfinkel, Barry D.; Froese, A.; and Hood, J. (1982). Suicide attempts in children and adolescents. *American Journal of Psychiatry*, 139, 10, 1257–1261.

Jeammet, Philippe, and Birot, Elisabeth (Eds.). (1994) *Étude psychopathologique des tentatives de suicide chez l'adolescent et le jeune adulte*. Paris: Presses Universitaires de France.

### Further Reading

Hartmann, H. P., and Milch, W. (2000). Efficacy treatment of suicidal patients: Transference and countertransference. *Progress in Self Psychology*, 16, 87–102.

## SUICIDE

Suicide is a symptomatic act connected most frequently to the framework of depression and melancholy. Its etiology is varied and complex, since it is characterized by the collapse of the ego, along with self-reproach and a diminution or a loss of self-esteem—and, at the same time, by a magic omnipotence which allows the annihilation of internal persecutors, as well as a manic feeling based on the denial of death itself. While suicide may appear to be a response to persecutory guilt, it is also a projection of this guilt onto objects as well as a liberation from their control through the death the subject has chosen for himself.

Suicide was discussed in the psychoanalytic literature as early as 1907, as recorded in the *Minutes of the Vienna Psychoanalytic Society* (Nunberg, Hermann, and Federn, Ernst, 1962–75), but it was a rather superficial discussion, centered on the fact that the differing choice of means by men and women reveals a primal sexual symbolism. From this came the formula that “suicide is the climax of negative autoerotism” (*Minutes*, Vol. 1, February 13, 1907, p. 114). This should be understood in the context of the opposition between the ego instincts and sexual instincts in Freud’s earliest theorization: “In suicide the life instinct is overwhelmed by the libido” (Vol. 2, April 20, 1910, p. 494).

In this approach, suicide, interpreted as a substitute for psychosis, seems linked both to an inability to tolerate reality and to autoerotic regression: “Suicide is an act of defense of the normal ego against psychosis” (June 6, 1907). Drive regression is equally central to Freud’s ideas on the subject of the suicide of high school students; at school “Teachers. . . must exercise a

life-maintaining influence. [The function of] school is to give the child, in this stage of his detachment from his parents, a new footing within a larger relationship” (Vol. 2, April 20, 1910, p. 495). This should extend as far as not to “deny them the right to linger even in those phases of their development that seem vexing.” There might well have been some evolution in Freud’s thought here, especially if it is considered that, at the very beginning he insisted on the connection between neurasthenia, masturbation, and the risk of suicide. However, Freud also stressed that “in many cases it is the fear of incest itself that drives [children] to suicide” (p. 494), because of the enormous augmentation of their need for love at puberty; Freud went so far as to suggest, this being the case, that homosexuals make the best teachers, the worst being those whom the repression of their homosexuality has turned into sadists, pushing their students to suicide.

Later psychoanalytic thought on suicide followed the main ideas of Freud on the subject. First of all, in the depressive context, suicide was considered self-punishment for the desire to kill, primarily directed toward another, as Freud himself stated in *Totem and Taboo*: “The law of talion, which is so deeply rooted in human feelings, lays it down that a murder can only be expiated by the sacrifice of another life: self-sacrifice points back to blood-guilt” (1912–13a, p. 154). Since then, the risk of self-mutilation or suicide with infantile or borderline personalities has been much emphasized (Kernberg, Otto, 1984); this risk is especially a factor during fits of rage following disappointments which are blamed on others; or else there is a risk of suicide because of failure to achieve success (guilt), or, even the failure of the cure (negative therapeutic reaction).

In fact, the idea that suicide is self-punishment for the desire to kill someone else cannot be understood completely apart from the process of melancholia, whereby the loved/hated object has been introjected within the ego and has become the target of the attack. More even than “self-punishment,” suicide would be murder of the other within oneself. “Probably no one finds the mental energy required to kill himself unless, in the first place, in doing so he is at the same time killing an object with whom he has identified himself, and, in the second place, is turning against himself a death-wish which had been directed against someone else” (1920a, p. 162). Freud explained that “the ego is destroyed by the object.”

The enigma constituted by suicide in relation to the self-preservative or ego instincts has also been approached in another way, through considering that it is accompanied paradoxically by a tentative intent to reappropriate vital energy, or, indeed, is even prompted by the fantasy of beginning a new life (Grinberg, León, 1983). Accordingly, suicide would result from a state of crisis dominated by the feeling that something must change. The person committing suicide “convokes death imaginally to assure himself paradoxically that life exists” (Triandafillidis, Alexandra, 1991). Ideal images of oneself and others can then survive, at the price of the death of the bad objects cluttering the ego.

The vital stakes involved in this symptomatic conduct have inclined authors not only to attempt to understand the suicidal mechanism, but also to describe its advance symptoms, evaluating the risk of suicide in order to decide on a therapeutic approach, especially in a care-giving institutional setting. León Grinberg (1983) emphasized suicidal premeditation and the fact that a suicidal plan follows the idea of suicide, which was at first only a way of dealing with anxiety. Continuing to the act of suicide depends on an “encounter,” which might favor tipping the fantasy into reality. This author also examined factors of present or past vulnerability (feeling of culpability, narcissistic wound, loss of loved object, and so forth). Otto Kernberg (1984) emphasized the need for the therapist not to be fooled by an accentuation of the manic element; he stressed the seriousness of cases where “aggressiveness has infiltrated the grandiose Self,” joined to an inability to enter into interpersonal relations and feel emotions. These considerations, however, concern psychotherapeutic strategies rather than the etiology of suicide.

SOPHIE DE MIJOLLA-MELLOR

*See also:* Bettelheim, Bruno; Bjerre, Poul; Great Britain; Morgenstern-Kabatschnik, Sophie; Rosenthal, Tatiana; Secret; Silberer, Herbert; Sokolnicka-Kutner, Eugénie; Stekel, Wilhelm; Tausk, Victor.

### **Bibliography**

- Freud, Sigmund. (1912–13a). Totem and taboo. *SE*, 13: 1–161.
- Grinberg, León. (1983). *Culpabilité et dépression*. Paris: Les Belles Lettres.

Kernberg, Otto. (1984). *Les trouble graves de la personnalité*. Paris: Presses Universitaires de France.

Nuberg, Hermann, and Federn, Ernst. (1962–1975). *Minutes of the Vienna Psychoanalytic Society*. New York: International Universities Press.

Triandafillidis, Alexandra. (1991). *La dépression et son inquiétante familiarité*. Paris: Éditions Universitaires.

### **Further Reading**

Laufer, M. (Ed.). (1995). *The suicidal adolescent*. Madison, CT: International Universities Press.

---

## **SULLIVAN, HARRY STACK (1892–1949)**

American psychiatrist and psychoanalyst, born on February, 21, 1892, in Norwich, New York, and died on January 14, 1949, in Paris.

The only son of a farming couple in rural upstate New York, Sullivan had a very lonely childhood and went through a deep psychological crisis upon entering Cornell University. He graduated from medical school in Chicago in 1917, but only in 1921 did he start working in psychiatry, under William Alanson White (1870–1937) at St. Elisabeth’s Hospital, Washington, D.C. Between 1923 and 1930 he worked at Sheppard-Pratt Hospital, Maryland, where he devised a very successful combination of milieu and individual therapy aimed at young schizophrenic patients. A good friend of Abraham Brill and a charter member of the Washington Psychoanalytic Society (1930), Sullivan progressively withdrew from Freudian psychoanalysis in order to concentrate on initiatives like the Washington School of Psychiatry (1936), the journal *Psychiatry* (1938), and on the development of his own interpersonal theory. In the early 1940s, on the invitation of Dexter Bullard, he worked as teacher and supervisor at Chestnut Lodge Hospital, where he influenced a whole series of colleagues, among them Frieda Fromm-Reichmann (1889–1957).

In New York City in 1943, Sullivan, together with Clara Thompson, Erich Fromm, Frieda Fromm-Reichmann, and Janet and David Rioch founded the William Alanson White Institute, which became the major institution committed to the teaching and development of interpersonal psychoanalysis.

With the exception of *Conceptions of Modern Psychiatry* (1940), six of his seven books available in

English were published posthumously. *The Psychiatric Interview* is considered a classic and is still widely read.

MARCO CONCI

*See also:* Dismantling; Object relations theory; Schizophrenia; Second World War: The effect on the development of psychoanalysis.

### **Bibliography**

Perry, Helen Swick. (1982). *Psychiatrist in America. The life of Harry Stack Sullivan*. Cambridge, MA: The Belknap Press of Harvard University.

Sullivan, Harry Stack. (1940). *Conceptions of modern psychiatry*. Washington, DC: W.A. White Psychiatric Foundation.

———. (1953). *Interpersonal theory of psychiatry*. New York: W.W. Norton.

———. (1954). *The psychiatric interview*. New York: W.W. Norton.

———. (1962). *Schizophrenia as a human process*. New York: W.W. Norton.

## **SUM OF EXCITATION**

In his earliest psychological investigations Freud explored the interface between the psychological and the physical, a context in which a “sum of excitation” had the following connotations: (1) a quantity of energy present in the nervous system and its psychical manifestations: the greater or lesser strength and vividness of ideas and memories and of the affects bound to them; (2) a regulatory dynamic governing that energy: the tendency to establish constancy through abreaction and the failures of this tendency in neurosis; (3) the aggregate of excitations and their limits, in accordance with neurophysiology, in the emergence and overdetermination of symptoms; and (4) the idea that the energetic processes involved here are quantifiable and measurable.

As he worked on a proposed joint publication with Josef Breuer in 1892, Freud spoke of “the constancy of the sum of excitation” and “displacements . . . of sums of excitation” (1941a, pp. 147, 148; see also 1940a, p. 153–54). In his lecture “On the Psychical Mechanism of Hysterical Phenomena” (1893h), he introduced the notion as follows: “If a person experiences a psychical impression, something in his nervous system which we

will for the moment call the sum of excitation is increased. Now in every individual there exists a tendency to diminish this sum of excitation once more, in order to preserve his health. . . . and when someone cannot get rid of the increase in stimulation by ‘abreacting’ it, we have the possibility of the event in question remaining a psychical trauma” (pp. 36, 37).

Freud continued to use this expression until 1897. In its initial context, it was synonymous with “affect” or “amount of affect”; the fate of the sum of excitation in the event of repression was somatic innervation in the shape of hysterical conversion, and in the case of compulsive neurosis it underlay the creation of substitute ideas. But the notion that a principle of constancy affected the sum of excitation led Freud into overarching issues of dynamic and economic neuropsychology; this emerging set of problems was already present in the “quantities” Q and Qg of the “Project for a Scientific Psychology” (1950c [1895]).

An intuition in the early days, the idea of the sum of excitation and its attendant problems were bound to evolve. The notion of “cathexis” was soon added to those of affect and amount or quota of affect. The instincts and instinctual impulses refined the energetic model of the psyche, while the tendency toward constancy was broken down into principles of inertia, constancy, pleasure, reality, and eventually even into the death instinct. The vividness of repressed memories led to the notions of the timelessness of the unconscious and of repetition. And, lastly, the economic standpoint became the tool with which to study the centrality of the quantitative factor in the etiology of mental disturbances.

This idea was thus a rich theoretical seed, but it remained neurophysiological in character, and ultimately embodied too many other notions to survive in its original form.

MICHÈLE PORTE

*See also:* Conversion; Decathexis; Excitation; Hypercathexis; Principle of constancy; Psychosomatic limit/boundary; Quantitative/qualitative.

### **Bibliography**

Freud, Sigmund. (1941a [1892]). Letter to Josef Breuer. *SE*, 1.

———. (1950c [1895]). Project for a scientific psychology. *SE*, 1: 281–387.

Freud, Sigmund, and Breuer, Josef. (1893a). On the psychological mechanism of hysterical phenomena: Preliminary communication. *SE*, 2: 1–17.

———. (1940d [1892]). On the theory of hysterical attacks. *SE*, 1: 11–154.

## SUPEREGO

The superego is one of the three agencies making up the psychic apparatus in Freud's second topography, the structural theory (1923b). It results essentially from the internalization of parental authority. From the outset, as psychoanalysis uncovered the defensive conflict that arose from a repressed unconscious (childhood sexuality), it encountered the need to posit a repressing agency, a censor associated with self-esteem. In contrast with hypnosis, which put the censor to sleep, psychoanalysis is essentially aimed at acknowledging and working out of the ego's resistances.

As early as "On Narcissism: An Introduction" (1914c), Freud already deemed the ego ideal to be autonomous. Two works of Freud's dating from the early 1920s firmly differentiated between the ego and the superego (ego ideal) and integrated this distinction into the whole set of Freud's metapsychological reworkings of the period. In *Group Psychology and the Analysis of the Ego* (1921c), to describe the functioning of groups, Freud developed a generalized conception of identification in which individuals identified their egos by creating a common ideal, incarnated in a leader. *The Ego and the Id* (1923b) went on to link the superego as a mental agency to the recognized fact that the greater portion of the ego was unconscious. Within the psychic apparatus, the superego makes permanent the effects of the infant's dependence on primary objects, and it is just as insusceptible of complete integration into the ego as the id and its instinctual impulses. The term "superego" itself indicates that the superego dominates the ego; the tension between the two agencies take the form of moral anxiety.

Freud did not detach the superego from the ideal (one of its functions). The superego is responsible for transmitting the constraints that culture exercises over the individual, and for imposing the necessary and ultimately excessive sacrifices of instinct demanded by civilization. It is also the carrier of a cultural past that each subject must appropriate and master (the reference being to Goethe's *Faust*) through processes of

object idealization and sublimation of the instincts. The main dynamic remains the conflict-laden work of differentiation between the ego and the superego. How the superego is transmitted (it is formed in the image of the parents' own superegos), establishes itself, and develops entails in the final reckoning that the Freudian superego is an intersubjective and even intergenerational agency.

When, in *Civilization and Its Discontents* (1930a), Freud raised the issue of a (collective) cultural superego, he was revisiting his earlier reflections on the origins of civilization in *Totem and Taboo* (1912–1913a). There, evoking the myth of the primal horde, he had associated the killing of the primal father with the prohibition on incest. After investigating the genesis of guilt in *Civilization and Its Discontents*, he attempted, in *Moses and Monotheism* (1939a), to account for the strength of tradition. With the concept of the superego, Freud tackled the thorny subject of what humankind elevates and makes sublime. Strictly opposed to any kind of spiritual approach, which the theme of the conscience readily encouraged, he focused on the concrete development and instinctual aspects of agency.

In seeking to expose the structural dimension of the split between the ego and the superego, Freud based his findings on two pathological phenomena: delusions of observation and manic-depressive psychosis. In delusions of observation, the monitoring and judging internal agency (the superego) is reprojected outward. Manic-depressive psychosis illustrates the cyclic operation of the moral conscience and the changes that occur in the relationship between the ego and the superego: in melancholic self-reproach, the superego persecutes the ego, and in manic euphoria, the ego and its ideal coincide (as in the ritual festivity of a carnival).

From the ontogenetic viewpoint, the superego is "heir to the Oedipus complex." This means that the advent of the superego prolongs the core affective relationships of childhood by rendering permanent the conditions that brought about its establishment. The identifications that constitute the superego are the bearers at once of parental prohibitions and of instinctual cathexes relating to the parents as objects, cathexes that these identifications replace according to a regressive logic in which the wish to be like dislodges the wish to have (Freud, 1933a, p. 63). Broadly speaking, the identifications of the superego owe their autonomy, their constraining role vis-à-vis the ego, to the

child's crucial dependence on its objects. "At the beginning . . . what is bad is whatever causes one to be threatened with loss of love" (Freud, 1930a, p. 124). If establishing the superego through identifications has far-reaching consequences, this is because the relationship of the ego to the superego reproduces the relationship of the child to the all-powerful parents. Real anxiety related to the parents is transformed into moral anxiety arising from the tension between the ego and a superego that draws no distinction between the wish and the act. The superego first appears, therefore, as the upshot of a regressive defensive process that tends to lend permanence in mental reality to a world determined above all by parental desire and parental protection. Freud conceived of religious belief as underpinned by a projection outward of the child's superego, motivated by a nostalgia for the father. This helps explain why the task of the ego during adolescence is to escape from the authority of the superego.

In Freud's detailed metapsychological description of the genesis and development of the superego, the superego begins to form very early on, and this formation involves permanent rearrangements of identifications and changes in their very nature as they become less narcissistic and more symbolic.

There is thus a clear dividing line between a primitive realm of the superego (as described by Melanie Klein) and a distinctly postoedipal realm. The primitive realm is founded on archaic mechanisms (identification with the aggressor and the law of talion [an eye for an eye]). In the postoedipal realm of the superego, a bisexual superego "consisting of these two [paternal and maternal] identifications in some way united with each other" (1923b, p. 34) bears the mark of the subtle mental developments that for Freud are specific to the phallic phase and the "complete" Oedipus complex (love and hate for each parent, identification with both). Under this later configuration, the structuring effects of the castration complex and the integration of the fantasy of the primal scene make it possible for the superego to resolve and protect the ego from what are now incestuous wishes. Successful development of the superego is indicated by the individual's acquisitions of culture during the latency phase and by an ability of the individual to traverse the reactivation of instinctive desires that occurs in adolescence and to achieve autonomy. Progression along these lines correlates with a reduction of the superego's demands to essential social rules alone, with its gradual detachment. Such progres-

sion tends to turn the superego into a more purely symbolic agency. The profoundly paternal character of Freud's superego has been further developed by Jacques Lacan's concept of the Name of the Father. A consequence is the possibility of a more personal ego ideal. All these modifications of the superego depend on the desexualization inherent to the identification process, for desexualization allows a secondary narcissism in which the ability to idealize and sublimate buttress the cathexis of new objects and social bonds.

At the clinical level, making the superego into a mental agency was one of Freud's theoretical responses to the difficult practical problems posed by certain kinds of resistance—needs for punishment, negative therapeutic reactions, moral masochism—that represent diverse expressions of unconscious guilt. Freud observed how the superego had a general propensity for cruelty, for a severity out of all proportion to that of the child's actual upbringing. This was a crucial insight, for it led him to recognize the endogenous, instinctual origin of cruelty and hence to form the hypothesis of the destructive death instincts.

Unconscious guilt was thus seen in essence as turning such destructiveness back against oneself. This explains the paradoxical fact that the superego is made stronger by the renunciations it imposes, and that anxiety is increased even by misdeeds never performed (as witness crimes committed out of a sense of guilt). The narcissistic desexualization involved in the process of identification, upon which the superego is founded, permits a diffusion of instincts whereby the superego tends to become the focus of a liberated death instinct (the "pure culture of the death instinct" seen in melancholia).

By contrast, the proper functioning of the postoedipal superego, which results in a dynamic of conflict between the ego and the superego, presupposes that the environment allows a balanced apportionment of love and discipline that result in a fusion of instinct. The coherent superego that results makes for a tempered guilt capable of underpinning a sense of responsibility in the subject.

JEAN-LUC DONNET

*See also:* Activity/passivity; Agency; Alcoholism; Altruism; Antilibidinal ego/internal saboteur; Anxiety; Castration complex; Censorship; Character; Civilization (*Kultur*); Cruelty; Defense; Depression; Ethics; Fusion/

defusion; Graph of Desire; Guilt, unconscious sense of; Heroic identification; Humor; Id; Ideal Ego; Identification; Imago; *Inhibitions, Symptoms, and Anxiety*; Latency period; Law and psychoanalysis; Libidinal development; Linking, attacks on; Melancholic depression; Oedipus complex, early; “Outline of Psychoanalysis, An”; Prohibition; Psychic apparatus; Psychic causality; Self-hatred; Self-punishment; Unconscious, the.

### **Bibliography**

- Amar, Nicole; Le Goues, Gérard; and Pragier, Georges (Eds.). (1995). *Surmoi II: les développements post-Freudiens*. Paris: Presses Universitaires de France.
- Donnet, Jean-Luc. (1995). *Surmoi I: le concept Freudien et la règle fondamentale*. Paris: Presses Universitaires de France.
- Freud, Sigmund. (1912–1913a). Totem and taboo. *SE*, 13: 1–161.
- . (1914c). On narcissism: an introduction. *SE*, 14: 67–102.
- . (1921c). Group psychology and the analysis of the ego. *SE*, 18: 65–143.
- . (1923b). The ego and the id. *SE*, 19: 1–66.
- . (1930a). Civilization and its discontents. *SE*, 21: 57–145.
- . (1933a). New introductory lectures on psychoanalysis. *SE*, 22: 1–182.
- . (1939a). Moses and monotheism: Three essays. *SE*, 23: 1–137.

### **Further Reading**

- Arlow, Jacob. (1982). Problems of the superego concept. *Psychoanalytic Study of the Child*, 37, 229–244.
- Blum, Hans. (1985). Superego formation, adolescent transformation, and adult neurosis. *Journal of the American Psychoanalytic Association*, 33, 887–910.
- Brenner, Charles. (1982). Concept of the superego: A reformulation. *Psychoanalytic Quarterly*, 51, 501–525.
- Gray, Paul. (1987). On the technique of analysis of the superego: An introduction. *Psychoanalytic Quarterly*, 56, 130–154.
- Hartmann, Heinz, and Loewenstein, Rudolph. (1962). Notes on the superego. *Psychoanalytic Study of the Child*, 17, 42–81.
- Hoffman, Leon, rep. (1998). Panel: The clinical value of the superego concept. *Journal of the American Psychoanalytic Association*, 46, 885–896.

Loewald, Hans W. (1973). Some instinctual manifestations of superego formation. *Annual of Psychoanalysis*, 1, 104–116.

Milrod, David. (2002). The superego: Its formation, structure, and functioning. *Psychoanalytic Study of the Child*, 57, 131–150.

O’Shaughnessy, Edna. (1999). Relating to the superego. *International Journal of Psychoanalysis*, 80, 861–870.

Spitz, Rene. (1958). On the genesis of superego components. *Psychoanalytic Study of the Child*, 13, 375–404.

---

## **SUPERVISED ANALYSIS (CONTROL CASE)**

Control analysis (also known as “supervised analysis” or “analysis under supervision”) is a cure during which the analyst reports back the “material” and progress to an experienced colleague for discussion. Although supervised analysis is a mandatory stage for trainee analysts, it is not exceptional for an analyst to feel the need to discuss a difficult case with an experienced colleague even after the end of the supervised analysis.

The practice dates from the origins of psychoanalysis and we may even consider that it was present when psychoanalysis came into being, because Freud laid down the bases for it in his correspondence with Wilhelm Fleiss and in the course of their periodic “congresses.” He then went on to institute the practice of open discussion with the analysts he trained, enabling them to discuss their cases during the Wednesday meetings of the Psychological Society, later the Vienna Psycho-Analytical Society (cf. *The Minutes of the Vienna Psycho-Analytical Society* 1962, 1967, 1975), and in the course of private conversations. These new analysts themselves continued this practice with their own students.

However, it was quite frequent in those early days for the same person to act as analyst and supervisor within a limited circle. The obvious drawbacks of such a confusion of roles precipitated a call for better regulation of the process. A first directive was adopted during the congress of the International Psychoanalytic Association (IPA) in Bad Homburg, Germany, in 1925. It was agreed that the training process, regulated and supervised by the societies comprising the IPA, or their training institutes, should include at least two supervised analyses, the supervisor being distinct from the analyst. (An earlier congress in 1918 had already

established the necessity of personal analysis for candidates.)

These principles still apply. The IPA rules stipulate that only the body of training analysts of a regional society can authorize supervised analyses; that two adult analyses must be conducted, and that at least one child analysis is desirable in addition; that the supervisors must themselves be accredited by their society; that the supervision must be weekly; and that each of these supervisions must last at least two years (the analysis itself may obviously extend beyond this period).

Those are the general rules. They are compatible with differing approaches depending on the country or psychoanalytic group. In practice, admission to supervised treatment generally coincides with admission to training as a psychoanalyst (including, in addition, lectures, attending work groups, and seminars). Candidates may be admitted following personal interviews with several training analysts whose mission is to assess the state of progress of their personal analysis (whether applicable), as well as their potential as future analysts, and who report back to a commission in charge of making the actual decision. Several IPA societies exclude the candidate's analyst from this procedure (the Paris Psychoanalytic Society preferring to extend this exclusion to all stages of the training process, including final certification).

Supervision can have two formats: the weekly meeting may be personal, limited to the candidate and the supervisor; or a "group meeting," comprising several candidates (but never more than five or six) who may meet with a shared supervisor. Both systems have advantages and drawbacks. It is often stressed that group supervision has the great advantage of enabling candidates to compare their experiences and thus to avoid a too closely dyadic relationship with their supervisor. Individual meetings, on the other hand, facilitate more open discussion, free from the reserve and self-conscious attitudes to be expected in groups; also they facilitate discussion of counter-transference issues, more difficult in a group setting. There is a risk here, however, of reviving and importing transference effects from the candidate's personal analysis (which is often ongoing during supervision).

Generally speaking, the idea in supervisions is not to dictate to trainee analysts what they should do and say, even less to equip them with theoretical precepts

or technical recipes. The aim is to help them detect the meaning of the material that is presented to them, its instinctual and affective charges, as well as the patient's defenses, all this with reference to the transference and counter-transference. This consideration is especially vital to the training of analysts. The supervisor's task is therefore a difficult one, because he or she must draw the attention of the supervised analysts to their own counter-transference without ever transforming the supervision into an analytic session.

The procedure raises many delicate questions, calling for continual work on the part of psychoanalytic institutions (Lebovici, Solnit, 1982). This has led certain groups to work out original formulas, such as the "fourth analysis," proposed by the Quatrième Groupe OPLF (France) as its foundation.

ROGER PERRON

*See also:* "Analysis of a Phobia in a Five-Year-Old Boy" (Little Hans ); Association psychanalytique de France; Berliner Psychoanalytisches Institut; Fourth analysis; Hungarian School; Pass, the; Psychoanalytic filiations; Société psychanalytique de Paris and Institut de psychanalyse de Paris; Training of the psychoanalyst.

### **Bibliography**

- Fleming, Joan, and Benedek, Terese F. (1983). *Psychoanalytic supervision: A method of clinical teaching*. New York : Basic Books.
- Lebovici, Serge, and Solnit, Albert J. (Eds.). (1982). *La formation du psychanalyste*. Paris: Presses Universitaires de France. Monographies de l'Association psychanalytique internationale.
- Nunberg, Hermann, and Federn, Ernst. (1962–1975). *Minutes of the Vienna Psychoanalytic Society*. New York: International Universities Press.

---

## **SUPPRESSION**

Suppression is a defense mechanism aimed specifically at affect, which intends to abolish it from consciousness without allowing its re-entry into the unconscious.

The term "suppression" in its broadest sense was used by Sigmund Freud (1900a) to describe a conscious mechanism intended to eliminate undesirable psychical content from consciousness. The difference between suppression and repression (1915d) lies in the



fact that this latter defense mechanism is unconscious and under its influence repressed content becomes or remains unconscious. Repression is concerned essentially with the “ideational representatives” of the drive/instinct, which are distinct in that they may remain unconscious. In Freud’s early theorizing of affects, though, affects are suppressed and do not pass into the unconscious.

Throughout the metapsychology, however, this distinction between suppression and repression is not quite so clear-cut: “We know, too, that to suppress the development of affect is the true aim of repression and that its work is incomplete if this aim is not achieved” (1915e, p. 178). In this passage from “The Unconscious,” the suppression of affect appears as a specific mode of repression destined to eradicate affect from consciousness. Moreover, in the same essay, Freud devotes a chapter to “unconscious feelings” in which affects begin to find a definite position within the unconscious.

This notion of “unconscious feelings” was progressively elaborated on, and in “The Ego and The Id” (1923b), Freud wrote: where feelings are concerned “the *Pcs.* here drops out—and feelings are either conscious or unconscious” (1923b, p. 23). With the introduction of the second topography the affects described by Freud typically become complexes. An unconscious sense of guilt, anxiety as signal, grief, sorrow, etc., are all affects that are articulated through various fantasies, notably around the loss of the object. The signal of anxiety that the threat of the loss of the mother represents for the child is the paradigmatic example of this new conception of affects associated intimately with fantasies (from Freud’s second theory of anxiety). Since affect and representation are thus considered to be closely imbricated with fantasies, the defense mechanisms relating to affects are not differentiated in any specific way, and as a result the affects themselves are also likely to become unconscious.

Melanie Klein, who had adopted Freud’s second theory of anxiety from the outset, considered affects subject to the same defensive vicissitudes as fantasies. Anxiety, however, very quickly became central to her technique; thus interpretation, for example, inevitably has a bearing on the fantasies of the subject in analysis, when anxiety is at its height. As her theoretical system developed, affects would progressively come to occupy a crucial site in the functioning of mental life (1948). In a conception bound up with the “positions” of the two general modes of organization of psychic life, the

type of anxiety, either paranoid or depressive, constitutes a key concept beside the modality of the object, whether partial or total, and alongside mechanisms of defense, whether psychotic or neurotic.

The type of defense mechanism to which the ego might have recourse is dependent on the intensity of depressive anxieties, revealed through the fantasies that manifest them. When they are too intense—in sorrow, but in guilt above all—they are expressed in fantasies involving the catastrophic destruction of objects. The ego will have to mobilize extreme and even psychotic defense mechanisms. Between these, massive disavowal will attack, very specifically, these depressive affects in order to annihilate and erase them; however, other psychotic defense mechanisms such as splitting, projective identification, or projection also contribute to their eradication. Furthermore, their action will give rise to other affects, notably persecution anxiety. Where depressive anxieties are not too extreme, and in instances where considerable fantasies of injury, of death (and thus of the loss of objects) prevail, more or less intense disavowal permits the alleviation or even the transformation of these anxieties, with the help of obsessive defenses, into their opposite—euphoria. Where depressive anxieties are limited and where fantasies of the loss of the love object and exclusion predominate, the depressive conflictual situation opens up the way to the neurotic problematic and the conflictual affects are repressed.

When the repression of affects, the neurotic defense mechanism *par excellence*, becomes more extensive, its effect seems closer to that of disavowal. The analysis of severe neurotic disorders with serious depressive conflicts reveals the interchange between these two defensive modes in the treatment of the conflictual affects: repression and disavowal. When the repression of conflictual affects is too forceful, the intense pressure on the repressed content towards the internal world of the individual seems to transform those aspects of the external world that arouse or recall these affects into denial.

ALAIN DE MIJOLLA

*See also:* Repression.

### **Bibliography**

- Freud, Sigmund. (1915e). The unconscious. *SE*, 14: 159–204.  
 ———. (1923b). The ego and the id. *SE*, 19: 1–66.

### Further Reading

Werman, D.S. (1983). Suppression as a defense. *Journal of the American Psychoanalytic Association*, 31(S), 405–415.

## SURREALISM AND PSYCHOANALYSIS

Begun as an investigation of poetic images and language, their sources, their nature, and specific features, surrealism is a movement of ideas, of artistic creation and action based explicitly on Freudian discoveries, which were used to develop an original theory of language and creativity. In later years it adopted Hegelian dialectics and Marxist-Leninist historical materialism. The “social and martial cataclysm” (Breton, 1934) provoked a revolt by an entire generation.

The movement was founded in Paris in 1924 by French poet André Breton, with the support of a group of poets and painters. The presence of Max Ernst, from Germany, Man Ray, from the United States, and Joan Miró, a Catalan, gave the group its international flavor. Surrealism’s goal was to “change life” (Arthur Rimbaud) by freeing humanity from the constraints of mental or social censorship as well as economic oppression: “Poetry is made by everyone. Not by one” (Lautréamont).

The project made little sense to Freud, who refused his patronage (Freud to Breton, 1933e [1932]; to Zweig, July 20, 1938 (1960a [1873–1939])). Breton visited Freud in Vienna in 1921 and corresponded with him in 1932 about *The Interpretation of Dreams*. In 1937 he asked him to contribute to a planned anthology (*Trajectoire du rêve*, 1938). Freud answered: “A collection of dreams without their associations, without understanding the circumstances in which someone dreamed, doesn’t mean anything to me, and I have a hard time understanding what it might mean to others” (Breton, 1938, I).

These associations were generally omitted by the surrealists when they narrated their dreams. They appear in André Breton’s *The Communicating Vases* (1932), but there the author, denying the “dream navel” for the sake of Marxist-Leninist materialism, felt he could use them to bring into focus all his dream thoughts. He claimed, contrary to Freud, that the dream was a creator, an instigator to action, and capable of dialectically resolving the contradiction between desire and reality. Surrealism ignored therapy.

There are several periods to the history of surrealism. Its “prehistory” dates from 1916 (Breton discovers Freud) to 1924. This was the period of the review *Littérature* (1919). Together with Breton, a group of young artists invented surrealist techniques intended to liberate the unconscious: automatic writing and drawing, hypnotic sleep, hypnagogic visions, dream narratives, group creation, oral and written games, collage, rubbings, decals, experimental photography and theater. The publication of the first *Surrealist Manifesto* (Breton, 1924) ushered in Surrealism’s formative period. The group had a journal of its own, *La Révolution surréaliste*. “We must be thankful for Freud’s discoveries,” wrote Breton, “the imagination may be on the point of winning back its rights.”

In 1927 André Breton, Louis Aragon, Paul Éluard, and Benjamin Peret joined the Communist Party. Breton did not, however, abandon Freud: “The Surrealism that, as we have seen, has adopted Marxist beliefs does not intend to treat lightly the Freudian critique of ideas” (Breton, 1930). Breton soon quit the Communist Party, which reproached him for his Freudianism. Surrealism embraced cinema (Luis Buñuel), the construction of objects (“Situation surréaliste de l’objet,” Breton, 1935), and produced important works of art in every field.

But in 1930, in his *Second Manifesto of Surrealism*, Breton acknowledged the existence of a profound crisis. The third period of Surrealism was about to begin. A new review was introduced, *Le Surréalisme au service de la Révolution*. In 1930 the review published two articles by the French-American psychoanalyst Jean Frois-Wittmann, in 1933 the Breton-Freud correspondence of 1932, a favorable critique of Jacques Lacan’s doctoral dissertation by René Crevel, and, also by Crevel, an attack on an article in the *Revue française de psychanalyse*. The review also published the first texts by Salvador Dalí, where he developed the idea of “critical-paranoia,” the use of the interpretative processes of paranoia for creative ends, and the exploration of the unconscious.

In 1933 *Minotaure* appeared. Although it was not the official voice of the group, it was strongly influenced by it. The first issue included articles on the “contributions of psychoanalysis.” Lacan and Dalí explained their conceptions of paranoia as an active psychic phenomenon, which Dalí compared with the passivity he associated with dreams and automatic writing. Several large-scale international exhibitions

confirmed the growth of surrealism around the world, a phenomenon that accelerated during the Second World War following the exile of Breton, André Masson, and Max Ernst in the United States, and Benjamin Péret in Mexico, and continued after the war.

Breton, the principal theorist of the group, maintained a close association with Freudian thought throughout his career. He was most interested in the logic of the unconscious, in conflicts between the ego, the id, and the superego, relating them to the process of artistic creation, to Freudian ideas of sexuality, fantasy, desire, repression, the death instinct, whose opposition to Eros he assumed to be dialectical (Breton, 1930), and especially to ideas about representation and perception (Breton, 1933). Beginning with his concept of “pure mental representation,” situated “beyond true perception,” he examined, in the context of the *Essais de psychanalyse* (1927), how the transition from the unconscious to the perception-consciousness system takes place in the creative individual. For Breton, as a reader of Freud, it was at the preconscious level that language and the traces of acoustic and visual perceptions were united and charged with affect. But Breton went further: he saw in these preconscious elements the raw material of creation, obtained by the removal of repression with the help of automatic writing and drawing. In creating a work of art, the artist would make the individual universal (Breton, 1935).

In a letter to Stefan Zweig, Freud, who had met Salvador Dalí in London, also associated the fundamental elements of the work of the artist with the preconscious, but he added a principle of economy: “From the critical point of view it could still be maintained that the notion of art defies expansion as long as the quantitative proportion of unconscious material and preconscious treatment does not remain within definite limits” (July 20, 1938). The specific task of the creative individual, the result of his “initiative” (Breton) is to manipulate the relation between unconscious and preconscious elements, and objectify them in a work of art. Repression would have to be removed using “surrealist techniques” (Breton). Freud’s meeting with Dalí seems to be the only time when Freud made an effort to understand the surrealist use of psychoanalysis and compare it with his own beliefs.

There were other points of contact between surrealism and psychoanalysis: Adrien Borel discussed his

surrealist experiences (1925); Salvador Dalí and René Crevel interviewed Jacques Lacan; Crevel, Antonin Artaud, and Robert Desnos were analyzed by René Allendy, which they later wrote about. André Embircos, a surrealist poet and theoretician as well as a psychoanalyst, founded, together with Marie Bonaparte, the Greek Psychoanalytic Society.

Lacanian thought developed throughout the nineteen-sixties, and, although it has a number of affinities with surrealism, it has always remained distinct. In 1971 the surrealist painter and philosopher René Passeron, with his research team at the C.N.R.S., founded *Études poïétiques*, which analyzed the creative process and made use of Freudian theory. A number of psychoanalysts (André Berge, Jean-Bertrand Pontalis, Guy Rosolato) were interested in the surrealists. As Breton found in 1934, the scope of surrealism, through the upheaval of sensibility it entails, “is socially incalculable.” As a movement it has frequently helped the spread of psychoanalysis.

NICOLE GEBLESCO

*See also:* Breton, André; Choisy, Maryse; Held, René; Lacan, Jacques-Marie Émile; Literature and psychoanalysis.

### **Bibliography**

- Biro, Adam, Passeron, René. (1982). *Dictionnaire général du surréalisme et de ses environs*. Freiberg, Switzerland: Office du Livre.
- Breton, André. (1988). *Œuvres complètes*. Édition établie par Marguerite Bonnet. Paris: Gallimard, La Pléiade.
- Freud, Sigmund. (1927). *Essais de psychanalyse* (Samuel Jankelevitch, Trans.). Paris: Payot.
- . (1960a [1873-1939]). *Letters of Sigmund Freud, 1873-1939* (Ernst L. Freud, Ed.; Tania and James Stern, Trans.). London, Hogarth Press, 1970.
- Hulak, Fabienne, and Bonnet, Marguerite. (1992). *Folie et psychanalyse dans l'expérience surréaliste*. Nice: Z'Éditions.
- Mélusine. (1992). *Cahiers du Centre de recherches sur le surréalisme, XIII, Le surréaliste et son psy*. Paris.
- Revue surréalistes* (1919–1939); *Littérature* (1919–1921, 1922–1924); *La Révolution surréaliste* (1924–1929); *Le Surréalisme au service de la Révolution* (1930–1933); *Minotaure* (1930–1933, 1933–1939). Paris: Jean-Michel Place, 1975, 1976, 1981.

## SWEDEN

Toward the end of the nineteenth century, the Swedish writer August Strindberg, wrote several plays, novels, and short stories dealing in a pertinent fashion with religion and doubt, the relations between men and women, the father and his position in the family. He described the hypocrisy and the destructive forces, the unconscious motivations, the representations and specific conflicts of man at the turn of the century. In 1893 the name of his contemporary, Sigmund Freud, was mentioned in Sweden for the first time in a medical review, along with those of Josef Breuer, Pierre Janet, and Jean Martin Charcot. The article, dealing with traumatic neuroses, was written by Frithiof Lennmalm, a professor of nervous pathology.

Freud wrote *On the History of the Psychoanalytic Movement* in 1914. Nine years later, in 1923, he felt obliged to specify in a note: "At the present time the Scandinavian countries are still the least receptive."

Psychoanalysis was introduced to Sweden in a manner that was at least unique. The two pioneers, Emanuel af Geijerstam, installed in Göteborg from 1898 to 1928, and Poul Bjerre, who worked in Stockholm and its surroundings for almost half a century, shared a similar attitude: they were both interested in psychoanalysis but were keenly critical of it. Geijerstam, a researcher and psychotherapist, approved of the theses of Alfred Adler and Carl Gustav Jung, without however being hostile to psychoanalysis. He wrote about Freud in 1902 but, from 1916 until his death, he persistently stressed that "anagogic analysis" constituted a progression on Freudian psychoanalysis. And when Geijerstam went on a study trip it was not to Vienna but to Zurich.

Poul Bjerre met Freud in December 1910. At a conference of the Swedish medical association the following year he introduced a part of Freudian theory. He went on to translate and in 1924 to publish some articles by Freud. From the time of his first encounter with the founder of psychoanalysis, and particularly after 1912, he was convinced that his own work was more important. For Bjerre, Freud had become bogged down in a mechanistic science that specifically prevented him from understanding the scope of psychosynthesis. Thus, for thirty years Freud was represented in Sweden by two physicians specializing in nervous diseases, having different points of view,

but who shared their refusal to take on board the totality of Freud's theory.

In the bulletins of the Swedish medical association we find criticism of Freud as early as 1910. The tone was set by two eminent physicians, Bror Gadelius (1862–1938) and Olof Kinberg (1873–1960). Gadelius, a psychiatrist, adopted the following stance: "Freud has overestimated the importance of sexuality; this is because of the nature of his clientele who, in a cosmopolitan city like Vienna, have a particular propensity for exaggeration. We cannot never overstress the fact that alongside the sexual complexes—whose role in the appearance of hysteria I in no way wish to underestimate—there exist other complexes charged with affect that can give birth to neuroses and hysteria, and how much these complexes go hand in hand with the "*Ich Triebe* [ego-instincts]." However, this point of view did not prevent Gadelius from acknowledging the merits of Freud's theory. In his important work on psychiatry, *Det mänskliga Själsivet* (The Human Soul), he specifically wrote that "in recent years, largely thanks to Freud and his school, much more attention has been accorded than previously to the importance of the sexual instinct in psychic life." To sum up, Geijerstam and Bjerre, who are generally considered to have introduced psychoanalysis to Sweden, and Gadelius, the greatest critic and opponent of the discipline, adopted a similar position.

Simultaneous with the growing interest in psychoanalysis in Sweden at the end of the 1920s, we find the increasing hostility of several influential physicians and academics. This resistance had already made its appearance in 1911 when Poul Bjerre tried to publish his conference, "The Psychoanalytic Method," in which he gave the most positive presentation of psychoanalysis and met with what he considered to be unjustified criticism. Presentations delivered within the framework of the Swedish medical association were normally published in the review *Hygiea*. Bjerre's was refused on the pretext that it was too long. In addition, Gadelius indulged in a methodical criticism of psychoanalysis in his work *Tro och helbräddagörelse. Jämte en kritisk studie av psykoanalysen* (Faith and Healing. A Critical Study of Psychoanalysis), published in 1934.

The review *Clarté*, which had socialist leanings, was a branch of the international Clarté movement and acted as a platform for psychoanalysis. In the latter

half of the twenties it published the texts of the Swedish pioneers of Freudianism. A few intellectuals believed that psychoanalysis could perhaps be used to formulate a radical theory of society. Interest in psychoanalysis was essentially linked to this aspect and was marked by its pragmatism. In the thirties literary circles little by little began to take an interest in psychoanalysis. This interest took many forms, including the creation of the review *Spektrum*, which published modernist poetry and translations of psychoanalysts like Anna Freud, Erich Fromm, and Wilhelm Reich. One of the Swedish pioneers, Per Henrik Törngren, who went into analysis with Ludwig Jekels a few years later, was part of the editing committee and published his own texts in the review. During this same period Sweden saw the publication of considerable extracts from *The Interpretation of Dreams*, as well as, in their entirety, *The Future of an Illusion* and *Civilization and Its Discontents*.

In August 1931 the pioneers of psychoanalysis in the Scandinavian countries met to discuss for the first time the formation of a psychoanalytic society. Among the participants were Sigurd Naesgaard, a Dane; Harald Schjelderup, a Norwegian; Vriö Kulovesi, a Finn, and Alfhild Tamm, a Swede. Tamm, who organized the meeting, had international experience and had been a member since 1926 of the Vienna Psychoanalytic Society. The Scandinavian group then split into two societies, a Danish-Norwegian society and a Finnish-Swedish society, for which she became the spokesperson. Tamm was the first woman psychiatrist in Sweden. Her theoretical work was of minimal importance. She invoked the tradition of the Enlightenment to combat prejudice with regard to masturbation and sought to understand the mechanisms of aphasia. Tamm was too much on her own for the first ten years to enable the society to become influential and the activities of the pioneers of psychoanalysis were somewhat limited.

The early thirties saw the arrival in Scandinavian countries of psychoanalysts who had been trained in Central Europe, particularly Vienna and Berlin. The Viennese Ludwig Jekels, a student of Freud's, settled in Sweden from 1934 to 1937. He saw his work as a training analyst in Stockholm as a difficult and thankless task and he finally left Sweden with the feeling that he had failed in his mission. As was common at the time, some Nordic pioneers made the journey to Vienna, Berlin, or Zurich to be analyzed by August Aichhorn,

Helene Deutsch, Paul Federn, Eduard Hitschmann, Oskar Pfister, or Harald Schultz-Hencke.

The Nordic psychoanalysts were looking for more competent colleagues than themselves who would be capable of training them, and from 1926 onward they began to organize themselves along the lines of the model fixed by the International Psychoanalytic Association (IPA). Scandinavian countries simultaneously witnessed the creation of new psychotherapy societies based on an eclectic concept of psychotherapy and the exclusion of some of the bases of psychoanalysis, such as the theory of infantile sexuality and dream theory.

In 1932 Norway saw the formation of the Nordisk Psykoanalytisk Samfund (Nordic Psychoanalytic Society) under the presidency of Alfhild Tamm with, among its most notable members, Poul Bjerre and Sugurd Naesgaard. In Denmark the Psykoanalytisk Samfund was founded in December 1933, with Swedish Poul Bjerre, Danish Sigurd Naesgaard, and Norwegian Irgens Stromme playing the leading roles.

During World War II the Dutch psychoanalyst René de Moncy, a personal friend of Freud, went to live in Sweden as a result of his encounter in Vienna with the Jewish Swedish psychoanalyst Vera Palmstierna, who had been in analysis with Freud. The couple settled in Stockholm. René de Moncy had played a major role in the Dutch Society and was to play an equally important role in Sweden during the eight years that he lived there. He was psychoanalyst to Ola Andersson (1919–1990) and the Hungarian psychologist Lajos Székely (1904–1995) who was practicing in Sweden. Székely was a Jewish émigré who had arrived in 1944 with his wife Edith, a physician and psychoanalyst. He had trained as an analyst firstly in Hungary, then in Germany and Holland during the 1930s, and finally in Sweden. He was to play a major role in the 1950s by providing analytic training for Swedish physicians and psychologists. He wrote on a variety of subjects, among them the links between the unconscious and creativity. Székely spoke several languages and published articles in English, French, Swedish, German, and Hungarian.

Stefi Pedersen (1908–1980) began her analytic training in the Berlin Psychoanalytic Institute. She was first analyzed by Otto Fenichel in Berlin and later joined him in Oslo. In Sweden—where she arrived with a group of Jewish children after a stay in Norway—she worked in the Swedish Psychoanalytic

Society (Svenska Psykoanalytiska Föreningen). She did a second analysis, this time as trainee, with René de Monchy. Her status as a member of the Society did not prevent her from adopting an independent and critical position. She was rather radical in her thinking and was attracted by Alexander Mitscherlich's theses. She wrote articles on vulnerability and the effects of the Nazi terror on psychoanalysts and clinical work. She published texts in English, German, Norwegian, and Swedish.

In August 1943, Tore Ekman (1887–1971) returned to Sweden after practicing for nearly twenty years in Berlin and Leipzig, as well as working as “*Lektor*” in Leipzig University. He trained under Therese Benedek, a close friend of Alfhild Tamm, and went on to play a role of capital importance in the Swedish Psychoanalytic Society, although he published very little. The psychoanalyst and theorist of science, Carl Lesche (1920–1993), a Finnish émigré in Sweden in the early 1950s, was also to occupy an important position in the Swedish Society between the 1960s and the 1980s. Among his influences were philosophers Wilhelm Dilthey, Edmund Husserl, and Karl-Otto Apel. The question of the classification of psychoanalysis was to take on a new dimension with him. He claimed that it was essential to define what made psychoanalysis more of a hermeneutic discipline than a natural science and to point out where it differed from psychotherapy. However, the influence of Lesche has not extended beyond the borders of Sweden.

Swedish psychoanalysts have done little research work and have made few important contributions to the history and theory of psychoanalysis. Ola Andersson's thesis, “Freud before Freud. The Prehistory of Psychoanalysis” (1962) constitutes a remarkable exception, as does academic Gunnar Brandell's more substantial essay, “Freud a Child of his Century” (1961). Ola Andersson wrote an in-depth study of the context in the history of ideas that saw the birth and evolution of Freud's thinking up to 1896, the time when he formulated the concept of psychoanalysis. Andersson stressed the importance of the influence of Herbart on Freud and conducted original research into the true identity of Emmy von N. Andersson and Brandell. Both took part in Uppsala University seminars conducted by Wilhelm Sjöstrand, a pedagogue and history enthusiast who organized seminars at the end of the 1950s, during the time Michel Foucault was teaching at this university.

Few psychoanalysts in Sweden have taken an interest in philosophy, the theory of science, or the history of ideas, just as few Swedish philosophers and academics have studied Freudian theory, with one exception: researchers in the psychology department of Lund University have taken an interest in psychoanalysis since the 1940s.

The Swedish Psychoanalytic Society now numbers more than one hundred and ninety members and there is ever growing interest in its training program. Toward the middle of the 1960s, voices were nevertheless raised in criticism of this training. In 1963 one of the society's psychoanalysts, Margit Norell, secretary to the training group, founded a work group with some of the analysts. This work resulted in 1968 in the formal creation of the Swedish Society for Holistic Psychotherapy and Psychoanalysis (SSHPP), which joined the International Federation of Psychoanalytic Societies (IFPS) in 1972. The SSHPP was initially supported by neo-Freudians, Erich Fromm, Frieda Fromm-Reichmann, and Harry Stack Sullivan. Harold Kelman, an American closely allied with Karen Horney, greatly contributed to its development. He organized seminars and was thesis director for many teachers. Toward the end of the 1970s, the SSHPP took an increasing interest in the theory of object relations, particularly in the work of theoreticians like Melanie Klein, Ronald Fairbairn, Donald Winnicott, and even Wilfred Bion. This same period saw intensified relations between the Swedish Psychoanalytic Society and the Swedish Society for Holistic Psychotherapy and Psychoanalysis, which began to study Freud more than ever. In May 1992 it was decided in agreement with the majority of the members to request affiliation with the IPA. Since then the IPA has never ceased to grow and it now numbers about seventy-five members.

In the 1970s, Swedes began to take an interest in Jacques Lacan and French psychoanalysis. This interest coincided with the publication in Swedish of the works of the French structuralists. A first translation of Lacan's work appeared, entitled *Écrits*, but containing less than 15 percent of the French edition of *Écrits*, and was followed by pirate publications of other translations of texts by Lacan. Inspired by Lacan's work, a few rare researchers in human sciences were seduced by the idea of establishing links between psychoanalysis and modern linguistics. For a short period during the 1970s and 1980s, psychoanalysts from South America and the United States trained psychologists and physicians at

Göteborg. In 1974 the Göteborg Institute for Psychotherapy (Göteborg Psykoterapi Institut) was founded, its founders, the Argentinean psychoanalysts Angel and Dora Fiasché, having been trained in their own country by the IPA. Dora Fiasché is a philosopher and still a member of the IPA. Angel Fiasché is a physician and has since left the IPA. The Fiaschés, who consider themselves to be socialists, are close to Kleinian psychoanalysis in terms of theory. They have worked with, among others, León Grinberg, Maria Langer, and Enrique Pichon-Rivière. They regularly return to Göteborg and several members of the Institute have been to Buenos Aires for professional reasons. In terms of its orientation the Göteborg Institute for Psychotherapy is eclectic and pragmatic and adopts a radical position on social questions. It now has more than forty members. Just as in Göteborg, the interest in the theoretical works of Melanie Klein has also increased elsewhere.

In Sweden the dawn of the twenty-first century has seen renewed criticism of psychoanalysis, coming in equal parts from academic psychology and biological psychiatry. This has not prevented psychoanalysts and researchers from all quarters from taking part in a joint project: the publication in Swedish by a major publishing house of the complete works of Sigmund Freud. In 2002, the review *Psykoanalytisk tid/Skrift* began publication in Göteborg; it is mainly orientated toward French psychoanalysis and thought.

PER MAGNUS JOHANSSON, DAVID TITELMAN

### Bibliography

- Gadelius, Bror. (1934). *Tro och helbräddagörelse jämte en kritisk studie av psykoanalysen*. Stockholm: Hugo Gebers.
- Johansson, Per Magnus. (1999). *Freuds psykoanalys, utgångspunkter/arvtagare i Sverige*. Göteborg: Daidalos.
- (2003). *Freuds psykoanalys, arvtagare i Sverige*. Göteborg: Daidalos.
- Luttenberger, Franz. (1989). *Freud i Sverige*. Stockholm: Carlsson Bokförlag.
- Törngren, Pehr Henrik. (1936). *Striden om Freud*. Stockholm: Albert Bonniers Förlag.

---

## SWISS PSYCHOANALYTIC SOCIETY

See *Schweizerische Ärztegesellschaft für psychoanalyse*

---

## SWITZERLAND (FRENCH-SPEAKING)

Freud's ideas found their first echo in Geneva, a psychological milieu infused with scientific tradition and thus offering a more favorable reception in French-speaking Switzerland than in France. As early as 1900 Théodore Flournoy and his student and successor Édouard Claparède, professors of psychology in the science faculty of the University of Geneva, enthusiastically welcomed these new ideas and contributed to spreading them.

The psychoanalytic movement began in French-speaking Switzerland in the 1920s when the first French-speaking psychoanalysts joined the *Société suisse de psychanalyse* (Swiss Psychoanalytic Society), founded in Zurich on March 24, 1919, by Emil and Mira Oberholzer and Oskar Pfister. At approximately the same time, in September 1920, physician and non-physician psychoanalysts created the Geneva Psychoanalytic Society. This short-lived society, which was never enrolled with the International Psychoanalytical Association, disappeared at the end of the 1920s.

During the first period (1919–1952), the first psychoanalysts, for example, Charles Odier and Raymond de Saussure, worked to make Freud's ideas known not only in French-speaking Switzerland but also in Paris, where they helped found the *Société psychanalytique de Paris* (Paris Psychoanalytic Society), the *Revue française de psychanalyse*, and the *Conférence des psychanalystes de langue française* (Conference of French-Speaking Psychoanalysts). During the 1920s contacts with Swiss German psychoanalysts were rare, but came to be strengthened after the departure of the Oberholzer group in 1928 and under the presidency of Philipp Sarasin, who instituted the Swiss society's teaching commission. Psychoanalytic life in Geneva was initially dominated by Henri Flournoy, Charles Odier, and Raymond de Saussure, along with Charles Baudouin, who later founded his own school of psychoanalysis. Henri Flournoy (1886–1955), physician and psychoanalyst and son of Théodore Flournoy, trained with Johan H. W. Van Ophuijsen in Holland, then with Freud and Hermann Nunberg in Vienna. His teaching played an important role, and along with Odier, he introduced training analysis to French-speaking Switzerland. Odier set up in Paris in 1922, and Saussure followed suit in 1937. Marguerite A. Sechehaye (1887–1964) developed symbolic realization, a method of psychoanalytic therapy for schizophrenics.

Prior to the Second World War, psychoanalysis began to spread through French-speaking Switzerland outside of Geneva. In the Valais canton its development was linked to Dr. André Repond (1886–1973), director of the Hôpital de Malévoz psychiatric clinic, as well as Dr. Norbert Benoziglio and Germaine Guex, who helped create the first psychoanalytically informed medical-psychological consultations. The outbreak of World War II saw the return of Odier to Switzerland to settle in Lausanne, whereas Saussure left for the United States in 1940, where he remained until 1952.

As soon as he returned to Geneva in 1952, Saussure gave a distinct impetus to psychoanalysis in French-speaking Switzerland by organizing training. In Geneva he was assisted by Michel Gressot, physician and psychoanalyst, then in 1956 by Marcelle Spira, a Swiss psychoanalyst trained in the Melanie Klein school in Argentina, and in Lausanne he was assisted by Germaine Guex, Marcel Roth (1911–1992), Etiennette Roch-Meyerhof (1914–1989), and Madeleine Rambert (1900–1973), child psychoanalyst. These psychoanalysts had a lasting influence by virtue of their scientific accomplishments and the training they provided for many psychoanalysts from various parts of the world. They were later joined in Geneva by Olivier Flournoy, son of Henri, who trained in Paris and the United States, and in Lausanne by René Henny, child and adult psychoanalyst and professor of child psychiatry, and by Christian Müller and Pierre-Bernard Schneider, who were psychoanalysts and directors of psychiatric institutions. René A. Spitz stayed in Geneva for six years during the 1960s and contributed to training there. Julian de Ajuriaguerra, director of the psychiatric institutions at the University of Geneva from 1959 to 1973, and René Diatkine, on regular visits from Paris, also stimulated the development of child and adult psychoanalysis. In the Tessin canton, the Swiss Italian region under the authority of the teaching commission of French-speaking Switzerland, Pier Mario Masciangelo organized psychoanalytic training from 1959 onward.

The Centre Raymond de Saussure (Raymond de Saussure Center) was inaugurated in Geneva in 1973. This equipped French-speaking Switzerland with premises specifically for psychoanalytic seminars, conferences, and a library. Prior to that, meetings were organized in university psychiatric institutions. From this point onward psychoanalysis developed considerably, particularly in Geneva, around Janice

de Saussure, Raymond's wife, an active member and vice president of the International Psychoanalytical Association, as well as around Marcelle Spira, Olivier Flournoy, and Claire Degoumois. In Lausanne psychoanalysis developed around Marcel Roch, Étienne Roch, and René Henny. In the 1990s there were too many French-speaking Swiss training analysts to mention them all, yet it may be helpful to cite those who have made names for themselves through their psychoanalytic publications. Some of them practice as psychoanalysts while occupying positions in university psychiatric institutions for adults, like André Haynal and Antonio Andreoli; in institutions for children, like Bertrand Cramer, Juan Manzano, and Paco Palacio; and in institutions for adolescents, like François Ladame. Others engage mainly in private psychoanalytic practice, like Georges Abraham, Graziella Nicolaïdis, Nicos Nicolaïdis, Danièle Quinidoz, and Jean-Michel Quinodoz, all based in Geneva. Psychoanalysis in Switzerland is characterized by pluralism, a fact reflected in the variety of schools of thought, French-speaking psychoanalysts being influenced by French psychoanalysis, as well as British, mainly Kleinian, psychoanalysis, and German-speaking analysts being influenced mainly by ego psychology.

Psychoanalytic institutions have adopted a federalist structure that reflects Swiss trilingualism (German, French, and Italian) and its cultural diversity. For this reason the activities of psychoanalysts in French-speaking Switzerland are centered around institutions that are both national (monthly meetings of the Société suisse de psychanalyse with simultaneous translations, generally held in Berne) and regional (meetings in the Centre Raymond de Saussure in Geneva). Daisy de Saugy, historian and psychoanalyst, is responsible for keeping the archives.

The entirely bilingual German-French *Bulletin de la Société suisse de psychanalyse* appeared from 1965 to 1969 and then appeared regularly twice a year from 1979 onward.

In French-speaking Switzerland other trends now claim to represent psychoanalysis, but their practice and technique is closer to psychotherapy than to the psychoanalysis instituted by Freud. Geneva has a Charles Baudouin center for psychoanalysis and psychotherapy, as well as a Jungian group, and a Freudian study group unites Lacanians around Mario and Mireille Cifali in Geneva and around François Ansermet



in Lausanne. This group has published the journal *Le Bloc—Notes de la psychanalyse* since 1980.

JEAN-MICHEL QUINODOZ

### Bibliography

- Ellenberger, Henri F. (1952). La psychiatrie suisse. *Évolution psychiatrique*, 17, 139–158, 719–723.
- Meerwein, Fritz. (1979). Reflexionen zur geschichte der Schweizerischen gesellschaft für psychoanalyse in der deutschen Schweiz. *Bulletin de la Société suisse de psychanalySE*, 9, 25–40. (With French translation: Réflexions sur l'histoire de la Société suisse de psychanalyse en Suisse alémanique.)
- Roch, Marcel. (1980). Á propos de l'histoire de la psychanalyse en Suisse romande. *Bulletin de la Société suisse de psychanalySE*, 10, 17–30.
- Saussure, Raymond de. (1967–1968). L'histoire de la psychanalyse en Suisse romande. *Bulletin de la Société suisse de psychanalySE*, 6, 1–4.

## SWITZERLAND (GERMAN-SPEAKING)

Switzerland was the first country, and Zurich and Geneva the first cities outside of Vienna, where psychoanalysis found a corresponding echo. From Zurich it went on to find its way into academic psychiatry, which developed modern psychodynamic psychiatry. As elsewhere, German-speaking Switzerland had its rifts and defections. Some particularities of the country helped contribute to this evolution: Switzerland is a federation of small states (cantons) professing different religions, speaking different languages, and asserting their own autonomy. Individualism and particularities, alongside tendencies toward pragmatic egalitarianism, are part of the national tradition. There are also great class differences.

The two psychiatrists from Freud's generation who paved the way for the introduction of psychoanalysis in Switzerland represent this tradition in a particular manner: Auguste Forel (1848–1931), a French-speaking Swiss who directed the Burghölzli university asylum in Zurich, and his successor from 1898, Eugen Bleuler (1857–1939). They were both close to the patients through daily contact and were socially very committed. Forel devoted a lot of time to hypnosis and sexual education, but kept his distance from psychoanalysis, while Bleuler greeted Freud's book on

aphasia (1891b) with enthusiasm and recognized the global significance of *Studies on Hysteria* (1895d). "My personal experience with schizophrenics confirmed Freud is right, much to my surprise," he wrote in 1910, when successfully defending psychoanalysis against attacks from every quarter. His book on schizophrenia (1911) is influenced by psychoanalysis and in 1901 he encouraged his new assistant, Carl Gustav Jung (1875–1961), to study *The Interpretation of Dreams* (1900a), which had just been published, and to apply the "test of free association" to patients suffering from dementia praecox. Psychoanalysis thus acquired new certainties and Jung met Freud in 1907. Led by Jung, a group of his young colleagues, among them Franz Riklin, Alphonse Maeder, Johann Jakob Honegger, and Ludwig Binswanger, were fired with enthusiasm for psychoanalysis. "The nucleus of the small band who were fighting for the recognition of analysis," as Freud described it (1914d), consisted of foreigners who were attracted by the worldwide reputation of Bleuler's clinic and who came there to train. This was the case of Karl Abraham, Max Eitingon, Hermann Nunberg, Johan H. W. Van Ophuijsen, Abraham A. Brill, Sabina Spielrein, and many more. The essential contribution of the Zurich group consisted of its in-depth research into the psychoses. In Jung, Freud found an expert partner who was gifted with a creative imagination and interested in the history of cultures and religions. The publication of the five volumes of the *Jahrbuch* between 1909 and 1913, the creation of a psychoanalytic association in Zurich in 1907 and its transformation into a regional group of the International Psychoanalytic Association (IPA), founded in 1910, were very largely due to Jung's exuberant activity.

In 1908 the Zurich pastor Oskar Pfister discovered the extent to which psychoanalysis could contribute to spiritual directorship and teaching. He became a zealous propagator, especially in teaching circles, for example with Ernst Schneider, director of a seminary, and his student Hans Zulliger in Bern, whereas theologian Paul Häberlin, a pedagogue and an influential professor of philosophy, came into contact with psychoanalysis through Ludwig Binswanger.

This whole flowering was quickly swept away by the split between Jung and Freud in 1913, when the majority of the Swiss followed Jung. The theoretical differences centered around Jung's "dilution" of the theory of the libido, but the difficulty of the Swiss in separating themselves from the outside world through

principles also had a role to play in it. “Jung was Freud’s great disciple who tried by diplomatic means to reconcile the world to psychoanalysis,” as L. Marcuse wrote with much insight (1956).

The Swiss Psychoanalytic Society (SGPsa) was founded in Zurich on March 21, 1919, and still exists to this day. Pioneering member Oskar Pfister worked there with younger colleagues such as Emil Oberholzer and his wife Mira Gincburg, Hermann Rorschach, Hans Zulliger, and many more. What changed was the growing professionalism; candidates were progressively required to have really experienced analysis. Eminent members like Ernst Blum (Bern), Philipp Sarasin (Basel), Henri Flournoy, Charles Odier, Raymond de Saussure (Geneva), and the two Oberholzers (Zurich) had been analyzed by Freud himself. This fact had a stabilizing and unifying influence until the middle of the twentieth century. But conflict grew rapidly; it was triggered by technical questions, such as short analyses without elaboration of the transference and resistance, a technique introduced by Oskar Pfister in the heroic period.

Emil Oberholzer, the president, hit on a summary solution in 1928 by founding a new society, the Schweizerische Ärztgesellschaft für Psychoanalyse (Swiss Medical Society for Psychoanalysis), from which “lay” members, like Oskar Pfister, were automatically excluded, but also Zulliger. The IPA did not recognize his group and after a few years it had no more than a token existence.

With fewer members (forty members in 1927, five of them residents of French-speaking Switzerland, thirty-three members in 1929) the SGPsa enjoyed a peaceful existence until 1961 under the judicious presidency of Philipp Sarasin. Training requirements and conditions of membership had become stricter. The SGPsa did not have many representation activities, but some of its members were known for their publications and local actions that helped spread psychoanalysis. Basel became particularly important when Heinrich Meng moved there from Frankfurt and was appointed professor of “psychic hygiene” at the university. In a collection devoted to this subject he published not only his own works, but also important works by members of the SGPsa, for example, Rudolf Brun’s *General Treatise on the Neuroses* in 1942 and, in 1944, *Trieb und Kultur* (Instinct and Culture) by Hans Christoffel, a native of Basel. This collection enabled the representatives of the different trends in the intense

intellectual life of Basel to familiarize themselves with the treasures of psychoanalytic thought. The first edition of Oskar Pfister’s work, *Das Christentum und die Angst* (Christianity and Fear) appeared in 1944.

A new split appeared after World War II with the creation of “*Daseinsanalyse*” (“existential analysis”; Ludwig Binswanger and Maeder Boss), an attempt to base psychoanalysis on the philosophy of Husserl and Heidegger. A few analysts, who generally remained true to Freud, found elements there, for example, Gustav Bally and Ernst Blum. Rudolf Brun, of Zurich, violently opposed his strictly biological approach to this trend. But the real split took place in Germany with Alexander Mitscherlich in relation to a clinical case (1950).

In the meantime, the next generation, the “descendants of Freud,” were actively engaged with two of Brun’s students: Paul Parin (born in 1916) and Fritz Morgenthaler (1919–1984). Parin (1949) appealed for greater consideration for the social criticism function of psychoanalysis, and Morgenthaler (1951) illustrated by means of a case history his virtuosity at picking up on unconscious intentions. Both of them represented a renewal of analytic thinking with the same unusual intensity and radicalism that we can also detect in their work in ethnopsychanalysis (1963, 1971). For two decades they represented the center of gravity of psychoanalysis in German-speaking Switzerland. They were relentless guardians of the SGPsa training institute until, in the wake of May 1968, they demanded greater participation for candidates at the Zurich seminar of the SGPsa. As a result of the activism of extreme-left candidates this led, after long discussions in 1977, to the secession of the Zurich Psychoanalytic Seminar (PSZ), which declared itself autonomous and in which members became psychoanalysts upon their own authorization. For this reason, and also because an eminent group of analysts, primarily Parin and Morgenthaler, declared themselves in sympathy with the PSZ, there was a massive influx of analysts (about eight hundred participants in the eighties with a delegation at Bern and branches in Germany [cf. *Luzifer-Amor*, 1993]).

The SGPsa had to be reconstituted in 1977 as the Freud-Institut Zürich. The situation stabilized again, and the Basel and Bern groups, which were growing in importance, played a major role in this. One consequence of the crisis, however, is that psychoanalysis in Switzerland is, as of 2004, mainly concentrated in the

French-speaking part of the country. As of 2003 lists members in the SGPsa. In 2004 there were 45 training analysts who bore the main responsibility for passing psychoanalysis along to Swiss students. Twenty-seven of them worked in Francophone Switzerland (including a few in the Italian-speaking parts); 18 worked in the German-speaking areas.

KASPAR WEBER

### Bibliography

- Bleuler, Eugen (1910). Die psychoanalyse Freuds. Verteidigung und kritische Bemerkungen. *Jahrbuch für psychoanalytische und psychopathologische Forschungen*, 2, 623–730.
- Meerwein, Fritz (1979). Reflexionen zur geschichte der Schweizerischen gesellschaft für psychoanalyse in der deutschen Schweiz. (With French translation: Réflexions sur l'histoire de la Société suisse de psychanalyse en Suisse alémanique). *Bulletin de la Société suisse de psychanalyse* SE, 9, 25–40.
- Moser, Alexander (1992). Psychoanalysis in Switzerland. In Paul Kutter (Ed.), *Psychoanalysis international, a guide to psychoanalysis throughout the world* (Vol. 1, Europe). Stuttgart-Bad Cannstatt: Frommann-Holzboog.
- Walser, Hans H. (1976). Psychoanalyse in der Schweiz. In D. Eicke (Ed.): *Die psychologie des 20. jahrhunderts* (Vol. 2, pp. 1192–1218) Zürich: Kindler.

## SWOBODA, HERMANN (1873–1963)

Hermann Swoboda, professor of law and philosophy, was born on November 23, 1873, in Vienna, where he died on June 18, 1963. The son of a pharmacist, he attended the University of Vienna, where he also spent his career. After receiving a doctorate in law in 1897 and in philosophy in 1901, Swoboda was appointed privatdocent in psychology four years later. He was named professor extraordinarius (full professor without chair) in 1925. By his wife, Marie Felgel von Farmholz, he had three children. Passionate about music, Swoboda became intrigued with studies of the periodic rhythms in human life. He seems to have experienced financial difficulties during the course of his career. His last publication dates to 1940.

Swoboda's encounter with psychoanalysis was short but explosive. In correspondence with Otto Weininger

from 1899 to 1902, he exchanged numerous ideas that helped Weininger to develop his monograph *Sex and character* (1906), published in German in 1903. Several years after Weininger's suicide in 1903, Swoboda wrote a book about his friend, *Otto Weiningers Tod* (The death of Otto Weininger), published in 1911. Meanwhile, in 1900 Swoboda began an analysis with Freud that lasted only a few months. During one of their sessions, Swoboda remarked on contrasting fantasies of "overcoming" and "succumbing," as he later explained, "now *incubus*, now *succubus* toward the events." Freud explained the contrast by reference to the "bisexual disposition of each human" (Swoboda 1906, p. 7; quoted in Schröter, p. 151). Swoboda immediately conveyed this information to Weininger, who incorporated it into *Sex and Character*.

This chain of events would become one of the arguments by which, in 1906, Wilhelm Fliess accused Freud of having transmitted ideas to those he characterized as plagiarists of his work: Weininger (on bisexuality) and Swoboda (on periodicity). In addition, in August 1901 Swoboda advised Weininger to visit Freud to seek his help in finding a publisher for his manuscript. In 1904 Swoboda published *Die Perioden des menschlichen Organismus* (Periodicity in the life of the human organism) and sent a copy to Fliess, who at the time received it with pleasure. (Extracts can be found in Porge, 1994.) Only after reading *Sex and Character* and learning from Freud that Swoboda was his pupil did Fliess initiate accusations of plagiarism. Swoboda reacted by suing for defamation and lost; he also published the pamphlet *Die gemeinnützige Forschung und der eigennützige Forscher* (Research of interest to the public and the researcher's own self-interest; 1906). (Again, extracts can be found in Porge, 1994.)

In *Die Perioden* Swoboda presents his psychological experiments on the spontaneous recurrence of memory representations after 18-hour, 23-hour, and 23-day periods. He included an adulatory chapter on Fliess's work but did not mention Freud's *Interpretation of Dreams* (1900a). These works stand against Wundt's associative psychology. In 1917, in *Siebenjahr* (Septenary periods), Swoboda suggested that there are seven-year rhythms. Freud discusses Swoboda's theses in the revised editions of *The Interpretation of Dreams*.

ERIK PORGE

See also: Fliess, Wilhelm; *Sex and Character*; Weininger, Otto.

### Bibliography

- Le Rider, Jacques. (1982). *L'affaire Otto Weininger*. Paris: Presses Universitaires de France.
- Porge, Erik. (1994). *Vol d'idées?* Paris: Denoël.
- Rodlauer, Hannelore. (1990). *Otto Weiningers Eros und Psyche*. Vienna: Österreichischen Akademie der Wissenschaften.
- Schröter, Michael. (2003). Fliess versus Weininger, Swoboda, and Freud: the plagiarism conflict of 1906 assessed in the light of the documents. *Psychoanalysis and History*, 5, 2, 147–173.
- Swoboda, Hermann. (1904). *Die perioden des menschlichen organismus in ihrer psychologischen und biologischen Bedeutung*. Leipzig: Deuticke.
- . (1906). *Die gemeinnützige Forschung und der eigen-nützige Forscher: Antworten auf die von Wilhelm Fliess erhobenen Beschuldigungen*. Vienna: Braumüller.
- . (1911). *Otto Weiningers Tod*. Vienna: F. Deuticke.
- . (1917). *Das Siebenjahr*. Leipzig: Orion.
- Weininger, Otto. (1906). *Sex and character*. London: W. Heinemann. (Original work published 1903)

---

## SYMBIOSIS/SYMBIOTIC RELATION

In Margaret Mahler's theory of the mother/child relationship, the symbiotic relation is a very early phase of development that follows the phase of normal primary autism and precedes the separation/individualization phase. The symbiotic relation is characterized by an omnipotent sense of the total enmeshing of mother and child, who thus form a "unity of two."

The concept of symbiosis and symbiotic relation came out of Margaret Mahler's observations of the mother-baby relationship, and was later applied to clinical practice. Although a psychological concept, it is also part of the phenomenology of object relations.

Its origins can be found in the description of the "purified ego-pleasure" (1915c) and the "oceanic feeling" of Freud (1930a [1929]), what Margaret Mahler considered as the experience of a baby who has not yet differentiated its identity from that of its object.

The specific features of symbiosis can best be seen against the description of the phase that precedes it as well as those that follow it: as Margaret Mahler points out, symbiosis overlaps the other phases. In the very first phase of life, that of normal primary autism, narcissism is absolutely primary and under the sway of physiological rather than psychological processes. There is a prolongation of the fetal state as Freud described it in 1911; its aim is the homeostatic equilibrium of the organism with the environment (1911b). The shell surrounding this egg forms a protective barrier that is not positively cathected.

With symptoms, the shell begins to crack and—an essential point for Mahler—cathexis passes from the center to the periphery. This marks the beginning of a displacement from the self to the object that is still only obscurely perceived. The object exists in a partial state: that is, it is only apprehended through parts of the body that are experienced as having an object nature. The fully external character of the object is not yet constituted.

From the point of view of energy, while the primary autistic phase is characterized by the existence of an "undifferentiated" energy, differences start to appear in the symbiotic phase between the "good" or "bad" qualities of experience, making of this phase a "quasi-ontogenetic basis for splitting," long before the separation between the ego and the object occurs. This phase starts around the second month of life, and reaches its peak at around four or five months, just at the time when the phase of separation-individuation is filtering into the symbiotic relation. The relation between the inside and the outside of the body emerges progressively from what Margaret Mahler calls a "hallucination" or a "somato-psychic fusion."

Although Margaret Mahler is here describing a state rather than a defense enabling one to reach that state, she thinks that projective mechanisms play a role in maintaining, thanks to a displacement outwards of anything that disrupts or disturbs the symbiotic relation. In her view, failure in the development of the processes of individuation makes the child regress to the stage of symbiotic relation with the mother, thus running the risk of shutting it off in a psychotic disorganization, a "symbiotic psychosis" characterized by a delirious state of undifferentiation between the ego and the object. Leaving the symbiotic phase entails the risk of depression.

Even if Margaret Mahler sees it as closer to secondary narcissism (Freud), the concept of symbiosis can constitute a bridge between primary and secondary narcissism. It corresponds to what René Spitz calls the “pre-objectal stage” (1965), which in his view partly covers that of the symbiotic phase. But René Spitz links these processes to those of primary identification with the mother. Donald Winnicott also comes close to the description of the mother-baby symbiosis with his concept of “primary maternal preoccupation,” in which the state of maternal hypersensitivity leads the primitive mother-baby couple to live in a particular environment, a prolongation of the uterine environment in which communication between mother and child is immediate and not subject to the vagaries of separation. Wilfred Bion (1970), in his work on bonding, takes up the idea of a so-called “symbiotic” relation being set up between the leader of a group and the group in question. In this case, the encounter is beneficial for both parties, as opposed to the indifference of the commensal bond and the destructivity of the parasitic bond.

Margaret Mahler did not sufficiently develop the link with psychoanalytical clinical practice and in consequence, left to one side the active role played by the processes of identification. Unlike Melanie Klein, who considers the role of anxiety right from the start of life, in the act of introjection-projection on the basis of narcissistic and secondary identifications, Mahler wants to separate the early infantile problematic from the necessary perception of separation—whatever form it might take—between the ego and the object. We can say that the idea of a fundamental “transitionality,” as developed by Winnicott, leading from the fetal state to the individuation of the human being, is very influential in Mahler’s thinking on the concept of symbiosis.

In spite of the deep truth that it contains, insofar as it presides over all psychological development, in Margaret Mahler and those who place it at the center of their theorizing, this idea tends to evade the question of the suffering of mourning, which presides over any passage towards individuation, or towards “psychological birth,” as Mahler calls it.

CLÉOPÂTRE ATHANASSIOU-POPESCO

*See also:* Framework of the psychoanalytical treatment; Gender identity; Individual; Individuation (analytical

psychology); Infantile psychosis; Mahler-Schönberger, Margaret; Maternal; Primary identification; Principle of identity preservation; Purified-pleasure-ego; Relations (commensalism, symbiosis, parasitism); Self (true/false); Self-mutilation in children.

### **Bibliography**

- Bion, Wilfred R. (1970). *Attention and interpretation*. London: Tavistock.
- Freud, Sigmund. (1911b). Formulations on the two principles of mental functioning. *SE*, 12: 213–226.
- . (1915c). Instincts and their vicissitudes. *SE*, 14: 109–140.
- . (1930a [1929]). Civilization and its discontents. *SE*, 21: 57–145.
- Mahler, Margaret S.; Pine, Fred; and Bergman, Anni. (1975). *The psychological birth of the human infant*. New York, Basic Books.
- Spitz, René A., and Coblinger, W. G. (1965). *The first year of life. A psychoanalytic study of normal and deviant development of object relations*. New York: International Universities Press.
- Winnicott, Donald W. (1958). *Through paediatrics to psycho-analysis*. London: Tavistock.

### **Further Reading**

- Gergely, György. (2000). Reapproaching Mahler: New perspectives on normal autism, symbiosis, splitting and libidinal object constancy from cognitive developmental theory. *Journal of the American Psychoanalytic Association*, 48, 1197–1228.

---

## **SYMBOL**

From a psychoanalytic perspective, the symbol refers to all indirect and figurative representations of unconscious desire (symptoms, dreams, slips of the tongue, parapraxes, etc.). This conception of the unconscious symbol depends on a relation of general substitution where one thing takes the place of another; but unlike the term’s conventional meaning, defined by the conjunction between the symbol and what is symbolized, the unconscious symbol is defined by a disjunction between symbol and symbolized.

Freud clarified this conception of the symbol following the “Project for a Scientific Psychology” (1950c [1895]), describing it as a mnemonic symbol subsequent

to his research into hysterical symptoms. In the case of a “standard” symbol, the connection between the symbol and what is symbolized remains, as in the example that Freud gives of the knight who fights for his lady’s glove but who knows full well that the glove owes its importance to her. In this synecdoche of part for whole the conjunction of meaning is clear. With hysteria however, it is the loss of the connection between the symbol and what is symbolized that is noteworthy: “The hysteric, who weeps at A, is quite unaware that he is doing so on account of the association A-B, and B itself plays no part at all in his psychological life. The symbol has in this case taken the place of the thing entirely” (1950c, p. 349).

As a result of this disjunction of meaning, the affect that was bound to what is symbolized attaches itself to the symbol. In both instances the substitution assumes a similarity between the symbol and what is symbolized (A/B), and thus emerges the tension at the very heart of symbolic substitution between a nonsensical literal interpretation and a symbolic interpretation that supports a surplus of meaning because of the very denial or negation [*négation*] precluding the pure and simple assimilation of the two terms in question. In the case of the hysterical symbol, it is the impossibility of invoking denial that would explain the symptom’s apparent absurdity.

What might appear here as a simple relation of substitution between two terms—the symbol and what is symbolized—allows, in fact, for an interpretation where meaning might be attributed according to context. The symbol’s abundance derives from its polysemy, but only reference to a regulated system of interpretation can lend precision to the symbol, hence the requirement to define the system and determine what it is that permits this regulation.

Freud hesitated between two rules of interpretation. Either it depends on individual context—specifically, a person’s individual associations, which permit them to discover hidden meaning, as in the hysterical symptom or in dreams—or on collective context—specifically, a work of transindividual culture that clarifies meaning, as in “symbolic dream-interpreting” (1900a, p. 97). On the subject of the dream, he depicted sexual symbols that did not arouse associations for the dreamer but that the analysis would supply by referring to the symbolism of collective compositions (myths, tales, proverbs, songs, etc.); this enabled him to rediscover the correlation between the manifest and latent symbol.

This obscure and concealed comparability appeared to be based on a relationship of equivalence (a tree for the male sex organs, a cave for the female sex organs), but also occasionally on a relationship of proximity (nudity symbolized by clothes and uniforms).

If symbols are multiple, the field of what is symbolized is highly limited, relating ultimately to the domain of sexual instinct. The theory of a predetermined and stereotyped sexual symbolic, in the service of an oneiric representability, corresponds with Freud’s wish to contest Jung’s theory of symbolism, whose conception of the “libido-symbol” ends up denying the importance of the sexual instinct in psychic behavior. Ernest Jones’s key paper, “The Theory of Symbolism” (1916), seeks moreover to reinforce the Freudian theory of “symbolic dream-interpretation”; for Jones all true symbolism is the substitute for repressed drives/instincts: “Only that which is repressed is symbolized and only that which is repressed requires symbolization.”

It is a question then of finding a rule of interpretation that can substantiate the discovery of the unconscious. To back up his theory Freud adopted the linguist Hans Sperber’s theory of a primitive language [*langue*] parallel to the primitive language system [*langage*] of sexuality in which all symbolic connections would appear as traces and relics: “That which today is linked symbolically was in all probability formerly linked conceptually and linguistically.” Freud is thus compelled to set out from a real anteriority, in a proximate association, or identity even, that belongs, through a similar association, to language and to a process of symbolization that is inseparable from the work of instinct.

Thus, the theory of the symbolic designates more of a structural demand than a clinical truth. In clinical terms, Freud always mistrusted instant symbolic interpretations and preferred to rely on individual associations that allowed him to uncover a linguistic usage that would justify the use of a symbolic representation.

Freud’s theory of the symbol cannot therefore be separated from a conception of symbolization, which bears out the fact that the psychoanalytic approach is more a tripartite theory of interpretation, where it is necessary to consider the subject who symbolizes, than a theory of translation seeking to proceed via the simple substitution of one term for another. Freud’s

uncertainty demonstrates the difficulty of constructing a theory of the symbol while making allowances for the symbol both as a motivated sign (the symbol for Ferdinand de Saussure, corresponding to a natural analogy between symbol and symbolized) and as an arbitrary sign (the symbol for Charles Sanders Peirce, corresponding to the standard rule governing the signifier and signified, in other words to the arbitrary linguistic sign).

What is problematic with this theory of the symbolic is the conception of symbolization as a failure of sublimation rather than as its accomplishment. This opposition marks a return in too radical a fashion to the opposition between a symbolism of the unconscious and a symbolism of language. Post-Freudian theorists have sought to reconcile these different aspects of the symbol, whether through a semantic perspective associated with the image, as in the case of Melanie Klein and post-Kleinian theorists, or through a syntactic approach associated with language, as in the case of Jacques Lacan. It is a question in both cases of reviving the Freudian intuition of the symbol as the result of a process of symbolization. To Klein's interpretation of the imaginary, which retains a certain psychological realism, Lacan opposed reference to the symbolic order that represents an intellectualization of the unconscious.

The approach to symbolization as a process presupposes the preservation of that which Freud, rather awkwardly, wished always to have prevail: namely, the necessity for a dualism, for the articulation of a viable distinction between the symbolism of the image and the symbolism of language. The truth of Freudian empiricism in the theory of primitive language, like the original proximity of the symbol, is no doubt to mark the importance of this fundamental proximity of the psyche with the body as the juncture between representation and affect, between meaning and primitive animism, characteristic of the hallucinatory satisfaction of desire.

ALAIN GIBEAULT

*See also:* Anagogical interpretation; Archetype (analytical psychology); "Claims of Psycho-Analysis to Scientific Interest"; Compensation (analytical psychology); Complex (analytical psychology); Dream symbolism; Idea/representation; Infantile psychosis; Negation; *Psychology of the Unconscious, The*; "Project for a Scientific Psychology, A"; Self (analytical psychology); Symptom-

formation; Mnemic symbol; Symbolic, the (Lacan); Symbolism; Thought-thinking apparatus; Visual arts and psychoanalysis.

### **Bibliography**

- Freud, Sigmund. (1900a). The interpretation of dreams. Part I, *SE*, 4: 1–338; Part II, *SE*, 5, 339–625.
- . (1950c [1895]). Project for a scientific psychology. *SE*, 1: 281–387.
- Jones, Ernest. (1916). The theory of symbolism. *Papers on psychoanalysis*. Boston: Beacon.

### **Further Reading**

- Segal, Hanna. (1978). On symbolism. *International Journal of Psychoanalysis*, 59, 315–320.

---

## **SYMBOLIC EQUATION**

The concept of *symbolic equation* appears for the first time in Hanna Segal's first paper, "Some Aspects of the Analysis of a Schizophrenic" (1950), in connection with her schizophrenic patient's difficulty with symbolizing. The patient made no distinction between symbols and the objects they symbolized. For him, being like something and being something were the same. Symbols were equivalent to the things symbolized. There was an unconscious equation between the two. In her second paper, "A Psycho-Analytic Contribution to Aesthetics" (1952), Segal describes symbol formation as a precipitate of mourning.

In "Notes on Symbol Formation" (1957), Segal formulates a theory of the dynamics of symbol formation and the role played by projective identification. Symbolism as a tripartite relation among self, object, and symbol. When projective identification is excessive, part of the ego becomes identified with the object, and the symbol, a creation and function of the ego, becomes identified with the object symbolized. In the depressive position, the object is given up, and a symbolic representation of the object is formed in the ego in the process of mourning. Segal offers the differentiations in Figure 1.

In normal repression, there is communication between the unconscious and the conscious through symbols. In the kind of repression that Freud called excessive, the unconscious is split off from the con-

FIGURE 1

Symbolic Equations	Symbols
<ol style="list-style-type: none"> <li>1. Arise in the paranoid-schizoid position through projective identification.</li> <li>2. The symbol's own characteristics are not recognized. They are treated as though they were the original object.</li> <li>3. The symbolic equation is used to deny the loss of the object.</li> <li>4. It is the basis of acting out and symptoms.</li> </ol>	<ol style="list-style-type: none"> <li>1. Symbols are formed when projective identification is withdrawn in the depressive position, and they are the precipitate of mourning.</li> <li>2. The symbol is not felt to <i>be</i> the object, but <i>represents</i> the object. Its own characteristics are recognized and respected.</li> <li>3. The symbol is used, not to deny, but to overcome the loss.</li> <li>4. Symbolism is at the basis of sublimation and it governs communication both external and internal.</li> </ol>

scious, and in the return of the repressed, consciousness is invaded by concrete symbols, as in hallucinations.

Under stress, there may be a regression from symbolic functioning to symbolic equation. For instance, in the schizophrenic patient described in Segal's first paper, thoughts and words formed in the depressive position became concretized, so that the patient could not, for instance, use names, because he experienced a name as biting into the person named. In "Depression in the Schizophrenic" (1956), Segal cites the example of a girl who wrote a story about Lancashire witches and in a breakdown felt herself persecuted by Lancashire witches.

In her later papers, Segal, following Wilfred Bion, views pathological projective identification, not excessive projective identification, as responsible for disturbances in symbol formation. She made connections between her work on symbol formation and Bion's alpha- and beta-elements.

HANNA SEGAL

*See also:* Neurosis; Infantile psychosis; Schizophrenia; Symbolism; Symbolization, process of.

### Bibliography

- Segal, Hanna. (1950). Some aspects of the analysis of a schizophrenic. *International Journal of Psycho-Analysis*, 31, 268–278.
- . (1952). A psycho-analytic contribution to aesthetics. *International Journal of Psycho-Analysis*, 33, 196–207.
- . (1956). Depression in the schizophrenic. *International Journal of Psycho-Analysis*, 37, 339–343.
- . (1957). Notes on symbol formation. *International Journal of Psycho-Analysis*, 38, 391–397.
- . (1978). On symbolism. *International Journal of Psycho-Analysis*, 59, 303–314.
- . (1991). *Dream, phantasy, and art*. London: Routledge.

## SYMBOLIC REALIZATION

Symbolic realization is a psychoanalytically-inspired technique that is used in psychotherapy with schizophrenic patients.

In 1947, in a supplement to the *Revue Suisse de psychologie et de psychologie appliquée*, Marguerite A. Sechehaye (1887–1964), a psychoanalyst in Geneva, described the technique in the article: "La réalisation symbolique: Nouvelle méthode de psychothérapie appliquée à un cas de schizophrénie (Symbolic realization: A new method of psychotherapy applied to a case of schizophrenia). In 1950 the patient's own account of her illness and treatment was published, as she described them to her therapist. It was accompanied by a psychoanalytic interpretation of how the therapy developed (Sechehaye, *Journal d'une schizophrène* [Autobiography of a Schizophrenic Girl]).

Symbolic realization is a psychotherapeutic technique that combines the active support of the psychotherapist for the psychotic patient (this implies adjusting the frame) with interpretations of the patient's unconscious fantasies in terms of libidinal development. This approach is based on the importance Sechehaye accords to real frustration in the disintegration of the ego, which lies at the root of schizophrenic psychosis. It follows from this perspective that the role of the therapist is to seek to satisfy the fundamental needs of the patient and repair the initial frustrations not only by interpreting the patient's fantasies but also by establishing a real, even a physical, contact with the patient. This attitude is considered to help the patient to regress in order to be able to progress, resume the interrupted course of infantile development, and thus recover the sense of reality.

This notion, which is akin to that of therapeutic regression (Donald W. Winnicott, Michael Balint), represents a pioneering and original approach to psychotic disorders. However, the active intervention of



the therapist in the patient's life in order to satisfy her needs constituted an acting out that was not interpreted as such in a transference the importance of which was underestimated.

JEAN-MICHEL QUINODOZ

See also: Sechehaye-Burdet, Marguerite; Switzerland (French-speaking).

### **Bibliography**

Laplanche, Jean, and Pontalis, Jean-Bertrand. (1967). *Vocabulaire de la psychanalyse*. Paris: Presses Universitaires de France.

Sechehaye, Marguerite A. (1951). *Autobiography of a schizophrenic girl; with analytic interpretation by Marguerite Sechehaye (Grace Rubin-Rabson, Trans.)*. New York: Grune and Stratton.

———. (1954). *Introduction à la psychothérapie des schizophrènes*. Paris: Presses Universitaires de France.

———. (1957). La réalisation symbolique, un catalyseur de la structuration du moi schizophrène. In *Acta psychotherapeutica, psychosomatica et orthopedagogica*. Basel.

———. (1970). *Symbolic realization; a new method of psychotherapy applied to a case of schizophrenia (Barbrö Würsten and Helmut Würsten, Trans.)*. New York: International Universities Press. (Original work published 1947)

---

## **SYMBOLIC, THE (LACAN)**

For Jacques Lacan, *the symbolic*, or the *symbolic order*, is a universal structure encompassing the entire field of human action and existence. It involves the function of speech and language, and more precisely that of the signifier. It appears as an essentially unconscious, latent apparatus.

The idea of the symbolic is contemporaneous with the birth of psychoanalysis since the traces linked to repressed infantile sexual experiences are symbolically reactualized in adulthood as defensive symptoms. The fact that Freud emphasized memory and reminiscence in his earliest theoretical work is enough to indicate the primacy of symbolic traces in psychopathology. The Oedipus complex, the avatars of the primal relationship with the mother, and the function of the dead father all take on their importance because they function on the same axis where the signifier emerges as

the mainspring of the symbolic. As Lacan wrote in the "Function and Field" essay, "Freud's discovery was that of the field of effects, in man's nature, of his relations to the symbolic order" (2002, p. 63). Further, Lacan's entire body of work testifies to the fact that he was trying to restore the symbolic to its full status in psychoanalysis.

The impact of the symbolic is felt on several levels: first in limits placed on social alliances and relationships by a certain number of mechanisms, for which the traditional model is the pact. At another level, the symbolic intervenes in the form of discrete elements, namely signifiers, that are overdetermined as the prevalent forms of the imaginary, affective relations, and the choice of sexual objects.

Lacan repeatedly referred to the canonical example of the "child with the reel" from *Beyond the Pleasure Principle* (Freud, 1920g) in order to emphasize that the mark of the absence of the beloved object is realized by the fort-da game of phonetic opposition that represented the appearance and disappearance of the mother. This correlation between the missing object and a symbolic signifying mark inscribed in language removes the object's concrete features and grants it a level of conceptual force.

The emergence of the signifier in the symbolic is best shown by the infant's initiation into the dialectical field of demand and desire, for it is in the experience of vital distress and the appeal to a caretaker that a split occurs. Even if this caretaker satisfies a vital need, there is still a gaping lack of being. This equivocal division is brought about by the signifier of the first demand. It brings with it consequences beyond the frontiers of infancy and perpetuates a radical division in subjectivity. It also grants to the unconscious Other its symbolic place because the ultimate meaning of this signifier is assumed by the subject to reside in this other scene.

In the demand, the inexpressible, originally repressed part of the signifier becomes the cause of desire by the process of repetition. Later, the Oedipus complex normalizes the structure by assigning a definitive meaning to a lack previously put in place—namely that the mother, as primordial Other, is assumed to possess the phallus, and the father, by prohibiting incest, reinforces the fact that the phallus is absent by conferring on it a symbolic function. Thus the father's prohibition makes the phallic signifier cause desire in the very place where repression had left

a hole. From that point on, this operation links the lack (symbolic castration) to the law of language, in order to make it reappear as symbolic debt. The symbolic order is thus constituted as an autonomous system of signifiers, a system that is governed from the Other and to which the subject is subjugated. The primary character of the symbolic led Lacan to conceive of it as one of the dimensions constituting the Borromean knot, a formalized structural schema that also includes the imaginary and the real.

JEAN-PAUL HILTENBRAND

*See also:* Blank/nondebilitating psychosis; Castration of the subject; Child analysis; Death instinct (Thanatos); Demand; Ethics; Fantasy, formula of; Female sexuality; Feminism and psychoanalysis; Foreclosure; Fort-Da; Ego ideal/ideal ego; Imaginary identification/symbolic identification; Imaginary, the; Imago; Knot; L and R schemas; Matheme; Mirror stage; Name-of-the-Father; Neurosis; Object; Object *a*; Optical schema; Phallus; Privation; Psychoses, chronic and delusional; Real, the; Real, Imaginary, and Symbolic father; Sexuation, formulas of; Signifier; Structuralism and psychoanalysis; Subject; Subject's desire; Symbol; Symbolization, process of; Symptom/sinthome; *Thalassa: A Theory of Genitality*; Topology; Unary trait; Want of being/lack of being.

### **Bibliography**

Freud, Sigmund. (1920g). Beyond the pleasure principle. *SE*, 18: 1–64.

Lacan, Jacques. (2002). The function and field of speech and language in psychoanalysis. In his *Écrits: A selection* (Bruce Fink, Trans.). New York: W. W. Norton (Original work published 1953)

---

## **SYMBOLISM**

The evolution of representational capacities and symbolic expression has contributed essentially to human thought, language, and culture. There are different symbolic processes, and the symbolism particularly described and interpreted in psychoanalysis differs, in many respects, from what is designated by the same term in other disciplines. While psychoanalysis is interested in language and other forms of symbolism, psychoanalytic or unconscious symbols were early recognized as universal and ubiquitous expressions of the dynamic unconscious mind. In ordinary linguistic usage, a flag may represent a country, and a cross may

represent a Christian religious reference. In the case of the flag and the cross and other emblems or pictorial metaphors, the relationship between the signifier and its referent is both within conscious awareness and in accord with social and cultural convention. In contrast to psychoanalytic symbols, these symbols are consciously understood by the individuals within a society in which they are used. They are not disguised, and they serve conscious communication.

In contrast, psychoanalytic symbols are usually disguised by and from the individual who uses them and may not serve any conscious or intended internal or external communication. The meanings of psychoanalysis symbols are relatively independent of social, cultural, and historical settings and are neither taught nor learned. Psychoanalytic symbolism is not a product of education and evolves spontaneously in human development. Given the fact that these symbols are universal in individuals as well as cross-cultural, the capacity for such symbols is innate, though their development depends upon human development and experience.

Psychoanalytic symbols emerge as a result of the interaction of the instinctual drives, defenses, and other ego functions with the developmental experience of the infant and child. Although psychoanalytic symbols may take on additional meanings in later phases of development and may become linked to metaphor, they are essentially products of archaic, infantile processes. These symbols emerge in conjunction with the development of the body ego and object relations, so that there are symbols of both body parts and of the parents and siblings. Spontaneous in origin and typically sensorial, the symbols create a concrete bridge between the body and the primary object world. In a “symbolic equation” (Segal, 1978), the person cannot distinguish between the symbol and the thing symbolized. The symbolic equation denies separateness between self and object, whereas symbolic representation bridges prior loss.

Psychoanalytic symbols are typically linked to external, perceptual reality, manifest in the closeness of the symbol perceptually toward what is signified. Thus, sticks, swords, and wands resemble the phallus; tunnels, caves, houses, boxes have a perceptual similarity to the female genitalia. The body image and body surface are the locus of initial, symbolic representation of self and object, which are then extended or projected to other surfaces. Symbols thus arise in the potential to other surfaces. Symbols thus arise in the potential space between the “I” and the “non-I,” more

closely related to the primary process rather than to verbal language and rational thought.

As Freud (1900a) noted, psychoanalytic symbolism is ubiquitous in myths, legends, art, literature, slang, jokes, obscenities, etc. Psychoanalytic symbols unconsciously represent, in addition to aspects of the self and childhood objects, coitus, pregnancy, birth, rebirth, castration, and death. Symbolism is utilized in symptom-formation, for example, a paralyzed limb representing impotence or castration. The name *Oedipus* or “swollen foot,” unconsciously represents erection and mutilation-castration.

Ernest Jones (1916) summarized that only what is repressed is symbolized and needs symbolic expression as a psychoanalytic or unconscious symbol. The symbol condenses unconscious wish and defense, a compromise formation permitting disguised “symbolic gratification.” The most frequent symbols are probably those of the male and female genitals, and these symbols more commonly appear in regressive states such as daydreams and dreams. Psychoanalytic symbols, however, may be found in association with all developmental phases. There are symbols referring to the breast as well as to the mouth, tongue, and teeth; similarly, feces may represent money, gifts, and denigrated aspects of the self or object. Psychoanalytic symbols are often overdetermined as in the bisexual and biparental symbolism of animals, exemplified in the many meanings of rats for the “Rat Man” (Freud, 1909d). The rat was interpreted to mean penis, feces, money (rates), baby, as well as despised greed, rate, etc.

Psychoanalytic symbols may have multiple stratified meanings and, in contemporary analysis, there is appreciation of overdetermination and possible change of function. For example, the “pit and the pendulum” may symbolically represent the vagina and the penis but also castration and the threat of castration. In oral terms, the pit may represent the mouth, and the pendulum the tongue.

That symbols may acquire cultural and religious significance and take on other metaphorical meanings does not alter the original and primary meaning of the symbol (Blum, 1978). A cave may represent a grave without losing its earlier meaning of a womb or female genital, with the earth having acquired the meaning of mother.

Clinically, symbols are not pursued as an end in itself and are not the primary locus of psychoanalytic

interpretation. There are no rigid formulas for symbolic decoding or interpretation, and patients may not directly associate to symbolic expressions. Symbols are interpreted in the context of the psychoanalytic process.

Comparable to an ancient language, symbolism may be adaptively appropriated in linguistic communication inside and outside psychoanalysis (Blum, 1995).

HAROLD P. BLUM

*See also:* Cinema criticism; “Dreams and myths”; *Disque vert, Le*; Functional phenomenon; *Group Psychology and the Analysis of the Ego*; Obsessional neurosis; *Psychoanalysis of Children, The*; *Psychoanalyse des nevroses et des psychoses*; Symbol.

### Bibliography

- Blum, Harold P. (1978). Symbolic process and symbol formation. *International Journal of Psycho-Analysis*, 59, 455–471.
- . (1995). Symbolism. In B. Moore and B. Fine (Eds.), *Psychoanalysis. The Major Concepts*. (pp. 149–154). New Haven, CT: Yale University Press.
- Freud, Sigmund. (1900a). The interpretation of dreams. *SE*, 4–5.
- Jones, Ernest. (1916). The theory of symbolism. In *Papers on Psychoanalysis*. Boston: Beacon Press.
- Segal, Hanna. (1978). On symbolism. *International Journal of Psycho-Analysis*, 59, 303–314.

---

## SYMBOLIZATION, PROCESS OF

The term *symbolization* is hardly discussed by Freud, although the process is fundamental to mental activity. We can define symbolization as the operation by which something comes to represent something else for someone. While it may appear as the substitution of one object for another, it is primarily the result of a process that assumes both the ability to represent an absent object and a subject capable of knowing that the symbol is not the symbolized object.

In this sense it promotes the ability to fantasize and the organization of mental space. From this point of view it is primarily a mechanism enabling the subject to fight against the depression associated with object loss and to limit the flow of affects.

Aside from allowing one term to substitute for another, symbolization designates back and forth flow of meaning between subject and object, between mental reality and external reality, between past and present. This is the effect of the symbolization process, which makes possible a system of intra- and intersubjective exchanges. This can be verified in analytic therapy, which, in the standard model, assumes a relation between two centers of meaning, the analyst and the patient, whose work is possible only on condition that it is referred to an outside agency, which is the “frame” of analysis. The analytic situation thereby appears as both symbolic and symbolizing, in that its mode of operation is based on a structure with three points of reference.

The experience of satisfaction—that of the infant at the breast, as described by Freud in terms of images and memory traces—is a prototypical model that delimits the scope of the symbolization process in the transition from need to drive. Freud defined the drive as a borderline concept between the psychic and the somatic, formed by reworking the hallucination of satisfaction at the breast, and whose constant thrust (as distinct from the momentary or periodic nature of the satisfaction of organic need) relates to the permanence of the object during perception of the total object.

It is, as we know, a postulate also found in the experience of the dream and unverifiable by experience, according to which hallucination is a form of satisfaction. Into this Freud introduced a temporal dimension by distinguishing the period during which the sexual drives are attached to functions of self-preservation (corresponding to the hallucination of satisfaction and the increase in automatic traumatic anxiety) from the period of object-formation, and hallucination of the object, when the mother is perceived as a total object. The structure so described occurs in two stages, which the *análisis* or propping of the drive on organic self-preservation enables us to comprehend as a retroactive reorganization. The symbolization process thus emerges during the split between the framework of need (ingesting milk) and the framework of the drive (incorporating the breast). It is this difference that Jean Laplanche (1980) described in great detail, noting that the displacement from need to drive was simultaneously metonymic with respect to the object (from milk to breast) and metaphorical with respect to the aim (from ingesting to incorporating).

Between narcissistic cathexis (I am the breast) and object cathexis (I have it, that is, I am not it) the dimensions of a psychic space—a topological space—and time are organized. Psychic time evolves through acceptance of a delay, a waiting period, the succession from the time of being to, as Freud himself said, only after the fact, the time of having. Beneath these abstractions, at a more concrete level, we find analyses of symbolic assimilation (Melanie Klein), symbolic equation (Hanna Segal), and pathological projective identification.

From this viewpoint the hallucinatory experience of satisfaction designates the dialectic between the non-optative (I am) and the optative (I want, I am not), which is articulated only on condition that enough time is allocated to the non-optative dimension. This is probably one of the major contributions of Donald Winnicott (1951), namely, to have insisted on the importance of duration during this period of non-optative illusion so that the optative period, the period of disillusion, might become possible.

Thus the experience of object loss results in different outcomes for symbolization given the possibility of forming a dialectic between the time of being and the time of having. This essential difference and the dialectic it involves can be terminated by the illusory wish to unite, at the “same time,” subject and object, memory and perception, in the effort to exclude the object as well as the effort intended to include it.

In this way different modalities of symbolization are designated. The symbolic assimilation controlled by the search for sameness seeks to implicate projection, leaving nothing but the search for immediate satisfaction through action and degrading the symbol, which represents the object, to the status of a signal. Symbolic assimilation can, on the contrary, seek to include the object in the act of projection, which, although it dehumanizes the world by transforming it into abstract entities, nevertheless maintains a link to a universe of indexical signs, where the categories of certainty, foreseeability, and univocity prevail. There are, therefore, two different economies which, depending on the use of the object, can lead in one case to a repression of affects and a splitting of the body through the exclusion of all symbolization (this is the register of non-delusional psychoses and psychosomatic disorganization); and in the other to the preservation of those affects in the psyche through symbolic efflorescence, which, although it seeks to eliminate

difference and distance, nonetheless indicates an attempt at a solution through representation (as shown by delusional psychoses). As Wilfred Bion noted (1970), we cannot say that the psychotic patient is incapable of symbol formation, but that he symbolizes excessively and prevents himself from learning through knowledge of the world.

From this point of view the interiorization of psychic bisexuality becomes the source of unfettered symbolization and creativity. The essential point is to be able to confront maternal invisibility and the terror of the unlimited or the infinite. This assumes the organization of the dialectic of conservation and loss inherent in anal eroticism, which contributes to the differentiation of the inside and outside of the body and ensures that the control of mental activity and sphincter control are cathected in the same way.

The fort-da game (Freud, 1920g) is often considered to be the key experience revealing the formation of symbolization. However, this activity of symbolic substitution through gestures and speech that bear witness to the development of object loss, assumes the manipulation of a simultaneously preserved and expelled internal object, which defines anal eroticism. The experience of mastery demonstrates that the anxiety of destruction by the object associated with orality (to consume or be consumed) is here contained within limits through a third possibility, the external object.

The fault lines in this mediatory function of the third object determine the recourse to variant techniques (face-to-face psychotherapy, psychoanalytic psychodrama) compared to the usual therapeutic situation on the couch. From this viewpoint the analytic framework can be considered a genuine “intermediate region of experience,” to use Winnicott’s phrase, the crucible or matrix of all symbolization, which triggers the operation of the intermediary intrapsychic region known as the preconscious. The movement is of course asymptotic.

Accordingly, the semantic function of the symbol as content is inseparable from its mediatory function, intra- and intersubjective, providing we realize it is less a universal and univocal function (the archetype for Carl G. Jung or the symbolic order for Jacques Lacan) than a personal and polysemic one, making possible processes of sublimation and creation. Rather than being enclosed in a private dimension, true symbolization reveals, on the contrary, as Bion (1970) suggested,

its essentially social dimension. This assumes symbolization is capable of being instructed by the body and the world so it is able to produce other figures, while leaving room for the indeterminate, the uncertain, and the unexpected.

ALAIN GIBEALT

*See also:* Act, action; Alcoholism; Asthma; Cécilie M., case of; Dream symbolism; Disavowal; Displacement; Ethology and psychoanalysis; Hysteria; Object; Representation; Somatic compliance; Suffering; Symbol; Symptom formation; Working through.

### **Bibliography**

- Bion, Wilfred R. (1970). *Attention and interpretation*. London: Tavistock Publications.
- Freud, Sigmund. (1920g). Beyond the pleasure principle. *SE*, 18: 1–64.
- Laplanche, Jean. (1980). *Problématiques III, la sublimation*. Paris: Presses Universitaires de France.

### **Further Reading**

- Blum, Harold P. (1978). Symbolic processes and symbol formation. *International Journal of Psychoanalysis*, 59, 455–472.
- Bucci, Wilma. (1997). Symptoms and symbols: A multiple code theory of somatization. *Psychoanalytic Inquiry*, 17, 151–172.
- Coen, Stanley. (2000). Affect, somatisation and symbolisation. *International Journal of Psychoanalysis*, 81, 159–161.
- Kubie, Lawrence S. (1978). Distortion of the symbolic process in neurosis and psychosis. *Psychological Issues*, 44, 87–114.
- Slade, Arietta. (1999). Representation, symbolization, affect regulation, mother and child. *Psychoanalytic Inquiry*, 19, 797–830.

---

## **SYMPTOM**

Freud created psychoanalysis by giving meaning to symptoms. In his writings following *Studies on Hysteria* (1895d), he continued to investigate the symptom. At that time, psychiatry reduced the symptom to an opaque and incongruous phenomenon of psychic life. Freud focused on the salient and unusual features of the symptom to understand the dynamics of the unconscious and the development of conflicts.

The symptom cannot be considered equivalent to a defense, since the mechanism of defense is more general and its role less obvious. Moreover, defenses function effectively when repression is successful, when projection is obvious, and when the effects of projection are natural. Similarly, insofar as neurotic behavior and parapraxes prove useful to the subject, their unconscious causes are not apparent and are ignored.

The symptom is also distinct from anxiety. Anxiety is far noisier than the symptom, though it is also closely related. Anxiety sounds the alarm that leads from a sense of urgency to the symptom. In fact, the symptom appears to be extinguishing the fires of anxiety, but it does not possess the means to accomplish this. More precisely, the symptom puts an end to anxiety by organizing a new situation different from the one that triggered the anxiety. Thus the symptom corrects the inadequate internal discharge of anxiety by offering the psyche other possibilities for linking and representation. The new situation defines the nature of the symptom and indicates its scope. In the end, it is the drive that constitutes the symptom, and this is why Freud distinguished between symptom and inhibition (1926d [1925]).

When repression fails, the drive can break through, but repression has sufficient power to divert it. Thus, the symptom is formed as a compromise. At one level, the compromise concerns the censorship between the unconscious or preconscious and consciousness. At another level, there is a conflict between the different agencies, with the superego taking the organizing role. Later Freud argued that the conflict between the ego and the id defines neurosis, while that between the ego and reality characterizes psychosis (1924b [1923]).

Thus the course that the symptom takes always depends on the unconscious. Eventually, the play of affect and representation get the better of repression. This happens with the conversion hysteric, who suffers from quasi innervation because she marks her own body with an affect that has regressed to its original state as action. Thereafter, every fantasy is converted into a symptom that is incapacitating, but comfortable. Soon this same process is projected by a phobia and frozen in a representation, which leaves a gap in affect that is filled by anxiety (Freud, 1915d, 1915e). Because of the ambivalence of desire and defense, the symptom that the ego has established in a state of “extraterritoriality” (1926d [1925], p. 97) gains ground bit by bit, just like a foreign army, by extending its surveillance beyond the phobic object to any fantas-

matic object that can resonate with it. The defensive rituals of the obsessional become similarly eroticized by invading thought.

Finally, beyond the borders of the ego, the symptom may bring a relative gain, and the individual and other people may derive from it what Freud called a “secondary gain” (1926d [1925], pp. 99–100). For instance, the symptom may establish an internal equilibrium in the structural field from which it arises or that it organizes. Such is the diversity of pathology that it may also perform a preventive or reparative function outside of itself, as when an obsession precedes or follows a depressive episode or a hallucination makes real what mental life can no longer accept.

AUGUSTIN JEANNEAU

*See also:* Amnesia; Anorexia nervosa; Autosuggestion; Bulimia; Cathartic method; Change; Claustrophobia; Cure; Dipsomania; “Dostoyevsky and Parricide”; Doubt; Encopresis; Enuresis (bedwetting); *Five Lectures on Psycho-Analysis*; Flight into illness; Forgetting; Hypochondria; Hysteria; Hysterical paralysis; Indications and contraindications for psychoanalysis for an adult; Infantile neurosis; Inhibition; *Inhibitions, Symptoms, and Anxiety*; Interpretation; *Introductory Lectures on Psycho-Analysis*; Mythomania; Narcissistic neurosis; Obsession; Omnipotence of thought; Pain; Persecution; Psychic reality; Psychoanalytical nosography; Psychoanalytic semiology; Psychotherapy; Reaction-formation; Resolution of the transference; Schizophrenia; Self-mutilation in children; Slips of the tongue; Stammering; *Studies on Hysteria*; Substitutive formation; Symbol; Symbolic equation; Symptom-formation; Tics; Ulcerative colitis; War neurosis.

### **Bibliography**

- Freud, Sigmund. (1915d). Repression. *SE*, 14: 141–158.
- . (1915e). The unconscious. *SE*, 14: 159–204.
- . (1924b [1923]). Neurosis and psychosis. *SE*, 19: 147–153.
- . (1926d [1925]). Inhibitions, symptoms, and anxiety. *SE*, 20: 75–172.
- Freud, Sigmund, and Breuer, Josef. (1895d). *Studies on hysteria*. *SE*, 2.

### **Further Reading**

- Luborsky, Lester. (1996). *The symptom-context method: Symptoms as opportunities in psychotherapy*. Washington DC: American Psychological Association.

## SYMPTOM-FORMATION

Symptom-formation is the process leading to the production of a symptom—the production, that is to say, of a “sign” or “indication” of a functional disturbance.

The word *symptom* was borrowed by psychoanalysis from medical language. Even its etymology (Greek, “that which is held together”) suggests a link between the symptom and what it indicates (and it is worth noting, too, that *syndrome*, a set of symptoms, is likewise derived from Greek elements, meaning, in this case, “that which proceeds together”). That having been said, it is important to bear in mind that there is a broad difference between a sign (implying an intentional designation) and a mere indication (implying merely coincidence, without intentionality).

As early as his first psychoanalytical writings, Freud plumbed for the former sense, arguing that to produce a symptom was to produce a sign, that a symptom always had a meaning, even if that meaning were lost on the patient himself. *Studies on Hysteria* (1895d), or at any rate Freud’s contribution to it, is largely dedicated to the illustration of this thesis: “I have examples at my disposal,” he wrote, “which seem to prove the genesis of hysterical symptoms through symbolization alone” (p. 179).

Indeed, for Freud, the symptom, like the dream, was a compromise-formation via which a wish struggled to achieve fulfillment, albeit merely a partial one: “A symptom arises,” he wrote to Wilhelm Fliess on February 19, 1899, “where the repressed and the repressing thought can come together in the wish-fulfillment” (*SE*, 1, p. 278). Like dream-images, the symptom was overdetermined, and its formation relied on the processes of condensation and displacement. Unlike the dream-work, however, which led to the creation of images, symptom-formation resulted in the kind of bodily expression of which hysterical conversion was the paradigm; in the emergence of obsessive ideas as in obsessional neurosis (in which case secondary symptoms might arise also as defenses against the primary ones); in phobic avoidances; and so on.

More generally, the work of symptom-formation gave rise to mental processes and types of behavior that were repetitive and relatively “isolated”—that were not, in other words, integrated into other aspects of the patient’s personality. The patient would usually recognize these as pathological in nature, and seek

treatment, a fact which distinguished such symptoms from fixed “character traits.”

The fact is that Freud’s entire work, in its attempt to elucidate the neuroses, continually strove for a better understanding of the processes of symptom-formation. Thus in a letter to Jung dated June 15, 1911, distancing himself from his first theory of the trauma, he made the following essential correction: “symptoms spring not directly from the memories but from the fantasies built on them” (1970a, p. 260). He would later review the whole problem once more in the light of his second topography (structural theory) and his second theory of the instincts, in *Inhibitions, Symptoms and Anxiety* (1926d).

To summarize, Freud’s theory viewed the formation of symptoms from the standpoint of “semiology” in both the medical and the linguistic senses of the term (a fact pointed up notably by Jacques Lacan, whose position is famously encapsulated in the claim that “the unconscious is structured like a language”). This view did not hold good, however, beyond the sphere of neurosis proper: in the “actual neuroses,” the manifest symptoms had no psychic meaning (Freud, 1916–17a). Absent the mentalization of fantasies, libidinal energy flowed directly into somatic processes—a mechanism that has been studied in more recent times by the Paris school of psychosomatic medicine (Marty, 1976, 1980).

Inasmuch as the symptom expressed a compromise between instinctual satisfaction and defense, its motor was a dynamic that in all cases sought to reestablish an equilibrium, but that also determined the form of individual symptoms as well as the place each would occupy within a specific clinical entity.

It was unpleasure, first and foremost, that triggered the mechanism of symptom-formation—an unpleasure that derived from pleasure and that could not be accounted for save in terms of the confrontation between the internal pressure exerted by fantasy and the idea of the external danger that depended directly upon it. Hitherto, this calculus of pleasure has been the responsibility of repression, along with the other defenses that either collaborated with repression or ensured mastery over the instincts by their own efforts. The formation of a symptom was invariably necessitated by a strengthening of the instinct, whether this increased pressure was attributable to biology, to fantasy, to reality, or to external events. The failure of defense in all cases resulted in the first instance in the

emergence of anxiety. Whereas in the actual neuroses anxiety was nothing more than an almost reflexive return to the pathways of discharge of the first great traumas, the situation here made it into a signal of danger and a call for the symptom to arise.

The interplay between affects and ideas—the components of the instinct, whose reciprocal links and independence from each other constituted the dynamic of mental life—was thus the crucible of the symptom (Freud, 1894a). Repression functioned by dissociating the two, working on the idea in order to contain the affect and the action that the affect prefigured. The symptom, for its part, was effective because it operated in the interstice, restoring the rights of the instincts by creating new links, more acceptable to the ego, between affect and idea. The simplest instance of this in the context of neurotic repression was doubtless displacement, which was a function of the instinctual shift with respect to the symbol and the resulting decline in the symbol's significance, but other more complex defensive ploys were the locus of the same dynamic: thus the "Wolf Man" used displacement to transform his homosexual desire into a phobic fear of wolves (1918b [1914]), while Schreber was well able to handle fantasy by means of a similarly discrete action of the component instincts, but one which relied not on repression or displacement, but rather on the projection of the idea and the turning of the affect into its opposite, so producing the symptom of feelings of persecution (1911c).

This amounted to an introduction of differences with respect to the formation and the form of the symptom. Both clearly depended on the nature of the conflict: the threat of castration, the loss of the object, narcissism at risk, or alienation; neurosis, depression, borderline state, or psychosis. It has rightly been pointed out that in this account no symptom can exist independently of a corresponding clinical entity.

Two caveats apply in this connection. The first concerns the specificity of defensive modes to given pathological structures, so that each mode is perforce related to a corresponding symptomatic form of decompensation: whether object-dependency is defended against external reality by disavowal, idealization, projection, or some other means, will serve to explain why breakdown occurs in a particular subject, delusion in another, and so on. Within a single neurosis, to take the case of the obsessional, the oedipal situation is the starting-point of a regression to the

anal level of fixation which will determine the compulsiveness and mental retentiveness characterizing the symptoms (Freud, 1926d). Apropos of phobia, however, Freud describes three different phases of symptom-formation: preconscious decathexis, anticathexis of the substitutive idea, and an expansion of this idea's associations and of the vigilance it demands (1915e, pp. 181ff).

The second difficulty is related to the strength of the symptom with respect to the point reached in a particular clinical development. Thus in schizophrenics phobia may rapidly be overwhelmed by the haziness of the dividing-line between inside and outside, so that all projection becomes ineffective. Projection is scarcely more functional in agoraphobics, whose narcissistic inadequacy precludes the establishment of any external protective focus. Cancerphobics, on the other hand, being mentally more obsessional and more objective in their verification procedures, can keep the conflict out of the clutches of depression for some time before it eventually succeeds in bringing the struggle back within the ego. It should be noted, though, that while the neurotic conflict between the ego and the id confines phobia, in its exclusiveness, to a single line of defense, it nevertheless confers on the symptom, not efficacy, for that remains limited, but durability and solidity.

AUGUSTIN JEANNEAU AND ROGER PERRON

*See also:* Actual neurosis/neurosis of defense; Allergy; "Analysis of a Phobia in a Five-year-Old Boy"; Choice of neurosis; Compromise-formation; Conflict; Constitution; Conversion; Daydream; Defense; Displacement; Ego; Eros; Event; Fantasy; Fixation; Hypnoid states; Identification; Identification fantasies; Instinctual impulse; Need for punishment; Overdetermination; Paranoid position; Phobias in children; Principle of constancy; Psychosomatic; Regression; Repression; "Repression"; Reversal into the opposite; Self-punishment; Somatic compliance; Splitting of the ego; Symptom; Unpleasure; Wish fulfillment.

### **Bibliography**

- Freud, Sigmund. (1894a). The neuro-psychoses of defense. *SE*, 3: 41–61.
- . (1911c). Psycho-analytic notes on an autobiographical account of a case of paranoia (dementia paranoides). *SE*, 12: 1–82.
- . (1915e). The unconscious. *SE*, 14: 159–204.



———. (1916–17a). Introductory lectures on psychoanalysis. *SE*, 15–16.

———. (1918b [1914]). From the history of an infantile neurosis. *SE*, 17: 1–122.

———. (1926d). Inhibitions, symptoms and anxiety. *SE*, 20: 75–172.

Freud, Sigmund, and Josef Breuer. (1895d). Studies on hysteria. *SE*, 2: 48–106.

Freud, Sigmund, and C. G. Jung. (1970a). *The Freud/Jung letters: The correspondence between Sigmund Freud and C. G. Jung (Ralph Manheim and R. F. C. Hull, Trans.)*. Princeton, NJ: Princeton University Press.

Marty, Pierre. (1976). *Les mouvements individuels de vie et de mort I: Essai d'économie psychosomatique*. Paris: Payot.

———. (1980). *Les mouvements individuels de vie et de mort II: L'ordre psychosomatique*. Paris: Payot.

### Further Reading

Arlow, Jacob A. (1964). Symptom formation and character formation. *International Journal of Psychoanalysis*, 45, 167–170.

Loewenstein, Rudolph M. (1964). Symptom formation and character formation. *International Journal of Psychoanalysis*, 45, 155–157.

## SYMPTOM/SINTHOME

Lacan defined the *symptom* in several ways: as a metaphor, as “that which comes from the real,” as “that which doesn’t work,” and at the end of his teaching, as a structural fact, whose necessity must be questioned. In 1953 (2002a) Lacan emphasized that the analytic symptom—a neurotic, perverse, or even psychotic symptom; a dream; a slip; and so on—was sustained by a linguistic structure, by signifiers, and by the letters that serve as their material element.

In contrast to medical symptoms, the meaning of which is determined in relation to a referent, the neurotic symptom is blocked speech wanting to be heard and deciphered. Lacan saw the mechanism of metaphor at work in the symptom: when a trauma-inducing signifier is substituted for an element of the current signifying chain, it fixes the symptom and produces its meaning (2002b, p. 158). But interpreting its meaning is not enough. Interpretation works only by focusing on the articulation of the signifiers connected to the symptom; signifiers in themselves are meaningless (1995, p. 270).

**FIGURE 1**

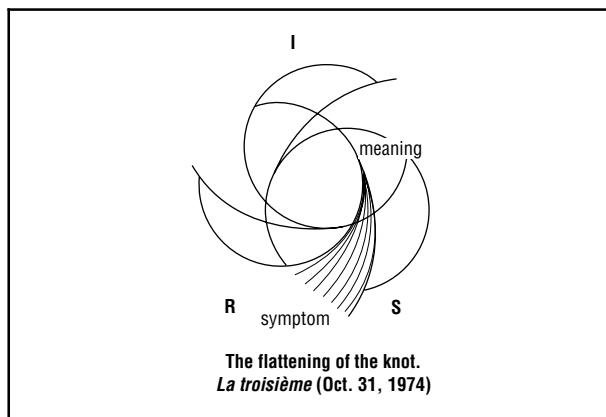

Still, these signifiers must be addressed to an analyst. Because the symptom is a self-sufficient source of jouissance (enjoyment), the subject must be made to feel that behind the symptom is unknown knowledge and a related cause, and that the analyst has become the one who maintains it. The analyst has the responsibility for half of the symptom, Lacan said. He added that analytic training shows how the symptom completes itself.

Starting in 1974 with the Borromean knot with three rings, Lacan envisioned the relationship of the symptom with the real (R), the symbolic (S), and the imaginary (I). The symptom became “that which comes from the real” (1975, p. 185). It is marginally imaginary, while it unfolds in the symbolic (Figure 1).

The symptom, what is going wrong, uses speech to search for meaning. If we respond to it in this register, we can cause it to develop in the imaginary. Equivocal symbolic intervention can undo the certainties of the symptom and cause it to recede.

Lacan makes the function of the symptom specific by starting with a knot with four rings. Freud showed that the formation of symptoms is determined by psychic reality, which is organized by the Oedipus complex. Lacan called this reality “religious,” because it is founded on the belief that the father castrates, even though the laws of language require a renunciation of reality and an assumption of the phallus. Thus the symptom seems to maintain a link with the father, which sustains identification and sexual jouissance. In this knot, the symptom ring knots the real, the symbolic, and the imaginary together (Figure 2).

An unresolved case is that of a subject unsustained by his symptom. This case is represented by a Borromean knot with three rings (Figure 3).

FIGURE 2

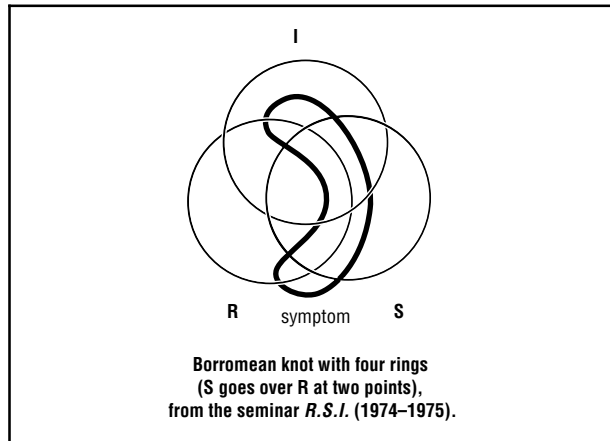
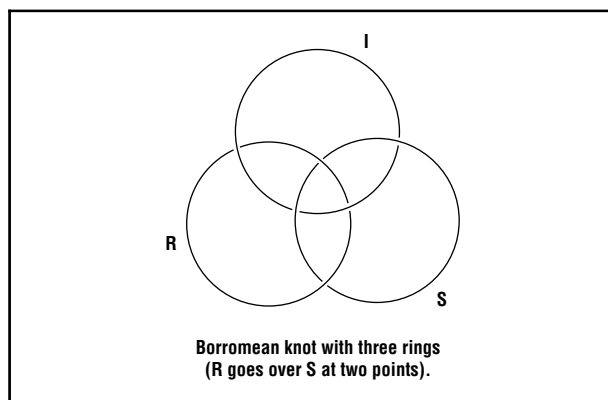

FIGURE 3



Lacan also asked what would happen if there were an error in the knotting of the three rings. Such an error would be fixed in a non-Borromean fashion by a fourth ring, that of the *sinthome*. In his study of James Joyce (2001), he used Joyce as his example of such a case (Figure 4).

For Lacan, the symptom is the fixed manner in which subjects enjoy their unconscious. Thus, the path that leads to oedipal normalization, even if it is neurotic, is also clearly marked. Treatment aims not at such a normalization but rather at learning “what to do with the symptom” instead of enjoying it.

VALENTIN NUSINOVICI

*See also:* Aimée, case of; Formations of the unconscious; Four discourses; Imaginary identification/symbolic identification; Metaphor; Real, the (Lacan); Signifier/signified; Subject’s desire; Topology.

FIGURE 4

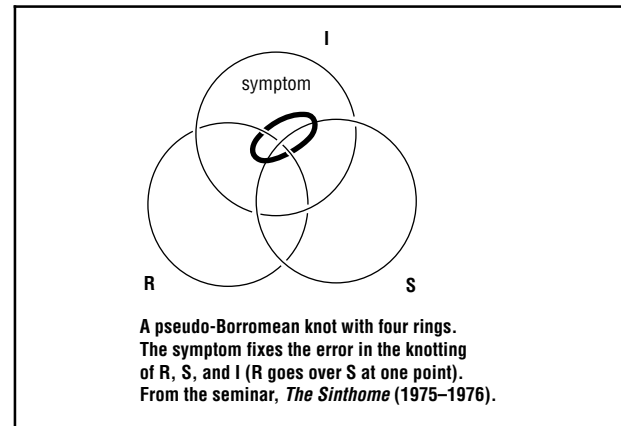

### Bibliography

- Lacan, Jacques. (1974–1975). *Le séminaire*. Book 22: *R.S.I. Ornicar?*, 2–5.
- . (1975). La troisième, intervention de J. Lacan le 31 octobre 1974. *Lettres de l'École Freudienne*, 16, 178–203.
- . (1975–1976). *Le séminaire*. Book 23: *Le sinthome. Ornicar?*, 6–11.
- . (1995). The position of the unconscious (Bruce Fink, Trans.). In Richard Feldstein, Bruce Fink, and Maire Jaanus (Eds.), *Reading “Seminar XI”: Lacan’s four fundamental concepts of psychoanalysis*. New York: W. W. Norton. (Original work published 1960)
- . (2001). Joyce: Le symptôme. In his *Autres écrits*. Paris: Seuil.
- . (2002a). The function and field of speech and language in psychoanalysis. In his *Écrits: A selection* (Bruce Fink, Trans.). New York: W. W. Norton. (Original work published 1953)
- . (2002b). The instance of the letter in the unconscious, or reason since Freud. In his *Écrits: A selection* (Bruce Fink, Trans.). New York: W. W. Norton. (Original work published 1957)

## SYNCHRONICITY (ANALYTICAL PSYCHOLOGY)

Carl Jung offered synchronicity as an acausal “principle of explanation” to account for “certain remarkable manifestations of the unconscious.” He saw the principle of synchronicity as an addition to the principle of psychic causality, which Freud had emphasized so strongly.

Jung “found that there are psychic parallelisms which simply cannot be related to each other causally,” such as “the simultaneous occurrence of identical thoughts, symbolism or psychic states” in analyst and analysand. In cultural history, one can also observe uncanny parallels, such as the coincidence of Chinese and European periods of style pointed out by Jung’s friend Richard Wilhelm, the German translator of the Confucian classic *I Ching* (Book of changes; also romanized as *Yijing*). This ancient book of wisdom has been used throughout its history as an oracle. Jung tested Wilhelm’s translation by counting out yarrow stalks and tossing coins—the traditional chance operations of Chinese divination—to locate specific chapters and verses in the *I Ching*, which he found would speak, like well-timed analytic interpretations, to his psychological situation at the time.

In his memorial to Wilhelm in 1930, Jung enunciated the synchronistic principle as an explanation. But it was not until the 1951 Eranos Conference that he fully described the “meaningful coincidence” and other sorts of facts that the concept “is intended to cover.” “Synchronicity: An Acausal connecting principle,” Jung’s full-blown development of the notion, appeared, together with an article by Nobel Prize-winning physicist Wolfgang Pauli, in German in 1952. There Jung offers synchronicity as a law of nature as important as the laws of causality and chance, which it supplements in governing the connections of events. Jung quotes Schopenhauer (2000): “All the events in a man’s life would accordingly stand in two fundamentally different kinds of connection: firstly, in the objective, causal connection of the natural process; secondly, in a subjective connection which exists only in relation to the individual who experiences it, and which is thus as subjective as his own dreams.” Jung understood this “subjective connection” to be the significance a subject finds in the linkage of events, but he located this meaning beyond the subject experiencing it in the psychoid nature of the archetypes themselves. An archetype, for Jung, is a field of meaning in the unconscious that may be registered simultaneously as a psychic event in the mind and as a physical reality in the outer world. As Robert Aziz (1990) has noted, such “simultaneity” need not mean occurring at the exact same moment of time; it is enough that events having a common meaning be linked without a plausible causal sequence. One of Jung’s favorite examples of such a meaningful coincidence occurred while he was analyzing a young woman patient. She was telling a dream in which she was given a golden scarab. Jung

heard a flying insect knocking against the window-pane, opened the window, and caught the creature—a scarabaeid beetle. This unexpected concretization of her fantasy helped his patient give up an intellectual defense against psychic reality that had kept her analysis from becoming a transformative experience, the scarab being, in Egyptian mythology, a classic symbol of rebirth. For a synchronicity to enhance consciousness rather than merely build up superstitiousness, it is important that the individual grasp its compensatory meaning.

JOHN BEEBE

*See also:* Archetype (analytical psychology); Need for causality; Psychic causality.

### Bibliography

- Aziz, Robert. (1990). *C. G. Jung’s psychology of religion and synchronicity*. Albany: State University of New York Press.
- Jung, Carl Gustav. (1930). Richard Wilhelm: In memoriam. In his *Collected works* (Vol. 15). London: Routledge and Kegan Paul.
- . (1950). Foreword to the *I Ching*. In his *Collected works* (Vol. 11). London: Routledge and Kegan Paul.
- . (1952b). Synchronicity: An acausal connecting principle. In his *Collected works* (Vol. 8). London: Routledge and Kegan Paul.
- Schopenhauer, Arthur. (2000). Die Transzendente Spekulation über die anscheinende Absichtlichkeit im Schicksal des Einzelnen In *Parerga and paralipomena: Short philosophical essays* (E. F. J. Payne, Trans.). New York: Oxford University Press. (Original work published 1851)

---

## SYSTEM/SYSTEMIC

A *system* is a self-regulating complex of interactive elements. It is a general model. Applied to the group or family as a unit, this notion is the basis for the systemic perspective.

In the United States the Palo Alto researchers (Gregory Bateson, Paul Watzlawick), using cybernetic and systems theory, studied the modalities of communications in the families of schizophrenics. They created notions such as the double bind, the paradox, and the existence of the “identified patient” (IP; the family member in whom the family’s symptom has emerged or is most apparent) necessary to the maintenance of family homeostasis. These new concepts have been

used in treating dysfunctional families using various “systemic family therapies.”

The first-generation systems theorists who used and developed the ideas of the Palo Alto group challenged psychoanalytic theories. Implementing a logic that is circular rather than linear, sessions relied on positive connotations, counter-paradoxes, and behavioral prescriptions. In this treatment option, intrapsychic phenomena were not denied but were deliberately disregarded. The emphasis was placed on information seen as “input” to and “output” from the “black box,” whose contents and workings were intentionally ignored. Further developments in theory and practice in this area have led to a taking into account of the effects produced by the presence and personality of the practitioner.

FRANÇOISE DIOT AND JOSEPH VILLIER

*See also:* Science and psychoanalysis.

### **Bibliography**

- Bertalanffy, Ludwig von. (1973). *General system theory: Foundations, development, applications*. New York: G. Braziller. (Original work published 1947)
- Le Moigne, Jean-Louis. (1977). *La théorie du système général: Théorie de la modélisation*. Paris: Presses Universitaires de France.
- Miermont, Jacques. (1985). Mythes et modèles scientifiques en psychothérapie individuelle et en thérapie familiale. *Actualités psychiatriques*, 9.
- Selvini-Palazzoli, Mara, Boscolo, Luigi, Cecchin, Gianfranco, et al. (1975). *Paradox and counterparadox: A new model in the therapy of the family in schizophrenic transaction* (Elisabeth V. Burt, Trans.). New York: J. Aronson.
- Wiener, Norbert. (1950). *The human use of human beings: Cybernetics and society*. Boston: Houghton Mifflin.

---

## **SZONDI, LEOPOLD (1893–1986)**

The Hungarian physician, psychopathologist, and psychoanalyst Leopold (or Lipot) Szondi was born in the Slovakian city of Nitra (then in Hungary) on March 11, 1893, and died on January 24, 1986 in Küsnacht, near Zurich.

In 1898, Szondi’s family moved to Budapest, where Leopold was an excellent student, first in Greek and Latin and subsequently in medical school at the Uni-

versity of Budapest. He was fascinated by Dostoevsky and Freud, and *The Interpretation of Dreams* became his vade mecum at the front during World War I. In 1919, as neuropsychiatrist and assistant to Paul Ranschburg, he published a series of analyses of personality based on constitutional and genetic factors; from 1921, he worked in private practice.

In charge of the state orthopedagogy program for secondary education from 1924 to 1927, Szondi served as professor of psychopathology at Pazmany-Peter University Medical School and also served as director of the Royal Hungarian Institute for Psychopathology and Psychotherapy. A decade of research followed together with self-analysis in which Szondi developed his method as an extension of psychoanalysis. That and regular contact with Imre Hermann moved Szondi beyond his earlier work on the constitutional and genetic bases of personality and destiny to psychoanalysis and the concept of the “familial unconscious.” Shortly after publication of an investigation of marriage in 1937, which won Freud’s stamp of approval, anti-Semitic legislation enacted by the pro-Nazi Hungarian government doomed Szondi’s laboratory.

Dismissed from his state appointments in 1941, Szondi was eventually banned from practicing privately; in 1944 he was deported with his wife and two children to Bergen-Belsen; eventually released, he found refuge in Switzerland. He spent some months as a psychotherapist at the Forel Clinic in Prangins before settling in Zurich in 1946. Excluded from academic psychiatry, he continued his practice, wrote, and trained students from Switzerland and abroad through analysis and supervision.

An international research association was created, today known as the Szondi Society; beginning in Zurich in 1957, it organized triennial symposiums. Funding enabled foundation of the Szondi Institute in 1969. The recipient of honorary degrees from the University of Louvain in 1970 and the University of Paris in 1979, Szondi continued to work as long as his health permitted, dying in 1986 in a nursing home near Zurich.

Although remembered as inventor of a simple and controversial projective test, Szondi always conceived of his technique as an adjuvant to *Shicksalanalyse* (Fate Analysis) which was inspired by depth analysis. Five large volumes formed the discipline’s basic program. *Shicksalanalyse* (1944) presented results of laboratory

research that aimed to reveal how people are motivated to make the “choices in love, friendship, professions, illness and death” that determine personal destiny. The test that was developed from this work was published in 1947, and translated into English in 1952 as *Experimental Diagnostics of Drives*.

Freud's influence, already present in Szondi's thinking, would be further manifest in subsequent work in Zurich. *Triebpathologie* (Drive pathology; 1952), aimed to move classical descriptive psychiatry in a psychoanalytic direction. *Triebpathologie II* appeared in 1956, dedicated to Freud on the occasion of the centenary of his birth, fulfilling his wish that one day successors would carry on an analysis much as he had done with sexuality. Finally, *Schickalanalytische Therapie* (Fate Analysis Therapy), published in 1963, used a Freudian cast to investigate problems associated with active techniques (such as Ferenczi had employed) and the application of analysis to psychosis and mood disorders. Szondi's work in later years included articles in various reviews and *Szondiana*, and, most memorably, the complementary volumes in which he reprised his theme of paroxysmality as clarified by the contrasting figures of the murderer *Kain* (Cain; 1969) and the law-giver *Mose* (Moses; 1973).

For a variety of reasons, Szondian analysis has remained fairly obscure. To the effects of war and relocation in Switzerland, which occurred just as his research was moving him toward a radical shift in perspective, must be added the occultation of the work due to reception of the test and some difficulty on Szondi's part in clearly describing that change, together with its new foundation. Finally, Szondi's

clinical genius and the effective range of his work were obvious only to patients and disciples with whom he had a close relationship in Zurich. Some followers took it upon themselves to lay a new foundation for his work; with a presence at university centers in Louvain and Liège, Szondian analysis at last found indispensable ground for further development and the opportunity to better explain and propagate the core of his teaching—paradoxically, primarily in francophone and Latin countries. Szondi, by moving beyond his own test, brings us to a broad view of his work as constituting the most significant attempt yet to create a global psychiatry undergirded by the spirit of psychoanalytic thought.

JACQUES SCHOTTE

*See also:* Psychological tests.

### **Bibliography**

- Lekeuche, Philippe, and Mélon, Jean. (1990). *Dialectique des pulsions*. Bruxelles: De Boeck-Université.
- Schotte, Jacques. (1990). *Szondi avec Freud: Sur la voie d'une psychiatrie pulsionnelle*. Bruxelles: De Boeck-Université.
- Szondi, Leopold. (1965). *Schicksanalyse*. Basel and Stuttgart: Benno Schwabe, five volumes, 1965; Bern: Hans Hubert, 1952, 1956, 1960, 1963.
- . (1969). *Kain. Gestalten des Bösen*. Bern: Hans Huber.
- . (1973). *Moses: Antwort auf Kain*. Bern: Hans Huber.
- Szondi, Lipot. (1952). *Experimental diagnostics of drives*. New York: Grune and Stratton.

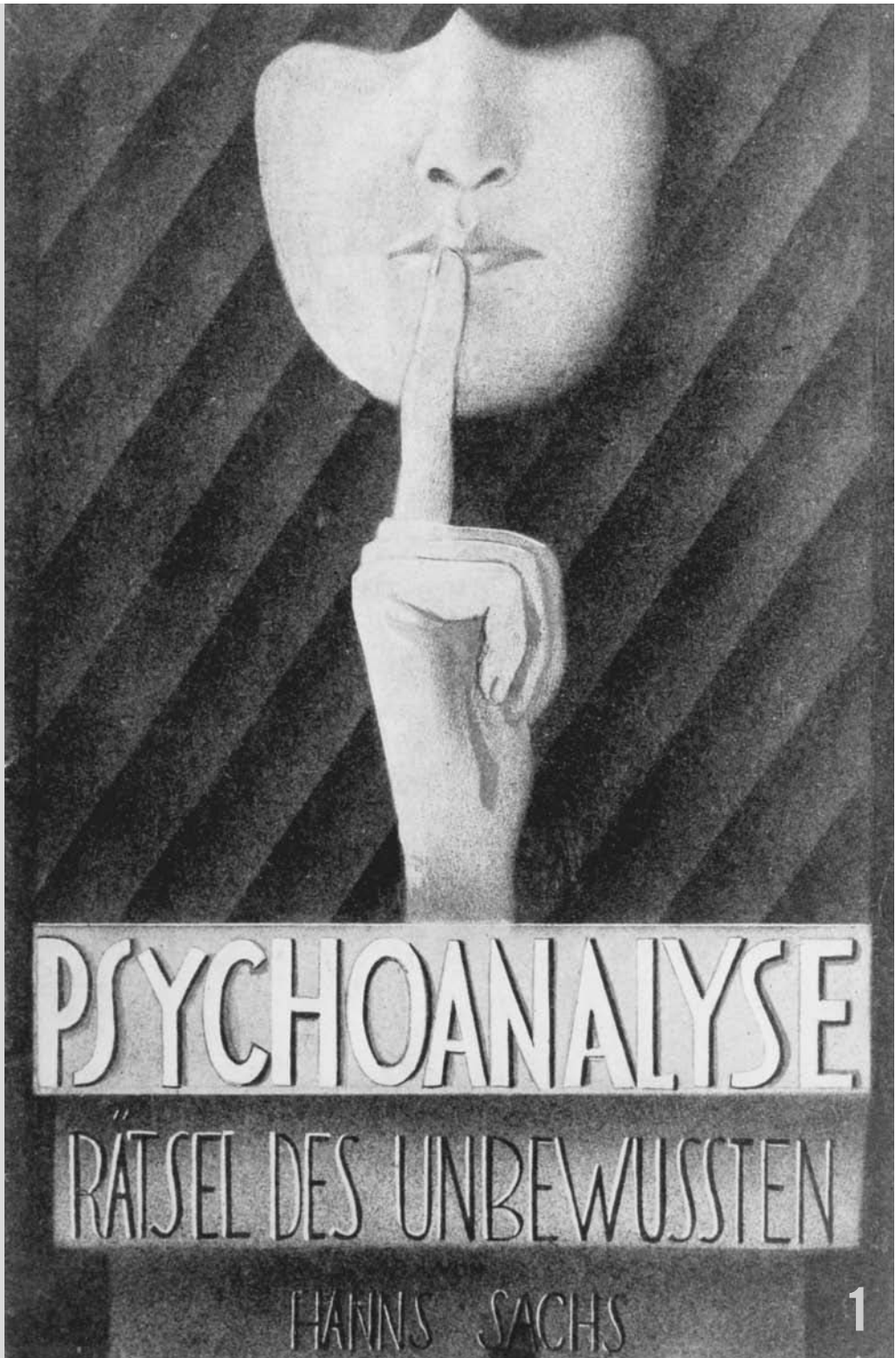

**one:** Poster for film *Psychoanalyse*. The subtitle "Rätsel des Unbewussten" translates to "Riddle of the Unconscious." *Mary Evans Picture Library. Reproduced by permission.*



**two:** Oskar Pfister (1873–1956), Swiss pastor, teacher, and psychoanalyst. Pfister was one of the first lay analysts, and his impact on the field has been recognized by the American Psychiatric Society, which awards the Oskar Pfister Prize for outstanding contributions to the psychology of religion. *Public Domain. Courtesy of New York Psychoanalytic Institute and Society.* **three:** James Putnam (1846–1918), American neurologist. Putnam, at Freud's insistence, initiated the establishment of both the American Psychoanalytic Association and the Boston Psychoanalytic Society. *Courtesy of the New York Psychoanalytic Institute and Society. Reproduced by permission.* **four:** Otto Rank (1884–1939), Austrian psychologist and psychoanalyst. Second only to Freud in the number of published works on psychoanalysis, Rank was the author of *The Trauma of Birth*, and the first person to be awarded a PhD based on a psychoanalytic thesis. *Photo by Hulton Archive/Getty Images. Reproduced by permission.*





5



6

**five:** Wilhelm Reich (1897–1957), Austrian physician and psychoanalyst. Reich discovered "orgone energy," which he considered life energy, closely related to the function of orgasm. Reich also authored *The Mass Psychology of Fascism* and *Character Analysis*—his most important works. *Courtesy of the New York Psychoanalytic Institute and Society. Reproduced by permission.* **six:** Theodor Reik (1888–1969), Austrian psychologist and lay psychoanalyst, founder of the National Psychological Association for Psychoanalysis. *Public Domain. Courtesy of the New York Psychoanalytic Institute and Society.* **seven:** Hermann Rorschach (1884–1922), Swiss psychoanalyst and creator of the Rorschach inkblot projective test. *Public Domain. Courtesy of the New York Psychoanalytic Institute and Society.*





**eight:** Hanns Sachs (1881–1947), Austrian lawyer and psychoanalyst. Sachs was a loyal disciple of Freud as well as co-founder of *Imago*. He chose the name for the journal. Sachs invested much effort in trying to popularize psychoanalysis. *Public Domain. Courtesy of the New York Psychoanalytic Institute and Society.* **nine:** The "Secret Committee." Back row from left: Otto Rank, Karl Abraham, Max Eitingon, and Ernest Jones. Front row from left: Freud, Sandor Ferenczi, and Hanns Sachs. © Bettmann/Corbis. Reproduced by permission.



8

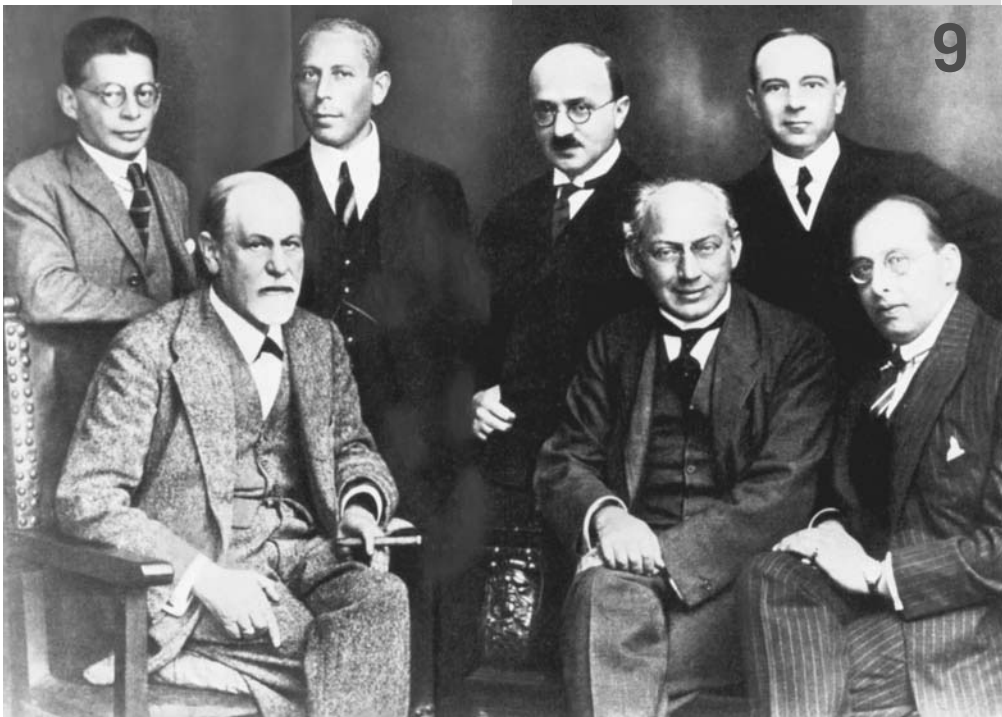



**ten:** Freud's office, complete with couch, as it has been preserved in the Sigmund Freud Museum, which was the Freud family's home at Berggasse 19 in Vienna. © Peter Aprahamian/Corbis. *Reproduced by permission.* **eleven:** Leo Stone (1904–1997), American psychoanalyst and teacher. Stone advocated using psychoanalysis to treat a wide variety of illnesses and was a proponent of the "flexible approach" by analysts, an idea that was, at one time, considered a radical concept. *Courtesy of the New York Psychoanalytic Institute and Society. Reproduced by permission.*

12



**twelve:** Alix Strachey (1892–1973), British psychoanalyst. Strachey assisted her husband James in the translation of Freud's works. She also translated the work of other psychoanalytic pioneers such as Karl Abraham and Melanie Klein. *Photo by Frances Partridge/Getty Images.* **thirteen:** James Strachey (1887–1967), British psychoanalyst and translator and editor of *The Standard Edition of the Complete Works of Sigmund Freud*. *Photograph of James Strachey, Int. J. Psycho-Anal. (1969), 50: 132. © Institute of Psychoanalysis, London, UK. Reproduced by permission.*



13



14

**fourteen:** Harry Stack Sullivan (1892–1949), American psychiatrist. Sullivan was a charter member of the Washington Psychoanalytic Society who later left psychoanalysis to establish the Washington School of Psychiatry and the journal *Psychiatry*. *The Library of Congress. Reproduced by permission.* **fifteen:** Leopold Szondi (1893–1986), Hungarian psychoanalyst and inventor of *Shicksanalyse* and the Szondi projective test. *Photo by Yale Joel/Time Life Pictures/Getty Images. Reproduced by permission.*

15

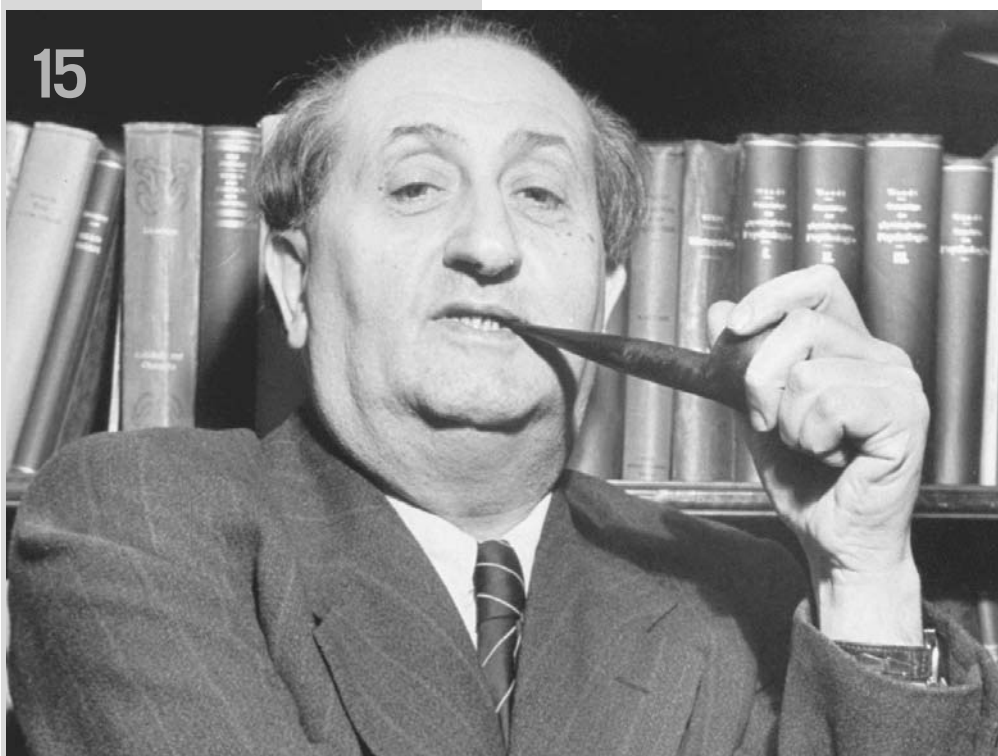



16



17



18

**sixteen:** Julius Wagner-Jauregg (1857–1940), front row center, Austrian psychiatry professor and 1927 Nobel Laureate in physiology and medicine with his staff in 1927. *Public Domain. Courtesy of the New York Psychoanalytic Institute and Society.* **seventeen:** Fritz Wittels (1880–1950), Austrian physician and psychoanalyst. Wittels spent a good part of his psychoanalytic career in the United States where he taught at the New School, became a member of the American Psychoanalytic Association, and was associated with Bellevue Hospital and Columbia University in New York City. *Public Domain. Courtesy of the New York Psychoanalytic Institute and Society.* **eighteen:** Donald Woods Winnicott (1896–1971), British pediatrician and psychoanalyst. Winnicott was a co-founder of the "British Object Relations School." *Courtesy of the International Association for the History of Psychoanalysis. Reproduced by permission.*

# T

## TABOO

The word *taboo* was borrowed by Captain Cook, in 1769, from the Polynesian language spoken in the Hawaiian Islands. A report of his voyage was published in 1884 but the word appeared earlier in Europe in the narratives of expeditions by Adam J. von Krusenstern, 1802, and by Otto von Kotzebue, 1817. They reported on the number and variety of prohibitions the word *taboo* refers to. Cook further specified that *taboo* was applied to anything forbidden to the touch. British anthropology took over the term, subsequently reworked by the German schools on the psychologies of various peoples, and the French schools of sociology. Freud later made use of this work to define taboo as an adjective with opposite meanings—simultaneously sacred and consecrated, as well as dangerous, forbidden, impure. Taboo was the name for prohibitions that were self-imposed along with their sanctions in the event of transgression, and which lacked meaning or any obvious referent. Anyone who violated a taboo was also taboo, which illustrates the taboo's power of contagion.

The term *taboo* appears in a short text of Freud's entitled "The Significance of Sequences of Vowels" (1911d), which discusses the names of God in Hebrew. "Taboo and Emotional Ambivalence," the second chapter of *Totem and Taboo* (1912–13a), was published in 1912. This work continues an earlier investigation into obsessional neurosis, the analogy between its symptoms and religious rites, and the psychology of religion ("Obsessive Actions and Religious Rites," 1907b). Freud also published "The Antithetical Meaning of Primal Words" (1910e), with *taboo* being one such example. Thus Freud's studies on taboo are limited in scope,

inserted into a broader investigation that was to be further elaborated in Freud's larger works on collective psychology, especially *The Future of an Illusion* (1927c), *Civilization and Its Discontents* (1930a [1929]), and *Moses and Monotheism* (1939a [1934–38]).

Freud associated taboo with ambivalence from the start. As early as the preface to *Totem and Taboo*, he writes that "the analysis of taboos is put forward as an assured and exhaustive attempt at the solution of the problem" (1912–13a, p. xiv) (as opposed to the totem), whose differences with taboo he goes on to point out. "The difference is related to the fact that taboos still exist among us. . . . They do not differ in their psychological nature from Kant's 'categorical imperative,' which operates in a compulsive fashion and rejects any conscious motives" (p. xiv). However Freud introduces fresh complications into this idea by postulating for the first time, in the chapter "Taboo and Emotional Ambivalence," the existence of a primal ambivalence of emotions which the taboo's prohibitions express. Freud then relates their existence to totemism: "The most ancient and important taboo prohibitions are the two basic laws of totemism: not to kill the totem animal and to avoid sexual intercourse with members of the totem clan of the opposite sex" (p. 31–32). Still this ambivalence becomes apparent as totemism only after the murder of the primal father, in the first acts of mourning and the transition to the totemic clan. The hypothesis of life and death drives could be used to make the taboo autonomous, which Freud does not do. Therefore, the taboo's existence is secondary, and follows upon that of the totem: given the thesis of totemism and the persistence of unconscious wishes, the "must not" is really a form of "must no longer." "The basis of taboo is a prohibited action,

the performing of which a strong inclination exists in the unconscious. . . . There is no need to prohibit what no one desires to do” (p. 32). The analogy with obsessional neurosis enabled Freud to clarify the dynamics of conflict and the topographical structure that gives rise to the existence of taboos: “I will now sum up the respects in which light has been thrown on the nature of taboo by comparing it with the obsessional prohibitions of neurotics. Taboo is a primaevial prohibition forcibly imposed (by some authority) from outside, and directed against the most powerful longings to which human beings are subject. The desire to violate it persists in their unconscious; those who obey the taboo have an ambivalent attitude to what the taboo prohibits. The magical power that is attributed to taboo is based on the capacity for arousing temptation; and it acts like a contagion because examples are contagious and because the prohibited desire in the unconscious shifts from one thing to another. The fact that the violation of a taboo can be atoned for by a renunciation shows that renunciation lies at the basis of obedience to taboo” (pp. 34–35). Therefore, “taboo conscience is probably the earliest form in which the phenomenon of conscience is met with” (p. 67).

The analysis of taboos touches on a number of themes. As psychic formations actualizing a dynamic of unconscious conflict amongst drive-impulses, they make use of primary processes; the propagation of this dynamism based on representations of contiguity and similarity—touch for the Unconscious—is clear and further elucidates the contagion, the “mana” of taboo as well as “delusions of touching.” At the same time these psychic formations attribute hatred and dangerousness to taboo objects and enable us to analyze projection. Moreover the conviction the taboo entails, owing to its dependence on the Unconscious, points toward animism, magic, and the omnipotence of thought—in short, to a study of narcissism. And the analogy, almost the identity, between the forms and dynamics of individual rites and rituals and those associated with taboos makes them a key element in the connection Freud creates between individual and collective psychology. The primal conflict of ambivalence that taboo allows us to postulate relates it to the hypothesis of the life and death drives, and the troubles encountered by moral conscience: anxiety, guilt, the superego, as well as their genesis via the primal murder. Even if *Totem and Taboo* “exhausts the problem” of taboo, Freud’s later work modified our viewpoint of it. Freud’s proposed analysis of the feminine in “The

Taboo of Virginity” (1918a) transforms the concept of taboo. Whereas the ambivalence of those subject to the taboo was in general the cause for prohibitions and prescriptions; in the case of the young girl to be deflowered, it is the real danger she represents (penis envy, revenge) that makes her taboo for others.

When anthropologists rejected the universalist perspective Freud invoked, the concept of taboo became subject to criticism. The structuralist viewpoint interpreted all taboos for *each* society as a single global symbolic system of classification, organization, and interpretation of the real, independently of any possibility for dynamic change—a claim taken up by the structuralist movement in psychoanalysis. The renewal of studies into dynamic change in the exact sciences may renew interest in Freud’s works on this subject.

MICHÈLE PORTE

*See also:* Abel, Carl; Animistic thought; Anthropology and psychoanalysis; Childhood; Isolation (defense mechanism); Narcissism of minor differences; Obsessional neurosis; Rite and ritual; Smell, sense of; Structural theories; “Taboo of Virginity, The”; Totem/totemism; *Totem and Taboo*; Transgression.

### Bibliography

- Frazer, James G. (1951). *The golden bough; a study in comparative religion*. London: Macmillan. (Original work published 1890–1915)
- Freud, Sigmund. (1907b). Obsessive actions and religious practices. *SE*, 9: 115–127.
- . (1910e). The antithetical meaning of primal words. *SE*, 11: 153–161.
- . (1911d). The significance of sequences of vowels. *SE*, 12: 341.
- . (1912–13a). *Totem and taboo*. *SE*, 13: 1–161.
- . (1918a [1917]). The taboo of virginity. *SE*, 11: 191–208.

---

### “TABOO OF VIRGINITY, THE”

Freud presented “The Taboo of Virginity” to the Vienna Psychoanalytical Society on December 12, 1917. He published it in 1918 as the third of three

essays entitled “Contributions to the Psychology of Love” (*Beiträge zur Psychologie des Liebeslebens*), the first two of which were revisions of his earlier papers, “A Special Type of Choice of Object Made by Men” (1910h) and “On the Universal Tendency to Debasement in the Sphere of Love” (1912d).

By regrouping these papers under a common title, Freud wanted to express the continuity of his thought concerning love, including sexual attitudes and conduct. The 1910 article, appearing about the same time as his first explicit formulation of the Oedipus complex, is concerned principally with male conquest and rivalry with other men; two years later, the second essay addresses the problem of male impotence, with specific reference to the psychological dissociation of tender from sexual feelings. “The Taboo of Virginity” in certain respects complements the first two.

Freud begins by asking why a young women’s virginity is so highly valued in so many societies. He turns to anthropology to show that, in some groups, defloration is carried out just before the wedding ceremony by a third party officially charged with that duty. Such practices form part of the constraints that continue to regulate sexual life of all civilizations. In fact, “it cannot be disputed that a generalized dread of women is expressed in all these rules of avoidance. . . . The man is afraid of being weakened by the woman, infected with her femininity and of then showing himself incapable” (pp. 198–199). This fear is due to castration anxiety, from which arises the idea that women are “a source of such dangers, and the first act of sexual intercourse with a woman stands out as a danger of particular intensity” (p. 200). Women contribute to such dread by the persistence of their own oedipal and castration complexes, from which arise the burdens of sexual prohibition, penis envy, and “hostile embitterment” towards men, together with the fact that their desire remains fixated on the father, for which “[t]he husband is almost always so to speak only a substitute, never the right man” (p. 203). Defloration by a third party serves such conflicts in women as much as it wards off men’s fears. When such conflicts are particularly severe, they can help explain frigidity in women.

“The Taboo of Virginity” is thus an integral part of Freud’s work on the Oedipus complex and castration. As a text particularly concerned with the psychoanalytic view of female sexuality, it has occasioned much critical discussion (for example, Laplanche).

ROGER PERRON

*See also:* Castration complex; “Contributions to the Psychology of Love”; Fascination.

### Source Citation

Freud, Sigmund. (1918a [1917]). Das Tabu der Virginität (Beiträge zur Psychologie des Liebeslebens, III.). In *Sammlung kleiner Schriften zur Neurosenlehre* (Vol. IV, p. 229–251). Leipzig and Vienna: F. Deuticke; The taboo of virginity. *SE*, 11: 191–208.

### Bibliography

Freud, Sigmund. (1908d). “Civilized” sexual morality and modern nervous illness. *SE*, 9: 177–204.

———. (1910h). A special type of choice of object made by men. *SE*, 11: 163–175.

———. (1912d). On the universal tendency to debasement in the sphere of love. *SE*, 11: 177–190.

Laplanche, Jean. (1980). *Problématiques III, La Sublimation*. Paris: Presses Universitaires de France.

---

## TACT

The notion of *tact* is basic to psychoanalytic know-how, implicit in the work of Sigmund Freud, and explicit in that of Sándor Ferenczi. In France, for example, it was developed by Sacha Nacht under the category of “presence of the psychoanalyst.”

This deceptively simple notion, to which Ferenczi returned a number of times in articles he wrote near the end of his life, deserves to be discussed, as he himself did in his article of 1928, “The Elasticity of Psychoanalytic Technique”: When and how should something be communicated to the analysand? “It is above all a question of psychological tact,” he replied. “But what is ‘tact’? The answer is not very difficult. It is the capacity for empathy. If, with the aid of knowledge we have obtained from the dissection of many minds, but above all from the dissection of our own, we have succeeded in forming a picture of possible or probable associations of the patient’s of which he is still completely unaware, we, not having the patient’s resistances to contend with, are able to conjecture, not only his withheld thoughts, but trends of his of which he is unconscious” (p. 89).

Ferenczi supplemented the general import of this formulation, making it more widely applicable, because he had been treating patients, who, as a consequence



of early traumatism, were affected by a narcissistic split of the self. He postulated the parent-child interactions as the elements “which make the trauma pathogenic,” speaking particularly of parental disavowal: “Probably the worst way of dealing with such situations is to deny their existence, to assert that nothing has happened and that nothing is hurting the child. Sometimes he is actually beaten or scolded when he manifests traumatic paralysis of thought and movement. These are the kinds of treatment which make the trauma pathogenic” (1931, p. 138).

In 1932 Ferenczi wrote a corrosive little article whose title alone expressed clearly his insistence on not harming his patients who were in a state of regression: “Repetition in Analysis Worse than Original Trauma.” In such patients there is “self-sacrifice of one’s own mind’s *integrity* in order to save the parents!” (p. 268); the whole problematic of the idealization and sacrificial function of the mistreated and sexually abused child was again presented; but he insisted: “much *encouragement* is needed” (p. 138), much tact.

PIERRE SABOURIN

See also: Elasticity; Nacht, Sacha Emanoel; Technique with adults, psychoanalytic; Tenderness; “Wild’ Psycho-Analysis.”

### **Bibliography**

Ferenczi, Sándor. (1928). The elasticity of psycho-analytic technique. In *The selected papers of Sándor Ferenczi, Vol. 3*. (pp. 87–101) (Michael Balint, Ed.; Eric Mosbacher, et al, Trans.). New York: Basic Books.

———. (1931). Child analysis in the analysis of adults. In *The selected papers of Sándor Ferenczi, Vol. 3* (pp. 126–42). (Michael Balint, Ed.; Eric Mosbacher, et al, Trans.). New York: Basic Books.

———. (1932). Repetition in analysis worse than original trauma. In *The selected papers of Sándor Ferenczi, Vol. 3*. (Michael Balint, Ed.; Eric Mosbacher, et al, Trans.). New York: Basic Books, 268.

## **TAUSK, VIKTOR (1879–1919)**

Psychiatrist and psychoanalyst Viktor Tausk was born on March 12, 1879, in Zsilina, Slovakia, and committed suicide on July 3, 1919, in Vienna.

The eldest of nine children, Tausk came from a German-speaking, non-religious Jewish family that, soon after his birth, moved to Croatia. His parents had an unsuccessful marriage. His father, Hermann, was a bright, ambitious, and popular newspaperman, who at one point managed the press office of the government of Bosnia-Herzegovina. Tausk would oppose his father’s attachment to the Austro-Hungarian Empire by supporting the Yugoslavian nationalist movement and by becoming fluent in Serbo-Croatian.

Tausk, in fact, grew up hating his father while maintaining strong affection for his mother, Emilie. Brilliant in school and multilingual, he initially chose to study law rather than costly medical studies. At Mostar, where he practiced for a time as a lawyer’s assistant, he preferred to defend impoverished clients, not excepting accused murderers.

Tausk visited Vienna for the first time in 1897, and there in 1898 met Martha Frisch, a distant relation of Martin Buber, the theologian-philosopher and social activist. Jewish by birth and Marxist by persuasion, she was also a Christian, and Tausk was baptized in order to marry her in 1900. Their first child was stillborn, but a son, Marius, was born in 1902; a second son, Victor-Hugo, followed in 1904. They returned to Yugoslavia, where they separated in 1905 and divorced three years later.

Resettled in Berlin by 1906, Tausk began working as a journalist while writing poetry and plays and immersing himself in artistic endeavors. In 1907 his health, already precarious while a student, worsened with both physical illness (including weak lungs) and depression. He entered a sanatorium and during his stay was apparently impressed by an article by Freud, wrote to him, and received an invitation to study psychoanalysis in Vienna. There he moved in 1908 and began analytic training. He became interested in the psychoses just about the time of Carl Jung’s rupture with Freud; the former had published *The Psychology of Dementia Praecox* in 1907.

At the same time, Tausk began medical studies, due to financial help he received from Freud and other Viennese analysts. He worked both at the outpatient neurological department directed by Frankl von Hochwart and at the psychiatric clinic at the University of Vienna, presided over by Wagner von Jauregg, the psychiatrist and neurologist who would later win a Nobel Prize. Tausk obtained his medical degree in 1913.

Lou Andreas-Salomé, highly reputed among intellectuals, met Tausk in 1912; she admired his brilliance while perceiving the extent of his psychological conflicts. (Kurt R. Eissler suggested a retrospective diagnosis of manic-depressive illness.) Analysts at the time were not required to undergo a personal psychoanalysis, which in any event was more often didactic than therapeutic. The facts concerning the presumed affair between Tausk and Andrea-Salomé are controversial.

In 1915 Tausk was mobilized and served as a psychiatrist in Lublin. Although he continued to attend psychoanalytic meetings, the dreadful economic conditions in Europe at the end of World War I found Tausk living like an impoverished student. He had opportunities for work in Belgrade and Zagreb but did not want to leave Vienna. Freud declined to accept Tausk as an analysand and referred him to Helene Deutsch. But Deutsch found that treating Tausk contaminated her own sessions with Freud, who instructed her to choose between himself and Tausk (Roazen, Paul, 1972, p 31). Three months later, in 1918, she terminated Tausk's analysis.

On the question of Tausk's suicide, Paul Roazen has stressed the impact of his conflicts with Freud, which he viewed as based on deep-seated rivalries, including issues of plagiarism and intellectual priority of ideas. Eissler by contrast emphasized Tausk's "severe" psychopathology, qualifying him as "talented" but no "genius." However disturbed he may have been, he impressed Melanie Klein when she met him at the Budapest Congress in 1918.

Tausk, in any event, ended his own life by shooting himself in the head after wrapping a curtain cord around his neck, so that he strangled himself as he fell. He had been drinking, but a rumor of his prior emasculation was unfounded. Though attractive to women, Tausk's affairs had often ended in failure and abandonment. Before his death he had become engaged to Hilde Loewi, a young concert pianist whom he seduced while his patient. She may have been pregnant with his child when he committed suicide.

Tausk's fourteen published articles are remarkable for adumbrating certain psychoanalytic concepts. The best known is "On the Origin of the 'Influencing Machine' in Schizophrenia" (1919), the last of his writings to be published during his lifetime. Indeed, after his death Tausk curiously disappeared from the psychoanalytic horizon, only to return in the 1970s.

Tausk's actual influence has been indirect and often gone unattributed, consonant with his posthumous occultation in the history of psychoanalysis.

MARIE-THERÈSE NEYRAUT-SUTTERMAN

*See also:* Hungary; Suicide.

### **Bibliography**

- Eissler, Kurt R. (1971). *Talent and genius*. New York: Quadrangle Books.
- Kanzer, Mark. (1972). Victor Tausk—The creativity and suicide of a psychoanalyst. *Psychoanalytic Quarterly*, 41, 556–584.
- Roazen, Paul. (1969). *Brother animal. The story of Freud and Tausk*. New York: Alfred Knopf.
- . (1969). Victor Tausk's contribution to psychoanalysis. *Psychoanalytic Quarterly*, 38, 349–353.
- Tausk, Marius. (1973). Viktor Tausk as seen by his son. *American Imago*, 30 (4), 323–335.
- Tausk, Viktor. (1991). *Sexuality, war, and schizophrenia: Collected psychoanalytic papers*. New Brunswick, NJ: Transaction.

---

## **TAVISTOCK CLINIC**

The Tavistock Clinic, also called the "Tavi," is the premier psycho-dynamic psychiatric out-patient clinic in the British Isles, with Health Service departments for adults, adolescents, and children and families. It provides consultations to other institutions. The Academic Services Directorate provides post-graduate trainings. Human development, inter-personal relationships within families and social structures are researched. The chief executive in 2005 was Nicholas Temple.

The Tavistock Clinic was opened in 1920 at No. 51, Tavistock Square, Bloomsbury, London, by Hugh Crichton-Miller, who had used Freud's theory of neurosis in the treatment of soldiers suffering "shell shock" from the First World War.

Crichton-Miller was a Christian influenced by Jung and Freud. The clinic embraced a wide range of psychological approaches, and applied psychoanalysis and eclectic training, which resulted in a mutual antipathy with Ernest Jones, who officially banned psychoanalysts from staffing the clinic.

Staff and trainees undertaking psychoanalytic training later were Wilfred Bion, Margaret Little, Clara Thompson, C. Phillip Wilson, and Eric Wittkower. Michael Fordham trained with the Jungians. A few psychoanalysts, including Susan Isaacs and Karin Stephen, took part in the clinic's training.

During the World War Two, several staff members served in the Armed Forces; J. R. Rees becoming chief of Army psychiatric services, G. R. Hargreaves Assistant Director of Army Psychiatry. They brought together Bion, John Bowlby, Bridger, Dicks, Foulkes, Kelnar, MacKeith, Main, Morris, Phillipson, Rickman, Rodger, Trist, Wilson, and Wittkower, forming an "invisible college" working on officer selection, training, morale, civil resettlement, therapeutic communities, and group therapy. In 1946 some of these formed the Tavistock Institute of Human Relations (TIHR), an interdisciplinary group interested in the problems of organizational and societal change. This group established a journal, *Human Relations*, and Tavistock Publications Ltd. With the Family Welfare Association (Enid Eicholz, later Balint) they created the Family Discussion Bureau (Tavistock Marital Studies Institute). In the clinic they established a unit for adolescents, developed the School of Family Psychiatry and Community Mental Health (Academic Services Directorate) and the joint Library.

The relationship between the clinic and psychoanalysis improved after the war, due to the work of John Rickman and Sylvia Payne. Bowlby headed the children's department and John Sutherland became medical director. Michael Balint joined in 1949. Many staff and trainees were in psychoanalytic training. The adult department focused on group-analytic therapy and the children's department on the total family. Bion wrote on groups, Dicks on marital difficulties, Malan on short-term psychotherapy, Sandler on the psychodynamic personality inventory, Parkes on bereavement, Laing on pathological family processes, Ainsworth on attachment, Bowlby on attachment and loss, and the Robertsons made films on separation. Training for lay child-psychotherapists was set up by Bowlby with Esther Bick and Martha Harris.

The clinic, with TIHR, moved to new premises in 1967, also housing the Child Guidance Training Center. The adolescent unit incorporated the Young People's Consultation Service headed by Walter Joffe.

The present-day clinic provides service, training, and research, complementary to psychoanalysis, and attracts visitors and trainees from afar.

MARCUS JOHNS

*See also:* Balint group; Bick, Esther; Bion, Wilfred Ruprecht; Bowlby, Edward John Mostyn; British Psycho-Analytical Society; Great Britain; Infant observation (therapeutic); Laing, Ronald David; Rees, John Rawlings; Rickman, John; Robertson, James; Technique with children, psychoanalytic; Tustin, Frances.

### **Bibliography**

- King, Pearl H. M. (1989). British analysts during World War II. Inter-disciplinary collaboration. *International Review of Psychoanalysis*, 16, 15–34.
- Trist, Eric; et al. (1982). The Tavistock Institute: origin and early years. *Personal communication* (pp. 1–30). New York: Pearl King, Academy of Management.

---

## **TECHNIQUE WITH ADULTS, PSYCHOANALYTIC**

The difficulties Freud experienced in writing the *General Method of Psychoanalysis* ("Allgemeine Methodik der Psychoanalyse"), which he had announced in 1908 to Carl G. Jung, Sándor Ferenczi, Karl Abraham, and Ernest Jones, are well known. The need for such a manual had become more urgent by 1906, as more students and colleagues showed interest in being initiated into the new method of treatment. Scattered in cities across the world—Zurich, Budapest, London, New York, and Toronto—these followers were busy with their professional responsibilities, and so were unable to complete an apprenticeship under the personal tutelage of the sole master of psychoanalysis.

Freud did not get much past page 36, and it was only after 1910 that he decided to publish the few articles that, until 1915, were generally grouped under his "technical writings." These involved merely a few recommendations, generally of the nature of what should *not* be done during treatment, lessons learned from years of slow and progressive elaboration of the psychoanalytic method.

The history of Freud's method was marked by some important turning points, especially the progressive abandonment of hypnosis, the substitution of free

association for the technique of concentration (1898a), the stress on the interpretation of dreams (1900a), and the emphasis on the analysis of resistance rather than the forced search for “primal scenes,” in addition to the primordial role eventually accorded to transference neurosis.

Although the framework of the treatment was in place from 1903, at least in its formal aspect (1904a [1903], 1905a [1904]), it was only in October 1907, with the treatment of the “Rat Man” (1909d) that the last great technical recommendation was announced: “The technique of analysis has changed to the extent that the psychoanalyst no longer seeks to elicit material in which he is interested, but permits the patient to follow his natural and spontaneous trains of thought” (Nunberg and Federn, p. 227).

While questions were raised concerning possible modifications of technique to include psychotic patients, the First World War and its social implications led Freud to anticipate the need to mix the practical aspects of psychotherapy with the ideals of classical psychoanalysis (1919a [1918]), paving the way for multiple modifications in technique, which appeared one after another in the years to come.

Salient among the first modifications were Ferenczi’s experiments with “active technique,” which, following Freud’s example, he pushed at first to an extreme, in opposition to what he denounced as the “fanaticism of interpretation.” The work which he published in 1924 with Otto Rank, *Perspectives de la psychanalyse* (Perspectives on psychoanalysis), was less shocking for the public than the theory that Rank espoused shortly afterwards in *The Trauma of Birth*, but both Rank and Ferenczi aimed at reducing the length of treatments, and bringing to greater prominence the maternal role of the analyst in the transference. In April, 1926, Rank distanced himself even further from Freud with his book *Technik der Psychoanalyse* (Technique of psychoanalysis), and in the 1930s, Ferenczi did likewise, especially with his emphasis on [sexually] gratifying behavior, and his experiments with “reciprocal analysis.”

On the other hand, Abraham, Ernst Simmel, and Max Eitingon, at the Berlin Polyclinic and Institute, which they created in 1920, codified the technical rules that were to be taught to candidates in psychoanalytic training, based on a “didactic analysis” and supervision. These continue to constitute the basis of teaching at most psychoanalytic institutes.

Among the significant technical “innovations” was doubtless “character analysis,” which Wilhelm Reich developed in 1933, and which marked the last great discussions contemporaneous with Freud, apart from the debates concerning analytical technique with children that took place between the disciples of Anna Freud and Melanie Klein. After the war, Jacques Lacan’s suggestion to permit sessions varying in length was severely censured by the members of the International Psychoanalytic Association, without discussion, its originator not having supplied sufficient supporting materials for such a proposal.

In the area of classic analytic treatment, modifications multiplied, along with the creation of new techniques loosely connected with psychoanalysis: “psychoanalytically oriented psychotherapy,” psychodrama, group psychoanalysis, and so forth.

Freud himself never established rules that were fixed and absolute, commenting even, in introducing his “Recommendations”: “The technical rules that I am putting forward here have been arrived at from my own experience in the course of many years, after unfortunate results had led me to abandon other methods. . . . I must however make it clear that what I am asserting is that this technique is the only one suited to my individuality; I do not venture to deny that a physician quite differently constituted might find himself driven to adopt a different attitude to his patients and to the task before him” (1912e, p. 111).

A reading of the memoirs of his analysands well illustrates the liberties he constantly allowed himself in the analysis of his daughter and that of Ferenczi, whom he advised, on June, 1, 1916: “As you’ve wanted, if your fates allow, I’ll save two sessions for you every day. I hope to see you a lot otherwise, and would like you to dine with us at least once a day. Technical rules demand, however, that, outside of the sessions nothing personal be mentioned.”

In 1928, at the Hague Conference, Ferenczi, in his presentation on tact, mentioned that “Freud had said ‘negative’ and ‘positive’ things about ‘tact’; with the result that obedient subjects did not understand how elastic the conventions were, submitting to them as if they were written in stone.”

In fact, the technical rules that Freud initially wanted to make more flexible gradually became rigid; his early flexibility was shown by his remark recorded in the *Minutes* of February 8, 1910: “It is inconsistent

to say: I must not impart this or that. This simply cannot be said in such a general way. It is evident that the technique can be practiced with understanding and tact, or otherwise” (Nunberg and Federn, p. 417). Smiley Blanton, his patient, recalls that Freud said, in March 1930: “Now in the matter of papers on technique, I feel that they are entirely inadequate. I do not believe that one can give the methods of technique through papers. It must be done by personal teaching. Of course, beginners probably need something to start with. Otherwise they would have nothing to go on. But if they follow the directions conscientiously, they will soon find themselves in trouble. Then they must learn to develop their own technique” (p. 48).

All the same, freedom is not license, and Freud was clear about this in a letter to René Laforgue, dated July 2, 1928: “If you want to give the beginner the feeling of being a free man, of not being obliged to stick submissively to the rule, to trust his intuition and give free rein to his humanity, I fear that the results will be quite disappointing. His intuition will lead him, unflinching, in the wrong direction, and as far as his humanity is concerned, any position is closer to this than the analytic position” (1977h [1923–33]).

Since then, hundreds of articles and many books have been published on this subject; among them Edward Glover’s (1955) and Ralph Greenson’s (1967). The variety and the diversity of their positions show the need to distinguish, in psychoanalytic practice, between a simple “procedure,” whether on a trial basis or in an emergency, and a “method” that qualifies as properly psychoanalytic, within which such a procedure will find a place, or not (Mijolla). Processes recognized as effective, along with the theoretical goals that structured them when they were initiated, as well as the definitions of the goals and means of psychoanalysis, all changed as Freud continued to discover things, and were subject to further modification after his death. There is no “method,” except one based on a theory of analysis. Method and theory enrich each other in a permanent process of evolution, one that absorbs the lessons of experiments with sometimes ephemeral procedures, together with particular attention to their favorable or unfavorable consequences.

ALAIN DE MIJOLLA

See also: Action-language; Analyzability; Analysand; Fourth analysis; “Analysis Terminable and Interminable”;

Analytic psychodrama; Anticipatory ideas; Attention; Balint, Michael (Bálint [Bergsmann], Mihály); Bion, Wilfred Ruprecht; *Character Analysis*; Construction/reconstruction; “Constructions in Analysis”; Cryptomnesia; Evenly-suspended attention; Face-to-face situation; *Five Lectures on Psycho-Analysis*; Free association; Fundamental rule; Glover, Edward; Interpretation; “Lines of Advance in Psycho-Analytic Therapy”; Money in the psychoanalytic treatment; Narcissistic injury; Neutrality/benevolent neutrality; Psychoanalyst; Psychotherapy; Racker, Heinrich; “Recommendations to Physicians Practicing Psychoanalysis”; Reich, Wilhelm; “Remembering, Repeating and Working-Through”; Supervised analysis (control case); Termination of treatment; Therapeutic alliance; Tomasi di Palma di Lampedusa-Wolff Somersee, Alessandra; Training analysis; Training of the psychoanalyst; “Wild’ Psycho-Analysis”; Word association.

### Bibliography

- Blanton, Smiley. (1971). *Diary of my analysis with Freud*. New York: Hawthorn.
- Ferenczi, Sándor. (1955). The elasticity of psycho-analytic technique. In *Final contributions to the problems and methods of psycho-analysis*. London: Hogarth and the Institute of Psycho-Analysis. (Original work published 1928)
- Freud, Sigmund. (1898a). Sexuality in the aetiology of the neuroses. *SE*, 3: 259–285.
- . (1900a). The interpretation of dreams. Parts I and II. *SE*, 4–5.
- . (1904a [1903]). Freud’s psycho-analytic procedure. *SE*, 7: 247–254.
- . (1905a [1904]). On psychotherapy. *SE*, 7: 255–268.
- . (1909d). Notes upon a case of obsessional neurosis. *SE*, 10: 151–318.
- . (1912e). Recommendations to physicians practising psycho-analysis. *SE*, 12: 109–120.
- . (1919a [1918]). Lines of advance in psycho-analytic therapy. *SE*, 17: 157–168.
- Freud, Sigmund, and Laforgue, René. (1977h [1923–33]). Correspondance Freud-Laforgue, préface d’André Bourguignon. *Nouvelle Revue de psychanalyse*, 15, 235–314.
- Glover, Edward. (1955). *The technique of psycho-analysis*. London: Bailliere, Tindall & Cox.
- Greenson, Ralph. (1967). *The technique and practice of psychoanalysis*. New York: International Universities Press.
- Mijolla, Alain de. (1987). Unconscious identification fantasies and family prehistory. *International Journal of Psychoanalysis*, 68, 397–403.

Nunberg, Hermann, and Federn, Ernst. (1962–1975). *Minutes of the Vienna Psych. Society* (Vol. 1: 1906–1908). New York: International Universities Press.

## TECHNIQUE WITH CHILDREN, PSYCHOANALYTIC

The psychoanalysis of children represents an area of research and practice whose definition and progressive formation, through the twentieth century, were not established without clashes, conflict, and polemics. There have been successive waves of interest, with competing views, sometimes resulting in fixed oppositional positions, depending on the period.

The psychoanalysis of children is perceived by some as heretical, difficult to practice, even fundamentally utopian or impossible; by others, it is seen as an informative and reflexive paradigm, capable of enriching the theory and the technique of adult psychoanalysis. On one hand, it has been presented as intrinsically impure, on the other, much more rarely, it has seemed to be a kind of unrealizable ideal, fecund but somewhat vague.

These debates relate of course to the status accorded the mind of the child viewed on its own terms, and not only insofar as it is evolving into the mind of an adult, but also involve inevitable modifications in technique, since it is obvious that the framework defined by Sigmund Freud for the adult (with the couch, the basic rule of free association, absolute priority accorded to language and so forth) cannot be applied as such to children, especially to very young ones.

In this connection, two remarks should be made: first of all, one must be very careful to distinguish the psychoanalysis of the child from various applications of psychoanalysis to the domain of childhood (psychoanalytically inspired psychotherapies, combined parent-child therapies, analytic observation of newborns, so-called psychoanalytic family therapies, psychodrama, group therapies—with analytical overtones—or even the application of psychoanalytic concepts in education, pedagogy, and social fields). Of concern here will be only the psychoanalysis of the child, in its strictest sense, and not any of its looser applications.

Furthermore, any science—and psychoanalysis has a legitimate claim to this status, scientific pretensions, even if that is not its only possible definition—defines

itself at once by the presence of a framework, and also by its epistemological field. For psychoanalysis, there is a strict framework, and not only the formal appearance of one. In other words, as important as it is, merely having a framework is not enough to entitle something to be named a science; and the definition of psychoanalysis cannot be reduced to this feature. The essence of psychoanalysis is centered, at the minimum, on the dynamics of transference and countertransference, on the concept of resistance and the function of interpretation, and it is reasonable to judge that there is no effective analysis possible, without real work on these different planes.

All the same it is quite possible to imagine that this work can be conducted in different settings and, notably, in settings adapted to the various ages of the children. The whole purpose of the psychoanalysis of children is to succeed in developing these different aspects; for so long as these are not addressed fully, the risk of conflict and misunderstanding between those who treat adults and those who treat children will remain, a risk that René Diatkine evidently was trying to parry when he said: “I am not a psychoanalyst of children, I am a psychoanalyst who treats children.”

Regarded historically, the evolution of ideas concerning the technique of analysis of children has been marked by a some significant turning-points, linked to the work of the pioneers in this domain. Concurrently with the recommendations of Freud, who, from 1905, advised psychoanalysts to observe the psychosexual development of their own children, in an attempt to verify the reconstructed findings of the first adult treatments (Freud following his own advice, Karl Abraham observing his daughter Hilda, and Melanie Klein her youngest son), Herminie von Hug-Hellmuth was doubtless the first to undertake an authentic analysis of a child, in Berlin, during the First World War, recognizing the existence of transference and already utilizing, although in an unsystematic manner, games and drawings. Next was Eugenia Sokolnicka, in Warsaw, in 1919. In 1921, Klein settled in Berlin to practice the psychoanalysis of children, and Didier Houzel and Gilles Catoire remarked that “what can be considered as the prehistory of the psychoanalysis of children ended at the beginning of the 1920’s” (1986).

Subsequently, one of the great debates in the history of psychoanalysis occurred between Anna Freud and Klein, precisely on technical aspects that were due to a basic theoretical-clinical divergence. Donald W.

Winnicott eventually assumed an intermediary position in this debate, fairly close to the positions of Klein, especially on the question of the place of games in technique, but reproaching her, nevertheless, for what he saw as her insufficient attention, to the child's environment and particularly to the role of the real mother.

In France, a number of names should be mentioned, dividing, during the second half of the twentieth century, along the line of scission between Lacanian psychoanalysts and the non-Lacanian: Serge Lebovici, René Diatkine, Michel Soulé, among the latter; Françoise Dolto, Jenny Aubry, Rosine and Robert Lefort, among the former. These differences concerned theoretical references that were also reflected on the level of technique (the importance accorded to the child's wishes, and to the place of language, in particular). In the early twenty-first century the influence of the post-Kleinian movement is dominant in many countries in the conception and technical choices of child psychoanalysis (importance of counter-transference, exploration of archaic or primal levels of mental functioning, work on psychic boundaries, and so forth).

In 1926, in four lectures she gave at the Psychoanalytic Institute of Vienna, Anna Freud described an intermediary technique between the analytical and educational approaches. The limits she placed on the analysis of children were calculated on the basis of the following arguments: no transference neurosis is possible with the child (too great dependence on real parents); modification of the framework is required, having nothing in common with the free association technique of adults (absence of symbolic associations with games and drawings); there is need for a so-called preparatory phase during which the analyst "induces" the child by way of a certain charm to become involved in the treatment, by establishing a positive transference with the child, an educative role that is necessary if the analyst is to avoid the consequence of the lifting of repression and liberation of the drives.

In 1927, at a colloquium of the British Society, Klein refuted the propositions of Anna Freud, point by point. For her, analysis was incompatible with any educative attitude; the preparatory phase was in no way justified, because it was the interpretation of the anxieties in the transference which allowed the child to enter into the analytical process, the child being quite capable of developing an authentic transference neurosis.

Progressively, Anna Freud drew closer to the Kleinian positions, but for a long time there remained serious differences between the two schools as a legacy of this early opposition. It wasn't until 1990 that the first joint colloquium took place, between the Anna-Freudian Hampstead Clinic and the Kleinian Tavistock Clinic (this colloquium was to have been presided over by John Bowlby, who, in fact, died a few months before the event). These two institutions have remained, through 2005, very important centers for reflection on the subject of child psychoanalysis, certain names deserving mention, among many others: Anne-Marie and Joseph Sandler, Peter Fonagy, Hansi Kennedy, George Morane, of the Hampstead Clinic; Hanna Segal, Esther Bick, Martha Harris, Donald Meltzer, and Juliet Hopkins, of the Tavistock Clinic.

Given that there is no such thing as a purely technical problem, but that technical problems always refer to underlying theoretical-clinical issues (hence, the historical survey, above), it can be said that the question of psychoanalytic technique with children is based on four main elements: the place of parents in the process, the framework, the transference-counter-transference dynamic, and the function of interpretation.

Working with parents should be distinguished from the treatment, properly speaking, but it conditions it, in great part. Depending on the age of the child and the technique of each practitioner, positions vary as to the analyst's role in the family. In most cases, the work is effectuated by a consultant, not by the child's analyst, so that the child's "mental space" is better respected, but some technical variations are possible in this respect.

As far as the framework is concerned, a point in common with adult analysis concerns the number of sessions per week, which should be enough for a veritable analytical process to be begun (all the more so with psychotic, as opposed to neurotic children). Three visits a week seems to be the generally accepted frequency, alas not very often realized in practice. The question of payment has been also the source of much reflection, the notion of "symbolic payment" having been particularly developed by Françoise Dolto, in France, and by other authors influenced by her.

In addition, the place of the body and of preverbal communication, have attracted much attention, and have caused some changes in the way children are

treated, compared to adults. In the early twenty-first century, means such as games, drawings, or modeling clay are in very wide use, and usually considered as analogous to the adult's words, and as a basis for the practice of free association.

The counter-transference and corporal involvement of the child analyst is often more intense than that of the analyst of adults, which is why, unfortunately, analysts rarely continue until an advanced age to treat children, as Donald W. Winnicott was able to do. The difficulty of the task should not, however, be reduced to rationalizations as to its basic impossibility. The child, just like the adult, is living in "deferred action" from the very beginning, even if current developments in psychoanalysis of the very young might cause some modifications in the Freudian theory of deferred action; for example, by diffraction over a number of generations.

The major difficulty connected to the framework of analysis of children has to do with the role of the analyst himself, who has to find a balance between the freedom children are given to express themselves and the limits one must at the same time impose on them to avoid colliding with infantile omnipotence.

As to transference, particular attention deserves to be paid to the therapeutic alliance, already mentioned, which lies at the very heart of the controversy between Anna Freud and Klein. This is a particularly difficult notion when it comes to children: some authors see it as a precondition for the later development of the transference dynamic; others as a preliminary but conscious and ego-like version of the transference, properly speaking. It is clear, in any case, that with the child, in most cases, the therapeutic alliance depends in large measure on what kind of bond has or has not been established with the parents.

Interpretations can be metonymical, metaphorical, historical, or flatly transference, as with adults, but should have, over time, a containing effect, which gives them their therapeutic value, and this because the children treated are, mostly, those whose capacity for containing is defective, and whose psychic boundaries are still in the process of being formed. The kernel of this problem is knowing how to create for such children, while their internal framework is still in formation, an external structuring framework, one specifically derived and internalized from the framework of the treatment. The analysis of children's resistance has proven to be wholly indissociable from the analysis of the fantasy-contents and of the transference.

As with adults, many positions, often quite opposed to each other, have been taken regarding the conclusion of the child's analysis, it being understood that ideally the child should be the one to decide, even beyond the eventual disappearance of the symptoms that motivated the analysis—which would make sense, obviously, only in relation to the existence of suffering and intrapsychic conflicts obstructing the development of the child.

Following authors such as Hanna Segal and Donald Meltzer, the post-Kleinian movement has contributed much to the discussion of the technique of analyzing children. Meltzer (1967) even suggested describing the therapeutic process in five successive phases: gathering the elements of transference, sorting through confusions of place, sorting through confusions of bodily zones and modalities, [passing] the threshold of the depressive position, and, finally, the process of separation. Such a description, of course, risks being overly schematic, but it has had the virtue of being able to account for the dynamic of the process, as well as to allow the articulation of a certain number of technical approaches.

At the end of this introduction, it is fitting to recall, with Antonino Ferro (1997), that psychoanalysis is basically a single entity; and that there is really nothing to be gained by dividing the psychoanalysis of the child from that of the adult. Each is in a position to enrich the other, notably by way of a calm, comparative meditation on the various technical problems that are posed in the two fields.

BERNARD GOLSE

*See also:* Child analysis; Children's play; Controversial discussions; *Flower Doll: Essays in Child Psychotherapy*; *Psychoanalytical Treatment of Children*; Richard, case of; Squiggle; Transference in children; Transitional phenomena.

### **Bibliography**

- Freud, Anna. (1946). *The psychoanalytical treatment of children. Technical lectures and essays*. London: Imago.
- Houzel, Didier, and Catoire, Gilles. (1986). La psychanalyse des enfants. *Encyclopédie médico-chirurgicale. Psychiatrie*. Paris: E.M.-C.
- King, Pearl H. M., and Steiner, Riccardo. (1991). *The Freud-Klein controversies, 1941–45*. London and New York: Tavistock-Routledge.



Meltzer, Donald. (1967). *The psychoanalytic process*. London: Heinemann Medical.

Sandler, Joseph, Kennedy, Hansi, and Tyson. Robert L. (1980). *The technique of child analysis. Discussions with Anna Freud*. London: Hogarth and the Institute of Psychoanalysis.

## TEGEL (SCHLOSS TEGEL)

The Schloss Tegel was the first establishment in the world to provide psychoanalytic treatment in an institutional framework. It was inaugurated on April 10, 1927 at Berlin-Tegel by neurologist Ernst Simmel, who directed it until its economic collapse in August 1931.

Convinced by his experience treating war neuroses acquired in the course of World War I, Simmel first sought the financial support of the state for his project to open a clinic. Having failed to obtain this support in spite of his efforts and pleading, he founded, with the help of three administrators (Dr. Nussbrecher, director of the Phönix insurance company; Dr. Ludwig Jekels; and Prof. Julius Hirsch, state minister) a SARL (private limited company), the Sanatorium Schloss Tegel, as a psychoanalytic clinic. On November 6, 1926 a lease was signed with the owner of the castle, state councilor Reinhold von Heinz, concerning a “treatment center with accommodation for physicians, a pleasure garden and a park . . . for use as a sanatorium, authorizing the reception and treatment of patients suffering from various illnesses with the exception of physical deformities, sexually transmissible diseases, and mental patients.” (Schultz-Venrath, 1995).

Unfortunately, the clinic was never free of financial difficulties and had to be permanently supported by Sigmund Freud, who instituted a help fund for it, to which Marie Bonaparte, Dorothy Burlingham, René Spitz, Franz Alexander, Max Eitingon, Raymond de Saussure, and Hugo Staub contributed. In spite of this the closure of the clinic in August 1931 became inevitable in the economic crisis of the declining Weimar Republic, because patients could no longer afford to pay the hospitalization costs.

The clientele that Ernst Simmel treated in his seventy-four-bed clinic consisted of seriously ill neurotics; addicts of various kinds, including inveterate gamblers; children and adolescents presenting deficits in character development (kleptomania, for example); patients in acute life crises; and chronic patients with complications. The Schloss Tegel Sanatorium was destined to become a center for systematic psychotherapy

for patients suffering from organic illnesses. Among the collaborators having received analytic training we find Rudolf Bilz, Ludwig Fries, Alfred Gross, Irene Haenel-Guttman, Karl Maria Herold, Hellmuth Kaiser, Eva-Maria Rosenfeld, Francis Deri, Ilja Schalit, Edith Weigert-Vowinkel and Moshe Wulff.

In order to deal with multiple transference situations in a therapeutic fashion, the nursing personnel, who had received analytic training, had to function as an extension of the psychoanalysts. Simmel was the first to introduce the concept of psychoanalytic treatment for patients suffering from organic illnesses, a concept with a dyadic orientation. There were as yet no examples of group psychoanalysis. The therapeutic technique stressed the importance of avoiding regression by, on the one hand, taking social reality into account and, on the other, by offering timely analytic interpretations.

Three case histories were published from this clinic, two of them being posthumous: the spectacular treatment of a case of heart failure with pulmonary edema (Simmel, 1931b), a feminine perversion (Simmel, 1990) and a young pyromaniac (Simmel, 1949). With the exception of two patients who were paid for by a charitable organization, all the others were private patients.

LUDGER M. HERMANN AND ULRICH SCHULTZ-VENRATH

*See also:* Freud, Ernst; Germany; Simmel, Ernst; *Thomas Woodrow Wilson, Twenty-eighth President of the United States. A Psychological Study.*

### Bibliography

Simmel, Ernst. (1931b). Über die Psychogenese von Organstörungen und ihre psychoanalytische Behandlung. In E. Kretschmer and W. Cimbald (Eds.), *Bericht über den VI. Allgemeinen ärztlichen Kongress für Psychotherapie in Dresden, 14–17 Mai 1931* (pp. 56–65). Leipzig: Hirzel.

———. (1949). Incendiarism. In K. R. Eissler (Ed.), *Searchlights on Delinquency. New Psychoanalytic Studies Dedicated to Prof. Aichhorn on the Occasion of His 70th Birthday July 1948*. New York: International Universities Press, 90–101.

———. (1990). Neurotische Kriminalität und Lustmord. Eingeleitet und kommentiert von Schultz U., Hermanns L.M., Kütemeyer M.: die psychoanalytische Behandlung einer Lustmörderin im Jahre 1930. *Psyche*, 44, 71–99.

Schultz-Venrath, Ulrich. (1995). *Ernst Simmels psychoanalytische Klinik Sanatorium Schloss Tegel GmbH (1927–1931)*. Frankfurt am Main-Washington: Deutsche Hochschulchriften 2081, Mikroedition.

---

## TELEPATHY

“The process of telepathy is said to occur when a psychic act by one person results in the same psychic act in another person” (1933a [1932]). Sigmund Freud developed several hypotheses about the direct transmission of thought, or telepathy, seeing it as an archaic mode of communication between individuals and possibly a physical process that had become mental at the two ends of the communications sequence.

Carl Jung and, later, Sándor Ferenczi, were, along with Freud, interested in the question of telepathy. Freud’s attitude toward it was simultaneously one of openness, because of its proximity to the unconscious, and reserve, fearing that psychoanalysis might find itself compared to occultism. His interest was essentially personal and longstanding, since he believed that he was able to communicate remotely with his fiancée Martha by thought alone when he was in Paris (Jones, 1957, vol. 3). Later, he attempted to conduct experiments of this kind, which is reflected in his correspondence with Ferenczi in 1910 and with his daughter Anna in 1925. But Freud maintained that the notion of telepathy was outside psychoanalysis, which was only interested in using a scientific, not a mystical, approach in the investigation of psychic activity. In fact, in discussing the telepathy performed by mediums, he recommended that we investigate their psychology, as well as that of their customers. Nonetheless, he felt that the phenomenon in question, namely the transmission of thought, was at least probable even if it was not demonstrable.

Freud advised Jung, and especially Ferenczi, to be cautious about revealing their attitudes about telepathy, which might have risked jeopardizing the status of psychoanalysis. He expressed this sentiment publicly on several occasions, the first time in 1921, in a short text entitled “Psychoanalysis and Telepathy,” which was read during a scientific meeting with his followers (1941d [1921]), the second time in an essay, “Dreams and Telepathy” (1922a), and then in 1925 in a note on “The Occult Meaning of Dreams” (1925i), published in the *New Introductory Lectures on Psychoanalysis* (1933a).

In fact Freud couched his own interest in the occult, in the form of a critique of a skeptical and limited rationalism, in rather sharp terms: “Not for the first time would [psychoanalysis] be offering its help to the obscure but indestructible surmises of the common people against the obscurantism of educated opinion”

(1941d [1921], p. 178). However, this interest did not lead him to accept telepathy as such, but to examine with greater attention the examples of premonitions or of premonitory dreams, which led him to question the after-the-fact reconstruction of narratives of partially falsified acts.

The value of Freud’s investigation, therefore, extends well beyond telepathy, touching upon the epistemological justification of the interpretative process used for dreams and analytic constructions. At the same time, as a question, telepathy is most certainly related to that of the unconscious through the hypothesis of telepathic communication in primitives and animals. Animism, the occult, and the uncanny, therefore, form a field that is neither inside nor outside psychoanalysis, but which psychoanalysis attempts to approach using its own methods.

SOPHIE DE MIJOLLA-MELLOR

*See also:* Latent; *New Introductory Lectures on Psychoanalysis*; Occultism; Omnipotence of thought; “Recommendations to Physicians Practicing Psychoanalysis”; “‘Uncanny’, The.”

### Bibliography

- Freud, Sigmund. (1922a). Dreams and telepathy. *SE*, 18: 195–220.
- . (1933a [1932]). New introductory lectures on psycho-analysis. *SE*, 22: 1–182.
- . (1941d [1921]). Psycho-analysis and telepathy. *SE*, 18: 173–193.
- Granoff, Wladimir, and Rey, Jean-Michel. (1983). *L’Occulte, objet de la pensée freudienne*. Paris: Presses Universitaires de France.
- Jones, Ernest. (1953–1957). *Sigmund Freud. Life and work*. London: Hogarth Press.

---

## TENDERNESS

The term *tenderness* is derived from the Latin *tener*, which expresses the idea of a young life filled with freshness. By extension it can apply to a person who is soft, easily wounded morally, and sensitive to altruistic feelings.

Freud distinguished between “the affectionate and the sensual current” (1912d, p. 180): the older of the

two is tenderness, which corresponds to the choice of the primary infantile object, which is based on the drive for self-preservation and directed toward those who care for the infant. “These affectionate fixations of the child persist through childhood, and continually carry along with them erotism, which is consequently diverted from its sexual aims” (p. 181). It is only at puberty that the “powerful sensual current that no longer fails to recognize its aims” (p. 181) is added. The objects of the primary infantile choice are then invested with powerful libidinal forces that conflict with the prohibition against incest. It is by displacement toward a new object with which sexual fulfillment is possible that the current of tenderness and the current of sensuality are reunited in the love relationship.

Tenderness emits from an aim-inhibited sex drive (libido). It is parental, and in particular maternal, tenderness that “rous[es] her child’s sexual instinct and prepar[es] for its later intensity” (1905d, p. 223). If it is excessive, it will lead to “a precocious sensuality that will spoil the child” and lead to a predisposition to neurosis.

Using this as his starting point, Sándor Ferenczi distinguished a tenderness stage, or passive object love stage, and a passion stage (1933). Michael Balint, his student and follower, developed the concept of archaic or primary object relation (*Primary Love and Psychoanalytic Technique*, 1952). The most precocious phase of psychic life “is not narcissistic in nature: it is directed toward objects, but this precocious object relationship is a passive relationship—I must be loved and satisfied without having anything to give in return.” “This form of object relation is not associated with any erogenous zone”; mother and child do not have separate identities, their reciprocal instinctual goals are interdependent. This results in active infantile behaviors where the impulse to cling plays a preponderant role.

Paul-Claude Racamier summarized these issues and developed them further. Primary love “is a relation that unites by separating: uniting to the extent that it differentiates and distinguishing to the extent that it reunites; this is the primal paradox of narcissistic seduction” (1995). Tenderness is used to convey this relation: “It is both a mode of cathexis and an affective tone.” It is not directly sexual but it is not without sensuality; well-being—a developed form of self-preservation—is sought instead of a push toward discharge. “Its special feature is to envelop; its specific site, the skin.” Maternal

gestures consist of gentle caresses, based on continuity and tact within a climate of “temperate warmth.”

During the 1950s, John Bowlby, relying on the direct observation of babies interacting with their mothers and on ethological data, hypothesized the existence of a primary and fundamental need for attachment. This was manifest very early in the newborn’s archaic behavior (crying, glances, holding) and became more diversified as the infant grew. This work had considerable impact and led to additional research in the field of precocious interaction. These authors identify the need for attachment as based on physical contact, primarily through the skin. In 1968 Esther Bick proposed the concept of a first psychic skin whose aim was to keep the parts of the personality together “as experienced by them passively.” In 1974 Didier Anzieu developed the concept of the “skin ego,” “an original parchment that preserved the marks of a ‘primal’ preverbal writing made of cutaneous traces,” which culminated in the idea of the psychic envelope. After birth the skin fulfills functions that were formerly provided in utero by the maternal envelope.

Julian de Ajuriaguerra studied the constitution of the clinging-hugging gesture in children. Initially it is an extension of the arm toward the selected person, then the closing of the arm in an embrace. This gesture, in its complexity, is only fully realized after the age of nine months. Prior to this, one can observe, early in the life of the child, the use of clinging (Moro) and gripping reflexes. Then, around the age of two to three months, the child attempts to open and extend its arms. At around six months, the baby can coordinate the gesture with speech intonation mimicry. At around nine months, an organized pattern of clinging is established, and will develop, around one year of age, into more elaborate forms of related behavior. Hugging, squeezing, caressing, kissing, and other gestures of skin-to-skin contact are the most frequent manifestations of tenderness in mother-child interactions. This “tonic dialogue” forms a secure foundation for emotional development.

RÉGINE PRAT

*See also:* Aggressiveness/aggression; Body image; “Confusion of Tongues between Adults and the Child”; Friendship; Latency period; Love; Maternal; Narcissism, primary.

## Bibliography

- Ajuriaguerra, Julian de, and Casati, Irène. (1985). Ontogénese des comportements de tendresse: I. Étude de l'embrassement-étreinte, à partir du pattern "tendre les bras." *Psychiatrie de l'enfant*, 28 (2), 325–402.
- Balint, Michael. (1952). Primary love, and psycho-analytic technique. London: Hogarth.
- Bowlby, John. (1969). *Attachment and loss* (Vol. I). London: Hogarth.
- Ferenczi, Sándor. (1949). Confusion of tongues between adults and the child. The language of tenderness and of passion. *International Journal of Psycho-Analysis*, 30, 225–230. (Original work published 1933 [1932])
- Freud, Sigmund. (1905d). Three essays on the theory of sexuality. *SE*, 7: 123–243.
- . (1912d). On the universal tendency to debasement in the sphere of love. *SE*, 11: 177–190.
- Racamier, Paul-Claude. (1995). *L'Inceste et l'Incestuel*. Paris: Éditions du Collège de psychanalyse groupale et familiale.

## TERMINATION OF TREATMENT

Very early on Sigmund Freud determined what for him was the sign of the end of a psychoanalytic treatment, that is to say that it is complete with the “practical recovery of the patient, the restoration of his ability to lead an active life and of his capacity for enjoyment” (1904a, p. 253), criteria that he repeated in the Lecture 28 of the *Introduction to Psychoanalysis* (1916–17a). But almost as soon, noticing the unpredictability of the resolution of the transference, he remarked: “In the early years of my psycho-analytic practice I used to have the greatest difficulty in prevailing on my patients to continue their analysis. This difficulty has long since been shifted, and I now have to take the greatest pains to induce them to give it up (1913c, p. 130).

In “Analysis Terminable and Interminable” (1937c) he specified the ideal conditions for termination of treatment: “An analysis is ended when the analyst and the patient cease to meet each other for the analytic session. This happens when two conditions have been approximately fulfilled: first, that the patient shall no longer be suffering from his symptoms and shall have overcome his anxieties and his inhibitions; and secondly, that the analyst shall judge that so much repressed material has been made conscious, so much that was unintelligible has been explained, and so

much internal resistance conquered, that there is no need to fear a repetition of the pathological processes concerned” (1937c, p. 219).

Eight years earlier Sándor Ferenczi suggested: “The proper ending of an analysis is when neither the physician nor the patient puts an end to it, but when it dies of exhaustion, so to speak, though even when this occurs the physician must be the more suspicious of the two and must think of the possibility that behind the patient’s wish to take his departure some neurotic factor may still be concealed. A truly cured patient frees himself from analysis slowly but surely; so long as he wishes to come to analysis, he should continue to do so” (“Termination of Analysis,” p. 85). He also indicated the “ideal goal” to aim for: “The far sharper severance between the world of fantasy and that of reality which is the result of analysis gives them an almost unlimited inner freedom and simultaneously a much surer grip in acting and making decisions; in other words it gives them more economic and more effective control” (p. 81).

Extending the duration of treatment and the perennial problem of the “interminable analysis” have always been issues of concern to the psychoanalytical community and have been ceaselessly discussed in many articles, congresses, and seminars. Multiple and disparate criteria to judge when a treatment may be considered ended have consequently been proposed, in accordance with changing theory and practice.

On the analysand’s side the following has been recommended: behavior adapted to reality, an ability to handle suffering and depression, overcoming of penis envy and castration anxiety, access to genitality in psychosexual behavior, reinforcement of sublimations, diminution of guilt, and the like. Sacha Nacht (1965) recommended taking account of the “lessening of the fear of suffering, the acceptance of the patient of himself, his ability to satisfy his desires, compatible at once with his ideals and his milieu, and the possibility of his engaging in action, while avoiding submission to the automatism of repetition” (Lebovici, 1980). Attachment to a new external libidinal object was regarded with suspicion by Wilhelm Reich (1949) and especially by Annie Reich, who saw therein a defensive *acting-out*, like the divorces that occur at the end of an analysis.

On the analyst’s side there is an “intuition” by unconscious perceptions that termination is necessary,

that the transference neurosis is on the way to being “liquidated.” Melitta Schmideberg (1938) has even recommended that the analysis be systematically interrupted after six years so that the bond with the analyst won’t make separation impossible.

With the “Wolf Man” case (1918b), Freud used the technique of fixing a date of termination to the analysis, but the results led him to rarely ever repeat this, nor to recommend it. Sándor Ferenczi, with the “active technique,” like Otto Rank, with the application to treatment of the principles of *The Birth Trauma* (1924), both aimed at shortening the duration of the treatment, but their attempts were criticized by most of their contemporaries and by Freud himself. Franz Alexander suggested experimental interruptions (1963), while, in France, Sacha Nacht (1965) recommended breaking “the closed world” of the transference by making the analyst more “present,” to “demythify” him, so as to favor “integration, by successive, nuanced phases into external, objective reality”—suggestions that have since been severely criticized. A process based on progressive severance, consisting in diminishing gradually the frequency of sessions is doubtless the easiest and the most often employed.

Whatever the criteria utilized to recognize that an analysis is in process of termination, they can only be based on the evolving conception that the protagonists of the situation have been maintaining of the goals of the treatment, as their special relation proceeds, and as they analyze the conscious and unconscious motivations inciting them to conclude it. Freud’s realist positions on the two “rocks,” which any psychoanalytic pretension to omnipotence will come up against, should not be forgotten either: the male “refusal of femininity” and the “penis envy” of the female. The end of the analysis is also a recognition of the unanalyzable, even if every treatment should involve an attempt to gain on a little bit of its territory.

Generally there has been agreement that the traditional framework of the treatment should be maintained until the very last session, while a few face-to-face sessions have been recommended in some cases where working through the separation was particularly difficult.

ALAIN DE MIJOLLA

See also: Psychoanalytic treatment.

## Bibliography

- Ferenczi, Sándor. (1955). The problem of the termination of the analysis. In *The selected papers of Sándor Ferenczi*. Vol. III (*Final contributions to the problems and methods of psychoanalysis*). (Michael Balint, Ed.; Eric Mosbacher, et al, Trans.). New York: Basic Books. (Original work published 1927)
- Firestein, Stephen K. (1974). Terminasion de l’analyse. *Revue française de psychanalyse*, 44, 2.
- Freud, Sigmund. (1937c). Analysis terminable and interminable. *SE*, 23: 209–253.
- Lebovici, Serge. (1980). L’expérience du psychanalyste chez l’enfant et chez l’adulte devant le modèle de la névrose infantile et de la névrose de transfert (The experience of the psychoanalyst of children and adults with the models of infantile neurosis and transference neurosis). *Revue française de psychanalyse*, 44, 5–6.
- Nacht, Sacha. (1965). Le transfert (Transference). In *Guérir avec Freud*. Paris: Payot, 1971.

---

## THALASSA. A THEORY OF GENITALITY

Freud described Ferenczi’s *Thalassa. A Theory of Genitality* as “the boldest application of psycho-analysis that was ever attempted” (1933a, p. 228). It is worth noting that the Hungarian edition of the work (Budapest, 1929) bore a different title: “Catastrophes in the Development of the Genital Function: A Psychoanalytic Study.”

Ferenczi takes as his first axis of reference the parallelism between catastrophic moments in the development of the embryo (or ontogenesis) on the one hand, and in the evolution of the species (or phylogenesis) on the other. Proposing a vast fresco, summarized in a synoptic table of presumed parallels (p. 69) and based on Lamarck’s evolutionary theories and on Haeckel’s fundamental rule of recapitulation, which it rounds out, he brings together two seemingly distinct temporal perspectives: the time of the germ cell, when the human was a mere monoblast destined by fertilization to become an egg, then an embryo, and after birth to continue living in an extended dependency on the environment; and the time that begins with the emergence of organic life on earth, and which can be described by reference to the various ice ages of the Quaternary era. How many tens of thousands of years were thus recapitulated in the transformation of the

ovum into the newborn? As Nicolas Abraham (1962) notes, this “cosmogonic epic seeks its meaning in the automatism of repetition itself.”

The second yardstick introduced by Ferenczi in his interpretation of the erotic meaning of reality, of coitus, of sleep, or of sexual impotence is regression. For the adult man, coitus embodies a striving on the part of the ego toward a threefold identification: a symbolic identification of the whole organism with the phallic function; a hallucinatory (or specular) identification with the feminine partner; and a real identification, effected as “the genital secretion [does] in very truth penetrate into the uterus” (p. 74), as the biology of pleasure makes the regeneration of the human being into a material reality. Ferenczi ascribes a traumatolytic function to the orgasm. To buttress these analogies, he takes as a model the fusion of sexual cells familiar to embryology, extrapolating the notion of “amphimixis” to account for the partial erotisms of different organs. By analogy with disturbances of language, he describes erectile dysfunction as “a kind of genital stuttering” (p. 9). He dubs his working method “utraquism,” meaning that a single phenomenon may be viewed in two complementary perspectives, so that technique and theory have a recursive relationship.

The ramifications of this text of Ferenczi’s were considerable. In *Totem and Taboo* (1912–13a), Freud had constructed a myth of the origin of civilization on the basis of an animal, human, and/or divine parricide, reparation for which was due “out of love for the father” and not just “in the name of the father” (fraternal alliances, codification of the prohibition against incest); in *Thalassa*, Ferenczi evokes a carnival of bodily organs whose regressions serve to actualize symbolic remnants (marriage bonds, the search for the child within the adult after post-traumatic fragmentation, and so on). With respect to later psychoanalysts, it is clear that *Thalassa* is an anticipation of Jacques Lacan’s thinking on the logic of the unconscious and of his topography of the Imaginary, the Symbolic, and the Real. The work also foreshadows future psychosomatic studies (which Ferenczi calls *bioanalysis*). It is worth noting that such authors as Pierre Teilhard de Chardin, André Leroi-Gourhan, Konrad Lorenz, Yves Coppens, and René Thom have arrived in this connection at equally original hypotheses.

PIERRE SABOURIN

See also: Amphimixia/amphimixis; Archaic mother; Ferenczi, Sándor; Psychic causality.

#### Source Citation

Ferenczi, Sándor. (1924). *Thalassa. Versuch einer Genitaltheorie*. Leipzig and Vienna: Internationaler Psychoanalytischer Verlag. *Thalassa: A Theory of Genitality* (Henry Alden Bunker, Trans.). Albany, NY: Psychoanalytic Quarterly, 1938.

#### Bibliography

- Abraham, Nicolas. (1962). Preface to Sándor Ferenczi, *Thalassa. Psychanalyse des origines de la vie sexuelle*. (Translated into French by J. Dupont and S. Samama). Paris: Payot.
- Freud, Sigmund. (1912–13a). Totem and Taboo. *SE*, 13: 1–161.
- . (1933c). Sándor Ferenczi. *SE*, 22: 225–229.
- Pragier, Georges. (1955). Un Inédit de Ferenczi. In *Sándor Ferenczi. Monographies of the Revue Française de Psychanalyse*. Paris: PUF.
- Sabourin, Pierre. (1985). *Ferenczi. Paladin et grand vizir secret*. Paris: Éditions Universitaires.

---

### “THEME OF THE THREE CASSETS, THE”

In “The Theme of the Three Caskets,” Sigmund Freud presents a wealth of extremely complex thoughts in just a few short pages. At the beginning are two scenes from Shakespeare, in which the number three plays an essential role: First, the choice of *three* pretenders to Portia’s hand between *three* metal caskets in *The Merchant of Venice*; and second, in *King Lear* the dying King’s partition of his kingdom between his *three* daughters, according to the love they show for him. In both these two plots, the humblest thing is shown to be the most precious: plain lead on one side, the mute love of Cordelia on the other. Although Freud initially draws on Shakespeare as his source for the choice between caskets; he ends up relying on myths that deal with the choice a woman must make between three pretenders, but which is inverted (as in the case of the choice between the three caskets and in the logic of the dream) into the choice a man makes between three caskets, that is, three women.

This leads Freud to evoke other scenes that turn on the number three in myths, folklore and literature, for instance constellations of three sisters where the choice always fall upon the third one who is the most unique. Freud identifies this uniqueness of the third as her

“muteness,” and then recalls how muteness in psychic life is typically a representation of death. The third daughter, seen from this perspective, may be viewed as Death, the Goddess of Death. The sisters appear, consequently, as the three daughters of Fate—according to mythological tradition, the three Moirai, Parcae, or Norns. Freud’s detour through mythology makes the goddesses of fate represent the inexorable Law of Nature, and thus of the passing of time and the ineluctability of death as well.

Returning to the choice between three sisters, Freud seeks to soften any resultant contradictions between this detour through mythology and the specific choice itself by reminding us that fantasy activity typically inverts what is disagreeable into its contrary. Fatality, the inexorability of death, is transformed into a free choice. In *King Lear* the old man appears at the end carrying the dead Cordelia in his arms. Freud refers the powerful effect this produces to the latent message transpiring behind the manifest representation of the scene: in fact it is Cordelia, Goddess of Death, who carries the dead king off the battlefield.

Although a minor work, this magisterial essay demonstrates concretely, even in its use of free association, the fecundity of the analytical method when applied to literature, myths, and folklore; while at the same time illustrating the laws of psychical functioning, such as the inversion of a wish into its opposite.

In a letter to Sándor Ferenczi dated July 9, 1913, Freud revealed that the “subjective condition” he was in when writing this essay was occasioned by the fact that his third child, Anna, was beginning to occupy a very unique place in his life.

ILSE GRUBRICH-SIMITIS

*See also:* Literature and psychoanalysis; Mother goddess; Silence.

### Source Citation

Freud, Sigmund. (1913f). Das Motiv der Kästchenwahl. *Imago* 2, 257–266; *GW*, 10, 24–37; The theme of the three caskets. *SE*, 12: 291–301.

### Bibliography

Freud, Sigmund, and Ferenczi, Sándor (1992–2000). The correspondence of Sigmund Freud and Sándor Ferenczi. (Eva Brabant, Ernst Falzeder, and Patrizia Giampieri-Deutsch,

Eds.; Peter T. Hoffer, Trans.); Cambridge, MA: Belknap Press of Harvard University Press.

## THERAPEUTIC ALLIANCE

*Therapeutic alliance* refers to the mutual collaboration established between a psychoanalyst and a patient to overcome the neurotic or psychotic resistance that blocks change and the healing process. Freud provided a clear description of this in his *Outline of Psychoanalysis*, “The analytic physician and the patient’s weakened ego, basing themselves on the real external world, have to band themselves together into a party against the enemies, the instinctual demands of the id and the conscientious demands of the super-ego. We form a pact with each other. The sick ego promises us the most complete candor—promises, that is, to put at our disposal all the material which its self-perception yields it; we assure the patient of the strictest discretion and place at his service our experience in interpreting material that has been influenced by the unconscious. Our knowledge is to make up for his ignorance and to give his ego back its mastery over lost provinces of his mental life. This pact constitutes the analytic situation” (1940a [1938]).

Following his theorization of “resistance,” Freud abandoned contemporary psychotherapeutic thinking to begin developing “psychoanalysis.” The discovery that his patients unconsciously refused to provide themselves with the means for improvement, no matter how much they asked for it, was to lead him to his description of the “secondary benefit” of the illness and his understanding of the need to support the work of therapy through positive transference in order to overcome the unconscious obstacles represented by negative transference or the resistance to change.

“Healing is achieved through love,” he wrote on December 6, 1906, in a letter to Carl Gustav Jung. This belief was often repeated and led Freud, during his therapeutic work—as exemplified in his work with the “Rat Man” (1909d)—to encourage, through words or signs, the confidence of his patients and their attachment to him.

On several occasions Freud mentioned this “analytic pact” concluded between the conscious ego of the patient and the therapist. Freud did not fail to point out the constant shortcomings, the most important of

which has to do with the transference neurosis, which, if it is not recognized and analyzed, risks blocking the patient's associative process. The patient then "behaves as if he were not in treatment, as if he had not concluded a pact with the doctor." (1916–17a)

Subsequently, a number of analysts have described the modalities of an alliance that is essential to overcoming the inherent difficulties associated with therapy. Richard Sterba, in 1934, described the split in the ego that would allow the analyst to appeal to his patient's powers of reasoning to fight against his impulses and repression. But it was Edward Bibring who first referred to the "therapeutic alliance" (1937) between the analyst and the "healthy" part of the patient's ego. In this he was faithful to Freud, who wrote that same year in *Analysis Terminable and Interminable*: "The analytic situation consists, as we know, in our alliance with the ego of the person-object to conquer the unconquered parts of his id and therefore to integrate them in the synthesis of the ego. The fact that such a collaboration often fails in the psychotic provides, in our judgment, an initial point of support. The ego with which we are able to conclude such a pact must be a normal ego" (1937c).

After the Second World War the concept of a therapeutic alliance enjoyed considerable success in the United States when Elisabeth Zetzel, in 1956, made it a component of psychoanalytic technique, especially during the initial stages of therapy. She compared the therapist's attitude to the mother's intuition toward her infant and made this alliance the condition for the emergence and resolution of the transference neurosis (1965).

This approach, felt to be too thoroughly infiltrated with Kleinian thought, was criticized by Ralph Greenson, who, the same year, proposed the notion of a *working alliance*. The term was used for subjects capable of object relations (thereby excluding overly narcissistic personalities) and is described as "a relatively rational, desexualized transference phenomenon," capable of controlling aggressive impulses (1965). But Greenson also insisted on the fact that this working alliance, based on the "mature and rational" ego, was established outside the analysis of transference and necessitated actions or comments by the psychoanalyst on the reality of the relationship (for example, recognizing that the patient's criticism is justified rather than interpreting the need to criticize the analyst). Several authors judged Greenson's concept to be outside

the framework of analytic neutrality and abstinence (Jacob A. Arlow and Charles Brenner, 1964; Mark Kanzer, 1975, for example).

The question arises of the limits of action for the psychoanalyst, a question presented in terms of the weight of his reality in the therapeutic relationship. Just how far can the maintenance of positive transference, or the appeal to the rational by a split part of the ego—which in its theorization is very similar to the concept of the "conflict free ego" integral to ego psychology—get, before outside factors present the emergence of, or submerge, the psychic reality that the psychoanalytic situation is in fact supposed to promote? It was Joseph Sandler (1973) who insisted on this distinction when he emphasized the necessity of a therapeutic alliance sustained by interpretation alone.

ALAIN DE MIJOLLA

*See also:* Greenson, Ralph; "Outline of Psychoanalysis, An"; Psychoanalytic treatment; Technique with adults, psychoanalytic; Transference in children; Transference relationship.

### Bibliography

- Bibring, Edward. (1937). Contribution to the symposium on the theory of the therapeutic results of psycho-analysis. *International Journal of Psycho-Analysis*, 18, 170–189.
- Greenson, Ralph R. (1965). The working alliance and the transference neurosis. *Psychoanalytic Quarterly*, 34, 155–181.
- Sandler, Joseph, Dare, Christopher, and Holder, Alex. (1973). *The Patient and the analyst: The basis of the psychoanalytic process*. New York: International Universities Press.
- Zetzel, Elisabeth R. (1956). Current concepts of transference. *International Journal of Psycho-Analysis*, 37, 369.
- . (1965). The theory of therapy in relation to a developmental model of the psychic apparatus. *International Journal of Psycho-Analysis*, 46, 39.

---

## THING-PRESENTATION

In many of Freud's writings, "thing-presentation" means solely what it means for empiricist psychology, as his concept of the mnemonic image or trace would suggest. In his paper "The Unconscious" (1915e), however, Freud defined "thing-presentation" as "the



cathexis, if not of the memory-images of the thing, at least of remoter memory-traces derived from these” (p. 201).

This definition refers to the theory that Freud had worked out on the contrast between perception and memory and on the sequence of mnemonic systems. The psychic apparatus, he had concluded, has a spatial structure in which presentations are related to one another as a function of different types of associations. This means that a thing-presentation is significant less by virtue of its individual character than by virtue of its being coded as a link in a network. Rather than being a direct duplication of an object, a thing-presentation is an inscription in the systems of the mind of certain aspects of the object relative to an instinctual cathexis.

In his monograph on aphasia (1891b) Freud first drew the distinction between the presentation of a thing (which at that time he called an “object-presentation”) and the presentation of a word. In this neurological work, he classified the different forms of aphasia on the basis of a psychology of mental representations independent of the nervous system, thus parting company with his predecessors, who had constructed associationist models based on the search for cerebral localization. Freud defined the link between a thing-presentation and a word-presentation as the result of an association (which in terms of the theory of signs might be called arbitrary) between a sound image specifically representing the word and the visual image that of all possible mnemonic images is especially representative of the thing.

There is an inescapable connection here with the signifier/signified relationship that Ferdinand de Saussure would later be the first to describe, for Freud explicitly asserted in his work on aphasia that “a word . . . acquires its *meaning* by being linked to an ‘object-presentation,’” and not by reference to the thing itself (*SE* 14, p. 213). By embracing this account of meaning, Freud preserved differences internal to language and differences external to it, for thing-presentations, on this view, still refer to things in the outside world.

The compounds “thing-presentation” and “word-presentation” thus acquired a double sense, depending on how the relationship between the two component terms was understood. On the one hand, one could take the thing or word concerned to be represented by the corresponding thing- or word-presentation, that is, by mental visual images and sound images that can

be assimilated to the linguistic concepts of the signified and the signifier respectively. On the other hand, one could understand thing-presentations and word-presentations as referential signs, in which case these terms would denote representatives of things and words in the outside world. As a mnemonic image, a presentation in a sense indicates the referential or denotative function, and thus restores the sign-thing relationship that the signifier/signified opposition, immanent to the sign, excluded.

More than twenty years later, Freud, in his article “The Unconscious” (1915e), called once more on the distinction between thing- and word-presentations, this time to help overcome the difficulties inherent in topographical and economic hypotheses advanced to explain the differences between actual experience and what was heard during analysis. His aim was to relate such differences, not to varied forms of aphasia, but rather to distinct mental systems: “The conscious presentation comprises the presentation of the thing plus the presentation of the word belonging to it, while the unconscious presentation is the presentation of the thing alone” (p. 201).

This hypothesis once again raised the vexing question of the relationship between thought and language. It promoted the idea that a thought precedes language: thought is initially unconscious and concerned with the sense impressions left by objects; when it later becomes conscious, it does so only by means of word-presentations. The question of thought thus led back to a realm prior to language, a realm that Freud occasionally compared to Kant’s noumenal realm, the realm of the thing-in-itself.

On this view, thing-presentations correspond less to images than to thoughts or ideas of things that have lost all the sensory vividness of perception. These thing-presentations are incorporated into an associative process along with other presentations, thus constituting a thought process that, by definition, is devoid of quality or feel. Hence there is an essential need for word-presentations, which re-endow thing-presentations with their former sensory vividness. Freud did not exclude the possibility of thing-presentations directly becoming conscious; dream images and hallucinations were evidence of such a process. But he stressed that nonverbal thought is a very imperfect means of bringing items into consciousness—witness how we picture topographical relationships in dreams (1923b, p. 21).

The specificity of the notion of thing-presentation in psychoanalysis lies in the difference between cathected external objects and internal objects resulting from the processes of introjection and projection directed at external objects. In the primitive splitting of ego and object that occurs when the object relationship is established, when the mother is first perceived as a whole object, it is possible to discern the origin of a topographical distinction between psychic systems, and thus the origin of the unconscious. This moment, which correlates with the defense mechanism of primal repression, is the starting point of representation.

ALAIN GIBEAULT

*See also:* Action-(re)presentation; Ego; Fantasy, formula of; Ideational representation; Infans; Multilingualism and psychoanalysis; Preconscious, the; “Unconscious, The”; Visual; Word-presentation.

### **Bibliography**

Freud, Sigmund. (1891b). *On aphasia: A critical study* (E. Stengel, Trans.). New York: International Universities Press, 1953. Extracts in Freud (1915e), SE 14.

———. (1915e). The unconscious. SE, 14: 159–204.

———. (1923b). The ego and the id. SE, 19: 1–66.

Gibeault, Alain. (1985). Travail de la pulsion et représentations: Représentation de chose et représentation de mot. *Revue française de psychanalyse*, 49 (3), 753–772.

### **Further Reading**

Tesone, J. E. (1996). Multi-lingualism, word, thing presentations and psychic reality. *International Journal of Psychoanalysis*, 77, 871–883.

---

## **THING, THE**

In the apparatus of the psyche, *the Thing* represents the secret center of human desire, the nucleus of pleasure/unpleasure. This nucleus is opposed to the reality principle, which it threatens to undermine. The Thing, also called the “lost object,” acts as the cause of desire and a sign of longing for an impossible reunion with the object.

Sigmund Freud first referred to the Thing in 1895, in “A Project for a Scientific Psychology” (1950a). He used the term again in 1925 in his essay “Negation.”

Jacques Lacan fully elaborated this Freudian notion in his seminar *The Ethics of Psychoanalysis* (1992).

An instance of the Thing develops from a complex set of cathected perceptions and memory images that have given pleasure in the past. This set includes a stable kernel, called the Thing, and a variable element, or predicate. The Thing arises in the primordial relation between the infant seeking fulfillment of its vital needs and the primary caregiver, the “fellow being,” who is also the first hostile object. The kernel or nucleus is inaccessible to judgment, while the predicate is the object of a judgment that must verify whether the memory image corresponds to reality. In Lacanian psychoanalysis, this process of judging forms the basis for the ego.

The Thing is situated in the unconscious articulation of desire. In its origin, it posits the Other as unconscious, as the force withholding the signifier of satisfaction, while reality is subverted by the symbolic function of memory traces of the lost object, from which the subject’s desire is alienated.

JEAN-PAUL HILTENBRAND

*See also:* “Negation”; Other, the; Subject’s desire; Unary trait.

### **Bibliography**

Freud, Sigmund. (1925h). Negation. SE, 19: 233–239.

———. (1950c [1895]). A project for a scientific psychology. SE, 1: 281–387.

Lacan, Jacques. (1992). *The seminar of Jacques Lacan. Book 7: The ethics of psychoanalysis, 1959–1960* (Dennis Porter, Trans.). New York: W. W. Norton.

---

## **THOMAS WOODROW WILSON, TWENTY-EIGHTH PRESIDENT OF THE UNITED STATES: A PSYCHOLOGICAL STUDY**

The Freud bibliography by Ingeborg Meyer-Palmedo and Gerhard Fichtner attributes to Freud the preface of *Thomas Woodrow Wilson, Twenty-Eighth President of the United States: A Psychological Study*—a hybrid work; it has remained one of the most ignored of all the works to which Freud has contributed. Peter Gay, who scrupulously reconstructed the genesis of the text (1988), noted, quoting William C. Bullitt, how

Freud's "eyes brightened" when, in May 1930, during a visit to the clinic at Schloss Tegel in Berlin, Bullitt spoke to him about a book he wanted to write on the Treaty of Versailles (p. v). Haunted by death and having just gone through another operation, Freud at once suggested that he contribute a study of President Wilson.

Although—or because—Wilson's personality and actions had been "from the beginning unsympathetic to me" (p. xi), Freud immediately began writing. His steps can be traced up to August 1931, when Ambassador Bullitt informed Colonel House, a former adviser of Wilson, who was growing impatient, that "the first version of the book is almost complete," then, at the end of April 1932, that "the book is finally finished." The only thing remaining was for the text to be revised, so, at the end of November, Freud told Max Eitingon he had learned from "his collaborator . . . when it would be possible to publish the Wilson book." It is important to remember that the situation at the Internationaler Psychoanalytischer Verlag was dire at this time and Freud was counting on the success of the book, as he did the *New Introductory Lectures* (1933a [1932]), then being printed, to restore the firm to solvency.

Nothing happened however. There were disagreements; Freud wanted to add new material that Bullitt rejected. The day after his arrival in London in June 1938, which owed a great deal to the ambassador's intervention, Bullitt finally obtained from Freud the authorization to publish the text. According to Max Schur (1972), Freud's notes and letters were supposedly burned by an absent-minded butler during Bullitt's hurried departure from Paris in 1940. "Why did my father agree, after a repeated (and quite understandable) refusal?" asked Anna Freud when the book finally made its appearance in 1966—"after the death of Mrs. Wilson" noted Bullitt.

While it is easy to understand the extent to which this text was part of Freud's preoccupation with the dangers of a personality impregnated with religious illusions and the political and economic fallout caused by the misinterpretation of external reality by the "world's leading idealist," the final result is perplexing and Freud's style comes through only in short bursts.

The subtitle, "A Psychological Study," is clear, and Freud explains that it "expresses our conviction that psychoanalysis is nothing but psychology, one of the parts of psychology, and that one does not need to apologize for employing analytic methods in a psycho-

logical study which is concerned with the deeper psychic facts" (p. xiv). This could not have been done during Wilson's lifetime, but "when . . . an individual whose life and works are of significance to the present and future has died, he becomes by common consent a proper subject for biography and previous limitations no longer exist" (p. xiv).

After an introduction written by Bullitt—"Digest of Data on the Childhood and Youth of Thomas Woodrow Wilson"—there follows the "Psychological Study" signed by both authors. The book contains thirty-five short chapters of commentary on the principal episodes of Wilson's life, from his rise to power until his paralysis in September 1919 and death on February 3, 1924. Like a pale caricature of certain essays on "psychohistory," the book is a heteroclitic patchwork of simplified psychoanalytic concepts for an ignorant public, remarks that are not without finesse, and reductive and repetitive interpretations. It is easy to see why so many readers have refused to see this as Freud's work.

This can be explained by the connection between Wilson's masochistic submissiveness and his "overpowering father" (p. 59), the Reverend J. R. Wilson. A "paternal complex," the repression of a hostility that was impossible to bear, since the father was assimilated to the supreme Being, the identification of the son with Jesus Christ and his mission as Savior of the world, the creation of an "tremendously powerful and exalted Super-Ego" (p. 60), a libido that found release in his speeches—the list of explanations is not all that long and each chapter could be concluded with the *quod erat demonstrandum* that Freud had grown fond of using during his friendship with Fliess.

But there was a fundamental difference with the cases he had discussed until then, something both authors recognized, in fact: "We shall never be able to achieve a full analysis of his character. About many parts of his life and nature we know nothing. The facts we know seem less important than those we do not know. All the facts we should like to know could be discovered only if he were alive and would submit to psychoanalysis. . . . It is a psychological study based upon such material as is now available, nothing more" (p. 35).

In fact this work, unlike that on Leonardo da Vinci and the *Memoirs* of Justice Schreber, cannot be considered a truly "psychoanalytic" work because not only is it not based on clinical experience but it makes no

attempt to illustrate a theoretical premise based on other examples taken from clinical practice. It is purely descriptive in nature, journalistic in a sense, and, like any work of this nature—although it bears Freud’s signature—the book is not an example of applied but of superficial psychoanalysis.

The concluding sentence of Freud’s preface is worth repeating, however: “We cannot, however, deny that, in this case as in all cases, a more intimate knowledge of a man may lead to a more exact estimate of his achievements” (p. xvii).

ALAIN DE MIJOLLA

*See also:* Bullitt, William C.; Ego-libido/object-libido; Group psychology; History and psychoanalysis; Politics and psychoanalysis; Psychohistory; “Why War?”

### Source Citation

Freud, Sigmund, and Bullitt, William C. (1966b [1939]). *Thomas Woodrow Wilson, Twenty-eighth president of the United States: A psychological study*. London and New York: Weidenfeld and Nicholson.

### Bibliography

- Bolzinger, André. (1991). Portrait psychologique et psychanalyse sauvage. À propos de “Le président T. W. Wilson.” *L’Évolution psychiatrique*, 56 (1), 189–200.
- Gay, Peter. (1988). *Freud: A life for our time*. London and Melbourne: Dent.
- Miller, Gérard. (1990). Préface. In Bullitt, William C., and Freud, Sigmund, *Le président T. W. Wilson*. Paris: Payot, “Petite Bibliothèque.”
- Schur, Max. (1972). *Freud: Living and dying*. New York: International Universities Press.

## THOMPSON, CLARA M. (1893–1958)

American physician and psychoanalyst Clara M. Thompson was born in Providence, Rhode Island on October 3, 1893, and died in New York City on December 20, 1958.

Thompson grew up in a religious, middle class family. She was closer to her father, while her brother Frank, nine years her junior, was closer to her mother.

Thompson was a serious student and a tomboy in elementary and high school where her goal was to be a medical missionary. In 1912 Thompson enrolled at the Women’s College of Brown University. College was a difficult time for her; she is described as quiet and lonely. A formative experience occurred in her sophomore year when she read George Eliot’s *Mill on the Floss*. Thompson deeply identified with its rebellious protagonist, Maggie. She stopped going to church and decided not to be a missionary. This precipitated a twenty-year rupture with her mother. In her senior year Thompson was engaged to be married, but her boyfriend insisted that she chose between him and medical school. She chose medical school and never married.

In 1916 Thompson began medical training at Johns Hopkins University, where she also completed her internship. She worked at St. Elizabeth Hospital under Edward Kempf and William Alanson White, and had a psychiatric residency at the Phipps Clinic where she studied under Adolph Meyer.

In 1923 Harry Stack Sullivan heard Thompson give her first scientific paper. He was very taken by her work and thus began a friendship of twenty-five years. Sullivan encouraged Thompson to go into treatment with Sándor Ferenczi, whom she first met in the spring of 1927, while he was lecturing at the New School. She went to Budapest in the summers of 1928 and 1929 and then moved to Budapest in June of 1931 where she stayed until Ferenczi’s death in 1933. Prior to moving to Budapest, in 1930, she had become the first president of the Washington-Baltimore Psychoanalytic Society.

Thompson’s treatment deeply affected her. People felt that she was deeply changed by this analysis. Ferenczi’s ideas about the impact of the real relationship between patient and analyst and the importance of real events in childhood were compatible with Sullivan’s Interpersonal Theory, but Thompson strongly disagreed with Ferenczi’s ideas about regression.

After Ferenczi’s death Thompson moved to New York where she, Sullivan, Karen Horney, William Silverberg, and later Erich Fromm met to discuss their work. Thompson taught at the New York Psychoanalytic Institute from 1934 until 1941, when she left after Horney was forced to resign. She joined with Horney, Silverberg, Robbins, and Fromm in forming the Association for the Advancement of Psychoanalysis, but

she left two years later after Horney insisted on only including medical doctors, and excluded Fromm. Thompson, Fromm, and Janet Rioch, with the help of Sullivan and Frieda Fromm-Reichmann, then started the New York Branch of the Washington School of Psychiatry, later to become the William Alanson White Institute. Thompson was co-founder and director of the William Alanson White Institute, from its creation as the New York branch of the Washington School of Psychiatry in 1943, until her death in 1958.

Thompson wrote over fifty articles, many of which are reprinted by Maurice Green in *Interpersonal Psychoanalysis. The Selected Papers of Clara Thompson* (1964). These include: “Notes on the Psychoanalytic Significance of the Choice of Analyst,” (1938) “The Role of Women in This Culture,” (1941) “Some Effects of the Derogatory Attitude toward Female Sexuality,” (1950) “Transference as a Therapeutic Instrument,” (1945) and “Counter-Transference” (1952).

Thompson was a central force in the creation of the interpersonal school of psychiatry. Thompson analyzed or supervised many of the most influential members of the second generation of interpersonal analysts who greatly expanded and extended her ideas on transference and counter-transference. Her understanding of the unique difficulties facing professional women led her to be the analyst of choice for many groundbreaking women. In addition, Thompson’s dedication to training lay analysts set an important precedent in the United States.

SUE A. SHAPIRO

*See also:* Counter-transference, Interpersonal analysis.

### **Bibliography**

- Moulton, Ruth. (1986). Clara Thompson: Unassuming leader. In L. Dickstein and C. Nadelson (Eds.), *Women physicians in leadership roles*. Washington, DC: American Psychiatric Press.
- Shapiro, Sue A. (1993). Clara Thompson, Ferenczi’s messenger with half a message. In L. Aron and A. Harris (Eds.), *Legacy of Sándor Ferenczi*. Hillsdale, NJ, and London: Analytic Press.
- Thompson, Clara. (1950). *Psychoanalysis: Evolution and development*. New York: Hermitage House.
- . (1964). *Interpersonal psychoanalysis. The selected papers of Clara Thompson* (Maurice Green, Ed.). New York: Basic.

## THOUGHT

Thought may be defined in general as mental activity, conscious or unconscious, based on the various modes of representation, including the most archaic. More narrowly, the meaning of thought may be confined to ideational activity, dependent on the faculty of judgment and on the faculty that brings into conjunction images of things and images of words. The discussion here will be restricted to the narrower conception of thought as ideational activity, but always bear in mind that the narrower meaning is deeply rooted in the more general one.

Freud approached ideational thought from three different angles, which did not necessarily overlap. The first was the “psychological” approach, as outlined in the “Project for a Scientific Psychology” (1950c [1895]) and further developed in *The Interpretation of Dreams* (1900a), “Formulations on the Two Principles of Mental Functioning” (1911b), and “Negation” (1925h). In this perspective, Freud analyzed the thought process in relation to perception, language, memory traces, and action, for which, in Freud’s view, thought was a substitute. The second approach, a “genetic” one, was a response, in essence, to the question of the origins of thought as a search for knowledge. This line of enquiry was concerned primarily with the child’s urge to find things out and sought the libidinal origins of this drive and the circumstances that set it in motion. The four main Freudian works pertinent here are *Three Essays on the Theory of Sexuality* (1905d), “On the Sexual Theories of Children” (1908c), the case history of “little Hans” (1909b), and the analysis of Leonardo da Vinci (1910c), which situate thought activity relative to the instinctual realm and describe the various fates for which thoughts may be destined: inhibition, obsessive intellectualization, or sublimation. Freud’s third approach to thought was an original way of looking, not at the actual activity of thought, but at what is expected of it. This was the “anthropological” approach, to be found notably in *Totem and Taboo* (1912–1913a), which developed the concepts of magical thought and animistic thought in relation to thought activity during childhood and in pathology.

In the “Project for a Scientific Psychology” (1950c [1895]), Freud argued that thought processes are provoked by dissonance between a memory imprinted by a wish and a cathexis that seems to belong to the wish. When the two do not coincide, a biological signal trig-

gers thought; when they do, another signal terminates such activity and precipitates a discharge (action). Sixteen years later, in “Formulations on the Two Principles of Mental Functioning” (1911b), Freud proposed a similar account of the act of judgment, which “had to decide whether a given idea was true or false—that is, whether it was in agreement with reality or not—the decision being determined by making a comparison with the memory-traces of reality” (p. 221). Already in the “Project for a Scientific Psychology,” he had stressed that it was possible for judgment to have no objective beyond itself, such as mnemonic activity, which is self-sufficient, or the examination of new perceptual elements. In Freud’s theory, the role of judgment is in fact circumscribed both by recollection and by investigation.

In “Formulations on the Two Principles of Mental Functioning,” Freud defined thought as an activity that enabled the psychic apparatus to postpone discharge (action) when it would be inappropriate, and that brought together the impressions left by objects (“presentations”) and their linguistic designators (words). Freud also set off a “species of thought-activity . . . kept free from reality-testing and . . . subordinated to the pleasure principle alone,” namely fantasizing, which began with children’s play and survived in day-dreams (1911b, p. 222). Here Freud was broadening the concept of thought in a way also met with in *The Interpretation of Dreams* (1900a), where Freud divided the notion of “dream-thoughts” into “essential dream-thoughts” (the dream itself, uncensored) and “latent dream thoughts.” The latter comprise the much broader set of thoughts originating in the multiple channels linking the latent to the manifest and of associations arising from contiguity and resemblance and produced during the work of interpretation. Even though an intellectual activity, such as calculation or deduction, may appear in a dream, “an act of judgment in a dream is only a repetition of some prototype in the dream-thoughts,” a repetition that may be “so neatly employed that to begin with it may give the impression of independent intellectual activity in the dream” (1900a, p. 459).

Whereas the psychological approach offered a description of thought activity, the genetic approach raised an entirely different question: What makes us think? The question calls for identifying causes sufficient to account for the large quantities of libidinal energy devoted to thought activity. Freud posited an “instinct for knowledge or research” (1905d, p. 194).

This independent and atypical instinct was not bound to any erogenous zone but drew pleasure from other so-called component instincts, namely the instinct to see and the instinct for mastery. Freud needed the difficult concept of sublimation here to explain this diversion of the instinct’s aim and the change of its object. As early as the “Project for a Scientific Psychology” (1950c [1895]), Freud had pointed up the importance of the visual function for understanding. He stressed it even more in his essay on Leonardo da Vinci, who famously observed that the eyes are “the window to the soul.” Freud’s logical progression from the desire to look (*Schaulust*) to the instinct for knowledge (*Wisstrieb*) was based primarily on the fact that the wish to see was not satisfied with contemplating or even scrutinizing, but strove to compare. The perception of difference and the comparison of several variants of what is recognized as the same thing are steps toward the abstraction that enables us to think and classify.

According to Freud, the instinct for knowledge is awakened when children become interested in birth—a practical interest aimed at coping with the arrival of younger siblings (1908c). This curiosity, not satisfied by the parents’ answers, leads the child to engage in intense theorizing and to devise answers, sometimes the classical ones, sometimes not, to unanswered questions. This theorizing is associated with masturbation and, like it, remains unfulfilled. Freud considered this lack of fulfillment as one of the sources of intellectual inhibition.

In his write-up of the case of “little Hans” (1909b), his write-up of the case of the “Wolf Man” (1918b [1914]), and his analysis of Leonardo da Vinci (1910c), Freud explores the fate of this instinct for knowledge, which may either fall prey to inhibition, in tandem with a violent surge of sexual repression, or overcome inhibitory forces and re-emerge from the depths of the unconscious in the form of an obsessive thought. Or again, in the “rarest and most perfect” cases, the instinct may escape both fates: “The libido evades the fate of repression by being sublimated from the very beginning into curiosity and by becoming attached to the powerful instinct for research as a reinforcement” (1910c, p. 80).

Melanie Klein continued this line of investigation by developing the notion of an *epistemophilic instinct*, a very early curiosity concerning the inside of the mother’s body and the babies presumably found there. Beginning with a consideration of the sadistic and destructive dimension of this curiosity, she pointed out that one of the sources of intellectual inhibition was the

inability to obtain clarity of thought because of anxiety over what might be found (Klein, 1931).

After its fashion, Freud's third approach to thought, the anthropological approach, also addressed the question of the origin of the human desire to know. Freud felt that primitive thought was characterized by a belief in the "omnipotence of thoughts," a term that he had originally used in connection with an obsessional neurotic, the "Rat Man" (1909d, pp. 233–235), and that denoted an overestimation of the power of thought, resulting in things being erased by their representations. In such cases, intellectual processes are strongly sexualized, and this formed the basis of the belief in the omnipotence of ideas, which led primitive man to attempt to control the world with magic (1912–1913a, p. 89).

But if Freud believed that the question of the origin of life sparked the instinct for knowledge in children, by contrast, "the survivors' position in relation to the dead first caused primitive man to reflect" (1912–1913a, p. 93). He added, however, that this was not a purely intellectual problem, but rather an emotional conflict that had to be resolved. For children, just as for primitive humans, Freud thus rejected the notion of a primary need for causality; practical ends always predominate: "It is not to be supposed that men were inspired to create their first system of the universe by pure speculative curiosity. The practical need for controlling the world around them must have played its part" (1912–1913a, p. 78).

Whether Freud is concerned with the connection between the thought of the obsessive neurotic and that of primitive people, or with how the philosopher resembles the schizophrenic in mistaking words for things, his wide-ranging reflections on thought and its origins raise a multitude of issues, including that of psychoanalytic thought itself. For, as Freud himself wrote, "When we think in abstractions, there is a danger that we may neglect the relations of words to unconscious thing-presentations, and it must be confessed that the expression and content of our philosophizing then begins to acquire an unwelcome resemblance to the mode of operation of schizophrenics" (1915e, p. 204).

SOPHIE DE MIJOLLA-MELLOR

*See also:* Action-thought (H. Kohut); Alpha-elements; Animistic (thought); Certainty; Civilization (*Kultur*); "Claims of Psychoanalysis to Scientific Interest"; Con-

cept; Contradiction; Doubt; Hermeneutics; Ideology; Intellectualization; Jokes; Logic(s); Magical thinking; Need for causality; Omnipotence of thought; Operational thinking; Philosophy and psychoanalysis; Pleasure in thinking; Psychic energy; Rationalization; Sense/nonsense; Symbolism; Telepathy; Thought identity; Thought-thinking apparatus; Unconscious concept; Working-through.

### **Bibliography**

- Anzieu, Didier. (1994). *Le penser: Du moi-peau au moi-pensant*. Paris: Dunod.
- Freud, Sigmund. (1900a). The interpretation of dreams. *SE*, 4: 1–338; 5: 339–625.
- . (1905d). Three essays on the theory of sexuality. *SE*, 7: 123–243.
- . (1908c). On the sexual theories of children. *SE*, 9: 205–226.
- . (1909b). Analysis of a phobia in a five-year-old boy. *SE*, 10: 1–149.
- . (1909d). Notes upon a case of obsessional neurosis. *SE*, 10: 151–318.
- . (1910c). Leonardo da Vinci and a memory of his childhood. *SE*, 11: 57–137.
- . (1911b). Formulations on the two principles of mental functioning. *SE*, 12: 213–226.
- . (1912–1913a). Totem and taboo. *SE*, 13: 1–161.
- . (1915e). The unconscious. *SE*, 14: 159–204.
- . (1918b [1914]). From the history of an infantile neurosis. *SE*, 17: 1–122.
- . (1925h). Negation. *SE*, 19: 233–239.
- . (1950c [1895]). Project for a scientific psychology. *SE*, 1: 281–387.
- Klein, Melanie. (1931). A contribution to the theory of intellectual inhibition. *International Journal of Psycho-Analysis*, 12, 206–218.
- Mijolla-Mellor, Sophie de. (1992). *Le plaisir de pensée*. Paris: Presses Universitaires de France.

---

## **THOUGHT IDENTITY**

Thought pursues identity in order to unify its causality; the term *thought identity* designates the process of cognitive determination that it forms with its object, even if the latter is of an imaginary order.

With Sigmund Freud's work in *The Interpretation of Dreams* (1900a), the problem of identity saw a radically new approach in relation to the notion of perceptual identity and the respective aims of the primary and secondary processes.

Formal logic, a legacy from Aristotle, establishes identity as the criterion of unity of the thinkable, as the condition of possibility of thought itself, independent of its "matter." Practical thought makes effectiveness—that is, the successful transformation of the object—the criterion for appropriate, pragmatic thought. Imaginary or fantasmatic thought seeks its "thought identity" in independence—a direct source of pleasure—relative to practical or theoretical ends.

Philosophy, especially speculative philosophy (Hegel) sees the idea, the absolute determination of the concept, as the attainment of the goal of thought, in which an identity relation exists among the relative and exclusive practical, theoretical, and imaginary identities, as absolute knowledge. In this view, "ideological" thought identity represents the alienated current of the goal of identity pursued by a mode of thinking whose method is always and everywhere the active immobilization of thought, resulting in dogmatism, exclusivism, negation of the thought of the other, "group think," and the like.

Freud's distinction between the primary and secondary processes makes it possible to differentiate between thought identity, which is the aim pursued by thought by means of the secondary process, and perceptual identity, which is the aim pursued by hallucination by means of the primary process. In Freud's view, the aim is "practical" in that it always involves passing from one situation to another in accordance with desire. Hallucination short-circuits the detour necessitated in the effort of thinking, meaning that pleasure is not its condition even though it may remain its aim, and it takes the route of the death instinct rather than that of the life instinct; this explains the connection between thought identity and Eros. As Sophie de Mijolla-Mellor showed in *Le Plaisir de pensée* (1992), Freud distinguished practical and fantasmatic thought from thought in the form of true research or critical thinking; the latter do not make pleasure and its production the criteria for thought identity. For this reason, critical thinking and pure research alone are capable of producing a cogitative determination that is independent of perceptual identity.

DOMINIQUE AUFFRET

*See also:* Experience of satisfaction; Perceptual identity.

### **Bibliography**

- Freud, Sigmund. (1900a). The interpretation of dreams. Parts I and II. *SE*, 4–5.
- Lagache, Daniel. (1961). La psychanalyse et la structure de la personnalité. Colloque de Royaumont, 1958. *La Psychanalyse*, 6.
- Mijolla-Mellor, Sophie de. (1992). *Le plaisir de pensée*. Paris: Presses Universitaires de France.

---

## **THOUGHT-THINKING APPARATUS**

The term *thought-thinking apparatus*, used by Wilfred R. Bion, emphasizes, from a psychoanalytic standpoint, the distinction between representational aspects (elements of thought such as conceptions and concepts) and operational aspects (discharge and elaboration of thoughts). It is to this latter aspect that Bion refers when he speaks of the "thinking apparatus" (or "thought-thinking apparatus") that develops for manipulating thoughts.

In his 1962 article "A Theory of Thinking," where he first articulated the theory he was to further develop in four volumes published from 1962 to 1967, Bion draws a distinction between the creation of thoughts and their use for reducing tensions and deferring action (both functions that Freud had already attributed to thought). Bion posits that thoughts are anterior in origin to the work of thinking (produced by the thought-thinking apparatus). This approach can be contrasted to the truism of nineteenth-century materialist and physiological psychology that held that the brain secretes thoughts, just as the liver secretes bile.

According to Bion, the infant's first sensory or affective data correspond to a state of frustration, a sensation of the absence of the breast, a sensation of a "hole." To get out of this state, the baby must eject or modify this sensation, which corresponds to a primitive thought or protothought. At this stage, according to Bion, there is no clear distinction between mental representation and emotional or sensory experience.

In a second stage the capacity for thinking appears, dependent upon the infant's ability to withstand frustration, endure delay, and transform the emptiness left by the absence of the breast into a thought. In Bion's



view, in the course of development the “non-thing” or “non-object” becomes a thought. The breast that is present is not a thought, but will finally become the thing-in-itself (which is not “phenomenal” because it is seemingly “known”).

This theory of the origins of thought is slightly different from that of Sigmund Freud. Thought is no longer considered as a “hallucinatory substitute for desire.” (SE 22, p. 221) It is not the absent breast that is “thought” in order to appease hunger, but rather the “non-breast,” which is the first thought and which can then be the object of “thinking.” In Bion’s theory, thought is partly objectified instead of being deobjectified, as in the theory of the autonomous ego.

Bion’s model is close to Freud’s model of the *fort-da* game involving the wooden reel: The experience of frustration leads to the creation of other possibilities (fantasies, symbols, actions) that provide a new means to achieve satisfaction in reality. Once the earliest thoughts relating to the “non-object” have been established, the psyche must develop a thinking apparatus to rid itself of thoughts linked to frustration. This development necessarily occurs through contact with the mother, by means of projective identification mechanisms that take the form of a satisfying container-contained relationship, and through a dynamic interplay between paranoid-schizoid and depressive positions.

In the earliest case of a container-contained relation (symbolized ♀♂), the mother’s repeated positive experiences with the child, along with the points of contact between the child’s projections and the “reverie” of the mother, produce the model that the child can then introject as part of the thinking apparatus.

The interplay between paranoid-schizoid and depressive positions (symbolized PS D) develops the thinking apparatus. The earliest splitting operations in the structuring of the psyche, the necessary separation between “good object” and “bad object,” and the choices made in what Henri Poincaré conceptualized as “selection of facts” (but which Bion prefers to call “selected facts”) are dependent upon the paranoid-schizoid position. The depressive position plays a role in the acceptance of the loss that is implicit in all thought, and is also fundamental to progressive integration at the level of thought; that integration process is also dependent upon the container-contained mechanism.

One might also wonder: What can one do with thoughts, besides thinking them? Bion describes several types of thought disturbances linked to the difficulty of maintaining disciplined and cohesive thought. These disturbances are the result of a collapse either at the level of the representational elements of thought (in schizophrenia) or at the level of the activity of thinking, or the thinking apparatus itself (in hysteria or obsessional neurosis).

PEDRO LUZES

*See also:* Attention; Bion, Wilfred Ruprecht; Container-Contained; Maternal reverie, capacity for; Proto-thoughts; Thought.

### **Bibliography**

- Bion, Wilfred Ruprecht. (1962). *Learning from experience*. London: Heinemann; New York: Basic Books.
- . (1962). A theory of thinking. *International Journal of Psycho-Analysis*, 43, 4–5; reprinted in *Second thoughts*. London: Heinemann, 1967.
- . (1963). *Elements of psycho-analysis*. London: Heinemann.
- . (1965). *Transformations: Change from learning to growth*. London: Heinemann.
- . (1970). *Attention and interpretation*. London: Tavistock Publications.

---

## **“THOUGHTS FOR THE TIMES ON WAR AND DEATH”**

There are two essays in Sigmund Freud’s “Thoughts for the Times on War and Death,” one on disillusionment and the other on our relation to death as revealed or modified by war. Freud wrote them in March and April 1915, six months after war was declared. Although he did not hide his nationalism, the tone is that of a “European” of the Enlightenment more than that of a partisan, especially in the first essay.

The theme of disillusionment is one Freud returns to often. It features in *The Future of an Illusion* (1927c) and in *Civilization and Its Discontents* (1930a). Here, it is the ideals of the community of mankind, or at least of Europeans, that are damaged and unsettled by war. Freud emphasizes that psychoanalysis has always maintained that behind the civilization we have struggled so hard to create (“Civilized” Sexual Morality and

Modern Nervous Illness,” 1908d), there exist drives that are neither good nor bad in themselves but are classified as such because of their relation to the needs and requirements of the human community. As a result regression is always possible and the reshaping of drives on which the inclination to civilization is based can cause reversion to a previous stage, permanently or temporarily, through various events, primarily war. However, Freud concluded with a question: “Why do individual peoples despise themselves, hate themselves, abhor themselves and others, even during times of peace, and why does every nation treat the others in this way? This is certainly an enigma.”

Bernd Nitzschke discovered the text on which the second essay is based. It appeared in a speech given at the Jewish Masonic lodge of B'nai B'rith in Vienna on February 15, 1915. It discusses our relationship to death and, in reality, has little to say about war, even though this was the pretext for the article. Freud reminds us that individual death cannot be represented unless it appears in a fantasy that negates its terror because we appear in it as a spectator. “In the unconscious each of us is convinced of our immortality.” Consequently, the interpretation given of the causes of death has always tended to treat death as an unfortunate accident rather than a necessity.

However, having exposed the way thought distances us from the inevitability of death, Freud then goes on to show how it is eroticized in two areas: the taking of risks in our active life and relating the death of others with which we identify in literature. He goes on to say that “in fiction we find this plurality of lives that we need.” Civilized man therefore has a contradictory attitude toward death since he denies it for himself and considers it as something that makes life valuable. The same is true of primitive man, who treats death as real in murder and unreal as far as it affects him personally. However, Freud shows that “it is not the intellectual enigma or each particular instance of death but the conflict of feelings experienced during the death of people who are loved and at the same time strangers and hated that has given rise to the spirit of research in humankind.” He then adds that the moral commandments also come into being at this time, the most important of them being the interdiction of murder. This leads him to conclude: “If we are judged according to our impulses of unconscious desire, we are ourselves like primitive men, a band of assassins.”

SOPHIE DE MIJOLLA-MELLOR

See also: Aggressiveness/aggression; Altruism; First World War: The effect on the development of psychoanalysis; “On Transience”; Reaction formation; “Why War?”

### Source Citation

Freud, Sigmund. (1915b). Zeitgemässes über Krieg und Tod. *Imago*, 4: 1–21; *GW*, 8, 324–355; Thoughts for the times on war and death. *SE*, 14: 273–300.

### Bibliography

Le Rider, Jacques. (1992). Un texte retrouvé: La première version d’*Actuelles sur la guerre et sur la mort* (part 2). *Revue internationale d’histoire de la psychanalyse*, 5, 599–611.

Nitzschke, Bernd. (1991). Freuds vortrag vor dem israelitischen humanitätsverein “wie” des Orden B'nai B'rith: “Wir und der Tod” (1915). Ein wiedergefundenes document. *Psyche*, 2, 97–131.

---

## THREE ESSAYS ON THE THEORY OF SEXUALITY

According to James Strachey, the *Three Essays on the Theory of Sexuality* should be considered, after *The Interpretation of Dreams*, to be Sigmund Freud’s “most momentous and original contributions to human knowledge” (Freud, 1905d, p. 126). In general, most psychoanalysts would agree. The immediate influence of the *Three Essays* was profound, and fostered change in the way that people thought, behaved, and learned about sexuality; this influence abides today.

Published soon after the turn of the twentieth century, the book’s somewhat scandalous profile heightened its impact. Its contentious reputation was not due, in all likelihood, to the first of Freud’s three essays, which concerned perversions. Havelock Ellis had discussed sexual aberrations and Freud cited and praised his work; Richard von Krafft-Ebing and others had strived diligently to create a literature concerned with sexual deviations. The medical context of these publications justified their sexual content, and they were received with approbation. Nor did the last of the *Three Essays*, on “The Transformations of Puberty” seem to provoke much controversy at a time when personal needs, desires, and social practices only underscored the omnipresence of sexuality.

Rather, the controversy (and enthusiasm) that greeted Freud’s brief volume was primarily due to the

second essay, in which he discussed sexuality in infancy and childhood. From a present-day perspective, it is difficult to imagine the vehement reactions provoked by suggesting the existence of infantile sexuality.

Indeed, sexuality in infancy and childhood is the central theme of the book. Freud's discussion of adult sexual aberrations links them to unexpected or abnormal events during childhood. He similarly understands puberty as the sum of modifications acting upon infantile sexuality. These ideas were clearly spelled out in the first edition of the *Three Essays* in 1905.

The first essay concerns "The Sexual Aberrations." In his treatment of homosexuality (for which he used the term *inversion*), Freud disputed and refuted common wisdom that invoked theories of degeneracy or offered innate or "constitutional" factors as explanatory. He acknowledged that such factors may be at the root of the perversions in some cases, but to those must be added the decisive participation of accidental causes—that is, childhood events that affected sexuality. Such events comprise the only available material for psychoanalytic work. In effect, the etiology of neurosis that Freud had previously proposed, as early as 1896 with reference to hysteria, was here reasserted and further developed.

Starting from two basic concepts, instinct and object, Freud stated that "it seems probable that the sexual instinct is in the first instance independent of its object" (p. 148). He stressed that one must distinguish between types of perversion, according to whether the sexual anomaly is related to the object (as with homosexuality or zoophilia) or to the aim, that is, to the activities that lead to sexual gratification. Freud discussed homosexuality in this general theoretical context—that is, how, from a developmental standpoint, a person would make either a homosexual or heterosexual object choice, the latter representing as much of a problem as the former. Either path might be taken in consequence of the anatomic-physiologic and psychic bisexuality that characterizes every human being, a hypothesis that Freud explicitly attributed to Wilhelm Fliess. Freud sustained his argument with the concept of *component instincts*—several independent impulses, each related to an erotogenic zone or somatic source without being integrated with each other. One can thus better understand why numerous perversions are characterized by sexual behavior that preferentially involves the oral, and especially the anal,

erotogenic zones—they are, that is to say, the result of psychic functions controlled by component instincts. (Component instincts and normal gratifications of childhood would be further discussed in the second essay.) Whereas neurotics repress the desire for instinctual gratification, the anomaly of perversion in adults resides in the fact that their sexual practices are permanently and predominantly based on satisfying component instincts. From this reasoning emerged Freud's concept that "*neuroses are, so to say, the negative of perversions*" (p. 165, Freud's italics), an idea which he had previously taken up in a letter to Fliess (January 24, 1897; 1950a).

Ideas developed in the first essay led logically to the second, which focused on sexuality in infancy and childhood. Freud pointed to the lack of knowledge on this subject while noting, at the same time, that it would be sufficient to carefully observe young children without hastening to declare sexual manifestations as abnormal. Every adult was once a child and should in principle be able to recall childhood in more than a fragmentary way, but most do not. Freud added two important observations. First, infantile amnesia affects everything concerning sexuality in childhood. Second, the strong moral condemnation that impacts all manifestations of sexuality leads to repression or gratification through sublimation.

Freud went on to advance a highly audacious and fertile idea that would lead to many further developments in psychoanalysis, both theoretical and clinical, and which would influence both his own later thought and that of his successors. He stated, in effect, that sucking activity observed in the infant should be considered as the prototype for all future sexual gratification. Thumb-sucking (or "sensual sucking") "consists in the rhythmic repetition of a sucking contact by the mouth (or lips). There is no question of the purpose of this procedure being the taking of nourishment" (pp. 179–180). Thumb-sucking has no other aim but pleasure and is separate from, but attached to or initially dependent upon, the need for nourishment. "To begin with, sexual activity attaches itself to functions serving the purpose of self-preservation and does not become independent of them until later" (p. 182). Herewith emerges implicitly the notion of *anaclysis*, which would later play a major role in developmental theory. Freud explicitly states that oral gratification is a prototype for every sexual gratification, is pleasurable in itself, and is autoerotic inasmuch as it does not

require any other object than the infant itself. He writes that the infant seems to be saying, “It’s a pity I can’t kiss myself” (p. 182). Here we find one of the major sources of discomfort provoked by the second of the *Three Essays*.

Freud, like most psychoanalysts after him, would view any controversy that emerged around the notion of infantile sexuality to be the result of a misunderstanding. If sucking is to be considered sexual and to lie at the root of all later sexuality, this should be understood in the context of an extended definition of the concept of sexuality itself, not confounded with, or reduced to, genital sexuality. However, objections to the idea of infantile sexuality would grow still more vehement with Freud’s further declaration that sensual sucking is masturbatory in nature and serves as a prototype for such gratification which, in addition, shifts from the labial zone to the anal zone, and lastly to the genital zone.

In addition, in a highly rational argument, Freud presented a further fundamental concept. The infant, due to the diverse and polyvalent character of erotogenic zones as invested by instinct and by the various means of gratification, may be characterized as possessing a “polymorphously perverse disposition.” Obviously, this is not to say that the child will become perverse as an adult; quite the contrary, this is merely the foundation of the normal trajectory of psychosexual development. By contrast, adult perversion is characterized by the abnormal persistence of infantile characteristics. In so-called normal development, the genitals become the dominant erotogenic zone, other erotogenic zones become subordinate to it, and there follows integration of the sources of sexual excitation and modes of sexual satisfaction.

In the last of the three essays, Freud described the “The Transformations of Puberty.” In the 1905 edition, this essay might have seemed less original than the previous section. Nevertheless, Freud examined three central themes in psychoanalysis—the libidinal economy of the onset of puberty, female and male sexuality, and object relations.

Again, Freud raised the notion of the integration, “under the primacy of the genital zones” (p. 208), of component instincts and erotogenic zones which serve as gateways to preliminary gratification preceding complete sexual intercourse through coitus and orgasm. But then, Freud faced a problem, the solution

to which he found difficult to accept. He had long reasoned that pleasure lowers tension while unpleasure raises it, writing that “I must insist that a feeling of tension necessarily involves unpleasure” (p. 209). But if the very activity that seeks to decrease tension is perceived as a pleasure, how then to understand the search for sexual excitement, which commonly characterizes every sexual act (including foreplay) before culminating in orgasm and relaxation? Confronting the issue, Freud pursued it in connection with sexual chemistry, largely speculative at the time. In fact, the problem remained without a solution in the 1905 edition; it would only be much later, in such works as “The Economic Problem of Masochism” (1924c), that Freud returned to it in a more satisfactory way.

Freud discussed a second theme in the third essay in a section titled “The Differentiation between Men and Women,” in which he asserted rather baldly that “The sexuality of little girls is of a wholly masculine character” (p. 219), and that “it would even be possible to maintain that libido is invariably and necessarily of a masculine nature, whether it occurs in men or in women” (p. 219). The clitoris, which Freud viewed as the distaff equivalent of the penis, is the site of masturbatory pleasure for little girls. In the woman, the clitoris may be viewed as the organ of forepleasure that transmits excitement to the “adjacent female parts,” writes Freud, “just as—to use a simile—pine shavings can be kindled in order to set a log of harder wood on fire” (p. 221). Freud’s subsequent discussion of these ideas, particularly in *New Introductory Lectures on Psychoanalysis* (1933a [1932]), would eventually incite considerable and lively controversy regarding the nature of female sexuality.

Still another theme in the third essay concerned “The Finding of an Object” during the transformations of puberty and (as we would say today) adolescence. In 1905, Freud still subscribed to an overly simplistic theory that he would later modify in fundamental ways. To infantile sexuality, which he supposed to be essentially auto-erotic, he opposed object-directed sexuality developed during puberty. The primal object, the mother’s breast, has by then been long lost, so that libidinal investment in the sexual partner after puberty is in fact a “rediscovery,” Freud notes. He adds, “The finding of an object is in fact a refinding of it” (p. 222). This was a proposition that spawned fruitful and interesting developments. In effect, from this point on, Freud acknowledged the object-relations nature of

infantile sexuality. He went on to consider infantile anxiety and the “barrier against incest” (p. 225) that forbids sexual relations between child and parent. Freud clearly established here what, beginning in 1910, he would call the “Oedipus complex.” The *Three Essays* ends with Freud’s summary of the major themes of the book.

This in brief reprise is Freud’s rich and provocative *Three Essays* as the book was published in 1905. But to understand its place in terms of Freud’s later work, it is important to realize that he revised the text with each new edition, of which there were six in his lifetime. He is not known to have considered publishing an entirely new edition, such as might have seemed necessary in light of all the developments in psychoanalytic theory. In any event, from 1910 to 1924 Freud made a host of emendations, some of which were quite significant yet difficult to reconcile with the original text to which they were attached. Freud himself admitted that this could create difficulties for the reader. In a later paper, “The Infantile Genital Organization” (1923e), he wrote, “Readers of my *Three Essays on the Theory of Sexuality* will be aware that I have never undertaken any thorough remodeling of that work in its later editions, but have retained the original arrangement and have kept abreast of the advances made in our knowledge by means of interpolations and alterations in the text. In doing this, it may often have happened that what was old and what was more recent did not admit of being merged into an entirely uncontradictory whole” (p. 141).

The *Standard Edition* accurately indicates all the modifications, suppressions, and additions to the text as Freud revised it in 1910, 1915, 1920, and also 1924; the 1915 emendations are particularly important, appearing as they do during the period that he wrote his papers on metapsychology; so too those of 1920, which came during the transition to the second theory of instincts and what is sometimes referred to as the “second topography” or structural theory. All these emendations appear either as notes at the bottom of the page, sometimes numerous and often quite long, or are included as extensions within the text itself. Three of these extended interpolations are of particular importance.

In the second essay, a section added in 1915, on “The Sexual Researches of Childhood” fundamentally reprises the Freud’s work in “On the Sexual Theories of Children” (1908c) and in “Analysis of a Phobia in a Five-Year-Old Boy” (1909b).

Another section, also added to the second essay in 1915, discusses “The Phases of Development of the Sexual Organization” (p. 197ff). This represented a major departure inasmuch as Freud introduced the notion of pregenital organizations—oral and anal stages—preceding the genital organization. In 1923, he added a note to the emendation itself in which he mentioned that he had advanced that same year (1923e) the idea of an intermediary stage, called infantile genital organization. “This phase, which already deserves to be described as genital, presents a sexual object and some degree of convergence of the sexual impulses upon that object; but it is differentiated from the final organization of sexual maturity in one essential respect. For it knows only one kind of genital: the male one. For this reason I have named it the ‘phallic’ stage of organization” (pp. 199–200). This idea implies, importantly, that the development of object choice arises in two periods separated by latency. First, from the first stage of infantile genital organization, then once again, after the final genital organization that emerges at puberty.

In the third essay, a section added in 1920 concerning libido theory largely summarizes Freud’s seminal article on narcissism (1914c), in the context of the economic problem (pleasure/unpleasure) of sexual excitation and discharge.

In sum, the *Three Essays* is indeed one of Freud’s major works. However, it would be a mistake to imagine that, at first publication in 1905, it was entirely novel in terms of Freud’s own thinking. So far as infantile sexuality is concerned, the text represents a key moment on a long path, pursued over the course of at least a decade and marked by progress and reversal, doubt and hesitation. In fact, the question of infantile sexuality arose with Freud’s theoretical efforts to create an etiology of neurosis, and can be traced to *Studies on Hysteria* (1895d). In Freud’s early view, hysteria, and neuroses more generally, are pathological conditions triggered by a sexual “seduction” sustained in childhood. But “sexual” for whom? The adult “seducer,” clearly; but, for the child “seduced,” what do we mean by “sexual”?

Freud wrote to Fliess on October 8, 1895, (letter 29) that he suspected “that hysteria is conditioned by a primary sexual experience (before puberty) accompanied by revulsion and fright; and that obsessional neurosis is conditioned by the same accompanied by pleasure” (1950a, p. 126). Just a week later, on October 15, 1895,

(letter 30) Freud wrote Fliess with some excitement, “Have I revealed the great clinical secret to you, either in writing or by word of mouth? Hysteria is the consequence of a presexual *sexual shock*. Obsessional neurosis is the consequence of presexual *sexual pleasure* later transformed into guilt (p. 127).

One can sense Freud’s dilemma. Is “presexual” sexual? Does infantile sexuality exist? No, if the incident only arises later as a memory. Yes, if it incites “pleasure” in the child—but this occurs only in those who will later develop obsessional neurosis, and these are, in fact, boys. “In [cases of obsessional neurosis] the primary experience has been accompanied by pleasure. It is either an active one (in boys) or a passive one (in girls)” (“Manuscript K” in Freud 1950a, p. 149). He adds that hysteria “necessarily presupposes a primary unpleasurable experience—that is, one of a passive kind. The natural sexual passivity of women accounts for their being more inclined to hysteria (p. 154). Thus, at this stage, some ten years before the *Three Essays*, Freud was far from seeing infantile sexuality as part of every child’s experience; he believed it might only in boys, some of whom, taking pleasure in being “seduced,” would later suffer from obsessional neurosis.

This early state of affairs clearly did not satisfy Freud. On one hand, he was tempted to assert the universality of infantile sexuality, while on the other, he hesitated before the audacity of it. Soon thereafter, in “Further Remarks on the Neuro-Psychoses of Defence” (1896b), he tried a kind of compromise, suggesting that pathogenic trauma acts in two stages, that “it is not the experiences themselves which act traumatically but their revival as a *memory* after the subject has entered on sexual maturity” (p. 164, Freud’s italics). In other words, the childhood trauma (which is traumatic, stressed Freud, because the child suffers a frightening assault, the nature of which he or she does not understand) will become sexual only in puberty. By this view, there is no infantile sexuality strictly speaking, and yet, one must admit “[E]ven the age of childhood is not wanting in slight sexual excitations” (“The Aetiology of Hysteria,” 1896c, p. 202). If infantile sexuality were universal, however, does the trauma theory collapse? Freud noted that, “It is true that if infantile sexual activity were an almost universal occurrence the demonstration of its presence in every case would carry no weight” (pp. 209–210).

Facing these theoretical difficulties, with direct implications for clinical practice, and also perhaps

facing his own resistances, Freud would need another ten years to develop a coherent theory of infantile sexuality. Understanding the progression of his thought can produce a better appreciation of the audacity and novelty of the *Three Essays*.

ROGER PERRON

*See also:* Autoeroticism; Childhood; Libidinal stage; Perversion; Psychosexual development; Puberty; Sexuality.

### Source Citation

Freud, Sigmund. (1905d). Drei abhandlungen sur sexualtheorie, *GW*, 5: 29–145; Three essays on the theory of sexuality. *SE*, 7: 123–243.

### Bibliography

Brusset, Bernard. (1992). *Le developpement libidinal*. Paris: Presses Universitaires de France.

Freud, Sigmund. (1896b). Further remarks on the neuro-psychoses of defence. *SE*, 3: 157–185.

———. (1896c). The aetiology of hysteria. *SE*, 3: 186–221.

———. (1908c). On the sexual theories of children. *SE*, 9: 205–226.

———. (1909b). Analysis of a phobia in a five-year-old boy. *SE*, 10: 1–149.

———. (1914c). On narcissism: An introduction. *SE*, 14: 67–102.

———. (1923e). The infantile genital organization (An interpolation into the theory of sexuality). *SE*, 19: 141–145.

———. (1924c). The economic problem of masochism. *SE*, 19: 155–170.

———. (1933a [1932]). New introductory lectures on psycho-analysis. *SE*, 22: 1–182.

———. (1950a [1887–1902]) Extracts from the Fliess papers. *SE*, 1: 173–280.

Freud, Sigmund, and Breuer, Josef. (1895d). Studies on hysteria. *SE* 2.

Laplanche, Jean. (1990). *Life and death in psychoanalysis*. Baltimore, MD: Johns Hopkins University Press.

---

## TICS

Tics can be described as abnormal movements characterized by suddenness, inopportune occurrence,

nonproductivity, and variability. They can affect the muscles of the face, neck, or shoulders, and are sometimes generalized. We distinguish between simple tics, which are often transient, multiple tics, and the chronic tics found in Gilles de la Tourette's syndrome.

In *Studies on Hysteria* (1895), Sigmund Freud posited that tics are a compromise between an idea and its counter-idea (countercathexis) and constitute a particular mode of expression of neurotic conflicts. In the view of Sándor Ferenczi, subjects with tics, owing to the very fact of their strong narcissism or a fixation at this stage, have an increased tendency toward discharge and a reduced capacity for psychic binding. A traumatic memory that affects the body-ego spontaneously comes to the fore each time it has the opportunity to do so: Tics are thus the hysteria of the ego. Noting that tics have a veritable muscular eroticism, Ferenczi considered them the equivalent of repressed masturbation. He also drew attention to the importance of anal-sadistic components in tics and to the connection between them and coprolalia.

According to Melanie Klein, tics are based on genital, anal-sadistic, and oral tendencies directed against the object; her uncovering of these original object relations upon which tics are based led her to consider them as a secondary narcissistic symptom. She confirmed Ferenczi's conclusion—equating tics with masturbation—but added that masturbatory fantasies are closely linked to them. Analysis of these masturbatory fantasies appears as the key to understanding the tic. Behind the homosexual content of these fantasies can be discerned the child's identification with the father, that is, the heterosexual fantasy of sexual relations with the mother. The sublimation of these fantasies in other interests leads to the disappearance of the tic.

Margaret Mahler discussed "organ neurosis." Subjects with tics experience the drives as mechanical events that are in a sense foreign to the ego. Otto Fenichel viewed tics as a pregenital conversion comparable to stuttering, which Karl Abraham had noted; for Abraham, the tic was a symptom of conversion to the anal-sadistic stage.

Serge Lebovici proposed a psychosomatic explanation: Unrepresented excitation can lead to uncontrolled psychomotor discharges. Tics have the weight of an unelaborated discharge, but on the therapeutic level, the latent meaning can be sought by means of construction. He noted the fairly close relationship between isolated or complex tics and the structured

completedness of obsessional neuroses, but at the same time mentioned that they are also found with conversion hysteria or in psychotic organizations. According to Bernard Golse, obsessive traits with fixation on the aggressive tendencies of the anal-sadistic stage are discernible in the subject with a tic; but whereas with obsessional neurosis the aggressive content is not apparent because it is repressed by the visible ritual, with tics, the aggressiveness is directly externalized in motricity, without prior mental working over of the conflicts.

The etiology of tics is complex. The difficulties described occur in children who show a neurobiological predisposition, and are registered within an intersubjective relational economy that contributes to their persistence.

CHRISTINE PAYAN

See also: Emmy von N., case of; Mahler-Schönberger, Margaret; Repetition.

### **Bibliography**

- Abraham, Karl. (1954). Contribution to a discussion on tic. In *Selected papers of Karl Abraham, M.D.* (pp. 323–325; Douglas Bryan and Alix Strachey, Trans.). London and New York: Basic. (Original work published 1921)
- Ferenczi, Sándor. (1926). Psycho-analytical observations on tic. In *The selected papers of Sándor Ferenczi, M.D.*, vol. 2: *Further contributions to the theory and technique of psychoanalysis* (John Rickman, Comp.; Jane Isabel Suttie et al., Trans.). New York: Basic. (Original work published 1921)
- Golse, Bernard. (1983). Pour une psychopathologie ou une psychogenèse des tics de l'enfant: Une revue de la littérature. *Actualités psychiatriques*, 1, 51–56.
- Klein, Melanie. (1948). *Contributions to psychoanalysis 1921–1945*. London: Hogarth Press.
- Mahler, Margaret. (1949). A psychoanalytical evaluation of tics in a psychopathology of children. *Psychoanalytic Study of the Child*, 3 (4), 279–310.

---

### **TIME**

The notion of *time* in psychoanalysis intersects several other concepts such as repetition, regression, fixation, and rhythm, though Freud also discussed the idea of

time directly. He began by emphasizing the atemporal-ity of unconscious processes: The unconscious ignores time, and he suggested that the origin of the representation of time could be found in the discontinuous relation the preconscious-conscious system maintained with the external world, the time dimension then being associated with acts of consciousness. He related the representation of time to the representation of space, in that space could replace time in unconscious processes. Finally, pathology shows how temporal progression is ignored, a characteristic which is also seen in fantasy, where past, present, and future are united in one representation, and in the transference neurosis, which is based on the anachrony of affect.

The atemporality of unconscious processes is present in Freud's earliest writings. In Manuscript M (1950a [1892–99]), James Strachey refers to a sentence in which Freud points out that the chronological information ignored in fantasy is dependent on the conscious system. But it is in *The Interpretation of Dreams* (1900a) that the indestructibility of unconscious processes is proposed, along with its corollary—the impossibility of recognizing the passage of time that would bring about the end of something; its belonging to the past; and eventually its forgetting. In a note added in 1907 to *The Psychopathology of Everyday Life* (1901b), concerning the indestructibility of memory traces, Freud wrote that “the unconscious is completely atemporal.”

Freud continued to repeat the same ideas, devoting considerable space to it in his essay on the metapsychology of the unconscious. “The processes of the system *Ucs.* are *timeless*; i.e. they are not ordered temporally, are not altered by the passage of time; they have no reference to time at all. Reference to time is bound up, once again, with the work of the system *Cs.*” (1915e, p. 187). In the November 8, 1911, session of the Minutes of the Vienna Psychoanalytic Society (Nunberg and Federn, 1962–75), Stekel and Meinhold were rapporteurs for the topic under discussion, “the supposed timelessness of the unconscious,” (Vol. 3, pp. 299–310) and during the discussion there arose a number of difficulties concerning the definition of time. In his conclusion Freud pointed out five arguments in favor of the atemporality of unconscious processes: the incorrect temporal orientation of dreams; the fact that condensation is possible; the lack of effects of temporal transition; the attachment to

objects; the characteristic tendency of neuroses to become fixed. He concludes: “If the philosophers maintain that the concepts of time and space are the necessary forms of our thinking, forethought tells us that the individual masters the world by means of two systems, one of which functions only in terms of time and the other only in terms of space” (p. 308).

While the processes of the unconscious are atemporal, Freud continued to remind us of the importance of the temporal factor as an element of reality. This is true of the process of maturation, which is the central element of the theory of libidinal states, but which also distinguishes normal from pathological mourning. (Time appears to be inevitable, to the extent that it seems endowed with intrinsic action while it is, in fact, the duration necessary to establish a process, work of some kind.) Conversely, time as experienced, the feeling of time, is shown to be relatively independent of the objective reality of the time shown on clocks and watches. We see this in the painful acceleration of duration constituted by the feeling of the ephemeral (1916a [1915]), but also, and in reverse, in the interminable extension of the boredom or impatience of the child who wants to “grow up,” that is, who wants to abolish the time that separates him from the age of his parents. Passion and the illumination or rush of the drug addict reduce duration to a point, the instant when the alpha and the omega meet.

Freud believed that the temporal dimension is accessible to us only as a function of acts of consciousness. Because these acts are not continuous but, like the “mystic writing pad,” depend on the innervation of the cathexes directed from the interior by rapid, periodic bursts into the preconscious-conscious system, this perception of time is also discontinuous. “I assumed,” Freud wrote, “I further had a suspicion that this discontinuous method of functioning of the system *Pcpt.-Cs.* lies at the bottom of the origin of the concept of time” (1925a, p. 231). Although time is ignored by unconscious processes, this does not mean it can't be represented in unconscious formations, which translate it as they see fit. This corresponds to what could be called “psychic temporality.”

After Freud other authors returned to the question of time in analysis and in psychopathology. Piera Aulagnier has shown the importance of anticipation in the relation between mother and child and in the process by which a subject identifies with it, a process



that, as it turns out, the psychotic is unable to complete (1975), being condemned to repeat the same thing over and over again.

SOPHIE DE MIJOLLA-MELLOR

*See also:* Psychic temporality.

### **Bibliography**

Aulagnier, Piera. (1975). *La violence de l'interprétation. Du pictogramme à l'énoncé*. Paris: Presses Universitaires de France.

Freud, Sigmund. (1900a). The interpretation of dreams. *SE*, 4–5: 1–625.

———. (1915e). The unconscious. *SE*, 14: 159–204.

———. (1925a). A note upon the “mystic writing pad.” *SE*, 19: 225–232.

Nunberg, Hermann, and Federn, Ernst. (1962–75). *Minutes of the Vienna Psychoanalytic Society*. New York: International Universities Press.

### **Further Reading**

Loewald, Hans W. (1962). Superego and time. *International Journal of Psychoanalysis*, 43, 264–268.

## **TOMASI DI PALMA DI LAMPEDUSA-WOLFF STOMERSEE, ALESSANDRA (1895–1982)**

Alessandra Tomasi, an Italian psychoanalyst, was born in Nice in 1895 and died in Rome in 1982. She spent the first twenty years of her life in St. Petersburg, where her father, the Baltic Baron Wolff Stomersee, was a high dignitary at the czar's court. In 1917, at the start of the Russian revolution, she moved to Riga, then to Berlin. There, during the 1920s, she was analyzed by Felix Boehm and attended courses and seminars at the Berlin Institute; her supervised analysis was monitored by Max Eitingon and H. Liebermann. In 1927, during a brief stay in Vienna, she had the opportunity to “see” Freud. That same year she joined her Italian-born mother in London, where she was about to marry (this was her second marriage) the Italian ambassador to the court of S. Giacomo.

At the home of her father-in-law, she met his nephew, Giuseppe Tomasi, Duke of Palma and Prince of Lampedusa, the future author of *The Leopard*, who

became her husband in 1932. After their marriage she settled in Sicily. In 1934 she met Edoardo Weiss in Rome. They had corresponded with one another since 1929 and it was Weiss who sponsored her entry in the Italian Psychoanalytic Society. Through the society she became friends with Emilio Servadio, Nicola Perrotti, and Cesare Musatti.

Once her value as a teacher and trainer became recognized, she was asked, in 1946, to help with the reorganization of the SPI and, that same year, helped organize the historic First National Congress on Psychoanalysis, which marked the official resumption of psychoanalysis in Italy. At this time, and during the next national congress (Rome, 1950), she presented two important essays: *Sviluppi della diagnostica e tecnica psicoanalitica* and *L'Aggressività nelle perversioni*. She was president of the SPI from 1955 to 1959.

It was through her assistance, and hers alone, that Freud and psychoanalysis penetrated Sicily, where she initially encountered strong resistance from prejudice arising from the region's inherent conservatism. Of the first core group of people that formed around her, it was Francesco Corrao, following the departure of the princess for Rome in 1957, who assumed the psychoanalytic mantle and continued the work she had begun in Sicily.

In Rome she lived in a state of partial isolation, but was very active as a psychoanalyst, and increased her efforts to popularize the work of her husband, who became one of the most important writers on the Italian landscape following the posthumous publication of *The Leopard* in 1958. According to Michael David (1966), the work of Giuseppe Tomasi di Lampedusa contains the traces of an awareness of Freudian theories—easily understandable for a writer whose wife had devoted her life to psychoanalysis. For David the fact that “the Lampedusa apartment, and even their library, was filled with neurotic patients—to the point that the author preferred to take refuge among friends or in a café to write—gave rise to the husband's ambivalence concerning psychoanalysis.”

Alessandra di Lampedusa's most important articles include the following, all of which appeared in the *Rivista di psicoanalisi*: “Le componenti preedipiche dell'isteria di angoscia” (1956), “Necrofilia e istinto di morte” (1956), and “La spersonalizzazione” (1960). In one of her last seminars, she analyzed a case of lycanthropy, referring to the Kleinian notion of *projective*

*identification*, for which she coined the neologism, *identificatory introjection*.

ANNA MARIA ACCERBONI

See also: Italy.

### **Bibliography**

David, Michael. (1966). *La psicoanalisi nella cultura italiana*. Turin: Boringhieri.

Petacchi, Giancarlo. (1987). Vita di pionieri. In A. M. Accerboni (Ed.), *La cultura psicoanalitica* (p. 168–173). Pordenone: Studio Tesi.

Tomasi di Palma, Alessandra. (1960) La spersonalizzazione. *Rivista di psicoanalisi*, 6 (1), 5–10.

---

## **TOPIQUE**

A French Freudian review founded in 1969 by Piera Aulagnier, who directed it until her death in 1990, *Topique* is, as of 2005, co-directed by Sophie de Mijolla-Mellor and Jean-Paul Valabrega, who continue its work and pursue its objectives in the spirit that has animated this review since its beginnings.

*Topique* was born in 1969, the same year that saw the creation of the Quatrième Groupe O.P.L.F., following what was the third scission in the psychoanalytic movement in France. The founder of *Topique* played a central role in this scission as well as in establishing the principles of the new group presenting itself both as an alternative to the International Psychoanalytical Association (IPA) as well as to the Lacanian group. However, from the very beginning, the review emphasized that *Topique* would belong to no particular school nor be tied to any group. Its goal was exclusively to participate in the advancement of psychoanalysis, with an intention of being open, both towards psychoanalysis itself and other disciplines too, notably psychiatry.

The review has been published successively by the Presses Universitaires de France (from 1969 to 1974, 12 numbers), Desclée de Brouwer (L'Épi; from 1974 to 1987, 28 numbers), Dunod (from 1987 to 1996, 22 numbers) and by L'Esprit du Temps (since 1996), three times a year.

*Topique* is independent, and is not the official organ of the Quatrième Groupe; however it is close to it, because its founder belonged to it, as well as those who

continue to edit the review. The first numbers had published the “Principles and Modalities of Functioning” (of the Quatrième Groupe), and the following issues took cognizance of its organizational modifications, as well as printing texts from its scientific conferences.

As *Topique* has been developing for more than thirty years, a retrospective view seems in order, involving at once a historical approach to the development of psychoanalysis in France, as well as a consideration of issues that were of special interest to the review. Especially noteworthy is the attention *Topique* has paid to the theory and technique of psychoanalysis in many texts, particularly in its early years—when it was anxious to construct an original perspective both regarding Lacanism and the norms of the IPA. However, *Topique* has always been a review of confrontation between different theoretical currents and their practitioners, publishing authors belonging to diverse psychoanalytical societies. Additionally, works representing psychoanalytical groups have always been welcome; as well as research centered on the practice of analysis, its clinical experiences and impasses; and challenges that psychosis continues to pose for Freudian metapsychology, in spite of the advances in current research and the new conceptual tools available because of it.

Finally, there have been special numbers involving psychoanalytical perspectives on cultural and social issues, with contributions from specialists from other domains, as well as psychoanalysts, who were interested in confronting psychoanalysis as a heuristic method. This was the case with the juridical domain in Number 52 (“To Have the Right” [Avoir droit], with art in Number 53 (“Powers of the Image” [Pouvoirs de l’Image]), anthropology in Number 43 (“Birth” [La naissance]), or Number 50 (“Twins and the Double” [Les jumeaux et le double]).

This diversity does not constitute a diversion in rapport to the central purpose, which remains linked to clinical practice and the theoretical elaboration rising out of it; it aims instead to restore to psychoanalysis the place Freud provided for it from the beginning, that is to say not that of a simple therapeutic process, but also as an adventure in human thought.

SOPHIE DE MIJOLLA-MELLOR

See also: Aulagnier-Spairani, Piera; Quatrième Groupe O. P. L. F., Fourth group; France.

### Bibliography

Valabrega, Jean-Paul. (1999). Trente an après...Entretien avec Sophie de Mijolla-Mellor. *Topique*, 69.

---

## TOPOGRAPHICAL POINT OF VIEW

Like the economic and the dynamic points of view, the topographical point of view is one of the three main dimensions of Freud's metapsychology. It introduced the idea that the mental apparatus was composed of different areas of the mind, different "territories" governed by different processes.

The idea of a mental topography was present in Freud's thought as early as the "Project for a Scientific Psychology" of 1895 (1950c), where it arose as a direct consequence of his conception of the history and successive stages of construction of the psychical apparatus.

In Freud's first topographical approach, three mental regions were distinguished: the conscious, the location of ideas that had direct access to consciousness; the preconscious, the location of material susceptible of becoming conscious fairly easily; and the unconscious, the location of whatever had been repressed from consciousness and was thus inaccessible to it. This initial spatial organization of the mind, known as the first topography, later proved inadequate for dealing with the clinical view of pathological narcissism, for it failed to locate the ego or the internalization of values and principles acquired in the course of the individual's development.

Beginning with *Beyond the Pleasure Principle* (1920g) and especially in *The Ego and the Id* (1923b), Freud proposed a new topography of the mental personality and apparatus in terms of the id, the ego, and the superego. The unconscious per se could no longer be treated as a single location in the psyche, for there were in fact several unconscious realms, and of different kinds. From then on, the term *unconscious* was used only as a qualifier applicable to mental processes, irrespective of their topographical location. A portion of the ego and of the superego were thus said to be unconscious, while components of the id could not become conscious without being transformed into representations, their original forms remaining unconscious.

The second topography did not replace the first, however. Rather, it remained in a dialectical relationship with it, thus complicating the model as a whole.

Some French psychoanalysts have taken the view that the two topographies are not merely metapsychological constructs but also correspond to specific organizational modes of the psyche. Different ways of mental functioning could thus be described in terms of the first or second topography, and the metapsychological account remained closely bound up with clinical practice.

RENÉ ROUSSILLON

*See also:* Agency; Censorship; Consciousness; Ego; *Ego and the Id, The*; Excitation; Id; Metapsychology; Model; *New Introductory Lectures on Psychoanalysis*; Perception-Consciousness (Pcpt.-Cs.); Preconscious, the; Psychic apparatus; Regression; Structural theories; Superego; *The Unconscious*; Unconscious, the; Wish, hallucinatory satisfaction of a.

### Bibliography

- Freud, Sigmund. (1915d). Repression. *SE*, 14: 141–158.
- . (1920g). Beyond the pleasure principle. *SE*, 18: 1–64.
- . (1923b). The ego and the id. *SE*, 19: 1–66.
- . (1950c [1895]). Project for a scientific psychology. *SE*, 1: 281–387.
- Roussillon, René. (1995). La métapsychologie des processus et la transitionnalité. *Revue française de psychanalyse*, 59, 1351–1519.

### Further Reading

- Paniagua, Cecilio. (2001). The attraction of topographical technique. *International Journal of Psychoanalysis*, 82, 671–684.

---

## TOPOLOGY

*Topology* refers primarily to the branch of mathematics that rigorously treats questions of neighborhoods, limits, and continuity. Psychoanalysts have applied it to the study of unconscious structures.

In what have been called his two "topographies" (the first dating from 1900 and the second from 1923), Freud resorted to schemas to represent the various parts of the psychic apparatus and their interrelations. These schemas implicitly posited an equivalence between psychic and Euclidean space.

**FIGURE 1**

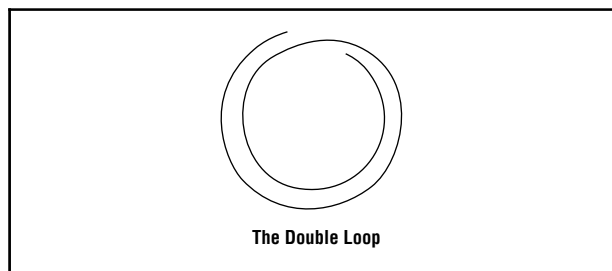

Early on, Jacques Lacan noted that the limitations of such a naive topology had restricted Freudian theory, not only in the description of the psychic apparatus (a description that in the end required an appeal to the economic point of view), but also in the specificity of clinical structures. The hypothesis that the unconscious is structured like a language, that is, in two dimensions, led Lacan to the topology of surfaces. The concept of foreclosure, for example, which he constructed on the basis of this topology, confirmed the heuristic value of his approach.

In his seminar “Identification” (1961–1962), Lacan unveiled a collection of topological objects—such as the torus, the Möbius strip, and the cross-cap—that served pedagogical aims. But already he saw them as more than just models. With the Borromean knot, introduced in 1973, he took the position that these objects were a real presentation of the subject and not just a representation. Below are several of Lacan’s topological objects.

### 1. The Cut and the Signifier

Far from being given a priori, every space is organized on the basis of cuts and can actually be considered as a cut in the space of a higher dimension. We are familiar with the subjective impact of this: The events of our lives only become history through the castration complex, which organizes our reality at the price of an imaginary cutting off of the penis. According to Freud, by introjecting a single trait of another, the subject identifies with the other (at the price of losing this person as a love object). In the single trait Lacan found the very structure of the signifier: A cut allows the lost object to fall away. He called this cut the “unary trait.”

The linguist Ferdinand de Saussure insisted on the fundamentally negative, purely differential character of the signifier. Lacan formalized this property in the double loop, or “interior eight,” in which the gap

created by the cut is closed after a second trip around a fictional axis. The difference of the signifier from itself is indicated by the difference between the two trips around the loop (Figure 1).

### 2. The Möbius Strip and Interpretation

If a signifier represents the subject for another signifier, then the subject would be supported by a surface whose edge would be a signifying cut. Note that the plane—the usual screen for the subject’s images, figures, and dreams, that is, plans—is a surface that does not meet these conditions. The double loop cannot be drawn on a plane without showing a cut. The same is true of a sphere, a simple representation of the universe.

The Möbius strip, on the other hand, can represent this cut and symbolize the subject of the unconscious. Since a Möbius strip only has one surface, it is possible to pass from one side to the other without crossing over any edge—an apt representation of the return of the repressed. The Möbius strip also has certain other peculiarities. A cut that runs one-third from the edge and parallel to the edge divides the strip into a two-sided strip linked to what remains of the original Möbius strip. But if this cut is made in the center, it does not divide the Möbius strip in two. Instead, the entire strip is transformed into a strip with two sides. This characteristic illustrates the equivalence between the Möbius strip (the subject) and the medial cut that transforms it, and also provides a model of how interpretation functions. Interpretation does not abolish the unconscious. On the contrary, it makes the unconscious real for the subject by its transformed appearance as another (an Other) surface (figure 2).

**FIGURE 2**

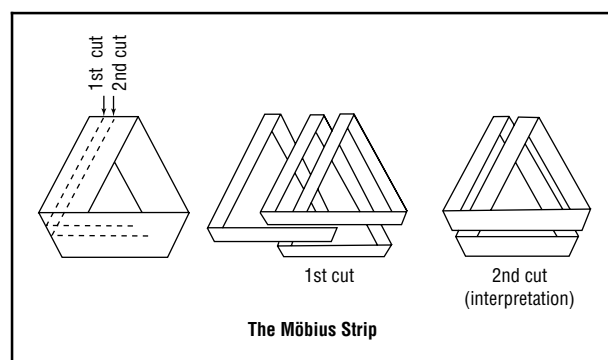

**FIGURE 3**

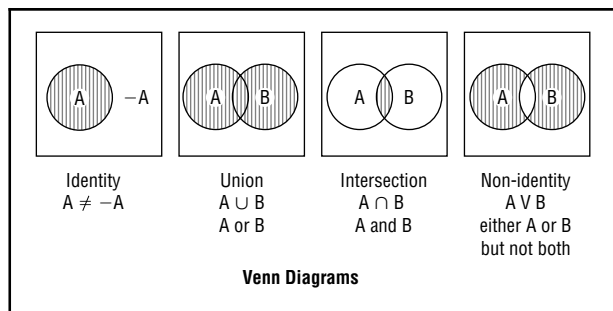

**FIGURE 4**

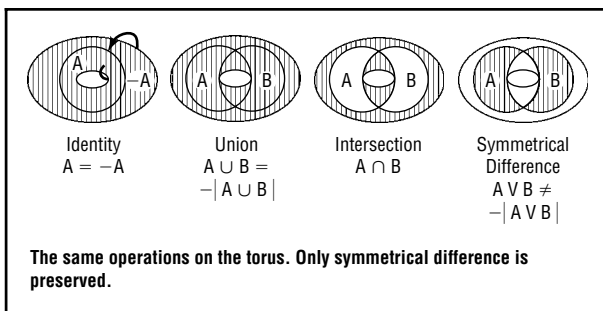

**FIGURE 5**

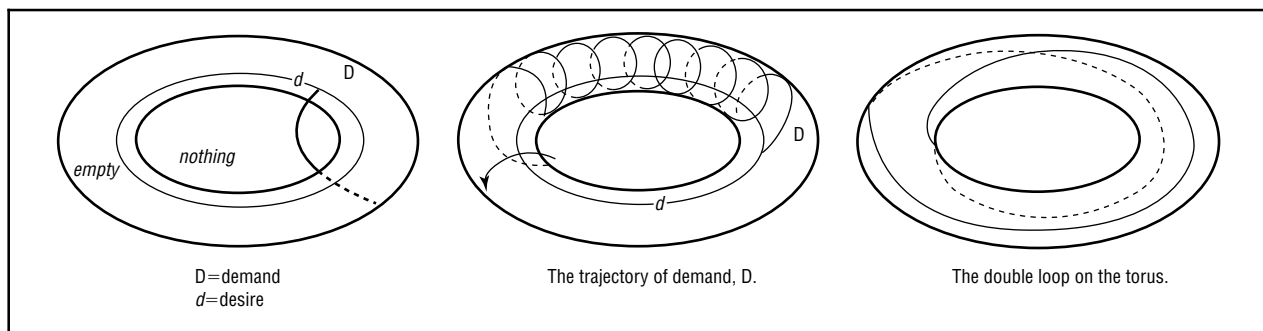

**FIGURE 6**

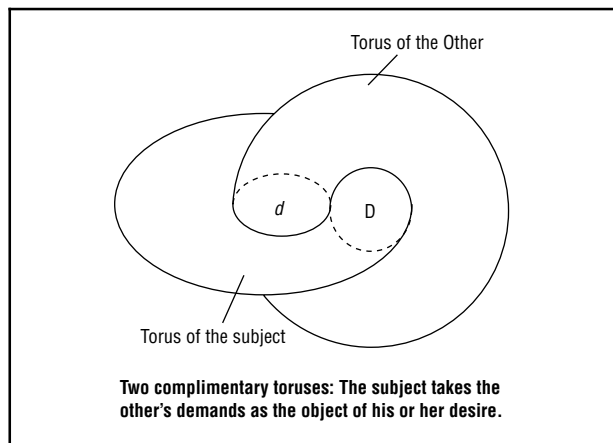

**3. The Torus**

Lacan made different uses of the torus. By drawing Venn diagrams, traditionally used to illustrate basic logical operations, on the surface of the torus, he demonstrated the extent to which our thinking depends upon the plane surface, and he also provided another possible basis for the logic of the unconscious (Figure 3).

By inscribing the same circles on the surface of the torus, Lacan revealed the logic of the unconscious discovered by Freud (Figure 4).

On the torus, only symmetrical difference is consistent. Thus we have a demonstration of how the signifier can be different from all other signifiers and also from itself.

Lacan also used the torus to represent the subject as the subject of demand. In this sense, the torus can be conceived as the surface created by the iteration of the trajectory of the subject's demand. This trajectory turns around two different empty spaces, one that is "internal,"  $D$ , the lack created in the real by speech, and one that is "central,"  $d$ , corresponding to the place of the elusive object of desire that the drive goes around before completing the loop (Figure 5).

For every torus, there is a complementary torus, and the empty spaces of the two are the inverse of each other. Lacan made this structure of complementary toruses the support of the neurotic illusion that makes the demand of the Other the object of subject's desire and, conversely, makes the desire of the Other the object of subject's demand. This structure also arises from the fact that on a torus, the signifying cut (the double loop) does not detach any fragment. Neurotic subjects, insofar as they give in to neurosis, insofar as they are "in the torus," are not organized around their

**FIGURE 7**

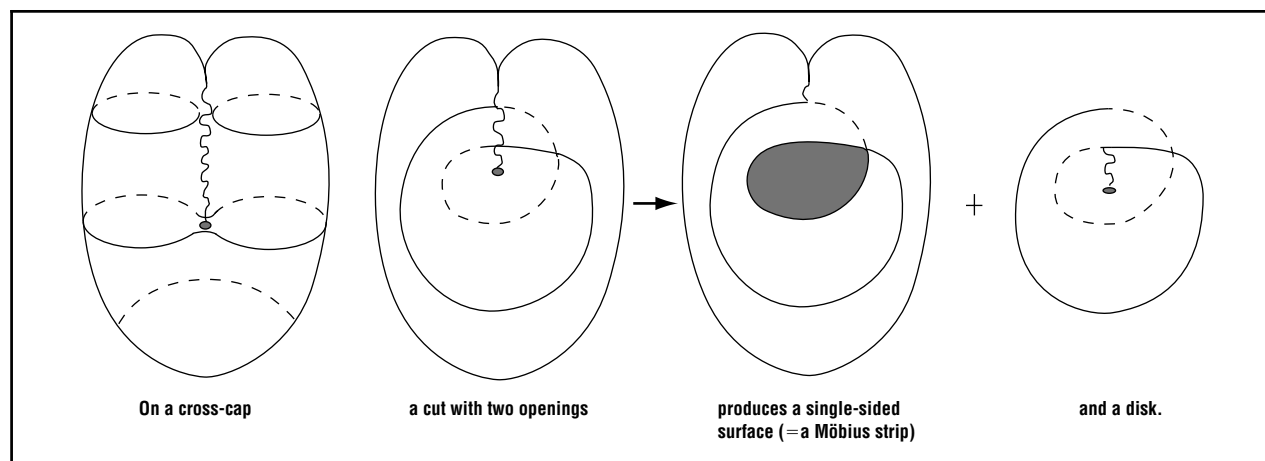

own castration, but instead excuse themselves by substituting the Other's demand for the object of their fantasy (figure 6).

**4. The Cross-Cap**

The cross-cap, or more precisely, the projective plane, can represent the subject of desire in relation to the lost object. A double loop drawn on its surface in effect divides this single-sided surface into two heterogeneous parts: a Möbius strip representing the subject and a disk representing object *a*, the cause of desire. The disk is centered on a point that is related to the irreducible singularity of this surface, which Lacan identified with the phallus. Unlike the representation of the subject produced on the torus, here a single cut, which symbolizes castration, produces both the subject and the object in its divisions (figure 7).

**5. The Borromean Knot**

Introduced by Lacan in 1973, the Borromean knot is the solution to a problem perceivable only in Lacanian theory but having extremely practical clinical applications. The problem is: How are the three registers posited as making up subjectivity—the real (R), the symbolic (S), and the imaginary (I)—held together?

Indeed, the symbolic (the signifier) and the imaginary (meaning) seem to have hardly anything in common—a fact demonstrated by the abundance and heterogeneity of languages. Moreover, the real, by definition, escapes the symbolic and the imaginary, since its resistance to them is precisely what makes it real.

**FIGURE 8**

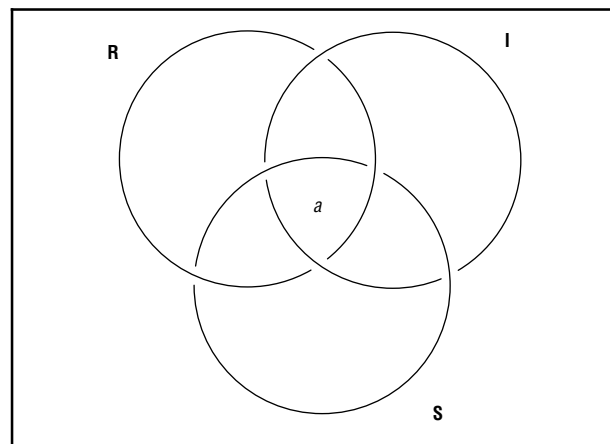

(This is why Lacan identified the real with the impossible.) In psychoanalysis, the real resists, and thus is distinct from, the imaginary defenses that the ego uses specifically to misrecognize the impossible and its consequences.

If each of the three registers R, S, and I that make up the Borromean knot is recognized to be toric in structure and the knot is constructed in three-dimensional space, it constitutes the perfect answer to the problem above, because it realizes a three-way joining of all three toruses, while none of them is actually linked to any other: If any one of them is cut, the other two are set free. Reciprocally, any knot that meets these conditions is called *Borromean*. Note that the subject is now defined by such a knot and not merely, as with the cross-cap, as the effect of a cut (figure 8).

FIGURE 9

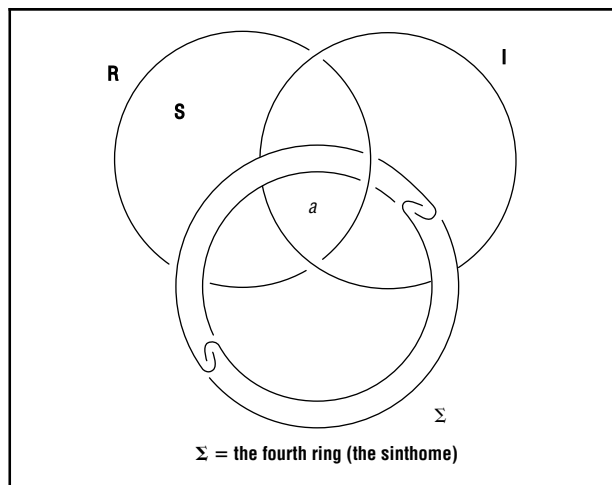

Unfortunately, this ideal solution, which could be considered normal (without symptoms), seems to lead to paranoia. Lacan considered this to be the result of failure to distinguish among the three registers, as if they were continuous, which indeed occurs in clinical work. Being identical, R, S, and I are only differentiated by means of a “complication,” a fourth ring that Lacan called the “sinthome.” By making a ring with the three others, the sinthome (symptom) differentiates the three others by assuring their knotting (figure 9).

In this arrangement, the sinthome has the function of determining one of the rings. If it is attached to the symbolic, it plays the role of the paternal metaphor and its corollary, a neurotic symptom.

Lacan also drew upon non-Borromean knots, generated by “slips,” or mistakes, in tying the knots. These allowed him to represent the status of subjects who are unattached to the imaginary or the real and who compensate for this with supplements (Lacan, 2001). In such cases the sinthome is maintained.

By using knots, Lacan was able to reveal his ongoing research without hiding its uncertainties. The value of the knots, which resist imaginary representation, is that they advance research that is not mere speculation and that they can grasp—at the cost of abandoning a grand synthesis—a few “bits of the real” (Lacan, 1976–1977, session of March 16, 1976). Even though he knew something about topology as practiced by mathematicians, Lacan advised his students “to use it stupidly” (Lacan, 1974–1975, session of December 17, 1974) as a remedy for our imaginary simpleminded-

ness. He also recommended manually working with the knots by cutting surfaces and tying knots. Finally, for Lacan, topology had not only heuristic value but also valuable implications for psychoanalytic practice.

BERNARD VANDERMERSCH

*See also:* Knot; L and R schemas; Seminar, Lacan’s; Signifier/signified; Structural theories; Symptom/sinthome; *Thalassa. A Theory of Genitality*; Unary trait.

### Bibliography

- Bourbaki, Nicolas. (1994). *Elements of the history of mathematics* (John Meldrum, Trans.). Berlin: Springer-Verlag.
- Darmon, Marc. (1990). *Essais sur la topologie Lacanienne*. Paris: Éditions de l’Association Freudienne Internationale.
- Lacan, Jacques. (1975). La troisième, intervention de J. Lacan, le 31 octobre 1974. *Lettres de l’École Freudienne*, 16, 178–203.
- . (1974–1975). Le séminaire, livre XXII, R.S.I. *Ornicar?* 2–5.
- . (1976–1977). Le séminaire XXIII, 1975–76: Le sinthome. *Ornicar?* 6–11.
- . (2001). Joyce: Le symptôme. In his *Autres écrits*. Paris: Seuil.
- Pont, Jean-Claude. (1974). *La topologie algébrique des origines à Poincaré*. Paris: Presses Universitaires de France.

## TOROK, MARIA (1925–1998)

A French psychoanalyst of Hungarian birth, Maria Torok was born on November 10, 1925, in Budapest and died in New York on March 25, 1998.

She trained as a psychologist at the Sorbonne in the early 1950s; there she met Nicolas Abraham, a philosopher interested in the phenomenology of Husserl and a psychoanalyst, and she became his companion. She was initially a psychological counselor in nursery schools when she went into analysis with Béla Grunberger and later with Margaret Clark-Williams, an American-born psychoanalyst. Torok went on to become an analyst and a member of the Société psychanalytique de Paris (Paris Psychoanalytic Society).

In Torok’s work together with Abraham as well as in their individual work, both were concerned with

differentiating the “shell” from the “kernel” of any theory, a concern that is articulated in their book *The Shell and the Kernel: Renewals in Psychoanalysis* (1978; trans. 1994): “[I]f Freud’s theories form the protective shell around his intuition, simultaneously concealing and revealing it, what of the actual kernel? For it is the kernel which, invisible but active, confers its meaning upon the whole construction. This kernel, the active principle of psychoanalytic theory, will not show through unless all the apparent contradictions have found their explanation of the unity I ascribe hypothetically to Freud’s intuition” (p. 82).

In her 1968 article “The Illness of Mourning and the Fantasy of the Exquisite Corpse,” Torok reexamined the problems of introjection and incorporation, as presented from the works of Sándor Ferenczi through those of Melanie Klein. She distinguished introjection, as a process that allows the ego to be enriched with the instinctual traits of the pleasure-object, from incorporation, a fantasmatic mechanism that positions the forbidden or prohibited object within the self in secret. “Installed in place of the lost object, the incorporated object continues to recall the fact that something else was lost: the desires quelled by repression” (p. 114). She developed a theory of the crypt and the phantom that haunts the subject and begins to speak in the subject’s place. The phenomenon of the phantom results not from the return of the repressed, but from the cryptic inclusion of an Other, in the face of which the illness of mourning and the work of mourning have not been able to take effect.

Torok thus took on the work of a patient and critical rereading of Freud, Ferenczi, and Klein, in an attempt to identify all that remained unanalyzed and “encrypted” in the systems of psychoanalysis. After Nicolas Abraham’s death in 1985, she continued this line of inquiry into psychoanalysis with Abraham’s nephew, Nicholas Rand.

JACQUES SÉDAT

See also: Abraham, Nicolas; Introjection.

### **Bibliography**

Abraham, Nicolas, and Torok, Maria. (1986). *The Wolf Man’s magic word: A cryptonymy* (Nicholas Rand, Trans.). Minneapolis: University of Minnesota Press. (Original work published 1976)

———. (1994). *The shell and the kernel: Renewals of psychoanalysis* (Nicholas T. Rand, Ed. and Trans.). Chicago: University of Chicago Press. (Original work published 1978)

———. (1995). *Questions for Freud: The secret history of psychoanalysis*. Cambridge, MA: Harvard University Press.

Torok, Maria. (1968). Maladie du deuil et fantasme du cadavre exquis. *Revue française de psychanalyse*, 32, 4. (Reprinted in translation as “The illness of mourning and the fantasy of the exquisite corpse,” in Abraham and Torok, *The shell and the kernel: Renewals of psychoanalysis*.)

---

## **TOSQUELLES, FRANÇOIS (1912–1994)**

François Tosquelles, a French physician, hospital psychiatrist, psychoanalyst, and founder of the movement for institutional psychotherapy, was born on August 12, 1912, in Reus (Catalonia, Spain) and died on September 24, 1994, in Granges-sur-Lot (France). He was reared in Reus in a progressive and culture-loving environment until he sat for his baccalaureate at the age of fifteen. He then enrolled in the medical school of Barcelona University, where he met Sándor Eiminder, an Austrian refugee fleeing Nazism, who became his psychoanalyst. As early as 1934 he was appointed to work as a physician in the Instituto Pere Mata and enjoyed the benefits of being psychoanalytically monitored by Werner Wolf, a German refugee who had settled in Barcelona.

In 1936 Spain elected the Popular Front and rapidly found itself facing down fascism. Tosquelles was appointed psychiatric head of the republican army. He implemented group techniques derived directly from psychoanalysis to treat psychological decompensation in soldiers, as Wilfrid Bion and John Rickman were to do in Great Britain during World War II.

Forced to flee Spain after the defeat of the republicans, he arrived in France and settled in Saint-Alban-sur-Limagnole (in the Lozère department) in 1940. As a result of his work with Lucien Bonnafé, André Chaurand, and many others during the period of Resistance, the Saint-Alban-sur-Limagnole psychiatric hospital became the crucible of a unique experiment based on the discoveries of psychoanalysis and aimed at treating the most seriously ill mental patients from a psychodynamic perspective. He worked with a large number of psychiatrists and psychoanalysts, the best known among them being Jean Oury, Hélène



Chaigneau, Jean Ayme, Horace Torruba, Roger Gentis, Philippe Rappard, and Yves Racine. Georges Daumézon and Philippe Koechlin later referred to this system as “institutional psychotherapy.” It greatly contributed to changing the face of French psychiatry by developing the system of “sector psychiatry” set up in the 1960s and 1970s. In this innovative practice of psychiatry, ongoing treatment made it possible to take the psychoanalytic concept of the transference relation into account. We find echoes of this system in Tosquelles’s book *Éducation et psychothérapie institutionnelle* (Education and institutional psychotherapy; 1984).

Tosquelles was very attached to a global conception of the human being. In his psychoanalytic practice he treated children and adults, individuals and groups, using the techniques of classical treatment and psychodrama. A polyglot possessing vast knowledge, he never ceased to establish links between the world of psychiatry and the discoveries of psychoanalysis, phenomenology, and anthropology. The quality of his presence for the other, his clinical intuition, his lively personality, and his indefatigable search to improve conditions for mental patients made him a unique figure in the history of psychoanalysis.

In the domain of psychoanalysis he was mainly responsible for introducing an in-depth approach to the study of psychopathology and the psychoses. Whether in the psychoanalytic study and comprehension of delusional manifestations and other elements in the behavior of schizophrenic and autistic patients or in reflection on the transference relations that come into play in their treatment, both for the patient and the therapist Tosquelles had the capacity to render complex psychoanalytic problems accessible and crystal-clear, irrespective of the status of his listeners.

Tosquelles instituted a movement of institutional psychotherapy that was furthered by Jean Oury, and continued by many psychiatrists and psychoanalysts. Moreover, he greatly contributed to demonstrating the importance of the nursing team. These contributions responded in part to the wish that Freud expressed at the Budapest Congress in 1918: “When this happens, institutions or out-patient clinics will be started, to which analytically-trained physicians will be appointed, so that men who would otherwise give way to drink, women for whom there is no choice between running wild or neurosis, may be made capable, by analysis, of resistance and of efficient work” (1919a [1918]).

A collection of papers, *Actualité de la psychothérapie institutionnelle* (The current state of institutional psychotherapy; 1994), includes Tosquelles’s last publication.

PIERRE DELION

See also: Fanon, Frantz; France.

### Bibliography

- Delion, Pierre (Ed.). (1994). *Actualité de la psychothérapie institutionnelle*. Vigneux, France: Éditions Matrice.
- Ellul, Jacques, Tosquelles, François, Corbin, Jean-François, et al. (1987). *La Genèse aujourd’hui*. Nantes, France: Arefpi.
- Freud, Sigmund. (1919a [1918]). Lines of advance in psycho-analytic therapy. *SE*, 17: 157–168.
- Tosquelles, François. (1967). *Structure et rééducation thérapeutique*. Paris: Éditions Universitaires.
- . (1984). *Éducation et psychothérapie institutionnelle*. Mantes, France: Hiatus.
- . (1986). *Le vécu de la fin du monde dans la folie*. Nantes, France: Arefpi.
- . (1992). *L’enseignement de la folie*. Toulouse, France: Privat.

---

## TOTEM AND TABOO

*Totem and Taboo* is Sigmund Freud’s first work on group psychology. The foundation of the work’s ideas first appears in 1911, in his correspondence with Sándor Ferenczi, through which it is possible to trace the development of Freud’s thought. Two topics appear in the letters: “tragic guilt” and the “libidinal origin of religion.” His competition with Carl Jung, who was writing the *Metamorphoses of the Soul and its Symbols* (1912), is mentioned, and their break in fact occurred while the book was being written.

The work presents a classic and sweeping analogy between two terms: on the one hand, savages, on the other, neurotics and children—us, in other words. The analogy unfolds in three parts, starting in the first essay where the resemblance between the two is related to the horror of incest that Freud identified in savages by analyzing totemic systems as laws of exogamy. The second essay interprets taboo as a manifestation of the ambivalence of emotions. Freud

postulates the primal existence of emotional currents, distinguishes between savages and the rest of us based on the intensity of emotion, and provides the first in-depth investigation of this conception of emotion. The third essay, cutting across similarities and differences, offers, among other things, the first detailed investigation of narcissism (animism). But there is more to the analogy, which Freud develops at the end of the third essay and in the fourth. He establishes the existence of the concepts he examines, the dynamic that governs them, as well as their bearing on his own work, on the following hypotheses: the existence of a primitive horde whose father is omnipotent; the murder of the father by the group of brothers, leading to the growth of the totemic clan, and the conditions for this possibility of thought.

The work is made difficult because of its complex construction, the manner in which Freud uses analogy, the extreme interpretative power of his analysis, the conceptual richness of the book—projection, ontogenesis of moral conscience, the reality-ego and pleasure-ego—and finally because of the “spiny hedge of literature and reference” included (letter to Ferenczi, May 13, 1913). This work also traces the Oedipus complex to a scientific myth that is found, in modified form, in the work of the majority of later psychoanalysts.

Although schematic and structural, *Totem and Taboo* was the basis for Freud’s work on group psychology. Like most of his work, it is more frequently reduced to a simple formula (the murder of the father by the horde) than studied or understood as a whole. The only valid criticism concerns the hypothesis of the phylogenetic transmission of precise memory traces. But the forms assumed by the primal horde and the totemic clan, as well as the foundational moment of rupture that they share, remain pertinent. The libidinal dynamics that constitute such groups were later elaborated in *Group Psychology and the Analysis of the Ego* (1921c), along with the status of the “poet” who invents the myth of origin.

MICHÈLE PORTE

*See also:* Act/action; Ambivalence; Animistic thought; Anthropology and psychoanalysis; Castration complex; Cultural transmission; Darwin, Darwinism and psychoanalysis; Ethics; Father complex; Gift; *Group Psychology and the Analysis of the Ego*; Heredity of acquired char-

acters; Identification; Incest; Magical thinking; Myth of origins; Mythology and psychoanalysis; Oedipus complex; Omnipotence of thoughts; Organic repression; Parricide/murder of the father; Phylogenesis; *Phylogenetic Fantasy, A: Overview of the Transference Neuroses*; Primitive; Primitive horde; Projection; Taboo; *Thalassa: A Theory of Genitality*; Totem/totemism; “Uncanny, The.”

### Source Citation

Freud, Sigmund (1912–13a), *Totem und Tabu. Einige Übereinstimmungen im Seelenleben der Wilden und der Neurotiker*, Leipzig-Vienna, Hugo Heller; *GW*, IX; appeared with the title “Über einige Übereinstimmungen im Seelenleben der Wilden und der Neurotiker” as a series of four essays in *Imago*; first essay: “Die Inzestscheu,” I, 1, Vienna, 1912, 17–33; second essay: “Das Tabu und die Ambivalenz der Gefühlsregungen,” I, 3, Vienna, 1912, 213–227, I, 4, 301–333; third essay: “Animismus, Magie und Allmacht der Gedanken,” II, 1, Vienna, 1913, 1–21; fourth essay: “Die infantile Widerkehr des Totemismus,” II, 4, Vienna, 1913, 357–408; Totem and taboo. *SE*, 13: 1–161.

### Bibliography

- Frazer, James G. (1910). *Totemism and exogamy*. New York.
- Freud, Sigmund. (1921c). Group psychology and the analysis of the ego. *SE*, 18: 65–143.
- Freud, Sigmund, and Ferenczi, Sandor. (1993–2000). *The correspondence of Sigmund Freud and Sándor Ferenczi* (Eds. Eva Brabant, Ernst Falzeder, and Patrizia Giampieri-Deutsch, Peter T. Hoffer, Trans.). Cambridge, MA: Belknap Press of Harvard University Press.
- Jung, Carl Gustav. (1911–12). Psychology of the unconscious: A study of the transformation and symbolism of the libido: A contribution to the history of the evolution of the thought. *Coll. Works*, Vol. 5. London: Routledge & Kegan Paul.
- Smith, William Robertson. (1889). *Lectures on the religion of the Semites*. New York: Schocken Books, 1972.

### Further Reading

- Mead, Margaret. (1963). Totem and taboo reconsidered with respect. *Bulletin of the Menninger Clinic*, 27, 185–199.
- Muensterberger, Warren. (Ed.) (1969). *Man and his culture: Psychoanalytic anthropology after Totem and Taboo*. London: Rapp and Whiting.
- Whiting, J. W. M. (1960). Totem and taboo—A re-evaluation. *Science and Psychoanalysis*, 3, 150–154.

## TOTEM/TOTEMISM

The word *totem* is derived from the Ojibwa language of North America, where it refers to kinship relations between siblings and the exogamous clan. In the nineteenth century, British anthropologists suggested that totemism, characterized by the existence of a fetish, exogamy, and matrilineal descent, was the fundamental institution of primitive societies and the essential basis of their beliefs, as distinct from the religious and scientific thought of western culture. This universalizing, comparative, and evolutionist attitude reached its apogee in James G. Frazer. It disappeared for methodological reasons. Ethnologists abandoned universalism to conduct local research, emphasizing the differences between cultures.

In Freud's work the word *totem* appears in a supplement (1912a), prepared for the Weimar Congress, September 21 and 22, 1911, describing his analysis of Justice Schreber's book (1911). After working for four months on *Totem and Taboo* (1912–13a), Freud announced his intentions as follows: "The assumption underlying these trials [proving the authenticity of children's lineage from a clan's totem] leads us deep into the *totemic* habits of thought of primitive peoples. The totem . . . spares the members of the tribe as being its own children, just as it itself is honoured by them as being their ancestor and is spared by them. We have here arrived at the considerations of matters which, as it seems to me, may make it possible to arrive at a psycho-analytic explanation of the origins of religion" (1911c, p. 81).

*Totem and Taboo* advanced the thesis that Freud developed in all his writing on group psychology, through *Moses and Monotheism* (1939a [1934–38])—and he indicates that he is aware of the criticism of the literature on totemism and undisturbed by it. Initially there was agreement between the two taboo prohibitions of totemism—killing the totem and marrying within the clan—were found to coincide with the two oedipal wishes—killing the father and marrying the mother. Psychoanalysis provided two other findings: childhood phobias showing the animal could function as a paternal substitute, and Ferenczi's observation of a child who identified with a cock (1913), which Freud associated with an "infantile return of totemism." He went on to describe the murder of the archaic father as the nucleus of totemism and point of departure for the formation of religion. The work of William Robertson Smith (1889) analyzing the "totemic meal" confirmed

the hypothesis: Once a year the totem animal was sacrificed and consumed by the members of the tribe. This was followed by a period of mourning and feasting. By adding the Darwinian assumption of primitive hordes, each under the domination of a single male who was powerful, violent, and jealous, the following scientific hypothesis or myth was set forth. The all-powerful and "absolutely narcissistic" father of the primal horde seized all the women and killed, subjugated, or chased away the sons. "One day, however, the sons came together and united to overwhelm, kill, and devour their father, who had been their enemy but also their ideal" (1925d [1924], p. 68). Afterward, none of the sons could take the place of the father. "Under the influence of failure and regret . . . they banded themselves into a clan of brothers by the help of the ordinances of totemism, which aimed at preventing a repetition of such a deed, and they jointly undertook to forego the possession of the women on whose account they had killed their father. . . . this was the origin of the exogamy which is so closely bound up with totemism. The totem-feast was the commemoration of the fearful dead from which sprang man's sense of guilt (or 'original sin') and which was the beginning at once of social organization, of religion, and of ethical restrictions. Now whether we suppose that such a possibility was a historical event or not, it brings the formation of religion within the circle of the father-complex and bases it upon the ambivalence which dominates that complex" (p. 60).

By assigning a collective prehistory to the Oedipus complex, while making an intrinsic connection between individual and collective psychology via the family, the totem hypothesis also bases the possibility of human thought on the murder of the father of the horde. The fulfillment of this act (i.e., murder of the father), studied throughout Freud's work on group psychology, is what leads to the formation of distinct psychic agencies—ego, ego ideal, and superego—along with the development of ambivalence and the appearance of the feeling of guilt, including unconscious guilt. The concept of the taboo depends on the thesis of totemism. Freud also attributed the susceptibility to hypnotism to the phylogenetic memory traces of the horde. Likewise, group psychology and religion are based on the premise of totemism. From this Freud deduced three paradigmatic forms and dynamics of group existence: the horde, matriarchy, and the totemic clan, and three paradigmatic forms of

religion that are related to them: the worship of mother-goddesses, of the son-hero, and of the father. The latter reveals the return of the repressed created by the murder of the father.

Modern ethnology has challenged the universality of Freud's claim and that of the Oedipus complex. The transmission of phylogenetic traces that are valid for the entire human species is problematic, even if Freud defends this idea with a form of Lamarckism. Nonetheless, Freud's arguments have continued to generate interest (Juillerat, 1991). In *Totem and Taboo* and *Moses and Monotheism*, Freud explicitly analyzed the libidinal forms and dynamics of western culture, with its monotheistic religions, its customs, its morality, its science, and its social and state institutions.

MICHÈLE PORTE

*See also:* Animistic thought; Double; Erotogenic masochism; Ethics; *Group Psychology and the Analysis of the Ego*; Group psychotherapies; Identification; Myth of origins; Mythology and psychoanalysis; Oral eroticism; Oral-sadistic stage; Orality; Parricide, murder of the father; Primitive; Primitive horde; Rite and ritual; Róheim, Géza; Substitute/substitutive formation; Taboo; *Totem and Taboo*.

### **Bibliography**

- Ferenczi, Sándor. (1913). Arpád: Un petit homme-coq [Ein kleiner Hahnemann]. *OC, Psychanalyse*, 2, 1913–1918. Paris: Payot.
- Freud, Sigmund. (1912–13a). Totem and taboo. *SE*, 13: 1–161.
- . (1925d [1924]). An autobiographical study. *SE*, 20: 1–74.
- Juillerat, Bernard. (1991). *Céipe chasseur: Une mythologie du sujet en Nouvelle-Guinée*. Paris: Presses Universitaires de France.
- Lévi-Strauss, Claude. (1964). *Totemism*. (Rodney Needham, Trans.) London: Merlin. (Original work published 1962)

## **TRAINING ANALYSIS**

The training analysis is the personal course of psychoanalytical treatment that every psychoanalyst must undergo with a certified analyst prior to, or in parallel with, his or her theoretical training, and before beginning to practice.

As late as 1909, Freud's answer to the hypothetical question "How can one become a psycho-analyst?" was still: "by studying one's own dreams" (1910a, p. 33). This was a shibboleth that he mentioned several times, but by the following year he widened the requirements: "no psycho-analyst goes further than his own complexes and internal resistances permit; and we consequently require that he shall begin his activity with a self-analysis and continually carry it deeper while he is making his observations on his patients. Anyone who fails to produce results in a self-analysis of this kind may at once give up any idea of being able to treat patients by analysis" (1910d, p. 145). Freud continued to use the term *Selbstanalyse* (self-analysis, or analysis of oneself) to include the procedure of being analyzed by a senior and more experienced person; Max Eitingon's analysis with Freud (1909–1909), conducted during evening strolls on the Ring, was the first instance of a training analysis. Freud later considered it "one of the many merits of the Zurich school of analysis that they have laid increased emphasis on this requirement, and have embodied it in the demand that everyone who wishes to carry out analyses on other people shall first himself undergo an analysis by someone with expert knowledge" (1912e, p. 116).

In 1918, with Freud's agreement, Hermann Nunberg proposed at the Fifth Congress of the International Psycho-Analytical Association that training analysis be made obligatory. Otto Rank and Viktor Tausk were opposed. The rule became official only in 1926. Rank and Sándor Ferenczi (1923/1925) made it clear, however, that "the correct didactic analysis is one that does not in the least differ from the curative treatment"; nor, in their view, should it be confined to physicians.

Ferenczi described the necessity for training analysis as "the second fundamental rule of psycho-analysis" (1928/1955, pp. 88–89). The adoption of the principle by the International Psychoanalytical Association (IPA) was the result, chiefly, of the efforts of Eitingon and of the initiative of the Berlin Institute, which had set up a training protocol as early as 1920. The training analysis was a cornerstone of that protocol, and Hanns Sachs was one of the first official *training analysts*.

Writing to Franz Alexander on May 13, 1928, Freud once again raised the bar: "One ought to demand guarantees from the candidates which are not necessary with patients, since regular analytic work has deleterious effects on one's psyche just as work with Roentgen

rays has on one's tissues; it needs to be countered by steady hard work" (Jones, p. 478). A few years later, at a time when the received wisdom was to extend analysis to the limit, Freud even suggested that "Every analyst should periodically—at intervals of five years or so—submit himself to analysis once more, without feeling ashamed of taking this step" (1937c, p. 249).

During the years when psychoanalysis was expanding, thanks both to the dispersal of émigrés in flight from Nazism and to the strengthening of the movement's institutions, training analysis became the subject of innumerable papers, reports, and debates, and the rules governing it were continually changing. A letter from Rudolph Loewenstein to Marie Bonaparte dated February 22, 1953, is eloquent on the prevailing norms: "Here [in New York], as in the American Association, there is a rule requiring training analysis to be conducted on the basis of at least four sessions per week, of between three-quarters of an hour and fifty-five minutes in length. Even the people in Chicago support this. The worst, though, are the Washington lot."

Regulations of this sort were at the root and core of a good many splits in the psychoanalytic movement, notably in France in 1953 and 1963, where Jacques Lacan's short sessions and his relationship with his analysands were challenged by the IPA authorities, who eventually barred him as a training analyst. Lacan retaliated by decreeing in the founding statement of his *École freudienne de Paris* that training analysis was the purest form of analysis, and by proposing (October 9, 1967) the institution of the system of induction of analysts that he called "*la passe*."

Critics of required training analyses variously underscore the antithesis between a professional project and the request for a personal analysis, the possibility of external rivalries corrupting the transference and/or counter-transference in such analyses, the hierarchical medical model implied by the title of *training analyst*, and even the danger of creating a "restricted transference zone" (Stein). There has been a tendency for the term *training analysis* to fade from use in training programs: the Paris Psychoanalytical Society, for example, under the influence of Sacha Nacht, prohibited any participation of a candidate's analyst in his or her training. The function of the training *analyst*, however, has shown remarkable staying power, and the international guidelines that the IPA's member societies are bound by in this connection are still the object of much debate and negotiation. Each group

strives by its own lights to settle on what Freud called "the training most suitable for an analyst" (1926e, p. 252), but the necessity of a preparatory personal analysis is universally acknowledged. Under what conditions, and with whom, are still open questions.

ALAIN DE MIJOLLA

*See also:* Association psychanalytique de France; Berliner Psychoanalytisches Institut; Berliner Psychoanalytische Poliklinik; Cure; *Development of Psycho-Analysis*; École freudienne de Paris; Eitingon, Max; Fourth analysis; France; International Psychoanalytic Association; Lay analysis; Psychoanalytic filiations; Pass, the; Psychoanalyst; Quatrième groupe (O.P.L.F.), Fourth group; Real, the (Lacan); "Recommendations to Physicians Practicing Psychoanalysis"; Société française de psychanalyse; Société psychanalytique de Paris and Institut de psychanalyse de Paris; Training of the psychoanalyst; United States.

### Bibliography

- Donnet, Jean-Luc. (1973). Le divan bien tempéré. *Nouvelle Revue de psychanalyse*, 8 (Autumn), 23–49.
- Ferenczi, Sándor. (1955). The elasticity of psycho-analytic technique. In *Final contributions to the problems and methods of psycho-analysis*. London: Hogarth and the Institute of Psycho-Analysis. (Original work published 1928)
- Ferenczi, Sándor, and Rank, Otto. (1925). *The development of psycho-analysis* (Caroline Weston, Trans.). New York and Washington: Nervous and Mental Disease Publishing. (Original work published 1923)
- Freud, Sigmund. (1910a [1909]). Five lectures on psycho-analysis. *SE*, 11: 7–55.
- . (1910d). The future prospects of psycho-analytic therapy. *SE*, 11: 139–151.
- . (1912e). Recommendations to physicians practising psycho-analysis. *SE*, 12: 109–120.
- . (1926e). The question of lay analysis. *SE*, 20: 177–250.
- . (1937c). Analysis terminable and interminable. *SE*, 23: 209–253.
- Girard, Claude. (1984). La part transmise. XLIIIe Congrès des psychanalystes de langues romanes. *Revue française de psychanalyse*, 48, 1.
- Jones, Ernest. (1957). *Sigmund Freud: Life and work*. London: Hogarth.
- Mannoni, Maud. (1970). *Le psychiatrie, son fou et la psychanalyse*. Paris: Seuil.

Stein, Conrad. (1972). Notes relatives au statut scientifique et au statut social de la psychanalyse. *Études freudiennes*, 5–6. (Original work published 1968)

## TRAINING OF THE PSYCHOANALYST

Psychoanalytic training is the process that enables a student to be recognized as a psychoanalyst by the psychoanalytic community and serves as a prelude to psychoanalytic practice. Many attempts have been made to define the optimum conditions for training since the early years of psychoanalysis. Following the creation of the Berlin Institute for Psychoanalysis in 1920, there came into being a number of organizations designed to provide training based initially on individual psychoanalysis.

At present there is no official degree or certification for psychoanalysts. Because of the excesses and pretenses that have inevitably accompanied the success of psychoanalysis, the issue often arises of the need to protect not only patients but also properly trained psychoanalysts, and ultimately psychoanalysis itself. However, the private institutions that represent psychoanalysis do not want the certification they provide to be part of any official legislation. There is a fundamental reason for this. Psychoanalytic training involves, first and foremost, personal experience of the analytic situation, and this experience is valid only if it is a subjective adventure freely undertaken. How could analysts in training reveal the most intimate aspects of their beings if the experience served as a means of obtaining a state-authorized degree or certificate?

Freud himself was aware of the problem early in his career. In a 1926 article (1926e), Freud argued against the idea of restricting analytic practice to medical doctors alone and pointed out the near impossibility of defining criteria for the “illegal practice” of psychoanalysis. His wish was that psychoanalysis be “neither permitted nor forbidden,” and thereby be free of government regulation. At the same time, he felt that organizations like the association he had created could regulate psychoanalysis and thereby resolve, to the extent possible, the problem of integrating psychoanalysis into society. Such an institution could establish methods of training and procedures for certification. In spite of various crises and criticisms, this model and its variants appears to have remained the most pertinent.

It is easier to describe the tripartite model that is generally a part of an analyst’s training than to summarize the contradictions that have arisen with the question of accreditation. There are three components to training, all of which are necessary. In the United States the analyst in training undertakes the three parts of training concomitantly. It is considered essential that a candidate undergo analytic treatment while conducting a supervised analysis so that problems that arise through the counter-transference can be analyzed.

The first component of training is the analysis of the candidate. In France, this requires a commitment to analysis prior to training and ensures that the analysis, when it occurs, calls into question the unconscious sources of the desire to be an analyst. If the candidate is not committed, or is incompletely committed, the candidate should draw the appropriate conclusion and withdraw from the field. Experience shows that this does not always happen, and in such cases the position assumed by the analyst is rarely compatible with the analyst’s performance. It is appropriate to refer such cases to a third party—an organization, for example—for adjudication. The personal experience of analysis is so important that it has been referred to as the *second fundamental rule*. This requirement follows from the demands made on the analyst in practice: evenly suspended attention, benevolent neutrality, the ability to analyze one’s own mental responses to the patient, identification and de-identification with the patient, and so on.

The conclusion of analysis and the criteria for success have been the subject of much spirited debate within the psychoanalytic community. Originally, the analysis was involved in only an aspect of the full potential of psychoanalysis: acknowledging the existence of the unconscious, which provides the subject with greater understanding and conviction. But with advances in the technique of analysis and the emergence of the concept of counter-transference, training analysis moved in the direction of the most complete analysis possible, with each of the major theoretical trends proposing a definition of a satisfactory conclusion in terms of its own criteria. The paradox is that defined criteria of a satisfactory conclusion engenders a normative reference that contradicts the very spirit of the analytic process. It is important to stress, therefore, that the analysis of the candidate has a greater chance of success if its didactic dimension is ignored,

if the ever-present real or imaginary requirements of the collective ideal are abandoned, and if the analysis finds its own *modus operandi*. The process requires only—but this is already asking quite a bit—that candidates, starting from an adequate intellectual base, engage in self-analysis and be able to identify and make use of the effects of counter-transference on themselves. As can be imagined, such a process of analysis exceeds the scope of training. Because of the risks associated with practice of the profession, the analyst should be prepared to undertake additional therapy when needed: one's own analysis being, by definition, open-ended.

The second component of training involves supervised analysis. The novice analyst speaks to a more experienced colleague on a regular basis about a current patient in analysis. This report can assume various forms and involve different kinds of comments and exchanges. What is essential is that the junior analyst talk about what takes place between his patient and himself in terms of transference and counter-transference. When he does so, he will necessarily reveal the unconscious counter-transference, which then can be pointed out and elaborated. One of the goals of supervision is to enable the beginning analyst to transcend identification with his own analyst and develop his own style.

The supervisory situation, typically involving two people, can also be conducted in small groups, in which case it resembles a seminar for clinical discussion. The controlled environment that supervision affords is so vital that all analysts should make use of it whenever problems occur in their practices. Supervision must therefore be considered a separate form of analysis, a process that occurs alongside therapy and serves as the basis for analyzing oneself while analyzing the patient.

The third component involves training in analytic knowledge and metapsychology. Naturally, it is desirable that the analyst be familiar with the key texts in psychoanalysis and be as well educated as possible. Study groups and seminars requiring the trainee's active participation and interaction with older colleagues will contribute to the trainee's education. Below are some additional points about education:

- Possessing knowledge is of limited value for practical competence. For the analyst, knowledge assumes value when a given concept, author, or clinical description arouses his interest, mobilizes his defenses, and encourages his identifications,

allowing him to access the truth at a given moment. And this process is entirely subjective. A theoretical overview intersects with the insights of self-analysis. Because psychoanalysis seeks knowledge of the unconscious, everyone must follow the road of Freudian discovery for himself.

- Studying Freud is a central part of training. This study is justified not only because Freud originated modern psychoanalysis and his depth and scope form an intellectual matrix for the discipline, but also because identification with the inventor of psychoanalysis shifts over time as a result of rejections and contradictions and multiple models. Critical study can weed out defensive adherence to a dogmatic and closed theoretical model. Finally, in view of the pluralism of post-Freudian thought, shared knowledge of Freud's work can be used to identify areas where differences, divisions, and revision occur. A century after Freud's discovery, an analyst's metapsychological grounding must involve some historical awareness, which is indispensable for orienting oneself within the immense body of psychoanalytic writing.
- Training in psychoanalysis also involves initiation into a range of fields opened up by the extension of psychoanalysis (child, psychosomatic, family, group psychoanalysis) and its application (care institutions, education). In all of these fields, what is important is that psychotherapeutic practices more or less follow the analytic model.
- In the ideal program of a psychoanalytic institute, Freud included the teaching of fields that he felt were essential for analytic thinking: anthropology, prehistory, mythology, history of religion, biology, linguistics, as well as others that have been added since, such as the arts. For the well-trained analyst, nothing human is foreign. In pursuit of this ideal the well-trained analyst will undergo continuous education.
- In a more immediately practical sense, the question of appropriate prior training has often been discussed. It is advisable that the analyst have at least a college education, have adequate experience of living and working, and have seen something of human suffering. In the early twenty-first century, the great majority of analysts came from the fields of medicine, especially psychiatry, and psychology, and indeed, knowledge of serious psychopathol-

ogy is indispensable in modern psychoanalytic practice. For these professionals, the encounter with their unconscious and access to metapsychological ways of thinking will still call their training into question, but it is not a bad thing if analytic training is primarily conceived as a form of undoing.

To ensure that a psychoanalytic body is responsible in certifying its members, it must explicitly define the principles on which training is based and the regulatory procedures to which trainers and trainees are subject. The most difficult aspect of this process is ensuring quality analysis of the psychoanalytic candidate while respecting the candidate's extrainstitutional space and time. For this reason and for purposes of maintaining confidentiality, every institutional discussion or decision concerning a candidate must explicitly exclude any interference by his analyst.

Interactions between applicants and institutions (such as offers of employment) reflect the options available and the views held by the various parties regarding the ethics of training and certification. Models range from selection prior to any commitment to analysis (as in the United States), a model that requires a highly organized course of study at an institution, all the way to certification after the fact, which makes candidate analysts fully responsible for the various aspects of their training. In intermediate models, supervised analysis serves as an introduction to the institution and thus as a preliminary form of certification. Logically, candidates' requests to move from couch to chair should coincide with affirmation of their desire to make the move. However, this connection cannot be made a requirement even though the institution requires it, because the affirmation ultimately lies with the subject.

In France, evaluation of a request for admission to a society generally takes place over the course of three meetings with three analysts assigned by the institution. In these meetings the candidate speaks about himself and his analysis. This is an awkward situation, for the candidate needs to transpose, in a conversation with an analyst who is also an examiner, what has until then been his intimate and private experience of the analytic situation. What the examining analysts seek in the candidate is not greater benefits from the analytic work but a display of the necessary distance that reflects the self-analytic ability required of an analyst.

In successful interviews, the candidate clarifies the truth of the dialogue of the meetings, and the examining analysts can consider whether the candidate is qualified for the work of analysis. From the personal nature of these meetings, it is easy to see that they require absolute confidentiality. The outcome of the meetings should be a collective response made on behalf of the institution. Ultimately, the most difficult problem is that of rejecting the candidate.

Further training and certification can assume very different forms. New analysts can be further evaluated in supervised analysis and seminars. Since an institution is defined as much by those it accepts as those it rejects, the problem of rejecting candidates remains. Flexible and controlled modulation of where to draw the line between admission and rejection makes for internal dynamism in scientific exchange, fertile tension between the individual and the group, as well as conflict between generations. Institutional certification acquires meaning only in relation to the duration of training, when supported by older colleagues, and in seeking the transmission of knowledge from one generation to the next.

JEAN-LUC DONNET

*See also:* American Psychoanalytic Association; Fourth Analysis Berliner Psychoanalytisches Institut; Berliner Psychoanalytische Poliklinik; *Development of Psychoanalysis*; Lehrinstitut der Wiener psychoanalytischen Vereinigung; New York Psychoanalytic Institute; Pass, the; Real, the (Lacan); "Recommendations to Physicians Practicing Psychoanalysis"; Splits in psychoanalysis; Supervised analysis (control case); Technique with adults, psychoanalytic; Technique with children, psychoanalytic; Training analysis.

### **Bibliography**

- Arfouilloux, Jean-Claude. (1989). La formation dans la S.F.P. et dans l'A.P.F.: Mlaise dans la culture analytique. *Revue internationale d'histoire de la psychanalyse*, 2, 343–368.
- Freud, Sigmund. (1926e). The question of lay analysis. *SE*, 20: 177–250.

### **Further Reading**

- Balint, Michael. (1954). Analytic training and training analysis. *International Journal of Psychoanalysis*, 35, 157–162.



Fenichel, Otto. (1982). Reflections on training and theory (1942). *International Review of Psychoanalysis*, 9, 155–162.

Freud, Anna. (1976). Remarks on problems of psychoanalytic training. *Writings (of Anna Freud)*, 8, 186–192.

Greenacre, Phyllis. (1966). Problems of training analysis. *Psychoanalytic Quarterly*, 35, 540–567.

Kernberg, Otto. (1996). Thirty methods to destroy the creativity of psychoanalytic candidates. *International Journal of Psychoanalysis*, 77, 1031–1040.

Knight, Robert P. (1945). Training in psychotherapy and psychoanalysis. *Bulletin of the Menninger Clinic*, 9, 54–59.

Wallerstein, Robert. (1998). *Lay analysis: Life inside the controversy*. Hillsdale, NJ: Analytic Press.

## TRANCE

According to Gilbert Rouget (1980), a *trance* is a “temporary state of altered consciousness that obeys a cultural model.” In the Middle Ages this term was applied to the agonies of death and the Passion of Christ. The word *trance* appeared in connection with the fakirs in a supplement to the first edition of the book *Neurhypnologie* by James Braid, the British doctor who popularized hypnotism. It was also used at the end of the nineteenth century to refer to the state of depersonalized mediums embodying the spirits of other people. From the perspective of physicians and psychologists of that era, exotic, spiritualistic, or Catholic trances could be explained in terms of provoked somnambulism, hypnosis, hysteria, or neurosis, notions that seemed to give a scientific explanation for these phenomena. Sigmund Freud associated himself with this tradition to some degree when he entitled one of his articles “A Seventeenth-Century Demonological Neurosis” (1923).

This perspective was reversed when ethnologists such as Alfred Métraux, Michel Leiris, or Roger Bastide began to use this term, which in their view was less ethnocentric, less psychologizing, or less psychiatric in tone than the words *hypnosis* or *hysteria*. *Trance* became the general term for experiences, rites, and beliefs relating to possession, shamanism, ecstasy, or divination observed in other cultures. From then on, magnetic somnambulism, hypnosis, and even psychoanalysis were seen as coming out of an Occidental trance culture. Thus, in *The Elementary Structures of Kinship* (1949/1969), Claude Lévi-Strauss described psychoanalysis as a “modern form of shamanism.”

While the question of a psychology or a psychoanalysis of the trance continues to be raised, it has been given away, in many contemporary studies, to that of the relationship between the individual and the cultural realms.

JACQUELINE CARROY

See also: Animal magnetism; Benign/malignant regression; Hypnosis; Jouissance (Lacan); Relaxation principle and neocatharsis.

## Bibliography

Freud, Sigmund. (1923d [1922]). A seventeenth-century demonological neurosis. *SE*, 19: 67–105.

Lapassade, Georges. (1990). *La Transe*. Paris: Presses Universitaires de France.

Lévi-Strauss, Claude. (1969). *The elementary structures of kinship* (James Harle Bell, John Richard von Sturmer, and Rodney Needham, Trans.) Boston: Beacon Press. (Original work published 1949)

Michaux, Didier (Ed.). (1995). *La transe et l'hypnose*. Paris: Imago.

Rouget, Gilbert. (1980). *La musique et la transe*. Paris: Gallimard.

## TRANSCULTURAL

For a long time the question of alterity (Julia Kristeva), and in particular cultural alterity, has been raised by psychoanalysis (Sigmund Freud, Sándor Ferenczi, Géza Roheim): psychic alterity and its avatars, working within the analytic framework, and the transformation of this alterity, which can be painful or difficult to come to terms with, into human creative potential. New ways of shedding light on this question are being found in the areas of both epistemology (Isabelle Stengers) and clinical work (adaptation of the analytic framework to non-Western populations, migrants, and so forth).

There are several modalities of integration of cultural representations into our clinical systems. Advances in anthropology have required practitioners to consider the two-way interactions between outside (culture) and inside (the individual's psychic functioning). Two different currents of thinking have emerged: those that hold that the therapeutic relationship is constituted from the outset by elements inferred to be

universal, and those that hold that the detour through the particular with its own specific coding, including cultural coding, is necessary. And yet, even among those who accept the presence of cultural presuppositions in the therapeutic relationship, two different epistemological positions can be noted, and regrettably, these have led to heated debates, more ideological than clinical, in many Western countries.

Some thinkers have adopted an essentially comparatist perspective: What are the invariant features that are found in our patients' culture and our own? This view leads to the construction of equivalencies and parallels between cultural elements of different worlds, but also between the cultural elements of one group and pathological behaviors of individuals belonging to other groups. This option was present in some of Freud's texts, such as *Totem and Taboo* (1912–1913a). On the clinical level, this choice leads to inserting the patient's language into certain mechanisms, and even becoming familiar with his or her cultural representations. But all of these elements are posited as a particular coloration of the clinical relationship, its nucleus (the effective part) being the same as what would be established in an intracultural situation. The approach here can be psychological (in France, H el ene Stork or Blandine Brill), psychiatric (this is especially the case in English-speaking countries, such as in the United States, with Arthur Kleinman), or, more rarely, psychoanalytic (the field called psychoanalytic anthropology).

Others, following Georges Devereux, have adopted a perspective based on complementarity and make requisite but not simultaneous use of psychoanalysis and anthropology. This complementary approach differs from the comparatist one in that cultural logics are explored as such and are used to support associations. The tool of anthropology makes it possible to establish and explore the framework of the relationship and to co-construct cultural meanings with the patient, to which individual meanings will be linked. This perspective, ethnopschoanalysis, is the most developed one in France. It is represented by the works of Tobie Nathan (1986), for the first generation, and those of Marie-Rose Moro (1994) for the second. In "L'Ethnopsychiatrie" (1978; Ethnopsychiatry), Devereux proposed a classification that recognizes three types of therapies that take into account the cultural dimension of mental disorders: "1. Intracultural, where the therapist and the patient belong to the same culture, but the therapist takes sociocultural dimensions into account....

2. Intercultural (or transcultural, as it was first defined), where although the patient and the therapist do not belong to the same culture, the therapist is well acquainted with the culture of the patient's ethnic group and uses this knowledge as a therapeutic tool. . . .

3. Metacultural: the therapist and the patient belong to two different cultures. The therapist is not familiar with the culture of the patient's ethnic group, but nevertheless has a thorough understanding of the concept of culture and uses it in establishing the diagnosis and carrying out the treatment."

In English-speaking countries, working from Devereux's classification, a distinction is made between cross-cultural psychiatry or psychology (intercultural) and transcultural psychiatry or psychology (transcultural or metacultural).

The term *transcultural* is used in an imprecise way to refer in the broadest sense to the inter-, intra-, and metacultural perspectives. In a more restricted and precise sense, it refers to the metacultural form, which presupposes a perfect understanding of the concept of culture. Thus, in clinical practice the issue of the transcultural takes on very different forms depending on country and on theories relating to intellectual history, and psychoanalysis in a given context.

MARIE-ROSE MORO

*See also:* Anthropology and psychoanalysis; *Basic Problems of Ethnopsychiatry*; Devereux, Georges; Ethnopsychiatry; *Totem and Taboo*.

### Bibliography

- Devereux, Georges. (1978). L'Ethnopsychiatrie. *Ethnopsychiatrica*, 1 (1), 7–13.
- Freud, Sigmund. (1912–13a). Totem and taboo. *SE*, 13: 1–161.
- Kleinman, Arthur. (1988). *Rethinking psychiatry: From cultural category to personal experience*. New York: Free Press.
- Moro, Marie-Rose. (1994). *Parents en exil. Psychopathologie et migration*. Paris: Presses Universitaires de France.

### Further Reading

- Chrzanowski, G. (1979). Editorial: Cultural and transcultural dimensions of Psychoanalysis. *Journal of the American Academy of Psychoanalysis*, 7, 331–334.

Davidson, L. (1980). Ethnic roots, transcultural methodology and psychoanalysis. *Journal of the American Academy of Psychoanalysis*, 8, 273–278.

Okano, K.-I. (1994). Shame and social phobia: A transcultural viewpoint. *Bulletin of the Menninger Clinic*, 58, 323–338.

Taketomo, Y. (1986). Toward the discovery of self: A transcultural perspective. *Journal of the American Academy of Psychoanalysis*, 14, 69–84.

## TRANSFERENCE

The term *transference* denotes a shift onto another person—usually the psychoanalyst—of feelings, desires, and modes of relating formerly organized or experienced in connection with persons in the subject's past whom the subject was highly invested in. *Transference* (*Übertragung*; literally, “carrying over”) was first used in *Studies on Hysteria* (Freud and Breuer, 1895d), and it gradually developed a more precise meaning over time with progress in the understanding of psychoanalytic treatment in its different dimensions. As of 2005, the term covers all the transference phenomena met with in analytic practice, more specifically, transference love, the transference relationship, transference neurosis, narcissistic transference, negative transference, and so on.

Transference involves transferring libidinal cathexis from one person to the form, personality, or characteristics of another. The quantity of libidinal energy deployed in such transfers varies and may be considerable, comparable in strength even to the original cathexes. There are two important points to note in this connection. First, what is mobilized here is libido; the other forms of instinctual energy evoked by Freud are not involved. Self-preservation, for example, plays no part in transference. Second, the withdrawal of libido from one object and the cathexis of another with it, as in states of mourning, is not a transference phenomenon. Transference implies maintenance of a particular relational form and fidelity to a past relationship that have been preserved in the unconscious.

The experience of psychoanalysis supports the conclusion that transference phenomena occur naturally in the course of ordinary life, especially with love relationships. Such “wild” transferences usually structure new relationships with outcomes very different from what happens during psychoanalytic treatment. As

Freud put it, “Psycho-analysis does not create [transference], but merely reveals it to consciousness and gains control of it in order to guide psychical processes towards the desired goal” (1910a [1909], p. 51). In its full meaning, transference is what is observed in the course of the treatment and what constitutes an essential precondition of the effectiveness of treatment. A subject incapable of any kind of transference is unsusceptible to treatment by analysis.

At first, in *Studies on Hysteria*, Freud viewed transference in terms of the hypnotic analyst-patient relationship, that is to say, solely in its relational, emotional, and amorous aspects. Freud considered establishing such a relationship to be a prerequisite of success with the cathartic method, just as establishing a hypnotic state is a prerequisite for hypnotic suggestion. For patients who put their trust in the analyst, Freud wrote, it is “almost inevitable that their personal relation to him will force itself, at least for a time, unduly into the foreground. It seems, indeed, as though an influence of this kind on the part of the doctor is a sine qua non to a solution of the problem” (1895d, p. 266). On several subsequent occasions Freud again related transference and suggestion, reiterating that transference was a precondition of suggestion. At the same time, he connected the intensity of the patient's relationship with the analyst with what he called a *mésalliance* (false connection) between a memory from the subject's past and the therapeutic situation: The content of a past wish arises “in the patient's consciousness unaccompanied by any memories of the surrounding circumstances which would have assigned it to a past time.” The wish is then linked to the analyst, with whom the patient is already legitimately connected. “As the result of this *mésalliance*—which I describe as a ‘false connection’—the same affect is produced which had forced the patient long before to repudiate this forbidden wish. Since I have discovered this, I have been able, whenever I have been similarly involved personally, to presume that a transference and a false connection have once more taken place” (p. 303).

Thus a transference is not only the patient's love of the analyst but also the transposition of an old relation onto him. Once Freud had reached this conclusion, he perceived that this second aspect of the transference took the form of a new illness, and that it could derive from very ancient relationships indeed. In “Fragment of an Analysis of a Case of Hysteria” (1905e [1901]),

for instance, he writes, “But the productive powers of the neurosis are by no means extinguished; they are occupied in the creation of a special class of mental structures, for the most part unconscious, to which the name of ‘*transferences*’ may be given” (p. 116).

Gradually the notion of *transference neurosis* came into relief for Freud: “Provided only that the patient shows compliance enough to respect the necessary conditions of the analysis, we regularly succeed in giving all the symptoms of the illness a new transference meaning and in replacing his ordinary neurosis by a ‘transference-neurosis’ of which he can be cured by the therapeutic work. The transference thus creates an intermediate region between illness and real life through which the transition from the one to the other is made. The new condition has taken over all the features of the illness; but it represents an artificial illness which is at every point accessible to our intervention” (1914g, p. 154). Repetition in the transference becomes the means whereby the patient remembers forgotten, unconscious mental attitudes: “The part of the patient’s emotional life which he can no longer recall to memory is re-experienced by him in his relation to the physician” (1910a [1909], p. 51).

Thus transference is the motor of the psychoanalytic cure, in more than one sense. For one, the transference introduces a new element into the patient’s mental situation, a “piece of real experience” (1914g, p. 154). For another, the transference is a necessary precondition of the patient’s acceptance of interpretations: “When is the moment for disclosing to [the patient] the hidden meaning of the ideas that occur to him? . . . Not until an effective transference has been established in [him], a proper *rapport* with him. It remains the first aim of the treatment to attach him to it and to the person of the doctor. To ensure this, nothing need be done but to give him time” (1913c, p. 139). Lastly, it is the energy of the transferred affects that supplies the force needed to remove resistances.

At the same time, transference is also responsible for resistance: “In analysis transference emerges as *the most powerful resistance* to the treatment, whereas outside analysis it must be regarded as the vehicle of cure and the condition of success” (1912b, p. 101). A kind of collusion may be struck up between resistance and transference if transference serves the aims of resistance or if a “distortion through transference” (p. 104) is used to mask a conflict. Thus analysis of the transference takes center stage, becoming the very heart, and a

defining part, of the treatment. “The decisive part of the work is achieved by creating in the patient’s relation to the doctor—in the ‘transference’—new editions of the old conflicts; in these the patient would like to behave in the same way as he did in the past, while we, by summoning every available mental force [in the patient], compel him to come to a fresh decision. Thus the transference becomes the battlefield on which all the mutually struggling forces should meet one another” (1916–1917a [1915–1917], p. 454).

Freud described two forms of transference, negative and positive. *Positive transference* covers all aspects of attachment to, and confidence in, the analyst; it is essential to successful treatment. *Negative transference* denotes hostile cathexes or excess cathexis, which may lead the patient to break off the therapeutic relationship.

The treatment, as it progresses, may be accompanied by such ancillary transference phenomena as *lateral transferences*. Lateral transferences are cathexes, parallel with the cathexis of the analyst, of some figure capable of focusing that portion of the subject’s libido and wishes that cannot be directly expressed to the analyst. Such transferences escape the sphere of transference proper, which is intermediate between the inner world and outside reality, and thus are inaccessible to analysis. But the relations they create may in reality be of great value in other ways to the patient.

The erotic dimension of the transference can constitute an obstacle to psychoanalytic cure in patients in whom disparate arguments connected by a nebulous logic prevents any shift in mental processes of the amorous cathexis of the analyst (1915a, pp. 166–167). Concerned by Ferenczi’s experimentation in this regard, Freud warned against offering any direct satisfaction to the patient; the danger was, he felt, that the analyst would find himself in the position of the pastor who attempted the death-bed conversion of an insurance salesman, only to leave with an insurance policy but no convert (p. 165).

PAUL DENIS

*See also:* Counter-transference; Displacement of the transference; Idealizing transference; Identification; Narcissistic transference; Negative therapeutic reaction; Negative transference; Psychotic transference; Resistance; Resolution of the transference; Therapeutic alliance; Transference/counter-transference (analytical psychology); Transference depression; Transference hatred;

Transference in children; Transference love; Transference neurosis; Transference relationship; Twinship transference/alter ego transference; Working-through.

### Bibliography

- Freud, Sigmund. (1905e [1901]). Fragment of an analysis of a case of hysteria. *SE*, 7: 1–122.
- . (1910a [1909]). Five lectures on psycho-analysis. *SE*, 11: 5–55.
- . (1912b). The dynamics of transference. *SE*, 12: 97–108.
- . (1913c). On beginning the treatment (further recommendations on the technique of psycho-analysis I). *SE*, 12: 121–144.
- . (1914g). Remembering, repeating, and working-through (further recommendations on the technique of psycho-analysis II). *SE*, 12: 145–156.
- . (1915a). Observations on transference love (further recommendations on the technique of psycho-analysis III). *SE*, 12: 157–171.
- . (1916–1917a [1915–1917]). Introductory lectures on psycho-analysis. *SE*, 15–16.
- Freud, Sigmund, and Breuer, Josef. (1895d). *Studies on hysteria*. *SE*, 2: 48–106.

### Further Reading

- Esman, Aaron H. (1990). *Essential papers on transference*. New York/London: New York University Press.
- Frank, George. (2000). Transference revisited/transference revisioned. *Psychoanalysis and Contemporary Thought*, 23, 459–478.

## TRANSFERENCE AND COUNTERTRANSFERENCE

Heinrich Racker (1910–1961) became a member of the Asociación Psicoanalítica Argentina (Psychoanalytic Association of Argentina) in 1947. The appearance of his book *Transference and Countertransference*, whose central theme is counter-transference, had considerable impact in Latin America, and also aroused interest and confirmation in other psychoanalytic centers of North America and Europe.

Racker argued that transference and counter-transference are the two components of a unity that

reciprocally give life to one another and create the interpersonal relationship in the analytic setting. The counter-transference encompasses the analyst's total response to the transferences of the patient and to his or her own transference reactions to the person of the analysand. It is a decisive factor for the understanding and interpretation of the patient's psychological processes.

In the establishment of the counter-transference, Racker distinguished between a “concordant identification,” which results from the analyst's identification with the analysand's ego, superego, and id, and a “complementary identification,” produced by the analyst's identification with the analysand's internal objects.

These identifications configure *transference-counter-transference neurosis*. There thus exists a *bipathy*. Within this bipathy, while negative or sexual transference disrupts the patient's collaboration in the analysis, the analyst's negative or sexual countertransference interferes with his or her comprehension of the analysand, and, consequently, his or her interpretive abilities. To successfully dissolve these resistances, the therapist must undertake constant self-analysis throughout the treatment of his or her patients. Paradoxically, counter-transference neurosis can play a positive role when the therapist uses it to understand the patient's neurosis. Racker showed how the analyst's affective position—dependent upon his or her archaic objects—appears as a response to that of the analysand, signaling psychological facts about it. From another viewpoint, the analyst also unconsciously communicates his or her affective contents to the patient. Racker particularly emphasized positive counter-transference, love, as a basic force for understanding that makes possible the development of a positive analytic process. He assigned three meanings to counter-transference, viewing its manifestations as a “danger,” an “instrument” for understanding and interpretation, and a “reliving that is simultaneously a new slice of life.”

FIDIAS CESIO

See also: Argentina; Empathy; Racker, Heinrich.

### Source Citation

Racker, Heinrich. (1960). *Estudios sobre técnica psicoanalítica*. Buenos Aires: Editorial Paidós; (1968). *Transference*

and countertransference. New York: International Universities Press.

### Bibliography

Cesio, Fidas. (1985). Heinrich Racker. *Revista de psicoanálisis de la Asociación psicoanalítica argentina*, 42, 2.

## TRANSFERENCE/COUNTER-TRANSFERENCE (ANALYTICAL PSYCHOLOGY)

*Transference* is the projection of unconscious contents. Jung's *Studies in Word Association* (1906) provided evidence for and referred to Freud's concept of transference, published the previous year. In 1912 Jung noted that the analysand's perception of the analyst's more mature personality forms an empathic bridge between his infantile relationship to reality and adult adaptation. He insisted that an analyst undergo analysis himself, and also saw the importance of analyzing the transference, which both hinders and facilitates psychological growth. By 1913 Jung had extended Freud's definition, saying transference was also the basis for normal human relatedness. After breaking with Freud, he analyzed his own projections, resolved them to achieve emotional, intellectual, and spiritual/moral autonomy, and concurrently set forth the elements of his opus. A survey of early work shows recognition of counter-transference, the reciprocal arousal of unconscious content in the analyst in response to patient projections. In 1929 he stated his view that the personality of the analyst contributes to analytic process, and that transformation is mutual. He also observed instances of unconscious identity between doctor and patient, giving it the anthropological term *participation mystique*; later it was recognized by psychoanalysts and called *projective identification*. So convinced was Jung that this unconscious reciprocal influence distorted all analytic discourse that he drew upon another projective system, alchemy, in *Psychology of the Transference* (1946) to demonstrate the ubiquity of transference and to identify stages in its evolution and resolution.

For some students this represents an incomprehensible departure from rational scientific method. To appreciate its logic one must first accept the role of metaphor in psychological theory building and, second, understand Jung's theory of archetypes and

his model of the psyche, which includes a personal and a collective unconscious. Although the concept of archetype has not been accepted by psychoanalysts, the idea has arisen independently in the fields of anthropology, linguistics, behavioral biology, and evolutionary psychiatry. Briefly, the capacity to perceive certain forms and processes is inherent, and these ancient, typical potentials are released, to acquire specific psychological content when, in the course of development, the individual encounters external reality. The collective unconscious contains all realizable human potential.

The analytic process itself is unconsciously directed by the archetype of individuation, the impulse to grow in psychological depth and complexity, and is an inherent property of the self, the archetype that embraces and comprises all other archetypes. Transference thereby acquires a teleological dimension, the symbolic intent and meaning of which is revealed and experienced as analysis unfolds; this is its prospective aspect, in contrast to the regressive projection of unconscious material from infantile or other past experience.

Jung recognized two universal, diametric archetypal urges in the individual psyche: to be separate, complete, and autonomous; and to be intimately bonded to the other, both coupled and enfolded in a group. These longings are primary motivating forces at the root of transference and resistance, constituting a fundamental paradox to be apprehended and resolved in individuation and analysis. Having this profound insight, he sought a metaphor to convey its universal, timeless, and impersonal meaning, to point analysands away from the average dependent/omnipotent transference fantasy. The mythology of medieval alchemy provided an unconscious projective system congenial enough to Western mentality to be accessible, but distant enough to reflect projections made in an analytic process that structures imaginative associations for the purpose of self examination. He chose a sixteenth-century treatise, the *Rosarium Philosophorum*, to reflect evolving transference/counter-transference fantasies in the analytic process.

All analytical psychologists view transference as a multileveled web of transecting relationships, interpersonal and intrapsychic, conscious and unconscious, occurring simultaneously within and between analyst and patient. Since the spiritual urge was regarded by Jung as an archetypal force equal to sexuality, his con-

cept of transference extends into transpersonal realms. For some analytical psychologists this is the major thrust of Jungian theory, whereas others seek to correct theoretical and methodological gaps, (for example, in the areas of child development and transference) through links to the work of psychoanalysts whose constructions are compatible with Jung's basic concepts (Kirsch, 1995). Modern psychoanalytic theories of self, projective identification, mutuality, and intersubjectivity all have antecedents in work Jung completed before 1946.

JEAN KIRSCH

*See also:* Alchemy (analytical psychology); Amplification (analytical psychology); Analytical psychology; Complex (analytical psychology); Counter-transference; Negative therapeutic reaction; Projection and "participation mystique" (analytical psychology); Transference.

### **Bibliography**

Jung, Carl Gustav. (1914a). On the importance of the unconscious in psychopathology, in *Coll. Works*, III. London: Routledge and Kegan Paul.

———. (1916). The structure of the unconscious, *Coll. Works*, VII. London: Routledge and Kegan Paul.

———. (1946). The psychology of the transference, *Coll. Works*, XVI. London: Routledge and Kegan Paul.

Kirsch, Jean (1995). Transference. In M. Stein (Ed.), *Jungian Analysis* (pp. 170–209). Chicago-La Salle: Open Court.

### **Further Reading**

Abend, Sander. (1989). Countertransference and psychoanalytic technique. *Psychoanalytic Quarterly*, 58, 374–395.

Gabbard, Glen. (1995). Countertransference: The emerging common ground. *International Journal of Psychoanalysis*, 76, 475–486.

Jacobs, Theodore. (1991). *The use of the self: Countertransference and communication in the analytic situation*. Madison, CT: International Universities Press.

———. (1999). Countertransference past and present: A review of the concept. *International Journal of Psychoanalysis*, 80, 575–594.

Loewald, Hans W. (1986). Transference-countertransference. *Journal of the American Psychoanalytic Association*, 34, 275–288.

Poland, Warren S. (1984). The analyst's words: Empathy and countertransference. *Psychoanalytic Quarterly*, 53, 421–424.

Searles, Harold. (1979). *Countertransference and related subjects*. New York: International Universities Press.

## **TRANSFERENCE DEPRESSION**

Transference itself reveals transference depression. Transference depression, which is a repetition of an infantile depression marked by narcissistic elements that is expressed within the transference relationship, usually after several years of analysis. Its symptoms are atypical of the depressive series. The difficulties raised by narcissism, on the other hand, concern the considerable demands made by the ideal ego, in addition to feelings of powerlessness and dissatisfaction.

Basing himself on Winnicott's work, André Green describes some of the more striking causes of this infantile depression in "The Dead Mother" (1983/1999). It is often a consequence of the mother brutally withdrawing emotional investment in the child because of a state of mourning before or after the child's birth, often caused by the death of another child or a close relative, or some other major narcissistic wound.

The most serious case involves the death of a very young child. This produces a profound alteration in the maternal imago. The latter, which is constituted in the child's psyche, "brutally transforms the internal object, a source of vitality, into a distant, atonal quasi-inanimate figure that profoundly impregnates the cathexes of its subjects and weighs upon the fate of their object-libidinal and narcissistic development." (Green, 1983) This narcissistic trauma, which the child experiences as a catastrophe, brings with it not only the loss of love but also the loss of meaning, since the child has no explanation or understanding of what has taken place.

The consequences of this catastrophe are decaathexis from the maternal object and the constitution within the psyche of a "dead" zone full of "holes" and, in addition, identification in the mirror with the "dead mother," which can lead the child to organize a pathology that aims to bring the mother back to life fantasmatically. Finally, the loss of meaning experienced by the child structures the early development of the ego's fantasmatic and intellectual capabilities; a development which does not take place in the context of freedom to imagine and create, but as compulsive thinking instead.

Sándor Ferenczi's ambivalent relationship to Sigmund Freud provides a particularly apt illustration of this notion. The "insatiable need for support" Ferenczi felt during his analysis with Freud can be considered as a manifestation of transference depression—the repetition of a childhood depression that has not been psychically worked through.

Transference depression, expressed through the emergence of an eroticized appeal addressed to the analyst, reveals a deprived child in a state of helpless distress, marked by a primary depression that has not been psychically worked through (Bokanowski, 1994). Behind the exacerbated demand for love and reparation deficiencies evident in cases transference-love, there are often developmental deficiencies and failures in the primary environment. The transference is thus eroticized as a defense against the fear of collapse, linked to the primary depression experienced by these patients in the very earliest stages of their development. In their interactions with the analyst they relive their despair and distress, as well as their deficiencies in primary symbolization. The erotic demand is thus an attempt to reconnect in the face of the anguish of the void and a deficit in the function of symbolizing.

JEAN-FRANÇOIS RABAIN

*See also:* Dead mother complex; Basic depression; Transference hatred.

### **Bibliography**

- Bokanowski, Thierry. (1994). *Ensuite survient un trouble*. In *Collectif: Ferenczi, patient et psychanalyste*. Paris: L'Harmattan.
- Green, André. (2001). The dead mother. In *Life narcissism, death narcissism* (Andrew Weller, Trans.). London: Free Association Books. (Original work published 1983)

---

## **TRANSFERENCE HATRED**

Transference hatred represents the negative pole of the transference relationship determined by the analytic situation. Negative affects are expressed by means of ambivalent impulses within the transference neurosis (negative transference) and destructive impulses more characteristic of borderline states and transference psychoses, notably in passionate psychoses.

In "The Dynamics of Transference" (1912b), Sigmund Freud proposed "to distinguish a 'positive' transference from a 'negative' one, the transference of affectionate feelings from that of hostile ones" (p. 105), the object in both cases being one and the same person, the doctor. Reminding readers that Eugen Bleuler was to be credited for the notion of "ambivalence" that characterizes these impulses, he gave the example of obsessional neurotics, in whom "an early separation of the 'pairs of opposites' seems to be characteristic of . . . instinctual life" (p. 107).

While positive transference is classically used "in order to" interpret, throughout treatment (distinguishing it from transference "to be interpreted," in the case of resistance; Jean-Luc Donnet), the idea, by contrast, is to "defuse" negative transference before it is possible subsequently to analyze it.

In fact, it is in borderline structures and transference psychoses that hateful and destructive impulses are the strongest, though they are sometimes masked by the apparent features of love. This is especially true with passionate transference. Feelings of love and psychic flooding can invade the transference situation and be expressed in ways that undermine the analytic framework. They attest to mnemonic traces that have not been successfully integrated into the psyche.

Passionate transferences express the violence of the unfulfilled need for love and of the need for reparation. Eroticization of the transference masks the impulses of hate linked to profound developmental deficiencies and failings in the early environment. These patients then make their analyst relive their despair and helplessness. They want to make the analyst feel the powerlessness and despair that they were unable to symbolize in infancy—that is, their deprivation of primary symbolization.

Sándor Ferenczi's ambivalent hatred toward Freud, his analyst, is an example of this phenomenon. Ferenczi's insatiable need for support during his analysis can be considered as the expression of a transference depression, itself linked to a childhood depression that had not been worked over, either by Ferenczi himself or by Freud; Ferenczi's *Clinical Diary* can be read as his eroticized complaint, the culmination of a negative and idealizing transference. According to Thierry Bokanowski's interpretation (1994), Ferenczi, through his innovations in technique, was demanding reparation, maternal in origin, from his analyst, for he had



managed to “freeze” in Freud the mother he was incapable of being. This is what borderline analysands sometimes do with their analyst: they “feed” him or her with the analysis in order to prolong it into an endless process.

After the second topography, in describing the negative therapeutic reaction, Freud emphasized the need for self-punishment, the severity of the superego, and the masochism of the ego. All the self-hatred in these subjects inhabited by what André Green described as a logic of despair (1990) reflects a compromise between the inextinguishable desire for revenge and concern for protecting the object from the hostile desires directed against it. Here, the conflict between love and hate is dominant. The desire for revenge is linked to the wounded narcissism of these subjects, who can no longer differentiate between the harm they want to inflict upon themselves and the harm they want to inflict on their object. From this perspective, “love is always uncertain, hate is always sure,” wrote Green. Thus these subjects arrange to perpetuate their chosen form of sadomasochistic relationship as long as possible.

However, it is possible for the intolerable nature of negative transference not to appear, remaining unconscious for both the patient and the analyst. The only symptoms: a quality of “gloominess” in the treatment (Cournut), disconnected thinking, decathexis or non-cathexis—that is, the “aphanisis” of the transference.

Other patients seek to “weld” their fragile narcissistic position back together again around an opposition to the object (Couvreur). In the transference and their complaints, they repeat early environmental deprivations. In them there is a fundamental hostility against the object, and the latter is thus loved in hate. Negative transference becomes a particular modality of the bond.

In “Hate in the Counter-Transference” (1949) Donald Winnicott showed the importance of the effects of this transference hatred. In the neurotic structures, the patient will tend to project his or her ambivalence onto the analyst and will believe that the analyst needs to negotiate his or her own ambivalence. By contrast, psychotic patients project their confusion onto the analyst. For them, love and hate coincide, and “should the analyst show love, he will surely at the same moment kill the patient” (p. 70). In certain cases, the patient seeks the analyst’s hatred. In Winnicott’s view, this hatred must be reached and experienced

bilaterally in treatment, “or else the patient cannot feel he can reach objective love” (p. 72).

JEAN-FRANÇOIS RABAIN

*See also:* Counter-transference; Negative therapeutic reaction; Transference.

### **Bibliography**

- Bokanowski, Thierry. (1994). Ensuite survient un trouble... Sándor Ferenczi, le transfert négatif et la dépression de transfertin. In Michèle Bertrand, et al., *Ferenczi, patient et psychanalyste* (pp. 9–52). Paris: L’Harmattan.
- Cournut, Jean. (2000). Le transfert négatif. Acceptions diverses plus ou moins pessimistes. *Revue française de psychanalyse*, 64, 2, 361–365.
- Couvreur, Catherine. (2000). Un mouvement qui est toujours le même, négatif. *Revue française de psychanalyse*, 64, 2, 367–381.
- Ferenczi, Sándor. (1988). *The clinical diary of Sándor Ferenczi. January–October 1932* (Judith Dupont, Ed.; Michael Balint and Nicola Zarday Jackson, Trans.). Cambridge, MA: Harvard University Press. (Original work published 1985 [1932])
- Freud, Sigmund. (1912b). The dynamics of transference. *SE*, 12: 97–108.
- Roussillon, René. (1991). *Paradoxes et Situations limites de la psychanalyse*. Paris: Presses Universitaires de France.
- Winnicott, Donald. (1949). Hate in the counter-transference. *International Journal of Psycho-Analysis*, 30, 69–74.

### **Further Reading**

- Gabbard, Glen O. (1991). Technical approaches to transference hate: Borderline patients. *International Journal of Psychoanalysis*, 72, 625–638.

---

## **TRANSFERENCE IN CHILDREN**

After about a century of psychoanalysis, there is no longer any doubt that children are capable of transference. On the other hand, the characteristics of transference and its themes of love and idealization are the very elements that can cause parents to have reservations about their child undergoing analysis, particularly—but not only—if they have not been sufficiently informed about this type of phenomena.

Moreover, this is what led Anna Freud to believe that the psychoanalysis of children was only possible in families that had already been genuinely won over by the ideas of psychoanalysis. Be this as it may, Donald Meltzer, in *The Psycho-Analytical Process*, went so far as to present child analysis as a much more pure situation than that of adult analysis, describing it in terms of a process divided into five successive phases, the first of which he called, precisely, “bringing together the elements of transference.”

From a historical point of view, it is interesting to note that the first analysis of a child was that of “Little Hans”—related in “Analysis of a Phobia in a Five-Year-Old Boy” (1909) and involving the child’s phobia to horses—and that Sigmund Freud conducted this analysis indirectly, based on the reports and notes of the boy’s father, himself one of Freud’s students. In other words, this analysis poses complex problems from the point of view of transference because it involved analysis of the child’s transference onto the image of his father, against the background of the more or less idealizing transference of the boy’s father himself onto Freud. This is something that is found, more or less, throughout the history of ideas relating to transference in children, particularly with regard to the question of whether or not children can form a joint transference onto their parents and onto their therapist.

It is thought that the child analyst’s main difficulty is not the absence of transference but instead the very opposite: seeing the development of a transference of unusual intensity, with archaic components that are sometimes so massive and so violent that they become difficult for the analyst to tolerate. This massive, archaic transference, mainly linked to the mechanism of projective identification described by Melanie Klein, is a splitting transference that often corresponds to a type of part-object relationship.

The controversy between Anna Freud and Klein must be recalled here, in those aspects that touch upon the issue of transference. One of the arguments that Anna Freud initially made against the possibility of transference in children was the fact of the child’s dependency in relation to his or her real objects, the parents. Klein countered this by arguing that the psychic structures were organized very early on, from the second semester of the child’s life, that the problems for which the child needed analysis were already linked to repetitions of earlier organizations, and that because of this, the child’s relationship with his or her real

objects was already, in itself, a mixture of real and imaginary objects, or, to put things differently, of objective and subjective elements. Whether or not the parents were alive, and whether or not they intervene in the child’s external reality, does not prevent the child from transferring onto the analyst the fantasmatic dimension of the relation to his or her internal parental objects.

The second, Kleinian point of view gradually became the dominant one and as of 2005 is commonly accepted among child analysts. Moreover, after 1926 Anna Freud herself moved perceptibly closer to Klein’s positions on this point. As Didier Houzel and Gilles Catoire wrote in an encyclopedia article on child analysis: “Repetition, in the relationship with the analyst, of these early psychic structures, that is, the relation of the self to its internal objects, is what constitutes the transference.”

This transference must be thought, understood, interpreted, and worked over with the child, but often, initially, it must only be tolerated and contained by the analyst, all the more so in that transference in children is often split—for example, between outside of treatment (the relationship with the parents) and inside treatment (the relationship with the analyst). If the analyst does not accept the extratransferential roles that the child wishes to make him or her play, and if, on the contrary, the analyst is willing to contain in him- or herself all the aspects of the transference (including its negative and destructive aspects), this splitting can then gradually be reduced.

By means of “bringing together the elements of the transference” and analysis of these transferential repetitions, the child’s ego is reinforced, anxieties are modified, and the major psychic functions are differentiated. This process is nevertheless long, often difficult, punctuated by the child’s attempts at avoidance, and lastly, capable of triggering a whole series of different counter-transferential impulses in the analyst. It can be noted that with children, even more so than with adults, the establishment of the transference can produce changes in symptoms that may make it seem, superficially, that the child has been cured. Care should be taken to warn parents about this, to prevent them from falling into the trap of interrupting their child’s analysis prematurely.

This attests to the importance of the therapeutic alliance with the parents, which is an integral part of

psychoanalytic technique with children, as a vouchsafe for the possibility of continuity in the therapeutic process. As with adults, the idea of the therapeutic alliance benefits from being differentiated from transference properly speaking, although this concept of therapeutic alliance, even in 2005, remains controversial.

But there is no transference without counter-transference, with children as with adults. The idea of counter-transference encompasses both unconscious elements of the analyst's psychic functioning that pose an obstacle to the course of the treatment, which must be kept from the patient, and alterations of the analyst's psyche under the influence of the child's projections, which, as is well known, are the basis of a certain very primitive, preverbal level of his or her communication. Only by means of working at self-analysis can the analyst become aware of these different phenomena and sort out these two very different aspects of his counter-transference.

At this cost, the counter-transference is an irreplaceable tool in child analysis (in fact, in analysis in general), and the entire Kleinian and post-Kleinian movement has strongly emphasized it. Indeed, with mute or psychotic children, or with very young children prior to language acquisition (*infans*), analysis of the counter-transference is sometimes the only means of giving meaning to the infraverbal material provided by the child, on the understanding that the dynamics of transference and countertransference are in fact indissociable and that in a way, they are one and the same.

The management of the counter-transference as a means of perceiving a part of the child's communication in fact requires some delicacy, owing, in part, to the closely interwoven relationship between what the child's projections induce in the analyst and what in turn is reactivated in the child by the analyst's counter-transference (which can be caught in the trap of a neutralizing projective counter-identification), all the more so in that it is possible that the child's projections may correspond to real aspects of the analyst's personality. In such cases, the analysis can only progress if the analyst truly gives herself the means to become aware of these aspects of her own personality and at the same time preserve herself from the child's projections, or rather, contain them and work them over.

Antonino Ferro, in *L'Enfant et le Psychanalyste: La question de la technique dans la psychanalyse des enfants* (1997; The child and the psychoanalyst: the question of

technique in child analysis), distinguishes among the three levels of listening among which the analyst must oscillate—the level of events, the level of fantasies, and the level inherent in the two-person field deployed within the analyst/analysand pair—and clearly shows how transference in children is an eminently dynamic process that “speaks” just as much about the present, against the background of the past, as it does about the past against the background of the present.

Finally, with regard to babies, their ability (or lack thereof) to transfer has for several years been at the center of a certain number of debates (Serge Lebovici, Bertrand Cramer, and others) about what has come to be known as joint parent/infant therapies, generally conducted by analysts. What has come out of this is that babies appear to be able to incite in their new relational partners interactive modalities that they have had the occasion to try out with their first objects of attachment, but whether or not it is possible, within this framework, really to talk about transference remains an entirely open question, even though these interactive repetitions can occur without significant intervals of time passing between the different experiences in question.

BERNARD GOLSE

*See also:* Child analysis; Counter-transference; Negative therapeutic reaction; *Psychoanalytical Treatment of Children*; Technique with children, psychoanalytic; Transference.

### **Bibliography**

- Ferro, Antonino. (1997). *L'Enfant et le Psychanalyste: La question de la technique dans la psychanalyse des enfants*. Ramonville-Saint-Agne, France: Érès.
- Freud, Sigmund. (1909). Analysis of a Phobia in a Five-Year-Old Boy. *SE*, 10: 1–149.
- Houzel, Didier, and Catoire, Gilles. (1986). La psychanalyse des enfants. *Encyclopédie médico-chirurgicale, Psychiatrie*. Paris: Encyclopédie médicale-chirurgicale. Fasc. 37-812-A-10.
- Meltzer, Donald. (1967). *The psycho-analytical process*. London: Heinemann Medical.

### **Further Reading**

- Furman, Erna. (2002). Transference and countertransference in child analysis. *Child Analysis*, 13, 113–188.

## TRANSFERENCE LOVE

The term *transference love* designates an emotional relationship, determined by the analytic situation, of which the manifest object is the analyst; the task of the analyst in this circumstance is to trace the relationship back, without either satisfying or smothering it, to its infantile roots.

Transference love is a defining feature of the psychoanalytic method. Psychoanalysis does not cure by love, but love and the analyst play a mediating role therein (Oppenheimer, Agnès, 1996). The set of inner problems generated by transference love, inasmuch as no direct satisfaction is forthcoming, eventually frees love from repression: The truly intermediary role of transference love thus makes love possible.

The transference follows the vicissitudes of love. When it is negative, hostile, or governed by repressed erotic impulses it constitutes resistance. According to Sigmund Freud, the “transference of friendly or affectionate feelings” which are “unobjectionable and admissible to consciousness” can contribute to a successful cure (1912b, p.105). Transference love allows the patient to become attached to the aims of the treatment as well as to the person of the analyst.

Even as resistance, transference love is thus a prerequisite to cure: it “represents an artificial illness which is at every point accessible to our intervention. It is a piece of real experience, but one which has been made possible by especially favorable conditions” (1914g, p. 154). One of the difficulties, or impossibilities, confronting the treatment is that some patients refuse to resign themselves to the fact that the material fulfillment of this surrogate love is not an option; such patients are “accessible only to ‘the logic of soup, with dumplings for arguments’” (1915a, p. 167). But can this still be considered love? It is clear that the manifest demand for love covers up latent considerations of another kind. The patient’s explicit demand for recognition also reflects a both demand for reparation, and shortcomings in their symbolizing capacity.

Where affectionate feelings are transformed into an erotic demand, Freud compares what happens to an outbreak of fire during a theatrical performance. The analyst’s interpretation is what then allows the patient to grasp that they are mistaken as to time and object.

In “Observations on Transference-Love” (1915a), Freud promoted an attitude with respect to the com-

plex phenomenon of transference love that would later be characterized by Michael Balint as “prudent.” Discussing the analyst’s difficulties when faced by transference love, and confining his remarks to the situation of a male analyst and a female patient, he called for prudence on the part of the doctor and warned, apropos of manifestations of transference love, “against any tendency to a counter-transference which may be present in his own mind” (p. 160).

A patient’s passionate attachment to the analyst should indeed never be treated as evidence of the physician’s personal irresistibility, but rather as an effect of the analytic situation itself. For Freud, transference was a *mésalliance*, a “false connection” (1895d, p. 303), and although the conduct of the cure required the analyst to maintain the transference love, they should nevertheless look upon it as “something unreal, as a situation which has to be gone through in the treatment and traced back to its unconscious origins” (1915a, p. 166). At the same time, despite this “unreality,” despite his emphasis on the inauthenticity, as it were, of the transference, Freud acknowledged that “We have no right to dispute that the state of being in love which makes its appearance in the course of analytic treatment has the character of a ‘genuine’ love.” In fact transference love was no different from any other kind of love, for “There is no such state [of being in love] which does not reproduce infantile prototypes” (p. 168). For Freud, it was this infantile aspect which gave love in general, and transference love in particular, “its compulsive character, verging as it does on the pathological” (p. 168).

What is repeated in transference love is frustration, a demand not heard, never answered, which leads the patient to reassume the position of a child with respect to the analyst. A love transference is usually capable of being analyzed and pressed into the service of the treatment, especially when it is moderate, as is most often the case, and when it is first manifested as defensive maneuvers.

Sometimes, however, the demand for love takes on a querulous character in passionate transferences: the patient’s grievance concerning this frustration becomes aggressive and exacting. An insistence on reparation emerges, stressful for the analytic setting and challenging to the analyst’s control over the counter-transference. The handling of the treatment is particularly difficult with patients who come close to erotomania or indeed sink into it. In such cases, as described by Freud, the

situation may have an incendiary character. Behind the exacerbated demand for love and reparation that is seen in passionate transferences lie developmental deficits and failures of the primary environment that have distorted the patient's self. The eroticization of the transference serves as a defense against a fear of disintegration, which in turn derives from the primary depression that such a patient will have experienced in the earliest stages of their development.

The analyst's primary position in the face of transference love is that of the interpreter. As Freud wrote, transference love must be traced back to its unconscious roots. For this reason abstinence must be the rule during the treatment. Considerations both technical and ethical prohibit the analyst from gratifying the solicitations of transference love. Like the physician bound by the Hippocratic oath, they must not draw personal profit from the analytic situation. But they must also never lose sight of the fact that the patient is suffering from a limited capacity to love for which infantile fixations are responsible. The analytic cure should make possible the restoration of a function that is of "inestimable importance" to the patient, one that they should not "dissipate in the treatment, but keep . . . ready for the time when, after [his or] her treatment, the demands of real life make themselves felt" (1915a, p. 169). Likewise, "If the patient's advances were returned it would be a great triumph for her"—and for the resistance—"but a complete defeat for the treatment. She would have succeeded . . . in acting out, in repeating in real life, what she ought only to have remembered, to have reproduced as psychical material." This "distressing episode would end in remorse and a great strengthening of her propensity to repression" (p. 166).

Clearly, the analysis of the counter-transference is necessary so as to prevent the analyst's personal feelings, complexes or inner resistances from hindering the progress of the treatment. The excitation provoked in the analyst by the patient's demands and transference projections, and notably the erotization of the transference, certainly put the analyst's superego to the test, but at a more fundamental level they challenge their relational skills and capacity for symbolization as well as mastery over their own desire for reparation.

Typically, acting-out by the practitioner, in response to the patient's transference love, signals a lack of professional maturity in dealing with the counter-transference anxiety aroused by the interpersonal

situation, as well as a failure to deal with personal narcissistic shortcomings or masochistic tendencies.

JEAN-FRANÇOIS RABAIN

*See also:* Abstinence/rule of abstinence; Counter-transference; Negative therapeutic reaction; Transference.

### Bibliography

- Freud, Sigmund, (1912b). The dynamics of transference. *SE*, 12: 97–108.
- . (1914g). Remembering, repeating and working-through (Further recommendations on the technique of psycho-analysis II). *SE*, 12: 145–156.
- . (1915a [1914]). Observations on transference love (Further recommendations on the technique of psycho-analysis III). *SE*, 12: 157–171.
- Freud, Sigmund, and Breuer, Josef. (1895d). Studies on hysteria. *SE*, 2.
- Oppenheimer, Agnès (1996). *Kohut et la psychologie du self*. Paris: Presses Universitaires de France.

---

## TRANSFERENCE NEUROSIS

Transference neurosis is a phenomenon of the analytic process in certain patients with adequately integrated egos and superegos in which the analyst's perception of the analyst becomes more and more recognizably entwined with core, organizing unconscious fantasy/memory complexes from childhood. These bear the stamp of oedipal conflict, its precursors and latency and adolescent sequelae. Freud first elaborated the concept in "Remembering, Repeating and Working Through," in 1914. There he stressed the analyst's aggressive pursuit of disease.

Three years later, he emphasized the insidious disease process itself, then elaborated on the power that the positive transference afforded the analyst to "divest" the patient's symptoms of libido. In *Beyond the Pleasure Principle* (1920a), he added that what was repeated in the transference neurosis was "some portion of infantile sexual life—of the Oedipus complex and its derivatives" (p. 18). That is, the transference neurosis was then seen to recapitulate an *infantile neurosis*. As he began to concern himself with impediments to cure, however, the concept dropped from his writings.

The concept appears in Freud in conjunction with the concepts of analysability and cure. Freud considered that only patients with transference neuroses were treatable by analysis. He designated the transference neurosis as an artificial symptomatic illness that expanded in the “playground” of the transference while the patient’s other symptoms and external difficulties disappeared. The transference neurosis constituted an “intermediate region between illness and real life” (1914g, p. 154). Cure then involved the annihilation by interpretation of the artificial illness.

Freud did not use the term after 1926. This silence, the increasing interest in character pathology on the part of contemporary analysts, and the greater reliance in some quarters on the structural theory have led to confusion, equivocation, and controversy. Manifest criteria that have been mistakenly offered as definitions such as the patient’s conscious focusing on his or her relationship to the analyst, or the cessation of all extra-transference difficulties, have either not been borne out by clinical data or raise other valid objections. Severed from its role as exclusive means to cure, however, in its modern definition, the transference neurosis continues to capture the essence of clinical psychoanalytic experience. The broader and more modern definition is the following: During the analytic process of certain patients with adequately integrated egos and superegos, a distillation occurs in which the analysand’s perception of the analyst becomes more and more recognizably entwined with core, organizing unconscious fantasy/memory complexes from childhood. These bear the stamp of oedipal conflict, its precursors and latency and adolescent sequelae. The analytic work takes on an intimacy prepared by the working through of narcissistic versions of these core conflicts so that the patient is able to experience a greater degree of libidinal involvement with the analyst. The autonomous willingness of the patient to reveal, explore, and work with the analyst also increases. The discovery of this crystallizing organization occurs simultaneously with the gradual disengagement of the object representation of the analyst from these same core fantasies.

GAIL S. REED

*See also:* Change; Counter-transference; Framework of the psychoanalytic treatment; Infantile, the; Negative therapeutic reaction; Negative, work of the; Psychoanalytical nosography; Time; Transference.

### Bibliography

- Freud, Sigmund. (1914g) Remembering, repeating and working-through (Further recommendations on the technique of psycho-analysis II). *SE*, 12, 145–156.
- . (1916–17a [1915–17]) Introductory lectures on psycho-analysis. Parts I and II. *SE*, 15–16.
- . (1920g). Beyond the pleasure principle. *SE*, 18: 1–64.
- . (1926e) The question of lay analysis. *SE*, 20: 177–250.
- Reed, Gail S. (1994) *Transference neurosis and psychoanalytic experience: Perspectives on contemporary clinical practice*. London and New Haven, CT: Yale University Press.

### Further Reading

- Blum, Harold P. (1971). On the conception and development of the transference neurosis. *Journal of the American Psychoanalytic Association*, 19, 41–53.
- Jacobs, Theodore J. (1987). Analytic secrets and the transference neurosis. *Psychoanalytical Inquiry*, 7, 485–510.
- Loewald, Hans W. (1971). The transference neurosis: Comments on the concept, phenomenon. *Journal of the American Psychoanalytic Association*, 19, 54–66.
- Reed, Gail S. (1994). *Transference neurosis and psychoanalytic experience: Perspectives on contemporary clinical practice*. New Haven, CT: Yale University Press.
- Renik, Owen. (1990). Concept of transference neurosis and psychoanalytic methodology. *International Journal of Psychoanalysis*, 71, 197–204.

---

## TRANSFERENCE OF CREATIVITY

The transference of creativity, whose defining example is Sigmund Freud’s transference onto Wilhelm Fliess, is a form of transference whose role is to accompany the fluctuations of creativity in the creator.

Initially implicit in Heinz Kohut’s work, this notion was explicitly mentioned by him from 1966 on. The correlative of the importance given to creativity, and a therapeutic factor or the effect of treatment that is not interpreted, it indicates a transformation of narcissism.

Starting with Freud’s self-analysis, Kohut stipulated in “Selected Problems of Self Psychological Theory” (1980) that Freud’s relationship with Fliess was not

transference in the classical sense—there was no dissolution through insight—but rather a transference of creativity that disappeared at the same time as the narcissistic need. Fliess was a function that filled a void and facilitated Freud’s creativity. During certain creative periods, creators need self-objects in one sector of the self or another, without this necessarily indicating weaknesses in the self. The creator’s narcissistic configurations are more fluid at certain times, and the other person makes possible regulation of self-esteem and confidence possible.

Transference of creativity, a form of narcissistic transference outside of treatment, brings into play all the notions that come out of Kohut’s theory.

AGNÈS OPPENHEIMER

See also: Fliess, Wilhelm; Kohut, Heinz.

### **Bibliography**

- Kohut, Heinz. (1955). Review of *Beethoven and His Nephew*. *Psychoanalytic Quarterly*, 24, 453–455.
- . (1955). Review of *The Haunting Melody. Psychoanalytic Experiences in Life and Music*. *Psychoanalytic Quarterly*, 24, 134–137.
- . (1957). Death in Venice by Mann: Disintegration of artistic sublimation. *Psychoanalytic Quarterly*, 26, 206–228.
- . (1957). Observations on the psychological functions of music. *Journal of the American Psychoanalytic Association*, 5, 389–407.
- . (1957). Review of *The Arrow and the Lyre. A Study of the Role of Love in the Works of Thomas Mann*. *Psychoanalytic Quarterly*, 26, 273–275.
- . (1966). Forms and Transformations of Narcissism. *Journal of the American Psychoanalytic Association*, 14, 243–272.
- . (1971) *The Analysis of the Self*. New York: International Universities Press.
- . (1980). Selected problems of self psychological theory. *The Search for the Self* (Vol. 4; pp. 489–523). New York: International Universities Press.

## **TRANSFERENCE RELATIONSHIP**

The term *transference relationship* designates those aspects of the patient-analyst relationship involving the patient’s previous object-relationships transposed

onto the analyst (that is, the transference). The transference relationship thus constitutes the heart of the analytic situation, encompassing all aspects of the relationship between the patient and the analyst: the analytic contract, the setting of the analysis, countertransference, and so on.

This notion was implicitly present as soon as transference was discovered, as early as Freud and Josef Breuer’s *Studies on Hysteria* (1895d). Anna O., plagued by the fantasy of giving birth to a child of Dr. Breuer’s, was entangled in a perfect instance of the transference relationship. The term itself, however, appeared very late in Freud’s work, in “Constructions in Analysis” (1937d): “Our experience has shown that the relation of transference, which becomes established towards the analyst, is particularly calculated to favor the return of these emotional connections” (p. 258).

This remark demonstrates that for Freud the transference was a melting pot into which the analysand’s earlier affective relations were drawn prior to being recast. Seen in this light, the transference relationship, determined first and foremost by transference love, has two aspects: first, a “piece of real experience” (1914g, p. 154), whose novelty is most important; and second, an element of repetition, for the transference also embodies the replaying of infantile sexual and affective relations. Sándor Ferenczi (1916) emphasized the link between the transference relationship and introjection: in the transference, the analyst is introjected by the patient as a new internal object.

The newness of the transference relationship is a significant factor in effecting change. The transference involves more than the patient’s reliving an earlier relationship. The analyst’s attitude and interpretations modify the patient’s attempts exactly to repeat the past in the transference, thus allowing something else to take place. In some respects, the analyst plays the part of a new object, an object anchored in reality. The gulf between this “real relationship” and the “false connection of the transference” helps the patient to perceive his own mental impulses.

What many authors have described as a “real relationship” with the analyst thus stands opposed to the transference relationship. Ralph Greenson, for example, wrote, “I intend to use the term ‘real’ to refer to the realistic *and* genuine relationship between analyst and patient—as opposed, that is, to unrealistic and inappropriate, albeit genuine, transference reactions”

(p. 217). “In adults,” Greenson added, “all relationships to people consist of a varying mixture of transference and reality. There is no transference reaction, no matter how fantastic, without a germ of truth, and there is no realistic relationship without some trace of a transference fantasy” (p. 219). So the real and transference relationships are somewhat interdependent. Similar considerations apply to the “therapeutic alliance” described by many authors, to Otto Fenichel’s “rational transference,” and to the “basic transference” evoked by Catherine Parat.

Elizabeth Zetzel’s notion of the “therapeutic alliance,” like Greenson’s “working alliance,” denotes a component of the analytic relationship, yet properly conceived, it should not be brought under the heading of the transference relationship, even though for many authors such an alliance is a necessary precondition of the development of the transference relationship. The transference relationship is predicated on the patient’s ego being reasonable. The patient must be capable of working with the analyst to conquer the neurosis and the negative aspects of the transference. From a different perspective, Richard Sterba (1940) based the therapeutic alliance on the patient’s identification with the analyst, thus giving it a fully transferenceal sense.

For Fenichel (1941), the transference relationship implies what he called a “rational,” positive transference, which brings inhibited drives into play with the aim of the transference relationship. Fenichel’s approach has much in common with Parat’s conception of basic transference. The transference relationship, for Parat, “corresponds to the patient’s cathexis of the person of the analyst, and is colored by feelings of trust. . . . This cathexis is founded on subjective elements which I have elsewhere described as projective, using the term ‘basic transference’ to designate a spontaneous, interhuman link with positive overtones which derives from the earliest attachments, as subsequently enriched by secondary experiences, as well as from objective elements perceived by the patient beginning with his first contacts with the analyst, be they gross or subtle. . . . The basic positive transference has a narcissistic libidinal origin” (1995). Parat stressed the kinship between such a transference cathexis and Freud’s “narcissistic object-choice,” thus more closely assimilating it to narcissistic transferences properly so called.

The capacity of the transference relationship to evolve is what makes it analyzable. In contrast to what occurs in everyday interpersonal relationships, where

transferences tend to jell into more or less stable compromises, in the transference relationship the attitude of the analyst, who does not respond in kind to the patient’s erotic solicitations but instead relates them to their oedipal prototypes, separately exposes the various avatars of the transference—paternal, maternal, fraternal, and so on, corresponding to different periods of the patient’s life. The analyst does not allow himself to be locked into one specific relational mode: he behaves at once as an object, drawing the patient’s cathexis toward him, and as an antiobject, by interpreting the patient’s transference onto him so that the transference image may unfold (Denis, 1988). To paraphrase Freud’s metaphor (1915a, p. 169), the practitioner comports himself like the mechanical rabbit in a greyhound coursing: it is continually moving out of reach, thus ensuring the continuation of the race; were a real rabbit thrown amid the dogs, it would immediately be devoured, and the race abandoned.

PAUL DENIS

*See also:* Counter-transference; Negative therapeutic reaction; Object relations theory; Relaxation psychotherapy; Transference; Transgression.

### **Bibliography**

- Denis, Paul. (1988). L’avenir d’une désillusion: Le contre-transfert, destin du transfert. *Revue française de psychanalyse*, 52 (4), 829–842.
- Fenichel, Otto. (1941). *Problems of psychoanalytic technique* (David Brunswick, Trans.). New York: Psychoanalytic Quarterly.
- Ferenczi, Sándor. (1916). Introjection and transference. In his *Contributions to Psycho-Analysis* (Ernest Jones, Trans.). Boston: Richard Badger. (Later U.S. editions titled *Sex in psychoanalysis*)
- Freud, Sigmund. (1914g). Remembering, repeating, and working-through (further recommendations on the technique of psycho-analysis, II). *SE*, 12: 145–156.
- . (1915a [1914]). Observations on transference love (further recommendations on the technique of psycho-analysis, III). *SE*, 12: 157–171.
- . (1937d). Constructions in analysis. *SE*, 23: 255–269.
- Freud, Sigmund, and Breuer, Josef. (1895d). Studies on hysteria. *SE*, 2: 48–106.
- Greenson, Ralph R. (1967). *The technique and practice of psychoanalysis*. New York: International Universities Press.



Parat, Catherine. (1995). *L'affect partagé*. Paris: Presses Universitaires de France.

Sterba, Richard F. (1940). Dynamics of dissolution of the transference resistance. *Psychoanalytic Quarterly*, 9, 363–380.

Zetzel, Elizabeth R. (1956). Current concepts of transference. *International Journal of Psycho-Analysis*, 37, 369–376.

### Further Reading

Ogden, Thomas H. (1991). Analysing the matrix of transference. *International Journal of Psychoanalysis*, 72, 593–606.

Poland, Warren S. (1992). Transference: “An original creation.” *Psychoanalytic Quarterly*, 61, 185–205.

## TRANSFORMATIONS

Wilfred R. Bion conceived of transformations as the changes that the analysand's sense impressions of emotional experience undergo to become a progressive series of mental realizations. They are akin to the transformations that food undergoes in the digestive system to become protoplasm. The concept also belongs to the mathematical concepts that Bion employed to bring more rigor to psychoanalytic understanding. In this way, he was attempting to make psychoanalysis more scientific. This period in his work overlaps with the next period in his work, developing psychoanalysis as an “intuitionistic science.”

Briefly put, Bion envisions psychoanalytic transformations as the psychoanalyst's attempt to help the analysand transform that part of an emotional experience of which he is unconscious into an emotional experience of which he *is* conscious. Transforming here would be changing the form but not the fundamental nature or invariant aspect of the emotional experience. In this way the analyst helps the analysand achieve private or personal knowledge about his emotional life. Bion states his theory in a rigorous mathematical notation in which his symbols have the following meanings:  $O$  = the symptom or analytic object;  $T$  = transformation;  $t$  = the representation of the transformation;  $K$  = knowledge link;  $\beta$  = beta elements, sense impressions of emotional experience;  $\alpha$  = alpha elements, elements suitable for further mental processing;  $p$  = patient;  $a$  = analyst. Bion states, “I shall regard only those aspects of the patient's beha-

avior which are significant as representing his view of  $O$ ; I shall understand what he says or does as if it were an artist's painting. In the session the facts of his behavior are like facts of a painting and from them I must find the nature of his representations (or, in terms of my notation, the nature of that which I denote by the sign  $T(\text{patient})\beta$ ). From the analytic treatment as a whole I hope to discover from the invariants in this material what  $O$  is, what he *does* to transform  $O$  (that is to say, the nature of  $T(\text{patient})\alpha$ ) and, consequently, the nature of  $T(\text{patient})$ . This last point is the *set* of transformations in the group of transformations, to which his particular transformation ( $T(\text{patient})$ ) is to be assigned. As I am concerned with the *nature* (or ... meaning) of these phenomena, my problem is to determine the relationship between the unknowns:  $T(\text{patient})$ ,  $T(\text{patient})\alpha$ , and  $T(\text{patient})\beta$ . Only in the last of these have I any *facts* on which to work. ... I shall make three assumptions: (i) that the patient is talking about something ( $O$ ); (ii) that something,  $O$ , has impressed him and that he has transformed the impression by the process represented by  $Tp\alpha$  and (iii) that his representation  $tp\beta$  is comprehensible” (Bion, 1965).

Bion considers the emotional experience of the analysand and of the analyst to be  $O$  (the symptom or analytic object) but each has his distinct experience of  $O$ :  $Op$  (patient), and  $Oa$  (analyst). The analyst must, with his alpha function, deduce the transformation  $O \rightarrow Tp\alpha \rightarrow Tp\beta$ , which is then translated by the analyst as  $O \rightarrow Ta\alpha \rightarrow Ta\beta$ .

Bion considers there to be four kinds of transformations in clinical practice: (a) “rigid-motion transformations,” which involve little alteration and which correspond directly to past events that may now be relived in the (classical) transference; (b) “projective transformations,” which correspond to Melanie Klein's concept of projective identification; (c) “transformations in hallucinosis,” which occur only in psychosis, and (d) “transformation in  $O$ ,” by which Bion seems to mean a transformation both *from* the ineffable nature of the analytic object, the analysand's symptom, and *through*  $K$  (the knowledge link), *to* yet another state, that of Absolute Truth or Ultimate Reality, the Godhead.

Bion states, “The bearing on psycho-analysis and interpretation of what I have said may seem obscure; it is this: The beginning of a session has the configuration already formulated in the concept of the God-

head. From this there evolves a pattern and at the same time the analyst seeks to establish contact with the evolving pattern. This is subject to his Transformation and culminates in his interpretation  $T\alpha\beta$ . I am aware of the problems I have left without attempting an approach to their solution. . . . In this book I draw attention to a few of the problems which present themselves in analytic material and offer suggestions for clarifying, first observation and then, assessment of what has been observed" (1965).

*Transformations* (1965) seems to represent Bion's last venture in employing mathematical notation to bring scientific rigor to clinical psychoanalytic phenomena. Transformations in *O* constitute "a bridge to a new science," the intuitionistic, to which he thereafter bent his efforts. Though mathematical, *Transformations* was the third in a series of foundational works that was gradually to alter how analysts regarded clinical material and their personal ( $T(\text{analyst})$ ) relationship to it. Having already defined the mind that had to develop in order to think "the thoughts without a thinker" (beta elements, emotional experiences in themselves), he then undertook to define how these thoughts evolve from sense impressions of emotional experience (beta elements) to alpha elements suitable for further mental processing. From there he defined the steps of "mentally digestive transformation" that these beta, and then alpha, elements must undergo in the analysand and in the analyst in order to qualify for status in a scientific deductive system or fall by the wayside because of invidious *K*. *O* is the beginning and the end of the transformational cycle. Bion's epistemological transformation of psychoanalytic metapsychology was then in place.

JAMES S. GROTSSTEIN

*See also:* Catastrophic change; Dream-like memory; Grid; Hallucinosity; Invariant; Love-Hate-Knowledge (L/H/K links); Vertex.

### ***Bibliography***

Bion, Wilfred R. (1965). *Transformations: Change from learning to growth*. London: Heinemann.

---

## **TRANSGRESSION**

The notion of *transgression* entered psychoanalysis only gradually. In fact, the word already had a well-established meaning in ethnology, a science from which Sigmund Freud drew inspiration. Its definition was to some extent a negative one, in opposition to *taboo* (a term that was itself borrowed from the Polynesian language), *prohibition*, and *law*.

Transgression is anything that involves the contravention of explicit or implicit rules, both in the course of the treatment and in conflictual unconscious functioning, not to mention within the psychoanalytic process itself.

Thus, real and fantasized transgression is at the heart of all psychological mechanisms, as the result, or source, of a conflict. We also encounter it, during a psychoanalytic treatment, in everything that goes against the framework imposed by the fundamental rule. But it is also found, and this time positively, in the wish of Freud and other psychoanalysts to get to the bottom of secrets that seem to be self-evident. This is what drives all scientific research—the longing to understand and master the laws of human functioning, especially when they are obscure.

Thus it is difficult to date the first appearance of the notion, because only *a posteriori* can its implicit presence be discerned in Freud's first writings and in his wish to become an extraordinary hero. As early as *The Interpretation of Dreams* (1900a, ch. 3), the idea of transgression is contrasted with that of an unsatisfied desire able to reach satisfaction in spite of everything that might restrain and prohibit it, via the detour of the dream. Like sociologists, psychoanalysts find that every law is accompanied by criminal infractions of that law—infractions which the law highlights and describes. Like ethnologists, psychoanalysts also find that the strictest laws are always accompanied by rituals.

It was perfectly natural that, in a dialectical movement, the interest shown in everything that can prevent a desire from being fulfilled—and in particular the formalized, absolute, and non-negotiable limits represented by laws and taboos—should shift to what can corrupt them, deviate them, or violate them, in other words, to the mechanisms of transgression. It is obvious that, given our need for an order in which ethics would have its proper place, transgression

---

**TRANSGENERATIONAL.** *See* **Intergenerational**

should at first have been experienced and presented in its negative or pathological aspects—even though Freud insisted right from the start on the inescapable complementarity of desire and law, of law and transgression. Clinical discussions of perversion, as a pathological manifestation or as a neurotic outlet, all turn on the moral status of transgression, just as the current socio-cultural malaise gets to be played out in various disciplines, including within the psychoanalytical community, with the focus on ethical debates.

The conflictual model that lies at the basis of psychoanalytical thought can be observed from different points of view. One can focus on the place, whether this be the unconscious scene, the framework of the psychoanalytical session, or the huge wealth of psychoanalytical theory. One can focus on the model of representation chosen, essentially the oedipal model or that of the father's murder. Or one can focus on a given level—on the oscillation between the individual intrapsychic level and the more or less specific collective level that makes the performance of forbidden actions possible within certain defined areas, of which carnival is one example. Myths have the same role as dreams with regard to internal prohibitive laws. “The legend of Oedipus sprang from some primaevael dream-material” (1900a, p. 263). Finally, we can focus on the model of functioning chosen: pleasure principle against reality principle, life instinct against death drive, or the relative potency of the superego.

Transgression can be found everywhere in the milieu of the unconscious. Psychological functioning is based on the way conflicts between different agencies are dealt with. One's character is formed by rules of behavior that are based on authorizations and prohibitions.

Over the course of each individual's evolution, certain critical moments or moments of transition favor the temptation of transgression. These are the critical periods of one's development; at these times, evolution is rapid, and behavior is particularly active. During early childhood, the anal period, the “age of no,” is a stage at which the child is forever defying parental law. During adolescence, or more precisely at certain moments during the slow evolution of adolescence, the sense of expansion, of new power, and the desire for discovery, can lead to provocative behavior and the deliberate violation of moral and social rules.

During every session of psychoanalysis, a conflict is set up and staged between the law of repression on one

hand, armed with the patient's resistances and defenses and the law of silence which they entail, and on the other the desire shared by the psychoanalyst and the patient to break through that law. Thus the internal conflict is projected and embodied in the transferential relation.

It can be said that all psychoanalytical thinking is built on a transgressive epistemological curiosity. Psychoanalysis as a scientific corpus comes up against the laws of inner repression, but also against the universal or western ethic of sexual repression, the rejection of aggressive desires and, finally, the norms of a rudimentary and reductive scientific logic.

The oedipal model is the summit of psychoanalytical construction. The child's violent desire for the parent of the opposite sex implies the aggressive wish to take the place of the parent of the same sex. This wish is in its turn strongly repressed, due to the love and fear felt by the child for this same parent. To get beyond this conflict requires a means of transgressing the dual prohibition of incest and rejection. The aggressive violence repressed at the time of the oedipal conflict doubtless has an earlier and more archaic origin: it comes from the wish for the father's murder by the horde of brothers, a wish that aims at possessing, interiorizing, and questioning authoritarian paternal powers, however vague and imaginary they may be.

It goes without saying that the manifestations of transgression in the psychoanalytical sense essentially lie on the individual and intrapsychic level. But Freud saw how important this sector of the structural conflict of human thought is for collective phenomena. From *Totem and Taboo* (1912–13a) to *The Future of an Illusion* (1927c) or *Civilization and Its Discontents* (1930a [1929]), he shows that there is a constant oscillation between repressive cultural forces and “the dangerous attribute [...] the quality of exciting men's ambivalence and tempting them to transgress the prohibition” (1912–13a, p. 32). The more authoritarian society is, the more organized repression impels one to interiorize transgressive yearnings—and Freud remarks that so-called primitive societies make more room for transgressive possibilities, even when these might affect an apparently immutable order, if necessary by organizing festivals at which people can shed their inhibitions.

If the pleasure principle leads to the (potentially repeated) satisfaction of desires, the reality principle opposes it as an obstacle on the path to these

satisfactions. From this conflict between the two structures is born a sense of unease: unsatisfied desires seek an outlet. This may be found in dreams, of course, and transgression is there a sort of compromise; these desires may also try to realize themselves to a greater or lesser degree in criminal and perverse acts—at the cost of incurring guilt. In one way, there is transgression whenever there is a refusal to compromise. The idea of conquering reality is a dream of omnipotence which can degenerate into delirium, this in turn explains both the fanatical dedication of scientists and the fascination for taboos.

The same duality (the same intrapsychic duality) is found in the opposition proposed by some theorists between the life instincts and the death drive. Conflict shifts from the need to fulfill desires when faced with obstacles to the need to fulfill contradictory objectives. Ambivalence rules. These two approaches, however, are still dualistic, and they describe a conflict against an authority such that, whatever the result, a sense of guilt is generated. “Thus we know of two origins of the sense of guilt: one arising from fear of an authority, and the other, later on, arising from fear of the superego” (1930a, p. 127), wrote Freud.

In fact, it is with the advent of the superego that the problem of transgression reaches its apogee, even if it was perceptible beforehand. As Freud put it, “Conscience is the internal perception of the rejection of a particular wish operating within us” (1912–13a, p. 68). Forbidden desires are at the center of neurotic patterns of behavior, and the prohibitions against these are all the stronger as they are more powerfully interiorized, *inter alia* under the influence of culture, and bolstered by family habits and rules.

Whether limits to the emergence of desires impose themselves subtly (as taboos) or whether they are explicit and socially recognized, transgression or the temptation to transgress are part and parcel of the same trend, against which the superego takes shape as an inner law. To see the truth of this, one needs only to recall that the rules of taboos always anticipate a punishment for transgression, and thus anticipate the transgression itself.

Much has been said about the revolution in thought which led to, or accompanied, psychoanalysis. Psychoanalysis has also been associated—either to support it or to denigrate it—with the so-called sexual revolution, which enabled people to think and say things that, until that period, had been kept in silence or

suppressed. Another revolution, less spectacular but just as important, lay in accepting and even giving a positive evaluation to drives that had hitherto been considered as sins, pathological symptoms, or antisocial types of behavior: violence, aggression, and the whole list of transgressions that go with them.

This revolution questions, through the unconscious forces it reveals, the ethical norms of the majority in any given society. Transgression is no longer a residue or a deplorable side effect of psychological functioning. It is an inescapable part of it and, what is more, by favoring inventiveness and complexity of thought, it becomes something positive.

SIMON-DANIEL KIPMAN

*See also:* Megalomania; Moral masochism; Neurosis; Parricide/murder of the father; Primitive horde; Taboo; “‘Uncanny,’ The”.

### **Bibliography**

- Freud, Sigmund. (1900a). The interpretation of dreams. Part I, *SE*, 4: 1–338; Part II, *SE*, 5: 339–625.
- . (1912–13a). Totem and taboo. *SE*, 13: 1–161.
- . (1927c). The future of an illusion. *SE*, 21: 1–56.
- . (1930a [1929]). Civilization and its discontents. *SE*, 21: 57–145.

---

## **TRANSITIONAL OBJECT**

The term *transitional object* was coined in 1951 by Donald Winnicott as a designation for any material object (typically something soft—a piece of cloth, say, or part of a plush toy) to which an infant attributes a special value and by means of which the child is able to make the necessary shift from the earliest oral relationship with the mother to genuine object-relationships.

Winnicott first spoke of the transitional object on May 30, 1951, in a paper read before the British Psychoanalytical Society and published in 1953 under the title “Transitional Objects and Transitional Phenomena. A Study of the First Not-Me Possession.” This article was recast twenty years later and incorporated into Winnicott’s *Playing and Reality*, a book concerned entirely with transitional phenomena.

In his observation of infants, Winnicott noted that between the ages of four and twelve months children would often become attached to a particular object that they invested with a primordial significance. This object would be manipulated, sucked, or stroked, and often became an indispensable aid for falling asleep. Parents recognized its value, taking it along everywhere and allowing it to get dirty in the realization that washing would introduce a break in continuity in the infant's experience and destroy the object's meaning and special worth. Such objects in fact constituted a defense against depressive anxiety.

As early as 1951 Winnicott warned against the risk of his thinking being reified. What interested him was this "first not-me possession" and the zone it occupied between the sucked thumb and the teddy bear, between early oral erotism and a true object-relationship, between subjectivity and objectivity, between primary creativity and the projection outwards of what had been introjected. In 1971, in his introduction to *Playing and Reality*, Winnicott wrote that "what I am referring to . . . is not so much the object used as the use of the object" (1971, p. xii).

To explain the origin of the transitional object, Winnicott went back to the first connection with the mother's breast. The mother, he argued, puts the actual breast in a place where the infant is ready to create it and experience an illusory omnipotence in consequence. Later on, the establishment of the reality principle and the inevitable disillusion associated with this will be tolerated by virtue of the transitional object, which allows the child to exercise its feelings of omnipotence in a playful manner. The child arrogates rights over this object, which, though loved passionately, is also expected to resist and triumph over hate. In libidinal terms, the activity involved here is of an oral kind. The object is just as highly cathected with narcissistic libido as with object-libido. It is not recognized as part of either external or inner reality. There is thus an essential paradox at the heart of this conceptual framework: the baby creates the object, yet the object was already there, waiting to be created and cathected. This paradox will never be resolved: in the course of normal development, the object is destined to be gradually decathected, losing its significance as diffuse transitional phenomena spread over the entire intermediate realm between subjective inner reality and common external reality, until the whole sphere of

culture is included (art, religion, imaginative life, scientific invention, and so on).

The transitional object and transitional phenomena may be conceived of in three ways: as typifying a phase in the child's normal emotional development; as a defense against separation anxiety; and, lastly, as a neutral sphere in which experience is not challenged—an area of play and illusion.

For Winnicott the transitional object could sometimes be part of abnormal development and become associated with some types of pathology. The child could not make use of such an object unless "the internal object is alive and real and good enough" (1917, p. 11), and this depended on the quality of the maternal care received. Should the external object be bad or absent, the internal object could take on a persecutory character. And should the failure of the external object persist, the internal object would be meaningless and the transitional object would likewise lose all significance and possibly take on a fetishistic character. Winnicott also mentioned drug addiction, lying, and theft as ultimately linked in some cases to a pathology of transitional phenomena.

Several authors have criticized Winnicott's view of the transitional object. Melitta Sperling feels that such objects are pathological manifestations of a specific disturbance of object-relationships. Esther Bick (as cited by Michel Haag) evokes an adhesive clinging that results from a defective introjection of the mother's containing function. And in Françoise Dolto's view, children with "enough words of love and opportunities for play of a motor kind" available have no need of transitional objects, which should therefore be treated from the outset as fetishistic.

NORA SCHEIMBERG

*See also:* Object; Transitional object; Transitional object, space.

### **Bibliography**

- Dolto, Françoise. (1984). *L'Image inconsciente du corps*. Paris: Seuil.
- Haag, Michel. (1984). *À propos des premières applications françaises de l'observation régulière et prolongée d'un bébé dans sa famille selon la méthode de Mrs. Esther Bick: Des surprises profitables*. Privately published.

Sperling, Melitta. (1963). Fetishism in children. *Psychoanalytic Quarterly*, 32, 374–92.

Winnicott, Donald W. (1953 [1951]). Transitional objects and transitional phenomena. A study of the first not-me possession. *International Journal of Psycho-Analysis*, 34, 89–97.

———. (1971). *Playing and reality*. London: Tavistock.

### Further Reading

Brody, Sylvia. (1980). Transitional objects: Idealization of a phenomenon. *Psychoanalytic Quarterly*, 49, 561–605.

Giovacchini, Peter L. (1984). The psychoanalytic paradox: The self as a transitional object. *Psychoanalytic Review*, 71, 81–104.

Greenacre, Phyllis. (1969). The fetish and the transitional object. *Psychoanalytic Study of the Child*, 24, 144–164.

## TRANSITIONAL OBJECT, SPACE

Transitional objects (Donald Winnicott) originate in that phase of an infant's development when inner and outer reality begin to become apparent. They are at once "me" and "not-me," and are transitional in that they facilitate the transition from the omnipotence of the tiny baby for whom external objects have not yet separated out, to the capacity to relate to "objectively perceived" objects.

Transitional space (intermediate area, third area) is that space of experiencing, between the inner and outer worlds, and contributed to by both, in *which primary creativity* (illusion) exists and can develop ("Transitional Objects and Transitional Phenomena," Winnicott, 1951; further developed in Winnicott, 1971). From as early as 1945, Winnicott, from within his own concepts of object-relations, approached the infant's developing capacity to discover and adapt to reality. He described first the common patterns of infancy in which a very young baby first finds a thumb, or a fist, to suck, and may stroke his own face, gather a piece of material and suck or stroke it, or make babbling noises; Winnicott assumed accompanying fantasy and used the term *transitional* for these phenomena.

Later in infancy it may happen that both the activity and the object become necessary when the baby is going to sleep, or anxious. Babies may discover a particular object, perhaps a soft toy or a blanket, or a sound, or

piece of behavior, that fulfils the purpose, and this, the transitional object, becomes important and is recognized to be so by the parents, who unconsciously know that it represents a continuity of experience that the baby needs. For this reason parents know that it is not to be changed, or even washed, but must accompany the infant, to be loved or attacked as the baby fancies. This "transitional object" becomes the first "not-me" possession, and while it is symbolic of a part-object, is important in that it is neither the baby nor that object. Winnicott listed the special qualities of the relationship with the object, which must survive; must, from the baby's point of view, come from neither without nor within; will become deattached—lose its significance, not forgotten, not mourned, but losing meaning, at that stage when a wider cultural field has come into being. In early infancy the "good-enough mother" provides a near-perfect environment, allowing the baby the illusion of unity and omnipotence—Winnicott stated that the infant "creates" the breast—"primary creativity," which is known as a "subjective object." The disillusion necessary to permit awareness of outside reality must be dosed to the infant in such a way that the infant's creativity survives the passage to the recognition of objective reality.

Winnicott used the term *transitional* to describe the "intermediate" or "third area," "between the thumb and the teddy bear, between the oral erotism and the true object-relationship, between primary creative activity and projection of what has already been introduced, between primary unawareness of indebtedness and the acknowledgment of indebtedness ("Say ta")" (Winnicott, 1951). It is in this area, where fantasy and reality overlap, that creativity, including the basis for adult cultural life, and play originate (Winnicott, 1971). Winnicott compared this with the therapeutic situation, where the worlds of the patient and analyst overlap, echoing Freud's concept of the analytic playground.

Related subjects include:

- Fetishistic objects—one possible fate of the transitional object, according to Winnicott.
- Illusion of unity within a framework—Milner.
- Autistic object—Tustin.
- Self-object—Kohut.
- Transformational object—Bollas.
- Transitional stage/quasi-independence—Fairbairn.

Possibly the most widely known of Winnicott's contributions, especially in the worlds of paediatrics and child care, the concepts of transitional phenomena and the thinking about illusion are firmly rooted in his object-related developmental viewpoint and underlie Winnicott's ideas about creativity, which according to him is a primary human element. The popular acceptance of the idea should not be allowed to disguise the importance of this line of Winnicott's thinking, which, despite the incorporation of his concept of paradox into his style of writing, eventually provides the foundation for his theories of play with its relationship to creative analytic work, and also his late, subtle, and important paper "The Use of an Object and Relating Through Identifications" (1971), in which he charts a further stage of change from that of "object-relating," when the object, while separate, is felt to be still under the omnipotent control of the infant, to that of "object-usage," when the object is allowed reality and autonomy.

JENNIFER JOHNS

See also: Transitional object; Transitional phenomena.

### **Bibliography**

Winnicott, Donald. (1953). Transitional objects and transitional phenomena. *International Journal of Psycho-Analysis*, 34, 89–97; and in *Collected papers, through paediatrics to psychoanalysis* (p. 229–242). London: Tavistock, 1958. Additional material was added to the paper in his *Playing and reality*. (pp. 1–30) London: Tavistock, 1971.

———. (1958). Primitive emotional development. In *Collected papers, through paediatrics to psychoanalysis* (pp. 145–156). London: Tavistock. (Original work published 1945)

———. (1971). The use of an object and relating through identifications. In his *Playing and reality* (pp. 101–121). London: Tavistock.

### **Further Reading**

Brody, Sylvia. (1980). Transitional objects: Idealization of a phenomenon. *Psychoanalytic Quarterly*, 49, 561–605.

Giovacchini, Peter L. (1984). The psychoanalytic paradox: The self as a transitional object. *Psychoanalytic Review*, 71, 81–104.

Greenacre, Phyllis. (1969). The fetish and the transitional object. *Psychoanalytic Study of the Child*, 24, 144–164.

## **TRANSITIONAL PHENOMENA**

The original concept of *transitional phenomena* was used by Donald Winnicott to describe the intermediate area of human experience between inner reality and the outside world. The prototypical example is that of the transitional object, the first *not-me* possession of the baby. Thus a real, usually soft object is found by the baby and used as a defense against anxiety. The transitional object represents a real paradox in that it is not an internal object; it is a possession yet it is not an external object either. It grows out of the baby's relationship with the breast (which represents the whole technique of mothering) and his own body. For example, while sucking on his thumb he weaves *not-me* objects into his own autoerotic experience and personal pattern. Thus the transitional object allows for the illusion of infantile omnipotence at the same time as it forms a bridge to the outside world and the process of disillusion and the development of a shared reality. The ordinary care of the mother closely adapting to and meeting her infant's immediate needs fosters in the infant the illusion that what he desires he actually creates.

Transitional phenomena as a class of experiences also represent the use of illusion in allowing the creative co-existence of primary creativity and objective perception based on reality.

Winnicott presented his formulation of transitional phenomena to the British Psycho-Analytic Society in 1951, and this was published in 1952 in a paper, "Transitional Objects and Transitional Phenomena"—subtitled "A study of the first *not-me* possession." The paper was republished in his collected works, *Through Paediatrics to Psychoanalysis* (1958), and is the key paper in his influential and popular book *Playing and Reality* (1971).

The notion of transitional phenomena is central to the framework of ideas which Winnicott uses to chart the course of the development of self, locating the self firmly and inextricably in the context of maternal care, the family and the wider world. Winnicott used his thousands of observations of infants and parents together to build up his idea of the baby's inner world of fantasy, illusion, and omnipotence. The mother, by intuitively anticipating and adapting to the baby's immediate physical needs, allows the infant to build up the illusion that he creates that which his mother provides. Between the age of four to eighteen months

there may then emerge some thing or phenomenon (which may be a sound, mannerism, or the mother herself) which the baby uses to defend himself against anxiety, especially when falling asleep.

Winnicott says the transitional object has specific properties: the infant creates it himself, he can be both affectionate and aggressive to it; it must not change, unless changed by the infant; it must survive loving, hating, and aggression; it must seem to have vitality or reality of its own; it is neither a hallucination nor comes from within the baby; it is gradually detached, but not lost and forms the basis of play, culture, and dreaming.

The patient's use of transitional phenomena can help in understanding psychopathological conditions such as fetishism, lying, stealing, and drug addiction. Winnicott (1971) describes a case of a boy with anxiety and obsessional symptoms where the boy's use of string is central to understanding both these inner and outer experiences. By providing the illusion of omnipotence and gradual disillusionment, parents set up a transitional space within which develop the child's creativity and capacity to play: "on the basis of play is built the whole of man's experiential existence" (1971). Play is a serious and necessary component of psychic life which forms part of adult life and culture. Playfulness and the use of transitional space and transitional phenomena form the foundation of much of Winnicott's psychoanalytic technique.

The transitional object is a concept that has entered the popular culture as the apparently ubiquitous security blanket or the teddy bear. There can be a misapprehension that such physical objects are necessary for healthy psychological development. Winnicott did not imply this but, like many of his concepts, transitional phenomena remain enigmatic and hard to define. This elusive sense seems to be just what he seeks to describe in the child's approach to the "relationship between what is objectively perceived and what is subjectively conceived of." This is indicative of Winnicott's imaginative and at times idiosyncratic metapsychology.

PAUL CAMPBELL AND ANN MORGAN

*See also:* Addiction; Child's play (the); Negative, work of; Object; Omnipotence, infantile; Primary object; Psychosomatic limit/boundary; Representation; Squiggle; Transitional object; Transitional object, space; Wish, hallucinatory satisfaction of a.

### Bibliography

- Hamilton, Victoria. (1982). *Narcissus and Oedipus—The children of psychoanalysis*. London: Routledge and Kegan Paul Ltd.
- Winnicott, Donald. (1975). Transitional objects and transitional phenomena. In: *Through paediatrics to psycho-analysis* (p. 229–242). London: Hogarth Press. (Original work published 1953)
- . (1980). *Playing and reality*. Harmondsworth: Penguin. (Original work published 1971)

### TRANSLATION

There are a large number of occurrences of the verb *übersetzen* ("to translate") and the noun *Übersetzung* ("translation") in Freud's work, indicative of his interest in translation, although the terms had no specific conceptual value for him within the field of psychoanalysis. However, non-German readers should bear in mind the proximity in German of *Übersetzung* and *Übertragung* ("transference"). What psychoanalysts refer to as "transference" is, in German, also a translation, a carrying over.

Freud's interest in translation was manifest early in his career: while doing his military service he translated an essay by John Stuart Mill and, on his return from his stay at the Salpêtrière, impressed by Charcot's clinical method, he translated two of the Charcot's main works, as well as two works by Bernheim, which he felt were essential for a scientific understanding of hysteria and the use of therapeutic methods in hypnosis. For Freud the experience of translation was contemporary with his discovery of psychoanalysis as a therapeutic practice. Ernest Jones emphasized Freud's gifts as a translator (Pollak Cornillot, 1990). It should come as no surprise, therefore, to find that *translation* infiltrated his thought as a metaphor for a large number of psychic processes.

In his earliest writings and with the appearance of the concept of repression, translation, in its primary sense of "to bring over," became a way of picturing the transformation of those psychic contents reaching consciousness, repression being thus defined (Freud to Fliess, December 6, 1896) as a "defect of translation," an absence of conscious expression. The work of dream interpretation likewise resembles a translation of the language of the unconscious into the language



of consciousness, of the remembered dream content into its hidden sense: “Interpreting a dream consists in translating the manifest content of the dream into the latent dream-thoughts, in undoing the distortion which the dream-thoughts have had to submit to from the censorship of the resistance” (1907a, p. 59). But at the same time Freud cautioned against the tendency to overestimate the importance of symbols and reduce the work of dream translation to the mere decoding of symbols, and to ignore the ideas that present themselves to the mind of the dreamer during analysis. Finding the hidden meaning was more complex than the simple transliteration of the signs of the unconscious system into the signs of the conscious one. Elsewhere (1918b [1914]), Freud uses the term *translation* more generically, to designate the psychoanalyst’s interpretation of a psychic phenomenon: for example, the fear of being eaten by the wolf “is translated” into the fear of being raped by the father. More recently André Green (1997/2000) has rediscovered the richness of the “hypothesis of translation” present throughout Freud’s work.

MICHÈLE POLLAK CORNILLOT

See also: Biblioteca Nueva de Madrid (Freud, S., *Obras completas*); France; Interpretation; *Opere* (writings of Sigmund Freud); *Standard Edition of the Complete Psychological Works of Sigmund Freud*; Symbol.

### Bibliography

- Freud, Sigmund. (1907a). Delusions and dreams in Jensen’s “Gradiva.” *SE*, 9: 1–95.
- . (1918b [1914]). From the history of an infantile neurosis. *SE*, 17: 1–122.
- Green, André. (2000). *The chains of eros: The sexual in psychoanalysis* (Luke Thurston, Trans.). London: Rebus. (Original work published 1997)
- Mahony, Patrick. (1980). Toward the understanding of translation in psychoanalysis. *Journal of the American Psychoanalytic Association*, 28, 461–473.
- Mijolla, Alain de. (1991). L’édition en français des “Œuvres” de Freud avant 1940. Autour de quelques documents nouveaux. *Revue internationale d’histoire de la psychanalyse*, 4, 209–270.
- Pollak Cornillot, Michèle. (1990). *Freud traducteur. Introduction à la traduction des œuvres de Freud*. Doctoral dissertation, Université René-Descartes, Paris.

### Further Reading

- Amati-Mehler, Jacqueline, et al. (1993). *The babel of the unconscious. Mother tongue and foreign languages in the psychoanalytic dimension*. Madison, CT: International Universities Press.

---

## TRANSMUTING INTERNALIZATION

Transmuting internalization is a process that participates in the formation of psychic structure, as postulated by Heinz Kohut. It is an extension of Freud’s concept of mourning. For Freud, the loss of an object causes mourning to establish a presence within the psyche. If this model is seen as the basis of all losses, including nontraumatic and phase-specific losses, then it follows that any failure or absence of a sustaining object can lead to the establishment in the psyche of whatever function that object has served. Minute losses or absences lead, not to wholesale identification with the object, but to internal structures that need bear no resemblance to the lost object but merely capture the function served by the object. Nontraumatic loss and internalization, called optimal frustration, is an essential feature of normal development. Parental absences, disappointments, failures, and age-appropriate responsibilities help children gradually develop psychological structure. *Psychological structure* refers to an enduring function, a function that results from the progressive neutralization occupying the area of the psyche not represented by repression. Psychoanalytic treatment parallels normal development when the analyst causes transmuting internalizations by initiating similar phase-specific failures.

ARNOLD GOLDBERG

See also: Action-thought (H. Kohut); Progressive neutralization.

### Bibliography

- Kohut, Heinz. (1971). *The analysis of the self*. New York: International Universities Press.
- . (1977). *The restoration of the self*. New York: International Universities Press.

---

## TRANSSEXUALISM

Transsexualism is characterized by the desire to belong to the sex opposite one’s assigned, biological sex, and by the demand for a reassignment of one’s sex with the

help of hormones and surgery—all this in the absence of any biological anomaly that is detectable with current means of investigation. This distinguishes transsexualism from intersex states and pseudo-hermaphrodites. With transsexualism, people speak of an unshakeable conviction of belonging to the other sex. It would be more appropriate to speak of an indomitable desire to live as a member of the other sex, as well as the desire to bear a corporal sign of this belonging, which is what makes transsexualism historically unique.

In 1953 the endocrinologist and sexologist Harry Benjamin was the first to name the syndrome that had previously been confused with transvestism. Perhaps he had retained the expression “Psychopathia transsexualis” used by D. O. Cauldwell in 1949, although he claimed he had no conscious memory of it, or “seelischer Transsexualismus” the expression used by Magnus Hirschfeld in 1923, although he makes no mention of it. It took more than ten years for the term *transsexualism* to become accepted.

In the same year, 1953, the Journal of the American Medical Association (JAMA) published the observations of C. Hamburger, G. K. Stürup, and E. Dahl-Iversen concerning the case of George, operated on in Denmark, who became Christine Jorgensen. Benjamin declared that psychotherapy was powerless to treat transsexualism and that the only possible treatment was sex conversion surgery along with hormone replacement therapy for life. A large number of specialized centers opened in the United States for treating the sexual identity disorders that Norman Fisk called “gender dysphoria” in 1973. However, some of those subsequently closed down.

Hormono-surgical sex reassignment hardly deserves to be called a treatment. A palliative at best, it consists in transforming a healthy, hormonally well-balanced, and functioning organism into an artificial intersex, a mutilated organism that requires hormone replacement therapy. In order to justify such an unusual treatment it would be necessary to prove that although they may be compromising their physical health, patients derive benefits from it in terms of their mental health. However, existing follow-up studies are incomplete and insufficient. Not all subjects continue to be seen. Those who are seen are generally satisfied. With few exceptions they do not regret their operation but they end up realizing that their dearest wish, to really be changed into a human being of the opposite sex, has remained unrealizable.

Compared to female transsexuals becoming male, male transsexuals becoming female constitute a larger group (three biological males for every biological female demanding reassignment) that is more heterogeneous, suffers from more serious pathologies, and is characterized by very mediocre social integration (prostitution, public assistance). Many patients request sex reassignment after a period of their lives spent as transvestites or homosexuals. The most cautious physicians defending hormono-surgical sex reassignment make a point of identifying patients who essentially suffer from identity disorders, whom they refer to as true or primary transsexuals, which they consider to be the only indication for hormono-surgical sex reassignment.

An effort has been made to present primary transsexuals (male to female) as normal subjects who, by reversing their identity, inform their mothers of the truth of their primary identification (Robert Stoller). It is difficult to consider that transsexuals do not suffer from serious psychic disorders at the narcissistic level. Psychoanalysis has extended its field of application from the neuroses to borderline cases, and in this respect it may be possible to try to treat transsexuals. The difficulty is great because denial and splitting dominate the mental organization. They put everything on the corporal level and nothing on the psychic. The availability of medical hormono-surgical sex reassignment makes it more difficult to reach them through psychoanalytic psychotherapy. Interesting attempts have nevertheless been made, often by psychoanalysts from the school of self-psychology (particularly Lothstein).

Treatment of children suffering from sexual identity disorders shows promise if the parents are treated at the same time, and in this way observing how the children respond to their parents' problems by thinking that they should belong to the opposite sex in order to be loved by them.

COLETTE CHILAND

*See also:* Gender identity; Masculine protest (individual psychology); Self-representation.

### **Bibliography**

- Benjamin, Harry. (1953). Transvestism and transsexualism international. *Journal of Sexology*, 7 (1), 12–14.
- Chiland, Colette. (1997). *Changer de sexe?* Paris: Odile Jacob.

Stoller, Robert J. (1968). *Sex and gender: On the development of masculinity and femininity*. New York: Science House.

———. (1985). *Observing the erotic imagination*. New Haven, CT: Yale University Press.

Zucker, Kenneth J., and Bradley, Susan J. (1995). *Gender identity disorder and psychosexual problems in children and adolescents*. New York: Guilford Press.

---

## TRATTATO DI PSICOANALISI

Cesare Musatti's *Trattato di psicoanalisi* (Treatise on psychoanalysis) was written in the 1930s, when the first generation of Italian psychoanalysts were active and when psychoanalysis was first beginning to reach the public. Unfortunately, its publication was hampered by an idealist, fascist culture that resisted the challenges of psychoanalysis.

The treatise was based on lectures in experimental psychology that Musatti gave from 1933 to 1935 at the University of Padua. He attempted to provide a solid foundation for young physicians who were interested in the new methods of psychotherapy and were considering using them professionally. At the same time he wanted to offer the Italian public a solid popular work about psychoanalysis that would sweep away the prejudices and falsehoods then prevalent about the field.

Although the book was completed in 1938, the political and cultural situation in Italy presented an obstacle to its publication for over a decade. At the time Nazi racism, which existed in Italy in diluted form, considered psychoanalysis a Jewish science and sought to destroy the work of Freud and his followers—physically and in spirit. For years the manuscript remained in Musatti's desk. It was finally published in 1949 by Boringhieri. The work was subsequently reprinted several times, first by Einaudi.

Musatti's *Trattato* consists of six parts. He retraced the origins of Freud's discovery, from dreams to free association, from fantasy to the arts, being careful to define mental pathology as well as the structure of human personality. His goal was to introduce psychoanalysis to scientists and academicians, and thereby win their support. Ironically, errors like the "doctrine of instincts," the name given by Musatti to a section of his book, could have been the source of a certain resistance to his work. This turned out not to be the case, and the confusion remained between drive and instinct—a key Freudian distinction that is ignored in

the *Standard Edition* of Freud's works. Notwithstanding its limitations, the *Trattato*, known as the "freudino" (the little Freud) by students, has the merit of having been the first essay to describe Freud's work systematically without excessive distortion, at least in comparison with earlier Italian-language summaries.

GIANCARLO GRAMAGLIA

See also: Musatti, Cesare.

### Source Citation

Musatti, Cesare. (1949). *Trattato di psicoanalisi*. Turin, Italy: Boringhieri-Einaudi.

### Bibliography

Gramaglia, Giancarlo. (1995). *Discorsi/scritti di psicoanalisi*. Turin, Italy: Il Laboratorio.

---

## TRAUMA

In its psychoanalytical sense, *trauma* denotes an event of such violence and suddenness that it occasions an inflow of excitation sufficiently strong to defeat normally successful defense mechanisms; as a general rule trauma stuns the subject and, sooner or later, brings about a disorganization of the psychic economy.

*Trauma* (a wound), a term borrowed from ancient Greek, was at first used in surgery to denote a violent injury from an external cause that breached the body's integrity. (*Traumatism* is used occasionally as a synonym, and occasionally to refer to any condition resulting from trauma.) The term eventually made its way into common usage, its psychological sense coming to the fore as its employment spread from medicine to psychoanalysis.

In the context of late-nineteenth-century causation, the notion of trauma was inseparably linked to the ideas of shock and physical breach, and it was regularly invoked to explain a variety of syndromes, among them traumatic neurosis. Freud was part of this current of thought, and, following Charcot, assigned trauma a determining role in the etiology of hysteria; then, along with Breuer (1893a), he moved from the idea of real, physical trauma to that of a "psychical

trauma” (pp. 5–6), with the stress laid no longer on the reality of the event but rather on its mental representation, experienced as an internal “foreign body,” which is the source of the excitation. This was a radical shift relative to the theories of the time, and an epistemological leap of great import, for it was the foundation stone of psychoanalysis.

What made an experience traumatic for Freud was indeed the incapacity of the psychical apparatus to discharge the excessive excitation in accordance with the principle of constancy, whether that excitation arose from the pathogenic action of a single brutal event or of a series of incidents having a cumulative effect. This economic view of things was part of psychoanalysis from the beginning, and it is crucial to the understanding of the psychoanalytical notion of trauma. Even at this early period, Freud distinguished two models: the first, evidenced by hysteria, involved the absence of discharge, whereas in the second, operative in the actual neuroses, discharge took place but did so at the wrong time and place, and independently of the object. The economic perspective provided the connection and continuity between the successive theories proposed by Freud as he considered trauma in terms of a causal relationship: the first of these theories was modeled on Charcot’s hystero-trauma, but this traumatic theory was very soon replaced by the theory of seduction. Founded on clinical observation, this theory led Freud to assert that the trauma was always of a sexual nature and that it had two moments: the first, the moment of fright, confronted the child prematurely with the sexual conduct of an adult seducer; this the child experienced uncomprehendingly, and its meaning and traumatic effect came into play only after puberty, on the occasion of a second scene that served to reactualize the repressed memory of the earlier one. When the frequency with which his patients produced accounts of such early events obliged Freud to question their reality and treat them instead as products of fantasy, the theory of seduction lost a good deal of its interest; at the same time, its temporal aspect—the process of “deferred action” (*après coup*) of which the case of Emma provided the archetypal instance—remained essential to Freud’s explanation of the trauma, whose importance in the triggering of neuroses, however, he now qualified by taking into account such factors as individual predisposition, the trauma’s place in the subject’s history and mental organization, and the circumstances of the event.

The thinking sparked by the war neuroses gave the notion of trauma a new lease on life, while so reinforcing the energetic point of view that in 1916 Freud did not hesitate to say that “the term ‘traumatic’ has no other sense than an economic one” (1916–17a [1915–17], p. 275). Thus a trauma, by its simple intensity, could produce an instinctual hypercathexis capable of breaching the protective shield against stimuli. In order to stem this influx, which the ego, not having been prepared by anxiety to confront the danger, was all the more incapable of neutralizing, the psychical apparatus would mobilize all available energy and establish countervailing charges. Should these defensive strategies be insufficient, the apparatus would have to bind the excitation compulsively, “beyond the pleasure principle,” so as to lower it gradually to a tolerable threshold (1920g, p. 31).

In *Beyond the Pleasure Principle*, where the importance assigned to the compulsion to repeat led Freud into speculation about the death instinct, the question arose of what principle governed repetition. Was it Thanatos, striving for absolute discharge, as in certain behaviors analogous to the traumatophilia described by Karl Abraham in 1907? Or Eros, aiming to attain mastery through the gradual resolution of tension and thence accede to the power of symbolization, as well illustrated by repetitive dreams recounted in the analytic session and by reproductions in the transference? In fact, where the work of analysis made it possible for the subject to recover and work through repressed material, the binding function could triumph over death-oriented repetition. In that case, deferred effects, by making reorganizations possible, would have been the motor of change.

Finally, in the context of Freud’s revised theory of anxiety (1926d), the stress fell on the state of helplessness: what the baby experiences, subjected without recourse to a state of tension in the absence of its mother, was taken as the prototype of all traumatic situations. In this instance with the signal function of anxiety as yet not developed, the ego is overwhelmed by an eruption of instinctual forces it is powerless to contain.

Freud’s reflections of 1926 have given rise to the present-day notion of *narcissistic trauma*, which refers to the ego’s inability to bind excitation resulting from a loss, whether the loss of an object or a loss of a narcissistic kind. This classification is justified in terms of the symptomatology often presented by patients (rumination, repetitive dreams), who may thus be

thought to be expressing a pathological mourning under the influence of deferred effects (*après coup*).

This category has led to a questionable broadening of the concept, for it tends to water down the specificity assigned to trauma in Freud's early works: Systematically treating all and every physical or psychic injury as a trauma runs counter to the psychoanalytic view, for which a trauma cannot be reduced to the level of events alone; at the same time, this level should always be taken into account, precisely because not to do so is to court the danger of further pathological development in a traumatic mode.

FRANÇOISE BRETTE

*See also:* Activity/Passivity; Actual; Amnesia; Annihilation anxiety; Anxiety dream; Arpád the Little Chanticleer (case of); *Beyond the Pleasure Principle*; Breakdown; Choice of neurosis; Complementary series; Deferred action; Deprivation; Disorganization; Dream of the Wise Baby; Fixation; Fright; Helplessness; Incompleteness; Memory; Mnemic symbol; Narcissistic injury; Negative therapeutic reaction; Nightmare; Pain; Phylogenesis; Pleasure in thinking; Protective shield, breach of; *Proton-Pseudos*; Psychic causality; Psychic reality; Real trauma; Real, the; Reminiscence; Repetition compulsion; Sexual trauma; Tact; *Trauma of Birth, The*; Traumatic neurosis; War neurosis.

### **Bibliography**

- Abraham, Karl. (1979). The experiencing of sexual traumas as a form of sexual activity. In *Selected papers on psychoanalysis*. New York: Brunner/Mazel. (Original work published 1907)
- Brette, Françoise. (1988). Le traumatisme et ses théories. *Revue française de psychanalyse*, 52 (6), 1259–84.
- Freud, Sigmund. (1916–17a [1915–17]). *Introductory lectures on psycho-analysis*. *SE*, 15–16.
- . (1920g). Beyond the pleasure principle. *SE*, 18: 1–64.
- . (1926d). Inhibitions, symptoms and anxiety. *SE*, 20: 87–172.
- Freud, Sigmund, and Breuer, Josef. (1893a). On the psychical mechanism of hysterical phenomena: Preliminary communication. *SE*, 2: 1–17.
- . (1895d). Studies on hysteria. *SE*, 2.

### **Further Reading**

- Levine, Howard (Ed.). (1990). *Adult analysis and childhood sexual abuse*. Hillsdale, NJ: Analytic Press.

Sandler, Joseph, et al. (1991). Conceptual research in psychoanalysis: Psychic trauma. *International Review of Psychoanalysis*, 18, 133–142.

Terr, Lenore. (1990). *Too scared to cry: Psychic trauma in childhood*. New York: Harper and Row.

Van Der Kolk, Bessel, et al. (1996). *Traumatic stress: The effects of overwhelming experience on mind, body, and society*. New York: Guilford.

---

## **TRAUMA OF BIRTH, THE**

First published in 1924, Otto Rank's *The Trauma of Birth* took as its starting point a note that Freud added to his *The Interpretation of Dreams* in 1909: "Moreover, the act of birth is the first experience of anxiety, and thus the source and prototype of the affect of anxiety" (1900a, pp. 400–401n).

Rank set out to identify "the ultimate biological basis of the psychical," the very "nucleus of the unconscious" (p. xxiii). For him this was the physical event of birth, whereby the infant passes from a state of perfectly contented union with the mother to a state of parlous separation via an oppressive experience of asphyxiation, constriction, confinement in the vaginal canal, and so on—all feelings recognizable in anxiety states of every kind. It was the struggle against this traumatic experience of birth, in Rank's account, that structured the fantasy life of the child, including the disavowal of the difference between the sexes, infantile sexual theories, and oedipal scenarios. Castration anxiety was a defensive derivative of the anxiety associated with the birth trauma.

Rank supported his thesis with case notes, notably concerned with terminations which according to him always brought up fantasies of a "second birth." But for the most part he relied on data derived from social myths and rites exemplifying what he called "heroic compensation," religious sublimation, artistic idealization, or philosophical speculation. The very abundance of the material thus adduced, and the author's stated aim of accounting for all processes of hominization and all cultural evolution in terms solely of the trauma of birth, were bound to leave the reader perplexed. Rank's evidence nevertheless warrants more attention than contemporary psychoanalysts were willing to accord it. Indeed a multitude of themes—falling, constriction within a narrow space, feelings of

being lost in limitless space, the importance of very early relations with the mother, or primitive anxieties foreshadowing castration anxiety—were distinctly novel in the psychoanalytic literature as of 1924.

The clumsy presentation of these ideas, however, along with the author's overreaching ambition, the lack of method in his argument, and the failure to buttress his thesis with analytical clinical material, all contributed to the rejection not only of his work but also of Rank himself, who broke with the psychoanalytic movement in 1926 after Freud's condemnation of his ideas in *Inhibitions, Symptoms and Anxiety* (1926d).

Beyond the question of the weaknesses of Rank's book, it is reasonable to consider what psychoanalytic reasons might have occasioned this rejection of his ideas in favor of the primacy of oedipal conflict as crucial to the organization of neurotic pathology, or of castration anxiety as the prototype under which all other forms of anxiety were subsumed. In a postscript to the French edition of *The Trauma of Birth*, Claude Girard points out that the position defended by Freud and his followers tended to exclude non-neurotic pathologies as legitimate objects of psychoanalytic exploration, whereas Rank's propositions encouraged the investigation of very early forms of pathology, along with that of the baby's earliest relations with its mother.

Both these avenues of inquiry were further explored subsequently by American psychoanalysts (Greenacre, 1945; Fodor, 1949; Alexander and French, 1946). More recently, Rank's main theme has been picked up with renewed vigor in the wake of object-relations theory, albeit without Rank's reductionism. Thus Wilfred R. Bion (1977) has used the term *caesura* in theorizing about the experience of a discontinuity in object-relations of which birth is the paradigm case. And Frances Tustin (1981) has described a premature psychological birth in autistic children corresponding to a consciousness of the bodily separation from the object that arises at a stage when the psyche is still unable to form symbols.

DIDIER HOUZEL

*See also:* Anaclysis; Anxiety as signal; Asthma; Birth; Castration complex; Cinema and psychoanalysis; Dream of birth; *Inhibitions, Symptoms and Anxiety*; *Lines of Advance in Psycho-Analytic Therapy*; Psychic causality; Psychoanalytic splits; Psychoanalytic technique (adults); Termination of psychoanalytic treatment; Trauma.

### Source Citation

Rank, Otto. (1924) *Das Trauma der Geburt und seine Bedeutung für die Psychoanalyse*. Leipzig/Vienna/Zurich: Internat. psychoanal. Verlag. English translation: *The Trauma of Birth*. London: Kegan Paul, Trench, Trubner, 1929; reprinted, with an introduction by E. James Lieberman, New York: Dover, 1993.

### Bibliography

- Alexander, Franz, and French, Thomas M. (1946). *Psychogenic factors in bronchial asthma*. Washington, DC: National Research Council.
- Bion, Wilfred R. (1977). *Two papers: The grid and caesura*. Rio de Janeiro: Imago Editora; reprint, London: Karnac, 1989.
- Fodor, N. (1949). *The search for the beloved: A clinical investigation of the trauma of birth and prenatal conditioning*. New York: Hermitage.
- Freud, Sigmund. (1900a). The interpretation of dreams. *SE*, 4–5.
- . (1926d [1925]). Inhibitions, symptoms and anxiety. *SE*, 20: 75–172.
- Greenacre, Phyllis. (1952). The biological economy of birth. In Greenacre, *Trauma, growth and personality*. New York: Norton. (Original work published 1945)
- Tustin, Frances. (1981) *Autistic states in children*. London: Routledge.

### Further Reading

- Mintz, I. L. (1975). Evolution of Otto Rank's theory of the birth trauma. *International Review of Psychoanalysis*, 2, 245–246.

---

## TRAUMATIC NEUROSIS

The term *traumatic neurosis* designates a psychopathological state characterized by various disturbances arising soon or long after an intense emotional shock. In the second half of the nineteenth century, a number of observations corresponding to a clinical picture of this kind were reported, typically in the wake of military action or railroad disasters, and related either to hysteria or to neurasthenia. Yet it was Hermann Oppenheimer who, in 1889, introduced the term itself into the lexicon of psychiatry.

Freud was to construct his theory of the neuroses on the model of traumatic neurosis. However, by stres-

sing the sexual character of the precipitating factor and the possibility that the action of traumatic neurosis could be deferred, rather than the fright occasioned by an accident's actual threat to life, he jettisoned what had hitherto constituted the specificity of the category. Furthermore, by taking into account predisposition for and tolerance of trauma, as well as the trauma's significance in the subject's history and mental organization, Freud relativized and reduced the notion of shock and its etiological import. The whole issue was destined to achieve its full immediacy only when historical events brought the war neuroses to the fore, prompting Freud to reconsider traumatic neurosis, first in 1916 in his *Introductory Lectures on Psychoanalysis* and once again in the context of his great theoretical revision of 1920.

For Freud, the economic point of view then became predominant. He accentuated the character of the trauma as at once somatic (the "disturbance" freed up the flow of excitations) and psychic ("fright"). In Freud's words, "The symptomatic picture presented by traumatic neurosis approaches that of hysteria in the wealth of its similar motor symptoms, but surpasses it as a rule in its strongly marked signs of subjective ailment . . . , as well as in the evidence it gives of a far more general enfeeblement and disturbance of the mental capacities" (1920g, p. 12).

Traumatic neurosis does not have the same meaning for psychoanalysts as it does for psychiatric clinical practice. The psychoanalytic characterization includes repetition: The patient relives the initial trauma, and this manifests itself in every situation, whether transference-related or not. The function of nightmares is to express the anxiety that was absent at the time of the original incident. Such repetitive manifestations reveal a fixation on the trauma as well as an attempt to discharge excessive tension in incremental fashion (that is, to work through it).

Clinically and theoretically, it is important to eschew the mistaken application of the term *traumatic neurosis* to the posttraumatic state (or syndrome), since *posttraumatic syndrome* refers to a physical (usually cranial) trauma and to disorders related to an emotional shock. Such states cannot in fact be brought under the heading of *neurosis* in a psychoanalytic sense. Here Freud himself ran into perplexities that led him to assign traumatic neuroses first to the class of the actual neuroses and then to that of the narcissistic neuroses. Traditional psychiatry, as reflected in the

third edition of *Diagnostic and Statistical Manual of Mental Disorders* (DSM-III), has renamed traumatic neurosis as "posttraumatic stress disorder," and while one might question its objectivizing use of *stress*, this approach does have the merits of avoiding the nosological trap of the neurosis/psychosis dichotomy and of viewing the issue from an interdisciplinary standpoint.

FRANÇOISE BRETTE

*See also:* Trauma.

### **Bibliography**

- Barrois, Claude. (1988). *Les névroses traumatiques*. Paris: Dunod.
- Ferenczi, Sándor, et al. (1921). *Psycho-analysis and the war neuroses*. Vienna: International Psycho-Analytical Press.
- Freud, Sigmund. (1916–1917a [1915–1917]). Introductory lectures on psycho-analysis. *SE*, 15–16.
- . (1920g). Beyond the pleasure principle. *SE*, 18: 1–64.
- Oppenheim, Hermann. (1889). *Die traumatischen Neurosen*. Berlin: A. Hirschwald.

### **Further Reading**

- Casoni, D. (2002). 'Never twice without thrice': Outline for traumatic neurosis. *International Journal of Psychoanalysis*, 83, 137–160.

---

## **TRUTH**

Sigmund Freud's notion of *truth* evolved from a factual conception into a relativistic method where the true and the false are defined both in relation to a conventional and bounded space (that of the cure) and the dynamic effects that "plausible" constructions might have on the psyche. Truth as an objective no longer remains "the fundamental rule of psychoanalysis" (1914g, pp. 147, 150). It inclines towards the notion of reality testing that demands that the subject partially abandon their illusions. Truth as an ideal is inseparable from psychoanalytic inquiry and is unattainable, except partially in the "nuclei" of truth present within individual and collective distortions.

The search for factors that cause psychic suffering can be confused with the search for truth inasmuch as they are both repressed, misrepresented, displaced, represented by their opposite, and the like. Initially Freud imagined rediscovering the traumatic events in the histories of his patients themselves, but promptly noticing “that there are no indications of reality in the unconscious, so that one cannot distinguish between the truth and fiction that is cathected with affect” (letter to Wilhelm Fleiss, 21 September 1897), he ended up privileging the psychical reality of the subject, wherein a dynamic verisimilitude was elaborated which would take on the value of truth. This relativization of truth seems to coincide with a Pirandellian conception of it (*Each in His Own Way*). In fact, truth as a value has not disappeared from the Freudian purview but it has become subtler. Thus interpretation is not about the exhumation of truth but rather construction through the adoption of a coherent paradigm (Viderman, 1970), originating from the unperceived formulations of the subject’s free associations or dreams.

Thus for Jacques Lacan, truth extricates itself from reality: “In psychoanalytic anamnesis, it is not a question of reality, but of truth, because the effect of full speech is to reorder past contingencies by conferring on them the sense of necessities to come” (1956, p. 48). Truth is not precisely being true to reality, rather it speaks and stutters through its symptomatic distortions.

The analyst has to engage with these “nuclei” of truth, then; Freud, for instance, defined them in relation to the sexual theories of children, which despite being untrue nonetheless each contain “a fragment of real truth” (1908c, p. 215). This is an adult, intellectual mode of investigation whose results, because they are limited to the possibilities of human understanding, would have been false in relation to a broader perspective, but which include nevertheless “inspired” partial but significant interpretations.

The quest for truth proceeds from a “truth fantasy” (Mijolla-Mellor, 1985), which relates to an image of lost harmony (transparency, luminosity) within the *I*, the others, and one’s self. Truth, in terms of the demand for truthfulness, is central to the fundamental rule that requires the abandonment of secrecy; however, it also guides the behavior of the analyst in their relationship with the patient, in their vision of the world, and in their research, requiring them to relin-

quish personal illusions for the construction of a coherent schema. Challenging illusion and narcissistic comfort, truth, according to Freud, is a force in its own right: “The hardest truths are heard and recognized at last, after the interests they have injured and the emotions they have roused have exhausted their fury” (1910d, p. 215).

Piera Aulagnier gives truth a central place in relation to the identity of the subject. It is the object of a “battle never definitively won nor lost to which periodically the *I* must surrender in order to modify and defend its positions, failing which it would be unable to turn towards or invest in its own identificatory space” (1984, p. 147).

The notion of truth in psychoanalysis is tied to the history the subject, in the same way as it is to humanity, because it is not simply a case of a balance between understanding and the thing, but of a narrative that is reconstructed using the residues left behind by legend.

ALAIN DE MIJOLLA

*See also:* History and psychoanalysis.

### **Bibliography**

- Aulagnier, Piera. (1984). *L'Apprenti-historien et le maître-sorcier. Du discours identifiant au discours délirant*. Paris: Presses Universitaires de France.
- . (1914g). Remembering, repeating and working-through (Further recommendations on the technique of psycho-analysis II). *SE*, 12: 145–156.
- Freud, Sigmund. (1908c). On the sexual theories of children. *SE*, 9: 205–226.
- . 1910d). The future prospects of psycho-analytic therapy. *SE*, 11: 139–151.
- . (1950a [1887–1902]). Extracts from the Fliess papers. *SE*, 1: 173–280.
- Lacan, Jacques. (1989). *Ecrits: A Selection*. (Alan Sheridan, Trans.) 5th ed. London: Tavistock/Routledge.

### **Further Reading**

- Reed, Gail S. (1995). Clinical truth and contemporary relativism: Meaning, narration. *Journal of the American Psychoanalytic Association*, 43, 713–740.
- Sass, L. A., and Woolfolk, R. L. (1988). Psychoanalysis and the hermeneutic turn: On “Narrative truth.” *Journal of the American Psychoanalytic Association*, 36, 429–454.



Schafer, Roy. (1992). Retelling a life. In *Narration and dialogue in psychoanalysis*. New York: Basic Books.

Spence, Donald. (1982). *Narrative truth and historical truth. Meaning and interpretation in psychoanalysis*. New York: W. W. Norton and Co.

Spezzano, Charles. (1993). A relational model of inquiry and truth: Conversation. *Psychoanalytic Dialogues*, 3, 177–208.

---

## TUBE-EGO

David Rosenfeld, the Argentinean psychoanalyst, introduced the notion of the “tube-ego” in an article written in 1981. Frances Tustin makes several references to it, particularly in chapter 10 of *Autistic Barriers in Neurotic Patients* (1986).

Based on convincing clinical material coming from adult patients, David Rosenfeld shows that in very regressive states they experienced their body image as a system of tubes controlling their bodily fluids. He suggests that this image of the body as a system of tubes seeming to contain the bodily fluids is more elementary than the image described in Esther Bick’s 1968 account of the skin as container.

Frances Tustin seems to agree when she says: “My own clinical work confirms that the body image as a system of pipes is more elementary than the image of the whole body being contained by the skin. However, the ‘system of pipes’ body image implies awareness of ‘insides,’ and also awareness of outside situations and identifications with them. It is a movement away from undifferentiated autism to a transitional awareness of ‘me’ and ‘not-me’” (1986, p. 228). She uses this concept not only to describe infantile autism but also to describe ancient levels of representation of the image of the body in relation to certain anorexic pathologies during adolescence.

Like Frances Tustin, Geneviève Haag in France also relies heavily on this concept in her work with autistic children.

BERNARD GOLSE

*See also:* Autism; Body image; Ego.

### **Bibliography**

Bick, Esther. (1968). The experience of the skin in early object relations. *International Journal of Psycho-Analysis*, 49, 558–566.

Rosenfeld, David D. (1981). *The notion of a psychotic body image in neurotic and psychotic patients*. Finland: Congrès psychanalytique international.

Tustin, Frances. (1986). *Autistic barriers in neurotic patients*. London: Karnac Books.

---

## TURNING AROUND

Turning around is a process that affects the vicissitudes of the instinct in terms of its affective expression (for example, love turning into hate), its aim (for example, active turning into passive), or its object (in particular, the shift from being directed toward another person to being turned back onto the self). These three types of processes are closely related.

Freud gave his essential description of this dynamic in “Instincts and Their Vicissitudes” (1915c). He defined four vicissitudes of the instincts: repression, sublimation, reversal into the opposite, and turning around upon the subject’s own self.

Freud also used the term *reversal* in this article in a different sense involving the transformation of psychic “contents,” that is, an idea, a representation, a dream image, a symptom, or the like, into its opposite. With regard to the instinct itself, or rather its expression as an affect, this dynamic “is found in the single instance of the transformation of love into hate” (1915c, p. 127); moreover, these two affects can coexist, which is the definition of ambivalence. However, it is appropriate to nuance Freud’s statement here, because reversal in the opposite direction, from hate into love, can also occur through reaction formation.

In the same article, Freud discusses two types of turning around onto the self: sadism turning into masochism and voyeurism turning into exhibitionism. The former involves the transformation of sadism (the pleasure of violence being directed toward another person) into masochism (the subject derives pleasure from violence being directed against himself or herself and solicits it from someone else). In this 1915 article, Freud posited sadism as being primary and masochism as being secondary, that is, resulting from turning around, which necessarily implies a reversal inversion of agent and object positions (the relationship in which the subject directs aggression against another person turns into one where the other person directs aggression against the subject) and a reversal inversion

of the aim (the active aim, to direct aggression against the other, becomes passive, to be the object of the other's aggression). Previously, in "Formulations on the Two Principles of Mental Functioning" (1911b), Freud had upheld that at the beginning of life only the pleasure principle holds sway; the instinct knows only autoerotic satisfaction. During the narcissistic phase, the nascent ego, once it begins to distinguish between inside and outside, takes into itself from the outside that which is pleasurable and expels that which is painful, thus constituting itself as "purified pleasure-ego" (1915c, p. 136). As a result, "the external world, objects and what is hated are identical" (p. 136); the object is born in hatred. As we know, this was to become the basis for the theories of Melanie Klein. However, this thesis, which lacks clarity, seemed somewhat forced even to Freud himself. In "The Economic Problem of Masochism" (1924c), he reconsidered this trajectory and proposed to reverse it, by positing masochism as being primary and sadism as being secondarily produced through turning around and projection onto the external object. (These issues have been discussed, in particular, by Benno Rosenberg in *Masochisme mortifère et Masochisme gardien de la vie* (1991; Destructive masochism and masochism as preserver of life.)

Whatever the case may be, the dynamic of suppressing aggressive impulses and turning them against the self and a transformation with regard to the aim of the instinct, which changes from active to passive (the instinct itself, we must recall, is always active) is routinely encountered in clinical practice.

The same is true of the reversal of voyeurism into exhibitionism. Here Freud distinguished three "stages" corresponding to the successive modes of the search for pleasure: looking at the body of another person, looking at one's own body, and displaying one's body so that it will be looked at. Here again, the change from active aim to passive aim and turning around onto the self are closely linked, and the narcissistic phase plays an essential role in this developmental process.

In clinical terms "the turning round upon the subject's self and the transformation from activity to passivity converge or coincide" (1915c, p. 127). It nevertheless remains useful, on a theoretical level, to distinguish these modalities which is what André Green does, notably, in *Life Narcissism, Death Narcissism* (1983/2001) has proposed with the idea of "a double return."

To these two types of turning around analyzed by Freud (sadism-masochism and voyeurism-exhibitionism), it would be possible to add the opposition he defined during the same period between ego libido and object libido, or, in terms of cathexis, between the ego's cathexis of the object or of itself. This opposition, described in "On Narcissism: An Introduction" (1914c), is within the context of the first theory of the instincts (opposition between the sexual instincts and the self-preservation or ego instincts). Freud later revisited this opposition in light of his topographical and economic theories of the 1920s, in particular within the framework of his thinking on the psychoses. However, throughout these successive versions, these same figures of turning around appear, with regard to affect (love-hate), the instinctual aim (active-passive), and the object (self-other).

ROGER PERRON

*See also:* Reversal.

### **Bibliography**

- Freud, Anna. (1936). *The ego and the mechanisms of defence*. London: Hogarth.
- Freud, Sigmund. (1911b). Formulations on the two principles of mental functioning. *SE*, 12: 213–26.
- . (1915c). Instincts and their vicissitudes. *SE*, 14: 109–40.
- Green, André. (2001). *Life narcissism, death narcissism* (Andrew Weller, Trans.). London and New York: Free Association Books. (Original work published 1983)
- Rosenberg, Benno. (1991). *Masochisme mortifère, Masochisme gardien de la vie*. Paris: Presses Universitaires de France.

---

## **TURNING AROUND UPON THE SUBJECT'S OWN SELF**

The notion of *turning around upon the subject's own self* refers to the process that substitutes the subject's own self in place of the external object of an instinct. This term appeared in Sigmund Freud's writings in "Instincts and Their Vicissitudes" (1915c), where it is discussed as one of the four vicissitudes of the instincts: repression, sublimation, reversal into the opposite, or "turning round upon the subject's own self" (p. 126). Freud described this latter process as

being closely linked to reversal into the opposite and used the study of two clinical models to understand its effects: sadism-masochism and voyeurism-exhibitionism.

In sadism there is a manifestation of aggression toward another person, who is treated as an object. If the object of the instinct becomes the subject's own self, the initial instinctual aim simultaneously changes from active to passive, because the sadism is then directed against the subject. Turning against the self is demonstrably at work even though the subject has not yet subjugated himself to another person. Obsessional neurosis is representative of this intermediary stage, which Freud described as self-punitive rather than masochistic. A final stage consists in the search for another person to play the active role that the subject renounces, thereby submitting to masochistic control. One can see how, over the entire trajectory from sadism to masochism, turning around upon the subject's own self occurs alongside the transformation of activity into passivity, in this inversion of roles between the person who exercises sadism and the person subjected to it.

Another pair of opposites, voyeurism-exhibitionism, provides a clear example of the same mechanisms. The three successive stages played out in the previous example can be found again here. Thus, there is initially "looking" as an activity that the subject directs against an unknown object, followed by the subject's submission to a turning around of the scopical drive onto a part of his or her own body. Finally, the introduction of a third element allows the subject to become the object of another person's gaze.

Freud emphasized that these operations as a whole do not exhaust all the energy of the instinct and that once again, the psyche prefers to work upon small quantities of energy. Moreover, it seems that the three stages previously described as unfolding in a linear fashion are in fact all present in varying degrees and that they develop in conjunction with one another.

Anna Freud included turning against the self in the list of defense mechanisms enlisted by the ego in its struggle against guilt-inducing instinctual impulses. In *The Ego and the Mechanisms of Defense* (1936), she cited this process as one of the most primitive ones, "as old as the conflict between the instinctual impulses and whatever obstacle may be erected against them." However, she revised her attempt to chronologically situate this defense mechanism, as well as others, for lack of confirmation during her clinical work. Thus, in

terms of the mechanism in question, she acknowledged the rarity, in very young children, of true masochistic manifestations resulting from a turning around of the instinct back onto the self.

In the psychoanalytic literature, this notion is at the crossroads of numerous avenues of thought. Freud, for example, let it be understood that the manifestation of the instinctual vicissitude described here depended on the subject's narcissistic organization.

JEAN-BAPTISTE DÉTHIEUX

*See also:* Drive/instinct; Identification with the aggressor; "Instincts and their Vicissitudes"; Reversal into the opposite; Self-hatred; Turning around.

### **Bibliography**

Freud, Anna. (1936). *The ego and the mechanisms of defence*. London: Hogarth; New York: International Universities Press.

Freud, Sigmund. (1915c). Instincts and their vicissitudes. *SE*, 14: 109–140.

### **Further Reading**

Davison, W., Bristol, C., and Pray, M. (1986). Turning aggression on the self: Study of psychoanalytic process. *Psychoanalytic Quarterly*, 55, 273–295.

Levin, Fred M. rep. (1990). Panel: Sadism and masochism in neurosis and symptom formation. *Journal of the American Psychoanalytic Association*, 38, 789–804.

---

## **TUSTIN, FRANCES (1913–1994)**

Child analyst Frances Tustin was born on October 15, 1913, in Darlington, northern England, and died on November 11, 1994, outside of London. She was the only child of parents who separated in 1926. Traumatic memories of this separation remained with her, especially because she had been very close to her father and would not see him again for some fifteen years. Married for the first time in 1938, she divorced in 1946, and two years later she married Professor Arnold Tustin, an eminent physician who took a close interest in her work and greatly encouraged her in her research. She at first focused on the teaching profession and worked in that field for several years.

In 1943 she had the opportunity to attend courses in child development taught by the Kleinian psychoanalyst Susan Isaacs at the University of London. She was fascinated by this approach to children, which was entirely new to her. Six years later, in 1949, after the death of her first baby, she felt a calling to become a child psychotherapist. She learned of a nascent training program at the Tavistock Clinic and enrolled. As a part of her training, she had to enter into analysis with Wilfred Bion. She decided to end her analysis after fourteen years (with two interruptions, once for an internship in the United States and once for her second pregnancy, which ended, yet again, in the death of the baby at birth). After stopping treatment, she was beset with terrors, which she later understood as an expression of autistic anxieties. Because Bion had returned to the United States, she had to call upon another analyst, Stanley Leigh.

At the Tavistock Clinic, Tustin first heard about autistic children by way of a lecture given by Marion Putnam at the invitation of the clinic's then director John Bowlby. She was fascinated by what she heard. In 1953, her husband having accepted a one-year appointment as visiting associate professor in the United States, she had the opportunity of doing an internship at the James Putnam Center in Boston, one of the first treatment centers for autistic children. Back in London she wanted to apply the Kleinian method of analysis to autistic children. She soon realized that Melanie Klein's theories had to be expanded to account for this new pathology.

Her treatment of her first autistic patient revealed to her the anxiety that is at the heart of this disorder and that is due to the trauma associated with the emerging awareness of bodily separation from the object at a stage when the ego cannot yet form symbols. The child feels as if it were experiencing not just loss of the object but also the sensation of being bodily uprooted. She showed that this uprooted feeling is usually localized in the mouth. It is as if the autistic child felt brutally exposed to a series of discontinuities along the mouth-tongue-nipple-breast axis. These discontinuities not only lead to loss of the illusion of controlling the object of instinctual satisfaction, but also give the child the intolerable anxiety of feeling amputated, emptied, and annihilated, and of feeling that the object too is amputated and emptied. The child then erects defense mechanisms against the anxiety of this traumatic experience. These defense mechanisms consist

of autistic forms (impressions that the autistic subject procures for itself with its own bodily secretions, stereotyped movements, or interoceptive sensations), autistic objects (concrete objects that the child manipulates not for their conventional uses or their symbolic values, but rather for the sensations that they cause against the skin or the mucous membranes, and that procure autistic forms), and the autistic shell (a world of pure sensations made of up autistic forms and objects, without otherness; a two-dimensional world in which the only possible relationship is an adhesive one of "sticking").

Tustin's work broadened and updated the understanding of childhood autism and made possible an effective therapeutic approach to it, but her influence went beyond the realm of autism itself. In effect, she described autistic pockets or barriers present in personalities affected by various disorders: phobias, melancholia, mental anorexia, psychopathy, psychosomatic pathologies, and severe childhood functional disorders (enuresis, encopresia). These autistic pockets are parts of a personality caught in a system of autistic defenses, and they must be analyzed to avoid interminable analyses and negative therapeutic reactions.

An honorary member of the British Psychoanalytical Society, Tustin taught at the Tavistock Clinic, where she trained many students. In addition, many child psychotherapists and psychoanalysts from around the world went to London, and later to Amer-sham, in the greater London suburbs, where she lived at the end of her life, to benefit from her supervision. She was invited to deliver lectures in numerous European countries and in the United States. She published some thirty articles and four books. In addition, there are videos recordings of three interviews with Tustin. Nearly all of her publications and research focused on childhood autism. From her first contact with children afflicted with this disorder at the beginning of the 1950s until her death, she continuously strove to promote deeper understanding and better treatment of this condition.

DIDIER HOUZEL

*Notions developed:* Autistic capsule/nucleus; Black hole.

*See also:* Autism; Autistic defenses; Breakdown; Dismantling; Infantile psychosis; Lack of differentiation; Psychic envelopes; Self-mutilation in children; Sucking/thumb-sucking; *Trauma of Birth, The*; Tube-ego.

### Bibliography

- Spensley, Sheila. (1995). *Frances Tustin*. London: Routledge.
- Tustin, Frances. (1972). *Autism and childhood psychosis*. London: Hogarth.
- . (1981). *Autistic states in children*. London: Routledge.
- . (1986). *Autistic barriers in neurotic patients*. London: Karnac Books.
- . (1990). *The protective shell in children and adults*. London: Karnac Books.

---

## TWINSHIP TRANSFERENCE/ALTER EGO TRANSFERENCE

Twinship or alter ego transference is a form of narcissistic transference defined by Heinz Kohut as expressing the analysand's need to rely on the analyst as a narcissistic function possessing characteristics like herself.

Kohut first defined the concept in *The Analysis of the Self* (1971) as one of the possible forms of mirror transference. In *How Does Analysis Cure?* (1984) he made alter ego transference a type of transference unto itself, corresponding to the existence of an autonomous narcissistic need, the alter ego.

It is often in relation to the analyst being experienced as identical or similar that narcissistic tendencies are pinpointed. Kohut believed that oedipal interpretations are often understood by patients as being a repetition of the parents' negation of narcissistic needs, which means that such interpretations are premature. Interpretation of the narcissistic needs of the alter ego, when it is appropriate, causes memories to emerge that can be worked through.

Alter ego transference relates to mirroring and idealizing narcissistic transference, to the grandiose self, and to the idealized parental imago. This conceptualization has been criticized both in terms of narcissistic transferences and the priority given to narcissism over instinctual conflicts, and as an attempt to replace Freudian metapsychology with a metapsychology of the self, understood as being made up of sectors.

AGNÈS OPPENHEIMER

See also: Alter ego.

### Bibliography

- Kohut, Heinz. (1971). *The analysis of the self*. New York: International University Press.
- . (1984). *How does analysis cure?* Chicago: University of Chicago Press.

### Further Reading

- Burlingham, Dorothy T. (1946). Twins. *Psychoanalytic Study of the Child*, 2, 61–74.
- Gorney, J. (1998). Twinship, vitality, pleasure. *Progress in Self Psychology*, 14, 85–106.
- Simon, Bennett. (1988). The imaginary twins: The case of Beckett and Bion. *International Review of Psychoanalysis*, 15, 331–352.

---

## TYPICAL DREAMS

A typical dream is a dream that, in its content and form, is very much alike for a great many people. Freud devoted a long section to typical dreams in *The Interpretation of Dreams* (1900a): these are “dreams which almost everyone has dreamt alike and which we are accustomed to assume must have the same meaning for everyone” (p. 241).

These dreams could be considered to be an exception to the rule that the meaning of a dream can only be deciphered through the dreamer's own interpretation; furthermore, Freud added, associations connected with such dreams are in general weak and vague. He was interested primarily in four kinds of typical dream.

- dreams of nudity, gratifying an exhibitionist desire dating from childhood;
- dreams of the death of loved ones, of which there are two varieties: death of a brother or a sister, an expression of infantile jealousy, and death of a parent, the direct expression of oedipal hatred for a parent of the same sex (it was in this passage that Freud gave for the first time a closely reasoned description of that which he later was to call the *Oedipus complex*). Any dream of the death of a loved person would therefore be an

expression of a death wish, Freud commenting that in this case, contrary to what has been observed in most dreams, the result of the wish—disguised as a fear—is represented without displacement: it really is the death of the loved person that is represented. Freud specified that in these dreams of infantile satisfaction, death does not have the meaning it has for the adult; it is simply absence, which is why the dream is often not very painful;

- dreams of flying. A note added in 1925 suggested that this could be a representation of the primal scene (sexual rapports between parents);
- dreams of being obliged to retake an examination, as an adult, that has been taken and passed successfully at a younger age. The meaning of this is frequently reassurance before a difficult moment (“you have passed this examination before, therefore you will succeed again . .”).

Freud returned to this subject later in the same book, where he maintained that typical dreams deploy symbolic representations rooted in the culture and found in tales, folklore, and myths: “the question is bound to arise of whether many of these symbols do not occur with a permanently fixed meaning, like the ‘grammalogues’ in shorthand” (p. 351). Yet, in most cases, something personal to the dreamer is added to the “universal” symbol. Freud illustrated this proposition with a great number of examples of dreams of stairways, tooth extractions, theft, birth, etc., where, however, this distinction seems to be a little vague.

Thereafter, the subject of typical dreams did not come up much in Freud’s work. It has been discussed by Denise Braunschweig and Michel Fain (1975) from the perspective of castration, these kinds of dreams appearing to them to bear witness to a “hysterical kernel,” which they describe as “a capacity to turn something into its opposite, so creating a double meaning susceptible of satisfying the demands of bisexuality.”

ROGER PERRON

*See also:* Death (representation of) in psychoanalysis; Dream; Dream of birth; Dream of mourning; Dream of nakedness; “Dream of the wise baby, The”; Dream symbolism; Examination dreams; *Myth of the Birth of the Hero, The*; Silence.

### **Bibliography**

Braunschweig, Denise and Michel Fain. (1975). *La nuit, le jour. Essai psychanalytique sur le fonctionnement mental* [Night and day: psychoanalytical essay on mental functioning]. Paris: Presses Universitaires de France.

Freud, Sigmund. (1900a). The interpretation of dreams. *SE*, 4–5.

### **Further Reading**

Myers, Wayne A. (1989). The traumatic element in the typical dream of feeling embarrassed at being naked. *Journal of the American Psychoanalytic Association*, 37, 117–130.

Renik, Owen. (1981). Typical examination dreams, “super-ego dreams” and traumatic dreams. *Psychoanalytic Quarterly*, 50, 159–189.





## ULCERATIVE COLITIS

Organic in its etiology, ulcerative colitis remains an enigmatic disease, although current understanding puts it in the group of autoimmune disorders, thus increasing its interest for those involved in psychosomatic medicine.

It involves continuous damage to the mucous lining of the colon but can also affect the rectal mucosa. The latter are eroded, sometimes abscessed, and can rupture, making this a serious condition. It progresses through a series of attacks of varying degrees of severity and can occasionally necessitate a colectomy with a colostomy.

Its main symptom, bleeding (the mucosa “weep” blood), the psychological profile often associated with it (depression, regression), and its evolution, which is variable and unpredictable but is often correlated with a psychoaffective trauma, have put this disease under the spotlight among psychoanalysts specializing in psychosomatic disorders.

The circumstances that trigger the onset of the disease or attacks have been identified by the majority of authors. These appear to be fortuitous during the early stages of investigation but may become more defined in the course of psychotherapy with the gradual emergence of latent content. Often, although not always, the following are found: experiences of object-loss, experiences of wounded narcissism with feelings of worthlessness, self-depreciation, and a sense of the impossibility of taking on new responsibilities. These experiences may result from new real-life situations (with a traumatic valence) or situations that are fantasized and retroactively reconstructed. In “Étude psy-

chosomatique de dix-huit cas de recto-colite hémorragique” (Psychoanalytic study of eighteen cases of ulcerative colitis; 1958), Michel de M’Uzan and his collaborators wrote: “The common element in these factors is their ability to provoke in the patient a loss of self-esteem, along with the belief that he is unloved or incapable of overcoming a difficulty.”

Thus, to a greater degree than with other organic pathologies, these causes point toward a narcissistic destabilization along with a certain degree of melancholia. Inspired by the bleeding mucosa, certain authors have speculated a “melancholia of the organ”—a theoretical fantasy on the part of the analyst or a structural reality?

The fact remains that a somewhat mechanistic approach would posit the existence of: an affective block or immaturity; strong ambivalence (the depressive pole of which is deeply repressed) toward persons close to the patient as well as toward the therapist; and a depressive tendency different from the reactive depression of the disorder. This depression, sometimes carried along on the tide of a massive regression, has even led to indications for treatment with antidepressants (see Guy Besançon’s article “Le corps présent, réflexions sur une série de recto-colites hémorragiques” [The body as presence; reflections on a series of cases of ulcerative colitis]; 1977).

This correlation between ulcerative colitis and a narcissistic axis of depression remains a pivotal element in attempts at a psychoanalytic interpretation. Some authors have thus invoked the idea of a somatic dramatization of melancholia and have sought its source in the mother-child relationship, thereby suggesting that this disorder may be part of a psychogenetic given.



Kleinians see this disease in terms of incorporation of a bad maternal imago: According to Melitta Sperling (1946), “As the object is incorporated sadistically, it is a hostile inner danger and has to be eliminated immediately. The faeces and blood (in severe attacks, only blood and mucus) represent the devaluated and dangerous objects.... The severe form of ulcerative colitis shows a great resemblance in behavior, personality structure and dynamics to melancholia, and seems to represent the somatic dramatization of the same conflict, with relatively little mental pain, that in depression is expressed psychologically” (p. 326).

There is no consensus on this approach. However, it seems probable that these patients have been unable to constitute and develop a mental space wherein they could find themselves by finding objects other than the primary object to which they felt and feel extremely bound, in an inexorable and often conflicted way.

See also: Psychosomatics.

### Bibliography

- Besançon, Guy. (1977). Le corps présent, réflexions sur une série de recto-colites hémorragiques. *Revue française de psychosomatique*, 19 (2).
- Caïn, Jacques, R. Sarles, and F. Berretti. (1984). Aspects psychosomatiques de la recto-colite hémorragique. *Encéphale*, 44.
- Fine, Alain. (1984). Quelques réflexions et interrogations autour de la recto-colite hémorragique. In M. Fain and C. Dejours (Eds.), *Corps malade et Corps érotique* (pp. 59–76). Paris: Masson.
- Sperling, Melitta. (1946). Psychoanalytic study of ulcerative colitis in children. *Psychoanalytic Quarterly*, 15 (3), 302–329.
- M’Uzan, Michel de, S. Bonfils, and A. Lambling. Étude psychosomatique de dix-huit cas de recto-colite hémorragique. *Semaine des Hôpitaux de Paris*, 34 (15), 1–7.

### Further Reading

- Cushing, M. (1953). Psychoanalytic treatment of man with ulcerative colitis. *Journal of the American Psychoanalytic Association*, 1, 510–518.
- Lefebvre, P. (1988). The psychoanalysis of a patient with ulcerative colitis. *International Journal of Psychoanalysis*, 69, 43–54.
- Sperling, Melitta. (1957). The psychoanalytic treatment of ulcerative colitis. *International Journal of Psychoanalysis*, 38, 341–349.

## UNARY TRAIT

According to Jacques Lacan, the unary trait is the elementary form of the signifier as pure difference that supports symbolic identification.

In the second of the three forms of identification described by Freud, the subject identifies regressively with a love object or rival by adopting a “single trait” of the other person (*einzigiger Zug*) (1921c, p. 107). Dora’s cough, for example, was an imitation of her father’s.

Lacan recognized this single trait as a signifier. Or more precisely, insofar as this signifier is isolated and is not part of a chain of signifiers, it is first a sign or an “insignia of the Other” (cf. Lacan, 1957–58, p. 304; 2002, p. 253). This insignia of the Other constitutes the nucleus of the ego-ideal.

In his seminar on *Identification* (1961–62), Lacan used Saussure’s linguistics, to compare the *einzigiger Zug* with the signifier as a distinct element. Thus he translated it as “unary trait” to emphasize its mathematical sense, comparing it with a binary number.

Ferdinand de Saussure defined the signifier negatively. It is not the same, but is different from the other signifiers in a given structure. This implies that a signifier is also different from itself. This pure difference characterizes the unary trait. As an example of the first primitive indication of the existence of the signifier, Lacan referred to a prehistoric hunter carving notches into a piece of bone. One notch signifies each kill, with no reference to the different types of prey or the particular events of each hunt. Each animal killed counts as one, and that is the only aspect of the hunt marked by the trait.

Of course, the traits in a series need not resemble each other. They do not need to be identical in order to be the same. In fact, the contrary is true. Because no simple trait is recognizable as a thing itself, once it becomes part of a series you cannot tell which was the first mark.

When the thing is erased, the unary trait remains as symbolic of its absence. Thus the trait transforms the absent thing into an object of desire. A second mark, indistinguishable from the first, creates a hole in which this object is lost. Thus the unary trait merges with the phallic mark and the castration threat, insofar as it forever prohibits access to the incestuous Thing. The existence of the subject of the enunciation is suspended by the trait that names it, but this subject immediately

disappears in the trait that fixes it, such that the subject only exists between two traits.

To formalize the unary trait, Lacan relied on the topology of the torus, insofar as the unary trait is the mark of a double loss, the loss of an object, which corresponds to the central hole of the torus, and the absence of the subject of the unconscious, which is the uncounted turn of the repeated demand. A single cut that makes a Möbius strip, where the two surfaces are one, corresponds to the structure of the unary trait, identical neither to itself nor to the structure of the subject.

MARC DARMON

See also: Identification; Imaginary identification/symbolic identification; *Infans*; Topology.

### Bibliography

- Freud, Sigmund. (1921c). *Group psychology and the analysis of the ego*. *SE*, 18: 65–143.
- Lacan, Jacques. (1958). The direction of the treatment and the principles of its power. In Bruce Fink (Trans.), *Écrits: A selection*. New York: W. W. Norton, 2002.
- . (1964). *The four fundamental concepts of psychoanalysis* (Alan Sheridan, Trans.). New York: W. W. Norton, 1978.
- . (1957–58). *Le Séminaire-Livre V, Les Formations de l’Inconscient*. Paris: Seuil, 1998.
- . (1961–62). *Le Séminaire-Livre IX, L’identification* (unpublished seminar).

---

## “‘UNCANNY,’ THE”

When Sigmund Freud’s essay “The Uncanny” appeared in 1919, he had already made a reference to the *Unheimliche*, in *Totem and Taboo* (1912–1913a), as well as bringing up the “omnipotence of thought.” This shows that the question had interested Freud for some time. Here there are passages on repetition compulsion as well that foreshadow *Beyond the Pleasure Principle*, which was published a year later (1920g). A forum for intersecting propositions, the essay is also a compendium of references (Ernst Jentsch, Friedrich von Schiller, Ernst Theodor Amadeus Hoffmann) and yet, Freud does not reference the psychoanalytic literature on related topics, such as Pierre Janet’s déjà-vu, or Joseph Capgras’s illusion of the double.

To establish his evasive concept, Freud follows two approaches at the same time: etymology and linguistic variants, and observations or fantasies that appear in novels. The French, English, and Spanish translations of *unheimlich* all fail to recapitulate the principal reference to the familiar, or family (*heim*, or home), which defines and limits the notion of the uncanny.

*Das Unheimliche* is defined as “that particular variety of terror that relates to what has been known for a long time, has been familiar for a long time.” We are presented at once with a paradox that Freud does nothing to alleviate since the familiar should not be disquieting. This proposition is at the heart of Freud’s ideas about the original pleasure-ego that coincides with the good and rejects the bad. In “Instincts and their Vicissitudes” (1915c), we find the same opposition between ego/non-ego, just as we do in “Negation” (1925h). Still, it is not clear why the familiar should be threatening and therefore, a second element is needed, namely, the secret, the hidden, which gives rise to the notion of hostility and danger. For danger is associated with penetrating what is sealed off, and strangeness—based on an idea Freud borrowed from von Schilling—with the revelation of what should by rights remain hidden because it is the bearer of transgression.

To these linguistic and fantasy associations, Freud, in the second part of the essay, introduces a number of literary examples (many from Hoffmann), centered primarily on the intellectual uncertainty over whether something is living or not (from Jentsch). There it is shown how the repetition compulsion manifests itself through the return of the repressed. This is true even in situations where we expect the new and with it the return of the dead to life.

The theme of the double, developed by Otto Rank, whom Freud quotes, is a source of ambivalence: the assurance of survival and a harbinger of death. Consequently, the *Unheimliche* is connected with the anxiety associated with the return of the repressed and with this the concept receives considerable scope: “With animism, magic, sorcery, the omnipotence of thought, unintentional repetition, and the castration complex, we have for the most part examined all the factors that transform anxiety into the uncanny.”

This essay is certainly one of the most fecund, if not one of the most confused, written by Freud. It represents an exemplary effort at combining literature and psychoanalysis, for Freud helps establish his thesis on the basis

of the study of works of literature. The concepts of anxiety associated with the foreign (René Spitz) and the secret (Piera Aulagnier) have been the subject of research that does not directly extend Freud's work. However, examination of the supernatural (telepathy, for example) and the analysis of literature based on the "anxiety of fiction" (Mijolla-Mellor) are directly related to Freud's study of the uncanny.

SOPHIE DE MIJOLLA-MELLOR

*See also:* Double, the; Fear.

### Source Citation

Freud, Sigmund. (1919h). Das Unheimliche. *Imago*, 5: 297–324; *GW*, 12: 229–268; The "uncanny," *SE*, 17: 217–256.

### Bibliography

- Freud, Sigmund. (1912–1913a). Totem and taboo. *SE*, 13: 1–161.
- Rank, Otto. (1914). *The double: A psychoanalytic study*. Chapel Hill: University of North Carolina, 1971.

## UNCONSCIOUS AS INFINITE SETS: AN ESSAY IN BI-LOGIC, THE

In *The Unconscious as Infinite Sets: An Essay in Bi-Logic*, a major work published in 1975, Ignacio Matte-Blanco introduced an important modification of Freud's notion of the unconscious. His purpose was to save the notion from being progressively forgotten in contemporary psychoanalytic developments. The author refused to consider the unconscious as chaotic (Freud, 1933a [1932]). If a characteristic form of functioning, like the primary process (the processes of the id), may be described as belonging to the unconscious system, then, he thought, one can discover a different organization for it than the one ruling the conscious system. Grounded in this idea, Matte-Blanco studied the logical principles that would allow systematic unconscious violations of classical, asymmetric logic, the basis of consciousness.

Unconscious logic rises from two principles: the principle of generalization and the principle of symmetry. The principle of generalization, also present in classical logic, postulates that in the unconscious each

entity is treated as part of a set with other elements, this set being treated in turn as a subset of a greater set, and so forth. Entities are distinguished one from the other and grouped together again through abstraction of their similarities. The second principle is that in the unconscious, asymmetrical relations are selectively treated as if they were symmetrical (Rayner, 1995), with the result that relations of succession and contiguity, like time and three-dimensional space, disappear. A part can equal the whole, and similarities can be transformed into identities.

The unconscious is conceptualized as an aggregate of infinite sets. According to the definition of the mathematician Richard Dedekind (1831–1916), infinite sets are those in which a specific subset, for example, the even numbers, can be placed in a one-to-one correspondence with the whole set—for example, the set of natural numbers. The part is equal to the whole.

Symmetrical logic is the expression of a symmetrical system, according to which reality is a homogenous and indivisible whole. Asymmetrical logic is the manifestation of an asymmetrical system, where reality divides into parts. In states of intense emotion, the experience and logic of the symmetrical system are dominant, so for the mind, the emotional object is infinite and is also part of an infinite set.

Matte-Blanco succeeded in formalizing (or mathematizing) the study of the unconscious. He discovered a startling isomorphism among the emotional, the unconscious, and infinite logic (Bria and Durst, 1992).

JUAN FRANCISCO JORDAN MOORE

*See also:* Id; Logic(s); Matte-Blanco, Ignacio.

### Source Citation

Matte-Blanco, Ignacio. (1975). *The unconscious as infinite sets: An essay in bi-logic*. London: Duckworth.

### Bibliography

- Bria, Pietro, and Durst, Margarete. (1992). Ignacio Matte-Blanco (Portrait). In A. Negri (Ed.), *Novecento filosofico e scientifico. Protagonisti* (Vol. 3, pp. 409–443). Marzorati: Milano.
- Freud, Sigmund. (1933a [1932]). *New introductory lectures on psycho-analysis*. *SE*, 22: 1–182.
- Rayner, Eric. (1995). *Unconscious logic: An introduction to Matte Blanco's bi-logic and its uses*. London: Routledge.

## UNCONSCIOUS CONCEPT

Freud defined the term *unconscious concept* in “From the History of an Infantile Neurosis”: “Feces, ‘baby’ and ‘penis’ thus form a unity, an unconscious concept (*sit venia verbo*)—the concept, namely, of ‘a little one’ [*une petite choses*] that can be separated from one’s body” (1918b [1914], p. 84).

In philosophy, a concept is an idea that is abstract and susceptible to generalization and that allows for the apprehension of content *a priori* (Kant). It also refers to the grouping of objects of experience into classes. It is this latter, empirical aspect that Freud retains, since it is the equivalence of objects within a certain relationship that allows him to speak of a concept. The notion presented by Freud is complicated by the fact that the concepts under discussion are “unconscious.” In other words, they are not the result of a process of judgment.

Unconscious concepts as defined by Freud come very close to the notion of symbolic equivalence, which is fundamental to the symptom. They also illustrate the unconscious origin of thought in its connections with (anal) sensation and the related fantasy elaboration that arises from it.

SOPHIE DE MIJOLLA-MELLOR

*See also:* Demand; Feces; Infantile psychosis; Phallus; Phallic stage; Symbolic equation; Symbolism; Symbolization, process of.

### Bibliography

Sigmund, Freud. (1918b [1914]). From the history of an infantile neurosis. *SE*, 17: 1–122.

Mijolla-Mellor, Sophie de. (1992). *Le plaisir de pensée*. Paris: Presses Universitaires de France.

Neyraut, Michel. (1978). *Les logiques de l’inconscient*. Paris: Hachette.

## UNCONSCIOUS FANTASY

Kleinian psychoanalysts regard the unconscious as made up of fantasies of relations with objects. These fantasies are the mental representation of instincts, and hence are thought of as primary (Isaacs, 1948).

When Freud (1900a) stressed the psychological meaning of childhood trauma, rather than its reality, he moved from a physiological way of thinking to a psychological one, thereby giving priority to the internal world. His paradigm of the psychological world was the unconscious fantasy of the three-person constellation that he named the *Oedipus complex*. Freud contrasted such internal libidinal fantasizing (the Oedipus complex) with the desexualized fantasy that serves as the basis for launching new sorts of sublimated activity in a wide domain. The role of fantasy in sublimating libido in such activities as daydreaming and aesthetic creation is quite different from the primary unconscious fantasies that provoke the conflicts of the early Oedipus complex.

Suzan Isaacs (1948) defined unconscious fantasy as the mental representation of instinct. In other words, the libido, from the outset, is an activity of mind, despite its physiological origins and functions. It takes the form of a fantasy of performing an (oral, anal, or genital) activity with an object. On the basis of such fantasies as the raw expression of instinct, the primitive mind of the infant can start to reorder itself through further primitive fantasies of projection, introjection, splitting, and denial, and in this way it may relieve itself of the experiences and terrors of primitive conflicts.

One developmental sequence starts with the unconscious fantasies of the Oedipus complex in its early stages and evolves, through fear (for example, castration anxiety), into a desexualized form: daydreaming (Freud, 1919e). Daydreaming, expressed by children in their relentless playing (Freud, 1908c), is an important activity. Classical psychoanalysis emphasizes daydreaming and its sublimatory opportunities, while Kleinian psychoanalysis emphasizes the roots of fantasy life in the unconscious.

Child analysis as developed by Melanie Klein (1955) demonstrated the workings of the unconscious in the fantasies of play. Klein developed her technique on the basis of how figures are repositioned in play. This led to a theory of how objects are positioned in relation to each other and to the child’s self. Klein recognized in the details of play the child’s defensiveness as well as the child’s primary and conflicting impulses. The unconscious roots of impulses and defenses are expressed in relations with objects.

The nature of the very early primary fantasies was hotly debated. Anna Freud disputed Melanie Klein’s claim that the infant has coherent fantasies from such an early age. She regarded the unconscious fantasies

that Klein and her colleagues reported as secondary elaboration at later stages of development. For Anna Freud, the infant develops cognitively by establishing representations of reality and the objects in it, but these representations do not cohere into meaningful, motivating fantasies until after phases of autoeroticism and primary narcissism. Jean Piaget (1954) and Margaret Mahler et al. (1975) have plotted the emergence of representations of reality from these early objectless phases. Other infant psychologists, such as Daniel Stern (1985), tend to see the infant as possessing a sophisticated mind early on, as Klein described.

ROBERT D. HINSHELWOOD

*See also:* Archetype (analytical psychology); Controversial discussions; Isaacs-Sutherland, Susan; Imago; Logic(s); Primal, the.

### **Bibliography**

- Freud, Sigmund. (1900a). The interpretation of dreams. *SE*, 4: 1–338; 5: 339–625.
- . (1908c). On the sexual theories of children. *SE*, 9: 205–226.
- . (1919). ‘A child is being beaten’: A contribution to the study of the origin of sexual perversions. *SE*, 17: 175–204.
- Isaacs, Susan. (1948). On the nature and function of phantasy. *International Journal of Psycho-Analysis*, 29, 73–97.
- Klein, Melanie. (1955). The psycho-analytic play technique: Its history and significance. In Klein, Melanie, Heimann, Paula, and Money-Kyrle, Roger E. (Eds.), *New directions in psycho-analysis*. London: Tavistock Publications.
- Mahler, Margaret S., Pine, Fred, and Bergman, Anni. (1975). *The psychological birth of the human infant*. New York: Basic Books.
- Piaget, Jean. (1954). *The construction of reality in the child* (Margaret Cook, Trans.). New York: Basic Books. (Original work published 1937)
- Segal, Hanna. (1991). *Dreams, Phantasy, and Art*. London: Institute of Psycho-Analysis/Routledge.
- Stern, Daniel N. (1985). *The interpersonal world of the infant: A view from psychoanalysis and developmental psychology*. New York: Basic Books.

---

## **UNCONSCIOUS, THE**

“The division of the psychical into what is conscious and what is unconscious is the fundamental premise of

psychoanalysis” (1923b, p. 19). The unconscious emerged from practical treatments, from the theory of repression, and from the theory of sexuality. The adjective qualifies localized formations in a state of repression, various processes, and later on, agencies as well. The noun describes the “locality” that, according to the first topography, is set against the preconscious-conscious system. Both the adjective and the noun imply that psychical life is in conflict (the dynamic point of view); that memory exists without interest, that the energetics, indeed, the structure of psychic processes is determined, on the whole, beyond consciousness (the economic point of view); and that finally inaccessibility to consciousness is undeniable (the descriptive point of view). Freud transformed philosophical and psychiatric tradition with these ideas and his refinement of the terms (Hartmann, 1931; Whithe, 1961).

When he advanced the theory of repression and the psychoneurosis of defense in 1894, Freud managed without the word *unconscious*. Thus ideas (or representations) that were intolerable, irreconcilable, repressed, durable, and pathogenic were beyond association, forgotten, outside of consciousness. Freud then made use of the term *unconscious* three times in *Studies on Hysteria* and called for research: “The ideas which are derived from the greatest depth and which form the nucleus of the pathogenic organization are also those which are acknowledged as memories by the patient with greatest difficulty. Even when [...] the patients themselves accept the fact that they thought this or that, they often add: ‘But I can’t remember having thought it.’ It is easy to come to terms with them by telling them that the thoughts were *unconscious*. But how is this state of affairs to be fitted into our own psychological views? [...] It is clearly impossible to say anything about this [...] until we have arrived at a thorough clarification of our basic psychological views” (1895d, p. 300). The advances made during 1895—childhood trauma, afterwardsness (deferred action), the dream as wish-fulfilment, and finally the “Project for a Scientific Psychology” (1950c [1895]), where the “system of impermeable neurones [w]” figures as a precursor to the unconscious—allow Freud to describe as unconscious pre-sexual sexual childhood traumas and the psychical work that they lead to, which he further constructed through practice and via theory from 1896 onwards (1896b). The discovery of unconscious fantasies and their efficacy (letters to Wilhelm Fleiss from September 21 and October 3

and 15, 1897) contributed to the creation of the unconscious in 1899 in *The Interpretation of Dreams* (1900a). The close and fundamental correlation between the unconscious, the infantile, and the sexual was affirmed.

Freud defined psychoanalysis as the science of the unconscious-soul (*unbewusst-seelisch*) and the psychology of the unconscious (*Ucs.*), which evolved according to the advances of psychoanalysis. Via the local aetiology of neurotic symptoms, he discovered that the dream was similarly constructed and that the *Ucs.* becomes the generic psychic system. It contains wishes—unconscious and indestructible—and the repressed, cathected by the libido through free energy and regulated by the pleasure principle. The primary processes (displacement, condensation) preside over the *Ucs.* The conflict between repressed instinctual motion and censoring force creates the dream, the paradigmatic compromise-formation. “If we look at unconscious wishes reduced to their most fundamental and truest shape, we shall have to conclude, no doubt, that *psychical* reality is a particular form of existence not to be confused with *material* reality” (1900a, p. 620). The reality of the *Ucs.* reveals itself in other localized processes such as joking, in the forgetting of words, and other symptomatic activities.

Freud’s investigations into the “second step in the theory of the instincts” are continued in “The Unconscious” (1915e). The dependence of the *Ucs.* on the instincts and repression is stressed. It is primal repression that creates the *Ucs.* that above all “contains the thing-cathexes of the objects, the first and true object-cathexes” (p. 201) while “the nucleus of the *Ucs.* consists of instinctual representatives which seek to discharge their cathexis; that is to say, it consists of wishful impulses” (1915e, p. 186). Freud notes, in 1917, that the *Ucs.* is the *missing link* (“*chaînon manquant*”) between soma and psyche (in 1960a).

The life and death instincts, as well as the agencies id, ego, and superego, the “third step in the theory of the instincts” (1920g), do not destroy a single previous experience. The id incorporates the *Ucs.* and inherits its characteristics, while the assets of the adjective “unconscious” accrue from the id and to a large extent from the ego, hence its resistance to the sense of guilt, to most of the processes of the superego, and to the conflicts between agencies.

There is no psychoanalytic notion that does not have some connection to the unconsciousness that the

dynamic point of view imposes universally. The more or less localized ideas moving beyond the first topography exist in relation to the *Ucs.* and are included in the id. The “Mystic Writing Pad” delighted Freud (1925a) because it represented the system *Ucs./Pcs.-Cs.* The repository for memory traces, as well as a place of fixation, the *Ucs.* is even assumed to retain an instinctual foundation analogous to animal knowledge, as in inherited psychic formations and the traces of human history.

Having often clarified his views, Freud was always careful to separate the essentially dynamic unconscious from the latent, which was susceptible to becoming conscious. By arguing for posthypnotic suggestion, the dream, and other experiences associated with the first topography, he refuted the philosophers’ view of the unconscious as paradoxical, and taking up this question of the ambiguity of the “Unconscious,” he noted: “no one has a right to complain because the actual phenomenon expresses the dynamic factor ambiguously” (1923b, p. 16) (an intuition verified through the qualitative dynamic). In 1938 he criticized a presentation of the ego and the id as follows: “What is unsatisfactory in this picture—and I am aware of it as clearly as anyone—is due to our complete ignorance of the *dynamic* nature of the mental processes. We tell ourselves that what distinguishes a conscious idea from a preconscious one, and the latter from an unconscious one, can only be a modification, or perhaps a different distribution, of psychical energy. We talk of cathexes and hypercathexes, but beyond this we are without any knowledge on the subject or even any starting-point for a serviceable working hypothesis” (1939a). The qualitative dynamic, which endorses Freudian stylization, permits some working hypotheses.

ALAIN DE MIJOLLA

*See also:* Psychic apparatus; Splitting; “Claims of Psychoanalysis to Scientific Interest”; Collective unconscious (analytical psychology); Colloque sur l’inconscient; Consciousness; Formations of the unconscious; Graph of Desire; Idea/representation; Instance; Interpretation; *Introductory Lectures on Psycho-Analysis*; *Jokes and Their Relation to the Unconscious*; Kantianism and psychoanalysis; Knot; Letter, the; Linguistics and psychoanalysis; Matheme; Metaphor; Metapsychology; Metonymy; Myth of origins; Object *a*; Parade of the signifier; Subject’s desire; Philosophy and psychoanalysis; Preconscious, the; “Recommendations to Physicians Practicing Psychoanalysis”; Science and psychoanalysis; Seminar, Lacan’s; Signifier; Signifier/signified; Splitting of the subject; Subconscious; Subject; Subject of the unconscious;

Symptom/sinthome; Topographical point of view; Topology; Word-presentation.

### **Bibliography**

- Freud, Sigmund. (1896b). Further remarks on the neuro-psychoses of defence. *SE*, 3: 157–185.
- . (1900a). The interpretation of dreams. Parts I and II. *SE*, 4–5.
- . (1915e). The unconscious. *SE*, 14: 159–204.
- . (1920g). Beyond the pleasure principle. *SE*, 18: 1–64.
- . (1923b). The ego and the id. *SE*, 19: 1–66.
- . (1925a [1924]). A note upon the “mystic writing pad.” *SE*, 19: 225–232.
- . (1939a [1934–38]). Moses and monotheism: Three essays. *SE*, 23: 1–137.
- . (1950a [1887–1902]). Extracts from the Fliess papers. *SE*, 1: 173–280.
- . (1950c [1895]). Project for a scientific psychology. *SE*, 1: 281–387.
- . (1960a [1873–1939]). *Letters of Sigmund Freud, 1873–1939* (Ernst L. Freud, Ed.; Tania and James Stern, Trans.). London: Hogarth.
- Freud, Sigmund, and Breuer, Josef. (1895d). Studies on hysteria. *SE*, 2: 48–106.
- Hartmann, Eduard von. (1931). *Philosophy of the unconscious. Speculative results according to the inductive method of physical science* (W. C. Coupland, Trans.). London: Routledge. (Original work published 1869)
- Whithe, Lancelot. (1961). *L’Inconscient avant Freud*. Paris: Payot.

### **Further Reading**

- Opatow, Barry. (1997). The real unconscious: Psychoanalysis as a theory of consciousness. *Journal of the American Psychoanalytic Association*, 45, 865–890.

---

## **“UNCONSCIOUS, THE”**

“The Unconscious,” a highly structured essay of 1915, is the most important of Freud’s papers of that period on metapsychology. Freud made the unconscious the keystone of psychoanalysis. Written over a period of three weeks in 1915, “The Unconscious” is the culmination of his topographical theory (or “first topogra-

phy”). Freud musters several arguments and points discussed or established earlier, especially in *The Interpretation of Dreams* (1900a).

The work is divided into seven parts, the last being the most original. After reminding the reader that the unconscious encompasses more than just repressed material, which is only one element of it, Freud goes on to justify the hypothesis of the unconscious—that is, to show that it is necessary and legitimate since there are multiple proofs of its existence. To do this he attempts to show that the assimilation of psychic and conscious is unacceptable: “It disrupts psychical continuities, plunges us into the insoluble difficulties of psycho-physical parallelism” (1915e, p. 168); most importantly, it closes off any possibility of effective psychological research. Freud then indicates that the unconscious is not a second, foreign consciousness within us, but that there are “mental processes [that] are in themselves unconscious” (p. 171), an important distinction that emphasized acts rather than reflexes. In this connection Freud did not hesitate to invoke the Kantian view that perceptions are “identical with what is perceived though unknowable” (p. 171).

In part 2, taking it that the hypothesis of the unconscious has been accepted, Freud discusses different meanings of the term *unconscious*, reprising previously discussed material concerning the distinction between the unconscious and the preconscious. He notes in passing that these distinctions do not, “for the present,” imply any claims concerning anatomical areas of the brain; they refer only to “regions in the mental apparatus, wherever they may be situated in the body” (p. 175); the term *regions* should thus be taken in the sense of a fiction (p. 175).

Part 3 refers in part to the second of Freud’s metapsychological papers, “Repression” (1915d), which discusses the instincts. Freud draws an important distinction here: “ideas are cathexes—basically of memory-traces—while affects and emotions correspond to processes of discharge, the final manifestations of which are perceived as feelings” (p. 178). “Affectivity,” he adds in a note, “manifests itself essentially in motor (secretory and vasomotor) discharge resulting in an (internal) alteration of the subject’s own body without reference to the external world” (p. 179n). This clearly raises the issue of the actual neuroses, though Freud does not address it here.

Part 4 deals with the topography and dynamics of repression, and it is here that Freud provides his well-known definition of metapsychology: “It will not be

unreasonable to give a special name to this whole way of regarding our subject-matter, for it is the consummation of psycho-analytic research. I propose that when we have succeeded in describing a psychical process in its dynamic, topographical and economic aspects, we should speak of it as a metapsychological presentation” (p. 181). As in “Repression” (1915d), Freud specifies repression relative to anxiety hysteria, to phobia in conversion hysteria, and to obsessional neurosis.

Part 5, which covers the specific properties of the unconscious system, includes some very important thoughts on time: “The processes of the system *Ucs* are *timeless*—i.e., they are not ordered temporally, are not altered by the passage of time; they have no reference to time at all. Reference to time is bound up, once again, with the work of the system *Cs*” (p. 187). But this is only one aspect of the characteristics of the unconscious system, which Freud lists as follows: “*exemption from mutual contradiction, primary process (mobility of cathexes), timelessness, and replacement of external by psychical reality*” (p. 187).

After discussing the preconscious, Freud goes on in part 6 to examine the relations between the two systems, which are distinct but whose respective impulses may cooperate if they happen to be tending in the same direction. “The content of the *Ucs*,” Freud concludes, “may be compared with an aboriginal population in the mind. If inherited mental formations exist in the human being—something analogous to instinct in animals—these constitute the nucleus of the *Ucs*. Later there is added to them what is discarded during childhood development as unserviceable; and this need not differ in its nature from what is inherited. A sharp and final division between the content of the two systems does not, as a rule, take place till puberty” (p. 195).

The seventh and last part of Freud’s paper is the most audacious; Freud asserts that only the analysis of narcissistic psychoneuroses (what we would now call psychoses), can “furnish us with conceptions through which the enigmatic *Ucs* will be brought more within our reach and, as it were, made tangible” (p. 196). He cites Karl Abraham on dementia praecox and Victor Tausk on schizophrenia, and he develops a number of important themes about the speech of schizophrenics. Using Tausk’s clinical observations, Freud notes that “the schizophrenic utterance exhibits a hypochondriac trait: it has become ‘*organ-speech*’” (p. 198). Discussing Eugen Bleuler and Carl Jung, he writes that “in schizophrenia words are subjected to the same process as

that which makes the dream-images out of latent dream-thoughts—to what we have called the primary psychical process” (p. 199). The relationship to words thus takes precedence over thing-presentations, and substitutions are made based on verbal identity rather than on similarity between the things designated, which is what makes schizophrenic speech so disconcerting. In this way Freud introduces a more general analysis of the thought process, evoking cathexes far removed from perception which “attain their capacity to become conscious only through being linked with the residues of perceptions of *words*” (p. 202).

Freud concludes this most brilliant and profound of his papers on metapsychology as follows: “When we think in abstractions there is a danger that we may neglect the relations of words to unconscious thing-presentations” (p. 204).

SOPHIE DE MIJOLLA-MELLOR

See also: Metapsychology; Thing-presentation; Unconscious, the; Word-presentation.

### Source Citation

Freud, Sigmund. (1915e). Das Unbewusste. *Internationale Zeitschrift für ärztliche Psychoanalyse*, 3, 189–203, 257–269; *GW*, 10: 264–303; *SE*, 14: 166–204.

### Bibliography

Freud, Sigmund. (1900a). The interpretation of dreams. *SE*, 4–5.

———. (1915d). Repression. *SE*, 14: 141–158.

---

## UNDOING

The mechanism of undoing is characteristic of obsessional neurosis, along with isolation. It involves a process of “negative magic” that, according to Freud, tends to undo what has been done. When an action is undone by a second action, it is as if neither had occurred, whereas in reality both have taken place.

In a letter to Fliess written on December 22, 1897, Freud already foresees what he defines at that time as the ambiguity or imprecise meaning characteristic of obsessional neurosis. He would later describe this as an action that occurs in a second moment, and which seeks to



undo an action that precedes it. “Obsessional ideas are often clothed in a remarkable *verbal vagueness* in order to permit of this multiple employment” (1950a, p. 273).

In the “Rat Man” (1909d), Freud describes compulsive acts as unfolding in two moments, during which the first is undone by the second. According to him in obsessional thought “the patient’s consciousness naturally misunderstands them [the compulsive acts] and puts forward a set of secondary motives to account for them—*rationalizes them*, in short” (p. 192). In reality there is an opposition between love and hate. In *Inhibitions, Symptoms and Anxiety* (1926d), he defines more specifically the “magical” nature of this defense that “no longer [has] any resemblance to the process of ‘repression’” (p. 164). Thus the obsessive ceremony strives not only to prevent the appearance of an event but to undo it, which is irrational and magical and most likely arises from an animist attitude toward the environment. Anna Freud (1936) included undoing in her repertory of ego defenses.

The concept of undoing has today acquired a certain psychological connotation. It is often confused with the concept of ambivalent behavior or attitude. It is probably also necessary to distinguish it, because of the “magical” character of the defense, from the series of mechanisms discovered by Freud—repression, foreclosure, negation (or denegation), disavowal (or denial)—a series that is commonly referred to today as the work of negativization.

ELSA SCHMID-KITSIKIS

*See also:* Anxiety; Defense mechanisms; *Inhibitions, Symptoms, and Anxiety*; Obsessional neurosis; Rite and ritual; *Ego and the Mechanisms of Defense, The*.

### **Bibliography**

Freud, Anna. (1909d). Notes upon a case of obsessional neurosis. *SE*, 10: 155–249.

———. (1936). *The Ego and the Mechanisms of Defence*. London: Hogarth Press; New York: International Universities Press, 1966.

———. (1950a [1887–1902]). Extracts from the Fliess papers. *SE*, 1: 173–280.

---

## **UNITED STATES**

Psychoanalysis came to North America in two major waves, the first one following Freud’s visit in 1909,

and the second one following the Nazi takeover in Germany and Austria. Each wave stimulated the exploration of psychoanalysis’ scientific and curative potentials while encouraging popularizations by the American public. However, this dual, though separate, reception engendered ambiguities and misunderstandings, and built up unwarranted expectations that led to inevitable disappointments.

American physicians had been seeking to cure neurasthenia, which, already in 1869, George M. Beard (1840–1883) had called “the American disease” arising from so-called “civilized morality”—hidden conflicts due to hypocrisy. According to Beard, upwardly mobile citizens professing continence, religious purity, and even married celibacy, were having illicit affairs with “loose” women, which often created “mental problems.”

Around the turn of the century, American neurologists such as Morton Prince (1854–1929), James Jackson Putnam (1842–1918) and S. E. Jelliffe (1866–1945) had been investigating the “French school” of Charcot, Bernheim, and Janet, and were practicing suggestion and (occasionally) hypnosis in order to cure these neuroses. So were psychologists, among them Stanley Hall (1844–1924), William James (1842–1910), and Boris Sidis (1867–1933). When they read that Freud’s patients by talking about previously repressed fantasies had lost their hysterical symptoms, and that this had happened by bringing forth unconscious memories, they wanted to learn about his method, and about the relation between his patients’ symptoms and sexual repression.

Consequently, philosophers, psychologists, and the educated public were as interested in what Freud had to say as were American psychiatrists—who were caring for psychotic patients in institutions and did not know how to cure neuroses—and clergymen who were no longer able to help people by instilling a fear of God.

For these reasons, Freud’s visit to Clark University attracted diverse listeners: the psychologists William James and Edward Bradford Titchener, the anthropologist Franz Boas, the revolutionary anarchist Emma Goldman, and many Protestant clergymen, psychiatrists, and neurologists—among them Abraham Arden Brill (1874–1948), Adolph Meyer (1866–1950), and James Jackson Putnam. Freud’s lectures, which for the first time synthesized his discoveries, turned out to be tailor-made for this audience. He spoke extemporaneously. He stressed his hopes for the scientific exploration of the laws governing the unconscious; the

liberating benefits psychoanalysis would bring to individuals and humanity; the role of sublimation, of trauma and catharsis; and the efficacy and benefits of psychoanalytic intervention. The American press gave him wide, even sensationalist, coverage, so that he was met with an enthusiasm usually accorded entertainers and charismatic heads of state. Then, general physicians and neurologists wanted to understand more about the influence of the unconscious on illness; feminists and other radicals foresaw the end of sexual and social repression; and mind healers perceived answers to troubling questions. To them all, psychoanalysis promised to resolve theoretical dilemmas, while offering a method to help ailing, malingering patients: it became a pivot for disparate intellectual endeavors and disciplines, aims, and interests.

Since the analysis of dreams caught the imagination of the larger American public, psychoanalysis started being cast as the new road to happiness. Broad applications ensued, not only by doctors and clergymen but by social workers, experts in child rearing, and in criminology. And zealous charlatans called themselves psychoanalysts.

Freud was dismayed by these facile applications that bypassed the laborious efforts required to reach the deepest unconscious of patients. As he stated in “On the Question of Lay Analysis” (1926a), “Americans came too easily by truths others had struggled to discover . . . and were too easily satisfied with superficial appearances.”

However, Freud kept in touch with a number of Americans. On November 9, 1909, for instance, Putnam wrote: “Your visit to America was of deep significance to me, and I now work and read with constantly growing interest on your lines.” Less than a month later, he informed Freud that “the real psychoanalysis begins where the primary ‘confessional’ ends.” Freud urged his American correspondents to organize and to affiliate with the International Psychoanalytical Association (IPA)—which had been launched to facilitate communication among followers wanting to exchange scientific information.

By 1911, twelve persons, mostly physicians, set up the American Psychoanalytic Association (APA). In the same year, fifteen physicians, under the leadership of A. A. Brill, established the New York Psychoanalytic Society (NYPS). By 1914, they founded the Boston Psychoanalytic Society, appointing Putnam as president, and soon formed groups in the Washington-Baltimore area and

in Chicago. But despite these organizational setups, the first wave of American Freudians was too geographically and/or intellectually dispersed to make many scientific contributions, and thus crested after a few years.

By then, psychoanalysis was expected to explain nearly every individual and social phenomenon in the culture at large: the American propensity to overgeneralize was casting psychoanalysis as a cure-all. As Nathan Hale summarized, “between 1915 and 1918 psychoanalysis received three-fifths as much attention as birth control, more attention than divorce, and nearly four times more than mental hygiene. . . . The unconscious had become a Darwinian Titan and dream analysis the road to its taming” (Hale, 1971, p. 397). Proselytizing practitioners bragged to journalists of miracle cures, and reporters wedded clichés to exaggerations and heightened enthusiasm.

During these years, Freud wrote to Putnam about the impending splits with Alfred Adler and Carl Jung. But he did not yet realize that the American ambiance would engender other sorts of splits. Since the American groups, mostly, were started by self-selected and self-trained doctors, they differentiated themselves—professionally—from the growing numbers of social workers, clergymen and charlatans who were also doing “psychoanalysis.” This disjuncture between psychoanalysis’ public acclaim and its (flagging) clinical success was unique to North America and, ultimately, created a storm within the movement. By 1924, due to a mixture of professional responsibility and self-interest, and to desperation, the APA voted to keep out *all* lay analysts. At the IPA meetings in Innsbruck, in 1927, twenty-eight papers were presented on the question of lay analysis. Wanting to distance themselves from “impostors,” American Freudians remained adamant and insisted on breaking IPA rules against lay analysts by restricting access to physicians alone. They even referred to Freud as the “Pope in Vienna.” Freud expressed his disagreement with the Americans in “On the Question on Lay Analysis” (1926a).

Nevertheless, American psychoanalysts realized that they were not keeping up with scientific advances and that they needed more training. Therefore they invited a number of Europeans as training analysts (including Freud, who refused for reasons of health). By 1930, they formed the Chicago Institute under the aegis of Franz Alexander (1891–1964), and in 1931, the New York Psychoanalytic Institute under the aegis of Sándor Radó (1890–1972). But the rift between European

and American Freudians continued to widen over training lay analysts. In 1936, the APA declared that it would veto any resolution by the IPA addressing American issues, and by 1938 had set up its own criteria for “minimal training of physicians” at its affiliated institutes, spelled out proper conduct of members, and reaffirmed the ban against laymen. They also put the IPA on notice not to train Americans who had not already been “approved” by the APA.

In a way, Freud had described some of these dilemmas as arising from the fact that psychoanalysis was a social and intellectual movement, a clinical therapy, and a theory of mind. He maintained that these major thrusts were bound to come into conflict from time to time. But he could not foresee that the Nazis would come to power, that most of his disciples would move to America, and that World War II would nearly abolish psychoanalysis on the European continent.

America’s second major wave of psychoanalysis arrived with the émigrés. From the start, Freud had referred to his disciples as pioneers into the workings of the unconscious. After the majority of these disciples arrived in the country of pioneers they, literally, were cast as pioneers for their cause.

At first, their reception was mixed. American psychoanalysts had sent affidavits, and Lawrence Kubie (1896–1973) had organized an extremely efficient Emergency Committee to help them get into the country. But members of the American Medical Association were afraid that the Europeans would compete for their jobs and patients. Legally, immigrants had to become American citizens before practicing medicine in all but five states; and they had to pass medical boards before becoming psychoanalysts. They also had to prove that they would be self-supporting within a year before they entered the country, and they were branded as Jews. They already had to adapt to their delegitimation as psychoanalysts and human beings, to overcome the shock of brutal ostracism. Now, they had to learn English in order to establish themselves in their (still) struggling profession. Many émigré Freudians worked in hospitals. There, they could demonstrate the efficacy of the “talking cure” to colleagues. By 1942, every medical student learned about the unconscious factors that might influence their patients’ behavior. Many of these students later became psychoanalysts.

Under the circumstances, the organizational feuds receded. The émigrés became a resource for American

colleagues. They offered training analyses and held the most prestigious positions in the new institutes that, mostly under their leadership, were springing up around the country. The former disagreements were not settled, but Freud’s death in September 1939 and the war overshadowed IPA concerns. What would have happened to psychoanalysis had most of its proponents not come to America after the Nazis took power (a much smaller contingent went to South America and England) is a moot question.

In North America, the organizational repercussions of the split between medical and lay analysts at first determined who among the émigrés would be allowed into the APA and its affiliates, but later on this differentiation led to the formation of “deviant” associations. Still, some prominent psychologists who had been close to Freud, such as Ernst Kris (1906–1957), Siegfried Bernfeld (1892–1953), Erik Erikson (1902–1994), Otto Fenichel (1897–1946), and Theodore Reik (1888–1970), were accepted as “honorary members.” But Reik, for instance, did not appreciate this distinction and, by 1948, started his own society—to train psychologists in psychoanalysis. His graduates, in turn, taught others. Similar situations arose in cities throughout the country, especially on the two coasts. Already in 1941, Karen Horney (1895–1952) had left the New York Psychoanalytic Institute (NYPI) after a heated controversy over theoretical priorities which would determine, also, what type of psychoanalysis candidates were going to learn and then to practice. Basically, she argued that her colleagues’ ego-oriented psychoanalysis was culture-bound rather than universal, and that they ought to address a patient’s present circumstances in order to understand his or her past rather than to begin by eliciting insights into this past.

By then, Karen Horney’s books, (1937, 1939), as well as Erich Fromm’s (1942) were introducing psychoanalytic concepts to a broad public—which was not all that interested in the theoretical disputes among psychoanalysts, but found their writings more accessible than the works of the “classical Freudians.” In fact, Horney and Fromm were addressing social issues, and, though far from simplistic, were appealing to the American habit of believing in quick fixes, and to the native optimism about the malleability of human nature. But they were only the forerunners of what would become some of the “cultural” or “applied” psychoanalyses and psychotherapies which subsequently flooded the country. In other words,

Freud's influence on the culture—whether appreciated or rejected—from then on became ubiquitous.

Still, the theories based on Freud's postulates in *The Ego and the Id* (1923b) would dominate the profession for a long time. The division into id, ego, and superego as structural components of psychic life converged with the American scientific bent, and with the language of medicine.

But other proliferations of psychoanalysis occurred via the social sciences. For instance, anthropologists such as Margaret Mead, Gregory Bateson, and Ruth Benedict, and psychoanalysts such as Sándor Radó and Abram Kardiner, in the Columbia University Institute for Psychoanalytic Training, were doing research on tribal societies; the Harvard sociologist Talcott Parsons postulated psychoanalysis as a mainstay of his social system, to incorporate the unconscious elements of human motivation into social institutions; and the political scientist Harold Laswell explored the behavior and ambitions of political figures in terms of their psychic make-up.

Like Freud, the émigrés were steeped in the classics. They were products of the Enlightenment, and they foresaw that the future of civilization would be dominated by discoveries science alone could further. But they also kept reading classical and contemporary literature in order to enrich their theories. And they explained human psychology—the typical patterns of mind being formed in response to early experiences that later guide behavior—via literature. They continued to attempt analyzing literary works in relation to the personalities of their authors, and to be particularly interested in having creative individuals on their couches. Therefore, they cooperated with literary scholars such as Lionel Trilling, and art critics such as Ernst Hans Gombrich and Clement Greenberg who, themselves, enriched the studies of literature, art, and criticism by responding to the challenges posed by psychoanalysis. They warmly welcomed psychoanalysts, and arranged meetings and symposia with them, thereby furthering the acceptance of psychoanalytic insights by the intelligentsia.

Because Freud's European disciples had come to psychoanalysis not only from medicine but from art (Erik Erikson and Ernst Kris), education (Anna Freud [1895–1982]), philosophy (Robert Waelder [1900–1967]), and literature (Henry Lowenfeld [1900–1985]), they were attuned to the preoccupations of

American intellectuals. And the self-assurance they had gained from their work with Freud, as well as their range, helped propel them into the maelstrom of American intellectual life.

Heinz Hartmann, for instance, a central figure among the so-called “scientific ego psychologists,” already in Vienna, had addressed questions of adaptation. Now, he investigated individuals' relations with and adaptation to reality as indicators of mental health which, he held, was emotional *and* biological. He maintained that “instinct” has a double meaning: the genetic relations between animal instinct and human drive, and between animal instinct and human ego-function. This brought him back to addressing cultural issues. Together with Ernst Kris and Rudolph Loewenstein (1946), he wrote the definitive paper summarizing the clinical theories Freudians had derived from their (recent) America-based research. These findings were syntheses on a highly abstract, theoretical plane. The general and cultural questions they were addressing, along with the clinical ones, would set the Freudians' extensive research agendas for the coming years. This acceptance in America, at least in part, is what made their work so appealing after the war, when they reconvened on the European continent, and why their theories were referred to as “American” psychoanalysis.

In 1947, David M. Levy, in *New Fields of Psychoanalysis*, delineated the astounding influence psychoanalysis had gained in every sphere. He noted that psychoanalytic terminology in child guidance, such as maternal overprotection, maternal rejection, etc., had become ubiquitous; that psychoanalysis could predict criminals' recidivism; and he outlined collaborations among psychoanalysts, social workers, educators, industrial and military psychiatrists. Clearly, Freud's disciples had become pillars of the American establishment. Inevitably, prestige and research moneys accrued to the profession.

Ego-psychology remained the leading theory well into the 1970s. By then, however, the members of groups outside the APA were increasingly discontent: they resented being peripheral. Their own successes with patients, and their work in hospitals, went nearly unrecognized outside the country. At home, they were analyzing psychologists and social workers who, sooner or later, formed associations and networks—which gave them a certain amount of clout. Belonging to the IPA would allow them, too, to mix and exchange information with European and Latin American colleagues, and to set up collaborative research projects. In 1985, this situation came to a head in a lawsuit by non-medical

American Freudians—some of whose institutes have since then been accepted by the IPA and the APA.

Altogether, by the time Philip Reiff published *The Triumph of the Therapeutic* (1966), America had become the therapeutic society par excellence. But the patients who expected psychoanalysts to cure their neurotic symptoms, or their general malaise, were very different from Freud's repressed, hysterical ones. And the analyses by his many descendants were initiating more and more discussions about changing clinical pictures and problems, and possible solutions to them. Gradually, the clinical techniques based on the "structural theory" (the division of the personality into id, ego, and superego) were being questioned, and no longer seemed to be as efficacious as they had been before. And many people argued that psychoanalysis took too long and was too expensive.

By 1971, Heinz Kohut (1913–1981), a member of both the APA and the IPA, had been dissatisfied enough to have explored, and then moved, Freud's theories of narcissism to the center. He had noted that children tend to make up for the "unavoidable shortcomings" of maternal care, and the concomitant primary narcissism, either by evolving a *grandiose* and exhibitionist *self-image*, or by creating an *idealized parental image*. As the gleam in the mother's eye mirrors the child's exhibitionist display, he found, the child's self-esteem and grandiosity became inflated. This necessitated, he said, more empathic and demanding interactions with patients, rather than the classical analyst's technique of abstinence. His so-called self-psychology, which focuses on the interactions between mother and child, became more integrated into the classical Freudians' practices. Soon thereafter object-relations theory (based primarily on the relationship between mother and infant), which originally had been advanced by Melanie Klein (1882–1960), in London, was being furthered by Otto Kernberg.

Whether or not these approaches were due to changing symptomatology alone, or to the fact that the acceptance of psychoanalysis itself had made promises for cures it could not achieve, is a debatable issue. Certainly, contact with psychoanalysts from Europe and South America, and changing cultural trends, were playing their part as well. (In academic circles, beginning in departments of English and French, Lacanian psychoanalysis made large inroads.) But psychoanalysts, themselves (Kurzweil, 1989, 1995) were both products and shapers of their culture. In sum, in the

United States psychoanalysis has evolved in line with cultural prerogatives and advances in psychoanalytic knowledge. What aspects of psychoanalysis are being stressed or denied keeps changing, and its first and second major waves undoubtedly will be followed by others. On the one hand, Freudian ideas are permeating American society, which, in turn, influences the practice of psychoanalysis itself. On the other hand, there has been a proliferation of therapies. But the popularization has encouraged simplifications and quick modes of treatment at the expense of analyzing the unconscious. Thereby, what Freud called the "gold of psychoanalysis," that is, the mining of the unconscious, has been lost. However, many of his contributions live on in the culture at large, and are applied by many social scientists, especially psychologists.

EDITH KURZWEIL

### Bibliography

- Hale, Nathan G., Jr. (1971). *Freud and the Americans: The beginnings of psychoanalysis in the United States, 1976–1917*. New York: Oxford University Press.
- Horney, Karen. (1939). *New ways in psychoanalysis*. New York: W. W. Norton.
- Kurzweil, Edith. (1989). *The Freudians: A comparative perspective*. New Haven, CT: Yale University Press.
- . (1995). *Freudians and feminists*. Boulder, CO: Westview.

## UNPLEASURE

From the beginning of psychoanalysis, the term *unpleasure*, in the ordinary sense of a disagreeable impression, was chosen by Sigmund Freud for its dynamic dimension in psychic functioning. He noted the role of "feelings of unpleasure" in the speech of his patients and their defenses against the painful contents of their thoughts. In "On the Psychological Mechanism of Hysterical Phenomena: Preliminary Communication" (1893a) by Freud and Josef Breuer, these painful affects—fear, anxiety, shame, physical pain—are enumerated and their contribution to the formation of hysterical symptoms is explained: The unpleasure they elicit triggers forgetting, repression.

In Freud's position of the primitive psychic apparatus in *The Interpretation of Dreams* (1900a), an economic

perspective predominates: Unpleasure, engendered by the increase in tensions due to excitation, sets in motion the functioning of the psychic apparatus. “The psychical apparatus is intolerant of unpleasure; it has to fend it off at all costs, and if the perception of reality entails unpleasure, that perception—that is, the truth—must be sacrificed” (p. 237), he writes in “Analysis Terminable and Interminable” (1937c). Unpleasure is a broader category than anxiety, although anxiety is certainly unpleasurable. Other affective states such as tension, pain, or grief are also unpleasurable; so, too, is inhibition. Unpleasure is thus not only an affective state, it is set up as a principle that regulates psychic functioning.

MICHÈLE POLLAK CORNILLOT

*See also:* Automatism; *Basic Neurosis (the)-Oral regression and psychic masochism*; Defense; Discharge; Dualism; Ego; Excitation; Hatred; Historical reality; Hypochondria; *Inhibitions, Symptoms and Anxiety*; “Instincts and Their Vicissitudes”; Jouissance (Lacan); Metapsychology; Moral masochism; Negative transference; Nirvana; Pain; Pleasure ego/reality ego; Pleasure/unpleasure principle; Principle of constancy; Principle of mental functioning; “Project for a Scientific Psychology, A”; Protective Shield; Purified-pleasure-ego; Reality principle; “Repression”; Suffering; Symptom-formation; Thing, The.

### **Bibliography**

Freud, Sigmund. (1900a). The interpretation of dreams. Part I, *SE*, 4: 1–338; Part II, *SE*, 5: 339–625.

———. (1937c). Analysis terminable and interminable. *SE*, 23: 209–253.

Freud, Sigmund, and Breuer, Josef. (1893a). On the psychical mechanism of hysterical phenomena: Preliminary communication. *SE*, 2: 1–17.

### **Further Reading**

Villele, L. (1997). From the sway of the pleasure principle: Ghost of a tiger. *Psychoanalytic Review*, 84, 281–294.

Wise, I. (2000). Pleasure in phantasy and reality. *International Journal of Psychoanalysis*, 81, 156–158.

from caregivers. The idea was introduced by Robert Stolorow and George E. Atwood in 1989. In their theory of intersubjectivity, the child’s conscious experience is pictured as becoming progressively articulated through the validating attunement of caregivers. Features of the child’s experience may remain unconscious, not because they have been repressed, but because, in the absence of a validating intersubjective context, they were never articulated in the first place.

The concept of the unvalidated unconscious sheds light on certain psychosomatic conditions in which affects fail to evolve from bodily states to symbolically integrated feelings because, without validating symbolic (verbal) responses from caregivers, they were never symbolically articulated. These conditions can be distinguished from other conditions that develop when symbolic articulation of affect is defensively aborted. The concept of the unvalidated unconscious has features in common with Freud’s notion of a primal unconscious and Bion’s discussion of undigested experience.

Analytic attention to the unvalidated unconscious is especially important in the treatment of patients for whom broad areas of early experience failed to evoke validating attunement in caregivers and, consequently, whose perceptions remain ill defined and precariously held and whose affects tend to be felt as diffuse bodily states. In such cases, analytic investigation serves to articulate and crystallize the patient’s subjective reality.

ROBERT D. STOLOROW

*See also:* Prereflective unconscious.

### **Bibliography**

Stolorow, Robert D., and Atwood, George E. (1989). The unconscious and unconscious fantasy: An intersubjective-developmental perspective. *Psychoanalytical Inquiry*, 9, 364–374.

———. (1992). *Contexts of being: The intersubjective foundations of psychological life*. Hillsdale, NJ: Analytic Press.

## **UNVALIDATED UNCONSCIOUS**

The term *unvalidated unconscious* refers to childhood experiences that could not be consciously articulated because they never evoked sufficient validating responses

## **URBANTSCHITSCH (URBAN), RUDOLF VON (1879–1964)**

Rudolf von Urbantschitsch, an Austrian physician, was born in Vienna on April 28, 1879, and died on December 18, 1964, in Carmel, California.

He was born into a Catholic and aristocratic family that enjoyed a good reputation in the days of the Hapsburg monarchy. His father, Victor Urbantschitsch, was one of the founders of modern ENT medicine. Rudolf was a student at the Vienna Theresianum, from which he graduated in 1898. In 1914, having finished his medical studies, he became the assistant of Karl von Noordens and directed his clinic.

With the support of Noordens, of influential circles in Vienna, and protected by Archduke Franz Ferdinand, heir to the throne, he was able to realize his project of creating a clinic for the Viennese aristocracy. The Wiener Cottage Sanatorium was opened under his directorship in 1908 and became one of the most prestigious institutions in Europe. The Viennese medical profession cared for its most well-to-do patients there.

At the end of 1907, Fritz Wittels, who practiced as a physician in the Cottage Sanatorium, introduced Urbantschitsch to the group of Viennese psychoanalysts. In January 1908 he presented a paper, "Meine Entwicklungsjahre bis zur Ehe" (From my puberty to my marriage), and went on to become a member of the Wednesday psychology society. He remained a member until 1914. Sigmund Freud hospitalized some of his patients in the Cottage Sanatorium, Sergei Pankejeff (the "Wolf Man") for one.

In 1920, Urbantschitsch lost his position as sole director of the Cottage Sanatorium and the institution was sold in 1922. Following this loss and on Freud's recommendation he began to train as an analyst, first with Paul Federn and then with Sándor Ferenczi in Budapest. As a Catholic, an aristocrat, and a monarchist, Urbantschitsch was an exception in the social makeup of the Vienna Psychoanalytic Society. Through his intense lecturing activity both in Austria and abroad he contributed to vulgarizing the discoveries of psychoanalysis but ran up against the criticism of his Viennese colleagues, particularly the younger ones, for presenting psychoanalysis in a simplistic fashion and according pride of place to his personal publicity. This criticism, and also his love affairs, two of which resulted in suicide, contributed to the Vienna Psychoanalytic Society's rejecting his request to renew his membership and in 1924 he was even refused the status of a guest.

At the end of 1936 Urbantschitsch left for the United States and first settled in Los Angeles as a psy-

chotherapist. He moved to San Francisco during the summer of 1937 and to Carmel in 1941. These peregrinations were not unconnected to the fact that he had fallen foul of Ernst Simmel and the Los Angeles group of psychoanalysts, who considered his therapeutic work and his theoretical conceptions to be non-psychoanalytical in the Freudian sense of the term. In 1944 Urbantschitsch, who still insisted on considering himself as a psychoanalyst and a disciple of Freud, was accused of practicing medicine illegally.

Apart from his many vulgarizing publications, Urbantschitsch also published plays and novels under the pseudonym Georg Gorgone. His autobiography appeared in 1958 entitled *Myself Not Least: A Confessional Autobiography of a Psychoanalyst and Some Explanatory History Cases*.

ELKE MÜHLEITNER

See also: Wittels, Fritz (Siegfried).

### **Bibliography**

Mühlleitner, Elke. (1992). *Biographisches lexikon der psychoanalyse (die mitglieder der psychologischen Mittwoch-Gesellschaft und der Wiener Psychoanalytischen Vereinigung 1902–1938)*. Tübingen: Diskord.

Reichmayr, Johannes. (1991). Rudolf von Urbantschitsch (Rudolf von Urban), 1879–1964. *Revue internationale d'histoire de la psychanalyse*, 4, 647–658.

Urbantschitsch, Rudolf von. (1924). *Psychoanalyse: Ihre bedeutung und ihr einfluss auf jugenderziehung, kinderaufklärung, berufs- und liebeswahl*. Vienna-Leipzig: M. Perles.

———. (1928). *Psychoanalysis for all*. London: C. S. Daniel.

———. (1958). *Myself not least; a confessional autobiography of a psychoanalyst and some explanatory history cases*. London: Jarrolds.

---

## **URUGUAY**

The early days of psychoanalysis in Uruguay date back to the 1940s when Valentín Pérez Pastorini, a psychiatrist, began traveling to Buenos Aires to be analyzed by Pichon-Rivière. Pérez Pastorini trained with the Argentinean Psychoanalytic Association. Miguel Sesser then followed his example. Pérez Pastorini analyzed Roberto Agorio and Gilberto Koolhaas, and the group grew to include Jean Carlos Rey,

Héctor Garbarino, Juan Pereira Anavitarte and professors Laura Achard, Marta Lacava, and Mercedes Freire de Garbarino. In 1950 it was proposed to form an institute, a project that required the presence of a training analyst.

In 1954 Willy and Madeleine Baranger, French teachers who were members of the Argentinean Psychoanalytic Association, set up in the country and began to work as training analysts. Argentinean analysts traveled each week for supervisions. The group began to take shape, and from 1955 to 1956 it established bylaws and acquired legal status. It was recognized as a study group at the Twentieth Congress of the International Psychoanalytical Association in Paris in 1957 and was admitted as an affiliate association of the International Psychoanalytical Association at the twenty-second congress, held in Edinburgh in 1961.

This expansion of psychoanalysis initially met with opposition from a group of physicians who accused the psychoanalysts of illegally practicing medicine. The Sindicato médico del Uruguay (Medical Association of Uruguay) finally ruled on the question in favor of the group of analysts. Psychoanalysis then experienced a period of rapid growth. It was taught at the graduate level as part of medical and psychiatric studies, as well as in bachelor courses in psychology in the faculty of arts and human sciences. Luis E. Prego Silva introduced psychoanalytic knowledge into pediatric departments in hospitals. In 1965 the Barangers returned to Buenos Aires after a ten-year stay in Montevideo, but by this time the Uruguay Psychoanalytic Association already had three training analysts: Héctor Garbarino, Laura Achard, and Mercedes Freire de Garbarino. In 1966 the Twelfth Congress of Latin American Psychoanalysis was held in Montevideo.

The psychoanalytic movement went into a noticeably slow period during the “de facto government” from 1973 to 1985, the period of military dictatorship that forced eminent analysts to emigrate, imposed rigorous controls on meetings of the Uruguay Psychoanalytic Association, restricted the appointment of its directors, and monitored publications. All the ground that had been gained at the level of universities, hospitals, and public health was lost. In 1985, with the advent of democracy, the Uruguay Psychoanalytic Association nevertheless rapidly made up for lost time.

Among the founding members of psychoanalysis in Uruguay the following stand out for their contributions to the field in terms of theory and practice: Rodolfo Agorio, Gilberto Koolhaas, Héctor Gabarino, Mercedes Freire de Gabarino, Laura Achard, Juan Carlos Rey, and Willy and Madeleine Baranger. Also worthy of note for their contributions are Luis E. Prego Silva, Vida Maberino de Prego, Marta Nieto, Carlos Mendilaharsu, Sélika Acevedo de Mendilaharsu, Gloria Mieres de Pizzolanti, Isabel Plosa, Alberto Pereda, Myrta Casas de Peredo, Ricardo Bernardi, Marcelo Viñar, Maren Ulriksen de Viñar, Fanny Schkolnik, and Marcos Lijtenstein.

The Uruguay Psychoanalytic Association is the only organization in the country that is a member of the International Psychoanalytical Association. It is also affiliated with the Latin American Psychoanalytic Federation. There have been no splits in the organization. The Executive Committee is elected every two years at a general assembly. The Training Commission is in charge of the study program. The Scientific Commission coordinates activities within and outside the association and organizes meetings, roundtables, and domestic and international conferences. The title “training analyst” has been replaced by “analyst in didactic function,” a title that includes training, supervision, and teaching. Admission is by interview, since one of the criteria governing training is that personal analysis cannot be formally associated with the association in any way. To apply, candidates must have completed three and a half years of personal analysis. Supervised practice consists of three analyses of two years each, two of adults and one of a child. Various laboratories operate under the aegis of the Uruguay Psychoanalytic Association: laboratories that study children, adolescents, psychosis, couples and families, as well as laboratories that take research and group psychoanalytic approaches. The Centro de intercambio (Exchange Center) is responsible for spreading psychoanalysis to neighboring domains of knowledge and culture. It also provides psychoanalytic treatment for low-income patients. The Publications Commission, in addition to publishing books, has published the *Revista uruguaya de psicoanálisis* since 1956 and the journal *Temas* since 1983.

In July 2003 the president of the republic and the minister of education and culture approved the reform of the bylaws of the Uruguay Psychoanalytic Association and the foundation of the University Postgraduate



Institute of Psychoanalysis under the auspices of the association. From then on, training by the association led to a university-level master's degree in psychoanalysis. In the same year a commission was set up whose goal it was to have the Uruguay Psychoanalytic Association recognized by the Graduate School of the Faculty of Medicine of the University of the Republic as an institution entitled to organize adult training programs.

SÉLIKA ACEVEDO DE MENDILAHARSU

### **Bibliography**

- Freire de Garbarino, Mercedes. (1988). Breve historia de la Asociación psicoanalítica del Uruguay. *Revista uruguaya de psicoanálisis*, 68, 3–10.
- Freire de Garbarino, Mercedes, et al. (1995). Uruguay. In Peter Kutter (Ed.), *Psychoanalysis international: A guide to psychoanalysis throughout the world*, vol. 2 (pp. 174–185). Stuttgart, Germany: Frommann-Holzboog.
- Prego Silva, Luis E. (1996). Notas y comentarios sobre los orígenes del psicoanálisis de niños en el Uruguay. In *Psicoanálisis de niños y adolescentes en América latina* (Vol. 2, pp. 51–56). Lima, Peru: Fe.P.A.L.



## “VAGINA DENTATA,” FANTASY OF

The fantasy of “vagina dentata” (teeth in the vagina) is a horrifying image of the female genitals that derives from the sexual theories of children. It displaces from the oral cavity to the vagina a threat that children believe to come from women. The equation of mouth and vagina was introduced by Freud (1899a, 1905d) and was advanced by Karl Abraham (1916) as central to the oral-sadistic or cannibalistic stage of the infantile libido (devouring versus being devoured).

Fear of women and the great terror that they inspire, which for men is linked to castration anxiety, encompasses several other fears: a fearful representation of the all-powerful mother, in which men project outside of themselves an oral-aggressive component; fear of punishment for a desire for fusion with the archaic mother, for an incestuous bond with the mother, or for a return to the mother’s womb at the moment of coitus (Sándor Ferenczi); fear of a parent’s sadistic redirection of the sexual aim of the primal scene; a fearful infantile fantasy of incorporation in coitus (Melanie Klein); a fear of a woman’s desire for revenge for her own castration (René de Monchy). This dread of a woman’s mysterious cavity transforms it into a persecutory object that no longer inspires envy (Hanna Segal). In its passive form, the fantasy of being bitten or eaten by the genitals of a woman includes an element of bisexual desire. More often implied than stated, this fantasy turns up in various forms in dreams, stories, legends, and films.

The fantasy of teeth in the vagina must be carefully distinguished from a woman’s vaginismus (an involuntary spasm of the muscles surrounding the vagina that closes the vagina), from the fantasy of a penis with

teeth, from fear of incorporation linked to mourning, and from any nonoccidental anthropological data.

*See also:* Fantasy.

### **Bibliography**

- Abraham, Karl. (1927). The first pregenital stage of the libido. In *Selected papers of Karl Abraham* (Douglas Bryan and Alix Strachey, Trans.). London: Hogarth. (Original work published 1916)
- André, Jacques. (1994). *Sur la sexualité féminine*. Paris: Presses Universitaires de France.
- Freud, Sigmund. (1899a). Screen memories. *SE*, 3: 299–322.
- . (1905d). Three essays on the theory of sexuality. *SE*, 7: 123–243.
- Gessain, Robert. (1957). “Vagina dentata” dans la clinique et la mythologie. *Psychoanalyse*, 3, 247–295.
- Lewin, Bertram D. (1933). The body as phallus. *Psychoanalytic Quarterly*, 2, 24–47.

---

## **VALDIZÁN, HERMILIO (1885–1929)**

Hermilio Valdizán, a Peruvian psychiatrist, was born at Huánuco on November 20, 1885, and died in Lima on December 25, 1929.

Valdizán’s childhood was a difficult time: at the age of eight, following the death of his father, he went to Lima where he entered a charitable institution. Having enrolled for medical studies in the University of San Marcos in 1901, he worked as a teacher and journalist

while still a student. He graduated as a surgeon after presenting his thesis on “Delinquency in Peru” (1910). He went to Europe to study psychiatry and presented his doctoral thesis on “Mental alienation in primitives in Peru” (1915). Valdizán was the first Peruvian psychiatrist, strictly speaking.

He began his European studies essentially in Rome, where he encountered Sante De Sanctis, whose ideas were close to psychoanalysis. De Sanctis was particularly interested in the study of childhood and although he taught experimental psychology before obtaining the chair of neuropsychiatry, he integrated psychoanalytic ideas into his vision of clinical psychiatry. Back in Lima, Valdizán began to lecture on nervous and mental illnesses in the University of San Marcos. Javier Mariátegui wrote that in his lectures, “the stamp of psychoanalysis was everywhere manifest.” From 1918 he directed the Asilo-colonia de Magdalena—later renamed the Víctor-Larco-Herrera Hospital—where he organized psychiatric treatment in accordance with modern criteria. This hospital was long a pioneering arena in terms of psychiatric therapeutics and remained receptive to psychoanalytic ideas, particularly under Honorio Delgado.

Although not a psychoanalytic practitioner in the strict sense of the term, Valdizán deserves credit for initially giving great scope to the official teaching of psychiatry and for introducing into his courses on medical psychology the theme of psychotherapy, “as useful to today’s practitioner as any of the classic disciplines in vocational training.”

His most noteworthy contribution to psychoanalysis was the creation in 1918, with Honorio Delgado, of the *Revista de psiquiatría y disciplinas conexas* (Review of psychiatry and associated disciplines), which was the virtual mouthpiece for psychoanalytic thinking in Peru until 1924. Freud mentions it in “A Short Account of Psychoanalysis” (1924f [1923]) and in a 1924 addition to the note on chapter 2 of *The Psychopathology of Everyday Life* (1901b) where he quotes from Paul Wilson’s article “The Imperceptible Obvious” (1922).

Of Valdizán’s publications, those closest to psychoanalysis are “Extrapsychiatric Psychotherapy” (1918) and two articles written with Honorio Delgado: “Psychological Factors in Dementia Praecox” and “The Revolt of the Sexual Libido in Old Age.”

Valdizán’s main contribution to psychoanalysis is that he contributed to spreading the discipline at a

time and in a place where it gave rise to lively controversy. In 1930, after his death at the age of forty-four, the only chair of psychiatry in the country was taken by Honorio Delgado, who had by then become a fierce opponent of psychoanalysis. It is no idle speculation that Valdizán’s open-mindedness and tolerance with regard to psychoanalytic ideas would have favored their greater development.

ÁLVARO REY DE CASTRO

*See also:* Peru; *Revista de psiquiatría y disciplinas conexas.*

### **Bibliography**

- Mariátegui, Javier. (1981). *Hermilio Valdizán. El proyecto de una psiquiatría peruana*. Lima: Librería Minerva.
- Valdizán, Hermilio. (1918). La psicoterapia extrapsiquiátrica. *Anales, Facultad de medicina de Lima*, 250–271.
- . (1920). Ensayo de psicología del enfermo. *Revista de psiquiatría y disciplinas conexas*, 3, 1–2, 19–38.
- . (1923). Factores psicológicos de la demencia precoz. *Revista de psiquiatría y disciplinas conexas*, 4, 4, 263–286.
- . (1926). La rebelión de la libido sexual en la vejez. *Mercurio Peruano*, 9, 338–355.

---

## **VENEZUELA**

At the end of the 1950s there were two psychoanalysts in Caracas: Hernán Quijada, trained in Paris, and Guillermo Teruel, analyzed in London. The first reactions of associated groups (psychiatrists, psychologists) were varied, ranging from an attitude of refusal for some to curiosity and affiliation for others. Quijada’s important position in the Ministry for Health made it easier to receive state support.

Quijada, Teruel, Manuel Kizer, Antonio García, Fernando Acuña, Cesar Augusto Ottalagano, Julio Aray, Antonio Briceño, Nicolás Cupello, Hugo Domínguez, Juan Antonio Olivares, Hans Voss, and W. Hobaica formed a work group that was officially recognized by the International Psychoanalytical Association (IPA) at the Copenhagen congress in 1965. Between 1966 and 1969 an IPA committee comprising León Grinberg

and Maria Langer from Buenos Aires, Alfredo Nannum from Mexico, Luiz Guimarães Dalheim and Adelheid Lucy Koch from Brazil, worked at improving the group's training by revising theory and conducting group controls.

In 1969 the international committee appointed Teruel as the first training analyst. That same year, at the international Congress in Rome, the work group was transformed into a definitive association (Asociación Venezolana de Psicoanálisis; ASOVEP), prior to being affiliated to the International Psychoanalytical Association in 1971, at the Vienna Congress. The first group of candidates commenced training in 1969.

In May 1975 power struggles and exclusion anxiety gave rise to conflicts within the association between the oldest analysts and new arrivals. Two groups were formed with their respective orientations, calling for the intervention of the International Psychoanalytical Association at the London Congress in the same year. In 1976 a committee directed by Maxwell Gitelson and comprising Serge Lebovici, Daniel Widlöcher, Edward Joseph, and David Zimmermann went to Caracas to visit the association. Thanks to their intervention, the dissensions were soothed and a joint agreement was signed in 1977.

In 1983 Manuel Kizer, one of the founding members, left the ASOVEP to create a Lacanian group. In May 1989, after more quarrels, fifteen other members decided to constitute a separate group and received recognition as a work group from the International Psychoanalytical Association. This group went on to be recognized at the San Francisco Congress of 1995 as the Caracas Psychoanalytic Association.

The most noteworthy contributions from the ASOVEP includes J. Aray's work on the fetal psychism and abortion; Hugo Domínguez's study of the dynamics of communication; Alfonso Gisbert's work on the identity of the psychoanalyst; Rafael E. López-Corvo's study of femininity, addictions, and *auto-erividia* ("self-envy"); and Guillermo Teruel's work on the interaction between couples and the death instinct. From the Caracas Psychoanalytic Association, Addys Attías stands out for work on adolescent pathology, and A. Torres for work on feminine identification and neurosis.

There are therefore two associations in Caracas, each equipped with a training institute. In terms of publications, the ASOVEP review *Psicoanálisis* appears at irregular intervals, as well as a few monographs. The

Caracas Association publishes a twice-yearly review, *Trópicos*.

RAFAEL E. LÓPEZ-CORVO

### **Bibliography**

Olivares, Juan Antonio. (1984). Breve reseña histórica de la Asociación venezolana de psicoanálisis. *Psicoanálisis*, 1, 117–124.

---

## **VERTEX**

The term *vertex*, in Wilfred R. Bion's terminology, refers to the psychic place from which an emotional experience can be represented with the support of data from a sensory modality, which he called the "mental counterpart" (1965, p. 90) of the sense involved.

In common English, *vertex* has the more general meaning of "top." Bion introduced it into his terminology in 1965 in his book *Transformations: Change from Learning to Growth*. He was seeking an abstract definition of the "point of view" from which the mind, through a system of transformations, can bring emotional experiences linked to the absence of the object together into a "constant conjunction" (p. 96) and give them meaning. He thus used the geometric term *vertex*, "clothing" the abstract geometric concept in imaginary flesh. In so doing, he sought to avoid two pitfalls: that of using a term with strong metaphoric connotations such as *point of view*, which privileges the sense of sight, and that of reducing the libidinal objects and their processes of intrapsychic transformation to purely formal entities. He nevertheless recognized the primacy of the sense of sight in these processes of transformation, notably, that it leads more readily to verbal description than the other senses. While he emphasized this primacy, he nonetheless showed that a change of vertex, or the mental equivalent of a sensory modality, can be necessary to represent certain psychic experiences. He also described the reversal of a vertex; for example, the reversal of the visual vertex that leads to hallucinations.

Bion used the concept of the vertex to describe the relationship between patient and analyst and to propose a theory of interpretation. In the analytic rela-

tionship, patient and analyst share the same experience, but each has a different vertex. The patient's vertex is linked to his or her unconscious motivations and their corresponding emotional bonds, the H (hatred) bond or the L (love) bond. The analyst must strive to adopt a vertex that is linked only to the K (knowledge) bond, the emotional bond corresponding to the psychic tension that must be tolerated until meaning emerges. Interpretation for the analyst consists of formulating, when the time comes, his or her experience of the situation based on this vertex. The vertices of the patient and the analyst must be neither too close nor too far apart from one another. This produces a "binocular vision" that enables the patient to take a step back from his or her original vertex, bringing a sort of perspective into the patient's psyche.

DIDIER HOUZEL

See also: Bion, Wilfred Ruprecht; Invariant; Transformations.

### **Bibliography**

Bion, Wilfred R. (1965). *Transformations: Change from learning to growth*. London: Heinemann.

———. (1970). *Attention and interpretation*. London: Tavistock.

Grinberg, Léon, Sor, Dario, and Tabak de Bianchedi, Elizabeth. (1977). *Introduction to the work of Bion: Groups, knowledge, psychosis, thought, transformations, psychoanalytic practice* (Alberto Hahn, Trans.). Northvale, NJ: Jason Aronson. (Original work published 1973)

---

## **VIDERMAN, SERGE (1916–1991)**

The Romanian-born French physician, psychiatrist, and psychoanalyst Serge Viderman was born on September 15, 1916 in Rimnic-Sarat, near Bucharest, and died in Paris on November 3, 1991.

The third of four brothers, he was born into a relatively affluent family; his father was a forestry agent. After his secondary education, without prospects owing to the numerous *clausus* against Jews, he decided to go to France to join his eldest brother, who had established himself as a doctor there. He arrived in Rouen in 1934, at the age of eighteen, and entered medical school, perhaps less out of any sense of vocation than of lack of interest in the second career option then available to gifted Jews: the legal profession.

With the outbreak of the war, he finished his studies and, after escaping imprisonment for resistance activities, he took refuge in Grenoble, in the free zone, where he rejoined his brother and his family and enrolled in the bachelor's program in philosophy at the university. In 1943 he was forced to flee again, this time to Paris, where he lived under a false identity until the Liberation.

After the Liberation he became a naturalized French citizen, but, in need of money, he accepted a job in Fribourg (Switzerland) at the National Office of Immigration. Based on the conclusions of his medical examination, "displaced persons" were directed toward either France or the United States. It was here that he met his future wife, Michèle, who came from Burgundy; the couple had three daughters.

As soon as he was able, Viderman returned to France and settled near Poitiers, where the mayor of a small administrative district was in need of a doctor and was offering lodging. Unenthusiastic about being a country doctor, he then moved to settle near Rouen as a generalist in order to be closer to Paris and the practice of psychiatry.

He came into renewed contact with his compatriot Béla Grunberger, who recommended his own psychoanalyst, Sacha Nacht; like both of the other men, Nacht was a Romanian Jew. Viderman entered analysis with Nacht in the spring of 1952, and after another move, this time to the Paris suburbs, in 1955 he found a job as a psychiatrist at Villa-des-Pages clinic, in Le Vésinet, which was headed by two doctors named Leulier; this enabled him to cut his first teeth as a practicing psychiatrist.

His name did not appear on any of the lists of "students in training" that were fought over by the two rival factions of the schism of 1953, but his performance in his degree course was brilliant enough for him to be entrusted, in 1956, with writing, under Nacht's direction, an important article entitled "Aperçu sur l'histoire de la littérature psychanalytique" (Outline of the history of the psychoanalytic literature) for the second volume of *La Psychanalyse d'aujourd'hui* (Psychoanalysis today), published by the Presses Universitaires de France. In this article he painted a broad historical picture that equally embraced child analysis and psychosomatic theories, and he showed no hesitation in approaching the contemporary era, with Nacht ("Nacht's work stands out

for its precision and clear organization”), Maurice Bouvet (whose report on object relations he cited as one of the “studies full of promise that have been published in France in recently years”), Daniel Lagache, whose “substantial report” on transference was noted, and Jacques Lacan, “who has published works written in a singular style, the obscurity and preciousness of which are detrimental to his thinking” (Viderman also rebuked Lacan for failing to cite Henri Wallon, in whose works “he had nevertheless found the clearest part of his inspiration”).

Esteem for Viderman was confirmed by his election to membership in the Société psychanalytique de Paris (SPP; Paris Psychoanalytical Society) in December 1957. After Bouvet’s death in 1960, Viderman was immediately accredited to take over his training analyses; unsurprisingly, he was elected to permanent membership in the society on October 18, 1960. At this time he left the clinic at Le Vésinet and settled definitively in Paris as a psychoanalyst.

Viderman’s position within the institution was always that of a “critic” in the true sense—a position, moreover, that was congruent with the theoretical and clinical views he elaborated over time. He felt close to those who were attempting to open up the SPP to the outside, particularly to the analysts of the Société française de psychanalyse (French Society of Psychoanalysis), which would become the Association psychanalytique de France (Psychoanalytic Association of France), but also, whatever reservations he may have harbored about Lacan, with regard to what he perceived to be lively elements within the Lacanian movement. For example, in 1967 he wrote for *L’Inconscient*, the revue founded by Piera Aulagnier, Jean Clavreul, and Conrad Stein. Although he was one of the founders and, from 1973, codirectors, along with Christian David and Michel de M’Uzan, of the general section of the collection “Le fil rouge” (The red thread) published by the Presses Universitaires de France, he also long maintained close ties with René Major and Dominique Geahchan in the meetings organized by their group, *Confrontation*, from 1974.

In 1978–1979 he tried, although in vain, to promote a “second degree program,” known as *Cursus B*, alongside the traditional curriculum for the training of analysts within the Institut de psychanalyse de Paris (Paris Institute of Psychoanalysis). In 1979 he cosigned the summons issued to the institute by Robert Barande, Dominique Geahchan, René Major, Michel Neyraut

and Conrad Stein to try to annul expulsion orders judged to be illegal and voted for in June, against members who refused to pay their membership fees in protest. Finally, in 1980 he found himself alongside Geahchan, François Roustang, Jacques Sédat, and Stein, among the promoters of the foundation of the Collège des psychanalystes (Collegium of psychoanalysts), which aimed to situate itself “outside of the traditional structures of psychoanalytic societies.”

These stands taken in relation to institutions were not arbitrary, but rather closely linked to the ideas Viderman promoted; these ideas first appeared in fully developed form in his book, *La Construction de l’espace analytique* (Construction of the analytic space; 1970), which marked a real turning point in the thinking of many analysts in the French psychoanalytic community. His ideas incited lively discussions that for a time seemed to take precedence over the usual administrative quarrels. They were viewed as subversive by adherents to a dogmatic psychoanalysis that was dependent upon a certain Freudian scientific ideal, and conducive to the exercise of a will to codify, whose sterility and absurdity Viderman underscored.

His description of the space in which an analytic relationship (which is always an invention in partnership) is born, flourishes, and fades away, is based on a radical putting into doubt of the existence of any external “truth” that could be found in its integrity and could transcend the protagonists in the relationship. The person of the analyst and the counter-transference here have a dimension that renders practice less assured and less reassuring. Interpretations do not “construct” the subject’s history, but rather “construct” a probability that cannot pretend to be an “objective historical truth.” Needless to say, this calling into question of pseudo-certainties was taken for what it was: a relativization of the “power” of those who pretended to legislate in their own name, a caution against the abuses of force in producing meaning.

Book after book, Viderman deepened his explorations, for example with *Le Céleste et le Sublunaire* (The celestial and the sublunar; 1977), or *Le Disséminaire* (The disseminary; 1987), where he pursued his task by dismantling the illusions—extremely similar illusions, in the last analysis, because they are linked to the same sociocultural sources—that inspired the thinking of Freud, Marx, and Einstein, all of whom believed in the existence of a rigorous determinism, a law that orders the tangible world and the psyche alike. For him, the

path was cleared in process, with the passage of the person who walked it.

Viderman did not live to see the publication of his last book, *De l'argent en psychanalyse et au-delà* (Money in psychoanalysis and beyond). It could not be fitted into the publication schedule at the Presses Universitaires de France until shortly after his death, on November 3, 1991, of a cancer that had gradually distanced him from all activity other than writing. It is an incomplete book, not revised with Viderman's characteristic meticulousness, for those close to him had tried, in vain, to get it printed before time ran out, as they knew it was fated to do. Death, moreover, is a constant presence in this work, which gives the sense of a testament, but in reality completed the approach Viderman had begun twenty years earlier. His way of emphasizing our fear of nothingness and the "illusory conjuration" of it represented by money reveals the contours of a meditation on human destiny as well as on the psychoanalyst's place in this process; the book attests to the abiding presence of the philosophical reflection that filled the first years of his training.

As Michel Neyraut wrote in his 1991 obituary for Viderman, printed in *Le Monde*: "Out of the humanist, the thinker, the linguist, the gourmet, the sage, and finally, the psychoanalyst, which was dominant in him? It depended on whether you were asking about a passage from Homer, the bouquet of a Médoc, a translation of Vialatte, or simply the meaning of a word—he, who came from Romania and had learned his French out of Anatole France!"

ALAIN DE MIJOLLA

See also: Nacht, Sacha; Société psychanalytique de Paris et Institut de psychanalyse de Paris.

### Bibliography

- Neyraut, Michel. (1991, November 7). Nécrologie de Serge Viderman. *Le Monde*.
- Viderman, Serge. (1970). *La construction de l'espace analytique*. Paris: Denoël.
- . (1977). *Le céleste et le sublunaire*. Paris: Presses Universitaires de France.
- . (1987). *Le disséminaire*. Paris: Presses Universitaires de France.
- . (1992). *De l'argent in psychanalyse et au-delà*. Paris: Presses Universitaires de France.

## VIENNA, FREUD'S SECONDARY SCHOOL IN

After home-schooling and studies at a private primary school during his elementary school years, in 1865 Sigmund Freud enrolled in the first class of the newly constructed Leopoldstädter Kommunalrealgymnasium, and later (1868–1869) at the Obergymnasium, located at Taborstrasse 24 in the second district in Vienna. He completed the degree course, earning high praise, received the school prize in his third year, and in 1873, in his eighth year, received the *Matura* (high-school diploma) with honors after passing his qualifying exams. These included: composition, in German, on the theme "What considerations should guide us in choosing a profession?"; Latin exam: Virgil, Book IX, 176–223; Oskar Seyffert, book XIII"; Greek exam: Sophocles, *Oedipus Rex*, v. 14–57; and mathematics.

The ratio of Catholics to Jews in the second-year class was thirty to twenty-eight; in the eighth-year class it was six to five. As to anti-Semitism in the upper classes, from Freud's fifth year, the name "Sigmund" appears on school documents instead of "Sigismund," probably because of ridicule; otherwise there are no traces of an administrative change of his first name.

There are numerous allusions to Freud's secondary-school years in his scientific works, particularly in *The Interpretation of Dreams* (1900a), for example, the dream of the botanical monograph. His esteem for his high school teachers never diminished: Samuel Hammerschlag, who taught religion and was also librarian to the Jewish community and a friend of Freud's father; Viktor Ritter von Kraus, who taught German, history, and philosophy.

During his eighth year (university preparation), Freud was at the head of his class. His friends included Heinrich Braun, Wolf Knöpfmacher, Salomon Lipiner, Siegmund Lustgarten, Ignaz Rosanes, Eduard Silberstein, Julius Wagner, and Richard Wahle.

Freud contributed to the school's fiftieth anniversary celebration, in 1914, with an article, "Some Reflections on Schoolboy Psychology," that appeared in the commemorative brochure. For the fiftieth anniversary of Freud's death in 1989, the Erzherzog Rainer Realgymnasium was renamed the Sigmund Freud Gymnasium.

EVA LAIBLE

See also: Adolescence; Darwin, Darwinism, and psychoanalysis; Psychology and psychoanalysis; Silberstein, Eduard; Suicide.

### Bibliography

Freud, Sigmund. (1900a). The interpretation of dreams. *SE*, 4–5.

———. (1914f). Some reflections on schoolboy psychology. *SE*, 13, 239–244.

Laible, Eva. (1989). Über Sigmund Freuds Gymnasialzeit, 125 Jahre Bg./ B.R.G. Wien II. *Festschrift Sigmund Freud, dem berühmtesten Schüler unseres Gymnasiums zur 50. Wiederkehr seines Todestages gewidmet* (pp. 19–30). Vienna: Festschrift Sigmund Freud.

Pokorny, Alois. (1865). *Jarhesberichte des Leopoldstädter Kommunal-Real- und Obergymnasiums in Wien. Wien 1865–1874*. Vienna: Verlag des Leopoldstädter Real- und Obergymnasiums.

---

## VIENNA GENERAL HOSPITAL

Originally a hospice for the poor, Vienna General Hospital (Allemeines Krankenhaus) was dedicated by Emperor Joseph II in 1784. With about two thousand beds and a design with courtyards and open spaces, the hospital by the 1870s had become one of Europe's leading teaching hospitals, with new and expanding departments and clinics.

After receiving his medical degree in March 1881, Freud was able for a time to continue his research in Ernst Brücke's physiology laboratory, where he also worked as a demonstrator for several semesters. But because Freud had limited financial resources, his hopes of building a career in research were misplaced, and Brücke's attempts to obtain a research position for him in laboratories in Graz and Prague proved fruitless. After becoming engaged to Martha Bernays in June 1882, Freud accepted Brücke's advice to give up research in favor of a more remunerative career as a physician. A month later Freud began his clinical training at the Vienna General Hospital.

Freud spent three years at the hospital and trained in many of its different departments. He worked in surgery (July to September 1882) and studied internal medicine under Hermann Nothnagel (October 1882 to March 1883). His early training in psychiatry was under Theodor Meynert (April to October 1883). Freud subsequently trained in the dermatology clinic and was assigned to the ward for syphilitic patients. At first an unpaid trainee, Freud was appointed assistant physician (*Sekundararzt*) while under Meynert, and in early 1885

he temporarily replaced Franz Scholz as head of the department of nervous diseases and the liver. At the same time, he continued his researches in brain anatomy and pathology in Meynert's laboratory. He published numerous articles in clinical neurology, on brain pathologies, and on cocaine, and for extra income he wrote abstracts of articles in international medical journals.

Freud specialized in nervous diseases on the advice of Josef Breuer, and in June 1885 he was appointed privatdozent in neuropathology. About the same time, with Brücke's support, he obtained a postgraduate travel grant to study in Paris at Salpêtrière Hospital with Jean Martin Charcot. He subsequently concluded his clinical training in Berlin at Adolf Baginsky's pediatric clinic. After his return to Vienna, he established a private practice as a neurologist in April 1886 and married in September of the same year.

EVA LAIBLE

*See also:* "Autobiographical Study, An"; Breuer, Josef; Brücke, Ernst Wilhelm von; Meynert, Theodor; Vienna, University of.

### Bibliography

Freud, Sigmund. (1960). *Letters*. New York: McGraw-Hill.

———. (1960b [1885]). Curriculum vitae. In Josef Gicklhorn and René Gicklhorn, *Sigmund Freuds akademische Laufbahn im lichte der dokumente*. Vienna: Urban und Schwarzenberg.

Hirschmüller, Albrecht. (1991). *Freuds begegnung mit der psychiatrie*. Tübingen, Germany: Diskord.

---

## VIENNA PSYCHOANALYTIC SOCIETY. *See* Wiener Psychoanalytische Vereinigung

---

## VIENNA, UNIVERSITY OF

After a series of lectures on Darwin by Carl Brühl (1820–1899), an eminent professor of zoology at the University of Vienna, Freud decided to study medicine rather than law and to become a researcher in order to "understand something about the enigmas of nature



and perhaps even contribute to solving them.” His decision was also inspired by “Nature,” a text that has been attributed to Goethe. In the absence of faculties in the natural sciences, medicine substituted as basic training for biologists, zoologists, and physiologists. Freud, however, had no wish to become a physician. The freedom in organizing studies accorded by the edicts of 1872 suited his theoretical penchants.

Prepared by exercises with the microscope, he engaged for six semesters in intensive studies of zoology with Carl Claus (1835–1899), a Darwinian. Claus twice sent him on a university grant to the zoological station at Trieste, Italy, to study the sexual organs of the eel. Although Freud himself underestimated the value of this research, his description of the bisexual disposition of the fresh-water eel is considered a fundamental study in this domain. His studies of Aristotle with Franz von Brentano (1838–1917) caused him to nurture for some time the notion of doing a double doctorate in zoology and philosophy.

In the course of his seventh semester he moved away from Claus, an exceptional though not very directive master, and joined the laboratory of the physiologist Ernst Wilhelm von Brücke (1819–1892), who was assisted by Ernst Fleischl von Marxow (1846–1891) and Siegmund Exner (1846–1926). This was “the inexhaustible center that drove all Viennese medicine in the second half of the century,” where Freud finally found “tranquility and total satisfaction,” as well as individuals that he could “respect and take as models.” Brücke was an outstanding figure whom Freud could identify with, like Jean Martin Charcot later.

Being more of a researcher than a student, Freud published five articles on neurophysiology before his doctorate. With “Über den Bau der Nervenfasern und Nervenzellen beim Flusskrebs” (On the structure of nerve fibers and cells in the crayfish) in 1882, he became a pioneer in neurological research. He nevertheless experienced failures in his work in the Institute for Experimental Pathology, headed by Salomon Stricker (1834–1898), and in the Chemistry Institute, run by Ernst Ludwig (1842–1915).

In 1879 and 1880 he translated works of John Stuart Mill, published in volume 12 of Mill’s *Gesammelte Werke* (Complete works), in order to earn his living, since he found himself in a difficult financial situation in spite of grants from two Jewish organizations. At this time he did his military service while preparing for his doctorate. In the oral examinations for his doctorate he received

grades of “excellent” for the first and third examinations and a grade of “good enough” in the second. He sat for a recapitulation exam in law for physicians and received his medical doctorate on March 31, 1881. Among his friends while he was a student were Carl Koller, Siegmund Lustgarten, and Eduard Silberstein.

EVA LAIBLE

*See also:* Amentia; Brentano, Franz von; Breuer, Josef; Brücke, Ernst Wilhelm von; Darwin, Darwinism, and psychoanalysis; Goethe and psychoanalysis; Hard science and psychoanalysis; Institut Max-Kassowitz; Internal/external reality; Philosophy and psychoanalysis; Science and psychoanalysis; Silberstein, Eduard; Wagner-Jauregg, Julius (Julius Wagner Ritter von Jauregg).

### **Bibliography**

- Hemecker, Wilhelm. (1991). *Vor Freud: philosophiegeschichtliche Voraussetzungen der Psychoanalyse*. Munich, Germany: Philosophia.
- Laible, Eva. (1993). Through privation to knowledge: unknown documents from Freud’s university years. *International Journal of Psycho-Analysis*, 74, 4, 775–790.
- Lesky, Erna. (1976). *The Vienna medical school of the 19th century* (L. Williams and I. S. Levij, Trans.). Baltimore, MD: Johns Hopkins University Press. (Original work published 1965)

---

## **VIOLENCE, INSTINCT OF**

The word *violence* derives from an Indo-European root that refers to life. The natural instinct of violence is thus not a destructive instinct, much less a death instinct, but a natural life and survival instinct that corresponds to the instinct of self-preservation in Siegmund Freud’s first theory of the instincts.

It involves what Freud saw as a sort of natural “imaginary cruelty” in 1897 and described in “Instincts and Their Vicissitudes” (1915c) as being common to humans and animals. This instinct’s goal is above all to protect life and the narcissistic integrity of the subject. This holds regardless of the potential effects caused secondarily to an object that as yet has only a narcissistic status in the subject’s imagination. Instinctual violence has nothing to do with aggressiveness, sadism, or hatred, whose libidinal components Freud showed to be aimed at an object that had otherwise attained an oedipal genital status.

In *Three Essays on the Theory of Sexuality* (1905), Freud very clearly showed that this brutal instinct can attract to itself a part of the sexual instincts, producing aggressive components. In 1915 he attributed a narcissistic and phallic character to violent dynamism and advanced the hypothesis of a logically necessary anaclysis of the sexual instincts on the brutal self-preservation instincts, so as to reinforce the energy of the sexual instincts in the direction of love and creativity.

The role of the instinct of violence was gradually specified in European and American psychoanalytic studies that since 1960 have focused on a veritable metapsychology of narcissism. In *La Violence fondamentale* (Fundamental violence; 1984) Jean Bergeret, based on such studies and Freud's first hypotheses, proposed an attempted synthesis, forming a theory of instinctual violence. He gave special emphasis to the difficulties Freud encountered in trying to account for the stage of primitive violence within the totality of the Oedipus myth. The first acts of the drama (the oracle of Apollo and the episode of Mount Cithaeron in particular) bear witness to human beings' deep intuitive awareness of their fundamental instinct of brutality in the service of self-preservation.

Freud was never satisfied with his successive theories about the instincts. Rather, he decided to focus on the synchronic aspect of a conflict arising between tendencies within the same psychogenetic generation. His theory of instinctual anaclysis, however, would have enabled him to conceptualize a diachronic conflict pitting the violent pregenital tendencies against the sexual tendencies, with all the possible configurations linked to fusion, defusion, and the different modes of articulation of these two fundamental groups of instincts. His choice of a synchronic model of conflict prevented Freud from better integrating into his psychodynamic and economic conception this brutal instinct of violence and defense, which he had nevertheless clearly described.

JEAN BERGERET

*See also:* Aggressiveness/aggression; Catastrophic change; Combined parent figure; Criminology and psychoanalysis; Cruelty; Envy and Gratitude; Fort-Da; Mastery, instinct for; Phobias in children; Primal scene; Sadism; Stammering; Transgression.

### **Bibliography**

- Bergeret, Jean. (1984). *La violence fondamentale*. Paris: Dunod.
- . (1994). *La violence et la vie*. Paris: Payot.

Freud, Sigmund. (1905d). Three essays on the theory of sexuality. *SE*, 7: 123–243.

———. (1915c). Instincts and their vicissitudes. *SE*, 14: 109–140.

---

### **VIOLENCE OF INTERPRETATION, THE: FROM PICTOGRAM TO STATEMENT**

The *Violence of Interpretation*, originally published in 1975 by the Presses Universitaires de France, was Piera Castoriadis-Aulagnier's first book, although she had already published a number of important articles beginning in 1961, and her research (seminar at the Hôpital Sainte-Anne), institutional involvement (creation of the Quatrième Groupe of the O.P.L.F. in 1969), and editorial work (as head of the revue *L'Inconscient* and, then, *Topique* beginning in 1969) were already widely known.

This book marked an important step in psychoanalysis in France, especially with regard to psychosis. It attracted a huge readership immediately, and has been translated into Italian, Spanish, Portuguese, and English.

Aulagnier's project sought to reexamine the Freudian metapsychological model on the basis of the psychoanalyst's obligation, in therapeutic work with psychotic patients, to rethink the mind and its models. The magnitude of the task and the systematic organization of the new theories presented explain why this book was published relatively late in her career.

*The Violence of Interpretation*, according to Aulagnier, attests to the "prodigious work of reinterpretation carried out by psychosis" (p. xxviii) and thus makes it possible to catch a glimpse of an unthinkable "before" that has been shared by all. Aulagnier did not base her work on the idea of a "psychotic kernel" common to all, a theory she rejected, but rather believed that the psychotic succumbs to the attraction of a mode of representation that has normally been surpassed, even though it remains latent in all subjects. The author's analysis thus culminated in a theory of representation, and more specifically of what she called a "primal" stage of representation, which "ignores word-presentations and has as its exclusive material the image of the physical thing" (p. xxix). Hence Aulagnier's definition of psychosis: "Psychosis is characterized by the force of attraction exerted by the primal, an attraction to which it opposes that 'addition' represented by the creation of a 'delusional' interpretation that makes 'sayable' the effects of that violence" (p. xxx).

Aulagnier innovated a number of new concepts based on this precept, in particular “primary violence,” which is the effect of anticipation imposed by the discourse of the mother (“word-bearer”) upon an *infans* from whom a response is anticipated that the preverbal infant is unable to give, and the “secondary violence” that “leans on” the first.

For Aulagnier psychic activity is subdivided into three modes of functioning, none of which necessarily silence one another: primal process (pictographic representation), primary process (fantasy representation), and secondary process (ideational representation).

The phenomenon of specularization (Jacques Lacan) and the psyche’s “borrowing” from sensory models are characteristic of the primal process. The “pictogram” is defined as “the formation of a relational schema, in which the representative is reflected as a totality identical with the world” (p. 25). This “representative background” does not disappear from the subject, but is “foreclosed to the power of the I’s knowledge” (p. 37), except in psychosis where it is manifest.

The primary process is comprised of fantasy activity, but Aulagnier emphasized that pleasure and unpleasure are always experienced here as being dependent upon an Other’s desire to give or refuse it.

Finally we have the secondary process, which is linked to the appearance of word-presentations. Nomination, once it involves affect, means naming not just the object, but also the relation that links the I to the object: “to name the other with the term beloved is to designate the subject who is naming as lover” (p. 97). The I’s self-naming, with the linguistic signs proper to affect and the kinship system, enable it to come into being. Aulagnier wrote: “The I is simply the I’s knowledge of the I” (p. 5), but the I is also constructed: in relation to its past in “self-historization” and to its future in the “identificatory project.”

The conditions that make it impossible for an I to come into being other than by passing through delusional identification are the topic of the second part of the book, where the author defines what she means by the “psychotic potentiality” or “primary delusional thinking” that can (or cannot) give way to actual psychosis.

Aulagnier developed the two major categories of schizophrenia and paranoia and, based on the hypothesis of secondary violence and delusional theories of

origination, proposed a new psychoanalytic approach to these pathologies.

SOPHIE DE MIJOLLA-MELLOR

*See also:* Aulagnier-Spairani, Piera, France; Infans; Object; Pictogram; Psychotic potential; Sense/nonsense.

### Source Citation

Aulagnier, Piera. (2001) *The violence of interpretation: From pictogram to statement* (Alan Sheridan, Trans.). Hove, UK, and Philadelphia: Brunner-Routledge.

---

## VISUAL

As an adjective, the term *visual* designates what is perceptible in the field that presents itself to the eye. As a noun, *the visual* involves the way in which the psychological apparatus organizes this perceptual data.

As early as his study on aphasia (1891b), Freud emphasized the importance of the visual in the representation of things in order to understand its complicated relationship with representation by words. In *The Interpretation of Dreams* (1900a), he both provided an optical model for the psychical apparatus and also noted that the dream material, as well as that of memory traces, are most often presented visually. Thus, modes of representation must fulfill requirements of visual representations. The subsequent recognition of visual component drives provided Freud with the opportunity to verify that their vicissitudes are not homologous to those of the other drives. Finally, in *Moses and Monotheism* (1939a), he insisted that it was necessary to set aside visual stimuli, especially those caused by the maternal body, in order to name the father. He connected this “advance in intellectuality” (1939a, p. 111) to the impact of monotheistic religion on mental life, especially when it prohibits representations.

In Freud’s work, the visual shows the privileged connection between the sexual and the sensorial. Jacques Lacan discussed this in his article on the “Mirror Stage” (1949), where he expanded Freud’s observations of the visual dimension of narcissism. Lacan stressed the importance of the mirror image for the infant held up to the mirror by its mother. When the baby recognizes itself in the mirror, it achieves an identity by assuming the mirror image. But this is also a trap, because once the subject is captured, he confuses himself with the mirror image and thus becomes alie-

nated by a visual definition of self. He is caught in the succession of images.

In a study relating psychotic discourse to the mirror stage, Piera Aulagnier proposed that in the psyche's primal activity of visual representation its invested object should be called a *pictogram*. In doing so, she emphasized the prevalence of the visual in unconscious representations.

It is worthwhile to make another distinction between the visible image and the visual image. Vision exhausts only the empirical reality of a phenomenon, which can become a psychic representation, that is, a visual image, only by passing through the primary and secondary processes. The difference between what is visible and the *visual* of the image explains how dream images are never confused with things seen by the dreamer. Because it is incongruous with the desire to see, the visual image assures the perpetual thrust of the scopic drive. The impossibility of reducing the visual to the visible prevents the image from showing the object of desire and orients vision towards another image. If we grant Freud's assertion that the desire to see is related to seeing the genital organs, the notion of the visual allows us to specify what is involved in the attempt to see, namely the female genitalia that eludes sight. The only way to represent it is by the visual image, which is a fetish that only exposes its unreal opposite, the maternal penis.

Why is the visual the predominant sense? This question can be answered by considering that the visual is overdetermined because there is no penis on the female body. When the child fails to see a penis on a female body, his single sex wavers and he begins to think that there is another sex, which exists even though it is "invisible." Other elements of the visual deserve further attention. For example, the central role that psychoanalysis grants the visual is justified by the fact that there must be a visual reference, a virtual psychical mirror (certain moments in the treatment) or a visual fantasy. The determining function of the visual might be related to the timelessness of the unconscious, because only the visual is in a position to prevent the representation of the fantasy from being eternalized.

JEAN-MICHEL HIRT

*See also:* Alpha elements; Amphimixia/amphimixis; Dream screen; Dream work; Fort-Da; Functional phenomena; Hallucinoses; Look/gaze; Mnemic trace/memory trace; Organic repression; Perception-consciousness (Pcpt.-Cs.); Psychic envelope; Psychic temporality;

Representability; Secondary elaboration; Screen memory; Smell, sense of; Sudden involuntary idea; Thing-presentation; Thought; Voyeurism.

### **Bibliography**

Aulagnier, Piera. (1975). *La violence de l'interprétation. Du pictogramme à l'énoncé*. Paris: Presses Universitaires de France.

Freud, Sigmund. (1900a). The interpretation of dreams. *SE*, 4–5: 1–751.

———. (1939a [1934–38]). Moses and monotheism: Three essays. *SE*, 23: 1–137.

Lacan, Jacques. (2002). The mirror stage as formative of the I function as revealed in psychoanalytic experience. In *Écrits: A selection* (Bruce Fink, Trans.). New York: W. W. Norton. (Original work published 1949)

---

## **VISUAL ARTS AND PSYCHOANALYSIS**

The visual arts make use of nonverbal representation and therefore require a different psychoanalytic approach than the language arts. The work of art can be considered as a compromise solution between impulses and defenses. Psychoanalysis can then try to reveal the unconscious ideas behind the creative work. But in the visual arts, even more so than in the language arts, it is form itself, more than the represented subject, that must be interpreted.

The first psychoanalytic text to examine the visual arts was Freud's *Leonardo da Vinci and a Memory of his Childhood* (1910c). Freud opened the way for psychobiography by demonstrating the impact of instinctual and infantile life on the artist's creative work. In his analysis of La Gioconda and Saint Anne, he approached the analysis of formal elements: the Gioconda's enigmatic smile owes its existence to Leonardo's infantile life; the confusion of the bodies of Anne and Mary in the London drawing is said to be a form of condensation.

In 1911 Karl Abraham published an essay on Giovanni Segantini. His goal was to show that psychoanalysis can be applied to the analysis of mental processes other than neurosis. He demonstrated the role of the practice of making art in the psychic economy of the artist, the importance of infantile experience, real or imagined, and the antagonistic interplay of love and hate in the genesis of the work. Unfortunately, his analysis of the paintings themselves does not deepen the interpretation of the manifest subject of the representation.

In 1913 Otto Rank and Hanns Sachs published in *Die Bedeutung der Psychoanalyse für die Geisteswissenschaften* (Psychoanalysis and the humanities) a chapter on the aesthetics and psychology of art, centered on the affects of pleasure and unpleasure of the work of art. They argued that the economy of affect governs the development of the formal aspects of the work of art.

Freud published “The Moses of Michelangelo” (1914b) but did not sign it, proof of his prudence in using psychoanalysis for the interpretation of artistic phenomena. Freud based his interpretation of the statue on his own feelings. Since he identified with the subject of the representation, he understood the statue in terms of his own emotional investment, thus opening a path to an approach to artistic phenomena that was little used by later psychoanalysts, who were primarily interested in an analysis of the process of artistic creation. There were a number of important contributions to this field aside from the work of Freud: Otto Rank, Melanie Klein, Hanna Segal, Ernst Kris, Donald Winnicott, and Didier Anzieu.

Children’s drawings and the work of psychotics have been used as nonverbal material, but strangely they have had little influence on the psychoanalysis of the visual arts. This field owes a great deal to the work of artists and art historians like Anton Ehrenzweig, Meyer Schapiro, Jean Clair, and René D emoris, who have made use of psychoanalytic theory. Along with the approach taken by psychobiography and interpretations of the creative process, both of which are focused on the artist, psychoanalysis can also help us understand the work of art itself, providing it can avoid using verbal language as the only source of reference. When Freud wrote that the lack of expression of the visual arts was due to the material used by those arts, he was referring to this.

The image is not only a metaphor or symbol; it signifies, through its materiality, the setting aside of its metaphoric or symbolic meaning and the context in which our perceptual field has classified it. It comes to prominence through the brilliance of its materiality as a new external perception that we nonetheless are able to recognize. For the visual arts much more than for literature, meaning is hidden in form, the result of the conscious and unconscious intentions of the author.

It is in the formal specifics of the work—that is, its style—that the process of figuration unique to the author is found. This is what Freud called, referring to the dream work, “pictorial language,” our first mode of

expression. The painted or sculpted image should not be considered only the transcription of verbal thought but the expression of a visual unconscious that preserves our earliest impressions. The artist uses a sensory material that bears the traces of his first affective perceptions and experiences, producing a figurative representation that balances desire with external reality, actual perception with what has been irremediably lost.

The psychoanalytic approach to the arts requires a methodology first used by Freud in “The Moses of Michelangelo.” The effect the work has on the spectator is the object of analysis. The image must be considered a libidinal object of investment that is offered to the spectator and apprehended on the basis of the effects it provokes in him. The work of art reactivates the spectator’s unconscious desire and awakens, step by step, the representations he has used as a support. Through this associative process, the spectator-analyst juxtaposes the resonances the work provokes in him and the formal aspects that can be considered traces of the unconscious life of its author. It is through this chain of association that he will be able to reconstruct the fantasies that generated the work of art.

MICHEL ARTIÈRES

*See also:* Baudouin, Charles; “Claims of Psychoanalysis to Scientific Interest”; Literary and artistic creation; Illusion; Kris, Ernst; *Leonardo da Vinci and a Memory of his Childhood*; “Moses of Michelangelo, The”; Rank (Rosenfeld), Otto; Representability; Sublimation.

### **Bibliography**

- Anzieu, Didier. (1981). *Le corps de l’œuvre, essais psychanalytiques sur le travail créateur*. Paris: Gallimard.
- Artières, Michel. (1995). *Cézanne ou l’inconscient maître d’œuvre*. Lausanne: Delachaux and Niestlé.
- Freud, Sigmund. (1914b). The Moses of Michelangelo. *SE*, 13: 209–238.
- Kris, Ernst. (1952). *Psychoanalytic explorations in art*. New York: International Universities Press.
- Schapiro, Meyer. (1994). *Theory and philosophy of art: Style, artist, and society*. New York: George Braziller.

---

## **VOYEURISM**

Voyeurism is a deviant manifestation of sexuality that involves looking without being seen in order to obtain

sexual pleasure. In *Three Essays on the Theory of Sexuality* (1905d), Freud examines sexual perversion and indicates the circumstances under which “the pleasure of looking [scopophilia] becomes a perversion (a) if it is restricted exclusively to the genitals, or (b) if it is connected with the overriding of disgust (as in the case of *voyeurs* or people who look on at excretory functions), or (c) if, instead of being *preparatory* to the normal sexual aim, it supplants it.”

Later, in “Instincts and Their Vicissitudes” (1915c), he provided a metapsychological explanation for the instinct of looking, which involved the voyeur-exhibitionist pair and the reversal of activity into passivity in connection with a precise object: “the sexual member.” The different instinctual currents of seeing are inflected by the voyeur, who tries to see the other’s genitals while hiding his own, but who also tries to be seen looking, in order to respond to what he believes is the other’s desire to see. Jacques Lacan would later say that the voyeur wants to be seen as a seer.

Freud continued to emphasize the visual component of the perversions, but for him the specificity of voyeurism is important because of the vicissitude of the instinct of looking rather than its role in perversions. Rather than allowing the evolution of the instinct (component) of looking to develop in different directions, the voyeur reduces the sexual and the visual in sex to a narrow, stereotypical sexual situation. He appears to do away with the sexual, the multiplicity of objects and choices, by wrapping them in a rigid fantasy. He tries to block the aggression in the instinct in order to obtain pleasure, to the detriment of the other. By splitting the ego, he uses sex for the purpose of discharging instinctual violence. By appropriating the other as image, the voyeur makes it an object of pleasure, while remaining uninvolved in the other’s intimacy. The voyeur does not seek any form of exchange or relationship, but obtains pleasure by seizing the other’s image against its will. The goal is not only the sight of parts of the body that are concealed out of modesty or cultural opprobrium, but also to dismember the body of the other. The voyeur watches what is forbidden in order to destroy the physical integrity of the person by substituting a dismembered body for the unified image.

Several circumstances can lead to the occurrence of voyeurism. The instinct to see is used through dis-

avowal and fetish formation to deny castration. The fantasy of the phallic mother and the split of awareness of the lack of a penis leads to rage and need for revenge towards her. For Masud Khan, the pervert does not succeed in creating a transitional object when reacting against the encroachment of the maternal unconscious, but manages to fabricate an “internal collage-object,” which he then tries to discover in external reality. The voyeur engages in this type of theatricalization of the sexual relation by manipulation, submission, and humiliation of the object.

Robert Stoller has insisted on the cultural necessity of the perversion “forged by society and the family so that they are not harmed further” by instinctual cruelty. Because voyeurism turns the other into an image, an object of envy and covetousness, it appears to also bear witness to the visual focus of Western society. Seeing at any cost is an imperative that is often confused with science’s objective of mastery. In an “omniversal world,” according to Jacques Lacan’s expression, the voyeur becomes the one who does not allow himself to be blinded by sexual difference but cannot support the truth. He knows exactly what his mother is like, but tries to save his phallic image through some visual sleight-of-hand. More than anyone, he denies what he sees: the rift between the sexes, the fracture of bodies.

JEAN-MICHEL HIRT

*See also:* Activity/passivity; Exhibitionism; Face-to-face situation; Infantile sexual curiosity; “Instincts and Their Vicissitudes”; Libidinal development; Prohibition; Scopophilia/scopophilia; Turning around upon the subject’s own self; Visual.

### **Bibliography**

- Bonnet, Gérard. (1996). *La violence du voir*. Paris: Presses Universitaires de France.
- Freud, Sigmund. (1905d). Three essays on the theory of sexuality. *SE*, 7: 123–243.
- . (1915c). Instincts and their vicissitudes. *SE*, 14: 109–140.
- Khan, Masud. (1981). *Alienation in perversions*. London: Hogarth Press and the Institute of Psycho-Analysis.
- Stoller, Robert. (1975). *Perversion: The erotic form of hatred*. New York: Pantheon.





## WAELDER, ROBERT (1900–1967)

An Austrian psychoanalyst who taught in the psychiatric section of Philadelphia Jefferson Medical College, Robert Waelder was born on February 20, 1900, in Vienna, and died on September 28, 1967 in Broomall, Pennsylvania.

He was the son of Joseph Waelder, a Jewish merchant. After graduating from Maximilian *gymnasium* with honors in 1918, Waelder entered the university and in 1921 obtained a doctorate in physics.

At the age of twenty-two, Waelder consulted Sigmund Freud about treatment and, following his advice, he started a personal analysis with Robert Hans Joki; he subsequently underwent training analyses with Hermann Nunberg and Anna Freud. In 1924, Waelder became a member of the Vienna Psychoanalytic Society, where he performed a variety of functions as librarian and as a member of the candidate committee. From 1932 to 1939, with Ernst Kris, Waelder edited *Imago*, becoming that journal's editor-in-chief in 1934.

As a representative of the Viennese analysts, and within the context of an exchange of views, in 1936 Waelder presented in London his critique of the teachings of Melanie Klein; "The Problem of the Genesis of Psychical Conflict" was published in 1936. Waelder also presented to the Royal Institute of International Affairs his work on psychology and politics, which was published as "The Psychological Aspects of International Affairs" and suggested how psychoanalytic notions might be applied to the study of war; in a similar vein, he had written a short study on collective psychoses; this was published first in French, and subsequently as *Psychological Aspects of War and Peace*. Another socio-political work, *Progress and Revolution*,

was published in 1967. According to Richard Sterba, Waelder "showed a certain unworldliness that stood in contrast to the vastness of his scientific and literary knowledge" (Sterba, p. 138). He nevertheless created a considerable impression upon colleagues. "Waelder's extensive knowledge and his vast vision are easily seen, particularly in his later writings" (p. 141).

Waelder's first marriage was to Jenny Pollak, who in 1928 also became a member of the Vienna Psychoanalytic Society. In 1938, he emigrated to the United States and taught at the Boston Psychoanalytic Institute. Later, in 1943, he settled in Philadelphia and became a training analyst at the recently founded Philadelphia Psychoanalytic Institute. After a schism, in which members broke away to form the Philadelphia Association for Psychoanalysis, Waelder served as president of that organization from 1953 to 1955. In 1963, he was appointed professor of psychoanalysis at the psychiatry department of Jefferson Medical College in Philadelphia.

ELKE MÜHLEITNER

*See also:* United States

### **Bibliography**

- Sterba, Richard. (1982). *Reminiscences of a Viennese psychoanalyst*. Detroit: Wayne State University Press.
- Waelder, Robert. (1929). Psychological aspects of war and peace. *Geneva Studies*, 10, 2.
- . (1960). *Basic theory of psychoanalysis*. New York: International Universities Press.
- . (1967). *Progress and revolution; a study of the issues of our age*. New York: International Universities Press.



———. (1976). *Psychoanalysis: Observations, theory, application: Selected papers of Robert Waelder*. New York: International Universities Press.

## WAGNER-JAUREGG, JULIUS (JULIUS WAGNER RITTER VON JAUREGG) (1857–1940)

Julius Wagner Ritter von Jauregg, an Austrian professor of psychiatry, was born on March 7, 1857, in the city of Wels, in Upper Austria, and died in Vienna on September 27, 1940. He was the son of a high ranking civil servant. While still a student and like Freud, he published the results of his original research in the laboratory of Salomon Stricker, professor of experimental pathology at the University of Vienna. After obtaining his doctorate in medicine in 1880, Wagner-Jauregg, for two years, remained an assistant in Stricker's laboratory, where he met Freud. The two men became friends and colleagues. When he failed to be admitted to a training program in internal medicine, Wagner-Jauregg decided on psychiatry. He submitted his thesis for his habilitation in neuropathology in 1885 and qualified as a privatdozent in psychiatry in 1888. In 1889 he was appointed *professor extraordinarius* at the University of Graz. Four years later, in 1893, he was appointed *professor ordinarius*, or full professor, at the University of Vienna, where he also became director of the First Psychiatric and Neurological Clinic and, from 1902, of the Second Psychiatric Clinic.

The course of Wagner-Jauregg's scientific work includes such empirical discoveries as the central role of iodine deficiency in the etiology of cretinism and the introduction of iodine therapy to treat goiter. Most significant was his use of malarial inoculations to treat general paresis, then a relatively common disorder in patients suffering from tertiary syphilis. This treatment represented his belief that inducing febrile illness could prove therapeutic in cases of psychosis, and in 1927 it won him the Nobel Prize in physiology or medicine.

Wagner-Jauregg was accused of abusing soldier-patients in his clinic by employing extremely painful electrical treatments to treat shell shock. The 1920 debate protocols from the military commission investigating charges of brutality suffered by soldiers at the hands of army doctors during the First World War reveal a fundamental disagreement between Freud and

Wagner-Jauregg in their respective views on the nature of what came to be known as war neuroses. Freud was appointed as an expert in the case after other psychiatrists, former students of Wagner-Jauregg, recused themselves. In Wagner-Jauregg's view, as was commonly thought at the time, soldiers who seemed to be suffering from battle-related shell shock were actually malingerers. In contrast, Freud suggested the importance of the unconscious in such cases; he brought forward positive results of psychoanalytic treatment and proposed that war neuroses be treated more humanely and considered as purely psychological in nature. Freud emphasized that he believed Wagner-Jauregg could not be personally guilty of cruelty to patients.

Despite Wagner-Jauregg's negative attitude toward psychoanalysis, a number of analysts, including Helene Deutsch, Heinz Hartmann, Otto Pötzl, and Paul Schilder, all worked in his clinic as interns or assistants. Psychoanalytic training carried an obligation to work in a clinical setting in a university psychiatric department. Wagner-Jauregg's congratulations on the occasion of Freud's sixtieth birthday led to subsequent regular respectful exchanges between the two men.

EVA LAIBLE

See also: Freud, Anna; Hartmann, Heinz; Isakower, Otto; "Notes Upon a Case of Obsessional Neurosis" (Rat Man); Nunberg, Hermann; Pötzl, Otto; Schilder, Paul Ferdinand; War neurosis.

### Bibliography

- Brown, Edward M. (2000). Why Wagner-Jauregg won the Nobel Prize. *History of Psychiatry*, 11, 371–382.
- Eissler, Kurt R. (1986). *Freud as an expert witness: The discussion of war neuroses between Freud and Wagner-Jauregg* (Christine Trollope, Trans.). Madison, CT: International Universities Press. (Original work published 1979)
- Jones, Ernest. (1953–1957). *Sigmund Freud: Life and work* (3 vols.). New York: Basic.
- Lesky, Erna. (1976). *The Vienna medical school of the 19th century* (L. Williams and I. S. Levij, Trans.). Baltimore, MD: Johns Hopkins University Press. (Original work published 1965)
- Mühlleitner, Elke. (1992). *Biographisches Lexikon der Psychoanalyse: Die Mitglieder der psychologischen Mittwoch-Gesellschaft und der Wiener psychoanalytischen Vereinigung, 1902–1938*. Tübingen, Germany: Diskord.
- Whitrow, Magda. (1993). *Julius Wagner-Jauregg (1857–1940)*. London: Smith-Gordon.

## WALTER, BRUNO (1876–1962)

The celebrated conductor and composer Bruno Walter was born in Berlin on September 15, 1876, and died in Los Angeles on February 17, 1962.

Born German, Bruno Walter Schlesinger was naturalized as an Austrian citizen in 1911, took French citizenship in 1938, and became an American citizen in 1948. Dropping his surname in favor of “Walter” represented an identification with Walther von Stolzing, the hero of Wagner’s comic opera, *Die Meistersinger von Nürnberg*. Walter’s musical training took place in Berlin, Cologne, and Hamburg, where he met avant-garde composer Gustav Mahler, who became his mentor and whom he followed to Vienna. There he began a brilliant career as conductor and pianist, and was also Mahler’s staunch defender.

Walter was an active participant on the unique and complex intellectual scene in turn-of-the-century Vienna, and his introduction to psychoanalysis occurred in 1906, while a young conductor and Mahler’s protégé. Then at a crucial stage in life, he suffered from a paralyzing neuralgia and, after consulting a number of specialists, he decided to seek help from Freud. From Walter’s autobiography we know the course and outcome of their meeting, which has been the subject of a small number of studies. Freud’s work with Walter was unusual in that he operated less as psychoanalyst than as a psychiatric consultant.

Indeed, while the young Walter expected months of psychological investigation, Freud, after a physical exam and a single visit, prescribed sojourns in Italy and Sicily. The impact of the consultation had such an effect that Walter obeyed immediately. His subsequent treatment with Freud resembled therapy by suggestion such as was common in the nineteenth century. When Walter asked Freud if he would be able to play in front of an audience because he feared a relapse, Freud took upon himself the responsibility, assuming the role of a protective paternal figure and inducing an almost hypnotic effect upon Walter, traces of which were still discernable forty years later.

The case history of Bruno Walter was discovered by the Austrian analyst Richard Sterba, who also emigrated to the United States and was a great music lover. Since his 1951 publication, this unusual affair has come regularly under scrutiny, whether for purely historical value, as a key example of brief therapy, for Freud’s use of a somatic approach, or even as a method of treating the so-called “actual neuroses.”

The close-knit Viennese artistic milieu fostered fortuitous encounters. Mahler, for example, also had a therapeutic consultation with Freud; and Ernest Jones, in the second volume of Freud’s biography, mentions that it took place to the intervention of Viennese neurologist Richard Nepalpek, who also happened to be a relative of Mahler’s wife, Alma. Others have suggested Walter as the source of the consultation, but have not been able to prove it. It is true that during the 1930s Walter collaborated with Herbert Graf, better known in psychoanalytic circles as “Little Hans.” Whether these experiences intensified Walter’s powerful admiration for Freud, as revealed by Sterba, is not known.

NICOLAS GOUGOULIS

*See also:* Music and psychoanalysis; Suggestion.

### Bibliography

- Chesire, Neil M. (1997). The empire of the ear: Freud’s problem with music. *International Journal of Psycho-Analysis*, 6, 1127–1168.
- Garcia, Emanuel E. (1990). Somatic interpretation in a transference cure: Freud’s treatment of Bruno Walter. *International Review of Psycho-Analysis*, 17, 83–88.
- Gougoulis, Nicolas, and Kapsambélis, Vassilis. (1996). Recherches sur le concept freudien des névroses actuelles. *Topique*, 61, 493–502.
- Sterba, Richard F. (1951). A case of brief psychotherapy by Sigmund Freud. *International Journal of Psycho-Analysis*, 38, 75–80.
- Walter, Bruno. (1946). *Theme and variations. An autobiography*. New York: Alfred A. Knopf.

## WANT OF BEING/LACK OF BEING

For Jacques Lacan, human being is a “lack of being.” That was how he designated the subject’s fundamental emptiness as it was caused by the first symbolization and by the fact that desire originates in castration.

From the beginning of his teaching, Lacan noted that for Freud the object is fundamentally lost, and the subject spends his life looking for it. The object of psychoanalysis is the lack of an object, and this lacking object is at the heart of being. Lacan started elaborating on this notion of a lack of being in 1957, when he

set about describing the oedipal crisis in terms of the dialectic of desire and the question of the phallus.

During the mirror stage, the infant identifies with a certain point within the maternal space. In fact, what the subject takes for its own being is an other, both an image in the mirror and an alter ego. This fundamental alienation establishes misapprehension whereby one's being is confused with one's ego. From the beginning the subject is torn. He is divided between the place from which he sees himself, and the image, the other with which he identifies. From this perspective, a human being can never experience a wholeness that would amount to being.

Because language allows the child to symbolize the mother's alternating presence and absence, it makes it impossible for the child to become one with the mother. From this point on, a gap is introduced between the mother and child and any illusion of totality is broken. The subject experiences his lack of being, and when father later appears to put the phallus into play, he proves the lack of being of the maternal phallus. "[T]he child's desire manages to identify with the mother's want-to-be" (Lacan, 2002, p. 197). This desire begins as a quest for an object that might fill this lack.

Paradoxically the subject, as an effect of the symbolic (trapped within language), can only use language to search for the lost object. As Lacan wrote, "The being of language is the nonbeing of objects" (p. 253). Being is only a "lack of being," and the thing that could fill this lack is forbidden. This prohibition maintains desire. Thus desire appears as the metonymy of a lack of being whose signifier is the phallus that marks what the mother lacks. The subject's being is lack, and the cut that produced the symbolic is the object *a*, which is the real insofar as it is articulated in the symbolic and which is also a gap that the ego as image occupies. The image of the body, the principal mirage, indicates the place of desire insofar as it is desire for nothing. This is the relation of human beings with their own lack of being. But at the same time, the image is what prevents the human being from seeing it.

ALAIN VANIER

See also: Subject's castration; Symbolic, the (Lacan).

### Bibliography

Lacan, Jacques. (1958–1959). *Le Séminaire-Livre VI, Le désir et son interprétation* (unpublished seminar).

———. (1997). *The seminar of Jacques Lacan, Book VII, The ethics of psychoanalysis, (1959–1960)* (Dennis Porter, Trans.). New York: W. W. Norton, 1997.

———. (2002). *Écrits: A selection*. (Bruce Fink, Trans.). New York: W. W. Norton.

## WAR NEUROSI

Freud's interest, and that of his disciples, in war neurosis (*névrose de guerre*) developed during the First World War (1915b). The first psychoanalysts had an opportunity to observe and to monitor many patients presenting such distinctive symptoms as paralyses, tremors, recurring nightmares, the loss of sexual desire, and the like, all related to the experience of war. Observations and debate on these cases were presented in 1918 to the Fifth International Congress in Budapest, by Freud, Sándor Ferenczi, Karl Abraham, Ernst Simmel and Ernest Jones. As well as the scientific interest in these pathologies there was a need to prove to detractors of psychoanalysis (who were only too happy to see a picture of neurosis emerge that left, according to them, no room for the unconscious) that war neurosis had in effect a definite kinship with transference neuroses and hysteria.

The common denominator would be trauma, which acts by breaching the psychic apparatus, and which may appear either from the outside (traumatic neurosis) or even from the inside (transference neurosis) of the subject. In every case the trauma consists of too great a quantity of excitation, which ruptures the protective shield system, the psychic envelope. Generally the symptoms appear after a clear interval and take hold as a defense against anxiety.

From this period on, psychoanalysts have demonstrated that trauma acts as a precipitating factor, revealing a pre-existing neurotic structure; war then being the second instance or the "afterwardsness" of an infantile trauma. (*Afterwardsness* is Jean Laplanche's neologism to translate *après coup* and *Nachträglichkeit* into English. *Deferred action* is the term used frequently in the Standard Edition.) The symptoms (rumination over the traumatic event, recurring nightmares, insomnia) appear as repeated attempts to bind and abreact the trauma.

As the issue of the psychic after-effects of war is always unfortunately topical, these works are used as a benchmark for the teams who organize the treatment

of war victims in their countries, as the articles of Marie-Rose Moro testify. But furthermore there is a line of thought that results today in “Post Traumatic Stress Disorders,” and which breaks, unfortunately, with metapsychological topography and with the theory of afterwardsness.

ALAIN DE MIJOLLA

*See also:* Germany; Kardiner, Abram; Neurosis; Simmel, Ernst; Tavistock Clinic; Trauma; Traumatic neurosis.

### **Bibliography**

Ferenczi, Sándor. (1980). Two types of war neuroses. In *Further contributions to the theory and technique of psychoanalysis* (pp. 124–141; John Rickman, Ed.; Jane Isabel Suttie et al, Trans.). New York: Brunner/Mazel. (Original work published 1916/1917).

Ferenczi, Sándor, Abraham, Karl, Simmel, Ernst, and Jones, Ernest. (1921). *Psychoanalysis and the war neuroses* (The International Psychoanalytical Library, No. 2). London: International Psychoanalytical Press.

Freud, Sigmund. (1919d). Introduction to "Psycho-analysis and the war neuroses." *SE*, 17: 205–210.

Moro, Marie-Rose. (1998). L'enfant en situation de guerre ou de catastrophe, réflexion préliminaire et Soutien psychologique auprès des ex-détenus bosniaques musulmans et de leur famille, Médecins sans frontières. *Medical News*, 7, 2.

### **Further Reading**

Tucker, P., and Trautman, R. (2000). Understanding and treating PTSD: Past, present and future. *Bulletin of the Menninger Clinic*, 64, 37–51.

## **WASHINGTON PSYCHOANALYTIC SOCIETY**

The organizational history of psychoanalysis in the Washington D.C.-Baltimore metropolitan area is as convoluted and complex as the intellectual weave that created it. Psychoanalysis started early in Washington, embraced by key U.S. psychiatrists, and it mutated and expanded over the better part of a century. Currents of thought and practice, often in conflict, came to include ego psychology, Freudian revisionism, Sullivanian interpersonal theory, and the use of psychoanalytic theory to understand and treat psychoses. Among the important figures in its history must be counted

psychiatric pioneers Adolf Meyer and William Alanson White, the maverick Harry Stack Sullivan and his colleagues Frieda Fromm-Reichmann and Clara Thompson, and the determined Viennese defender of orthodoxy, Jenny Waelder-Hall.

The precursor to the Washington Psychoanalytic Society was founded in 1914, with William Alanson White as its chair. Like several other psychiatrists fascinated by Freudian ideas, White was superintendent of the Government Hospital for the Insane, soon to be renamed St. Elizabeth's Hospital. White, who had been interested in Freud's teachings since about 1909, became the first American author of a book on psychoanalysis when his *Mental Mechanisms* was published in 1911. Other significant figures early on the Washington scene included Adolf Meyer, who was associated with Johns Hopkins University, Ives Hendrick of Sheppard and Enoch Pratt Hospital, and John MacCurdy, one of the founders of the American Psychoanalytic Association. Interest in treating the psychoses was common to all these figures, and the use of analytic ideas for therapeutic ends with severe psychopathology became an enduring feature of psychoanalysis in Washington-Baltimore.

Members of the Washington Society originally met regularly and discussed papers. A hiatus at the end of the First World War lasted for several years, and for a time the organization changed its name to the Washington Psychopathological Society to distinguish itself from a competing society. By the late 1920s, however, distinguished analysts were visiting Washington from abroad and the society had attracted significant local psychiatric talent. Ernest Hadley, one of the first to open a private psychoanalytic practice in Washington, became a major administrative figure in the American Psychoanalytic Association (APA) over the next two decades.

Efforts to create a more formal group culminated with the founding of the Washington-Baltimore Psychoanalytic Society in 1930. From the beginning the institute situated itself as a constituent of the APA, to which it became accredited in 1932; it also subsequently affiliated with the International Psychoanalytical Association. Members soon created a training program, formally established as the Washington-Baltimore Psychoanalytic Institute in 1940. Lewis Hill directed the institute until 1949; he was succeeded by Ernest Hadley for five years thereafter, until the latter's death in 1954.

Background and education of members of the Washington-Baltimore society in its early years distin-

guished them in the broader context of the evolution of psychoanalysis in the United States. "From the beginning," wrote Donald L. Burnham (1978) in an early historical evaluation, "diversity of membership and of approaches was a feature of the psychoanalytic groups which formed in this region." He added, "This may have been partly because of their 'home-grown' quality. There was less leadership and dominance from analysts who had come originally from Vienna or Berlin" (p. 89). Analysts in Washington included Midwesterners, Roman Catholics, and children of rural America.

Harry Stack Sullivan, a representative American who had grown up in upstate New York, strongly affected the whole trajectory of psychoanalysis in Washington-Baltimore; in retrospect, his influence was as pervasive and crucial as it was controversial and divisive. Like Meyer and White, Sullivan came to psychoanalysis via the treatment of psychoses. Soon after establishing the Washington Psychoanalytic Institute, he went on, during the mid-1930s, to help found the William Alanson White Psychoanalytic (later changed to: Psychiatric) Foundation and Washington School of Psychiatry. Active and influential in psychoanalytic circles, Sullivan was also loudly not a conventional analyst and eventually he developed a systematic theory of development that emphasized the interpersonal determinants of psychological life and the cultural components of mental disorders.

Sullivan's predominance also expressed itself through the people he influenced in Washington and Baltimore, as well as those he antagonized. Clara Thompson was a friend, colleague, and ally who became a powerful figure in the Washington-Baltimore Psychoanalytic Society and helped establish and lead the William Alanson White Institute in New York, originally as a satellite of the Washington-Baltimore Institute. Frieda-Fromm Reichmann, who was also influenced by Sullivan, became prominent in treating severe mental illness with intensive psychotherapy, and was active in all the local organizations. On Sullivan's antagonistic side was Jenny Waelder-Hall, a Viennese-trained analyst who arrived in Washington in the mid-1940s. Considerable personal enmity grew up between her and Sullivan, said to be apparent from their first meeting. Donald Burnham (1978) suggested that "it is tempting to view Waelder-Hall and Sullivan not only as eloquent spokesmen but as literal personifications of Vienna orthodoxy and American eclecticism and of the difficulty, if not impossibility, of reconciling the two" (p. 102).

The permutations that occurred in Washington psychoanalysis soon after the end of World War II pro-

ceeded, in any event, along intellectual fault lines with the help of some personal and professional hostility. By 1946 the Washington-Baltimore Psychoanalytic Society split into two groups, although they would share a single training organizations until separate institutes were both officially approved in 1952 and fully accredited by the American Psychoanalytic Association three years later. The Baltimore Psychoanalytic Society represented a strong version of the European and Viennese current of orthodoxy led by Waelder-Hall; while the Washington Psychoanalytic Society, although it included orthodox analysts, also expressed Sullivan's influence, which was to outlast his premature death in 1949.

Using psychoanalysis to treat severe mental disorders followed a unique and separate but intertwined trajectory in Washington-Baltimore. Apart from the early work of Meyer and White, Sullivan, who declined to accept the therapeutic pessimism commonly seen in European psychiatry concerning psychosis, developed a treatment scheme for schizophrenia for which he claimed a high rate of success. By the late 1930s, Chestnut Lodge, a private sanatorium in Rockville, Maryland, became the site of efforts to treat patients with severe mental illness using psychodynamic principles. Invited by director Dexter Bullard, Frieda Fromm-Reichman became the first of a number of psychoanalysts to employ intensive, long-term therapy with schizophrenics at Chestnut Lodge.

Although tensions between orthodox analysis and dissident currents persisted through the 1950s and 1960s in Washington-Baltimore, the period saw steady growth in psychoanalysis at a time when the profession found support at the National Institute of Mental Health and a host of local institutions, including Walter Reed Hospital and Georgetown University Medical School. In the institutional skein, many prominent analysts held multiple appointments. When Fromm-Reichman's celebrated *Principles of Intensive Psychotherapy* was published in 1950, for example, she not only was a leader at Chestnut Lodge but taught at the Washington School of Psychiatry and the Washington-Baltimore Psychoanalytic Institute, as well as the William Alanson Institute of Psychiatry in New York.

By the 1970s, the decline of psychoanalysis as a medical specialty led to modifications in many programs that encouraged postgraduates outside of medicine, and those in Washington and Baltimore were not exceptions. The Washington Psychoanalytic Institute

expanded its theoretical base, and training has come to embrace a diversity of viewpoints in addition to a Freudian core, including object-relations theory, self psychology, intersubjectivist, and constructivist approaches. The Baltimore Psychoanalytic Institute, founded by Jenny Waelder-Hall on classical lines, was now the Baltimore-Washington Psychoanalytic Institute, and relocated to Laurel, Maryland. It modified its programs beginning in the 1960s, and now trains psychologists and social workers as well as psychiatrists.

Other institutes also opened in the Washington-Baltimore metropolitan area in the last two decades of the twentieth century. The International Institute of Object Relations therapy, founded by David E. Scharff and Jill Savage Scharff, is based in Chevy Chase, Maryland, although it has created training modules in nearly a dozen other cities. The Institute of Contemporary Psychotherapy and Psychoanalysis of Washington, founded by Joseph Lichtenberg and Rosemary Segalla, bases its training program on Heinz Kohut's self psychology.

JOHN GALBRAITH SIMMONS

### **Bibliography**

- Burnham, Donald. (1978). Orthodoxy and eclecticism in American psychoanalysis: The Washington-Baltimore experience. In J. Quen and E. Carlson (Eds.), *American psychoanalysis: origins and development* (pp. 87–108). New York: Brunner Mazel.
- Noble, Douglas, and Burnham, Donald. (1969). *History of the Washington Psychoanalytic Society and the Washington Psychoanalytic Institute*. Washington DC: Washington Psychoanalytic Society.

## **WEANING**

Weaning is the name for the suppression or reduction of breast milk and/or baby formula to replace it with more solid food. Weaning is at the crossroads of biology, culture, and the psychic organization of the mother/child dyad.

Weaning involves the interactive process of interruption of the corporeal relationship between mother and child. It begins spontaneously during the second six months of life as an effect of the infant's maturation; the infant manifests a decreased interest in feeding, especially if it has been breast fed, and begins an active search

for autonomy that the mother can perceive and facilitate according to her affective syntony with the infant, as Benjamin Spock described in "The Striving for Autonomy and Regressive Object Relationship" (1963), according to her affective syntony with the infant.

In his *Introductory Lectures on Psycho-Analysis* (1916–1917a [1915–1917]), Sigmund Freud described weaning as traumatic, perhaps owing to syntony, but also as the moment when nostalgia for the mother appears, which is present in all infants, and above all in those who have not been breast fed. Melanie Klein studied the relations between weaning and the depressive position that accompanies it and that continues on thereafter. In "Les complexes familiaux dans la formation de l'individu" (Family complexes in the formation of the individual; 1938), Jacques Lacan organized the various points of view in the following way: Traumatic or not, he explained, weaning leaves in the psyche a permanent trace of the biological relationship it interrupts. This moment also presents the twofold aspect of a crisis in the psyche, the first that unquestionably has a dialectical structure. For the first time, a vital tension is expressed in terms of a mental intention.

Weaning forms the basis for the positive aspect of the weaning complex, that is, the image of nourishment that tends to establish the most archaic and stable feelings uniting the individual with his or her family: It thus constitutes the basis of familial and social life.

In *L'Image inconsciente du corps* (The unconscious image of the body; 1984), Françoise Dolto discussed weaning as an oral castration of the child, that is, an imposed deprivation of what for him or her is cannibalism in relation to the mother. Dolto also elaborated E. Forman's concept of motherhood as a developmental stage and associated the possibility of successful weaning with the mother's ability to accept the interruption of body-to-body contact, and above all, to communicate with the infant in various ways, among them providing food, but also by means of words and gestures, which represent the desire and possibility to speak for the child: "The baby is talking about feeding, but not about the breast."

The time of weaning, ever earlier in our culture, represents the relational conflict characteristic of the late oral or oral-sadistic stage. Bernard Golse emphasized its ambivalent aspect, due to the fact that incorporating the mother becomes destructive with teething. The infant who suckles the breast attacks it and wins nourishment

by inflicting hurt. The cannibalistic impulses of the two partners are reciprocally activated, and both must learn to sense and control aggression. This is indeed what happens in cases of “good” weaning, due both to a simultaneous establishing of distance by the mother and by the infant and to the working out of the child’s aggressive and libidinal requirements in the presence of the mother as an object.

Failures in weaning include late weaning (often because of the mother’s desire to prolong the erotogenic pleasure of nursing), which can be experienced by the infant as punishment and which makes the process of separation/individuation difficult. Inversely, premature weaning—that is, before the infant has been able to invest other objects—has varying effects according to the circumstances. Among the most serious failures, there is fusion of the life instinct and the death instinct, as in cases of mental anorexia or addictions to orally ingested substances. In extreme cases of weaning following abandonment, Dolto explained in *Les Étapes majeures de l’enfance* (The major stages of childhood; 1994), a behavioral regression, due to residual fantasies from before the trauma, compromises the previously acquired sound-producing capability of the larynx and the oral cavity. Psychogenic mutism can ensue, with or without loss of hearing.

James S. Grotstein studied the end of analytic treatment as a weaning that makes possible a liberation of narcissism with the aim of accepting the world as it is. Paul-Claude Racamier more specifically described weaning from the sleeping treatment, during which patients are lavished with maternal care that helps them to emerge from the regression and to establish very deep bonds with the physician providing treatment.

GRAZIA MARIA FAVA VIZZIELLO

See also: Anaclisis/anaclitic; Breastfeeding; Cruelty; Imago; Maternal; Oral eroticism; Psychosexual development; *Psychoanalyse et Pédiatrie* (Psychoanalysis and pediatrics); Technique with children, psychoanalytic; Sexuality.

### **Bibliography**

- Dolto, Françoise. (1984). *L’Image consciente du corps*. Paris: Le Seuil.
- . (1994). *Les Étapes majeures de l’enfance*. Paris: Gallimard.
- Lacan, Jacques. (1984). Les complexes familiaux dans la formation de l’individu (pp. 23–30; written for *Encyclopédie*

*française*, Vol. 8). Paris: Larousse. (Original work published 1938)

- Spock, Benjamin. (1963). The striving for autonomy and regressive object relationship. *Psychoanalytic Study of the Child*, 18, 361–36.

### **Further Reading**

- Furman, Erna. (1982). Mothers have to be there to be left. *Psychoanalytic Study of the Child*, 37, 15–28.
- Mahler, Margaret, Pine, Fred, and Bergman, Anni. (1975). *The psychological birth of the human infant: Symbiosis and individuation*. New York: Basic Books.
- Pine, Fred. (1994). The era of separation-individuation. *Psychoanalytic Inquiry*, 14, 4–24.

---

## **WEININGER, OTTO (1880–1903)**

Otto Weininger, an Austrian and Jewish intellectual, was born on April 3, 1880, in Vienna, where he committed suicide on October 4, 1903. Adelheid, Otto’s mother, whose health was frail, was a submissive wife to his father, Leopold, a renowned goldsmith and powerful personality. Of his six brothers and sisters, only four reached adulthood. A gifted student, Otto entered the University of Vienna in 1898 and took courses in all the various subjects he would later treat in his *Sex and Character* (1906). His professors included Friedrich Jodl, Ernst Mach, and Richard von Krafft-Ebing. He also frequently attended gatherings of the university philosophical society. In 1900 he traveled to Paris with Hermann Swoboda to attend a conference on psychology, where he sided with those in favor of an introspective approach to psychology as opposed to an experimental and biological approach.

Weininger began writing *Sex and Character* (originally entitled *Eros and Psyche*) in the autumn of 1900, and the book progressed through an exchange of ideas with Swoboda. In 1901, after having registered the copyright to his manuscript, he sought to publish it, and with this in mind he showed an outline to Freud, who was not favorably impressed. In 1902 Weininger submitted a revised version of the book to obtain his doctorate in philosophy. On the day he received his degree, he converted to Christianity. A third version of his book—with the added chapters “Judaism,” “Women and Mankind,” and “Woman and Her Significance in the Universe”—was published in June 1903 by the major publishing firm Braumüller.

Weininger suffered from severe mood swings of exaltation and depression. During the summer of 1902, he traveled in Northern Europe and, writing to his friend Arthur Gerber, asked, “Am I anything?” Weininger left for Italy in somber spirits. In Calabria on August 21, 1903, he drafted a new will and testament that replaced the one he had written the previous February 13. Returning home depressed, he spent five days at his parents’ home. On October 3 he shot himself through the heart in a rented room in the house in which Beethoven, his favorite musician, had died.

Weininger was buried in a Protestant cemetery; his father wrote the text for his gravestone. Leopold Weininger admired his son’s book and firmly defended Otto’s memory after his death, though Leopold did confide information about Otto to a psychiatrist, who betrayed his trust.

In 1904, texts collected by Weininger’s friend Moritz Rappaport were published as *Über die letzten Dinge* (translated as *On Last Things* [2001]). There Weininger’s suicide was explained as a logical conclusion to *Sex and Character* to insure its success both with a large general audience and among intellectuals. In 1906 Wilhelm Fliess’s charge of double plagiarism, specifically, that Freud had passed on Fliess’s original ideas about bisexuality to Weininger and Swoboda, also fueled the book’s notoriety. In the case of “Little Hans” (Herbert Graf), Freud wrote, “Weininger was completely under the sway of his infantile complexes; and from that standpoint what is common to Jews and women is their relation to the castration complex” (1909b, p. 36n). In his book, Weininger bears witness to the confusion about sexuality and science that was characteristic of the time.

ERIK PORGE

*See also: Christians and Jews: A Psychoanalytical Study; Fliess, Wilhelm; Self-hatred; Swoboda, Hermann.*

### **Bibliography**

- Freud, Sigmund. (1909b). Analysis of a phobia in a five-year-old boy. *SE*, 10: 1–149.
- Le Rider, Jacques. (1982). *Le cas Otto Weininger: Racines de l’antiféminisme et de l’antisémitisme*. Paris: Presses Universitaires de France.
- Porge, Erik. (1994). *Vol d’idées?* Paris: Denoël.
- Rodlauer, Hannelore. (1990). *Otto Weininger: Eros und Psyche*. Vienna: Verlag der Österreichischen Akademie der Wissenschaften.

Sengoopta, Chandak. (2000). *Otto Weininger: Sex, science, and self in imperial Vienna*. Chicago: University of Chicago Press.

Swoboda, Hermann. (1911). *Otto Weininger Tod*. Vienna: F. Deuticke.

Weininger, Otto. (1906). *Sex and character*. New York: G. P. Putnam’s Sons. (Original work published 1903)

———. (2001). *A translation of Weininger’s “Über die letzten Dinge, 1904–1907,” On last things*. Lewiston, NY: Edwin Mellen Press. (Original work published 1904)

---

## **WEISS, EDOARDO (1889–1970)**

Edoardo Weiss, a physician and psychoanalyst, was born in Trieste (then a part of Austria-Hungary), on September 21, 1889, and died in Chicago on December 14, 1970. He spent his childhood and adolescence in Trieste, part of a stable, well-to-do Jewish family originally from Bohemia. After studying German in high school, he enrolled in 1908 in medical school in Vienna. In October of that year, he visited Freud, whose essay on the *Gradiva* he had previously read. Weiss suffered from a slight case of agoraphobia and wanted to talk to Freud about his desire to practice psychoanalysis. Freud sent him to see Paul Federn, with whom he began therapy, which lasted until 1911. Weiss, the first president of the Italian Psychoanalytic Society and a member of the Vienna Psychoanalytic Society in 1913, was the real founder of the psychoanalytic movement in Italy.

In 1914 he joined the Austro-Hungarian army as a physician. He was initially assigned to Lublin, Poland, then sent to the Croatian front. It was in Lublin, in a hospital train, that he met his friend and fellow student, Viktor Tausk, whose depression from the war and declining relations with Freud had affected him deeply.

In 1917 Weiss married Wanda Shrenger. Weiss met his wife at the University of Vienna; she would become the first woman admitted to the Italian Psychoanalytic Society. In 1919 he returned to Trieste, then a part of Italy, to work as a psychiatrist in a provincial hospital. He also opened his own practice as a psychoanalyst, introducing the field to men such as Italo Svevo and Umberto Saba—in other words, the leading representatives of Italian literature.

In 1927 he was forced to resign from the psychiatric hospital where he worked, due to his failure to join the Fascist party and Italianize his name. He moved to Rome, where he published *Elementi di psicoanalisi* (1931). In



1932 he re-established the Società Psicoanalitica Italiana and launched the review, *Rivista italiana di psicoanalisi*.

In 1932 Emilio Servadio, who had trained with Weiss and who was interested in parapsychology, organized several sessions with a medium in order to demonstrate the existence of paranormal phenomena. Weiss informed Freud of his conviction in the authenticity of the phenomena he had witnessed firsthand and received the following response: "Given your role as a pioneer of psychoanalysis in Italy, it would be unfavorable to consider you at the same time a pioneer of occultism."

In 1935 Weiss managed to obtain official recognition from the International Psychoanalytical Association (IPA) for the small Italian psychoanalytical society and, with his students Nicola Perrotti and Emilio Servadio, attended the International Congresses in Wiesbaden (1932), Lucerne (1934), and Marienbad (1936).

Having emigrated to the United States in 1939, he joined the Menger Clinic in Topeka, Kansas, in 1940, then moved to Chicago, where, together with Franz Alexander, he became interested in the application of psychoanalysis to psychosomatics. In 1942 he became a training analyst at the Chicago Institute of Psychoanalysis. In 1950 he took on the responsibility of collecting the writings of Paul Federn in order to promote an awareness of phenomenological ego psychology, which in his opinion had been misunderstood by Freud.

In his last years Weiss taught at Marquette College in Milwaukee as a guest lecturer for a couple of years, while he was consistently a training analyst at Chicago for many years, until his retirement. In 1970 his correspondence with Freud was published under the title *Sigmund Freud as Consultant*.

His writings include *Agoraphobia, isterismo d'angoscia* (1936), *Principles of Psychodynamics* (1950), *The Structure and Dynamics of the Human Mind* (1960), *Agoraphobia in the Light of Ego Psychology* (1964), and some seventy articles. It was Weiss who introduced the term *destrudo* to express the death instinct, and the concepts of *projective identification* (created by Weiss in 1925, before Melanie Klein and with a slightly different meaning), *psychic presence*, *resonance*, and *ego transition*, which were critical for understanding the nature and modality of object relations. Weiss was especially interested in agoraphobia, our understanding of which he considerably deepened in several articles and two monographs.

ANNA MARIA ACCERBONI

See also: Claustrophobia; Death instinct (Thanatos); *Ego Psychology and Psychosis*; *Elementi di psicoanalisi*, Libido; Italy; *Rivista di psicoanalisi*.

### Bibliography

- Accerboni, Anna Maria. (1988). *Psychoanalyse et fascisme: deux approches incompatibles. Le rôle difficile d'Edoardo Weiss. Revue internationale d'histoire de la psychanalyse, 1*, 225–243.
- . (1990). Sigmund Freud as remembered by Edoardo Weiss, the Italian pioneer of psychoanalysis. *International Review of Psycho-Analysis, 17* (3), 351–359.
- Federn, E. (1982). Edoardo Weiss und der Beginn der psychoanalytischen Ichpsychologie. *Sigmund Freud House Bulletin, 6* (1), 25–32.
- Freud, Sigmund, and Weiss, Edoardo. (1970). *Sigmund Freud as a consultant: Recollections of a pioneer in psychoanalysis*. New Brunswick, NJ: Transaction Publishers.
- Roazen, Paul. (2004). *Edoardo Weiss: The house that Freud built*. New Brunswick, NJ: Transaction Publishers.
- Weiss, Edoardo (1964). *Agoraphobia in the light of ego psychology*. New York: Grune & Stratton.

---

## WELTANSCHAUUNG

The term *Weltanschauung*, literally, "view of the world," had a very specific meaning for Freud, who defined it in the New Introductory Lecture as follows: "A *Weltanschauung* is an intellectual construction which solves all the problems of our existence uniformly on the basis of one overriding hypothesis, which, accordingly, leaves no question unanswered and in which everything that interests us finds its fixed place" (1933a [1932], p. 158).

Indeed Freud had already used this concept as a stick with which to beat philosophies and religions—both lambasted, for example, in his *Future of an Illusion* (1927c). In 1933, however, he broadened the notion, bringing science too under its aegis; this with the proviso, though, that "the *Weltanschauung* of science already departs noticeably from our definition. It is true that it too assumes the uniformity of the explanation of the universe; but it does so only as a programme, the fulfillment of which is relegated to the future." (pp. 158–159). The fact was that the notion of *Weltanschauung* usefully supplemented that of culture,

for it helped specify culture’s different spheres and point up their underlying emotional *raison d’être*.

Freud extolled and defended the virtues of an intolerance that refused, in the name of “truth,” to consider all domains of human intellectual activity to be of equal value: “It is simply a fact that the truth cannot be tolerant, that it admits of no compromises or limitations, that research regards every sphere of human activity as belonging to it and that it must be relentlessly critical if any other power tries to take over any part of it” (p. 160). It has to be said, therefore, that Freud’s views on religion and especially on philosophy were rather narrow—judging, as he did, that they were totally closed to doubt. On the other hand, his opposition to dogmatism is much easier to comprehend if one bears in mind that dogmatism constitutes the major temptation for any theoretician, and no doubt for Freud himself with respect to psychoanalysis. And it was certainly for the sake of psychoanalysis that he defended the ideal of scientific asceticism.

Apropos of the religious *Weltanschauung*, in 1933 Freud articulated ideas he had expressed in *Totem and Taboo* (1912–13a) on the formation of religions, while restating, in essence, some themes of *The Future of an Illusion* concerning the way religion panders to humanity’s “desire for knowledge” and to its infantile need for protection. To emphasize how risky a religious view of the world is to thought, which it limits through its interdictions, he also revisited the ideas expressed in “Civilized Sexual Morality and Modern Nervous Illness” (1908d). Most of Freud’s observations on the notion of *Weltanschauung* were in fact concerned with religion, but he did also mention art, which for him was “almost always harmless and beneficent; it does not seek to be anything but an illusion” (1933a [1932], p. 160), and philosophy, about which he wrote: “Philosophy is not opposed to science, it behaves like a science and works in part by the same methods; it departs from it, however, by clinging to the illusion of being able to present a picture of the universe which is without gaps and is coherent” (p. 160).

Another kind of *Weltanschauung*, about which Freud usually had very little to say, save for his considerations on war, was politics, and specifically Marxism, to which he opposed a conception of the evolution of societies that was just as materialist as Marx’s, but without any real discussion of Marx’s theories, which seemed to him to be derived from “the obscure Hegelian philosophy, in whose school Marx graduated” (p. 177). Nihilism of the anarchist variety he denounced

as pure sophistry; it nevertheless constituted an attack on the very core of scientific ideals, since it abolished the criterion of truth.

Finally, Freud’s reflections on the notion of *Weltanschauung* were generally conflated with an earnest and vibrant pleading of the case of science, as when he said about the common man: “Truth seems to him no more capable of comparative degrees than death” (p. 172). His conclusion was a real rallying cry: “A *Weltanschauung* erected upon science has, apart from its emphasis on the real external world, mainly negative traits, such as submission to the truth and rejection of illusions. Any of our fellow-men who is dissatisfied with this state of things, who calls for more than this for his momentary consolation, may look for it where he can find it. We shall not grudge it him, we cannot help him, but nor can we on his account think differently” (p. 182).

SOPHIE DE MIJOLLA-MELLOR

*See also:* Ideology; Illusion; Linguistics and psychoanalysis; *New Introductory Lectures on Psycho-Analysis*; Psychoanalytic research; Science and psychoanalysis; Truth.

### Bibliography

- Freud, Sigmund. (1908d). “Civilized” sexual morality and modern nervous illness. *SE*, 9: 177–204.
- . (1912–13a). Totem and taboo. *SE*, 13.
- . (1927c). The future of an illusion. *SE*, 21: 1–56.
- . (1933a [1932]). New introductory lectures on psycho-analysis. *SE*, 22: 1–182.

---

### “WHY WAR?”

In 1931 the Permanent Committee on Literature and the Arts of the League of Nations proposed exchanges of letters between intellectuals. Contacted in June 1932, Freud agreed to respond to Einstein’s letter, which he received in August. The result was a “Letter to Albert Einstein” titled “Why War?” On September 8, 1932, he stated to Max Eitingon that he had finally finished writing the “tedious and sterile so-called discussion with Einstein” (quoted in Jones, 1957, Vol. 3, p. 185). To Einstein’s question “Is there any way of delivering mankind from the menace of war?” (1933b [1932], p. 199), Freud would respond by returning to a number of issues that he had already addressed in his work on this subject,

from “Thoughts for the Times on War and Death” (1915b) to *Civilization and Its Discontents* (1930a). Instead of his correspondent’s proposal to consider the relationship between right and might, he preferred to consider the relationship between right and violence, and he argued that as distinct from the primitive law of the strongest, “right is the might of a community” (p. 205). But right itself cannot be exercised without violence. The wish to prevent war was no doubt embodied in the League of Nations, but that organization remained impotent, except on the level of ideas.

According to Freud, Einstein was correct in positing an instinct of hate in humankind, a notion that fit with “our mythological theory of the instincts” (p. 212). “The death instinct turns into the destructive instinct when, with the help of special organs, it is directed outwards on to objects. The organism preserves its own life, so to say, by destroying an extraneous one” (p. 211). This was a factual circumstance that had to be taken into account; the Bolshevist utopia clearly pointed up the illusion of egalitarian material satisfaction.

Freud acknowledged that he did not have much to propose: “We are pacifists because we are obliged to be for organic reasons” (p. 214). “We are shaped by the long process of the development of civilization, to which we owe the best of what we have become, as well as a good part of what we suffer from. Though its causes and beginnings are obscure and its outcome uncertain, some of its characteristics are easy to perceive. It may perhaps be leading to the extinction of the human race, for in more than one way it impairs the sexual function; uncultivated races and backward strata of the population are already multiplying more rapidly than highly cultivated ones. The process is perhaps comparable to the domestication of certain species of animals and it is undoubtedly accompanied by physical alterations; but we are still unfamiliar with the notion that the evolution of civilization is an organic process of this kind” (p. 214).

“How long shall we have to wait before the rest of mankind become pacifists too? There is no telling. . . . But one thing we can say: whatever fosters the growth of civilization works at the same time against war” (p. 215).

In the spring of 1932, William C. Bullitt presented Freud with the manuscript of their jointly authored “psychological study” of President Thomas Woodrow Wilson (1966). This study was in line with the hope that Freud expressed in the last pages of his letter to Einstein: “One instance of the innate and ineradicable

inequality of men is their tendency to fall into the two classes of leaders and followers. The latter constitute the vast majority; they stand in need of an authority which will make decisions for them and to which they for the most part offer an unqualified submission. This suggests that more care should be taken than hitherto to educate an upper stratum of men with independent minds, not open to intimidation and eager in the pursuit of truth, whose business it would be to give direction to the dependent masses. It goes without saying that the encroachments made by the executive power of the State and the prohibition laid by the Church upon freedom of thought are far from propitious for the production of a class of this kind. The ideal condition of things would of course be a community of men who had subordinated their instinctual life to the dictatorship of reason. Nothing else could unite men so completely and so tenaciously, even if there were no emotional ties between them. But in all probability that is a Utopian expectation” (1933b, p. 212–213). In London in 1948 it was suggested that political leaders be systematically required to undergo psychoanalysis. This naturally elicited particularly acute reactions among psychiatrists who were members of the French Communist Party.

Written in that summer of 1932, on the threshold of the rise of Nazism and the deployment of the death instinct that would result from it, Freud’s reflections later became a premonition whose accuracy he could not possibly have imagined.

ALAIN DE MIJOLLA

*See also:* Civilization (*Kultur*); Death instinct (Thanatos); Mythology and psychoanalysis; “Thoughts for the Times on War and Death.”

### Source Citation

Freud, Sigmund. (1933b [1932]). “Warum Krieg? (Brief an Albert Einstein [sept. 1932]), Warum Krieg? Pourquoi la guerre? Why War? Paris: Internationales Institut für gestige Zusammenarbeit am Völkerbund (Institute for International Cooperation); *GW*, 16: 13–27; Why war? *SE*, 22: 197–215.

### Bibliography

Freud, Sigmund. (1915b). Thoughts for the times on war and death. *SE*, 14: 273–300.

———. (1930a [1929]). Civilization and its discontents. *SE*, 21: 57–145.

Freud, Sigmund, and Bullitt, William. (1966b [1938]). Introduction. In their *Thomas Woodrow Wilson, twenty-eighth president of the United States: A psychological study* (pp. xi–xvi). New York: Weidenfeld and Nicholson.

Jones, Ernest. (1957). *Sigmund Freud: Life and work*. London: Hogarth.

## WIENER PSYCHOANALITISCHE VEREINIGUNG

The history of the Wiener Psychoanalytische Vereinigung (Vienna Psychoanalytical Society) is the primal history of psychoanalysis. The members of the Psychological Wednesday Society commenced their meetings in Freud's apartment in 1902. In 1908 the group adopted the designation "Vienna Psychoanalytical Society" and was registered under this name as a local group of the newly formed International Psychoanalytical Association in Vienna. Most of the members of the Vienna Psychoanalytical Society were of Jewish origin and shared the history of the Jews in the twentieth century.

The Society's first president was Alfred Adler, who resigned in 1911, after which Sigmund Freud himself took over the helm until 1938. The founding period was of course characterized by the genius of Freud, who built the Society's fortunes not only through his theories but also by his skills as an organizer. Sándor Ferenczi described this as the time of heroism and guerrilla war. Adler and others resigned at the end of 1911 and formed the Society for Free Psychoanalytic Research, later known as the Society for Individual Psychology. Practically all activities of the Vienna Psychoanalytical Society ceased during the First World War because, as Freud put it, the voice of psychoanalysis could not make itself heard above the thundering of cannon. When the war was over, the society quickly resumed operations. As regards its organization, two groups of members can be distinguished: representatives of the society's "heroic phase" like Paul, Otto Rank, and Eduard Hitschmann; and the second-generation analysts, most of whom had already undergone formalized training, such as Anna Freud, Helene and Felix Deutsch, Edward and Grete Bibring, Wilhelm Hoffer, Wilhelm Reich, Richard Sterba, Otto Fenichel, and Siegfried Bernfeld.

When this new generation of psychoanalysts took over, training was institutionalized and a psychoanalytic outpatient clinic was established. The foundation of the clinic in 1922 was followed two years later by that of the

training institute. The clinic was headed by Eduard Hitschmann, with Wilhelm Reich as his deputy. In May 1936, after many peripatetic years, the Vienna Psychoanalytical Society finally acquired premises of its own at Berggasse 7, where the society itself, the training institute, the outpatient clinic and the Internationaler Psychoanalytischer Verlag (the publishing house) were accommodated. The head of the training institute was Helene Deutsch, who already complained in her report for 1932 that the number of Austrian candidates had dropped sharply owing to the economic crisis. In the summer semester of that year the Vienna Psychoanalytical Society had 22 candidates, of whom 12 were American, 2 German and 8 Viennese. After Hitler's coming to power in 1933, significant numbers of candidates from Germany found a place for themselves at the training institute of the Vienna society.

After falling ill with cancer, Sigmund Freud was no longer able to take part in the society's scientific meetings. Its affairs were managed by Paul Federn, who was elected deputy president after Otto Rank's departure in 1925, and later by Anna Freud, who was elected second deputy and spoke for her father on the executive. A powerful influence on the affairs of the society was exerted by its "expanded executive," which met on Wednesday evenings at the Berggasse premises.

The imposition of an authoritarian constitution in Austria in 1934 and Hitler's coming to power in Germany did not present an immediate threat to the Vienna society. Although many members of the Society sympathized with the then banned Social Democrats, few—among them Siegfried Bernfeld, Otto Fenichel, Hermann Nunberg, Buchsbaum, Wilhelm Reich, and Friedjung—were politically engaged. However, "administrative measures" were adopted to prevent politically "dangerous" activity in the illegal left-wing groups by members and candidates.

The Vienna Psychoanalytical Society's heyday was in the late 1920s and the 1930s. Some of the seminal works of ego psychology originated at this time—for example, August Aichhorn's *Wayward Youth* (1925), Heinz Hartmann's *Die Grundlagen der Psychoanalyse* (Fundamentals of psychoanalysis; 1927), Anna Freud's *Introduction to Psycho-Analysis for Teachers* (1930) and later *The Ego and the Mechanisms of Defence* (1936), or Hermann Nunberg's *Principles of Psychoanalysis* (1932), which was based on lectures at the society. Whereas Vienna already had a rival in the thriving Berlin Psychoanalytic Institute in the 1920s, many Jewish psychoanalysts came to

Vienna or to the society's branch in Prague after the Nazis took power in 1933.

Max Schur (1972) noted in his memoirs that Hitler had made an overwhelming impression on the Austrian people and that many of those in Schur's group were convinced that the country would be unable to withstand the rising tide of Nazism. The first wave of emigration commenced in these years, those who left including Helene and Felix Deutsch, Siegfried Bernfeld, Ludwig Jekels, Wilhelm Reich, Hanns Sachs and Fritz Wittels. However, the endurance of Freud and his comrades who stayed behind was unrewarded. Freud's view that the Austrian people were not quite so brutal, expressed in a letter to Arnold Zweig, proved to be false. The Wehrmacht marched into Vienna on March 12, 1938, and the Vienna Psychoanalytical Society's executive held its last meeting on March 13. It was resolved that everyone who could should flee the country and that the seat of the society should be transferred to wherever Freud settled. The 68 extraordinary and ordinary members of the Vienna Psychoanalytical Society, as well as an estimated 36 candidates, had to leave Vienna; only Alfred von Winterstein and August Aichhorn stayed put.

Freud himself was able to depart with his family on June 4, 1938. At the 15th International Psychoanalytical Congress in Paris, Ernest Jones said in his opening address that it was breathtaking to think that, of all cities in the world, it was precisely in Vienna that psychoanalysis was no longer to be practiced.

From 1938 August Aichhorn gathered a small circle about him. He noted in his "Gedenkschrift" [commemorative review]: "Starting with training analyses and continuing with regular seminars and courses and with the study of the works of the Freud school, the group strove to attain its goal. One of our friends, Count Karl von Motesicky, who had contributed much to the foundation of the group, died in a concentration camp. . . . Without formalities and difficulties, but exercising caution towards the outside world, the group worked on throughout the period in a genuine spirit of loyalty and friendship." From 1938 until 1945, Vienna was a branch of the "German Reich Institute of Psychological Research and Psychotherapy"; it was headed temporarily by Aichhorn, who was replaced by Gebattel in 1943.

After 1945, The Vienna Psychoanalytical Society was spared the fate of the German Psychoanalytical Society and the arduous birth pangs of the German Psychoanalytical Association; it was eventually reopened by Aichhorn,

who wrote: "Now our path is clear; everyone can follow his own research inclinations without hindrance, and everyone is indeed doing so." Nor was it long before IPA recognition was forthcoming. However, it took decades for the Vienna Psychoanalytical Society to re-establish its links with international psychoanalysis. In setting about the task of reconstruction, it was pervaded by the melancholy realization that, while it had to preserve Freud's legacy, it could no longer aspire to the intellectual greatness and influence of the old society. This was the prevailing atmosphere for many years. After the trauma of the expulsion and annihilation of the Jews and the ensuing destruction of psychoanalysis in Vienna, a cloak of silence descended over the unspeakable.

Upon Aichhorn's death in 1949, Winterstein succeeded to the presidency and remained in office until 1957.

In 1950 the Society had just one candidate in training, and the mood emerges clearly from a letter written by Winterstein to Glover: "The only tendency which I have observed in the last few years, and which I have been enjoining the members to follow since I became president, is to immerse themselves in the study of Freud's writings and to explore new ideas with great caution."

Except for the interregnum of A. Becker (1972–74), Wilhelm Solms-Rödelheim and Harald Leupold-Löwenthal occupied the presidency from 1957 until 1982. Solms was one of the founders of the "Mitteleuropäische Arbeitstagung" (Central European Working Conference), which links the German-speaking psychoanalysts to this day, and also played an important part in the formation of the EPF. The International Psychoanalytical Congress held in Vienna in the summer of 1971 renewed the society's ties with international psychoanalysis. The society began to grow again. After fierce argument over the incorporation of group psychoanalysis and the status of child analysis, a new generation of officers took the helm in 1982. Impelled by the candidates and younger members, a period of intense debate about the Vienna Psychoanalytical Society's past commenced. Although the older members were politically relatively untainted after the war, their mentality had been molded by it, and the society effectively continued its subterranean existence.

Peter Schuster became president in 1982 and was succeeded in 1984 by Wolfgang Berner, whose period of office was distinguished by the rapprochement with contemporary psychoanalysis and the holding of the EPF congress in 1993. The society's president from

1993 until 1998 was Wilhelm Burian. A central concern of the organization since the 1980s has been the permanent reorganization of training so as to bring it into line with international standards. An indication of the laboriousness of this process is the fact that the third revision of the training regulations is as of 2005 being discussed. Unfortunately psychoanalysis has remained substantially a Viennese phenomenon for the Austrian public; debate is largely confined to the Vienna Psychoanalytical Society, the Vienna Arbeitskreis für Psychoanalyse (Psychoanalytic study group) and the Freud-Gesellschaft. Like many psychoanalytic organizations, however, the Vienna Psychoanalytical Society has been increasingly preoccupied with itself and has shown relatively little orientation towards the outside world. Around the start of the twenty-first century public relations functions have been assumed with great professionalism by the Sigmund-Freud-Gesellschaft and the Freud Museum.

After prolonged peregrinations, the Vienna society moved into its new headquarters at Gonzagagasse 11 in 1986. By 2005, it had over 70 members and some 100 candidates, thus for the first time exceeding the membership level of 1938. Its work in the 1980s centered on anti-Semitism both within and outside analyses and the working through of the society's wartime and post-war past. Other themes have included the relations between psychoanalysis and psychoanalytic psychotherapy—a debate that culminated in the incorporation of a seminar on psychoanalytic psychotherapy in the training syllabus. In the fields of theory and clinical practice there have been many, sometimes violent, arguments about the future direction of psychoanalysis and the influence of other psychoanalytic schools, such as the “modern Kleinians” and object-relations theory as opposed to classical drive theory. The latter prevailed the late 1990s and still has a not inconsiderable number of adherents. Meanwhile, however, the society had also become an official professional organization, oscillating between the isolation of “toeing the line” and “traitorous participation” in the state bodies for psychotherapists. In 1989 the general assembly of the Vienna Psychoanalytical Society resolved by one vote to join the “Dachverband für Psychotherapie” (Confederation of psychotherapy) and later the Psychotherapiebeirat (Psychotherapy advisory committee). Then, in 1993, the Vienna Psychoanalytical Society became the first training organization to obtain recognition under the provisions of the Psychotherapy Law. The political work on the committees

and vis-à-vis the public has, in truth, not aroused much interest. However, if one were to compile an interim report, it would state that, although the Vienna Psychoanalytical Society is no longer the “hub” around which the other societies revolve, as it was before 1938, it has after a long period of hesitation shrugged off its self-imposed isolation and thereby regained its place in international psychoanalysis.

WILHELM BURIAN

*See also:* Austria; Lehrinstitut der Wiener psychoanalytischen Vereinigung; *Minutes of the Vienna Psychoanalytic Society.*

### Bibliography

- Berner, Wolfgang. (1992). The Viennese Psychoanalytic Society after 1945, In Peter Kutter (Ed.). *Psychoanalysis International*, 1. Europe. Stuttgart-Bad Cannstadt: Frommann-Holzboog.
- Huber, Wolfgang. (1977). *Psychoanalyse in Österreich seit 1933*. Vienna-Salzburg: Geyer-Edition.
- Mühlleitner, Elke. (1992). *Biographisches Lexikon der Psychoanalyse (Die Mitglieder der Psychoanalytischen Mittwoch-Gesellschaft und der Wiener Psychoanalytische Vereinigung 1902–1938)*. Tübingen: Diskord.
- Schur, Max. (1972). *Sigmund Freud: Living and dying*. New York: International Universities Press.
- Solms-Rödelheim, Wilhelm. (1976). Psychoanalyse in Österreich. In D. Eicke (Ed.), *Tiefenpsychologie*. Beltz-Weinheim-Basle: Die psychoanalytische Bewegung.

---

### WILBUR, GEORGE B. (1887–1976)

George B. Wilbur was the second editor of *American Imago*, following the death of its founder Hanns Sachs, and Wilbur maintained that editorial position from 1947 until 1963. Wilbur was born in Larned, Kansas, on December 22, 1887, and died on Cape Cod in Hyannis, Massachusetts, on April 4, 1976.

Wilbur had first gone as an analytic patient to Otto Rank in New York City in the fall of 1926, at a time when Rank was over on one of his early trips to the United States. At the time there was little publicity about Rank's problems with Freud; Rank's *The Trauma of Birth* (1923) was originally dedicated to Freud, and analytic pupils abroad then thought the book had Freud's

blessings. Wilbur also went to Paris in the spring of 1927 to conclude the analysis with Rank; Wilbur’s wife Joy also went to Rank then for treatment. The Wilburs had put a mortgage on their house to finance the trip to Paris, which cost three or four thousand dollars, with one thousand going to Rank.

When Sachs died early in 1947, he had become a respected Boston analyst who also taught at Harvard Medical School, and Wilbur at that time went through all Sachs’s papers. By then Wilbur was an established early member of the Boston Psychoanalytic Society, although he practiced on Cape Cod. Sachs and Rank had been the original Viennese co-founders of *Imago* in 1912, but their intimate friendship did not survive the problems that arose between Freud and Rank. Wilbur insisted that there were no bitter feelings between Sachs and Rank, but that all the bitterness was in Jones’s biographical works.

Wilbur himself stayed in close contact with both Sachs and Rank; for a time, when the American Psychoanalytic Association (APA) was first considering making the Boston Psychoanalytic Society a branch affiliate, Wilbur’s association with Rank meant that he had to resign temporarily in the early 1930s from his membership in the Boston group, on the understanding that he would be reinstated after the APA’s acceptance of the Boston group had been secured. By 1936 Wilbur was once again a Boston analyst in good standing, although still living in South Dennis. Wilbur became a great expert on the details connected with the intellectual differences between Freud and Rank. Although Wilbur had been stigmatized within psychoanalysis for going to Rank in a year of the worst “vintage,” Wilbur maintained that he had never heard anything at all in his own analysis with Rank about the concept of the birth trauma.

Wilbur remained modest and unassuming, although he had graduated from Harvard College (1912) as well as Harvard Medical School (1916) before practicing as a psychiatrist. Wilbur was originally from Kansas, and heard about Freud first from his teacher, the psychologist E. B. Holt, at Harvard. Holt, like his own mentor William James, had been part of the Boston School of psychotherapy that preceded the coming of the Freudians. For a time Wilbur had practiced analysis in Iowa, until he first moved to South Dennis on Cape Cod in 1923. He preferred seeing patients a couple of times a week, and therefore felt himself more a Rankian than a Freudian, in that he became more interested in therapeutic improvements than in strict analysis. Wilbur, known among his

friends as “Jake,” appears in the American poet Conrad Aiken’s *Ushant* as “Jacob.”

PAUL ROAZEN

*See also:* Rank (Rosenfeld), Otto.

### **Bibliography**

- Lieberman, E. James. (1979). The Rank-Wilbur correspondence. *Journal of the Otto Rank Association*, 14 (1), 7–24.
- Roazen, Paul. (2003). Interview on Freud and Jung with Henry A. Murray in 1965. *The Journal of Analytical Psychology*, 48, 1–27.
- Slochower, Harry, and Schupper, Fabian X. (1967). George Wilbur at 80. *American Imago*, 24(4), 287–289.
- Wilbur, George B. (1943) Isador H. Coriat: Obituary. *Psychoanalytic Review*, 30, 479–83.
- Wilbur, George (Ed.). (1951). *Psychoanalysis and culture*. New York: International Universities Press.

---

### **“‘WILD’ PSYCHO-ANALYSIS”**

In a letter to Ferenczi dated October 27, 1910, Freud described this short text as a “little didactic paper” (vol. 1, p. 229). In “‘Wild’ Psycho-Analysis,” Freud described a consultation with a divorced woman who had come to him complaining of the crude advice given to her by her regular doctor, who, invoking the authority of psychoanalysis, had told her that she could remedy her anxiety only by returning to her husband, taking a lover, or masturbating.

Freud used this example to make several points. First, he stressed that, contrary to the claims of some of its detractors, psychoanalysis took “sexuality” to mean more than just sexual relations, and he preferred to use the word in a broader sense equivalent to that the verb “to love.” Second, he reasserted the sound basis for distinguishing the “actual neuroses” from those neuroses for which psychoanalysis was indicated, and he recalled that the analyst’s task is not just to explain the psychic causes of their conditions to patients, but also, and more importantly, to weaken the resistances that prevented them from discovering those causes for themselves. Psychoanalysis required an extended contact and the establishment of a transference relationship, without which the sudden revelation of secrets is “technically objectionable” (p. 226), even if on occasion the outcome is more

positive than that achieved by means of a pseudo-scientific explanation. In this connection, Freud evoked the notion of tact, which would later become the subject of an article by Ferenczi (1955).

Finally, because Freud's case involved a doctor who had not been psychoanalytically trained, he was able to point out that psychoanalytic technique could not be "learnt from books" but had to be "learnt from those who are already proficient in it" (p. 226). He also took this opportunity to announce the creation, in March 1910 at the Second Psycho-Analytical Congress in Nuremberg, of "an International Psycho-Analytical Association, to which its members declare their adherence by the publication of their names."

Freud would return to the necessity of psychoanalytic training in *The Question of Lay Analysis* (1926e), where he observed that "doctors form a large contingent of quacks in psychoanalysis" (p. 230).

ALAIN DE MIJOLLA

*See also:* Abstinence/rule of abstinence; American Psychoanalytic Association; Berliner Psychoanalytisches Institut; Groddeck, Georg Walther; International Psychoanalytical Association; Sexuality; Tact.

#### Source Citation

Freud, Sigmund. (1910k). "Über "wilde" Psychoanalyse," *Zentralblatt für Psychoanalyse*, 1, 91–95; *GW*, 7: 118–125; 'Wild' psycho-analysis. *SE*, 11: 219–227.

#### Bibliography

Ferenczi, Sándor. (1955). The elasticity of psycho-analytic technique. In his *Final contributions to the problems and methods of psycho-analysis* (pp. 87–101). London: Hogarth and the Institute of Psycho-Analysis. (Original work published 1928)

Freud, Sigmund. (1926e). The question of lay analysis. *SE*, 20: 177–250.

Freud, Sigmund, and Ferenczi, Sándor. (1993–2000). *The Correspondence of Sigmund Freud and Sándor Ferenczi* (3 vols.; Peter T. Hoffer, Trans.). Cambridge, MA: Harvard University Press.

### WINNICOTT, DONALD WOODS (1896–1971)

Donald Woods Winnicott, British psychoanalyst and pediatrician, was born in Plymouth, England, on

April 7, 1896, and died in London on January 25, 1971. He was the youngest child and only son of a prosperous provincial English merchant. He attended boarding school, where he read Darwin, and studied at the University of Cambridge, where he read Freud as an undergraduate. He entered the navy in 1917. In the First World War, while still a medical student, he both lost friends and saw action on a destroyer in the navy. Winnicott qualified as a physician in 1920. He gained membership in the Royal College of Physicians in 1922 and became a pediatrician.

From 1923 to 1924 he specialized in pediatrics, married, and began his training analysis with James Strachey. Later he had further analysis with Joan Riviere, and became a Kleinian training analyst. He became an associate member of the British Psycho-Analytical Society in 1934, a child analyst in 1935, a full member in 1936, and a training analyst in 1940. However, in the 1941–1945 controversial discussions in the British society between the adherents of Melanie Klein's views and the adherents of Anna Freud's, Winnicott played little part, finding himself unable to ally fully with either side. At that time, his interest in the effect of environmental factors on development made his ideas unacceptable to Klein. During the German blitz of the Second World War, he became a consultant to the Government Evacuation Scheme for London children. This work stimulated his thinking on the relationship between separation, deprivation, and delinquency, and it also introduced him to Clare Britton, a social worker who later became his second wife and lifelong colleague.

In 1944 Winnicott was elected fellow of the Royal College of Physicians. After the war he became director of the Child Department of the London Clinic of Psycho-Analysis and twice served as president of the British Psycho-Analytical Society (1956–1959 and 1965–1968). He lectured and broadcast on infant and maternal welfare, and inaugurated public lectures on psychoanalysis. He became active internationally, writing copiously for many audiences. While not joining any group in the British society, his thinking influenced members of the Middle Group, later the Independents. Winnicott died in his sleep after surviving several heart attacks.

Winnicott's work was informed by his vast experience in observing mothers and babies as a pediatrician, which allowed him to develop his ideas about the early experience of individuation and about ways of assessing psychic development, such as his spatula game and the Squiggle Game, for communicating with older



children. He described the psychophysiological state of a new mother as the “primary maternal preoccupation.” In contrast to Melanie Klein and Donald Fairbairn, who saw the infant as having a definable ego from birth, he saw the young infant as being undifferentiated from the mother, cryptically stating “There is no such thing as a baby,” meaning that a baby cannot exist alone, that there needs to be a mother or mothering person too. Close maternal attunement and repeated bodily care (the “facilitating environment”) allows the baby to begin to become aware simultaneously of its own separateness and that of its mother. Gradual and progressive failure of attunement at a rate at which the baby can increasingly tolerate (“good-enough mothering”) strengthens the emerging ego. The baby thus emerges from “absolute dependence” to “relative dependence” and begins to adapt to reality and the painful awareness of the mother’s separateness and all that this entails. Such adaptation includes the development of concern and capacity for guilt.

As the difference between the baby’s awareness of “me” and “not me” strengthens, many babies need a way of bridging a gap that might be too much for them. Such bridging explains the existence of transitional phenomena. The transitional space in which such phenomena occur provides room for the baby to develop play and an increasing ability to stand being alone. The baby becomes disturbed when lacking a “good-enough” environment, for instance, when a mother is physically or emotionally absent, disturbed, or intrusive, or when the baby has needs that cannot be fulfilled. When the mother cannot respond sensitively to the baby’s gestures but substitutes one of her own, her baby cannot be spontaneous, only compliant, even imitative—thus developing a “false self.”

Winnicott also wrote about the effect of mother’s unconscious states, including her unconscious hatred of her baby, and he linked such hatred with the hate that those responsible for delinquents develop toward their charges and the idea of hate in the countertransference. This developmental framework, with its implication that pathology is linked to environmental failure (either deficient provision for needs or impingement), allowed Winnicott to see that regression in analysis may be a search for the absent experiences, and it led him to emphasize that the analytic setting and the person of the analyst may stimulate the patient’s own inborn maturational tendency toward growth and individuation to bring about self-cure.

Strongly influenced by Klein, Winnicott accepted much of her thinking, particularly with regard to the internal world and its objects, and fantasy. He differed from her on the effect of environmental provision and emphasized the importance of early real relationships.

Together with Klein and Fairbairn, one of the founders of the British object-relations school, Winnicott extended his influence to social work, education, developmental psychology, and the probation service, in addition to pediatrics and psychoanalysis. His writing has been translated into almost all European languages; he has been published in the United States, South America, and Japan, and there is strong interest in his work in France and Italy. In Britain, the Independent Group of the British Psycho-Analytical Society has followed his work, and his ideas have interested those working in the field of infant observation in Great Britain and the United States, as well as those adhering to self-psychology theory and practice.

Since his death, the Winnicott Trust, founded by his widow Clare, has continued and completed publication of his work, and funds raised have supported research in early mother-infant relationships at the Winnicott Research Unit at the University of Cambridge. The Squiggle Foundation, an organization devoted to the study of Winnicott’s thinking, holds an annual program of lectures and courses in London.

JENNIFER JOHNS

*Notions developed:* Breakdown; Capacity to be alone; False self; Good-enough mother; Handling; Holding; Integration; Primitive agony; Self (true/false); Squiggle; Transitional object; Transitional object, space; Transitional phenomena.

*See also:* Abandonment; Addiction; Adolescence; Alcoholism; Annihilation anxieties; Autism; Breastfeeding; Bulimia; Childhood; Children’s play; Collective unconscious (analytical psychology); Creativity; Cruelty; Demand; Dependence; Deprivation; *Empty Fortress, The*; *Envy and Gratitude*; Family; Framework of the psychoanalytic treatment; Great Britain; Illusion; *Infans*; Infant development; Infantile omnipotence; Infantile psychosis; Infant observation (direct); Internal object; Intersubjective/intrasubjective; Jokes; Lack of differentiation; Lie; Look/gaze; Maternal; Maternal care; Maturation; Mirror stage; Mutual analysis; Narcissism; Object; Object *a*; Omnipotence of thoughts; Partial drive; Splitting; Postnatal/postpartum depression; Primary identification;

Primary object; Psychosomatic limit/boundary; Protective shield; Puberty; Quasi-independence/transitional stage; Reality testing; Regression; Reverie; Self-image; Self, the; Suffering; Symbiosis/symbiotic relation; Symbolization, process of; Technique with children, psychoanalytic; Transference hatred.

### **Bibliography**

- Phillips, Adam. (1988). *Winnicott*. London: Fontana Press.
- Rodman, F. Robert. (2003). *Winnicott: Life and work*. Cambridge, MA: Perseus Publishing.
- Winnicott, Donald. (1958). *Collected papers: Through paediatrics to psycho-analysis*. London: Tavistock Publications.
- . (1964). *The child, the family, and the outside world*. London: Penguin Books.
- . (1965). *The maturational processes and individual development*. London: Hogarth Press and the Institute of Psycho-Analysis.
- . (1971). *Playing and reality*. London: Tavistock Publications.

---

## **WINTERNITZ-FREUD, PAULINE REGINE (PAULI)**. See Freud, Sigmund (siblings)

---

## **WINTERSTEIN, ALFRED FREIHERR VON (1885–1958)**

Austrian psychoanalyst Alfred Freiherr von Winterstein was born on September 25, 1885, in Vienna, where he died on April 28, 1958.

Educated at the famous Theresianische Akademie and the Franz Josefs-Gymnasium, Winterstein obtained his *Matura* (or baccalaureate) in 1903. He completed his law studies in 1905.

After reading *The Interpretation of Dreams* (1900a), Winterstein contacted Freud, attended his lectures, and in 1910 became a member of the Vienna Psychoanalytic Society. At that time he was writing articles for the *Neue Freie Presse*, a bourgeois liberal newspaper, and publishing poems in Karl Kraus's *Die Fackel*. He also wrote plays and was member of the Pen Club.

Winterstein submitted his thesis in 1911 and worked for a time under the famous experimental psychologist Wilhelm Wundt at the University of Leipzig. During a visit to Burghölzli, while staying with Eugen Bleuler, he began an analysis with Carl Jung.

During the First World War, Winterstein was in the dragoons and, after four years of duty, was promoted to cavalry captain. Returning to Vienna, he continued an analysis with Eduard Hitschmann and began practicing analysis himself. He was interested in the application of analytic ideas to literature and especially in the psychoanalysis of parapsychological phenomena.

After the Nazi Anschluss, Winterstein elected to remain in Vienna, but because by the Nuremberg laws he was not considered a “pure Aryan,” he was forbidden to practice psychotherapy; this was also the case with August Aichhorn, the only other member of the Vienna Psychoanalytic Society who remained in the city during the war.

Winterstein employed the war years to write a book on Adalbert Stifter, the great Austrian writer, poet, and painter. His *Adalbert Stifter, Persönlichkeit und Werk: eine tiefenpsychologische Studie* was published in 1946.

After 1945, Winterstein played a role in reconstituting the Vienna Psychoanalytic Society, serving as its president from 1949. He enjoyed an international reputation and was invited in 1953 and 1955 to lecture at meetings of International Psychoanalytical Association. In 1957, poor health led to his retirement.

HARALD LEUPOLD-LÖWENTHAL

See also: Austria; Wiener psychoanalytische Vereinigung.

### **Bibliography**

- Winterstein, Alfred F. (1911). Drei Fälle von Versprechen. *Internationale Zeitschrift für Psychoanalyse*, 2, 292–293.
- . (1920). Die Nausikaeepisode in der Odyssee. *Imago*, 6, 349–383.
- . (1928). Die Pubertätstriben der Mädchen und ihre Spuren im Märchen: eine psychoanalytische Studie. *Imago*, 14, 199–274.
- . (1934). Contributions to the problem of humor. *Psychoanalytic Quarterly*, 3, 303–316.
- . (1946). *Adalbert Stifter, Persönlichkeit und Werk: eine psychoanalytische Studie*. Vienna: Phönix.
- . (1949). *Telepathie und Hellsehen im Lichte der modernen Forschung und wissenschaftlichen Kritik*. Vienna: Phönix.

———. (1954). A typical dream-sensation and its meaning. *International Journal of Psycho-Analysis*, 35, 229–233.

———. (1956). On the oral basis of a case of male homosexuality. *International Journal of Psycho-Analysis*, 37, 298–302.

## WISH FOR A BABY

The wish for a baby is one of the fantasies of childhood, part of the set of significant motifs transmitted to the child unbeknownst to its parents along with the biological “breath of life” (Bydlowski, 1978), and that evolves in conjunction with individual libidinal development. It is marked by the Oedipus complex, by kinship relationships, by family experiences of death and mourning. In Freud’s account, the woman’s “wish to possess a penis is normally transformed into a wish for a baby” (1933a [1932], p. 101). The wish for a baby is superimposed, repressed, or revived in different forms at different times of life.

From the oral stage, the wish for a baby inherits the urge to destroy the mother’s body entirely, including her belly and everything in it. From the anal stage—inclined to control and revenge—comes the theme of the stolen baby, used to try and compensate for the loneliness of the child confronted by the parental couple. Both the little girl and the little boy long for the power, at once marvelous and uncanny, to have a child: an imaginary child, manipulable at first anally, then mentally (Soulé, 1982). The boy must in due course renounce this wish, whether by means of displacement or sublimation, of repression, or of reaction-formations ranging from the ritual of *couvade* to the disavowal of paternity, or even beyond, to delusion and paranoia (Soulé, 1982).

The wish for a child is also relevant to narcissism. An ideal child, issuing from an ideal mother, is the equivalent of the penis for the mother whom it fulfils. With no third person to come between mother and baby, there is no corresponding denial of the anal, aggressive function of the imaginary child. On the oedipal level, for the girl, the child is a product of incest, obtained from the father without the mother’s knowledge and in rivalry with her.

Maria Torok (1968) relates the wish for a child in its narcissistic dimension to death and mourning: “The wish for a child can be understood as a denial of the loss of a part of oneself.”

CHRISTINE PETIT

*See also:* Pregnancy, fantasy of; Female sexuality; Penis envy.

## Bibliography

Bydlowski, Monique. (1978). Les Enfants du désir, le désir d’enfant dans sa relation à l’Inconscient. *Psychanalyse à Université*, 4 (13), 59–92.

David, Didier. (1996). Le désir d’enfant." In D. David and S. Gosme-Sèguret (Eds.). *Le Diagnostic prénatal*. Paris: E.S.F.

Freud, Sigmund. (1933a [1932]). New introductory lectures on psycho-analysis. *SE*, 22: 1–182.

Soulé, Michel. (1982). L’enfant imaginaire: Fantasma d’enfant, le désir d’enfant, le désir de grossesse. In *La Dynamique du nourrisson*. Paris: E.S.F.

Torok, Maria. (1968). Maladie du deuil et fantasme du cadavre exquis. *Revue française psychanalyse*, 32 (4).

## WISH-FULFILLMENT

In Freudian theory, the fulfillment of a wish is an aspiration, theme, or, one might even say, motor principle, of unconscious formations like dreams, hysterical symptoms, and fantasies. In these formations an unconscious, infantile sexual wish is expressed and fulfilled in imagination in a more or less disguised way. From this point of view, the fulfillment in question is neither total nor definitive, but unique and dynamic.

Freud set forth his theory of wish fulfillment in chapter 3 of *The Interpretation of Dreams* (1900a), though he had already mentioned the idea in the preceding chapter, “The Method of Interpreting Dreams,” in connection with his dream of Irma’s injection: “The dream represented a particular state of affairs as I should have wished them to be. Thus its content was the fulfilment of a wish and its motive was a wish. When the work of interpretation has been completed, we perceive that a dream is the fulfilment of a wish” (1900a, pp. 118–119, 121). In fact, four months before his dream of injecting Irma, in his correspondence with Wilhelm Fliess, Freud first alluded to the general principle of the dream as wish fulfillment. The context was in the account of the “dream of convenience” of “Mr. Pepi” (Rudi Kaufmann, a nephew of Josef Breuer), who dreamed he was in the hospital so as not to have to wake up in the morning (Letter of March 4, 1895, p. 114).

Only interpretation and analysis can penetrate the disguise under which a wish-fulfillment is expressed. An unconscious wish is fulfilled in an imaginary way and appears to the dreamer in masked form. Dream work transforms the latent content of the dream into manifest content by means of the processes of condensation and displacement. Wish fulfillment is not the cause of the dream, but it shapes the intentional structure of the dream. Hence the need for the work of interpretation. To be fulfilled, the wish, as an instinctual intrapsychic force, must effect what Freud, in *The Interpretation of Dreams* (1900a), called “perceptual identity” (pp. 566–567). The path followed leads from the triggering of an internal need to its satisfaction in the experience of a hallucinated wish-fulfillment.

Thirty years later, in *New Introductory Lectures on Psycho-Analysis* (1933a [1932]), Freud reaffirmed that “in every dream an instinctual wish has to be represented as fulfilled. The shutting-off of mental life from reality at night and the regression to primitive mechanisms which this makes possible enable this wished-for instinctual satisfaction to be experienced in a hallucinatory manner” (pp. 18–19).

His study of traumatic dreams connected with accident neuroses led Freud, in *Beyond the Pleasure Principle* (1920g), to postulate aims of the dream other than the fulfillment of an unconscious wish. On the face of it, a dreamer whose dreams regularly culminated in anxiety could not be striving to satisfy an unconscious wish, yet even “if you want to take these latter objections into account, you can say nevertheless that a dream is an *attempt* at the fulfillment of a wish,” Freud wrote (1933a [1932], p. 29). With respect to hysterical symptoms, Freud noted that an unconscious, infantile wish was certainly being fulfilled, but so was a preconscious wish, so that two opposing wishes, issuing from two different mental agencies, were being fulfilled. As for fantasies or daydreams, “like dreams, they are wish-fulfillments. . . . The wishful purpose that is at work in their production has mixed up the material of which they are built, has rearranged it and has formed it into a new whole” (Freud, 1900a, p. 492).

A wish never arises in isolation; it always encounters other wishes, opposing it in an open structure, so that desire is always in the process of organizing meaning. Jacques Lacan considered this always-incomplete destiny of desire to be the basis of the dialectic between demand and desire, which for him defined the human condition.

DELPHINE SCHILTON

*See also:* Amentia; Anxiety dream; Convenience, dream of; Dream screen; Experience of satisfaction; Fantasy; Formations of the unconscious; Illusion; *Interpretation of Dreams, The*; Nightmare; Reverie; Transgression; Wish, hallucinatory satisfaction of a; Work (as a psychoanalytical notion).

### Bibliography

- Freud, Sigmund. (1900a). The interpretation of dreams. *SE*, 4: 1–338; 5: 339–625.
- . (1920g). Beyond the pleasure principle. *SE*, 18: 1–64.
- . (1933a [1932]). New introductory lectures on psycho-analysis. *SE*, 22: 1–182.
- Lacan, Jacques. (1998). *Le séminaire*. Book 5: *Les formations de l'inconscient*. Paris: Seuil.

---

## WISH, HALLUCINATORY SATISFACTION OF A

The notion of the *hallucinatory satisfaction of a wish* is one of the key elements in the Freudian conception of psychic functioning. It postulates that, under certain conditions, there is an intense need, transformed into a wish for an object from which satisfaction is expected, which, under certain circumstances can produce sensations that are attributed wrongly to an external agent, yet present all the characteristics of reality. This is *hallucinatory satisfaction*.

These certain conditions can be of four kinds: the immaturity of the psyche of the newborn baby, dreams, problems in psychic functioning in certain neurotics, or certain psychoses, called, as a matter of fact, delusional.

Concerning the first kind, Freud expressed, from the time of his *Project for a Scientific Psychology* (1950a [1895]), a hypothesis that must be placed among the founding ones of psychoanalysis. What are the possible outlets, he asked, for the “need that has been excited” in the child? The child has no means of autonomous satisfaction at its disposal, so that “the primal powerlessness of the human being becomes *the earliest source of all moral notions*” (in other words: of the entire psychic life, insofar as it is pointed toward the wish—the italics are Freud’s). An “experience of satisfaction” can ensue, because of an intervening adult who creates an

association between the two “mnemonic images,” that of need (or wish) and that of satisfaction. The reappearance of the former can, when the need (wish) is intense, reactivate this association: “Now, when the state of *urgency* or *wishing* reappears, the cathexis will also pass over on to the two memories and will activate them. . . . I do not doubt that in the first instance this wishful activation will produce the same thing as a perception, namely a *hallucination*” (1950c, p. 319), Freud adding forthwith: “If reflex action is thereupon introduced, disappointment cannot fail to occur.”

This idea was taken up again a few years later in *The Interpretation of Dreams*: “The first wishing seems to have been a hallucinatory cathecting of the memory of a satisfaction. Such hallucinations, however, if they were not to be maintained to the point of exhaustion, proved to be inadequate to bring about the cessation of the need or, accordingly, the pleasure attaching to satisfaction” (1900a, p. 598).

As Freud wrote, in 1911, in a text called “Formulations on the Two Principles of Mental Functioning”: “The state of psychical rest was originally disturbed by the peremptory demands of internal needs. When this happened, whatever was thought of (wished for) was simply presented in a hallucinatory manner, just as still happens to-day with our dream-thoughts every night. It was only the non-occurrence of the expected satisfaction, the disappointment experienced, that led to the abandonment of this attempt at satisfaction by means of hallucination.” At this point the *reality principle* is introduced, supplanting the *pleasure principle*. Freud answered a possible objection in a note at the bottom of the page: a being totally under the sway of the pleasure principle could not survive “for the shortest time,” responding, in fact: “the infant—provided one includes with it the care it receives from its mother—does almost realize a psychical system of this kind. It probably hallucinates the fulfillment of its internal needs” (1911b, pp. 219–220). This “provided one includes with it the care it receives from its mother” was well remembered by a number of later authors, especially Donald Winnicott.

The notion returned in “A Metapsychological Supplement to the Theory of Dreams” (1916–17f, p. 231): “At the beginning of our mental life we did in fact hallucinate the satisfying object when we felt the need for it. But in such a situation satisfaction did not occur, and this failure must very soon have moved us to create some contrivance with the help of which it was possible to distinguish such wishful perceptions from a real fulfillment

and to avoid them for the future. In other words, we gave up hallucinatory satisfaction of our wishes at a very early period and set up a kind of ‘reality-testing.’”

There is a certain hesitancy in these texts of Freud between the terms *need* and *wish*; and only in his later work did Freud come to distinguish them more clearly, need being defined as the expression of an organic function (hunger, sexual and so forth), wish as something mental when this need is transformed into the wish to have an object. Accordingly, the status of the drive, as a “border concept” (between psyche and soma) is put into question (cf., among others, Laplanche, 1987).

As a matter of fact, in all his writings Freud insisted on the “disappointment” following “inevitably” on hallucinatory satisfaction (a hallucination of milk supplies no nourishment . . .). Accordingly, a reality principle is set up at the same time representation is born, pointing to what is “here inside,” not, as in the case of perception, to what is “also outside” (1925h).

This notion was utilized by Freud, in very similar terms, in his theory about dreams (1900a): the dream is, in effect, a realization of a wish. In the framework of psychic functioning, cut off from perception and motor functions, “excitation follows a retrograde way.” There is a “topographical regression,” and a restitution of “the identity of perception,” or an association between the “images” of the movement of desire and its satisfaction; but also regression to a primitive functioning as “the dream is a fragment of infantile psychic life.” If the pleasure principle prevails momentarily over the reality principle, this sort of satisfaction is quite liable to take on a hallucinatory quality.

At the same time as he was forming these theories, Freud was also approximating dream functioning to the function of psycho-neurotic defense mechanisms, in particular those of hysteria: certain hysterical symptoms, especially those affecting perception, can be explained by an analogous schema.

Psychoses lend themselves particularly well to the hallucinatory satisfaction of wishes, and, moreover, in a waking state: “In psychoses these ancient and repressed modes of psychic work return in force,” as the analysis of the Schreber case (Freud, 1911c) showed dramatically.

Sándor Ferenczi (1913) took up the schema of Freud and used it to account for the omnipotence of thought, such as is observable in the young child (“stage of hallucinatory magical omnipotence,” char-

acteristic of infantile megalomania), but also of obsessional structures.

Foremost among later authors who were interested in this question is Donald Winnicott (1971), who gave a further nuance to the idea by introducing the notions of *illusion* and *transitional space*, and also by describing the process of progressive re-autonomization of the mother (beyond the “primal maternal madness,” prolonged temporarily by the symbiosis of pregnancy). He saw in this the condition for the advent of disappointments, which in the Freudian model were both inevitable and necessary: the mother became “very good,” but would be also “very bad.” Winnicott wrote that a “perfect” mother, that is to say, one who immediately satisfied all her child’s needs, “could be nothing but a hallucination.” Denise Braunschweig and Michel Fain (1975) developed an analogous idea in a different theoretical context, opposing the “day mother” to the “night mother.”

In this respect, the studies of André Green (1993) should be mentioned; he did significant work on “negativity,” on the basis of a case of negative hallucination (where a perception is banished from existence). Equally the work of César and Sára Botella are relevant, centering on the concept of the “hallucinatory,” the term being taken as a substantive, as a description of a vast processual set.

ROGER PERRON

*See also:* Amentia; Convenience, dream of; Experience of satisfaction; *Interpretation of Dreams, The*; Wish/yearning; Wish-fulfillment; Word-presentation.

### **Bibliography**

Botella, César, and Botella, Sára. (1990). La Problematique de la régression formelle de la pensée et de l'hallucinoire. In *La Psychanalyse: Question pour demain, colloque de la S.P.P.* Paris: Unesco, Presses Universitaires de France.

Ferenczi, Sándor. (1913). Le développement du sens de la réalité et ses stades. In *Psychanalyse I, Oeuvres complètes* (Vol. 1: 1908-1912; pp. 51–64). Paris: Payot, 1968.

Laplanche, Jean. (1987). *Nouveaux Fondements pour la psychanalyse*. Paris: Presses Universitaires de France.

Winnicott, Donald W. (1969). Development of the theme of the mother’s unconscious as discovered in psychoanalytic practice. In C. Winnicott, R. Shepherd, M. Davis (Eds.), *Psychoanalytic explorations*. London: Karnac Books.

———. (1971). *Playing and reality*. London: Tavistock Publications.

## **WISH/YEARNING**

A wish may be described as an intrapsychic impulse accompanied by the intention to obtain some denied, forbidden, or withheld satisfaction, or to rediscover a primal satisfaction, mnemonic traces of which are unconsciously inscribed.

In *Studies on Hysteria* (1895d), and in correspondence with Wilhelm Fliess in May 1897, Freud employed the term *wish* to designate a forbidden desire, speaking, for example, of the “wish to be ill” and especially of the “death wish.” This meaning was paramount in chapter 5 of *The Interpretation of Dreams* (1900a), in the section on “Dreams of the Death of Persons of Whom the Dreamer is Fond” (p. 248ff), and again in *The Psychopathology of Everyday Life* (1901b) at the conclusion of chapter 8, where it is considered in light of a neurotic conflict.

Beginning with the seventh chapter of *The Interpretation of Dreams*, Freud placed increasing emphasis on a more precise definition of the *wish*, which became highly influential in the development of psychoanalytic theory. Dream analysis determined, in effect, that the wish was produced by unconscious mnemonic traces that were fixed indelibly by the earliest experiences of infantile satisfaction. The aim of the wish is to recreate that experience, following paths laid down by primary process thought, taking into account the “logic” of unconscious drives to bypass censorship. The wish accomplishes this by being articulated in the language of the most profoundly cathected ideas. This is what led Freud to define the dream as hallucinatory wish-fulfillment.

GÉRARD BONNET

*See also:* Aphanisis; Conflict; Demand; Experience of satisfaction; Kantianism and psychoanalysis; Prohibition; Transgression; Wish-fulfillment.

### **Bibliography**

Freud, Sigmund, and Breuer, Josef. (1895d). Studies in hysteria. *SE*, 2: 48–106.

———. (1900a). The interpretation of dreams. Part I, *SE*, 4: 1–338; Part II, *SE*, 5: 339–625.

———. (1901b). The psychopathology of everyday life. *SE*, 6.

### **Further Reading**

Holt, Robert R. (1976). Drive or wish? A Reconsideration of the psychoanalytic theory of motivation. *Psychological Issues*, 36, 158–197.

Rubinstein, B.B. (1996). On the concept of an unconscious wish. *Psychological Issues*, 62, 541–550.

Simon, B. (1986). Power of the wish and the wish for power. *Psychoanalytic Inquiry*, 6, 119–132.

## WITCH OF METAPSYCHOLOGY, THE

Harking back to a remark of Freud's, "Witch Metapsychology" is occasionally invoked in an ironic or critical way to characterize the resort to general metapsychological principles as a way of avoiding some difficult problem.

In his article "Analysis Terminable and Interminable," Freud posed the following question: how, in the course of the analysis, can an instinct be "tamed"—that is to say, not suppressed, but brought, with its conflicts, "completely into the harmony of the ego." "It is not easy to find an answer," he wrote. "We can only say: 'So muss denn doch hie Hexe dran!' [We must call the Witch to our help after all!]"—the Witch Metapsychology. Without metapsychological speculation and theorizing—I had almost said 'phantasying'—we shall not get another step forward. Unfortunately, here as elsewhere, what our Witch reveals is neither very clear nor very detailed" (1937c, p. 225; the quotation is from Goethe's *Faust*).

And indeed Freud leaves his question unanswered in this paper, except for one sentence where he evokes the opposition between primary and secondary processes. This evasion is characteristic of the very problem he poses in the above-cited passage: when psychoanalytical thought runs into some difficulty or other (theoretical, practical, or technical), it is often tempted to wriggle out by invoking metapsychological principles of great generality. Their very generality renders the response of the "Witch" uncertain, however, for both question and answer can be reframed in such a way as to achieve harmony, opening the door wide to ill-defined disputes among the psychoanalysts themselves with no clear criteria to guide the discussion.

Over and above her picturesque quality, therefore, the Witch metapsychology raises a basic epistemological problem.

ROGER PERRON

See also: "Analysis Terminable and Interminable"; Goethe and psychoanalysis; Literary and artistic creativity; Science and psychoanalysis.

## Bibliography

Freud, Sigmund. (1937c). Analysis terminable and interminable. *SE*, 23: 209–253.

## WITTELS, FRITZ (SIEGFRIED) (1880–1950)

Austrian physician and psychoanalyst Fritz (Siegfried) Wittels was born in Vienna on November 14, 1880, and died on October 16, 1950, in New York.

The son of a stockbroker who claimed to be a descendant of Chaim Vital, a seventeenth-century Jewish cabbalist, Wittels attended the University of Vienna beginning in 1898 and completed his medical studies in 1904. He subsequently practiced at Vienna General Hospital and, in 1907, became assistant to Julius Wagner von Jauregg.

From 1905, Wittels attended Sigmund Freud's lectures, and in the spring of 1906 his uncle by his father's second marriage, Isidor Sadger, introduced him to the circle that by then had formed around Freud.

While a member of the Psychological Wednesday Society, Wittels also actively collaborated with Karl Kraus on his satirical review *Die Fackel*. Kraus's criticisms of psychoanalysis from 1908 were not aimed at Freud, whose ideas he valued, but mocked the reductive application of psychoanalytic ideas to literature and art, such as found in publications by Sadger, Wilhelm Stekel, and Otto Rank. However, close ties with both Kraus and Freud affected Wittels's relationship with both; a further complication was a young Viennese actress, Irma Karczewska.

Wittels's ambivalence toward Kraus apparently contributed to the latter's critical attitude towards psychoanalysis; it did not arise suddenly, as legend had it, after Wittels, in a lecture before the Vienna Psychoanalytic Society, criticized *Die Fackel* as a neurotic symptom. The love triangle comprised of Wittels, Karczewska, and Kraus led to a rupture between the two men. Later, Wittels began work on his roman-à-cléf, *Ezechiël der Zugereiste* (Ezekiel the alien), through which he hoped to avenge himself upon his former friend. Kraus attempted to stop publication of the novel by legal means and Freud himself tried to persuade Wittels to forego publication, from fear that it would drag psychoanalysis into a damaging conflict with Kraus. Freud's words, "You are impossible in my

circle if you publish this book,” quoted by Wittels in his memoirs (Timms, 1995, p. 98), led to Wittels’s resignation from the Vienna Psychoanalytic Society in 1910.

Wittels had tried to attract private patients as early as 1908, but with little success and, with time out for World War I, he continued to practice as a psychiatrist and resident neurologist at the Cottage Sanatorium in Vienna. He had a long friendship with Rudolf von Urbantschitsch, the head of the sanatorium, whom he introduced to psychoanalytic circles about 1907.

Wittels spent the First World War in Turkey and Syria as military physician. During and after the war, he lent strong support to the social reformist ideas of Josef Popper-Lynkeus. He also became close to Wilhelm Stekel and his group, and during the early 1920s he was analyzed by Stekel. Wittels’s biography of Freud, partly the result of collaboration with Stekel, was published in 1924, and soon published in England and America. *Sigmund Freud: His Personality, His Teaching, His School* won bitter remarks from Freud, but Wittels nevertheless returned to the Vienna Society in 1925, and two years later he was readmitted as a member. After his reconciliation with Freud he made some corrections and emendations to his biography (1932).

In 1927, Wittels was elected to the propaganda committee of the Vienna Society and directed its publications. He was invited in 1928 by Alvin Johnson to teach at the New School for Social Research in New York; over the next three years he lectured in the United States and in 1932 settled definitively in New York where, the same year, he became a member of the New York Psychoanalytic Society. He made his last visit to Europe in 1934, remaining a member of the Vienna Society until 1936. He joined to the American Psychoanalytic Association and the New York Academy of Medicine; he taught at the New York Psychoanalytic Institute and the New School; and he was also associated with Bellevue Hospital in New York and Columbia University.

Wittels married three times. His first wife, whom he married in 1908, was Yerta Pick, the daughter of a renowned psychiatrist in Prague; she died in 1913. In 1920 he wed Lilly Krishaber; and in 1947, he married Poldi Goetz.

Wittels’s last book, *The Sex Habits of the American Women*, was published posthumously in 1951. In 1995 Edward Timms published *Freud and the Child*

*Woman*, a highly edited version of Wittels’s not entirely frank or reliable memoirs (Lensing, 1996).

ELKE MÜHLEITNER

*See also:* Applied psychoanalysis and the interaction of psychoanalysis; *Fackel, Die*; Death instinct (Thanatos); Kraus, Karl; Wiener psychoanalytische Vereinigung.

### Bibliography

- Lensing, Leo A. (1989). “Geistige Väter” und “Das Kindweib.” Sigmund Freud, Karl Kraus und Irma Karczewska in der biographie von Fritz Wittels. *International Forum of Psychoanalysis*, 30, 430–431.
- . (1996). “Freud and the child woman” or “The Kraus affair”? A textual “reconstruction” of Fritz Wittels’s psychoanalytic autobiography. *German Quarterly*, 69 (3).
- Mijolla, Alain de. Freud, biography, his autobiography, and his biographers. *Psychoanalysis and History*, 1 (1), 4–27.
- Mühlleitner, Elke. (1992). *Biographisches Lexikon der Psychoanalyse (Die Mitglieder der Psychologischen Mittwoch-Gesellschaft und der Wiener Psychoanalytischen Vereinigung (1903–1938))*. Tübingen: Diskord.
- Timms, Edward. (1986). *Karl Kraus, apocalyptic satirist: Culture and catastrophe in Habsburg Vienna*. New Haven, CT: Yale University Press.
- . (Ed.) (1995). *Freud and the child woman: The memoirs of Fritz Wittels*. New Haven, CT: Yale University Press.
- Wittels, Fritz. (1924). *Sigmund Freud, his personality, his teaching, his school*. London: Allen & Unwin.
- . (1932). Revision of a biography. *Psychoanalytic Review*, 19, 241–256.

---

### WITTKOWER, ERIC (1899–1983)

Eric Wittkower, although a British subject by birth, was born on April 4, 1899, in Berlin and died on January 6, 1983 in Montreal.

He received his MD at the University of Berlin in 1924. From 1925 to 1930 he was assistant in the Medical Clinic at the Charité in Berlin; from 1930 to 1933 he became assistant in the Psychiatric Clinic at the Charité. From 1932 to 1933 he was privat dozent in psychosomatic medicine at the University of Berlin. Already he numbered among the European pioneers in psychosomatic medicine.

Because of the situation in Germany, in 1933 he and his wife Claire moved to Switzerland, and



thereafter on to England, where he first was a research fellow at the Maudsley Clinic and then at Tavistock. After further training in Edinburgh and Glasgow, he served as a psychiatrist in the British Army from 1940 to 1945. In England, he was analyzed by Eva Rosenfeld, then by John Rickman, and completed his psychoanalytic training at the London Institute in 1950. In 1951 the Kleinian—oriented Wittkower left Maudsley and Tavistock to go with his wife and two children to Montreal, where he taught at McGill University where he conceptually organized the domain of transcultural psychiatry and where he founded and edited the *Transcultural Psychiatric Research Review*. He was also one of the founding fathers of the Canadian Society of Psychoanalysis. In 1970 he helped to found the International College of Psychosomatic Medicine.

The prolific Wittkower authored four books, including *Emotional Factors in Skin Disease* (1953), *Recent Developments in Psychosomatic Medicine* (1954), *Divergent views in Psychiatry* (1981), co-edited three more, and wrote more than two hundred and thirty articles, the great majority being on psychosomatic medicine and transcultural psychiatry. Despite those seminal contributions and his honorary recognition by various psychoanalytic, psychiatric, and psychosomatic organizations on four continents, he prized his teaching most of all—his grateful colleagues and students overwhelmingly agree.

PATRICK MAHONY

See also: Canada; Tavistock Clinic.

### **Bibliography**

- Wittkower, Eric. (1953). *Emotional Factors in skin disease*. New York: Paul Hoeber.
- Wittkower, Eric, and Cleghorn, Robert (Eds.). (1954). *Recent developments in Psychosomatic Medicine*. London, Sir Isaac Pitman.
- Wittkower, Eric, and Dongier, Maurice (Eds.). (1981). *Divergent views in Psychiatry*. Baltimore, MD: Harper & Row.

**“WOLF MAN”**. See **From the history of an infantile neurosis (Wolf Man)**

## **WOLFENSTEIN, MARTHA (1911–1976)**

Martha Wolfenstein, a psychoanalyst and writer, was born on November 10, 1911, in Cleveland, Ohio, and died on November 30, 1976, in New York. She graduated from Radcliffe College, and then earned an MA in psychology and a PhD in aesthetics from Columbia University. She was analyzed by the art historian and lay analyst Ernst Kris and attended classes at the New York Psychoanalytic Institute between 1948 and 1953. A lay psychoanalyst, she was not a member of a society belonging to the American Psychoanalytic Association, but nonetheless was a widely admired teacher and supervisor in New York City.

Wolfenstein’s mother died when she was a child, and there is a history of parental (especially maternal) loss extending back several generations in her family. Ellen Handler Spitz has written insightfully about this history and its role in Wolfenstein’s work. Wolfenstein wrote three classic papers on childhood bereavement: “How Is Mourning Possible?” (1966b), “Loss, Rage, and Repetition” (1969), and “The Image of the Lost Parent” (1973). She also wrote important studies of two artists: René Magritte and Francisco de Goya. In her paper, “Goya’s Dining Room” (1966a), she explicated the psychological fantasies portrayed in Goya’s paintings and argued that for Goya the loss of his hearing was linked to his earlier losses, in their infancy, of all but one of his five children. She linked themes of grief, rage, and sexual guilt to the horrifying images that characterize the paintings that Goya painted after his illness in 1792.

Wolfenstein books include *Movies* (1950), *Children’s Humor* (1954), and *Disaster* (1957), a seminal analysis of the impact of catastrophic events on individuals. With the anthropologist Margaret Mead, she edited *Childhood in Contemporary Cultures* (1955). This volume grew out of the project Columbia University Research in Contemporary Cultures, led by Mead and Ruth Benedict. As a member of this project, Wolfenstein made two trips to Paris in 1947 and 1953. While in Paris she observed the behavior of parents and children in parks and noted in her paper “French Parents Take Their Children to the Park” (1955) that French children quickly learn that displays of physical aggression are not permissible, and that verbal disputes are substituted. She concluded that for the French, childhood and adulthood are very distinct, and that the relation between childhood and adulthood is almost completely

opposite in France and in America. In America, childhood is viewed as a nearly ideal time, and adults feel nostalgic for their childhood. Adulthood is a ceaseless round of work, and the enjoyment of immediate pleasures is nearly lacking. For the French, the opposite is true: it is in adulthood that one can live in the present moment and that sensuous pleasures become ends in themselves; concern with such pleasures and ingenuity in achieving them are persistent themes of adult life.

Wolfenstein's books and essays are exemplary for their use of psychoanalytic insights as a prism with which to illuminate and connect the origins and vicissitudes of cultural values and attitudes to psychological imperatives. Her papers on childhood bereavement were important clinical contributions because they demonstrated that the child's or adolescent's inability to fully engage in mourning the loss of a beloved object, as opposed to adapting, is inextricably linked to their particular stage of development at the time of the parent's death.

NELLIE L. THOMPSON

### Bibliography

- Spitz, Ellen Handler. (1998). Martha Wolfenstein: Toward the severance of memory from hope. *Psychoanalytic Review*, 85, 105–115.
- Thompson, Nellie. (2001). American women psychoanalysts, 1911–1941. *Annual of Psychoanalysis*, 29, 161–177.
- Wolfenstein, Martha. (1954). *Children's humor: A psychological analysis*. Glencoe, IL: Free Press.
- . (1955). French parents take their children to the park. In Margaret Mead and Martha Wolfenstein (Eds.), *Childhood in contemporary cultures* (pp. 99–117). Chicago: University of Chicago Press.
- . (1957). *Disaster: A psychological essay*. Glencoe, IL: Free Press.
- . (1966a). Goya's dining room. *Psychoanalytic Quarterly*, 35, 47–83.
- . (1966b). How is mourning possible? *Psychoanalytic Study of the Child*, 21, 93–123.
- . (1969). Loss, rage, and repetition. *Psychoanalytic Study of the Child*, 24, 432–462.
- . (1973). The image of the lost parent. *Psychoanalytic Study of the Child*, 28, 433–456.
- Wolfenstein, Martha, and Leites, Nathan. (1950). *Movies: A psychological study*. Glencoe, IL: Free Press.

### WOLFF, ANTONIA ANNA (1888–1953)

Swiss analyst Antonia (“Toni”) Anna Wolff was born on September 18, 1888, in Zürich, where she died on March 21, 1953. Wolff was the oldest of three daughters born to Konrad Arnold Wolff and Anna Elisebetha Sutz. The Wolff family had resided in Zürich since the 1300s and was one of its most distinguished names. The family had been members of the Swiss Reform Church for many centuries. Konrad had been a merchant and a businessman in Japan prior to his marriage. Although the marriage was arranged, it has been described as a happy one. Wolff was her father's favorite. When he died in 1910, her mother sent her to Jung for treatment of what today would be diagnosed as depression. Jung immediately sensed her aptitude for analysis, because in 1911 he invited her, along with his wife and several other women that showed promise, to the Weimar Psychoanalytic Congress.

When Jung began his *nekyia* into the unconscious, Wolff was the one he turned to. He shared his dreams and active imaginations with her, which he recorded in his Red Book. She became his soul mate for psychological matters in a way that Emma could not provide. She maintained this function for most of the rest of his life. Jung described her as his “second wife.” Jung's relationship to Wolff was completely public, and all immediate members of the Jung family, including Emma, were aware of the situation. Emma and Wolff often sat on either side of Jung when he gave a seminar, and Toni frequently traveled with Jung on his lecture tours. This arrangement did not sit well with the children and grandchildren, but it was completely accepted by Jung's analysts. It has been said that Jung, as he got older, turned to her less frequently.

She became a founding member of the Analytical Psychology Club in 1916 and was its president from 1928 to 1945. It was under her presidency that the ten-percent quota on Jews was passed. From 1948 to 1952 she was honorary president of the club. The club, the only Jungian organization at the time, was her domain.

From the 1920s on she worked as a professional assistant to Jung. Most people who entered analysis with Jung also saw her. She was considered to be more practical and worked in the personal aspects with the analyst, whereas Jung dealt mainly with the archetypal issues. She favored the term *Complex Psychology* over any other name for Jung's psychology, and when the Jung Institute was founded she wanted to name it the

“Institute for Complex Psychology”. Her major paper was, “Structural Forms of the Feminine Psyche,” published in German in 1951 and translated into English by Paul Watzliwack. As of 2005 her other papers were being prepared for publication in English by Robert Hinshaw.

On a personal level she was always described as elegant, and dramatic in her dress; a chain smoker who liked her cocktails, but was never drunk. She never married, as Jung was the man in her life. There were rumors of other flirtations, but nothing has been verified. She suffered from severe rheumatoid arthritis, which hampered her mobility toward the end of her life. She worked until the day she died. Gerhard Adler described having an excellent analytic hour with her the day before she suffered her fatal heart attack on March 21, 1953.

THOMAS KIRSCH

*See also:* Jung, Carl Gustav.

## WORD ASSOCIATION

Word association is connected with the work that Carl Gustav Jung was engaged in at the Burghölzli Psychiatric Clinic of the University of Zurich in the early stages of his career (Jung, 1917/1926/1943). Under the directorship of Eugen Bleuler, the Burghölzli Psychiatric Clinic was an international center of excellence in psychiatric research at the turn of the century. Jung became director of research on the Word Association Test. This test usually consisted of a hundred stimulus words that were read out singly to a subject who was to “answer as quickly as possible with the first word that occurs to you.” The reaction time, verbal response, and test behavior were recorded and analyzed. Verbal responses were classified according to several linguistic categories. The test was used to diagnose psychological typology and psychopathology.

The Word Association Test (WAT) was based on earlier theories of the associationism school of psychology, which studied the laws of mental associations.

Jung introduced significant innovations to this method. In addition to the cognitive dimensions, he emphasized the emotional aspects involved. He noted that the words to which subjects offered unusual

responses were connected with themes having an emotional impact on them. He found that subjects invariably do not have conscious control over their responses. Therefore, he argued, this method was tapping both conscious and unconscious phenomena. He found that clusters of ideas, images, and words loaded with much affect (positive or negative) interfered with the ego (as the coordinating agency) by producing unusual responses. He called these clusters *complexes*. Jung used Freud’s theories of repression to account for the autonomous nature of complexes. Freud praised Jung for providing experimental proof of the existence of the unconscious, welcoming him in the early psychoanalytic movement as a much needed hard-nosed scientist. Although the term *complex* was used by Freud and Josef Breuer earlier, it was with Jung’s meaning that it finally entered the psychoanalytic vocabulary.

Jung and his associates applied the Word Association Test to many psychiatric contexts, including forensic diagnoses, publishing some remarkable cases of successful detection. A much-neglected facet of Jung’s early work is his application of this method to families. He gave the test to members of the same families and found that there were psychological subgroupings in the same family. At the time, however, Jung possessed neither the theoretical understanding nor the clinical experience to take these findings further. One can argue that these unfinished questions contributed to the development of his theories about other manifestations of shared unconscious structures in subjects, for example, the archetypes (Papadopoulos, 1996).

Gradually, Jung abandoned this method and the whole experimental approach to psychiatry, especially after leaving the Burghölzli Psychiatric Clinic. Nonetheless, his method of amplification (instead of free association) and his sensitivity to the role of language in psychotherapy owe their origin to the Word Association Test. As of 2005, the Word Association Test is hardly used, though it is taught in some Jungian training programs and some analysts use it as a technique to enhance the therapeutic process (Hill, 1975).

RENOS K. PAPADOPOULOS

*See also:* Amplification (analytical psychology).

### **Bibliography**

Hill, John. (1975). Individuation and the association experiment. *Annual of Archetypal Psychology*, 145–151.

Jung, Carl Gustav. (1917/1926/1943). The psychology of the unconscious processes. In *Coll. Works*, Vol. 7: *Two essays on analytical psychology* (R. F. Hull, Trans.). London: Routledge and Kegan Paul, 1953.

Papadopoulos, Renos K. (1996). Archetypal family therapy: Developing a Jungian approach to working with families. In Laura S. Dodson and Terrill L. Gibson (Eds.), *Psyche and family: Jungian applications to family therapy*. Wilmette, IL: Chiron Press.

## WORD-PRESENTATION

In the Freudian model, *word-presentations* correspond to verbal language, and *thing-presentations* correspond to visual images. They differ as signifier differs from signified. In Freud's view, although unconscious thing-presentations and thought antedate word-presentations, which are preconscious-conscious, he assigned a special role to verbal language in the mechanism whereby unconscious processes *became* conscious.

In the associationist perspective of his prepsychoanalytic work, in particular, in *On Aphasia* (1891b), where Freud first presented the antithesis between thing- and word-presentations, the thing-presentation constituted an open complex of images, whereas the word-presentation was a closed entity whose special task was to gather the "associations of the object" together as the "complex" that constituted the object's identity. What Freud was apparently referring to here was less the presence of something being represented than the difference between two series of associations, one of which is closed and the other open-ended. The specific role of language is to produce meanings that lie not in things prior to the advent of language but rather in thought before the advent of words.

Upon discovering the unconscious, Freud came to question this nominalist theory of knowledge, inherited from John Stuart Mill, and embraced the idea that unconscious thinking, and by extension thing-presentations, were prior to language and word-presentations. At the same time, however, spoken language acquired a privileged role in the mental processes whereby things become conscious. As early as "A Project for a Scientific Psychology" (1950c [1895]), the word-presentation was seen as a substitute for the hallucinatory satisfaction of a wish. This theoretical conception of the relationship between pleasure and language comports with psychoanalytic clinical

practice: in *Studies on Hysteria* (1895d), Freud said that in the treatment process there is a need to replace acts with words to permit the abreaction of repressed wishes. Freud thus stressed how the motor aspect of language can facilitate an emotional release, in connection with the revival of a memory, that is less costly than alternative adequate reactions (tears, revenge, etc.).

Seen in this light, language constitutes the secondary process (the processes of the ego) and the process of emergence into consciousness, though it is true that Freud never denied the possibility of thing-presentations becoming conscious directly, as for instance in dream images and hallucinations. Verbal thinking nevertheless remained the ideal tool of psychoanalysis, for it allows all parts of the psychic apparatus to be accessible at all times to the thought process. In fact, the impartiality of language makes it possible for the demands of the pleasure principle to be placed in abeyance.

No doubt this property of language later spurred Freud to assert that word-presentations, by virtue of the "hypercathexis" of thing-presentations, "make it possible for the primary process [the processes of the id] to be succeeded by the secondary process" and for "a higher psychical organization" to emerge, namely the preconscious system (1915e, p. 202). In "An Outline of Psychoanalysis" (1940a [1938]), however, he proposed a more restricted view, arguing that language did not in fact constitute the preconscious, though it was an important feature of it. He then acknowledged that for language to develop, the secondary process and the ego must have organized and there must also be in place a preverbal form of thinking correlated with the economic equilibrium between the principles of inertia and constancy. In this connection, in the "Outline" Freud spoke of the opposition between free and bound energy (p. 164), thus confirming his view that at an early, prelinguistic stage, the preconscious-conscious system binds the affects with ideational representatives in a process that is the corollary of primal repression. In this context, Freud viewed preconscious thought as depending on the formation of the categories of space, time, causality, and permanence during the first two years of life, categories that supply the foundation for the development of language.

Should we subscribe to Jacques Lacan's view that language is the precondition of the unconscious and that with regards to the mental organization necessary to constitute objects, "it is the world of words that creates the world of things" (2002 [1953], p. 65)? Or

should we determine instead that the unconscious is a prerequisite of language, that the organization of the topography of the mental apparatus precedes and accounts for the emergence of language? The issue is important, for it decides the status of language relative to the discovery of the unconscious and of childhood sexuality.

The crux of the question is Freud's conception of the thing-presentation. The empiricist notions Freud employed tend to reinforce the idea that the thing-presentation refers only to the mental reproduction of things, just as the concepts of image and mnemonic trace suggest. Contrasting with this Freudian empiricism is Lacan's promotion of an unconscious "structured like a language"—an intellectualizing approach according to which language gives the world meaning.

Both approaches lose sight of the fact that thing-presentations are the outcome of the psychic work of internalizing and reappropriating mnemonic traces bound up with the hallucinatory satisfaction of wishes. This work of representing and figuring the object is the foundation of fantasizing and has its roots in cathectic activity that antedates perception of objects. The object presents itself in the first instance by way of an affect. This totality can never be represented figuratively in a complete way or expressed in words in a discourse adequate to it.

In its relationship with the secondary process, language appears defined essentially by its communicative function. But it is at the same time subject to the primary process, which tends to strip it of this function and to bring into question the signifying-signified relationship, thus introducing a factor ultimately against the linguistic system itself. When a similarity between signifiers serves to justify a conclusion that the things signified are similar, words, as Freud famously observed, are "treated like things" (1900a, pp. 295–296; 1915e, p. 199). Freud's study of dreams and psychoneuroses brought him to this view. Yet dreams only partially bring into question the relationship between signifier and signified, between word-presentation and thing-presentation. As Freud reiterated, dreams modify not the "words themselves" but rather "the thing-presentations to which the words have been taken back" (1916–1917f, p. 229). In short, "treating words as things" means making words not into things but into other words, other signs, that retain their referential function despite successive substitutions.

The primary process, meanwhile, can also alter the relationship between the linguistic sign and the referent. For example, in schizophrenia the elimination of the semantic relationship between signifier and signified also threatens the linguistic sign in its referential function to a thing in the external world. Indeed, psychosis implies a failure in the counter-cathexis of the hallucinatory representation of wishes, which makes it possible for the preconscious to operate. This failure gives rise to a defensive hypercathexis of language, which, though it constitutes an attempt at recovery by "regaining the lost object" (1915e, pp. 203–204), nevertheless relies on a like massive cathexis of the object.

In this context, any word may carry the excitatory force of the primal scene, that is, the force of a sadistic combination of two poorly differentiated imagos. In the thought of schizophrenics, hypercathexis of language is basic to their linguistic distortions and "concrete" thinking, which in actuality, from the point of view of the relationship between language and reality, is an eminently abstract kind of thought. But concrete schizophrenic thought can foster the illusion that language is forever cut off from the world, whereas in fact the sign can have no meaning outside of that opening onto the outside world (thought) that is its very foundation.

The symbolic function, and hence language, are linked to an economic process indicated by instinctual cathexis. Freud's description (1920g, pp. 14ff) of an eighteen-month-old child playing with a reel on a string (the *Fort-Da* game) shows how, in this economic process, the work of symbolic substitution operates by means of signs that represent the mother's absence and indicate acceptance of this fact, as distinct from mere signals (as for instance the child's earlier tears), which are addressed to a mother who is effectively present and are meant as a practical response. Inhibition of the aim of the instinct, which results in a shift to tender feelings toward the object and acceptance of a delay in satisfaction, then allows sublimation and symbolization through play, gesture, and language.

Thus the symbolic function, seen here in the process of the subject's working over the absent object, does not arise from a learning process or from an experienced contiguity between word and thing. Rather, it is the means of articulating the double nature of the sign and its differential value in the linguistic system. This symbolic function is achieved through the work of negation carried out in silence, manifesting itself notably in the early split between ego and object, and find-

ing its true fulfillment, as distinct from its *raison d'être*, in language. As it accedes to speech, this representational function has less to do with language reduced to its role as signal than it does with language as sign, with the sort of sudden advance that can sustain the acceptance not only of a loss but also of a previously instituted social convention regarding the loss.

ALAIN GIBEAULT

*See also:* Thing-presentation.

### **Bibliography**

- Freud, Sigmund. (1891b). *On aphasia: A critical study*. New York: International Universities Press.
- . (1915e). The unconscious. *SE*, 14: 159–204.
- . (1916–1917f [1915]). A metapsychological supplement to the theory of dreams. *SE*, 14: 217–235.
- . (1920g). Beyond the pleasure principle. *SE*, 18: 1–64.
- . (1940a [1938]). An outline of psycho-analysis. *SE*, 23: 139–207.
- . (1950c [1895]). A project for a scientific psychology. *SE*, 1: 281–387.
- Freud, Sigmund, and Breuer, Josef. (1895d). Studies on hysteria. *SE*, 2: 48–106.
- Lacan, Jacques. (2002). The function and field of speech and language in psychoanalysis. In his *Écrits: A selection* (Bruce Fink, Trans.). New York: W. W. Norton. (Original work published 1953)

## **WORK (AS A PSYCHOANALYTICAL NOTION)**

In its general sense, the word *work* denotes an expenditure of energy by a system or organism that produces an effect or transformation. In psychoanalysis, mental work is taken to mean any activity of the psychical apparatus that is designed to deal with instinctual excitations.

As early as “Some Points for a Comparative Study of Organic and Hysterical Motor Paralyses” (1893c), a paper originally published in French, Freud introduced a notion cardinal to his entire work: “Every event, every psychical impression is provided with a certain quota of affect (*Affektbetrag*) of which the ego divests itself either by means of a motor reaction or by associa-

tive psychical activity.... [T]his conception (*Vorstellung*) does not become liberated and accessible so long as the quota of affect of the psychical trauma has not been eliminated by an adequate motor reaction or by conscious psychical activity” (pp. 171–172). It was therefore on the basis of clinical experience that the idea of mental work imposed itself on Freud the therapist as a necessary activity for the patient—as distinct, in particular, from the patient’s more passive role in treatment using hypnosis. In his earliest psychoanalytical writings, it was a cognitive kind of work that was seen as making it possible to resolve the contradiction between an unacceptable idea that had aroused a painful affect and the ego. The aim of such “associative working over (*assoziative Verarbeitung*)” (1894a, p. 50) was to integrate forgotten ideas—which Freud would later call *repressed ideas*—into the realm of consciousness.

By drawing this distinction between associative mental work and a motor discharge comparable to the reflex arc, Freud not only described the aim of such work, namely to deal with the quota of affect, but also offered a first glimpse of what was to become psychoanalysis: the study of the functioning of the psychical apparatus, and at the same time a therapeutic method designed to bring back into consciousness, by means, precisely, of psychic work, ideas that had been repressed. The term *work* appears frequently in Freud’s writings, and very often it refers to one or other of these two aspects of psychoanalysis.

It is significant that Freud chose a term belonging at once to ordinary and to scientific language in order to describe his view of the psychical apparatus: by analogy with the natural sciences, which he so often invoked, he took *work* to mean a physical measure implying a certain expenditure of energy. Throughout Freud’s writings, in fact, the idea of work supplied him with the yardstick with which to gauge every manifestation of mental activity, not only within the treatment (the work performed respectively by analyst and analysand, as discussed for example in the *Studies on Hysteria* [1995d]), but also in respect of the operation of various mental processes (as for instance the dream-work, joke-work, the work of mourning, or the psychic work of repression in the child during the oedipal period).

Beginning with *The Interpretation of Dreams* (1900a), Freud considered—“since nothing but a wish can set our mental apparatus at work” (p. 567)—that the dream was a wish-fulfillment, and that it was governed by the pleasure principle. The task of the dream-work,

whose chief mechanisms Freud described as condensation, displacement, considerations of representability, symbolization, and secondary revision, was to transform the formative components of dreams—daily residues, bodily stimuli, dream-thoughts—into a manifest content acceptable to the otherwise vigilant consciousness of the dreamer. In *Jokes and Their Relation to the Unconscious* (1905c), Freud discussed the work involved in the construction of jokes, an activity designed to produce pleasure, and demonstrated its kinship with the mechanisms of the dream. The *Three Essays on the Theory of Sexuality* (1905d) introduced the sexual instinct as a way of conceptualizing the pressure for work mobilized by desire; the work of the psychic apparatus was thus deemed to be the management of excitations emanating from the sexual instinct.

In “Formulations on the Two Principles of Mental Functioning,” (1911b), Freud reasserted that the activity of the psychological apparatus was governed by the pleasure principle, but he added that in the course of development the reality principle could establish itself and modify things: “Just as the pleasure-ego can do nothing but *wish*, work for a yield of pleasure, and avoid unpleasure, so the reality-ego need do nothing but strive for what is *useful* and guard itself against damage” (p. 223). Later, in “Mourning and Melancholia” (1916–17g [1915]), Freud showed that mourning was responsible for the work of withdrawing libido from the object in situations where the object was highly cathected.

The word *work* was used throughout Freud’s writings, too, to denote effort expended during analytic treatment, whether by the analyst or by the patient. In his paper on “Constructions in Analysis,” for example, he reminded his readers “that the work of analysis consists of two quite different portions, that it is carried on in two separate localities [and] involves two people, to each of which a distinct task is assigned.” Moreover, the “person who is being analysed has to be induced to remember something that has been experienced by him and repressed; and the dynamic determinants of this process are so interesting that the other portion of the work, the task performed by the analyst, [may be] pushed into the background” (1937d, p. 258). The analyst’s said task Freud nevertheless compared first of all to that of the archaeologist; he then distinguished between two kinds of work on the analyst’s part that were undertaken in parallel: construction (or reconstruction) and working-through (*durcharbeiten*), the

second being needed in order to overcome the resistances that the analyst’s constructions were liable to provoke in the patient.

Finally, Freud did not overlook the everyday meaning of *work* as professional activity. Like Voltaire, whom he cited, he underscored the great value of work in this sense, but for his part he viewed it from the standpoint of the economics of the libido, and described it as a form of sublimation offering the possibility “of displacing a large amount of libidinal components, whether narcissistic, aggressive or even erotic”; to the extent that it made possible “the use of existing inclinations . . . or . . . instinctual impulses,” any profession could be “a source of special satisfaction” (1930a [1929], p. 80n).

Many recent approaches to psychoanalysis have given a significant place to the notion of work. A notable example is André Green’s “work of the negative,” which, though it is a product of the death instinct, functions in a sense by making the negative positive: a void, a lack, or a state of mourning itself becomes an object of identification or an object susceptible of cathexis, to the detriment of the absent object itself. Negative hallucination, the function of disobjectalization, negative narcissism, or the complex of the dead mother are so many paradigms of the work of the negative in operation.

René Angelergues (1993) has distinguished between two qualitative orientations of mental work, the one toward sublimation, the other toward erotization. It is also worth mentioning the “work of thought” (Anzieu, 1996; Mijolla-Mellor, 1992). And, lastly, the phenomenon of mentalization, which, according to the *École de Psychosomatique de Paris*, deals with the quantity and quality of an individual’s ideas—and is thus closely akin to that mental work which has the capacity to cope with and manage anxiety and intrapsychic conflicts.

MICHÈLE POLLAK CORNILLON

*See also:* Adolescent crisis; Autohistorization; Construction/reconstruction; Dream work; *Interpretation of Dreams, The*; Mourning; Negative, work of; “Outline of Psycho-Analysis, An”; Preconscious, the; Secondary revision; Therapeutic alliance; Working-through.

### **Bibliography**

Angelergues, René (1993). *L’Homme psychique*. Paris: Calmann-Levy.

- Anzieu, Didier. (1996). *Créer, détruire*. Paris: Dunod.
- Freud, Sigmund. (1893c [1888–1893]). Some points for a comparative study of organic and hysterical motor paralyzes. *SE*, 1: 155–172.
- . (1894a). The neuro-psychoses of defence. *SE*, 3: 41–61.
- . (1900a). The interpretation of dreams. Part I, *SE*, 4: 1–338; Part II, *SE*, 5: 339–625.
- . (1905c). Jokes and their relation to the unconscious. *SE*, 8: 1–236.
- . (1905d). Three essays on the theory of sexuality. *SE*, 7: 123–243.
- . (1911b). Formulations on the two principles of mental functioning. *SE*, 12: 213–226.
- . (1916–17g [1915]). Mourning and melancholia. *SE*, 14: 237–258.
- . (1930a [1929]). Civilization and its discontents. *SE*, 21: 57–145.
- . (1937d). Constructions in analysis. *SE*, 23: 255–269.
- Freud, Sigmund, and Breuer, Josef. (1895d). Studies on hysteria. *SE*, 2.
- Mijolla-Mellor, Sophie de. (1992). *Le Plaisir de pensée*. Paris: Presses Universitaires de France.

---

## WORKING-OFF MECHANISMS

The term *working-off mechanisms* describes the work of the psychic transformation that is accomplished by the subject during or at the end of psychoanalytic treatment. This process, developed by the ego's new capacities for binding, indicates the attainment of a psychic liberation or opening-up.

The notion of working-off was mainly introduced by Edward Bibring (1943) in the context of what he called the “tension-controlling methods of the ego” (p. 513). Daniel Lagache (1962) later adopted and further developed it. In Lagache's view, working-off mechanisms are different from defense mechanisms, because the former indicate that the defense has been lifted. The essential point entails the “recognition and assimilation of the fantasmatic conflict,” which opens the way to the psychic capacities for “foresight” and “replacement.”

Sigmund Freud did not explicitly mention the presence of working-off mechanisms. However, in the fifth of his “Five Lectures on Psycho-Analysis” (1910

[1909]) he emphasized how unconscious wishes are liberated by psychoanalysis: a) repression is replaced “by a *condemning judgement* carried out along the best lines” (p. 53), such that the subject's ego can thereafter “master” the “unserviceable” instincts of an incompletely developed ego that could previously only repress them; b) the instincts can then “be employed for the useful purposes which they would have found earlier if development had not been interrupted” (p. 53); c) the individual's unrealizable inclination is replaced by a higher goal situated outside of sexuality: *sublimation*.

Lastly, a reference to such processes can be read between the lines in some of Freud's other texts: the chapter “The Ego's Dependency Relations” in *The Ego and the Id* (1923), and “Analysis Terminable and Interminable” (1937).

The notion of working-off mechanisms is difficult to delimit on the metapsychological level. If it implies an effort to account for the subject's capacity for integration and elaboration, it has often been understood, especially by adherents of ego psychology, as an illustration of the attitudes and behaviors of the “conscious ego.”

ELSA SCHMID-KITSIKIS

See also: Bibring, Edward; Ego (ego psychology).

## Bibliography

- Freud, Sigmund. (1910 [1909]). Five lectures on psychoanalysis. *SE*, 11: 7–55.
- . (1937). Analysis terminable and interminable. *SE*, 23: 209–253.
- Lagache, Daniel. (1962). La conception de l'homme dans l'expérience psychanalytique. In E. Rosenblum (Ed.), *Oeuvres Complètes*, Volume 4: 1956–1962: Agressivité. *Structure de la personnalité et autres travaux*; Paris: Presses Universitaires de France.

---

## WORKING OVER

Psychical working over is the work of thought that links and associates mental representations among themselves and through the intermediary of language, leading to their evolution, through the successive translations and networks of symbolic associations put into operation by fantasies, from the stage of the primary processes to that of the secondary processes. It is



an expression of the instinct's requirement for psychic work owing to its link with the somatic.

Sigmund Freud borrowed the term *psychical working over* from Jean Martin Charcot, who described a period of mental processing between the time of a trauma and the appearance of hysterical symptoms. As early as 1892, and then in the *Studies on Hysteria* with Josef Breuer (1895), Freud evokes a working out through association that has not been able to take place in hysteria, leading to stasis of the traumatic effect in a separate psychic group, with no possibility of liquidation.

The mechanism takes into account the nucleus of the actual (defense) neurosis that is central to the neuro-psychoses (in this case, hysteria). The lack of psychical working over is even more clear cut in the actual neuroses, properly speaking. In the essay "On the Grounds for Detaching a Particular Syndrome from Neurasthenia under the Description 'Anxiety Neurosis'" (1895), Freud invokes the absence of a psychical working over of sexual tension as the cause of the actual neuroses, through either excessive discharge into the soma (melancholia, neurasthenia) or excessive accumulation (anxiety neurosis).

Different levels of this work of linking and mentalization of the instincts can be described. The first level is the site of transformation of the physical quantity of an excitation tending toward immediate, reflexive discharge into a psychic quality that can be preserved and serve as a tool for thought and a guide for action. This transformation occurs through (1) the inhibitory effects of the lateral cathexes (according to Freud's 1895 "Project for a Scientific Psychology"); (2) representational translations; and (3) the mechanisms of symbolic representation of the Preconscious and censorship (according to Freud's writings from *The Interpretation of Dreams* (1900) through his essays on metapsychology [1915]). This level demonstrates the capacity of the psychic apparatus, by means of its representations, to direct and contain discharges, promote deferred action, and impose a waiting period.

The containment of free psychic energy is accomplished through fixation of that energy within representations and symbolic networks that are relatively stable. In Freud's account, memory traces form a hierarchical system of signs made up of successive strata (like the lava flows he describes in "Instincts and Their Vicissitudes" [1915]). He states this clearly in a letter to Wilhelm Fliess dated December 6, 1896, where he evokes

the "re-transcription" (1950a [1887-1902], p. 233) of memory traces at several registers—at least three, perhaps more—of signs. Each register corresponds to a temporal stage in psychic life, and the passage from one register to the next occurs by means of a process comparable to translation. Each retranscribed memory trace "inhibits its predecessor and draws of the excitatory process from it" (1950a [1887-1902], p. 235).

For Jean Laplanche and Jean-Bertrand Pontalis in their *Vocabulaire de la psychanalyse* (1967), psychical working over constitutes an important junction between the economic register (management of excitation) and the symbolic register (the network of associations) in Freud's theory of the psychic apparatus. In the view of such authors as Michèle Perron-Borelli and Roger Perron (1997), Alain Gibeault (1989), or François Duparc, this symbolic elaboration occurs by means of symbolization processes that construct a network extending from the most primitive fantasies of action to the most elaborate fantasmatic organizations: the family romance, or infantile theories of sexuality. According to Duparc (1997, 1998), each system of signs (images of motion, visual forms or representations of things, representations of words, or elaborated fantasies) has its own capacity for temporal containment, which increases with the psychic delay that precedes discharge.

But in order for psychical working over to be a flexible, creative process that is not limited to containing action and orienting the subject toward abstract signification, it must nevertheless allow for the possibility of the instinct's deployment in all its dimensions, including the affects, resonances among fantasies and representational forms, and controlled breaking of the habits of language and thought. These tertiary processes, which enable regression, have the effect of freeing language from a state of mourning. For Duparc, representation is a living process in that it transports the drives through the various resonances charged with motricity and affect, among the forms pertaining to the most primary level of symbolization (forms conveying motion, primal protofantasies), the visual forms and mechanisms of figuration that fix the instincts' movements within the censorship of the preconscious, and the elaborate forms of the rhetorical figures of language.

FRANÇOIS DUPARC

*See also:* Conscious processes; Fundamental rule; Lifting of amnesia; Memories; Memory; Psychoanalytic treat-

ment; “Remembering, Repeating, and Working Through”; Resistance; Transference neurosis; Work (as a psychoanalytic notion).

### **Bibliography**

- Duparc, François. (1997). Hallucination négative, formes motrices et comportements autocalmants. *Cliniques psychosomatiques*. Paris: Presses Universitaires de France.
- Duparc, François. (1998). *L'Élaboration en psychanalyse*. Bordeaux, France: L'Esprit du temps.
- Gibeault, Alain. Destins de la symbolisation. (1989). *Revue française de psychanalyse*, 53 (6), 1493–1617.
- Freud, Sigmund. (1950a [1887-1902]). Extracts from the Fliess papers. *SE*, 1: 173–280.
- Perron, Roger, and Michèle Perron-Borelli. (1997). *Fantasme. Action. Pensée*. Algiers, Algeria: Éditions de la Société algérienne de psychologie.

---

## **WORKING-THROUGH**

*Working-through* is the name for an operation resulting from the putting into effect of several processes during treatment; it opposes the work of resistance by making the analysand better aware, through time, of the defensive mechanisms upon which resistance is based, and it sparks “processes of remodeling the ego” (1937c, p. 249). Freud accords it a primary place in the analysand’s domain, to the extent the analyst allows him the time to accomplish it. At the same time however, this activity also seems closely tied to interpretation, and the interpretive modalities of the analyst. It is a term that may only be surmised in relation to economic principles, including those of resistance and elements of timing such as duration and “tempo.”

The German term *durcharbeiten* is difficult to translate. Although the English translation “working-through” does successfully convey its dynamic aspect, it fails to capture the aspect of work that occurs at the surface. In the technical paper “Remembering, Repeating and Working-Through (Further recommendations on the Technique of Psycho-Analysis II)” (1914g), where Freud uses the term for the first time, it was to describe a “consistent technique used today” that prevails over hypnosis because it gives up on privileging the interrogation of the patient concerning a specific problem or factor. It is a technique, writes Freud, used to study “whatever is present for the time being on the surface of the patient’s mind” (p. 147)— though this does not pre-

vent him from deploying metaphors of in-depth work in the same article. The term *durcharbeiten* thus conveys two notions whose co-existence in a single word is difficult to maintain: depth and surface.

Psychoanalytic technique came after that of hypnosis, and Freud sometimes placed the two in opposition in order to highlight ways in which Psychoanalysis represents a departure. Working-through comes out of a fundamental difference between the two techniques in that it assumes a gradual, step-by-step approach to resistance. Hypnosis circumvents the notion of resistance; it allows repressed memories to emerge but in no way involves “processes of remodeling the ego” and repression in its dimension as a part of processes of symbolization. The idea of resistance is necessary given the economic aspects of the drives, notably with regard to excesses of drive energy. But as Freud continually pointed out, the ego defends itself against dangers that are no longer current. Thus “to work through” implies the idea of a repetition that garners small quantities of energy to deal with the compulsion to repeat emanating from the id. Working-through is proposed answer to resistance in “Remembering, Repeating and Working-Through.”

That the form of resistance forwarded at the time is repression, attests to the fact that Freud conceived the psychic apparatus as highly-advanced in the realm of symbolization—flexible and effective in its ability to confront the drives. But the effectiveness of the function of working-through must be relativized in the face of difficulties involving defusions of instinct, narcissistic fragility, and deficiencies in symbolization. Although it remains true in these instances that certain forms of resistance must be recognized, interpreted, and then given up when they no longer further the ends of self-preservation; more recent analytic technique has ways of handling the transference and a conception of the framework for treatment which are based on metapsychological representations that are more complex than in 1914. Thus working-through is no longer indicated at certain times during treatment; and sometimes a poor understanding of negative elements in the transference may lead the analysis into a working-through that is intellectual and falsely effective.

Although Freud did not explicitly come back to this notion after 1920, it is useful to reconsider it while taking into account the upheavals brought about by the dual theory of the instincts and the negative currents it

entails. Although he did not use the term *durcharbeiten*, Freud reworks the idea of it in “Negation” (1925h), when confronted with the negative element that subtends a patient’s denial of the analyst’s interpretation. It would be necessary to wait until “Analysis Terminable and Interminable” (1937c) for him to explore how the joint efforts of the analyst and patient to recognize and conquer resistance run aground upon the negative factor of the “bedrock” of castration.

In theory, the more working-through can relate representational content to its corresponding affect, the more effective it is. We know that most of the defensive forms resistance takes, whether splitting, repression or negation, seek to divorce affect from representation and leave them strangers to one another. Certain defensive formations, notably those that combine splitting and negation, make working-through laborious, and its visible effects appear only in the long term. The forms then assumed by these psychic contents, ruled by resistances which stem from the instability of drive fusion, are subject to the repetition compulsion and are difficult to access by means of working-through, unless the analyst pays special attention to the psychoanalytic setting and to the analysis of his or her counter-transference.

In “Remembering, Repeating and Working-Through,” Freud optimistically stated that symptomatic repetition compulsion could be rendered “harmless,” or even “useful,” if the analyst could bring it into the “transference as a playground in which it [the repetition compulsion] is allowed to expand in almost complete freedom and in which it is expected to display to us everything in the way of pathogenic instincts that is hidden in the patient’s mind” (1914g, p. 154), where everything is accessible to the analyst’s interpretations. He cited the example of an analysis that seemed to be stuck in one place but that was actually evolving normally. What must be remembered, he then wrote, is “that giving the resistance a name could not result in its immediate cessation. One must allow the patient time to become more conversant with this resistance with which he has now become acquainted, to *work through* it, to overcome it, by continuing, in defiance of it, the analytic work according to the fundamental rule of analysis” (p. 155).

Working-through is indeed linked to the notion of time, of duration, as is pointed out again at the end of the essay: “The working-through of the resistances may in practice turn out to be an arduous task for the

subject of the analysis and a trial of patience for the analyst” (p. 155). The theme of the length of the analysis was much more explicit, if only because of its title, in the 1937 essay “Analysis Terminable and Interminable.” The justification for prolonging the length of the analytic cure is considered relative to the “acquired . . . alterations of the ego” (1937c, p. 235) in its defensive struggle with the drives. These modifications of the ego seem like fixations, and the analyst’s task is to promote the “processes of remodeling the ego” in the patient. Moreover, it is this aspect of the work of analysis that, from the analyst’s viewpoint, supports the idea that “to analyze” is “an interminable task” (p. 249).

In “An Outline of Psycho-Analysis” (1940a [1938]), Freud put the finishing touches on his metapsychological overview. The mental apparatus with its two topographies, his two theories of the drives, and his theories on anxiety constitute a complex whole, in light of which thinking about analytic technique must remain cautious.

The notion of working-through retains its full importance, provided it is conceived in relation to the notion of drive fusion and defusion and the consequences thereof, as well as in relation to the analyst’s interpretation, whether it is explicit or latent, as Jean-Paul Valabrega proposed in *La formation du psychanalyste* (The training of the psychoanalyst; 1994).

RENÉ PÉRAN

*See also:* Conscious processes; Fundamental rule; Lifting of amnesia; Memories; Memory; Psychoanalytic treatment; “Remembering, Repeating and Working-through”; Resistance; Transference neurosis; Work (as a Psychoanalytical Notion).

### **Bibliography**

- Freud, Sigmund. (1914g). Remembering, repeating and working-through (Further recommendations on the technique of psycho-analysis II). *SE*, 12: 145–156.
- . (1925h). Negation. *SE*, 19: 233–239.
- . (1937c). Analysis terminable and interminable. *SE*, 23: 255–269.
- . (1940a [1938]). An outline of psycho-analysis. *SE*, 23: 139–207.
- Valabrega, Jean-Paul. (1994). *La formation du psychanalyste*. Paris: Payot.

## WULFF, MOSCHE (WOOLF, MOSHE) (1878–1971)

Mosche Wulff (or Moshe Woolf), a physician and teacher, was born on May 10, 1878, in Odessa, Russia, and died in November 1, 1971, in Tel Aviv. The son of an German retailer, after graduating from the Lycée Richelieu in Paris and finishing his studies at a business school, Wulff undertook medical studies in 1900 in Berlin. He defended his thesis in 1905 under the direction of Theodor Ziehen.

The psychiatrist Otto Juliusburger, whom he served as assistant at the Berlin-Lankwitz sanatorium, introduced Wulff to psychoanalysis. He never underwent a training analysis proper, although Karl Abraham, who worked at the sanatorium from 1908, became his teacher. In 1911 he joined the Vienna Psychoanalytic Society, and in the same year he returned to Russia, establishing himself in Odessa. When World War I began, he left Odessa for Moscow.

In 1922, after the Russian Revolution, Wulff founded, with Ivan Ermakov among others, the Moscow Psychoanalytic Society. This organization gave birth the next year to the Russian Institute for Psychoanalysis, officially recognized in 1924. From 1922 Wulff worked as a psychoanalyst at the Second Medical Clinic of the University of Moscow.

As early as 1921 Wulff participated in creating a psychoanalytically oriented children's home, which in 1923 became a polyclinic and expanded into a state institute where training programs were available. After Lenin's death, however, rejection of psychoanalysis began to spread, eventually leading to the dissolution of the all psychoanalytic institutions and organized activity. Wulff was elected president of the Russian Institute for Psychoanalysis at the end of 1924, yet after a few months it was closed.

In 1927 Wulff left the Soviet Union. Returning to Berlin, he worked at the famous Schloss-Tegel Sanitarium, founded that year by Ernst Simmel. Under financial stress, this institution closed in 1931.

Wulff emigrated to Tel-Aviv in 1933 to found, with Max Eitingon and other members of the Vienna Psychoanalytic Society, the Psychoanalytic Society of Palestine. After Eitingon's death, Wulff served as its president from 1947 to 1954 (in 1948 it became known as the Psychoanalytic Society of Israel). He remained honorary president of the society until his death, after a long illness.

Among his most remarkable works are "Beiträge zur infantilen Sexualität" (Contributions to infantile sexuality; 1912), his frequently cited 1932 paper "Über einen interessanten oralen Symptomenkomplex und seine Beziehung zur Sucht" (An interesting oral symptom complex and its relation to addiction), and "The Child's Moral Development" (1941). He wrote in Hebrew as well as in German and English. Additional articles in English include "On Castration Anxiety" (1955) and "Fetishism and Object Choice in Early Childhood" (1946).

Mosche Wulff is mainly important for his pioneering work in introducing psychoanalysis to Russia and to Israel, where he trained a generation of analysts and psychiatrists. His translations of some of Freud's works into Russian have been reprinted in recent years. He was primarily interested in the analysis of children and in psychoanalytically inspired pedagogy. Some of his works on infantile psychology became standard works of reference for training teachers and educators.

RUTH KLOOCKE

See also: Germany; Israel; *Psychoterapia (Psixoterapija-Obozrenie voprosov lecenija I prikladnoj)*; Russia/USSR; Tegel (Schloss Tegel).

### Bibliography

- Jaffe, Ruth. (1966). Moshe Woolf: Pioneering in Russia and Israel. In Franz Alexander, Samuel Eisenstein, and Martin Grotjahn (Eds.), *Psychoanalytic pioneers*. New York: Basic Books.
- Kloocke, Ruth. (1995). Mosche Wulff, 1878–1871. *Luzifer-Amor*, 8 (16), 87–101.
- Miller, Martin. (1998). *Freud and the Bolsheviks: Psychoanalysis in imperial Russia and the Soviet Union*. New Haven, CT: Yale University Press.
- Woolf, Moshe. (1941). The child's moral development. In K. R. Eissler (Ed.), *Searchlights on delinquency* (pp. 263–272). London: Imago.
- . (1955). On castration anxiety. *International Journal of Psycho-Analysis*, 36, 95–104.
- Wulff, Mosche. (1912). Beitrage zur infantilen Sexualitat. *Zentralblatt für Psychoanalyse*, 2, 6–17.
- . (1932). Über einen interessanten oralen Symptomenkomplex und seine Beziehung zur Sucht. *Internationale Zeitschrift für Psychoanalyse*, 18, 283–302.
- . (1946). Fetishism and object choice in early childhood. *Psychoanalytic Quarterly*, 15, 450–471.





## ***YOUNG GIRL'S DIARY, A***

Probably written by Hermine von Hug-Hellmuth, a non-medical psychoanalyst who was considered a pioneer in the field of child psychoanalysis, *A Young Girl's Diary* was, upon publication, considered to be a watershed event (Sándor Ferenczi, December 26, 1919) and was highly successful. It was the first—and remained the only—book in a series entitled “Fundamental Texts on Spiritual Development,” which the new publishing company, created through the generosity of Anton von Freund, intended to publish. Because of its success the book provided considerable income.

Introduced by an anonymous “editor” who claimed to have retained the girl’s style unaltered and uncensored, it was accompanied by an enthusiastic letter from Freud, dated April 27, 1915, which stated, “This diary is a little jewel. I truly believe that we will never again penetrate with such clarity and sincerity into the movements of the soul that characterize the development of a young girl in our society in the years before puberty, in the present state of our civilization.”

The *Diary* contained the thoughts of the young “Rita,” written between the ages of eleven and fourteen and a half. Her lengthy commentary, which would be considered innocuous by twenty-first century standards, described the awakening of adolescent feelings in a girl living in Vienna at the turn of the twentieth century. The book describes, in Freud’s words, “how the secret of sexual life emerges, first obscurely, then taking complete control of the childish soul.” It is more of an interesting commentary on middle-class Viennese life and family relations during the birth of psychoanalysis.

Welcomed by Lou Andreas-Salomé (“this young girl has lifted her diary to the rank of works esteemed

for their literary value”), Stefan Zweig (“a quite remarkable document”), and the majority of critics, its authenticity was soon questioned by the psychoanalytic community. Siegfried Bernfeld began an investigation. The arguments in favor of fraud, published in August 1921 by Cyril Brut, an English critic, in the *British Journal of Psychology*, resulted in the exposure of Hermine von Hug-Hellmuth in 1922. Although she provided additional details on the presumed author, Hug-Hellmuth’s claims were not felt to be convincing, and a number of individuals—Karl and Charlotte Bühler, Josef Krug, Hedwig Fuchs—attempted to prove it was a fraud. It has come to be felt that a number of details in the diary are autobiographical.

The murder of Hermine von Heg-Hellmuth by her nephew, Rudolf Hug, on September 9, 1924, served only to intensify the swirl of rumors circulating around the work, which in spite of its success was withdrawn from publication in 1927. It was translated into English in 1927.

*See also:* Adolescence; Hug-Hellmuth-Hug von Hugenstein, Hermine; Technique with children, psychoanalytic.

### ***Source Citation***

Hug-Hellmuth, Hermine von. (1919). *Tagebuch eines halbwüchsigen Mädchen; von 11 bis 14 1/2 Jahren*. Vienna: Internationaler Psychoanalytischer Verlag; *A Young Girl's Diary*. London: Allen and Unwin; New York: Seltzer, 1924.

### ***Bibliography***

Hug-Hellmuth, Hermine von. (1911–1924). *Essais psychanalytiques* (D. Soubrenie, Ed.). Paris: Payot, 1991.

MacLean, George, and Rappen, Ulrich. (1991). *Hermine von Hug-Hellmuth*. New York-London: Routledge.

## YUGOSLAVIA (EX-)

Three men—Stjepan Betlheim, Hugo Klajn, and Nichola Sugar—born at the end of the nineteenth century are at the root of psychoanalysis in Yugoslavia. Having completed their medical studies and specialized in neuropsychiatry in Germany and Austria, their return to what was then the kingdom of the Serbs, Croats, and Slovenes marked the beginning of the spread of psychoanalytic ideas in this region. They had to contend with the resistance of the psychiatric milieu and the polite interest of the intellectuals, except in Belgrade where they met with great success in artistic circles.

Because they were Jews, these pioneers naturally found themselves in the Resistance during World War II. The victory over fascism and Nazism conferred an authority on them that translated into the creation of psychoanalytically informed treatment centers.

Psychoanalytic thinking spread very rapidly in Sarajevo under the impetus of Dr. Aleksandar Markovic, and in Ljubljana where a psychologist, Leopold Bregant, and a psychiatrist, Milan Kobal, played an important role.

A new generation of Slovene psychoanalysts was being trained in the neighboring Italian city of Trieste. But it was mainly in Croatia and Serbia that the development was decisive. The war (1991–1995) put an end, for the moment, to scientific exchanges between Serb and Croatian analysts. However, both of these groups managed under difficult conditions to maintain vital contact with Western analysts, particularly in France and Italy.

### Croatia

The history of psychoanalysis in Croatia is linked to the name of Stjepan Betlheim (1898–1970). He studied medicine in Graz and Vienna. After a first analysis with Paul Schilder, he completed his training with Sándor Radó, whom Abraham Arden Brill invited in 1932 to organize an institute of psychoanalysis in New York. Karen Horney in Berlin and Helene Deutsch in Vienna supervised Betlheim's first analyses. An "associate member" of the Vienna Psychoanalytic Society in 1928, he returned to Zagreb that same year. Until World War II he divided his time between a neuropsychiatric department and psychoanalysis in private practice. In 1948 his good reputation enabled him to introduce psychoanalysis in the medical faculty, and in 1953 to create a center for psychotherapeutic treatment in the framework of the neuropsychiatric clinic, thus offering the resources of psychoanalysis and its psychotherapeutic applications for individuals and

groups. In 1952 he was elected a "direct member" of the International Psychoanalytical Association (IPA). In 1963 he published *The Neuroses and Their Treatment*, while simultaneously campaigning for the creation of an Association of Yugoslav Psychotherapists. The first steps in this direction were taken in 1964 at the Congress of Neuropsychiatrists at Ohrid, and the project bore fruit in Split in 1968.

In the period after World War II Stjepan Betlheim personally psychoanalyzed his first students: Duska Blazevic, Eugenie Cividini-Stranic, and Edouard Klain. At the same time he created the Mokrice seminar, which, from 1966 until 1991, was a meeting place for therapists from the different Republics constituting the Federal Socialist Republic of Yugoslavia. Professor Maja Beck-Dvorzak organized the psychoanalytic treatment of children and adolescents, followed by Professor S. Nikolic, who introduced the technique of the psychoanalytic psychodrama after a stay in Paris in Serge Lebovici's department, while undergoing personal analysis with Jean Gillibert (1976–1979). In Zagreb Duska Blazevic and Edouard Klain created a psychoanalytically oriented review, *Psychoterapja*. It is the responsibility of the remaining members of this group to establish regular relations with the IPA, the only body authorized to recognize its training courses.

### Serbia

Two men contributed initially to opening Belgrade up to psychoanalysis. The first, Hugo Klajn (1894–1981), physician and psychiatrist, did his personal analysis in 1922 with Paul Schilder in Vienna. On his return to Belgrade his public lectures and translation of a considerable part of Freud's work met with an immediate success. He devoted himself mainly to theatre. As director of the Yugoslav dramatic theatre and Studio 122, his directing enriched the cultural domain. In 1955 he published *War Neuroses in Yugoslavs*.

Nikola Sugar (1897–1945) was the second of these founding fathers. He was analyzed in Berlin between 1922 and 1925 by Felix Boehm, then in Vienna between 1925 and 1927 by Paul Schilder. An associate member of the Vienna Psychoanalytic Society from 1925 to 1933, he was a full member from 1935 to 1938. When he returned to the city of Subotica (Vojvodina), he also became a member of Budapest Psychoanalytic Society. In 1938 he founded the first psychoanalytic association in Belgrade. Without having any formal character, it comprised nine members: six physicians, psychiatrists, and neurologists, and three philosophy professors. Meetings were held in the Belgrade Arts

Faculty and were soon forbidden under the regency of Prince Paul, who was close to Italy, Bulgaria, and Nazi Germany. Sugar was deported and died.

Two of Sugar's patients, Vladislav Klajn (1909–1984) and especially Vojin Matic (born 1911) were prolific in developing psychoanalytic activities. The IPA awarded an honorary diploma to Professor Vojin Matic at the San Francisco Congress in 1995. Vojin Matic was an assistant at the university neuropsychiatric clinic until 1952, before becoming a professor at the Arts Faculty until his retirement. In 1953 he founded the Medico-Psychopedagogical Center, the first of its kind in Yugoslavia. Ten years later the center was closed but continued to be active in the form of the Institute for Mental Health. In relation with the European Federation of Psychoanalysis, the Belgrade group organized the Seminar for Eastern Countries in 1990. The subject was "Transference and Counter-Transference." Protocols for psychoanalytic treatment were presented by S. Borovejki (Zagreb), V. Brzev (Belgrade), M. Cicek (Zagreb), I. Ivanovic and G. Marinkow (Belgrade). This seminar brought together more than eighty participants from Eastern Europe (Bulgaria, Hungary, Lithuania, Poland, Romania, Czechoslovakia, and Yugoslavia) and Western Europe (Germany, Spain, France, Great Britain, and Italy). Professors Nevenka Tadic, Ksenija Kondic-Belos, and Tamara Stajner-Popovic concentrated particularly on the development of psychoanalytic treatment for children and adolescents. The San Francisco Congress elected Stajner-Popovic and four of her colleagues direct members of the IPA. This election was the fruit of efforts by Hanna Groen-Prakken (of Holland) and John Kafka (of the United States) within the IPA. It opened the way for the constitution of a study group, then the formation of a provisional society, which could lead this group to recognition as a constituent society of the IPA.

MICHEL VINCENT

### **Bibliography**

Diatkine, Gilbert, Gibeault, Alain, Gibeault, Monique, and Vincent, Michel. (1993). La psychanalyse en Europe orientale. In *La Psychanalyse et l'Europe de 1993*, Paris: Presses Universitaires de France.

Nikolic, S. (1987). La psychiatrie en Yougoslavie. *Psychiatrie française*, 6, 41–51.

## **ZAVITZIANOS, GEORGES (1909–1995)**

Greek physician and psychoanalyst Georges Zavitzianos was born in Corfu, Greece, in 1909 and died in North Bethesda, Maryland on December 13, 1995.

Escaping from Turks who burned the village of Zavitzia in 1700, the Zavitzianos family settled in the Ionian island of Corfu, where they produced a succession of scientists, writers, and artists.

After secondary school in Greece, Zavitzianos studied medicine at Montpellier in France. Returning to his native country in 1934, he worked as a neuropsychiatrist with a psychoanalytic orientation; he had been briefly psychoanalyzed by the early French analyst, Edouard Pichon.

During the late 1940s Zavitzianos participated in the creation of the first Greek psychoanalytic group, founded with the help and guidance of Marie Bonaparte; in 1950 he was elected a member of the Société psychanalytique de Paris. However, soon thereafter he decided to emigrate to North America. He spent some time in Montreal and eventually settled in the United States. He took part in founding several psychoanalytic societies and institutes, and taught from 1950 to 1982. Seduced by her beautiful soprano voice, he married Sylvia Filyndras. He also underwent analysis with Leo Stone.

Zavitzianos's principal works concern female perversions (1982); problems of transvestism (1977); and what he called "homeovestism" (1972)—sexual enjoyment in wearing the clothes of one's own sex. He also wrote about problems of psychoanalytic technique (1967) and the patient-therapist relationship. Before he died, in a letter to Anna Potamianou, written on December 12, 1995, he expressed what he called his only regret—the fact that he had not been able to share his great analytic experience with his Greek colleagues.

ANNA POTAMIANOU

*See also:* Canada; Greece.

### **Bibliography**

Tzavaras, Athanase. (1996). Georges A. Zavitzianos: Corfu, 1909–Maryland/E.U, 1995. *Cahiers de psychiatrie*, 53, 10–13.

Zavitzianos, Georges. (1967). Problems of technique in the analysis of a juvenile delinquent: therapeutic alliance and transference neurosis. *International Journal of Psycho-Analysis*, 48, 439–447.



———. (1972). Homeovestism: perverse form of behavior involving wearing clothes of the same sex. *International Journal of Psycho-Analysis*, 53, 471–477.

———. (1977). The object in fetishism, homeovestism and transvestism. *International Journal of Psycho-Analysis*, 58, 487–495.

———. (1982). The perversion of fetishism in women. *Psychoanalytic Quarterly*, 51, 405–425.

## ZEITSCHRIFT FÜR PSYCHOANALYTISCHE PÄDAGOGIK

Founded in 1926 by Heinrich Meng, a German psychoanalyst, and Ernst Schneider, a Swiss educationist, the *Zeitschrift für Psychoanalytische Pädagogik* (*Review of Psychoanalytic Teaching*) was first published in Stuttgart, then in Vienna until 1937, with a view to disseminating psychoanalytic discoveries among educators and “inventing a new way of posing problems” (Balint, 1932).

Contributors to the *Review*, many of whom were women, were recruited from among psychoanalysts and teachers from Austria (August Aichhorn, Siegfried Bernfeld, Paul Federn, Anna Freud, Melanie Klein, Wilhelm Reich, and Richard and Edith Sterba), Germany (Erich Fromm, Frieda Fromm-Reichmann, Georg Groddeck, Karl Landauer, and Nelly Wolffheim), Switzerland (Hans Behn-Eschenburg, Oskar Pfister, Ernst Schneider, and Hans Zulliger), but also from Hungary (Alice Balint and Sándor Ferenczi), Britain (Dorothy Burlingham and Mary Chadwick), France (Marie Bonaparte and René Laforgue), as well as Sweden, Poland, and Russia (Sabina Spielrein). The *Review* contained two articles by Freud, who welcomed the initiative of the founders.

Although they initially nurtured the hope of being able to avoid the neuroses with the help of an appropriate education, the so-called psychoanalytic teachers progressively yielded to disenchantment, even pessimism. In 1936 Ruth Weiss presented a critical review of the questions remaining to be treated (Vol. 10). And in 1937, the *Review* (Vol. 11) published the papers presented at the Budapest symposium concerning the “revision” of psychoanalytic teaching: it analyzed the problems of the psychoanalytic educator (Dorothy Burlingham) and the shortcomings of a pedagogy that accorded insufficient importance to group phenomena (Hans Zulliger) and gave rise to misunderstandings (S. Bornstein-Windholz). And as

a result of events at the time and the departure of many psychoanalysts into exile, the *Review* ceased to appear in 1937.

Although there was relatively little response from the teaching profession, the provocation to think differently about the field of education and the subversive potential of the *Review* were important in the history of the relationship between teaching and psychoanalysis. Each issue, first monthly then quarterly, devoted considerable space to a review of psychological, psychoanalytic, and literary publications and reviews as well as statements and reports on psychoanalytic training and congresses.

As a forum for exchanging experiences and theorizing about a new teaching practice that was at odds with a repressive education, the *Review* saw itself as the spokesperson for an education that was “enlightened” by psychoanalysis. Its feature articles were illustrated by case studies and focused on the manifestations of infantile sexuality, the role of the emotions in learning, intellectual inhibitions and academic failure, the importance of transference phenomena, and the unconscious of the adult educator. It pleaded for another type of teacher training and for a collaboration between psychoanalysts and teachers. It provided a critical analysis of the different educational institutions as well as of the ideals of the new education movement.

The study of the phenomena of group psychology, the contradictions of the educational system, the psychic and social limits to the capacity to be educated, as well as political determinism oriented the movement for a psychoanalytically informed education and a sociological critique of education.

JEANNE MOLL

See also: Internationaler Psychoanalytischer Verlag; Meng, Heinrich; Schneider, Ernst.

### Bibliography

- Balint, Alice. (1953). *The psycho-analysis of the nursery*. London: Routledge & Kegan Paul. (Original work published 1932)
- Cifali, Mireille, and Moll, Jeanne. (1985). *Pédagogie et Psychanalyse*. Paris: Dunod.
- Moll, Jeanne. (1989). *La Pédagogie psychanalytique. Origine et histoire*. Paris: Dunod.

## ZENTRALBLATT FÜR PSYCHOANALYSE

In the wake of the *Jahrbuch für Psychoanalyse*, the psychoanalytic movement published its first monthly periodical, the *Zentralblatt für Psychoanalyse* (Central review of psychoanalysis) in 1911. For the first two years Freud was the editor and Wilhelm Stekel was the chief editor. Whereas the *Jahrbuch* addressed a specialist readership close to psychoanalysis and tended to reflect the specificity and specialization of clinical and theoretical psychoanalysis, the *Zentralblatt* had a more didactic mission. It tried on the one hand to afford a view of the rapidly growing wave of analytic literature and, on the other, to provide a forum for shorter works that were more accessible for the general public. Alongside more strictly medico-psychological articles, the *Zentralblatt* focused as well on interdisciplinary approaches involving history, literature, esthetics, teaching, and popular culture. The periodical addressed itself specifically to a lay readership both as the final consumer of psychoanalytic progress and as the author, thus becoming a witness to the “progress” of psychoanalytic knowledge.

The new periodical was introduced with a contribution by Freud, “The Future Prospects of Psychoanalytic Therapy” (1910d). A considerable amount of space was reserved for brief observations in the form of examples, for the interpretation of dreams, parapraxes, and symptoms resulting from the “psychoanalysis workshop.” In addition to providing a large space for reviews, intended as a guide to the mass of psychoanalytic publications, the *Zentralblatt* also provided the earliest information on psychoanalytic associations and their calendars of activities, beginning with the report on the first private psychoanalytic meeting held in Salzburg on April, 27, 1908.

After 1912 the *Zentralblatt* also contained the “correspondence sheet” (*Korrespondenzblatt*), previously reserved exclusively for members of the International Psychoanalytical Association (IPA), and thus became its official organ. This official role provoked a conflict in 1912 between the association and the editor, Wilhelm Stekel: Freud withdrew as editor in November 1912 and Stekel, having disagreed with the master concerning the choice of Viktor Tausk to replace him, took single-handed control of the position. That same year saw the founding of a new periodical, *Imago*, which acted as an alternative spokesperson for psychoanalysis.

As a result of this tension the IPA suspended its official collaboration with the *Zentralblatt* and in 1913 it

founded its own publication, the *Internationale Zeitschrift für Psychoanalyse*, which resumed publication of the “correspondence sheets.” Following this new configuration of the market for psychoanalytic publications, the *Zentralblatt* suspended its activity in 1914.

LYDIA MARINELLI

*See also:* Abraham, Karl; Adler, Alfred; *Internationale Zeitschrift für (ärztliche) Psychoanalyse*; *Jahrbuch der Psychoanalyse*; Stekel, Wilhelm.

### Source Citation

*Zentralblatt für Psychoanalyse. Medizinische Monatsschrift für Seelenkunde*, Wiesbaden, J. F. Bergmann, 1910/11–1914 (Central review of psychoanalysis, medical monthly for psychology).

### Bibliography

Freud, Sigmund, and Jones, Ernest. (1993 [1908–39]). *The complete correspondence of Sigmund Freud and Ernest Jones, 1908–1939*, R.A. Paskauskas (Ed.), London: The Belknap Press of Harvard University Press.

Stekel, Wilhelm. (1950). *The autobiography of Wilhelm Stekel. The life story of a pioneer psychoanalyst*. New York: Liveright.

## ZETZEL-ROSENBERG, ELIZABETH (1907–1970)

Elizabeth Zetzel-Rosenberg, psychoanalyst and physician, was born March 17, 1907, in New York and died November 22, 1970, in Scarsdale, New York. Her father, James N. Rosenberg, was a distinguished jurist and philanthropist, who led a United States committee for the passage of the Genocide Convention at the United Nations after World War II. After graduating from Smith College, Zetzel pursued her medical education at the University of London. She began her analytic training in the 1930s at the British Psychoanalytic Society where her analyst was Ernest Jones.

In a short memoir describing the years between 1936 and 1938, Zetzel (1969) recalled with pleasure her exposure to the work of Melanie Klein and her followers, Joan Riviere and Susan Isaacs. She credits Donald Winnicott, however, with most influencing her subsequent work because he was “fully alive to the

importance of the real mother-child relationship ... My first awareness of the importance of early object relations was attributable to my opportunity to work in his Clinic at Paddington Green Hospital.”

Zetzel returned to the United States in 1949 and became a leading member of the Boston Psychoanalytic Society, where she was an influential training analyst and teacher; she was also secretary of the International Psychoanalytic Association under the presidency of Maxwell Gitelson from 1961 to 1965 (Rangell, 1971). Zetzel was a prolific writer and her collected papers (1970) include contributions to psychoanalytic technique—her name is practically synonymous with the term “therapeutic alliance”—and to the psychodynamics of hysteria and depression as delineated in her seminal papers “On the Incapacity to Bear Depression” and “The So-Called Good Hysteric.” But equally important as her original contributions to the psychoanalytic literature was her sympathetic interest in the work of Melanie Klein. In an astute and generous obituary written after Klein’s death, Zetzel (1961) decried the fact that many contemporary analysts still remained unfamiliar with Klein’s work. At the same time, Zetzel was deeply skeptical of the theoretical reconstructions that Klein posited in her writings. She also chided Klein and her followers for failing to acknowledge the work of other analysts, notably Anna Freud, Willi Hoffer, Rene Spitz, Phyllis Greenacre, and Ernst Kris, whose findings on early psychic development were convergent with their discoveries.

Zetzel’s advocacy of Klein’s work had significant implications for the development of psychoanalytic theory in the United States. Conventionally, psychoanalytic theory in America in the 1950s is portrayed as dominated by the variant of theory called ego psychology. But Zetzel’s writings on Klein and her followers, and her extended contacts with other analysts interested in preoedipal development, notably Edith Jacobson and Phyllis Greenacre, suggest a more fluid and complex state of affairs. In other words, among a group of influential psychoanalytic thinkers, there was a sophisticated awareness of Klein’s work and a recognition that her clinical discoveries should be considered in their own work.

NELLIE L. THOMPSON

### **Bibliography**

Rangell, Leo. (1971). Elizabeth R. Zetzel. *International Journal of Psycho-Analysis*, 52, 229–231.

Thompson, Nellie. (2001). American women psychoanalysts 1911–1941. *Annual of Psychoanalysis*, 29, 161–177.

Zetzel, Elizabeth. (1961). Melanie Klein 1882–1960. *The Psychoanalytic Quarterly*, 30, 420–425.

———. (1969). 96 Gloucester Place: Some personal recollections. *International Journal of Psycho-Analysis*, 50, 717–719.

———. (1970). *The capacity for emotional growth*. New York: International Universities Press.

---

### **ZULLIGER, HANS (1893–1965)**

Hans Zulliger, a psychoanalytically oriented Swiss teacher and child psychoanalyst, was born on February 21, 1893, near Biel, Switzerland, and died in Illigen, Berne Canton, in 1965. Coming from a modest background, he was a student at the teachers school in Hofwil-Berne. The principal of the school, Ernst Schneider, taught psychology and psychoanalysis. All his life Zulliger remained a primary school teacher in Illigen-Bolligen, near Berne, continuing to teach working class, rural, and underprivileged children until 1959.

From his first early encounter with psychoanalysis, Zulliger was passionately enthusiastic about the new theory of the unconscious. He read Freud and Alfred Adler, contacted the pastor Oskar Pfister, who became his analyst, and conducted his own research with his pupils. His observations and reflections on school failure, anxiety, and other symptoms, and on the need for and difficulties of sexual education, led to a publication in 1921, a work that was favorably received by the Swiss psychoanalytic world. Freud encouraged the young author, who visited the master twice. His subversively titled *La psychanalyse à l'école* (Psychoanalysis at school) appeared in France in 1930. As a member of the Swiss Psychoanalytic Society, Zulliger also played a part in elaborating projective tests.

In addition to working as a schoolteacher, he also worked as a child psychotherapist, psychologist, and writer (in German and in dialect). He contributed many articles to the *Zeitschrift für psychoanalytische Pädagogik*, which he coedited after 1932, and he also published in other Swiss teaching journals. In 1928 the *Revue française de psychanalyse* published one of his articles, “La psychanalyse et les écoles nouvelles” (Psychoanalysis and the new schools).

Zulliger was without doubt the most popular representative of the psychoanalytic teaching propounded by the *Zeitschrift für psychoanalytische Pädagogik*. He

excelled at recounting his practice in a lively style with colorful language. His many case studies illustrate his skillful mastery of the art of dialog and his profound understanding of children, both as individuals and in groups, as well as his insight into the games they play. He had a sense of the therapeutic power of the educational milieu, where the schoolteacher mediates between children's instinctual egos and cultural values. After World War II, Zulliger's lectures in Switzerland and Germany contributed to reigniting the movement for psychoanalytic teaching, of which he was a remarkable pioneer.

JEANNE MOLL

*See also:* Schweizerische Ärztgesellschaft für Psychoanalyse; Switzerland (German-speaking); *Zeitschrift für psychoanalytische Pädagogik*.

### Bibliography

Cifali, Mireille, and Moll, Jeanne (Eds.). (1985). *Pédagogie et psychanalyse*. Paris: Dunod.

Zulliger, Hans. (1928). La psychanalyse et les écoles nouvelles (L. Leuzinger, Trans.). *Revue française de psychanalyse*, 2 (4), 711–720.

———. (1930). *Psychanalyse à l'école* (Jean-Pierre Peyraube, Trans.). Paris: Flammarion.

———. (1934). Prophetic dreams. *International Journal of Psycho-Analysis*, 15 (2–3), 191–208.

———. (1950). Psycho-analysis and the form-interpretation test. *International Journal of Psycho-Analysis*, 31 (1–2), 152–155.

---

## ZWEIG, ARNOLD (1887–1968)

Born to a Jewish family in Glogau, Silesia, on November 10, 1887, novelist and author Arnold Zweig died in East Berlin, almost completely blind, on November 26, 1968. At his death Zweig was the most celebrated author in the German Democratic Republic (East Germany).

Zweig was unrelated to the Austrian writer Stefan Zweig, but both men were important to Sigmund Freud, albeit in different ways. According to Ernest Jones: “Freud’s attitude toward the two men was indicated by his mode of address. Stefan was *Lieber Herr Doktor*, Arnold was *Lieber Meister Arnold*” (1957, p. 133).

Between 1927 and 1939 Zweig and Sigmund Freud conducted an exceptionally important correspondence. When it was published in 1968, Freud’s son Ernst and Arnold’s son Adam decided to withhold twenty-five letters as being too personal or of insufficient scientific value, creating an impression that they wished to conceal something in their fathers’ private lives.

Originally a saddler by trade, Adolf Zweig became a supplier to the Prussian army before anti-Semitic regulations forced him to return to his former profession, an incident that seems to have had a powerful impact on his son. Zweig was a brilliant student who matriculated at various European universities before being conscripted during World War I, a painful experience that undoubtedly played a role in his later antimilitarism.

Zweig began publishing fiction in 1911, and was a profound admirer both of Thomas Mann and of the nineteenth-century realists. Publication of *The Case of Sergeant Grischa* (1927) made him known to a wide audience and brought him to the attention of Freud.

After the National Socialists came to power in Germany, Zweig emigrated to Palestine in 1933 and lived for some years in Haifa. He traveled widely, and a trip to New York in 1939 enabled him to meet other well-known German émigrés. Zweig had long been interested in Zionism and socialism, but by the time Israel became a state he was both disillusioned and impoverished. He returned to East Germany in 1948, and was soon elected a parliament deputy in the new socialist republic. Zweig also succeeded Heinrich Mann as president of the German Academy of Arts. Henceforth, Zweig was a government-sponsored author and member of the Communist Party. For his efforts to legitimize East German literature, he was awarded the Lenin Peace Prize.

Zweig’s literary work features a severe critique of militarism and lively political and social convictions. These traits are also characteristic of his correspondence with Freud; their subjects range from incest and homosexuality to a wide variety of reflections on political, historical, and poetical issues.

In one of the most famous letters in their correspondence (May 11, 1934), Freud’s comments about Zweig’s plan for a book on Friedrich Nietzsche served as an opening for his own ideas on the problems of psychological and psychopathological biography. He wrote: “I cannot say whether these are my true reasons against your plan. Perhaps they have something to do

with the way in which you compare me to him. In my youth [Nietzsche] signified a nobility to which I could not attain” (Jones, 1957, p. 460). This passage probably reflects the character of transference love that more or less pervades the Freud-Zweig relationship. Zweig also alludes briefly in the correspondence to the difficulties he encountered in his own analysis in Berlin, by which he hoped to treat severe depression and anxiety.

The year Freud began writing *Moses and Monotheism*, he reported on the work and its difficulties in a letter to Zweig (September 30, 1934). In discussing the project with Max Eitington, Zweig remarked that he had advised Freud to publish his book in Palestine. Judaism was an important topic for both men and the subject of many of their letters. In one letter (May, 31 1936) Zweig reports on an archaeological discovery that might confirm Freud’s theory about the origins of the man Moses. In 1937, Freud, who thought that his “hereditary claim to life would run out in November,” (Jones, 1957, p. 213) asked Zweig, who was considering a visit to Europe, not to postpone it any longer.

In 1938, Zweig made a final attempt to intervene on Freud’s behalf in favor of his being awarded the Nobel Prize. Freud held out little hope for this, considering opposition to psychoanalysis and his reputation in the eyes of the Nazis. He wrote Zweig on June 28, 1938: “[I]t can hardly be expected that the official circles could bring themselves to make such a provocative challenge to Nazi Germany as bestowing the honor on me would be.” (Jones, 1957, p. 234)

Arnold Zweig was one of many celebrated literary figures whose friendship Freud cultivated. Their common interests in Judaism, pacifism, and such historical figures as Napoleon, Nietzsche, and Moses brought them particularly close.

BERNARD GOLSE

See also: Autobiography; Literature and psychoanalysis.

### Bibliography

Freud, Sigmund. (1968a [1927–39]). *The letters of Sigmund Freud and Arnold Zweig* (Ernst L. Freud, Ed.; Professor and Mrs. W. D. Robson-Scott, Trans.). London: Hogarth Press, 1970.

Jones, Ernest. (1957). *Life and work of Sigmund Freud* (Vol. 3). New York: Basic Books.

### Further Reading

Mijolla, Alain de. (1993). Freud, biography, his autobiography, and his biographers. *Psychoanalysis and History*, 1 (1), 4–27.

## ZWEIG, STEFAN (1881–1942)

Stefan Zweig, an Austrian writer, was born in Vienna on November 28, 1881, and committed suicide in Petrópolis, Brazil, on February 22, 1942. From a wealthy middle-class Jewish family, Zweig enjoyed a privileged childhood. He grew up in an open-minded and multilingual home—a background that undoubtedly played a role in his subsequent commitment to humanist and supranationalist thought. While young he became a celebrated author, traveled widely, and developed friendships with a host of literary figures, among them the French novelist and playwright Romain Rolland and the Belgian poet Emile Verhaeren, whose work he translated. Zweig’s best-known works include the novels *Amok* (1922), *Beware of Pity* (1938), and *Conflicts* (1926), a collection that includes the novella *Twenty-four Hours in the Life of a Woman*. His autobiography, *The World of Yesterday*, appeared posthumously in 1943.

Zweig’s work, at once distinguished by its richness and diversity, includes poetry, plays, essays, short stories, novels, and biographies. He was one of the most prolific authors of his time and played a major role in creating a rapprochement between French and German literature.

In *Mental Healers* (1932), Zweig not only discussed Mary Baker Eddy, the founder of Christian Science, and Franz Mesmer’s animal magnetism; he also devoted an essay to Freud, for whom he expressed profound admiration and gratitude. In 1908 Zweig and Freud began a long correspondence that continued until the latter’s death in London in 1939. Zweig delivered Freud’s funeral oration.

In Zweig’s letter to Freud of September 8, 1926, he wrote, “For me, psychology is today *the* great passion of my life (as you will understand better than anyone else). . . . You still play the decisive role in the invisible struggle for the soul. You alone are always the one to explain to us, in a creative way, the mechanism of the spiritual. More than ever we need you and your activity.” Later, in his letter of October 21, 1932, he wrote, “Everything I write is marked by your influence and

you understand, perhaps, that the courage to tell the truth, probably the essential thing in my books, comes from you: You have served as a model for an entire generation.” Zweig’s interest in psychoanalysis found expression in his writings. In both his novels and fictionalized biographies, the main characters are presented in “case histories,” made more intriguing by a nostalgic evocation of a society condemned by history.

Freud recognized in Zweig an interest in, and aptitude for, psychological analysis. Although they argued several times—over errors Zweig made in translating Freud’s work and concerning Zweig’s appreciation of such detractors as Charles E. Maylan—Freud valued Zweig’s friendship until the end of his life.

After the Nazis prohibited and destroyed his books in 1933, Zweig emigrated to London in 1934. Together with Salvador Dalí, he visited Freud on July 19, 1938. Since Freud was near death, Zweig did not dare to show him the two sketches that Dalí had made of him. In his last letter to Freud, dated September, 14, 1939, nine days before Freud’s death, he wrote, “I hope that you are suffering only from the era, as we all do, and not also from physical pain. We must stand firm now—it would be absurd to die without having first seen the criminals sent to hell.”

After obtaining British citizenship in 1940, Zweig settled in Petrópolis, Brazil, in 1941. He became a symbol of the anguish of exile and the refusal to accept Hitler’s early triumphs. Despite this, in profound despair after Nazi victories early in the war,

he committed suicide together with his second wife, Lotte Altmann.

In his final declaration Zweig wrote, “It seems to me therefore better to put an end, in good time and without humiliation, to a life in which intellectual work has always been an unmixed joy and personal freedom earth’s most precious possession.” “I greet all my friends! May they live to see the dawn after the long night is over! I, all too impatient, am going on alone” (Allday, 1972, p. 238).

CHRISTINE DE KERCHOVE

*See also:* “Dostoyevsky and parricide”; Goethe Prize; Literature and psychoanalysis.

### **Bibliography**

- Allday, Elizabeth. (1972). *Stefan Zweig: A critical biography*. Chicago: J. Philip O’Hara.
- Freud, Sigmund, and Zweig, Stefan. (1987). *Correspondence*. Paris: Rivages Poche.
- Niémetz, Serge. (1996). *Stefan Zweig: Le voyageur et ses mondes*. Paris: Belfond.
- Zweig, Stefan. (1932). *Mental healers: Franz Anton Mesmer, Mary Baker Eddy, Sigmund Freud*. New York: Viking Press.

### **Further Reading**

- Mijolla, Alain de. (1998). Freud, biography, his autobiography, and his biographers. *Psychoanalysis and History*, 1 (1), 4–27.



# FREUDIAN BIBLIOGRAPHY

## ΕΒΕΥΔΙΑΝ ΒΙΒΛΙΟΓΡΑΦΙΑ

Only those references to Freud that have been specifically cited in one form or another in the body of the dictionary itself have been included in this list of his works, which does not pretend to be exhaustive (hence the fact that the series of references using a, b, c, etc. will not all be found here). The full list, upon which this one is based, is in the *Freud-Bibliographie mit Werkkonkordanz* assembled by Ingeborg Meyer-Palmedo and Gerhard Fichtner, (S. Fischer Verlag: 1989). Each entry in this list references the text's first publication date, its publication date in the *Gesammelte Werke* (GW), and its translation in the Standard Edition of the Complete Psychological Works of Sigmund Freud (SE).

- Freud, Sigmund. (1888–89a). Vorrede des Übersetzters. In H. Bernheim: *Die Suggestion und ihre Heilwirkung, Teil I*, Leipzig-Wien, p. III–XII; Tübingen: Diskord, 1985; *Preface to the translation of Bernheim's Suggestion*. SE, 1: 71–85.
- . (1889a). Rezension von Forel Auguste: 'Der Hypnotismus', Stuttgart 1889. *Wiener medizinische Wochenschrift*, XXXIX, p. 1097–1100, 1892–1896; GW, Nachtr., p. 125–139; Review of August Forel's "Hypnotism." SE, 1: 89–102.
- . (1890a). Psychische Behandlung (Seelenbehandlung). In R. Kossman and J. Weiss (Eds.), *Die Gesundheit: Ihre Erhaltung, ihre Störungen, ihre Wiederherstellung* (Vol. I, pp. 368–384). Stuttgart, Berlin, Leipzig; GW, V, p. 287–315; Psychical (or mental) treatment. SE, 7: 281–302.
- . (with Oscar Rie [1891a]). *Klinische Studie über die halbseitige Cerebrallähmung der Kinder, Heft III der Beiträge zur Kinderheilkunde*. Wien: Kassowitz.
- . (1891b). *Zur Auffassung der Aphasien*. Wien; *On aphasia; a critical study* (E. Stengel, Trans.). New York: International Universities Press, 1953.
- . (1891c). Kinderlähmung, Lähmung. In A. Villaret (Ed.), *Handwörterbuch der gesamten Medizin* (Vol. 2, p. 91–93, 169–171). Stuttgart.
- . (1891d). Hypnose. In A. Bum (Ed.), *Therapeutisches Lexikon* (pp. 724–734). Wien; GW, Nachtr., p. 141–150; SE, I, p. 105–114. *Hypnosis*. SE, 1: 103–114.
- . (1892–93a). Ein Fall von hypnotischer Heilung nebst Bemerkungen über die Entstehung hysterischer Symptome durch den "Gegenwillen." *Zeitschrift Hypnotische*, I, 102–107, 123–129; GW, I, p. 3–17; A case of successful treatment by hypnotism. SE, 1: 115–128.
- . (1892–94a). *Traduction. Introduction et notes de J.-M. Charcot: Leçons du mardi à la Salpêtrière (1887–1888)*. Paris, 1888; Poliklinische Vorträge, Vol. I–II, Leipzig-Wien: 1895; GW, Nachtr., p. 153–157, 158–164 "Preface and footnotes to the translation of Charcot's Tuesday Lectures". SE, 1: 129–144.
- . (1892a). *Neue Studien über Hypnotismus, Suggestion und Psychotherapie, trad. de H. Bernheim: Hypnotisme, suggestion, psychothérapie, études nouvelles*. Leipzig-Wien; *Bernheim's New studies in hypnotism (Richard S. Sandor, Trans.)*. New York: International Universities Press, 1980.
- . (1893c). Quelques considérations pour une étude comparative des paralysies motrices organiques et hystériques. *Archives of Neurology*, XXVI, 29–43; GW, I, p. 39–55; Some points for a comparative study of organic and hysterical motor paralyses. SE, 1: 155–172.
- . (1893e). *Infantile cerebral paralysis* (Lester A. Russin, Trans.). Coral Gables, FL: University of Miami Press, 1968.
- . (1893f). Charcot. *Wiener medizinische Wochenschrift*, XLIII, 1513–1520; GW, I, p. 21–35; Charcot. SE, 3: 7–23.
- . (1893g). Über ein Symptom, das häufig die Enuresis nocturna der Kinder begleitet, *Neurologisches Zeitblatt*, XII, p. 735–737.



- . (1894a). Die Abwehr-Neuropsychosen. Versuch einer psychologischen Theorie der erworbenen Hysterie, vieler Phobien und Zwangsvorstellungen und gewisser halluzinatorischer Psychosen, *Neurologisches Zeitblatt*, XIII, 362–364, 402–409; GW, I, p. 59–74; The neuro-psychoses of defence. *SE*, 3: 41–61.
- . (1895b [1894]). Über die Berechtigung, von der Neurasthenie einen bestimmten Symptomenkomplex als Angst-Neurose abzutrennen. *Neurologisches Zeitblatt*, XIV, 50–66; GW, I, p. 315–342; On the grounds for detaching a particular syndrome from neurasthenia under the description anxiety neurosis. *SE*, 3: 85–115.
- . (1895c [1894]). Obsessions et phobies; leur mécanisme psychique et leur étiologie. *Revue neurologique*, III, 33–38; GW, I, p. 345–353; Obsessions and phobias: their psychical mechanism and their aetiology. *SE*, 3: 69–82.
- . (1895f). Zur Kritik der Angstneurose. *Wiener klinische Rundschau*, IX, 417–419, 435–437, 451; GW, I, p. 357–376; A reply to criticisms of my paper on anxiety neurosis. *SE*, 3: 118–139.
- . (1896a). L'hérédité et l'étiologie des névroses. *Revue neurologique*, IV, 161–169; GW, I, p. 407–422; Heredity and the aetiology of the neuroses. *SE*, 3: 141–156.
- . (1896b). Weitere Bemerkungen über die Abwehr-Neuropsychosen. *Neurologisches Zeitblatt*, XV, 434–448; GW, I, p. 379–403; Further remarks on the neuro-psychoses of defence. *SE*, 3: 157–185.
- . (1896c). Zur Ätiologie der Hysterie. *Wiener klinische Rundschau*, X, 379–381, 395–397, 413–415, 432, 450–452; GW, I, p. 425–459; The aetiology of hysteria. *SE*, 3: 186–221.
- . (1897a). Die infantile Cerebrallähmung. In H. Nothnagel (Ed.), *Spezielle Pathologie und Therapie* (Vol. IX). Wien.
- . (1898a). Die Sexualität in der Ätiologie der Neurosen. *Wiener klinische Rundschau*, XII, 21, 55–57, 70–72, 103–105; GW, I, p. 491–516; Sexuality in the aetiology of the neuroses. *SE*, 3: 259–285.
- . (1898b). Zum psychischen Mechanismus der Vergesslichkeit. *Monatsschrift für Psychiatrie und Neurologie*, IV, 436–443; GW, I, p. 519–527; The psychical mechanism of forgetfulness. *SE*, 3: 287–297.
- . (1899a). Über Deckerinnerungen. *Monatsschrift für Psychiatrie und Neurologie*, VI, 215–230; GW, I, p. 531–554; Screen memories. *SE*, 3: 299–322.
- . (1900a). *Die Traumdeutung*. Leipzig-Wien: F. Deuticke; GW, II-III; The interpretation of dreams. Part I. *SE*, 4: 1–338. The interpretation of dreams. Part II. *SE*, 5: 339–625.
- . (1901a). Über den Traum. In L. Löwenfeld, H. Kurella (Eds.), *Grenzfragen des Nerven- und Seelenlebens*. Wiesbaden: J.-F. Bergmann, p. 307–344; GW, II–III, p. 643–700; On dreams. *SE*, 5: 629–685.
- . (1901b). Zur Psychopathologie des Alltagslebens. Über Vergessen, Versprechen, Vergreifen, Aberglaube und Irrtum. *Monatsschrift für Psychiatrie und Neurologie*, X (1–2), 1–32, 95–143; *Zur Psychopathologie des Alltagslebens*. Berlin, Karger, 1904; GW, IV; The psychopathology of everyday life. *SE*, 6.
- . (1904a [1903]). Die Freudsche psychoanalytische Methode. In L. Löwenfeld (Ed.), *Die Psychischen Zwangsercheinungen* (pp. 545–551). Wiesbaden; GW, V, p. 3–10; Freud's psycho-analytic procedure. *SE*, 7: 247–254.
- . (1905a [1904]). Über Psychotherapie. *Wiener medizinische Presse*, XLVI, 9–16; GW, V, p. 13–26; On psychotherapy. *SE*, 7: 255–268.
- . (1905c). *Der Witz und seine Beziehung zum Unbewussten*. Leipzig-Wien: F. Deuticke; GW, VI; Jokes and their relation to the unconscious. *SE*, 8: 1–236.
- . (1905d). *Drei Abhandlungen zur Sexualtheorie*. Leipzig-Wien: F. Deuticke; GW, V, p. 27, 33–145; Three essays on the theory of sexuality. *SE*, 7: 123–243.
- . (1905e [1901]). Bruchstück einer Hysterie-Analyse. *Monatsschrift für Psychiatrie und Neurologie*, XVIII, 285–310, 408–467; GW, V, p. 161–286; Fragment of an analysis of a case of Hysteria. *SE*, 7: 1–122.
- . (1906a [1905]). Meine Ansichten über die Rolle der Sexualität in der Ätiologie der Neurosen. In L. Löwenfeld (Ed.), *Sexualleben und Nervenleiden*. Wiesbaden: J.-F. Bergmann, p. 313–322; GW, V, p. 149–159; My views on the part played by sexuality in the aetiology of the neuroses. *SE*, 7: 269–279.
- . (1906c). Tatbestandsdiagnostik und Psychoanalyse. *Archiv Kriminal Anthropologie*, XXVI, 1–10; GW, VII, p. 3–15; Psycho-analysis and the establishment of facts in legal proceedings. *SE*, 9: 97–114.
- . (1907a [1906]). *Der Wahn und die Träume in W. Jensens Gradiva*. Leipzig-Wien: Hugo Heller; GW, VII, p. 29–122; Delusions and dreams in Jensen's *Gradiva*. *SE*, 9: 1–95.
- . (1907b). Zwangshandlungen und Religionsbungen. *Zeitschrift für Religion*, I, 4–12; GW, VII, p. 129–139; Obsessive actions and religious practices. *SE*, 9: 115–127.
- . (1907c). Zur sexuellen Aufklärung der Kinder (Offener Brief an Dr M. Fürst). *Soz. Med. Hyg.*, II,

- 360–367; *GW*, VII, p. 19–27; The sexual enlightenment of children. *SE*, 9: 129–139.
- . (1908a). Hysterische Phantasien und ihre Beziehung zur Bisexualität. *Zeitschrift für Sexualwissenschaft*, I, 27–34; *GW*, VII, p. 191–199; Hysterical phantasies and their relation to bisexuality. *SE*, 9: 156–166.
- . (1908b). Charakter und Analerotik. *Psychiatrie und Neurologie Wochenschrift*, IX, 465–467; *GW*, VII, p. 203–209; Character and anal erotism. *SE*, 9: 167–175.
- . (1908c). Über infantile Sexualtheorien. *Sexual-Probleme*, IV, 763–779; *GW*, VII, p. 171–188; On the sexual theories of children. *SE*, 9: 205–226
- . (1908d). Die kulturelle Sexualmoral und die moderne Nervosität. *Sexual-Probleme*, IV, 107–129; *GW*, VII, p. 143–167; 'Civilized' sexual morality and modern nervous illness. *SE*, 9: 177–204.
- . (1908e [1907]). Der Dichter und das Phantasieren. *Neue Revue*, I, 716–724; *GW*, VII, p. 213–223; Creative writers and day-dreaming. *SE*, 9: 141–153.
- . (1909a [1908]). Allgemeines über den hysterischen Anfall. *Zeitschrift Psychother. med. Psychol.*, I, p. 10–14; *GW*, VII, p. 235–240; Some general remarks on hysterical attacks. *SE*, 9: 227–234.
- . (1909b). Analyse der Phobie eines fünfjährigen Knaben (Der kleine Hans), *Jahrbuch für psychoanalytische und psychopathologie Forschungen*, I, 1–109; *GW*, VII, p. 241–377; Analysis of a phobia in a five-year-old boy. *SE*, 10: 1–149.
- . (1909c [1908]). Der Familienroman der Neurotiker. In Otto Rank, *Der Mythos von der Geburt des Helden. Versuch einer psychologischen Mythendeutung* (pp. 64–68). Leipzig-Wien: F. Deuticke; *GW*, VII, p. 227–231; Family romances. *SE*, 9: 235–241.
- . (1909d). Bemerkungen über einen Fall von Zwangsneurose ("Der Rattenmann"), *Jahrbuch für psychoanalytische und psychopathologie Forschungen*, I, 357–421; *GW*, VII, p. 379–463; Notes upon a case of obsessional neurosis. *SE*, 10: 151–318.
- . (1910a [1909]). Über Psychoanalyse. *Fünf Vorlesungen, gehalten zur 20jährigen Gründungsfeier der Clark University in Worcester/Mass., September 1909*. Leipzig-Wien: F. Deuticke; *GW*, VIII, p. 1–60; Five lectures on psycho-analysis. *SE*, 11: 7–55.
- . (1910c). *Eine Kindheitserinnerung des Leonardo da Vinci*. Leipzig-Wien: F. Deuticke; *GW*, VIII, p. 127–211; Leonardo da Vinci and a memory of his childhood. *SE*, 11: 57–137.
- . (1910d). Die zukünftigen Chancen der psychoanalytischen Therapie. *Zentralblatt für Psychoanalyse*, I, 1–9; *GW*, VIII, p. 104–115; The future prospects of psycho-analytic therapy. *SE*, 11: 139–151.
- . (1910e). Über den Gegensinn der Urworte. *Jahrbuch für psychoanalytische und psychopathologie Forschungen*, II, 179–184; *GW*, VIII, p. 214–221; The antithetical meaning of primal words. *SE*, 11: 153–161.
- . (1910h). Über einen besonderen Typus der Objektwahl beim Manne (Beiträge zur Psychologie des Liebeslebens, I). *Jahrbuch für psychoanalytische und psychopathologie Forschungen*, II, 389–397; *GW*, VIII, p. 66–77; A special type of choice of object made by men. *SE*, 11: 163–175.
- . (1910i). Die psychogene Sehstörung in psychoanalytischer Auffassung. *Ärztliche Fortbildung*, IX, 42–44; *GW*, VIII, p. 94–102; The psycho-analytic view of psychogenic disturbance of vision. *SE*, 11: 209–218.
- . (1910k). Überwilde Psychoanalyse, *Zentralblatt für Psychoanalyse*, I, 91–95; *GW*, VIII, p. 118–125; 'Wild' psycho-analysis. *SE*, 11: 219–227.
- . (1911b). Formulierungen über die zwei Prinzipien des psychischen Geschehens. *Jahrbuch für psychoanalytische und psychopathologie Forschungen*, III, 1–8; *GW*, VIII, p. 230–238; Formulations on the two principles of mental functioning. *SE*, 12: 213–226.
- . (1911c [1910]). Psychoanalytische Bemerkungen über einen autobiographisch beschriebenen Fall von Paranoia (Dementia paranoides) [Schreber]. *Jahrbuch für psychoanalytische und psychopathologie Forschungen*, III, 9–69; *GW*, VIII, p. 239–316; Psychoanalytic notes on an autobiographical account of a case of paranoia (dementia paranoides). *SE*, 12: 1–82.
- . (1911d). Die Bedeutung der Vokalfolge. *Zentralblatt für Psychoanalyse*, II, 105; *GW*, VIII, p. 348; The significance of sequences of vowels. *SE*, 12: 341–341.
- . (1911e). Die Handhabung der Traumdeutung in der Psychoanalyse. *Zentralblatt für Psychoanalyse*, II, 109–113; *GW*, VIII, p. 350–357; The handling of dream-interpretation in psycho-analysis. *SE*, 12: 89–96.
- . (1911f). Gross ist die Diana der Epheser. *Zentralblatt für Psychoanalyse*, II, 158; *GW*, VIII, p. 360; "Great is Diana of the Ephesians." *SE*, 12: 342–344.
- . (1912b). Zur Dynamik der Übertragung. *Zentralblatt für Psychoanalyse*, II, 167–173; *GW*, VIII, p. 364–374; The dynamics of transference. *SE*, 12: 97–108.
- . (1912c). Über neurotische Erkrankungstypen. *Zentralblatt für Psychoanalyse*, II, 297–302; *GW*, VIII, p. 322–330; Types of onset of neurosis. *SE*, 12: 227–238.

- . (1912d). Über die allgemeinste Erniedrigung des Liebeslebens (Beiträge zur Psychologie des Liebeslebens, II). *Jahrbuch für psychoanalytische und psychopathologische Forschungen*, IV, 40–50; *GW*, VIII, p. 78–91; On the universal tendency to debasement in the sphere of love. *SE*, 11: 177–190.
- . (1912e). Ratschläge für den Arzt bei der psychoanalytischen Behandlung. *Zentralblatt für Psychoanalyse*, II, 483–489; *GW*, VIII, p. 376–387; Recommendations to physicians practising psycho-analysis. *SE*, 12: 109–120.
- . (1912f). Beiträge zur Onanie-Diskussion: Zur Einleitung und Schlusswort (XIV). In *Die Onanie. Vierzehn Beiträge zu einer Diskussion der Wiener Psychoanalytischen Vereinigung (Diskussionen der Wiener psychoanalytischen Vereinigung, Heft II)* (p. III, 132–140). Wiesbaden: J.-F. Bergmann; *GW*, VIII, p. 332–345; Contributions to a discussion on masturbation. *SE*, 12: 239–254.
- . (1912g). A note on the unconscious in psycho-analysis. *Proceedings of the Society for Psychical Research*, XXVI (66), 1913, 312–318; Einige Bemerkungen über den Begriff des Unbewussten in der Psychoanalyse. *Internationale Zeitschrift für ärztliche Psychoanalyse*, I, 1913, 117–123; *GW*, VIII, p. 430–439; A note on the unconscious in psycho-analysis. *SE*, 12: 255–266.
- . (1912–13a). *Totem und Tabu*. Leipzig-Wien: Hugo Heller; *GW*, IX; Totem and taboo. *SE*, 13: 1–161.
- . (1913a). Ein Traum als Beweismittel. *Internationale Zeitschrift für ärztliche Psychoanalyse*, I, 73–78; *GW*, X, p. 12–22; An evidential dream. *SE*, 12: 267–277.
- . (1913c). Zur Einleitung der Behandlung (Weitere Ratschläge zur Technik der Psychoanalyse). *Internationale Zeitschrift für ärztliche Psychoanalyse*, I, 1–10, 139–146; *GW*, VIII, p. 454–478; On beginning the treatment (Further recommendations on technique of psycho-analysis I). *SE*, 12: 121–144.
- . (1913f). Das Motiv der Kästchenwahl. *Imago*, II, 257–266; *GW*, X, p. 24–37; The theme of the three caskets. *SE*, 12: 289–301.
- . (1913g). Zwei Kinderlügen. *Internationale Zeitschrift für ärztliche Psychoanalyse*, I, 359–362; *GW*, VIII, p. 422–427; Two lies told by children. *SE*, 12: 303–309.
- . (1913i). Die Disposition zur Zwangneurose. Ein Beitrag zum Problem der Neurosenwahl. *Internationale Zeitschrift für ärztliche Psychoanalyse*, I, 525–532; *GW*, VIII, p. 442–452; The disposition to obsessional neurosis: a contribution to the problem of choice of neurosis. *SE*, 12: 311–326.
- . (1913j). Das Interesse an der Psychoanalyse. *Scientia*, XIV, 240–250, 369–384; *GW*, VIII, p. 389–420; The claims of psycho-analysis to scientific interest. *SE*, 13: 163–190.
- . (1914a). Über fausse reconnaissance (“déjà raconté”) während der psychoanalytischen Arbeit. *Internationale Zeitschrift für ärztliche Psychoanalyse*, II, 1–5; *GW*, X, p. 116–123; Fausse reconnaissance (“déjà raconté”) in psycho-analytic treatment. *SE*, 13: 199–207.
- . (1914b). Der Moses des Michelangelo. *Imago*, III, 15–36; *GW*, X, p. 172–201; The Moses of Michelangelo. *SE*, 13: 209–238.
- . (1914c). Zur Einführung des Narzissmus. *Jahrbuch für Psychoanalyse*, VI, 1–24; *GW*, X, p. 137–170; On narcissism: an introduction. *SE*, 14: 67–102.
- . (1914d). Zur Geschichte der psychoanalytischen Bewegung. *Jahrbuch für Psychoanalyse*, VI, 207–260; *GW*, X, p. 43–113; On the history of the psycho-analytic movement. *SE*, 14: 1–66.
- . (1914f). *Zur Psychologie des Gymnasiasten*. In *Festschrift anlässlich des 50jährigen Bestehens des K. k. Erzherzog Rainer-Realgymnasiums in Wien (Oktober 1914)*. Wien; *GW*, X, p. 204–207; Some reflections on schoolboy psychology. *SE*, 13: 239–244.
- . (1914g). Erinnern, Wiederholen und Durcharbeiten (Weitere Ratschläge zur Technik der Psychoanalyse, II). *Internationale Zeitschrift für ärztliche Psychoanalyse*, II, 485–491; *GW*, X, p. 126–136; Remembering, repeating and working-through (Further recommendations on the technique of psycho-analysis II). *SE*, 12: 145–156.
- . (1915a [1914]). Bemerkungen über die Übertragungsliebe (Weitere Ratschläge zur Technik der Psychoanalyse, III). *Internationale Zeitschrift für ärztliche Psychoanalyse*, III, 1–11; *GW*, X, p. 306–321; Observations on transference love (Further recommendations on the technique of psycho-analysis III). *SE*, 12: 157–171.
- . (1915b). Zeitgemässes über Krieg und Tod. *Imago*, IV, 1–21; *GW*, X, p. 324–355; Thoughts for the times on war and death. *SE*, 14: 273–300.
- . (1915c). Triebe und Triebchicksale. *Internationale Zeitschrift für ärztliche Psychoanalyse*, III, 84–100; *GW*, X, p. 210–232; Instincts and their vicissitudes. *SE*, 14: 109–140.
- . (1915d). Die Verdrängung. *Internationale Zeitschrift für ärztliche Psychoanalyse*, III, 129–138; *GW*, X, p. 248–261; Repression. *SE*, 14: 141–158.
- . (1915e). Das Unbewusste. *Internationale Zeitschrift für ärztliche Psychoanalyse*, III, 57–69,

- 189–203; *GW*, X, p. 264–303; The unconscious. *SE*, 14: 159–204.
- . (1915f). Mitteilung eines der psychoanalytischen Theorie widersprechenden Falles von Paranoia. *Internationale Zeitschrift für ärztliche Psychoanalyse*, III, 321–329; *GW*, X, p. 234–246; A case of paranoia running counter to the psycho-analytic theory of the disease. *SE*, 14: 261–272.
- . (1916–17a [1915–17]). *Vorlesungen zur Einführung in die Psychoanalyse*. Leipzig-Wien: Hugo Heller; *GW*, XI; Introductory lectures on psycho-analysis. Parts I & II. *SE*, Part I 15, Part II 16.
- . (1916–17b). Mythologische Parallele zu einer plastischen Zwangsvorstellung. *Internationale Zeitschrift für ärztliche Psychoanalyse*, IV, 110 ; A mythological parallel to a visual obsession. *SE*, 14: 337–338.
- . (1916–17c). Eine Beziehung zwischen einem Symbol und einem Symptom. *Internationale Zeitschrift für ärztliche Psychoanalyse*, IV, 111 ; *GW*, X, p. 394 ; A connection between a symbol and a symptom. *SE*, 14: 339–340.
- . (1916–17e). Über Triebumsetzungen. Insbesondere der Analerotik. *Internationale Zeitschrift für ärztliche Psychoanalyse*, IV, 125–130; *GW*, X, p. 402–410; On transformations of instinct as exemplified in anal erotism. *SE*, 17: 125–133.
- . (1916–17f [1915]). Metapsychologische Ergänzung zur Traumlehre. *Internationale Zeitschrift für ärztliche Psychoanalyse*, IV, 277–287; *GW*, X, p. 412–426; A metapsychological supplement to the theory of dreams. *SE*, 14: 217–235.
- . (1916–17g [1915]). Trauer und Melancholie. *Internationale Zeitschrift für ärztliche Psychoanalyse*, IV, 288–301; *GW*, X, p. 428–446; Mourning and melancholia. *SE*, 14: 237–258.
- . (1916a [1915]). Vergänglichkeit. In Berliner Goethebund (Ed.), *Das Land Goethes 1914–1916* (p. 37 ). Stuttgart-Berlin: Deutsche Verlagsanstalt.; *GW*, X, p. 358–361; On transience. *SE*, 14: 303–307.
- . (1916d). Einige Charaktertypen aus der psychoanalytischen Arbeit. *Imago*, IV, 317–336; *GW*, X, p. 364–391; Some character-types met with in psycho-analytic work. *SE*, 14: 309–333.
- . (1917a [1916]). Eine Schwierigkeit der Psychoanalyse. *Imago*, V, 1–7; *GW*, XII, p. 3–12; A difficulty in the path of psycho-analysis, *SE*, 17, 135–144.
- . (1917b). Eine Kindheitserinnerung aus Dichtung und Wahrheit. *Imago*, V, 49–57; *GW*, XII, p. 15–26; A childhood recollection from “Dichtung und Wahrheit”. *SE*, 17: 145–156.
- . (1918a [1917]). Das Tabu der Virginität (Beiträge zur Psychologie des Liebeslebens, III). In *Sammlung kleiner Schriften zur Neurosenlehre* (Vol. IV, pp. 229–251). Leipzig-Wien: F. Deuticke; *GW*, XII, p. 159–180; The taboo of virginity. *SE*, 11: 191–208.
- . (1918b [1914]). Aus der Geschichte einer infantilen Neurose (“DerWolfsmann”). In *Sammlung kleiner Schriften zur Neurosenlehre* (Vol. IV, pp. 578–717). Leipzig-Wien: F. Deuticke; *GW*, XII, p. 27–157; From the history of an infantile neurosis. *SE*, 17: 1–122.
- . (1919a [1918]). Wege der psychoanalytischen Therapie. *Internationale Zeitschrift für ärztliche Psychoanalyse*, V, 61–68; *GW*, XII, p. 183–194; Lines of advance in psycho-analytic therapy. *SE*, 17: 157–168.
- . (1919b). James J. Putnam. *Internationale Zeitschrift für ärztliche Psychoanalyse*, V, 136; *GW*, XII, p. 315; James J. Putnam. *SE*, 17: 271–272.
- . (1919d). Einleitung. In E. SIMMEL: Zur Psychoanalyse der Kriegsneurosen, Leipzig-Wien: Internationaler psychoanalytischer Verlag, p. 3–7; *GW*, XII, p. 321–324; Introduction to psycho-analysis and the war neuroses”. *SE*, 17: 205–210.
- . (1919e). Ein Kind wird geschlagen. Beitrag zur Kenntnis der Entstehung sexueller Perversionen. *Internationale Zeitschrift für ärztliche Psychoanalyse*, V, 151–172; *GW*, XII, p. 197–226; ‘A child is being beaten’: a contribution to the study of the origin of sexual perversions. *SE*, 17: 175–204.
- . (1919f). Victor Tausk. *Internationale Zeitschrift für ärztliche Psychoanalyse*, V, 225–227; *GW*, XII, p. 316–318; Victor Tausk. *SE*, 17: 273–275.
- . (1919g). Vorrede. In Theodor Reik, *Probleme der Religionspsychologie* (Vol I., Teil, Das Ritual; pp. VII–XII). Leipzig-Wien: Internationaler psychoanalytischer Verlag; *GW*, XII, p. 325–329; Preface to Reik’s Ritual: Psycho-analytic Studies. *SE*, 17: 257–263.
- . (1919h). Das Unheimliche. *Imago*, V, 297–324; *GW*, XII, p. 229–268; The ‘uncanny’. *SE*, 17: 217–256.
- . (1919j [1918]). Kell-e az egyetemen a psychoanalyst tanitani ? [Soll die Psychoanalyse an den Universitäten gelehrt werden ?]. *Gyógyászat*, LIX, 192; *GW*, Nachtr., p. 699–703; On the teaching of psycho-analysis in universities. *SE*, 17: 169–173.
- . (1920a). Über die Psychogenese eines Falles von weiblicher Homosexualität. *Internationale Zeitschrift für (ärztliche) Psychoanalyse*, VI, 1–24; The psychogenesis of a case of homosexuality in a woman. *SE*, 18: 145–172.
- . (1920b). Zur Vorgeschichte der analytischen Technik. *Internationale Zeitschrift für (ärztliche)*

- Psychoanalyse*, VI, 79–81; GW, XII, p. 309–312; A note on the prehistory of the technique of analysis. *SE*, 18: 263–265.
- . (1920c). Dr Anton von Freund. *Internationale Zeitschrift für (ärztliche) Psychoanalyse*, VI, 95 ; GW, XIII, p. 435 ; Dr. Anton von Freund. *SE*, 18: 267–268.
- . (1920f). Ergänzungen zur Traumlehre. *Internationale Zeitschrift für (ärztliche) Psychoanalyse*, VI, 397 ; GW, Nachtr., p. 622 ; Supplements to the theory of dreams. *SE*, 18: 4–4.
- . (1920g). *Jenseits des Lustprinzips*. Leipzig-Wien-Zürich: Internationaler psychoanalytischer Verlag; GW, XIII, p. 1–69; Beyond the pleasure principle. *SE*, 18: 1–64.
- . (1921c). *Massenpsychologie und Ich-Analyse*. Leipzig-Wien-Zürich: Internationaler psychoanalytischer Verlag; GW, XIII, p. 71–161; Group psychology and the analysis of the ego. *SE*, 18: 65–143.
- . (1922a). Traum und Telepathie. *Imago*, VIII, 1–22; GW, XIII, p. 165–191; Dreams and telepathy. *SE*, 18: 195–220.
- . (1922b [1921]). Über einige neurotische Mechanismen bei Eifersucht, Paranoia und Homosexualität. *Internationale Zeitschrift für (ärztliche) Psychoanalyse*, VIII, 249–258; GW, XIII, p. 195–207; Neurotic mechanisms in jealousy, paranoia and homosexuality. *SE*, 18: 221–232.
- . (1922c). Nachschrift zur Analyse des kleinen Hans [1909b]. *Internationale Zeitschrift für (ärztliche) Psychoanalyse*, VIII, 321; GW, XIII, p. 431 ; Postscript. *SE*, 10: 148
- . (1922e). Geleitwort. In R. de Saussure, *La Méthode psychanalytique* (p. VII ). Lausanne-Genève: Payot; GW, Nachtr., p. 752 ; Preface to Raymond di Saussure's "The Psycho-Analytic Method". *SE*, 19: 283–284.
- . (1923a [1922]). Libidotheorie. *Psychoanalyse*. In M. Marcuse (Ed.), *Handwörterbuch der Sexualwissenschaft* (pp. 296–298, 377–383). Bonn,; GW, XIII, p. 211–233; Encyclopaedia article: Psychoanalysis and The libido theory". *SE*, 18: 234–254, 255–259.
- . (1923b). Das Ich und das Es, Leipzig-Wien-Zürich: Internationaler psychoanalytischer Verlag; GW, XIII, p. 237–289; The ego and the id. *SE*, 19: 1–66.
- . (1923c [1922]). Bemerkungen zur Theorie und Praxis der Traumdeutung. *Internationale Zeitschrift für (ärztliche) Psychoanalyse*, IX, p. 1–11; GW, XIII, p. 301–314; Remarks on the theory and practice of dream-interpretation. *SE*, 19: 107–121.
- . (1923d [1922]). Eine Teufelsneurose im siebenzehnten Jahrhundert. *Imago*, IX, 1–34; GW, XIII, p. 317–353; A seventeenth-century demonological neurosis. *SE*, 19: 67–105.
- . (1923e). Die infantile Genitalorganisation (Eine Einschaltung in die Sexualtheorie). *Internationale Zeitschrift für (ärztliche) Psychoanalyse*, IX, 168–171; GW, XIII, p. 293–298; The infantile genital organization (An interpolation into the theory of sexuality). *SE*, 19:141–145.
- . (1923f). Josef Popper-Lynkeus und die Theorie des Traumes. *Allgemeine Nährpflicht*, VI; GW, XIII, p. 357–359; Josef Popper-Lynkeus and the theory of dreams. *SE*, 19: 259–263.
- . (1924a). Lettre à Le Disque Vert (February 26, 1924). *Le Disque Vert*, II, p. 3; GW, XIII, p. 446; Letter to Le Disque Vert. *SE*, 19: 290–290.
- . (1924b [1923]). Neurose und Psychose. *Internationale Zeitschrift für (ärztliche) Psychoanalyse*, X, 1–5; GW, XIII, p. 387–391; Neurosis and psychosis. *SE*, 19: 147–153.
- . (1924c). Das ökonomische Problem des Masochismus. *Internationale Zeitschrift für (ärztliche) Psychoanalyse*, X, 121–133; GW, XIII, p. 371–383; The economic problem of masochism. *SE*, 19: 155–170
- . (1924d). Der Untergang des Ödipuskomplexes. *Internationale Zeitschrift für (ärztliche) Psychoanalyse*, X, 245–252; GW, XIII, p. 395–402; The dissolution of the oedipus complex. *SE*, 19: 171–179.
- . (1924e). Der Realitätsverlust bei Neurose und Psychose. *Internationale Zeitschrift für (ärztliche) Psychoanalyse*, X, 374–379; GW, XIII, p. 363–368; The loss of reality in neurosis and psychosis. *SE*, 19: 180–187.
- . (1924f [1923]). Kurzer Abriss der Psychoanalyse, 1. *Veröffentl.:Psychoanalysis: Exploring the Hidden Recesses of the Mind*. Übersetzt; GW, XIII, p. 405–427; *A short account of psycho-analysis*. *SE*, 19: 189–209.
- . (1925a [1924]). Notiz über den "Wunderblock". *Internationale Zeitschrift für (ärztliche) Psychoanalyse*, XI, 1–5; GW, XIV, p. 3–8; A note upon the 'mystic writing pad'. *SE*, 19: 225–232.
- . (1925d [1924]). Selbstdarstellung. In L.R. Grote (Ed.), *Die Medizin der Gegenwart in Selbstdarstellungen* (Vol. IV, p. 1–52). Leipzig: Felix Meiner; GW, XIV, p. 31–96; An autobiographical study. *SE*, 20: 1–74.
- . (1925e [1924]). Die Widerstände gegen die Psychoanalyse. *Imago*, XI, 222–233; GW, XIV, p. 99–110; The resistances to psycho-analysis. *SE*, 19: 211–222.
- . (1925f). Geleitwort. In A. Aichhorn, *Verwahrloste Jugend. Die Psychoanalyse in der Fürsorgeerziehung* (pp. 3–6). Leipzig-Wien-Zürich: Internationaler

- psychoanalytischer Verlag; GW, XIV, p. 565–567; Preface to Aichhorn's *Wayward Youth*. *SE*, 19: 271–275.
- . (1925h). Die Verneinung. *Imago*, XI, p. 217–221; GW, XIV, p. 11–15; Negation. *SE*, 19: 233–239.
- . (1925i). *Einige Nachträge zum Ganzen der Traumdeutung, als Zusatzkapitel C zur Traumdeutung (1900a)*. Wien; GW, I, p. 561–573; Some additional notes on dream-interpretation as a whole. *SE*, 19: 123–138.
- . (1925j). Einige psychische Folgen des anatomischen Geschlechtsunterschieds. *Internationale Zeitschrift für (ärztliche) Psychoanalyse*, XI, 401–410; GW, XIV, p. 19–30; Some psychical consequences of the anatomical distinction between the sexes. *SE*, 19: 241–258.
- . (1926d [1925]). *Hemmung, Symptom und Angst*. Leipzig-Wien-Zürich: Internationaler psychoanalytischer Verlag; GW, XIV, p. 111–205; Inhibitions, symptoms and anxiety. *SE*, 20: 75–172.
- . (1926e). *Die Frage der Laienanalyse. Unterredungen mit einem Unparteiischen*. Leipzig-Wien-Zürich: Internationaler psychoanalytischer Verlag; GW, XIV, p. 207–286; The question of lay analysis. *SE*, 20: 177–250.
- . (1926f). Psycho-Analysis: Freudian School. In *Encyclopædia Britannica* (Vol. III, pp. 253–255). London: 13th ed.; GW, XIV, p. 299–307; Psycho-analysis. *SE*, 20: 259–270.
- . (1927a). Nachwort zur Frage der Laienanalyse (1926e). *Internationale Zeitschrift für (ärztliche) Psychoanalyse*, XIII, 326–332; GW, XIV, p. 287–296; Postscript: The question of lay analysis. *SE*, 20: 251–258.
- . (1927b). Nachtrag zur Arbeit über den Moses des Michelangelo (1914b). *Imago*, XIII, 552; GW, XIV, p. 321 ; Postscript: The Moses of Michelangelo. *SE*, 13: 237–237.
- . (1927c). *Die Zukunft einer Illusion*. Leipzig-Wien-Zürich: Internationaler psychoanalytischer Verlag; GW, XIV, p. 325–380; The future of an illusion. *SE*, 21: 1–56.
- . (1927d). Der Humor. In *Almanach für das Jahr 1928* (p. 9–16). Wien: Internationaler psychoanalytischer Verlag; GW, XIV, p. 383–389; Humour. *SE*, 21: 159–166.
- . (1927e). Fetischismus, (dir.). *Almanach für das Jahr 1928* (p. 17–24). Wien: Internationaler psychoanalytischer Verlag; GW, XIV, p. 311–317; Fetishism. *SE*, 21: 147–157.
- . (1928b [1927]). Dostojewski und die Vätertötung. In R. Fülöp-Miller and F. Eckstein (Eds.), *Die Urgestalt der Brüder Karamasoff* (p. XI–XXXVI). München: Moeller Van den Bruck; GW, XIV, p. 399–418; Dostoyevsky and parricide. *SE*, 21: 173–196.
- . (1930a [1929]). *Das Unbehagen in der Kultur*. Leipzig-Wien-Zürich: Internationaler psychoanalytischer Verlag; GW, XIV, p. 419–506; Civilization and its discontents. *SE*, 21: 57–145.
- . (1930d). Brief an Dr. Alfons Paquet (August 3, 1930). *Psychoanalytische Bewegung*, II, 419; GW, XIV, p. 545 ; Letter to Dr. Alfons Paquet. *SE*, Vol, 21, 207–207.
- . (1930e). Ansprache im Frankfurter Goethe-Haus. *Psychoanalytische Bewegung*, II, 421–426; GW, XIV, p. 547–550; Address delivered in the Goethe Haus at Frankfurt. *SE*, 21: 208–212.
- . (1931a). Über libidinöse Typen. *Internationale Zeitschrift für (ärztliche) Psychoanalyse*, XVII, 313–316; GW, XIV, p. 509–513; Libidinal types. *SE*, 21: 215–220.
- . (1931b). Über die weibliche Sexualität. *Internationale Zeitschrift für (ärztliche) Psychoanalyse*, XVII, 317–332; GW, XIV, p. 517–537; Female sexuality. *SE*, 21: 221–243.
- . (1931d). Das Fakultätsgutachten im Prozess Halsmann. *Psychoanalytische Bewegung*, III, 32–34; GW, XIV, p. 541 ; The expert opinion in the Halsmann case. *SE*, 21: 251–253.
- . (1932a [1931]). Zur Gewinnung des Feuers. *Imago*, XVIII, 8–13; GW, XVI, p. 3–9; The acquisition and control of fire, *SE*, 22: 183–193.
- . (1933a [1932]). *Neue Folge der Vorlesungen zur Einführung in die Psychoanalyse*. Leipzig-Wien-Zürich: Internationaler psychoanalytischer Verlag; GW, XV; New introductory lectures on psycho-analysis. *SE*, 22: 1–182.
- . (1933b [1932]). Warum Krieg? (Brief an Albert Einstein, Sept. 1932). In *Warum Krieg? Pourquoi la guerre? Why War?* Internationales Institut für geistige Zusammenarbeit am Völkerbund (Institut international de coopération intellectuelle); GW, XVI, p. 13–27; Why war? (Einstein and Freud). *SE*, 22: 195–215.
- . (1933c). Sándor Ferenczi. *Internationale Zeitschrift für (ärztliche) Psychoanalyse*, XIX, 301–304; GW, XVI, p. 267–269; Sandor Ferenczi. *SE*, 22: 225–229.
- . (1936a). Brief an Romain Rolland: Eine Erinnerungsstörung auf der Akropolis. In *Almanach der Psychoanalyse 1937* (pp. 9–21). Wien: Internationaler psychoanalytischer Verlag; GW, XVI, p. 250–257; A disturbance of memory on the Acropolis (An open

- letter to Romain Rolland on the occasion of his seventieth birthday). *SE*, 22: 239–248.
- . (1936b [1932]). Vorwort (Brief von July 3, 1932). In R. Sterba, *Handwörterbuch der Psychoanalyse*. Wien: Internationaler psychoanalytischer Verlag; *GW*, Nachtr., p. 761; Preface to Richard Sterba's *Dictionary of psycho-analysis*. *SE*, 22: 253–253.
- . (1937c). Die endliche und die unendliche Analyse. *Internationale Zeitschrift für (ärztliche) Psychoanalyse*, XXIII, 209–240; *GW*, XVI, p. 59–99; Analysis terminable and interminable. *SE*, 23: 209–253.
- . (1937d). Konstruktionen in der Analyse. *Internationale Zeitschrift für (ärztliche) Psychoanalyse*, XXIII, 459–469; *GW*, XVI, p. 43–56; Constructions in analysis. *SE*, 23: 255–269.
- . (1937e). Wenn Moses ein Ägypter war... *Imago*, XXIII, 387–419; *GW*, XVI, p. 114–155; If Moses was an Egyptian. *SE*, 23: 17–53.
- . (1939a [1934–38]). *Der Mann Moses und die monotheistische Religion: Drei Abhandlungen*. Amsterdam: Allert De Lange; *GW*, XVI, p. 103–246; Moses and monotheism: three essays. *SE*, 23: 1–137.
- . (1940a [1938]). Abriss der Psychoanalyse. *Internationale Zeitschrift für Psychoanalyse Imago*, XXV, 7–67; *GW*, XVII, p. 63–138; An outline of psycho-analysis. *SE*, 23: 139–207.
- . (1940b [1938]). Some elementary lessons in psycho-analysis. *Internationale Zeitschrift für Psychoanalyse Imago*, XXV, 21 ; *GW*, XVII, p. 139–147; Some elementary lessons in psycho-analysis. *SE*, 23: 279–286.
- . (1940c [1922]). Das Medusenhaupt. *Internationale Zeitschrift für (ärztliche) Psychoanalyse Imago*, XXV, 105 ; *GW*, XVII, p. 45, 47 ; Medusa's head. *SE*, 18: 273–274.
- . (1940e [1938]). Die Ichspaltung im Abwehrevorgang. *Internationale Zeitschrift für Psychoanalyse Imago*, XXV, 241–244; *GW*, XVII, p. 57–62; Splitting of the ego in the process of defence. *SE*, 23: 271–278.
- . (1941d [1921]). Psychoanalyse und Telepathie; *GW*, XVII, p. 25, 27–44; Psycho-analysis and telepathy. *SE*, 18: 173–193.
- . (1941f [1938]). Ergebnisse, Ideen, Probleme; *GW*, XVII, p. 149, 151 ; Findings, ideas, problems. *SE*, 23: 299–300.
- . (1942a [1905–06]). Psychopathic characters on the stage (Psychopathische Personen auf der Bühne), *Psychoanalytic Quarterly*, XI, 459–464; *GW*, Nachtr., p. 655–661; Psychopathic characters on the stage. *SE*, 7: 305–310.
- . (1950a [1887–1902]). *Aus den Anfängen der Psychoanalyse, Briefe an Wilhelm Fliess, Abhandlungen und Notizen aus den Jahren 1887–1902* (Marie Bonaparte, Anna Freud, and Ernst Kris, Eds.). London: Imago Publishing; Extracts from the Fliess papers. *SE*, 1: 173–280.
- . (1950c [1895]). Entwurf einer Psychologie, In Marie Bonaparte, Anna Freud, and Ernst Kris (Eds.), *Aus den Anfängen der Psychoanalyse, Briefe an Wilhelm Fliess, Abhandlungen und Notizen aus den Jahren 1887–1902*. London: Imago Publishing; *GW*, Nachtr., p. 387–477; Project for a scientific psychology. *SE*, 1: 281–387.
- . (1951a [1935]). A letter on homosexuality, to N. N. (April 9, 1935). *American Journal of Psychiatry*, CVII, 786; *International Journal of Psychoanalysis*, XXXII, 331.
- . (1955a [1907–08]). *L'Homme aux rats, Journal d'une analyse* (E.R. Hawelka, Ed.). Paris: Presses Universitaires de France; *GW*, Nachtr., p. 509–569; Notes upon a case of obsessional neurosis ("The Rat Man"). *SE*, 10: 151–318.
- . (1956a [1886]). Report on my studies in Paris and Berlin, on a travelling bursary granted from the University jubilee fund, 1885, *International Journal of Psychoanalysis*, XXXVII, 2–7; Report on my studies in Paris and Berlin. *SE*, 1: 1–15.
- . (1960a [1873–1939]). Briefe 1873–1939, Ernst Freud und Lucie Freud Ed., Frankfurt am Main: Fischer; Letters of Sigmund Freud, 1873–1939; (Ernst L. Freud, Ed.; Tania and James Stern, Trans.). London: Hogarth Press, 1970.
- . (1960b [1885]). Curriculum vitae. In J. Gicklhorn and R. Gicklhorn, *Sigmund Freuds akademische Laufbahn im Lichte der Dokumente*. Wien-Innsbruck: Urban & Schwarzenberg; *GW*, Nachtr., p. 46.
- . (1963a [1909–39]). *Sigmund Freud, Oskar Pfister, Briefe 1909–1939* (E.L. Freud, H. Meng, Eds.). Frankfurt am Main; *Psycho-analysis and faith; the letters of Sigmund Freud & Oskar Pfister*. (Heinrich Meng and Ernst L. Freud, Eds.; Eric Mosbacher, Trans.). London: Hogarth Press, 1963.
- . (1965a [1907–26]). *Sigmund Freud, Karl Abraham, Briefe 1907–1926* (Hilda C. Abraham and Ernst L. Freud Eds.). Frankfurt am Main: Fischer; *A psycho-analytic dialogue: the letters of Sigmund Freud and Karl Abraham, 1907–1926* Hilda C. Abraham and Ernst L. Freud, Eds.; Bernard Marsh and Hilda C. Abraham, Trans.). New York: Basic Books, 1966.
- . (1966a [1912–36]). *Sigmund Freud-Lou Andreas-Salomé, Briefwechsel* (Ernst Pfeiffer, Ed.). Frankfurt am Main: Fischer; *Sigmund Freud and Lou Andreas-Salomé: letters* (Ernst Pfeiffer, Ed.; William

- and Elaine Robson-Scott, Trans.). London: Hogarth Press and the Institute of Psycho-Analysis, 1972.
- . (1966b [1938]). Einleitung. In Sigmund Freud, and William C. Bullitt, *Thomas Woodrow Wilson, Twenty-eighth President of the United States. A Psychological Study* (pp. XI–XVI). London-New York: Weidenfeld & Nicholson, 1967; GW, Nachtr., p. 686–692.
- . (1968a [1927–39]). *Sigmund Freud, Arnold Zweig, Briefwechsel* (Ernst L. Freud, Ed.). Frankfurt am Main: Fischer Verlag; *Sigmund Freud, Arnold Zweig; The letters of Sigmund Freud and Arnold Zweig* (Ernst Freud, Ed.; William and Elaine Robson-Scott, Trans.). New York: Harcourt, Brace & World, 1970.
- . (1970a [1919–36]). *Sigmund Freud as a Consultant: Recollections of a Pioneer in Psychoanalysis* (M. Grotjahn, Ed.). New York: Intercontinental Medical Book Corporation.
- . (1971a). *James Jackson Putnam and Psychoanalysis. Letters Between Putnam and Sigmund Freud, Ernest Jones, William James, Sándor Ferenczi, and Morton Prince, 1877–1917* (Nathan G. Hale, Ed.). Cambridge, MA: Harvard University Press.
- . (1974a [1906–13]). *Sigmund Freud-C. G. Jung, Briefwechsel* (W. McGuire, W. Sauerländer Ed.). Frankfurt am Main: Fischer; *The Freud/Jung letters: the correspondence between Sigmund Freud and C.G. Jung* (William McGuire, Ed.; Ralph Manheim and R.F.C. Hull, Trans.). Princeton, N.J.: Princeton University Press.
- . (1977h [1923–33]). Correspondance Freud-Laforgue, préface d'André Bourguignon. *Nouvelle Revue psychanalyse*, 15, 235–314.
- . (1985 [1915]). *Übersicht der Übertragungsneurosen. Ein bisher unbekanntes Manuskript* (Ilse Grubrich-Simitis, Ed.). Frankfurt am Main: Fischer; GW, Nachtr., p. 634–651; *A phylogenetic fantasy: overview of the transference neuroses* (Ilse Grubrich-Simitis, Ed.; Axel Hoffer and Peter T. Hoffer, Trans.). Cambridge, MA: Belknap Press of Harvard University Press, 1987.
- . (1985c [1887–1904]). *The complete letters of Sigmund Freud to Wilhelm Fliess 1887–1904* (J.M. Mason, Ed. and Trans.). Cambridge, MA/London: Harvard University Press.
- . (1987c [1908–38]). *Correspondance Sigmund Freud-Stefan Zweig*. Paris: Rivages Poche.
- . (1989a [1871–81, 1910]). *Jugendbriefe an Eduard Silberstein 1871–1881* (W. Boehlich, Ed.). Frankfurt am Main: Fischer; *The letters of Sigmund Freud to Eduard Silberstein, 1871–1881* (Walter Boehlich, Ed.; Arnold J. Pomerans, Trans.). Cambridge, MA: Belknap Press, 1990.
- . (1992 [1908–38]). *Sigmund Freud-Ludwig Binswanger: Briefwechsel 1908–1938* (Gerhard Fichtner, Ed.). Frankfurt am Main: Fischer; *The Sigmund Freud-Ludwig Binswanger correspondence 1908–1938* (Gerhard Fichtner, Ed.; Arnold J. Pomerans, Trans.). New York: Other Press, 2003.
- . (1993 [1908–39]). *The complete correspondence of Sigmund Freud and Ernest Jones, 1908–1939* (R.A. Paskauskas, Ed.). London: The Belknap Press of Harvard University Press.
- . (1996 [1911–38]). *Lettres de famille de S. Freud et des Freud de Manchester, 1911–1938* (C. Vincent, Trans.). Paris: Presses Universitaires de France.
- Freud Sigmund, and Breuer, Josef. (1893a). Über den psychischen Mechanismus hysterischer Phänomene Vorläufige Mitteilung.. *Neurologisches Zeitblatt*, XII; GW, I, p. 81–98; On the psychical mechanism of hysterical phenomena: preliminary communication. *SE*, 2: 1–17.
- . (1895d). Studien über Hysterie, Leipzig-Wien: F. Deuticke; GW, I, p. 75–312; Studies on hysteria. *SE*, 2: 48–106.
- . (1940d [1892]). Zur Theorie des hysterischen Anfalls. *Internationale Zeitschrift für Psychoanalyse Imago*, XXV, 1940, p. 107–110; GW, XVII, p. 7, 9–13; On the theory of hysterical attacks. *SE*, 1: 151–154.
- Freud Sigmund, and, Ferenczi Sándor. (1993–2000). *The correspondence of Sigmund Freud and Sándor Ferenczi* (Eva Brabant, Ernst Falzeder, and Patrizia Giamperri-Deutsch, Eds.). Cambridge, MA: Belknap Press of Harvard University Press.
- Freud Sigmund, and, Freud, Anna (Trans.). (1939b). *Topsy, der goldhaarige Chow*. Amsterdam: Allert De Lange; *Topsy: the story of a golden-haired chow by Marie Bonaparte*. New Brunswick, NJ: Transaction Publishers, 1994.
- SE: The Standard Edition of the complete psychological works of Sigmund Freud*. Translated from the German under the General Editorship of James Strachey. In Collaboration with Anna Freud. Assisted by Alix Strachey and Alan Tyson. London: The Hogarth Press and The Institute of Psycho-Analysis. This Edition first published in 1966. Reprinted in 1968, 1971, 1973, 1975, 1978, 1981 and 1986.





# GENERAL BIBLIOGRAPHY

## ГЕНЕРАЛ ВІБЛІОГРАФІЯ

- A. Z. (1919). Tratamiento psicoanalítico de un caso de neurosis compulsiva. *Revista de psiquiatría y disciplinas conexas*, II (1), p. 22–25.
- Abend, Sander. (1979). Unconscious fantasy and theories of cure. *Journal of the American Psychoanalytic Association*, 27, 579–596.
- . (1982). Reality testing as a clinical concept. *Psychoanalytic Quarterly*, 51, 218–238.
- . (1989). Countertransference and psychoanalytic technique. *Psychoanalytic Quarterly*, 58, 374–395.
- Abensour, Liliane. (1999). *Evelyne Kestemberg*. Paris: Presses Universitaires de France.
- Aberastury, Arminda. (1959). Una experiencia psicodramática con niños. In E. J. Salas, G. Smolensky, L. Grinberg, M. Langer, and E. Rodrigue (eds.), *El grupo psicologico*. Buenos Aires: Nova, APA, 1959.
- . (1978). *La paternidad*, Buenos Aires: Kargie-man, 2nd ed., 1985; A. Aberastury, E. J. Salas, *A paternidade: Um enfoque psicanalítico*.
- Aberastury, Arminda, Aberastury, Marcelo, and Cesio, Fidas. (1967). *Historia enseñanza y ejercicio legal del psicoanálisis*. Buenos Aires: Bibliografica Omeba.
- Aberbach, David. (1984). Loss and dreams. *International Review of Psychoanalysis*, 11, 383–398.
- Abraham, G. (2002). The psychodynamics of orgasm. *International Journal of Psychoanalysis*, 83, 325–338.
- Abraham, Karl. (1912). Préliminaires à l'investigation et au traitement psychanalytique de la folie maniaco-dépressive et des états voisins OC, t. I, p. 99–113.
- . (1913). *Dreams and myths: a study in race psychology* (William A. White, Trans.). New York: Journal of Nervous and Mental Disease Publishing Co. (Original work published 1909.)
- . (1921). Literatur in spanischer Sprache. *Bericht über die Fortschritte der Psychoanalyse in den Jahren 1914–1919*. Leipzig-Wien-Zürich, Internationaler psychoanalytischer Verlag, 366–367.
- . (1924). Melancholia and obsessional neurosis: two stages of the anal-sadistic phase of the libido. In *Selected papers in psychoanalysis*. (Douglas Bryan and Alix Strachey, Trans.). London: Hogarth Press.
- . (1924). The process of introjection in melancholia: two stages of the oral phase of the libido. In *Selected papers in psychoanalysis*. (Douglas Bryan and Alix Strachey, Trans.). London: Hogarth Press.
- . (1927). A short study of the development of the libido, viewed in the light of mental disorders. In *Selected papers of Karl Abraham, M.D.* London: Hogarth. (Original work published 1924)
- . (1927). Notes on the psycho-analytical investigation and treatment of manic-depressive insanity and allied conditions. In Douglas Bryan and Alix Strachey (Trans.), *Selected papers of Karl Abraham, M.D.* (pp. 137–156). London: Hogarth and the Institute of Psycho-analysis. (Original work published 1911)
- . (1927). The first pregenital stage of the libido. In *Selected papers of Karl Abraham* (Douglas Bryan and Alix Strachey, Trans.). London: Hogarth Press. (Original work published 1916)
- . (1927). The influence of oral erotism on character-formation. In *Selected papers of Karl Abraham* (Douglas Bryan and Alix Strachey, Trans., pp. 393–406). London: Hogarth and the Institute of Psychoanalysis. (Original work published 1925)
- . (1927). The process of introjection in melancholia: two stages of the oral phase of the libido. In Douglas Bryan and Alix Strachey (Trans.). *Selected papers of Karl Abraham, M.D.* (pp. 442–452). London: Hogarth. (Original work published 1924)
- . (1927). The psychological relations between sexuality and alcoholism. In *Selected papers on psycho-*

- analysis*, London: Hogarth Press. (Original work published 1908)
- . (1949). Dreams and myths: A study in race psychology. In *Selected papers of Karl Abraham, M.D.* (Douglas Bryan and Alix Strachey, Trans.). London: Hogarth Press and the Institute of Psycho-Analysis. (Original work published 1909)
- . (1949). The influence of oral erotism on character formation. In *Selected papers of Karl Abraham, M.D.* (Douglas Bryan and Alix Strachey, Trans.). London: Hogarth and the Institute of Psycho-analysis. (Original work published 1925)
- . (1949). The narcissistic evaluation of excretory processes in dreams and neurosis. In *Selected papers of Karl Abraham, M.D.* (Douglas Bryan and Alix Strachey, Trans.). London: Hogarth Press and the Institute of Psycho-analysis. (Original work published 1920)
- . (1953–1955). Contribution of the theory of the anal character. In *Selected papers of Karl Abraham, M.D.* (Douglas Bryan and Alix Strachey, Trans.). New York: Basic Books. (Original work published 1925)
- . (1954). Contribution to a discussion on tic. In *Selected papers of Karl Abraham, M.D.* (pp. 323–325). (Douglas Bryan and Alix Strachey, Trans.). London, New York: Basic Books. (Original work published 1921)
- . (1966). Examen de l'étape pré-génitale la plus précoce du développement de la libido. *Complete Works*, vol. 2, 1915–1925. (pp. 231–254). (I. Barande, Trans.). Paris: Payot. (Original work published 1916)
- . (1979). A particular form of neurotic resistance against the psycho-analytic method. (pp. 303–311). In *Selected papers of Karl Abraham, M.D.* (Douglas Bryan and Alix Strachey, Trans.). New York: Brunner/Mazel. (Original work published 1927)
- . (1979). The experiencing of sexual traumas as a form of sexual activity. In *Selected papers on psychoanalysis*. New York: Brunner/Mazel. (Original work published 1907)
- . (1991). Six lettres inédites à W. Fliess. A. Buf-fel, E. Porge. *Littoral*, 31–32, pp. 247–257.
- Abraham, Nicolas. (1962). Preface to Sándor Ferenczi, *Thalassa. Psychanalyse des origines de la vie sexuelle*. Translated into French by J. Dupont and S. Samama. Paris: Payot.
- . (1963). Le crime de l'introjection. In *L'Écorce et le noyau* by Nicolas Abraham and Maria Torok. Paris: Aubier-Flammarion, 1978.
- . (1968). L'écorce et le noyau. *Critique*, 249.
- Abraham, Nicolas, and Torok, Maria. (1972). Deuil ou mélancolie: introjecter-incorporer. *Nouvelle Revue de psychanalyse*, 6, 111–122.
- . (1986). *The Wolf Man's magic word: A cryptonymy*. (Nicholas Rand, Trans.). Minneapolis: University of Minnesota Press. (Original work published 1976)
- . (1994). *The shell and the kernel: Renewals of psychoanalysis*. (Nicholas T. Rand, Ed. and Trans.). Chicago: University of Chicago Press. (Original work published 1978)
- . (1995). *Questions for Freud: The Secret History of Psychoanalysis*. Cambridge: Harvard University Press.
- Accerboni, Anna Maria (1988). Psychanalyse et fascisme: deux approches incompatibles. Le rôle difficile d'Edoardo Weiss. *Revue internationale d'histoire de la psychanalyse*, 1, 225–243.
- Accerboni, Anna Maria (1990). Sigmund Freud as remembered by Edoardo Weiss, the Italian pioneer of psychoanalysis. *International Review of Psycho-Analysis*, 17 (3), 351–359.
- Accerboni, Anna Maria. (1985). Un'opera che si raccomanda da sé. In Edoardo Weiss, *Elementi di psicoanalisi*. Pordenone, Italy: Studio Tesi.
- Accerboni-Pavanello, Anna Maria. (1992). Tatiana Rosenthal: une brève saison analytique. *Revue internationale d'histoire de la psychanalyse*, 5, 95–109.
- Adelman, Janet. (1992). *Suffocating mothers: fantasies of maternal origin in Shakespeare's plays. "Hamlet" to "The Tempest."* New York: Routledge.
- Adler, Alfred. (1908). Der Aggressionstrieb im Leben und in der Neurose. *Fortschrift. Med.*, 26.
- . (1926). *The neurotic constitution: outlines of a comparative individualistic psychology and psychotherapy* (Bernard Glueck and John E. Lind, Trans.). New York: Dodd, Mead, and Co. (Original work published 1912.)
- . (1938). Social interest: A challenge to mankind. London : Faber and Faber. (Original work published 1933.)
- . (1951). *The practice and theory of individual psychology* (P. Radin, Trans.). New York: Humanities Press. (Original work published 1920)
- . (1964). *Problems of neurosis: a book of case histories* (P. Mairet, Trans.). New York: Harper and Row. (Original work published 1929)
- . (1972). *The neurotic constitution: Outlines of a comparative individualistic psychology and psychotherapy* (Bernard Glueck and John E. Lind, Trans.). Freeport, NY: Books for Libraries Press. (Original work published 1930)
- . (1974). La pulsion d'agression dans la vie et dans la névrose. *Revue française de psychanalyse*, 38 (2–3), 417–426. (Original work published 1908)

- . (1979). *Superiority and social interest: A collection of later writings*. (Heinz L. Ansbacher and Rowena R. Ansbacher, Eds.). New York: Norton.
- . (1992). *Understanding human nature*. (Colin Brett, Trans.). Oxford: Oneworld. (Original work published 1927)
- . (2002). *The neurotic character. Fundamentals of individual psychology and psychotherapy* (Cees Koen, Trans.). San Francisco: Alfred Adler Institutes. (Original work published 1912)
- Adorno, Theodor. (1973). *Negative dialectics* (E. B. Ashton, Trans.). New York: Seabury Press.
- Adorno, Theodor, with Frankel-Brunswick, Else, Levinson, Daniel J., and Sanford, R. Nevitt. (1950). *The authoritarian personality*. New York: Harper and Row.
- Aeschlimann, Jürg. (1890). Rudolf Brun (1885–1969). *Leben und werk des zürcher neurologen, psychoanalytikers und entomologen. Zürcher medizingesch. Abhandlung*, 144, 1980.
- Agman, Gilles; Corcos, Maurice, and Jeammet, Philippe. (1994). Troubles des conduits alimentaires. In *Encyclopédie medico-chirurgicale (Psychiatrie vol., fasc. 37-350-A-10)*. Paris: Encyclopédie medico-chirurgicale.
- Aguirre Oar, José-Maria, and Guimon Ugartechea, José. (1994). *Vie et œuvre de Julian de Ajuriaguerra*. Paris: Masson.
- Aichhorn, August. (1935). *Wayward youth*. New York: The Viking Press.
- Ainsworth, Mary D. Salter. (1962). The effects of maternal deprivation: A review of findings and controversy in the context of research strategy. In Mary D. Ainsworth and R. G. Andry (Eds.), *Deprivation of maternal care*. Geneva: World Health Organization.
- Ainsworth, Mary D. Salter; Blehar, M. C.; Waters, E., and Wall, S. (1978). *Patterns of attachment: A psychological study of the strange situation*. Hillsdale, NJ: Lawrence Erlbaum.
- Aisenstein, Marilia. (1992). Des régressions impossibles? *Revue française de psychanalyse*, 56 (4), 995–1004.
- Aisenstein, Marilia; Fine, Alain; & Pragier, Georges (Eds.). (1995). *L'hypocondrie*. Paris: Presses Universitaires de France.
- Ajuriaguerra Julian. de. (1959). *L'Entraînement psychophysique par la relaxation*. Paris: Expansion scientifique.
- . (1980). *Handbook of child psychiatry and psychology*. (Raymond P. Lorion, Ed.). New York: Masson. (Original work published 1970)
- Ajuriaguerra, Julian de, and Casati, Irène. (1985). Ontogenèse des comportements de tendresse: I. Étude de l'embrassement-étreinte, à partir du pattern "tendre les bras." *Psychiatrie de l'enfant*, 28 (2), 325–402.
- Akhtar, Salman. (1994). Object constancy and adult psychopathology. *International Journal of Psychoanalysis*, 75, 441–456.
- Akhtar, Salman, Kramer, Selma, and Parens, Henri. (1996). *The internal mother. Conceptual and technical aspects of object constancy*. Northvale, NJ: Aronson, Inc.
- Albouy, Pierre. (1969). *Mythes et Mythologies dans la littérature française*. Paris: Armand Colin.
- Alexander Franz, and Staub, Hugo. (1956). *The criminal, the judge, and the public: A psychological analysis*, (rev. ed., Gregory Zilboorg, Trans.). Glencoe, IL: Free Press. (Original work published 1929)
- Alexander, Bernhard. (1927). Spinoza und Psychoanalyse. *Chronicum Spinosanum*, 5, 96–103.
- Alexander, Franz Gabriel. (1927). *Psychoanalyse der Gesamtpersönlichkeit; neun Vorlesungen über die Anwendung von Freud's Ich-Theorie auf die Neurosenlehre*. Leipzig, Vienna: Internationaler Psychoanalytischer Verlag.
- . (1950). *Psychosomatic medicine, its principles and applications*. New York: Norton.
- . (1961). *The scope of psychoanalysis. Selected papers of Franz Alexander*. New York: Basic Books.
- Alexander, Franz, and French, Thomas M. (1941). *Psychogenic factors in bronchial asthma*. Washington, DC: National Research Council.
- Alexander, Franz, and Selesnick, Sheldon T. (1966). *The history of psychiatry*. New York: Harper and Row.
- Alexandrian, Sarane. (1974). *Le surréalisme et le rêve*. Paris: Gallimard.
- Allday, Elizabeth. (1972). *Stefan Zweig: A critical biography*. Chicago: J. Philip O'Hara.
- Allendy, René. (1931). *La justice intérieure*. Paris: Denoël & Steele.
- . (1932). *La psychanalyse, doctrines et applications*. Paris: Denoël & Steele.
- . (1932). A case of eczema. *Psychoanalytic Review*, 19 (2), 152–163.
- . (1932). The mechanism of auto-punishment. *Psychoanalytic Review*, 19 (1), 72–76.
- . (1932). Various instincts and their development. *Psychoanalytic Review*, 19 (3), 310–318.
- . (1933). Sadism in woman. *Psychoanalytic Review*, 20, 4: 437–439.

- . (1934). *Essai sur la guérison*. Paris: Denoël & Steele.
- . (1937). *Paracelse, le médecin maudit*. Paris: Gallimard.
- . (1944). *Journal d'un médecin malade ou Six mois de lutte contre la mort*. Paris: Denoël.
- Allendy, René, and Allendy, Yvonne. (1931). *Capitalisme et sexualité*. Paris: Denoël & Steele.
- Allouch, Jean. (1994). *Marguerite, ou l'aimée de Lacan* (rev. ed.). Paris: E.P.E.L.
- Alnaes, Randolf. (1994). Psychoanalysis in Norway. History, training, treatment, and research. *Nordisk Journal of Psychiatry*, 32, 48.
- Althusser, Louis. (1966). Freud and Lacan. In his *Writings on psychoanalysis: Freud and Lacan* (Jeffrey Mehlman, Trans.). New York: Columbia University Press. (Original work published 1964)
- . (1993). *The future lasts forever: A memoir* (Richard Veasey, Trans.). New York: New Press.
- . (2001). Ideology and ideological state apparatuses. In his *Lenin and philosophy and other essays*. New York: Monthly Review Press. (Original work published 1970)
- Althusser, Louis, and Balibar, Étienne. (1979). *Reading "Capital"* (Ben Brewster, Trans.). New York: Schocken Books. (Original work published 1965)
- Alvarez de Toledo, Luisa. (1954). El análisis del "asociar", del "interpretar" y de "las palabras". *Revista de psicoanálisis de la Asociación psicoanalítica argentina*, XI (3), 267–313.
- . (1960). Ayahuasca. *Revista de psicoanálisis de la Asociación psicoanalítica argentina*, XVII (1), 1–9.
- . (1996). The analysis of "associating," "interpreting" words," con comentarios de Janine Puget y María Isabel Siquier. *International Journal of Psychoanalysis*, LXXVII, 291–322.
- Amar, Nadine; Bayle, Gérard, and Salem, Isaac. (1988). *Formation au psychodrame analytique*. Paris: Dunod.
- Amar, Nicole; Le Goues, Gérard, and Pragier, Georges (Eds.). (1995). *Surmoi II: les développements post-Freudiens*. Paris: Presses Universitaires de France.
- Amati Mehler, Jacqueline; Argentieri, Simona; Canestri, Jorge. (1993). *The Babel of the unconscious: Mother tongue and foreign tongues in the analytic dimension* (Jill Whitelaw-Cucco, Trans.). Madison, CT: International Universities Press.
- Anargyros-Klinger, Annie; Reiss-Schimmel, Ilana; Wainrib, Steve. (1998). *Création, psychanalyse*. Paris: Presses Universitaires de France.
- Anderson, James W. (1988). Henry A. Murray's early career: A psychobiographical exploration. *Journal of Personality*, 6 (1), 139–71.
- Anderson, Robin. (1992). *Clinical lectures on Klein and Bion* London, Karnac Books.
- Andersson, Ola. (1962). *Studies in the prehistory of psychoanalysis*. Stockholm: Svenska Bokförlaget.
- . A supplement to Freud's case history of "Frau Emmy von N.," in "Studies on hysteria, 1895". *Scandinavian Psychoanalytic Review*, 2 (5).
- Andkjær Olsen, Ole, and Køppe, Simo. (1988). *Freud's theory of psychoanalysis*. New York: New York University Press.
- André, Jacques. (1994). *Sur la sexualité féminine*. Paris, Presses Universitaires de France.
- Andreas-Salomé, Lou. (1962 [1921]). The Dual Orientation of Narcissism. *Psychoanalytic Quarterly* 31.
- . (1964). *The Freud journal of Lou Andreas-Salomé* (Stanley Leavy, Trans.). New York: Basic Books. (Original work published 1958)
- . (1983). *Open letter to Freud*. Paris: Lieu Commun.
- . (1990). *Das "zweideutige" Lächeln der Erotik. Texte zur Psychoanalyse*. Freiburg, Germany: Kore.
- . (1991). *Looking back: memoirs* (Ernst Pfeffer, Ed.; Breon Mitchell, Trans.). Memoirs, New York: Paragon House. (Original work published 1951)
- Angelergues, René (1993). *L'Homme psychique*. Paris: Calmann-Levy.
- Angelini, Alberto. (1988). *La psicanalisi in Russia: dai precursori ali anni trenta*. Naples: Liguori Editore.
- Anthony, E., and Benedek, T. (Eds.). (1970). *Parent-hood: Its psychology and psychopathology*. Boston: Little, Brown.
- Anzieu, Annie. (1989). De la chair au verbe. In *Psychanalyse et Langage: Du corps à la parole* (pp. 103–127). Paris: Dunod. (Original work published 1977)
- Anzieu, Didier. (1956). *Le psychodrame analytique chez l'enfant*. Paris: Presses Universitaires de France.
- . (1959). *L'autoanalyse*. Paris: Presses Universitaires de France.
- . (1970). Freud et la mythologie. *Nouvelle revue de psychanalyse*, 2, 114–145.
- . (1971). L'illusion groupale. *Nouvelle Revue de Psychanalyse*, 4, 37–93.
- . (1974). Le moi-peau. *Nouvelle revue de psychanalyse*, 9, 195–208.
- . (1974). Vers une métapsychologie de la création. In Didier Anzieu (Ed.), *Psychanalyse du génie créateur* (pp. 1–30). Paris: Dunod.

- . (1975). *The group and the unconscious*. (Benjamin Kilborne, Trans.). London and Boston: Routledge & Kegan Paul, 1984.
- . (1975). Le transfert paradoxal. *Nouvelle revue de Psychanalyse*, 12, 49–72.
- . (1979). The sound image of the self. *International Review of Psycho-Analysis*, 6 (1), 23–36.
- . (1981). *Le corps de l'œuvre, essais psychanalytiques sur le travail créateur*. Paris: Gallimard.
- . (1984). *The group and the unconscious*. (Benjamin Kilborne, Trans.). London and Boston: Routledge & Kegan Paul. (Original work published 1975)
- . (1984). Les groupes et leurs romans des origines. In Didier Anzieu, Bertrand Cramer, Georges David, et al., *Le nouveau roman familial, ou "On te le dira quand tu seras plus grand"* (pp. 99–109). Paris: E.S.F.
- . (1986). *Freud's self-analysis* (Peter Graham, Trans.). Madison, CT: International Universities Press. (Original work published 1975.)
- . (1986). Some alterations of the ego which make analyses interminable. *International Journal of Psychoanalysis*, 68 (1), 9–20.
- . (1989). *The skin ego* (Chris Turner, Trans.). New Haven, CT: Yale University Press. (Original work published 1985)
- . (1989). Beckett and Bion (Juliet Mitchell, Trans.). *International Review of Psycho-Analysis*, 16 (2), 163–170.
- . (1990). Formal signifiers and the ego-skin. In Didier Anzieu et al. (Eds.), *Psychic envelopes* (Daphne Briggs, Trans.). London: Karnac Books. (Original work published 1987)
- . (1994). *Le Penser. Du Moi-peau au Moi-pensant*. Paris: Dunod.
- . (1996). *Créer, détruire*. Paris: Dunod.
- Anzieu, Didier, and Chabert, Catherine. (1997). *Les méthodes projectives*. Paris: Presses Universitaires de France.
- Appignanesi, Lisa, and Forrester, John. (1992). *Freud's women*. New York: Basic Books.
- Applegarth, Adrienne. (1971). Comments on aspects of the theory of psychic energy. *Journal of the American Psychoanalytic Association*, 19, 379–416.
- Arbiser, Samuel. (1978). Un modelo de psicoterapia grupal. Los aportes de Pichon-Rivière. *Revista de Psicoanálisis de la Asociación Psicoanalítica Argentina*, 35, 4, 821–839.
- . (1985). El grupo interno. Reflexiones acerca de la relación entre la red intrapsíquica e interpersonal psicoanálisis. *Asociación Psicoanalítica de Buenos Aires*, 7, 3, 389–415.
- Arendt, Hannah. (1951). *The origins of totalitarianism*. New York: Harcourt, Brace & World.
- Arfouilloux, Jean-Claude. (1989). La formation dans la S.F.P. et dans l'A.P.F. Malaise dans la culture analytique. *Revue internationale d'histoire de la psychanalyse*, 2, 343–368.
- Ariès, Philippe. (1962). *Centuries of childhood: A social history of family life* (Robert Baldick, Trans.). New York: Vintage Books. (Original work published 1960)
- Arieti, Silvano. (1955). *The interpretation of schizophrenia*. New York: Brunner.
- Arlow, Jacob A. (1953). Masturbation and symptom formation. *Journal of the American Psychoanalytic Association*, 1, 45–58.
- . (1955). Notes on oral symbolism. *Psychoanalytic Quarterly*, 24, 63–74.
- . (1961). Ego psychology and the study of mythology. *Journal of the American Psychoanalytic Association* 9, 371–393.
- . (1962). Conflict, regression and symptom formation. *International Journal of Psychoanalysis* 44, 12–22.
- . (1964). Symptom formation and character formation. *International Journal of Psychoanalysis*, 45, 167–170.
- . (1969). Fantasy, memory, and reality testing. *Psychoanalytic Quarterly*, 38, 28–51.
- . (1969). Unconscious fantasy and disturbances of conscious experience. *Psychoanalytic Quarterly* 38, 1–17.
- . (1979). The genesis of interpretation. *Journal of the American Psychoanalytic Association*, Supplement, 27, 193–206.
- . (1980). The revenge motive in the primal scene. *Journal of the American Psychoanalytic Association*, 28, 519–542.
- . (1982). Problems of the superego concept. *Psychoanalytic Study of the Child*, 37, 229–244.
- . (1982). Scientific cosmogony, mythology, and immortality. *Psychoanalytic Quarterly*, 51, 177–195.
- . (1996). The concept of psychic reality—how useful, *International Journal of Psychoanalysis*, 77, 659–666.
- Arlow, Jacob A., rep. (1955). Panel: sublimation. *Journal of the American Psychoanalytic Association*, 3, 515–527.

- Arlow, Jacob A., and Brenner, Charles. (1964). *Psychoanalytic concepts and the structural theory*. New York: International Universities Press.
- Aron, Lewis. (1995). The internalized primal scene. *Psychoanalytic Dialogues*, 5, 195–238.
- Aronson, Joyce K. (ed.). (1993). *Insights in the dynamic psychotherapy of anorexia and bulimia: An introduction to the literature*, Northvale, NJ: Jason Aronson.
- Arrivé, Michel. (1994). *Langage et psychanalyse, linguistique et inconscient: Freud, Saussure, Pichon, Lacan*. Paris: Presses Universitaires de France.
- Arrué, Omar (1991). Origenes e identidad del movimiento psicoanalítico chileno. In E. Casaula, J. Coloma, and J.-F. Jordán (Eds.), *Cuarenta Años de psicoanálisis en Chile*. Santiago: Ananké.
- . (1988). Cuarenta años de psicoanálisis en Chile. *Revista chilena de psicoanálisis*, 7 (1), 3–5.
- Artières, Michel. (1995). *Cézanne ou l'inconscient maître d'œuvre*. Lausanne: Delachaux and Niestlé.
- Ascher, Jacques, and Weiss, Daniel. (1997). De l'un à l'autre. La psychanalyse est-elle une histoire goy? *Revue Internationale de psychanalyse*, 6, 109–124.
- Association des centres psychopédagogiques. (1954). *Rapport sur l'activité des premiers centres psychopédagogiques à Paris (Claude-Bernard), Strasbourg et Mulhouse*. Paris: Association des centres psychopédagogiques.
- Association française pour la sauvegarde de l'enfance et de l'adolescence. (1959, May–June). Problème d'un centre médico-psychologique: l'institut Claparède. *Sauvegarde de l'enfance*, 5–6.
- . (1989, May–June). Travaux de l'institut Claparède: quarante ans d'existence. *Sauvegarde de l'enfance*, 3.
- Assoun, Paul Laurent. (1982). L'archaïque chez Freud: entre Logos et Anankè. *Nouvell revue de psychanalyse*, 26, 11–44.
- . (1976). *Freud, la philosophie et les philosophes*. Paris: Presses Universitaires de France.
- . (1981). *Introduction à l'épistémologie freudienne*. Paris: Payot.
- . (1995). *Portrait métapsychologique de la haine: Du symptôme au lien social*. Paris: Anthropos.
- . (1997). *Psychanalyse*. Paris: Presses Universitaires de France.
- Athanassiou, Cléopâtre. (1997). *Bion et la Naissance de l'espace psychique*. Paris: Popesco.
- Atwood, George E., and Stolorow, Robert D. (1980). Psychoanalytic concepts and the representational world. *Psychoanalysis and Contemporary Thought*, 3, 267–290.
- . (1984). *Structures of subjectivity: explorations in psychoanalytic phenomenology*. Hillsdale, NJ: The Analytic Press.
- Aubert-Godart, Anne. (1998). Entre adulte et bébé, l'étrange désordre de la naissance. In *Le bébé, l'intime et l'étrange*. Paris: Érès.
- Aubry Weiss, Jenny. (1983). *Enfance abandonnée*. Paris: Scarabée-Métallier.
- Auchincloss, Elizabeth L., and Weiss, Richard W. (1992). Paranoid character and the intolerance of indifference. *Journal of the American Psychoanalytic Association*, 40, 1013–1038.
- Auge, Marc. (1989). *Le Père. Métaphore paternelle et fonction du père: l'interdit, la filiation, la transmission*. Paris: Denoël.
- Aulagnier, Paula. (1979). *Les Destins du plaisir. Aliénation, amour, passion*. Paris, Presses Universitaires de France.
- . (1967). Le désir de savoir dans ses rapports à la transgression. *L'Inconscient 1*; republished in *Un interprète en quête de sens*. Paris: Ramsay, 1986.
- . (1979). *Les destins du plaisir. Aliénation, amour, passion*. Paris: Presses Universitaires de France.
- . (1979). *Les destins du plaisir: Aliénation, amour, passion*. Paris: Presses Universitaires de France.
- . (1980). Du langage pictural au langage de l'interprète. *Topique*, 26, 29–54.
- . (1984). *L'Apprenti-historien et le Maître-sorcier. Du discours identifiant au discours délirant*. (The apprentice historian and the master sorcerer: From the discourse of identification to the discourse of delusion). Paris: Presses Universitaires de France.
- . (1986). *Un interprète en quête de sens*. Paris: Ramsay.
- . (1986). Demande et identification. In *Un interprète en quête de sens*. Paris: Ramsay. (Original work published 1968)
- . (1991). *Un interprète en quête de sens* Paris: Payot.
- . (1992 [1990]). Voies d'entrée dans la psychose. [Ways of Entering the World of Psychosis]. *Topique*, 49, 7–29.
- . (2001). *The violence of interpretation: from pictogram to statement* (Alan Sheridan, Trans.). Hove, East Sussex, and Philadelphia: Brunner Routledge. (Original work published 1975)
- Aulagnier-Spairani, Piera, et al. (1967). *Le désir et la perversion*. Paris: Seuil.

- Avenburg, Ricardo. (1996). Enrique Pichon-Rivière, sus enseñanzas a la luz de mi vínculo con Al. *Actualidad Psicológica*, 21, 231, 12–14.
- Aziz, Robert. (1990). *C. G. Jung's psychology of religion and synchronicity*. Albany: State University of New York Press.
- Bärmark, Jan, and Nilsson, Ingemar. (1983). *Poul Bjerre, "Människosonen."* Stockholm: Natur och Kultur.
- Bégoïn, Jean. L'être, l'espace et le temps: les travaux de D. Meltzer sur l'autisme (1975). In Roger Perron and Denys Ribas (Eds.), *Autismes de l'enfance* (pp. 91–114). Paris: Presses Universitaires de France.
- Bérillon, Edgar. (1889). *Premier Congrès international de l'hypnotisme expérimental et thérapeutique*. Paris: Doin.
- Bach, Helmut. (1970). Die Behandlungstechnik in den neopsychoanalytischen Richtungen. In *Lerbuch der Klinischen Psychologie* (W. J. Schraml, Ed.). Bern: Hans Huber.
- Bach, Sheldon. (1994). *The Language of Perversion and the Language of Love*. Northvale, NJ: Jason Aronson.
- . (2001). On being forgotten and forgetting one's self. *Psychoanalytic Quarterly*, 70, 739–756.
- Bachelard, Gaston. (1938). *La Formation de l'esprit scientifique: Contribution à une psychanalyse de la connaissance objective*. Paris: Vrin.
- . (1964). *The psychoanalysis of fire*. (Alan C. M. Ross, Trans.). Boston: Beacon Press. (Original work published in 1938)
- . (1968). *The philosophy of no; a philosophy of the new scientific mind*. (G. C. Waterston, Trans.). New York: Orion Press. (Original work published in 1940)
- . (1969). *The flame of a candle*. (Joni Caldwell, Trans.). Dallas, TX: Dallas Institute Publications.
- . (1972). *L'Engagement rationaliste*. Paris: Presses Universitaires de France.
- Bahr, Hermann. (1906). *Die Andere*. Frankfurt am Main: S. Fischer.
- Bak, Robert. (1941). Temperamentur-Orientierung und Überfließen der Ichgrenzen in der Schizophrenie. *Schweizer Archiv für Neurologie, Neurochirurgie und Psychiatrie*, 46, 158–177.
- . (1953). Fetishism. *Journal of the American Psychoanalytical Association*, 1–2, 285–297.
- . (1956). Aggression and perversion. In Sándor Lorand (Ed.), *Perversions: psychodynamics and therapy* (pp. 231–240). New York: Random House.
- . (1968). The phallic woman: the ubiquitous fantasy. *Psychoanalytic Study of the Child*, 23, 16–36.
- . (1973). Being in love and object loss. *International Journal of Psychoanalysis*, 54, 1–8.
- Bakan, David. (1958). *Sigmund Freud and the Jewish mystical tradition*. Princeton, NJ: Van Nostrand.
- Balbo, Gabriel and Bergès, Jean. (1996). *L'Enfant et la psychanalyse*. Paris: Masson.
- Balier, Claude. (1988). *Psychanalyse des comportements violents*. Paris: Presses Universitaires de France.
- Balint, Alice. "Love for the mother and Mother Love." In Michael Balint, *Primary love and psycho-analytic technique*. London: Tavistock Publications, 1965.
- . (1953). *The psycho-analysis of the nursery*. London: Routledge & Kegan Paul. (Original work published 1932)
- . (1990). *Anya és gyermek (Mother and child)*. (2nd ed.). Budapest: Pantheon.
- Balint, Michael. (1952). Character analysis and new Beginning. In his *Primary love and psychoanalytic technique*. London: Hogarth. (Original work published 1932)
- . (1952). *Primary love and psycho-analytic technique*. London: Hogarth.
- . (1954). Analytic training and training analysis. *International Journal of Psychoanalysis*, 35, 157–162.
- . (1957). *The Doctor, His Patient, and the Illness*. New York: International Universities Press.
- . (1958). The three areas of the mind. Theoretical considerations. *International Journal of Psychoanalysis*, 9, 328–340.
- . (1959). *Thrills and regressions*. New York: International Universities Press.
- . (1964). *The doctor, his patient, and the illness* (2nd ed.). London: Pitman Medical Publishing. (1st edition published 1957)
- . (1965). *Critical notes on the theory of the pregenital organizations of the libido. Primary love and psycho-analytic technique*. New York: Liveright. (Original work published 1935)
- . (1967). Introduction. In Ferenczi, *Oeuvres Complètes* (Vol. 4). Paris: Payot, 1982.
- . (1968). *The basic fault. Therapeutic aspects of regression*. London: Tavistock Publications.
- . (1972). L'amour génital. *Amour primaire et Technique psychanalytique*. Paris: Payot. (Original work published 1947)
- Balint, Michael, and Balint, Enid. (1961). *Psychotherapeutic techniques in medicine*. London: Tavistock.
- Balint, Michael, Balint, Enid, Gosling, Robert, and Hildebrand, H. Peter. (1979). *Le médecin en formation: La*



- sélection et l'évaluation des résultats dans un programme de formation destiné à des médecins de famille*. Paris: Payot. (Original work published 1966)
- Balmory, Marie. (1982). *Psychoanalyzing psychoanalysis: Freud and the hidden fault of the father* (Ned Lukacher, Trans.). Baltimore: Johns Hopkins University Press. (Original work published 1979)
- Baranès, Jean-José. (1990). Être à la fois mémoire et provocateur. In Société psychanalytique de Paris (Ed.), *La psychanalyse: Questions pour demain*. Paris: Presses Universitaires de France.
- Barande, Ilse. (1977). *Le maternel singulier: Freud et Léonard de Vinci*. Paris: Aubier-Montaigne.
- Barande, Ilse, and Daymas, Simone. (1994). Pierre Mâle et nous. *Perspectives psychiatriques*, 41, 17–23.
- Barande, Robert. (1989). *Parcours d'un psychanalyste, son esthétique et son éthique*. Paris: Pro-Edi.
- Baranger, Madeleine, Baranger, Willy, and Mom, Jorge M. (1983). Process and non-process in analytic work. *International Journal of Psychoanalysis*, 64, 1983, p. 1–15. (Original work published 1982)
- . (1990). Obituario: Luisa Gambier de Alvarez de Toledo. *Revista de psicoanálisis de la Asociación psicoanalítica argentina*, XLVII (3), 410–413.
- Baranger, Willy. (1971). *Posición y objeto en la obra de Melanie Klein*. Buenos Aires: Kargieman.
- Baranger, Willy, and Baranger, Madeleine. (1969). *Problemas del campo psicoanalítico*. Buenos Aires: Kargieman.
- Barchilon, Jose. (2000). Darwin revisited: the phylogeny of emotions. *International Journal of Psychoanalysis*, 81, 328–330.
- Bareuther, Herbert et al. (1989). *Forschen und Heilen. Auf dem Weg zu einer psychoanalytischen Hochschule, Beiträge aus Anlass des 25 jährigen Bestehens des Sigmund-Freud Instituts*. Frankfurt: Suhrkamp.
- Bargues, René. (1964). Les nourrices d'un placement familial curatif des carences affectives graves de la première enfance. *Évolution psychiatrique*, 3.
- Barrau, Bernard. (1989). Bégaiement et violence orale. In *Psychanalyse et langage: Du corps à la parole*. Paris: Dunod. (Original work published 1977)
- Barrois, Claude. (1988). *Les névroses traumatiques*. Paris: Dunod.
- Barron, James W., Eagle, Morris N., and Wolitzky, David L. (eds.). (1992). *Interface of psychoanalysis and psychology*. Washington, DC: American Psychological.
- Barron, James W., et al. (1993). *Self-analysis*. Hillsdale, NJ, and London: The Analytic Press.
- Barrucand, Dominique (1967). *Histoire de l'hypnose en France*. Paris: Presses Universitaires de France.
- Barthes, Roland. (1970). *Mythologies*. Paris: Seuil.
- Bass, Alan. (1994). Aspects of urethrality in women. *Psychoanalytic Quarterly*, 63, 491–517.
- . (2001). *Difference and disavowal*. Palo Alto: Stanford University Press.
- Bataille, Laurence. (1985). D'une pratique. *Études Freudiennes*, 25, 7–30.
- Bateson, Gregory, et al. (1951). *Communication: The Social Matrix of Psychiatry*, New York: W. W. Norton.
- Bateson, Gregory, Jackson, Don D., Haley, Jay, and Weakland, John (1956). Toward a theory of schizophrenia. *Behavioral Science*, 1, 251–254.
- Bateson, Gregory, and Mead, Margaret. (1942). *Balinese character: a photographic analysis*. New York: New York Academy of Sciences.
- Bauchau, Henry. (1984). La connivence des temps. *Études Freudiennes*, 23, 9–20.
- Baudouin, Charles. (1920). *Suggestion et autosuggestion*. Neuchâtel–Paris: Delachaux and Niestlé.
- . (1924). *Qu'est-ce que la suggestion? Introduction à la psychologie de la suggestion et de l'autosuggestion*. Neuchâtel–Paris: Delachaux & Niestlé.
- . (1931). *L'Âme enfantine et la psychanalyse*. Neuchâtel–Paris: Delachaux and Niestlé.
- . (1957). *Psychanalyse du symbole religieux*. Paris: Fayard.
- . (1962). Suggestion and autosuggestion, a psychological and pedagogical study based upon the investigations made by the new Nancy school (Eden and Cedar Paul, Trans.). London: G. Allen & Unwin. (Original work published 1920)
- Baudry, Francis. (1984). Essay on method in applied psychoanalysis. *Psychoanalytic Quarterly*, 53, 551–581.
- Bauduin, Andrée. (1985). L'asthme bronchique, aspects dynamiques et psychanalytiques. *Revue médicale de Liège*, 90 (22).
- . (1987). Du préconscient. *Revue française de psychanalyse*, 51, 449–538.
- Bayle, Gérard. (1997). *Paul-Claude Racamier*. Paris: Presses Universitaires de France.
- . (1997). Considérations sur la clinique des phobies névrotiques. In *Peurs et Phobies*. (p. 113–133). Paris: Presses Universitaires de France.
- Beard, George. (1879). *Neurasthenia as a cause of inebriety*. New York: E. B. Treat.
- Beard, George. (1881). *American nervousness: its causes and consequences*. New York: E. B. Treat.

- . (1884). *Sexual neurasthenia (nervous exhaustion), its hygiene, causes, symptoms and treatment*. New York: E. B. Treat.
- Beauvoir, Simone de. (1965). *Force of circumstance: The autobiography of Simone de Beauvoir*. (Richard Howard, Trans.). New York: Putnam. (Original work published 1963)
- Becker, E. (1961). A note on Freud's primal horde theory. *Psychoanalytic Quarterly*, 30, 413–419.
- Becker, Mitchel, Shalgi, Boaz. (2002). A psychoanalytical approach to integrating family and individual therapy in the treatment of adolescents: a case study. *Psychoanal. Study of the Child*, 57, 203–217.
- Becker, Philip L. (1966). Edward Hirschmann, 1871–1957, Psychoanalysis of great men. In Franz Alexander, Samuel Eisenstein and Martin Grotjahn (Eds.), *Psychoanalytic Pioneers*. New York: Basic Books Inc.
- Becker, Ted. (1974). On latency. *Psychoanalytic Study of the Child*, 29, 3–12.
- Beirnaert, Louis. (1966). *Expérience chrétienne et psychologie*. Paris: L'Épi [1984].
- . (1986). *Aux frontières de l'acte analytique*. Paris: Le Seuil.
- Bellak, Leopold; Hurvich, Marvin, and Gediman, Helen. (1973). *Ego functions in schizophrenics, neurotics and normals. A systematic study of conceptual, diagnostic and therapeutic aspects*. New York: Wiley, 572 p.
- Bellanova, Piero, and Bellanova, A. (1982). *Le due gradive*. Roma: C.E.P.I.
- Bellour, Raymond. (1979). *The analysis of film* (Constance Penley, Ed.). Bloomington: Indiana University Press, 2000.
- Benassy, Maurice. (1969). Le moi et ses mécanismes de défense: Étude théorique. In *La théorie psychanalytique*. Paris: Presses Universitaires de France.
- Benayoun, Robert. (1965). Interview de John Huston. *Positif*, 70.
- Benedek, Therese. (1949). The psychosomatic implications of the primary unit: mother–child. *American Journal of Orthopsychiatry*, 19, 642–654.
- . (1956). Psychobiological aspects of mothering. *American Journal of Orthopsychiatry*, 26, 272.
- . (1959). Parenthood as a developmental phase. *Journal of the American Psychoanalytic Association*, 7, 389–417.
- . (1959). Parenthood as a developmental phase. *Journal of the American Psychoanalytic Association*, 7, 389–417.
- . (1973). *Psychoanalytic investigations: Selected papers*. New York: Quadrangle Books.
- . (1977). Ambivalence, passion and love. *Journal of the American Psychoanalytic Association*, 25, 53–80.
- Benedict, Ruth. (1935). *Patterns of culture*. London: Routledge.
- Benjamin, Harry. (1953). Transvestism and transsexualism international. *Journal of Sexology*, 7, 1, 12–14.
- Benjamin, Jessica. (1998). *Shadow of the other. Inter-subjectivity and gender in psychoanalysis*. New York: Routledge.
- Bennani, Jalil. (1996). *La psychanalyse au pays des saints*. Casablanca, Morocco: Fennec.
- Benslama, Fethi. (1988). *La nuit brisée*. Paris: Ramsay.
- Berdondini, Nadine. (1987). *L'introduction de la psychanalyse en Belgique: 1900–1947*. Louvain-la-Neuve, reprinted 1995.
- Beres, David. (1965). Structure and function in psycho-analysis. *International Journal of Psychoanalysis*, 46, 53–63.
- Berge, André. (1936). *L'éducation familiale*. Paris: Montaigne.
- . (1968). *Les psychothérapies*. Paris: Presses Universitaires de France.
- . (1970). *L'enfant au caractère difficile*. Paris: Hachette.
- . (1975). Nécrologie de Margaret Clark Williams. *Revue française de psychanalyse*, 39 (4), 669–670.
- . (1988). *De l'écriture à la psychanalyse, entretiens avec M. Mathieu*. Paris: Clancier-Guénaud.
- . (1995). *André Berge: écrivain, psychanalyste, éducateur*. Paris: Desclée de Brouwer.
- Berger, Maurice. (1986). *Entretiens familiaux et Champ transitionnel*. Paris: Presses Universitaires de France.
- . (1995). *Le travail thérapeutique avec les familles*. Paris: Dunod.
- Bergeret, Jean. (1973). Pour une métapsychologie de l'humour. *Revue française de psychanalyse*, 37, 4.
- . (1975). *La dépression et les états limites*. Paris: Payot.
- . (1976). Personnalités normales et pathologiques: Les structures mentales, le caractère, les symptômes. *Revue française de psychanalyse*, 40 (2), 351–370.
- . (1984). *La violence fondamentale*. Paris: Dunod.
- . (1994). *La violence et la vie*. Paris: Payot.
- . (1996). *La pathologie narcissique*. Paris: Dunod.

- . (2002). *Le passage à l'acte de l'état limite*.
- Bergler, Edmund. (1949). *The basic neurosis—oral regression and psychic masochism*. New York: Grune and Stratton.
- . (1969). *Selected papers of Edmund Bergler, M.D., 1933–1961*. New York: Grune and Stratton.
- . (1982). *Counterfeit-sex*. New York: Grune and Stratton.
- . (1989). *The superego*. Madison, WI: International Universities Press.
- . (1992). *Principles of self-damage*. Madison, WI: International Universities Press.
- . (1993). *Curable and incurable neurotics*. Madison, WI: International Universities Press.
- Bergman, Anni. (2002). Changing psychoanalytic psychotherapy into psychoanalysis. *International Journal of Psychoanalysis*, 83, 245–248.
- Bergmann, Martin S. (1963). The place of Paul Federn's ego psychology in psychoanalytic metapsychology. *Journal of the American Psychoanalytic Association*, 11, 97–116.
- Bergmann, Martin S., and Hartman, Frank. (1976). *The Evolution of Psychoanalytic Technique*. New York: Basic books.
- Bergson, Henri. (1896). *Matter and memory*. New York: Zone Books, 1988.
- Berman, E. (2002). Identifying with the other, a conflictual vital necessity. *Psychoanalytic Dialogues*, 12, 141–152.
- Bermejo, Frijole V. (1993). La institucionalización del psicoanálisis en España en el marco de la A.P.I. Doctoral thesis, faculty of psychology, University of Valencia.
- Bernard, Walter. (1946). Freud and Spinoza. *Psychiatry*, 5, 99–108.
- Bernays-Freud, Anna. (November 1940). My brother Sigmund Freud. *American Mercury* 51 (203), 335–342.
- Bernays-Heller, Judith. (1973). Freud's mother and father. In H.M. Ruitenbeck, Ed., *Freud as we knew him* (pp. 334–340). Detroit: Wayne University Press.
- Berner, Wolfgang. (1992). The Viennese Psychoanalytic Society after 1945, I. Ed. Peter Kutter. *Psychoanalysis International*, 1. Europe. Stuttgart-Bad Cannstadt: Frommann-Holzboog.
- Bernfeld, Siegfried. (1921). *Kinderheim Baumgarten. Bericht über einen ernsthaften Versuch mit neuer Erziehung*. Berlin: Jüdischer Verlag.
- . (1925). *Sisyphos, oder die Grenzen der Erziehung*. Vienna: Internationaler psychoanalytischer Verlag.
- . (1929). *The psychology of the infant*. New York: Brentano.
- . (1932). Der Begriff der “Deutung” in der Psychoanalyse. *Zeitschrift für angewandte Psychologie*, 4, 448–497.
- . (1949). Freud's scientific beginnings. *American Imago*, 6, 163–196.
- . (1984). Über die psychoanalytische Ausbildung. *Psyche*, 38, 437–459.
- Bernfeld, Siegfried, and Cassirer-Bernfeld, Suzanne. (1944). Freud's Early Childhood. *Bulletin of the Menninger Clinic*, VIII, pp. 107–115.
- Bernfeld-Cassirer, Suzanne. (1951). Freud and archaeology. *American Imago*, 8, 107–128.
- Bernheim, Hippolyte. (1995). *Hypnotisme, suggestion, psychothérapie* (2nd ed). Paris: Fayard. (Original work published 1903)
- Bernstein, Isidore. (1983). Masochistic pathology and feminine development. *Journal of the American Psychoanalytic Association*, 31, 467–486.
- Bertalanffy, Ludwig von. (1973). *General system theory: Foundations, development, applications*. New York: G. Braziller. (Original work published 1947)
- Berthelsen, Detlef. (1989). *Alltag bei Familie Freud. Die Erinnerungen der Paula Fichtl*. Hamburg: Hoffman & Campe.
- Bertin, Célia. (1982). *Marie Bonaparte, a life*. New York: Harcourt Brace Jovanovich.
- . (1982). *Marie Bonaparte, a life*. New York: Harcourt Brace Jovanovich.
- Bertrand, Michèle. (1984). *Spinoza et l'imaginaire*. Paris: Presses Universitaires de France.
- Bertrand, Michèle, and Doray, Bernard. (1989). *Psychoanalyse et Sciences sociales*. Paris: La Découverte.
- Besançon, Alain. (1974). *L'histoire psychanalytique: Une anthologie*. Paris: Mouton.
- Besançon, Guy. (1977). Le corps présent, réflexions sur une série de recto-colites hémorragiques. *Revue française de psychosomatique*, 19 (2).
- Besserman-Vianna, Helena. (1995). *N'en parlez à personne. La psychoanalyse face à la dictature et à la torture*. Paris: Éditions l'Harmattan.
- . (1997). *Politique de la psychoanalyse face à la dictature et à la torture. N'en parlez à personne*. Paris: L'Harmattan.
- Bettelheim, Bruno. (1943). Individual and mass behavior in extreme situations. *Journal of Abnormal and Social Psychology*, 38, 417–452.

- Bettelheim, Bruno. (1950). *Love is not enough*. New York: Free Press.
- . (1960). *The informed heart: Autonomy in a mass age*. New York: Alfred A. Knopf.
- . (1967). *The empty fortress: infantile autism and the birth of the self*. New York: Free Press.
- . (1980). *Surviving and other essays*. New York: Vintage.
- . (1983). *Freud and man's soul*. New York: Alfred A. Knopf.
- . (1990). *Freud's Vienna and other essays*. New York: Alfred A. Knopf.
- . (1997). *The uses of enchantment: the meaning and Importance of fairy tales*. New York: Vintage.
- Bertrand, Michèle, and Doray, Bernard. (1989). *Psychanalyse et Sciences sociales*. Paris: La Découverte.
- Bibring, Edward. (1936). Zur entwicklung und problematik der triebtheorie. *Imago*, 22, 147–176.
- . (1937). Contribution to the symposium on the theory of the therapeutic results of psycho-analysis. *International Journal of Psychoanalysis*, 18, 170–189.
- Bibring, Grete. (Ed.). (1951). Report on the 17th International Psychoanalytical Congress. *International Journal of Psychoanalysis*, 33, 249–251.
- Bibring-Lehner, Grete. (1933). “Über die phallische Phase und ihre Störungen beim Mädchen.” *Zeitschrift für psychoanalytische Pädagogik*, 7, 145–152.
- Bick, Esther. (1964). Notes on infant observation in psycho-analytic training. *International Journal of Psychoanalysis*, 45, 558–566.
- . (1968). The experience of the skin in early object relations. *International Journal of Psychoanalysis*, 49, 558–566.
- . (1986). Further considerations on the functioning of skin in early object relations: findings from infant observation integrated into child and adult analysis. *British Journal of Psychotherapy*, 2, 292–299.
- Bicudo, Virginia L. (1948). Contribuição para a história do desenvolvimento da psicanálise em São Paulo. *Arquivos de neuropsiquiatria*, 6, 1.
- Bieber, Irving, et al. (1962). *Homosexuality, a psycho-analytical study*. New York: Basic Books.
- Bigras, Julien. (1977). *L'enfant dans le grenier*. Paris: Hachette.
- . (1979). *La folie en face*. Paris: Robert Laffont.
- . (1979). *Le psychanalyste nu*. Paris: Robert Laffont.
- . (1980). *Kati of course*. Paris: Mazarine.
- . (1983). *Ma vie, ma folie*. Paris-Montréal: Mazarine-Boréal Express.
- Billinsky, John M. (1969). Jung and Freud: The end of a romance. *Andover Newton Quarterly*, 62, 2, 39–43.
- Binet, Agnes. (1977). Comportement d'attachement ou instinct de cramponnement? *Psychiatrie de l'enfant*, 20, 533–564.
- . (1984). Útbaigazítás. In Hermann (Ed.): *Az ember ő si ösztönei* (pp. 15–33). Budapest: Magvető.
- Binet, Alfred, and Féré, Charles. (1887). *Animal magnetism*. New York, D. Appleton and Company.
- Binswanger, Ludwig. (1920). Psycho-analysis and clinical psychiatry. *International Journal of Psychoanalysis*, 1 (3), 357.
- . (1953). *Grundformen und Erkenntnis menschlichen Daseins* (2nd ed.). Zurich, Switzerland: Niehans.
- . (1957). *Sigmund Freud: Reminiscences of a friendship* (Norbert Guterman, Trans.). New York: Grune & Stratton. (Original work published 1955)
- . (1971). *Introduction à l'analyse existentielle* (Jacqueline Verdeaux and Roland Kuhn, Trans.). Paris: Minuit.
- Bion, Wilfred R. (1957). Differentiation of the psychotic from the non-psychotic personalities. *International Journal of Psychoanalysis*, 38, 3–4. 266–275.
- . (1959). Attacks on linking. *International Journal of Psychoanalysis*, 40 (5–6), p. 308.
- . (1961). *Experiences in groups*. London: Tavistock Publications.
- . (1962). *Learning from experience*. London: Heinemann; New York: Basic Books.
- . (1963). *Elements of psycho-analysis*. London, Heinemann.
- . (1965). *Transformations: Change from learning to growth*. London: Heinemann.
- . (1967). *Second thoughts*. London, Heinemann.
- . (1967). A theory of thinking. In *Second thoughts*. London: Heinemann. (Reprinted from *International Journal of Psychoanalysis*, 43, (1962). 4–5.)
- . (1967). On arrogance. In his *Second thoughts* (pp. 87–88). London: Heinemann. (Original work published 1953)
- . (1970). *Attention and interpretation*. London: Tavistock Publications.
- . (1975). *A memoir of the future*. (Vol. I, *The Dream*). Rio de Janeiro: Imago Editora; London: Karnak Books, 1991.

- . (1977). *A memoir of the future*. (Vol. II, *The Past Presented*). Rio de Janeiro: Imago Editora; London: Karnak Books, 1991.
- . (1975). *The grid and Caesura*. Rio de Janeiro: Imago.
- . (1979). *A memoir of the future*. (Vol. III, *The Dawn of Oblivion*). Perth: Clunie Press; London: Karnak Books, 1991.
- Biro, Adam, Passeron, René. (1982). *Dictionnaire général du surréalisme et de ses environs*. Freiberg, Switzerland: Office du Livre.
- Birraux, Annie. (1994). *Éloge de la phobie*. Paris: Presses Universitaires de France.
- . (1994). *L'éloge de la phobie*. Paris: Presses Universitaires de France.
- Blacker, Kay Hill. (1981). Insight (panel). *Journal of the American Psychoanalytic Association*, 29, 659–672.
- Blanton, Smiley. (1971). *Diary of my analysis with Freud*. New York: Hawthorn.
- Blau, Abram. (1952). In support of Freud's syndrome of "actual" anxiety (actual). neurosis. *International Journal of Psychoanalysis*, 33, 363–372.
- Bleandonu, Gérard. (1991). *Les groupes thérapeutiques familiaux et institutionnels*. Paris: Presses Universitaires de France.
- Bleger, José. (1958). *Psicoanalisis y dialectica materialista. Estudio sobre la estructura de psicoanalisis*. Buenos Aires: Paidós.
- . (1966). Psycho-analysis of the psycho-analytic frame. *International Journal of Psychoanalysis*, 48 (4), 511–519.
- . (1967). *Simbiosis y ambigüedad; estudio psicoanalítico*. Buenos Aires: Editorial Paidós.
- . (1967). Psychoanalysis of the psycho-analytic frame. *International Journal of Psychoanalysis*, 48 (4), 511–519.
- . (1981). *Symbiose et ambiguïté: Étude psychanalytique* (A. Morvan, Trans.). Paris: Presses Universitaires de France. (Original work published 1967)
- Bleuler, Eugen. (1892). Zur Auffassung der subcorticalen Aphasien. *Neurologisches Zentralblatt*, 18, 562–563.
- . (1896). Buchanzeige über Breuer-Freuds "Studien über Hysterie." *Münchener medizinische Wochenschrift*, 22, 524–525.
- . (1908). Dr Wilhelm Stekel, Spezialarzt für Psychotherapie in Wien: Nervöse Angstzustände und ihre Behandlung, *Münchener Medizinische Wochenschrift*, 32, 1702–1703.
- . (1910). Die psychoanalyse Freuds. Verteidigung und kritische Bemerkungen. *Jahrbuch für psychoanalytische und psychopathologische Forschungen*, 2, 623–730.
- . (1911). Dementia præcox, oder die Gruppe der Schizophrenien. *Aschaffenburg, Handbuch der Psychiatrie*. Leipzig.
- . (1913). Die Kritik der Freudschen Theorie. *Allgemeine Zeitschrift für Psychiatrie und psychisch gerichtliche Medizin*, 52 (5), 665–718.
- . (1952). *Dementia præcox* (Joseph Zinkin, Trans.). New York: International Universities Press. (Original work published 1911)
- . (1952). *The group of schizophrenias*. (Joseph Zinkin, Trans.). New York: International Universities Press. (Original work published 1911)
- Bleuler, M. (1951). Geschichte des Burghölzli und der psychiatrischen universitätsklinik. *Zürcher Spitalgeschrift*, 2, 377–425.
- Bloch, H. Spencer. (1995). *Adolescent development, psychopathology, and treatment*. Madison, CT: International University Press.
- Bloch, Jean-Richard. (1912). *Lévy: Premier livre de contes*. Paris: Gallimard.
- . (1918). *... et compagnie*. Paris: Gallimard. (Reprinted 1997.)
- . (1931). *A Night in Kurdistan* (Stephen Haden-Guest, Trans.). New York: Simon and Schuster. (Original work published 1925)
- . (1931). *Destin du siècle: Essais pour mieux comprendre son temps*. Paris: Rieder. (Reprinted, Paris: Presses Universitaires de France, 1996.)
- Blomfield, O.H.D. (1986). Psychoanalysis in Australia. *Journal of the International Association for the History of Psychoanalysis*, 2, 9–11.
- Blos, Peter. (1962). *On adolescence: A psychoanalytic interpretation*. New York: The Free Press.
- . (1967). The second individuation process of adolescence. *Psychoanalytic Study of the Child*. p. 162–186.
- . (1974). Berta Bornstein 1899–1971. *Psychoanalytic Study of the Child*, 29, 35–38.
- . (1978). The concept of acting out in relation to the adolescent process. In E. Rexford (Ed.), *A developmental approach to the problem of acting out* (p. 153–174). New York: International Universities Press.
- . (1979). *The adolescent passage: developmental issues*, New York: International Universities Press.
- . (1985). *Son and father*. New York: The Free Press.

- . (1987). L'insoumission au père ou l'effort adolescent pour être masculin. *Adolescence*, 6 (21), 19–31.
- Blowers, G.H. (in press). Bingham Dai, Adolf Storfer, and the tentative beginnings of psychoanalytic culture in China: 1935–1941 *Psychoanalysis and History*, 6 (1), 93–105.
- Blum, Hans. (1985). Superego formation, adolescent transformation, and adult neurosis. *Journal of the American Psychoanalytic Association*, 33, 887–910.
- Blum, Harold P. (1971). On the conception and development of the transference neurosis. *Journal of the American Psychoanalytic Association*, 19, 41–53.
- . (1971). Transference and structure. In Mark Kanzer (Ed.), *The unconscious today: essays in honor of Max Schur*. New York: International Universities Press.
- . (1976). Acting out, the psychoanalytic process, and interpretation. *Annual of Psychoanalysis*, 4, 163–184.
- . (1976). Masochism, the ego ideal, and the psychology of women. *Journal of the American Psychoanalytic Association*, 24, 157–192.
- . (1977). The prototype of preoedipal reconstruction. *Journal of the American Psychoanalytic Association*, 25, 757–786.
- . (1978). Symbolic processes and symbol formation. *International Journal of Psychoanalysis*, 59, 455–472.
- . (1980). Paranoia and beating fantasy: psychoanalytic theory of paranoia. *Journal of the American Psychoanalytic Association*, 28, 331–362.
- . (1983). Splitting of the ego and its relation to parent loss. *Journal of the American Psychoanalytic Association*, 31(S), 301–324.
- . (1986). Countertransference and the theory of technique: discussion. *Journal of the American Psychoanalytic Association*, 34.
- . (1994). Paranoid betrayal and jealousy: the loss and restitution of object constancy. In J. Oldham, S. Bone (Eds.), *Paranoia: new psychoanalytical perspectives*. Madison: International Universities Press, p. 97–114.
- . (1994). The conceptual development of regression. *Psychoanalytic Study of the Child*, 49, 60–76.
- . (1995). Symbolism. In B. Moore and B. Fine (Eds.), *Psychoanalysis. The major concepts*. New Haven: Yale University Press, 149–154.
- Blum, Howard. (1996). Seduction trauma: representation, deferred action, pathogenic development. *Journal of the American Psychoanalytic Association*, 44, 1147–1164.
- Blum, J.-L. (1986). La vie d'Hippolyte Bernheim, 1840–1919. (pp. 103–117). Frénésie.
- Boadella, David. (1973). *Wilhelm Reich, The evolution of his work*. Chicago: Henry Regnery.
- Bodei, Remo. (1991). *Geometrica delle passioni*. Rome: Feltrinelli.
- Boehm, Felix. (1926). Homosexualität und Oedipus-komplex. *Internat. Zeitschrift für Psychoanalyse*, 12.
- Boesky, Dale. (1982). Acting out: a reconsideration of the concept. *International Journal of Psychoanalysis*, 63, 39–56.
- . (1988). The concept of psychic structure. *Journal of the American Psychoanalytic Association*, 36(S), 113–136.
- Bokanowski, Thierry. (1994). Ensuite survient un trouble... Sándor Ferenczi, le transfert négatif et la dépression de transfert. In Bertrand, Michèle, et al. *Ferenczi, patient et psychanalyste* (pp. 9–52). Paris: L'Harmattan.
- Bollas, Christopher. (1989). *The forces of destiny*. London: Free Association Books.
- Bollas, Christopher. (1989, June 26). Obituary: Masud Khan—Portrait of an extraordinary psychoanalytic personality. *The Guardian*, p. 39.
- Bollas, Christopher, Pontalis, Jean-Bertrand, Anzieu, Didier; et al. (1989). In Memoriam Masud Khan, 1924–1989. *Nouvelle revue de psychanalyse*, 40, 333–359.
- Bolzinger, André. (1989). Jalons pour une histoire de la nostalgie. *Bulletin de psychologie*, 389, 310–321.
- . (1991). Portrait psychologique et psychanalyse sauvage. À propos de “Le président T.W. Wilson.” *L'Évolution psychiatrique*, 56, 1, 189–200.
- . (1992). Retour à la nostalgie. *Bulletin de psychologie*, 405, 331–340.
- . (1997). Freud pédiatre et antipédiatre. *Le Coq-Héron*, 146, 61–69.
- Bonaparte, Marie. (1935). Passivity, masochism and femininity. *International Journal of Psychoanalysis*, 16, 325–333.
- . (1949). *The life and works of Edgar Allan Poe, a psycho-analytic interpretation* (John Rodker, Trans.). London: Imago. (Original work published 1933)
- . (1950–53). *Five copy-books*. Translated by Nancy Procter-Gregg. London: Imago.
- . (1951). Introduction à la théorie des instincts; De la prophylaxie infantile des névroses. Paris: Presses Universitaires de France.

- . (1952). *Psychanalyse et anthropologie*. Paris: Presses Universitaires de France.
- . (1952). *Psychanalyse et biologie*. Paris: Presses Universitaires de France.
- . (1953). *Female sexuality* (John Rodker, Trans.). New York: International Universities Press. (Original work published 1951)
- Bonin, Werner F. (1963). *Die grossen Psychologen*. Düsseldorf, Germany: Econ Taschenbuch.
- Bonnafé, Marie. (1994). *Les livres c'est bon pour les bébés*. Paris: Calmann-Lévy.
- Bonnet, Gérard. (1996). *La violence du voir*. Paris: Presses Universitaires de France.
- Bonnet, Marguerite. (1975). *La violence du voir*. Paris: Presses Universitaires de France.
- Bonomi, Carlo. (1994). Why have we ignored Freud the “Paediatrician?” *Cahiers psychiatriques genevois, Special Issue*, 55–99.
- Borel, Adrien. (1934). L'expression de l'ineffable dans les états psychopathiques. *L'Évolution psychiatrique*, 3, 35–53.
- . (1934). La pensée magique dans l'art. *Revue française de psychanalyse*, 7, 1, 66–83.
- . (1935). Les convulsionnaires et le diacre Pâris. *L'Évolution psychiatrique*, 4, 3–24.
- . (1940). La folie de Hitler est-elle celle de l'Allemagne? *Les Nouvelles littéraires*, 6, 1.
- Borel, Adrien, and Cénac, Michel. (1932). L'obsession. *Revue française de psychanalyse*, V(4), 586–648.
- Bornstein, Berta. (1935). Phobia in a two-and-a-half year old child. *Psychoanalytic Quarterly*, 4, 93–119.
- . (1945). Clinical notes on child analysis. *Psychoanalytic Study of the Child*, 1, 151–166.
- . (1951). On latency. *Psychoanalytic Study of the Child*, 6, 279–285.
- . (1953). Masturbation in the latency period. *Psychoanalytic Study of the Child*, 8, 65–78.
- Bos, Jaap. (1992). On the origin of the id (*das Es*). *International Review of Psychoanalysis*, 19, 433–443.
- Bose, Girindrasekhar. (1933). A New Theory of Mental Life. *Indian Journal of Psychology*, 37–157.
- Botella, César, and Botella, Sára. (1982). Sur la carence autoérotique du paranoïaque. *Revue française de psychanalyse*, 46(1), 63–80.
- . (1990). La problématique de la régression formelle de la pensée et de l'hallucinatoire. In *La psychanalyse: Questions pour demain, colloque de la S.P.P.* Unesco, Paris: Presses Universitaires de France.
- . (1992). Névrose traumatique et cohérence psychique. *Revue française de psychosomatique*, 2.
- . (1996). La tendance convergente de la régression narcissique. *Revue française de psychosomatique*, 9, 109–125.
- Botella, César, and Botella, Sára. (2001). *La figurabilité psychique*. Lausanne and Paris: Delachaux & Niestlé.
- Bothorel, Jean. (1989). *Bernard Grasset: vie et passion d'un éditeur*. Paris: Grasset.
- Boucebci, Mahfoud. (1982). *Psychiatrie, société et développement*. Algeria: SNED.
- Bourbaki, Nicolas. (1994). *Elements of the history of mathematics* (John Meldrum, Trans.). Berlin: Springer-Verlag.
- Bourgeron, Jean-Pierre. (1993). *Marie Bonaparte et la psychanalyse à travers ses lettres à René Laforgue et les images de son temps*. Geneva: Champion-Slatkine.
- . (1997). *Marie Bonaparte*. Paris: Presses Universitaires de France.
- Boutonier, Juliette. (1945). *L'Angoisse*. Paris: Presses Universitaires de France.
- . (1955). Séance du 25 janvier 1955 de la Société française de philosophie. In F. Pasche (Ed.). *Métapsychologie et Philosophie*, Paris: Les Belles Lettres.
- Bouvard, Laurent. (1981). La vie et l'œuvre du Dr René Allendy (1889–1942). Medical dissertation, Paris-Val-de-Marne, Créteil School of Medicine.
- Bouveresse, Jacques. (1991). *Philosophie, mythologie et pseudo-science: Wittgenstein lecteur de Freud*. Combas, France: Éclat.
- Bouvet, Maurice. (1967). *Oeuvres psychanalytiques. I, La Relation d'objet: névrose obsessionnelle, dépersonnalisation*. Paris: Payot.
- . (1967). La clinique psychanalytique: la relation d'objet. In his *Œuvres psychanalytiques*, Vol. 1. Paris: Payot.
- . (1968). *Oeuvres psychanalytiques. II, Résistance, transfert*. Paris: Payot.
- Bovet, Pierre. (1913). Un rêve expliqué. *Archives de psychologie*, 13, 380–383.
- Bowlby, John. (1944). Forty-four juvenile thieves: Their characters and home life. *International Journal of Psychoanalysis*, 25, 1–57, 207–228.
- . (1951). *Maternal care and mental health*. Geneva: World Health Organization.
- . (1958). The nature of the child's tie to his mother. *International Journal of Psychoanalysis*, 39, 350–373.
- . (1960). Grief and mourning in infancy and early childhood. *Psychoanalytic Study of the Child*, 15, 9–52.

- . (1961). Separation anxiety: A critical review of the literature. *Journal of Child Psychology and Psychiatry*, 1, 251–69.
- . (1969). *Attachment and loss* (Vol. 1). London: Hogarth Press.
- Boyer, Diane, and Sorensen, Pamela. (1999). Tavistock model of infant observation in neonatal intensive. *Psychoanalytical Inquiry*, 19, 146–159.
- Bräutigam, Walter. (1987). *John Rittmeister: Leben und Sterben*. Ebenhausen bei München: Langewiesche-Brandt.
- Brécourt-Villars, Claudine. (1988). *Yvette Guilbert l'irrespectueuse*. Paris: Plon.
- Brücke, Ernst Wilhelm von. (1873–1874). *Vorlesungen über Physiologie*. Vienna: Wilhelm Braumüller.
- Braatøy, Trygve. (1954). *Fundamentals of psychoanalytic technique*. London: Wiley.
- Brabant-Gerö, Éva. (1993). *Ferenczi et L'école hongroise de psychanalyse*. Paris: L'Harmattan.
- Brainsky, Simon. (1984). *manual de psicologia y psicopatología dinámica fundamentos de psicoanálisis*. Bogotá: Ed. Pluma.
- Braunschweig, Denise, and Fain, Michel. (1975). *La nuit, le jour: Essai psychanalytique sur le fonctionnement mental*. Paris: Presses Universitaires de France.
- Brecht Karen, et al. (1985). "Here life goes on in a most peculiar way": *Psychoanalysis Before and After 1933*. Hamburg: Michael Kellner (1993).
- Breen, Dana. (Ed.). (1993). *The gender conundrum*. London, New York: Routledge
- Brelet, Françoise. (1986). *Fantasme et Situation projective*. Paris: Dunod.
- Brenman-Pick, Irma. (1985). Working through in the counter-transference. *International Journal of Psychoanalysis*, 66, p. 157-166 ; republished in Spillius (Ed.). *Melanie Klein Today 2*, London, Routledge, 1988, p. 34-47.
- Brenner, Charles. (1982). *The mind in conflict*. New York: International Universities Press.
- . (1982). Concept of the superego: a reformulation. *Psychoanalytic Quarterly*, 51, 501–525.
- . (2002). Conflict, compromise formation, and structural theory. *Psychoanalytic Quarterly*, 71, 397–418.
- Brenot, Philippe. (1997). *Éloge de la masturbation (Grain d'orange)*. Cadeilhan, France: Zulma.
- Breton, André. (1988). *Œuvres complètes*. Édition établie par Marguerite Bonnet. Paris: Gallimard, La Pléiade.
- . (1988, 1992). *Œuvres complètes*. (M. Bonnet, Ed.). Paris: Gallimard, La Pléiade.
- Brett, Judith, Gold, Stanley, and Geroe Clara. (1982, September). Psychoanalysis in Australia. *MEANJIN*, 41 (3), 339–357.
- Brett, Judith. (1998). Clara Lazar Geroe. In *Australian Dictionary of Biography*. Melbourne: Melbourne University Press.
- Brette, Françoise. (1988). Le traumatisme et ses théories. *Revue française de psychanalyse*, 52, 6, 1259–84.
- Breuer, Josef. (1986). *Die krisis des Darwinismus und die teleologie. Vortrag, gehalten am 2.5.1902*. Tübingen: Diskord.
- Bria, Pietro, and Durst, Margarete. (1992). Ignacio Matte Blanco (Portrait). In A. Negri (Ed.), *Novecento filosofico e scientifico. Protagonisti* (Vol. 3, pp. 409–443). Marzorati: Milano.
- Brierley, Marjorie. (1932). Some problems of integration in women. *International Journal of Psychoanalysis*, 13, 433–448.
- . (1936). Specific determinants in feminine development. *International Journal of Psychoanalysis*, 17, 163–180.
- . (1951). *Trends in psycho-analysis*. London: Hogarth.
- Bril, Jacques. (1989). *L'affaire Hildebrand, ou le meurtre du fils*. Paris: Presses Universitaires de France.
- Brinkgreve, Christien. (1984). *Psychoanalyse in Nederland. Een vestigingsstrijd*. Amsterdam, Arbeiderspers.
- Briquet, Raul. (1934). *Franco da Rocha e a psicanálise: memórias do Hospital Franco da Rocha*. São Paulo, Brazil: [Au: The publisher is perhaps Oficinas Gráficas do Hospital de Juqueri].
- Britton, Ronald. (1999). Getting in on the act: the hysterical solution. *International Journal of Psychoanalysis*, 80, 1–14.
- Britton, Ronald, Feldman, Michael, and O'Shaughnessy, Edna. (1989). *The Œdipus complex today*. London: Karnac Books.
- Britton, Ronald, Steiner, John. (1994). Interpretation: selected fact or overvalues idea? *International Journal of Psychoanalysis* 75, 1069–1078.
- Brody, Sylvia. (1980). Transitional objects: idealization of a phenomenon. *Psychoanalytic Quarterly*, 49, 561–605.
- Bromberg, William, and Schilder, Paul. (1933). Alcoholic hallucinations—castration and dismembering motives. *International Journal of Psychoanalysis*, 14, 206–224.



- Brome, Vincent. (1982). *Ernest Jones: Freud's alter ego*. London: Caliban Books.
- Brown, Dennis, and Zinkin, Louis. (Eds.). (1994). *The psyche and the social world: developments in group-analytic theory*. London/New York: Routledge.
- Brown, Edward M. (2000). Why Wagner-Jauregg won the Nobel Prize. *History of Psychiatry*, 11, 371–382.
- Browne, William J. (1965). The alcoholic bout as an acting out. *Psychoanalytic Quarterly*, 34, 420–437.
- Brun, Rudolf. (1926). “Experimentelle beiträge zur dynamik und ekonomie des triebkonflikts; biologische parallelen zu Freuds trieblehre.” *Imago*, 12, 147–170.
- . (1936). Sigmund Freuds Leistungen auf dem Gebiet der organischen Neurologie. *Schweizer Archiv für Neurologie, Neurochirurgie*, 37, 200–207.
- . (1951). *General theory of neuroses; twenty-two lectures on the biology, psychoanalysis and psychohygiene of psychosomatic disorders*. (Bernard Miall, Trans.). New York: International Universities Press.
- . (1956). Mein weg zu Freud. *Schweizer Zeitschrift für Psychologie*, 15, 125–130.
- Brunswick, Ruth Mack. (1929). The analysis of a case of paranoia (delusions of jealousy). *Journal of Nervous and Mental Disease*, 70, 1–22; 155–78.
- . (1940). The preoedipal phase of the libido development. *Psychoanalytic Quarterly*, 9, 293–319.
- Brusset, Bernard. (1991). *Psychopathologie de l'anorexie mentale*. Paris: Dunod.
- . (1991). L'or et le cuivre. La psychothérapie peut-elle être et rester psychanalytique? *Revue française de psychanalyse*, 55 (3). (May–June).
- . (1992). *Le Développement libidinal*. Paris: Presses Universitaires de France.
- . (1994). L'enfant, l'infantile et la causalité psychique. *Revue Française de Psychanalyse*, 58, 3, 693.
- . (1998). *Psychopathologie de l'anorexie mentale*. Paris: Dunod.
- Bucci, Wilma. (1997). *Psychoanalysis and cognitive science. A multiple code theory*. New York: Guilford Press.
- . (1997). Symptoms and symbols: a multiple code theory of somatization. *Psychoanalytic Inquiry*, 17, 151–172.
- Buican, Denis. (1987). *Darwin et le darwinisme*. Paris: Presses Universitaires de France.
- Buie, Dan H. (1981). Empathy: its nature and limitation. *Journal of the American Psychoanalytic Association*, 29, 281–307.
- Bulhof, Ilse N. (1983). *Freud en Nederland*. Baarn, Ambo.
- Bullitt, William C. (1919). *The Bullitt mission to Russia*. New York: Huebsch.
- . (1926). *It's not done*. New York: Harcourt, Brace & World.
- . (1946). *The great globe itself*. New York: Scribner's.
- Burbage, Frank, and Chouchan, Nathalie. (1993). Freud et Spinoza: la question de la transformation et le devenir actif du sujet. In Olivier Bloch (Ed.), *Spinoza au XXe siècle* (pp. 525–545). Paris: Presses Universitaires de France.
- Burlingham, Dorothy. (1946). Twins. *Psychoanalytic Study of the Child*, 2, 61–74.
- . (1952). *Twins: A study of three pairs of identical twins*. London: Imago Publishing.
- Burlingham, Michael John. (1989). *The last Tiffany: A biography of Dorothy Tiffany Burlingham*. New York: Atheneum.
- Burnham, Donald. (1978). Orthodoxy and eclecticism in American psychoanalysis: The Washington-Baltimore experience. In J. Quen and E. Carlson (Eds.), *American psychoanalysis: origins and development* (pp. 87–108). New York: Brunner Mazel.
- Burrow, Trigant. (1927). The group method of analysis. *Psychoanalytic Review*, 14, 268–280.
- . (1949). *The neurosis of man: An introduction to the science of human behaviour*. New York: Harcourt, Brace and World.
- Busch, Fred. (1995). Beginning analytic treatment: establishing an analytic frame. *Journal of the American Psychoanalytic Association*, 43, 449–468.
- . (1995). Resistance analysis and object relations theory. *Psychoanalytic Psychology*, 12, 43–54.
- . (2000). What is a deep interpretation? *Journal of the American Psychoanalytic Association*, 48, 237–254.
- Bychowski, Gustav. (1952). *Psychotherapy of psychosis*. New York, London: Grune and Stratton.
- . (1954). On the handling of some schizophrenic defence mechanisms and reaction patterns. *International Journal of Psychoanalysis*, 35, 2, 147–153.
- . (1966). Obsessive compulsive façade in schizophrenia. With commentary by M. Wexler. *International Journal of Psychoanalysis*, 47, 2–3, 189–202.
- . (1967). The archaic object and alienation. *International Journal of Psychoanalysis*, 48, 384–393.
- Bydlowski, Monique. (1978). Les Enfants du désir, le désir d'enfant dans sa relation à l'Inconscient. *Psychanalyse à Université*, IV (13), 59–92.

- . (1997). *La dette de vie : itinéraire psychanalytique de la maternité*. Paris: Presses Universitaires de France.
- Bydlowski, Monique, and Raoul-Duval, Anne. (1978). Un avatar psychique méconnu de la puerpéralité: la névrose traumatique post-obstétricale. *Perspectives psychiatriques*, 68, 321–328.
- Cárcamo, Celes Ernesto. (1948). Quetzalcoatl: le dieu serpent à plumes de la religion maya-aztèque. *Revue française de psychanalyse*, 12 (1), 101–124.
- . (1984). “Entrevista a los fundadores, III: Celes E. Cárcamo,” *Revista de psicoanálisis de la Asociación psicoanalítica argentina*, 41 (6), 987–1000.
- . (1992). *Escritos*. Buenos Aires: Kargieman.
- Célérier, Marie-Claire. (1977). La boulimie compulsive. *Topique*, 18, 95–116.
- Cénac, Michel. (Jan.–Feb.–March 1943). Psychiatrie et psychanalyse. L’apport de la psychanalyse à la psychiatrie,” *Annales médico-psychologiques*, 101 (1), 278–288.
- Caïn, Jacques, R. Sarles, and F. Berretti. (1984). Aspects psychosomatiques de la recto-colite hémorragique. *Encéphale*, 44.
- Cahn, Raymond. (1991). Du sujet. *Revue française de psychanalyse*, 55, 5–6, 1371–1490.
- . (1996). *La cure psychanalytique*. Paris: Presses Universitaires de France.
- . (1997). Le processus de subjectivation à l’adolescence. In M. Perret Catipovic, and F. Ladame (Eds.), *Adolescence et psychanalyse: une histoire* (pp. 213–227). Lausanne, France: Delachaux et Niestlé.
- . (1998). *L’Adolescent dans la psychanalyse: l’aventure de la subjectivation*. Paris: Presses Universitaires de France.
- Caillot, Jean-Pierre, and Decherf, Gérard. (1982). *Paradoxalité et thérapie familiale psychanalytique*. Paris: Clancier-Guénard.
- Canguilhem, Georges. (1989). *The normal and the pathological* (Carolyn R. Fawcett & Robert S. Cohen, Trans.). New York: Zone Books. (Original work published 1966)
- . (1989). *The Normal and the Pathological* (Carolyn R. Fawcett, Trans.). New York: Zone Books.
- Caper, Robert. (2001). The place of affect in the representational world. *International Journal of Psychoanalysis*, 82, 597–600.
- Caries, Egea. (1983). Introducción al psicoanálisis en España, 1893–1922. Doctoral thesis, University of Murcia.
- Carnap, Rudolf. (1942). *Introduction to Semantics*. Cambridge, MA: Harvard University Press.
- . (1978). Affective response of the analyst to the patient’s communications. *International Journal of Psychoanalysis*, 59 (2–3), 335–340.
- Carotenuto, Aldo, and Trombetta, Carlo. (1982). *A secret symmetry: Sabina Spielrein between Jung and Freud* (Arno Pomerans, John Shepley, and Krishna Winston, Trans.). New York: Pantheon Books. (Original work published 1977)
- Carraz, Yves, and Ehrhardt, Raymond. (1973). L’automutilation chez des enfants en institution. *Revue de neuropsychiatrie infantile*, 21, 217–227.
- Carrouges, Michel. (1950). *André Breton et les données fondamentales du surréalisme*. Paris: Gallimard.
- Carroy, Jacqueline. (1988). L’école hypnologique de Nancy. I: Liébeault, Beaunis, Liégeois et Delbœuf. II: Bernheim, Charcot et Freud, le Pays lorrain. *Journal de la Société d’archéologie lorraine et du Musée historique lorrain*. 2–3, 108–116; 159–166.
- . (1991). *Hypnose, suggestion et psychologie: l’invention de sujets*. Paris: Presses Universitaires de France.
- Caruso, Igor A. (1962). *Psychanalyse pour la personne*. Paris: Le Seuil.
- . (1964). *Existential psychology: from analysis to synthesis* (Eva Krapf, Trans.). New York: Herder and Herder. (Original work published 1952)
- Carvajal, Guillermo. (1993). *Adolecer: La aventura de una metamorfosis. una visión psicoanalítica de la adolescencia* Bogotá: Printing Service Network.
- Casaula Eleonora, Coloma Jaime, and Jordán, Juan Francisco (Eds.). (1991). *Cuarenta años de psicoanálisis en Chile*, Santiago: Ananké.
- Casement, Patrick. (1990). *Further learning from the patient. The analytic space and process*. London/New York: Tavistock/Routledge.
- Casoni, D. (2002). ‘Never twice without thrice’: outline for traumatic neurosis. *International Journal of Psychoanalysis*, 83, 137–160.
- Castarède, Marie-France. (1991). *La Voix et les Sortilèges*. 3rd ed. Paris: Les Belles Lettres.
- Castel, Pierre-Henri. (1998). *Introduction à “L’interprétation du rêve” de Freud*. Paris: Presses Universitaires de France.
- . (1998). *Introduction à “L’interprétation du Rêve” de Freud*. Paris: Presses Universitaires de France.
- Cazas, Odile; Dhôte, Alain; Bouttier, Daniel; Ginestet, Daniel. (1990). L’hospitalisation conjointe de la mère

- et de son nourrisson dans un service de psychiatrie adulte. *Psychiatrie de l'enfant*, 33, 1, 635–674.
- Certeau, Michel de. (1970). *The Possession at Loudun* (Michael B. Smith, Trans.). Chicago: University of Chicago Press, 2000.
- . (1973). *L'absent de l'histoire*. Repères, Paris: Mame.
- . (1975). *The writing of history* (Tom Conley, Trans.). New York: Columbia University Press, 1988.
- . (1982). *The mystic fable* (Michael B. Smith, Trans.). Chicago: University of Chicago Press, 1992.
- . (1987). *Histoire et psychanalyse entre science et fiction*. Paris: Gallimard, Folio.
- Cesio, Fidias. (1985). Heinrich Racker. *Revista de psicoanálisis de la Asociación psicoanalítica argentina*, 42, 2.
- Chabanier, Jacques. (1988). *Le centre médico-psychopédagogique: son histoire, sa pratique, ses valeurs*. Paris: Paidós–Le Centurion.
- Chang, S.C. and Kim, K.I. (1973). Psychiatry in South Korea. *American Journal of Psychiatry* 130, 6. 667–669.
- Changeux, Jean-Pierre. (1983). *L'Homme neuronal*. Paris: Fayard.
- Charcot, Jean Martin. (1890). *Oeuvres complètes. Leçons sur les maladies du système nerveux*. Paris: Progrès Médicale.
- Charron, Gyslain. (1993). *Le discours et le Je*. Klincksieck, Canada: Presses de l'université de Laval.
- Chasseguet-Smirgel, Janine. (1970). Feminine guilt and the Oedipus complex. In her *Female sexuality* (pp. 94–134). Ann Arbor: University of Michigan Press. (Original work published 1964)
- . (1973). Essai sur l'Idéal du Moi. Contribution à l'état psychanalytique de "la maladie d'idéalité." *Revue française de psychanalyse*, 37 (5–6), 735–929.
- . (1978). Hommage à Marc Schlumberger. *Revue française de psychanalyse*, 42, 4, 757–759.
- . (1985). *The ego ideal: a psychoanalytic essay on the malady of the ideal* (Paul Barrows, Trans.). London: Free Association Books. (Original work published 1975)
- . (1987). *L'acting out: quelques réflexions sur la carence d'élaboration psychique*. *Revue française de psychanalyse*, 51, 4.
- Chasseguet-Smirgel, Janine, Luquet-Parat, Catherine J., Grunberger, Béla, et al. (1970). *Female sexuality: new psychoanalytic views*. Ann Arbor: University of Michigan Press. (Original work published 1964)
- Chebel, Malek. (1993). *L'imaginaire arabo-musulman*. Paris: Presses Universitaires de France.
- Chemouni, Jacquy. (1984). *Georg Groddeck, psychanalyste de l'imaginaire: psychanalyse freudienne et psychanalyse groddeckienne*. Paris: Payot.
- . (1990). *Histoire du mouvement psychanalytique*. Paris: Presses Universitaires de France.
- . (1991). *Freud, la psychanalyse et le judaïsme*. Paris: Éditions universitaires.
- Chentrier, Théodore. (1981). *Vivre avec soi-même et avec les autres* (M. Hoffman, Ed.). Montreal: La Mortagne.
- . (1984). *Un art de vivre* (M. Hoffman Ed.). Montreal: La Mortagne.
- Chentrier, Théodore, and Jury, Paul (April–May 1948). La culpabilité: quelques précisions et quelques questions. *Psyché*, 18–19.
- Cherki, Alice. (2000). *Frantz Fanon, portrait*. Paris: Seuil.
- Chertoff, Judith M. (1989). Negative oedipal transference male pt. female analyst: terminat. *Journal of the American Psychoanalytic Association*, 37, 687–714.
- Chertok, Léon. (1966). *Hypnosis* (D. Graham, Trans.). Oxford, New York: Pergamon Press. (Original work published 1963)
- . (1981). *Sense and nonsense in psychotherapy: The challenge of hypnosis* (R.H. Ahrenfeldt, Trans.). Oxford, New York: Pergamon Press. (Original work published 1979)
- Chertok, Léon, and Saussure, Raymond de. (1973). *Naissance du psychanalyste*. Paris: Payot.
- . (1979). *The therapeutic revolution, from Mesmer to Freud*. (R. H. Ahrenfeldt, Trans.). New York: Brunner/Mazel.
- Chertok, Léon, and Stengers, Isabelle. (1992). *A critique of psychoanalytic reason: hypnosis as a scientific problem from Lavoisier to Lacan* (Martha Noel Evans in collaboration with the authors, Trans.). Palo Alto, CA: Stanford University Press. (Original work published 1989)
- Cheshire, Neil M. (1996). The empire of the ear: Freud's problem with music. *International Journal of Psychoanalysis*. 77,1127–1168.
- Chiland, Colette. (1997). *Changer de sexe?* Paris : Odile Jacob.
- . (1999). *Le sexe mène le monde*. Paris: Calmann-Lévy.
- Chiland, Colette, and Roubertoux, Pierre. (1975–1976). Freud et l'hérédité. *Bulletin de psychologie*, 4–7.
- Chodorow, Nancy. (1978). *The reproduction of mothering. Psychoanalysis and the sociology of gender*. Berkeley: University of California Press.

- . (1989). *Feminism and psychoanalytic theory*. New Haven: Yale University Press.
- . (1992). Heterosexuality as compromise formation: A theory of sexual development. *Psychoanalysis and Contemporary Thought*, 15, 267–304.
- Chodorow, Nancy. (1994). *Femininities, masculinities, sexualities. Freud and beyond*. Lexington, KY: University Press of Kentucky.
- Choisy, Maryse. (1961). *Psychoanalysis of the prostitute*. New York: Philosophical Library. (Original work published 1928)
- . (1977). *Mémoires : sur le chemin de Dieu on rencontre d'abord le Diable*. Paris: Émile Paul.
- Chrzanowski, G. (1979). Editorial: cultural and transcultural dimensions of. *Journal of the American Academy of Psychoanalysis*, 7, 331–334.
- Cifali, Mireille. (1982). “Entre Genève et Paris: Vienne,” *Bloc-notes de la psychanalyse*, 2, 91–127.
- . (1990). De quelques remous helvétiques autour de l’analyse profane. *Revue internationale d’histoire de la psychanalyse*, 4, 291–305.
- . (1991). Notes autour de la première traduction française d’une œuvre de Sigmund Freud. *Revue internationale d’histoire de la psychanalyse*, 4, 291–305.
- Cifali, Mireille, and Moll, Jeanne. (1985). *Pédagogie et psychanalyse*. Paris: Dunod.
- Clérambault, Gatian de, and Brousseau, Albert. (1987). Coexistence de deux délires: persécution et érotomanie (présentation de malades). In *Œuvres psychiatriques* (p. 323). Paris: Frénésie. (Reprinted from *Bulletin de la Société clinique de médecine mentale* (Dec. 1920).
- Claparède, Edouard. (1920). Freud et la psychanalyse. *Revue de Genève*, 6, 850–851.
- Claude, Henri. (1913). Zur Psychopathologie des Alltagslebens, par Sigm. Freud, de Vienne (De la psychopathologie de la vie de tous les jours). (4th ed.). Berlin: Lib. S. Karger.
- . (May 1924). Freud et la méthode psychanalytique. *Les nouvelles littéraires*.
- Clavreul, Jean. (1959). La parole de l’alcoolique. *Psychanalyse*, 5, 257–280.
- Cloutier, Yvan. (1988). La naissance de la psychanalyse à Montréal. *Philosophiques*, 15(1), 221–225. (Reprinted from *Frayages*, 3 (1987).)
- Clower, Virginia L. (1976). Theoretical implications of masturbation in latency girls.. *Journal of the American Psychoanalytic Association*, 24, 109–126.
- Clowes, Erika. (1996). Oedipal themes in latency: analysis of the “farmer’s daughter”joke. *Psychoanalytic Study of the Child*, 51, 436–454.
- Coblence, F. (1996). *Serge Lebovici*. Paris: Presses Universitaires de France.
- Cocks, Geoffrey. (1997). *Psychotherapy in the Third Reich: The Göring Institute* (2nd rev. ed.). New Brunswick, NJ: Transaction Publishers.
- Codet, Henri. (1936). La méthode psychanalytique et la doctrine freudienne, compte rendu. *L’Évolution psychiatrique*, 3, 92–96.
- Codet, Odette. (1939). À propos de trois cas d’anorexie mentale. *Revue française de psychanalyse*, 11 (2), 253–272. (Republished : (1948). *Revue française de psychanalyse*, 12 (1), 81–100.)
- Coen, Stanley. (2000). Affect, somatisation and symbolisation. *International Journal of Psychoanalysis*, 81, 159–161.
- Cohen, D.W. (2002). Transference and countertransference in analysis of narcissism. *Psychoanalytic Review*, 89, 631–652.
- Cohen, J. (1997). Child and adolescent psychoanalysis: research, practice, and theory. *International Journal of Psychoanalysis*, 78, 499–520.
- Cohen, Yecheskiel. (1988). The “golden fantasy”350.
- Collège International de Philosophie. (1991). *Lacan avec les philosophes*. Paris: Editions Albin Michel.
- Collectif. (1930). *Zehn Jahre Berliner psychoanalytisches Institut (1930)*. Wien, Internationaler psychoanalytischer Verlag.
- Colonomos, Fanny. (Ed). (1985). *On forme des psychanalystes: rapport original sur les dix ans de l’Institut psychanalytique de Berlin, 1920–1930*. Paris: Denoël.
- Compton, Allan. (1992). The psychoanalytic view of phobias Part I.: Freud’s theories of phobias and anxiety. *Psychoanalytic Quarterly*, 61, 206–229.
- . (1992). The psychoanalytic view of phobias Part II.: Infantile phobias. *Psychoanalytic Quarterly*, 61, 230–256.
- . (1992). The psychoanalytic view of phobias Part III. Agoraphobia and other phobias of adults. *Psychoanalytic Quarterly*, 61, 400–425.
- . (1992). The psychoanalytic view of phobias Part IV. General theory of phobias and anxiety. *Psychoanalytic Quarterly*, 61, 426–448.
- Console, William, et. al. (1977). *The first encounter: The beginnings in psychotherapy*. New York: Jason Aronson.

- Conté, Claude, and Perrier, François. (1968). Névrose phobique. In *Encyclopédie médico-chirurgicale*, Vol. *Psychiatrie*. (p. 37–360). Paris: E.M.-C.
- . (1994). *Il Pensiero di natura*. Milano: Sipiel.
- Contri, B. Giacomo. (1978). *Lacan in Italia*. Milan: La Salamandra.
- Cooper, David. (1967). *Psychiatry and anti-psychiatry*. London: Tavistock
- Cooper, Martha, & Makay, John J. (1988). Knowledge, power, and Freud's Clark Conference lectures. *Quarterly Journal of Speech*, 74, 416–433.
- Corrao, F. (1992). Modelli psicoanalitici. Mito passione memoria. Laterza: Roma-Bari.
- Cosnier, Jacques. (1984). La psychanalyse, le langage et la communication. *Psychothérapies*. 4 (4), 215–222
- Cournut, Jean. (1991). *L'Ordinaire de la passion*. Paris: Presses Universitaires de France.
- . (1997). *Épître aux oédiptiens*. Paris: Presses Universitaires de France.
- . (2000). Le transfert négatif. Acceptions diverses plus ou moins pessimistes. *Revue française de psychanalyse*, 64, 2, 361–365.
- Couvreur, Catherine. (2000). Un mouvement qui est toujours le même, négatif. *Revue française de psychanalyse*, 64, 2, 367–381.
- Couvreur, Catherine, Oppenheimer, Agnès, Perron, Roger, and Schaeffer, Jacqueline (Eds.). (1996). *Psychanalyse, neurosciences, cognitivisme*. Paris: Presses Universitaires de France.
- Cox, John, and Holden, Jeni (eds.). (1994). *Perinatal psychiatry: Use and misuse of the Edinburgh Postnatal Depression Scale*. London: Gaskell.
- Cox, John L., Holden, Jeni M., and Sagovsky, R. (1987). Detection of Postnatal Depression. *British Journal of Psychotherapy*, 150, 782–786.
- Cramer, Bertrand, et al. (1983). Trente-six encopréti-ques en thérapie. *Psychiatrie de l'enfant*, 26, 2, 309–410.
- Cremerius, Johannes. (1969–1971). *Karl Abraham: psychoanalytische Studien*. Frankfurt am Main: S. Fischer.
- . (1980). Freud bei der Arbeit über die Schulter geschaut. *Beiheft zum Jahrbuch der Psychoanalyse*. 123–158.
- Cucurullo, Antonio, et al. (1982). La psychanalyse en Argentine. In Roland Jaccard (ed.), *Histoire de la psychanalyse*, vol. II: 395–444. Paris: Hachette.
- Cushing, M. (1953). Psychoanalytic treatment of man with ulcerative colitis. *Journal of the American Psychoanalytic Association*, 1, 510–518.
- Cuvellier, André. (1987). *Hypnose et suggestion. De Lié-beault à Coué*. Nancy, France: Presses Universitaires de Nancy.
- Cyssau, Catherine. (1997). La peur et les phobies: des névroses d'angoisse à l'hystérie d'angoisse. In *Peurs et phobies* (A. Fine, A. Le Guen, and A. Oppenheimer, Eds.). Paris: Presses Universitaires de France.
- Détienne, Marcel. (1979). Les mythologues de la cité. *Revue française de psychanalyse*, 43 (3), 355–374.
- Dadoun, Roger. (1972). Les ombilics du rêve. *Nouvelle revue de psychanalyse*, 5, 239–254.
- . (1975). *Cent fleurs pour Wilhelm Reich*. Paris: Payot.
- . (1986). La psychologie de masse du fascisme. In Olivier Duhamel, François Châtelet, and Évelyne Pisier (Eds.), *Dictionnaire des œuvres politiques*. Paris: Presses Universitaires de France.
- . (1987). Psychanalyse et politique. In P. Ory (Ed.), *Nouvelle histoire des idées politiques*. Paris: Hachette.
- . (1995). *La psychanalyse politique*. Paris: Presses Universitaires de France.
- Dalí, Salvador. (1933). Le mythe tragique de l'Angé-lus de Millet. *Minotaure*, 1.
- Dalbiez, Roland. (1972). *Psychoanalytical method and the doctrine of Freud*. (T. F. Lindsay, Trans.). Freeport, N.Y.: Books for Libraries Press. (Original work published 1936)
- Daniel, Lagache. (1947). *La Jalousie amoureuse. Psychologie descriptive et psychanalyse*. Paris, Presses Universitaires de France.
- Darmon, Marc. (1990). *Essais sur la topologie Lacanienne*. Paris: Éditions de l'Association Freudienne internationale.
- Darnton, Robert. (1968). *Mesmerism and the end of the Enlightenment in France*. Cambridge, MA: Harvard University Press.
- Daudet, Alphonse. (1872). *Aventures prodigieuses de Tartarin de Tarascon*. n.p.
- Davanzo, Hernán. (1993). Origenes del psicoanálisis en Chile. *Revista chilena de psicoanálisis*, 10, 58–65.
- David, Christian. (1971). *L'État amoureux*. Paris: Payot.
- . (1975). La bisexualité psychique, élément d'une réévaluation. *Revue française de psychanalyse*, 39 (5–6), 713–856.
- . (1980). Metapsychological reflections on the state of being in love. In Lebovici, Serge, and Widlocher, Daniel. *Psychoanalysis in France*. (p. 87–100). New York: International Universities Press.

- . (1983). Souffrance, plaisir et pensée, un mixte indissociable. In *Souffrance, plaisir et pensée*. Paris: Les Belles Lettres.
- . (1985). À propos de la représentance de l'affect. *Revue Française de Psychanalyse*, 69, 3, 797–806.
- . (1996). Post-scriptum à l'état amoureux. *Revue française de psychanalyse*, 60, 3, 633–642.
- David, Didier. (1996). Le désir d'enfant." In D. David and S. Gosme-Sèguret (Eds.). *Le Diagnostic prénatal*. Paris: E.S.F.
- David, Michael. (1966). *La psicoanalisi nella cultura italiana*. Turin: Boringhieri.
- Davidson, L. (1980). Ethnic roots, transcultural methodology and psychoanalysis. *Journal of the American Academy of Psychoanalysis*, 8, 273–278.
- Davies, J. Keith, and Botting, Wendy. (1989). La bibliothèque de Freud. In Eric Gubel (Ed.), *Le sphinx de Vienne, Sigmund Freud: l'art et l'archéologie*, pp. 199–201. Gent, Belgium: Ludion.
- Davison, Susan, rep. (1998). Panel: A contemporary review of the psychosexual phases of development. *International Journal of Psychoanalysis*, 79, 164–167.
- Davison, W., Bristol, C., and Pray, M. (1986). Turning aggression on the self: study of psychoanalytic process. *Psychoanalytic Quarterly*, 55, 273–295.
- Dayan, Maurice. (1985). *Inconscient et réalité*. Paris: Presses Universitaires de France.
- De Marchi, Luigi. (1973). *Wilhelm Reich, biographie d'une idée*. Paris: Fayard.
- . (1981). *Psycho-politique*. Paris: Payot.
- De Neuter, Patrick. (1992). Le père réel et la sexualité du fils. *Psychiatrie de l'enfant*, 13, 65–80.
- . (1993). Fonctions paternelles et naissances du sujet. *Cahiers des sciences familiales et sexologiques*, 16, 105–127.
- Debesse, Maurice. (1941). *La crise d'originalité juvénile*. Paris: Presses Universitaires de France.
- Decker, Hannah. (1991). *Freud, Dora, and Vienna 1900*. New York: The Free Press.
- Dehmlow, Raimund. and Heuer, Gottfried. (1999). *Otto Gross: Werkverzeichnis und Sekundärschrifttum*. Hannover: Laurentius.
- Dejours, Christophe. (1986). *Le Corps entre biologie et psychanalyse*. Paris: Payot.
- Delaisi de Parseval, Geneviève. (1981). *La part du père*. Paris: Seuil.
- Delarai-Chabaux, Catherine, and Roche, Jean-François. (1996). Les coupures cutanées à l'adolescence: le carving. Sens et fonction du symptôme. *Neuropsychiatrie de l'enfance et de l'adolescence*, 44, 43–48.
- Delay, Jean. (1946). *Les dérèglements de l'humeur*. Paris: Presses Universitaires de France.
- . (1947). *Les reposantes*. Paris: Gallimard.
- . (1953). *Études de psychologie médicale*. Paris: Presses Universitaires de France.
- . (1956). *Aspects de la psychiatrie moderne*. Paris: Presses Universitaires de France.
- . (1960). *Discours de réception à l'Académie française*. Paris: Gallimard.
- . (1963). *The Youth of André Gide* (June Guicharnaud, Trans.). Chicago: University of Chicago Press. (Abridged.)
- . (1971–1986). *Avant-mémoire*. Paris: Gallimard.
- Delboeuf, Joseph. (1889). *Le Magnétisme animal. À propos d'une visite à l'École de Nancy*. Paris: Félix Alcan.
- . (1993). *Le sommeil et les Rêves et autres textes*. Paris: Fayard. (Original work published in 1885)
- Delegay-Siksou, Joyceline. (1986). Allaiter: au sein ou au biberon? Nourrir un enfant. *Lieux enfance*, 6–7, 35–57.
- Deleuze, Gilles. (1973). À quoi reconnaît-on le structuralisme? In François Châtelet (Ed.), *Histoire de la philosophie, idées, doctrines, le XXe siècle*. (pp. 299–335). Paris: Hachette.
- . (1992). *Expression in philosophy: Spinoza*. Cambridge, MA: Zone Books.
- Deleuze, Gilles, and Guattari, Félix. (1977). *Anti-Oedipus: Capitalism and Schizophrenia*. (Robert Hurley, Mark Seem, and Helen R. Lane, Trans.). New York: Viking. (Original work published 1972)
- Deleuze, Gilles, and Parnet, Claire. (1977). *Dialogues*. Translated by Hugh Tomlinson and Barbara Habberjam. London: Athlone Press, 1987.
- Delgado, Honorio. (1989). *Freud y el psicoanálisis*. (J. Mariátegui, Comp.). Lima: University Cayetano Heredia.
- Delion, Pierre (Ed.). (1994). *Actualité de la psychothérapie institutionnelle*. Vigneux, France: Éditions Matrice.
- Delrieu, Alain. (1997). *Sigmund Freud. Index thématique*. Paris: Anthropos.
- Demangeat, Michel. (1999). *Historisation et structure dans les névroses passionnelles*. Bordeaux: Cahiers de Trait.
- Denis, Paul. (1981). J'aime pas être un autre. L'inquiétante étrangeté chez l'enfant. *Revue française de psychanalyse*, 65, 3.

- . (1988). L'avenir d'une désillusion: Le contretransfert, destin du transfert. *Revue française de psychanalyse*, 52 (4), 829–842.
- . (1992). Emprise et théorie des pulsions. *Revue française de psychanalyse*, 56 (5), 1295–1421.
- . (1997). *Emprise et satisfaction, les deux formants de la pulsion*. Paris: Presses Universitaires de France.
- Derrida, Jacques. (1974). *Of grammatology* (Gayatri Chakravorty Spivak, Trans.). Baltimore: Johns Hopkins. (Original work published 1967)
- . (1987). *The post card: From Socrates to Freud and beyond* (Alan Bass, Trans.). Chicago: University of Chicago Press.
- . (1998). *Resistances of psychoanalysis* (Peggy Kamuf, Pascale-Anne Brault, and Michael Naas, Trans.). Stanford, CA: Stanford University Press.
- Descombey, Jean-Paul. (1985). *Alcoolique, mon frère, toi: l'alcoolisme entre médecine, psychiatrie et psychanalyse*. Toulouse: Privat.
- . (1992). Alcoolisme: dépression ou addiction? *Information Psychiatrique*, 68, (4), 338–345.
- . (1994). *Précis d'alcoologie clinique*. Paris: Dunod.
- Desmond, Helen, and Schneider, Arnold Z. (1994). The psychoanalytic lawsuit: expanding opportunities for psychoanalytic training and practice. In Robert C. Lane and Murray Meisels (Eds.), *A History of the division of psychoanalysis of the American Psychological Association* (pp. 313–335). Hillsdale, NJ: Lawrence Erlbaum Associates Publishers.
- Desoille, Robert. (1938). *Exploration de l'affectivité subconsciente par la méthode du rêve-éveillé: sublimation et acquisitions psychologiques*. Paris: J. L. d'Artrey.
- . (1945). *Le rêve-éveillé en psychothérapie: essai sur la fonction de régulation de l'inconscient collectif*. Paris: Presses Universitaires de France.
- . (1961). *Théorie et pratique du rêve-éveillé-dirigé*. Geneva: Mont-Blanc.
- . (1971). *Marie-Clotilde. Une psychothérapie par le rêve-éveillé-dirigé: un cas de névrose obsessionnelle*. Paris: Payot.
- . (1973). *Entretiens sur le rêve-éveillé-dirigé en psychothérapie*. Paris: Payot.
- Dessuant, Pierre. (1999). *Béla Grunberger*. Paris: Presses Universitaires de France.
- Deutsch, Felix. (1947). In memoriam—Hanns Sachs 1881–1947. *American Imago*, 4 (2), 3–14.
- Deutsch, Helene. (1930). The significance of masochism in the mental life of women. *International Journal of Psychoanalysis*, 11, 48–60.
- . (1934). Über einen Typus der Pseudoaffektivität ("Als ob"). *Internationale Zeitschrift für Psychoanalyse*, 20.
- . (1942). Some forms of emotional disturbance and their relationship to schizophrenia. *Psychoanalytic Quarterly*, 11, 301–321
- . (1944–1945). *The psychology of women. A psychoanalytic interpretation* (Vols. 1–2). New York: Greene and Stratton.
- . (1955). The impostor: Contribution to ego psychology of a type of psychopath. *Psychoanalytic Quarterly*, 24, p. 483–505.
- . (1965). Hysterical fate neurosis. In her *Neuroses and character types* (pp. 14–28). New York: International Universities Press. (Original work published 1930.)
- . (1967). *Neuroses and character types*. New York: International Universities Press.
- . (1973). *Confrontations with myself*. New York: W.W. Norton.
- . (1991). *Psychoanalysis of the sexual functions of women* (P. Roazen, Ed., and Eric Mosbacher, Trans.). London: Karnac. (Original work published 1925)
- . (1992). *The therapeutic process, the self, and female psychology*. (Paul Roazen Ed.). New Brunswick, NJ: Transaction.
- Deutschen Psychoanalytischen Gesellschaft (Ed.). (1930). *Zehn Jahre Berliner psychoanalytisches Institut*. Vienna: Internationaler Psychoanalytischer Verlag.
- Devereux, Georges. (1952). Psychiatry and anthropology: some research objectives. *Bulletin of the Menninger Clinic*, 16, 167–177.
- . (1953). Cultural factors in psychoanalytic therapy. *Journal of the American Psychoanalytic Association*, 1, 4, 629–655.
- . (1970). *Essais d'ethnopsychiatrie générale*. Paris, Gallimard.
- . (1972). *Ethnopsychanalyse complémentariste*. Paris: Flammarion, 1985.
- . (1978). L'Ethnopsychiatrie. *Ethnopsychiatria*, 1 (1), 7–13.
- . (1980). *Basic problems of ethnopsychiatry* (Basia Miller Gulati, and George Devereux, Trans.). Chicago: University of Chicago Press. (Original work published 1970.)

- . (1985). *Ethnopsychanalyse complémentariste*. Paris, Flammarion. (Original work published 1972)
- Devereux, Georges, and Simon, Bennett. (1976). *Dreams in Greek tragedy. An ethno-psychoanalytical study*. Berkeley, Los Angeles: University of California Press.
- Diatkine, Gilbert, and Gibeault, Alain. (1996). Le statut du psychothérapeute et/ou du psychanalyste. *Bulletin de la Fédération européenne de psychanalyse*, 46, 119–141.
- Diatkine, Gilbert, Gibeault, Alain, Gibeault, Monique, and Vincent, Michel. (1993). La psychanalyse en Europe orientale. In Gilbert Diatkine, Gérard Le Goues, and Ilana Reiss-Schimmel (Eds.), *La psychanalyse et l'Europe de 1993*. Paris: Presses Universitaires de France.
- Diatkine, René. (1964). Agressivité et fantasmes d'agression. Paris: Presses Universitaires de France.
- . (1966). Intervention au 7e séminaire de perfectionnement. *Revue française de psychanalyse*, 30 (3), pp. 324–344.
- . (1969). L'enfant prépsychotique. *Psychiatrie de l'enfant*, 22, 2, 413–446.
- . (1974). Rêve, illusion et connaissance. *Revue française de psychanalyse*, 38 (5–6), 769–820.
- . (1989). Introduction à une discussion sur le concept d'objet en psychanalyse. *Revue française de psychanalyse*, 53 (4), 1037–1043.
- . (1990). Remémoration, prise de conscience. *Revue française de psychanalyse*, 54 (4), 911–921.
- . (1994). *L'enfant dans l'adulte ou l'éternelle capacité de reverie*. Neuchâtel-Paris: Delachaux & Niestlé.
- , and Éric Valentin. Les phobies de l'enfant et quelques autres formes d'anxiété infantile. In *Nouveau Traité de psychiatrie de l'enfant et de l'adolescent*. Paris: Presses Universitaires de France, 1985.
- , and Simon, Janine. (1972). *La psychanalyse précoce*. Paris: Presses Universitaires de France.
- Didi-Huberman, Georges. (2003). *The invention of hysteria: Charcot and the photographic iconography of the Salpêtrière* (Alisa Hartz, Trans.). Cambridge: MIT Press.
- Director, L. (2002). Relational psychoanalysis in the treatment of chronic drug & alcohol abuse. *Psychoanalytic Dialogues*, 12, 551–580.
- Dolto, Françoise. (1971). Dominique: the analysis of an adolescent. New York: Outerbridge and Lazard.
- . (1971). *Psychanalyse et pédiatrie*. Paris: Seuil. (Original work published 1939)
- . (1981). *Au jeu du désir: essais clinique*. Paris: Seuil.
- . (1982). *Séminaire de psychanalyse d'enfants*. Paris: Seuil.
- . (1984). *L'image inconsciente du corps*. Paris: Seuil.
- . (1985). *La cause des enfants*. Paris: R. Laffont.
- . (1985). L'Institution soignante. Cahiers de l'IPC 1985, n° 1, pp. 33-71. Institut des Psychologues Cliniciens. Colloque du 23 novembre 1984.
- . (1986). *Enfances*. Paris: Seuil.
- . (1987). *Dialogues québécois*. Paris: Editions du Seuil.
- . (1987). *Solitude*. Paris: Vertiges du Nord.
- . (1989). *Autoportrait d'une psychanalyste*. Paris: Seuil.
- . (1990). *Lorsque l'enfant paraît*. Paris: Seuil. (Original work published 1977–1979)
- . (1992). *Inconscient et destins*. Paris: Seuil.
- . (1994). *Les Étapes majeures de l'enfance*. Paris: Gallimard.
- . (1996). *Les évangiles et la foi au risque de la psychanalyse*. Paris: Gallimard.
- . (1996). La libido génitale et son destin féminin. In *her Sexualité féminine. La libido génitale et son destin féminin*. Paris: Gallimard. (Original work published 1964)
- . (1997). *Sentiment de soi, aux sources de l'image du corps*. Paris: Gallimard.
- Dolto, Françoise, and Angelino, Inès. (1988). *Quand les parents se séparent*. Paris: Seuil.
- Dolto, Françoise, and Nasio, Juan-David. (1987). *L'enfant du miroir*. Paris: Rivages.
- Dolto, Françoise, and Séverin, Gérard. (1979). *The Jesus of psychoanalysis: a Freudian interpretation of the Gospel*. (Helen R. Lane, Trans.). Garden City, NY: Doubleday. (Original work published 1977)
- Dolto, Françoise, Baldy Moulinier, Claude, Guillerault, Gérard, and Kouki, Elisabeth. (2002). *Tout est langage*. Paris: Gallimard. (Original work published 1987)
- Donnet, Jean-Luc. (1973). Le divan bien tempéré. *Nouvelle revue de psychanalyse*, 8, 23–49.
- . (1995). *Surmoi I: le concept Freudien et la règle fondamentale*. Paris: Presses Universitaires de France.
- . (1997). L'humoriste et sa croyance. *Revue française de psychanalyse*, 61, 3.
- Donnet, Jean-Luc, and Green, André. (1973). *L'enfant de ça*. Paris: Minuit.
- Doolittle, Hilda. (1974). *Tribute to Freud*. Boston: David R. Godine.



- Dor, Joël. (1989). *Le Père et sa Fonction en psychanalyse*. Paris: Point hors ligne.
- . (1994). *Nouvelle bibliographie des travaux de Jacques Lacan*. Paris: Éditions et Publications de l'École Lacanienne.
- . (1997). *Introduction to the reading of Lacan: the unconscious structured like a language*. (Judith Feher Gurewich, Ed., in collaboration with Susan Fairfield). Northvale, NJ: J. Aronson. (Original work published 1985–1992)
- Dorer, Maria. (1932). Historische Grundlagen der Psychoanalyse. Leipzig: Meiner.
- Dorey, Roger. (1981). La relation d'emprise. *Nouvelle Revue de psychanalyse*, 24: 117–140; reprinted in *Le Désir de savoir*, Paris: Denoël, 1988.
- . (1986). L'amour au travers de la haine. *Nouvelle Revue de psychanalyse*, 33, 75–94.
- . (1988). *Le Désir de savoir*. Paris: Denoël.
- Dorgeuille, Claude. (1981). *La Seconde Mort de Jacques Lacan*. Paris: Actualité freudienne.
- Doria-Medina, Roberto. (1993). Letter from Buenos Aires: Celes Cárcamo's writings. *Psychoanalytical Books*, 4, 585–594.
- Dorsey, Denise. (1996). Castration anxiety or feminine genital anxiety? *Journal of the American Psychoanalytic Association*, 44(S), 283–302.
- Dosuzkov, Theodor. (1965). Über die drei Haupttypen des neurotischen Stotterns. *Acta XIII Congressus therapia vocis et loquelam*, Vienna.
- . (1965). Skoptophobie: die vierte Übertragungsneurose. *Psyche*, 19, 537–546.
- . (1969). Zur Frage der Dysmorphophobie. *Psyche*, 23, 683–699.
- . (1975). Idrosophobia: A Form of Pregenital Conversion. *Psychoanalytic Quarterly*, 64, 253–265.
- . (1979). Skoptophobie bei männlichen und weiblichen Patienten. *Psyche*, 33, 620–633.
- Drell, Martin J. (1982). Hermine Hug-Hellmuth, A pioneer in child analysis. *Bulletin of the Meninger Clinic*, 46 (2), 138–150.
- Drouilly, Jean. (1977). Freud et Dostoiewski. *Évolution psychiatrique*, 42, 1, 127–140.
- Druon, Catherine. (1996). *À l'écoute du bébé prématuré: une vie aux portes de la vie*. Paris: Aubier.
- Dubal, George. (1947). *Psychanalyse et connaissance: L'évolution des psychothérapies et la psychanalyse; Le problème de l'instinct; Le problème de la connaissance*. Geneva, Switzerland: Éditions du Mont-Blanc.
- . (1960). *Moi et les autres: applications de la psychanalyse à la pédagogie et à la pensée dialectique*. Neuchâtel, Switzerland: Éditions Delachaux et Niestlé.
- Duchatelet, B. (1976). Á propos d'une correspondance qui n'est pas encore générale. *Revue d'histoire littéraire de la France*, 76, 958–975.
- Dufour, Roger. (1978). *Écouter le rêve. Le Rêve-éveillé-dirigé analytique. Écoute et repères de l'Inconscient. Poésie et mythe de la psychanalyse*. Paris: Robert Laffont.
- Dugas, Ludovic. (1898). Observations et documents: Un cas de dépersonnalisation. *Revue philosophique*, 14, 500–507.
- Dugautiez, Maurice. (1953). J. Leuba n'est plus. *Bulletin de l'Association des psychanalystes de Belgique*, 15.
- . (1953). Réflexions sur l'article "Les tendances de la psychanalyse à New York" du Pr. Reding. *Bulletin de l'Association des psychanalystes de Belgique*, 16.
- Duhamel, Pascale. (1988). Eugénie Sokolnicka (1884–1934): entre l'oublié et le tragique. Mémoire pour le Certificat d'études spéciales de psychiatrie. Bordeaux-II.
- Dumézil, Georges. (1968–1973). *Mythe et épopée* (vols. 1–2). Paris: Gallimard.
- Dumas, Didier. (1985). *L'Ange et le fantôme: introduction à la clinique de l'impensé généalogique*. Paris: Minuit.
- Dumesnil, F. (1984). Analyse différentielle de cinq pathologies précoces et des automutilations qui en découlent. *Neuropsychiatrie de l'enfance et de l'adolescence*, 32, 183–195.
- Dumont, Louis. (1986). *Essays on individualism: Modern ideology in anthropological perspective*. Chicago: University of Chicago Press. (Original work published 1983)
- Duparc, François. (1988). Transfert latéral, transfert du négatif. *Revue française de psychanalyse*, 52 (4), 887–898.
- . (1992). Nouveaux développements sur l'hallucination négative et la représentation. *Revue française de psychanalyse*, 56 (1), 101–121.
- . (1995). *L'Image sur le divan*. Paris: L'Harmattan.
- . (1997). Hallucination négative, formes motrices et comportements autocalmants. *Cliniques Psychosomatiques*. Paris: Presses Universitaires de France.
- . (1998). *L'Élaboration en psychanalyse*. Bordeaux, France: L'Esprit du temps.

- Dupeu, Jean-Marc. (1986, July). L'analyse conventionnée, un analyseur pour la question du paiement en psychanalyse? *Psychanalysten*, 20, 35–49.
- Dupré, Ernest. (1925). *Pathologie de l'imagination et de l'émotivité*. Paris: Payot.
- Duyckaerts, François. (1990). Delboeuf-Ladame: un conflit paradigmatique. *Revue internationale d'histoire de la psychanalyse*, 3, 25–37.
- . (1992). *Joseph Delboeuf, philosophe et hypnotiseur*. Paris: Synthélabo.
- . (1993). “Les références de Freud à Delboeuf.” *Revue Internationale de Psychanalyse*, 6, 231–250.
- Dyer, Donald. (1991). *Cross-currents of Jungian thought: An annotated bibliography*. Boston-London: Shambhala.
- Eagle, Morris. (1993). Enactments, transference, and symptomatic cure: a case history. *Psychoanalytic Dialogues*, 3, 93–110.
- . (1995). The developmental perspectives of attachment and psychoanalytic theory. In S. Goldberg, R. Muir, J. Kerr (Eds.), *Attachment theory. Social, developmental and clinical perspectives* (pp. 123–153). Hillsdale, N.J.-London: The Analytic Press.
- . (2000). Repression, part 1 of 2. *Psychoanalytic Review*, 87, 1–38.
- Eagle, Morris. (2000). Repression, part 2 of 2. *Psychoanalytic Review*, 87, 161–188.
- Eckstein, Emma. (1904). *Die Sexualfrage in der Erziehung des Kindes*. Leipzig, Germany: Modernes Verlagsbureau, Curt Wigand.
- École Lacanienne de psychanalyse. (1991). *Le transfert dans tous ses errata and Pour une transcription critique des séminaires de Jacques Lacan*. Paris: E.P.E.L.
- Edelson, Marshall. (1972). Language and dreams: the interpretation of dreams revisited. *Psychoanalytic Study of the Child*, 27, 203–282.
- Eder, David. (1913). Das Stottern: eine Psychoneurose und seine Behandlung durch die Psychoanalyse. *Internationale Zeitschrift für ärztliche Psychoanalyse*, 1.
- . (1917). *War shock*. London: W. Heineman.
- . (1929). On the economics and the future of the super-ego. *International Journal of Psychoanalysis*, 10, 249–255.
- . (1930). Dreams—as resistance. *International Journal of Psychoanalysis*, 11, 40–47.
- . (1933). The Jewish phylacteries and other Jewish ritual observances. *International Journal of Psychoanalysis*, 14, 341–375.
- Edinger, Dora. (1963). *Bertha Pappenheim: Leben und Schriften*. Frankfurt: D. Edinger.
- . (1968). *Bertha Pappenheim: Freud's Anna O*. Highland Park, IL: Congregation Solel.
- Editors of *Frayages*. (1987). La naissance de la psychanalyse ... à Montréal. *Frayages*, 3.
- Editors of *Les temps modernes*. (1961). Maurice Merleau-Ponty. *Les temps modernes*, 184–185.
- Editors of *Ornicar?* (1977, December). Sur la passe. *Ornicar?*, 12–13.
- Eickhoff, Friedrich-Wilhelm. (1995). The formation of the German Psychoanalytical Association (DPV): Regaining the psychoanalytical orientation lost in the Third Reich. *International Journal of Psychoanalysis*, 76, 945–956.
- Eiguer, Alberto. (1987). *La Parenté fantasmatique*. Paris: Dunod.
- Eisler, Michael Joseph. (1921). Womb and birth saving phantasies in dreams. *International Journal of Psychoanalysis*, 2, 1, 65–67.
- Eisman, Aaron H. (1997). Obituary of Peter Blos. *International Journal of Psychoanalysis*, 78, p. 813–814.
- Eissler, Kurt R. (1953). On Hamlet. *Samiksa: 7*: 85–202.
- . (1955). *The Psychiatrist and the Dying Patient*. New York: International Universities Press.
- . (1962). *Leonardo da Vinci. Psychoanalytic Notes on the Enigma*. New York: International Universities Press.
- . (1962). On the metapsychology of the pre-conscious. *Psychoanalytic Study of the Child*, 17, 9–41.
- . (1963). *Goethe: A Psychoanalytic Study 1775–1786*. Two vols. Detroit: Wayne State University Press.
- . (1963). Notes on the psychoanalytic concept of cure. *Psychoanalytic Study of the Child*, 18, 424–463.
- . (1966). A note on trauma, dream, anxiety, and schizophrenia. *Psychoanalytic Study of the Child*, 21, 17–50.
- . (1968). Fortinbras and Hamlet. *American Imago*: 25: 199–223.
- . (1968). Freud's approach to literature — explaining and understanding. *Psychoanalytic Study of the Child*: 23: 141–77.
- . (1971). *Talent and genius*. New York: Quadrangle Books.
- . (1971). Death drive, ambivalence, and narcissism. *Psychoanalytic Study of the Child*, 26, 25–78.
- . (1975). The fall of man. *Psychoanalytic Study of the Child*: 30: 589–646.
- . (1977). Comments on penis envy and orgasm in women. *Psychoanalytic Study of the Child*, 32, 29–84.

- . (1986). *Freud as an expert witness: The discussion of war neuroses between Freud and Wagner-Jauregg* (Christine Trollope, Trans.). Madison, CT: International Universities Press. (Original work published 1979)
- . (1993). *Three Instances of Injustice*. New York: International Universities Press.
- . (1993). Erroneous interpretations of Freud's seduction theory. *Journal of the American Psychoanalytic Association*, 41, 571–584.
- Eissler, Kurt R. (Ed.). (1949). *Searchlights on Delinquency: New Psychoanalytic Studies*. New York: International Universities Press.
- Eissler-Selke, Ruth. (1946). About the historical truth in a case of delusion. *Psychoanalytic Review*, 33, 442–459.
- . (1949). Observations in a home for delinquent girls. *Psychoanalytic Study of the Child*, 3–4, 449–460.
- . (1976). *Gezeiten: Gedichte in deutscher Sprache*. New York: Abaris Books.
- Eissler-Selke, Ruth, Blitzstein, N. Lionel, and Eissler, Kurt R. (1950). Emergence of hidden ego tendencies during dream analysis. *International Journal of Psychoanalysis*, 31, 12–17.
- Eitingon, Max. (1924). Bericht über die Berliner psychoanalytische Poliklinik—Juni 1922—März 1924, VII-ter Internationalen psychoanalytischen Verlags-Kongress. *Internationale Zeitschrift für Psychoanalyse*, X (2), 229–241.
- Eizirik, Cláudio Laks. (1998). Porqué Fe.P.A.L.? *Boletín informativo de la Fe.P.A.L.* (2nd semester).
- Ekstein, Rudolph. (1968). In Fr. Alexander, S. Eisenstein, M. Grotjahn (dir.), *Psychoanalytic pioneers*. New York, London: Basic Books.
- Eliade, Mircea. (1963). *Patterns in comparative religion*. (Rosemary Sheed, Trans.). New York: World.
- Ellenberger, Henri F. (1952). La psychiatrie suisse. *Évolution psychiatrique*, 17, 139–158, 719–723.
- . (1954). Hermann Rorschach, M.D., 1884–1922: A biographical study. *Bulletin of the Menninger Clinic*, 18 (5), 173–219.
- . (1970). *The discovery of the unconscious. The history and evolution of dynamic psychiatry*. New York: Basic Books.
- . (1972). The story of “Anna O.”: a critical review with new data. In Micale, M.S. (Ed.). *Beyond the unconscious. Essays of Henry F. Ellenberger in the history of psychiatry*. Princeton, NJ: Princeton University Press, 1993.
- Ellman, Jon P. (1996). Analyst and patient midlife. *Psychoanalytic Quarterly*, 65, 353–371.
- Ellul, Jacques; Tosquelles, François; Corbin, Jean-François; et al. (1987). *La Genèse aujourd'hui*. Nantes, France: Arefpi.
- Embirikos, Andréas. (1950). Un cas de névrose obsessionnelle avec éjaculations précoces. *Revue française de psychanalyse*.
- Emde, Robert N. (1985). From adolescence to midlife: remodeling the structure of adult development. *Journal of the American Psychoanalytic Association*, 33(S), 59–112.
- Emde, Robert N. (Ed.). (1984). *Rene Spitz: dialogues from infancy*. Madison, CT: International Universities Press.
- Engelman, Edmund. (1976). *Bergasse 19, Sigmund Freud's home and offices, Vienna, 1938: The photographs of Edmund Engelman*. New York: Basic Books.
- . (1993). *Bergasse 19, Sigmund Freud's home and offices, Vienna, 1938, the photographs of Edmund Engelman*. New York: Basic Books.
- Enriquez, Eugène. (1983). *De la horde à l'état*. Paris: Gallimard.
- Enriquez, Micheline. (1971). D'un corps à l'autre: réflexions sur le masochisme. *Topique*, 7–8, 85–118.
- . (1974). Fantômes paranoïaques: différence des sexes, homosexualité, loi du père. *Topique*, 13, 23–58.
- . (1977). Analyse possible ou impossible. *Topique*, 18, 49–62.
- . (1977). Libres pensées. In Robert Barande (Ed.), *Comment l'interprétation vient au psychanalyste* (pp. 95–104). Paris: Aubier Montaigne.
- . (1980). Du corps de souffrance au corps en souffrance. *Topique*, 26, 5–27.
- . (1984). *Aux carrefours de la haine: Paranoïa, masochisme, apathie*. Paris: Éditions de l'Épi.
- . (1987). L'enveloppe de mémoire et ses trous. In Didier Anzieu et al. (Eds.). *Les enveloppes psychiques*. Paris: Dunod.
- . (1993). Le délire en héritage. In René Kaës et al. (Eds.), *Transmission de la vie psychique entre générations*. Paris: Dunod.
- . (1993). Incidence du délire parental sur la mémoire des descendants. In René Kaës et al. (Eds.), *Transmission de la vie psychique entre générations*. Paris: Dunod.
- Epstein, A. (1995). *Dreaming and other involuntary mentation. An essay in neuropsychiatry*. Madison, CT: International Universities Press.

- Erickson, Milton H. (1967). *Advanced techniques of hypnosis and therapy. (Selected papers of Milton Erickson edited by Jay Haley)*. New York, London: Grune & Stratton.
- Erikson, Erik H. (1950). *Childhood and society*. New York: Norton.
- . (1956). The problem of ego identity. *Journal of the American Psychoanalytic Association*, 56–121.
- . (1958). *Young Man Luther*. New York: W.W. Norton.
- . (1959). *Identity and the life cycle*. New York: International Universities Press.
- . (1964). *Insight and responsibility*. New York: W. W. Norton.
- . (1968). *Identity: Youth and crisis*. New York: Norton.
- . (1969). *Gandhi's truth*. New York: W.W. Norton.
- Ernest, Jones. (1950). Early development of female sexuality. In *Papers on psychoanalysis*. London: Bailliere, Tindall and Cox. (Original work published 1927)
- Errera, Giovanni. (1990). *Emilio Servadio: Dall'ipnosi alla psicoanalisi*. Florence: Nardini.
- Esman, Aaron H. (1990). *Essential papers on transference*. New York/London: New York University Press.
- . (1993). G. Stanley Hall and the invention of the adolescence. *Adolescent Psychiatry*, 19, 6–20.
- . (1998). What is “applied” in “applied” psychoanalysis?. *International Journal of Psychoanalysis*, 79, 741–756.
- . (2001). Obsessive-compulsive disorder: current views. *Psychoanalytical Inquiry*, 21, 145–156.
- Esman, Aaron H. (ed.). (1975). *The psychology of adolescence, essential readings*. New York: International Universities Press.
- Esquirol, Jean Étienne. (1838). *Des maladies mentales considérées sous les rapports médical, hygiénique et médico-légal*. Paris: J. B. Baillière.
- Estrada-Cristanto, T. (1997). Interview with Virgilio Santiago. November. Manila, Philippines. Unpublished.
- Lapuz, Lourdes. (1969). *A study of psychopathology*. Quezon City, Philippines: New Day Publications.
- Etchegoyen, R. Horacio. (1985). Identification and its vicissitudes. *International Journal of Psychoanalysis*, 66, 1, 3–18.
- Etchegoyen, R. Horacio, and Ahumada, Jorge L. (1990). Bateson and Matte Blanco: bio-logic and biologic. *International Review of Psycho-Analysis*, 17, 493–502.
- Etkind, Alexander. (1997). *Eros of the Impossible: The History of Psychoanalysis in Russia* (Noah Rubins and Maria Rubins, Trans.). Boulder, CO: Westview Press.
- Exner, John E., Jr. *The Rorschach: A comprehensive system*. New York: John Wiley, 1974.
- Exner, Sigmund. (1894). *Entwurf zu einer physiologischen Erklärung der psychischen Erscheinungen*. Vienna.
- Ey, Henri. (1939). Group of schizophrenics. *Encyclopédie médico-chirurgicale, volume Psychiatrie*. E.M.-C., fasc. 37-281-C-10.
- . (1939). Réflexions sur la valeur scientifique et morale de la psychanalyse: à propos de la thèse de Roland Dalbiez. *Encéphale*, 34, 189–220.
- . (1955). *Traité de psychiatrie clinique et thérapeutique*. Paris: E.M.-C.
- . (1973). *Traité des hallucinations*. Paris: Masson.
- Ey, Henri (Ed.). (1966). *L'Inconscient, 6e Colloque de Bonneval, 1960*. Paris: Desclée de Brouwer.
- Faber, M.D. (Ed.). (1970). *The design within: psychoanalytic approaches to Shakespeare*. New York: Science House.
- Fabre, Nicole. (1985). Les voies et les fins d'une analyse R.E.D. *Le Rêve-éveillé-analytique*. Toulouse, France: Privat.
- . (1986). *Des cailloux plein la bouche*. Paris: Fleurus.
- Færgeman, Poul. (1963). *Psychogenic psychoses*. London: Butterworths.
- Faimberg, Haydée. (1985). Le télescopage des générations, à propos de la généalogie de certaines identifications. *Revista de Psicoanálisis*, 42, 5, 1043–1056.
- . (1988). À l'écoute du télescopage des générations: pertinence psychanalytique du concept. *Topique*, 42, 223–238.
- Fain, Michel. (1969). Réflexions sur la structure allergique. *Revue française de psychanalyse*, 33 (2).
- . (1971). Prélude à la vie fantasmatique. *Revue française de psychanalyse*, 35 (2–3), 291–364.
- . (1983). Introduction. *Revue Française de Psychanalyse*, 67, 3, 707–716.
- . (1997). Névrose de caractère et mentalisation. *Rev. française de psychosomatique*, 11, 7–17.
- . (1997). Névrose de caractère et mentalisation. *Revue française de psychosomatique*, 11, 7–17.
- Fairbairn, Ronald. (1940e [1938]). Splitting of the ego in the process of defence. *SE*, 23: 271–278.

- . (1941). A revised psychopathology of the psychoses and psychoneuroses. *International Journal of Psychoanalysis*, 22, 250–279.
- . (1952). *Psychoanalytic studies of the personality*. London: Tavistock Publications.
- . (1952). A revised psychopathology of the psychoses and psychoneuroses. In *Psychoanalytic studies of the personality*. London: Tavistock Publications Ltd with Routledge, Kegan Paul, 1952. 28–58. (Reprinted from *International Journal of Psychoanalysis*, 22 (1941), 250–279.)
- . (1954). *An object-relations theory of the personality*. New York: Basic Books.
- . (1954). An object-relations theory of the personality. New York: Basic Books.
- . (1963). Synopsis of an object-relations theory of the personality. *International Journal of Psychoanalysis*, 44, 224–225.
- . (1994). *From instinct to self: Selected papers of W. R. D. Fairbairn: Vol. 1, Clinical and theoretical papers*. (David Scharff and Ellinor Fairbairn Birtles, Eds.). New Jersey: Jason Aronson.
- ald. (1994). *From instinct to self: Selected papers of W. R. D. Fairbairn: Vol. 2, Applications and early contributions*. (David Scharff and Ellinor Fairbairn Birtles, Eds.). New Jersey: Jason Aronson.
- . (1994). Endopsychic structure considered in terms of object relationships. In his *Psychoanalytic studies of the personality*. London: Tavistock Publications with Routledge and Kegan Paul. (Original work published 1952)
- . (1994). What is the superego? In David E. Scharff and Ellinor Fairbairn Birtles (Eds.), *From instinct to self: selected papers of W. R. D. Fairbairn*, Vol. 2, *Applications and early contributions*. Northvale, NJ: Jason Aronson. (Original work published 1929)
- Fallend, Karl, and Reichmayr, Johannes. (1992). Psychoanalyse, Film und Öffentlichkeit: Konflikte hinter den Kulissen. In Fallend and Reichmayr, (Eds.): *Siegfried Bernfeld oder Grenzen der Psychoanalyse* Frankfurt am Main: Stroemfeld-Nexus.
- Falzeder, Ernst. (1994). My grand-patient, my chief tormentor: A hitherto unnoticed case of Freud's and the consequences. *Psychoanalytic Quarterly*, 63, 297–331.
- . (1994). The threads of psycho-analytic filiations, or, psycho-analysis taking effect. In: *100 years of psycho-analysis. Contributions to the history of psycho-analysis* (Haynal, André) 194.
- Fanon, Frantz. (1965). *Studies in a dying colonialism* (Haakon Chevalier, Trans.). New York: Monthly Review Press. (Original work published 1958)
- . (1965). *The wretched of the earth* (Constance Farrington, Trans.). New York: Grove Press. (Original work published 1961)
- . (1967). *Black skin, white masks* (Charles Lam Markmann, Trans.). New York: Grove Press. (Original work published 1952)
- . (1967). *Toward the African revolution: political essays* (Haakon Chevalier, Trans.). New York: Grove Press. (Original work published 1964)
- Fast, Irene. (1999). Aspects of core gender identity. *Psychoanalytic Dialogues*, 9, 633–662.
- Faure, Franck. (1978). *La doctrine de Michael Bálint*. Paris: Payot.
- Favez, Georges. (1971). L'illusion et la désillusion dans la cure psychanalytique. *Nouvelle Revue de psychanalyse*, 4, 43–54. (Reprinted in his *Être psychanalyste* [1976])
- . (1974). La résistance dans l'analyse. *Nouvelle Revue de psychanalyse*, 10, 193–199. (Reprinted in his *Être psychanalyste* [1976])
- . (1976). *Être psychanalyste*. Paris: Dunod.
- Favreau, D. (1990). Le désir d'enfant dans l'imaginaire de l'enseignement. *Études psychothérapeutiques*, 1 (new series), 115–124.
- Favreau, Jean. (1964). Considérations sur les anomalies du comportement sexuel chez l'animal. In Abel Brion and Henri Ey (Eds.), *Psychiatrie animale* (pp. 265–281). Paris: Desclée, De Brouwer.
- . (1972). La formation des psychanalystes. *Études freudiennes*, 5–6, 51–72.
- Fechner, Gustav Theodor. (1848). Über das lustprinzip des handelns. *Zeitschrift für philosophie und philosophische kritik*, 19, 1–30; 163–194.
- . (1860). *Elemente der psychophysik*. Leipzig: Breitkopf und Härtel.
- . (1873). *Einige ideen zur schöpfer- und entwicklungsgeschichte der organismen*. Leipzig: Breitkopf und Härtel.
- Féder, Luis and Marco A. Dupont. (1987). Aspectos de la siembra y cosecha psicoanalítica mexicana. *Correio da Fe.P.A.L.*, 97.
- Feder, S., Karnel, R., and Pollock, G. (Eds.). (1990). *Psychoanalytic explorations in music*. Madison, CT: International Universities Press.
- Feder, Stuart. (Ed.). (1993). *Psychoanalytic explorations in music: Second series*. Madison, CT: International Universities Press.

- Federn, Ernst. (1972). Thirty-five years with Freud. *Journal of Clinical Psychology*, suppl. 32, 18–34.
- . (1982). Edoardo Weiss und der Beginn der psychoanalytischen Ichpsychologie. *Sigmund Freud House Bulletin*, 6 (1), 25–32.
- Federn, Paul. (1914). On dreams of flying. In Hendrik M. Ruitenbeek (Ed.), *The first freudians* (pp. 121–128). New York: Jason Aronson.
- . (1919). Zur psychologie der revolution: die vaterlose gesellschaft. Vienna: Anzengruber-Verlag.
- . (1926). *Ego-psychology and the psychoses*. E. Weiss (Ed.), New York: Basic Books, 1952.
- . (1926). *Ego-psychology and the psychoses*. E. Weiss (Ed.), New York: Basic Books, 1952.
- . (1926). Some variations in ego-feeling. *International Journal of Psychoanalysis*, 7, 434–444.
- . (1928). Narcissism in the structure of the ego. *International Journal of Psychoanalysis*, 9, 401–419.
- . (1933). Sándor Ferenczi. *International Journal of Psychoanalysis*, 14, 467.
- . (1934). The analysis of psychotics. *International Journal of Psychoanalysis*, 15, 209–214.
- . (1952). *Ego-psychology and the psychoses* (Edoardo Weiss, Ed.). New York: Basic Books. (Original work published 1926)
- Federn, Paul, and Meng, Heinrich. (1926). *Das psychoanalytische volksbuch* (2 vols.). Stuttgart: Hippocrates.
- . (1928). *Das psychoanalytische Volksbuch*. Stuttgart: Hippokrates.
- Fédida, Pierre. (1964). Le structuralisme en psychopathologie: histoire, langage et relation. *Évolution Psychiatrique*, 29, 1, 85–129.
- . (1977). *Corps du vide et espace de séance*. Paris: J.-P. Delarge.
- . (1978). *L'absence*. Paris: Gallimard.
- . (1978). L'identité. L'économie du théorique. Autour du texte sur "les constructions dans l'analyse." *Psychanalyse à l'Université*, 3 (11), 437–444.
- . (1986). Le contre-transfert en question. *Psychanalyse à l'Université*, 11 (41), 19–30.
- . (1992). *Crise et contre-transfert*. Paris: Presses Universitaires de France.
- . (1995). *Le site de l'étranger*. Paris: Presses Universitaires de France.
- . (2000). *Par où commence le corps humain: retour sur la régression*. Paris: Presses Universitaires de France.
- . (2001). *Des bienfaits de la dépression: éloge de la psychothérapie*. Paris: Odile Jacob.
- Fédida, Pierre, and Guyotat, Jean (Eds.). (1986). *Mémoires et transferts*. Paris: Écho-Centurion.
- Feldman, Michael. (1994). Projective identification in fantasy and enactment. *Psychoanalytical Inquiry*, 14, 423–440.
- . (1997). Projective identification: the analyst's involvement. *International Journal of Psychoanalysis*, 78, 227–243.
- . (2000). Some views on the manifestation of death instinct in clinical work. *International Journal of Psychoanalysis* 81, 53–66.
- Felman, Shoshana (Ed.). (1982). *Literature and psychoanalysis. The question of reading: otherwise*. Baltimore: Johns Hopkins University Press.
- Fenichel, Otto. (1928). The clinical aspect of the need for punishment. *International Journal of Psychoanalysis*, 9, 47–70.
- . (1931). The pre-genital antecedents of the Oedipus complex. *International Journal of Psychoanalysis*, 12, 138–170.
- . (1934). *Outline of clinical psychoanalysis*. New York: W.W. Norton.
- . (1941). *Problems of psychoanalytic technique* (David Brunswick, Trans.). New York: Psychoanalytic Quarterly.
- . (1941). *Problems of psychoanalytic technique* (David Brunswick, Trans.). New York: The Psychoanalytic Quarterly.
- . (1945). *The psychoanalytic theory of neurosis*. New York: Norton.
- . (1951). On the psychology of boredom. In *Selected papers of Fenichel*. New York: W. W. Norton.
- . (1953–1954). *The collected papers of Otto Fenichel*. New York: W. W. Norton.
- . (1953). Respiratory introjection. In *The collected papers, first series*. New York, W.W. Norton.
- . (1982). Reflections on training and theory (1942). *International Review of Psychoanalysis*, 9, 155–162.
- . (1998). 119 Rundbriefe (1934–1945). (2 vols.). Frankfurt am Main: Stroemfeld.
- Ferenczi, Sándor. (1911). On the organisation of the psycho-analytic movement. In: *Final contributions to the problems and methods of psycho-analysis* (Michael Balint, Ed.). 299–307. Brunner/Mazel: New York 1955.
- . (1915). Die psychiatrische schule von Bordeaux über die psychoanalyse. *Internationale Zeitschrift für Artzliche Psychoanalyse*, 3, 352–369.
- . (1916). Introjection and transference. In his *Contributions to Psychoanalysis* (Ernest Jones, Trans.;

- pp. 30–80.). Boston: Richard G. Badger. (Original work published 1909)
- . (1916). Stages in the development of the sense of reality. In *Sex in psycho-analysis*. Boston: Richard C. Badger.
- . (1921). The further development of the “active technique” in psychoanalysis. In *Selected Writings* (pp. 187–204). London: Penguin, 1999.
- . (1923). Der traum vom “gelehrten Säugling.” *Internationale Zeitschrift für ärztliche Psychoanalyse*, 9, 70.
- . (1924). *Thalassa. Versuch einer Genitaltheorie*. Leipzig and Vienna: Internationaler Psychoanalytischer Verlag; (1938). *Thalassa: A Theory of Genitality* (Henry Alden Bunker, Trans.). Albany, NY: Psychoanalytic Quarterly.
- . (1926). Contra-indications to “active” psychoanalytical technique. In *Further contributions to the theory and technique of psycho-analysis* (J. Rickman, Comp. and J. I. Suttie, et al., Trans.). London: Hogarth.
- . (1926). Le problème de l’affirmation du déplaisir. In his *Oeuvres Complètes* (Vol. 3, pp. 389–428). Paris: Payot
- . (1926). Psycho-analytical observations on tic. *The selected papers of Sándor Ferenczi, M.D.*, vol. 2: *Further contributions to the theory and technique of psycho-analysis*. (John Rickman, Comp.; Jane Isabel Suttie et al., Trans.). New York: Basic Books. (Original work published 1921)
- . (1926). The phenomena of hysterical materialization: thoughts on the conception of hysterical conversion and symbolism. In his *Further contributions to the theory and technique of psycho-analysis*. London: Hogarth Press. (Original work published 1919)
- . (1927). Ein kleiner Hahnemann. In his *Bausteine zur Psychoanalyse*: Vol. 2, *Praxis* (pp. 185–195). Leipzig: Internationaler psychoanalytischer Verlag. (Original work published 1913)
- . (1928). The elasticity of psycho-analytic technique. In *The selected papers of Sándor Ferenczi, Vol. 3*. (pp. 87–101). (Michael Balint, Ed.; Eric Mosbacher, et al, Trans.). New York: Basic Books.
- . (1929). The unwelcome child and the death instinct. *International Journal of Psychoanalysis*, 10, 125–129.
- . (1930). The principle of relaxation and neo-catharsis. *International Journal of Psychoanalysis*, 11, 428–443.
- . (1931). Child analysis in the analysis of adults. In *The selected papers of Sándor Ferenczi, Vol. 3* (pp. 126–42). (Michael Balint, Ed.; Eric Mosbacher, et al, Trans.). New York: Basic Books.
- . (1932). Repetition in analysis worse than original trauma. In *The selected papers of Sándor Ferenczi, Vol. 3*. (Michael Balint, Ed.; Eric Mosbacher, et al, Trans.). New York: Basic Books, 268.
- . (1933 [1932]). Confusion of tongues between adults and the child: The language of tenderness and passion. *International Journal of Psychoanalysis*, 30, (1949), 225–230. In *Final Contributions to the Problems and Methods of Psycho-Analysis*. London: Hogarth, 1955.
- . (1933 [1955]). *Notes and fragments. Final contributions to the problems and methods of psycho-analysis*. (Eric Mosbacher and others, Trans.). New York: Basic Books.
- . (1936). Male and female—Psychoanalytic reflections on the “Theory of Genitality”60.
- . (1949). Confusion of tongues between adults and the child: the language of tenderness and of passion. *International Journal of Psychoanalysis*, 30, 225–230. (Original work published 1933)
- . (1949). Notes and fragments (1930–32). *International Journal of Psychoanalysis*, 30, 231–242.
- . (1949). Psychoanalysis and education. *International Journal of Psychoanalysis*, 30, 220–224. (Original work published 1920)
- . (1950). Nakedness as a means for inspiring terror. In *Further Contributions to the Theory and Technique of Psycho-Analysis* (pp. 329–31; Jane Isabel Suttie, et al, Trans.). London: The Hogarth Press. (Original work published 1919)
- . (1952). The psychological analysis of dreams. In *First Contributions to Psycho-Analysis* (pp. 94–131; Ernest Jones, Trans.). London: The Hogarth Press. (Original work published 1909)
- . (1955). On the pevision of The Interpretation of Dreams. *Selected Papers of Sándor Ferenczi, III* (Eric Mosbacher, et al, Trans.; pp. 238–43.). New York: Basic Books. (Original work published 1931)
- . (1955). Selected papers of Sandor Ferenczi. (Vol. 3, Michael Bálint, Ed.). New York: Basic Books.
- . (1955). The problem of the termination of the analysis. In *The selected papers of Sándor Ferenczi. Vol. III (Final contributions to the problems and methods of psychoanalysis)*. (Michael Balint, Ed.; Eric Mosbacher, et al, Trans.). New York: Basic Books. (Original work published 1927)
- . (1968). *Thalassa: A theory of genitality*. (Henry Alden Bunker, Trans.). New York: W. W. Norton. (Original work published 1924)

- . (1968). Le développement du sens de la réalité et ses stades. *O.C., Psychanalyse, Vol. 2*, 51–64. Paris: Payot. (Original work published 1913)
- . (1968). Suggestion et psychanalyse. In his *Psychanalyse I, Œuvres complètes* (Vol. 1: 1908–1912; pp. 233–42). Paris: Payot. (Original work published 1912)
- . (1974). Difficultés techniques d’une analyse d’hystérie. *Oeuvres complètes (Psychanalyse, Vol. 3)*. Paris: Payot. (Original work published 1919)
- . (1974). Névrose des dimanches. *Oeuvres complètes (Psychanalyse, Vol. 3)*. Paris: Payot. (Original work published 1919)
- . (1980). Two types of war neuroses. In *Further contributions to the theory and technique of psycho-analysis* (pp. 124–141) (John Rickman, Ed.; Jane Isabel Suttie et al, Trans.). New York: Brunner/Mazel. (Original work published 1916/1917)
- . (1982). Le traitement psychanalytique du caractère. In his *Œuvres complètes. Vol. 4: Psychanalyse, 1927–1932*. Paris: Payot. (Original work published 1928)
- . (1988). *The clinical diary of Sándor Ferenczi. January–October 1932* (Judith Dupont, Ed., and Michael Balint and Nicola Zarday Jackson, Trans.). Cambridge, MA: Harvard University Press. (Original work published 1985 [1932])
- . (1996). Le traumatisme psychique. In his *Oeuvres complètes. Psychanalyse* (Vol. 4, pp. 82–97). Paris: Payot. (Original work published 1932)
- . (1999). On forced fantasies. In *Selected writings* (pp. 222–230). London: Penguin. (Original work published 1924)
- . (1999). Technical difficulties in a case of hysteria. In *Selected writings* (pp. 151–158). London: Penguin. (Original work published 1919)
- . (1999). The elasticity of psychoanalytic technique. In *Selected writings* (pp. 255–268). London: Penguin. (Original work published 1928).
- . (1999). The further development of the “active technique” in psychoanalysis. In *Selected writings* (pp. 187–204). London: Penguin. (Original work published 1921)
- . (2000). On masochistic orgasm. In *Final contributions to the problems and methods of psychoanalysis*. (p. 248–49; Michael Balint, Ed; Eric Mosbacher, Trans.). London: Karnac Books. (Original work published 1931)
- Ferenczi, Sándor, and Hollós, István. (1922). *Zur Psychoanalyse der paralytischen Geistesstörung*. Wien: Internationaler Psychoanalytischer Verlag.
- Ferenczi, Sándor, and Rank, Otto. (1925). *The development of psychoanalysis* (Caroline Newton, Trans.). New York: Nervous and Mental Disease Publishing Co. (Original work published 1924)
- Ferenczi, Sándor, Abraham, Karl, Simmel, Ernst, and Jones, Ernest. (1921). *Psychoanalysis and the war neuroses* (The International Psychoanalytical Library, No.2). London: International Psychoanalytical Press.
- Ferenczi, Sándor, et al. (1921). *Psycho-analysis and the war neuroses*. Vienna: International Psycho-analytical Press.
- Ferreira, Antonio J. (1980). Double lien et délinquance. *Changements systémiques en thérapie familiale*. Paris: E.S.F. (Original work published 1960)
- Ferri, Enrico. (1967). *Criminal sociology* (Joseph I. Kelly and John Lisle, Trans.). New York: Agathon. (Original work published 1917)
- Ferro, Antonino. (1997). *L’Enfant et le Psychanalyste: La question de la technique dans la psychanalyse des enfants*. Ramonville-Saint-Agne, France: Érès.
- Finck, Jean. (1982). *Thomas Mann et la psychanalyse*. Paris: Les Belles Lettres.
- Fine, Alain. (1984). Quelques réflexions et interrogations autour de la recto-colite hémorragique. In M. Fain and C. Dejours (Eds.), *Corps malade et Corps érotique* (pp. 59–76). Paris: Masson.
- . (1993). Laios pédophile et infanticide. *Revue française de psychanalyse*, 57 (2), 515–524.
- . (1995). L’opérateur comme négatif de la réalité psychique. *Revue française de psychanalyse*, 59, (1), 173–186.
- Fink, Paul. (1970). Correlation between “actual” neurosis and Masters and Johnson. *Psychoanalytic Quarterly*, 39, 38–51.
- Finzi, Roberto. (1998). *Anti-semitism* (Maud Jackson, Trans.). New York: Interlink. (Original work published 1997)
- Firestein, Stephen K. (1974). Terminasion de l’analyse. *Revue française de psychanalyse*, 44, 2.
- Fischer, Eugenia. (1992). Czechoslovakia. In P. Kutter (Ed.), *Psychoanalysis international, a guide to psychoanalysis throughout the world, vol. 1, Europe* (pp. 34–49). Stuttgart-Bad Cannstatt: Frommann-Holzboog, 34–49.
- Fischer, René. (1975). Zur Geschichte der psychoanalytischen Bewegung in der Tschechoslowakei. *Psyche*, 29, 12.
- Fisher, Charles P. (1996). Panel Report: Psychoanalysis in the Pacific Rim. *International Journal of Psychoanalysis*, 77, 373–377.



- Flagey, Danièle. (1973). L'inhibition intellectuelle. *Revue française de psychanalyse*, 36, 717–798.
- Flammer, J.-A. (1995). *Le psychanalyste: Ch. Odier*. In C. Müller, (Ed.), *Portraits de psychiatres romands* (pp. 103–157). Lausanne, France: Payot.
- Flaubert, Gustave. (1954). *Dictionary of accepted ideas* (Jacques Barzun, Trans.). Norfolk, CT: New Directions Books.
- Flem, Lydia. (1982). L'archéologie chez Freud : destin d'une passion et d'une métaphore. *Nouvelle revue de psychanalyse*, 26, pp. 71–94
- Fleming, Joan, and Benedek, Terese F. (1983). *Psychoanalytic supervision: a method of clinical teaching*. New York : Basic Books.
- Fliess, Robert. (1953). Countertransference and counteridentification. *Journal of the American Psychoanalytic Association*, 1, 268–284.
- . (1956). Phylogenetic vs. ontogenetic experience. *International Journal of Psychoanalysis*, 37, 46–60.
- Fliess, Wilhelm. (1977). *Les Relations entre le nez et les organes génitaux féminins présentées selon leurs significations biologiques*. (P. Ach and J. Guir, Trans.). Paris: Le Seuil. (Original work published 1897)
- Florence, Jean. (1978). *L'Identification dans la théorie freudienne*. Brussels: Publications des facultés, Université Saint-Louis.
- Flournoy, Henri. (1920). Dreams on the symbolism of water and fire. *International Journal of Psychoanalysis*, 1 (3), 245–255
- . (1922). Çiva androgyne: contribution à l'étude psychanalytique des principaux symboles et attributs d'une divinité hindoue. *Archives de psychologie*, 18.
- . (1932). Le caractère scientifique de la psychanalyse. *Revue française de psychanalyse*, 5 (2), 190–200.
- . (1949). *Erreurs et dignité de la pensée humaine*. Paris: Le Mont-Blanc.
- Flournoy, Olivier. (1986). *Théodore et Léopold: de Théodore Flournoy à la psychanalyse*. Neuchâtel: La Baconnière.
- Flournoy, Théodore. (1890). *Métaphysique et psychologie*. Geneva: Georg.
- . (1900). *Des Indes à la planète Mars*. Paris: Le Seuil.
- . (1902). Nouvelles observations sur un cas de somnambulisme avec glossolalie. *Les archives de psychologie*, 1.
- . (1906). Miss Frank Miller, Quelques faits d'imagination créatrice subconsciente. *Archives de psychologie*, V, 36–51.
- . (1911). *Esprits et médiums*. Geneva: Kundig and Fischbacher.
- . (1994). *From india to the planet mars: A case of multiple personality with imaginary languages*. Princeton, NJ: Princeton University Press. (Original work published 1901)
- Fodor, N. (1949). *The search for the beloved: a clinical investigation of the trauma of birth and prenatal conditioning*. New York: Hermitage Press.
- Fonagy, Ivan. (1970). *Les Bases pulsionnelles de la phonation*, *Revue française de psychanalyse*, 34 (1), 101–136.
- Fonagy, Ivan. (1983). *La Vive Voix: essais de psychophonétique*. Paris: Payot.
- Fonagy, Peter, and Target, Mary. (1998). Mentalization and the changing aims of child psychoanalysis. *Psychoanalytic Dialogues*, 8, 87–114.
- Fonagy, Peter, et. al. (1993). Aggression and the psychological self. *International Journal of Psychoanalysis*, 74, 471–486.
- Fonagy, Peter; Cooper, Arnold, and Wallerstein, Robert S. (Eds.). (1999). *Psychoanalysis on the move: the work of Joseph Sandler*. London, New York: Routledge.
- Fonagy, Peter; Steele, Miriam; Moran, George S.; et al. (1993). Measuring the ghost in the nursery: An empirical study of the relation between parents' mental representations of childhood experiences and their infants' security of attachment. *Journal of the American Psychoanalytic Association* 41, 957–89.
- Fordham, Michael. (1969). *Children as individuals*. London: Hodder & Stoughton.
- . (1978). *Jungian psychotherapy: A study in analytical psychology*. Chichester, U.K.: Wiley.
- Fornari, Franco. (1966). *Nuovi orientamenti della psicoanalisi*. Milan: Feltrinelli.
- . (1974). *The psychoanalysis of war* (Alenka Pfeifer, Trans.). Garden City, NY: Anchor Press. (Original work published 1970.)
- . (1975). *Genitalità e cultura*. Milan: Feltrinelli.
- . (1976). *Simbolo e codice: dal processo psicoanalitico all'analisi istituzionale*. Milan: Feltrinelli.
- . (1979). *I fondamenti di una teoria psicoanalitica del linguaggio*. Torino: Boringhieri, 1979.
- . (1981). *Il codice vivente: femminilità e maternità nei sogni delle madri in gravidanza*. Torino: Boringhieri, 1981.

- . (1984). *La riscoperta dell'anima*. Bari: Laterza.
- . (1985). *Affetti e cancro*. Milan: Cortina.
- Forrester, John. (1980). *Language and the Origins of Psychoanalysis*. New York: Columbia University Press.
- Fossey Luc, Papiernik, E., and Bydlowsky Monique. (1997). Postpartum blues: A clinical syndrome and predictor of postnatal depression. *Journal of Psychosomatic Obstetric Gynecology*, 18, 17–21.
- Fosshage, James L. (1988). Dream interpretation revisited. *Progress in Self Psychology*, 3, 161–175.
- . (1998). On aggression: its forms and functions. *Psychoanalytical Inquiry*, 18, 45–54.
- Foucault, Michel. (1973). *The order of things: An archaeology of the human sciences*. New York: Vintage Books. (Original work published 1966)
- . (1994). *The birth of the clinic: an archaeology of medical perception*. (A. M. Sheridan Smith, Trans.). New York: Vintage Books. (Original work published 1963)
- Foulkes, Siegmund Heinrich. (1964). *Therapeutic group analysis*. New York: International Universities Press.
- Fowler, C., and Hilsenroth, M. (1999). Some reflections on self-mutilation. *Psychoanalytic Review*, 86, 721–732.
- Fowler, J.C., et al. (2000). The inner world of self-mutilating borderline patients. *Bulletin of the Menninger Clinic*, 64, 365–385.
- Frécourt, Jean. (1988, July). Le psychanalyste est payé. *Psychanalyses*, 28, 3–16.
- Fraiberg, Selma. (1982). Pathological defenses in infancy. *Psychoanalytic Quarterly*, 51 (4), 612–635.
- Franco da Rocha, Francisco. (1928). A psicologia de Freud. *Revista brasileira de psicanálise*, 1, 1.
- . (1930). *A doutrina de Freud* (2nd ed.). São Paulo, Brazil: Companhia Nacional.
- Frank, A., and Muslin, H. (1967). The development of Freud's concept of primal repression. *Psychoanalytic Study of the Child*, 22, 55–76.
- Frank, George. (1996). Conflict and deficit: two theories or one? *Psychoanalytical Psychology*, 13, 567–570.
- . (2000). Transference revisited/transference revisioned. *Psychoanalysis and Contemporary Thought*, 23, 459–478.
- Frankiel, Rita V. (Ed.). (1994). *Essential papers on object loss*. New York: New York University Press.
- Frankl, Viktor. (1972). *Man's search for meaning: An introduction to logotherapy*. Boston: Beacon Press.
- . (1997). *Recollections: An autobiography*. New York: Plenum Press.
- Franklin, Girard. (1990). The multiple meanings of neutrality. *Journal of the American Psychoanalytic Association*, 38, 195–220.
- Franz, Marie-Louise von. (1971). *The Inferior Function, in Lectures on Jung's Typology*. Zürich: Spring.
- Franz, Marie-Louise von, and Hillman, James (1971). *Lectures on Jung's Typology*. New York: Spring.
- Frazer, James G. (1910). *Totemism and exogamy*. New York: Walker.
- . (1951). *The golden bough; a study in comparative religion*. London: Macmillan. (Original work published 1890–1915)
- Freedman, Norbert, et. al. (2002). Desymbolization: concept & observations on anorexia & bulimia. *Psychoanalysis and Contemporary Thought*, 25, 165–200.
- Freeman, Derek. (1983). *Margaret Mead and Samoa: The making and unmaking of an anthropological myth*. Cambridge, MA: Harvard University Press.
- Freeman, Lucy. (1972). *The story of Anna O*. New York: Walker.
- Freire de Garbarino, Mercedes, et al. (1995). Uruguay. In Peter Kutter (Ed.), *Psychoanalysis international: A guide to psychoanalysis throughout the world*, vol. 2 (pp. 174–185). Stuttgart, Germany: Frommann-Holzboog.
- Freire de Garbarino, Mercedes. (1988). Breve historia de la Asociación psicoanalítica del Uruguay. *Revista uruguaya de psicoanálisis*, 68, 3–10.
- Frémont, Marguerite. (1994). *La Vie du Dr René Allendy (1889–1942)*. Montpellier: Climats.
- Freud, Anna. (1923). The relation of beating fantasies to a daydream. *International Journal of Psychoanalysis*, 4 89–102.
- . (1928). *Introduction to the technic of child analysis* (L. Pierce Clark, Trans.). New York: Nervous and Mental Disease Publishing Co. (Original work published 1927)
- . (1936). *Collected writings*, New York: International Universities Press.
- . (1936). A form of altruism. In *Writings of Anna Freud* (Vol. 2, pp. 122–134).
- . (1937). *The Ego and the Mechanisms of Defence* (Cecil Baines, Trans.). London: Hogarth. (Original work published 1936)
- . (1946 [1926–45]). *The psycho-analytical treatment of children*. Translated by Nancy Procter-Grigg (Parts I and 2). London: Imago; New York: International Universities Press.
- . (1946). *The psychoanalytical treatment of children. Technical lectures and essays*. London: Imago.

- . (1953). Some remarks on infant observation. *Psychoanalytic Study of the Child*, 8, 9–19.
- . (1959). *The psychoanalytical treatment of children: Technical lectures and essays*. New York: International Universities Press.
- . (1966). *Collected Writings*. New York: International Universities Press.
- . (1966). *The ego and the mechanisms of defence*. New York, International Universities Press. (Original work published 1936)
- . (1966). Obsessional neurosis: a summary of Congress views. *International Journal of Psychoanalysis*, 47, 116–122.
- . (1968). “Acting out.” *International Journal of Psychoanalysis*, 49 (2–3), 165–170.
- . (1976). Remarks on problems of psychoanalytic training. *Writings (of Anna Freud)*, 8, 186–192.
- . (1977). Fears, anxieties, and phobic phenomena. *Psychoanalytic Study of the Child*, 32, 85–90.
- . (1979). Personal memories of Ernest Jones. *International Journal of Psychoanalysis*, 60, 285–287.
- . (1980). *Normality and pathology in childhood, assessments of development*. New York: International Universities Press. (Original work published 1965)
- . (1980). Introduction. In Sigmund Freud: *The analysis of a phobia in a five-year-old boy*. Frankfurt am Main: S. Fischer.
- . (1981). Insight. *Psychoanalytic Study of the Child*, 36, 241–250.
- Freud, Anna, and Burlingham, Dorothy. (1943). *Infants without families*. London: G. Allen and Unwin.
- Freud, Martin. (1958). *Sigmund Freud: Man and father*. New York: J. Aronson.
- Freud, W. Ernest. Infant observation: its relevance to psychoanalytic training. *Psychoanalytic Study of the Child*, 30, 75–94.
- Frichet, Anne. (1998). Intimité perdue, intimité naissante: l'étrange prématuré en quête de familier. In *Le bébé, l'intime, et l'étrange*. Paris: Érès.
- Friedländer, Kate. (1940). On the longing to die. *International Journal of Psychoanalysis*, 21, 416–426.
- . (1941). Children's books and their function in latency and pre-puberty. *Internationale Zeitschrift für Psychoanalyse*, 26.
- . (1945). Formation of the anti-social character. *Psychoanalytic Study of the Child*, 1, 189.
- . (1949). Neurosis and home background, a preliminary report. *Psychoanalytic Study of the Child*, 3–4, 423.
- Friedländer, Saul (1978). *History and psychoanalysis: An inquiry into the possibilities and limits of psychohistory* (Susan Suleiman, Trans.). New York: Holmes & Meier. (Original work published 1975)
- Friedman, Lawrence. (1968). Drives and knowledge: a speculation. *Journal of the American Psychoanalytic Association*, 16, 81–94.
- . (1995). Psychic reality in psychoanalytic theory. *International Journal of Psychoanalysis*, 76, 25–28.
- . (2002). What lies beyond interpretation, and is that the right question? *Psychoanalytic Psychology*, 19, 540–551.
- Friedman, Robert. (1988). *Male Homosexuality. A Contemporary Psychoanalytic Perspective*. New Haven and London: Yale University Press
- . (2001). Psychoanalysis and human sexuality. *Journal of the American Psychoanalytic Association*, 49, 1115–1132.
- Friedman, Susan Stanford. (2002). *Analysing Freud: letters of HD, Bryher and their circle*. New York: New Directions.
- Friedrich, Volker. (1988). Letters of an emigrant: The psychoanalyst Clara Happel to her son Peter, 1936–1945. *Revue internationale d'histoire de la psychanalyse*, 1, 323–348.
- Frink, Horace. (1918). *Morbid fears and compulsions*. New York: Dodd Mead.
- Fromm, Erich. (1963). *The dogma of Christ and other essays on religion, psychology, and culture*. New York: Henry Holt. (Original work published 1930)
- Fromm-Reichmann, Freida. (1950). *Principles of intensive psychotherapy*. Chicago: University of Chicago Press.
- Furer, Manuel (1977). Psychoanalytic dialogue: Kleinian theory today. *Journal of the American Psychoanalytic Association*, 25, 371–385.
- Furman, Erna. (1982). Mothers have to be there to be left. *Psychoanalytic Study of the Child*, 37, 15–28.
- . (1990). Play and work in early childhood. *Child Analysis*, 1, 60–76.
- . (1996). On motherhood. *Journal of the American Psychoanalytic Association*, 44(S), 429–448.
- . (2002). Transference and countertransference in child analysis. *Child Analysis*, 13, 113–188.
- Gödde, Günther. (2003). *Mathilde Freud. Die älteste Tochter Sigmund Freud in Briefen und Selbstzeugnissen Gieben*. Giessen: Psychosozial-Verlag.
- Göring, Matthias H. (1942). Jahresbericht 1941 des Deutschen Instituts für psychologische Forschung und Psychotherapie und Hinweise anlässlich der Mitglie-

- derversammlung am 28.3.1942. *Zentralblatt für Psychotherapie*, 14 (1–2), 62–77.
- Gabbard, Glen O. (1991). Technical approaches to transference hate: Borderline patients. *International Journal of Psychoanalysis*, 72, 625–638.
- . (1993). On hate in love relationships: The narcissism of minor differences revisited. *Psychoanalytic Quarterly*, 62, 229–238.
- . (1995). The early history of boundary violations in psychoanalysis. *Journal of the American Psychoanalytical Association*, 43, 1115–1136.
- . (1995). Countertransference: the emerging common ground. *International Journal of Psychoanalysis*, 76, 475–486.
- . (1996). *Love and hate in the analytic setting*. Northvale, NJ: Aronson, Inc.
- . (2001). Psychoanalytic approaches to treatment of obsessive-compulsive disorder. *Psychoanalytical Inquiry*, 21, 208–221.
- Gabbard, Glen O., and Lester, Eva. (1995). *Boundaries and boundary violations in psychoanalysis*. New York: Basic Books.
- Gabbard, Krin, and Gabbard, Glen O. (1987). *Psychiatry and the cinema*. Chicago: University of Chicago Press.
- Gaddini, Eugenio. (1969). On imitation. *International Journal of Psychoanalysis*, 50, 475–484.
- . (1972). Aggression and the pleasure principle: Towards a psychoanalytic theory of aggression. *International Journal of Psychoanalysis*, 53 (2), 191–198.
- . (1974). I settanta anni di Emilio Servadio: Un tributo. *Rivista di psicoanalisi*, 20 (2), pp. 5–13.
- . (1987). Notes on the mind-body question. *International Journal of Psychoanalysis*, 68 (3), 315–330.
- . (1989). *Scritti*. Milan, Italy: Raffaello Cortina.
- . (1992). *A psychoanalytic theory of infantile experience: conceptual and clinical reflections* (Adam Limentani, Ed.). London: Tavistock Publications.
- Gaddini, Renato. (1993). On autism. *Psychoanalytical Inquiry*, 13, 134–143.
- Gadelius, Bror. (1934). *Tro och helbräddagörelse jämte en kritisk studie av psykoanalysen*. Stockholm: Hugo Gebers.
- Gaillard, Christian. (1995). *Jung*. Paris: Presses Universitaires de France.
- Galenson, Eleanor, and Roiphe, Herman. (1980). The preoedipal development of the boy. *Journal of the American Psychoanalytical Association*, 28, 805–828.
- Galvão, Luis Almeida Prado. (1967). Notas para a história de psicanálise em São Paulo. *Revista brasileira de psicanálise*, 1 (1), 46–68.
- Gamwell, Lynn, and Wells, Richard (Eds.). (1989). *Sigmund Freud and art: His personal collection of antiquities*. London: Freud Museum.
- Gantheret, François. (1975). Quelques éléments de recherche sur la place du biologique dans la théorie psychanalytique. *Psychanalyse à l'Université*, 1 (December 1), 97–104.
- . (1984). L'impensable maternel et les fondements maternels du penser. In *Incertitude d'Éros*, Paris: Gallimard.
- Garcia de la Hoz, Antonio. (1985). Freud en castellano. *Libros* 36, 3–9.
- Garcia, Emanuel E. (1990). Somatic interpretation in a transference cure: Freud's treatment of Bruno Walter. *International Review of Psycho-Analysis*, 17, 83–88.
- Gardiner, Muriel M. (1971). *The Wolf-Man by the Wolf-Man*. New York: Basic Books.
- . (1976). *The deadly innocents: Portraits of children who kill*. New York: Basic Books.
- . (1983). *Code name "Mary": Memoirs of an American woman in the Austrian underground*. New Haven and London: Yale University Press.
- . (1983). The wolf man's last years. *Journal of the American Psychoanalytical Association*, 31, 867–897.
- Gardner, Dorothy E. M. (1969). *Susan Isaacs*. London: Methuen Education.
- Garfinkel, Barry D.; Froese, A., and Hood, J. (1982). Suicide attempts in children and adolescents. *American Journal of Psychiatry*, 139, 10, 1257–1261.
- Garma, Angel. (1931). Die realität und das es in der schizophrenie. *Internationale Zeitschrift für Psychoanalyse*.
- . (1940). *Psicoanálisis de los sueños*. Buenos Aires: El Ateneo.
- . (1970). *Neuvas aportaciones al psicoanálisis de los sueños*. Buenos Aires: Paidós.
- . (1985). *The psychoanalysis of dreams*. New York: Jason Aronson. (Original work published 1940)
- . (1990). *Tratado mayor del psicoanálisis de los sueños*. Madrid: Contenido.
- Garofalo, Raffaele. (1891). *Criminologia*. Turin: Fratelli Bocca.
- Gauchet, Marcel. (1992). *L'Inconscient cérébral*. Paris: Le Seuil.
- Gauchet, Marcel, and Swain, Gladys. (1997). *Le Vrai Charcot*. Paris: Calmann-Lévy.

- Gauld, Alan. (1992). *A history of hypnotism*. Cambridge: Cambridge University Press.
- Gay, Peter (1985). *Freud for historians*. New York, Oxford University Press.
- . (1987). *A Godless Jew: Freud, atheism, and the making of psychoanalysis*. New Haven, CT: Yale University Press.
- . (1988). *Freud: A life for our time*. New York: W.W. Norton.
- . (1990). *Reading Freud: Explorations and entertainments*. New Haven: Yale University Press.
- Gay, Volney P. (1982). Semiotics as metapsychology: the status of repression. *Bulletin of the Menninger Clinic*, 46, 489–506.
- Geahchan, Dominique. (1986). *Temps et Désir du psychanalyste*. Paris: InterÉditions.
- Gediman, Helen K. (1984). Actual neurosis and psychoneurosis. *International Journal of Psychoanalysis*, 65, 191–202.
- Gedo, John E. (1975). Forms of idealization in the analytic transference. *Journal of the American Psychoanalytic Association*, 23, 485–506.
- Geets, Claude. (1981). *Winnicott*. Paris: Éditions Universitaires J.-P. Delarge.
- Gehl, Raymond H. (1965). Dépression et claustrophobie. *Revue française de psychanalyse*, 29 (2–3), 233–255.
- Gehrie, M.J. (1992). Panel: Methodology of applied psychoanalysis: key issues. *Journal of the American Psychoanalytic Association*, 40, 239–244.
- Geissmann, Claudine and Pierre. (1984). *L'Enfant et sa Psychose*. Paris: Dunod.
- . (1992). *A history of child psychoanalysis*. New York: Routledge.
- Geleerd, Elisabeth R. (1958). Borderline states in childhood and adolescence. *The Psychoanalytic Study of the Child*, 13, 279–295.
- . (1963). Evaluation of Melanie Klein's narrative of a child analysis. *International Journal of Psychoanalysis*, 44, 493–506.
- . (1964). Child analysis: Research, treatment and prophylaxis. *Journal of the American Psychoanalytic Association*, 44, 242–258.
- Gergely, György. (2000). Reapproaching Mahler: New perspectives on normal autism, symbiosis, splitting and libidinal object constancy from cognitive developmental theory. *Journal of the American Psychoanalytic Association*, 48, 1197–1228.
- Gerlach, A. (1995). China. In P. Kutter (Ed.). *Psychoanalysis International: A guide to Psychoanalysis throughout the world* (Vol. 2, pp. 94–102). Stuttgart-Bad Cannstatt: Fromman-Holzboog.
- Gessain, Robert. (1957). “Vagina dentata” dans la clinique et la mythologie. *Psychanalyse*, 3, 247–295.
- Ghorbal, Mohamed. (1981). La personnalité maghrébine, psychogénèse. *Information psychiatrique*, 57 (4), 441–449.
- Gibeault, Alain. (1985). Travail de la pulsion et représentations: Représentation de chose et représentation de mot. *Revue française de psychanalyse*, 49, 3, 753–772.
- . (1989). Destins de la symbolisation. *Revue française de psychanalyse*, 53 (6), 1493–1617.
- . (1996). Réalité psychique et réalité externe dans le processus psychanalytique: 3e Conférence de la FEP sur l'analyse d'enfant et d'adolescent, Amsterdam, 1996. *Bulletin de la Fédération européenne de psychanalyse*, 47, 65–70.
- . (1997). La Fédération européenne a trente ans: passé, présent, avenir. *Psychanalyse en Europe*, 49.
- Gibeault, Alain, and Kestemberg, Evelyne. (1981). Le personnage tiers. *Cahiers du Centre pour la psychanalyse et la psychothérapie*, 3, 1–84.
- Gicklhorn, Josef, and Gicklhorn, Renée. (1960). *Sigmund Freuds akademische Laufbahn*. Vienna-Innsbruck: Urban & Schwarzenberg.
- Gicklhorn, Renée. (1976). *Sigmund Freud und der Onkeltraum. Dichtung und Wahrheit*. Horn/Ndösterr: F. Berger.
- . (1976). La famille Freud à Freiberg. *Études freudiennes*, 11–12, p. 231–238.
- Gide, André. (1953). *The Journals of André Gide*. (Justin O'Brien, Trans.). New York: Knopf.
- Gifford, Sanford, rep. (1964). Panel: Repetition compulsion. *Journal of the American Psychoanalytic Association*, 12, 632–649.
- Gifford, Sanford. (1978). Psychoanalysis in Boston: Innocence and experience. In G. E. Gifford Jr. (Ed.), *Psychoanalysis, psychotherapy and the New England medical scene, 1894–1944* (pp. 325–345). New York: Science History Publications.
- Gill, Merton M. (1961). David Rapaport, 1911–1960. *Bulletin of the American Psychoanalytic Association*, 17, 755–759.
- . (1988). Metapsychology revisited. *Annual of Psychoanalysis*, 16, 35–48.
- Gill, Merton M. (Ed.). (1967). *The collected papers of David Rapaport*. New York: Basic Books.

- Gill, Merton, et. al. (1954). *The initial interview in psychiatric practice*. New York: International Universities Press.
- Gillespie, William H. (1964). The psychoanalytic theory of sexual deviation with special reference to fetishism. In Ismond Rosen (Ed.), *The pathology and treatment of sexual deviation* (pp. 123–145). London: Oxford University Press.
- Gillett, Eric. (1997). Revising Freud's structural theory. *Psychoanalysis and Contemporary Thought*, 20, 471–500.
- Gillibert, Jean. (1975). Postface to Tausk, Oeuvres psychanalytiques. Paris: Payot.
- . (1977). De l'autoérotisme. XXXVII Congrès des psychanalystes de langues romanes. *Revue française de psychanalyse*, 41, 5–6.
- . (1982). De l'objet pulsionnel de la pulsion d'emprise. *Revue française de psychanalyse*, 46 (6), 1211–1244.
- . (1985). *Le psychodrame de la psychanalyse*. Paris: Champ Vallon.
- Gillibert, Jean, and Wilgowicz, Perel (Eds.). (1993). *L'Ange exterminateur*. Proceedings of the Colloque de Cerisy. Brussels: Éditions Universitaires de Bruxelles.
- Gilman, Sander L. (1984). Jewish jokes: Sigmund Freud and the hidden language of the Jews. *Psychoanalysis and Contemporary Thought*, 7, 591–644.
- Gilmore, Karen. (1998). Cloacal anxiety in female development. *Journal of the American Psychoanalytic Association*, 46, 443–470.
- Gimbutas, Marija. (1989). *The language of the goddess*. New York: Harper & Row.
- Giovacchini, Peter L. (1984). The psychoanalytic paradox: the self as a transitional object. *Psychoanalytic Review*, 71, 81–104.
- Girard, Claude. (1984). La part transmise. XLIIIe Congrès des psychanalystes de langues romanes. *Revue française de psychanalyse*, 48, 1.
- Glick, Robert, and Bone, Stanley, eds. (1990). *Pleasure beyond the pleasure principle. The role of affect in motivation, development, and adaptation* (Vol. 1). New Haven/London: Yale University Press.
- Glover, Edward. (1932). On the aetiology of drug addiction. *International Journal of Psychoanalysis*, 13, 298–328.
- . (1933). *War, sadism and pacifism*. London: Allen and Unwin.
- . (1945). Eder as a psychoanalyst. In Joseph Burton Hobman (Ed.), *David Eder: memoirs of a modern pioneer*. London: Victor Gollancz.
- . (1945). Examination of the Klein system of child psychology. *Psychoanalytic Study of the Child*, 1, 75–118.
- . (1950). *Freud or Jung*. London: Allen and Unwin.
- . (1955). *The technique of psycho-analysis*. London: Bailliere, Tindall and Cox.
- . (1956). *On the early development of mind. Selected papers*. London: Imago Publishing. Re-issued 1970, New York: International Universities Press.
- . (1960). *The roots of crime*. London: Imago Publishing. Re-issued 1970, New York: International Universities Press.
- Glover, Edward, and Brierley, Marjorie. (1940). *An investigation of the technique of psycho-analysis*. London: Bailliere, Tindall and Cox.
- Glover, James. (1924). Notes on an unusual form of perversion. *International Journal of Psychoanalysis*, 8, 10–24.
- . (1925). Contribution to a symposium on the conception of sexuality. *British Journal of Psychology*, 5, 3.
- Goethe, Johann Wolfgang von. (1992). *Faust, a Tragedy, Part One*. (Martin Greenberg, Trans.). New Haven, CT: Yale University Press. (Original work published 1808)
- . (1998). *Faust, Part Two*. (Martin Greenberg, Trans.). New Haven, CT: Yale University Press. (Original work published 1883)
- Golan, Shmuel. (1959). Collective education in the kibbutz. *Psychiatry*, 22, 167–177.
- Goldberg, Arnold. (1988). *A fresh look at psychoanalysis: The view from self psychology*. Hillsdale, NJ: The Analytic Press.
- . (1993). Sexualization and desexualization. *Psychoanalytic Quarterly*, 62, 383–399.
- . (1995). *The problem of perversion. The view from self psychology*. New Haven, CT: Yale University Press.
- . (1998). Self psychology since Kohut. *Psychoanalytic Quarterly*, 67, 240–255.
- Goldstein, Joseph; Freud, Anna, and Solnit, Albert J. (1973). *Beyond the best interests of the child*. New York: The Free Press.
- Golse, Bernard. (1983). Pour une psychopathologie ou une psychogenèse des tics de l'enfant: une revue de la littérature. *Actualités psychiatriques*, 1, 51–56.
- . (1992). *Le développement affectif et intellectuel de l'enfant*. Paris: Masson.

- . (1992). Cauchemars, rêves et processus de pensée. *Psychiatrie de l'Enfant*, 37, 2, 395–413.
- González Velásquez, Mario. (1993). *La cohesión del self*. Bogotá: Ed. Guadalupe Ltda.
- Goody, Esther. (1982). *Parenthood and social reproduction: fostering and occupational roles in west Africa*. Cambridge, UK: Cambridge University Press.
- Gordan, Joan (Ed.). (1976). *Margaret Mead: the complete bibliography, 1925–1975*. The Hague: Mouton.
- Gori, Roland. (1996). *La preuve par la parole: sur la causalité en psychanalyse*. Paris: Presses Universitaires de France.
- Gorney, J. (1998). Twinship, vitality, pleasure. *Progress in Self Psychology*, 14, 85–106.
- Gougoulis, Nicolas, and Kapsambélis, Vassilis. (1996). Recherches sur le concept freudien des névroses actuelles. *Topique*, 61, 493–502.
- Graf, Max. (1911). *Richard Wagner im "Fliegenden Holländer," Ein Beitrag zur Psychologie des künstlerischen Schaffens*. Leipzig-Vienna: F. Deuticke.
- . (1942). Reminiscences of Professor Sigmund Freud. *Psychoanalytic Quarterly*, 11, p. 465–476.
- . (1947). *From Beethoven to Shostakovich: The Psychology of the Composing Process*. New York: Philosophical Library.
- Graham, Frank W. (1965). Obituary: Dr. Roy Coupland Winn. *International Journal of Psychoanalysis*, p. 616.
- Gramaglia, Giancarlo. (1992). Notes sur la psychanalyse italienne entre les deux guerres, 1915–1945. *Revue internationale d'histoire de la psychanalyse*, 5, 129–142.
- . (1995). *Discorsi/scritti di psicoanalisi*. Turin, Italy: Il Laboratorio.
- Grand, Stanley. (1995). Classic revisited: Stone's "The widening scope of indications for psychoanalysis". *Journal of the American Psychoanalytic Association*, 43, 741–764.
- . (2002). Action in the psychoanalytic situation: Reflections on its relation to internal and external reality. *Psychoanalytical Psychology*, 19, 254–280.
- Granel, Julio A. (1987). Considerations on the capacity to change, the clash of identifications and having accidents. *International Review of Psycho-Analysis*, 14, 483–490.
- Granoff, Wladimir. (1975). *Filiations. L'avenir du complexe d'Oedipe*. Paris: Les Éditions de Minuit.
- . (1976). *La pensée et le féminin*. Paris: Minuit.
- Granoff, Wladimir, and Perrier, François. (1964). Le problème de la perversion chez la femme et les idéaux féminins. *Psychanalyse*, 7, 141–199.
- . (1979). *Le désir et le féminin*. Paris: Aubier.
- Granoff, Wladimir, and Rey, Jean-Michel. (1983). *L'Occulte, objet de la pensée freudienne*. Paris: Presses Universitaires de France.
- Gray, Paul. (1987). On the technique of analysis of the superego: an introduction. *Psychoanalytic Quarterly*, 56, 130–154.
- . (1992). Memory as resistance, and the telling of a dream. *Journal of the American Psychoanalytic Association*, 40, 307–326.
- . (2000). Analysis of conflicted drive derivatives of aggression. *Journal of the American Psychoanalytic Association*, 48, 219–236.
- Green, André. (1961). Chimiothérapies et psychothérapies. *Encéphale*, 50 (1), 29–101.
- . (1963). La psychanalyse devant l'opposition de l'histoire et de la structure. *Critique*, 194, 649–662.
- . (1965). Obsessions et psychonévrose obsessionnelle. In *Encyclopédie médico-chirurgicale, volume Psychiatrie*. Paris: E.M.-C., fasc. 37-370-A-10: 1–10; B-10: 1–5; C-10: 1–6; D-10: 1–14.
- . (1968). Sur la mère phallique. *Revue française de psychanalyse*, 32, 1, 1–38.
- . (1969). Othello, une tragédie de la conversion: Magie noire et magie blanche. In his *Un oeil en trop: le complexe d'Oedipe dans la tragédie*. (pp. 109–164). Paris: Éditions de Minuit.
- . (1971). La projection: de l'identification projective au projet. In *La folie privée*. Paris: Gallimard.
- . (1972). Note sur les processus tertiaires. *Revue française de Psychanalyse*, 36, 3, 407–410.
- . (1973). *Le discours vivant: La conception psychanalytique de l'affect*. Paris: Presses Universitaires de France.
- . (1976). Un, autre, neutre: valeurs narcissiques du même. *Narcissisme de vie, narcissisme de mort*. Paris: Minuit, 31–79.
- . (1977). L'hallucination négative, note pour un addendum pour un traité des hallucinations. *L'Évolution Psychiatrique*, 62 (2), 645–656, special number.
- . (1979). *The tragic effect: The Oedipus complex in tragedy*. (Alan Sheridan, Trans.). Cambridge and New York: Cambridge University Press. (Original work published 1969)
- . (1979). Le silence du psychanalyste. *Topique*, 23, p. 5–25.
- . (1982). Après-coup, l'archaïque. *Nouvelle revue de psychanalyse*, 26, 195–216.
- . (1984). Le langage dans la psychanalyse. In Green, André, Diatkine, René, Jabes, Edmond, Fain,

- Michel, and Fonagy, Ivan, *Langages*. Paris: Belles Lettres.
- . (1985). Réflexions libres sur la représentation de l'affect. *Revue Française de Psychanalyse*, 69, 3, 773–788.
- . (1987). *On private madness*. Guilford, CT: International Universities Press.
- . (1989). Pulsions de mort, narcissisme négatif, fonction désobjectalisante. In his *La pulsion de mort*. Paris: Presses Universitaires de France.
- . (1990). *Le complexe de castration*. Paris: Presses Universitaires de France.
- . (1991). Penser l'originaire. *Topique*, 49.
- . (1992). Le double double: Ceci et cela. In his *La déliaison: Psychanalyse, anthropologie et littérature* (pp. 299–311). Paris: Belles Lettres.
- . (1993). Analité primaire dans la relation anale. *La Névrose obsessionnelle*. Paris: Presses Universitaires de France.
- . (1994). *Somatisation, psychanalyse et science du vivant*. Paris: Eschel.
- . (1995). *La causalité psychique. Entre nature et culture*. Paris: Odile Jacob.
- . (1995). *Propédeutique. La métapsychologie revisitée*. Paris: L'Or d'Atalante.
- . (1995). La mort du moi et le destin des objets: objet de la perversion, objet de la quiétude. In *Propédeutique: la métapsychologie revisitée* (pp. 279–284). Seyssel: Champ Vallon. (Original work published 1989)
- . (1997). *Les chaînes d'Éros*. Paris: Odile Jacob.
- . (1999). *The fabric of affect in the psychoanalytic discourse* (Alan Sheridan, Trans.). London and New York: Routledge. (Original work published 1973)
- . (1999). *The work of the negative* (Andrew Weller, Trans.). New York: Free Association. (Original work published 1993)
- . (1999). The death drive, negative narcissism and the disobjectalising function. In *The work of the negative* (pp. 81–88). (A. Weller, Trans.). London: Free Association Books.
- . (2000). *The chains of eros: the sexual in psychoanalysis* (Luke Thurston, Trans.). London: Rebus. (Original work published 1997)
- . (2001). *Life narcissism, death narcissism* (Andrew Weller, Trans.). London and New York: Free Association Books. (Original work published 1983)
- . (2001). The dead mother. In his *Life narcissism, death narcissism* (Andrew Weller, Trans.). New York: Free Association Books. (Original work published 1983)
- Green, Maurice. (1964). *Interpersonal psychoanalysis. The selected papers of Clara Thompson*. New York, Basic Books.
- Greenacre, Phyllis. (1941). The predisposition to anxiety. In her *Trauma, Growth and Personality* (pp. 27–82). New York: W. W. Norton, 1952.
- Greenacre, Phyllis. (1945). Pathological weeping. *Psychoanalytic Quarterly*, 14 62–75.
- . (1952). The biological economy of birth. In her *Trauma, growth and personality*. New York: Norton. (Original work published 1945)
- . (1953). Certain relationship between fetishism and the faulty development of the body image. *Psychoanalytic Study of the Child*, 8, 79–98.
- . (1955). *Swift and Carroll, A psychoanalytic study of two lives*. New York: International Universities Press.
- . (1957). The childhood of the artist: Libidinal phase development and giftedness. In *Emotional growth, psychoanalytic studies of the gifted and a great variety of other individuals* (2 vols., p. 479–504). New York: International Universities Press.
- . (1958). Early physical determinants in the development of the sense of identity. *Journal of the American Psychoanalytic Association*, 6, 612–627.
- . (1958). The impostor. *Psychoanalytic Quarterly*, 27 (3), 359–382.
- . (1960). Further notes on fetishism. *Psychoanalytic Study of the Child*, 15, 191–207.
- . (1960). Regression and fixation. *Journal of the American Psychoanalytic Association*, 8, 703–723.
- . (1964). Nature of inspiration: I. A special consideration regarding the phallic phase. *Journal of the American Psychoanalytic Association*, 12, 6–31.
- . (1966). Problems of training analysis. *Psychoanalytic Quarterly*, 35, 540–567.
- . (1969). The fetish and the transitional object. *Psychoanalytic Study of the Child*, 24, 144–164.
- . (1973). The primal scene and the sense of reality. *Psychoanalytic Quarterly*, 42, 10–41.
- Greenberg, Jay. (1991). *Oedipus and Beyond: A Clinical Theory*. Cambridge, MA/London: Harvard University Press.
- Greenberg, Stephen, and Mitchell, Jay (1983). *Object relations in psychoanalytic theory*. Cambridge, MA, and London: Harvard University Press.
- Greenson, Ralph R. (1958). Variations in classical psychoanalytic technique. *International Journal of Psychoanalysis*, 29, 200–201.



- . (1960). Empathy and its vicissitudes. *International Journal of Psychoanalysis*, 41, 418–424.
- . (1965). The working alliance and the transference neurosis. *Psychoanalytic Quarterly*, 34, 155–181.
- Greenson, Ralph R. (1967). *The technique and practice of psychoanalysis* (Vol. 1). New York: International Universities Press.
- . (1967). *The technique and practice of psychoanalysis*. New York: International Universities Press.
- . (1970). The exceptional position of the dream in psychoanalytic practice. *Psychoanalytic Quarterly*, 39, 519–549.
- . (1978). *Explorations in Psychoanalysis*. New York, International Universities Press.
- . (1978). The “real” relationship between the patient and the psychoanalyst. In *Explorations in Psychoanalysis* (p. 425–440). New York: International Universities Press. (Original work published 1971)
- Gregerson, M. Banks. The curious 2000-year case of asthma. *Psychosomatic Medicine*, 62, 816–827.
- Greon-Prakken, Han. (1993). The psychoanalytical society and the analyst, with special reference to the history of the Dutch Psychoanalytical Society 1917–1947. In Greon-Prakken and Ladan (Eds.), *Dutch Annual of Psychoanalysis, 1993*. Amsterdam-Lisse, Swets & Zeitlinger, p. 13–37.
- Gressot, Michel. (1979). *Le royaume intermédiaire*. Paris: Presses Universitaires de France.
- Gribinksi, Michel. (1994). Avant-propos. In *Analyse ordinaire, analyse extraordinaire*. vol. 1. Paris: Gallimard, “Les varia de la Nouvelle Revue de psychanalyse,” p. 7–11.
- Grinberg, León. (1962). On a specific aspect of countertransference due to the patient’s projective identification. *International Journal of Psychoanalysis*, 43, 436–440.
- . (1965). Deux sortes de culpabilité: leurs relations avec les aspects du deuil normal et pathologique. *Revue française psychanalyse*, 29, 2–3.
- . (1968). “On acting out and its role in the psychoanalytic process.” *International Journal of Psychoanalysis*, 49, 171–178.
- . (1983). *Culpabilité et dépression*. Paris: Les Belles Lettres.
- Grinberg, León; Sor, Darío, and Tabak de Bianchedi, Elizabeth. (1993). *New introduction to the work of Bion* (rev. ed.). Northvale, NJ: Jason Aronson.
- Grinker, R. R., and Spiegel, J. P. (1934). *War neuroses in North Africa, the Tunisian campaign September–May 1943*. New York: Josiah Macy Jr. Foundation.
- Grinstein, Alexander, (1968). *On Sigmund Freud’s dreams*. Detroit: Wayne State University Press.
- Grinstein, Alexander. (1990). *Freud at the Crossroads*. New York: International Universities Press.
- Groddeck, Georg. (1917). *Psychische Bedingtheit und psychoanalytische Behandlung organischer Leiden*. Leipzig: S. Hirzel.
- . (1923). *Das Buch vom Es: Psychoanalytische Briefe an eine Freundin*. Leipzig: Internationaler Psychoanalytischer Verlag; München: Fischer Taschenbuch, 1984. *The Book of the It*. Washington: Nervous and Mental Disease Publishing Co., 1928. *The Book of the It: Psychoanalytic Letters to a Friend* (V. M. E. Collins, Trans.). New York: Funk and Wagnalls, 1950.
- . (1928). *The book of the it: Psychoanalytic letters to a friend*. Washington, DC: Nervous and Mental Disease. (Original work published 1923)
- . (1933). *Der Mensch als Symbol: unmassgebliche Meinungen über Sprache und Kunst*. Leipzig: Internationaler psychoanalytischer Verlag.
- . (1951). *The world of man* (V. M. E. Collins, Trans.). New York: Funk & Wagnalls Co.
- . (1977). *Ça et Moi. Lettres à Freud, Ferenczi et quelques autres* (R. Lewinter. Trans.). Paris: Gallimard.
- . (1977). *The meaning of illness: selected psychoanalytic writings* (Gertrud Mander, Trans.). London: Hogarth Press.
- Groen-Prakken, Han. (1986). Une organisation psychanalytique européenne: le quand, le comment et le pourquoi: un aperçu historique de la fondation et du développement de la F.E.P. *Psychanalyse en Europe*, 26–27, 11–65.
- . (1993). The psychoanalytical society and the analyst, with special reference to the history of the Dutch Psychoanalytical Society 1917–1947. In *Dutch Annual of Psychoanalysis, 1993* (p. 13–37). Amsterdam-Lisse: Swets and Zeitlinger.
- . (1997). Vers une Fédération européenne de psychanalyse: le développement du mouvement psychanalytique en Europe centrale et de l’Est, 1987–1996. *Psychanalyse en Europe*, 48 (1), 5–25.
- Grollman, Earl A. (1965). *Judaism in Sigmund Freud’s World*. New York: Appleton Century.
- Gross, Otto. (2000). *Collected works*. (Lois Madison, Ed. and Trans.). Hamilton, NY: Mindpiece.
- Grosskurth, Phyllis. (1986). *Melanie Klein. Her world and work*. London: Hodder & Stoughton.
- . (1991). *The secret ring*. Toronto: McFarlane, Walter & Ross.

- Grossman, Carl M., and Grossman, Sylva. (1965). *The wild analyst: the life and work of Georg Groddeck*. New York: Braziller.
- Grossman, William I. (1989). Review of A phylogenetic fantasy: overview of the transference neuroses. *Journal of the American Psychoanalytic Association*, 37, 853–858.
- Grossman, William I., Stewart, Walter A. (1976). Penis envy: from childhood wish to developmental metaphor. *Journal of the American Psychoanalytic Association*, 24, 193–212.
- Grosz, Ronald. (1992). *Das jüdische element in Freuds psychoanalyse*. Dissertation zur Erlangung des Doktorgrades der Philosophie an der Grund- und Integrationswissenschaftlichen Fakultät der Universität Wien. Vienna, dissertation.
- Grote, Louis R., and Meng, Heinrich. (1934). Über interne und psychotherapeutische Behandlung der endogenen Magersucht. *Schweizerische medizinische Wochenschrift*, 15: 7.
- Grotjahn, Martin. (1966). Georg Groddeck, the untamed analyst. In Fr. Alexander, S. Eisenstein, M. Grotjahn (eds.), *Psychoanalytic pioneers* (p. 308–320). New York-London: Basic Books.
- Grotstein, James S. (1981). *Do I dare disturb the universe?* Beverly Hills, CA: Caesura Press.
- . (1981). *Splitting and projective identification*. New York: Aronson.
- . (1994). Projective identification and countertransference: a brief commentary on their relationship. *Contemporary Psycho-Analysis*, 30, 578–592.
- Grotstein, James S., and Rinsley, Donald (Eds.). (1994). *Fairbairn and the origins of object relations*. London: Free Association Press and New York: The Guilford Press.
- Grubrich-Simitis, Ilse. (1987). Einleitung. In Sigmund Freud, *GW, Nachtragsband*, Frankfurt am Main: S. Fischer.
- . (1987). Metapsychology and metabiology. In Sigmund Freud, *A phylogenetic fantasy*. (p. 73–107). Cambridge, MA: Belknap Press, 1987.
- . (1987). Trauma oder trieb. Trieb und trauma. Lektionen aus Sigmund Freuds phylogenetischer phantasie von 1915. *Psyche*, 41, 992–1023.
- . (1989). Nachtrag 1989 zu den “erläuterungen zur edition.” *Studienausgabe* (Vol. 1, p. 32). Frankfurt-am-Main: Fischer.
- . (1995). *Urbuch der Psychoanalyse. Hundert Jahre Studien über Hysterie von Josef Breuer und Sigmund Freud*. Frankfurt am Main: S. Fischer.
- . (1996). *Back to Freud's texts: Making silent documents speak* (Philip Slotkin, Trans.). New Haven, CT: Yale University Press. (Original work published 1993)
- . (2000). *Metamorphosen der Traumdeutung*. In Jean Starobinski, Ilse Grubrich-Simitis, and M. Solms, (Eds.). *Hundert Jahre Traumdeutung von Sigmund Freud*. Frankfurt am Main: Fischer Taschenbuch Verlag.
- Grunbaum, Adolph. (1984). *The foundations of psychoanalysis. A philosophical critique*. Berkeley: University of California Press.
- . (1993). *Validation in the clinical theory of psychoanalysis: A study in the philosophy of psychoanalysis*. Madison, CT: International University Press.
- Grunberger, Béla, and Chasseguet-Smirgel, Janine (Eds.). (1978). *L'Identification: l'autre c'est moi*. Paris: Tchou.
- Grunberger, Béla, and Chasseguet-Smirgel, Janine. (1980). *La cure psychanalytique. Sur le divan*. Paris: Tchou.
- Grunberger, Béla. (1971). *Le narcissisme. Essais de psychanalyse*. Paris: Payot.
- . (1979). *Narcissism: psychoanalytic essays*. (Joyce S. Diamanti, Trans.). New York: International Universities Press. (Original work published 1971)
- . (1989). *Narcisse et Anubis*. Paris: Des femmes.
- Grunberger, Bela, and Desuant, Pierre. (1997). *Narcissisme, christianisme, antisémitisme*. Paris: Actes Sud.
- Guedeney, Nicole, Fermanian, J., Guelfi, J.D., Delour, M. (1995). Premiers résultats de la traduction de l'Edinburgh post-natal depression scale sur une population parisienne. *Devenir*, 7 (2), 69–90.
- Guex, Germaine (1950). *La névrose d'abandon*. Paris: Presses Universitaires de France. (2nd ed.: *Le syndrome d'abandon*, 1973.)
- Guignard, Florence. (1996). *Au vif de l'infantile*. Paris: Delachaux and Niestlé.
- . (1997). *Épître à l'objet*. Paris: Presses Universitaires de France.
- Guilbert, Yvette. (1902). *La vedette*. Paris: H. Simonis Empis.
- . (1926). *Autre temps, autres chants*. Paris: Robert Laffont.
- . (1992). *47 enregistrements originaux de 1897 à 1934*. Paris: E.P.M.
- Guilhot, Jean, and Marie-Aimée Guilhot. (1987). *Analyse, Activation et Action thérapeutique. Vers un intégralisme analytique et prospectif*. Paris: E. S. F.

- Guillaumin, Jean. (1972). Le rêveur et son rêve. *Revue française de psychanalyse*, 37 (1–2), 5–39.
- . (1983). *Psyché*. Paris: Presses Universitaires de France.
- . (1987). *Entre blessure et cicatrice*. Seyssel: Éditions Champ Vallon.
- . (1997). D'objet, sujet devenir. *Revue française de psychanalyse*, 61 (2), 497–508.
- Guillemain, Bernard. (1959). *Maryse Choisy ou l'Amoureuse Sagesse*. Paris: C.A.M.C. Hachette.
- Guntrip, Harry. (1973). Science, psychodynamic reality, and autistic thinking. *Journal of the American Academy of Psychoanalysis*, 1, 3–22.
- Gutheil, Thomas G., and Gabbard, Glen O. (1993). The concept of boundaries in clinical practice: Theoretical and risk-management dimensions. *American Journal of Psychiatry*, 150, 188–196.
- Guttman, Samuel A. (1984). *The concordance to "The standard edition of the complete psychological works of Sigmund Freud"* (2nd ed.). New York: International Universities Press.
- . (1985). In memoriam Muriel M. Gardiner, M.D. (1901–85). *The Psychoanalytic Study of the Child*, 40, 1–7.
- Gutton, Philippe. (1991). *Le pubertaire*. Paris: Presses Universitaires de France.
- Guy-Gillet, Geneviève. (1984). Inceste et sacrifice. *Cahier de L'Herne*, 46, Jung. Paris: L'Herne, pp. 64–80.
- Guyomard, Patrick. (1992). *La jouissance du tragique, Antigone, Lacan et le désir de l'analyste*. Paris: Aubier.
- . (1992). *La jouissance du tragique: Antigone, Lacan et le désir de l'analyste*. Paris: Aubier.
- Guyotat, Jean, and Fédida, Pierre. (1985). *Événement et psychopathologie*. Lyon: Simep.
- Haag, Geneviève. (1991). Nature de quelques identifications dans l'image du corps. Hypothèses. *Journal de la psychanalyse d'enfant* 10, 73–92.
- Haag, Michel. (1984). *À propos des premières applications françaises de l'observation régulière et prolongée d'un bébé dans sa famille selon la méthode de Mrs. Esther Bick: des surprises profitables*. Privately published.
- Haarstrick, Franz Rudolf. (1994). Die Entwicklung des Gutachterverfahrens in der Psychotherapie. *Arbeitskreis Deutschen Gesellschaft für Psychoanalyse, Psychotherapie, Psychosomatik und Tiefenpsychologie/Vereinigung Analytischer Kinder—und Jugendlichen—Psychoterapeuten*, 4.
- Haag, Michel, and Haag, Geneviève. (1995). L'observation des nourrissons selon Esther Bick (1901–1983). et ses applications. *Information psychiatrique*, 1, 7–17.
- Hachet, Pascal. (1995). *Les psychanalystes et Goethe*. Paris: L'Harmattan.
- Hadley, June L. (1992). The instincts revisited. *Psychoanalytic Inquiry*, 12, 396–418.
- Haenel, H. (1908). Literaturkritik. *Neurologisches Zentralblatt*, 1, 39–40.
- Halberstadt-Freud, Hendrika. (1996). Studies on hysteria one hundred years on: a century of psychoanalysis. *International Journal of Psychoanalysis*, 77, 983–996.
- Hale, Nathan G., Jr. (1971). *Freud and the Americans: The beginnings of psychoanalysis in the United States, 1876–1917*. New York: Oxford University Press.
- . (1971). *James Jackson Putnam and psychoanalysis*. Cambridge, MA: Harvard University Press.
- . (1995). *The rise and crisis of psychoanalysis in the United States: Freud and the Americans, 1917–1985*. New York: Oxford University Press.
- Halfron, Olivier, Ansermet, François, and Blaise, Pierrehumbert. (Eds.). (2000). *Filiations psychiques*. Paris: Presses Universitaires de France.
- Hall, G. Stanley. (1904). *Adolescence: its psychology and its relations to physiology, anthropology, sociology, sex, crime, religion and education*. New York: Appleton.
- . (1917). *Jesus, the Christ, in the light of psychology*. Garden City, New York: Doubleday.
- . (1923). *Life and confessions of a psychologist*. New York: Appleton.
- Hall, Murray G. (1985). *Österreichische Verlags-geschichte 1918–1938*. Vienna: H. Böhlau.
- Hamilton, Victoria. (1982). *Narcissus and Oedipus—The children of psychoanalysis*. London: Routledge and Kegan Paul Ltd.
- Hamilton, Virginia. (1996). *The analyst's preconscious*. Hillsdale, NJ: Analytic Press.
- Hannah, Barbara. (1976). *Jung, His Life and Work: A Biographical Memoir*. New York: Putnam.
- Hantouche, Élie. (1995). Troubles obsessionnels compulsives. In *Encyclopédie médico-chirurgicale, Psychiatrie*. Paris: E.M.-C., fasc. 37–370–A–10, p. 1–14.
- . (1997). Obsession. *Les Objets de la psychiatrie* (p. 389–390). Paris: L'Esprit du temps.
- Hanyal, André, and Falzeder, Ernst. (1991). Healing through love? a unique dialogue in the history of psychoanalysis. *Free Associations*, 21 (2), 1–20.
- Happel, Clara. (1923). Onanieersatzbildungen. *Internationale Zeitschrift für Psychoanalyse*, 9, 206–209.

- . (1926). Communication: Notes on an analysis of a case of paederasty. *International Journal of Psychoanalysis*, 7, 229–236.
- . (1927). Der Mann in der Kloake. *Zeitschrift für psychoanalytische Pädagogik*, 2, 86–89.
- Hardy-Baylé, Marie-Christine. (1996). Troubles de l'information et troubles mentaux. In Daniel Widlöcher (Ed.), *Traité de psychopathologie* (pp. 463–496). Paris: Presses Universitaires de France.
- Harley, Marjorie. (1961). Some observations on the relationship between genitality and structural development at adolescence. *Journal of the American Psychoanalytic Association*, 9, 434–460.
- Harley, Marjorie, and Weil, Annemarie. (1990). Phyllis Greenacre, M.D. (1894–1989). *International Journal of Psychoanalysis*, 71, 523–525.
- Harlow, Harry. (1958). La nature de l'amour. *Le psychologue américain*, 13, 673–685.
- Harmat, Pál. (1988). *Freud, Ferenczi und die Psychoanalyse in Ungarn*. Tübingen: Diskord.
- Harmatta János, Szónyi, Gábor. (1992). Hungary. In P. Kutter (Ed.), *Psychoanalysis International, A Guide to Psychoanalysis throughout the World*, (Vol. 1, Europe, p. 173–184). Stuttgart-Bad Cannstatt: Frommann-Holzboog.
- Harnik, Jenő. (1927). Psychoanalytischer Film. *Internationale Zeitschrift für Psychoanalyse*, 13, 580–581.
- Harris, Adrienne, and Aron, Lewis. (1997). Ferenczi's semiotic theory: previews of postmodernism. *Psychoanalytic Inquiry*, 17, 522–534.
- Harris, Adrienne. (1995). Introduction: symposium on psychoanalysis and linguistics. *Psychoanalytic Dialogues*, 5, 615–618.
- Harris, Martha. (1983). Esther Bick, 1901–1983. *Journal of Child Psychotherapy*, 9, 101–102.
- Harris, Martha, and Bick, Esther. (1987). *Collected papers of Martha Harris and Esther Bick*. Perthshire, U.K.: Clunie Press for Roland Harris Education Trust.
- Hartenberg, Paul. (1902). *La névrose d'angoisse*. Paris: Félix Alcan.
- Hartmann, Eduard von. (1931). *Philosophy of the unconscious. speculative results according to the inductive method of physical science* (W. C. Coupland, Trans.). London: Routledge. (Original work published 1869)
- Hartmann, Heinz. (1927). *Die Grundlagen der Psychoanalyse*. Leipzig: G. Thieme.
- . (1944). The psychiatric work of Paul Schilder. *Psychoanalytic Review*, 31, 1, 296.
- . (1950). Comments on the psychoanalytic theory of the ego. *Psychoanalytic Study of the Child*, 5, 74–96.
- . (1956). The ego concept in Freud's work. *International Journal of Psychoanalysis*, 37, 425–438.
- . (1958). *Ego psychology and the problem of adaptation* (David Rapaport, Trans.). New York: International Universities Press. (Original work published 1938)
- . (1964). *Essays on ego psychology*. New York: International Universities Press. (Original work published 1939.)
- Hartmann, Heinz, and Loewenstein, Rudolph. (1962). Notes on the superego. *Psychoanalytic Study of the Child*, 17, 42–81.
- Hartmann, Heinz, and Milch, W. (2000). Efficacy treatment of suicidal patients: transference and countertransference. *Progress in Self Psychology*, 16, 87–102.
- Hartmann, Heinz, Kris, Ernst, and Loewenstein, Rudolph M. (1946). Comments on the formation of psychic structure. *Psychoanalytic Study of the Child*, 2, p. 11–38.
- . (1964). *Papers on psychoanalytic psychology*. New York: International Universities Press.
- Hartmann, Lawrence. (1994). Heinz Hartmann: A memorial tribute and filial memoir. *Psychoanalytic Study of the Child*, 49, 3–11.
- Hartnack, Christiane. (1990). Vishnu on Freud's desk: psychoanalysis in colonial India. *Social Research*, 57 (4), p. 921–949.
- Hartocollis, Peter. (2002). "Actual neurosis" and psychosomatic medicine. *International Journal of Psychoanalysis*, 83, 1361–1374.
- Hartocollis, Peter, and Graham, I. (Eds.). (1991). *The Personal Myth in Psychoanalytic Theory*. Madison, CT: International Universities Press.
- Hauser, Stuart T. and Smith, Henry F. (1991). The development and experience of affect in adolescence. *Journal of the American Psychoanalytic Association*, 39(S), 131–168.
- Häutler, Adolf. (1962–75). Scientific meeting, March 20, 1907: Mysticism and the comprehension of nature. In Herman Nunberg and Ernst Federn (Eds.), *Minutes of the Vienna Psychoanalytic Society* (M. Nunberg, Trans.). (Vol. 2, 1906–08). New York: International Universities Press [1962–75]
- Hayley, Thomas T. S. (1991). Thomas Forrest Main, 1911–1990. *International Journal of Psychoanalysis*, 72, 719–722.

- Hayman, Anne. (1986). What do we mean by phantasy? *International Journal of Psychoanalysis*, 70, 105–114.
- Haynal, André. (1988). *The technique at issue: Controversies in psychoanalysis from Freud and Ferenczi to Michael Bálint*. (Elizabeth Holder, Trans.). London: Karnac. (Original work published 1986)
- Hazan, Marie. (1994). Transmission, filiation et institution psychanalytique. Rencontre avec François Peraldi. *Filigrane*, 3, 135–161.
- Hécaen, H. and Lantéri-Laura, Georges. (1977). *Évolution des connaissances et des doctrines sur les localisations cérébrales*. Paris: Desclée de Brouwer.
- . (1989). *Les fonctions du cerveau*. Paris: Masson.
- Hegel, Georg Wilhelm Friedrich. (1931). *The phenomenology of mind* (J. B. Baillie, Trans.). London: G. Allen and Unwin. (Original work published 1807.)
- Heigl, Franz, and Axel, Triebel. (1977). *Lernvorgänge in psychoanalytischer therapie*. Bern: Hans Huber.
- Heimann, Paula. (1942). Sublimation and its relation to processes of internalization. *International Journal of Psychoanalysis*, 23, 8–17.
- . (1950). On countertransference. *International Journal of Psychoanalysis*, 31, 81–84.
- . (1952). Certain functions of introjection and projection in early infancy. In Klein, Heimann, Isaacs, and Riviere (Eds.). *Developments in Psycho-Analysis* (p. 122–168). London, Hogarth.
- . (1962). Contribution to the discussion of “The curative factors in psycho-analysis.” *International Journal of Psychoanalysis*, 43, 228–231.
- . (1989). *About children and children-no-longer. Collected papers of Paula Heimann 1942–1980*. M. Tonnesmann, London/New York: Tavistock Publications/Routledge.
- Held, René. (1964–1965). Rapport clinique sur les psychothérapies d’inspiration psychanalytique freudienne. *Revue française de psychanalyse*, 28 (special number).
- . (1968). *De la psychanalyse à la médecine psychosomatique*. Paris: Payot.
- . (1968). *Psychothérapie et psychanalyse*. Paris: Payot.
- . (1973). *L’Œil du psychanalyste*. Paris: Payot.
- Hell, Victor. (1974). *Friedrich von Schiller: théories esthétiques et structures dramatiques*. Paris: Aubier.
- Heller, Peter. (1990). *A child analysis with Anna Freud..* Madison, CT: International Universities Press.
- . (1992). *Anna Freud’s letters to Eva Rosenfeld*. Madison, CT: International Universities Press.
- Hellman, Ilse. (1990). *From war babies to grandmothers; Forty-eight years in psychoanalysis*. London: Karnac.
- Hemecker, Wilhelm. (1991). *Vor Freud: philosophische geschichtliche voraussetzungen der psychoanalyse*. Munich, Germany: Philosophia.
- Henderson, A F, Gregoire, A J, Kumar, RD, Studd, JW. (1991). Treatment of severe postnatal depression with oestradiol skin patches. *Lancet*, 338, 816–17.
- Henderson, Joseph L. (1985). The self in review. *Journal of Analytical Psychology*, London, 30, p. 243–246.
- . (1995). Reflections on the history and practice of Jungian analysis. In Murray Stein (Ed.): *Jungian analysis*. La Salle, IL: Open Court.
- Henry, Michel. (1985). *Généalogie de la psychanalyse: Le commencement perdu*. Paris: Presses Universitaires de France.
- . (1993). *The genealogy of psychoanalysis* (Douglas Brick, Trans.). Stanford, CA: Stanford University Press. (Original work published 1985)
- Hermann, Imre. (1933). *A pszichoanalízis, mint módszer*. Budapest: Novák R. és Tsa.
- . (1943). *Az ember ösi ösztönei*. Budapest: Magvető.
- . (1945). *Az antiszemitizmus lélektana*. (The psychosis of anti-Semitism), Budapest: Bibliotheca.
- . (1972). *L’instinct filial*. (G. Kassai, Trans.). Paris: Denoël.
- . (1976). Clinging-searching: Contrasting instincts, rel. sadism, masochism,” *Psychoanalytic Quarterly*, 45:5–36.
- . (1978). *Psychanalyse et logique*. Paris: Denoël.
- . (1982). La honte comme angoisse sociale. *Confrontation*, 8, 167–177. (Original work published 1929)
- Hermanns, Ludger M. (1982). John F. Rittmeister und C. G. Jung. *Psyche*, 36, 1022–1031.
- . (1994). Karl Abraham und die Anfänge der Berliner psychoanalytischen Vereinigung. *Luzifer-Amor*, 13, 30–40.
- Hernández, Max. (1992). *Memoria del bien perdido. Identidad, conflicto y nostalgia en el Inca Garcilaso de la Vega*. Lima: Instituto de estudios peruanos y biblioteca peruana de psicoanálisis.
- Hernández, Max, et al. (1996). *Entre el mito y la historia*. 3d. ed. Lima: Fondo Sidea. (Original work published 1987)

- Hesnard, Angélo. (1960). *L'Œuvre de Freud et son importance pour le monde moderne*. Preface by M. Merleau-Ponty, Paris: Payot.
- Hesnard-Félix, Edith. (1984). Le Dr. Hesnard et la naissance de la psychanalyse en France. Doctoral thesis, University of Paris I.
- Heuyer, Georges. (1924). La psychanalyse. In É. Sargent (Ed.), *Traité de pathologie médicale* (Vol. 1, Psychiatrie, p. 35–79). Paris: Maloine.
- . (1936). Préface. In Sophie Morgenstern, *Psychanalyse infantile*. Paris: Denoël.
- Heuyer, Georges, and Morgenstern, Sophie. (1927). Un cas de mutisme chez l'enfant. Guérison par la psychanalyse. *Journal de la Société de psychiatrie*, 19, 6.
- Hidas, György. (1987). Die Psychoanalyse und ihre Schicksale in Ungarn. *Sigmund Freud House Bulletin*, 11 (2), 1–12.
- Hilferding-Hönigsberg, Margarethe. (1919). Der Schleichhandel. *Kampf*, 12, p. 300–304.
- . (1920). Was kostet die auskömmliche Ernährung? *Kampf*, 13, p. 101–105.
- . (1926). *Geburtenregelung. Erörterungen zum 144. Nachw. A. Adler*. Vienna-Leipzig: Moritz Perles.
- Hill, John. (1975). Individuation and the association experiment. *Annual of Archetypal Psychology*, 145–151.
- Hillman, James. (1971). *The Feeling Function, in Lectures on Jung's Typology*. Zürich: Spring.
- Hinshelwood, Robert D. (1991). Psychodynamic psychiatry before World War I. In Berrios and Freeman, (Eds.), *150 years of British psychiatry*. London: Gaskell.
- . (1994). *Clinical Klein: from theory to practice*. New York: Basic Books.
- . (1997). The elusive concept of “internal objects”. (1934–43). *International Journal of Psychoanalysis*, 78, 877–898.
- Hirschmüller, Albrecht. (1978). *Physiologie und Psychoanalyse in Leben und Werk Josef Breuers*. Bern-Stuttgart: Hans Huber.
- . (1989). *The life and work of Josef Breuer*. New York: New York University Press.
- . (1989). Freuds “Mathilde,” Ein weiterer Tagesrest zum Irma-Traum. *Jahrbuch für Psychoanalyse*, 24, 128–159.
- . (1991). *Freuds begegnung mit der psychiatrie*. Tübingen, Germany: Diskord.
- Hirt, Jean-Michel. (1993). *Le miroir du prophète: Psychanalyse et Islam*. Paris: Grasset.
- Hitschmann, Eduard. (1911). *Freud's theories of the neuroses, by Dr. Eduard Hitschmann*. Authorized translation by Dr. C.R. Payne, with an introduction by Ernest Jones. New York, Moffat, Yard and company, 1917. 257 p.
- . (1932). A ten years report of the Vienna Psycho-Analytical Clinic. *International Journal of Psychoanalysis*, 245–255.
- . (1956). *Great men: Psychoanalytic studies*. New York: International Universities Press.
- Hitschmann, Eduard, and Bergler, Edmund. (1936). *Frigidity in women*. Washington, New York: Nervous and mental disease publishing company.
- Hobman, Joseph Burton (Ed.). (1945). *David Eder: memoirs of a modern pioneer*. London: Victor Gollancz.
- Hochsinger, Carl. (1938). *Die Geschichte des ersten öffentlichen Kinder-Kranken-Institutes in Wien während seines 150jährigen Bestandes 1788–1938*. Vienna: Verlag des Kinder-Kranken-Institutes.
- Höck, Kurt. (1988). *Entwicklung der Balint-Gruppenarbeit in der D.D.R. Klinik und Praxis*. Berlin: Springer.
- Hoffer, Axel. (1985). Toward a definition of psychoanalytic neutrality. *Journal of the American Psychoanalytic Association*, 33, 771–795.
- Hoffer, Peter T. (1992). The concept of phylogenetic inheritance in Freud and Jung. *Journal of the American Psychoanalytic Association*, 40, 517–530.
- Hoffer, Willi. (1947). Diaries of adolescent schizophrenics (hebephrenics). *Psychoanalytic Study of the Child*, 2, 293–312.
- . (1950). Mouth, hand and ego integration. *Psychoanalytic Study of the Child*, 3–4, 49–56.
- . (1955). *Psychoanalysis: Practical and research aspects*. Baltimore: Williams & Wilkins.
- . (1956). Transference and transference neurosis. *International Journal of Psychoanalysis*, 37, 377–379.
- . (1968). Notes on the theory of defense. *Psychoanalytic Study of the Child*, 23, 178–188.
- Hoffman, Edward. (1994). *The drive for self: Alfred Adler and the founding of individual psychology*. Reading, MA: Addison-Wesley.
- Hoffman, Leon, rep. (1998). Panel: The clinical value of the superego concept. *Journal of the American Psychoanalytic Association*, 46, 885–896.
- Hoffmann, Christian. (1995). Le manifeste positiviste signé par S. Freud en 1911. *Cliniques Méditerranéennes*, 45–46, 7–11.
- Holden, Jeni, Sagovsky R, and Cox, John L. (1989). Counselling in a General Practice Setting: A controlled study of health visitor intervention in treatment of

- postnatal depression. *British Medical Journal*, 298, 223–226.
- Holland, Norman N. (1966). *Psychoanalysis and Shakespeare*. New York and London: McGraw-Hill Book Company.
- . (1969). Freud and H. D. *International Journal of Psychoanalysis*, 50, 309–315. Reprinted in *Freud as we knew him*. (pp. 449–462). (Hendrik M. Ruitenbeek, Ed. [1973]). Detroit: Wayne State University Press.
- . (1999). Cognitive linguistics. *International Journal of Psychoanalysis*, 80, 357–364.
- Hollós, István. (1914). Egy versmondo betegöl. *Nyugat*, 8, p. 333–340.
- . (1919). Die Phasen des Selbstbewusstseinsaktes. *Internationale Zeitschrift für Psychoanalyse*, 5, p. 93–101.
- . (1927). Mes adieux à la Maison jaune. *Le Coq-Héron*, 100, 1986.
- . (1933). Psychopathologie alltäglicher telepathischer Erscheinungen. *Imago*, 19, 529–546.
- Holmes, Jeremy. (1993). *John Bowlby and attachment theory*. London: Routledge.
- Holroyd, Michael. (1973). *Lytton Strachey: a critical biography*. London: Heinemann.
- Holt, Robert R. (1975). The past and future of ego psychology. *Psychoanalytic Quarterly*, 44, 550–576.
- . (1976). Drive or wish? A Reconsideration of the psychoanalytic theory of motivation. *Psychological Issues*, 36, 158–197.
- . (1997). *Psychoanalysis and the philosophy of science*. Madison, CT: International Universities Press.
- Holt, Robert R. (Ed.). (1997). *Psychoanalysis and the philosophy of science. Collected papers of Benjamin Rubenstein*. Madison, CT: International Universities Press.
- Holzman, Philip, and Aronson, Gerald, (1992). Psychoanalysis and its neighboring sciences: Paradigms and opportunities, *Journal of the American Psychoanalytical Association*, 40 (1), 63–88.
- Hook, R. (Ed.). (1979). *Fantasy and symbol; studies in anthropological interpretation, essay in honor of George Devereux*. London: Academic Press.
- Horkheimer, Max, and Adorno, Theodor. (1972). *Dialectic of enlightenment* (John Cumming, Trans.). New York: Continuum.
- Horney, Karen. (1922). *Feminine psychology*. New York, W.W. Norton.
- . (1922). On the genesis of the castration complex in women. In H. Kelman (Ed.). *Feminine Psychology*. New York: W. W. Norton, 1967.
- . (1924). On the genesis of the castration complex in women. *International Journal of Psychoanalysis*, 5, 50–65.
- . (1935). The problem of feminine masochism. *Psychoanalytic Review*, 22, 241–257.
- . (1937). *The neurotic personality of our time*. New York: W. W. Norton.
- . (1939). *New ways in psychoanalysis*. New York: W. W. Norton.
- . (1942). *Self-analysis*. New York: W. W. Norton.
- . (1950). *Neurosis and human growth: The struggle toward self-realization*. New York: W. W. Norton.
- . (1967). *Feminine psychology*. New York: W.W. Norton. (Original work published 1922)
- Horney, Karen (Ed.). (1946). *Are you considering psychoanalysis?* New York: W. W. Norton.
- Houssier, Florian. (2003). G. S. Hall (1844–1924): un pionnier dans la découverte de l'adolescence. Ses liens avec les premiers pschanalystes de l'adolescent. *Psychiatrie de l'enfant*, 46, 655–668.
- Houzel, Didier. (1980). Rêve et psychopathologie de l'enfant. *Neuropsychiatrie de l'enfance et de l'adolescence*, 28 155–164.
- Houzel, Didier, and Catoire, Gilles. (1986). La psychanalyse des enfants. *Encyclopédie médico-chirurgicale, Psychiatrie*. Paris: Encyclopédie médicale-chirurgicale. Fasc. 37-812-A-10.
- Huber, Wolfgang. (1977). *Psychoanalyse in Österreich seit 1933*. Vienna-Salzburg: Geyer.
- Hug-Hellmuth, Hermine von. (1911–1924). *Essais psychanalytiques*. D. Soubrenie ed. Paris: Payot, 1991.
- . (1919). *A study of the mental life of the child*. New York and Washington; Nervous and Mental Disease Monograph series.
- . (1919). *Tagebuch eines halbwüchsigen Mädchen; von 11 bis 14 1/2 Jahren*. Vienna: Internationaler Psychoanalytischer Verlag.
- . (1921). On the technique of child analysis. *International Journal of Psychoanalysis*, 2, p. 287–305.
- . (1971). *A Young Girl's Diary*. Boston: Milford House. (Original work published 1924)
- Hulak, Fabienne, and Bonnet, Marguerite. (1992). *Folie et psychanalyse dans l'expérience surréaliste*. Nice: Z'Éditions.
- Humbert, Élie Georges. (1983). *Jung*. Paris: Éditions Universitaires.

- . (1988). *C. G. Jung: the fundamentals of theory and practice*. (Ronald G. Jalbert, Trans.). Wilmette, IL: Chiron. (Original work published 1983)
- Hungarian Psychoanalytic Association. (1933). *Lélekelemzési Tanulmányok* (Psychoanalytic Studies). Budapest: Somló.
- Hunter, Doris. (1979). Helen Ross 1890–1978. *The Psychoanalytic Quarterly*, XLVIII, 465–469.
- Hurvich, Marvin. (1989). Traumatic moment, basic dangers, and annihilation anxiety. *Psychoanalytic Psychology*, 6, 309–323.
- Hurwitz, Emmanuel. (1979). *Otto Gross: Paradies-Sucher zwischen Freud und Jung*. Zürich.
- Huss, Magnus. (1849). *Alcoholismus chronicus eller kronisk alkoholsjukdom*. Stockholm: n.p.
- Husserl, Edmund. (1931). *Ideas: general introduction to pure phenomenology* (W. R. Boyce Gibson, Trans.). London: G. Allen and Unwin.
- Hyppolite, Jean. (1971). *Figures de la pensée philosophique; écrits de Jean Hyppolite (1931-1968)*. Paris: Presses Universitaires de France.
- . (1988). A spoken commentary on Freud's *Verneinung*. In *The seminar of Jacques Lacan*. Book 1: *Freud's papers on technique, 1953–1954* (John Forrester, Trans.). New York: W. W. Norton. (Original work published 1954)
- Igoïn, Laurence. (1979). *La boulimie et son infortune*. Paris: Presses Universitaires de France.
- Ihanus, Juhani. (1994). *Vietit vai Henki*. Helsinki, Finland: Yliopistopaino.
- Inderbitzin, Lawrence, and Levy, Steven. (1998). Repetition compulsion revisited: Implications for technique. *Psychoanalytic Quarterly*, 67, 32–53.
- . (2000). Regression and psychoanalytic technique: a concept's concretization. *Psychoanalytic Quarterly*, 69, 195–224.
- Innes, Smith J. (1990). La neutralité de l'analyste. *Revue belge de psychanalyse*, 17, 43–58.
- Irigaray, Luce. (1985). *Speculum of the other woman* (G. C. Gill, Trans.). Ithaca, NY: Cornell University Press. (Original work published 1974)
- Isaacs, Susan. (1930). *Intellectual growth in young children*. London: Routledge.
- . (1933). *Social development in young children*. London: Routledge.
- . (1940). Temper tantrums in early childhood and their relation to internal objects. *International Journal of Psychoanalysis*, 21, 280–293. Republished in S. Isaacs (1948), *Childhood and after*. London: Routledge.
- . (1948). On the nature and function of phantasy. *International Journal of Psychoanalysis*, 29, 73–97.
- Isakower, Otto. (1938). A contribution to the psychopathology of phenomena associated with falling asleep. *International Journal of Psychoanalysis*, 19, 331–345. (Original work published 1936)
- Isay, Richard A. (1986). The development of sexual identity in homosexual men. *Psychoanalytic Study of the Child*, 41.
- Isay, Richard A., rep. (1980). Panel: Adult masturbation: Clinical perspectives. *Journal of the American Psychoanalytic Association*, 28, 637–652.
- Israëls, Han. (1989). *Schreber: Father and son*. Madison, CT: International Universities Press. (Original work published 1981)
- Jaccard, Roland. (1992). La disparition de René Held: la psychanalyse et l'humour. *Le Monde*, Tuesday, February 25, 1992.
- Jacobs, Theodore J. (1987). Analytic secrets and the transference neurosis. *Psychoanalytical Inquiry*, 7, 485–510.
- . (1991). *The use of the self: Countertransference and communication in the analytic situation*. Madison, CT: International Universities Press.
- . (1999). Countertransference past and present: A review of the concept. *International Journal of Psychoanalysis*, 80, 575–594.
- . (2002). Secondary revision: Rethinking the analytic process and technique. *Psychoanalytic Inquiry*, 22, 3–28.
- Jacobs, Theodore J., and Rothstein, Arnold. (Eds.), (1990). *On beginning an analysis*. Madison, CT: International Universities Press.
- Jacobson, Edith. (1954). Contribution to the metapsychology of psychotic identifications. *Journal of the American Psychoanalytic Association*, 2, 239–262.
- . (1954). The self and the object world: vicissitudes of their infantile cathexes and their influence on ideational and affective development. *Psychoanalytic Study of the Child*, 9, 75–127.
- . (1964). *The self and the object world*. New York: International Universities Press.
- . (1971). *Depression: Comparative studies of normal, neurotic and psychotic conditions*. New York: International Universities Press.
- . (1976). Female superego formation and female castration conflict. *Psychoanalytic Quarterly*, 45, 525–538.
- Jacoby, Mario. (1904–1906). Experimental researches. *Coll. Works*, Vol. II. London: Routledge & Kegan Paul.



- . (1921). Psychological types. *Coll. Works*, Vol. VI. London: Routledge & Kegan Paul.
- . (1990). *Individuation and Narcissism: The Psychology of the Self in Jung and Kohut* ( Myron Gubitz, Trans.). London and New York: Routledge. (Original work published 1985)
- Jacoby, Russell. (1983). *The repression of psychoanalysis: Otto Fenichel and the political Freudians*. New York: Basic Books.
- Jaffe, Ruth. (1966). Moshe Woolf: Pioneering in Russia and Israel. In Franz Alexander, Samuel Eisenstein, and Martin Grotjahn (Eds.), *Psychoanalytic pioneers*. New York: Basic Books.
- Jakobson, Roman. (1963). *Essais de linguistique générale*. Paris: Minuit.
- Jakobson, Roman, and Halle, Morris. (1956). *Foundamentals of language* (4th ed.). The Hague, New York: Mouton.
- Janet, Pierre. (1889). *L'Automatisme psychologique: essai de psychologie expérimentale sur les formes inférieures de la vie mentale* (thesis). Paris: Felix Alcan.
- . (1903). *Les Obsessions et la psychasthénie*. Paris: Alcan.
- . (1909). *Les névroses*. Paris: Flammarion.
- . (1914, March–April). La psycho-analyse. *Journal de psychologie normale et pathologique*, 11 (1–3), 98–130.
- . (1926). *De l'angoisse à l'extase. Étude sur les croyances et les sentiments*. Paris: Félix Alcan.
- . (1937). Les troubles de la personnalité sociale. *Annales médico-psychologiques*.
- Jankélévitch, Samuel. (1906). *Nature et société*. Paris: Félix Alcan.
- . (1947). *Révolution et tradition*. Paris: J.-B. Janin.
- Jaques, Elliott. (1965). Death and the mid-life crisis. *International Journal of Psychoanalysis*, 46, 502–514.
- Jaspers, Karl. (1913). *Allgemeine psychopathologie*. Berlin: Springer.
- . (1963). *General psychopathology* Manchester, UK: Universities Press. (Original work published 1913)
- Jeammet, Nicole. (1989). *La Haine nécessaire*. Paris: Presses Universitaires de France.
- Jeammet, Phillippe. (1989). Psychopathologie des troubles des conduites alimentaires à l'adolescence. *Confrontations psychiatriques*, 31, 177–202.
- . (1991). Dysrégulations narcissiques et objectives dans la boulimie. In: Bernard Brusset and Catherine Couvreur (Eds.). *La boulimie* (pp. 89–104). Paris: Presses Universitaires de France.
- . (1994). Adolescence et processus de changement. In Daniel Widlöcher (Ed.), *Traité de psychopathologie* (pp. 687–726). Paris: Presses Universitaires de France.
- Jeammet, Philippe, and Birot, Elisabeth (Eds.). (1994). *Étude psychopathologique des tentatives de suicide chez l'adolescent et le jeune adulte*. Paris: Presses Universitaires de France.
- Jeammet, Philippe, and Kestemberg, Evelyne. (1987). *Le psychodrame psychanalytique*. Paris: Presses Universitaires de France.
- Jeanneau, Augustin. (1985). L'hystérie, unité et diversité. *Revue française de psychanalyse*, 49 (1), 258–283.
- . (1990). L'hypocondrie, ou La mentalisation de l'impossible. *Cahiers du Centre pour la psychanalyse et la psychothérapie*, 21, 83–99.
- Jekels, Ludwig. (1909). Leczenie psychoneuroz za pomoca metody psychoanalitycznej Freuda, tudziej kazuistyka. *Med. Kron Lek*, Warsaw.
- . (1913). Einige Bemerkungen zur Trieblehre. *Internationale Zeitschrift für Psychoanalyse*, 1, 439–443.
- . (1914). Der Wendepunkt im Leben Napoleons I. *Imago*, 3, 313–381.
- . (1936). Die psychoanalytische Therapie. *Svenska Laekartidn*, 33, 1797–1802, 1821–1831.
- . (1952). *Selected papers*. London: Imago Publishing Co.
- Jelliffe, Smith Ely. (1922). Psychopathology and organic disease, *Archives of Neurology and Psychiatry*, 8, 639–651.
- . (1939). *Sketches in psychosomatic medicine*. Washington and New York: Nervous and Mental Disease.
- Jenneau, Augustin. (1990). *Les délires non psychotiques*. Paris: Presses Universitaires de France.
- Jennings, Jerry. (1986). The revival of “Dora”: advances in psychoanalytic theory and technique. *Journal of the American Psychoanalytic Association*, 34, 607–634.
- Joffe, Walter. (1969). A critical review of the envy concept. *International Journal of Psychoanalysis*, 50, 533–545.
- Johansson, Per Magnus. (1999). *Freuds psykoanalys, utgångspunkter/arvtagare i Sverige*. Göteborg: Daidalos.
- . (2003). *Freuds psykoanalys, arvtagare i Sverige*. Göteborg: Daidalos.

- Jones, Ernest. (1908). Rationalization in everyday life. *Journal of Abnormal Psychology*.
- Jones, Ernest. (1910). *On the nightmare*. London: Hogarth Press and the Institute of Psycho-Analysis, 1931.
- . (1913). Pathology of morbid anxiety. *Papers on Psychoanalysis*. London: Bailliere, Tindall & Cox, 1918.
- . (1927). James Glover, 1882–1926. *International Journal of Psychoanalysis*, 8, 1–9.
- . (1936). Review of the “Dictionary of psychology.” (Howard C. Warren, Ed.). London: Allen and Unwin. *International Journal of Psychoanalysis*, 17, 247–248.
- . (1948). Anal-erotic character traits. In *Papers on psycho-analysis* (5th ed.). Boston: Beacon Press. (Original work published 1918)
- . (1948). The theory of symbolism. *Papers on Psychoanalysis*. Boston: Beacon Press. (Original work published 1916.)
- . (1948). Early development of female sexuality. In his *Papers on psycho-analysis* (5th ed.). London: Baillière, Tindall, and Cox. (Original work published 1927.)
- . (1949). *Hamlet and Oedipus*. London: Hogarth Press.
- . (1949). *On the nightmare*. London: Hogarth Press and the Institute of Psycho-Analysis.
- . (1953–1957). *Life and work of Sigmund Freud*. New York: Basic Books.
- . (1957). Lay analysis. In his *Life and work of Sigmund Freud*. Vol. 3: *The Last Phase, 1919–1939*. New York: Basic Books.
- . (1959). *Free associations. Memories of a psycho-analyst*. London, New York: Basic Books.
- . (1964). *Essays in applied psycho-analysis*. New York: International Universities Press.
- Jones, Ernest (Ed.). (1924). *Glossary of psychoanalytical terms*.
- Jordán-Moore, Juan-Francisco. (1995). Ignacio Matte-Blanco. *International Journal of Psychoanalysis*, 76, 1035–1041.
- Joseph, E.D. (1987). Psychiatry and psychoanalysis in the People’s Republic of China: a transcultural view. In R. Fine (Ed). *Psychoanalysis around the world*. New York: Howarth Press.
- Jouve, Pierre Jean. (1933). *Sueur de sang*. Paris: Cahiers libres.
- . (1973). *Paulina 1880* (Rosette Letellier and Robert Bullen, Trans.). Indianapolis: Bobbs-Merrill. (Original work published 1925.)
- . (1997). *Hecate* (Lydia Davis, Trans.). Evanston, IL: Marlboro press/Northwestern. (Original work published 1928.)
- . (1997). *Vagadu* (Lydia Davis, Trans.). Evanston, IL: Marlboro Press. (Original work published 1931.)
- Juillerat, Bernard. (1991). *Céipe chasseur: Une mythologie du sujet en Nouvelle-Guinée*. Paris: Presses Universitaires de France.
- Julien, Philippe. (1990). *Pour lire Jacques Lacan*. Paris: Seuil.
- . (1991). *Le Manteau de Noé: essais sur la paternité*. Paris: Desclée de Brouwer.
- Jung, Emma. (1957). *Animus and anima*. New York: Analytical Psychology Club of New York.
- Jung, Emma, and Franz, Marie Louise von. (1971). *The Grail Legend*. (Andrea Dykes, Trans.). London: Hodder & Stoughton.
- Juranville, Alain. (1984). *Lacan et la philosophie*. Paris: Presses Universitaires de France.
- Jurgenson, Geneviève. (1973). *La Folie des autres*. Paris: Robert Laffont.
- Jury, Paul. (1950). Descartes, psychanalyste avant la lettre, *Psyché*, 40. (Original work published 1935)
- . (1956). *Journal d’un prêtre*. Paris: Gallimard.
- . (1964). *Les débuts de l’évangile ou les quatre légendes de Jean-Baptiste*. Gentilly: Albin Michel.
- Kaës, René. (1976). *L’Appareil psychique groupal: constructions du groupe*. Paris: Dunod.
- . (1988). Le pacte dénégatif dans les ensembles transsubjectifs. In A. Missenard (Trans.), *Le Négatif. Figures et modalités* (pp. 101–136). Paris: Dunod.
- . (1993). “Introduction au concept de la transmission psychique dans la pensée de Freud,” in R. Kaës et al., *Transmission de la vie psychique entre générations*, Paris: Dunod.
- . (1993). *Le groupe et le sujet du groupe*. Paris: Dunod.
- . (1994). *Les voies de la psyché, hommage à Didier Anzieu*. Paris: Dunod.
- Kaës, René, and Anzieu, Didier. (1976). *Chronique d’un groupe, le groupe du ‘Paradis perdu’: observation et commentaries*. Paris: Dunod.
- Kaës, René, Faimberg, Haydée, Enriquez, Micheline, et al. (1993). *Transmission de la vie psychique entre générations*. Paris: Dunod.

- Kabcenell, Robert. (1970). Eulogy for Elisabeth Geleerd. Unpublished. A.A. Brill Library, the New York Psychoanalytic Institute.
- Kacirek, Suzanne. (1980). Le concept de libido selon C. G. Jung: des "Métamorphoses et symboles de la libido" à "L'énergétique psychique." *Cahiers jungiens de psychanalyse*, 26, 1–20.
- Kakar, Sudhir. (1996). *Culture and psyche: Psychoanalysis and India*. New York: Psyche Press.
- Kamieniak, Jean-Pierre. (1998). *Freud, un enfant de l'humour*. Lausanne-Paris: Delachaux & Niestlé.
- Kamieniecki, Hannah. (1994). *Histoire de la psychosomatique*. Paris: Presses Universitaires de France.
- Kanner, Leo. (1943). Autistic disturbances of affective contact. *Nervous Child*, 2, 217–250.
- . (1973). *Childhood psychosis, initial studies and new insights*. Washington, DC: Winston.
- Kantrowitz, Judith. (1999). The role of the preconscious in psychoanalysis. *Journal of the American Psychoanalytic Association*, 47, 65–90.
- Kanzer, Mark. (1969). Sigmund and Alexander Freud on the Acropolis. *American Imago*, 26, 324–54.
- . (1972). Victor Tausk—The creativity and suicide of a psychoanalyst. *Psychoanalytic Quarterly*, 41, 556–584.
- . (1985). Identification and its vicissitudes. *International Journal of Psychoanalysis*, 66, 1, 19–30.
- Kanzer, Mark (Ed.). (1971). *The unconscious today*. New York: International Universities Press.
- Kanzer, Mark, and Glenn, Jules (Eds.). (1980). *Freud and his patients*. New York: Jason Aronson.
- Kaplan, Abraham. (1977). Spinoza and Freud. *Journal of the American Academy of Psychoanalysis*, 5, 299–326.
- Kaplan, Donald B. (1984). Some conceptual and technical aspects of the actual neurosis. *International Journal of Psychoanalysis*, 65, 295–306.
- Kaplan, Donald M. (1984). Helene Deutsch's 'hysterical fate neurosis' revisited. *Psychoanalytic Quarterly*, 53, 240–266.
- Kapsambelis, Vassilis. (1997). *Termes psychiatriques français d'origine grecque*. Paris: Masson.
- Kardiner, Abram. (1939). *The individual and his society*. New York: Columbia University Press.
- . (1941). *The traumatic neuroses of war*. New York: Paul B. Hoeber.
- . (1945). *The psychological frontiers of society*. New York: Columbia University Press.
- . (1961). Psychoanalysis and anthropology. *Science and Psychoanalysis*, 4, 21–27.
- . (1977). *My analysis with Freud. Reminiscences*. New York: W. W. Norton.
- Kardiner, Abram, and Ovesey, Lionel. (1951). *The mark of oppression*. New York: W.W. Norton.
- Kardiner, Abram, and Spiegel, Herbert. (1947). *War, stress and neurotic illness*. New York: Paul Hoeber.
- Kardiner, Abram, Ovesey, Lionel, and Karush, Aaron. (1959). A methodological study of Freudian theory I-IV. In *Journal of Nervous and Mental Diseases*, 129 (1), 11–19; 129 (2), 133–143; 129 (3), 207–221; 129 (4), 341–156.
- Kast, Verena. (1992). *The dynamics of symbols: fundamentals of Jungian psychotherapy* (Susan A. Schwarz, Trans.). New York: Fromm International. (Original work published 1990)
- Katan, Anny. (1951). The role of displacement in agoraphobia. *International Journal of Psychoanalysis*, 32, 1–10.
- . (1959). The nursery school as a diagnostic help to the child guidance clinic. *Psychoanalytic Study of the Child*, 14, 250–264.
- . (1961). Some thoughts about the role of verbalization in early childhood. *Psychoanalytic Study of the Child*, 16, 184–189.
- . (1972). The infant's first reaction to strangers: distress or anxiety? *International Journal of Psychoanalysis*, 53, p. 501–503.
- . (1973). Children who were raped. *Psychoanalytic Study of the Child*, 28, 208–224.
- Katan, Maurits. (1953). Schreber's prepsychotic phase. *International Journal of Psychoanalysis*, 34 (1), 43–51.
- . (1954). The importance of the non-psychotic part of the personality in schizophrenia. *International Journal of Psychoanalysis*, 35 (2), 119–128.
- Katan, Maurits. (1959). Schreber's hereafter: Its building-up (Aufbau). and its downfall. *Psychoanalytic Study of the Child*, 14, 314–382.
- . (1962). A causerie on Henry James's "The Turn of the Screw." *Psychoanalytic Study of the Child*, 17, 473–493.
- . (1964). Fetishism, splitting of the ego, and denial. *International Journal of Psychoanalysis*, 45 (2–3), 237–245.
- . (1969). The link between Freud's work on aphasia, fetishism and constructions in analysis. *International Journal of Psychoanalysis*, 50 (4), 547–553.
- Katchalov, Pavel. (1994). Historiques des méthodes psychothérapeutiques dans l'ancienne URSS. *Journal de psychiatrie*, 7102–104.

- Katz, Ned. (1995). *The invention of heterosexuality*. New York: Dutton.
- Kaufholz-Messmer, Eliane. (1975). *Karl Kraus*. Paris: Editions de l'Herne.
- Kaufmann, Pierre. (1979). *L'Inconscient du politique*. Paris: Presses Universitaires de France.
- Kavka, J. (1984). Fifty years of psychoanalysis in Chicago: A historical perspective. In G. Pollock and J. Gedo (Eds.), *Psychoanalysis: The vital issues* (Vol. II, pp. 465–93). New York: International Universities Press.
- Kemper, Werner. (1943). *Der Störungen dere Liebesfähigkeit beim Weibe*. Leipzig: Thieme.
- . (1955). *Der Traum und seine Bedeutung*. Hamburg: Rowohlt.
- . (1973). Selbstdarstellung. In L. Pongratz (Ed.), *Psychotherapie in Selbstdarstellungen*. Bern-Stuttgart: Hans Huber, pp. 259–345.
- Kennerley, H, Gath, D. (1989, Sept.). Maternity blues I. Detection and measurement by questionnaire. *British Journal of Psychotherapy*, 155, 356–62
- Kernberg, Otto F. (1970). A psychoanalytic classification of character pathology. *Journal of the American Psychoanalytic Association*, 18 (4), 800–822.
- . (1975). *Borderline conditions and pathological narcissism*. New York: Jason Aronson.
- F. (1976). Technical considerations in the treatment of borderline personality organization. *Journal of the American Psychoanalytic Association*, 30, 795–829.
- . (1980). *Internal world and external reality: object relations theory applied*. New York: Aronson.
- . (1984). *Les trouble graves de la personnalité*. Paris: Presses Universitaires de France.
- . (1989). *Narcissistic personality disorder*. Philadelphia: W.B.Saunders.
- . (1989). Impasse and interpretation by Herbert Rosenfeld. *International Journal of Psychoanalysis*, 70, 173–177.
- . (1991). Sadomasochism, sexual excitement, and perversion. *Journal of the American Psychoanalytic Association*, 39, 333–362.
- Kernberg, Otto F. (1992). *Aggression in personality disorders and perversion*. New Haven: Yale University Press.
- . (1992). Psychopathic, paranoid, and depressive transferences. *International Journal of Psychoanalysis*, 73, 13–28.
- . (1995). *Love relations. Normality and pathology*. New Haven: Yale University Press.
- . (1996). Thirty methods to destroy the creativity of psychoanalytic candidates. *International Journal of Psychoanalysis*, 77, 1031–1040.
- . (1999). Psychoanalysis, psychoanalytic psychotherapy and supportive psychotherapy. *International Journal of Psychoanalysis*, 80, 1075–1092.
- . (2001). Object relations, affects, and drives: toward a new synthesis. *Psychoanalytical Inquiry*, 21, 604–619.
- Kerr, John. (1993). *A most dangerous method: The story of Jung, Freud, and Sabina Spielrein*. New York: Alfred A. Knopf.
- Kestemberg, Evelyne. (1962). L'identité et l'identification chez les adolescents: problèmes techniques et théoriques. *Psychiatrie de l'enfant*, 5 (2): 441–552.
- . (1978). La relation fétichique à l'objet: quelques notations. *Revue française de psychanalyse*, 42 (2): 195–214.
- . (1999). *L'adolescence à vif*. Paris: Presses Universitaires de France.
- . (2001). *La psychose froide*. Paris: Presses Universitaires de France.
- Kestemberg, Evelyne, and Jeammet, Philippe. (1987). *Le psychodrame psychanalytique*. Paris: Presses Universitaires de France.
- Kestemberg, Evelyne, Kestemberg, Jean, and Decobert, Simone. (1972). *La faim et le corps: une étude psychanalytique de l'anorexie mentale*. Paris: Presses Universitaires de France.
- Kestemberg, Jean (1962). Á propos de la relation érotomaniaque, *Revue française de psychanalyse*, 26, 5, 533–587.
- Kestenbaum, G.I. (1983). Toward a definition of intellectualization. *Psychoanalysis and Contemporary Thought*, 6, 671–692.
- Khan, Masud. (1960). Clinical aspects of the schizoid personality: Affects and technique. *International Journal of Psychoanalysis*, 41, 430–437.
- . (1972). La capacité de rêver. *Nouvelle Revue de psychanalyse*, 5 283–286.
- . (1974). *The privacy of the self*. London: Hogarth Press.
- . (1979). *Alienation in perversions*. New York: International Universities Press.
- . (1983). *Hidden selves: Between theory and practice in psychoanalysis*. New York: International Universities Press.
- . (1988). *When spring comes*. London: Chatto and Windus.

- Kim, K.I. (1978). The Oedipus complex in our changing society; with special reference to Korea. *Neuropsychiatry* (Seoul), 7 (1), 97–103.
- . (1996). Traditional therapeutic issues in psychiatric practice in Korea. Paper read in a Transcultural Psychiatry symposium of the Xth World Congress of Psychiatry, August 23.
- King, Pearl H. M. (1982). Activities of British psychoanalysts during the Second World War and the influence of their interdisciplinary collaboration on the development of psychoanalysis in Great Britain. *International Review of Psycho-Analysis*, 16, 15–33.
- . (1989). British analysts during World War II. inter-disciplinary collaboration. *International Review of Psychoanalysis*, 16, 15–34.
- King, Pearl H. M., and Riccardo Steiner. (1991). *The Freud-Klein controversies 1941–1945*. London/New York: Tavistock/Routledge.
- Kinston, W. and Cohen, J. (1986). Primal repression: clinical and theoretical aspects. *International Journal of Psychoanalysis*, 67, 337–356.
- Kirsch, Jean (1995). Transference. In M. Stein (ed.), *Jungian Analysis* (pp. 170–209). Chicago-La Salle: Open Court.
- Kirsner, Douglas. (2000). *Unfree associations*. London: Process Press.
- Kirsten Dahl, E. (1996). The concept of penis envy revisited: A child analyst listens to adult women. *Psychoanalytic Study of the Child*, 51, 303–325.
- Kleeman, James A. (1976). Freud's view on early female sexuality in the light of direct child observations. *Journal of the American Psychoanalytic Association*, 24, 3–28.
- Klein, Emanuel. (1951). Obituary Johan H.W. van Ophuijsen. *International Journal of Psychoanalysis*, 32, p. 134–135.
- Klein, Melanie. (1923). The development of a child. *International Journal of Psychoanalysis*, 4, 419–474.
- . (1926). Les principes psychologiques de l'analyse des jeunes enfants. *Essais de psychanalyse (1921–1945)*. Paris : Presses Universitaires de France.
- . (1927). Criminal tendencies in normal children. In *Love, guilt and reparation and other works 1921–1945. The writings of Melanie Klein* (Vol. 1, pp. 170–185). London: Hogarth,
- . (1927). Symposium on child analysis. *International Journal of Psychoanalysis*, 8, 339–370.
- . (1928). Early stages of the Oedipus conflict. *International Journal of Psychoanalysis*, 9, 167–180.
- . (1929). Infantile anxiety situations reflected in a work of art and in the creative impulse. In *The writings of Melanie Klein* (Vol.1, p. 210–218). London: Hogarth. (Reprinted from *International Journal of Psychoanalysis*, 10 (1929), 436–443.)
- . (1929). Personification in the play of children. *International Journal of Psychoanalysis*, 10, 193–204.
- . (1929). Infantile anxiety situations reflected in a work of art and in the creative impulse. *International Journal of Psychoanalysis*, 10, 436–443.
- . (1929). Personification in the play of children. *International Journal of Psychoanalysis*, 10, 171–182.
- . (1931). A contribution to the theory of intellectual inhibition. *International Journal of Psychoanalysis*, 12, 206–218.
- . (1932). *Die psychoanalyse des Kindes*. Vienna: Internationaler Psychoanalytischer Verlag.
- . (1933). The early development of conscience in the child. In *Love, guilt and reparation and other works 1921–1945. The writings of Melanie Klein* (Vol. 1, pp. 248–267). London: Hogarth.
- . (1935). A contribution to the psychogenesis of manic-depressive states. *International Journal of Psychoanalysis*, 16, 145–174; reprinted 1975 in *The Writings of Melanie Klein*. London: Hogarth. Vol. 1, 262–289.
- . (1935). A contribution to the psychogenesis of manic-depressive states. *International Journal of Psychoanalysis*, 16 (2), 145–174.
- . (1935). Mourning and its relation to manic-depressive states. *International Journal of Psychoanalysis*, 21, 125–153.
- . (1936). Weaning. In John Rickman (Ed.), *On the bringing up of children*. London: Kegan Paul.
- . (1940). Mourning and its relation to manic-depressive states. *International Journal of Psychoanalysis*, 21, 125–153.
- . (1945). The Oedipus complex in the light of early anxieties. *International Journal of Psychoanalysis*, 26, 11–33.
- . (1946). Notes on some schizoid mechanisms. *International Journal of Psychoanalysis*, 27: 99–110; reprinted 1952 in Klein; Heimann, Paula; Isaacs, Susan, and Riviere, Joan (eds.). *Developments in Psycho-Analysis*. London: Hogarth Press; 1975 in *The Writings of Melanie Klein*, III, 1946–1963. London: Hogarth Press, 1–24.
- . (1948). *Contributions to psychoanalysis. 1921–1945*. London: Hogarth Press.
- . (1948). *Contributions to psychoanalysis. (1967)*. London: Hogarth Press.

- . (1948). A contribution to the theory of anxiety and guilt. *International Journal of Psychoanalysis*, 29, 113–123.
- . (1952). *Developments in psycho-analysis* (Joan Riviere, Ed.). London: Hogarth Press.
- . (1952). Some theoretical conclusions regarding the emotional life of the infant. In *Envy and gratitude and other works, 1946–1963* (pp. 61–93). London: Hogarth, 1975.
- . (1952). The mutual influences in the development of ego and id. *Psychoanalytic Study of the Child*, 7, 51–53.
- . (1952a). On observing the behaviour of young infants. In Melanie Klein, Paula Heimann, Susan Isaacs, and Joan Rivière (Eds.). *Developments in psychoanalysis* (pp. 237–270). London: Hogarth.
- . (1955). The psycho-analytic play technique: Its history and significance. In *Envy and gratitude and other writings, 1946–1963* (The Writings of Melanie Klein, vol. 3), London: Hogarth/Institute of Psycho-Analysis.
- . (1957). *Envy and gratitude: A study of unconscious forces*. London: Hogarth Press.
- . (1957). Envy and Gratitude. In *Envy and Gratitude and Other Works, 1946–1963*. Reprinted in *The Writings of Melanie Klein, vol. 3*. London: Hogarth Press; New York: Delacorte/Seymour Lawrence, 1975.
- . (1958). On the development of mental functioning. In *Envy and gratitude and other works, 1946–1963*. (pp. 236–246). London: Hogarth, 1975.
- . (1959). On the sense of loneliness. In her *Envy and Gratitude and Other Works, 1946–1963*. New York: The Free Press.
- . (1959). Our adult world and its roots in infancy. In *Envy and Gratitude and Other Works 1946–1963*. London: Hogarth, 1975.
- . (1961). *Narrative of a child analysis. The conduct of the psychoanalysis of children as seen in the treatment of a ten-year-old boy*. New York: Basic Books.
- . (1967). *Essais de psychanalyse*. (M. Derrida, Trans.). Paris: Payot.
- . (1975). *The psycho-analysis of children*. (Alix Strachey, Trans.). London: Hogarth Press. (Original work published 1932)
- . (1975). *The Writings of Melanie Klein*. London: Hogarth.
- . (1975). *The psycho-analysis of children* (Alix Strachey, Trans.; revised by H. A. Thorner). Vol. 2 of *The writings of Melanie Klein*. London: Hogarth and the Institute of Psycho-Analysis. (Original work published 1932)
- . (1975). A contribution to the psychogenesis of manic-depressive states. In *The Writings of Melanie Klein* (Vol. I, pp. 262–289). London: Hogarth. (Reprinted from *International Journal of Psychoanalysis*, 16 (1935), 145–174.)
- . (1975). Early stages of the Oedipus conflict. In *The writings of Melanie Klein* (Vol. 1, 186–198). (Reprinted from *International Journal of Psychoanalysis*, 9 (1928), 167–180.)
- . (1975). Infantile anxiety situations reflected in a work of art and in the creative impulse. In *The Writings of Melanie Klein* (Vol. 1). London: Hogarth. (Reprinted from *International Journal of Psychoanalysis*, 10, (1929). 436–443.)
- . (1975). On the sense of loneliness. In *The writings of Melanie Klein, Vol. 4: Envy and gratitude and other works, 1946–1963*. London: Hogarth. (Original work published 1963.)
- . (1975). Personification in the play of children. In *The writings of Melanie Klein* (Vol. 1, pp. 199–209). London: Hogarth. (Reprinted from *International Journal of Psychoanalysis*, 10 (1929), 171–182.)
- . (1975). Some theoretical conclusions regarding the emotional life of infants. In *The Writings of Melanie Klein* (Vol. 3, pp. 61–93). London: Hogarth Press. (Original work published 1952)
- . (1975). The Oedipus complex in the light of early anxieties. *The writings of Melanie Klein* (Vol. 3, 1946–1963). London: Hogarth. (Reprinted from *International Journal of Psychoanalysis*, 26 (1945), 11–33.)
- . (1975). The psychological foundations of child analysis. In *The writings of Melanie Klein* (Vol. 2: *The psycho-analysis of children*; Alix Strachey, Trans.). London: Hogarth Press and the Institute of Psycho-Analysis.
- Klein, Melanie, and Riviere, Joan. (1937). *Love, hate and reparation*. London: Hogarth.
- Klein, Melanie, Heimann, Paula, and Money-Kyrle, Roger (Eds.). (1955). *New directions in psycho-analysis: The significance of infant conflict in the pattern of adult behaviour*. London: Tavistock Publications.
- Klein, Sydney. (1980). Autistic phenomena in neurotic patients. *International Journal of Psychoanalysis*, 61 (2), 395–401.
- Kleinman, Arthur. (1988). *Rethinking psychiatry: from cultural category to personal experience*. New York: Free Press.
- Kloocke, Ruth. (1995). Mosche Wulff, 1878–1871. *Luzifer-Amor*, 8 (16), 87–101.

- Kluckhohn, Clyde and Murray, Henry A. (eds.). (1948). *Personality in nature, society and culture*. New York: Knopf.
- Knapp, Bettina, and Chipman, Myra. (1964). *That was Yvette: The biography of the great disease*. New York: Holt, Rinehart & Winston, 1964).
- Knapp, Peter H. (1989). *Psychosomatic aspects of bronchial asthma*. Madison, WI: International Universities Press.
- Knight, Robert P. (1945). Training in psychotherapy and psychoanalysis. *Bulletin of the Menninger Clinic*, 9, 54–59.
- . (1961). David Rapaport 1911–1960, *Psychoanalytic Quarterly*, 30, 262–264.
- Kofman, Sarah. (1983). *Un métier impossible. Lecture de "construction en analyse"*. Paris: Galilée.
- Kohn, Max. (1991). *Mot d'esprit et Événement*. Paris: L'Harmattan.
- Kohon, Gregory. (1984). Reflections on Dora: the case of hysteria. *International Journal of Psychoanalysis*, 5, 73–84.
- Kohon, Gregory. (Ed.). (1999). *The dead mother. The work of André Green*. London, New York: Routledge.
- Kohut, Heinz. (1955). Review of *Beethoven and His Nephew*. *Psychoanalytic Quarterly*, 24, 453–455.
- . (1955). Review of *The Haunting Melody*. *Psychoanalytic Experiences in Life and Music*. *Psychoanalytic Quarterly*, 24, 134–137.
- . (1957). Death in Venice by Mann: Disintegration of artistic sublimation. *Psychoanalytic Quarterly*, 26, 206–228.
- . (1957). Observations on the psychological functions of music. *Journal of the American Psychoanalytic Association*, 5, 389–407.
- . (1957). Review of *The Arrow and the Lyre. A Study of the Role of Love in the Works of Thomas Mann*. *Psychoanalytic Quarterly*, 26, 273–275.
- . (1959). Introspection, empathy, and psychoanalysis. *Journal of the American Psychoanalytic Association*, 7, 459–483.
- . (1966). Forms and transformations of narcissism. *Journal of the American Psychoanalytic Association*, 14, 243–272.
- . (1968). The psychoanalytic treatment of narcissistic personality disorders. In *The search for the self* (Vol. 1, 477–509).
- . (1971). *The analysis of the self: A systematic approach to the psychoanalytic treatment of narcissistic personality disorders*. New York: International Universities Press.
- . (1972). Thoughts on narcissism and narcissistic rage. In *The search for the self* (Vol. 2, pp. 615–658). New York: International Universities Press.
- . (1974). *The restoration of the self*. New York: International Universities Press.
- . (1974). Remarks about the formation of the self. In *The search for the self* (Vol. 2). New York: International Universities Press.
- . (1978). The psychoanalytic treatment of narcissistic personality disorders. In *The search for the self: Selected writings of Heinz Kohut* (Vol. 1). New York: International Universities Press. (Original work published 1968)
- . (1979). The two analyses of Mr Z. *International Journal of Psychoanalysis*, 60, 1.
- . (1984). *How does analysis cure?* Chicago: University of Chicago Press.
- . (1990–1991). Introspection, empathy, and psychoanalysis: an examination of the relationship between mode of observation and theory. In his *The search for the self* (Vol. 1, pp. 205–232). New York: International Universities Press. (Original work published 1959.)
- . (1990–1991). The psychoanalytic treatment of narcissistic personality disorders. In his *The search for the self* (Vol. 1, pp. 477–509). New York: International Universities Press. (Original work published 1968.)
- . (1990–1991c). Thoughts on narcissism and narcissistic rage. In his *The search for the self* (Vol. 2, pp. 615–658). New York: International Universities Press. (Original work published 1972.)
- . (1991). Four basic concepts in self psychology. In *The search for the self: Selected writings of Heinz Kohut* (Vol. 4). New York: International Universities Press. (Original work published 1979)
- . (1991). Selected problems of self psychological theory. In *The search for the self: Selected writings of Heinz Kohut* (Vol. 4). New York: International Universities Press. (Original work published 1980)
- Kohut, Heinz, and Seitz, Philip. (1963). Concepts and theories of psychoanalysis. In Joseph M. Wepman and Ralph W. Heine (Eds.), *Concepts of personality* (pp. 113–141). Chicago: Aldine Press.
- Kojève, Alexandre. (1990). *L'idée du déterminisme dans la physique classique et dans la physique moderne*. Paris: Hachette. (Original work published 1932)
- Koning, André J. J. de, and Jenner, Frederick Alexander (Eds.). (1982). *Phenomenology and psychiatry*. London: Academic Press.

- Kosawa, Heisaku. (1954). Two kinds of guilt feelings: the Ajase complex. *Japanese Journal of Psychoanalysis*, 11. (Original work published 1931)
- Kouretas, Démétrios. (1949). Le complexe d'Io dans "Les suppliantes" et le "Prométhée enchaîné" d'Eschyle. *Revue française de psychanalyse*, 13 (3), 445–460.
- . (1957). Psychanalyse et mythologie: la névrose actuelle des Danaïdes. *Revue française de psychanalyse*, 21 (4), 597–602.
- Kourias, Eri, and Kourias, Georges. (1984). *Un cas de pratique psychanalytique relié à une errance hyperréaliste: la psychanalyse et la Grèce*. Athens: Société d'études de la culture néohellénique et de l'éducation.
- Kovács, Vilma. (1925). Ein Fall von "tic convulsif." *Internationale Zeitschrift für Psychoanalyse*, 11 (3), 318–324.
- . (1926). Das Erbe des Fortunatus. *Imago*, 12, (2–3), 321–327.
- . (1928). Beispiele zur aktiven Technik. *Internationale Zeitschrift für Psychoanalyse*, 16 (3), 405–408.
- . (1931). Wiederholungstendenz und Charakterbildung. *Internationale Zeitschrift für Psychoanalyse*, 17 (4), 449–463.
- . (1935). Lehranalyse und Kontrollanalyse. *Internationale Zeitschrift für Psychoanalyse*, 21 (4), 515–524.
- . (1936). Training and control-analysis. *International Journal of Psychoanalysis*, 17 (3), 346–354.
- Koyré, Alexandre. (1957). *From the Closed World to the Infinite Universe*. New York: Harper.
- . (1968). *Metaphysics and measurement: Essays in scientific revolution*. Cambridge, MA: Harvard University Press.
- Krüll, Marianne (1986). *Freud and His Father*. (Arnold J. Pomerans, Trans.). New York: W.W. Norton. (Original work published 1979)
- Kraepelin, Emil. (1971). *Dementia Praecox and Paraphrenia*. New York: Robert E. Krieger. (Original work published 1919)
- Kraus, Karl. (1975). *Cahier Karl Kraus*. Paris: L'Herne, Cahiers de l'Herne.
- . (1985). *Pro domo et mundo*. Paris: Gérard Lebovici.
- . (1986). *La nuit venue*. Paris: Gérard Lebovici.
- Krause, Rainer. (1998). *Allgemeine psychoanalytische Krankheitslehre*. Stuttgart: Kohlhammer.
- Kreisler, Léon. (1977). Enurésie. In *Encyclopédie médico-chirurgicale* (Vol. Pédiatrie, fasc. 4101-G-95). Paris: Encyclopédie médico-chirurgicale.
- . (1981). *L'enfant du désordre psychosomatique*. Toulouse: Privat.
- . (1982). L'économie psychosomatique de l'enfant asthmatique: à propos d'un cas d'asthme grave chez un préadolescent *Psychothérapies*, 2 (1), 15–24.
- . (1992). La prospettiva psicosomatica nella psicopatologia del lattante. In Fava, V.G., and Stern, D. (Eds.), *Modèles psychothérapeutiques au premier âge*. Paris: Masson.
- Kreisler, Léon, and Soulé, Michel. (1995). L'enfant prématuré. In *Nouveau traité de psychiatrie de l'enfant et de l'adolescent*. (p. 1893–1915). René Diatkine, et al. (Eds.). Paris: Presses Universitaires de France.
- Kreisler, Léon; Fain, Michel, and Soulé, Michel. (1974). *L'enfant et son Corps*. Paris: Presses Universitaires de France.
- Kress-Rosen, Nicolle. (1993). *Trois figures de la passion*. Paris: Arcanes.
- Kretschmer, Ernst. (1963). *Paranoïa et sensibilité*. Paris: Presses Universitaires de France. (Original work published 1927)
- Kris, Ernst, et al. (1954). Problems of infantile neurosis. *Psychoanalytic Study of the Child*, 9, 16–71.
- Kris, Ernst. (1951). Ego psychology and interpretation in psychoanalytic therapy. *Psychoanalytic Quarterly*, 20, 15–30.
- . (1952). *Psychoanalytic explorations in art*. New York: International Universities Press.
- . (1955). Neutralization and sublimation. *Psychoanalytic Study of the Child*, 10, 30–46.
- . (1956). On some vicissitudes of insight in psychoanalysis. *International Journal of Psychoanalysis* 37, 445–455.
- . (1956). The personal myth. *Journal of the American Psychoanalysis Association*, 4, 653–681.
- . (1975). *Selected papers of Ernst Kris*. New Haven, CT: Yale University Press.
- . (1979). *Psychoanalytische Kinderpsychologie*. Frankfurt am Main, Germany: Suhrkamp.
- Kris, Marianne. (1957). The use of prediction in a longitudinal study. *Psychoanalytic Study of the Child*, 12, 175–189.
- . (1983). Parents and siblings: Their mutual influences. *Psychoanalytic Study of the Child*, 38, 311–324.
- Kristeva, Julia. (1974). *La Révolution du langage poétique. L'Avant-garde à la fin du dix-neuvième siècle—Lautréamont et Mallarmé*. Paris: Seuil.



- . (1989). *Black Sun: Depression and Melancholia*. (Leon S. Roudiez, Trans.). New York: Columbia University Press. (Original work published 1987)
- . (2000). *The sense and non-sense of revolt* (Jeanine Herman, Trans.). New York: Columbia University Press. (Original work published 1996)
- Kronold, Edward. (1973). Otto Isakower (1899–1972). *International Journal of Psychoanalysis*, 54, 369.
- . (1979). Edith Jacobson, 1897–1978. *Psychoanalytic Quarterly*, 49, 505–507.
- Kubie, Lawrence S. (1960). *Practical and theoretical aspects of psychoanalysis*. New York: Praeger.
- . (1967). Relation of psychotic disorganization to the neurotic process. *Journal of the American Psychoanalytic Association*, 15, 626–640.
- . (1978). Distortion of the symbolic process in neurosis and psychosis. *Psychological Issues*, 44, 87–114.
- Kuehn, John L. (1965). Encounter at Leyden: Gustav Mahler consults Sigmund Freud. *Psychoanalytic Review*, 52, 345–364.
- Kulish, Nancy. (2002). Female sexuality: pleasure of secrets and the secret of pleasure. *Psychoanalytic Study of the Child*, 57, 151–176.
- . (2002). The psychoanalytic method from an epistemological viewpoint. *International Journal of Psychoanalysis*, 83, 491–495.
- Kulka, Raanan. (1988). Narcissism and neurosis—an opportunity for integration in psychoanalytic theory and technique. *International Journal of Psychoanalysis*, 69, 521–531.
- Kulovesi, Yrjö. (1933). *Psykoanalyysi*. Helsinki, Finland: Otava.
- Kumar R. Channi, Robson KM. (1984). A prospective study of emotional disorders in childbearing women. *British Journal of Psychotherapy*, 144, 35–47.
- Kurts, Nora. (1993). L'Enfant qui ne savait pas jouer. *Psychiatrie de l'Enfant* 36, no. 2, pp. 537–554.
- Kurzweil, Edith. (1989). *The Freudians: A comparative perspective*. New Haven: Yale University Press.
- . (1995). *Freudians and feminists*. Boulder, CO: Westview Press.
- Kutter, Peter. Germany. In *Psychoanalysis international: a guide to psychoanalysis throughout the world*. Vol. 1, Europe. (p. 114–136). Stuttgart-Bad Cannstatt: Frommann-Holzboog.
- LaBarre, Weston. (1961). Psychoanalysis in anthropology. *Science and Psychoanalysis*, 4, 10–20.
- Lacan, Jacques. (1927). *The practice and theory of individual psychology*. New York: Harcourt Brace.
- . (1927). *Understanding human nature* (Walter Béran Wolfe, Trans.). New York: Greenberg.
- . (1928–1930). *Die Technik der Individualpsychologie*. München: Bergmann.
- . (1932). *De la psychose paranoïaque dans ses rapports avec la personnalité*. Paris: Librairie le François.
- . (1936). Au-delà du “principe de réalité.” In his *Écrits*. Paris: Seuil, 1966, 73–92.
- . (1938). La vie mentale. *Encyclopédie française*, Vol. 8.
- . (1945). Le temps logique et l’assertion de certitude anticipée. Un nouveau sophisme. In *Écrits* (pp. 197–213).
- . (1958–1959). Le Séminaire-Livre VI, Le désir et son interprétation. (Desire and its interpretation), unpublished.
- . (1958). Intervention, in G. Favez: ‘Le rendez-vous avec le psychanalyste.’ *La Psychanalyse*, 4, 305–314.
- . (1958). The direction of the treatment and the principles of its power. In Bruce Fink (Trans.), *Écrits: A selection*. New York: W. W. Norton, 2002.
- . (1959). Á la mémoire d’Ernest Jones: sur la théorie du symbolisme. *Psychanalyse*, 5, 2–20.
- . (1961–62). *Le Séminaire-Livre IX, L’identification* (unpublished seminar).
- . (1966–1967). *Le Séminaire-Livre XIV, La Logique du fantasme*. Unpublished seminar.
- . (1966). *Écrits*. Paris: Le Seuil. *Schriften*. Olten, Switzerland: Walter-Verlag, 1973–1980. *Écrits: A Selection*. (Bruce Fink, Trans.). New York: Norton, 2002. *Scritti*. Torino, Italy: Einaudi, 1974. *Escritos*. San Angelo, Mexico: Siglo Veintiuno Editores, 1971–1975.
- . (1966). Commentaires sur la *Verwerfung*. In *Écrits*. Paris: Le Seuil. (Original work published 1956)
- . (1966). Jeunesse de Gide, ou la lettre et le désir. In his *Écrits*. Paris: Seuil.
- . (1966). Kant avec Sade. In his *Écrits*, pp. 765–790. Paris: Le Seuil. (Original work published 1963)
- . (1966). La science et la vérité. In *Écrits* (p. 855–878). Paris: Le Seuil.
- . (1970–1971). *Le séminaire-livre XVIII, d’un discours qui ne serait pas du semblant*. [On a discourse that might not be a semblance] (unpublished seminar).
- . (1970). Discours prononcé par J. Lacan le 6 décembre 1967 à l’École Freudienne de Paris. *Scilicet*, 2–3, 9–29.
- . (1970). Radiophonie. *Scilicet*, 2–3, 55–99.

- . (1971–1972). Le séminaire Livre XIX: ... Ou pire. Unpublished.
- . (1973–1974). Le Séminaire-Livre XXI, Les non-dupes errent. Unpublished seminar.
- . (1973). L'étourdit. *Scilicet*, 4, 5–52.
- . (1975–1976). *Le séminaire*. Book 23: *Le sinthome*. *Ornicar?*, 6–11.
- . (1975). La troisième, intervention de J. Lacan, le 31 octobre 1974. *Lettres de l'École Freudienne*, 16, 178–203.
- . (1975). Motifs du crime paranoïaque: le crime des sœurs Papin. In *De la psychose paranoïaque dans ses rapports avec la personnalité*. Paris: Le Seuil. (Original work published 1933)
- . (1976–1977). Le séminaire XXIII, 1975–76: Le sinthome. *Ornicar?* 6–11.
- . (1976). Conférences et entretiens dans les universités nord-américaines. *Scilicet*, 6–7, 5–63.
- . (1977). *Sur la passe*. *Ornicar?* 12–13.
- . (1978). *Le Séminaire-Livre II, Le Moi dans la théorie de Freud et dans la technique de la psychanalyse* (1954–55). Paris: Le Seuil.
- . (1978). *The four fundamental concepts of psychoanalysis*. (Alan Sheridan, Trans.). New York: W. W. Norton. (Original work published 1964)
- . (1982). Le symbolique, l'imaginaire et le réel. *Bulletin de l'Association Freudienne*, 1, 4–13.
- . (1982). Note italienne. *Ornicar?* 25, 7–10.
- . (1982). The seminar XXII of 21 January 1975: RSI. In Juliet Mitchell and Jacqueline Rose (Eds.), *Feminine sexuality*. New York: W. W. Norton.
- . (1984). *Les Complexes familiaux dans la formation de l'individu*. Paris: Navarin. (Original work published 1938)
- . (1985). Geneva lecture on the symptom (Russell Grigg, Trans.). *Analysis*, 1, 7–26. (Original work published 1975)
- . (1988). *The seminar of Jacques Lacan. Book 1: Freud's papers on technique (1953–1954)* (John Forrester, Trans.). (Original work published 1975)
- . (1988). *The seminar of Jacques Lacan. Book 2: The ego in Freud's theory and in the technique of psychoanalysis (1954–1955)* (Sylvana Tomaselli, Trans.). (Original work published 1978)
- . (1988). Introduction and reply to Jean Hypolite's presentation of Freud's *Verneinung*. In *The seminar of Jacques Lacan. Book 1: Freud's papers on technique, 1953–1954* (John Forrester, Trans.). New York: W. W. Norton. (Original work published 1954.)
- . (1988, Fall). Logical Time and the assertion of anticipated certainty: a new sophism. (Bruce Fink, Trans.). *Newsletter of the Freudian Field* 2, 2, 4–22. (Original work published 1945)
- . (1990). *Television: a challenge to the psychoanalytic establishment*. (Joan Copjec, Ed., and Denis Hollier, et al., Trans.). New York: W. W. Norton. (Original work published 1974)
- . (1990). Founding act. In *Television: a challenge to the psychoanalytic establishment* (Joan Copjec, Ed.). New York: Norton. (Original work published 1964)
- . (1990). Introduction to the Names-of-the-Father. In John Copjec (Ed.), *Television: A challenge to the psychoanalytic establishment*. New York: W.W. Norton. (Original work published 1963)
- . (1990). The other is missing. In John Copjec (ed.). *Television: A challenge to the psychoanalytic establishment*. New York: W.W. Norton. (Original work published 1963)
- . (1991). *Le Séminaire VIII. Le transfert (1960–61)*. Paris: Seuil.
- . (1993). *The seminar of Jacques Lacan: Book III, the psychoses (1955–1956)*. (Jacques-Alain Miller, Ed. and Russell Grigg, Trans.). New York: W. W. Norton.
- . (1994). *Le séminaire-livre IV, (1956–57), La relation d'objet*. Paris: Le Seuil.
- . (1995). Proposition of 9 October 1967 on the Psychoanalyst of the School (Russell Grigg, Trans.). *Analysis*, 6, 1–13. (Original work published 1968)
- . (1995). The position of the unconscious (Bruce Fink, Trans.). In Richard Feldstein, Bruce Fink, Maire Jaanus (Eds.), *Reading "Seminar XI": Lacan's four fundamental concepts of psychoanalysis*. New York: W. W. Norton. (Original work published 1960)
- . (1997). *The seminar of Jacques Lacan, Book VII, The ethics of psychoanalysis, (1959–1960)* (Dennis Porter, Trans.). New York: W. W. Norton, 1997.
- . (1998). *Le séminaire*. Book 5: *Les formations de l'inconscient, 1957–1958*. Paris: Seuil.
- . (1998). *The seminar of Jacques Lacan, book XX, on feminine sexuality: the limits of love and knowledge, encore*. (Bruce Fink, Trans.). New York: Norton. (Original work published 1972–1973)
- . (2001). *Autres écrits* (Jacques-Alain Miller, Ed.). Paris: Éditions du Seuil.
- . (2001). Joyce: le symptôme. In his *Autres écrits*. Paris: Seuil.
- . (2002). *Écrits: A selection* (Bruce Fink, Trans.). New York: Norton. (Original work published 1966)

- . (2002). On a question prior to any possible treatment of psychosis. *Écrits: A Selection* (Bruce Fink, Trans.). New York: W. W. Norton. (Original work published 1955–56)
- . (2002). The direction of the treatment and the principles of its power. In his *Écrits: A selection* (Bruce Fink, Trans., pp. 215–270). New York: W. W. Norton. (Original work published 1958)
- . (2002). The function and field of speech and language in psychoanalysis. In *Écrits: a selection* (Bruce Fink, Trans.). New York: Norton. (Original work published 1953)
- . (2002). The instance of the letter in the unconscious, or Reason since Freud. In *Écrits: A Selection* (pp. 138–168). (Bruce Fink, Trans.). New York: W. W. Norton. (Original work published 1966)
- . (2002). The mirror stage as formative of the I function, as revealed in psychoanalytic experience. In *Écrits: A Selection*. (Bruce Fink, Trans.). New York: Norton. (Original work published 1949)
- . (2002). The signification of the phallus. In *Écrits: A selection* (Bruce Fink, Trans.). New York: W. W. Norton. (Original work published 1958)
- . (2002). The subversion of the subject and the dialectic of desire in the Freudian subconscious. In *Écrits: A selection* (Bruce Fink, Trans.). New York: Norton.
- . (2004). *Le séminaire, Livre X: L'angoisse, 1962–1963*. Paris: Seuil.
- Lacan, Jacques, and Cénac, Michel. (1997). A theoretical introduction to the function of psychoanalysis in criminology, May 29, 1950 (Mark Bracher, Russell Grigg, and Robert Samuels, Trans.). *Journal for the Psychoanalysis of Culture and Society*, 1 (2). (Original work published 1951)
- Lachmann, Frank M., and Stolorow, Robert D. (1976). Idealization and grandiosity: developmental considerations and treatment implications. *Psychoanalytic Quarterly*, 45, 565–587.
- Lacoste, Patrick. (1986). Destins de la transmission. In *S. Freud: Vue d'ensemble des névroses de transfert* (pp. 165–210). Paris: Gallimard, N.R.F.
- . (1990). *L'étrange cas du Pr. M. Psychanalyse à l'écran*. Paris: Gallimard.
- Lacoue-Labarthe, Philippe, & Nancy, Jean-Luc. (1992). *The title of the letter: A reading of Lacan* (François Raffoul and David Pettigrew, Trans.). Albany: State University of New York Press. (Original work published 1973)
- Laforgue, René. (1926). Verdrängung und Skotomisation. *Internationale Zeitschrift für Psychoanalyse*, 12, 54–65.
- . (1928). Überlegungen zum Begriff der Verdrängung. *Internationale Zeitschrift für Psychoanalyse*, 4, 371–74.
- . (1932). *The defeat of Baudelaire: A psychoanalytical study of the neurosis of Charles Baudelaire* (Herbert Agar, Trans.). London: Hogarth Press. (Original work published 1931)
- . (1936). La névrose familiale (IXe Conférence des psychanalystes de langue française). *Revue française de psychanalyse*, 9 (4), 327–359.
- . (1941). *Psychopathologie de l'échec*. Marseille: Les Cahiers du Sud.
- Laforgue, René, and Allendy, René. (1924). *La psychanalyse et les Névroses*. Paris: Payot.
- Lagache, Daniel. (1947). *La jalousie amoureuse: psychologie descriptive et psychanalyse*. Paris: Presses Universitaires de France.
- . (1950). Homosexuality and jealousy. *International Journal of Psychoanalysis*, 31 (1–2), 24–31.
- . (1961). La psychanalyse et la structure de la personnalité. Colloque de Royaumont, 1958. *La Psychanalyse*, 6.
- . (1962). La conception de l'homme dans l'expérience psychanalytique. In *Oeuvres Complètes* (Vol. 4, 1956–1962: Agressivité. Structure de la personnalité et autres travaux; E. Rosenblum (éd.), Paris: Presses Universitaires de France, 1977–1982.
- . (1963). *Psychoanalysis*. New York: Walker. (Original work published 1955)
- . (1964). Fantaisie, réalité, vérité. *Revue française de psychanalyse*, 28 (4), 515–538.
- . (1977–1986). *Oeuvres* (6 vols.). Paris: Presses Universitaires de France.
- . (1977). Contribution à l'étude des idées d'infidélité homosexuelle dans la jalousie. (Communication au XVe Congrès International de Psychanalyse. Paris 1938). In *Les hallucinations verbales et travaux cliniques* (Oeuvres I [1932-1946], pp. 225–242). Paris: Presses Universitaires de France. (Original work published 1938)
- . (1981). *La Jalousie amoureuse: psychologie descriptive et psychanalyse*. 2d. ed. Paris: Presses Universitaires de France. (Original work published 1947)
- . (1982). La psychanalyse et la structure de la personnalité. In his *Oeuvres* (pp. 163–78). Paris: Presses Universitaires de France. (Original work published 1962)

- . (1984). La sublimation et les valeurs. In *Oeuvres complètes 5*. Paris: Presses Universitaires de France. (Original work published 1962)
- . (1986). Adresses présidentielles. In *Oeuvres* (Vol. VI. La folle du logis, la psychanalyse comme science exacte, pp. 149–158). Paris: Presses Universitaires de France. (Reprinted from *Bulletin intérieur de l'Association psychanalytique de France*, 1964.)
- . (1993). *The Work of Daniel Lagache: Selected Papers 1938-1964*. London: Karnac Books.
- La Grange, Henry-Louis de (1973). *Gustav Mahler*, Vol. III *Le génie Foudroyé, 1907–1911*. Paris: Fayard, 1984.
- Laible, Eva. (1989). Über Sigmund Freuds Gymnasialzeit, 125 Jahre Bg./ B.R.G. Wien II. *Festschrift Sigmund Freud, dem berühmtesten Schüler unseres Gymnasiums zur 50. Wiederkehr seines Todestages gewidmet*. Vienna: Festschrift Sigmund Freud, pp.19–30.
- . (1993). Through privation to knowledge: unknown documents from Freud's university years. *International Journal of Psychoanalysis*, 74, 4, 775–790.
- Laier, Michael. (1994). *Das Frankfurter Psychoanalytische Institut (1929-1933). Anfänge der Psychoanalyse in Frankfurt am Main*, Münster: LIT.
- Lainé, Tony. (1991). Droit et accession au statut d'adulte. *Nervure*, 4 (5), 26–30.
- . (1994, Sept.–Oct.). Conditions institutionnelles de la restauration des images parentales. *Courrier de Suresnes* (Centre national d'études et de formation pour l'enfance inadaptée), 61.
- Lainé, Tony, and Lanouzière, Jacqueline. (1972). La relation d'objet chez l'enfant autiste. *Psychiatrie de l'enfant*, 15 (2), 287–398.
- Lainé, Tony, Lanouzière, Jacqueline, and Delage, M. (1972). Conflit, répétition et pathologie du caractère. *Neuropsychiatrie de l'enfance et de l'adolescence*, 20 (5).
- Laine, Aira; Parland, Helena, and Roos, Esa. (1997). *Pssykoanalyysin, uranuurtajat Suomessa*. Kemijärvi, Finland: Suomen Psykoanalyttinen Yhdistys R.Y.
- Laing, Ronald. (1960). *The divided self*. London: Tavistock Publications.
- . (1967). *The politics of experience*. London: Tavistock Publications.
- . (1985). *Wisdom, madness, and folly*. New York: McGraw-Hill.
- Laing, Ronald, and Esterson, Aaron. (1964). *Sanity, Madness and the Family*. London, Tavistock Publications.
- Lalande, André. (1926). *Vocabulaire technique et critique de la philosophie*. Paris: Presses Universitaires de France.
- La Mettrie, Julien Offray de. (1746). *Man a machine*. La Salle, IL: Open Court Classics, 1912.
- Lamour, Martine, and Lebovici, Serge (1989). Les interactions du nourrisson avec ses partenaires. *Encyclopédie médico-chirurgicale* (Vol. *Psychiatrie*). Paris: E.M.-C., fasc. 37-190-B-60.
- Lampl, Hans. (1940). Einige Analogien in der Verhaltensweise von Vögeln und psychischen Mechanismen beim Menschen, *Internationale Zeitschrift für Psychoanalyse*, 25, 399–408.
- Lampl, Hans, and Feitelberg, S. (1935). Methode zur Messung der Wärmetönung an der Grosshirnrinde. Wärmetönung der Grosshirnrinde bei Erregung und Ruhe bzw. Funktionshemmung, *Archiv für experimentelle Pathologie und Pharmakologie*, 177, 600–613, 726–736.
- Lampl-de Groot, Jeanne. (1985). *Man and mind: Collected papers of Jeanne Lampl-de Groot, M.D.* New York: International Universities Press.
- Landauer, Karl. (1938). Affects, passions, and temperament. *International Journal of Psychoanalysis*, 19, 388–415.
- . (1939). Some remarks on the formation of the anal-erotic character. *International Journal of Psychoanalysis*, 20, 418–425.
- . (1991). *Theorie der Affekte und andere Schriften zur Ich-Organisation*. Frankfurt, Fischer.
- Lang, Jean-Louis. (1978). *Aux frontières de la psychose infantile*. Paris: Presses Universitaires de France.
- . (1995). Georges Heuyer, l'art médical et la psychanalyse. *Revue de neuropsychiatrie infantile*, 43 (6), 269–273.
- . (1996). La scission de 1963. *Cliniques méditerranéennes*, 49–50, 73–77.
- Lang, Jean-Louis. (1997). *Georges Heuyer, fondateur de la pédo-psychiatrie : un humaniste du XXe siècle*. Paris: Expansion scientifique française.
- Langer, Marie. (1947). Antisemitismo, paranoia y el testamento del doctor Ley. *Revista de psicoanálisis de la Asociación psicoanalítica argentina*, V, 1: 93.
- . (1957). *Fantasías eternas a la luz del psicoanálisis*. Buenos Aires: Nova. APA.
- . (1957). *Psicoterapia del grupo, su enfoque psicoanalítico*. Buenos Aires: Paidós.
- . (1959). Ideología e idealización. *Revista de psicoanálisis de la Asociación psicoanalítica argentina*, 16 (4), 417.

- . (1989). *Marie Langer, From Vienna to Managua: Journey of a Psychoanalyst* (Margaret Hooks, Trans.). London: Free Association Books.
- . (1992). *Motherhood and sexuality*. (Nancy Caro Hollander, Trans.). New York: Guilford Press. (Original work published 1951)
- Langs, Robert, and Searles, Harold F. (1980). *Intrap-sychic and interpersonal dimensions of treatment*. New York: Jason Aronson.
- Lantéri-Laura, Georges. (1963). *La psychiatrie phénoménologique: Fondements philosophiques*. Paris: Presses Universitaires de France.
- . (1966). *Les Apports de la linguistique à la psychiatrie contemporaine*. Paris: Masson.
- . (1992). *Psychiatrie et connaissance*. Paris: Sciences en situation.
- . (1993). *Histoire de la phrénologie*. Paris: Presses Universitaires de France.
- . (1994). *Recherches psychiatriques: Vol. 1. Sur le langage*. Paris: Sciences en situation.
- Lantéri-Laura Georges, and Del Pistoia, Luciano. (1984). Névrose obsessionnelle. *Encyclopédie médico-chirurgicale, Psychiatrie*. Paris: E.M.-C., fasc. 37-370-A-10, pp. 1–20.
- Lapassade, Georges. (1990). *La Transe*. Paris: Presses Universitaires de France.
- Laplanche, Jean. (1970). *Vie et mort en psychanalyse*. Paris: Flammarion.
- . (1976). *Life and death in psychoanalysis* (Jeffrey Mehlman, Trans.). Baltimore: Johns Hopkins University Press. (Original work published 1970)
- . (1980–87). *Problématiques*. Paris: Presses Universitaires de France.
- . (1980). *Problématiques II: Castration, symbolisations*. Paris: Presses Universitaires de France.
- . (1980). *Problématiques III, la sublimation*. Paris: Presses Universitaires de France.
- . (1981). *Problématiques IV, L'Inconscient et le Ça*. Paris: Presses Universitaires de France.
- . (1986). La pulsion de mort dans la théorie de la pulsion sexuelle. *La Pulsion de mort* (pp. 11–26). Paris: Presses Universitaires de France.
- . (1987). *Nouveaux Fondements pour la psychanalyse*. Paris: Presses Universitaires de France.
- . (1989). *New foundations for psychoanalysis* (David Macey, Trans.). Cambridge, MA: Basil Blackwell. (Original work published in 1987)
- . (1992). *La révolution Copernicienne inachevée*. Paris: Abider.
- . (1993). *Le fourvoisement biologisant de la sexualité chez Freud*. Paris: Les Empêcheurs de penser en rond.
- . (1995). La psychanalyse dans la communauté scientifique. *Cliniques Méditerranéennes*, 45–46, 33–42.
- . (1997). Le pré-génital freudien à la trappe: après l'analyse. *Revue française de psychanalyse*, 61, 4: 1357–1369.
- . (1997). The theory of seduction and the problem of the other. *International Journal of Psychoanalysis*, 78, 653–666.
- . (1998). Temporalité et traduction. In *Le Primat de l'autre*. Paris: Flammarion.
- . (1999). *Essays on otherness* (Luke Thurston, Philip Slotkin, and Leslie Hill, Trans.). London and New York: Routledge.
- . (1999). Notes on afterwardsness. In *Essays on Otherness*. (John Fletcher, Ed., and Luke Thurston, Philip Slotkin, and Leslie Hill, Trans.). London, New York: Routledge. (Original work published 1998)
- . (1999). The drive and its source-object. In *Essays on Otherness*. (John Fletcher, Ed.; Leslie Hill, Trans.; pp. 117–32.). London: Routledge. (Original work published 1984)
- . (2001). From the restricted to the generalized theory of seduction. In Corveleyn, J., and Van Haute, P. (Eds.), *Seduction, suggestion, psychoanalysis* (pp. 9–24). Belgium: Presses Universitaires de Louvain. (Original work published 1999)
- Laplanche, Jean, and Pontalis, Jean-Bertrand. (1968). Fantasy and the origins of sexuality. *International Journal of Psychoanalysis*, 49, 1ff. (Original work published 1964)
- Laplanche, Jean, and Pontalis, Jean-Bertrand. (1973). *The language of psycho-analysis*. (Donald Nicholson-Smith, Trans.). New York: Norton. (Original work published 1967)
- Lapuz, Lourdes. (1973). *Children of Oedipus*. Quezon City, Philippines: New Day Publications.
- . (1979). *Marriage counselling*. Quezon City, Philippines: New Day Publications.
- Laufer, Moses. (1996). The psychoanalyst of the adolescent. *Psychoanalytic Study of the Child*, 51, 512–521.
- Laufer, Moses (Ed.). (1995). *The suicidal adolescent*. Madison, CT: International Universities Press.
- Laufer, Moses, and Laufer, M. Eglé. (1984). *Adolescence and developmental breakdown: A psychoanalytic view*. New Haven: Yale University Press.

- Launay, Jacques. (1983). Le Rêve-éveillé et l'Inconscient. *La Serrure et le Songe*. Paris: Economica.
- Laurent, Éric (1986). Lectures de Dora. In Fondation du champ freudien, Rencontre internationale, *Hystérie et obsession* (pp. 29–42). Paris: Navarin.
- Lavie, Jean-Claude. Parler à l'analyste. (1972). *Nouvelle Revue de psychanalyse*, 5 287–298.
- Lawrence, David Herbert, and Richthofen, Frieda von. (1961). *The memoirs and correspondence*. London: E.W. Tedlock Jr.
- Lázaro, J. (1991). *Las Traducciones al español de Freud: Historia y crítica, actas del IX congreso de historia de la medicina*. Saragossa: Prensas Universitarias y Ayuntamiento de Saragossa.
- Laznik, Marie-Christine. (1993). Pour une théorie lacanienne des pulsions. *Le Discours psychanalytique, revue de l'Association freudienne*, 10
- Laznik-Penot, Marie-Christine. (1993). Du ratage de l'instauration de l'image du corps au ratage de l'installation du circuit pulsionnel. In *La clinique de l'autisme*. Paris: Point Hors Ligne.
- . (1995). *Vers la parole: trois enfants autistes en psychanalyse*. Paris: Denoël.
- Le Beuf, Diane, Perron, Roger, and Pragier, Georges (eds.). (1998). *Construire l'histoire*. Paris: Presses Universitaires de France.
- Le Bon, Gustave. (1910). *La psychologie politique et la défense sociale*. Paris: Flammarion.
- . (1980). *The French Revolution and the psychology of revolution*. With a new introduction by Robert A. Nye. New Brunswick, NJ: Transaction Books. (Original work published 1912)
- . (1995). *The crowd*. New Brunswick, NJ: Transaction Publications. (Original work published 1895)
- Le Goff, Jean-Pierre. (1998). *Mai 68, l'héritage impossible*. Paris: Le Découverte.
- Le Goues, Gérard, and Roger Perron (Eds.). (1996). *Scènes originaires*. Monographs of the *Revue française de psychanalyse*. Paris: Presses Universitaires de France.
- Le Guen, Claude. (1974). *L'Oedipe originaire*. Paris: Payot.
- . (1992). *Le refoulement*. Paris: Presses Universitaires de France.
- . (1995). Le principe de réalité psychique. *Revue française de psychanalyse*, 59 (1), 9–25.
- Le Guen, Claude, et al. (1986). Le refoulement (les défenses). *Revue française de psychanalyse*, 50, 1.
- Le Moigne, Jean-Louis. (1977). *La théorie du système général: théorie de la modélisation*. Paris: Presses Universitaires de France.
- Le Rider, Jacques. (1982). *Le cas Otto Weininger: Racines de l'antiféminisme et de l'antisémitisme*. Paris: Presses Universitaires de France.
- . (1990). *Modernité viennoise et crises de l'identité*. Paris: Presses Universitaires de France.
- . (1992). Un texte retrouvé : la première version d'« Actuelles sur la guerre et sur la mort » (part 2). *Revue internationale d'histoire de la psychanalyse*, 5, 599–611.
- . (1993). Kultur contre civilisation. *Topique*, 52, 273–287.
- Lear, Jonathan. (1990). *Love and its place in nature: A philosophical interpretation of freudian psychoanalysis*. New York: Farrar, Straus & Giroux.
- Lebovici, Serge. (1960). La relation objectale chez l'enfant. *Psychiatrie de l'Enfant* 1, 3, 147–226.
- . (1962). Sur la notion de carence maternelle. In *La carence de soins maternels, réévaluation de ses effets*. Geneva: Organisation Mondiale de la Santé.
- . (1979). Anne Berman. *Revue française de psychanalyse*, 43 (3), 476.
- . (1980). L'expérience du psychanalyste chez l'enfant et chez l'adulte devant le modèle de la névrose infantile et de la névrose de transfert. *Revue Française de Psychanalyse*, 64, 5–6, 733–857.
- . (1983). *Le nourrisson, la mère et le psychanalyste*. Paris: Le Centurion.
- . (1989). *Psychopathologie du bébé*. Paris: Presses Universitaires de France.
- . (1991). La dépendance du nouveau-né. In Catherine Dechamp–Le Roux (Ed.), *Figures de la dépendance, autour d'Albert Memmi* (pp. 29–39). Paris: Presses Universitaires de France.
- . (1997). Défense et illustration du concept de narcissisme primaire. Les avatars du narcissisme primaire et le processus de subjectification. *Psychiatrie de l'enfant*, 40, (2), 429–463.
- Lebovici, Serge, and A. Le Nestour. (1969). À propos des phobies scolaires graves. *Psychiatrie de l'Enfant*, 20, 2, 383–432.
- Lebovici, Serge, and Diatkine, René. (1954). Étude des fantasmes chez l'enfant. *Revue française de psychanalyse*, 18 (1), 108–155.
- . (1962). Fonction et signification du jeu chez l'enfant. *Psychiatrie de l'Enfant* 4, 207–253.
- Lebovici, Serge, and Solnit, Albert J. (Eds.). (1982). *La formation du psychanalyste*. Paris: Presses Universitaires de France.

- taires de France. Monographies de l'Association psychanalytique internationale.
- Lebovici, Serge, and Soulé, Michel. (1970). *La connaissance de l'enfant par la psychanalyse*. Paris: Presses Universitaires de France.
- Lebovici, Serge, Diatkine, René, and Kestemberg, Evelyne. (1958). Bilan de dix ans de thérapeutique par le psychodrame chez l'enfant et l'adolescent. *Psychiatrie de l'enfant*, 1 (1), 63–180.
- Lebovici, Serge, Diatkine, René, and Soulé, Michel. (1985). *Traité de psychiatrie de l'enfant et de l'adolescent*. Paris: Presses Universitaires de France.
- . (1995). *Nouveau traité de psychiatrie de l'enfant et de l'adolescent*. Second edition. Paris: Presses Universitaires de France.
- Lechat, Fernand. (1952). Jamais deux sans trois. *Revue Française de Psychanalyse*, 17 (4), 518–540.
- . (1955). Du principe de sécurité. (rapport). *Revue Française de Psychanalyse*, 19 (1–2), 11–101.
- . (1956). Notes sur les premières relations objectales et leurs conséquences à l'âge adulte. *Bulletin de l'Association des psychanalystes de Belgique*, 14.
- Leclaire, Serge. (1971). *Démasquer le réel*. Paris: Seuil.
- . (1981). *Rompre les charmes*. Paris: InterÉditions.
- . (1991). *État des lieux de la psychanalyse*. In collaboration with APUI. Paris: Albin Michel.
- . (1998). *Écrits pour la psychanalyse*. Paris: Le Seuil-Arcanes.
- . (1998). *A child is being killed: On primary narcissism and the death drive*. (Marie-Claude Hays, Trans.). Stanford: Stanford University Press. (Original work published 1975)
- . (1998). *Psychoanalyzing: On the order of the unconscious and the practice of the letter*. (Peggy Kamauf, Trans.). Stanford: Stanford University Press. (Original work published 1968)
- Lecourt, Dominique. (2001). *The mediocracy: French philosophy since the mid-1970s*. (Gregory Elliott, Trans.). London-New York: Verso. (Original work published 1999)
- Leeuw, Pieter Jakob van der. (1958). On the preoedipal phase of the male. *International Journal of Psychoanalysis*, 39, 112–115.
- . (1968). The psychoanalytic society, *International Journal of Psychoanalysis*, 49, 160–164.
- . (1969). Concernant le concept de défense. *Revue française de psychanalyse*, 33, 5–23.
- . (1971). On the development of the concept of defence. *International Journal of Psychoanalysis*, 52, 51–58.
- . (1977). L'impact de la correspondance Freud-Jung sur l'histoire des idées. *Revue française de psychanalyse*, 41, 439–463.
- Lefebvre, P. (1988). The psychoanalysis of a patient with ulcerative colitis. *International Journal of Psychoanalysis*, 69, 43–54.
- Legendre, Pierre. (1989). *Le crime du caporal Lortie, traité sur le père*. Paris: Fayard.
- Legrand du Saule, Henri. (1989). *Le delire des persecutions*. Paris: G.R.E.C.
- Lehrman, Philip R. (1927). The fantasy of not belonging to one's family, *Archives of Neurology and Psychiatry*, 18, 1015–1023.
- . (1939). Some unconscious determinants in homicide. *Psychoanalytic Quarterly*, 13, 605–621.
- . (1948). A. A. Brill in American Psychiatry, *Psychoanalytic Quarterly*, 17 (2), 155–160.
- . (1951). Fritz Wittels, 1880–1950, *Psychoanalytic Quarterly*, 20 (1), 96–104.
- Lejeune, Philippe. (1974). *Le pacte autobiographique*. Paris: Seuil.
- Lekeuche, Philippe and Mélon, Jean. (1990). *Dialectique des pulsions*. Bruxelles: De Boeck-Université.
- Lelong, Marcel, and Lebovici, Serge. (1955). Problèmes psychologiques et psychopathologiques posés par l'enfant à l'hôpital. *Archives françaises de pédiatrie* XII (2), 349–367.
- Lemérer, Brigitte. (1997). *Les Deux Moïse de Freud (1914–1939). Freud et Moïse: écritures du père 1*. Ramonville-Saint-Agne: Érés.
- Lemaire, Jean G. (1964). *La Relaxation*. Paris: Payot.
- Lensing, Leo A. (1989). “Geistige Väter” und “Das Kindweib.” Sigmund Freud, Karl Kraus und Irma Karczewska in der biographie von Fritz Wittels. *International Forum of Psychoanalysis*, 30, 430–431.
- . (1996). “Freud and the child woman” or “The Kraus affair”? A textual “reconstruction” of Fritz Wittels's psychoanalytic autobiography. *German Quarterly*, 69 (3).
- Lesky, Erna. (1965). *Die Wiener medizinische schule. 19 Jahrhundert*. Graz-Köln: Hermann Böhlhaus.
- . (1976). *The Vienna medical school of the 19th century* (L. Williams and I. S. Levij, Trans.). Baltimore, MD: Johns Hopkins University Press. (Original work published 1965)

- Lester, Eva P. (1976). On the psychosexual development of the female child. *Journal of the American Academy of Psychoanalysis*, 4, 515–528.
- Leuba, John. (1934). Compte rendu VIII Conference des psychanalystes de langue française. *Revue française de psychanalyse*, 7, 116–136.
- . (1936). La famille névrotique et les névroses familiales. *Revue française de psychanalyse*. 9 (3), 360–419.
- . (1939). Batrachomyomachie: Document pour la défense et illustration du thème oedipien. *Revue française de psychanalyse*, 12 (1), 55–79.
- Leupold-Löwenthal, Harald. (1989). Die Vertreibung der Familie Freud 1938. *Psyche-Zeitschrift für Psychoanalyse und ihre Anwendungen*, 43 (10), 908–928.
- Leupold-Löwenthal, Harald, Lobner, Hanz, and Scholz-Strasser, Inge. (1994). *Sigmund-Freud Museum Katalog*. Vienna: Christian Brandstätter.
- Leupold-Löwenthal, Harald, Lobner, Hans, and Scholz Strasser, Inge (Eds.). (1995). *Sigmund Freud Museum: Berggasse 19, Vienna* (Thomas Roberts, Trans.). Corte Madera, CA: Gingko Press.
- Levi Bianchini, Marco. (1995). *Biolibido: antologia di scritti psicoanalitici (1920–1936)*. Chieti, Italy: Métis.
- Lévi-Strauss, Claude. (1949). *Les structures élémentaires de la parenté*. Paris: Presses Universitaires de France. Reprinted 1968, The Hague: Mouton.
- . (1962). *Totemism*. (Rodney Needham, Trans.). London: Merlin Press, 1964, c1962.
- . (1963). *Structural anthropology* (Claire Jacobson and Brooke Grundfest Schoepf, Trans.). New York: Basic Books. (Original work published 1949)
- . (1969–1981). *Introduction to a science of mythology* (vols. 1–4). New York: Harper & Row.
- . (1969). *The elementary structures of kinship* (James Harle Bell, John Richard von Sturmer and Rodney Needham, Trans.). Boston: Beacon Press. (Original work published 1949)
- Levin, Fred M. rep. (1990). Panel: sadism and masochism in neurosis and symptom formation. *Journal of the American Psychoanalytic Association*, 38, 789–804.
- Levinas, Emmanuel. (2000). *Alterity and transcendence*. (Michael B. Smith, Trans.). New York: Columbia University Press, 2000. (Original work published 1995)
- Levine, Howard. (Ed.). (1990). *Adult analysis and childhood sexual abuse*. Hillsdale, NJ: Analytic Press.
- Levinson, Daniel J. (1978). *The seasons of a man's life*. New York: Ballantine Books.
- Levy, Ghyslain. (1986, July). Un patient est remboursé, ou Variations sur le thème du paiement et de ses diverses alternatives dans la situation analytique. *Psychoanalystes*, 20, 21–23.
- Lévy-Bruhl, Odile, and Aubry, Jenny. (1956). L'adaptation à l'école maternelle. *Enfance*, 1.
- Lewes, Kenneth. (1988). *The psychoanalytic theory of male homosexuality*. New York: Simon & Schuster.
- Lewin, Bertram D. (1916–1917a [1915–1917]). Introductory lectures on psycho-analysis. *SE*, 15–16.
- . (1933). The body as phallus. *Psychoanalytic Quarterly*, 2, 24–47.
- . (1935). Claustrophobia. *Psychoanalytic Quarterly* 4, 227–233.
- . (1949). Sleep, the mouth and the dream screen. *Psychoanalytic Quarterly*, 15, (4), 419–34.
- Lewin, Betram D. (Ed.). (1966). *On Character and Libido Development. Six Essays by Karl Abraham*, New York: W. W. Norton & Co. Arlow.
- Lewinter, Roger. (1990). *Georg Groddeck: Studien zu Leben und Werk*. Frankfurt am Main: S. Fischer.
- Lewis, Nolan. (1966). Smith Ely Jelliffe 1866–1945: Psychosomatic medicine in America. In Franz Alexander, S. Eisenstein, Martin Grotjahn (Eds.), *Psychoanalytic Pioneers* (pp. 224–234). New York and London: Basic Books,
- Leys, Ruth. (1990). Adolf Meyer: a biographical note. In Ruth Leys and Rand B. Evans (Eds.), *Defining American psychology: the correspondence between Adolf Meyer and Edward Bradford Titchener*. Baltimore, MD: Johns Hopkins University Press.
- Lieberman, David. (1962). *La comunicación en terapia psicoanalítica*. Buenos Aires: Eudeba.
- . (1971–72). *Linguística, interacción comunicativa y proceso psicoanalítico*. Buenos Aires: Nueva Visión.
- . (1975). *Psicoanálisis y semiótica*. Buenos Aires: Paidós.
- . (1976). *Comunicación y psicoanálisis*. Buenos Aires: Alex.
- Lichtenberg, Joseph D. (1991). Fear, phobia, and panic. *Psychoanalytic Inquiry*, 11, 395–415.
- . (1994). How libido theory shaped technique (1911–1915). *Journal of the American Psychoanalytic Association*, 42, 727–740 .
- Lichtenberg, Joseph D., and Slap, Joseph W. (1973). Concept of splitting: defense mechanisms; representations. *Journal of the American Psychoanalytic Association*, 21, 772–787.



- Lichtenstein, Heinz. (1961). Identity and sexuality. In *Dilemma of human identity*. New York: Jason Aronson.
- . (1983). Identity and sexuality. *The dilemma of human identity*. New York: Jason Aronson.
- Lieberman, E. James. (1979). The Rank-Wilbur correspondence. *Journal of the Otto Rank Association*, Vol. 14, No. 1, pp. 7–24.
- . (1985). *Acts of will: The life and work of Otto Rank*. New York: The Free Press.
- Lilamand, Martine. (1980). René Laforgue, fondateur du mouvement psychanalytique français, sa vie, son œuvre. Certificat d'études spéciales de psychiatrie. Créteil: Université de Paris.
- Limentani, Adam. (1972). Assessment of analysability: major hazard in selection. *International Journal of Psychoanalysis*, 53, 351–362.
- . (1986). Eugenio Gaddini (1916–1985). *International Journal of Psychoanalysis*, 67, 373–374.
- . (1986). Variations on some Freudian themes. *International Journal of Psychoanalysis*, 67, 235–244.
- . (1989). *Between Freud and Klein: The psychoanalytic quest for knowledge and truth*. London: Free Association Books.
- . (1991). Neglected fathers in aetiology: treatment of sexual deviations. *International Journal of Psychoanalysis*, 72, 573–584.
- . (1994). On treatment of homosexuality. *Psychoanalytic Psychotherapy*, 8.
- . (1996). A brief history of the International Psychoanalytical Association. *International Journal of Psychoanalysis*, 77, 149–156.
- Lipton, Samuel D. (1977). The advantages of Freud's technique as shown in the analysis of the ratman. *International Journal of Psychoanalysis*, 58, 255–274.
- Litowitz, Bonnie. (1998). An expanded developmental line for negation. *Journal of the American Psychoanalytic Association*, 46, 121–148.
- Litowitz, Bonnie, et al. (2003). The contemporary psychoanalyst at work. *Journal of the American Psychoanalytic Association*, 51, 9–24.
- Little, Margaret. (1960). On basic unity. *International Journal of Psychoanalysis*, 41, 377–384.
- Lockot, Regine. (1985). *Erinnern und Durcharbeiten: zur Geschichte der Psychoanalyse und Psychotherapie im Nationalsozialismus*. Frankfurt am Main: S. Fischer.
- . (1994). *Die Reinigung der Psychoanalyse: die deutsche psychoanalytische Gesellschaft im Spiegel von Dokumenten und Zeitzeugen (1933–1951)*. Tübingen: Diskord.
- . (1995). Mésusage, disqualification et division au lieu d'expiation. *Topique*, 57, 245–256.
- Loewald, Hans W. (1951). Ego and reality. *International Journal of Psychoanalysis*, 32, 10–18.
- . (1962). Superego and time. *International Journal of Psychoanalysis*, 43, 264–268.
- . (1971). Some considerations on repetition and repetition compulsion. *International Journal of Psychoanalysis*, 52, 59–66.
- . (1971). The transference neurosis: comments on the concept, phenomenon. *Journal of the American Psychoanalytic Association*, 19, 54–66.
- . (1973). Some instinctual manifestations of superego formation. *Annual of Psychoanalysis*, 1, 104–116.
- . (1974). Current status of the concept of infantile neurosis: Discussion. *Psychoanalytic Study of the Child*, 29, 183–190.
- . (1978). Instinct theory, object relations, and psychic-structure. *Journal of the American Psychoanalytic Association*, 26, 493–506.
- . (1979). The waning of the oedipus complex. *Journal of the American Psychoanalytic Association*, 27, 751–776.
- . (1985). Oedipus complex and development of self. *Psychoanalytic Quarterly*, 54, 435–443.
- . (1986). Transference-countertransference. *Journal of the American Psychoanalytic Association*, 34, 275–288.
- . (1988). *Sublimation: inquiries into theoretical psychoanalysis*. New Haven: Yale University Press.
- . (1988). In search of nature: Metapsychology, metaphysics, projection. *Annual of Psychoanalysis*, 16, 49–54.
- Loewenberg, Peter. (1985). *Decoding the past: the psychohistorical approach*. New Brunswick, NJ: Transaction.
- Loewenstein, Rudolph M. (1928). La technique psychanalytique. *Revue française de psychanalyse*, 2 (1), 113–134.
- . (1932). Un cas de jalousie pathologique. *Revue française de psychanalyse*, 5 (1), 554–585.
- . (1935). *La conception psychanalytique des troubles de la puissance génitale de l'homme*. Paris: Denoël & Steele.
- . (1950). Conflict, autonomous ego development during the phallic phase. *Psychoanalytic Study of the Child*, 5, 47–52.
- . (1952). *Christians and Jews; A psychoanalytical study*. New York: International Universities Press.

- . (1958). Remarks on some variations in psycho-analytic technique. *International Journal of Psychoanalysis*, 39, 202–210.
- . (1964). Symptom formation and character formation. *International Journal of Psychoanalysis*, 45, 155–157.
- . (1965). Observational data and theory in psychoanalysis. In M. Schur (Ed.): *Drives, affects, behaviour. Essays in memory of Marie Bonaparte*. Vol. 2. New York: International Universities Press.
- Loewenstein, Rudolph M., Kris, Ernst, and Hartmann, Heinz. (1975). *Éléments de psychologie psychanalytique*. Paris: Presses Universitaires de France.
- Loewenstein, Rudolph, et al. (Eds.). (1966). *Psychoanalysis: a general psychology*. New York: International Universities Press.
- Lohmann, Hans-Martin. (1987). *Alexander Mitscherlich mit Selbstzeugnissen und bilddokumenten*. Reinbek: Rowohlt.
- Lohser, Beate, and Newton, Peter. (1996). *Unorthodox Freud: the view from the couch*. New York, Guilford Press.
- Lombard, Pearl. (1986). Le silence de la mère ou vingt ans après. *Bulletin de la Société de psychanalyse de Paris*, 9, p. 33–48.
- Lorand, Sándor. (1946). *Technique of psychoanalytic therapy*. New York: International Universities Press.
- . (1950). *Clinical studies in psychoanalysis*. New York: International Universities Press.
- . (1963). Interview with Lawrence Kolb M.D. *Sándor Lorand papers*. Library of Congress: Washington, DC. 1963.
- Lorand, Sándor (Ed.). (1951). *The Yearbook of Psychoanalysis* (Vol. 6). New York: International Universities Press.
- Lorand, Sándor, and Schneer, Henry (Eds.). (1961). *Adolescent: Psychoanalytic Approach to Problems and Therapy*. New York: Paul B Hoeber Medical Division of Harper & Brothers.
- Lothane, Zvi. (1992). *In defense of Schreber: soul murder and psychiatry*. Hillsdale, NJ: Analytic Press.
- Low, Barbara. (1924). Psycho-analysis and education. In Ernest Jones (Ed.), *Social aspects of psycho-analysis*. London: Williams & Norgate.
- . (1925). The foundations of mental health. *International Journal of Psychoanalysis*, 7.
- . (1927). An interesting invented “portman-teau” word. *International Journal of Psychoanalysis*, 8, 73–74.
- . (1929). A note on the influence of psychoanalysis upon English education during the last 18 years. *International Journal of Psychoanalysis*, 10, 314–320.
- Lowrie, Walter (Ed.). (1946). *Religion of a scientist: selections from Gustav Theodor Fechner*. New York: Pantheon.
- Luborsky, Lester. (1996). *The symptom-context method: symptoms as opportunities in psychotherapy*. Washington DC: American Psychological Association.
- Luke, Helen M. (2000). *Dark wood to white rose: journey and transformation in Dante’s Divine Comedy*. New York: Parabola Books.
- Lupi, Robert, rep. (1998). Panel: Classics revisited: Freud’s “Mourning and melancholia”. *Journal of the American Psychoanalytic Association*, 46, 867–884.
- Lussier, André. (1983). Les déviations du désir: étude sur le fétichisme. *Revue Française de Psychanalyse*, 47 (1), 19–142.
- Lussier, M. (2000). “Mourning and melancholia”: the genesis of a text and of a concept. *International Journal of Psychoanalysis*, 81, 667–686.
- Lustman, Seymour L. (1968). The economic point of view and defense. *Psychoanalytic Study of the Child*, 23, 189–203.
- Luttenberger, Franz. (1989). *Freud i Sverige*. Stockholm: Carlsson Bokförlag.
- Luzes, Pedro. (1969). Les troubles de la pensée. Réponse aux interventions. 907–912. *Revue Française de Psychanalyse* 33, (5–6), 727–843.
- . (1979). Four recently discovered letters by Freud to a Portuguese correspondent. A contribution to the pre-history of psychoanalysis in Portugal. *International Review of Psycho-Analysis*, 6, 437–440.
- Lyons, Tom Wallace. (1979). *The pelican and after: a novel about emotional disturbance*. Richmond, VA: Pre-scott, Durrell and Co.
- Mâle, Pierre. (1964). *Psychiatrie de l’adolescent*. Paris: Presses Universitaires de France.
- . (1982–1984). *Oeuvres complètes*. (Vol. 1: *La Crise juvénile*. Vol. 2: *De l’enfant à l’adulte*). Paris: Payot.
- Mâle, Pierre, and Favreau, Jean. (1959). Aspects actuels de la clinique et de la thérapeutique des troubles affectifs de l’enfant. *Psychiatrie de l’enfant*, 2 (1), 148–195.
- M’Uzan, Michel de. (1968). Comment on “Psychosomatic Asthma and Acting Out,” by Ph. Wilson. *International Journal of Psychoanalysis*, 49 (2–3), 333–335.

- . (1972). Un cas de masochisme pervers. In *La Sexualité perverse*. Paris: Payot.
- . (1977). *De l'art à la mort*. Paris: Gallimard.
- . (1994). *La bouche de L'Inconscient*. Paris: Gallimard.
- Mâle, Pierre, Doumic-Girard, Alice, Benhamou, Françoise, and Schott, Marie-Claude. (1975). *Psychothérapie du premier-âge. De la théorie à la pratique*. Paris: Presses Universitaires de France.
- Mühlleitner, Elke (1992). *Biographisches Lexikon der Psychoanalyse (Die Mitglieder der Psychologischen Mittwoch-Gesellschaft und der Wiener Psychoanalytischen Vereinigung 1902–1938)*. Tübingen: Diskord.
- Müller, Max. (1982). *Erlebte Psychiatriegeschichte 1920–1960*. Berlin, Springer.
- Müller-Braunschweig, Carl. (1933). Psychoanalyse und Weltanschauung. *Reichswart*, 22 October, 1933.
- . (1948). *Streifzüge durch die Psychoanalyse (Welche Position vertritt der Psychoanalytiker heute)*. Hamburg: Reinbeck.
- . (1955). Zur Menschlichen Grundhaltung, Psychologie und Technik der Psychoanalytischen Therapie. *Psychologische Beiträge*, 2, 56–69.
- Macalpine, Ida, and Hunter, Richard. *Schizophrenia 1677*. London: William Dawson: 1956.
- MacGrath, William J. (1974). *Dionysian and populist politics in Austria*. New Haven; London: Yale University Press.
- Mack Brunswick, Ruth. (1940). The preoedipal phase of the libido development. *Psychoanalytic Quarterly*, 9, 293–319.
- MacLean, George, and Rappen, Ulrich. (1991). *Hermine von Hug-Hellmuth*. New York-London: Routledge.
- Maeder, Alphonse. (1907). Essai d'interprétation de quelques rêves. *Archives de psychologie*, 6, 354–375.
- . (1909). Die Sexualität der Epileptiker. *Jahrbuch für psychoanalytische und psychopathologische Forschungen*, 1, p. 119–154.
- . (1910). Psychologische Untersuchungen an Dementia præcox-Kranken. *Jahrbuch für psychoanalytische und psychopathologische Forschungen*, 2 (1), 185–245.
- . (1910). Zur Entstehung der Symbolik im Traum, in der Dementia præcox, usw. *Zentralblatt für Psychoanalyse*, 1, 383–389.
- . (1912). Über die Funktion des Traumes (mit Berücksichtigung der Tagesträume, des Spieles, usw.). *Jahrbuch für psychoanalytische und psychopathologische Forschungen*, 4.
- . (1957). *Der Psychotherapeut als Partner. Eine appellative Psychotherapie*. Zürich-Stuttgart: Rascher.
- Magnan, Valentin. (1893). *Leçons cliniques sur les maladies mentales: état mental du dipsomane* (2nd ed.). Paris: L. Bataille.
- Mahler, Margaret. (1949). A psychoanalytical evaluation of tics in a psychopathology of children. *Psychoanalytic Study of the Child*, 3, 4, 279–310.
- . (1952). On child psychosis and schizophrenia. *Psychoanalytic Study of the Child*, 7, 286–305.
- . (1958). Problems of identity. *Journal of the American Psychoanalytic Association*, 6, 131–142.
- . (1968). *On human symbiosis or the vicissitudes of individuation*. New York: International Universities Press.
- . (1983). The meaning of developmental research of earliest infancy as related to the study separation-individuation. In *Frontiers of infant psychiatry* (pp. 3–6). New York: Basic Books.
- Mahler, Margaret S., Pine, Fred, and Bergman, Anni. (1975). *The psychological birth of the human infant*. New York: Basic Books.
- Mahony, Patrick. (1980). Toward the understanding of translation in psychoanalysis. *Journal of the American Psychoanalytic Association*, 28, 461–473.
- . (1982). *Freud as a writer*. New York: International Universities Press.
- . (1984). *Cries of the wolf man*. New York: International Universities Press.
- . (1992). *Freud and the Rat Man*. New Haven: Yale University Press.
- . (1993). Freud's oratorical marathon: the shrinking of another myth. *International Journal of Psychoanalysis*, 74, p. 837.
- . (1996). *Freud's Dora: a historical, textual, and psychoanalytic study*. New Haven: Yale University Press.
- Main, Thomas F. (1957). The ailment. *British Journal of Medical Psychology*, 30 (3), 129–145.
- . (1989). *The ailment and other psycho-analytical essays*. London: Free Association Books.
- Major, René. (1978). Dissidence du corps ou "L'État sans tête." In *L'Agonie du jour*. Paris: Aubier-Montaigne.
- . (1991). *Lacan avec Derrida*. Paris: Éditions Menta.
- Makari, George. (1997). Current conceptions of neutrality and abstinence. *Journal of the American Psychoanalytic Association*, 45, 1231–1240.

- Malan, David H. (1963). *A study of brief psychotherapy*. London: Tavistock.
- Maldavsky, David. (1995). A propos du noyau autistique précoce chez l'homme aux loups. *Journal de la Psychanalyse de l'enfant*, 17, 125–142.
- Maldonado, J.L. (1998). Panel: childhood sexual theories and childhood sexuality. *International Journal of Psychoanalysis*, 79, 148–151.
- Malinowski, Bronislaw. (1927). *Sex and repression in savage society*. New York: Harcourt, Brace.
- . (1951). *Sex and repression in savage society*. New York: Humanities Press. (Original work published 1927.)
- . (1962). *The sexual life of savages in northwestern Melanesia: an ethnographic account of courtship, marriage, and family life among the natives of the Trobriand Islands, British New Guinea*. New York: Harcourt, Brace & World. (Original work published 1929.)
- . (1967). *A diary in the strict sense of the term*. London: Routledge & Kegan Paul.
- Mallet, Jean. (1956). Contribution à l'étude des phobies. Rapport à la XVIIIe Conférence des psychanalystes de langues romanes, Paris, 1955. *Revue Française de Psychanalyse*, 20, 1–2, 237–82.
- Mann, Thomas. (1936). Freud and the future. *International Journal of Psychoanalysis*, 37 (1), 106–115.
- . (1941). Freud's position in the history of modern culture. *Psychoanalytic Review*, 28(1), 92–116.
- . (1996). *Être écrivain allemand à notre époque*. Paris: Gallimard.
- Mannoni, Maud. (1970). *Le psychiatre, son "fou" et la psychanalyse*. Paris: Seuil.
- . (1970). *The child, his "illness,"* ——. (1972). *The backward child and his mother: a psychoanalytic study*. (A. M. Sheridan Smith, Trans.). New York: Pantheon Books. (Original work published 1964)
- . (1979). *La théorie comme fiction: Freud, Groddeck, Winnicott, Lacan*. Paris: Le Seuil.
- . (1987). *The child, his "illness,"* ——. (1995). *Les mots ont un poids, ils sont vivants*. Paris: Denoël.
- . (1998). *Elles ne savent pas ce qu'elles disent*. Paris: Denoël.
- . (1999). *Separation and creativity: refinding the lost language of childhood*. New York: Other Press.
- Mannoni, Octave. (1951). *Lettre personnelles à monsieur le Directeur*. Paris, Denoël.
- . (1956). *Prospero and Caliban: The Psychology of Colonization*. London, Methuen.
- . (1969). *Clefs pour l'imaginaire*. Paris, Le Seuil.
- . (1971). *Freud* (Renaud Bruce, Trans.). New York: Pantheon. (Original work published 1968)
- . (1985). Obsession et névrose obsessionnelle. In *Encyclopaedia Universalis*, 13, 308–10.
- . (1990). *Nous nous quittons. C'est là ma route*. Paris, Denoël.
- Manson, William C. (1988). *The psychodynamics of culture: Abram Kardiner and neo-Freudian anthropology*. New York, Greenwood Press.
- Marbeau-Cleirens, Béatrice. (1987). *Le sexe de la mère et les divergences des théories psychanalytiques*. Paris: Presses Universitaires de France.
- Marcé, Louis-Victor. (1958). *Traité de la folie des femmes enceintes, des nouvelles accouchées et des nourrices et considérations médico-légales qui se rattachent à ce sujet*. Paris: Bailliére.
- Marchais, Pierre. (1968). *Les processus névrotiques: contribution à l'étude psychopathologique des névroses*. Paris: L'Expansion.
- Marcinowski, Johannes. (1904). *Im Kampf um gesunde Nerven. Ein Wegweiser zum Verständnis und zur Heilung nervöser Zustände*. Berlin: O. Salle.
- . (1905). *Nervosität und Weltanschauung. Studien zur seelischen Behandlung Nervöser nebst einer kurzen Theorie vom Wollen und Können*. Berlin: O. Salle.
- . (1916). *Neue Bahnen zur Heilung nervöser Zustände. Ein Stück Lebenskunst für alle*. Berlin: O. Salle.
- Marcondes, Durval. (1951). *A Medicina e a Psicologia*. São Paulo: Martins.
- Marcus, Eric. (1992). *Psychosis and near psychosis: Ego function, symbolic structure, treatment*. New York: Springer-Verlag.
- Marcuse, Herbert. (1941). *Reason and revolution: Hegel and the rise of social theory*. New York: Oxford University Press.
- . (1955). *Eros and civilization: A philosophical inquiry into Freud*. Boston: Beacon Press.
- . (1958). *Soviet Marxism: A critical analysis*. New York: Columbia University Press.
- . (1964). *One dimensional man: studies in the ideology of advanced industrial society*. Boston: Beacon Press.
- . (1968). *An essay on liberation*. Boston: Beacon Press.
- . (1973). *Counterrevolution and revolt*. Boston: Beacon Press.
- . (1987). *Hegel's ontology and the theory of historicity* (Seyla Benhabib, Trans.). Cambridge, MA: MIT Press.

- Marette (Dolto), Françoise. (1940). *Psychanalyse et Pédiatrie. Le complexe de castration. Étude générale. Cas cliniques*. Préf. Édouard Pichon, Paris: Éd. A. Legrand; Dolto, Françoise. *Psychanalyse et Pédiatrie*. Paris: Le Seuil, coll. "Points" 1971.
- Mariátegui, Javier. (1981). *Hermilio Valdizán. El proyecto de una psiquiatría peruana*. Lima: Librería Minerva.
- . (1989). *Freud y el psicoanálisis*. Lima: University Cayetano Heredia.
- Mariátegui, Javier, and León, Ramón. (1987). *La Revista de psiquiatría y disciplinas conexas (1918–1924)*. Lima: Instituto de Salud Mental y Universidad Peruana Cayetano Heredia, 1–41.
- Marineau, René. (1989). *J.-L. Moreno et la Troisième Révolution psychanalytique*. Paris, Metailié.
- Marinov, Vladimir. (1990). *Figures du crime chez Dostoïewski*. Paris: Presses Universitaires de France.
- Markson, Elliott. (1993). Depression and moral masochism. *International Journal of Psychoanalysis*, 74, 931–940.
- Marti, Jean. (1976). La psychanalyse en Russie et en Union Soviétique. *Critique*, 32, 199–236.
- Martin, Jean-Luc. (1984). La question du langage chez Freud, de 1891 à 1901. *L'évolution psychiatrique*, 2, 451–486.
- Martinet, Andre. (1964). *Elements of General Linguistics*. (Elizabeth Palmer, Trans.). Chicago: University of Chicago Press. (Original work published 1960)
- Martins, Cyro. (1964). *Do mito à verdade científica: estudos psicanalíticos*. Rio de Janeiro, Brazil: Globo.
- . (1968). Regression in the analytic process: transferential snapshot. *Revista brasileira de psicanálise*, 2, 191–197.
- . (1969). Sex identity disorders in Diadorim, a figure in the novel *Grande sertão: veredas*. *Revista brasileira de psicanálise*, 3, 406–415.
- . (1973). Perspectivas do humanismo psicanalítico. Pôrto Alegre, Brazil: Sulina.
- . (1976). Contribution to the study of the history of psychoanalysis in Brazil. *Revista brasileira de psicanálise*, 10, 289–293.
- . (1994). Summary of history and relations with I.P.A. *Revista brasileira de psicanálise*, 28, 419–424.
- Martins, Cyro, and Slavutzky, Abrão. (1990). *Para início de conversa*. Pôrto Alegre, Brazil: Movimento.
- Marty, Pierre. (1958). The allergic object relationship. *International Journal of Psychoanalysis*, 39, 98–103.
- . (1963). *La psychosomatique de l'adulte*. Paris: Presses Universitaires de France.
- . (1966). La dépression essentielle. *Revue française de psychanalyse*, 30, 5–6.
- . (1967). Régression et instinct de mort: Hypothèses à propos de l'observation psychosomatique. *Revue française de psychanalyse*, 30, (5–6), pp. 1113–1126.
- . (1976). *Les mouvements individuels de vie et de mort* (Vol. 1, *Essai d'économie psychosomatique*). Paris: Payot.
- . (1980). *Les mouvements individuels de vie et de mort* (Vol. 2, *L'Ordre psychosomatique*). Paris: Payot.
- . (1990). *La psychosomatique de l'adulte*. Paris: Presses Universitaires de France.
- . (1991). *Mentalisation et psychosomatique*. Paris: Synthélabo.
- Marty, Pierre, and M'Uzan, Michel de. (1962). La pensée opératoire. Intervention sur le rapport de M. Fain et Ch. David: Aspects fonctionnels de la vie onirique. XXIIIe Congrès des psychanalystes de langues romanes, Barcelone, 1962, *Revue française de psychanalyse*, 27, special issue, 345–356.
- Marty, Pierre, et al. (1968). Le cas Dora et le point de vue psychosomatique. *Revue française de psychanalyse*, 32, 4.
- Marty, Pierre, M'Uzan, Michel de, and David, Christian. (1963). *L'Investigation psychosomatique*. Paris: Presses Universitaires de France.
- Masson, Jeffrey Moussaieff. (1984). *The assault on truth*. New York: Farrar, Straus & Giroux.
- . (1985). *The complete letters of Sigmund Freud to Wilhelm Fliess 1887–1904*. London: Belknap.
- Matte-Blanco, Ignacio. (1975). *The unconscious as infinite sets: An essay in bi-logic*. London: Duckworth.
- . (1988). *Thinking, feeling and being*. (Eric Rayner and David Tuckett, Trans.). London: Routledge.
- Mauco, Georges. (1932). *Les étrangers en France: Leur rôle dans la vie économique*. Paris: Armand Colin.
- . (1975). *L'évolution de la psychopédagogie*. Toulouse, France: Pragma-Privat.
- . (1977). *Les étrangers en France et le problème du racisme*. Paris: La pensée universelle.
- . (1982). *Vécu 1899–1982*. Paris: Émile Paul.
- Maurey, Gilbert. (1995). *Le Rêve-éveillé en psychanalyse. De l'imaginaire à l'Inconscient*. Paris: E. S. F.
- Mauss, Marcel. (1990). *The gift: The form and reason for exchange in archaic societies* (W. D. Halls, Trans.). New York: W.W. Norton. (Original work published 1923)

- Maximov, Valeri. (1988). Histoire de la psychanalyse: la psychanalyse russe. *L'Âne*, 10, 3–5.
- May, Rollo; Angel, Ernest, and Ellenberger, Henri F. (1958). *Existence: a new dimension in psychiatry and psychology*. New York: Basic Books.
- Mayer, Elizabeth Lloyd. (1995). The phallic castration complex and primary femininity: Paired developmental lines toward female gender identity. *Journal of the American Psychoanalytic Association*, 43, 17–38.
- Maze, John R. (1993). The complementarity of object-relations and instinct theory. *International Journal of Psychoanalysis*, 74, 459–470.
- Mazet, Philippe. (1997). Quels sont les particularités cliniques des troubles dépressifs chez le nourrisson? In: *Les troubles dépressifs chez l'enfant: reconnaître, soigner, prévenir, devenir* (pp. 25–32). Paris: Frison-Roche.
- McDougall, Joyce. (1972). L'anti-analysant en analyse. *Revue Française de Psychanalyse*, 36, 167–206.
- . (1974). The psyche-soma and the psychoanalytic process. *International Journal of Psychoanalysis*, 1, 437–460.
- . (1982). The narcissistic economy and its relation to primitive sexuality. *Contemporary Psychoanalysis*, 18, 373–396.
- . (1989). *Theaters of the body: a psychoanalytic approach to psychosomatic illness*. New York: Norton.
- . (1992). *Plea for a measure of abnormality*. New York: Brunner/Mazel. (Original work published 1978)
- . (1995). *The many faces of Eros: a psychoanalytic exploration of human sexuality*. New York: W.W. Norton.
- McDougall, Joyce, and Lebovici, Serge. (1960). *Un cas de psychose infantile*. Paris: Presses Universitaires de France.
- McGuire William. (1974). *The Freud-Jung letters: The correspondence between Sigmund Freud and C.G. Jung*. Princeton, NJ: Princeton University Press.
- . (1989). *C.G. Jung, Analytical psychology, Notes of the seminar given in 1925*. Princeton: Princeton University Press.
- McNutt, Edith R. rep. (1992). Panel: Psychoanalysis and psychotherapy: indications, contraindications. *Journal of the American Psychoanalytic Association*, 40, 223–232.
- McWilliams, Nancy. (1984). The psychology of the altruist. *Psychoanalytic Psychology*, 1, 193–214.
- Mead, Margaret. (1928). *Coming of age in Samoa*. New York: William Morrow.
- . (1930). *Growing up in New Guinea*. New York: William Morrow.
- . (1935). *Sex and temperament in three primitive societies*. New York: William Morrow.
- . (1949). *Male and female*. New York: William Morrow.
- . (1963). Totem and taboo reconsidered with respect. *Bulletin of the Menninger Clinic*, 27, 185–199.
- . (1972). *Blackberry winter: My earlier years*. New York: William Morrow.
- . (1978). The evocation of psychologically relevant responses in ethnological field work. In George D. Spindler (Ed.), *The making of psychological anthropology* (pp. 88–139). Berkeley: University of California Press.
- Meerwein, Fritz. (1979). Reflexionen zur Geschichte der Schweizerischen Gesellschaft für Psychoanalyse in der deutschen Schweiz. *Bulletin de la Société suisse de psychanalyse*, 9, 25–40.
- Meisel, Perry, and Kendrick, Walter. (1986). *Bloomsbury-Freud: the letters of James and Alix Strachey, 1924–1925*. London: Chatto and Windus.
- Meissner, William W. (1970). Notes on identification I. Origins in Freud. *Psychoanalytic Quarterly*, 39, 563.
- . (1986). *Psychotherapy and the paranoid process*. Northvale, NJ: Jason Aronson.
- . (1995). The economic principle in psychoanalysis. *Psychoanalysis and Contemporary Thought*, 18, 197–292.
- . (1996). The self-as-object in psychoanalysis. *Psychoanalysis and Contemporary Thought*, 19, 425–460.
- . (1997). The self and the body: The body self and the body image. *Psychoanalysis and Contemporary Thought*, 20, 419–448.
- . (1998). The self and the body: III. The body image in clinical perspective. *Psychoanalysis and Contemporary Thought*, 21, 113–146.
- . (1999). Dynamic principle in psychoanalysis. *Psychoanalysis and Contemporary Thought*, 22, 2–84.
- . (2001). Psychic reality in the psychoanalytic process. *Journal of the American Psychoanalytic Association*, 49, 855–890.
- Mellor-Picaut, Sophie. (1977). Le travail de la création dans “L'autoanalyse de Freud et la découverte de la psychanalyse” par Didier Anzieu. *Psychanalyse à l'université*. 2 (8), 707–724.
- . (1979). La sublimation ruse de la civilisation. *Psychanalyse à l'Université*, 4.
- . (1980). La vision et l'énigme. *Topique*, 25.

- Meltzer, Donald. (1966). The relationship of anal masturbation to projective identification. *International Journal of Psychoanalysis*, 47, 335–342.
- . (1967). *The psycho-analytical process*. London: Heinemann Medical.
- . (1973). *Sexual states of mind*. Perthshire, Scotland: Clunie Press.
- . (1975). Adhesive identification. *Contemporary Psycho-Analysis*, 11, 289–310.
- . (1986). The proto-mental apparatus and soma-psychotic phenomena. In *Studies in extended metapsychology*. London: Clunie Press.
- . (1988). Le Conflit esthétique: son rôle dans le processus de développement psychique. *Psychanalyse à l'Université*, 13 (49), 37–57.
- . (1990). *Sexual states of mind*. Perthshire, Scotland: Clunie Press. (Original work published 1973)
- . (1992). *The claustrum. An investigation of claustrophobic phenomena*. London: Karnac Books.
- . (1994). Does Money-Kyrle's concept of misconception have any unique descriptive power? In *Sincerity and other works* (pp. 495–513). London: Karnac Books. (Original work published 1982)
- Meltzer, Donald, and Williams, Meg Harris. (1988). *The apprehension of beauty*. Perth: Clunie Press.
- Meltzer, Donald, et al. (1991). *Explorations in Autism*. Perthshire, Scotland: Clunie Press. (Original work published 1975)
- Menahem, Ruth. (1986). Urverdrängung primaire, originaire, originel. *Revue française de Psychanalyse*, 50, 1.
- Menaker, Esther. (1982). *Otto Rank: A rediscovered legacy*. New York: Columbia University Press.
- Mendel, Gérard. (1968). *La révolte contre le père*. Paris: Payot.
- . (1992). René Held toujours vivant. *Raison présente*, 102, 120.
- Meng, Heinrich. (1934). *Strafen und Erziehen*. Berne: Hans Huber.
- . (1958). *Psychohygienische Vorlesungen. Eine Einführung in Theorie und Praxis des seelischen Gesundheitsschutzes*. Basel-Stuttgart: Benno Schwabe.
- . (1971). *Leben als Begegnung*. Stuttgart: Hippokrates.
- Menninger, Karl A. (1930). *The human mind*. New York: Alfred A. Knopf.
- . (1938). *Man against himself*. New York: Harcourt, Brace & World.
- . (1942). *Love against hate*. New York: Harcourt, Brace & World.
- . (1963). *The vital balance: The life process in mental health and illness*. New York: The Viking Press.
- . (1968). *The crime of punishment*. New York: The Viking Press.
- Menninger, Walter W. (1988). Introduction: the crises of adolescence and aging. *Bulletin of the Menninger Clinic*, 52, 190–197.
- Menzerath, Paul. (1912). Contribution à la psychanalyse. *Archives de psychologie*, 12, 372–389.
- Meringer, Rudolf, and Mayer, Carl. (1895). *Versprechen und Verlesen: eine psychologisch-linguistische Studie*. Stuttgart: G.J. Göschen.
- Merleau-Ponty, Maurice. (1962). *Phenomenology of perception* (Colin Smith, Trans.). London: Routledge. (Original work published 1945)
- . (1963). *The structure of behavior* (Alden L. Fisher, Trans.). Boston: Beacon Press. (Original work published 1942)
- . (1968). *The visible and the invisible* (Alphonso Lingis, Trans.). Evanston, IL: Northwestern University Press. (Original work published 1964)
- . (1973). *Adventures of the dialectic* (Joseph Bien, Trans.). Evanston, IL: Northwestern University Press. (Original work published 1955)
- Mesmer, Anton (1779). *Mémoire sur la découverte du magnétisme animal*. Geneva: P.F. Didot le jeune.
- Metz, Christian. (1979). *The imaginary signifier: Psychoanalysis and the cinema* (C. Britton et al., Trans.). Bloomington: Indiana University Press.
- . (1982). *The imaginary signifier. Psychoanalysis and the cinema*. Bloomington: Indiana University Press.
- Meyer, Adolf. (1950–1952). *Collected papers of Adolf Meyer* (4 vols.). Baltimore, MD: Johns Hopkins Press.
- . (1957). *Psychobiology: a science of man*. Springfield, IL: Thomas.
- Meyerson, Ignace. (1948). Les fonctions psychologiques et les œuvres, thèse pour le doctorat ès-lettres présentée à la faculté des lettres de Paris, 1947. Paris: Vrin.
- . (1987). *Écrits 1920–1983. Pour une psychologie historique*. Paris: Presses Universitaires de France.
- Meynert, Theodor. (1883). L'Aménia, ou confusion. C. Levy-Friesacher (Ed.), *Meynert-Freud "L'amentia"*, Paris: Presses Universitaires de France. (Original work published 1890)
- Micale, Mark S. (1993). Henri Ellenberger and the origin of European psychiatric historiography. In Henri

- Ellenberger, *Beyond the unconscious: essays of Henry F. Ellenberger in the history of psychiatry*. Princeton, NJ: Princeton University Press 1993.
- Micale, Mark S. (Ed.). (1993). *Beyond the unconscious. Essays of Henri F. Ellenberger in the History of Psychiatry*. Princeton, NJ: Princeton University Press.
- Michaux, Didier (Ed.). (1995). *La transe et l'hypnose*. Paris: Imago.
- Michel, André. (1987). Léon Bloy et Paul Jury. *Bulletin Sté ét. bloyennes*, 10–11, Oct. 1990, 12–13, April 1993.
- . (1992). *Décroire, fondement d'un rationalisme psychanalytique (entretiens avec Paul Jury)*. . Gentilly: Albin Michel.
- Miermont, Jacques. (1985). Mythes et modèles scientifiques en psychothérapie individuelle et en thérapie familiale. *Actualités psychiatriques*, 9.
- Mijolla, Alain de. (1975). Fantômes d'identification: Jakob, Freud et Goethe. *Études freudiennes*, 9–10, 167–210.
- . (1979). “Mein Onkel Josef” à la une! *Études freudiennes*, 15–16, 183–192.
- . (1981). La désertion du capitaine Rimbaud. *Les visiteurs du moi, fantômes d'identifications*. Paris: Les Belles Lettres. (Original work published 1975)
- . (1982). Aux origines de la pratique psychanalytique. In R. Jaccard (Ed.), *Histoire de la psychanalyse* (v. I, pp. 11–43). Paris: Hachette.
- . (1982). En guise d'ouverture. . . . In Cain, Jacques, et al. (eds.). *Psychanalyse et Musique*. Paris: Les Belles Lettres.
- . (1982). La psychanalyse en France, 1893–1965. In Roland Jaccard (Ed.), *Histoire de la psychanalyse* (Vol. 2, pp. 9–105). Paris: Hachette.
- . (1984). Quelques avatars de la psychanalyse en France. Lecture du *Disque Vert* (June 1924). *L'Évolution psychiatrique*, 49, 3, 773–795.
- . (1985). Pulsions d'investigation, fantômes d'identification et roman familial. *Topique*, 34, 33–59.
- . (1986). *Les Visiteurs du Moi, fantômes d'identification, Confluents psychanalytiques* (2nd ed.). Paris: Les Belles Lettres. (Original work published 1981)
- . (1987). De la pratique psychanalytique de Freud à la nôtre. *Études Freudiennes*, 30, 17–37.
- . (1987). Unconscious identification fantasies and family prehistory. *International Journal of Psychoanalysis*, 68, 397–403.
- . (1988). Psychoanalysis and psychoanalysts in France between 1939 and 1945. *International Forum for Psychoanalysis*, 12, 136–156.
- . (1988). Les lettres de Jean-Martin Charcot à Sigmund Freud, 1886–1893. Le crépuscule d'un dieu. *Revue française de psychanalyse*, 52 (3), 703–726.
- . (1988). Quelques aperçus sur le rôle de la princesse Marie Bonaparte dans la création de la Société psychanalytique de Paris. *Revue française de psychanalyse*, 52 (5), 1197–1214.
- . (1989). A sale in Vienna. *Journal de l'association internationale d'histoire de la psychanalyse*, 8.
- . (1989). Images of Freud from his correspondence. *International Forum of Psychoanalysis*, 5, 87–110.
- . (1991). L'édition en français des “Œuvres” de Freud avant 1940. Autour de quelques documents nouveaux. *Revue internationale d'histoire de la psychanalyse*, 4, 209–270.
- . (1991). Les congrès des psychanalystes de langue française des pays romans: Quelques éléments d'histoire. *Revue française de psychanalyse*, 55 (1), 7–36.
- . (1992). France, 1893–1965. In Peter Kutter (Ed.), *Psychoanalysis international: a guide to psychoanalysis throughout the world*, Vol. 1: Europe (pp. 66–113). Stuttgart, Germany: Frommann-Holzboog.
- . (1996). La scission de la Société psychanalytique de Paris en 1953: quelques notes pour un rappel historique. *Cliniques méditerranéennes*, 49–50, 9–30.
- . (1996). Un adolescent bien tranquille. Sig(is)-mund Freud, 1870–1876. *Cahiers du Collège international de l'Adolescence*, 1, p. 231–267.
- . (1996). Images of Freud: From his correspondence. *International Forum for Psychoanalysis*, 5, 87–110.
- . (1998). Freud, biography, his autobiography and his biographers. *Psychoanalysis and History*, 1 (1), 4–27.
- . (1998). Le “conflit thérapeutique” et la “neutralité.” In G. Diatkine and J. Schaeffer (Eds.), *Psychothérapies psychanalytiques* (pp. 110–119). Paris: Presses Universitaires de France.
- . (1999). Freud and the psychoanalytic situation on the screen. In J. Bergstrom (Ed.), *Endless night. Cinema and psychoanalysis: Parallel histories* (p. 188–199). Los Angeles and London: University of California Press. (Original work published 1994)
- . Splits in the French psychoanalytic movement between 1953 and 1964. In R. Steiner and J. Johns (Eds.). *Within Time and Beyond Time* (pp. 1–24). London: Karnac.
- . (2004). *Préhistoires de famille*. Paris: Presses Universitaires de France.



- Mijolla, Alain de (ed.). (1993). *À la musique*. Paris: Les Belles Lettres.
- Mijolla, Alain de, and Mijolla-Mellor, Sophie de (Eds.). (1995). *Psychanalyse*. Paris: Presses Universitaires de France.
- Mijolla, Alain de, and Shentoub, Salem A. (1973). *Pour une psychanalyse de l'alcoolisme*. Paris: Payot.
- Mijolla-Mellor, Sophie de. (1985). La trame phobique de l'ennui. *Nouvelle revue de psychanalyse*, 32, 173–184.
- . (1985). Vérité ou fantasme de vérité. *Métapsychologie et Philosophie*. Paris: Les Belles Lettres.
- . (1987). Le phénomène passionnel. *Dialogue*, 96.
- . (1988). Survivre à so passé. In *L'autobiographie*. Paris: Les Belles Lettres.
- . (1990). Autobiographie de la psychanalyse. *Le Coq-Héron*, 118, 6–14.
- . (1992). *Le plaisir de pensée*. Paris: Presses Universitaires de France.
- . (1993). Le “bon droit” du criminel. *Topique*, 52, 141–161.
- . (1995). *Meurtre familial. Approche psychanalytique d'Agatha Christie*. Paris: Dunod.
- . (1995). Potentialité des scissions dans la théorie psychanalytique elle-même. *Topique*, 57, 291–306.
- . (1996). Aliénator, ou les enjeux théoriques de la troisième scission dans le mouvement psychanalytique en France. *Cliniques méditerranéennes*, 49–50, 79–93.
- . (1996). Le meurtre comme théorie sexuelle infantile. *Topique*, 59, 15–29.
- . (1998). *Penser la psychose. Une lecture de l'œuvre de Piera Aulagnier*. Paris: Dunod.
- Mikhalevitch, Alexandre. (1991). L'âge d'argent de la psychanalyse russe. Les premières traductions des œuvres de Freud en Russie prérévolutionnaire, 1904–1914. *Revue internationale d'histoire de la psychanalyse*, 4, 399–406.
- Mill, John Stuart. (2001). *Utilitarianism*. (George Schel, Ed.). Indianapolis, IN: Hackett Publications.
- Millar, David. (2001). A psychoanalytic view of biblical myth. *International Journal of Psychoanalysis*, 82, 965–980.
- Millaud, Frédéric (Ed.). (2002). *Le Passage à l'acte: aspects cliniques et psychodynamiques*. Paris: Masson.
- Miller, Gérard. (1990). Préface. In Bullitt, William C., and Freud, Sigmund, *Le président T. W. Wilson*. Paris: Payot, “Petite Bibliothèque.”
- Miller, George A., Galanter, E., and Karl H. Pribram. (1960). *Plans and the structure of behavior*, New York: Holt, Rinehart & Winston.
- Miller, Jacques-Alain. (1984). Editorial. *Ornicar?* 28.
- . (1985). *Entretien sur le séminaire avec François Ansermet*. Paris: Navarin.
- Miller, Laurence (1991). On aphasia at 100: the neuropsychodynamic legacy of Freud. *Psychoanalytic Review*, 78, 365–378.
- Miller, Martin. (1998). *Freud and the Bolsheviks: Psychoanalysis in imperial Russia and the Soviet Union*. New Haven, CT: Yale University Press.
- Miller, P.; Rose, N., and Pines, Malcolm. (1994). On therapeutic authority: psychoanalytic expertise under advanced liberalism. *History of the Human Science*, 7 (3), 9–64.
- Millet, L.; Pon, J., and Millet-Bartoli, F. (1994). *La crise du milieu de la vie*. Paris: Masson.
- Milner, Jean-Claude. (1978). *L'amour de la langue*. Paris: Seuil.
- . (1995). *L'Œuvre Claire*. Paris: Seuil.
- Milner, Marion. (1969). *The hands of the living god*. New York: International Universities Press.
- . (1987). *The suppressed madness of sane men. Forty-four years of exploring psychoanalysis*. London, New York: Tavistock Publications.
- . (1991). *On est prié de fermer les yeux. Le regard interdit*. Paris: Gallimard.
- Milrod, David. (1971). *Oral history interview with Edith Jacobson*. New York : A.A. Brill Library, New York Psychoanalytic Institute
- . (2002). The superego: its formation, structure, and functioning. *Psychoanalytic Study of the Child*, 57, 131–150.
- Minkowska, Françoise. (1956). *Le Rorschach. À la recherche du monde des formes*. Paris: Desclée de Brouwer.
- Minkowski, Eugène. (1923). Étude psychologique et analyse phénoménologique d'un cas de mélancolie schizophrénique. *Journal de psychologie normale et pathologique*, 20, 543–558.
- . (1927). *La Schizophrénie*. Paris: Payot.
- . (1933). *Le Temps vécu. Études phénoménologiques et psychopathologiques*. Paris: Payot.
- . (1999). *Traité de psychopathologie*. Paris: Le Plessis-Robinson. (Original work published 1966)
- Minkowski, Mieczyslaw. (1928). A supplement to Freud's history of an infantile neurosis. *International Journal of Psychoanalysis*, 9, 439–76.

- . (1969). Louis Rodolphe Brun, 1885–1969. *Schweizer Archiv. Neurol. Neurochir. Psychiatr.*, 106, 330–334.
- Mintz, I.L. (1975). Evolution of Otto Rank's theory of the birth trauma. *International Review of Psychoanalysis*, 2, 245–246.
- Misès, Roger. (1990). *Les pathologies limites de l'enfance*. Paris: Presses Universitaires de France.
- Misès, Roger, and Moniot, Marc. (1970). Les psychoses de l'enfant. In *Encyclopédie médico-chirurgicale*, vol. *Psychiatrie*. Paris: E.M.-C.
- Missenard, André. (1987). L'enveloppe du rêve et le fantasme de psyché commune. In Anzieu, Didier, Houzel, Didier, et al., *Les enveloppes psychiques*. Paris: Dunod.
- Mitchell, Juliet. (1974). *Psychoanalysis and feminism*. Harmondsworth: Penguin Books.
- Mitchell, Stephen. (1998). Aggression and the endangered self. *Psychoanalytical Inquiry*, 18, 21–30.
- Mitrani, J. (1993). "Unmentalized" experience in the etiology and treatment of psychosomatic asthma. *Contemporary Psychoanalysis*, 29 (2), 314–342.
- Mitscherlich, Alexander. (1963). *Society without the father: A contribution to social psychology*. Trans. Eric Mosbacher. New York: Schocken Books, 1970.
- . (1965). *Die Unwirtlichkeit unserer Städte*. Frankfurt am Main: Anstiftung zum Unfrieden.
- . (1974). *Society without the father: a contribution to social psychology* (Erick Mosbacher, Trans.). New York: J. Aronson. (Original work published 1964)
- . (1980). *Ein Leben für die Psychoanalyse. Anmerkungen zu meiner Zeit*. Frankfurt: Suhrkamp.
- . (1983). *Gesammelte Schriften*. Frankfurt: Suhrkamp, 1983.
- . (1992). *Society without the father: A contribution to social psychology*. New York: Harper. (Original work published 1963)
- Mitscherlich, Alexander, and Mielke, Fred. (1949). *Doctors of infamy: The story of the Nazi medical crimes*. New York: H. Schuman.
- Mitscherlich, Alexander, and Mitscherlich, Margarete. (1975). *The inability to mourn: Principles of collective behavior*. New York: Grove Press.
- Modell, Arnold H. (1988). Treatment, psychic structure: resolution of the transference. *Journal of the American Psychoanalytic Association*, 36 (S), 225–240.
- . (2000). Are mental functions hierarchical? *Annual of Psychoanalysis*, 28, 127–136.
- Moellenhoff, Fritz. (1966). Hanns Sachs, 1881–1947: the creative unconscious. In *Psychoanalytic pioneers* (F. Alexander, S. Eisenstein, and M. Grotjahn, Eds.). New York and London: Basic Books.
- Moll, Jeanne. (1989). *La Pédagogie psychanalytique. Origine et histoire*. Paris: Dunod.
- Mom, Jorge M. (1956). Algunas consideraciones sobre el concepto de distancia en las fobias. *Revista de psicoanálisis de la Asociación psicoanalítica argentina*, 13 (4), 430–435.
- . (1957). Algunas consideraciones sobre la interpretación en las fobias. *Revista de psicoanálisis de la Asociación psicoanalítica argentina*, 14 (1–2), 63–71.
- . (1960). Aspectos teóricos y técnicos en las fobias et en las modalidades fóbicas. *Revista de psicoanálisis de la Asociación psicoanalítica argentina*, 17 (2), 190–218.
- . (1962). Consideraciones sobre le concepto de fobia en relación con algunos aspectos de la obra de Melanie Klein. *Revista de psicoanálisis de la Asociación psicoanalítica argentina*, 19, (1–2), 26–33.
- Mom, Jorge M., et al. (1982). *Asociación psicoanalítica argentina 1942–1982*. Buenos Aires: A.P.A.
- Mom, Jorge M., Foks, Gilda, and Suárez, Juan Carlos. (1982). *Asociación psicoanalítica argentina 1942–1982*. Buenos Aires: APA
- Money, John (Ed.). (1965). *Sex research: new developments*. New York: Holt, Rinehart and Winston.
- Money-Kyrle, Roger E. (1930). *The meaning of sacrifice*. London: L. & V. Woolf and the Institute of Psycho-Analysis.
- . (1937). The development of war. *British Journal of Medical Psychology*, 17, 219–236.
- . (1951). *Psychoanalysis and politics: a contribution to the psychology of politics and morals*. London: G. Duckworth.
- . (1956). Normal countertransference and some of its deviations., *International Journal of Psychoanalysis*, 37, 360–366.
- . (1961). *Man's picture of his world*. New York: International Universities Press.
- . (1978). *The collected papers of Roger Money-Kyrle*. Perthshire, UK: Clunie Press.
- . (1978). A psychological analysis of the causes of war. In *The collected papers of Roger Money-Kyrle*. Perthshire, UK: Clunie Press. (Originally published 1934)
- Montrelay, Michèle. (1977). *L'ombre et le nom. Sur la féminité*. Paris: Editions de Minuit.
- . (1978). Inquiry into femininity. *M/F*, 1, 83–102.

- Moreau Ricaud, Michelle (2000). *Michael Balint: Le renouveau de l'école de Budapest*. Toulouse, France: Érès.
- Moreau, Daniel. (1980). Édouard Pichon, médecin, psychanalyste, linguiste: vie et oeuvre: contribution à l'histoire du mouvement psychanalytique français. S.l., s.n.
- Moreno, Jacob Lévy. (1934). *Who Shall Survive? Foundations of Sociometry, Group Psychotherapy and Sociodrama*. New York, Beacon House.
- . (1946–1969). *Psychodrama* (3 vols.). New York: Beacon House.
- . (1947). *The theater of spontaneity: An introduction to psychodrama*. New York, Beacon House.
- . (1959). *Gruppenpsychotherapie und Psychodrama, Einleitung in die Theorie und Praxis*. Stuttgart, G. Thieme.
- . (1966). *The international handbook of group psychotherapy*. New York: Philosophical Library.
- Morgenstern, Sophie. (1927). Un cas de mutisme psychogène, *Revue française de psychanalyse*, 1 (3), 492–504.
- . (1930). La psychanalyse infantile et son rôle dans l'hygiène mentale, *Revue française de psychanalyse*, 4 (1), 136–162.
- . (1933). Quelques aperçus sur l'expression du sentiment de culpabilité dans les rêves des enfants, *Revue française de psychanalyse*, 6 (2), 155–174.
- . (1937). *Psychanalyse infantile (symbolisme et valeur clinique des créations imaginatives chez l'enfant)*. Paris: Denoël.
- . (1939). Le symbolisme et la valeur psychanalytique des dessins infantiles, *Revue française de psychanalyse*, 11 (1), 39–48.
- Morgenthaler, Fritz. (1978). *Technik zur Dialektik der Psychoanalytischen Praxis*.
- . (1984). *Homosexualität, Heterosexualität, Perversion*. Frankfurt am Main: Qumran.
- . (1986). *Der Traum, Fragmente zur Theorie und Technik der Traumdeutung* (P. Parin, Ed.). Frankfurt am Main: Campus.
- Morichau-Beauchant, Pierre. (1910). L'inconscient et la défense de la vie. *L'Effort*, 1.
- . (1911). Le rapport affectif dans la cure des psycho-névroses. *Gazette hôpitaux*, 84 (14), 1845–1849.
- . (1912). Homosexualität und Paranoia. *Zentralblatt für Psychoanalyse*, 2, 174–176.
- . (1912). L'instinct sexuel avant la puberté. *Journal médical français*, 6 (5), 375–382.
- . (1912). Les troubles de l'instinct sexuel chez les épileptiques. *Journal médical français*, 6 (4), 155–161.
- Morichau-Beauchant, René. (1910). L'inconscient et la défense de la vie. *L'effort*, 1.
- . (1911). Le rapport affectif dans la cure des psycho-névroses. *Gazette hôpitaux*, 84 (14), 1845–1849.
- Moro, Marie-Rose. (1994). *Parents en exil. Psychopathologie et migration*. Paris: Presses Universitaires de France.
- . (1998). *Psychothérapie transculturelle des enfants de migrants*. Paris: Dunod.
- . (1998). L'enfant en situation de guerre ou de catastrophe, réflexion préliminaire et Soutien psychologique auprès des ex-détenus bosniaques musulmans et de leur famille, Médecins sans frontières. *Medical News*, 7, 2.
- Morrison, K. (1999). Agency, ontology, & analysis: R. Schafer's hermeneutic conflict. *Psychoanalysis and Contemporary Thought*, 22, 203–220.
- Morselli, Enrico Agostino. (1926). *La Psicoanalisi, Studii ed appunti critici, vol. I: La Dottrina, vol. II: La Praticità*. Milano: Fratelli Bocca.
- Moscovici, Marie. (1986). Préface. In Sigmund Freud, *L'Homme Moïse et la Religion monothéiste. Trois Essais* (p. 15–53). Paris: Gallimard.
- Moscovici, Serge. (1981). *The age of the crowd: a historical treatise on mass psychology*. (J.C. Whitehouse, Trans.). Cambridge and New York: Cambridge University Press
- Moser, Alexander. (1992). Psychoanalysis in Switzerland. In Paul Kutter (Ed.), *Psychoanalysis international, a guide to psychoanalysis throughout the world* (Vol. 1, Europe). Stuttgart-Bad Cannstatt: Frommann-Holzboog.
- Moses, Raphael. (1998). Psychoanalyse in Israel. *Psychoanalytische Blätter*, 9.
- Moses-Hrushovski, Rina. (1994). *Deployment: hiding behind power struggles as a character defense*. Northvale, NJ: Jason Aronson.
- Moulton, Ruth. (1986). Clara Thompson: unassuming leader. In L. Dickstein, C. Nadelson (Eds.), *Women physicians in leadership roles*. Washington DC: American Psychiatric Press.
- Muñoz Gonzalez, J. (1987). Evolución del psicoanálisis en España (1923–1936). Doctoral thesis, University of Murcia.
- Muñoz, María Luisa. (1989, May–November). Contribución a la historia del movimiento psicoanalítico en España. *Revista de psicoanálisis*. Madrid.

- Mucchieli, Laurent. (1994). *Histoire de la criminologie française*. Paris: L'Harmattan.
- Muensterberger, Werner. (1970). *Man and his Culture: Psychoanalytic Anthropology after "Totem and Taboo."* New York: Taplinger.
- Muller, John. (1985). Lacan's mirror stage. *Psychoanalytical Inquiry*, 5, 233–252.
- Mulvey, Laura. (1977). Visual pleasure and narrative cinema. In K. Kay, G. Peary (Eds.), *Women and the cinema* (pp. 412–428). New York: Dutton.
- Munich, R.L. (1997). Contemporary treatment of schizophrenia. *Bulletin of the Menninger Clinic*, 61, 189–221.
- Murray, Henry A. *Explorations in Personality*. New York: Oxford University Press, 1938.
- Murray, L., Cooper, P. J., and Stein, A. (1991). Postnatal depression and infant development. *British Medical Journal*, 302, 978–979.
- Musatti, Cesare. (1949). *Trattato di psicoanalisi*. Turin, Italy: Boringhieri-Einaudi.
- . (1961). Marco Levi Bianchini. *Rivista di psicoanalisi*, 7, 1.
- . (1987). *Chi ha paura del lupo cattivo?* Roma: Riuniti.
- . (1987). *Curar nevrotici con la propria autoanalisi*. Milano: A. Mondadori.
- . (1988). *Psicoanalisti e pazienti a teatro, a teatro!*. Milano: A. Mondadori.
- Myers, Isabel, and Myers, Peter (1980). *Gifts Differing*. Palo Alto, CA: Consulting Psychologists Press.
- Myers, Wayne A. (1989). The traumatic element in the typical dream of feeling embarrassed at being naked. *Journal of the American Psychoanalytic Association*, 37, 117–130.
- Nacht, Sacha. (1938). *Le Masochisme. Étude historique, clinique, psychogénétique et thérapeutique*. Paris, Denoël.
- . (1950). *De la pratique à la théorie psychanalytique*. Paris, Presses Universitaires de France.
- . (1954). The difficulties of didactic psychoanalysis in relation to therapeutic psycho-analysis. *International Journal of Psychoanalysis*, 35 (2), 250–253.
- . (1963). *La Présence du psychanalyste*. Paris, Presses Universitaires de France.
- . (1971). *Guérir avec Freud*. Paris, Presses Universitaires de France.
- . (1971). Le transfert. In *Guérir avec Freud* (pp. 41–43). Paris: Payot. (Original work published 1965)
- Nacht, Sacha, and Lebovici, Serge. (1958). Indications et contre-indications de la psychanalyse chez l'adulte. In Sacha Nacht (Ed.), *Psychanalyse d'aujourd'hui*. Paris: Presses Universitaires de France.
- Nagera, Humberto. (1964). On arrest in development, fixation, and regression. *Psychoanalytic Study of the Child*, 19, 222–239.
- Nasio, Jean-David. (1987). *Le Silence en psychanalyse*. Paris: Rivages.
- Nathan, Tobie. (1986). *La folie des autres: traité d'ethnopsychiatrie clinique*. Paris: Dunod.
- Nathanson, Donald L. (Ed.). (1987). *The many faces of shame*. New York and London: Guilford Press.
- Natterson, Joseph M. (1966). Theodor Reik: Masochism in modern man. In Alexander, Franz, Eisenstein, S., and Grotjahn, Martin (Eds.). *Psychoanalytic pioneers*. New York and London: Basic Books, 249–264.
- Neidisch, S. (1921). Dr Tatiana Rosenthal, Petersburg. *Internationale Zeitschrift für Psychoanalyse*, 7, 384–385.
- Nemes, Lívia. (1984). Hermann Imre munkássága. In *Hermann Imre "Az ember ő si ösztönei"* (p. 586–612). Budapest: Magvető.
- . (1985). The fate of the hungarian psychoanalysts during the time of fascism. *Sigmund Freud House Bulletin*, 9, 20–28.
- Nemes, L. (1980). Biographical notes of Professor Imre Hermann, *International Review of Psychoanalysis*, 7, 1–2.
- Neri, Claudio. (1997). *Group*. (Christine Trollope, Trans.). Rome, London and Philadelphia: Jessica Kingsley.
- Nersessian, Edward. (1998). A cat as fetish: a contribution to the theory of fetishism. *International Journal of Psychoanalysis*, 79, 713–726.
- Neubauer, Peter B. (1985). Preoedipal objects and object primacy. *Psychoanalytic Study of the Child*, 40, 163–182.
- Neumann, Erich. (1955). *The great mother: An analysis of the archetype*. London: Routledge.
- . (1973). *The child: structure and dynamics of the nascent personality*. (Ralph Manheim, Trans.). London: Hodder and Stoughton. (Original work published 1963)
- Neyraut, Michel. (1960). Á propos de la mythomanie. *L'Évolution psychiatrique*, 4, 533–558.
- . (1974). *Le transfert*. Paris: Presses Universitaires de France.
- . (1978). *Les logiques de l'Inconscient*. Paris: Hachette.

- . (1991). Nécrologie de Serge Viderman. *Le Monde*, 7 November 1991.
- Neyraut-Sutterman, Marie-Thérèse. (1970). Parricide et épilepsie: À propos d'un article de Freud sur Dos-  
toïewski. *Revue Française de Psychanalyse*, 34, 4, 635–652.
- . (1975). Preface to Tausk, *Oeuvres psychanalytiques*. Paris: Payot.
- Niémetz, Serge. (1996). *Stefan Zweig: Le voyageur et ses mondes*. Paris: Belfond.
- Nicolaïdis, Graziella, and Nicolaïdis, Nicos. (1994). *Mythologie grecque et Psychanalyse*. Paris: Delachaux & Niestlé.
- Nicolaïdis, Nicos. (1988). *La théophagie. Oralité primaire et métaphorique*. Paris: Dunod.
- . (1993). La Force perceptive de la représentation de la pulsion. Paris: Presses Universitaires de France.
- Nicolas, André. (1969). *Marcuse, ou la quête d'un univers trans-prométhéen*. Paris: Seghers.
- Niederland, William G. (1974). *The Schreber case: Psychoanalytic profile of a paranoid personality*. New York: Quadrangle.
- Nikolic, S. (1987). La psychiatrie en Yougoslavie. *Psychiatrie française*, 6, 41–51.
- Nin, Anaïs. (1936). *The house of incest, a prose poem*. Paris: Siana Press.
- . (1959). *Cities of the interior*. Athens, OH: The Swallow Press.
- . (1966–80). *The diary of Anaïs Nin, 1931–1974*. (G. Stuhlman, Ed.). New York: Harcourt, Brace and World.
- . (1978–85). *The early diary of Anaïs Nin, 1914–1931*. New York: Harcourt, Brace and World.
- . (1986–96). *A journal of love: the unexpurgated diary of Anaïs Nin, 1931–1939*. New York: Harcourt, Brace and World.
- Nitzschke, Bernd. (1989). Freud et Herbert Silberer. Hypothèses concernant les destinataires d'une lettre de Freud de 1922. *Revue internationale d'histoire de la psychanalyse*, 2, 267–277.
- . (1989). Freud und Fechner. Einige Anmerkungen zu den psychoanalytischen Konzepten "Lustprinzip" und "Todestrieb." In *Freud und die akademische Psychologie. Beiträge zu einer historischen Kontroverse*. Munich: Psychologie Verlagsunion.
- . (1991). Freuds Vortrag vor dem israelitischen Humanitätsverein "wie" des Orden B'nai B'rith: "Wir und der Tod" (1915). Ein wiedergefundenes Dokument. *Psyche*, 2, 97–131.
- Noble, Douglas, and Burnham, Donald. (1969). *History of the Washington Psychoanalytic Society and the Washington Psychoanalytic Institute*. Washington DC: Washington Psychoanalytic Society.
- Nodet, Charles-Henri. (1953). À propos du journal de Nijinsky. *L'Évolution Psychiatrique*, 38, (4), 695–710.
- . (1954). Névrose et vie religieuse: la névrose en tant qu'obstacle à la vie, et la névrose, conséquence de l'inhibition religieuse. *Praxis, Revue Suisse de Médecine*, 43, 32.
- . (1957). Psychanalyse et sens du péché. *Revue Française de Psychanalyse*, 21, 791–805.
- . (1958). Quelques réflexions sur les valeurs engagées dans la cure psychanalytique. *Revue Française de Psychanalyse*, 22, (3), 343–359.
- . (1982). "Sciences humaines et religion." In *Psychanalyse et expérience humaine*. Paris: Le Cerf.
- Nosek, Leopold, et al. (1994). *Álbum de família: imagens, fontes e idéias da psicanálise em São Paulo*. São Paulo: Casa do psicólogo.
- Novelletto, Arnaldo (1989). *L'Italia nella psicoanalisi*. Rome: Istituto della Enciclopedia italiana.
- . (1995). Emilio Servadio. *Rivista di psicoanalisi*, 61 (1), pp. 171–179.
- Novick, Jack. (1980). Negative therapeutic motivation and negative therapeutic alliance. *Psychoanalytic Study of the Child*, 35, 299–320.
- Novick, Kerry Kelly and Novick, Jack. (1994). Postoedipal transformations: latency, adolescence, pathogenesis. *Journal of the American Psychoanalytic Association*, 42, 143–170.
- Noy, Pinhas. (1973). Symbolism and mental representation. *Annual of Psychoanalysis*, 1, 125–158.
- Nunberg, Hermann. (1930). The synthetic function of the ego. *International Journal of Psychoanalysis*, 7.
- . (1950). "A Commentary on Freud's 'An Outline of Psychoanalysis,'" *Psychoanalytic Quarterly*, XIX (2), 227–250.
- . (1955). *Principles of psychoanalysis*. New York: International Universities Press.
- . (1956). Character and neurosis. *International Journal of Psychoanalysis*, 37 (1), 36–45.
- Nunberg, Hermann, and Federn, Ernst (Eds.). (1962–1975). *Minutes of the Vienna Psychoanalytic Society* (Vols. 1–4). New York: International Universities Press; (1976–1981). *Die Protokolle der Wiener Psychoanalytischen Vereinigung* (Vols. 1–4). Frankfurt-am-Mein: S. Fischer.

- Oberholzer, Emil. (1922). Der Neurose entgegen. *Schweizerische pädagogische Zeitschrift*, 10 (32), 168–174.
- . (1922). Phobie eines sechsjährigen Knaben. *Schweizerische pädagogische Zeitschrift*, 18–21.
- Oberndorf, Carl P. (1945). Smith Ely Jelliffe. *International Journal of Psychoanalysis*, 26, 186–188.
- Obholzer, Karin. (1982). *The Wolf-Man: conversations with Freud's patient—sixty years later*. (Michael Shaw, Trans.). New York: Continuum.
- Ochonisky, Jean. (1984). L'automutilation a-t-elle un sens? *Neuropsychiatrie de l'enfance et de l'adolescence*, 32, 171–181.
- Odier, Charles. (1927). Contribution à l'étude du Surmoi et du phénomène moral. *Revue française de psychanalyse*, 1 (1), 4–75.
- . (1943). *Les Deux Sources consciente et inconsciente de la vie morale*. Neuchâtel, France: La Baconnière.
- . (1950). *L'Homme esclave de son infériorité*. Neuchâtel, France: Delachaux & Niestlé.
- Ogden, Thomas H. (1982). *Projective identification and psychotherapeutic technique*. New York, Jason Aronson.
- . (1983). The concept of internal object relations. *International Journal of Psychoanalysis*, 64, 227–242.
- . (1987). The transitional oedipal relationship in female development. *International Journal of Psychoanalysis*, 68, 485–498.
- . (1989). On the concept of an autistic-contiguous position. *International Journal of Psychoanalysis*, 70, 127–140.
- . (1989). The threshold of the male Oedipus Complex. *Bulletin of the Menninger Clinic*, 53, 394–413.
- . (1991). Analysing the matrix of transference. *International Journal of Psychoanalysis*, 72, 593–606.
- . (1994). *Subjects of analysis*. Northvale, NJ: Aronson, Inc.
- . (1997). Reverie and interpretation. *Psychoanalytic Quarterly*, 66, 567–595.
- Ogilvie, Bertrand. (1993). Spinoza dans la psychanalyse. In Olivier Bloch (Ed.), *Spinoza au XXe siècle* (pp. 549–571). Paris: Presses Universitaires de France.
- Ohayon, Annick. (1994). Lectures de la psychanalyse dans *L'Année psychologique* de Piéron, 1913–1945. *Actes du XIIe Congrès annuel de Cheiron Europe*. p. 263–270.
- Okano, K.-I. (1994). Shame and social phobia: a trans-cultural viewpoint. *Bulletin of the Menninger Clinic*, 58, 323–338.
- Okonogi, Keigo (1995). A history of psychoanalysis in Japan. In Peter Kutter (Ed.), *Psychoanalysis International, A Guide to Psychoanalysis throughout the World* (Vol. 2). Stuttgart-Bad Cannstatt: Frommann-Holzboog.
- . (1995). A history of psychoanalysis in Japan. In Peter Kutter (Ed.), *Psychoanalysis international: a guide to psychoanalysis throughout the world* (Vol. 2). Stuttgart–Bad Cannstatt, Germany: Frommann-Holzboog.
- Oldham, John M., and Bone, Stanley. (Eds.). (1994). *Paranoia: new psychoanalytic perspectives*. Madison, CT: International Universities Press.
- Olds, David. (2000). A semiotic model of mind. *Journal of the American Psychoanalytic Association*, 48, 497–530.
- Olivares, Juan Antonio. (1984). Breve reseña histórica de la Asociación venezolana de psicoanálisis. *Psicoanálisis*, 1, 117–124.
- Opatow, Barry. (1997). The real unconscious: psychoanalysis as a theory of consciousness. *Journal of the American Psychoanalytic Association*, 45, 865–890.
- Oppenheim, Hermann. (1889). *Die traumatischen Neurosen*. Berlin: A. Hirschwald.
- Oppenheimer, Agnès (1996). *Kohut et la psychologie du self*. Paris: Presses Universitaires de France.
- . (1985). Qu'est-ce que la métapsychologie. *Revue française de psychanalyse*, 49 (5), 1197–1216.
- . (1994). *Enfant, enfance, infantile*. *Revue Française de Psychanalyse*, 58, 3, 707.
- . (1995). *Psychanalyse du Moi, psychologie du Moi et psychologie du Self*. *Encyclopédie médico-chirurgicale* (Vol. *Psychiatrie*).
- . (1996). *Kohut et la psychologie du self*. Paris: Presses Universitaires de France.
- . (1998). *Heinz Kohut*. Paris: Presses Universitaires de France.
- Orange, Donna. (1995). *Emotional understanding. Studies in psychoanalytic epistemology*. New York: Guilford Press
- . (2002). There is no outside: empathy and authenticity in psychoanalytic process. *Psychoanalytical Psychology*, 19, 686–700.
- . (2003). Why language matters to psychoanalysis. *Psychoanalytic Dialogues*, 13, 77–104.

- Ornstein, Anna, and discussants. (1998). The fate of narcissistic rage in psychotherapy. *Psychoanalytical Inquiry*, 18, 55–70.
- Ornstein, Paul H. Selected problems in learning how to analyze. *International Journal of Psychoanalysis* 48, (1967). 448.
- Ornston, Darius Gray. (1992). Improving Strachey's Freud. In Darius Gray Ornston (Ed.), *Translating Freud* (pp. 1–23). New Haven: Yale University Press.
- . (1992). Improving Strachey's Freud. In Darius Gray Ornston (Ed.), *Translating Freud*. New Haven, CT: Yale University Press.
- O'Shaughnessy, Edna. (1999). Relating to the super-ego. *International Journal of Psychoanalysis*, 80, 861–870.
- Ossipov, Nikolai Jegrafovitch. (1908). Psychologische und psychopathologische Einsichten S. Freuds in der deutschen Literatur bis 1907. *Zeitschrift für Neuro-pathologie und Psychiatrie S.S. Korsakowa*, 564–584.
- . (1912). Das zwanghafte Lächeln. *Zeitschrift für Neuropathologie und Psychiatrie S.S. Korsakowa*, 4, 3–11.
- . (1923). Tolstois Kindheitserinnerungen. *Imago*, 2, 1–171.
- . (1931). Revolution und Traum. *Wissenschaftliche Arbeit der russischen Universität in Prag*, 4, 175–203.
- Ostow, Mortimer. (1959). A primal horde dream. *Psychoanalytic Quarterly*, 28, 470–480.
- Otto, Rudolf. (1926). *The holy: an inquiry into the non-rational factor in the idea of the divine and its relation to the rational* (John W. Harvey, Trans). London: Oxford University Press. (Original work published 1917)
- Pérez-Sánchez, Manuel. (1981). *L'observation des bébés*. Paris: Clancier-Guénéaud.
- . (1984). Inicios del movimiento psicoanalítico. *Revista catalana de psicoanálisis*, 1, 1.
- . (1990). *Baby Observation*. Perth: Clunie Press.
- Pérez Sánchez, Manuel, and Abello, Nuria. (1981). Unité originaire: Narcissisme et homosexualité dans les ébauches de l'oedipe. *Revue française de psychanalyse*, 45 (4), 777–786.
- Pötzl, Otto. (1917). Experimentell erregte Traumbilder in ihren beziehungen zum indirekten sehen. *Zeitschrift für die gesamte Neurologie und Psychiatrie*, 37, 3–4.
- . (1960). Preconscious stimulation in dreams, associations, and images. In *Classical studies*, with Allers, Rudolf, and Teler, Jakob. New York: International Universities Press.
- Pötzl, Otto, with Economo, C., Pick, E., Molitor, H., and Strasser, A. (1929). *Der Schlaf. Mitteilungen und Stellungnahme zum derzeitigen Stande des Schlafproblems*. Munich.
- Pabst, Georg Wilhelm. (1926). *Geheimnisse einer Seele (Secrets of a Soul)*. Neumann-film de Ufa-Kulturabteilung, Berlin.
- Paikin, Henning. (1992). Denmark. In P. Kutter (Ed.), *Psychoanalysis international. A guide to psychoanalysis throughout the world* (Vol. 1, Europe). Cannstatt: Frommann-Holzboog.
- Palacio Espasa, Francisco. (1993). *La pratique psychothérapique avec l'enfant*. Paris: Bayard.
- . (1997). Défenses mélancholiques versus défenses maniaques. *Revue française de psychanalyse*, 41 (1–2), 217–226.
- Palmier, Jean Michel. (1969). *Sur Marcuse*. Paris: Union générale d'éditions. (Also published under the title *Présentation d'Herbert Marcuse*.)
- . (1969). *Lacan*. Paris: Éditions universitaires.
- . (1982). La psychanalyse en Union soviétique. In Roland Jaccard (Ed.). *Histoire de la psychanalyse* (Vol. 2). Paris: Hachette.
- Paniagua, Cecilio. (2001). The attraction of topographical technique. *International Journal of Psychoanalysis*, 82, 671–684.
- Pankow, Gisela. (1957). *Dynamische strukturierung in der psychose, beiträge zur analytischen psychotherapie*. Bern: Hans Huber.
- . (1973). The body image in hysterical psychosis. *International Journal of Psychoanalysis*, 55, 3, 407–414.
- . (1980). Rejection and identity. *International Review of Psycho-Analysis*, 7, 3, 319–32.
- . (1983). *L'Homme et sa psychose*. 3d ed. Paris: Aubier-Montaigne. (Original work published 1969)
- . (1983). *Structure familiale et psychose*. Paris: Aubier-Montaigne. (Original work published 1973).
- . (1987). *L'Être-là du schizophrène*. Paris: Aubier-Montaigne. (Original work published 1981)
- Pankow, Gisela (Ed.). (1984). *Vingt-cinq années de psychothérapie analytique des psychoses*. Paris: Aubier-Montaigne.
- Pao, Ping-Nie. (1975). The place of Federn's ego psychology in a contemporary theory of schizophrenia. *International Review of Psychoanalysis*, 2, 467–480.
- . (1979). *Schizophrenic disorders: Theory and treatment from a psychodynamic point of view*. New York: International Universities Press.

- Papadopoulos, Renos K. (1996). Archetypal family therapy: Developing a Jungian approach to working with families. In Laura S. Dodson and Terrill L. Gibson (Eds.), *Psyche and family: Jungian applications to family therapy*. Wilmette, IL: Chiron Press.
- Pappenheim, Else. (1975). On Meynert's Amentia, *History of Medicine*, 9, 3–4.
- Paquet, Alfons. (1930). Zum Goethepreis 1930. Rede im Südwestdeutschen Rundfunk am 28.8.1930. In *Die Psychoanalytische Bewegung*. p. 426–430.
- Paradis, André. (1988). La naissance de la psychanalyse à Montréal. *Revue d'histoire de l'Amérique française*, 41(3), 443–446. (Reprinted from *Frayages, numéro spécial* (1987).)
- Parat, Catherine. (1964). Le changement d'objet. In *L'Affect partagé* (p. 36–47). Paris: Presses Universitaires de France.
- . (1988). *Dynamique du sacré*. Lyon: Césura.
- . (1995). *L'affect partagé*. Paris: Presses Universitaires de France.
- . (1996). À propos de l'amour et de l'amour de transfert. *Revue française de psychanalyse*, 60, 3, 643–662.
- Parcheminey, Georges. (1932). L'hystérie de conversion. *Revue Française de Psychanalyse*, 5, 1, 106–140.
- . (1948). La problématique du psycho-somatique. *Revue Française de Psychanalyse*, 12, 2, 233–249.
- Parens, Henri. (1979). Ambivalence: drives, symbiosis—separation-individuation process. *Psychoanalytic Study of the Child*, 34, 385–420.
- Parin, Paul. (1968). Philipp Sarasin: 80 Jahre. *Bulletin der Schweizerischen Gesellschaft für psychanalyse*, 7, 1–2.
- Parin, Paul, Morgenthaler, Fritz, and Parin-Matthèy, Goldy. (1963). *Die Weissen denken zuviel. Psychoanalytische Untersuchungen bei den Dogon in Westafrika*. Zürich: Atlantis.
- . (1971). *Fürchte Deinen Nächsten wie Dich Selbst: Psychoanalyse und Gesellschaft am Modell der Agni in Westafrika*. Frankfurt am Main: Suhrkamp.
- Paris, Bernard. (1994). *Karen Horney: A psychoanalyst's search for self-understanding*. New Haven, CT: Yale University Press.
- Parkin, Allan. (1987). *History of psychoanalysis in Canada*. Toronto: Toronto Psychoanalytical Society.
- Parres Ramón and Santiago Ramírez (1966), "Historia del movimiento psicoanalítico en México. In Fr. Alexander, S. Eisenstein, and M. Grotjahn (Eds.), *Psychoanalytic Pioneers*, New York and London: Basic Books.
- Parsons, Michael. (1990). Marion Milner's 'answering activity'sthetik. *Kulturkritik*, II, pp. 61–75.
- Pasche, François. (1979). Le "Prométhée" d'Eschyle, ou les Avatars du contre-cœdipe paternal. *Revue française de psychanalyse*, 43 (3), 401–407.
- Pasche, Francis. (1960). Le symbole personnel. In *À partir de Freud*. Paris: Payot.
- . (1965). L'anti-narcissisme. *Revue française de psychanalyse*, 29 (5–6), 503–518.
- . (1969). *À partir de Freud*. Paris: Payot.
- . (1981). Métaphysique et inconscient. *Revue Française de Psychanalyse*, 45 (1), 9–30.
- . (1983). L'imgo zero. *Revue Française de Psychanalyse*, 47, 4, 939–952.
- . (1988). Travail de construction ou, si l'on préfère, de reconstruction, S. Freud, in Third Symposium of the European Federation of Psychoanalysis, Stockholm, 1988, on "Construction and Reconstruction." *Bulletin de la Fédération européenne de psychanalyse*, 31, 19–31.
- . (1993). Mères archaïques et subjectivation. *Devenir*, 5, 4, 67–77.
- . (1996). Peur de la mort, angoisse de mort, défense du Moi. *Revue Française de Psychanalyse*, 60, 1, 49–53.
- . Du surmoi ambivalent au surmoi impersonnel. *Bulletin Méditerranéen de la Société Psychanalytique de Paris*, 1, 7–19.
- Pauskukas R.A. (Ed.). (1993). *The complete correspondence of Sigmund Freud and Ernest Jones 1908–1939*. Cambridge, MA and London: Harvard University Press.
- Payne, Sylvia M. (1935). The conception of femininity. *British Journal of Medical Psychology*, 15, 18–33.
- . (1939). Some observations on the ego development of a fetishist. *International Journal of Psychoanalysis*, 20, 161–170.
- . (1943). Contribution to the discussion of the fundamentals of technique. In King, Steiner (Eds.): *The Freud-Klein controversies 1941–1945*. (p. 648–652). London: Institute of Psycho-Analysis-Routledge, 1991.
- . (1943). The principles and methods of the training of child psycho-analysts. *International Journal of Psychoanalysis*, 24, 61–63.
- . (1946). Notes on the theory of psycho-analytical therapy and its connection with the theory of technique. *International Journal of Psychoanalysis*, 27, 12–19.



- Peck, John S. (1966). Ernst Simmel: psychoanalytic pioneering in California. In F. Alexander, S. Eisenstein, M. Grotjahn (Eds.), *Psychoanalytic pioneers*. New York: Basic Books.
- Peller, Lili E. (1965). Comments on libidinal organizations and child development. *Journal of the American Psychoanalytic Association*, 13, 732–7.
- Penot, Bernard. (1998). La passion du sujet entre pulsion et signifiante. *Bulletin de la Société de psychanalyse de Paris*, 51.
- Peraldi, François. (1981–91). Séminaires sur les premières années de l'œuvre de Lacan. <http://www3.sympatico.ca/jbeili>.
- . (1981). Polysexuality. *Semiotexte*, 4, 1, 167–170.
- . (1987). La marge psychanalytique. *Frayages*, 3, 127–136.
- . (1991). L'expérience du silence. *Texte*, 10, 189–219.
- Perestrello, Danilo. (1954). Headache and primal scene. *International Journal of Psychoanalysis*, 35, 219–223.
- . (1969). Sigmund Freud medico. *Revista Uruguaya de Psicoanálisis*, 11, 3–4.
- . (1973). Contribuição da psicanálise a medicina. *Revista Latina-Americana de Psicanálise*, 5, 3.
- . (1974). *A medicina da Pessoa*. Rio de Janeiro: Livraria Atheneu.
- . (1987). *Trabalhos escolhidos*. Rio de Janeiro: Livraria Atheneu.
- Perestrello, Marialzira. (1985). Primeiros encontros com a psicanálise, 1899–1937; Os precursores do movimento psicanalítico no Brasil, 1899–1937. *Jornal brasileiro de psicanálise*, 35 (4), 195–208.
- . (1992). *A psicanálise no Brasil: encontros psicanalítico*. Rio de Janeiro, Brazil: Imago.
- . (1992). Histoire de la psychanalyse au Brésil des origines à 1937. *Frénésie*, 2 (10), 283–304.
- Perestrello, Marialzira, et al. (1986). *História da Sociedade brasileira de psicanálise do Rio de Janeiro: suas origens e fundação*. Rio de Janeiro: Imago.
- Perret-Catipovic, Maja, and Ladame, François (Eds.). (1997). *Adolescence and psychoanalysis: the story and the history*. (Philip Slotkin, Trans.). London: Karnac.
- Perrier François. (1994). Phobies et hystérie d'angoisse. In Jacques Sédat (Ed.), *La Chaussée d'Antin* (New rev. ed., p. 300–325). Paris, Albin Michel. (Original work published 1956)
- . (1956). "Phobies et hystérie d'angoisse." *Psychanalyse*, 2, 165–196.
- . (1967). L'érotomanie. In P. Aulagnier-Spaurani et al., *Le Désir et la Perversion* (p. 129–162). Paris: Le Seuil.
- . (1978). *La chaussée d'Antin (incl. Perrier's unpublished correspondence with Lacan, biography and bibliography established by J. Sédat)*. Paris: Albin Michel; new ed. 1994.
- . (1984). *Les corps malades du signifiant: séminaires 1971–1972*. Paris: InterÉditions.
- . (1985). *Double lecture: le transsubjectal: séminaires 1973–1974*. Paris: InterÉditions.
- . (1994). *La chaussée d'Antin* (new ed.). Paris: Albin Michel.
- . (1994). Psychanalyse de l'hypocondriaque. In Jacques Sédat (Ed.), *La Chaussée d'Antin* (rev. ed.). Paris: Albin Michel. (Original work published 1959)
- . (1994). Thanatol. In his *La chaussée d'Antin*, pp. 537–568. Paris: Albin Michel. (Original work published 1974)
- Perrier, François, and Granoff, Vladimir. (1960). *Le désir et le féminin*. Paris: Aubier.
- Perron, Roger. (1981). Note sur la notion de structure. *Revue française de psychanalyse*, 45, 4, 1059–65.
- . (1990). Médecins et non-médecins dans l'histoire de la Société psychanalytique de Paris. *Revue internationale d'histoire de la psychanalyse*, 3, 167–198.
- . (1994). *Une fiction préhistorique de Freud*. In A. Fine, R. Perron, F. Sacco (Eds.), *Psychanalyse et préhistoire*. Paris: Presses Universitaires de France.
- . (1995). Prendre pour vrai. *Revue française de Psychanalyse*, 59, 2, 499–512.
- . (1995). Théories de la psychogenèse. In *Encyclopédie médico-chirurgicale*, volume *Psychiatrie*. Paris: E.M.-C., fasc. 37-810-F-30.
- Perron, Roger, and Perron-Borelli, Michèle. (1987). Fantasma et action. *Revue française de psychanalyse*, 51 (2), 539–637.
- . (1994). *Le complexe d'Œdipe*. Paris: Presses Universitaires de France.
- . (1997). *Fantasma, action, pensée*. Algiers, Algeria: Éditions de la Société algérienne de psychologie.
- Perron-Borelli, Michèle (1997). *Dynamique du fantasme*. Paris: Presses Universitaires de France.
- Perrotti, Nicola. (1989). *L'Io legato e la libertà*. Rome: Astrolabio.
- Perry, Helen Swick. (1982). *Psychiatrist in America. The life of Harry Stack Sullivan*. Cambridge, MA: The Belknap Press of Harvard University.

- Petacchi, Giancarlo. (1987). Vita di pionieri. In A. M. Accerboni (Ed.), *La cultura psicoanalitica*. (p. 168–173). Pordenone: Studio Tesi.
- Petot, Jean-Michel. (1982). L'archaïque et le profond dans la pensée de Melanie Klein. *Nouvelle Revue de psychanalyse* 26, pp. 253–272.
- . (1982). *Mélanie Klein*. (Christine Trollope, Trans.). Madison, CT: International Universities Press.
- Pfister, Oskar. (1917). *The psychoanalytic method*. (Charles Rockwell, Trans.). New York: Moffat. (Original work published 1913)
- . (1920). J. Piaget, “La psychanalyse et la pédagogie.” *Imago*, 6, 3, 294–295.
- . (1923). *Some applications of psycho-analysis*. New York: Dodd, Mead and Company; London: G. Allen and Unwin.
- . (1927). *Analytische seelsorge. Einführung in die praktische psychanalyse für Pfarrer und Laien*. Göttingen: Vandenhoeck and Ruprecht.
- . (1928). The illusion of a future. *International Journal of Psychoanalysis*, 74, 1993, 557–579.
- . (1948). Christianity and fear. London: G. Allen and Unwin.
- . (1993). The illusion of a future. *International Journal of Psychoanalysis*, 74, 557–579. (Original work published 1928)
- Pfrimmer, Théo. (1982). *Freud, lecteur de la Bible*. Paris: Presses Universitaires de France.
- Phillips, Adam. (1988). *Winnicott*. London: Fontana Press.
- Piaget, Jean. (1923). La pensée symbolique et la pensée de l'enfant. *Archives de psychologie*, 18(72), 273–304.
- . (1954). *The construction of reality in the child* (Margaret Cook, Trans.). New York: Basic Books. (Original work published 1937)
- . (1972). La psychologie. In his *Épistémologie des sciences de l'homme* (pp. 133–250). Paris: Gallimard.
- . (1973). *Child and reality: problems of genetic psychology*. New York: Grossman.
- . (1995). Psychoanalysis in its relations with child psychology. In Gruber, Howard E., and Vonèche, Jacques J. (Eds.). *The essential Piaget*. Northvale, NJ: Jason Aronson. (Original work published 1920)
- Picard, Pierre Alexandre. (1972). Hesnard et le début de la psychanalyse en France. *Psychologie médicale*, IV, 1, p. 73–85.
- Pichon, Édouard. (1928). Position du problème de l'adaptation réciproque entre la société et les psychismes exceptionnels. *Revue française de psychanalyse*, 2 (1), 135–170.
- . (1934). Eugénie Sokolnicka. *Revue française de psychanalyse*, 9 (4), 559–588.
- . (1936). De Freud à Dalbiez. *Revue Française de Psychanalyse*, 9, 4, 559–588.
- . (1938). La personne et la personnalité vues à la lumière de la pensée idiomatique française. *Revue française de psychanalyse*, 10 (3), 447–461.
- . (1939). La famille devant Lacan. *Revue Française de Psychanalyse*, 11, 1, 107–135.
- Pichon, Édouard, and Damourette, Jacques. (1925). La grammaire en tant que mode d'exploration de l'Inconscient *L'Évolution psychiatrique*, 1, 237–257.
- Pichon, Édouard, and Parcheminey, Georges. (1928). Sur les traitements psychothérapeutiques courts d'inspiration freudienne chez les enfants. *Revue Française de Psychanalyse*, 2, 4, 711–720.
- Pichon-Rivière, Enrique. (1970). *Del psicoanálisis a la psicología social*. Buenos Aires: Galerna.
- . (1980). *Teoría del vínculo*. Buenos Aires: Nueva Visión.
- Pichot, Pierre. (1994). La neurasthénie. *Encéphale*, 20 (3), 540–550.
- Pigman, George W. (1995). Freud and the history of empathy. *International Journal of Psychoanalysis*, 76, 237–256.
- Pinatel, J. (1975). *Traité de droit pénal et de criminologie* (Vol 3: Criminologie, 3rd ed. Paris: Dalloz.
- Pine, Fred. (1994). The era of separation-individuation. *Psychoanalytic Inquiry*, 14, 4–24.
- . (2004). Mahler Monday, November 22, 2004's concepts of symbiosis and separation-individuation: revisited, reevaluated, refined. *Journal of the American Psychoanalytic Association* 52 (2), 511–533.
- Pines, Malcolm. (1991). The development of the psychodynamic movement. In Berrios and Freeman, (Eds.), *150 years of british psychiatry*. London: Gaskell.
- . (1991). A history of psychodynamic psychiatry in Britain. In J. Holmes (Ed.): *Textbook of psychotherapy in psychiatric practice*. Livingstone, England: Churchill.
- . (1995). La dissension dans son contexte: schismes dans le mouvement psychanalytique. *Topique*, 57, 191–206.
- Pines, Malcolm (Ed.). (1985). *Bion and group psychotherapy*. London: Routledge.
- Pinsker, Leon. (1916). *Auto-emancipation*. New York, Federation of American Zionists. (Original work published 1882)

- Pitres Albert, and Régis, Emmanuel. (1902). *Les obsessions et les impulsions*. Paris: O. Doin.
- Pitt, B. (1968). "Atypical" Depression Following Childbirth. *British Journal of Psychotherapy*, 114, 1325–1335.
- Pizer, Stuart A. (1992). The negotiation of paradox in the analytic process. *Psychoanalytic Dialogues*, 2, 215–240.
- Plänkers, Tomas. (1993). Vom Himmel durch die Welt zur Hölle. Zur Goethe-Preisverleihung an Sigmund Freud im Jahre 1930. *Jahrbuch für Psychoanalyse*, 30, p. 167–180.
- . (1996). Die Verleihung des Frankfurter Goethe-Preises an Sigmund Freud 1930. Die Sitzungssprotokolle des Goethe-Preiskuratoriums. In Tomas Plänkers, et al., *Psychoanalyse in Frankfurt a. M. Zerstörte Anfänge, Wiederannäherung und Entwicklungen* (p. 254–331). Tübingen: Diskord.
- . (1996). Hygiene der Seele. Heinrich Meng (1887–1972). In Tomas Plänkers, et al.: *Psychoanalyse in Frankfurt a. M. Zerstörte Anfänge, Wiederannäherung und Entwicklungen*, Tübingen: Diskord, p. 109–140.
- Plänkers, Tomas, Laier, Michael, Otto, Hans-Heinrich, et al. (1996). *Psychoanalyse in Frankfurt am Main.: zerstörte Anfänge, Wiederannäherung, Entwicklungen*. Tübingen, Diskord.
- Plata Mújica, Carlos. (1989), *Metapsicología y Técnica Psicoanalítica*. Bogotá: Ed. Tercer Mundo Editores.
- Poisson, Jacques. (1921, April). Vers une nouvelle unité plastique. *La Vie des lettres et des arts*, IV, 445–448.
- . (1923, April). Littérature moderne et psychanalyse. *La Vie des lettres et des arts*, XIV, 71–74.
- . (1925). Cinéma et psychanalyse. *Les cahiers du mois*, 16–17, 175–176.
- Pokorny, Alois. (1865). *Jarhesberichte des Leopoldstädter Kommunal-Real- und Obergymnasiums in Wien. Wien 1865–1874*. Vienna: Verlag des Leopoldstädter Real- und Obergymnasiums.
- Poland, Warren S. (1984). On the analyst's neutrality. *Journal of the American Psychoanalytic Association*, 32, 283–300.
- . (1984). The analyst's words: empathy and countertransference. *Psychoanalytic Quarterly*, 53, 421–424.
- . (1988). Insight and the analytic dyad. *Psychoanalytic Quarterly*, 57, 341–369.
- . (1990). Gift of laughter: Development of a sense of humor in clinical analysis. *Psychoanalytic Quarterly*, 59, 197–225.
- . (1992). From analytic surface to analytic space. *Journal of the American Psychoanalytic Association*, 40, 381–404.
- . (1992). Transference: "An original creation". *Psychoanalytic Quarterly*, 61, 185–205.
- Politzer, Georges. (1969). *Écrits 2*. (J. Debouzy, Ed.). Paris: Éditions Sociales.
- . (1994). *Critique of the foundations of psychology: the psychology of psychoanalysis* (Maurice Apprey, Trans.). Pittsburgh: Duquesne University Press. (Original work published 1928)
- Pollak Cornillot, Michèle. (1990). *Freud traducteur. Introduction à la traduction des œuvres de Freud* (Doctoral dissertation, Université René-Descartes, Paris).
- Pollak, Richard. (1997). *The creation of Dr. B.: A biography of Bruno Bettelheim*. New York: Simon and Schuster.
- Pollock, George H. (1978). The Chicago Institute for Psychoanalysis from 1932 to the present. In J. Quen and E. Carlson (Eds.). *American psychoanalysis: Origins and development* (pp. 109–26). New York: Brunner/Mazel.
- . (1988). Notes on abandonment, loss, and vulnerability. *Annual of Psychoanalysis*, 16, 341–370.
- Pongratz, Ludwig J. (1973). Werner W. Kemper. In *Psychotherapie in Selbstdarstellungen* (pp. 259–345). Bern: Hans Huber.
- Pont, Jean-Claude. (1974). *La topologie algébrique des origines à Poincaré*. Paris: Presses Universitaires de France.
- Pontalis, Jean-Bertrand. (1963). Le petit groupe comme objet. In *Après Freud*. Paris: Gallimard, 1968.
- . (1970). La question de la psychanalyse. *Nouvelle Revue de psychanalyse*, p. 5–8.
- . (1978). Les vases non communicants. *N.R.F.*, 302, 26–45.
- . (1981). *Frontiers in psychoanalysis: Between the dream and psychic pain* (Catherine Cullen and Philip Cullen, Trans.). London: Hogarth Press and the Institute of Psycho-Analysis. (Original work published 1977)
- . (1981). Non, deux fois non. *Nouvelle Revue de Psychanalyse*, 24.
- . (1984). Le moment venu. *Nouvelle Revue de psychanalyse*, 30: 5–12.
- . (1988). De la mère, le maternel. In *Perdre de vue*, Paris: Gallimard.
- . (1994). Catalogue 1970–1994. *Nouvelle Revue de psychanalyse*.
- Porge, Erik. (1994). *Vol d'idées?* Paris, Denoël.

- Porot, Antoine. (1952). *Manuel alphabétique de psychiatrie*. Paris: Presses Universitaires de France.
- Porte, Michèle. (1994). *La dynamique qualitative en psychanalyse*. Paris: Presses Universitaires de France.
- . (1998). *Pulsions et politique: Une relecture de l'événement psychique collectif à partir de l'œuvre de Freud*. Paris: Harmattan.
- Porte, Michèle (Ed.). (1994). *Passion des formes. Dynamique qualitative, sémiophysique et intelligibilité. À René Thom*. Paris: E.N.S. Fontenay-Saint Cloud.
- Porto-Carrero, Julio Pires. ([1929] 1934). *Ensaio de psicanálise*. Rio de Janeiro: Flores e Mano, 2d ed.
- . ([1932] 1934). *Psicologia profunda ou psicanálise*. Rio de Janeiro: Irmãos Pongetti.
- . (1934). *Grandezas e misérias do sexo*. Rio de Janeiro: Irmãos Pongetti.
- Potamianou, Anna. (1988). Episkepsis: Pensées autour de la visite d'Anna Freud à Athènes. *Revue internationale d'histoire de la psychanalyse*, 1, 247–254.
- Prado de Oliveira, Luis Eduardo (Ed.). (1979). *Le cas Schreber: contributions psychanalytiques de langue anglaise*. Paris: Presses Universitaires de France.
- . (1997). *Freud et Schreber: les sources écrites du délire, entre psychose et culture*. Paris: Érès.
- Prados, Miguel. (1954). La psychanalyse au Canada. *Revue canadienne de psychanalyse*, 1, 1–33.
- Pragier, Georges. (1955). Un Inédit de Ferenczi. In *Sándor Ferenczi*. Monographies of the *Revue Française de Psychanalyse*. Paris: PUF.
- Prego Silva, Luis E. (1996). Notas y comentarios sobre los orígenes del psicoanálisis de niños en el Uruguay. In *Psicoanálisis de niños y adolescentes en América latina* (Vol. 2, pp. 51–56). Lima, Peru: Fe.P.A.L.
- Pribram, Karl H., and Gill, Merton M. (1976). *Freud's "project" reassessed*. London: Hutchinson.
- Prigogine, Ilya, and Glandsdorf, P. (1973). L'écart à l'équilibre interprété comme une source d'ordre structure dissipatives. *Bulletin de la classe des sciences*, 59, 672–702.
- Pruyser, P.W. (1975). What splits in "splitting"?: Scrutiny of concept. *Bulletin of the Menninger Clinic*, 39, 1–46.
- Psychiatrische Universitätsklinik Burghölzli Zürich. (1970). *1870–1970: Hundert Jahre Festschrift* (pp. 1–87).
- Pulman, Bertrand. (1991). Psychanalyse et anthropologie. *Revue internationale d'histoire de la psychanalyse*, 4, 425–521.
- Pulver, Stanley. (1999). Shame and guilt: a synthesis. *Psychoanalytical Inquiry*, 19, 388–406.
- Putnam, James Jackson. (1915). *Human motives*. Boston: Little, Brown, and Company.
- Puységur, Armand Marie Jacques de Chastenet, marquis de. (1786). *Mémoires pour servir à l'histoire et à l'établissement du magnétisme animal*. London: s.n.
- Quarchioni, Marco. (1988). Marco Levi Bianchini e la "Biblioteca psicoanalitica italiana." *Notizie dalla Delfico*, 1, 3–22.
- Quartier-Frings, Florence. (1997). *René Diatkine*. Paris: Presses Universitaires de France.
- Quinn, Susan. (1987). *A mind of her own: The life of Karen Horney*. New York: Summit Books.
- Quinodoz, Danielle. (1992). The psychoanalytic setting as the instrument of the container function. *International Journal of Psychoanalysis*, 73, 627.
- Quinodoz, Jean-Michel. (1993). *The taming of solitude: separation anxiety in psychoanalysis* (Philip Slotkin, Trans.). London: Routledge.
- Rádo, Sándor. (1928). The problem of melancholia. *International Journal of Psychoanalysis*, 9, 420–438.
- Régis, Emmanuel. (1909). *Précis de psychiatrie* (4th ed.). Paris: Doin.
- Régis, Emmanuel, and Hesnard, Angélo. (1913). La doctrine de Freud et de son école (first part). *L'Encéphale*, 8, 356–378.
- . (1913). La doctrine de Freud et de son école (conclusion). *L'Encéphale*, 8, 537–564.
- . (1914). *La psychanalyse des névroses et des psychoses: Ses applications médicales et extramédicales*. Paris: Alcan.
- Rabain, Jean-François. (1988). La mise en scène du trauma. *Revue française de psychanalyse*, 53 (6), 1373–1389.
- Racamier, Paul-Claude (1992). *Le génie des origines. Psychanalyse et psychoses*. Paris: Payot.
- . (1961). La mère et l'enfant dans les psychoses du post-partum. *Évolution psychiatrique*, 4, 525–570.
- . (1963). Sur la personation. In *De psychanalyse en psychiatrie*. Paris: Payot.
- . (1976). L'interprétation psychanalytique des schizophrénies. In *Encyclopédie médico-chirurgicale*. Paris: EMC.
- . (1979). *La maternalité psychotique. (Commentaires et complément 1978 et 1979)*. Paris: Payot.
- . (1980). *Les schizophrènes*. Paris: Payot.
- . (1989). *Antoedipe et ses destins*. Paris: Apsygée.
- . (1992). *Le génie des origines. Psychanalyse et psychoses*. Paris: Presses Universitaires de France.

- . (1995). *L'inceste et l'incestuel*. Paris: Éditions du Collège de psychanalyse groupale et familiale.
- . (1995). *L'Inceste et l'Incestuel*. Paris: Éditions du Collège de psychanalyse groupale et familiale.
- . (1998). Paradoxalité et ambiguïté. In S. Decobert, J.-P. Caillot, C. Pigott (Eds.), *Vocabulaire de psychanalyse groupale et familiale*, v. 1. Paris: Éditions du Collège de Psychanalyse Groupale et Familiale.
- Racamier, Paul-Claude, et al. (1970). *Le Psychanalyste sans divan*. Paris: Payot.
- Racker, Heinrich. (1951). Observaciones sobre la contratransferencia como instrumento técnico. *Revista de psicoanálisis de la Asociación psicoanalítica argentina*.
- . (1953). A contribution to the problem of countertransference. *International Journal of Psychoanalysis*, 34 (4), 313–324.
- . (1957). *Psicoanálisis del espíritu*. Buenos Aires: Nova. A.P.A.
- . (1957). The meanings and uses of countertransference. *Psychoanalytic Quarterly*, 26 (3), 303–357.
- . (1960). *Estudios sobre técnica psicoanalítica*. Buenos Aires: Editorial Paidós; (1968). *Transference and countertransference*. New York: International Universities Press.
- . (1968). *Transference and countertransference*. New York: International Universities Press. (Original work published 1960)
- Radó, Sándor. (1926). The psychic effects of intoxicants: an attempt to evolve a psycho-analytical theory of morbid cravings. *International Journal of Psychoanalysis*, 7, 396–413.
- . (1933). The psychoanalysis of pharmacothymia. *Psychoanalytic Quarterly*, 2, 1–23.
- . (1956–62). *Psychoanalysis of Behavior*, Vols. 1 and 3. New York: Grune & Stratton.
- . (1969). *Adaptational Psychodynamics*. Jean Jameson and Henriette Klein (Eds.). New York: Science House.
- Raffier-Malosto, Jocelyne. (Ed.). (1996). *Le Dessin de l'enfant. De l'approche génétique à l'interprétation clinique*. Paris: La Pensée Sauvage.
- Raimbault, Émile et al. (1964). *La Formation psychologique des médecins*. Paris: Maloine.
- . (1976). *La Délivrance*. Paris: Mercure de France.
- Raines, Theron. (2002). *Rising to the light: A portrait of Bruno Bettelheim*. New York: Alfred A. Knopf.
- Rambert, Madeleine. (1938). Une nouvelle technique en psychanalyse infantile: le jeu de guignols, *Revue française de psychanalyse*, 10, 1.
- . (1945). *Children in conflict, twelve years of psychoanalytic practice*. (Yvette Moxley, Trans.). New York: International Universities Press, 1949.
- Ranchetti, Michele. (1993). Prefazione In *Opere, Complementi*. Turin: Boringhieri.
- Rand, Nicolas and Torok, Maria. (1995). *Questions for Freud: The secret history of psychoanalysis*. Cambridge: Harvard University Press.
- Rangell, Leo, and Moses-Hrushovski, Rena (Eds.). (1996). *Psychoanalysis at the political border*. Madison, CT: International Universities Press.
- Rangell, Leo. (1971). Elizabeth R. Zetzel. *International Journal of Psychoanalysis*, 52, 229–231.
- . (1981). From insight to change. *Journal of the American Psychoanalytic Association*, 29, 119–142.
- . (1991). Castration. *Journal of the American Psychoanalytic Association*, 39, 3–24.
- . (1996). The “analytic” in psychoanalytic treatment: how analysis works. *Psychoanalytic Inquiry*, 16, 140–166.
- Rank, Beata. (1924). Zur Rolle der Frau in der Entwicklung der menschlichen Gesellschaft (On the role of the woman in the development of human society). *Imago*, 10, 1924, 278–295; Abstract in *International Journal of Psychoanalysis*, 7, 1926, 89.
- . (1942). Where child analysis stands today. *American Imago*, III, (3), 41–60.
- . (1949). Adaptation of the psychoanalytic technique for the treatment of young children with atypical development. *American Journal of Orthopsychiatry*, 19, 130–139.
- . (1955). Intensive study and treatment of preschool children who show marked personality deviations, or atypical development and their parents. In G. Caplan (Ed.), *Emotional problems of early childhood: Proceedings of the International Institute of Child Psychiatry*. New York: Basic Books, 491–501.
- Rank, Otto. (1909). *Der Mythos von der Geburt des Helden*. Leipzig-Wien: F. Deuticke.
- . (1929). *The trauma of birth*. London: Kegan Paul, Trench, Trubner. (Original work published 1924)
- . (1971). *The double: a psychoanalytic study* (Harry Tucker Jr., Trans.). Chapel Hill: University of North Carolina Press. (Original work published 1914)
- . (1975). *The Don Juan legend* (David G. Winter, Trans.). Princeton: Princeton University Press. (Original work published 1922)

- . (2004). *The myth of the birth of the hero: A psychological interpretation of mythology*. (Gregory C. Richter and E. James Lieberman, Trans.). Baltimore: Johns Hopkins University Press. (Original work published 1909).
- Rapaport, David. (1951). *Organization and pathology of thought*. New York: Columbia University Press.
- . (1954). The autonomy of ego. In Robert P. Knight and C. R. Friedman (Eds.), *Psychoanalytic psychiatry and psychology*. New York: International Universities Press. (Original work published 1951)
- . (1959). The structure of psychoanalytic theory: A systematizing attempt. In S. Koch (Ed.), *Psychology: A study of a science*, vol. 3. New York: McGraw-Hill. (Reprinted in *Psychological Issues Monographs*, 6,, 1960.)
- . (1967). The theory of ego autonomy: a generalization. In M. Gill (Ed.), *The collected papers of David Rapaport* (p. 722–744). New York: Basic Books. (Original work published 1957)
- Raphael-Leff, Joan, and Perelberg, Rosine Jozef (Eds.). (1997). *Female experience: Three generations of British women psychoanalysts on work with women*. London: Routledge.
- Rapoport, Danièle. (1972). Le rôle des psychologues dans les services de pédiatrie. In Henri Pieron, Ed., *Traité de psychologie appliquée* (pp. 149–182). Paris : Presses Universitaires de France.
- Rascovsky, Arnaldo. (1956). Beyond the oral stage. *International Journal of Psychoanalysis*, 37, 4.
- . *El Filicidio*. Buenos Aires: Orion, 1973.
- . *El Psiquismo Fetal*. Buenos Aires: Paidós, 1960.
- Rascovsky, Arnaldo, et al. *La universalidad del filicidio*. Buenos Aires: Legase, 1986.
- Rascovsky, Arnaldo, et al. *Niveles profundos del Psiquismo*. Buenos Aires: Sudamericana, 1971.
- Rassial, Jean-Jacques. (1990). *L'Adolescent et le psychanalyse*. Paris: Payot.
- Rathbun, C. (1934). On certain similarities between Spinoza and psychoanalysis. *Psychoanalytic Review*, 21, 1, 1–14.
- Rausky, Franklin. (1977). *Mesmer ou la révolution thérapeutique*. Paris: Payot.
- Ray, Robert B. (1985). *A certain tendency of the hollywood cinema, 1930–1980*. Princeton: Princeton University Press.
- Rayner, Eric. (1991). *The independent mind in British psychoanalysis*. London: Free Association Books.
- . (1995). *Unconscious logic: An introduction to Matte Blanco's bi-logic and its uses*. London: Routledge.
- Reed, Gail S. (1994). *Transference neurosis and psychoanalytic experience: Perspectives on contemporary clinical practice*. New Haven, CT: Yale University Press.
- . (1995). Clinical truth and contemporary relativism: meaning, narration. *Journal of the American Psychoanalytic Association*, 43, 713–740.
- Rees, John Rawlings. (1929). *The health of the mind*. London: Faber & Faber; New York: W. W. Norton, 1951.
- . (1943). Three years of military psychiatry in the United Kingdom. *British Medical Journal*, 2.
- . (1944). A brief impression of British military psychiatry. *Bulletin of the Menninger Clinic*, 8, 29–35.
- . (1945). *The shaping of psychiatry by war*. New York: W. W. Norton.
- Reich, Annie. (1929). Zur Frage der Sexualaufklärung. *Zeitschrift für psychoanalytische Pädagogik*, 3, 98–100.
- . (1951). The discussion of 1912 on masturbation and our present-day views. *Psychoanalytic Study of the Child*, 6, 80–94.
- . (1973). *Psychoanalytic contributions*. New York: International Universities Press.
- Reich, Wilhelm. (1945). *Character analysis: Principles and technique for psychoanalysts in practice and in training* (Theodore P. Wolfe, Trans.). New York: Orgone Institute Press. (Original work published 1933)
- . (1946). *The mass psychology of fascism* (Theodore P. Wolfe, Trans.). New York: Orgone Institute; (1933). *Die Massenpsychologie des Faschismus*. Copenhagen/Prague/Zurich: Verlag für Sexualpolitik.
- . (1948). *The cancer biopathy*. New York: Orgone Institute Press.
- . (1967). *Reich speaks of Freud* (Mary Higgins and Chester M. Raphael, Eds.; Therese Pol, Trans.). New York: Farrar, Straus.
- . (1968). *The function of the orgasm: sex-economic problems of biological energy* (Theodore P. Wolfe, Trans.). London: Panther. (Original work published 1940)
- . (1970). *The mass psychology of fascism* (Vincent R. Carfagno, Trans.). New York: Farrar Straus Giroux.
- . (1972). Dialectical materialism and psychoanalysis. In *Sex-pol; essays, 1929–1934* (Anna Bostok, Tom DuBose, and Lee Baxandall, Trans.). New York: Random House. (Original work published 1929)

- . (1988). *Passion of youth: An autobiography 1897–1922*. New York: Farrar, Straus & Giroux, 178 p.
- Reicheneder, J. G. (1994). “Freud in Berlin 1886. *Luzifer–Amor*, 7, 7–16.
- Reichmayr, Johannes. (1991). Rudolf von Urbantschitsch (Rudolf von Urban), 1879–1964. *Revue internationale d’histoire de la psychanalyse*, 4, 647–658.
- . (1994). *Spurensuche in der Geschichte der Psychoanalyse*. Frankfurt am Main: S. Fischer.
- Reik, Theodor. (1914). Die Couvade und die Psychogenese der Vergeltungsfurcht. *Imago*, 3, 409–455.
- . (1935). *Surprise and the psycho-analyst: on conjecture and comprehension of unconscious processes*. London: Kegan Paul, Trench, Trubner.
- . (1948–1956). *Listening with the third ear*. New York, Grove Press.
- . (1953). *The Haunting Melody: Psychoanalytic Experiences in Life and Music*. New York: Farrar, Straus, and Young.
- . (1956). *The search within. The inner experiences of a psychoanalyst*. New York: Farrar, Straus & Cudahy.
- . (1969). Le patient inconnu. *Études Freudiennes*, 1–2, 7–38.
- . (1973). *Le besoin d’avouer: psychanalyse du crime et du châtement*. Paris: Payot.
- . (1975). *Ritual: psycho-analytic studies* (Douglas Bryan, Trans.). Westport, CT: Greenwood Press. (Original work published 1949)
- Reimer, Jensen, and Paikin, Henning. (1980). On psychoanalysis in Denmark. *Scandinavian Psychoanalytic Review*, 3, 103–16.
- Renik, Owen. (1981). Typical examination dreams, “superego dreams” 189.
- . (1990). Concept of transference neurosis and psychoanalytic methodology. *International Journal of Psychoanalysis*, 71, 197–204.
- . (1992). Use of the analyst as a fetish. *Psychoanalytic Quarterly*, 61, 542–563.
- . (1996). The perils of neutrality. *Psychoanalytic Quarterly*, 65, 495–517.
- . (1998). The analyst’s subjectivity and the analyst’s objectivity. *International Journal of Psychoanalysis*, 79, 487–498.
- Reverchon-Jouve, Blanche, and Jouve, Pierre Jean. (1933). Moments d’une psychanalyse. *Nouvelle Revue Française*, 234, 353–385.
- Rey de Castro, Álvaro. (1991). *Freud y Honorio Delgado: una aproximación psicoanalítica a la prehistoria del psicoanálisis peruano y sus escuelas, el múltiple interés del psicoanálisis-77 años después*. (p. 203–237). Talleres de Artes Gráficas Espino.
- . (1993). Lettres de Sigmund Freud à Honorio Delgado, 1919–1934. *Revue internationale d’histoire de la psychanalyse*, 6.
- Rey, Jean-Michel. (1979). Des mots à l’œuvre. Paris: Aubier-Montaigne.
- . (1984). Freud et l’écriture de l’histoire. *L’Écrit du temps*, 6, 23–42.
- Ribot, Théodule. (1905). *La logique des sentiments*. Paris: Alcan.
- Richards, Angela. (1969). Erläuterungen zur edition. *Studienausgabe* (Vol. 1, pp. 27–32). Frankfurt-am-Main: Fischer.
- Rickman, John. (1928). *The development of the psycho-analytical theory of the psychoses, 1893–1926*. London: Bailliere, Tindall & Cox.
- . (1928). *Index psycho-analyticus, 1893–1926*. London: Hogarth Press and the Institute of Psycho-Analysis.
- . (1949). Sketches of Russian peasant life (1916–1918). In Geoffrey Gorer and John Rickman (Eds.), *The peoples of greater Russia: a psychological study*, 23–89. London: Cresset Press.
- . (1950). Obituary. Susan Sutherland Isaacs C.B.E. M. MA. D. Sc. (Vict), Hon. D. Sc. (Adelaide). *International Journal of Psychoanalysis*, 31, 279–285.
- . (1951). Reflections on the functions and organization of a psycho-analytical society. *International Journal of Psychoanalysis*, 32, 218–237.
- . (1957). *Selected contributions to psycho-analysis*. London: Hogarth Press and the Institute of Psycho-Analysis.
- Ricoeur, Paul. (1965). *History and truth*. (Charles A. Kelbley, Trans.). Evanston, IL: Northwestern University Press. (Original work published 1955)
- . (1970). *Freud and philosophy: An essay on interpretation*. (Denis Savage, Trans.). New Haven: Yale University Press. (Original work published 1965)
- . (1974). *The conflict of interpretations* (Don Ihde, Ed.). Evanston, IL: Northwestern University Press. (Original work published 1969)
- . (1984–1988). *Time and narrative* (Kathleen McLaughlin and David Pellauer, Trans.). Chicago: University of Chicago Press. (Original work published 1985)
- . (1986). The self in psychoanalysis and in phenomenological philosophy. *Psychoanalytical Inquiry*, 6, 437–458.

- Rieder, Ines, and Voigt, Diana. (2000). *Heimliches Begehren: Die Geschichte der Sidonie C. Franz*. Vienna/Munich: Deuticke Verlag.
- Riemann, Fritz. (1966). *Grundformen der Angst*. Munich and Basel: Ernst Reinhardt.
- Ries, Paul. (1995). Popularise and/or be damned. Psycho-analysis and film at the crossroads in 1925, *International Journal of Psychoanalysis*, 76, 759–792.
- Rittmeister, John F. (1936). Die Psychotherapeutische Aufgabe und der neue Humanismus. *Psychiatrische en neurologische Bladen*, 5, 777–796.
- . (1961). Die mystische Krise des jungen Descartes. *Confinia psychiatrica*, 4, 65–98.
- . (1982). Voraussetzungen und Konsequenzen der Jungschen Archetypenlehre. *Psyche*, 36, 1032–1044.
- . (1992). *Hier brannte doch die Welt: Aufzeichnungen aus dem Gefängnis, 1942–1943* (Christine Teller, Ed.). Gütersloh, Germany: Jacob van Hoddis.
- Ritvo, Lucile B. (1990). *Darwin's influence on Freud: a tale of two sciences*. New Haven: Yale University Press.
- . (1990). *L'Ascendant de Darwin sur Freud*. Paris, Gallimard. (Original work published 1974)
- Riviere, Joan. (1929). Womanliness as a masquerade. *International Journal of Psychoanalysis*, 10, 303–313.
- . (1932). Jealousy as a mechanism of defence. *International Journal of Psychoanalysis*, 13, 414–424.
- . (1936). A contribution to the analysis of a negative therapeutic reaction. *International Journal of Psychoanalysis*, 17, 304–320.
- . (1936). On the genesis of psychic conflict in earliest infancy. *International Journal of Psychoanalysis*, 17, 395–422.
- . (1952). The inner world in Ibsen's "Master Builder." *International Journal of Psychoanalysis*, 33, 173–180.
- Rizzo, Francis. (1972). Memoirs of an invisible man; Herbert Graf recalls a half-century in the theater: a dialogue with Francis Rizzo, interview, with 12 illustrations and 2 sketches. *Opera News* 36, part I, 5 Feb. 1972, p. 24–28 ; part II : 12 Feb. 1972, p. 26–29 ; part III : 19 Feb. 1972, p. 26–29 ; part IV : 26 Feb. 1972, p. 26–29.
- Rizzuto, Ana-Maria. (2002). Speech events, language development, and the clinical situation. *International Journal of Psychoanalysis*, 83, 1325–1344.
- . (1990). Origin Freud's concept of object representation: "On Aphasia". *International Journal of Psychoanalysis*, 71, 241–248.
- Roazen, Paul. (1969). *Brother animal. The story of Freud and Tausk*. New York: Alfred Knopf.
- . (1976). *Erik H. Erikson: The power and limits of a vision*. Northvale, New Jersey: Jason Aronson.
- . (1976). *Freud and his followers*. New York: Alfred A. Knopf.
- . (1985). *Helene Deutsch. A psychoanalyst's life*. New York: Anchor.
- . (1993). *Meeting Freud's family*. Amherst: University of Massachusetts Press.
- . (2001). Interview with Philipp Sarasin. In *The historiography of psychoanalysis*. (p. 167–171). New Brunswick, NJ : Transaction Publishers.
- . (2003). Interviews on Freud and Jung with Henry A. Murray in 1965. *Journal of Analytical Psychology*, 48 (1), 1–27.
- . (2004). *Edoardo Weiss: The house that Freud built*. New Brunswick, NJ: Transaction Publishers.
- . (1969). Victor Tausk's contribution to psychoanalysis. *Psychoanalytic Quarterly*, 38, 349–353.
- Roazen, Paul, and Swerdloff, Bluma. (1995). *Heresy: Sándor Radó's evolution freudienne*. Paris: Payot.
- . (1976). *From Oedipus to Moses: Freud's Jewish identity* (Ralph Manheim, Trans.). Garden City, NY: Anchor Books. (Original work published 1974.)
- Robertson, James. (1953). *A two-year-old goes to hospital*. London: Robertson Centre and Ipswich, Concord Films Council.
- . (1958). *Going to hospital with mother*. London: Robertson Centre and Ipswich, Concord Films Council.
- . (1958). *Young children in hospital*. London: Tavistock Publications.
- . (1976). *Young children in brief separation, series of five*. London, Robertson Centre and Ipswich, Concord Films Council.
- . (1989). *Separation and the very young*. London: Free Association Books.
- Robinson, Forrest. (1992). *Love's story told: A life of Henry A. Murray*. Cambridge, MA: Harvard University Press.
- Robinson, Paul A. (1993). *Freud and his critics*. Berkeley: University of California Press.
- Roch, Marcel (1979). Mademoiselle Madeleine Rambert (1900–1979). *Bulletin de la Société suisse de psychanalyse*, 9, 21–22.
- . (1967). L'œuvre de Charles Odier, médecin et psychanalyste, *Bulletin de la Société suisse de psychanalyse*, 6, 5–7.



- . (1979). Préface: En hommage à Michel Gressot. In Michel Gressot, *Le royaume intermédiaire*. Paris: Presses Universitaires de France.
- . (1980). Á propos de l'histoire de la psychanalyse en Suisse romande. *Bulletin de la Société Suisse de psychanalyse*, 10, 17–30.
- Rodlauer, Hannelore. (1990). *Otto Weiningers Eros und Psyche*. Vienna: Österreich Akademie der Wissenschaften.
- Rodman, F. Robert. (2003). *Winnicott: Life and work*. Cambridge, MA: Perseus Publishing.
- Rodríguez, Rabanal César. (1989). *Cicatrices de la pobreza*. Caracas, Venezuela: Nueva Sociedad.
- Roeder von Diersburg, Egenolf. (1961). Georg Groddeck's Philosophie des Es. *Zeitschrift für philosophische Forschung*, 15, 131–138.
- Rogow, Arnold. (1978). A further note to Freud's "Fragment of an analysis of a case of hysteria. *Journal of the American Psychoanalytic Association*, 26, 311–330.
- Róheim, Géza. (1919). *Spiegelzauber*. Wien: Internationaler Psychoanalytischer Verlag.
- . (1930). *Animism, magic, and the divine king*. London: K. Paul, Trench, Trubner & Co., Ltd.
- . (1932). Psychoanalysis of primitive cultural types. *International Journal of Psychoanalysis*, 13: 2–224.
- . (1934). *The riddle of the sphinx*. London: Hogarth Press
- . (1943). *The origin and function of culture*. New York: Nervous and mental disease monographs 3.
- . (1945). *Eternal ones of the dream: a psychoanalytic interpretation of Australian myth and ritual*. New York: International Universities Press.
- . (1950). *Psychoanalysis and anthropology; Culture, personality and the unconscious*. New York: International Universities Press.
- . (1952). *The gates of the dream*. New York: International Universities Press.
- . (1955). *Magic and schizophrenia*. New York: International Universities Press.
- . (1992). *Fire in the dragon and other psychoanalytic essays on folklore* (Alan Dundes, Ed.). Princeton, NJ: Princeton University Press.
- Roiphe, Herman. (1968). On an early genital phase: with an addendum on genesis. *Psychoanalytic Study of the Child*, 23, 348–368.
- Rolland, Jean-Claude. (1996). Du rêve au mot d'esprit, la fabrique de la langue, *L'inactuel*, 5, 91–105.
- Rolland, Romain. (1959). *The journey within*. New York: Philosophical Library.
- Rorschach, Hermann. (1942). *Psychodiagnostics: A diagnostic test based on perception*. New York: Grune & Stratton.
- . (1965). *Gesammelte Aufsätze*. Bern: H. Huber.
- Rose, Louis. (1986). *The Psychoanalytic Movement in Vienna: Towards a Science of Culture*. Dissertation, Princeton University.
- Rosen, John. (1953). *Direct Analysis*. New York: Grune and Stratton.
- Rosenberg, Benno. (1991). *Masochisme mortifère, Masochisme gardien de la vie*. Paris: Presses Universitaires de France.
- Rosenfeld, David. (1981). *The notion of a psychotic body image in neurotic and psychotic patients*. Finland: Congrès psychanalytique international.
- . (1992). *The psychotic aspects of the personality*. London: Karnac.
- . (1993). Autisme: des aspects autistiques dans la pharmacodépendance et dans les maladies psychosomatiques. *Journal de la psychanalyse de l'enfant*, 20, 168–188.
- Rosenfeld, Herbert. (1949). Remarks on the relation of male homosexuality to paranoia, paranoid anxiety and narcissism. *International Journal of Psychoanalysis*, 30, 36–47.
- . (1950). Note on the psychopathology of confusional states in chronic schizophrenia. *International Journal of Psychoanalysis*, 31, 132–137.
- . (1958). Observations on the psychopathology of hypochondriacal states. *International Journal of Psychoanalysis*, 39, 121–124.
- . (1971). A clinical approach to the psychoanalytic theory of the life and death instincts: an investigation into the aggressive aspects of narcissism. *International Journal of Psychoanalysis*, 52, 169–178.
- . (1985). *Psychotic states: a psychoanalytic approach*. London: Karnac Books. (Original work published 1965)
- Rosenthal, Tatiana. (1920). Stradanje i tvortchestvo v Dostoievskoni. *Voprosy psihologii litschnosti*.
- Rosenzweig, Saul. (1992). *Freud, Jung, and Hall the king-maker: The historic expedition to America (1909)*. St. Louis: Rana House.
- . (1992). *The historic expedition to America (1909: Freud, Jung and Hall the king-maker)*. St. Louis, Rana House.
- Rosolato, Guy. (1964). La différence des sexes. *Essais sur le symbolique*. Paris: Gallimard, 1969.

- . (1967). Étude des perversions sexuelles à partir du fétichisme. In Guy Rosolato, Piera Aulagnier-Spaurani, Jean Clavreul, François Perrier, and Jean-Paul Valabrega (Eds.), *Le désir et la perversion* (pp. 9–52). Paris: Seuil.
- . (1969). *Essais sur le symbolique*. Paris: Gallimard.
- . (1975). L'axe narcissique des dépressions. *La Relation d'inconnu*. Paris: Gallimard.
- . (1978). *La relation d'inconnu*. Paris: Gallimard.
- . (1980). Clérambault et les délires passionnels. *Nouvelle Revue de psychanalyse*, 21, 199–213.
- . (1988). *Le négatif, figures et modalités*. Paris: Dunod.
- . (1993). L'écoute musicale comme méditation. In *Pour une psychanalyse exploratrice de la culture* (pp. 187–197). Paris: Presses Universitaires de France.
- Ross, Helen. (1951). *Fears of children*. Chicago: Science Research Associates.
- Roth, Bennett. (2000). The piano: A modern film melodrama about passion and punishment. *Psychoanalytic Psychology*, 17, 405–413.
- Ross, Helen, and Lewin, Bertram D. (1960). *Psychoanalytic education in the United States*. New York: W. W. Norton.
- Rothe, Hans-Joachim. (1987). *Zur Erinnerung an Karl Landauer. Geb. am 12.10.1887 in München, gest. am 27.1.1945 in Bergen-Belsen*. Frankfurt: Sigmund-Freud-Institut.
- Rothstein, Arnold (Ed.). (1987). *The interpretation of dreams in clinical work*. Madison, CT: International Universities Press.
- . (1988). *How does treatment help? On the modes of therapeutic action of psychoanalytic therapy*. Madison, Ct.: International University Press.
- Rouart, Julien. (1967). Les notions d'investissement et de contre-investissement à travers l'évolution des idées freudiennes. *Revue française de psychanalyse*, 31 (2), 193–213.
- Roudinesco, Élisabeth. (1982). *La bataille de cent ans. Histoire de la psychanalyse en France* (Vol. 1). Paris: Ramsay.
- . (1986). *La bataille de cent ans. Histoire de la psychanalyse en France* (Vol. 2). Paris: Le Seuil, reprinted (Fayard). 1994.
- . (1986). René Laforgue ou la collaboration manquée: Paris–Berlin 1939–1942. *Confrontation*.
- . (1990). *Jacques Lacan & Co.: A history of psychoanalysis in France, 1925–1985*. Jeffrey Mehlman (Trans.). Chicago: University of Chicago Press. (Original work published 1986)
- . (1994). Présentation. In Henri F. Ellenberger, *Histoire de la découverte de l'inconscient*. Paris: Fayard.
- . (1995, Fall). “Georges Mauco, 1899–1988, un psychanalyste au service de Vichy: De l'antisémitisme à la psychopédagogie. *L'infini*, 51, 73–84.
- . (1997). *Jacques Lacan* (Barbara Bray, Trans.). New York: Columbia University Press. (Original work published 1993)
- Roudinesco, Jenny, David, Myriam, Nicolas, J.; et al. (1952). Réactions immédiates des jeunes enfants à la séparation d'avec leur mère. *Courrier du C.I.E.*, 2–3, 66–78, 131–142.
- Roudinesco, Jenny, Trélat, Jean, and Trélat, M. (1949). Étude de quarante cas de dyslexie d'évolution. *Enfance*, 1.
- Rouget, Gilbert. (1980). *La musique et la transe*. Paris: Gallimard.
- Roughton, Ralph. (2002). Rethinking homosexuality: What it teaches us about psychoanalysis. *Journal of the American Psychoanalytic Association*, 50, 733–764.
- Roussillon, René. (1986). Préface, in M. Berger (Ed.): *Entretiens familiaux et champ transitionnel*. Paris: Presses Universitaires de France.
- . (1991). *Paadoxes et situations limites de la psychanalyse*. Paris: Presses Universitaires de France.
- . (1992). *Du baquet de Mesmer au “baquet” de S. Freud*. Paris: Presses Universitaires de France.
- . (1995). La métapsychologie des processus et la transitionnalité. *Revue française de psychanalyse*, 59.
- . (1997). La fonction symbolisante de l'objet. *Revue française de psychanalyse*, 61 (2), 399–413.
- Roustang, François. (1976). *Un destin si funeste*. Paris: Minuit.
- . (1984). Comment devenir un inspire raisonnable. *Philosophie* 3, 47–66.
- . (1990). *Influence*. Paris: Minuit.
- . (1994). *Qu'est-ce que l'hypnose?*. Paris: Minuit.
- Roux, Marie-Lise. (1968). L'Expression verbale du vécu corporel. *Revue française de psychosomatique*, 14.
- Roux, Marie-Lise, Dechaud-Ferbus, Monique, and Sacco, François. (1994). *Les Destins du corps*. Toulouse: Érès.
- Roux, Marie-Lise, et al. (1993). *Le Corps dans la psyche*. Paris: L'Harmattan.
- Rubinstein, B.B. (1996). On the concept of an unconscious wish. *Psychological Issues*, 62, 541–550.
- . (1996). Why metapsychology? *Psychological Issues*, 62, 485–496.

- . (1997). Psychoanalysis and the philosophy of science. In Robert R. Holt (Ed.), *Collected papers of Benjamin B. Rubinstein, M.D.* Madison, CT: International Universities Press.
- Rudhardt, Jean. (1981). La fonction du mythe dans la pensée religieuse de la Grèce. *Revue européenne des sciences sociales*, 19 (58), 177–187.
- Rudnytsky, Peter. (1991). *The psychoanalytic vocation: The legacy of Otto Rank and Donald Winnicott.* New Haven: Yale University Press.
- Rudolf, Gerd. (1987). Vergleich der Akzeptanz psychoanalytischer Konzepte von I.P.A.- und D.P.G.-Mitgliedern.
- Ruiz-Castillo Basala, José. (1972). *El Apasionante mundo del libro. Memorias de un editor.* Madrid: Ediciones de la Revista de Occidente.
- Runyan, William McKinley. (1982). *Life histories and psychobiography. Explorations in theory and method.* New York: Oxford University Press.
- . (1988). *Psychology and historical interpretation.* New York: Oxford University Press.
- Ruyer, Danièle. (1991). Psychanalyse et idéal thérapeutique (interview with Jean Favreau). *Revue Française de Psychanalyse*, 55 (2), 501–509.
- Rycroft, Charles. (1967). *Psychoanalysis observed.* New York: Coward.
- . (1968). *A critical dictionary of psychoanalysis.* London: Nelson.
- . (1968). *Anxiety and neurosis.* London: Allen Lane.
- . (1968). *Imagination and reality.* London: Hogarth Press.
- . (1971). *Wilhelm Reich.* New York: Viking.
- . (1979). *The innocence of dreams.* London: Hogarth Press.
- . (1985). *Psychoanalysis and beyond.* London: Chatto.
- . (1991). *Viewpoints.* London: Hogarth.
- Sánchez Medina, Guillermo. (1991). *Psicoanálisis, ayer, hoy y mañana.* Bogotá: Ed. Gaviota.
- . (1994). *Técnica y clínica psicoanalítica.* Bogotá: Ed. Centro Profesional Gráfico Ltda.
- Sédat, Jacques (Ed.). (1980). *Retour à Lacan?* Paris: Fayard.
- Saada, Denise. (1972). *Sacha Nacht.* Paris, Payot.
- Sabourin, Pierre. (1982). Préface. In Sándor Ferenczi, *Oeuvres Complètes* (Vol. 4). Paris: Payot.
- . (1985). *Ferenczi. Paladin et grand vizir secret.* Paris: Éditions Universitaires.
- Sachs, Hanns. (1924). *Gemeinsame tagträume.* Berlin, Leipzig, and Vienna: Internationaler psychoanalytischer Verlag.
- . (1926). *Psychoanalyse. Rätsel des Unbewussten.* Berlin: Buchdruckerei Lichtbildbühne.
- . (1939). Editorial note. *American Imago*, 1 (1), p. 3
- . (1942). *The creative unconscious: studies in the psychoanalysis of art.* Cambridge, MA: Sci-Arts Publishers.
- . (1948). *Masks of love and life: the philosophical basis of psychoanalysis.* (A. A. Roback, Ed.). Cambridge, MA: Sci-Arts Publishers.
- Sachs, Hanns, and Otto Rank. (1916). *The significance of psychoanalysis for the mental sciences.* (Charles R. Payne, Trans.). New York: Nervous and Mental Disease Publishing Co.
- Sade, Marquis de. (1990). *Justine, philosophy in the bedroom, and other writings.* New York: Grove Press.
- Sadger, Isidor. (1908). Psychiatrisch-Neurologisches in psychanalytischer Beleuchtung. (Psychiatry and neurology in the light of psychoanalysis). *Zentralblatt für das Gesamtgebiet der Medizin und ihrer Hilfswissenschaften*, 7–8.
- . (1910). Ein fall von multipler perversion. (A case of multiple perversion). *Jahrbuch für psychoanalytische und psychopathologische Forschungen*, 2.
- . (1921). *Die lehre von den geschlechtsverirrungen (Psychopathia sexualis), auf psychoanalytischer grundlage.* Leipzig-Vienna: F. Deuticke.
- Safouan, Mustapha. (1988). Désir et mot d'esprit. *Apertura*, 2, 93–97.
- Sagawa, Roberto Yutaka. (1980). Durval Marcondes e o início do movimento psicanalítico brasileiro. *Cader-nos Freud-Lacan*, 2.
- . (1996). *A construção local da psicanálise.* Marília, Brazil: Interior-Psicanálise.
- Sajner, Josef. (1968). Sigmund Freuds Beziehungen zu seinem Geburtsort Freiberg (Pribor), und zu Mähren. *Clio Medica*, 3, p. 167–180.
- Sameroff, Arnold J., and Emde, Robert N. (Eds.). (1989). *Relationship disturbances in early childhood: a developmental approach.* New York: Basic Books.
- Sami, Ali M. (1970). *De la projection. Une étude psychanalytique.* Paris: Payot.
- Sampson, Harold. (1992). A new psychoanalytic theory and its testing in formal research. In James W. Barron, Morris N. Eagle and David L. Wolitzky (Eds.), *Interface of psychoanalysis and psychology* (pp. 586–

- 604). Washington, D.C.: American Psychological Association.
- Samuels, Andrew. (1985). *Jung and the Post-Jungians*. London-Boston: Routledge.
- . (1986). A critical dictionary of Jungian analysis. London: Routledge.
- . (1993). *The political psyche*. London and New York: Routledge.
- . (1994, April). The professionalization of Carl G. Jung's Analytical Psychology Clubs. *Journal of the Historical and Behavioral Sciences*, XXX, 138–147.
- Sanchez-Medina, Guillermo. (1998). Sesenta años de psicoanálisis en Latinoamérica. *Homepage Federación psicoanalítica de América latina*.
- Sander, Fred. (1979). *Individual and family therapy: Toward an integration*. New York: Aronson.
- Sander, Louis W. (1964). Adaptive relationships in early mother-child interaction. *Journal of the American Academy of Child Psychiatry*, 3, 231–64.
- Sandler, Joseph. (1960). On the concept of the super-ego. *Psychoanalytical Study of Children*, 15, 128–162.
- . (1976). Counter-transference and role-responsiveness. *International Review of Psycho-Analysis*, 3, 43–47.
- . (1976). Dreams, unconscious phantasies and “identity of perception.” *International Review of Psychoanalysis*, 3, p. 33–42.
- . (1985). *The analysis of defense: the ego and the mechanisms of defense revisited*. New York: International Universities Press.
- . (1988). *From safety to superego*. New York, London: Karnac Books International Universities Press.
- . (1990). The structure of internal objects and internal object relations. *Psychoanalytical Inquiry*, 10, 163–181.
- . (1993). On communication from patient to analyst: not everything is projective identification. *International Journal of Psychoanalysis*, 74, 1097–1108.
- Sandler, Joseph. (Ed.). (1986). *Projection, identification, projective identification*. Madison, CT: International Universities Press.
- . (1988). *Projection, identification, projective identification*. London: Karnac Books.
- Sandler, Joseph, and Sandler, Anne-Marie. (1987). Past unconscious, present unconscious, and the vicissitudes of guilt. *International Journal Psychoanalysis*, 68, 331–342.
- . (1994). Theoretical, technical comments on regression and anti-regression. *International Journal of Psychoanalysis*, 75, 431–440.
- . (1998). *Internal objects revisited*. London: Karnac Books.
- Sandler, Joseph; Dare, Christopher, and Holder, Alex. (1997). *The patient and the analyst: the basis of the psychoanalytic process*. New York: International Universities Press.
- Sandler, Joseph, et al. (1991). Conceptual research in psychoanalysis: psychic trauma. *International Review of Psychoanalysis*, 18, 133–142.
- . (1991). Freud's “On Narcissism: An Introduction.” International Psychoanalytical Association, New Haven and London: Yale University Press.
- Sandler, Joseph, Kennedy, Hansi, and Tyson, Robert L. (1980). *The technique of child analysis. Discussions with Anna Freud*. London: Hogarth and the Institute of Psychoanalysis.
- Santiago, Virgilio. (1966). Psychopathology of Sisa. *Acta Medica Philippina*, 2 (3), 140–145.
- Sarasin, Philipp. (1929). Goethes Mignon. Eine psychoanalytische Studie *Imago*, 15.
- . (1966). Meine richtlinien. *Bulletin der Schweizerischen Gesellschaft für psychanalyse*, 3, p. 1.
- . (1968). Wie ich zu Freud kam. *Bulletin der Schweizerischen Gesellschaft für psychanalyse*, Sommer 1968, pp. 1–2.
- Sarlin, Charles N. (1981). The role of breast feeding in psychosexual development and the achievement of the genital phase. *Journal of the American Psychoanalytic Association*, 29, 631–642.
- Sarnoff, Charles. (1976). *Latency*. New York: Jason Aronson.
- . (1987). *Psychotherapeutic strategies in late latency through early adolescence*, Northvale, NJ: Aronson.
- . (1990). *Psychic Envelopes*. (Daphne Briggs, Trans.). London: Karnac Books.
- Sartre, Jean Paul. (1960). *Critique de la raison dialectique*. Paris: Gallimard.
- . (1963). *Saint Genet, actor and martyr*. (Bernard Frechtman, Trans.). New York: G. Braziller. (Original work published 1952)
- . (1964). *Being and nothingness; an essay in phenomenological ontology*. Special abridged ed. New York: Citadel Press. (Original work published 1943)
- . (1972). *The transcendence of the ego: an existentialist theory of consciousness*. New York: Octagon Books. (Original work published 1936–1937)

- Sartre, Jean Paul. (1948). *The psychology of imagination*. Secaucus, NJ: Citadel Press. (Original work published 1940)
- . (1976). *Critique of dialectical reason, theory of practical ensembles*. (Jonathan Rée, Ed.; Alan Sheridan-Smith, Trans.). London: NLB; Atlantic Highlands, NJ: Humanities Press. (Original work published 1960)
- . (1981). *The family idiot: Gustave Flaubert, 1821–1857*. (Carol Cosman, Trans.). Chicago: University of Chicago Press. (Original work published 1971–1972)
- . (1985). *The Freud scenario* (Quinton Hoare, Trans.). London: Verso. (Original work published 1984)
- Sass, L. A., and Woolfolk, R. L. (1988). Psychoanalysis and the hermeneutic turn: on “Narrative truth.” *Journal of the American Psychoanalytic Association*, 36, 429–454.
- Sauguet, Henri. (1966). Caractère et nevrose. *Revue française de psychanalyse*, 30 (3), 298–307.
- Saul, Leon J. (1966). Embarrassment dreams of nakedness. *International Journal of Psychoanalysis*, 47 (4), 552–58.
- Saussure, Ferdinand de. (1986). *Course in general linguistics* (Roy Harris, Trans.). LaSalle, IL: Open Court. (Original work published 1915)
- Saussure, Raymond de. (1929). Les fixations homosexuelles chez les femmes névrosées. *Revue française de psychanalyse*, 3, 50–91.
- . (1939). *Le miracle grec*. Paris: Denoël.
- . (1959). The metapsychology of pleasure. *International Journal of Psychoanalysis*, 22, 649–674.
- . (1967–1968). L’histoire de la psychanalyse en Suisse romande. *Bulletin de la Société suisse de psychanalyse*, 6, 1–4.
- Sauvagnat, François (Ed.). (1992). Les coordonnées historiques de la distinction acting-out / passage à l’acte. In *Le souci de l’être: Le soin en psychiatrie*. Paris: GRAPP-Le Seuil.
- Schachter, Judith, and Luborsky, Lester. (1998). Who’s afraid of psychoanalytic research? *International Journal of Psychoanalysis*, 79, 965–970.
- Schaeffer, Jacqueline. (1986). Le rubis a horreur du rouge. Relation et contre-investissement hystériques. *Revue française de psychanalyse*, 50 (3), 923–944.
- . (1997). *Le refus du féminin*. Paris: Presses Universitaires de France.
- Schafer, Roy. (1967). *Projective testing and psychoanalysis: Selected papers*. New York: International Universities Press.
- . (1976). *A new language for psychoanalysis*. New Haven, CT: Yale University Press.
- . (1978). *Language and insight*. New Haven, CT: Yale University Press.
- . (1980). Action language and the psychology of the self. *Annual of Psychoanalysis* (Chicago Institute), 8, 83–92.
- . (1983). *The analytic attitude*. London: Hogarth.
- . (1988). Discussion of panel presentations on psychic structure. *Journal of the American Psychoanalytic Association*, 36(S), 295–312.
- . (1992). Retelling a life. *Narration and dialogue in psychoanalysis*. New York: Basic Books.
- Schapiro, Meyer. (1994). *Theory and philosophy of art: style, artist, and society*. New York: George Braziller.
- Scharff, Jill S. (1992). *Projective and introjective identification and the use of the therapist’s self*. Northvale, NJ: Jason Aronson.
- Scharff, Jill S., and Scharff, David E. (1994). *Object relations therapy of physical and sexual trauma*. Northvale, NJ: Aronson, Inc.
- Schiferer, H. Rüdiger, Gröger, Helmut, and Skopec, Manfred. (1995). *Alfred Adler: eine Bildbiographie. Mit bisher unbekanntem Original-Dokumenten und zum grössten Teil unveröffentlichten Abbildungen*. Munich-Basel: Ernst Reinhardt.
- Schiff, Paul, and Antheaume, André. (1925, July). La psychanalyse envisagée du point de vue de quelques applications médico-légales. *Encéphale* (July 1925): 400.
- Schiff, Paul. (1935). Les paranoïas et la psychanalyse. *Revue française de psychanalyse*, 8, 44–105.
- . (1946). La paranoïa de destruction: Réaction de Samson et fantasme de la fin du monde, séance du 25 mars 1946. *Annales Médico-Psychologiques*, 1, 3, 279–289.
- Schilder, Paul. (1925). *Entwurf zu einer psychiatrie auf psychoanalytischer grundlage*. Leipzig, Vienne, Zürich: Internationaler Psychoanalytischer Verlag.
- . (1935). *The image and appearance of the human body*. London: Kegan Paul, Trench, Trubner.
- . (1951). Studies concerning the psychology and symptomatology of general paresis. In David Rapaport (Ed.), *Organization and pathology of thought*. New York: Columbia University Press. (Original work published 1930)
- . (1953). *Medical psychology* (David Rapaport, Trans.). New York: International Universities Press. (Original work published 1924)

- Schjelderup, Harald K. (1957). Lasting effects of psychoanalytic treatment. *Psychiatry*, 18, 109–133.
- Schlossmann, A. (1919). Nachruf auf Adolf Baginsky. *Arch. Kinderheilkunde*, 67, 1–6.
- Schlumberger, Marc. (1936). Sur la guérison d'un cas d'impuissance. *Revue française de psychanalyse*, 9, 4, 589–605.
- . (1952). Introduction à l'étude du transfert en clinique psychanalytique. XIVth Congress of French-Speaking Psychoanalysts, Paris, 1951. *Revue française de psychanalyse*, 16, 1–2, 123–169.
- . (1959). Expression du transfert dans les rêves. *Revue française de psychanalyse*, 23, 3, 381–392.
- Schlumberger, Marc, Benassy, Maurice, and Lebovici, Serge. (1958). Sur l'utilisation du matériel onirique en thérapie psychanalytique chez l'adulte. Introduction. Colloque de la S.P.P., Paris, 1958. *Revue française de psychanalyse*, 23, 1, 7–27.
- Schmideberg, Melitta. (1930). Psychotic mechanisms in relation to the development of civilisation. *International Journal of Psychoanalysis*, 11, 387–418.
- . (1935). The psycho-analysis of asocial children and adolescents. *International Journal of Psychoanalysis*, 16, 22–48.
- . (1938). After the analysis. . . some phantasies of patients. *Psychoanalytic Quarterly*, 7, 122–142.
- . (1991). Paper read at the second Extraordinary Business Meeting. In P.H.M. King, R. Steiner (Eds.), *The Freud-Klein controversies 1941–1945*. London: Institute of Psycho-Analysis-Routledge, p. 92–99. (Original work published 1942)
- Schmidt, Vera. (1920–22). Le Journal de Volik (unpublished).
- Schmit, Gérard, and Soulé, Michel. (1985). L'énurésie infantile. In Serge Lebovici, René Diatkine, and Michel Soulé (Eds.), *Nouveau traité de psychiatrie de l'enfant et l'adolescent* (pp. 1751–1770). Paris: Presses Universitaires de France.
- Schneider, Ernst. (1929). Psychoanalyse und lehrerbildung. *Zeitschrift für psychoanalytische Pädagogik.*, 3, 237–251.
- Schneider, Monique. (1989). Philosophes après Freud. *L'univers philosophique: Encyclopédie philosophique universelle* (pp. 720–731). Paris: Presses Universitaires de France.
- . (1992). *La part de l'ombre. Approche d'un trauma féminin*. Paris: Aubier.
- Schneider, Pierre-Bernard. (1965–1972). *Pratique de la psychothérapie de groupe*. Paris: Presses Universitaires de France.
- Scholz Strasser, Inge. Newsletter. *Sigmund Freud House Bulletin* 1991, 15 (1), 40–48.
- Schopenhauer, Arthur. (2000). Die Transzendente Spekulation über die anscheinende Absichtlichkeit im Schicksal des Einzelnen In *Parerga and paralipomena: short philosophical essays* (E. F. J. Payne, Trans.). New York: Oxford University Press. (Original work published 1851.)
- Schopp, Georges. (1990). “L'affaire Clark-Williams ou la question de l'analyse laïque en France.” *Revue internationale d'histoire de la psychanalyse*, 3, 199–239.
- Schott, Heinz G. (1981). “Traumdeutung” und “infantile Cerebrallähmung.” Überlegungen zu Freuds Theoriebildung. *Psyche*, 35, 97–110.
- Schotte, Jacques. (1990). *Szondi avec Freud: sur la voie d'une psychiatrie pulsionnelle*. Bruxelles: De Boeck-Université.
- Schröter, Michael. (1995). Freuds Komitee, 1912–1914: Ein Beitrag zum Verständnis psychoanalytischer Gruppenbildung. *Psyche*, 49, 513–563.
- . (2003). Fliess versus Weininger, Swoboda, and Freud: the plagiarism conflict of 1906 assessed in the light of the documents. *Psychoanalysis and History*, 5, 2, 147–173.
- Schröter, Michael and Hermanns, Ludger. (1992). Felix Gattel, 1870–1904: Freud's first pupil. *International Review of Psychoanalysis*, 19, 91–104, 97–208.
- Schreber, Daniel Paul. (1988). *Memoirs of my nervous illness*. (I. Macalpine, R. Hunter, Trans.). Cambridge: Harvard University Press. (Original work published 1903)
- Schuker, Eleanor, and Levinson, Nadine. (1991). *Female psychology: An annotated psychoanalytic bibliography*. Hillsdale, NJ/London: The Analytic Press.
- Schultz-Hencke, Harald. (1931). *Schicksal und neurose*. Jena: S. Fischer.
- . (1951). *Lehrbuch der analytischen psychotherapie*. Thieme.
- . (1972). *Einführung in die psychoanalyse*. Jena-Göttingen: Fischer-Vandenhoeck and Ruprecht. (Original work published 1927)
- . (1982). *Der gehemmte mensch*. Leipzig, Stuttgart: Thieme. (Original work published 1940)
- Schultz-Venrath, Ulrich. (1995). *Ernst Simmels psychoanalytische Klinik Sanatorium Schloss Tegel GmbH (1927–1931)*. Frankfurt am Main-Washington: Deutsche Hochschulschriften 2081, Mikroedition.
- Schulz, Manfred. (1981). Dr. John Rittmeister, Nervenarzt und Widerstandskämpfer. Medical dissertation, Humboldt University, Berlin.

- Schur, Max. (1953). The ego in anxiety. In R. M. Loewenstein (Ed.), *Drives, affects, behavior. Essays in memory of Marie Bonaparte*. (p. 67–103). New York: International Universities Press.
- . (1955). Comments on the metapsychology of somatization. *Psychoanalytic Study of the Child*, 10, 119–164.
- . (1958). The ego and the id in anxiety. *Psychoanalytic Study of the Child*, 13, 190–220.
- . (1962). The theory of the infant-parent relationship. *International Journal of Psychoanalysis*, 43, 243–245.
- . (1966). Some additional “day residues” of “the specimen dream of psychoanalysis.” In R. M. Loewenstein, L. M. Newman, M. Schur, and A. J. Solnit (Eds.), *Psychoanalysis: a general psychology*. New York: International Universities Press.
- . (1969). The background of Freud’s disturbance on the acropolis. *American Imago*, 26, 303–323.
- . (1972). *Freud: living and dying*. New York: International Universities Press.
- Schur, Max, and Ritvo, Lucille B. (1970). The concept of development and evolution in psychoanalysis. In Lester R. Aronson et al. (Eds.), *Development and evolution of behavior*. San Francisco: W. H. Freeman.
- Schwaber, Evelyn. (1977). Understanding unfolding “narcissistic transference.” *International Review of Psychoanalysis*, 4, 493–502.
- . (1981). Empathy: a mode of analytic listening. *Psychoanalytical Inquiry*, 1, 357–392.
- Schwartz, Charlotte (1989). Ambivalence: relation to narcissism and superego development. *Psychoanalytic Review*, 76, 511–527.
- Schwartz, Murray and Kahn, Copelia. (1980). *Representing Shakespeare*. Baltimore: Johns Hopkins University.
- Scott, Clifford. (1946). A note on the psychopathology of convulsive phenomena in manic-depressive states. *International Journal of Psychoanalysis*, 27, 162–155.
- Searles, Harold F. (1960). *The nonhuman environment in normal development and schizophrenia*. New York: International University Press;
- . (1962). The differentiation between concrete and metaphorical thinking in the recovering schizophrenic patient. *Journal of the American Psychoanalytic Association*, 10 (1), 22–49.
- . (1965). *Collected papers on schizophrenia and related subjects*. New York: International Universities Press.
- . (1979). *Countertransference and related subjects*. New York: International University Press.
- . (1986). *My work with borderline patients*. Northvale, NJ: Aronson.
- Šebek, Michael. (1992). La psychanalyse, les psychanalystes et la période stalinienne de l’après-guerre. La situation tchécoslovaque. *Revue internationale d’histoire de la psychanalyse*, 5, 553–568.
- . (1993). Psychoanalysis in Czechoslovakia. *Psychoanalytic Review*, 80 (3), 433–439.
- Sechehaye, Marguerite A. (1951). *Autobiography of a schizophrenic girl; with analytic interpretation by Marguerite Sechehaye*. (Grace Rubin-Rabson, Trans.). New York: Grune and Stratton.
- . (1954). *Introduction à la psychothérapie des schizophrènes*. Paris: Presses Universitaires de France.
- . (1956). *A new psychotherapy in schizophrenia: Relief of frustrations by symbolic realization*. New York: Grune and Stratton.
- . (1957). La réalisation symbolique, un catalyseur de la structuration du moi schizophrène. *Acta psychotherapeutica, psychosomatica et orthopedagogica*. Basel.
- . (1970). *Symbolic realization; a new method of psychotherapy applied to a case of schizophrenia*. (Barbrö Würsten and Helmut Würsten, Trans.). New York: International Universities Press. (Original work published 1947)
- Second, Pierre. (1993). Eva Freud, une vie: Berlin 1924, Nice 1934, Marseille 1944. *Trames*, 75, 16.
- Segal, Hanna. (1950). Some aspects of the analysis of a schizophrenic. *International Journal of Psychoanalysis*, 31, 268–278.
- . (1952). A psycho-analytic contribution to aesthetics. *International Journal of Psychoanalysis*, 33, 196–207; Klein, Heimann and Money-Kyrle (Eds.). (1955). *New directions in psycho-analysis*. London : Tavistock Publications, p. 384–407.
- . (1956). Depression in the schizophrenic. *International Journal of Psychoanalysis*, 37, 339–343.
- . (1957). Notes on symbol formation. *International Journal of Psychoanalysis*, 38, 391–397.
- . (1978). On symbolism. *International Journal of Psychoanalysis*, 59, 303–314.
- . (1979). *Melanie Klein*. New York: Viking Press.
- . (1981). Countertransference. In *The work of Hanna Segal*. New York: Jason Aronson.
- . (1984). Joseph Conrad and the mid-life crisis. *International Review of Psychoanalysis*, 11, 3–10.

- . (1988). *Introduction to the work of Melanie Klein*. London: Karnac Books.
- . (1991). *Dreams, phantasy, and art*. London: Routledge and the Institute of Psycho-Analysis.
- . (1993). Review of *A dictionary of Kleinian thought*. *International Journal of Psychoanalysis*, 74, 417–419.
- . (1999). Le complexe d'Oedipe aujourd'hui. *Journal de la psychanalyse de l'enfant*, 24, 155–161.
- Segal, Hanna, and Steiner, Riccardo. (1987). H.A. Rosenfeld. *International Journal of Psychoanalysis*, 68, 415–419.
- Sellier, Philippe. (1970). *Le mythe du héros*. Paris: Bordas.
- Selvini-Palazzoli, Mara; Boscolo, Luigi; Cecchin, Gianfranco; et al. (1975). *Paradox and counterparadox: a new model in the therapy of the family in schizophrenic transaction*. (Elisabeth V. Burt, Trans.). New York: J. Aronson.
- Sengoopta, Chandak. (2000). *Otto Weininger: Sex, science, and self in imperial Vienna*. Chicago: University of Chicago Press.
- Servadio, Emilio. (1935). Psychoanalyse und Telepathie. *Imago*, 23, pp. 489–497.
- . (1955). A presumptively telepathic precognitive dream during analysis. *International Journal of Psychoanalysis*, 36, pp. 27–30.
- Seulin, Christian. (1997). Le temps figé des rêves récurrents. *Bulletin de la Société de psychanalyse de Paris*, 4, April 1997: 91–99..
- Shamdasani, Sonu. (1990). A woman called Frank. *Spring*, 50
- Shapiro, David. (1999). *Neurotic styles*. New York: Basic.
- Shapiro, Kenneth, and Alexander, Irving. (1975). *The Experience of Introversion*. Durham, NC: Duke University Press.
- Shapiro, Sue A. (1981). *Contemporary theories of schizophrenia: Review and synthesis*. New York: McGraw-Hill.
- . (1993). Clara Thompson, Ferenczi's messenger with half a message. In L. Aron and A. Harris (Eds.), *Legacy of Sándor Ferenczi*. Hillsdale/N.J.-London: The Analytic Press.
- Shapiro, Theodore. (1981). Empathy: a critical re-evaluation. *Psychoanalytical Inquiry*, 1, 423–448.
- . (1988). Language structure and psychoanalysis. *Journal of the American Psychoanalytic Association*, 36(S), 339–358.
- Shapiro, Theodore, and Emde, Robert N. Ed (1995). *Research in psychoanalysis: Process, development, outcome*. Madison, CT: International University Press.
- Sharaf, Myron R. (1983). *Fury on Earth: A biography of Wilhelm Reich*. New York: St. Martin's Press.
- Sharpe, Ella F. (1930). The technique of psycho-analysis. Seven lectures. *International Journal of Psychoanalysis*, 11, 251–277; 12, 24–60.
- . (1935). Similar and divergent unconscious determinants underlying the sublimations of pure art and pure science. *International Journal of Psychoanalysis*, 16, 180–202.
- . (1937). *Dream analysis: a practical handbook for psychoanalysts*. London: Hogarth and the Institute for Psycho-Analysis.
- . (1940). Psycho-physical problems revealed in language: an examination of metaphor. *International Journal of Psychoanalysis*, 21, 201–213.
- . (1950). *Collected papers on psycho-analysis*. (M. Brierley, Ed.). International Psycho-Analytical Library, vol. 29. London: Hogarth and the Institute for Psycho-Analysis,
- Shaughnessy, Patrick. (1995). Empathy, working alliance: Mistranslation Freud's "einfuhling." *Psychoanalytical Psychology*, 12, 221–232.
- Shengold, Leonard. (1974). The metaphor of the mirror. *Journal of the American Psychoanalytic Association*, 22, 97–115.
- . (1985). Defensive anality and anal narcissism. *International Journal of Psychoanalysis*, 66, 47–74.
- . (1989). *Soul murder: the effects of childhood abuse and deprivation*. New Haven: Yale University Press.
- Shentoub, Salem A. (1984). De la Machine à influencer à la suggestion. In *L'Impact de la suggestion dans la pratique psychanalytique*. Paris: Institut Psychanalytique de Paris.
- Shentoub, Salem A., and Soulairac, André. (1961). L'enfant automutilateur. *Psychiatrie de l'enfant*, 3, 111–145.
- Shentoub, Salem A. et al. (1989). *L'Humour dans l'oeuvre de Freud*. Paris: Two Cities.
- Sherkow, Susan. (2002). The analysis of a pre-adolescent girl with primal scene fantasies. *Psychoanalytic Study of the Child*, 57, 327–354.
- Shevrin, Howard. (1995). Psychoanalysis: one science, two sciences, or no science?. *Journal of the American Psychoanalytic Association*, 43, 963–985.



- Shulman, Michael E. (1987). On the problem of the id in psychoanalytic theory. *International Journal of Psychoanalysis*, 68, 161–174.
- Siboni, Jacques. (1996). *Les mathèmes de Lacan: Anthologie des assertions entièrement transmissibles et de leurs relations dans les écrits de Jacques Lacan*. Paris: Lysimaque.
- Sigmund Freud Museum (Ed.). (1995). *Internationaler psychoanalytischer Verlag, 1919–1938*. Vienna: Sigmund Freud Museum.
- Silberer, Herbert. (1911). Symbolik des Erwachens und Schwellensymbolik überhaupt. *Jahrbuch für psychoanalytische und psychopathologische Forschungen*, 3, 621–660.
- . (1917). *Problems of mysticism and its symbolism*. New York: Moffat, Yard.
- . (1951). Report on a method of eliciting and observing certain symbolic hallucination-phenomena. In David Rapaport (Ed.), *Organization and pathology of thought: selected sources* (pp. 195–207). New York: Columbia University Press. (Original work published 1909)
- . (1971). *Hidden symbolism of alchemy and the occult arts* (Smith Ely Jelliffe, Trans.). New York: Dover. (Original work published 1914.)
- Silberschatz, G., Fretter, P., and Curtis, J. (1986). How do interpretations influence the process of psychotherapy? *Journal of Consulting and Clinical Psychology*, 54, 646–652.
- Silverman, Doris K. (2003). Theorizing in the shadow of Foucault: facets of female sexuality. *Psychoanalytic Dialogues*, 13, 243–258.
- Silverman, Martin. (2002). The will to succeed and the capacity to do so: the power of positive identifications. *Psychoanalytic Quarterly*, 71, 777–800.
- Silverstein, Barry. (1985). Freud's psychology and its organic foundation: Sexuality and mind-body interactionism. *Psychoanalytic Review*, 72, 199–228; 203–228.
- Simmel, Ernst. (1921). *On the psychoanalysis and the war neuroses*. London: International Psychoanalytic Press.
- . (1931). Über die Psychogenese von Organstörungen und ihre psychoanalytische Behandlung. In *Report on the sixth general medical congress for psychotherapy* (p. 56–65; 251–260). Leipzig: Hirzel.
- . (1937). The psychoanalytic sanitarium and the psychoanalytic movement. *Bulletin of the Menninger Clinic*, 1, 133–143.
- . (1944). Self-preservation and the death instinct. *Psychoanalytic Quarterly*, 13, 160–185.
- . (1946). *Anti-Semitism. A social disease*. New York: International Universities Press.
- . (1949). Incendiarism. In K. R. Eissler (Ed.): *Searchlights on Delinquency. New Psychoanalytic Studies Dedicated to Prof. Aichhorn on the Occasion of His 70th Birthday July 1948*. New York, International Universities Press, 90–101; repr. *Yearbook of Psychoanalysis*, 5, 269–274.
- . (1990). Neurotische Kriminalität und Lustmord. Eingeleitet und kommentiert von Schultz U., Hermanns L.M., Küttemeyer M.: die psychoanalytische Behandlung einer Lustmörderin im Jahre 1930. *Psyche*, 44, 71–99.
- . (1993). *Psychoanalyse und ihre Anwendungen*. Frankfurt-am-Main: S. Fischer.
- Simon, Bennett. (1986). Power of the wish and the wish for power. *Psychoanalytic Inquiry*, 6, 119–132.
- . (1988). The imaginary twins: the case of Beckett and Bion. *International Review of Psychoanalysis*, 15, 331–352.
- . (1991). Is the oedipus complex still the cornerstone of psychoanalysis?. *Journal of the American Psychoanalytic Association*, 39, 641–668.
- . (1992). Incest—see under oedipus complex”: the history of an error in psychoanalysis. *Journal of the American Psychoanalytic Association*, 40, 955–988.
- Simon, Bennett, and Bullock, Christopher. (1994). Incest and psychoanalysis: Are we ready to fully acknowledge, bear and understand? *Journal of the American Psychoanalytic Association*, 42, 1261–1282.
- Sinelnikoff, Constantin. (1970). *L'Œuvre de Wilhelm Reich*. Paris, Maspero.
- Siskind, Diana. (1994). Arrests of psychosexual development and separation-individuation. *Psychoanalytical Inquiry*, 14, 58–82.
- Slade, Arietta. (1999). Representation, symbolization, affect regulation between mother and child. *Psychoanalytical Inquiry*, 19, 797–830.
- Slochower, Harry. (1967). George B. Wilbur at 80. *American Imago*, 24, 4, 287–289.
- Slochower, Harry, and Schupper, Fabian X. (1967). George Wilbur at 80. *American Imago*, Vol. 24, No. 4, pp. 287–89.
- Smadja, Claude. (1993). À propos des procédés auto-calmandants du Moi. *Revue française de psychosomatique* 4, 9–26.
- . (1999). Le fonctionnement opératoire dans la pratique psychosomatique: LVIIIe Congrès des psychanalystes de langue française des pays romans à Lausanne. *Revue française de psychanalyse*, 63 (6), 1367–1440.

- Smirnoff, Victor. (1971 [1966]). *The scope of child analysis*. (Stephen Corrin, Trans.). New York: International Universities Press.
- . (1977, April). Intervention. *Documents et Débats*, 13, 17–22.
- . (1978). “... Et mourir de plaisir.” *Nouvelle Revue de psychanalyse*, 17, 139–167.
- . (1979). De Vienne à Paris. Sur les origines d’une psychanalyse à la française. *Nouvelle Revue de psychanalyse*, 20, 13–59.
- . (1994). Autopresentation. In L. M. Hermanns (Ed.), *Psychoanalyse in Selbstdarstellungen*, vol. 2. Sonderdr. Tübingen: Diskord.
- Smith, Henry F. (1997). Resistance, enactment, and interpretation: a self-analytic study. *Psychoanalytic Inquiry*, 17, 13–30.
- . (1999). Subjectivity and objectivity in analytic listening. *Journal of the American Psychoanalytic Association*, 47, 465–484.
- . (2000). Countertransference, conflictual listening and the analytic object. *Journal of the American Psychoanalytic Association*, 48, 95–128.
- . (2001). Hearing voices: the fate of the analyst’s identifications. *Journal of the American Psychoanalytic Association*, 49, 781–812.
- . (2003). Conceptions of conflict in psychoanalytic theory and practice. *Psychoanalytic Quarterly*, 72, 49–96.
- Smith, Joseph, and Humphrey, Morris (Eds.). (1992). *Telling facts: history and narration in psychoanalysis*. Baltimore: Johns Hopkins University Press.
- Smith, Maurice Hamblin. (1924). An interesting dream. *International Journal of Psychoanalysis*, 5, 4, 468–446.
- Smith, William Robertson. (1889). *Lectures on the religion of the Semites*. New York: Schocken Books, 1972.
- Socarides, Charles W. (1978). *Homosexuality*. New York: Jason Aronson.
- Société psychanalytique de Montréal. (1992). *Bulletin de la SPM*.
- . (1994). *Bulletin de la SPM*.
- Sokolnicka, Eugénie. (1920). Analysis of an obsessional neurosis in a child. *International Journal of Psychoanalysis*, 3, 306–319.
- . (1929). Quelques problèmes de technique psychoanalytique. *Revue française de psychanalyse*, 3 (1), 1–91.
- Solms-Rödelheim, Wilhelm. (1976). Psychoanalyse in Österreich. In D. Eicke (ed.), *Tiefenpsychologie*. Beltz-Weinheim-Basle: Die psychoanalytische Bewegung, 1982.
- Soulé, Michel. (1982). L’enfant imaginaire: fantasme d’enfant, le désir d’enfant, le désir de grossesse. In *La Dynamique du nourrisson*. Paris: E.S.F.
- . (1992). *Introduction à la psychiatrie foetale*. Paris: E. S. F.
- Soulé, Michel, and Lebovici, Serge. (2003). La connaissance de l’enfant par la psychanalyse. Paris, Presses Universitaires de France.
- Soulé, Michel, et al. (1995). Les troubles de la defecation. In S. Lebovici, R. Diatkine, and M. Soulé (Eds.). *Nouveau traité de psychiatrie de l’enfant et de l’adolescent* (Vol. 4, pp. 2679–2700). Paris: Presses Universitaires de France.
- Soulé, Michel, Lauzanne, Kathlen, and Leblanc, Nelly. (1995). La carence de soins maternels. In Serge Lebovici, René Diatkine, and Michel Soulé (Eds.). *Nouveau traité de psychiatrie de l’enfant et de l’adolescent* (Vol. 4, pp. 2529–2545). Paris: Presses Universitaires de France.
- Sourkes, Theodore L., and Pinard, Gilbert (Eds.). (1995). *Building on a Proud Past: 50 Years of Psychiatry at McGill*. Montreal: McGill University.
- Sours, John. (1980). *Starving to death in a sea of objects: the anorexia nervosa syndrome*. New York: Jason Aronson.
- Spehlmann, Rainer. (1953). *Sigmund Freuds neurologische Schriften*. Berlin-Heidelberg-Göttingen.
- Spence, Donald P. (1982). *Narrative truth and historical truth. Meaning and interpretation in psychoanalysis*. New York: W. W. Norton and Co.
- . (1982). Some clinical implications of action language. *Journal of the American Psychoanalytic Association*, 30, 169–184.
- Spensley, Sheila. (1995). *Frances Tustin*. London: Routledge.
- Sperber, Hans. (1912). Über den Einfluss sexueller Momente auf Entstehung und Entwicklung der Sprache. *Imago*, 1 (5), 405–453.
- Sperling, Melitta. (1946). Psychoanalytic study of ulcerative colitis in children. *Psychoanalytic Quarterly*, 15 (3), 302–329.
- . (1957). The psychoanalytic treatment of ulcerative colitis. *International Journal of Psychoanalysis*, 38, 341–349.
- . (1958). Pavor nocturnus. *Journal of the American Psychoanalytic Association*, 1, 79–94.
- . (1963). Fetishism in children. *Psychoanalytic Quarterly*, 32, 374–392.

- Spezzano, Charles. (1993). A relational model of inquiry and truth: conversation. *Psychoanalytic Dialogues*, 3, 177–208.
- Spiegel, Leo. (1978). Moral masochism. *Psychoanalytic Quarterly*, 47, 209–236.
- Spielrein, Sabina. (1995). Destruction as a cause of coming into being (S. K. Witt, Trans.). *Psychoanalysis and Contemporary Thought*, 18, 85–118. (Original work published 1911)
- Spillius, Elisabeth. (1988). *Melanie Klein today*. London, Routledge.
- Spinoza, Benedictus de. (2000). *Ethics* (G. H. R. Parkinson, Trans.). New York: Oxford University Press.
- Spiro, Melford. (1982). *Oedipus in the Trobriands*. Chicago: University of Chicago Press.
- Spitz, Ellen Handler. (1998). Martha Wolfenstein: Toward the severance of memory from hope. *Psychoanalytic Review*, 85, 105–115.
- Spitz, René A. (1945). Hospitalism: An inquiry into the genesis of psychiatric conditions in early childhood. *Psychoanalytic Study of the Child*, 1, 53–74.
- . (1946). Anaclitic depression. *Psychoanalytic Study of the Child*, 2, 313–342.
- . (1946). Hospitalism: a follow-up report. *Psychoanalytic Study of the Child*, 2, 113–118.
- . (1950). Anxiety in infancy. *International Journal of Psychoanalysis*, 31.
- . (1950). Relevancy of direct infant observation. *Psychoanalytic Study of the Child*, 5, 66–73.
- . (1955). The primal cavity: A contribution to the genesis of perception. *Psychoanalytic Study of the Child*, 10, 215–40.
- . (1957). *No and yes: on the genesis of human communication*. New York: International Universities Press.
- . (1958). On the genesis of superego components. *Psychoanalytic Study of the Child*, 13, 375–404.
- . (1959). *A genetic field theory of ego formation*. New York: International Universities Press.
- . (1964). Vers une réévaluation de l'autoérotisme. *Psychiatrie de l'enfant*, 7, 269–297.
- . (1965). *The first year of life: A psychoanalytic study of normal and deviant object relations*. New York: International Universities Press.
- . (1979). *L'embryologie du moi. Une théorie du champ pour la psychanalyse*. Paris: Complexe.
- Spitz, René A., with Cobliner, W. Godfrey. (1965). *The first year of life: A psychoanalytic study of normal and deviant development of object relations*. New York: International Universities Press.
- Spock, Benjamin. (1963). The striving for autonomy and regressive object relationship. *Psychoanalytic Study of the Child*, 18, 361–36.
- Spoto, Donald. (1993). *Marilyn Monroe: The autobiography*. New York: HarperCollins.
- Squiggle Foundation. (1988). *Winnicott Studies. The Journal of the Squiggle Foundation. A Celebration of the Life and Work of Marion Milner, No. 3*. London: Squiggle Foundation, 1988.
- Stärcke, August. (1921). The castration complex. *International Journal of Psychoanalysis*, 2, 2, 179–201.
- Starobinski, Jean. (1966). Le concept de nostalgie. *Diogenes* 54, 92–115.
- Stein, Conrad. (1972). Notes relatives au statut scientifique et au statut social de la psychanalyse. *Études freudiennes*, 5–6. (Original work published 1968)
- . (1977). La castration comme négation de la féminité. In his *La mort d'Edipe* (pp. 155–183). Paris: Denoël.
- . (1994). La traversée du tragique en psychanalyse. *Études Freudiennes*, 35, 33–48.
- Stein, Murray. (1996). *Practicing wholeness*. New York: Continuum
- Stein, Murray (Ed.). (1995). *Jungian analysis*. La Salle, IL: Open Court.
- Steiner, John. (1993). *Psychic retreats. Pathological organizations in psychotic, neurotic and borderline patients*. London/New York: Routledge.
- . (1996). Revenge and resentment in the “Oedipus situation”. *International Journal of Psychoanalysis*, 77, 433–444.
- Steiner, Riccardo. (1985). Some thoughts about tradition and change arising from an examination of the British Psycho-Analytical Society's “Controversial Discussions”, 1943–1944, *International Review of Psychoanalysis*, 12, 27–71.
- . (1987). A world-wide international trademark of genuineness? *International Review of Psychoanalysis*, 14, 33–102.
- . (1989). It is a new kind of Diaspora. *International Review of Psychoanalysis*, 16, 35–72.
- . (1989). On narcissism: The Kleinian approach. In Otto F. Kernberg (Ed.), *Narcissistic personality disorder* (pp. 741–770). Philadelphia: W. B. Saunders.
- . (1991). To explain our point of view to English readers in English words. *International Review of Psychoanalysis*, 18, 351–392.
- . (1993). Introduction. In R. Andrew Paskauskas (Ed.), *The complete correspondence of Sigmund*

- Freud and Ernest Jones (pp. 21–49). Cambridge, MA: Harvard University Press.
- . (1999). Some notes on the Heroic Self and the meaning and importance of its reparation for the creative process and the creative personality. *International Journal of Psychoanalysis*, 80, 685–718.
- . (1999). Some observations on projection, identification, projective identification. (Joseph Sandler, Ed.). *International Journal of Psychoanalysis*, 70, 727–35. (Original work published 1989)
- . (2000). ‘It is a new kind of diaspora’: Explorations in the sociopolitical and cultural context of psychoanalysis. London: Karnac.
- . (2001). Affect in psychoanalytic theory: Andre Green on affect and representation. *International Journal of Psychoanalysis*, 82, 877–900.
- Steiner, W. (1994). The Tower of Babel or after Babel in contemporary psychoanalysis? *International Journal of Psychoanalysis*, 75, (5/6), 883–901
- Stekel, Wilhelm. (1895). Über coitus im Kindesalter: eine hygienische studie. *Wiener medizinische Blätter*, 16, 247–249.
- . (1907). *Die Ursachen der Nervosität. Neue Ansichten über deren Entstehung und Verhütung*. Vienna: Knepler.
- . (1908). *Nervöse Angstzustände und ihre Behandlung*. Berlin-Wien: Urban and Schwarzenberg.
- . (1911). *Die Sprache des Traumes*. Wiesbaden, Germany: J. F. Bergmann.
- . (1912). *Die Träume der Dichter*. Wiesbaden, Germany: Bergmann.
- . (1923). *Conditions of nervous anxiety and their treatment* (Rosalie Gabler, Trans.). London: K. Paul, Trench, Trubner and Co.
- . (1924). In memoriam Herbert Silberer. *Fortschritte der Sexualwissenschaft und Psychoanalyse*, 1, 408–420.
- . (1926). Zur Geschichte der analytischen Bewegung. *Fortschritte der Sexualwissenschaft und Psychoanalyse*, 2, 539–575.
- . (1931). *A primer for mothers* (Frida Ilmer, Trans.). New York: Macaulay Co.
- . (1939). *Technique of analytical psychotherapy* (Eden and Cedar Paul, Trans.). London: John Lane.
- . (1943). *The interpretation of dreams: new developments and technique* (Eden and Cedar Paul, Trans.). New York: Liveright Publishing Corp.
- . (1950). *The autobiography of Wilhelm Stekel. The life story of a pioneer psychoanalyst*. New York: Liveright.
- Stengel, Erwin. (1939). On learning a new language. *International Journal of Psychoanalysis*, 20, 471–479.
- Stepansky, Paul. E. (1988). *The memoirs of Margaret S. Mahler*. New York: The Free Press.
- Stephanatos, Gerosimos. (1992). Un pari sous l’Acropole. *Bulletin d’information du Quatrième Groupe*, 12, 56–63.
- Sterba, Editha, and Grinstein, Alexander. (1957). *Understanding your family*. New York: Random House.
- Sterba, Editha. (1929). Nacktheit und Scham. (Nudity and shame). *Zeitschrift für psychoanalytische Pädagogik*, 3.
- . (1941). The school and child guidance. *Psychoanalytic Quarterly*, 10, 445–467.
- . (1945). Interpretation and education. *Psychoanalytic Study of the Child*, 1, 309–318.
- Sterba, Editha., and Sterba, Richard F. (1954). *Beethoven and his nephew; a psychoanalytic study of their relationship*. New York: Pantheon.
- Sterba, Richard F. (1936). *Handwörterbuch der Psychoanalyse*. Vienna: Internationaler psychoanalytischer Verlag.
- . (1940). Dynamics of dissolution of the transference resistance. *Psychoanalytic Quarterly*, 9, 363–380.
- . (1942). *Introduction to the psychoanalytic theory of the libido*. New York: Nervous and Mental Disease Monographs. (Original work published 1931)
- . (1951). A case of brief psychotherapy by Sigmund Freud. *International Journal of Psychoanalysis*, 38, 75–80.
- . (1982). *Reminiscences of a Viennese psychoanalyst*. Detroit: Wayne State University Press.
- . (1987). *Richard Sterba: the collected papers*. New York: North River Press.
- Stern, Daniel N. (1985). *The interpersonal world of the infant. A view from psychoanalysis and developmental psychology*. New York: Basic Books.
- . (1995). *The motherhood constellation: A unified view of parent-infant psychotherapy*. New York: Basic Books.
- Stern, Max. (1951). Anxiety, trauma, and shock. *Psychoanalytic Quarterly*, 20, 179–203.
- Stevens, Anthony. (1982). *Archetypes: A natural history of the self*. London: Routledge
- Stevenson-Hinde, J., and Simpson, M. J. A. (1981). Mothers’ characteristics, interactions, and infants’ characteristics. *Child Development*, 52, 1246–1254.

- Stewart, Walter A. (1964). Depersonalization. *Journal of the American Psychoanalytic Association*, 12, 171–186.
- Stierlin, Helm. (1977). *Psychoanalysis and family therapy*. New York: Jason Aronson.
- Stoller, Robert J. (1968). *Sex and gender: on the development of masculinity and femininity*. New York: Science House.
- . (1973). *Splitting: a case of female masculinity*. New York: Quadrangle Books.
- . (1975). *Perversion: the erotic form of hatred*. New York: Pantheon.
- . (1979). *Sexual excitement: dynamics of erotic life*. New York: Pantheon.
- . (1985). *Observing the erotic imagination*. New Haven: Yale University Press.
- . (1985). *Presentations of gender*. New Haven, London: Yale University Press.
- Stolorow, Robert D. (1977). Notes on the signal function of hypochondriacal anxiety. *International Journal of Psychoanalysis*, 58, 245–246.
- Stolorow, Robert D., and Atwood, George E. (1989). The unconscious and unconscious fantasy: An intersubjective-developmental perspective. *Psychoanalytical Inquiry*, 9, 364–374.
- Stolorow, Robert D., and Atwood, George E. (1992). *Contexts of being. The intersubjective foundations of psychological life*. Hillsdale, NJ and London: The Analytic Press.
- Stolorow, Robert D., Brandschaft, Bernard, and Atwood, George E. (1987). *Psychoanalytic treatment: an intersubjective approach*. Hillsdale, NJ: The Analytic Press.
- Stone, Leo. (1938). Concerning the psychogenesis of somatic illness: physiological and neurological correlates with the psychological theory. *International Journal of Psychoanalysis*, 19, 63–76.
- . (1947). Transference sleep in a neurosis with duodenal ulcer. *International Journal of Psychoanalysis*, 28, 86–118.
- . (1954). The widening scope of indications for psychoanalysis. *Journal of the American Psychoanalytic Association*, 2, 567–594.
- . (1961). *The psychoanalytic situation: an examination of its development and essential nature*. New York: International Universities Press.
- . (1980). *The therapeutic experience and its setting: a clinical dialogue with Robert Langs*. New York: Jason Aronson.
- . (1984). *Transference and its context: selected papers on psychoanalysis*. New York: Jason Aronson.
- Strachey, Alix. (1943). *New German-English psychoanalytical vocabulary*.
- Strachey, James. (1934). The nature of the therapeutic action of psycho-analysis. *International Journal of Psychoanalysis* 15, 127–159. Reprinted in *International Journal of Psychoanalysis* 50 (1969), 275–291.
- . (1943–1974). Introductory notes. In *The standard edition of the complete psychological works of Sigmund Freud*. London: Hogarth.
- . (1963). Obituary of Joan Riviere, 1883–1962. *International Journal of Psychoanalysis*, 44, 228–230.
- . (1966). General preface. In *Standard edition of the complete psychological works of Sigmund Freud* (Vol. 1, pp. 13–26). London: Hogarth.
- . (1969). The nature of the therapeutic action of psycho-analysis. *International Journal of Psychoanalysis*, 50 (2), 275–291.
- Strenger, Carlo. (1991). *Between hermeneutics and science. An essay on the epistemology of psychoanalysis*. Madison, CT: International Universities Press.
- Strozier, Charles B. (1982). *Lincoln's quest for union. Public and private meanings*. New York: Basic Books.
- . (2001). *Heinz Kohut: The making of a psychoanalyst*. New York: Farrar, Straus and Giroux.
- Sugarman, Alan, and Kanner, K. (2000). The contribution of psychoanalytic theory to psychological testing. *Psychoanalytical Psychology*, 17, 3–23.
- Sullivan, Harry Stack. (1940). *Conceptions of modern psychiatry*. Washington, DC: W.A. White Psychiatric Foundation.
- . (1953). *Interpersonal theory of psychiatry*. New York: W.W. Norton.
- . (1954). *The psychiatric interview*. New York: W.W. Norton.
- . (1962). *Schizophrenia as a human process*. New York: W.W. Norton.
- Sulloway, Frank J. (1979). *Freud, biologist of the mind*. New York: Basic.
- Sutherland, John. (1989). *Fairbairn's journey into the interior*. London: Free Association Press.
- Sutton, Nina. (1995). *Bruno Bettelheim: The other side of madness*. (David Sharp, Trans.). London: Duckworth.
- Swales, Peter J. (1982). Freud, Minna Bernays, and the conquest of Rome. New light on the origins of psychoanalysis. *New American Review*, 1–23.
- . (1986). Freud, his teacher, and the birth of psychoanalysis. In Paul E. Stepansky (Ed.), *Freud:*

- Appraisals and reappraisals* (pp. 3–82). New Jersey: The Analytic Press, 1986.
- . (1988). Freud, Katharina and the first “wild analysis.” In P. E. Stepansky (Ed.), *Freud: Appraisals and Reappraisals*, Hillsdale, NJ-London: The Analytic Press, p. 80–164.
- Swerdloff, Bluma. (1981). A tribute to Abram Kardiner, 1891–1981. *Bulletin of the American Psychoanalytic Association*, 21, 42–44.
- Swoboda, Hermann. (1904). *Die perioden des menschlichen organismus in ihrer psychologischen und biologischen Bedeutung*. Leipzig: Deuticke.
- . (1906). *Die gemeinnützige Forschung und der eigennützige Forscher: Antworten auf die von Wilhelm Fließ erhobenen Beschuldigungen*. Vienna: Braümiller.
- . (1911). *Otto Weininger Tod*. Vienna: F. Deuticke.
- . (1917). *Das Siebenjahr*. Leipzig: Orion.
- Symington, Joan, and Symington, Neville. (1996). *The clinical thinking of Wilfred Bion*. London, Routledge.
- Syz, Hans. (1963). Reflections on group or phylo-analysis. *Acta Psychotherapeutica et Psychosomatica*, 2, 37–55.
- Szondi, Leopold. (1952). *Experimental diagnostics of drives*. New York: Grune and Stratton.
- . (1965). *Schicksalanalyse*. Basel and Stuttgart: Benno Schwabe, five volumes, 1965; Bern: Hans Huber, 1952, 1956, 1960, 1963.
- . (1969). *Kain. Gestalten des Bösen*. Bern: Hans Huber.
- . (1973). *Moses: Antwort auf Kain*. Bern: Hans Huber.
- Szwec, Gérard. (1989). Figure de l'étranger, langage et régression formelle. *Revue française de psychanalyse*, 53, 6: 1977–1987.
- . (1993). *La psychosomatique de l'enfant asthmatique*. Paris: Presses Universitaires de France.
- . (1993). Les procédés autocalmants par la recherche répétitive de l'excitation. Les galériens volontaires. *Revue française de psychosomatique*, 4 27–51.
- Tähkä, Veikko. (1970). *Psykoterapian perusteet: psykoanalyttisen teorian pohjalta*. Porvoo, Finland: Söderström.
- Törngren, Pehr Henrik. (1936). *Striden om Freud*. Stockholm: Albert Bonniers Förlag.
- Taft, Jessie. (1958). *Otto Rank*. New York: Julian.
- Taguieff, Pierre-André. (1998). *La couleur et le sang*. Paris: Mille et Une Nuits.
- Taketomo, Y. (1986). Toward the discovery of self: a transcultural perspective, *Journal of the American Academy of Psychoanalysis*, 14, 69–84.
- Tantum, Digby. (1991). The anti-psychiatry movement. In Berrios and Freeman, (Eds.), *150 years of british psychiatry*. London: Gaskell.
- Tartakoff, Helen. (1970). Obituary Elisabeth Geleerd Loewenstein. *International Journal of Psychoanalysis*, 51, p. 71–3.
- Tausk, Marius. (1973). Viktor Tausk as seen by his son. *American Imago* 30 (4), 323–35.
- Tausk, Viktor. (1933 [1919]). Über die Entstehung des Beeinflussungsapparates in der Schizophrenie. *Internationale Zeitschrift für Psychoanalyse* 5, 1–33. On the Origin of the “Influencing Machine” in Schizophrenia. Translated by Dorian Feigenbaum, *PQ* 2 (1933). Reprinted in Robert Fliess, ed., *The Psycho-Analytic Reader*. New York: International Universities Press.
- . (1991), *Sexuality, war, and schizophrenia: Collected psychoanalytic papers*. New Brunswick, NJ: Transaction.
- Teissier, Bernard. (1988). Stratifications, finitude et intuition. In Jean Petitot-Cocorda (Ed.), *Logos et théorie des catastrophes: à partir de l'œuvre de René Thom; Actes du colloque international de 1982* (pp. 59–65). Geneva: Patino.
- Tellenbach, Hubertus. (1976). Phénoménologie de l'intrication entre épilepsie et changement de la personnalité à l'exemple du prince Myichkine de Dostoïewski. *Psychanalyse à l'Université*, 1, 2, 341–354.
- Terr, Lenore. (1990). *Too scared to cry: psychic trauma in childhood*. New York: Harper and Row.
- Tesone, J.E. (1996). Multi-lingualism, word, thing presentations and psychic reality. *International Journal of Psychoanalysis*, 77, 871–883.
- Tesone, Juan-Eduardo. (1996). Multi-lingualism, word-presentations, thing-presentations and psychic reality. *International Journal of Psychoanalysis*, 77, 871–881.
- Thom, René. (1989). *Structural stability and morphogenesis: an outline of a general theory of models*. (D. H. Fowler, Trans.). Reading, MA: Addison-Wesley Pub. (Original work published 1972)
- . (1990). *Semiophysics: a sketch*. (Vendla Meyer, Trans.). Redwood City, CA: Addison-Wesley Pub. Co., Advanced Book Program. (Original work published 1988)
- Thoma, Helmut. (1967). *Anorexia nervosa*, New York: International Universities Press.
- Thompson, Clara. (1950). *Psychoanalysis: evolution and development*. New York: Hermitage House.

- Thompson, Nellie L. (1995). Les schismes dans le mouvement psychanalytique aux États-Unis. *Topique*, 57, 257–270.
- . (1997). Elisabeth Geleerd. In *Jewish women in America: an historical encyclopedia*, Volume One. (pp. 501–502). (Paula E. Hyman and Deborah Dash Moore, Eds.). New York: Routledge.
- . (2001). American women psychoanalysts 1911–1941. *Annual of Psychoanalysis*, 29, 161–177.
- Thuillier, Pierre. (1981). *Darwin and co.* Brussels: Complexe.
- Timms, Edward. (1986). *Karl Kraus, Apocalyptic satirist: Culture and catastrophe in Habsburg Vienna*. New Haven and London: Yale University Press.
- Timms, Edward. (Ed.). (1995). *Freud and the child woman: The memoirs of Fritz Wittels*. New Haven: Yale University Press.
- Tisseron, Serge. (1993). *La honte, psychanalyse d'un lien social*. Paris: Dunod.
- Tisseron, Serge, et al. (1995). *Le psychisme à l'épreuve des générations: clinique du fantôme*. Paris: Dunod.
- Tissot, Samuel Auguste David. (1778). *L'onanisme: Dissertation sur les maladies produites par la masturbation* (5th ed.). Lausanne.
- Tomasi di Palma, A. (1960). "La spersonalizzazione," *Rivista di psicoanalisi*, 6, 1, 5–10.
- Torok, Maria. (1968). Maladie du deuil et fantasme du cadavre exquis. *Revue française de psychanalyse*, 32, 4. (Reprinted in translation as "The illness of mourning and the fantasy of the exquisite corpse," in Abraham and Torok, *The shell and the kernel: Renewals of psychoanalysis*.)
- . (1994). The illness of mourning and the fantasy of the exquisite corpse. In Nicolas Abraham and Maria Torok, *The shell and the kernel: renewals of psychoanalysis* (Nicholas T. Rand, Ed. and Trans.). Chicago: University of Chicago Press. (Original work published 1968)
- Tosquelles, François. (1967). *Structure et rééducation thérapeutique*. Paris: Éditions universitaires.
- . (1984). *Éducation et psychothérapie institutionnelle*. Mantes, France: Hiatus.
- . (1986). *Le vécu de la fin du monde dans la folie*. Nantes, France: Arefpi.
- . (1992). *L'enseignement de la folie*. Toulouse, France: Privat.
- Trapet, Marie Aleth. (1998). Les adages, souvenirs d'enfance du droit, esquisse d'une métapsychologie des adages. Dissertation, University of Paris-VII.
- Trapet, Marie-Dominique. (1998). Le droit dans l'œuvre de Freud. Dissertation, University of Paris-VII.
- Tremblais-Dupré, Thérèse. (1982). Pierre Mâle, prince de la psychiatrie. *Scarabée Internationale*, 3–4, 204–211.
- Tresan, David. (1992). The anima of the analyst. Its development, gender, and soul. In *Psychotherapy* (pp. 73–110). Wilmette, IL: Chiron Publications.
- Trewartha, M. (1990). On postanalytic amnesia. *Annual of Psychoanalysis*, 18, 153–174.
- Triandafillidis, Alexandra. (1991). *La dépression et son inquiétante familiarité*. Paris: Éditions Universitaires.
- Trilling, Jacques. (1973). James Joyce ou l'écriture matricide. *Études Freudiennes*, 7–8, 7–70.
- Trist, Eric; et al. (1982). The Tavistock Institute: origin and early years. *Personal communication* (p. 1–30). New York, Pearl King, Academy of Management, .
- Troisier, Hélène. (1998). *Piera Aulagnier*. Paris: Presses Universitaires de France.
- Troisier, Hélène, and Favreau, Jean. (1990). Plaisir et jouissance: chemins et détours (interview with Jean Favreau). *Revue française de psychanalyse*, 54 (1), 189–196.
- Trombetta, Carlo. (1989). *Édouard Claparède psicologo*. Rome: Armando.
- Trosman, Harry. (1969). The cryptomnesic fragment in the discovery of free association. *Journal of the American Psychoanalytic Association*, 17 (2), 489–510.
- Tucker, P. Trautman, R. (2000). Understanding and treating PTSD: past, present and future. *Bulletin of the Menninger Clinic*, 64, 37–51.
- Tucker, Robert C. (1973). *Stalin as revolutionary, 1879–1929. A study in history and personality*. New York: W.W. Norton.
- Turquet, Pierre. (1975). Threats to identity in the large group. In L. Kreeger (Ed.). *The large group* (p. 87–114). London: Constable.
- Tustin, Frances. (1973). *Autism and childhood psychosis*. New York: Jason Aronson.
- . (1981). *Autistic states in children*. London: Routledge.
- . (1986). *Autistic barriers in neurotic patients*. London: Karnac Books.
- . (1990). *The protective shell in children and adults*. London: Karnac Books.
- Tuttman, Saul. (1981). The significance of Edith Jacobson's *The Self and the Object World* in contemporary object relations theory. In C. Kaye M. Zimmerman, S. Tuttman (Eds.): *Object and Self: A Developmental*

- Approach, Essays in Honor of Edith Jacobson* (p. 81–102). New York : International Universities Press.
- Tyson, Phyllis. (1996). Female psychology: an introduction. *Journal of the American Psychoanalytic Association*, 44(S), 11–22.
- . (2002). The challenges of psychoanalytic developmental theory. *Journal of the American Psychoanalytic Association*, 50, 19–52.
- Tyson, Phyllis, and Tyson, Robert. (1990). *Psychoanalytic theories of development: an integration*. New Haven/London: Yale University Press.
- Tyson, Robert L. (1994). Neurotic negativism and negation in the psychoanalytic situation. *Psychoanalytic Study of the Child*, 49, 293–314.
- Tzavaras, Athanase. (1981). Andréas Embirikos et la psychanalyse. *Bulletin de la Société d'études de la culture néohellénique et de l'éducation*, 5. [Au : Page numbers ?]
- . (1984). *La psychanalyse et la Grèce*. Athens: Société d'études de la culture néohellénique et de l'éducation.
- . (1993). Psychanalyse “et” Grèce—dix ans après. *IO—Revue Internationale de Psychanalyse*, 4, 157–162.
- . (1996). Georges A. Zavitzianos: Corfu, 1909–Maryland/E.U, 1995. *Cahiers de psychiatrie*, 53, 10–13.
- Tzavaras, Hélène. (1993). Oedipe ou Ulysse ? Identité et filiation de la psychanalyse en Grèce. *IO—Revue Internationale de Psychanalyse*, 4, 87–93.
- Tzavaras, Hélène, and Tzavaras, Athanase. (1995). Au pays d'Oedipe. *Panoramiques*, 22, 156–158.
- Ullmann, Stephen. (1952). *Précis de sémantique française*. Bern: Francke.
- Urbantschitsch, Rudolf von. (1924). *Psychoanalyse: ihre bedeutung und ihr einfluss auf jugenderziehung, kinderaufklärung, berufs- und liebeswahl*. Vienna-Leipzig: M. Perles.
- Urbantschitsch, Rudolf von. (1928). *Psychoanalysis for all*. London: C. S. Daniel.
- . (1958). *Myself not least; a confessional autobiography of a psychoanalyst and some explanatory history cases*. London: Jarrolds.
- Urribarri, Rodolfo. (1999). Descorriendo el velo. Sobre el trabajo de la latencia. *Revista de Psicoanálisis de la Asociación Psicoanalítica Argentina*, 66, 1.
- Urtubey, Luisa de. (1983). *Freud et le Diable*. Paris: Presses Universitaires de France.
- . (1988). Dites tout ce qui vous passe par la tête, tout comme cela vous vient et dans la langue où cela vous vient. *Revue française de psychanalyse*, 52 (2), 463–472.
- . (1994). Le travail de contre-transfert. *Bulletin de la Société de psychanalyse de Paris*, 31, p. 147–148.
- Vaidyanathan, T.G. (1996). *Hinduism and psychoanalysis: A reader*. Delhi, Oxford University Press.
- Valabrega, Jean-Paul. (1967). Le problème anthropologique du phantasme. In Aulagnier, Piera, et al. *Le désir et la perversion* (pp. 163–206). Paris: Seuil.
- . (1974). Problèmes de théorie psychosomatique. In *Encyclopédie médico-chirurgicale: Psychiatrie*. Paris: E.M.-C. (Original work published 1966)
- . (1980). *Phantasme, mythe, corps et sens: une théorie psychanalytique de la connaissance*. Paris: Payot.
- . (1992). *Le motif du jumeau: identité-altérité*, *Topique* 50, 181–183.
- . (1994). *La formation du psychanalyste*. Paris: Payot.
- . (1999). Trente an après...Entretien avec Sophie de Mijolla-Mellor. *Topique*, 69.
- . (2001). *Mythes, conteurs de l'inconscient: questions d'origine et de fin*. Paris: Payot et Rivages.
- Valdizán, Hermilio. (1918). La psicoterapia extrapsiquiátrica. *Anales*, Facultad de medicina de Lima, 250–271.
- . (1920). Ensayo de psicología del enfermo. *Revista de psiquiatría y disciplinas conexas*, 3, 1–2, 19–38.
- . (1923). *Diccionario de medicina peruana*. t. I, Lima, Talleres gráficos del asilo “Víctor Larco Herrera,” p. 346.
- . (1923). Factores psicológicos de la demencia precoz. *Revista de psiquiatría y disciplinas conexas*, 4, 4, 263–286.
- . (1926). La rebelión de la libido sexual en la vejez. *Mercurio Peruano*, 9, 338–355.
- Valenstein, Arthur F. (1981). Insight as an embedded concept in early historical phase of psychoanalysis. *Psychoanalytic Study of the Child*, 36, 307–318.
- Valentin, Éric. Les phobies chez l'enfant. *Perspectives Psychiatriques*, 4, 265–319.
- Van den Daele, L. (1994). Revision of the topographic and structural theories. *Psychoanalysis and Contemporary Thought*, 17, 407–446.
- Van Der Kolk, Bessel, et al. (1996). *Traumatic stress: the effects of overwhelming experience on mind, body, and society*. New York: Guilford Press.
- Van Emden, Jan. (1912). *Over psycho-analyse*. Leiden, Netherlands: Van Doesburgh. (Translation of Sigmund Freud, *Five Lectures on Psycho-analysis*.)



- . (1912). Selbstbestrafung wegen abortus. *Zentralblatt für Psychoanalyse*, 3, 647.
- . (1917). *Beschouwingen over oorlog en dood*. Leiden, Netherlands: Van Doesburgh. (Translation of Sigmund Freud, *Thoughts for the Times on War and Death*.)
- . (1925). Zur Bedeutung der Spinne in Symbolik und Folklore. *Internationale Zeitschrift für Psychoanalyse*, 11, 512–513.
- Van Gennep, Arnold. (1960). *The rites of passage*. (M. B. Vizedom and G. B. Caffee, Trans.). Chicago: University of Chicago Press. (Original work published 1909)
- Vanggaard, Thorkil. (1972). *Phallos*. New York: International Universities Press.
- Vasse, Denis. (1974). *L'ombilic et la voix*. Paris: Le Seuil.
- Vaughan, Sarah, et al. (2000). Can we do psychoanalytic outcome research? A feasibility study. *International Journal of Psychoanalysis*, 81, 513–528.
- Vaysse, Jean-Marie. (1999). *L'inconscient des modernes: Essai sur l'origine métaphysique de la psychanalyse*. Paris: Gallimard.
- Veldman, Franz. (1998). *Haptonomie, science de l'affectivité* (7th ed.). Paris: Presses Universitaires de France.
- Venisse, Jean-Luc (Ed.). (1991). *Les nouvelles addictions*. Paris: Masson.
- Vermès, Geneviève. (1992). Un rédacteur pour le "Journal de psychologie normale et pathologique" : Ignace Meyerson, XIe Meeting annuel de Cheiron, Madrid, septembre 1991. *Rev. hist. psychol.*, 2, 353–359.
- Vermorel, Henri. (1994). Raymond de Saussure ou la passion de la psychanalyse. (p. 74). In C. Degoumois (Ed.), *Actes du centenaire de la naissance de Raymond de Saussure*. Genève : Médecine et Hygiène.
- . (1995). La pulsion, de Goethe et de Schiller à Freud. In H. Vermorel et al. (Eds.), *Freud, Judéité, Lumières et Romantisme* (pp. 133–149.). Lausanne: Delachaux & Niestlé.
- Vermorel, Henri, and Madeleine Vermorel. (1986). Freud et la culture allemande. *Revue française de psychanalyse*, 49, 1034–62.
- . (1993). *Sigmund Freud et Romain Rolland. Correspondance 1923–1936*. (Alain de Mijolla, Ed.). Paris: Presses Universitaires de France.
- Vermorel, Madeleine. (1990). The drive (*Trieb*), from Goethe to Freud. *International Review of Psychoanalysis*, 17, 249–56.
- . (1995). La pulsion, de Goethe et de Schiller à Freud. In *Freud, judéité, lumières et romantisme*. (p. 133–49). (H. Vermorel, et al, Eds.). Lausanne: Delachaux and Niestlé.
- Vezzetti, Hugo (1996). *Aventuras de Freud en el país de los argentinos*. Buenos Aires: Paidós.
- . (1911). Freud en langue espagnole. *Revue internationale d'histoire de la psychanalyse*, 4, 189–207.
- Vichyn, Bertrand. (1984). Naissance des concepts: autoérotisme et narcissisme. *Psychanalyse à l'Université*, 936.
- Vidal, Fernando. (1994). *Piaget before Piaget*. Cambridge, MA: Harvard University Press.
- Viderman, Serge. (1970). *La construction de l'espace analytique*. Paris: Denoël.
- . (1977). *Le céleste et le sublunaire*. Paris: Presses Universitaires de France.
- . (1987). *Le disséminaire*. Paris: Presses Universitaires de France.
- . (1992). *De l'argent en psychanalyse et au-delà*. Paris: Presses Universitaires de France.
- Vigneault, Jacques. (1993). Transferts et déplacements: fondements de la psychanalyse en Amérique du Nord. *Trans*, 3, 223–237.
- Vikár, György. (1985). Obituary Imre Hermann, 1889–1984. *International Journal of Psychoanalysis*, 66, 111.
- . (1994). Der Beitrag der Budapester psychoanalytischen Schule zur Objektbeziehungstheorie. *International Forum for Psychoanalysis*, 10, 52–60.
- Villele, L. (1997). From the sway of the pleasure principle: Ghost of a tiger. *Psychoanalytic Review*, 84, 281–294.
- Vindreau, Christine. (1991). La boulimie dans la clinique psychiatrique. In: Bernard Brusset and Catherine Couvreur (Eds.). *La boulimie* (pp. 63–79). Paris: Presses Universitaires de France.
- Volkan, Vamik D. (1986). The narcissism of minor differences between opposing nations. *Psychoanalytical Inquiry*, 6, 175–192.
- . (1995). *The infantile psychotic self and its fates. Understanding and treating schizophrenics and other difficult patient*. Northvale, NJ: Aronson Inc.
- Von Brentano, Franz. (1874). *Psychology from an empirical standpoint*. Edited by Oskar Kraus, English edition edited by Linda L. McAlister, translated by Antos C. Rancurello, D. B. Terrell, and Linda L. McAlister, with a new introduction by Peter Simons. London, New York: Routledge, 1995.
- Waelder, Robert. (1929). Psychological aspects of war and peace. *Geneva Studies*, 10, 2.

- . (1936). The principle of multiple function: observations on over-determination. *Psychoanalytic Quarterly*, 5, 45–62.
- . (1960). *Basic theory of psychoanalysis*. New York: International Universities Press.
- . (1967). *Progress and revolution; a study of the issues of our age*. New York: International Universities Press.
- . (1976). *Psychoanalysis: Observations, theory, application: Selected papers of Robert Waelder*. New York: International Universities Press.
- Wagonfeld, S., rep. (1982). Panel: gender and gender role. *Journal of the American Psychoanalytic Association*, 30, 185–196.
- Waldvogel, A. (1990). Karl Kraus und die Psychoanalyse. Eine historisch-dokumentarische Untersuchung. *Psyche—Zeitschrift für Psychoanalyse und ihre Anwendungen* 1990, 44 (5), 412–444.
- Walker, Janet. (1993). *Couching resistance: Women, film, and psychoanalytic psychiatry*, Minneapolis: University of Minnesota Press.
- Wallace, E. (1983). *Freud and Anthropology: A History and Reappraisal. Psychological Issues. Monograph 55*. New York: International Universities Press.
- Wallerstein, Robert S. (1978). The mental health professions: Conceptualization and reconceptualization of a new discipline. *International Review of Psychoanalysis*, 5, 377–392.
- . (1986). Psychoanalysis as a science: response to new challenges. *Psychoanalytic Quarterly*, 55, 414–451.
- . (1989). Psychoanalysis and psychotherapy: an historical perspective. *International Journal of Psychoanalysis*, 70, 563–592.
- . (1995). *The talking cures*. New Haven and London: Yale University Press.
- . (1998). *Lay analysis: Life inside the controversy*. Hillsdale, NJ: Analytic Press.
- . (2001). The generations of psychotherapy research: an overview. *Psychoanalytic Psychology*, 18, 243–267.
- . (2002). The growth and transformation of American ego psychology. *Journal of the American Psychoanalytic Association*, 50, 135–170.
- Wallerstein, Robert S. (Ed.). (1991). *The doctorate in mental health: An experiment in mental health professional education*. Lanham, MD: University Press of America.
- Wallon, Henri (1931). Comment se développe chez l'enfant la notion du corps propre. *Journal de Psychologie*. (Nov.–Dec.): 705–748.
- . (1970). *De l'acte à la pensée*. Paris: Flammarion. (Original work published 1942)
- Walser, Hans H. (1976). Psychoanalyse in der Schweiz. In D. Eicke (Ed.): *Die psychologie des 20. Jahrhunderts* (Vol. 2, pp. 1192–1218). Zürich: Kindler.
- Walter, Bruno. (1946). *Theme and variations. An autobiography*. New York: Alfred A. Knopf.
- Wangh, Martin, (Ed.). (1962). *Fruition of an idea*. New York, International Universities Press.
- Watzlawick, Paul, Beavin, Janet Helmick, and Jackson, Don D. (1967). *Pragmatics of Human Communication*. New York: W. W. Norton.
- Weber, Kaspar. (1994). Gespräche mit Margrit Wettstein, die noch die Anfangszeiten unserer Gesellschaft erlebt hat. *Bulletin de la Société suisse de psychanalyse*, 37, 45–54.
- Wehr, Gerhard. (1987). *Jung*. Boston and London: Shambhala.
- Weinberger, J. et al. (2000). On integrating psychoanalysis and cognitive science. *Psychoanalysis and Contemporary Thought*, 23, 147–176.
- Weininger, Otto. (1906). *Sex and character*. New York: G. P. Putnam's Sons. (Original work published 1903)
- . (2001). *A translation of Weininger's "Über die letzten Dinge, 1904–1907," On last things*. Lewiston, NY: Edwin Mellen Press. (Original work published 1904)
- Weiss, Edoardo. (1931). *Elementi di psicoanalisi*. Milan: Ulrico Hoepli.
- . (1951). Paul Federn's scientific contributions: in commemoration. *International Journal of Psychoanalysis*, 32 (4), 1–8.
- . (1952). *Introduction to Paul Federn's ego psychology and the psychoses*. New York: Basic Books.
- . (1960). *The structure and dynamics of the human mind*. New York: Grune and Stratton.
- . (1964). *Agoraphobia in the light of ego psychology*. New York, Grune & Stratton.
- . (1966). Paul Federn: The theory of the psychoses. In F. Alexander, S. Eisenstein and M. Grotjan (Eds.), *Psychoanalytic pioneers*. (pp. 142–159). New York: Basic Books.
- Weiss, Joseph. (1990, March). Unconscious mental functioning. *Scientific American*, 103–109.
- . (1993). *How psychotherapy works: Process and technique*. New York: Guilford.

- Weiss, Joseph, Sampson, Harold, and The Mount Zion Psychotherapy Research Group. (1986). *The psychoanalytic process: theory, clinical observation, and empirical research*. New York: Guilford.
- Weissenberg, Siegfried. Über Enkopresis. *Zeitung der Kinderpsychiatrie*, 1 (1926): 69.
- Weissman, Stephen M. (1977). Face to face: The role of vision and the smiling response. *Psychoanalytic Study of the Child*, 32, 421–450.
- Wellton, Estela V. (1988). *Mother, Madonna, whore: The idealization and denigration of motherhood*. London: Free Association Books.
- Welsch, Ursula, and Wiesner, Michaela. (1988). *Lou Andreas-Salomé. Vom Lebensurgrund zur Psychoanalyse*. München-Wien-Leipzig: Internationaler psychoanalytischer Verlag.
- Wender, Leonardo, et al. (1992). Argentina. In Peter Kutter (Ed.), *Psychoanalysis International, A Guide to Psychoanalysis throughout the World* (vol. 2). Stuttgart-Bad Cannstatt: Frommann-Holzboog.
- Werman, D.S. (1983). Suppression as a defense. *Journal of the American Psychoanalytic Association*, 31(S), 405–415.
- Westkott, Marcia. (1986). *The feminist legacy of Karen Horney*. New Haven, CT: Yale University Press.
- Wetzler, S. and Sweeney, J. (1986). Childhood amnesia: a cognitive-psychological conceptualization. *Journal of the American Psychoanalytic Association*, 34, 663–686.
- Whithe, Lancelot. (1961). *L'Inconscient avant Freud*. Paris: Payot.
- Whiting, Carlos. (1980). Notas para la historia del psicoanálisis en Chile. *Revista chilena de psicoanálisis*, 2 (1), 19–26.
- Whiting, J. W. M. (1960). Totem and taboo—a re-evaluation. *Science and Psychoanalysis*, 3, 150–154.
- Whitrow, Magda. (1993). *Julius Wagner-Jauregg (1857–1940)*. London: Smith-Gordon.
- Widlöcher, Daniel (1970). *Les nouvelles cartes de la psychanalyse*. Paris: Odile Jacob.
- . (1970). *Freud et le problème du changement*. Paris: Presses Universitaires de France.
- . (1979). Preface. In Otto Kernberg, *Les troubles limites de la personnalité*. Toulouse, France: Privat.
- . (1986). *Métapsychologie du sens*. Paris: Presses Universitaires de France.
- . (1992). De l'émotion primaire à l'affect différencié. In P. Mazet, S. Lebovici (Eds.), *Émotions et Affects chez le bébé et ses partenaires*. Paris: Eshel, p. 45–55.
- . (1993). Intentionnalité et psychopathologie. *Revue internationale de psychopathologie*, 10, 193–224.
- . (1993). L'analyse cognitive du silence en psychanalyse. Quand les mots viennent à manquer. *Revue internationale de psychopathologie*, 12, 509–528.
- . (1994). Psychanalyse et processus de changement. In his *Traité de psychopathologie*. Paris: Presses Universitaires de France.
- . (1997). *Les nouvelles cartes de la psychanalyse*. Paris: Odile Jacob.
- Wiener psychoanalytische Vereinigung. (1937). *Lehrkurse und Veranstaltungen Wintersemester 1937-1938, Programm*. Wien: Lehrausschuss der Wiener psychoanalytischen Vereinigung.
- Wiener, Norbert. (1950). *The human use of human beings: cybernetics and society*. Boston: Houghton Mifflin.
- Wilbur, George B. (1943). Isador H. Coriat: Obituary. *Psychoanalytic Review*, Vol. 30, pp. 479–83.
- Wilbur, George (Ed.). (1951). *Psychoanalysis and culture*. New York: International Universities Press.
- Will, Herbert. (1985). Freud, Groddeck und die Geschichte des “Es.” *Psyche*, 150–169.
- . (1987). *Georg Groddeck: die Geburt der Psychosomatik*. Munich: Deutscher Taschenbuch Verlag (dtv).
- . (1994). Ferenczi und Groddeck: eine Freundschaft. *Psyche*, 720–737.
- Willick, Martin. (2001). Psychoanalysis and schizophrenia: A cautionary tale. *Journal of the American Psychoanalytic Association*, 49, 27–56.
- Wilson, C. Philip. (1968). Psychosomatic asthma and acting out: A case of bronchial asthma that developed de novo in the terminal phase. *International Journal of Psychoanalysis*, 49 (2–3), 330–333.
- Wilson, Charles, Hogan, C., and Mintz, Ira. (1985). *Fear of being fat: the treatment of anorexia and bulimia (2nd ed)*, North Vale, NJ: Aronson.
- Wilson, N. (2002). Depression and its relation to light deprivation. *Psychoanalytic Review*, 89, 557–568.
- Wilson, Samuel, et al. (Eds.). (1986, December). The “10/40” celebration. *Los Angeles Psychoanalytic Bulletin*, special anniversary issue.
- Winnicott, Donald W. (1941). The observation of infants in a set situation. *International Journal of Psychoanalysis*, 22, 229–249.
- . (1949). Hate in the counter-transference. *International Journal of Psychoanalysis*, 30, 69–74.
- . (1952). Psychosis and child care. In: *Collected papers* (pp. 219–228). New York: Basic Books, 1958.

- . (1953). Transitional objects and transitional phenomena, a study of the first not-me possession. *Collected papers, through paediatrics to psycho-analysis* (pp. 229–242). (Reprinted from *International Journal of Psychoanalysis*, 34 (1951), 89–97.)
- . (1954). Withdrawal and regression. In *Collected Papers*. London: Tavistock, 1958
- . (1955). Aggression in relation to emotional development. In *Collected papers, through paediatrics to psycho-analysis*. London: Tavistock Publications, 1958, pp. 204–218.
- . (1956). Primary maternal preoccupation. In *Collected Papers, Through Paediatrics to Psychoanalysis* (p. 300–305). London: Tavistock Publications, 1958.
- . (1958). *Collected papers. Through paediatrics to psychoanalysis*. New York: Basic Books.
- . (1958). *Through paediatrics to psycho-analysis*. London: Tavistock.
- . (1958). Metapsychological and clinical aspects of regression within the psycho-analytical set-up. In *Collected papers: through paediatrics to psycho-analysis*. London: Tavistock (Original work published 1954)
- . (1958). Mind and its relation to the psychosoma. In *Collected papers, Through paediatrics to psychoanalysis* (p. 243–54). London: Tavistock Publications. (Reprinted from *British Journal of Medical Psychology*, 27, (1954), 201–209.)
- . (1958). Primitive emotional development. In *Collected papers: Through paediatrics to psycho-analysis* (pp. 145–156). London: Tavistock Publications. (Reprinted from *International Journal of Psychoanalysis*, 26 (1945), 137–143.)
- . (1958). Psychosis and child care. In his *Collected papers: Through paediatrics to psycho-analysis* (pp. 219–228). London: Tavistock Publications. (Original work published 1952)
- . (1958). Symptom tolerance in paediatrics. In his *Collected papers: Through paediatrics to psycho-analysis* (pp. 101–117). London: Tavistock Publications. (Original work published in 1953)
- . (1958). The observation of infants in a set situation. In *Collected papers, Through paediatrics to psychoanalysis* (p. 52–69). London: Tavistock Publications. (Reprinted from *International Journal of Psychoanalysis*, 22 (1941), 229–249.)
- . (1960). The theory of the parent-infant relationship. *International Journal of Psychoanalysis*, 41 (6), 585–595.
- . (1963). *Memories, dreams, reflections*. By C.G. Jung. London, Collins & Routledge, 1963. *International Journal of Psychoanalysis*, 45, 450–455.
- . (1964). *The child, the family, and the outside world*. London: Penguin Books.
- . (1964). Further thoughts on babies as persons. In his *The child, the family and the outside world* (p. 85–92). Harmondsworth, Penguin Books. (Original work published 1947)
- . (1965). *The maturational processes and individual development*. London: Hogarth Press and the Institute of Psycho-Analysis.
- . (1965). *The maturational processes and the facilitating environment: studies in the theory of emotional development*. London: Hogarth and the Institute of Psycho-analysis.
- . (1965). Ego distortion in terms of true and false Self. In *The maturational processes and the facilitating environment* (pp. 140–152). London: Hogarth and the Institute for Psycho-Analysis. (Original work published 1962)
- . (1965). Ego-integration in child development. *The maturational processes and the facilitating environment* (pp. 56–63). London: Hogarth and the Institute of Psycho-Analysis. (Original work published 1962)
- . (1965). The capacity to be alone. In *The maturational processes and the facilitating environment* (p. 29–36). London: Hogarth Press and the Institute of Psycho-Analysis. (Reprinted from *International Journal of Psychoanalysis*, 39 (1958), 416–420.)
- . (1966). Psycho-somatic illness in its positive and negative aspects. *International Journal of Psychoanalysis*, 47, 510–516.
- . (1967). Mirror-role of mother and family in child development. In *Playing and reality*. Harmondsworth: Penguin, 1974.
- . (1967). The aetiology of infantile schizophrenia, in terms of adaptive failure. In *Thinking about children*. (p. 218–223). Shepherd, Ray, Johns, Jennifer, and Taylor Robinson, Helen (Eds.). London: Karnac, 1995.
- . (1968). The squiggle game. In *Voices: The Art and Science of Psychotherapy*, 4 (1).
- . (1969). Development of the theme of the mother's unconscious as discovered in psychoanalytic practice. In C. Winnicott, R. Shepherd, M. Davis (eds.): *Psychoanalytic explorations*. London: Karnac Books.
- . (1970). The mother-infant experience of mutuality. In E. Anthony, T. Benedek (Eds.), *Parent-hood: Its psychology and psychopathology*. Boston: Little, Brown.
- . (1971). *Playing and reality*. London: Tavistock Publications.

- . (1971). *Therapeutic consultations in child psychiatry*. London: Hogarth Press and the Institute of Psycho-Analysis.
- . (1971). The use of an object and relating through identifications. In his *Playing and reality*. (p. 101–121). London: Tavistock Publications.
- . (1974). Fear of breakdown. *International Review of Psycho-Analysis*, 1, 103–7.
- . (1975). Aggression in relation to emotional development. In *through paediatrics to psychoanalysis* (pp. 204–218). London: Hogarth. (Original work published 1955)
- . (1975). Through paediatrics to psycho-analysis. London: Hogarth Press and the Institute of Psycho-analysis.
- . (1975). Transitional objects and transitional phenomena. In *Through paediatrics to psycho-analysis*. (p. 229–242). London: Hogarth Press. (Original work published 1953)
- . (1984). *Deprivation and delinquency*. London: The Winnicott Trust.
- . (1984). The antisocial tendency. In his *Deprivation and delinquency*. London: Tavistock. (Original work published 1956)
- . (1987). *Babies and their mothers*. (Clare Winnicott, Ray Shepherd, and Madeleine Davis, Eds.). Reading, MA: Addison-Wesley.
- . (1988). *Winnicott studies. The journal of the Squiggle Foundation. A celebration of the life and work of Marion Milner*. London: The Squiggle Foundation.
- . (1989). *Psycho-analytic explorations*. Cambridge, MA: Harvard University Press.
- . (1989). Development of the theme of the mother's unconscious as discovered in psycho-analytic practice. In his *Psychoanalytic explorations* (pp. 247–250). Cambridge, MA: Harvard University Press.
- Winterstein, Alfred F. (1911). Drei Fälle von Versprechen. *Internationale Zeitschrift für Psychoanalyse*, 2, 292–293.
- . (1920). Die Nausikaepisode in der Odyssee. *Imago*, 6, 349–383.
- . (1928). Die Pubertätstritten der Mädchen und ihre Spuren im Märchen: eine psychoanalytische Studie. *Imago*, 14, 199–274.
- . (1934). Contributions to the problem of humor. *Psychoanalytic Quarterly*, 3, 303–316.
- . (1946). *Adalbert Stifter, Persönlichkeit und Werk: eine psychoanalytische Studie*. Vienna: Phönix.
- . (1949). *Telepathie und Hellsehen im Lichte der modernen Forschung und wissenschaftlichen Kritik*. Vienna: Phönix.
- . (1954). A typical dream-sensation and its meaning. *International Journal of Psychoanalysis*, 35, 229–233.
- . (1956). On the oral basis of a case of male homosexuality. *International Journal of Psychoanalysis*, 37, 298–302.
- Wise, I. (2000). Pleasure in phantasy and reality. *International Journal of Psychoanalysis*, 81, 156–158.
- Wittels, Fritz. (1923). *Sigmund Freud, his personality, his teaching, his school* (E. and C. Paul, Trans.). London: Allen & Unwin.
- . (1932). Revision of a biography. *Psychoanalytic Review*, 19, 241–256.
- . (1941). Paul Schilder, 1886–1940. *Psychoanalytic Quarterly*, 10, 131–134.
- Wittenberger, Gerhard. (1995). *Das "Geheime Komitee" Sigmund Freuds. Institutionalisierungsprozesse in der psychoanalytischen Bewegung zwischen 1912 und 1927*. Tübingen: Diskord.
- . (1996). The circular letters (Rundbriefe), as a means of communication of the "secret committee" of Sigmund Freud. *International Forum of Psychoanalysis*, 5, 111–121.
- Wittkower, Eric. (1953). *Emotional Factors in skin disease*. New York, Paul Hoeber.
- Wittkower, Eric, and Cleghorn, Robert. (Eds.). (1954). *Recent developments in Psychosomatic Medicine*. London, Sir Isaac Pitman.
- Wittkower, Eric, and Dongier, Maurice (Eds.). (1981). *Divergent views in Psychiatry*. Baltimore, MD, Harper & Row.
- Wolfenstein, Martha. (1954). *Children's humor: A psychological analysis*. Glencoe, IL: Free Press.
- . (1955). French parents take their children to the park. In Margaret Mead and Martha Wolfenstein (Eds.), *Childhood in contemporary cultures* (pp. 99–117). Chicago: University of Chicago Press.
- . (1957). *Disaster: A psychological essay*. Glencoe, IL: Free Press.
- . (1966). Goya's dining room. *Psychoanalytic Quarterly*, 35, 47–83.
- . (1966). How is mourning possible? *Psychoanalytic Study of the Child*, 21, 93–123.
- . (1969). Loss, rage, and repetition. *Psychoanalytic Study of the Child*, 24, 432–462.
- . (1973). The image of the lost parent. *Psychoanalytic Study of the Child*, 28, 433–456.

- Wolfenstein, Martha, and Leites, Nathan. (1950). *Movies: A psychological study*. Glencoe, IL: Free Press.
- Wolff, Christian. (1968). *Psychologia empirica*. Hildesheim: Olms. (Original work published 1732)
- . (1968). *Psychologia rationalis*. Hildesheim: Olms. (Original work published 1734)
- Woolf, Moshe. (1941). The child's moral development. In K. R. Eissler (Ed.), *Searchlights on delinquency* (pp. 263–272). London: Imago.
- . (1955). On castration anxiety. *International Journal of Psychoanalysis*, 36, 95–104.
- Worbs, Michael. (1983). *Nervenkunst. Literatur und Psychoanalyse im Wien der Jahrhundertwende*. Frankfurt-am-Main.
- . (1954). *Fragments of an analysis with Freud*. New York: Simon and Schuster.
- Wright, Elizabeth. (1992). *Feminism and psychoanalysis: A critical dictionary*. Oxford: Blackwell.
- Wright, R. J., Rodriguez, M., and Cohen, S. (1998). Review of psychosocial stress and asthma: an integrated biopsychosocial approach. *Thorax*, 53, 1066–1074.
- Wulff, Mosche. (1912). Beitrage zur infantilen Sexualität. *Zentralblatt für Psychoanalyse*, 2, 6–17.
- . (1932). Über einen interessanten oralen Symptomenkomplex und seine Beziehung zur Sucht. *Internationale Zeitschrift für Psychoanalyse*, 18, 283–302.
- . (1946). Fetishism and object choice in early childhood. *Psychoanalytic Quarterly*, 15, 450–471.
- Yalom, Irwin D, Lunde, T, Moos, RH and Hamburg, DA. (1968). "Postpartum Blues" Syndrome. *Arch Gen Psychiat*, 18: 16–27.
- Yerushalmi, Yosef Hayim. (1991). *Freud's Moses: Judaism terminable and interminable*. New Haven, CT: Yale University Press.
- . (1991). *The purloined Kiddush cups: reopening the case on Freud's Jewish heritage*. Binghamton: State University of New York.
- Young-Bruehl, Elizabeth. (1988). *Anna Freud: A biography*. New York: Summit Books.
- Yuan T.A. (2000). China in the history of psychoanalysis: a possible fate for psychoanalysis at the dawn of the millennium. 8th International Meeting of the International Association for the History of Psychoanalysis.
- Zagury, Daniel. (1996). Entre psychose et perversion narcissique, une clinique de l'horreur: les tueurs en série. *L'Évolution psychiatrique*, 59 (1).
- Zaltzman, Nathalie. (1986). Baiser la mort, une sexualité mélancolique. *Topique*, 38.
- Zavitzianos, Georges. (1967). Problems of technique in the analysis of a juvenile delinquent: therapeutic alliance and transference neurosis. *International Journal of Psychoanalysis*, 48, 439–447.
- . (1972). Homeovestism: perverse form of behavior involving wearing clothes of the same sex. *International Journal of Psychoanalysis*, 53 471–477.
- . (1977). The object in fetishism, homeovestism and transvestism. *International Journal of Psychoanalysis*, 58, 487–495.
- . (1981). Andréas Embirikos, psycho-analyst. *Le mot*, 20.
- . (1982). The perversion of fetishism in women. *Psychoanalytic Quarterly*, 51, 405–425.
- Zepf, Siegfried. (2001). Incentives for a reconsideration of the debate on metapsychology. *International Journal of Psychoanalysis*, 82, 463–484.
- Zetzel, Elisabeth. (1956). Current concepts of transference. *International Journal of Psychoanalysis*, 37, 369.
- Zetzel, Elisabeth. (1965). The theory of therapy in relation to a developmental model of the psychic apparatus. *International Journal of Psychoanalysis*, 46, 39.
- . (1968). The so-called good hysteric. *International Journal of Psychoanalysis*, 49, 256–260.
- . (1961). Melanie Klein 1882–1960. *The Psychoanalytic Quarterly*, 30, 420–425.
- . (1969). 96 Gloucester Place: some personal recollections. *International Journal of Psychoanalysis*, 50, 717–719.
- . (1970). *The capacity for emotional growth*. New York: International Universities Press.
- Zhang, Jingyuan (1989). Sigmund Freud and Modern Chinese Literature. *Ph.D. dissertation*. Cornell University.
- Ziferstein, Isidore. (1966). Paul Ferdinand Schilder 1886–1940. Psychoanalysis and psychiatry. In *Psychoanalytic pioneers* (F. Alexander, S. Eisenstein, and M. Grotjahn, Eds.). London: Basic Books.
- Žižek, Slavoj. (1989). *The sublime object of ideology*. London, New York: Verso.
- Zlocisti, T. (1913). Adolf Baginsky. *Ost und West*. 561–564.
- Zottl, Anton. (1982). *Otto Rank: Das Lebenswerk eines Dissidenten der Psychoanalyse*. München: Kindler.
- Zucker, Kenneth J, and Bradley, Susan J. (1995). *Gender identity disorder and psychosexual problems in children and adolescents*. New York: Guilford Press.

Zulliger, Hans. (1928). La psychanalyse et les écoles nouvelles (L. Leuzinger, Trans.). *Revue française de psychanalyse*, 2 (4), 711–720.

———. (1930). *Psychanalyse à l'école* (Jean-Pierre Peyraube, Trans.). Paris: Flammarion.

———. (1934). Prophetic dreams. *International Journal of Psychoanalysis*, 15 (2–3), 191–208.

———. (1950). Psycho-analysis and the form-interpretation test. *International Journal of Psychoanalysis*, 31 (1–2), 152–155.

Zweig, Stefan. (1932). *Mental healers: Franz Anton Mesmer, Mary Baker Eddy, Sigmund Freud*. New York: Viking Press.

# TRANSLATION OF CONCEPTS/NOTIONS

## TRANSLATION OF CONCEPTS/NOTIONS

This glossary is a translation of most of the notions and concepts discussed in the *Dictionary* into five languages: French, German, Italian, Portuguese, and Spanish.

### **abandonment**

*Fr.*: abandon ; *Ger.*: Verlassen(heit) *It.*: abbandono; *Port.*: abandono; *Span.*: abandono.

### **abstinence/rule of abstinence**

*Fr.*: abstinence-règle d'abstinence ; *Ger.*: Abstinenz, Abstinenz Regel *It.*: astinenza-regola di astinenza; *Port.*: abstinência-regra de abstinência; *Span.*: abstinencia-regla de abstinencia.

### **act/action**

*Fr.*: acte, action ; *Ger.*: Akt, Aktion/Handlung *It.*: atto, azione; *Port.*: acto, acção; *Span.*: acto, acción.

### **action-language**

*Fr.*: langage d'action; *Ger.*: Handlungssprache; *It.*: linguaggio d'azione; *Port.*: linguagem de acção; *Span.*: lenguaje de acción.

### **acting out/acting in**

*Fr.*: acting-out/acting-in ; *Ger.*: Ausagieren/Acting-in *It.*: acting out/acting in; *Port.*: atuação-acting out/acting in; *Span.*: actuación/acting in.

### **action-(re)presentation**

*Fr.*: représentation d'action; *Ger.*: Handlungsrepräsentanz; *It.*: rappresentazione d'azione; *Port.*: representação de acção; *Span.*: representación de acción.

### **action-thought**

*Fr.*: action-pensée (H. Kohut); *Ger.*: Handlungsgedanke *It.*: pensiero-azione; *Port.*: acção-pensamento; *Span.*: acción-pensamiento.

### **active imagination**

*Fr.*: imagination active; *Ger.*: aktive Phantasie; *It.*: immaginazione attiva; *Port.*: imaginação activa; *Span.*: imaginación activa.

### **active technique**

*Fr.*: technique active; *Ger.*: aktive Technik; *It.*: tecnica attiva; *Port.*: técnica activa; *Span.*: técnica activa.

### **activity/passivity**

*Fr.*: activité/passivité; *Ger.*: Aktivität/Passivität *It.*: attività/ passività; *Port.*: actividade/passividade; *Span.*: actividad/pasividad.

### **act, passage to the**

*Fr.*: acte (passage à l'-) ; *Ger.*: Agieren *It.*: passaggio all'atto, agito; *Port.*: passagem ao ato; *Span.*: pasaje al acto.

### **actual**

*Fr.*: actuel; *Ger.*: aktuell *It.*: attuale; *Port.*: actual; *Span.*: actual.

### **actual neurosis/defense neurosis**

*Fr.*: névrose actuelle/névrose de défense; *Ger.*: Aktualneurose/Abwehrneurose; *It.*: nevrosi attuale/ nevrosi da difesa; *Port.*: neurose actual/neurose de defesa; *Span.*: neurosis actual/neurosis de defensa.

### **acute psychoses**

*Fr.*: psychoses aiguës; *Ger.*: akute Psychosen; *It.*: psicosi acute; *Port.*: psicoses agudas. *Span.*: psicosis agudas.

### **adaptation**

*Fr.*: adaptation; *Ger.*: Anpassung *It.*: adattamento; *Port.*: adaptação; *Span.*: adaptación.

### **addiction**

*Fr.*: addiction; *Ger.*: Sucht *It.*: dipendenza; *Port.*: adição a drogas, dependência; *Span.*: adicción.



**adhesive identification**

*Fr.*: identification adhésive; *Ger.*: adhäsive Identifizierung; *It.*: identificazione adesiva; *Port.*: identificação adesiva; *Span.*: identificación adhesiva.

**adolescence**

*Fr.*: adolescence; *Ger.*: Adoleszenz *It.*: adolescenza; *Port.*: adolescência; *Span.*: adolescencia.

**adolescent crisis**

*Fr.*: adolescence (crise d<sup>3</sup>-); *Ger.*: Adoleszenzkrise; *It.*: crisi adolescenziale; *Port.*: crise de adolescência; *Span.*: crisis de adolescencia.

**adoption**

*Fr.*: adoption; *Ger.*: Adoption; *It.*: adozione; *Port.*: adopção; *Span.*: adopción.

**affect**

*Fr.*: affect; *Ger.*: Affekt; *It.*: affetto; *Port.*: afecto; *Span.*: afecto.

**agency**

*Fr.*: instance; *Ger.*: Instanz; *It.*: istanza; *Port.*: instância; *Span.*: instancia.

**aggressiveness**

*Fr.*: agressivité; *Ger.*: Aggressivität; *It.*: aggressività; *Port.*: agressividade; *Span.*: agresividad.

**alchemy**

*Fr.*: alchimie; *Ger.*: Alchimie; *It.*: alchimia; *Port.*: alquimia; *Span.*: alquimia. alcoholism

*Fr.*: alcoolisme; *Ger.*: Alkoholismus; *It.*: alcolismo; *Port.*: alcoolismo; *Span.*: alcoholismo.

**alienation**

*Fr.*: aliénation; *Ger.*: Entfremdung; *It.*: alienazione; *Port.*: alienação; *Span.*: alienación.

**allergy**

*Fr.*: allergie; *Ger.*: Allergie; *It.*: allergia; *Port.*: alergia; *Span.*: alergia.

**allergic relation**

*Fr.*: allergique (relation d'objet -); *Ger.*: allergische Objektbeziehung; *It.*: relazione allergica; *Port.*: relação alérgica; *Span.*: relación alérgica.

**alpha-elements**

*Fr.*: éléments alpha; *Ger.*: Alpha-Elemente; *It.*: elementi alfa; *Port.*: elementos alfa; *Span.*: elementos alfa.

**alpha function**

*Fr.*: fonction alpha; *Ger.*: alpha Funktion; *It.*: funzione alfa; *Port.*: função alfa; *Span.*: función alfa.

**altruism**

*Fr.*: altruisme; *Ger.*: Nächstenliebe/Altruismus; *It.*: altruismo; *Port.*: altruísmo; *Span.*: altruismo.

**ambivalence**

*Fr.*: ambivalence; *Ger.*: Ambivalenz; *It.*: ambivalenza; *Port.*: ambivalência; *Span.*: ambivalencia.

**amnesia**

*Fr.*: amnésie; *Ger.*: Amnesie; *It.*: amnesia; *Port.*: amnésia; *Span.*: amnesia.

**amphimixia**

*Fr.*: amphimixie; *Ger.*: Amphimixis; *It.*: anfimissi; *Port.*: anfimixia; *Span.*: anfimixia.

**amplification**

*Fr.*: amplification; *Ger.*: Amplifikation; *It.*: amplificazione; *Port.*: amplificação; *Span.*: amplificación.

**anaclisis/anaclitic**

*Fr.*: anaclitisme, anaclitique; *Ger.*: Anaklitismus, anaklitisch; *It.*: anaclisi, anaclitico; *Port.*: anaclitismo, anaclítico; *Span.*: anaclitismo, anaclítico.

**anagogical interpretation**

*Fr.*: interprétation anagogique; *Ger.*: anagogische Deutung; *It.*: interpretazione anagogica; *Port.*: interpretação anagógica; *Span.*: interpretación anagógica.

**anal eroticism**

*Fr.*: érotisme anal; *Ger.*: Analerotik; *It.*: erotismo anale; *Port.*: erotismo anal; *Span.*: erotismo anal.

**anality**

*Fr.*: analité; *Ger.*: Analität; *It.*: analità; *Port.*: analidade; *Span.*: analidad.

**anal-sadistic stage**

*Fr.*: stade sadique-anal; *Ger.*: anal(sadistische) Phase; *It.*: fase sadico-anale; *Port.*: fase anal-sádica; *Span.*: fase sádico-anal.

**analysability**

*Fr.*: analysabilité; *Ger.*: Analysierbarkeit; *It.*: analizzabilità; *Port.*: analisabilidade; *Span.*: analisabilidad.

**analysand**

*Fr.*: analysé/analysant; *Ger.*: analysiert/analysierend, der Analysand; *It.*: analizzato/analizzando; *Port.*: analisado/analisante; *Span.*: analizado/analizante.

**analytical psychology**

*Fr.*: psychologie analytique; *Ger.*: analytische Psychologie; *It.*: psicologia analitica; *Port.*: psicologia analítica; *Span.*: psicología analítica.

**animal magnetism**

*Fr.*: magnétisme animal; *Ger.*: animalischer Magnetismus; *It.*: magnetismo animale; *Port.*: magnetismo animal; *Span.*: magnetismo animal.

**animistic thought**

*Fr.*: animique (pensée -); *Ger.*: animistisches Denken; *It.*: pensiero animistico; *Port.*: pensamento animista; *Span.*: pensamiento animista.

**annihilation anxiety**

*Fr.*: angoisses d'anéantissement; *Ger.*: Vernichtungssangst; *It.*: angoscia di annichilimento; *Port.*: angústias de aniquilamento; *Span.*: angustias de aniquilamiento.

**anorexia nervosa**

*Fr.*: anorexie mentale; *Ger.*: Anorexie; *It.*: anoressia mentale; *Port.*: anorexia mental; *Span.*: anorexia nerviosa.

**anticathexis, counter-cathexis**

*Fr.*: contre-investissement; *Ger.*: Gegenbesetzung; *It.*: controinvestimento; *Port.*: contra-investimento; *Span.*: contracarga.

**anticipatory ideas**

*Fr.*: représentations d'attente; *Ger.*: Erwartungsvorstellungen; *It.*: rappresentazioni anticipatorie; *Port.*: representação de espera; *Span.*: representaciones de espera.

**antilibidinal ego/internal saboteur**

*Fr.*: ego antilibidinal/saboteur interne; *Ger.*: antilibidinöses Ich/innerer Saboteur; *It.*: Io antilibidico/sabotatore interno; *Port.*: Eu anti-libidinal/ sabotador interno; *Span.*: Yo antilibidinal/saboteador interno.

**antinarcissism**

*Fr.*: anti-narcissisme; *Ger.*: Antinarzissmus; *It.*: antinarcisismo; *Port.*: antinarcisismo; *Span.*: antinarcisismo.

**anxiety**

*Fr.*: angoisse; *Ger.*: Angst; *It.*: angoscia; *Port.*: angústia; *Span.*: angustia.

**anxiety dream**

*Fr.*: rêve d'angoisse; *Ger.*: Angsttraum; *It.*: sogno di angoscia; *Port.*: sonho de angústia; *Span.*: sueño de angustia.

**aphanisis**

*Fr.*: aphanisis; *Ger.*: Aphanisis; *It.*: afanisi; *Port.*: afânise; *Span.*: afánisis.

**aphasia**

*Fr.*: aphasie; *Ger.*: Aphasie; *It.*: afasia; *Port.*: afasia; *Span.*: afasia.

**archaic**

*Fr.*: archaïque; *Ger.*: archaisch; *It.*: arcaico; *Port.*: arcaico; *Span.*: arcaico.

**archaic mother**

*Fr.*: mère archaïque; *Ger.*: archaische Mutter; *It.*: madre arcaica; *Port.*: mãe arcaica; *Span.*: madre arcaica.

**archetype**

*Fr.*: archétype; *Ger.*: Archetyp; *It.*: archetipo; *Port.*: arquétipo; *Span.*: arquetipo.

**arrogance**

*Fr.*: arrogance; *Ger.*: Arroganz; *It.*: arroganza; *Port.*: arrogância; *Span.*: arrogancia.

**as if personality**

*Fr.*: comme si (personnalité -); *Ger.*: Als-ob-Persönlichkeit; *It.*: personalità come se; *Port.*: personalidade como se; *Span.*: personalidad como si.

**attachment**

*Fr.*: attachement; *Ger.*: Bindung; *It.*: attaccamento; *Port.*: apego; *Span.*: apego.

**attention**

*Fr.*: attention; *Ger.*: Beachtung/Aufmerksamkeit; *It.*: attenzione; *Port.*: atenção; *Span.*: atención.

**autism**

*Fr.*: autisme; *Ger.*: Autismus; *It.*: autismo; *Port.*: autismo; *Span.*: autismo.

**autistic capsule/autistic nucleus**

*Fr.*: noyau autistique; *Ger.*: autistischer Kern; *It.*: nucleo autistico; *Port.*: núcleo autístico; *Span.*: núcleo autista.

**autistic defenses**

*Fr.*: défenses autistiques; *Ger.*: autistische Abwehr(mechanismen); *It.*: difese autistiche; *Port.*: defesas autísticas; *Span.*: defensas autísticas.

**autobiography**

*Fr.*: autobiographie; *Ger.*: Autobiographie; *It.*: autobiografia; *Port.*: autobiografia; *Span.*: autobiografía.

**autoeroticism/alloeroticism**

*Fr.*: autoérotisme/alloérotisme; *Ger.*: Autoerotismus/Alloerotismus; *It.*: autoerotismo/alloerotismo; *Port.*: auto-erotismo/alo-erotismo; *Span.*: autoerotismo/alloerotismo.

**automatism**

*Fr.*: automatisme; *Ger.*: Automatismus; *It.*: automatismo; *Port.*: automatismo; *Span.*: automatismo.

**autoplastic/alloplastic**

*Fr.*: autoplastique/alloplastique; *Ger.*: autoplastisch/alloplastisch; *It.*: autoplastico/alloplastico; *Port.*: autoplástico/aloplástico; *Span.*: autoplástico/aloplástico.

**autosuggestion**

*Fr.*: autosuggestion; *Ger.*: Autosuggestion; *It.*: autosuggerione; *Port.*: auto-sugestão; *Span.*: autosugestión.

**basic assumption**

*Fr.*: présupposé de base; *Ger.*: “basic assumption”/Grundannahme; *It.*: assunto di base; *Port.*: pressuposto de base; *Span.*: presupuesto de base.

**basic fault**

*Fr.*: défaut fondamental; *Ger.*: Grundstörung; *It.*: difetto fondamentale; *Port.*: falha básica; *Span.*: falla básica.

**belief**

*Fr.*: croyance; *Ger.*: Glaube; *It.*: credenza; *Port.*: crença; *Span.*: creencia.

**benign/malignant regression**

*Fr.*: régression bénigne/maligne; *Ger.*: benigne/maligne Regression; *It.*: regressione benigna/maligna; *Port.*: regressão benigna/maligna; *Span.*: regresión benigna/maligna.

**beta-elements**

*Fr.*: éléments bêta; *Ger.*: Beta-Elemente; *It.*: elementi beta; *Port.*: elementos beta; *Span.*: elementos beta.

**beta screen**

*Fr.*: écran bêta; *Ger.*: Betaschirm; *It.*: schermo beta; *Port.*: ecrã beta; *Span.*: pantalla beta.

**binding/unbinding**

*Fr.*: liaison/déliaison; *Ger.*: Bindung/Entbindung; *It.*: legame/slegamento; *Port.*: união/desunião; *Span.*: unión/desunión.

**biological bedrock**

*Fr.*: roc du biologique; *Ger.*: biologisches Fundament/gewachsener Fels; *It.*: roccia basilare del biologico; *Port.*: fundo biológico; *Span.*: roca de base/roca viva.

**bipolar self**

*Fr.*: Self bipolaire; *Ger.*: bipolares Selbst; *It.*: Sé bipolare; *Port.*: self bipolar; *Span.*: self bipolar.

**birth**

*Fr.*: naissance; *Ger.*: Geburt; *It.*: nascita; *Port.*: nascimento. *Span.*: nacimiento.

**birth, dream of**

*Fr.*: rêve de naissance; *Ger.*: Geburtstraum; *It.*: sogno di nascita; *Port.*: sonho de nascimento; *Span.*: sueño de nacimiento.

**bisexuality**

*Fr.*: bisexualité; *Ger.*: Bisexualität; *It.*: bisessualità; *Port.*: bissexualidade; *Span.*: bisexualidad.

**bizarre object**

*Fr.*: objet bizarre; *Ger.*: bizarres Objekt; *It.*: oggetto bizzarro; *Port.*: objecto bizarro; *Span.*: objeto bizarro.

**black hole**

*Fr.*: trou noir; *Ger.*: schwarzes Loch; *It.*: buco nero; *Port.*: buraco negro; *Span.*: agujero negro.

**blank psychosis**

*Fr.*: psychose blanche; *Ger.*: “Blanko” Psychose; *It.*: psicosi bianca; *Port.*: psicose branca. *Span.*: psicosis blanca.

**body image**

*Fr.*: image du corps; *Ger.*: Körperbild; *It.*: immagine corporea; *Port.*: imagem corporal; *Span.*: imagen corporal.

**borderline conditions**

*Fr.*: états limites; *Ger.*: Borderline-Zustände; *It.*: stati limite/ borderline; *Port.*: estados limites; *Span.*: estados fronterizos.

**boredom**

*Fr.*: ennui; *Ger.*: Langweile; *It.*: noia; *Port.*: aborrecimento; *Span.*: aburrimiento.

**boundary violations**

*Fr.*: limites (violation des -); *Ger.*: Grenzverletzungen; *It.*: violazione dei limiti; *Port.*: violação dos limites; *Span.*: violación de los límites.

**breakdown**

*Fr.*: effondrement; *Ger.*: Zusammenbruch; *It.*: crollo; *Port.*: desmonoramento. *Span.*: desmoronamiento.

**breaking through the protective shield**

*Fr.*: pare-excitations (effraction du -); *Ger.*: Durchbruch des Reizschutzes; *It.*: effrazione del parastimoli o schermo antistimolo; *Port.*: efracção do pára-excitações; *Span.*: efracción del protector contra las excitaciones.

**breastfeeding**

*Fr.*: allaitement; *Ger.*: Stillen; *It.*: allattamento; *Port.*: aleitamento; *Span.*: amamantamiento.

**breast, good/bad object**

*Fr.*: objet ou sein (bon/mauvais); *Ger.*: Objekt oder Brust (gut/bös); *It.*: oggetto o seno (buono/cattivo); *Port.*: objecto ou seio (bom/mau); *Span.*: objeto o pecho (bueno/malo).

**bulimia**

*Fr.*: boulimie; *Ger.*: Bulimie; *It.*: bulimia; *Port.*: bulimia; *Span.*: bulimia.

**capacity for being alone**

*Fr.*: capacité d'être seul; *Ger.*: Fähigkeit zum Alleinsein; *It.*: capacità di stare solo; *Port.*: capacidade de ficar só; *Span.*: capacidad de estar solo.

**capacity for maternal reverie**

*Fr.*: rêverie maternelle (capacité de -); *Ger.*: Fähigkeit der Mutter zur Tagträumerei; *Ital.*: capacità di rêverie materna; *Port.*: capacidade da mãe devanear; *Span.*: capacidad de "rêverie" de la madre.

**castration**

*Fr.*: castration; *Ger.*: Kastration; *It.*: castrazione; *Port.*: castração; *Span.*: castración.

**castration complex**

*Fr.*: castration (complexe de -); *Ger.*: Kastrationskomplex; *It.*: complesso di castrazione; *Port.*: complexo de castração; *Span.*: complejo de castración.

**catastrophic change**

*Fr.*: changement catastrophique; *Ger.*: katastrophische Veränderung; *It.*: cambiamento catastrofico; *Port.*: alteração catastrófica; *Span.*: cambio catastrófico.

**cathartic method**

*Fr.*: cathartique (méthode -); *Ger.*: kathartische Methode; *It.*: metodo catartico; *Port.*: método catártico; *Span.*: método catártico.

**cathectic energy**

*Fr.*: énergie d'investissement; *Ger.*: Besetzungsenergie; *Ital.*: energia d'investimento; *Port.*: energia de investimento; *Span.*: energía de investidura/carga.

**cathexis**

*Fr.*: investissement; *Ger.*: Besetzung; *Ital.*: investimento; *Port.*: investimento; *Span.*: carga/investidura.

**censorship**

*Fr.*: censure; *Ger.*: Zensur; *It.*: censura; *Port.*: censura; *Span.*: censura.

**certainty**

*Fr.*: certitude; *Ger.*: Gewissheit; *It.*: certezza; *Port.*: certeza; *Span.*: certeza.

**change**

*Fr.*: changement; *Ger.*: Veränderung; *It.*: cambiamento; *Port.*: mudança; *Span.*: cambio.

**character**

*Fr.*: caractère; *Ger.*: Charakter; *It.*: carattere; *Port.*: caráter; *Span.*: carácter.

**character formation**

*Fr.*: caractère (formation du -); *Ger.*: Charakterbildung; *It.*: formazione del carattere; *Port.*: formação do caráter; *Span.*: formación del carácter.

**character neurosis**

*Fr.*: caractère (névrose de -); *Ger.*: Charakterneurose; *It.*: nevrosi del carattere; *Port.*: neurose de caráter; *Span.*: neurosis de carácter.

**child analysis**

*Fr.*: psychanalyse de l'enfant; *Ger.*: Kinderanalyse; *Ital.*: psicoanalisi del bambino/infantile; *Port.*: psicanálise da criança; *Span.*: psicoanálisis del niño.

**childhood**

*Fr.*: enfance; *Ger.*: Kindheit; *Ital.*: infanzia; *Port.*: infância; *Span.*: infancia.

**children's play**

*Fr.*: jeu de l'enfant; *Ger.*: Spiel des Kindes; *Ital.*: gioco infantile; *Port.*: brincadeira da criança; *Span.*: juego del niño.

**choice of neurosis**

*Fr.*: névrose (choix de la -); *Ger.*: Neurosenwahl; *Ital.*: scelta della nevrosi; *Port.*: escolha da neurose; *Span.*: elección de la neurosis.

**civilization (Kultur)**

*Fr.*: civilisation (Kultur); *Ger.*: Zivilisation/Kultur; *It.*: civiltà/cultura; *Port.*: civilização/cultura; *Span.*: civilización/cultura.

**claustrophobia**

*Fr.*: claustrophobie; *Ger.*: Klaustrophobie; *It.*: claustrofobia; *Port.*: claustrofobia; *Span.*: claustrofobia.

**clinging instinct**

*Fr.*: cramponnement (instinct de -); *Ger.*: Anklammerungstrieb; *It.*: istinto di aggrappamento; *Port.*: impulso de agarrar; *Span.*: instinto de aferrar.

**collective psychology**

*Fr.*: psychologie collective; *Ger.*: kollektive Psychologie; *Ital.*: psicologia collettiva; *Port.*: psicologia colectiva; *Span.*: psicología colectiva.

**collective unconscious**

*Fr.*: inconscient collectif; *Ger.*: das kollektive Unbewusste; *Ital.*: inconscio collettivo; *Port.*: inconsciente colectivo; *Span.*: inconsciente colectivo.

**combined parent figure**

*Fr.*: parents combinés (figure des -); *Ger.*: vereinigte Elternfigur; *Ital.*: figura parentale combinata; *Port.*: figura dos pais combinados; *Span.*: figura de los padres combinados.

**compensation**

*Fr.*: compensation; *Ger.*: Kompensation; *It.*: compensazione; *Port.*: compensação; *Span.*: compensación.

**compensatory structures**

*Fr.*: structures compensatrices; *Ger.*: kompensatorische Strukturen; *Ital.*: strutture compensatorie; *Port.*: estruturas compensatórias; *Span.*: estructuras compensatorias.

**complementary series**

*Fr.*: série complémentaire; *Ger.*: Ergänzungsreihe; *Ital.*: serie complementare; *Port.*: série complementar; *Span.*: serie complementaria.

**complex**

*Fr.*: complexe; *Ger.*: Komplex; *It.*: complesso; *Port.*: complexo; *Span.*: complejo.

**compromise formation**

*Fr.*: formation de compromis; *Ger.*: Kompromissbildung; *Ital.*: formazione di compromesso; *Port.*: formação de compromisso; *Span.*: formación de compromiso.

**compulsion**

*Fr.*: compulsion (ou contrainte); *Ger.*: Zwang; *It.*: coazione; *Port.*: compulsão; *Span.*: compulsión.

**concept**

*Fr.*: conception, concept; *Ger.*: Konzeption, Konzept; *It.*: concezione, concetto; *Port.*: concepção, conceito; *Span.*: concepción, concepto.

**condensation**

*Fr.*: condensation; *Ger.*: Verdichtung; *It.*: condensazione; *Port.*: condensação; *Span.*: condensación.

**conflict**

*Fr.*: conflit; *Ger.*: Konflikt; *It.*: conflitto; *Port.*: conflito; *Span.*: conflicto.

**consciousness**

*Fr.*: Conscient (le)/conscience; *Ger.*: das Bewusste/Bewusstsein; *It.*: il Conscio/coscienza; *Port.*: consciente/consciência; *Span.*: el consciente/consciencia.

**conscious processes**

*Fr.*: processus conscients; *Ger.*: bewusste Vorgänge; *Ital.*: processi consci; *Port.*: processos conscientes; *Span.*: procesos conscientes.

**constitution**

*Fr.*: constitution; *Ger.*: Konstitution; *It.*: costituzione; *Port.*: constituição; *Span.*: constitución.

**construction-reconstruction**

*Fr.*: construction-reconstruction; *Ger.*: Konstruktion-Rekonstruktion; *It.*: costruzione-ricostruzione; *Port.*: construção-reconstrução; *Span.*: construcción-reconstrucción.

**contact**

*Fr.*: contact; *Ger.*: Kontakt, Berührung; *It.*: contatto; *Port.*: contacto; *Span.*: contacto.

**contact-barrier**

*Fr.*: barrière de contact; *Ger.*: Kontaktschranke; *Ital.*: barriera di contatto; *Port.*: barreira de contacto; *Span.*: barrera de contacto.

**container-contained**

*Fr.*: contenant-contenu; *Ger.*: container-contained; *It.*: contenitore-contenuto; *Port.*: continente-conteúdo; *Span.*: continente-contenido.

**contradiction**

*Fr.*: contradiction; *Ger.*: Widerspruch; *It.*: contraddizione; *Port.*: contradição; *Span.*: contradicción.

**control-analysis**

*Fr.*: contrôle (psychanalyse sous -); *Ger.*: Kontrollanalyse; *It.*: psicoanalisi sotto supervisione; *Port.*: psicanálise sob supervisão; *Span.*: psicoanálisis de control supervisión.

**convenience, dream of**

*Fr.*: rêve de commodité; *Ger.*: Bequemlichkeitstraum; *It.*: sogno di comodità; *Port.*: sonho de conveniência; *Span.*: sueño de comodidad.

**conversion**

*Fr.*: conversion; *Ger.*: Konversion; *It.*: conversione; *Port.*: conversão; *Span.*: conversión.

**coprophilia**

*Fr.*: coprophilie; *Ger.*: Koprophilie; *It.*: coprofilia; *Port.*: coprofilia; *Span.*: coprofilia.

**counterphobic**

*Fr.*: contraphobique; *Ger.*: contraphobisch; *It.*: contro-fobico; *Port.*: contra-fóbico; *Span.*: contrafóbico.

**counter-identification**

*Fr.:* contre-identification; *Ger.:* Gegenidentifizierung; *It.:* controidentificazione; *Port.:* contra-identificação; *Span.:* contraidentificación.

**counter-transference**

*Fr.:* contre-transfert; *Ger.:* Gegenübertragung; *It.:* controtrasfert; *Port.:* contratransferência; *Span.:* contratransferencia.

**creativity**

*Fr.:* créativité; *Ger.:* Kreativität; *It.:* creatività; *Port.:* criatividade; *Span.:* creatividad.

**cruelty**

*Fr.:* cruauté; *Ger.:* Grausamkeit; *Ital.:* crudeltà; *Port.:* crueldade; *Span.:* crueldad.

**cryptomnesia**

*Fr.:* cryptomnésie; *Ger.:* Kryptomnesie; *Ital.:* criptomnesia; *Port.:* criptomnésia; *Span.:* criptomnesia.

**cultural transmission**

*Fr.:* transmission culturelle; *Ger.:* kulturelle Übertragung; *Ital.:* trasmissione culturale; *Port.:* transmissão cultural; *Span.:* transmisión cultural.

**cure**

*Fr.:* guérison; *Ger.:* Heilung; *Ital.:* guarigione; *Port.:* cura; *Span.:* curación.

**danger**

*Fr.:* danger; *Ger.:* Gefahr; *It.:* pericolo; *Port.:* perigo; *Span.:* peligro.

**dark continent**

*Fr.:* continent noir; *Ger.:* schwarzer Kontinent; *It.:* continente nero; *Port.:* continente negro; *Span.:* continente negro.

**day's residues**

*Fr.:* restes diurnes; *Ger.:* Tagesreste; *It.:* resti diurni; *Port.:* restos diurnos. *Span.:* restos diurnos.

**death instinct**

*Fr.:* pulsion de mort; *Ger.:* Todestrieb; *It.:* pulsione di morte; *Port.:* pulsão de morte. *Span.:* pulsión de muerte.

**decathexis**

*Fr.:* désinvestissement; *Ger.:* Entziehung der Besetzung/Unbesetztheit; *It.:* disinvestimento; *Port.:* desinvestimento; *Span.:* desinvestimento.

**defense mechanisms**

*Fr.:* défense (mécanismes de -); *Ger.:* Abwehrmechanismen; *It.:* meccanismi di difesa; *Port.:* mecanismos de defesa; *Span.:* mecanismos de defensa.

**defenses**

*Fr.:* défenses; *Ger.:* Abwehr(mechanismen); *It.:* difese; *Port.:* defesas; *Span.:* defensas.

**deferred action**

*Fr.:* après-coup; *Ger.:* Nachträglichkeit, nachträglich; *It.:* posteriorità, posteriormente; *Port.:* só depois/a posteriori; *Span.:* a posteriori, acción retardada, aplazada.

**déjà-vu**

*Fr.:* déjà-vu; *Ger.:* Déjà-vu; *It.:* déjà-vu; *Port.:* déjà-vu; *Span.:* déjà-vu.

**delusion**

*Fr.:* délire; *Ger.:* Wahn; *It.:* delirio; *Port.:* delírio; *Span.:* delirio.

**demand**

*Fr.:* demande; *Ger.:* Forderung; *It.:* domanda; *Port.:* demanda; *Span.:* demanda.

**dementia**

*Fr.:* démence; *Ger.:* Wahnsinn; *It.:* demenza; *Port.:* demência; *Span.:* demencia.

**dependence**

*Fr.:* dépendance; *Ger.:* Abhängigkeit; *It.:* dipendenza; *Port.:* dependência; *Span.:* dependencia.

**depersonalization**

*Fr.:* dépersonnalisation; *Ger.:* Depersonalisation, Entfremdungserlebnis; *It.:* depersonalizzazione; *Port.:* despersionalização; *Span.:* despersonalización.

**deprivation**

*Fr.:* carence; *Ger.:* Fehlen/Mangel; *It.:* carenza; *Port.:* carência; *Span.:* carencia.

**determinism**

*Fr.:* déterminisme; *Ger.:* Determinismus; *It.:* determinismo; *Port.:* determinismo; *Span.:* determinismo.

**developmental disorders**

*Fr.:* développement (troubles du -); *Ger.:* Entwicklungsstörungen; *It.:* disturbi evolutivi; *Port.:* transtornos desenvolvimento; *Span.:* trastornos del desarrollo.

**developmental process**

*Fr.:* développement (processus de -); *Ger.:* Entwicklungsprozess; *It.:* processo di sviluppo; *Port.:* processo de desenvolvimento; *Span.:* proceso de desarrollo.

**dipsomania**

*Fr.:* dipsomanie; *Ger.:* Trunksucht, Dipsomanie; *It.:* dipsomania; *Port.:* dipsomania; *Span.:* dipsomanía.

**direct analysis**

*Fr.:* analyse directe; *Ger.:* direkte Analyse; *It.:* analisi diretta; *Port.:* análise directa; *Span.:* análisis directo.

**discharge**

*Fr.*: décharge; *Ger.*: Abfuhr; *It.*: scarica, deflusso; *Port.*: descarga; *Span.*: descarga.

**disintegration products**

*Fr.*: produits de désintégration; *Ger.*: Zerfallsprodukte; *It.*: prodotti di disintegrazione; *Port.*: produtos de desintegração; *Span.*: productos de desintegración.

**dismantling**

*Fr.*: démantèlement; *Ger.*: Zerfall, Zerfallenlassen; *It.*: smantellamento; *Port.*: desmantelamento; *Span.*: desmantelamiento.

**disorganization**

*Fr.*: désorganisation; *Ger.*: Desorganisation; *It.*: disorganizzazione; *Port.*: desorganização; *Span.*: desorganización.

**displacement**

*Fr.*: déplacement; *Ger.*: Verschiebung; *It.*: spostamento; *Port.*: deslocamento; *Span.*: desplazamiento.

**displacement of the transference**

*Fr.*: transfert latéral; *Ger.*: Nebenübertragung; *It.*: transfert laterale; *Port.*: transferência lateral; *Span.*: transferencia lateral.

**double**

*Fr.*: double (le); *Ger.*: Doppelgänger; *It.*: doppio; *Port.*: duplo; *Span.*: doble.

**double bind**

*Fr.*: double lien; *Ger.*: double bind; *It.*: doppio legame; *Port.*: vínculo duplo; *Span.*: doble vínculo.

**doubt**

*Fr.*: doute; *Ger.*: Zweifel; *It.*: dubbio; *Port.*: dúvida; *Span.*: duda.

**dream**

*Fr.*: rêve; *Ger.*: Traum; *It.*: sogno; *Port.*: sonho; *Span.*: sueño.

**dream interpretation**

*Fr.*: rêve (interprétation du -); *Ger.*: Traumdeutung; *It.*: interpretazione del sogno; *Port.*: interpretação do sonho; *Span.*: interpretación del sueño.

**dream screen**

*Fr.*: rêve (écran du -); *Ger.*: Projektionsfläche des Traumes, Traumschirm; *It.*: schermo del sogno; *Port.*: ecrã do sonho; *Span.*: pantalla del sueño.

**dream symbolism**

*Fr.*: symbolisme du rêve; *Ger.*: Traumsymbolik; *It.*: simbolismo del sogno; *Port.*: simbolismo do sonho; *Span.*: simbolismo del sueño.

**dream work**

*Fr.*: rêve (travail du -); *Ger.*: Traumarbeit; *It.*: lavoro del sogno; *Port.*: trabalho do sonho; *Span.*: trabajo del sueño.

**dream's navel**

*Fr.*: ombilic du rêve; *Ger.*: Nabel des Traums; *It.*: ombelico del sogno; *Port.*: umbigo do sonho; *Span.*: ombligo del sueño.

**dualism**

*Fr.*: dualisme; *Ger.*: Dualismus; *It.*: dualismo; *Port.*: dualismo; *Span.*: dualismo.

**dynamic point of view**

*Fr.*: dynamique (point de vue -); *Ger.*: dynamischer Gesichtspunkt; *It.*: punto di vista dinamico; *Port.*: ponto de vista dinâmico; *Span.*: punto de vista dinámico.

**early interactions**

*Fr.*: interactions précoces; *Ger.*: frühe Interaktionen; *It.*: interazioni precoci; *Port.*: interações precoces; *Span.*: interacciones precoces.

**early Oedipus complex**

*Fr.*: complexe d'Édipe précoce; *Ger.*: früher Ödipuskomplex; *It.*: complesso edipico precoce; *Port.*: complexo de Édipo precoce; *Span.*: complejo de Edipo temprano.

**economic point of view**

*Fr.*: économique (point de vue -); *Ger.*: ökonomischer Gesichtspunkt; *It.*: punto di vista economico; *Port.*: ponto de vista econômico; *Span.*: punto de vista económico.

**ego**

*Fr.*: Moi; *Ger.*: Ich; *It.*: Io; *Port.*: Eu; *Span.*: Yo.

**ego, alterations of the**

*Fr.*: Moi (altérations du -); *Ger.*: Ichveränderung; *It.*: alterazioni dell'Io; *Port.*: alterações do Eu; *Span.*: alteraciones del Yo.

**ego autonomy**

*Fr.*: Moi (autonomie du -); *Ger.*: Ichautonomie; *It.*: autonomia dell'Io; *Port.*: autonomia do Eu; *Span.*: autonomía del Yo.

**ego boundaries**

*Fr.*: Moi (limites du -); *Ger.*: Ichgrenzen; *It.*: limiti dell'Io; *Port.*: limites do Eu; *Span.*: límites del Yo.

**ego, damage inflicted on the**

*Fr.*: Moi (dommages infligés au -); *Ger.*: Ichbeschädigungen; *It.*: danni inflitti all'Io; *Port.*: danos infligidos ao Eu; *Span.*: daños infligidos al Yo.

**ego feeling**

*Fr.*: Moi (sentiment du -); *Ger.*: Ichgefühl; *It.*: sentimento dell'Io; *Port.*: sentimento do Eu; *Span.*: sentimiento del Yo.

**ego functions**

*Fr.*: Moi (fonctions du -); *Ger.*: Ichfunktionen; *It.*: funzioni dell'Io; *Port.*: funções do Eu; *Span.*: funciones del Yo.

**ego interests**

*Fr.*: Moi (intérêts du -); *Ger.*: Ichinteressen; *It.*: interessi dell'Io; *Port.*: interesses do Eu; *Span.*: intereses del Yo.

**ego-instinct**

*Fr.*: pulsions du Moi; *Ger.*: Ichtriebe; *Span.*: pulsiones del Yo; *It.*: pulsioni dell'Io; *Port.*: pulsões do Eu.

**ego ideal**

*Fr.*: Idéal du Moi; *Ger.*: Ichideal; *It.*: ideale dell'Io; *Port.*: ideal do Eu; *Span.*: ideal del Yo.

**ego identity**

*Fr.*: identité du Moi; *Ger.*: Ichidentität; *It.*: identità dell'Io; *Port.*: identidade do Eu; *Span.*: identidad del Yo.

**ego-libido/object-libido**

*Fr.*: libido du Moi (narcissique)/libido objectale; *Ger.*: Ichlibido/Objektlibido; *It.*: libido dell'Io/libido oggettuale; *Port.*: libido do Eu (narcísico)/libido objetal; *Span.*: libido del Yo (narcisista)/libido objetal.

**ego states**

*Fr.*: Moi (états du -); *Ger.*: Ichzustände; *It.*: stati dell'Io; *Port.*: estados do Eu; *Span.*: estados del Yo.

**ego-syntonic**

*Fr.*: Moi (conformité au -, egosyntonie); *Ger.*: Ichübereinstimmung, Ichgerechtheit; *It.*: concordanza con l'Io, egosintonia; *Port.*: conformidade com o Eu, ego-sintonia; *Span.*: conformidad al Yo, egosintonía.

**elasticity**

*Fr.*: élasticité (technique d'-); *Ger.*: Elastizität; *It.*: elasticità; *Port.*: elasticidade; *Span.*: elasticidad.

**emotion**

*Fr.*: émotion; *Ger.*: Emotion; *It.*: emozione; *Port.*: emoção; *Span.*: emoción.

**empathy**

*Fr.*: empathie; *Ger.*: Einfühlung; *It.*: empatia; *Port.*: empatia; *Span.*: empatía.

**encopresis**

*Fr.*: encoprésie; *Ger.*: Enkopresie; *It.*: encopresi; *Port.*: encoprese; *Span.*: encopresis.

**encounter**

*Fr.*: rencontre; *Ger.*: Begegnung; *It.*: incontro; *Port.*: encontro; *Span.*: encuentro.

**energy**

*Fr.*: énergie; *Ger.*: Energie; *It.*: energia; *Port.*: energia; *Span.*: energía.

**enuresis**

*Fr.*: énurésie; *Ger.*: Enuresis nocturna/Bettnässen; *It.*: enuresi; *Port.*: enurese; *Span.*: enuresis.

**envy**

*Fr.*: envie; *Ger.*: Neid; *It.*: invidia; *Port.*: inveja; *Span.*: envidia.

**erogeneity**

*Fr.*: érogénéité; *Ger.*: Erogenität; *It.*: erogenità; *Port.*: erogeneidade; *Span.*: erogeneidad.

**erotogenic masochism**

*Fr.*: masochisme érogène; *Ger.*: erogener Masochismus; *It.*: masochismo erogeno; *Port.*: masoquismo erógeno; *Span.*: masoquismo erógeno.

**erotogenic zone**

*Fr.*: zone érogène; *Ger.*: erogene Zone; *It.*: zona erogena; *Port.*: zona erógena; *Span.*: zona erógena.

**erotomania**

*Fr.*: érotomanie; *Ger.*: Erotomanie; *It.*: erotomania; *Port.*: erotomania; *Span.*: erotomanía.

**essential depression**

*Fr.*: dépression essentielle; *Ger.*: genuine Depression; *It.*: depressione essenziale; *Port.*: depressão essencial; *Span.*: depresión esencial.

**estrangement**

*Fr.*: étrangeté (sentiment d'-); *Ger.*: Entfremdungsgefühl; *It.*: sentimento di estraneità; *Port.*: sentimento de estranheza. *Span.*: sentimiento de extrañeza.

**ethnopschoanalysis**

*Fr.*: ethnopsychanalyse; *Ger.*: Ethnopschoanalyse; *It.*: etnopsicoanalisi; *Port.*: etnopsicanálise; *Span.*: etnopsicoanálisis.

**evenly-suspended attention**

*Fr.*: attention (également) flottante; *Ger.*: gleichschwebende Aufmerksamkeit; *It.*: attenzione (liberamente) fluttuante; *Port.*: atenção flutuante; *Span.*: atención (parejamente) flotante.



**examination dream**

*Fr.*: rêve d'examen; *Ger.*: Prüfungstraum; *It.*: sogno di esame; *Port.*: sonho de exame; *Span.*: sueño de examen.

**excitation**

*Fr.*: excitation; *Ger.*: Erregung; *It.*: eccitamento; *Port.*: excitação; *Span.*: excitación.

**exhibitionism**

*Fr.*: exhibitionnisme; *Ger.*: Exhibitionismus; *It.*: esibizionismo; *Port.*: exibicionismo; *Span.*: exhibicionismo.

**experience of satisfaction**

*Fr.*: expérience de satisfaction; *Ger.*: Befriedigungserlebnis; *It.*: esperienza di soddisfazione; *Port.*: experiência de satisfação; *Span.*: vivencia de satisfacción.

**externalization-internalization**

*Fr.*: externalisation-internalisation; *Ger.*: Veräußerlichung-Verinnerlichung; *It.*: esternalizzazione-internalizzazione; *Port.*: externalização-intervalização; *Span.*: externalización-intervalización.

**extraversion/introversion**

*Fr.*: extraversion/introversion; *Ger.*: Extraversion/Introversion; *It.*: estroversione/introversione; *Port.*: extraversão/introversão; *Span.*: extroversión/introversión.

**face-to-face situation**

*Fr.*: face-à-face (situation de); *Ger.*: Situation im Gegenübersitzen; *It.*: vis-à-vis; *Port.*: situação de face a face; *Span.*: situación de frente a frente.

**facilitation**

*Fr.*: frayage; *Ger.*: Bahnung; *It.*: facilitazione; *Port.*: facilitação; *Span.*: facilitación.

**failure neurosis**

*Fr.*: névrose d'échec; *Ger.*: Misserfolgsneurose; *It.*: nevrosi di scacco; *Port.*: neurose de fracasso; *Span.*: neurosis de fracaso.

**false self**

*Fr.*: faux Self; *Ger.*: falsches Selbst; *It.*: falso Sé; *Port.*: falso self; *Span.*: falso self.

**family**

*Fr.*: famille; *Ger.*: Familie; *It.*: famiglia; *Port.*: família; *Span.*: familia.

**family romance**

*Fr.*: roman familial; *Ger.*: Familienroman; *It.*: romanzo familiare; *Port.*: romance familiar; *Span.*: novela familiar.

**fantasy (reverie)**

*Fr.*: fantaisie; *Ger.*: Phantasie; *It.*: fantasia; *Port.*: fantasia; *Span.*: fantasía.

**fantasy/phantasy**

*Fr.*: fantasme; *Ger.*: Phantasie; *It.*: fantasia/fantasma; *Port.*: fantasma/fantasia; *Span.*: fantasma.

**fascination**

*Fr.*: fascination; *Ger.*: Faszination; *It.*: fascinazione; *Port.*: fascinação; *Span.*: fascinación.

**fate neurosis**

*Fr.*: névrose de destinée; *Ger.*: Schicksalsneurose; *It.*: nevrosi di destino; *Port.*: neurose de destino; *Span.*: neurosis de destino.

**father complex**

*Fr.*: complexe paternel; *Ger.*: Vaterkomplex; *It.*: complesso paterno; *Port.*: complexo paterno; *Span.*: complejo paterno.

**fatherhood**

*Fr.*: paternité; *Ger.*: Vaterschaft; *It.*: paternità; *Port.*: paternidade; *Span.*: paternidad.

**fear**

*Fr.*: peur; *Ger.*: Furcht; *It.*: paura; *Port.*: medo; *Span.*: miedo.

**feces**

*Fr.*: fèces; *Ger.*: Faeces/Kot; *It.*: feci; *Port.*: fezes; *Span.*: heces.

**feminine masochism**

*Fr.*: masochisme féminin; *Ger.*: weiblicher Masochismus; *It.*: masochismo femminile; *Port.*: masoquismo feminino; *Span.*: masoquismo femenino.

**feminine sexuality**

*Fr.*: sexualité féminine; *Ger.*: weibliche Sexualität; *It.*: sessualità femminile; *Port.*: sexualidade feminina; *Span.*: sexualidad femenina.

**femininity**

*Fr.*: féminité; *Ger.*: Weiblichkeit; *It.*: femminilità; *Port.*: feminidade; *Span.*: feminidad.

**femininity, rejection of**

*Fr.*: féminité (refus de la -); *Ger.*: Ablehnung der Weiblichkeit; *It.*: rifiuto della femminilità; *Port.*: recusa da feminidade; *Span.*: rechazo de la feminidad.

**fetishism**

*Fr.*: fétichisme; *Ger.*: Fetischismus; *It.*: feticismo; *Port.*: feiticismo; *Span.*: fetichismo.

**fixation**

*Fr.*: fixation; *Ger.*: Fixierung; *It.*: fissazione; *Port.*: fixação; *Span.*: fijación.

**flight into illness**

*Fr.*: fuite dans la maladie; *Ger.*: Flucht in die Krankheit; *It.*: fuga nella malattia; *Port.*: fuga na doença; *Span.*: huida en la enfermedad.

**foreclosure**

*Fr.*: forclusion; *Ger.*: Verwerfung; *It.*: preclusione; *Port.*: forclusão; *Span.*: repudio.

**forgetting**

*Fr.*: oubli; *Ger.*: Vergessen; *It.*: oblio; *Port.*: esquecimento; *Span.*: olvido.

**formula of fantasy**

*Fr.*: fantasme (formule du -); *Ger.*: Formel der Phantasie; *It.*: formula del fantasma; *Port.*: fórmula da fantasia; *Span.*: fórmula del fantasma.

**formations of the unconscious**

*Fr.*: formations de l'inconscient; *Ger.*: Bildungen des Unbewussten; *It.*: formazioni dell'inconscio; *Port.*: formações do inconsciente; *Span.*: formaciones del inconsciente.

**four discourses**

*Fr.*: discours (quatre -); *Ger.*: vier Diskurse; *It.*: quattro discorsi; *Port.*: quatro discursos; *Span.*: cuatro discursos.

**framework of the psychoanalytic treatment**

*Fr.*: cadre (de la cure psychanalytique); *Ger.*: Rahmen; *It.*: setting; *Port.*: enquadramento/Setting; *Span.*: encuadre.

**free energy/bound energy**

*Fr.*: énergie libre-énergie liée; *Ger.*: freie Energie-gebundene Energie; *It.*: energia libera-energia legata; *Port.*: energia livre-energia ligada; *Span.*: energía libre-energía ligada.

**fragmentation**

*Fr.*: fragmentation; *Ger.*: Zerkleinerung; *It.*: frammentazione; *Port.*: fragmentação; *Span.*: fragmentación.

**free association**

*Fr.*: association (méthode de libre -); *Ger.*: Methode der freien Assoziation; *It.*: associazione libera; *Port.*: método de associação livre; *Span.*: método de libre asociación.

**friendship**

*Fr.*: amitié; *Ger.*: Freundschaft; *It.*: amicizia; *Port.*: amizade; *Span.*: amistad.

**fright**

*Fr.*: effroi; *Ger.*: Schreck; *Span.*: susto; *It.*: spavento; *Port.*: susto, pavor.

**frustration**

*Fr.*: frustration; *Ger.*: Versagung; *It.*: frustrazione; *Port.*: frustração; *Span.*: frustración.

**fusion/defusion**

*Fr.*: fusion/défusion; *Ger.*: Verschmelzung/Entschmelzung; *It.*: impasto/disimpasto; *Port.*: fusão/defusão.-  
*Span.*: fusión/defusión.

**functional phenomenon**

*Fr.*: phénomène fonctionnel; *Ger.*: funktionales Phänomen; *It.*: fenomeno funzionale; *Port.*: fenômeno funcional; *Span.*: fenómeno funcional.

**fundamental rule**

*Fr.*: règle fondamentale; *Ger.*: Grundregel; *It.*: regola fondamentale; *Port.*: regra fundamental; *Span.*: regla fundamental.

**fusion/defusion of instincts**

*Fr.*: union-désunion des pulsions; *Ger.*: Triebmischung-Triebentmischung; *It.*: impasto-disimpasto delle pulsioni; *Port.*: fusão-desfusão das pulsões; *Span.*: fusión-defusión (pulsional).

**gain (primary and secondary)**

*Fr.*: bénéfice (primaire et secondaire); *Ger.*: Gewinn (primärer und sekundärer); *It.*: vantaggio (primario e secondario); *Port.*: benefício (primário e secundário); *Span.*: beneficio (primario y secundario).

**gender identity**

*Fr.*: identité sexuelle; *Ger.*: Geschlechtsidentität; *It.*: identità sessuale di genere; *Port.*: identidade sexual; *Span.*: identidad de género, identidad sexual.

**general theory of seduction**

*Fr.*: séduction généralisée (théorie de la -); *Ger.*: Theorie der allgemeinen Verführung; *It.*: teoria della seduzione generalizzata; *Port.*: teoria da sedução; *Span.*: teoría de la seducción.

**genital love**

*Fr.*: amour génital; *Ger.*: genitale Liebe; *It.*: amore genitale; *Port.*: amor genital; *Span.*: amor genital.

**genital stage**

*Fr.*: stade génital; *Ger.*: genitale Phase; *It.*: fase genitale; *Port.*: fase genital. *Span.*: fase genital.

**gift**

*Fr.*: cadeau; *Ger.*: Geschenk; *It.*: regalo; *Port.*: presente; *Span.*: regalo.

**good-enough mother**

*Fr.*: mère suffisamment bonne; *Ger.*: ausreichend gute Mutter; *It.*: madre sufficientemente buona; *Port.*: mãe

suficientemente boa; *Span.*: madre suficientemente buena.

#### **grandiose self**

*Fr.*: Soi grandiose; *Ger.*: Grössen-Selbst; *It.*: Sé grandioso; *Port.*: self grandioso; *Span.*: self grandioso.

#### **graph of desire**

*Fr.*: graphe du désir; *Ger.*: Graph des Begehrens; *It.*: grafo del desiderio; *Port.*: grafo do desejo; *Span.*: grafo del deseo.

#### **grid**

*Fr.*: grille; *Ger.*: Raster; *It.*: griglia; *Port.*: grelha; *Span.*: tabla.

#### **group analysis**

*Fr.*: groupe (analyse de - ou groupanalyse); *Ger.*: Gruppenanalyse; *It.*: analisi di gruppo/ gruppoanalisi; *Port.*: análise de grupo; *Span.*: análisis de grupo.

#### **group psychotherapy**

*Fr.*: groupe (psychothérapies de -); *Ger.*: Gruppenpsychotherapie; *It.*: psicoterapia di gruppo; *Port.*: psicoterapia de grupo; *Span.*: psicoterapias de grupo.

#### **guilt, feelings of**

*Fr.*: culpabilité (sentiment de -); *Ger.*: Schuldgefühl; *It.*: senso di colpa; *Port.*: sentimento de culpa; *Span.*: sentimiento de culpabilidad.

#### **guilt, unconscious sense of**

*Fr.*: culpabilité inconsciente (sentiment de -); *Ger.*: unbewusstes Schuldgefühl; *It.*: senso di colpa inconscio; *Port.*: culpa inconsciente; *Span.*: culpa inconsciente.

#### **hallucinatory, the**

*Fr.*: hallucinatoire (l'-); *Ger.*: das Halluzinatorische; *It.*: l'allucinatorio; *Port.*: o alucinatório; *Span.*: el/lo alucinatorio.

#### **hatred**

*Fr.*: haine; *Ger.*: Hass; *It.*: odio; *Port.*: ódio; *Span.*: odio.

#### **helplessness**

*Fr.*: détresse (état de -); *Ger.*: Hilflosigkeit; *It.*: impotenza, derelizione; *Port.*: desamparo; *Span.*: desamparo.

#### **hermeneutics**

*Fr.*: herméneutique; *Ger.*: Hermeneutik; *It.*: ermeneutica; *Port.*: hermenêutica; *Span.*: hermenéutica.

#### **heroic identification**

*Fr.*: identification héroïque; *Ger.*: heroische Identifizierung; *It.*: identificazione eroica; *Port.*: identificação heróica; *Span.*: identificación heroica.

#### **heterosexuality**

*Fr.*: hétérosexualité; *Ger.*: Heterosexualität; *It.*: eterosessualità; *Port.*: heterossexualidade; *Span.*: heterosexualidad.

#### **historical reality**

*Fr.*: réalité historique; *Ger.*: historische Realität; *It.*: realtà storica; *Port.*: realidade histórica; *Span.*: realidad histórica.

#### **historical truth**

*Fr.*: vérité historique; *Ger.*: historische Wahrheit; *It.*: verità storica; *Port.*: verdade histórica; *Span.*: verdad histórica.

#### **homosexuality**

*Fr.*: homosexualité; *Ger.*: Homosexualität; *It.*: omosessualità; *Port.*: homossexualidade; *Span.*: homosexualidad.

#### **hospitalism**

*Fr.*: hospitalisme; *Ger.*: Hospitalismus; *It.*: ospedalismo; *Port.*: hospitalismo; *Span.*: hospitalismo.

#### **humor**

*Fr.*: humour; *Ger.*: Humor; *It.*: umorismo; *Port.*: humor; *Span.*: humor.

#### **hypercathexis**

*Fr.*: surinvestissement; *Ger.*: Überbesetzung; *It.*: sovrainvestimento; *Port.*: sobrecarga/superinvestimento; *Span.*: sobrecarga.

#### **hypnoid states**

*Fr.*: hypnoïdes (états -); *Ger.*: hypnoide Zustände; *It.*: stati ipnoidi; *Port.*: estados hipnoïdes; *Span.*: estados hipnoïdes.

#### **hypnosis**

*Fr.*: hypnose; *Ger.*: Hypnose; *It.*: ipnosi; *Port.*: hipnose. *Span.*: hipnosis.

#### **hypochondria**

*Fr.*: hypocondrie; *Ger.*: Hypochondrie; *It.*: ipocondria; *Port.*: hipocondria; *Span.*: hipocondría.

#### **hypocritical dream**

*Fr.*: rêve hypocrite; *Ger.*: heuchlerischer Traum; *It.*: sogno ipocrita; *Port.*: sonho hipócrita; *Span.*: sueño hipócrita.

#### **hysteria**

*Fr.*: hystérie; *Ger.*: Hysterie; *It.*: isteria; *Port.*: histeria; *Span.*: histeria/histerismo.

#### **hysterical paralyses**

*Fr.*: paralysies hystériques; *Ger.*: hysterische Paralysien; *It.*: paralisi isteriche; *Port.*: paralisias históricas; *Span.*: parálisis históricas.

**I**

*Fr.:* Je; *Ger.:* Ich; *It.:* Io; *Port.:* Eu; *Span.:* Yo.

**Id**

*Fr.:* Ça; *Ger.:* Es; *It.:* Es; *Port.:* Isso; *Span.:* Ello.

**ideal ego**

*Fr.:* Moi idéal; *Ger.:* Idealich; *It.:* Io ideale; *Port.:* Eu-ideal; *Span.:* Yo ideal.

**idealization**

*Fr.:* idéalisation; *Ger.:* Idealisierung; *It.:* idealizzazione; *Port.:* idealização; *Span.:* idealización.

**idealized parental imago**

*Fr.:* imago parentale idéalisée; *Ger.:* idealisierte Elternimago; *It.:* imago parentale idealizzata; *Port.:* imago parental idealizada; *Span.:* imago parental idealizada.

**idealizing transference**

*Fr.:* transfert idéalisant; *Ger.:* idealisierende Übertragung; *It.:* transfert idealizzante; *Port.:* transferência idealizante; *Span.:* transferencia idealizante.

**ideational representative**

*Fr.:* représentant-représentation; *Ger.:* Vorstellungsrepräsentanz (Vorstellungsrepräsentant); *Span.:* representante-representativo; *It.:* rappresentante-rappresentazione (rappresentante ideativo); *Port.:* representante ideativo.

**identification**

*Fr.:* identification; *Ger.:* Identifizierung; *It.:* identificazione; *Port.:* identificação; *Span.:* identificación.

**identification fantasies**

*Fr.:* identification (fantasmes d’-); *Ger.:* Identifizierung-sphantasien; *It.:* fantasmi d’identificazione; *Port.:* fantasias de identificação; *Span.:* fantasmas de identificación.

**identification with the aggressor**

*Fr.:* identification à l’agresseur; *Ger.:* Identifizierung mit dem Angreifer; *It.:* identificazione con l’aggressore; *Port.:* identificação com o agressor; *Span.:* identificación con el agresor.

**identificatory project**

*Fr.:* projet identificatoire; *Ger.:* identifikatorisches Projekt; *It.:* progetto identificatorio; *Port.:* projecto identificatório; *Span.:* proyecto identificatorio.

**identity**

*Fr.:* identité; *Ger.:* Identität; *It.:* identità; *Port.:* identidade; *Span.:* identidad.

**ideology**

*Fr.:* idéologie; *Ger.:* Ideologie; *It.:* ideologia; *Port.:* ideologia; *Span.:* ideología.

**illusion**

*Fr.:* illusion; *Ger.:* Illusion; *It.:* illusione; *Port.:* ilusão; *Span.:* ilusión.

**the Imaginary**

*Fr.:* Imaginaire (l’); *Ger.:* das Imaginäre; *It.:* l’Immaginario; *Port.:* o Imaginário; *Span.:* lo Imaginario.

**imposter**

*Fr.:* imposteur; *Ger.:* Hochstapler; *It.:* impostore; *Port.:* impostor; *Span.:* impostor.

**incompleteness**

*Fr.:* inachèvement; *Ger.:* Unvollständigkeit; *It.:* incompletezza; *Port.:* incompletude; *Span.:* incompletud.

**incest**

*Fr.:* inceste; *Ger.:* Inzest; *It.:* incesto; *Port.:* incesto; *Span.:* incesto.

**individual**

*Fr.:* individu; *Ger.:* Individuum; *It.:* individuo; *Port.:* indivíduo; *Span.:* individuo.

**infant development**

*Fr.:* nourrisson (développement du -); *Ger.:* Entwicklung des Säuglings; *It.:* sviluppo del neonatto; *Port.:* desenvolvimento do bebé; *Span.:* desarrollo del lactante.

**infant observation**

*Fr.:* bébé (observation du -); *Ger.:* Säuglingsbeobachtung; *It.:* osservazione del bambino; *Port.:* observação de bebés; *Span.:* observación de bebés.

**infantile amnesia**

*Fr.:* amnésie infantile; *Ger.:* frühkindliche/infantile Amnesie; *It.:* amnesia infantile; *Port.:* amnésia infantil; *Span.:* amnesia infantil.

**infantile neurosis**

*Fr.:* névrose infantile; *Ger.:* infantile Neurose; *It.:* nevrosi infantile; *Port.:* neurose infantil; *Span.:* neurosis infantil.

**infantile omnipotence**

*Fr.:* toute-puissance (omnipotence); *Ger.:* Allmacht, Omnipotenz; *It.:* onnipotenza; *Port.:* onnipotência; *Span.:* omnipotencia.

**infantile psychosis**

*Fr.:* psychose infantile; *Ger.:* infantile Psychose; *It.:* psicosi infantile; *Port.:* psicose infantil; *Span.:* psicosis infantil.

**infantile schizophrenia**

*Fr.*: schizophrénie infantile; *Ger.*: infantile Schizophrenie; *It.*: schizofrenia infantile; *Port.*: esquizofrenia infantil; *Span.*: esquizofrenia infantil.

**infantile sexual curiosity**

*Fr.*: curiosité sexuelle infantile; *Ger.*: infantile Sexualneugier; *It.*: curiosità sessuale infantile; *Port.*: curiosidade sexual infantil; *Span.*: curiosidad sexual infantil.

**inferiority, feeling of**

*Fr.*: sentiment d'infériorité; *Ger.*: Minderwertigkeitsgefühl; *It.*: senso d'inferiorità; *Port.*: sentimento de inferioridade; *Span.*: sentimiento de inferioridad.

**inhibition**

*Fr.*: inhibition; *Ger.*: Hemmung; *It.*: inibizione; *Port.*: inibição; *Span.*: inhibición.

**initial interview(s)**

*Fr.*: entretien(s) préliminaire(s); *Ger.*: Erstinterview; *It.*: colloqui preliminari; *Port.*: entrevistas preliminares; *Span.*: entrevista(s) preliminare(s).

**innervation**

*Fr.*: innervation; *Ger.*: Innervation; *It.*: innervazione; *Port.*: inervação; *Span.*: inervación.

**instinct**

*Fr.*: instinct; *Ger.*: Instinkt; *It.*: istinto; *Port.*: instinto; *Span.*: instinto.

**instinct/drive**

*Fr.*: pulsion; *Ger.*: Trieb/Instinkt; *It.*: pulsione; *Port.*: pulsão; *Span.*: pulsión.

**instinct for mastery**

*Fr.*: emprise (pulsion d'-); *Ger.*: Bemächtigungstrieb; *It.*: pulsione d'impossessamento; *Port.*: pulsão de dominação; *Span.*: pulsión de dominio.

**instinctual impulse**

*Fr.*: motion pulsionnelle; *Ger.*: Triebregung; *It.*: moto pulsionale; *Port.*: moção pulsional; *Span.*: moción pulsional.

**instinctual representative**

*Fr.*: représentant pulsionnel (représentant de la pulsion); *Ger.*: Triebrepräsenz (Triebrepräsident); *It.*: rappresentante pulsionale (rappresentante della pulsione); *Port.*: representante pulsional (representante da pulsão); *Span.*: representante pulsional (representante de la pulsión).

**integration**

*Fr.*: intégration; *Ger.*: Integration; *It.*: integrazione; *Port.*: integração; *Span.*: integración.

**intellectualization**

*Fr.*: intellectualisation; *Ger.*: Intellektualisierung; *It.*: intellettualizzazione; *Port.*: intelectualização; *Span.*: intelectualización.

**intergenerational**

*Fr.*: transgénérationnel (intergénérationnel); *Ger.*: generationsüberschreitend/transgenerationell/intergenerationell; *It.*: transgenerazionale/intergenerazionale; *Port.*: transgeracional/intergeracional; *Span.*: transgeneracional/intergeneracional.

**internal/external reality**

*Fr.*: réalité intérieure/réalité extérieure; *Ger.*: innere Realität/äussere Realität; *It.*: realtà interna/realtà esterna; *Port.*: realidade interna/realidade externa; *Span.*: realidad interior/ realidad exterior.

**internal object**

*Fr.*: objet interne; *Ger.*: inneres Objekt; *It.*: oggetto interno; *Port.*: objecto interno; *Span.*: objeto interno.

**interpretation**

*Fr.*: interprétation; *Ger.*: Deutung; *It.*: interpretazione; *Port.*: interpretação; *Span.*: interpretación.

**intersubjective/intrasubjective**

*Fr.*: intersubjectif/intrasubjectif; *Ger.*: intersubjektiv/intrasubjektiv; *It.*: intersoggettivo/intrasoggettivo; *Port.*: intersubjetivo/intrasubjetivo; *Span.*: intersubjetivo/ intrasubjetivo.

**introjection**

*Fr.*: introjection; *Ger.*: Introjektion; *It.*: introiezione; *Port.*: introjeção; *Span.*: introyección.

**introspection**

*Fr.*: introspection; *Ger.*: Selbstbeobachtung; *It.*: introspezione; *Port.*: introspeção; *Span.*: introspección.

**isolation**

*Fr.*: isolation; *Ger.*: Isolierung; *It.*: isolamento; *Port.*: isolamento; *Span.*: aislamiento.

**joke**

*Fr.*: mot d'esprit; *Ger.*: Witz; *It.*: motto di spirito; *Port.*: piada/chiste; *Span.*: chiste.

**jouissance**

*Fr.*: jouissance; *Ger.*: Geniessen; *It.*: godimento; *Port.*: gozo; *Span.*: goce.

**judgment of condemnation**

*Fr.*: jugement de condamnation; *Ger.*: Urteilsverwerfung; *It.*: giudizio di condanna; *Port.*: julgamento de condenação; *Span.*: juicio de condenación.

**knot**

*Fr.*: nœud; *Ger.*: Knoten; *It.*: nodo; *Port.*: nó; *Span.*: nudo.

**knowledge or research, instinct for**

*Fr.*: recherche (pulsion de -); *Ger.*: Wiss-/Forschertrieb; *It.*: pulsione di conoscere, pulsione di sapere; *Port.*: pulsão de investigação; *Span.*: pulsión de investigación (epistemofilia).

**L and R schemas**

*Fr.*: schémas L et R; *Ger.*: Modelle L und R; *It.*: schemi L e R; *Port.*: esquemas L e R; *Span.*: esquemas L y R.

**lack of differentiation**

*Fr.*: indifférenciation; *Ger.*: Undifferenziertheit; *It.*: indifferenziazione; *Port.*: indiferenciação; *Span.*: indiferenciación.

**language and disturbances of language**

*Fr.*: langage et troubles du langage; *Ger.*: Sprache und Sprachstörungen; *It.*: linguaggio e disturbi del linguaggio; *Port.*: linguagem e perturbações da linguagem; *Span.*: lenguaje y trastornos del lenguaje.

**latency period**

*Fr.*: latence (période de -); *Ger.*: Latenzperiode/Latenzzeit; *It.*: periodo di latenza; *Port.*: período de latência; *Span.*: período de latencia.

**latent**

*Fr.*: latent; *Ger.*: latent; *It.*: latente; *Port.*: latente; *Span.*: latente.

**latent dream thoughts**

*Fr.*: rêve (pensées latentes du -); *Ger.*: latente Traumgedanken; *It.*: pensieri latenti del sogno; *Port.*: pensamentos latentes do sonho; *Span.*: pensamientos latentes del sueño.

**Law of the Father**

*Fr.*: Loi du Père; *Ger.*: Vaterrecht; *It.*: Legge del Padre; *Port.*: Lei do Pai; *Span.*: Ley del Padre.

**lay analysis**

*Fr.*: analyse profane (ou laïque); *Ger.*: Laienanalyse; *It.*: analisi profana; *Port.*: análise laica; *Span.*: análisis profano.

**letter, the**

*Fr.*: lettre (la -); *Ger.*: Buchstabe; *It.*: lettera; *Port.*: letra; *Span.*: letra.

**libidinal development**

*Fr.*: développement libidinal; *Ger.*: Libidoentwicklung; *It.*: sviluppo libidico; *Port.*: desenvolvimento libidinal; *Span.*: desarrollo libidinal.

**libidinal stage**

*Fr.*: stade libidinal; *Ger.*: Libidophase; *It.*: fase libidica; *Port.*: fase libidinal; *Span.*: fase libidinal.

**lie**

*Fr.*: mensonge; *Ger.*: Lüge; *It.*: bugia; *Port.*: mentira; *Span.*: mentira.

**life instinct**

*Fr.*: pulsion de vie; *Ger.*: Lebenstrieb; *It.*: pulsione di vita; *Port.*: pulsão de vida; *Span.*: pulsión de vida.

**listening**

*Fr.*: écoute; *Ger.*: Zuhören; *It.*: ascolto; *Port.*: escuta; *Span.*: escucha.

**lifting of amnesia**

*Fr.*: amnésie (levée de l'-); *Ger.*: Aufheben einer Amnesie; *It.*: superamento della amnesia; *Port.*: levantamento da amnésia; *Span.*: levantamiento de la amnesia.

**linking, attacks on**

*Fr.*: liens (attaques des -); *Ger.*: Angriffe auf Bindungen; *It.*: attacchi al legame; *Port.*: ataque contra o vínculo; *Span.*: ataque al vínculo.

**look/gaze**

*Fr.*: regard; *Ger.*: Blick; *It.*: sguardo; *Port.*: olhar; *Span.*: mirada.

**lost object**

*Fr.*: objet (perte d'-), objet perdu; *Ger.*: Objektverlust, das verlorene Objekt; *It.*: perdita d'oggetto/oggetto perduto; *Port.*: perda do objecto, objecto perdido; *Span.*: pérdida de objeto, objeto perdido.

**love**

*Fr.*: amour; *Ger.*: Liebe; *It.*: amore; *Port.*: amor; *Span.*: amor.

**Love-Hate-Knowledge**

*Fr.*: Amour-Haine-Connaissance; *Ger.*: Liebe-Hass-Wissen; *It.*: Amore-Odio-Conoscenza; *Port.*: Amor-Odio-Conhecimento; *Span.*: Amor-Odio-Conocimiento.

**magical thought**

*Fr.*: magique (pensée -); *Ger.*: magisches Denken; *It.*: pensiero magico; *Port.*: pensamento mágico; *Span.*: pensamiento mágico.

**mania**

*Fr.*: manie; *Ger.*: Manie; *It.*: mania; *Port.*: mania; *Span.*: manía.

**manic defenses**

*Fr.*: défenses maniaques; *Ger.*: manische Abwehr(mechanismen); *It.*: difese maniacali; *Port.*: defesas maníacas; *Span.*: defensas maníacas.

**manifest**

*Fr.*: manifeste; *Ger.*: manifest; *It.*: manifesto; *Port.*: manifesto; *Span.*: manifiesto.

**mastery**

*Fr.*: maîtrise; *Ger.*: Bewältigung/Beherrschung; *It.*: padronanza; *Port.*: domínio; *Span.*: dominio.

**masculinity/femininity**

*Fr.*: masculinité/féminité; *Ger.*: Männlichkeit/Weiblichkeit; *It.*: mascolinità/femminilità; *Port.*: masculinidade/feminidade; *Span.*: masculinidad/feminidad.

**masochism**

*Fr.*: masochisme; *Ger.*: Masochismus; *It.*: masochismo; *Port.*: masoquismo; *Span.*: masoquismo.

**masturbation**

*Fr.*: masturbation; *Ger.*: Onanie; *It.*: masturbazione; *Port.*: masturbação; *Span.*: masturbación.

**maternal**

*Fr.*: maternel; *Ger.*: mütterlich; *It.*: materno; *Port.*: maternal; *Span.*: maternal.

**maternal care**

*Fr.*: soins maternels; *Ger.*: mütterliche Fürsorge; *It.*: cure materne; *Port.*: cuidados maternos; *Span.*: cuidados maternos.

**matheme**

*Fr.*: mathème; *Ger.*: Mathema; *It.*: matema; *Port.*: matema; *Span.*: matema.

**maturation**

*Fr.*: maturation; *Ger.*: Reifung; *It.*: maturazione; *Port.*: maturação; *Span.*: maduración.

**megalomania**

*Fr.*: mégalomanie; *Ger.*: Grössenwahn; *It.*: megalomania; *Port.*: megalomania; *Span.*: megalomanía.

**melancholia**

*Fr.*: mélancolie; *Ger.*: Melancholie; *It.*: melanconia; *Port.*: melancolia; *Span.*: melancolía.

**melancholic depression**

*Fr.*: dépression mélancolique; *Ger.*: melancholische Depression; *It.*: depressione melanconica; *Port.*: depressão melancólica; *Span.*: depresión melancólica.

**memoirs of the future**

*Fr.*: souvenirs du futur; *Ger.*: Erinnerungen an die Zukunft; *It.*: ricordi del futuro; *Port.*: lembranças do futuro; *Span.*: recuerdos del futuro.

**memories**

*Fr.*: souvenir; *Ger.*: Erinnerung; *It.*: ricordo; *Port.*: recordação; *Span.*: recuerdo.

**memory**

*Fr.*: mémoire; *Ger.*: Gedächtnis; *It.*: memoria; *Port.*: memória; *Span.*: memoria.

**mentalisation**

*Fr.*: mentalisation; *Ger.*: Mentalisierung; *It.*: mentalizzazione; *Port.*: mentalização; *Span.*: mentalización.

**metaphor**

*Fr.*: métaphore; *Ger.*: Metapher; *It.*: metafora; *Port.*: metáfora; *Span.*: metáfora.

**metapsychology**

*Fr.*: métapsychologie; *Ger.*: Metapsychologie; *It.*: metapsicologia; *Port.*: metapsicologia; *Span.*: metapsicología.

**metonymy**

*Fr.*: métonymie; *Ger.*: Metonymie; *It.*: metonimia; *Port.*: metonímia; *Span.*: metonimia.

**midlife crisis**

*Fr.*: maturité (crise de la -); *Ger.*: Maturitätskrise; *It.*: crisi della maturità; *Port.*: crise de maturidade; *Span.*: crisis de la madurez.

**mirror stage**

*Fr.*: stade du miroir; *Ger.*: Spiegelstadium; *It.*: stadio dello specchio; *Port.*: estádio do espelho; *Span.*: estadio del espejo.

**mirror transference**

*Fr.*: transfert en miroir; *Ger.*: Spiegelübertragung; *It.*: transferencia especular; *Port.*: transferência especular; *Span.*: transferencia especular.

**mnemonic symbol**

*Fr.*: symbole mnésique; *Ger.*: Erinnerungssymbol; *It.*: simbolo mnestico; *Port.*: símbolo mnésico; *Span.*: símbolo mnémico.

**mnemonic trace, memory trace**

*Fr.*: trace mnésique; *Ger.*: Erinnerungsspur; *It.*: traccia mnestica; *Port.*: traço mnésico; *Span.*: huella mnémica.

**model**

*Fr.*: modèle; *Ger.*: Modell; *It.*: modello; *Port.*: modelo; *Span.*: modelo.

**modesty**

*Fr.*: pudeur; *Ger.*: Scham (-haftigkeit); *It.*: pudore; *Port.*: pudor; *Span.*: pudor.

**monism**

*Fr.*: monisme; *Ger.*: Monismus; *It.*: monismo; *Port.*: monismo; *Span.*: monismo.

**moral masochism**

*Fr.*: masochisme moral; *Ger.*: moralischer Masochismus; *It.*: masochismo morale; *Port.*: masoquismo moral; *Span.*: masoquismo moral.

**Mother Goddess**

*Fr.*: déesse-mère; *Ger.*: Mutter Göttin; *It.*: Dea Madre; *Port.*: Deusa-mãe; *Span.*: Diosa-madre.

**motricity/psychomotricity**

*Fr.*: motricité, psychomotricité; *Ger.*: Motorik, Psychomotorik; *It.*: motricità, psicomotricità; *Port.*: motricidade, psicomotricidade; *Span.*: motricidad, psicomotricidad.

**mourning**

*Fr.*: rêve de deuil; *Ger.*: Trauertraum; *It.*: sogno di lutto; *Port.*: sonho de luto; *Span.*: sueño de duelo.

**mutative interpretation**

*Fr.*: interprétation mutative; *Ger.*: verändernde Deutung; *It.*: interpretazione mutativa; *Port.*: interpretação mutativa; *Span.*: interpretación mutativa.

**mutual analysis**

*Fr.*: analyse mutuelle; *Ger.*: mutuelle Analyse; *It.*: analisi reciproca; *Port.*: análise mútua; *Span.*: análisis mutuo.

**mysticism**

*Fr.*: mysticisme; *Ger.*: Mystik/Mystizismus; *It.*: misticismo; *Port.*: misticismo; *Span.*: misticismo.

**myth**

*Fr.*: mythe; *Ger.*: Mythus/Mythos; *It.*: mito; *Port.*: mito; *Span.*: mito.

**myth of origins**

*Fr.*: mythe des origines; *Ger.*: Ursprungsmythus; *It.*: mito delle origini; *Port.*: mito das origens; *Span.*: mito de los orígenes.

**myth of the hero**

*Fr.*: héros (mythe du -); *Ger.*: Mythus des Helden; *It.*: mito dell'eroe; *Port.*: mito do herói; *Span.*: mito del héroe.

**mythomania**

*Fr.*: mythomanie; *Ger.*: Mythomanie; *It.*: mitomania; *Port.*: mitomania; *Span.*: mitomanía.

**nakedness, dream of**

*Fr.*: rêve de nudité; *Ger.*: Nacktheitstraum; *It.*: sogno di nudità; *Port.*: sonho de nudez; *Span.*: sueño de desnudez.

**Name-of-the-Father**

*Fr.*: Nom-du-Père; *Ger.*: Name-des-Vaters; *It.*: Nome del Padre; *Port.*: Nome do Pai; *Span.*: Nombre del Padre.

**narcissism**

*Fr.*: narcissisme; *Ger.*: Narzissmus; *It.*: narcisismo; *Port.*: narcisismo; *Span.*: narcisismo.

**narcissism of minor differences**

*Fr.*: narcissisme des petites différences; *Ger.*: Narzissmus der kleinen Unterschiede; *It.*: narcisismo delle piccole differenze; *Port.*: narcisismo das pequenas diferenças; *Span.*: narcisismo de las pequeñas diferencias.

**narcissistic defenses**

*Fr.*: défenses narcissiques; *Ger.*: narzisstische Abwehr(mechanismen); *It.*: difese narcisistiche; *Port.*: defesas narcísicas; *Span.*: defensas narcisísticas.

**narcissistic elation**

*Fr.*: élation narcissique; *Ger.*: narzisstische Gehobenheit; *It.*: elazione narcisistica; *Port.*: elação narcísica; *Span.*: elación narcisística.

**narcissistic injury**

*Fr.*: blessure narcissique; *Ger.*: narzisstische Kränkung; *It.*: ferita narcisistica; *Port.*: ferida narcísica; *Span.*: herida narcisista.

**narcissistic neurosis**

*Fr.*: névrose narcissique; *Ger.*: narzisstische Neurose; *It.*: nevrosi narcisistica; *Port.*: neurose narcísica; *Span.*: neurosis narcisista.

**narcissistic rage**

*Fr.*: rage narcissique; *Ger.*: narzisstische Wut; *It.*: rabbia narcisistica; *Port.*: raiva narcísica; *Span.*: furia narcisista.

**narcissistic transference**

*Fr.*: transfert narcissique; *Ger.*: narzisstische Übertragung; *It.*: transfert narcisistico; *Port.*: transferência narcísica; *Span.*: transferencia narcisista.

**narcissistic withdrawal**

*Fr.*: narcissique (repli -); *Ger.*: narzisstischer Rückzug; *It.*: ritiro narcisistico; *Port.*: retraimento narcísico; *Span.*: repliegue narcisista.

**narco-analysis**

*Fr.*: narco-analyse; *Ger.*: Narkose-Analyse; *It.*: narcoanalisi; *Port.*: narcoanálise; *Span.*: narcoanálisis.

**negative hallucination**

*Fr.*: hallucination négative; *Ger.*: negative Halluzination; *It.*: allucinazione negativa; *Port.*: alucinação negativa; *Span.*: alucinación negativa.

**negative, work of the**

*Fr.*: négatif (travail du -); *Ger.*: Arbeit des Negativen; *It.*: lavoro del negativo; *Port.*: trabalho do negativo; *Span.*: trabajo del negativo.

**negation**

*Fr.*: négation; *Ger.*: Verneinung; *It.*: negazione; *Port.*: negação; *Span.*: negación.



**need for causality**

*Fr.*: besoin de causalité; *Ger.*: Kausalitätsbedürfnis; *It.*: bisogno di causalità; *Port.*: necessidade de causalidade; *Span.*: necesidad de causalidad.

**need for punishment**

*Fr.*: besoin de punition; *Ger.*: Strafbedürfnis; *It.*: bisogno di punizione; *Port.*: necessidade de punição; *Span.*: necesidad de castigo.

**negative capability**

*Fr.*: capacité négative; *Ger.*: Fähigkeit zur Negativität; *It.*: capacità negativa; *Port.*: capacidade negativa; *Span.*: capacidad negativa.

**negative therapeutic reaction**

*Fr.*: réaction thérapeutique négative; *Ger.*: negative therapeutische Reaktion; *It.*: reazione terapeutica negativa; *Port.*: reação terapêutica negativa; *Span.*: reacción terapéutica negativa.

**negative transference**

*Fr.*: transfert négatif; *Ger.*: negative Übertragung; *Span.*: transferencia negativa; *It.*: transfert negativo; *Port.*: transferência negativa.

**neurasthenia**

*Fr.*: neurasthénie; *Ger.*: Neurasthenie; *It.*: nevrastenia; *Port.*: neurastenia; *Span.*: neurastenia.

**neuro-psychosis of defense**

*Fr.*: psychonévrose de défense; *Ger.*: Abwehr-Neuropsychose; *It.*: psiconevrosi da difesa; *Port.*: psiconeurose de defesa; *Span.*: psiconeurosis de defensa.

**neuroses**

*Fr.*: névroses; *Ger.*: Neurosen; *It.*: nevrosi; *Port.*: neuroses; *Span.*: neurosis.

**neurotic defenses**

*Fr.*: défenses névrotiques; *Ger.*: neurotische Abwehr(-mechanismen); *It.*: difese nevrotiche; *Port.*: defesas neuróticas; *Span.*: defensas neuróticas.

**neutrality/benevolent neutrality**

*Fr.*: neutralité, neutralité bienveillante; *Ger.*: Neutralität, wohlwollende Neutralität; *It.*: neutralità, neutralità benevola; *Port.*: neutralidade, neutralidade benevolente; *Span.*: neutralidad, neutralidad amable.

**nightmare**

*Fr.*: cauchemar; *Ger.*: Alptraum; *It.*: incubo; *Port.*: pesadelo; *Span.*: pesadilla.

**night terror**

*Fr.*: terreur nocturne; *Ger.*: Pavor nocturnus; *It.*: pavor nocturnus; *Port.*: terror nocturno; *Span.*: terror nocturno.

**nonverbal communication**

*Fr.*: communication non verbale; *Ger.*: nonverbale Kommunikation; *It.*: comunicazione non verbale; *Port.*: comunicação não verbal; *Span.*: comunicación no verbal.

**normality**

*Fr.*: normalité; *Ger.*: Normalität; *It.*: normalità; *Port.*: normalidade; *Span.*: normalidad.

**nostalgia**

*Fr.*: nostalgie; *Ger.*: Nostalgie, Heimweh; *Span.*: nostalgia; *It.*: nostalgia; *Port.*: nostalgia.

**nuclear complex**

*Fr.*: complexe nucléaire; *Ger.*: Kernkomplex; *It.*: complesso nucleare; *Port.*: complexo nuclear; *Span.*: complejo nuclear.

**numinous**

*Fr.*: numineux; *Ger.*: Numinose; *It.*: numinoso; *Port.*: numinoso; *Span.*: numinoso.

**object**

*Fr.*: objet; *Ger.*: Objekt; *It.*: oggetto; *Port.*: objecto; *Span.*: objeto.

**object a**

*Fr.*: objet a; *Ger.*: Objekt a; *It.*: oggetto a; *Port.*: objecto a; *Span.*: objeto a.

**object, change of/choice of**

*Fr.*: objet (changement d'-, choix d'-); *Ger.*: Objektwechsel, Objektwahl; *It.*: cambiamento d'oggetto, scelta d'oggetto; *Port.*: mudança de objecto, escolha de objecto; *Span.*: cambio de objeto, elección de objeto.

**object relations**

*Fr.*: relations d'objet; *Ger.*: Objektbeziehungen; *object relations* *Span.*: relaciones de objeto; *It.*: relazioni oggettuali; *Port.*: relações de objecto.

**obsessional neurosis**

*Fr.*: névrose obsessionnelle; *Ger.*: Zwangsneurose; *It.*: nevrosi ossessiva; *Port.*: neurose obsessiva; *Span.*: neurosis obsesiva.

**obsession**

*Fr.*: obsession; *Ger.*: Obsession, Zwangsvorstellung; *It.*: ossessione; *Port.*: obsessão; *Span.*: obsesión.

**oceanic feeling**

*Fr.*: sentiment océanique; *Ger.*: ozeanisches Gefühl; *Span.*: sentimiento oceánico; *It.*: sentimento oceanico; *Port.*: sentido oceânico.

**occultism**

*Fr.*: occultisme; *Ger.*: Geheimwissenschaft/Okkultismus; *It.*: occultismo; *Port.*: ocultismo; *Span.*: ocultismo.

**Oedipus complex**

*Fr.*: complexe d'Édipe; *Ger.*: Ödipuskomplex; *It.*: complesso di Edipo; *Port.*: complexo de Édipo; *Span.*: complejo de Edipo.

**omnipotence of thoughts**

*Fr.*: toute-puissance des pensées; *Ger.*: Allmacht der Gedanken, omnipotentes Denken; *It.*: onnipotenza del pensiero; *Port.*: onnipotência do pensamento; *Span.*: omnipotencia del pensamiento.

**ontogeny**

*Fr.*: ontogénèse; *Ger.*: Ontogenese; *It.*: ontogenesi; *Port.*: ontogênese; *Span.*: ontogénesis.

**operational thinking**

*Fr.*: pensée opératoire; *Ger.*: operatives Denken; *It.*: pensiero operatorio; *Port.*: pensamento operatório; *Span.*: pensamiento operatorio.

**optical schema**

*Fr.*: schéma optique; *Ger.*: optisches Modell/visuelles Modell; *It.*: schema ottico; *Port.*: esquema óptico; *Span.*: esquema óptico.

**oral eroticism**

*Fr.*: érotisme oral; *Ger.*: Oralerotik; *It.*: erotismo orale; *Port.*: erotismo oral; *Span.*: erotismo oral.

**orality**

*Fr.*: oralité; *Ger.*: Oralität; *It.*: oralità; *Port.*: oralidade; *Span.*: oralidad.

**oral-sadistic stage**

*Fr.*: stade sadique-oral (ou cannibalique); *Ger.*: oralsadistische Phase, kannibalistische Phase; *It.*: fase sadico-orale, fase cannibalica; *Port.*: fase oral-sádica, fase canibalística; *Span.*: fase sádico-oral (o canibalística).

**oral stage**

*Fr.*: stade oral; *Ger.*: orale Phase; *It.*: fase orale; *Port.*: fase oral; *Span.*: fase oral.

**organic psychoses**

*Fr.*: psychoses organiques; *Ger.*: organische Psychosen; *It.*: psicosi organiche; *Port.*: psicoses orgânicas; *Span.*: psicosis orgánicas.

**organic repression**

*Fr.*: refoulement organique; *Ger.*: organische Verdrängung; *It.*: rimozione organica; *Port.*: recalque orgânico; *Span.*: represión orgánica.

**organization**

*Fr.*: organisation; *Ger.*: Organisation; *It.*: organizzazione; *Port.*: organização; *Span.*: organización.

**organ pleasure**

*Fr.*: plaisir d'organe; *Ger.*: Organlust; *It.*: piacere d'organo; *Port.*: prazer de órgão; *Span.*: placer de órgano.

**orgasm**

*Fr.*: orgasme; *Ger.*: Orgasmus; *It.*: orgasmo; *Port.*: orgasmo; *Span.*: orgasmo.

**orgone**

*Fr.*: orgone; *Ger.*: Orgonenergie; *It.*: orgone; *Port.*: orgone; *Span.*: orgón.

**Other**

*Fr.*: Autre; *Ger.*: Anderer; *It.*: Altro; *Port.*: Outro; *Span.*: Otro.

**otherness/alterity**

*Fr.*: altérité; *Ger.*: Andersheit/Anderssein; *It.*: alterità; *Port.*: alteridade; *Span.*: alteridad.

**overdetermination**

*Fr.*: surdétermination; *Ger.*: Überdeterminierung; *It.*: sovradeterminazione; *Port.*: superdeterminação; *Span.*: sobredeterminación.

**over-interpretation**

*Fr.*: surinterprétation; *Ger.*: Überdeutung; *It.*: sovrainterpretazione; *Port.*: superinterpretação; *Span.*: sobreinterpretación.

**pair of opposites**

*Fr.*: couples d'opposés; *Ger.*: Gegensatzpaar; *It.*: coppia d'opposti; *Port.*: par antitético; *Span.*: par antitético.

**parade of the signifier**

*Fr.*: défilé du signifiant; *Ger.*: Engführung des Signifikanten; *It.*: défilé del significante; *Port.*: desfiladeiro do significante; *Span.*: desfiladero del significante.

**paradox**

*Fr.*: paradoxe; *Ger.*: Paradox; *It.*: paradosso; *Port.*: paradoxo; *Span.*: paradoja.

**paranoid position**

*Fr.*: position paranoïde; *Ger.*: paranoide Position; *It.*: posizione paranoide; *Port.*: posição paranóide; *Span.*: posición paranoide.

**paranoid psychosis**

*Fr.*: psychose paranoïde; *Ger.*: Paranoia; *It.*: psicosi paranoide; *Port.*: psicose paranóide; *Span.*: psicosis paranoide.

**parapraxis**

*Fr.*: acte manqué ; *Ger.*: Fehlleistung/Fehlhandlung *It.*: atto mancato; *Port.*: acto falhado/ato falho; *Span.*: acto fallido.

**paranoid-schizoid position**

*Fr.*: position schizo-paranoïde; *Ger.*: paranoïde-schizoïde Position; *It.*: posizione schizoparanoide; *Port.*: posição esquizo-paranoïde; *Span.*: posición esquizo-paranoïde.

**paraphrenia**

*Fr.*: paraphrénie; *Ger.*: Paraphrenie; *It.*: parafrenia; *Port.*: parafrenia; *Span.*: parafrenia.

**paranoid psychosis**

*Fr.*: psychose paranoïde; *Ger.*: Paranoia; *It.*: psicosi paranoïde; *Port.*: psicose paranoïde; *Span.*: psicosis paranoïde.

**parapraxis**

*Fr.*: acte manqué ; *Ger.*: Fehlleistung/Fehlhandlung *It.*: atto mancato; *Port.*: acto falhado/ato falho; *Span.*: acto fallido.

**parenthood**

*Fr.*: parentalité; *Ger.*: Elternschaft; *It.*: genitorialità; *Port.*: parentalidade; *Span.*: parentalidad.

**parricide**

*Fr.*: meurtre du père; *Ger.*: Vatemord; *It.*: uccisione del padre; *Port.*: assassinio do pai; *Span.*: asesinato del padre/parricidio.

**partial drive**

*Fr.*: pulsion partielle; *Ger.*: Partialtrieb; *It.*: pulsione parziale; *Port.*: pulsão parcial; *Span.*: pulsión parcial.

**passion**

*Fr.*: passion; *Ger.*: Leidenschaft; *It.*: passione; *Port.*: paixão; *Span.*: pasión.

**pass, the**

*Fr.*: passe (la -); *Ger.*: "Passe"; *It.*: la passe; *Port.*: o passe; *Span.*: el pase.

**penis envy**

*Fr.*: envie du pénis; *Ger.*: Penisneid; *It.*: invidia del pene; *Port.*: inveja do pénis; *Span.*: envidia del pene.

**Perception-Consciousness**

*Fr.*: Perception-Conscience; *Ger.*: Wahrnehmung-Bewusstsein; Perception-Consciousness *It.*: Percezione-Coscienza; *Port.*: Percepção-Consciência; *Span.*: Percepción-Conciencia.

**perceptual identity**

*Fr.*: identité de perception; *Ger.*: Wahrnehmungsidentität; *It.*: identità di percezione; *Port.*: identidade de percepção; *Span.*: identidad de percepción.

**persecution**

*Fr.*: persécution; *Ger.*: Verfolgung; *It.*: persecuzione; *Port.*: perseguição; *Span.*: persecución.

**perversion**

*Fr.*: perversion; *Ger.*: Perversion; *It.*: perversione; *Port.*: perversão; *Span.*: perversión.

**phallic woman**

*Fr.*: femme phallique; *Ger.*: phallische Frau; *It.*: donna fallica; *Port.*: mulher fálica; *Span.*: mujer fálica.

**phantom**

*Fr.*: fantôme; *Ger.*: Gespenst; *It.*: spettro; *Port.*: espectro; *Span.*: espectro.

**phallic mother**

*Fr.*: mère phallique; *Ger.*: phallische Mutter; *It.*: madre fallica; *Port.*: mãe fálica; *Span.*: madre fálica.

**phallic stage**

*Fr.*: stade phallique; *Ger.*: phallische Phase; *It.*: fase fallica; *Port.*: fase fálica; *Span.*: fase fálica.

**phobia**

*Fr.*: phobie; *Ger.*: Phobie; *It.*: fobia; *Port.*: fobia; *Span.*: fobia.

**phobia of committing impulsive acts**

*Fr.*: phobie d'impulsion; *Ger.*: Phobie mit Zwangsimpulsen; *It.*: fobia di impulso; *Port.*: fobia de impulsividade; *Span.*: fobia de impulso.

**phobic neurosis**

*Fr.*: névrose phobique; *Ger.*: phobische Neurose; *It.*: nevrosi fobica; *Port.*: neurose fóbica; *Span.*: neurosis fóbica.

**phylogenesis**

*Fr.*: phylogénèse; *Ger.*: Phylogenese; *It.*: filogenesi; *Port.*: filogênese; *Span.*: filogénesis.

**pictogram**

*Fr.*: pictogramme; *Ger.*: Piktogramm; *It.*: pittogramma; *Port.*: pictograma; *Span.*: pictograma.

**pleasure-ego/reality-ego**

*Fr.*: Moi-plaisir/Moi-réalité; *Ger.*: Lust-Ich/Realitäts-Ich; *It.*: Io-piacere/Io-realtà; *Port.*: Eu-prazer/Eu-realidade; *Span.*: Yo-placer/Yo-realidad.

**pleasure in thinking**

*Fr.*: plaisir de pensée; *Ger.*: Vergnügen am Denken; *It.*: piacere del pensiero; *Port.*: prazer de pensamento; *Span.*: placer de pensamiento.

**postnatal/postpartum depression**

*Fr.*: dépression postnatale ; *Ger.*: postpartale Depression; *It.*: depressione post-partum; *Port.*: depressão pós-parto; *Span.*: depresión postparto.

**preconception**

*Fr.*: préconception; *Ger.*: Präkonzeption; *It.*: preconcezione; *Port.*: pré-concepção; *Span.*: pre-concepción.

**Preconscious, the**

*Fr.*: Préconscient (le -); *Ger.*: das Vorbewusste; *It.*: il Preconscio; *Port.*: o Pré-consciente; *Span.*: el Preconsciente.

**pregenital**

*Fr.*: pré-génital; *Ger.*: prägenital; *It.*: pregenitale; *Port.*: pregenital *Span.*: pregenital.

**pregnancy, fantasy of**

*Fr.*: fantasme de grossesse; *Ger.*: Schwangerschaftsphantasie; *It.*: fantasia di gravidanza; *Port.*: fantasia de gravidez; *Span.*: fantasía de embarazo.

**prehistory**

*Fr.*: préhistoire; *Ger.*: Vorgeschichte; *It.*: preistoria; *Port.*: pré-história; *Span.*: prehistoria.

**premonitory dream**

*Fr.*: rêve prémonitoire; *Ger.*: prämonitorischer Traum; *It.*: sogno premonitore; *Port.*: sonho premonitório; *Span.*: sueño premonitorio.

**prepsychosis**

*Fr.*: prépsychose; *Ger.*: Präpsychose; prepsicosis; *It.*: prepsicosi; *Port.*: pré-psicose; *Span.*: prepsicosis.

**prereflective unconscious**

*Fr.*: inconscient pré-réfléchi; *Ger.*: präreflektives Unbewusstes; *It.*: inconscio preriflessivo; *Port.*: inconsciente pré-reflexivo; *Span.*: inconsciente prereflexivo.

**primal, the**

*Fr.*: originaire (l'); *Ger.*: originär, das Ursprüngliche; *It.*: l'originario; *Port.*: o originário; *Span.*: lo originario.

**primal fantasies**

*Fr.*: fantasmes originaires; *Ger.*: Urphantasien; *It.*: fantasmi originari; *Port.*: profantasia/fantasia primitivas, fantasias originárias. *Span.*: profantasia/fantasia originarias.

**primal repression**

*Fr.*: refoulement originaire; *Ger.*: Urverdrängung; *It.*: rimozione originaria; *Port.*: recalque (recalcamento)

primitivo/recalque (recalcamento) originário; *Span.*: represión primaria/represión originaria.

**primal scene**

*Fr.*: scène originaire (scène primitive); *Ger.*: Urszene; *It.*: scena originaria, scena primari; *Port.*: cena primitiva, cena originária; *Span.*: escena primaria, escena originaria.

**primary identification**

*Fr.*: identification primaire; *Ger.*: primäre Identifizierung; *It.*: identificazione primaria; *Port.*: identificação primária; *Span.*: identificación primaria.

**primary love**

*Fr.*: amour primaire; *Ger.*: primäre Liebe; *It.*: amore primario; *Port.*: amor primário; *Span.*: amor primario.

**primary masochism**

*Fr.*: masochisme primaire; *Ger.*: primärer Masochismus; *It.*: masochismo primario; *Port.*: masoquismo primário; *Span.*: masoquismo primario.

**primary narcissism**

*Fr.*: narcissisme primaire; *Ger.*: primärer Narzissmus; *It.*: narcisismo primario; *Port.*: narcisismo primário; *Span.*: narcisismo primario.

**primary need**

*Fr.*: besoin primaire; *Ger.*: Grundbedürfnis; *It.*: bisogno primario; *Port.*: necessidade primária; *Span.*: necesidad primaria.

**primary object**

*Fr.*: objet primaire; *Ger.*: Primärobjekt; *It.*: oggetto primario; *Port.*: objecto primário; *Span.*: objeto primario.

**primary process/secondary process**

*Fr.*: processus primaire, processus secondaire ; *Ger.*: Primärvorgang, Sekundärvorgang; *It.*: processo primario, processo secundario; *Port.*: processo primário, processo secundário; *Span.*: proceso primario, proceso secundario.

**primitive**

*Fr.*: primitif; *Ger.*: primitiv; *It.*: primitivo; *Port.*: primitivo; *Span.*: primitivo.

**primitive agonies**

*Fr.*: agonies primitives; *Ger.*: primitive Agonien; *It.*: agonia primitiva; *Port.*: agonias primitivas; *Span.*: agonias primitivas.

**primitive horde**

*Fr.*: horde primitive; *Ger.*: Urhorde; *It.*: orda primordiale; *Port.*: horda primitiva; *Span.*: horda primitiva.

**principle**

*Fr.*: principe; *Ger.*: Prinzip; *It.*: principio; *Port.*: princípio; *Span.*: principio.

**principle of constancy**

*Fr.*: principe de constance; *Ger.*: Konstanzprinzip; *It.*: principio di costanza; *Port.*: princípio de constância; *Span.*: principio de constancia.

**principle of identity preservation**

*Fr.*: principe d'identité; *Ger.*: Identitätsprinzip; *It.*: principio di identità; *Port.*: princípio de identidade; *Span.*: principio de identidad.

**principle of (neuronal) inertia**

*Fr.*: principe d'inertie (des neurones); *Ger.*: Trägheitssprinzip (Prinzip der Neuronenträgheit); *It.*: principio di inerzia (neuronica); *Port.*: princípio de inércia (neuronal); *Span.*: principio de inercia (neuronal).

**privation**

*Fr.*: privation; *Ger.*: Entbehrung/Entzug; *It.*: privazione; *Port.*: privação; *Span.*: privación.

**process**

*Fr.*: processus; *Ger.*: Prozess, Vorgang; *It.*: processo; *Port.*: processo; *Span.*: proceso.

**progressive neutralization**

*Fr.*: neutralisation progressive; *Ger.*: progressive Neutralisierung; *It.*: neutralizzazione progressiva; *Port.*: neutralização progressiva; *Span.*: neutralización progresiva.

**prohibition**

*Fr.*: interdit; *Ger.*: verboten, Verbot; *It.*: interdetto, interdizione; *Port.*: proibido, proibição; *Span.*: prohibido, prohibición.

**projection**

*Fr.*: projection; *Ger.*: Projektion; *It.*: proiezione; *Port.*: projecção; *Span.*: proyección.

**projection and "participation mystique"**

*Fr.*: projection et "participation mystique"; *Ger.*: Projektion und "participation mystique"; *It.*: proiezione e partecipazione mistica; *Port.*: projecção e "participação mística"; *Span.*: proyección y "participación mística."

**projective identification**

*Fr.*: identification projective; *Ger.*: projektive Identifizierung; *It.*: identificazione proiettiva; *Port.*: identificação projectiva; *Span.*: identificación proyectiva.

**protective shield**

*Fr.*: pare-excitations; *Ger.*: Reizschutz; *It.*: parastimoli o schermo antistimolo; *Port.*: pára-excitações; *Span.*: protector o protección contra las excitaciones o los estímulos.

**prot Thoughts**

*Fr.*: protopensées; *Ger.*: Protogedanken; *It.*: protopensieri; *Port.*: proto-pensamentos; *Span.*: proto-pensamientos.

**psyche/psychism**

*Fr.*: psychisme; *Ger.*: Psyche; *It.*: psichismo; *Port.*: psi-quismo; *Span.*: psiquismo.

**psychic apparatus**

*Fr.*: appareil psychique; *Ger.*: psychischer/seelischer Apparat; *It.*: apparato psichico; *Port.*: aparelho psíquico/mental; *Span.*: aparato psíquico.

**psychic causality**

*Fr.*: causalité psychique; *Ger.*: psychische Kausalität; *It.*: causalità psichica; *Port.*: causalidade psíquica; *Span.*: causalidad psíquica.

**psychic envelope**

*Fr.*: enveloppes psychiques; *Ger.*: psychische Hülle; *It.*: involucri psichici; *Port.*: invólucros psíquicos; *Span.*: envolturas psíquicas.

**psychic reality**

*Fr.*: réalité psychique; *Ger.*: psychische Realität; *It.*: realtà psichica; *Port.*: realidade psíquica; *Span.*: realidad psíquica.

**psychic representative**

*Fr.*: représentant psychique; *Ger.*: psychische Repräsentanz, psychische Repräsentant; *It.*: rappresentante psichico; *Port.*: representante psíquico; *Span.*: representante psíquico.

**psychic structure**

*Fr.*: structure psychique; *Ger.*: psychische Struktur; *It.*: struttura psichica; *Port.*: estrutura psíquica; *Span.*: estructura psíquica.

**psychic temporality**

*Fr.*: temporalité psychique; *Ger.*: psychische Zeitlichkeit; *It.*: temporalità psichica; *Port.*: temporalidade psíquica; *Span.*: temporalidad psíquica.

**psychoanalysis**

*Fr.*: psychanalyse; *Ger.*: Psychoanalyse; *It.*: psicoanalisi; *Port.*: psicanálise; *Span.*: psicoanálisis.

**psychoanalyst**

*Fr.*: psychanalyste; *Ger.*: Psychoanalytiker; *It.*: psicoanalista; *Port.*: psicanalista; *Span.*: psicoanalista.

**psychoanalytic technique**

*Fr.:* technique psychanalytique; *Ger.:* psychoanalytische Technik; *It.:* tecnica psicoanalitica; *Port.:* técnica psicanalítica; *Span.:* técnica psicoanalítica.

**psychoanalytic treatment**

*Fr.:* cure psychanalytique; *Ger.:* Psychoanalytische Kur; *It.:* cura psicoanalitica; *Port.:* cura psicanalítica; *Span.:* cura psicoanalítica.

**psychobiography**

*Fr.:* psychobiographie; *Ger.:* Psychobiographie; *It.:* psicobiografia; *Port.:* psicobiografia; *Span.:* psicobiografía.

**psychodrama**

*Fr.:* psychodrame; *Ger.:* Psychodrama; *It.:* psicodramma; *Port.:* psicodrama; *Span.:* psicodrama.

**psychogenesis/organogenesis**

*Fr.:* psychogenèse/organogenèse; *Ger.:* Psychogenese/Organogenese; *It.:* psicogenesi/organogenesi; *Port.:* psicogênese/organogênese; *Span.:* psicogénesis/organogénesis.

**psychohistory**

*Fr.:* psychohistoire; *Ger.:* Psychogeschichte; *It.:* psicotoria; *Port.:* psico-história; *Span.:* psicohistoria.

**psychological tests**

*Fr.:* tests psychologiques; *Ger.:* psychologische Tests; *It.:* test psicologici; *Port.:* testes psicológicos; *Span.:* tests psicológicos.

**psychological types**

*Fr.:* types psychologiques; *Ger.:* psychologische Typen; *It.:* tipi psicologici; *Port.:* tipos psicológicos; *Span.:* tipos psicológicos.

**psychoses, chronic and delusional**

*Fr.:* psychoses chroniques et délirantes; *Ger.:* chronische und wahnhafte Psychosen; *It.:* psicosi croniche e deliranti; *Port.:* psicoses crônicas e delirantes; *Span.:* psicosis crónicas y delirantes.

**psychosexual development**

*Fr.:* développement psychosexuel; *Ger.:* psychosexuelle Entwicklung; *It.:* sviluppo psicosessuale; *Port.:* desenvolvimento psicosexual; *Span.:* desarrollo psicosexual.

**psychosomatic**

*Fr.:* psychosomatique; *Ger.:* psychosomatisch; *It.:* psicosomatica; *Port.:* psicossomática; *Span.:* psicossomática.

**psychosomatic limit/boundary**

*Fr.:* limite psychosomatique; *Ger.:* psychosomatische Grenze; *It.:* limite psicosomatico; *Port.:* limite psicossomático; *Span.:* límite psicossomático.

**psychotherapy**

*Fr.:* psychothérapie; *Ger.:* Psychotherapie; *It.:* psicoterapia; *Port.:* psicoterapia; *Span.:* psicoterapia.

**psychotic defenses**

*Fr.:* défenses psychotiques; *Ger.:* psychotische Abwehr(mechanismen); *It.:* difese psicotiche; *Port.:* defesas psicóticas; *Span.:* defensas psicóticas.

**psychotic/neurotic**

*Fr.:* psychotique/névrotique; *Ger.:* psychotisch/neurotisch; *It.:* psicotico/nevrotico; *Port.:* psicótico/neurótico; *Span.:* psicótico/neurótico.

**psychotic panic**

*Fr.:* panique psychotique; *Ger.:* psychotische Angst; *Span.:* pánico psicótico; *It.:* panico psicotico; *Port.:* pânico psicótico.

**psychotic part of the personality**

*Fr.:* partie psychotique de la personnalité; *Ger.:* psychotischer Persönlichkeitsanteil; *It.:* parte psicotica della personalità; *Port.:* parte psicótica da personalidade; *Span.:* parte psicótica de la personalidad.

**psychotic potential**

*Fr.:* potentialité psychotique; *Ger.:* psychotisches Potential; *It.:* potenzialità psicotica; *Port.:* potencialidade psicótica; *Span.:* potencialidad psicótica.

**psychotic transference**

*Fr.:* transfert psychotique; *Ger.:* psychotische Übertragung; *It.:* transfert psicotico; *Port.:* transferência psicótica; *Span.:* transferencia psicótica.

**puberty**

*Fr.:* puberté; *Ger.:* Pubertät (-szeit); *It.:* pubertà; *Port.:* puberdade; *Span.:* pubertad.

**puerperal psychoses**

*Fr.:* psychoses puerpérales; *Ger.:* puerperale Psychosen; *Span.:* psicosis puerperales; *It.:* psicosi puerperali; *Port.:* psicoses puerperais.

**punishment dream**

*Fr.:* rêve de punition; *Ger.:* Strafraum; *It.:* sogno di punizione; *Port.:* sonho de punição; *Span.:* sueño punitivo.

**purified-pleasure-Ego**

*Fr.*: Moi-plaisir purifié; *Ger.*: purifiziertes Lust-Ich; *It.*: Io-piacere purificato; *Port.*: Eu-prazer-purificado; *Span.*: Yo-placer purificado.

**purposive idea**

*Fr.*: représentation-but (représentation de but); *Ger.*: Zielvorstellung; *It.*: rappresentazione finalizzata; *Port.*: representação-meta; *Span.*: representación-meta.

**quantative/qualitative**

*Fr.*: quantitatif/qualitatif; *Ger.*: quantitativ/qualitativ; *It.*: quantitativo/qualitativo; *Port.*: quantitativo/ qualitativo; *Span.*: cuantitativo/cualitativo.

**quasi-independence/transitional stage**

*Fr.*: quasi-indépendance; *Ger.*: Quasiunabhängigkeit; *It.*: quasi-indipendenza; *Port.*: quase-independência; *Span.*: cuasi-independencia.

**rationalization**

*Fr.*: rationalisation; *Ger.*: Rationalisierung; *It.*: razionalizzazione; *Port.*: racionalização; *Span.*: racionalización.

**reaction-formation**

*Fr.*: formation réactionnelle; *Ger.*: Reaktionsbildung; *It.*: formazione reattiva; *Port.*: formação reactiva; *Span.*: formación reactiva.

**reality principle**

*Fr.*: principe de réalité; *Ger.*: Realitätsprinzip; *It.*: principio di realtà; *Port.*: princípio de realidade; *Span.*: principio de realidad.

**realization**

*Fr.*: réalisation; *Ger.*: Realisierung; *It.*: realizzazione; *Port.*: realização; *Span.*: realización.

**Real, the**

*Fr.*: réel (le -); *Ger.*: das Reale; *It.*: il Reale; *Port.*: o real; *Span.*: lo real.

**real trauma**

*Fr.*: traumatisme réel; *Ger.*: reales Trauma; *It.*: trauma reale; *Port.*: traumatismo real; *Span.*: traumatismo real.

**Real, Symbolic, and Imaginary father**

*Fr.*: Père réel, imaginaire et symbolique; *Ger.*: realer, imaginärer, symbolischer Vater; *It.*: Padre reale, immaginario, simbolico; *Port.*: Pai real, imaginário, simbólico. ; *Span.*: Padre real, imaginario, simbólico.

**reciprocal paths of influence**

*Fr.*: voies d'influence réciproque; *Ger.*: wechselseitige Einflussnahme; *It.*: vie di influenza reciproca; *Port.*: vias de influência recíproca; *Span.*: vías de influencia recíproca.

**regression**

*Fr.*: régression; *Ger.*: Regression; *It.*: regressione; *Port.*: regressão; *Span.*: regresión.

**relations (commensalism, parasitism, symbiosis)**

*Fr.*: relations (commensalisme, symbiose, parasitisme); *Ger.*: Beziehungen (Kommensalismus, Parasitismus, Symbiose); *It.*: rapporti (convivialità, simbiosi, parasitismo); *Port.*: relações (comensalismo, parasitismo, simbiose); *Span.*: relaciones (comensalismo, parasitismo, simbiosis).

**relaxation principle and neo-catharsis**

*Fr.*: principe de relaxation et néocatharsis; *Ger.*: Relaxationsprinzip und Neokatharsis; *It.*: principio di distensione e neocatarsi; *Port.*: princípio de relaxamento e neocatarse; *Span.*: principio de relajación y neocatarsis.

**relaxation psychotherapy**

*Fr.*: relaxation (psychothérapie de -); *Ger.*: Entspannungstherapie; *It.*: psicoterapia di rilassamento; *Port.*: psicoterapia de relaxamento; *Span.*: psicoterapia de relajación.

**remembering**

*Fr.*: remémoration; *Ger.*: Erinnerungsvorgang/Erinnern/Wiedererinnern; *It.*: rimemorazione; *Port.*: rememoração; *Span.*: rememoración.

**reminiscence**

*Fr.*: réminiscences; *Ger.*: Reminiszenz; *It.*: reminiscenze; *Port.*: reminiscência; *Span.*: reminiscencias.

**reparation**

*Fr.*: réparation; *Ger.*: Wiedergutmachung; *It.*: riparazione; *Port.*: reparação; *Span.*: reparación.

**repetition**

*Fr.*: répétition; *Ger.*: Wiederholung; *It.*: ripetizione; *Port.*: repetição; *Span.*: repetición.

**repetition compulsion**

*Fr.*: répétition (compulsion de -); *Ger.*: Wiederholungszwang; *It.*: coazione a ripetere; *Port.*: compulsão à repetição; *Span.*: compulsión a la repetición.

**repetitive dream**

*Fr.*: rêve répétitif; *Ger.*: Wiederholungstraum; *It.*: sogno ripetitivo; *Port.*: sonho repetitivo; *Span.*: sueño repetitivo.

**representability**

*Fr.*: figurabilité; *Ger.*: Darstellbarkeit; *It.*: rappresentabilità, (raf)figurabilità; *Port.*: figurabilidade/representabilidade; *Span.*: figurabilidad.

**representative**

*Fr.*: représentation; *Ger.*: Vertretung, Repräsentanz; *It.*: rappresentanza; *Port.*: representância; *Span.*: representancia.

**representation of affect**

*Fr.*: représentation d'affect; *Ger.*: Affektrepräsentanz; *It.*: rappresentazione d'affetto; *Port.*: representação de afecto; *Span.*: representación de afecto.

**representation/presentation/idea**

*Fr.*: représentation; *Ger.*: Vorstellung/Idee/Repräsentanz; *It.*: rappresentazione; *Port.*: representação; *Span.*: representación.

**repressed**

*Fr.*: refoulé; *Ger.*: verdrängt, das Verdrängte; *It.*: rimosso; *Port.*: recalcado; *Span.*: reprimido.

**repression**

*Fr.*: refoulement; *Ger.*: Verdrängung; *It.*: rimozione; *Port.*: recalque, recalçamento; *Span.*: represión.

**repression, lifting of**

*Fr.*: refoulement (levée du -); *Ger.*: Aufhebung der Verdrängung; *It.*: abolizione/superamento della rimozione; *Port.*: levantamento do recalque; *Span.*: levantamiento de la represión.

**repudiation**

*Fr.*: rejet; *Ger.*: Verwerfung, Ablehnung; *It.*: rigetto; *Port.*: rejeição; *Span.*: repudio.

**rescue fantasies**

*Fr.*: fantômes de sauvetage; *Ger.*: Rettungsphantasien; *It.*: fantasia di salvataggio; *Port.*: fantasias de resgate; *Span.*: fantasías de rescate.

**resistance**

*Fr.*: résistance; *Ger.*: Widerstand; *It.*: resistenza; *Port.*: resistência; *Span.*: resistencia.

**resolution of the transference**

*Fr.*: transfert (résolution [ou liquidation] du -); *Ger.*: Auflösung der Übertragung; *It.*: risoluzione del transfert; *Port.*: resolução da transferência; *Span.*: resolución de la transferencia.

**return of the repressed**

*Fr.*: refoulé (retour du -); *Ger.*: Wiederkehr des Verdrängten, Rückkehr des Verdrängten; *It.*: ritorno del rimosso; *Port.*: retorno do recalcado; *Span.*: retorno de lo reprimido.

**reverie**

*Fr.*: rêverie (rêve diurne); *Ger.*: Tagtraum; *It.*: fantasticheria, sogno a occhi aperti; *Port.*: sonho diurno, devaneio; *Span.*: sueño diurno (devaneo).

**reversal into the opposite**

*Fr.*: renversement; *Ger.*: Umkehrung/Verwandlung ins Gegenteil; *It.*: trasformazione nel contrario; *Port.*: transformação no seu contrário; *Span.*: transformación en lo contrario/conversión en lo contrario.

**rite, ritual**

*Fr.*: rite, rituel; *Ger.*: Ritus, Ritual (rituell, Zeremoniell); *It.*: rito, rituale; *Port.*: rito, ritual; *Span.*: rito, ritual.

**rivalry**

*Fr.*: rivalité; *Ger.*: Rivalität; *It.*: rivalità; *Port.*: rivalidade; *Span.*: rivalidad.

**sadism**

*Fr.*: sadisme; *Ger.*: Sadismus; *It.*: sadismo; *Port.*: sadismo; *Span.*: sadismo.

**sadomasochism**

*Fr.*: sado-masochisme; *Ger.*: Sadomasochismus; *It.*: sadomasochismo; *Port.*: sado-masiquismo; *Span.*: sado-masiquismo.

**schizophrenia**

*Fr.*: schizophrénie; *Ger.*: Schizophrenie; *It.*: schizofrenia; *Port.*: esquizofrenia; *Span.*: esquizofrenia.

**screen memory**

*Fr.*: souvenir-écran; *Ger.*: Deckerinnerung; *It.*: ricordo di copertura; *Port.*: recordação encobridora; *Span.*: recuerdo encubridor.

**secondary narcissism**

*Fr.*: narcissisme secondaire; *Ger.*: sekundärer Narzissmus; *It.*: narcisismo secondario; *Port.*: narcisismo secundário; *Span.*: narcisismo secundario.

**secondary revision**

*Fr.*: élaboration secondaire; *Ger.*: sekundäre Bearbeitung, sekundäre Ausarbeitung; *It.*: elaborazione secondaria; *Port.*: elaboração secundária; *Span.*: elaboración secundaria.

**secret**

*Fr.*: secret; *Ger.*: Geheimnis; *It.*: segreto; *Port.*: segredo; *Span.*: secreto.

**seduction**

*Fr.*: séduction; *Ger.*: Verführung; *It.*: seduzione; *Port.*: sedução; *Span.*: seducción.



**seduction scenes**

*Fr.*: séduction (scènes de -); *Ger.*: Verführungsszenen; *It.*: scene di seduzione; *Port.*: cenas de sedução; *Span.*: escenas de seducción.

**selected fact**

*Fr.*: fait choisi; *Ger.*: ausgewählte Tatsache; *It.*: fatto scelto; *Port.*: facto selecionado; *Span.*: hecho seleccionado.

**self**

*Fr.*: Self (Soi); *Ger.*: Selbst; *It.*: Sé; *Port.*: si; *Span.*: sí.

**self analysis**

*Fr.*: autoanalyse; *Ger.*: Selbstanalyse; *It.*: autoanalisi; *Port.*: auto-análise; *Span.*: autoanálisis.

**self-consciousness**

*Fr.*: conscience de soi; *Ger.*: Selbstbewusstsein; *It.*: autocoscienza; *Port.*: consciência de si mesmo; *Span.*: conciencia de sí.

**self-esteem**

*Fr.*: estime de soi; *Ger.*: Selbstachtung; *It.*: autostima; *Port.*: auto-estima; *Span.*: sentimiento de sí, autoestima.

**self-hatred**

*Fr.*: haine de soi; *Ger.*: Selbsthass; *It.*: odio di sé; *Port.*: ódio de si próprio; *Span.*: odio de sí mismo.

**self-image**

*Fr.*: image de soi; *Ger.*: Selbstbild; *It.*: immagine di sé; *Port.*: imagem de si mesmo; *Span.*: imagen de sí.

**self-mutilation**

*Fr.*: automutilation; *Ger.*: Selbstverstümmelung; *It.*: automutilazione; *Port.*: automutilação; *Span.*: automutilación.

**self-object**

*Fr.*: Selfobjet; *Ger.*: Selbstobjekt; *It.*: oggetto-Sé; *Port.*: self-objecto; *Span.*: self objeto.

**self-preservation**

*Fr.*: autoconservation; *Ger.*: Selbsterhaltung; *It.*: autoconservazione; *Port.*: autoconservação; *Span.*: autoconservación.

**Self psychology**

*Fr.*: psychologie du Self; *Ger.*: Selbst-Psychologie; *It.*: psicologia del Sé; *Port.*: psicologia do Self; *Span.*: psicología del Self.

**self-punishment**

*Fr.*: autopunition; *Ger.*: Selbstbestrafung; *It.*: autopunizione; *Port.*: auto-punição; *Span.*: autopunición.

**self-representation**

*Fr.*: représentation de soi; *Ger.*: Selbstrepräsentanz; *It.*: rappresentazione di sé; *Port.*: representação de si; *Span.*: representación del self.

**self (true/ false)**

*Fr.*: Self (vrai/faux); *Ger.*: Selbst (wahres/falsches); *It.*: Sé (vero/falso); *Port.*: self (verdadeiro/falso); *Span.*: self (verdadero/falso).

**sense/nonsense**

*Fr.*: sens/non-sens; *Ger.*: Sinn/Unsinn; *It.*: senso/non senso; *Port.*: sentido/sem sentido; *Span.*: sentido/sinsentido.

**sense of smell**

*Fr.*: odorat; *Ger.*: Geruchssinn; *It.*: olfatto; *Port.*: olfacto; *Span.*: olfato.

**sexual differences**

*Fr.*: différenciation sexuelle/sexuée; *Ger.*: Geschlechtsdifferenzierung/geschlechtliche Differenzierung; *It.*: differenziazione sessuale/di genere; *Port.*: diferenciação sexual/sexuada; *Span.*: diferenciación sexual/sexuada.

**sexual instinct**

*Fr.*: pulsion sexuelle; *Ger.*: Sexualtrieb/Geschlechtstrieb; *It.*: pulsione sessuale; *Port.*: pulsão sexual; *Span.*: pulsión sexual.

**sexuality**

*Fr.*: sexualité; *Ger.*: Sexualität; *It.*: sessualità; *Port.*: sexualidade; *Span.*: sexualidad.

**sexualization**

*Fr.*: sexualisation; *Ger.*: Sexualisierung; *It.*: sessualizzazione; *Port.*: sexualização; *Span.*: sexualización.

**sexual theories of children**

*Fr.*: théories sexuelles infantiles; *Ger.*: infantile Sexualtheorien; *Span.*: teorías sexuales infantiles; *It.*: teorie sessuali infantili; *Port.*: teorias sexuais infantis.

**sexual trauma**

*Fr.*: traumatisme sexuel; *Ger.*: sexuelles Trauma; *It.*: trauma sessuale; *Port.*: traumatismo sexual. *Span.*: traumatismo sexual.

**sexuation**

*Fr.*: sexuation (formules de la -); *Ger.*: Sexuierung; *Span.*: fórmulas de la sexuación; *It.*: formule della sessuazione; *Port.*: fórmulas da sexuação.

**shadow**

*Fr.*: ombre; *Ger.*: Schatten; *It.*: ombra; *Port.*: sombra; *Span.*: sombra.

**shame**

*Fr.*: honte; *Ger.*: Scham; *It.*: vergogna; *Port.*: vergonha; *Span.*: vergüenza.

**signifier**

*Fr.*: signifiant; *Ger.*: Signifikant; *It.*: significante; *Port.*: significante; *Span.*: significante.

**signifier/signified**

*Fr.*: signifiant/signifié; *Ger.*: Signifikant/Signifikat; *It.*: significante/significato; *Port.*: significante/significado; *Span.*: significante/significado.

**signifying chain**

*Fr.*: chaîne signifiante; *Ger.*: Signifikantenkette; *It.*: catena significante; *Port.*: cadeia significante; *Span.*: cadena significante.

**silence**

*Fr.*: silence; *Ger.*: Schweigen; *It.*: silenzio; *Port.*: silêncio; *Span.*: silencio.

**skin**

*Fr.*: peau; *Ger.*: Haut; *It.*: pelle; *Port.*: pele; *Span.*: piel.

**skin-ego**

*Fr.*: Moi-peau; *Ger.*: Haut-Ich; *It.*: Io-pelle; *Port.*: Eu-pele; *Span.*: Yo-piel.

**sleep/wakefulness**

*Fr.*: sommeil/veille; *Ger.*: Schlaf/Wachen; *It.*: sonno/veglia; *Port.*: sono/vigília; *Span.*: sueño/vigilia.

**slips of the tongue**

*Fr.*: lapsus; *Ger.*: Lapsus; *It.*: lapsus; *Port.*: lapso; *Span.*: lapsus.

**somatic compliance**

*Fr.*: complaisance somatique; *Ger.*: somatisches Entgegenkommen; *It.*: compiacenza somatica; *Port.*: complacência somática; *Span.*: complacencia somática.

**somnambulism**

*Fr.*: somnambulisme; *Ger.*: Somnambulismus; *It.*: sonnambulismo; *Port.*: sonambulismo; *Span.*: sonambulismo.

**specific action**

*Fr.*: action spécifique ; *Ger.*: spezifische Aktion *It.*: azione specifica; *Port.*: acção específica; *Span.*: acción específica.

**splitting**

*Fr.*: clivage; *Ger.*: Spaltung; *It.*: scissione; *Port.*: clivagem; *Span.*: escisión.

**splitting of the ego**

*Fr.*: Moi (clivage du -); *Ger.*: Ichspaltung; *It.*: scissione dell'Io; *Port.*: clivagem do Eu; *Span.*: escisión del Yo.

**splitting of the object**

*Fr.*: clivage de l'objet; *Ger.*: Objektspaltung; *It.*: scissione dell'oggetto; *Port.*: clivagem do objecto; *Span.*: escisión del objeto.

**splitting of the subject**

*Fr.*: refente; *Ger.*: Spaltung; *It.*: scissione; *Port.*: cisão; *Span.*: escisión.

**squiggle**

*Fr.*: squiggle (“gribouillis”); *Ger.*: Schnörkel; *It.*: scarabocchio; *Port.*: garatuja; *Span.*: garabato.

**stage (or phase)**

*Fr.*: stade; *Ger.*: Stufe; *It.*: fase, stadio; *Port.*: fase, estádio; *Span.*: fase/estadio.

**stammering**

*Fr.*: bégaiement; *Ger.*: Stottern; *It.*: balbuzie; *Port.*: gaguez; *Span.*: tartamudeo.

**stranger**

*Fr.*: étranger (peur, angoisse devant l’-); *Ger.*: Fremdenangst; *It.*: angoscia, paura dell’estraneo; *Port.*: angústia diante do estranho; *Span.*: miedo, angustia ante lo extraño.

**strata/stratifications**

*Fr.*: strates et stratifications; *Ger.*: Schichten und Schichtungen; *It.*: strati e stratificazione; *Port.*: estratos e estratificações; *Span.*: estratos y estratificaciones.

**structural theory**

*Fr.*: structurale (théorie -); *Ger.*: Strukturtheorie; *It.*: teoria strutturale; *Port.*: teoria estrutural; *Span.*: teoría estructural.

**subconscious**

*Fr.*: subconscient; *Ger.*: unterbewusst, das Unterbewusste; *It.*: subconscio; *Port.*: subconsciente; *Span.*: subconsciente.

**subject**

*Fr.*: sujet; *Ger.*: Subjekt; *It.*: soggetto; *Port.*: sujeito; *Span.*: sujeto.

**subject of the unconscious**

*Fr.*: sujet de l'inconscient; *Ger.*: Subjekt des Unbewussten; *It.*: soggetto dell'inconscio; *Port.*: sujeito do inconsciente; *Span.*: sujeto del inconsciente.

**sublimation**

*Fr.*: sublimation; *Ger.*: Sublimierung; *It.*: sublimazione; *Port.*: sublimação; *Span.*: sublimación.

**substitute**

*Fr.*: substitut; *Ger.*: Ersatz; *It.*: sostituto; *Port.*: substituto; *Span.*: sustituto.

**substitutive formation**

*Fr.*: formation substitutive; *Ger.*: Ersatzbildung; *It.*: formazione sostitutiva; *Port.*: formação substitutiva; *Span.*: formación sustitutiva/formación sustituta.

**sucking/thumbsucking**

*Fr.*: succion; *Ger.*: Saugen; *It.*: suzione; *Port.*: sucção; *Span.*: succión.

**sudden involuntary idea**

*Fr.*: idée subite involontaire; *Ger.*: Einfall; *It.*: idea improvvisa involontaria; *Port.*: ideia súbita involuntária; *Span.*: idea súbita involuntaria.

**suffering**

*Fr.*: souffrance; *Ger.*: Leiden; *It.*: sofferenza; *Port.*: sofrimento; *Span.*: sufrimiento.

**suggestion**

*Fr.*: suggestion; *Ger.*: Suggestion; *It.*: suggestione; *Port.*: sugestão; *Span.*: sugestión.

**suicidal behavior**

*Fr.*: suicidaires (conduites); *Ger.*: suizidales Verhalten; *It.*: condotte suicidarie; *Port.*: condutas suicidárias; *Span.*: conductas suicidas.

**suicide**

*Fr.*: suicide; *Ger.*: Selbstmord; *It.*: suicidio; *Port.*: suicídio; *Span.*: suicidio.

**sum of excitation**

*Fr.*: somme d'excitation; *Ger.*: Erregungssumme; *It.*: somma di eccitamento; *Port.*: soma de excitação; *Span.*: suma de excitación.

**superego**

*Fr.*: Surmoi; *Ger.*: Über-Ich; *It.*: Super-Io; *Port.*: super-Eu; *Span.*: Superyo.

**signal anxiety**

*Fr.*: angoisse-signal; *Ger.*: Angst als Signal; *It.*: segnale d'angoscia; *Port.*: angústia-sinal; *Span.*: angustia señal.

**symbiosis, symbiotic relation**

*Fr.*: symbiose, relation symbiotique; *Ger.*: Symbiose, symbiotische Beziehung; *It.*: simbiosi, relazione simbiotica; *Port.*: simbiose, relação simbiótica; *Span.*: simbiosis, relación simbiótica.

**symbol**

*Fr.*: symbole; *Ger.*: Symbol; *It.*: simbolo; *Port.*: símbolo; *Span.*: símbolo.

**symbolic equation**

*Fr.*: équation symbolique; *Ger.*: symbolische Gleichung; *It.*: equazione simbolica; *Port.*: equação simbólica; *Span.*: ecuación simbólica.

**symbolic realization**

*Fr.*: réalisation symbolique; *Ger.*: symbolische Realisierung; *It.*: realizzazione simbolica; *Port.*: realização simbólica; *Span.*: realización simbólica.

**symbolic, the**

*Fr.*: symbolique (le -); *Ger.*: das Symbolische; *It.*: il Simbolico; *Port.*: o simbólico; *Span.*: lo simbólico.

**symbolism**

*Fr.*: symbolisme; *Ger.*: Symbolik; *It.*: simbolismo; *Port.*: simbolismo; *Span.*: simbolismo.

**symbolization**

*Fr.*: symbolisation (processus de -); *Ger.*: Symbolisierung; *It.*: processo di simbolizzazione; *Port.*: simbolização; *Span.*: proceso de simbolización.

**symptom**

*Fr.*: symptôme; *Ger.*: Symptom; *Span.*: síntoma; *It.*: sintomo; *Port.*: sintoma.

**symptom formation**

*Fr.*: symptôme (formation de -); *Ger.*: Symptombildung; *It.*: formazione del sintomo; *Port.*: formação de sintoma; *Span.*: formación del síntoma.

**symptom/sinthome**

*Fr.*: sinthome; *Ger.*: Sinthome; *It.*: sinthomo; *Port.*: sintoma; *Span.*: sintom.

**synchronicity**

*Fr.*: synchronicité; *Ger.*: Synchronizität; *It.*: sincronicità; *Port.*: sincronicidade; *Span.*: sincronicidad.

**system, systemic**

*Fr.*: système, systémique; *Ger.*: System, systemisch; *It.*: sistema, sistemico; *Port.*: sistema, sistêmico; *Span.*: sistema, sistémico.

**taboo**

*Fr.*: tabou; *Ger.*: Tabu; *It.*: tabù; *Port.*: tabu; *Span.*: tabú.

**tact**

*Fr.*: tact; *Ger.*: Takt; *It.*: tatto; *Port.*: tacto; *Span.*: tacto.

**telepathy**

*Fr.*: télépathie; *Ger.*: Telepathie, Gedankeninduktion; *It.*: telepatia; *Port.*: telepatia; *Span.*: telepatía.

**tenderness**

*Fr.*: tendresse; *Ger.*: Zärtlichkeit; *It.*: tenerezza; *Port.*: ternura; *Span.*: ternura.

**therapeutic alliance**

*Fr.:* alliance thérapeutique; *Ger.:* therapeutisches Arbeitsbündnis; *It.:* alleanza terapeutica; *Port.:* aliança terapêutica; *Span.:* alianza terapéutica.

**thing-presentation**

*Fr.:* représentation de chose; *Ger.:* Sachvorstellung, Dingvorstellung; *It.:* rappresentazione di cosa; *Port.:* representação de coisa; *Span.:* representación de cosa.

**Thing, the**

*Fr.:* Chose (la); *Ger.:* das Ding, die Sache; *It.:* la Cosa; *Port.:* a Coisa; *Span.:* la Cosa.-

**thought**

*Fr.:* pensée; *Ger.:* Gedanke; *It.:* pensiero; *Port.:* pensamento; *Span.:* pensamiento.

**thought identity**

*Fr.:* identité de pensée; *Ger.:* Denkidentität; *It.:* identità di pensiero; *Port.:* identidade de pensamento; *Span.:* identidad de pensamiento.

**thought-thinking apparatus**

*Fr.:* appareil à penser les pensées; *Ger.:* Apparat zum Denken von Gedanken; *It.:* apparato per pensare i pensieri; *Port.:* aparelho para pensar os pensamentos; *Span.:* aparato para pensar los pensamientos.

**tic**

*Fr.:* tic; *Ger.:* Tick/nervöses Zucken; *It.:* tic; *Port.:* tique; *Span.:* tic.

**time**

*Fr.:* temps; *Ger.:* Zeit; *It.:* tempo; *Port.:* tempo; *Span.:* tiempo.

**topographical point of view**

*Fr.:* topique (point de vue -); *Ger.:* topischer Gesichtspunkt; *It.:* punto di vista topico; *Port.:* ponto de vista tópic; *Span.:* punto de vista tópico.

**topology**

*Fr.:* topologie; *Ger.:* Topologie; *It.:* topologia; *Port.:* topologia; *Span.:* topología.

**totem, totemism**

*Fr.:* totem, totémisme; *Ger.:* Totem, Totemismus; *It.:* totem, totemismo; *Port.:* tótem, totemismo; *Span.:* totem, totemismo.

**training analysis**

*Fr.:* psychanalyse didactique; *Ger.:* Lehranalyse; *It.:* psicoanalisi didattica; *Port.:* psicanálise didáctica; *Span.:* psicoanálisis didáctico.

**transcultural**

*Fr.:* transculturel; *Ger.:* transkulturell; *It.:* transculturale; *Port.:* transcultural; *Span.:* transcultural.

**trance**

*Fr.:* transe, trance; *Ger.:* Trance; *It.:* trance; *Port.:* transe; *Span.:* trance.

**transference**

*Fr.:* transfert; *Ger.:* Übertragung; *It.:* transfert; *Port.:* transferência; *Span.:* transferencia.

**transference depression**

*Fr.:* dépression de transfert; *Ger.:* Übertragungsdepression; *It.:* depressione di transfert; *Port.:* depressão de transferência; *Span.:* depresión de transferencia.

**transference love**

*Fr.:* transfert (amour de -); *Ger.:* Übertragungsliebe; *It.:* amore di transfert; *Port.:* amor de transferência; *Span.:* amor de transferencia.

**transference hatred**

*Fr.:* transfert (haine de -); *Ger.:* Hassübertragung/Übertragung (des Hasses); *Span.:* odio de transferencia; *It.:* odio di transfert; *Port.:* ódio de transferência.

**transference neurosis**

*Fr.:* transfert (névrose de -); *Ger.:* Übertragungsneurose; *It.:* nevrosi di transfert; *Port.:* neurose de transferência; *Span.:* neurosis de transferencia.

**transference of creativity**

*Fr.:* transfert de créativité; *Ger.:* Übertragung der Kreativität; *It.:* transfert di creatività; *Port.:* transferência de criatividade; *Span.:* transferencia de creatividad.

**transference relationship**

*Fr.:* transférentielle (relation -); *Ger.:* Übertragungsbeziehung; *It.:* relazione di transfert; *Port.:* relação transferencial; *Span.:* relación transferencial.

**transformation**

*Fr.:* transformation; *Ger.:* Verwandlung; *It.:* trasformazione; *Port.:* transformação; *Span.:* transformación.

**transgression**

*Fr.:* transgression; *Ger.:* Übertretung; *It.:* trasgressione; *Port.:* transgressão; *Span.:* transgresión.

**transitional object**

*Fr.:* objet transitionnel; *Ger.:* Übergangsobjekt; *It.:* oggetto transizionale; *Port.:* objecto transicional; *Span.:* objeto transicional.

**transitional object, space**

*Fr.*: transitionnel (objet transitionnel, aire transitionnelle); *Ger.*: Übergangsobjekt, Übergangsraum; *It.*: oggetto transizionale, area transizionale; *Port.*: objecto transicional, área transicional; *Span.*: transicional (objeto transicional, campo transicional).

**transitional phenomenon**

*Fr.*: phénomène transitionnel; *Ger.*: Übergangspänomen; *It.*: fenomeno transizionale; *Port.*: fenômeno transicional; *Span.*: fenómeno transicional.

**translation**

*Fr.*: traduction; *Ger.*: Übersetzung; *It.*: traduzione; *Port.*: tradução; *Span.*: traducción.

**transmuting internalization**

*Fr.*: intériorisation mutative; *Ger.*: verwandelnde Internalisierung; *It.*: interiorizzazione trasmutante; *Port.*: interiorização mutativa; *Span.*: interiorización mutativa.

**transsexualism**

*Fr.*: transsexualisme; *Ger.*: Transsexualismus; *It.*: transesualismo; *Port.*: transsexualismo; *Span.*: transexualismo.

**trauma**

*Fr.*: traumatisme; *Ger.*: Trauma; *It.*: trauma; *Port.*: traumatismo; *Span.*: traumatismo.

**traumatic neurosis**

*Fr.*: traumatique (névrose -); *Ger.*: traumatische Neurose; *It.*: nevrosi traumatica; *Port.*: neurose traumática; *Span.*: neurosis traumática.

**truth**

*Fr.*: vérité; *Ger.*: Wahrheit; *It.*: verità; *Port.*: verdade; *Span.*: verdad.

**turning around**

*Fr.*: retournement; *Ger.*: Wendung; *It.*: capovolgimento; *Port.*: voltar; *Span.*: vuelta.

**turning around upon the subject's own self**

*Fr.*: retournement sur la personne propre; *Ger.*: Wendung gegen die eigene Person; *It.*: capovolgimento sulla propria persona; *Port.*: voltar contra si mesmo; *Span.*: vuelta en contra del sujeto.

**twinship transference, alter ego transference**

*Fr.*: transfert en jumelage (transfert à l'alter ego); *Ger.*: Zwillingübertragung, Alter ego-Übertragung; *It.*: transfert gemellare o di alter ego; *Port.*: transferência gemelar; *Span.*: transferencia gemelar (transferencia al alter ego).

**typical dream**

*Fr.*: rêve typique; *Ger.*: typischer Traum; *It.*: sogno tipico; *Port.*: sonho típico; *Span.*: sueño típico.

**ulcerative colitis**

*Fr.*: recto-colite hémorragique; *Ger.*: hämorrhagische Rektokolitis; *It.*: rettocolite ulcerosa; *Port.*: rectolite hemorrágica; *Span.*: rectocolitis hemorrágica.

**unary trait**

*Fr.*: trait unaire; *Ger.*: einziger Zug; *It.*: tratto unario; *Port.*: traço unário; *Span.*: trazo unario.

**unconscious concept**

*Fr.*: concept inconscient; *Ger.*: Konzept vom Unbewussten; *It.*: concetto inconscio; *Port.*: conceito inconsciente; *Span.*: concepto inconsciente.

**unconscious fantasy**

*Fr.*: phantasme inconscient; *Ger.*: unbewusste Phantasie; *It.*: fantasia inconscia/fantasma inconscio; *Port.*: fantasia inconsciente; *Span.*: fantasía inconsciente.

**Unconscious, the**

*Fr.*: Inconscient; *Ger.*: Unbewusste; *It.*: Inconscio; *Port.*: Inconsciente; *Span.*: Inconsciente.

**undoing**

*Fr.*: annulation rétroactive; *Ger.*: Ungeschehenmachen; *It.*: annullamento retroattivo; *Port.*: anulação retroactiva; *Span.*: anulación retroactiva/neutralización.

**unpleasure**

*Fr.*: déplaisir; *Ger.*: Unlust; *It.*: dispiacere; *Port.*: desprazer; *Span.*: displacer.

**unvalidated unconscious**

*Fr.*: inconscient invalidé; *Ger.*: ungewichtetes Unbewusstes; *It.*: inconscio non convalidato; *Port.*: inconsciente invalidado; *Span.*: inconsciente invalidado.

**urethral eroticism**

*Fr.*: érotisme urétral; *Ger.*: Urethralerotik/Harnerotik; *It.*: erotismo uretrale; *Port.*: erotismo uretral; *Span.*: erotismo uretral.

**“vagina dentata,” fantasy of**

*Fr.*: fantasme du vagin denté; *Ger.*: Phantasie von einer vagina dentata; *It.*: fantasia della vagina dentata; *Port.*: fantasia da vagina dentata; *Span.*: fantasía de la vagina dentada.

**vertex**

*Fr.*: vertex; *Ger.*: “vertex”; *It.*: vertice; *Port.*: vértice; *Span.*: vértice.

**vertical and horizontal splitting**

*Fr.*: clivage vertical et horizontal; *Ger.*: vertikale und horizontale Spaltung; *It.*: scissione verticale e orizzontale; *Port.*: clivagem vertical e horizontal; *Span.*: escisión vertical y horizontal.

**violence, instinct for**

*Fr.*: violence (instinct de -); *Ger.*: Gewaltinstinkt; *It.*: istinto di violenza; *Port.*: impulso de violência; *Span.*: instinto de violencia.

**visual**

*Fr.*: visuel; *Ger.*: visuell; *It.*: visivo; *Port.*: visual; *Span.*: visual.

**voyeurism**

*Fr.*: voyeurisme; *Ger.*: Voyeurismus; *It.*: voyeurismo; *Port.*: voyeurismo; *Span.*: voyeurismo.

**want of being/lack of being**

*Fr.*: manque-à-être; *Ger.*: Fehlen-an-Sein; *It.*: mancanza ad essere; *Port.*: falta-a-ser; *Span.*: déficit de ser/falta de ser.

**war neurosis**

*Fr.*: névrose de guerre; *Ger.*: Kriegsneurose; *It.*: nevrosi di guerra; *Port.*: neurose de guerra; *Span.*: neurosis de guerra.

**weaning**

*Fr.*: sevrage; *Ger.*: Entwöhnung *It.*: svezzamento; *Port.*: desmame; *Span.*: destete.

**wish**

*Fr.*: vœu (souhait); *Ger.*: Wunsch; *It.*: desiderio (voto, auspicio); *Port.*: votos-desejo; *Span.*: deseo (augurio).

**wish for a baby**

*Fr.*: désir d'enfant; *Ger.*: Kinderwunsch; *It.*: desiderio di un bambino; *Port.*: desejo de um filho; *Span.*: deseo de un niño.

**wish-fulfillment**

*Fr.*: désir (accomplissement du -); *Ger.*: Wunscherfüllung; *It.*: appagamento di desiderio; *Port.*: realização de desejo; *Span.*: realización de deseo.

**wish, hallucinatory satisfaction of a**

*Fr.*: désir (satisfaction hallucinatoire du -); *Ger.*: halluzinatorische Wunscherfüllung; *It.*: appagamento allu-

cinatorio del desiderio; *Port.*: satisfação alucinatória do desejo; *Span.*: satisfacción alucinatória de deseo.

**wish/yearning**

*Fr.*: désir (ou désirance); *Ger.*: Wunsch, Begehren; *It.*: desiderio; *Port.*: desejo; *Span.*: deseo.

**word association**

*Fr.*: association de mots; *Ger.*: Wortassoziation; *It.*: associazione di parole; *Port.*: associação de palavras; *Span.*: asociación de palabras.

**word-presentation**

*Fr.*: représentation de mot; *Ger.*: Wortvorstellung; *It.*: rappresentazione di parola; *Port.*: representação de palavra; *Span.*: representación de palabra.

**work**

*Fr.*: travail; *Ger.*: Arbeit; *It.*: lavoro; *Port.*: trabalho; *Span.*: trabajo.

**work of mourning**

*Fr.*: travail de deuil; *Ger.*: Trauerarbeit; *It.*: lavoro del lutto; *Port.*: trabalho do luto; *Span.*: trabajo de duelo.

**working-off mechanisms**

*Fr.*: dégageant (mécanismes de -); *Ger.*: Abarbeitungsmechanismen; *It.*: meccanismi di disimpegno; *Port.*: mecanismos de desimpedimento; *Span.*: mecanismos de desprendimiento.

**working over**

*Fr.*: élaboration psychique; *Ger.*: psychische Verarbeitung/psychische Bearbeitung/psychische Ausarbeitung/psychische Aufarbeitung; *It.*: elaborazione psichica; *Port.*: elaboração psíquica; *Span.*: elaboración psíquica.

**working-through**

*Fr.*: perlaboration; *Ger.*: Durcharbeiten; *It.*: rielaborazione; *Port.*: perlaboração; *Span.*: trabajo elaborativo.



# ACKNOWLEDGEMENTS FROM THE FRENCH EDITION

## ACKNOWLEDGEMENTS FROM THE FRENCH EDITION

I am indebted to Michel Prigent for giving me the idea to take part in this project to create a *Dictionary of Psychoanalysis*, as well as for giving me responsibility for its History Section. Although it was his wish to add this *Dictionary* to the diverse catalog published by Presses Universitaires de France; the vagaries of a collaboration that was difficult to establish and maintain based on divergent conceptual underpinnings led me in the end to submit on my own the very different project which these volumes represent to Éditions Calman-Levy in March 1995.

Encouraged and pursued by Isabelle Seguin until 1998, its principle form was accepted by Jean-Étienne Cohen-Séat who was the project's director at that time. After his departure Olivier Nora and Denis Bourgeois assumed responsibility for reworking it, with the assistance of Olivier Amiel after 1998. Finally Jean-Étienne Cohen-Séat closed the loop on its publication, or rather on its development into its final form after a relatively stagnant period in terms of editing. I am indeed particularly grateful to Marc Grinsztajn for his material support (to which Marie Donnet equally contributed), as well as for the moral backing he provided during the final months of this saga.

As soon as Cécile Nail became involved in the project in 2000, she was entrusted with the task of completing a critical re-reading of all the dictionary's entries, and the questions she raised led me to revisit each of the texts one by one once more, on top of the debates raised by a previous reader who was well-educated but not particularly a specialist in psychoanalysis. Besides the inevitable errors that were thereby unearthed, this work corrected certain contradictions and highly-impediment ambiguities, as well as numerous naiveties and tics in the "language" of psychoanalysis itself. Although some of these still remain, this work pruned them down vigilantly.

All this added to the timeline and entailed supplemental investments. I can not say enough times that Éditions Camann-Lévy undertook considerable financial risk by not giving up on the development of an original and voluminous work, comprising numerous translations and which paid a decent honorarium to each of its authors, all without external support, including even any reliance on the Centre National du Livre in 2001, and all this whilst their Human Sciences Division was undergoing a severe fiscal crisis. I owe them an immense personal debt of gratitude, just as I can never forget the choice Jean-Étienne Cohen-Séat made upon his return as Director in the Spring of 2000 to make the necessary sacrifices in order that the *Dictionary's* publication be continued, and that its production be as impeccable as possible.

I have never been alone in this enterprise, and I am also grateful for the adept and never-ending support provided by all the members of this sound and venerable publishing



house. They all helped me get the project off the ground and saw to its completion, but in particular I should like to mention Élisabeth Laye and Rosa Thieck, without forgetting Claire Teuwissen and Heidi Warnecke, who worked to get foreign publishers to get started on publishing this work, as well as Bernard Dobremetz and above all Bénédicte Gerber, (who invested the most faithfully of all in this work throughout all these long years, and who was my most reliable supporter), who saw to the delicate tasks of executing its actual production.

Catherine Joubaud and Éliane Rosenberg-Mounier must also be singled-out. It was their mission to “set up” the final manuscript, meaning to read all the entries a first time through after I had finished re-reading them, in order to standardize the formats, which had changed a bit over the years, and also to identify and correct stylistic and spelling errors, as well as other incoherencies which had managed to escape our previous readings—all this in addition to revising the 3,200 bibliographic references. I must also thank Jacques Sédat for the revisions he was kind enough to undertake of the proofs. *Last but not least*, Catherine Picard and Catherine Schram effected a final critical revision of all the proofs which was particularly painstaking and once again came on the heels of my own reading.

The translators were either longtime friends like Ruth Menahem, or highly-qualified professionals like Pierre-Emmanuel Duzat who had contributed some of the edition’s finest gems, like *History of Psychoanalysis* (at the Presses Universitaires de France), Dominique Lepreux, Alix Gaillard-Dermigny who, with Martine Sandor-Buthaud, assumed responsibility for all the Analytic Psychology articles, and finally Danielle Goldstein and Catherine Wieder. Other friends and colleagues contributed to the constitution of the glossary which includes the translation of a large number of concepts into five different languages: Dr. Pedro Luzes and M. Norton Godinho from the Portuguese, Dr. Roberto Goldstein and Mrs. Béatrice Marquis-Goldstein from the Spanish, Dr. Gian Franco Nicolussi and Dr. Alberto Luchetti from the Italian, Mr. Andrew Weller from the English, and Andrew Weller and Mrs. Vera Renz from the German.

It is true that 20 years of work as an editor allowed me to draw upon a wealth of friends who greatly contributed to completing a work in seven years that should have called for even more time. First of all I must thank those amongst my colleagues who spontaneously agreed to encourage this project by supporting it in various forms from the first moment it was announced. Their encouragement touched me deeply and I viewed it as a mark of confidence that was accorded to me even though everything still remained to be done. Their list is long and certain amongst them will no longer be with us at the time the book to which they attached their immediate confidence appears, but it is my duty to remember their names: Mr. André Alsteens (Belgium), Dr. Jacqueline Amati-Mehler (Italy), Professor Didier-Anzieu (France), Dr. Harold Blum (United States), Professor René Diatkine (France), Dr. Roger A. Dufresne (Canada), Dr. Horacio Etchegoyen (Argentina), Dr. Ernst Federn (Austria), Professor Gerhard Fichtner (Germany), Dr. Olivier Flournoy (Switzerland), Dr.-Professor Folch Mateu (Spain), Dr. Peter Fonagy (United Kingdom), Dr. André Green (France), Dr. León Grinberg (Spain), Mrs. Han Groen-Prakken (Netherlands), Professor André Haynal (Switzerland), Dr. Otto F. Kernberg (United States), Miss Pearl King (United Kingdom), Professor Georges Lantéri-Laura (France), Professor Serge Lebovici (France), Dr. Harald Leupold-Löwenthal (Austria), Professor Peter Loewenberg (United States), Ft/ Pedro Luzes (Portugal), Mr. Patrick Mahony (Canada), Mrs. Joyce MacDougall (France), Dr. Keigo Okonogi (Japan), Mrs. Anna Potamianou (Greece), Dr. Jean-Michel Quinodoz (Switzerland), Professor Álvaro Rey de Castro (Peru), Mrs. Anne-Marie Sandler (United Kingdom), Professor Joseph Sandler (United Kingdom), Dr. Antonio Santamaria Fernandez (Mexico), Professor Jacques Schotte (Belgium), Mr. Riccardo Steiner (United

Kingdom), Dr. Jean-Paul Valabrega (France), Dr. Robert Wallerstein (United States), Professor Daniel Widlocher (France) and Mrs. Nathalie Zaltzmann (France).

At practically the same moment in time, a certain number of other associates were asked for their scientific advice concerning the choice of entries and authors in the areas where they excelled the most. I shall recall them here more precisely by including their privileged domains: Anna Maria Accerboni and Giancarlo Gramaglia advised us concerning entries related to Italy; Jorge Luis Ahumada for Argentina, André Alsteens for Belgium, Mireille Cifali and Bernard Minder for Switzerland, Judith Dupont for Hungary, Horacio Etchegoyen for South America, Han Groen-Prakken for the Netherlands, Ludger M. Hermanns for Germany, Robert D. Hinshelwood and Riccardo Steiner for the United Kingdom, Didier Houzel for the entries on Wilfred R. Bion, Per Magnus Johansson for the Scandinavian countries, Thomas Kirsch and Christian Gaillard for Psychoanalytic Psychology, Maria Luisa Munoz for Spain, Ingrid Scholz-Strasse for Austria, Agnès Oppenheimer for Heinz Kohut, Bernard Pernot, Marie-Christine Laznik and Jacques Sédât for the entries on Lacanian psychoanalysis, Jean-François Rabain for Japan, Joseph Reppen and Paul Roazen for the United States.

I believe I sufficiently emphasized the use of the word “we” in my introductory comments to this *Dictionary* for it to be understood how indebted I have been to the members of the editorial committee for their scientific contributions and undying support. Whether it was a question of the initial choice between which articles to include and authors to use, or of assuming responsibility for writing a large number of articles and therefore taking up the slack when one or another of the former fell short, the following were in various guises the artisans of a work that without them would not exist: Sophie de Mijolla-Mellor (for writing of 96 entries and managing 165), Roger Perron (for writing 83 entries and managing 254), and Bernard Golse (for writing 40 articles and managing 194); all of whom were helped in the beginning by Jacques Angelergues. Affection, friendship and gratitude combined with the talents each of these colleagues possess resulted in a collaborative effort that rendered the management of the project far easier than I could have ever hoped for.

All that remains are the principal artisans of the work: that is the 460 authors who combined forces from all four corners of the globe into an enterprise upon which they bestowed us the pleasure and the honor of believing in, and therefore of being able to invest ourselves in, usually with great passion. Though some will never see the results of their efforts, including: André Alsteens, Didier Anzieu, Parthenope Bion Talamo, Owen Hugh D. Blomfield, Simone Decombert, Joël Dor, Serge Lebovici, Rosario Merendino, Marie-Thérèse Neyraut-Sutterman, Agnès Oppenheimer, Augusto Miguel Picollo, Helene Rank-Veltfort, Joël Sipsos and Maria Torrok; their presence remains alive and well in the texts they have written.

I do not want to close this all too brief list of acknowledgements, given the many supporters and friends I must have forgotten, without highlighting our debt to the work completed by our British and American colleagues in the development of their indispensable tool, the “P.E.P. Archives CD-ROM,” which groups together the totality of articles published by the primary English-language psychoanalytic journals from their inception dates through today. Much fact checking and supplemental information were made possible thanks this resolutely modern instrument of research.

However we shouldn’t let this homage fool us! It is mixed with equal parts envy and regret that we have not yet been able to complete a similar compendium of the French-language psychoanalytic literature. Let it express nonetheless the hope that our *Dictionary* may itself now become usable and susceptible to being regularly updated by future means of diffusion and search-engines that this 21st century, which has spawned it, has yet to develop.

ALAIN DE MIJOLLA



# INDEX

## INDEX

Page links created automatically - disregard ones not formed from page numbers

Page numbers in **boldface** indicate main entry on subject. Locations of insert photographs are indicated in the following manner: "I:pl. 1," where I is the volume number, and pl. 1 is the plate number as indicated in the insert. The inserts can be found after p. 238 in Vol. I, after p. 998 in Vol. II, and after p. 1722 in Vol. 3.

### A

- A la recherche du temps perdu* (Proust), 986  
 "À l'aise dans la civilization" (Pichon), 1283  
 "À l'écoute du télescopage des générations" (Faimberg), 846  
*À partir de Freud* (Pasche), 1242  
 "À propos de la mythomania" (Neyraut), 1098  
*À propos de la relation érotomaniaque* (Kestemberg), 912  
 "À propos de trois cas d'anorexie mentale" (Laurent-Lucas-Championnière-Maugé), 948–949  
 "À quoi reconnaît-on le structuralisme?" (Deleuze), 1668  
 "A. Z.," 1  
 AÄGP (Allgemeine Ärztliche Gesellschaft für Psychotherapie) (General Medical Society for Psychotherapy), **49**, 1131, 1547  
 Abadi, Mauricio, 118  
 Abandonment, **1–3**, 101, 394–395, 715  
 Abed, Mohamed, 1155  
 Abel, Carl, **3–4**, 981, 1495  
 Abel, Karl, 1585  
 Abello, Nuria, 933  
 Abelló, Nuria, 1637  
 Aberastury, Arminda ("La Negra"), **4–5**, 55, 117, 217, 1015  
 Aberastury, Federico, 117  
 Ablation, 1521  
 ABP (Associação Brasileira de Psicanálise), 215  
 Abraham, Georges, 1701  
 Abraham, Hilda, 5  
 Abraham, Karl, **5–6**, 638  
   on addiction, 23  
   on alcoholism, 41  
   on ambivalence, 6, 56–57, 74, 326, 394, 1082, 1204–1205  
   on anal eroticism, 514, 515  
   on anal-sadistic stage, 74  
   on anality, 72  
   on applied psychoanalysis, 108  
 Benedek and, 159  
 Berliner Psychoanalytische Poliklinik and, 164, 675  
 Berliner Psychoanalytisches Institut and, 5, 6, 165  
   on birth dreams, 186  
 Boehm and, 5, 198  
 Brazilian psychoanalysis and, 217  
 British Psycho-Analytical Society and, 228  
   on bulimia, 233  
 Burghölzli Asylum and, 180, 236  
   on castration complex, 1676  
   on character, 270, 272  
   child analysis and, 1731  
   on choice of neurosis, 288  
 cinema and, 293  
   on coprophilia, 346  
   on depression, 394  
*Development of Psycho-Analysis* and, 581  
   on dreams, 443  
 Eder and, 460  
 Eitingon and, 493  
 First World War and, 585  
 Freud, Ernst and, 622  
 Freud-Jung split and, 1200  
 German psychoanalysis and, 674  
   on gifts, 682  
 Glover, Edward and, 5, 684  
 Glover, James and, 5, 684, 685  
 Hartmann and, 727  
 Hogarth Press and, 753  
   on imposter, 803  
   on incorporation, 1105  
   on indications/contraindications for psychoanalysis, 809  
   on internal objects, 395, 396, 849  
 International Psychoanalytical Association and, 854  
*Internationale Zeitschrift für Psychoanalyse* and, 860  
   on introjection, 6, 869  
*Jahrbuch der Psychoanalyse* and, 884  
*Jahrbuch für psychoanalytische und psychopathologische Forschungen* and, 884  
 Jury and, 904  
 Klein and, 5, 914  
   on libidinal development, 5–6, 38, 56–57, 966, 967, 1038  
   on libido, 968, 969  
   on lies, 972  
 Mahler-Schönberger and, 1001  
   on mania, 1006, 1007  
   on melancholia, 6, 1037, 1038, 1039, 1082  
 Müller-Braunschweig and, 1085  
   on mythology, 443, 1099  
   on narcissism, 1106  
   on narcissistic neuroses, 1114  
   on object, 1169  
   object *a* and, 1173  
   on object loss, 994  
   on oral eroticism, 516  
   on oral-sadistic stage, 6, 1038, 1082, 1114, 1203  
   on oral stage, 6, 57, 516, 1203, 1204–1205

## INDEX

Volume 1, pp. 1–662; Volume 2, pp. 663–1344; Volume 3, pp. 1345–1892

- on orality, 1202  
 on organization, 1208  
 on paranoia, 1230  
 on part-objects, 1649  
 on partial drives, 1241  
 on payment for treatment, 1069  
 on phallic mother, 1261, 1263  
 photographs of, I:pl.1, III:pl.9  
 on psychoanalytic treatment, 1729  
 on psychoses, 21, 1404  
 on psychosexual development, 1406  
 on psychosis/neurosis distinction, 1415  
 Reik and, 5, 1462, 1463  
 on religion, 899  
*Revista de psiquiatría y disciplinas conexas* and, 1497  
 Russian/Soviet psychoanalysis and, 1518  
 on sadism, 1022, 1526  
 on schizophrenia, 6, 1540  
 Schmidt, Vera and, 1544  
 on Schreber case, 1546  
 Secret Committee and, 5, 1561  
*Secrets of a Soul, The* and, 1562, 1563  
 on silence, 1610  
 Simmel and, 5, 6, 1611  
 Strachey-Sargent and, 1664  
 on sucking, 1682  
 Swiss psychoanalysis and, 1702  
 on tics, 1756  
 on trauma, 1801  
 on urethral eroticism, 517  
 on “vagina dentata” fantasy, 1831  
 on violence, 34  
 on visual arts, 1841  
 on war neuroses, 1848  
 on whole-object love, 218  
 Wulff and, 1881
- Abraham, Nicolas, **6–7**  
*Confrontation* and, 327  
 on cultural transmission, 358  
 on intergenerational phenomena, 846  
 on introjection, 870  
 on phantom, 1265–1266  
 on secrets, 1560  
 Torok and, 6, 1764–1765
- Abreaction  
 cathartic method and, 258, 1670  
 cinema on, 1562, 1563  
 constancy principle and, 1322  
 discharge and, 418  
 lifting of amnesia and, 976, 977  
 lifting of repression and, 1486  
 memories and, 1041  
 neurotic defenses and, 1141
- Absence, 99, 1121, 1122, 1749–1750  
 Abstinence, **7–8**, 11, 1385, 1786  
 Absurdity, 1584  
 Accerboni, Anna Maria, 881  
 Acevedo de Mendilaharsu, Sélika, 1829  
 Achard, Laura, 1829  
 Acheson, Dean, 1087  
 Achté, Kalle, 584  
 “Acquisition and Control of Fire, The” (Freud), 107, 299, 348, 517, 1367–1368
- Act/action, **9–10**  
 abstinence and, 7  
 adolescence and, 27  
 fantasy and, 9, 552–553  
 passage to the act, 10, 18–19, 1390  
*See also* Thought vs. action
- Acting in, **10**  
 Acting out, **10–11**  
 action-presentations and, 13  
 alcoholism and, 41  
 change and, 267  
 discharge and, 10, 418  
 “Dora” case and, 10, 605  
 fundamental rule and, 657  
 passage to the act and, 10, 18  
 termination of treatment and, 1737  
 transference and, 10, 11, 657, 1786
- Action. *See* Act/action
- Action-language, **11–12**, 13  
 Action-presentations, **12–13**  
 Action-representations. *See* Action-presentations
- Action-thought, **9**, **13–14**  
 Active analysis, 1657  
 Active imagination, **14–15**, 67  
 Active technique, **15–16**, 581, 1729  
 abstinence and, 8  
*Development of Psycho-Analysis* and, 407  
 frame of psychoanalytic treatment and, 607  
 Freud on, 15, 16, 640  
 Kovács-Prosznitz on, 923
- Activity/passivity, **16–18**  
 anality and, 72  
 female sexuality and, 570–571  
 feminist views of psychoanalysis and, 576  
 masculinity/femininity and, 16, 17, 576, 1020  
 sadism/masochism and, 17, 1021  
 “Actor’s Complex, The” (Guilbert), 715
- Actual neuroses, **19–20**, 231, 326, 345, 420, 1138–1139
- Acuña, Fernando, 1832  
 Acute psychoses, **21–22**  
 Adami, Valério, 240  
 Adamov, Jacqueline, 1499  
 Adaptation, **22–23**  
 complexes and, 321  
 ego and, 375, 475, 488  
 introjection and, 870  
 Loewenstein on, 989  
 war neuroses and, 907  
 “Adaptation, Individuation and Collectivity” (Jung), 811
- Addiction, **23–24**  
 alcoholism, 40–42  
 alienation and, 44  
 anorexia nervosa and, 92  
 Brunswick and, 232  
 bulimia and, 233  
 cocaine and, 308  
 dependence and, 392  
 narcissistic neuroses and, 1114
- Adelman, Janet, 1598  
 Adhesive identification, **24–25**  
 asthma and, 125  
 autism and, 24, 137  
 dismantling and, 419  
 infant development and, 815  
 object and, 1170
- Adler, Alfred, **25–26**  
 on aggression, 33  
 on anxiety neurosis, 1137  
 Baudouin and, 154, 155  
 on belief, 159  
 Bjerre and, 188  
 Brazilian psychoanalysis and, 217  
 child analysis and, 279  
 on compulsion, 323  
 definition of psychoanalysis and, 1363  
 Delgado and, 385  
 on ego, 462–463  
 Ellenberger on, 497  
 on erythrophobia, 522  
 extroversion/introversion and, 538  
 Freud and, 25, 639, 1643  
 on fusion/defusion, 659  
 Greek psychoanalysis and, 701  
 Hall and, 721  
 Hilferding-Hönigsberg and, 746  
 on inferiority feelings, 831–832  
*Jahrbuch der Psychoanalyse* and, 884  
 Jelliffe and, 1379  
 Jung and, 902

Volume 1, pp. 1–662; Volume 2, pp. 663–1344; Volume 3, pp. 1345–1892

- on masculine protest, 252, 575, 1018–1019, 1105, 1110, 1246  
monism/dualism and, 1070, 1071  
“On the History of the Psychoanalytic Movement” and, 1192  
photograph of, I:pl.2  
on politics, 1293  
*Psyche* and, 1351  
*Psychotherapia* and, 1411  
Rank and, 1444  
*Sigmund Freud: Life and Work* on, 973  
on social feeling, 1617–1618  
Swedish psychoanalysis and, 1697  
Wiener psychoanalytische Vereinigung and, 132, 854, 1857  
*See also* Individual psychology
- Adler, Gerhard, 79, 80
- Adolescence, **26–28**  
aggression and, 26, 35  
Blos on, 28, 196–197  
bulimia and, 234  
dependence and, 392  
heroic self and, 740  
Mâle on, 1004  
midlife crisis and, 30, 1055  
passage to the act in, 19  
pleasure ego/reality ego and, 1288  
self-mutilation and, 1572  
self-representation and, 1578  
suicide and, 1686  
superego and, 1691
- Adolescent crisis, 27, **28–30**
- Adorno, Theodor, **30–32**, 1632  
Foulkes and, 601  
German psychoanalysis and, 675, 677  
Institute for Social Research and, 1013  
Marxism and, 31, 1018
- Aeschylus, 574, 922
- Aesthetic conflict, 137
- “Aetiology of Hysteria, The” (Freud)  
on defense mechanisms, 376  
on lifting of amnesia, 976  
on memories, 1040  
on mnemonic symbols, 1061, 1062  
on mnemonic traces, 1064  
on seduction theory, 1755  
Stekel and, 1657
- Affect  
abandonment and, 2  
cathexis and, 259  
deprivation and, 397  
emotions and, 501  
hysterical paralysis and, 774  
identification with the aggressor and, 792  
memories and, 1040, 1041  
music and, 1088–1089  
neurotic defenses and, 1142  
object relations theory and, 1176–1177  
primary object and, 1317  
quantitative/qualitative dimensions of, 1427–1428  
quota of, 786, 1428, 1433–1434, 1875  
representation and, 781, 1477–1478  
repression and, 1482–1483  
reversal into the opposite and, 1495  
suppression and, 1693  
unpleasure and, 1826  
work and, 1875  
working-through and, 1880  
*See also* Emotions; Pleasure principle
- Affectionate current, 56
- Affective attunement, 454, 867
- “Affects in Theory and Practise” (Brierley), 226
- Affranchissement*, 241
- Afterwardsness. *See* Deferred action
- Agency, **32–33**  
“Aggressivité et fantasmes d’agression” (Diatkine), 411
- Aggression, **33–35**  
adolescence and, 26, 35  
allergies and, 48  
anaclitic depression and, 70  
anxiety and, 100, 101  
“as if” personality and, 122  
Bak on, 147  
conflict and, 326  
criminology and, 354  
cruelty and, 355  
death instinct and, 372  
depression and, 394  
depressive position and, 395, 396  
envy and, 508–509  
feminine masochism and, 572  
Greenacre on, 702  
guilt and, 716  
mastery and, 1024  
object relations theory and, 1176  
oral-sadistic stage and, 1203  
paranoid position and, 1231  
phobia of impulsive acts and, 1272  
sodomasochism and, 1527  
Schlumberger on, 1542  
self-mutilation and, 1573  
sublimation and, 1679  
vs. violence, 33–34  
“Aggression in Relation to Emotional Development” (Winnicott), 1581
- Agieren*. *See* Acting out
- Agoraphobia, 306
- Agorio, Roberto, 1828, 1829
- Agrachev, Sergei, 1520
- Aha-Erlebnis*, 1569
- Aichhorn, August, **35–36**  
on abandonment, 2  
Austrian psychoanalysis and, 133  
Blos and, 196  
boundary violations and, 209  
Caruso and, 248  
Czech psychoanalysis and, 361  
Eissler and, 490  
Göring and, 689  
Hietzing Schule and, 745  
Kohut and, 919  
Lehrinstitut der Wiener psychoanalytischen Vereinigung and, 959  
Mahler-Schönberger and, 1001  
Nazi Germany and, 1858, 1863  
Ross and, 1516  
Sterba-Radanowicz-Hartmann, Editha and, 1658  
Swedish psychoanalysis and, 1698  
Vienna Ambulatorium and, 959  
Wiener psychoanalytische Vereinigung and, 1857, 1858  
*Zeitschrift für psychoanalytische Pädagogik* and, 1886
- Aigrisse, Gilberte, 158
- “Ailment, The” (Main), 1003
- “Aimée” case, **36–39**, 104
- Aims, 534
- Ainsworth, Mary  
on anaclitic depression, 70  
on attachment, 125, 815, 822, 1030  
on hospitalism, 760  
on maternal care, 1029  
on puerperal psychoses, 1422  
on strange situation, 125, 822  
Tavistock Clinic and, 1728
- Aisenstein, Marilia, 1460, 1630, 1631
- Aíza, Victor, 566, 1051, 1052
- Ajase complex, **39–40**, 319, 887, 888, 922
- Ajuriaguerra, Julian de  
Diatkine and, 410  
on infant development, 814  
Lebovici and, 955  
on relaxation psychotherapy, 1465

## INDEX

Volume 1, pp. 1–662; Volume 2, pp. 663–1344; Volume 3, pp. 1345–1892

- Swiss psychoanalysis and, 1701  
 on tenderness, 1736
- Alajouanine, Théophile, 1283
- Alanen, Yrjö, 584
- Albiston, Norman, 131
- Albu, Enid. *See* Balint, Enid
- Alchemy, **40**, 115, 902, 1597, 1608
- Alcohol consumption, 1585
- Alcoholism, **40–42**, 412–413
- Alexander, Franz Gabriel, **42–43**  
 on allergies, 47
- American Academy of Psychoanalysis and,  
 43, 58  
 on asthma, 124, 125
- Benedek and, 160
- Berliner Psychoanalytisches Institut and,  
 42, 166
- Bettelheim and, 173
- Boston Psychoanalytic Society/Institute  
 and, 207  
 on character, 272
- Chicago Psychoanalytic Institute and,  
 277–278, 919, 1823
- Congrès mondial de psychiatrie and, 539  
 on dependence, 392
- Freud, Oliver and, 631
- German psychoanalysis and, 1060  
 on group analysis, 601
- Heimann and, 730
- Hungarian School and, 764
- International Federation of Psychoanalytic  
 Societies and, 852
- Kardiner and, 906
- Kris-Rie and, 925
- Murray and, 1087
- neopsychoanalysis and, 1131
- photograph of, I:pl.3  
 on psychic causality, 1354  
 on psychosomatics, 43, 208, 1408–1409
- Radó and, 1441
- Rank and, 1445
- Rivista di psicoanalisi* and, 1508
- Ross and, 1516
- Sachs and, 42, 1523
- Saussure, Raymond de and, 1536
- Southern California Psychoanalytic  
 Society/Institute and, 992, 993
- Tegel clinic and, 1734  
 on termination of treatment, 1738
- Weiss and, 1854
- Alexander, Irving, 1396
- Alexandris, Athena, 701
- Alexithymia, 18, 41, 523
- Alfred Binet Center. *See* Centre Alfred-Binet
- Algerian psychoanalysis, 1155
- Alienation, **43–45**  
 Althusser on, 53
- Aulagnier-Spairani on, 44, 111
- certainty and, 265
- ego ideal and, 44, 480
- fourth analysis and, 603
- I* and, 775
- ideology and, 795–796
- imaginary and, 799
- lack of being and, 1848
- passion and, 1243
- sudden involuntary ideas and, 1683
- symptom-formation and, 1717
- Alimentary orgasm, 413
- Allen, Frederick, 1445
- Allen, Woody, 47, 292, 294, 1365
- Allende Navarro, Fernando, 284, 1033
- Allendy, René Félix Eugène, **45–47**  
 Borel and, 204
- Claude and, 46, 305, 1345–1346
- Congrès des psychanalystes de langue  
 française des pays romans and, 329–330
- Disque vert, Le* and, 423, 424
- Ey and, 539
- French psychoanalysis and, 607–608
- Journal d'un médecin malade*, 46, 896–897
- Laforge and, 46, 934
- Nin and, 46, 1150
- Psychanalyse et les névroses, La*, 46, 305,  
 934, 1345–1346
- Psyché* and, 1350
- Revue française de psychanalyse* and, 1498
- Société psychanalytique de Paris founding  
 and, 199, 1623, 1624
- surrealism and, 1696
- Allendy-Nel-Dumouchel, Yvonne, **45**, 46
- Allergic character, 48
- Allergic object relationship, **47**, 48
- Allergies, **47**, **47–49**
- Allgemeine Ärztliche Gesellschaft für  
 Psychotherapie (AÄGP), **49**, 1131, 1547
- Allgemeine Neurosenlehre* (Brun), 231
- Alloeroticism, 141
- Allouch, Jean, 1084
- Allport, Gordon William, 1567
- Almanach der Psychoanalyse*, **49–50**
- Almásy, Endre, 766
- Alpha-elements, **50–51**, 184  
 beta-elements and, 50, 171
- contact-barrier and, 50, 340
- infant development and, 815
- proto-thoughts and, 1343
- Alpha function, **51–52**, 184, 952, 953  
 alpha-elements and, 50
- arrogance and, 121
- beta-elements and, 171
- beta-screens and, 171–172
- frame of psychoanalytic treatment and, 606
- hallucinoses and, 722
- proto-thoughts and, 1343
- Als, Heidelise, 1382
- Als ob* personality. *See* “As if” personality
- Altenberg, Peter, 732
- Alter ego, **52**, 185, 317
- Alter ego transference. *See* Twinship  
 transference
- Alteration of the ego, 76, **468–469**
- Alterity. *See* Otherness
- Althusser, Louis, **52–53**, 611, 1018, 1668
- Altounian, Jeanine, 846, 1439
- Altruism, **53–55**, 97, 1449
- Altruistic surrender, 54, 236
- Alvarez, B., 315
- Alvarez de Toledo, Luisa Augusta Rebeca  
 Gambier de, **55–56**, 117, 1015
- Alvim, Francisco, 1296, 1297
- Alvin, F., 1637
- Alyoshina, Julia, 1520
- Amae*, **56**, 888
- Amar, André, 1632
- Amaral, Ligia, 919
- Ambition, 517, 1679
- Ambivalence, **56–57**  
 Abraham, Karl on, 6, 56–57, 74, 326, 394,  
 1082, 1204–1205
- aggression and, 34
- anal eroticism and, 514–515
- anal-sadistic stage and, 74
- anality and, 72
- bisexuality and, 187
- biting and, 6
- contradiction and, 341
- cruelty and, 355
- death and, 370
- depression and, 57, 394
- doubt and, 435–436
- fusion/defusion and, 658
- gifts and, 683
- guilt and, 716
- infantile psychosis and, 825, 826
- maternal and, 1027
- melancholia and, 21, 57, 1038, 1082
- myth of origins and, 1321

Volume 1, pp. 1–662; Volume 2, pp. 663–1344; Volume 3, pp. 1345–1892

- need for causality and, 1119  
 oral-sadistic stage and, 1203, 1204–1205  
 orality and, 57, 1202  
 pairs of opposites and, 1220  
 paranoia and, 1228  
 reaction-formations and, 1449  
 rivalry and, 1506  
 symptoms and, 1715  
 taboo and, 1723–1724  
 turning around and, 1806  
 uncanny and, 1815  
 undoing and, 1822  
 weaning and, 1851–1852
- Amentia, 57–58**  
 “Amentia” (Meynert), 1054
- American Academy of Psychoanalysis, 43, 58, **58–60**, 852  
*American Handbook of Psychiatry*, 1541  
*American Imago*, **60**, 801, 803, 1523, 1859  
 American Institute for Psychoanalysis, 759, 1644  
 American Psychoanalytic Association (APA), **60–63**  
 American Academy of Psychoanalysis and, 58, 59  
 Brill and, 227, 1823  
 Burrow and, 237, 238  
 Canadian psychoanalysis and, 242, 243, 244  
 Freud U.S. visit and, 303, 1823  
 Hall and, 721  
 International Psychoanalytical Association and, 227–228, 856, 857, 858–859, 1531, 1644, 1824, 1825–1826  
*Journal of the American Psychoanalytic Association* and, 897–898  
 Klein and, 992, 993  
 Kohut and, 919  
 lay analysis and, 61, 62–63, 857, 858–859, 951, 1432, 1644, 1823  
 Loewenstein and, 988  
 Los Angeles Psychoanalytic Society/Institute and, 992, 993  
 Putnam and, 207, 227, 1425, 1823  
 Rank and, 1445  
 Russian/Soviet psychoanalysis and, 1519  
 San Francisco Psychoanalytic Society and Institute and, 1529, 1530–1532  
 Second World War and, 1558  
 Sterba-Radanowicz-Hartmann and, 1658  
 Wilbur and, 1860
- American Society for Group Psychotherapy and Psychodrama, 78  
 American Therapeutic Society, 207
- Amnesia, **63–66**  
 infantile, 64, 592, 819–820  
 lifting of, **976–977**  
 somnambulism and, 1636  
*Amour au travers de la haine, L’* (Dorey), 729  
 Amphimixia, **66–67**  
 Amplification, **67–68**, 79, 865  
 Amputation, 1682  
 Amsden, George, 192  
*An Autobiographical Study* (Freud), 1672  
 Anaclisis, **68–70**, 1191, 1663, 1682  
 attachment and, 126  
 erotogenicity and, 520, 521  
 myth of origins and, 1092  
 narcissism and, 1105  
 object-choice and, 1175  
 objects and and, 1168  
 orality and, 1202, 1204  
 primary need and, 1316  
 reciprocal paths of influence and, 1456  
 sucking and, 1682, 1752–1753  
 Anaclitic depression, **70–71**, 397, 760, 1641  
 Anagogical interpretation, **71–72**, 1679  
 Anal eroticism, 72, **514–515**  
 anal-sadistic stage and, 73, 515  
 coprophilia and, 346  
 encopresis and, 504  
 gifts and, 682  
 money and, 514, 519  
 stages and, 1652  
 sublimation and, 1679  
 symptoms and, 1714  
 Anal-sadistic stage, **73–74**  
 activity/passivity and, 17  
 anal eroticism and, 73, 515  
 anality and, 72  
 castration complex and, 252  
 compulsion and, 322  
 cruelty and, 355  
 encopresis and, 504  
 masochism and, 74, 518, 1021  
 obsessive neurosis and, 74, 211  
 sadism and, 74, 1525
- Anal stage  
 conflict and, 326  
 demand and, 388  
 mastery and, 1023–1024  
 modesty and, 1067  
 wish for a baby and, 1864  
*See also* Anal-sadistic stage
- “Análisis del asociar, del interpretar y de las palabras” (Alvarez de Toledo), 55  
 Anality, **72–73**  
 character and, 272  
 inferiority feelings and, 831  
 pregnancy fantasy and, 1302  
 projective identification and, 72, 1338  
*See also* Anal eroticism; Anal-sadistic stage; Anal stage  
 Analysand, **74–75**  
 “Analyse des rêves, L” (Jung), 89  
 Analyse Freudienne, 1084  
*Analyse freudienne*, 1084  
 “Analyse originelle, L” (Mannoni), 1010  
 Analysis. *See* Psychoanalytic treatment  
 “Analysis, Terminable and Interminable” (Freud), 16, **76–77**, 81, 182  
 on castration complex, 254  
 on change, 268  
 on character, 269–270  
 on ego, 466  
 on ego interests, 484  
 on externalization-internalization, 537  
 on female sexuality, 574  
 fourth analysis and, 603–604  
 on fusion/defusion, 659  
 on incompleteness, 806  
 on infantile sexual curiosity, 1590  
 on memory, 1043  
 on negative therapeutic reaction, 1126  
 on rejection of femininity, 575  
 on repetition compulsion, 1475  
 on repression, 1480  
 on termination of treatment, 76–77, 1737  
 on therapeutic alliance, 1741  
 on transference, 423  
 on unpleasure, 1827  
 on Witch metapsychology, 1868  
 on working-off mechanisms, 1877  
 on working-through, 1880  
 “Analysis of a Case of Infantile Obsessional Neurosis” (Sokolnicka), 1633  
 “Analysis of a Phobia in a five-year-old boy” (Freud). *See* “Little Hans” case  
 “Analysis of a Schizophrenic State of Depersonalization” (Rosenfeld), 1514  
 “Analysis of Psychotics, The” (Federn), 568  
*Analysis of the Self, The* (Kohut), 691, 784, 920  
 on action-thought, 13  
 on mirror transference, 1059  
 on narcissism, 1107  
 on narcissistic rage, 1115



## INDEX

Volume 1, pp. 1–662; Volume 2, pp. 663–1344; Volume 3, pp. 1345–1892

- on narcissistic transference, 1115  
 on self, 1579, 1580  
 on self-object, 1574  
 self psychology and, 1576  
 on twinship transference, 1810  
 Analysis under supervision, **1692–1693**  
 Analyst role. *See* Psychoanalyst role  
 Analytic object, 209, 1568  
 Analytic psychodrama, **77–79**  
 Analytic relationship. *See* Psychoanalyst role; Psychoanalytic treatment  
 Analytic technique. *See* Psychoanalytic treatment  
 “Analytic Therapy” (Freud), 95  
 Analytical psychology, **79–81**  
 alchemy and, 40, 115  
 amplification and, 67–68, 865  
 on animus/anima, 86–87, 313, 812, 903–904  
 archetypes in, 115  
 Canadian psychoanalysis and, 246  
 on counter-transference, 1779–1780  
 on ego, 463, 469–470  
 on extroversion/introversion, 537–538  
 on self, 469–470  
 on transference, 79, 80, 1779–1780  
*See also* Jung, Carl Gustav; Self (analytical psychology)  
*See also specific concepts*  
 Analytical Psychology Club, 79, 1871  
*Analytische Seelsorge* (Pfister), 1260  
 Analyzability, **81**, 1787  
*Anatomy of Human Destructiveness, The* (Fromm), 651  
 Anaximander, 313  
 Anderson, Robin, 896  
 Andersson, Ola, **81–83**, 82, 497, 1698–1699  
 Andkjær Olsen, Ole, 391  
 Andrade de Azevedo, Ana Maria, 859  
 Andrau, Renée, 806  
 André, Jacques, 574  
*André Berge: écrivain, psychanalyste, éducateur* (Berge), 162  
 Andreas, Friedrich Carl, 83  
 Andreas-Salomé, Louise, **83–84**  
 on alcoholism, 41  
 Bjerre and, 188  
 German psychoanalysis and, 674  
 Heller and, 732  
 on narcissism, 84, 1106, 1107  
 “On Transience” and, 1195  
 on partial drives, 1241  
 on sublimation, 1679  
 Tausk and, 1727  
 on *Young Girl’s Diary, A*, 1883  
 Andreoli, Antonio, 1701  
 Angelergues, René, 314, 912, 1435, 1876  
*Angoisse et la pensée magique, L’* (Odier), 1183  
*Angst. See* Anxiety  
 Animal behavior. *See* Ethology  
 Animal magnetism, **84–85**, 972–973, 1181, 1529  
 Animal phobias, 1273, 1275  
 Animistic thought, **85–86**  
 certainty and, 265  
 double and, 434  
 estrangement and, 524  
 fundamental rule and, 657  
 Mead on, 1035  
 omnipotence of thoughts and, 85, 86, 1189  
 taboo and, 85, 1724  
 Animus/anima, **86–87**, 313, 812, 903–904  
*Anlehnung. See* Anaclisis  
 Anna Freud Center, 230, 818  
 Anna Freud Foundation, 490  
 “Anna O.” case, **87–89**, 224, 1223–1224  
 cathartic method and, 87–89, 225, 257–258  
 creativity and, 352  
 daydreams and, 555, 1493  
 developmental processes and, 1329  
 feminist views of psychoanalysis and, 578  
 hypnosis and, 88, 225, 258, 768  
 memory and, 1042–1043  
 transference and, 88, 89, 225, 1787  
*Année psychologique, L’*-, **89–90**  
*Années brunes, Les*, 241  
 Annihilation anxieties, **90**, 1256, 1433  
*Annual of Psychoanalysis*, 278  
 Anorexia nervosa, 54, **91–92**, 138, 1578, 1665, 1686  
*Another Woman* (film), 294  
 Ansart, Pierre, 1632  
*Anschluss. See* Nazi Germany  
 Ansermet, François, 1701  
 Anthony, James, 601  
 Anthropology, **92–94**  
 Binswanger on, 181  
 civilization and, 299  
 double and, 434  
 ethno psychoanalysis and, 154, 409–410, 526–527  
 incest and, 804  
 Kardiner and, 906  
 magical thinking and, 1000  
 Malinowski, 1005  
 Mead, 410, 651, 1035  
 Róheim and, 93, 1000, 1509–1510  
 signifiers and, 1604  
 Anti-analysand, 75, 809  
 Anti-oedipal, 1436  
*Anti-Oedipus: Capitalism and Schizophrenia* (Deleuze and Guattari), **97–99**, 612  
 Anti-psychiatry, 98, 699  
 Anti-Semitism, **1437–1439**  
 Austrian psychoanalysis and, 133  
 Bernheim and, 170  
 Bjerre on, 189  
 Collège de Psychanalystes and, 314  
 Dutch psychoanalysis and, 1133  
 failure neurosis and, 544  
 Freud and, 899  
 Freud’s secondary schooling and, 1836  
 German romanticism and, 673  
 Hesnard and, 742  
 Hungarian psychoanalysis and, 765  
 Jung and, 902  
 Khan and, 698  
 Laforgue and, 1401, 1402  
 Langer on, 941  
 Loewenstein on, 291  
 Mauco and, 1034  
*Revue française de psychanalyse* and, 1498  
 U.S. psychoanalysis and, 1824  
 Weininger and, 1588  
*See also* Holocaust; Nazi Germany  
*Anti-Semitism: A Social Disease* (Simmel), 1612  
 Anticathexes, **94–95**  
 defense mechanisms and, 377  
 depression and, 395  
 desexualization and, 398  
 disorganization and, 420  
 hysteria and, 773  
 protective shield and, 1341  
 reaction-formations and, 94, 1449  
 repression and, 94, 1309, 1478, 1482, 1492  
 somnambulism and, 1636  
 tics and, 1756  
 Anticipatory ideas, **95–96**  
 Anticipatory mourning, 1196  
 Antigone, Lacan on, 526  
 Antilibidinal ego, **96–97**  
 Antinarcissism, **97**, 1114  
 Antiphrasis, 4  
 Antisocial behavior, 2, 18–19, 154, 972  
*See also* Criminology

Volume 1, pp. 1–662; Volume 2, pp. 663–1344; Volume 3, pp. 1345–1892

- “Antisocial Tendency, The” (Winnicott), 972
- “Antithetical Meaning of Primal Words, The” (Freud), 3–4, 1495, 1585, 1723
- Antoedipus* (Racamier), 1436
- Anxiety, **99–102**
- abandonment and, 2, 101
  - active technique and, 15
  - allergies and, 47, 48
  - annihilation, 90, 1256, 1433
  - autism and, 1809
  - automatic, 734, 1604, 1639, 1639
  - birth and, 185
  - birth trauma and, 834
  - Bleger on, 194
  - Brun on, 231
  - castration complex and, 253
  - danger and, 102, 364
  - Darwinism and, 366
  - death and, 370
  - disintegration, 90, 418, 605, 1320
  - ego and, 466, 471–472, 479
  - eight-month, 1186, 1664
  - encopresis and, 504
  - envy and, 509
  - fear and, 562–563
  - gifts and, 682
  - helplessness and, 734
  - id and, 779
  - infantile psychosis and, 826
  - inhibition and, 832
  - libido and, 969
  - Mom on, 1068
  - neurasthenia and, 1136
  - New Introductory Lectures on Psychoanalysis* on, 1145
  - orality and, 1202–1203
  - paranoid position and, 1231
  - passage to the act and, 18
  - patient physical position and, 541, 542
  - phobias and, 1273, 1274
  - protective shield and, 1340
  - psychotic panic and, 1416
  - quota of affect and, 1433–1434
  - Real and, 1454
  - seduction theory and, 1592
  - self-mutilation and, 1572
  - shame and, 1599
  - specific actions and, 1638–1639
  - splitting of the object and, 1642
  - Stekel on, 1131–1132
  - subject’s desire and, 1678
  - substitute formations and, 1680
  - suffering and, 1683
  - superego and, 1691
  - symptoms and, 1715
  - trauma and, 1801
  - uncanny and, 1816
  - See also* Castration anxiety; Signal anxiety
  - “Anxiety and Infancy” (Spitz), 1664
  - Anxiety dreams, **102–103**, 1150
  - Anxiety hysteria. *See* Phobic neurosis
  - Anxiety neurosis, 19, 420, 1135–1137, 1681
  - Anzieu, Annie, 896, 1297, 1653
  - Anzieu, Didier, **103–105**, 1613–1614
    - adhesive identification and, 24, 815
    - “Aimée” case and, 38
    - Association psychanalytique de France and, 122, 124
    - Berge and, 162
    - Bick and, 104, 178
    - on body image, 197
    - Congrès des psychanalystes de langue française des pays romans and, 331
    - dream screen and, 441
    - on ego, 465
    - French psychoanalysis and, 613
    - French psychoanalytic establishment split (1964) and, 104, 122
    - on Freud’s self-analysis, 643, 754
    - group analysis and, 610, 710, 1371
    - on heroic identification, 738–739
    - on identification, 790
    - on incompleteness, 805
    - on infant development, 815
    - infant observation and, 816
    - on introspection, 871
    - Journal de la psychanalyse de l’enfant* and, 896
    - on maternal, 1028
    - on mother-infant bond, 1613
    - on mythology, 1097
    - on negative therapeutic reaction, 1127
    - Nouvelle Revue de psychanalyse* and, 1162
    - on object, 1170
    - on paradox, 434, 1127, 1226
    - photograph of, I:pl.4
    - on pleasure in thinking, 1289
    - on protective shield, 1341
    - on psychic envelopes, 739
    - Rorschach and, 1394
    - Schilder and, 1538
    - on self, 1567
    - on self-consciousness, 1569
    - Société française de psychanalyse and, 1619
    - Société psychanalytique de Paris and, 1626
    - sociology and, 1632
    - on tenderness, 1736
    - Union of Psychoanalysts and Psychologists and, 1034
    - on visual arts, 1842
    - on work, 1876
    - See also* Skin-ego
- Anzieu, Marguerite, 104
- APA. *See* American Psychoanalytic Association; Asociación psicoanalítica Argentina
- Apathy, 506
- APDEBA (Asociación Psicoanalítica de Buenos Aires), 118
- Apel, Karl-Otto, 1699
- “Aperçu sur l’histoire de la littérature psychanalytique” (Viderman), 1834–1835
- APF. *See* Association psychanalytique de France
- Aphanisis, **105–106**
- annihilation anxieties and, 90
  - female sexuality and, 574
  - phallus and, 1264
- Aphasia, **106–107**, 143, 212, 1042
- Aphemia, 106
- Apollinaire, Guillaume, 45, 223, 708
- Apollon, Willy, 246
- Aportaciones al concepto de objeto en psicoanálisis* (Baranger), 150
- Apparatus, 32
- Applied psychoanalysis, **107–108**
- Apprenti-historien et le maître-sorcier (L’-)* (Aulagnier), **110–111**, 130, 142
- Après coup*. *See* Deferred action
- APUI (Association pour une Instance Tierce des Psychanalystes), 957, 1084
- Aragão de Souza Pinto, Jenserico, 213
- Aragon, Louis, 730, 1283, 1695
- Aranha, Zenaira, 215
- Arar, Fatima, 1155
- Aray, Julio, 1832, 1833
- Arbours Association, 699
- Archaic, **111–112**
- Anzieu on, 104, 790
  - archaic mother, 112–113, 365
  - cultural transmission and, 357, 358
  - disintegration anxieties and, 418
  - dreams and, 112, 1007
  - phobias and, 1274
  - tenderness and, 1736
- Archaic identity. *See* “Participation mystique”
- Archaic mother, **112–114**, 365

## INDEX

Volume 1, pp. 1–662; Volume 2, pp. 663–1344; Volume 3, pp. 1345–1892

- “Archaïque et le profond dans la pensée de Melanie Klein, L” (Petot), 1326
- Archeological metaphors, **114**, 296
- archaic and, 111, 112, 113
- constructions and, 336–337
- history and, 750
- memories and, 1040–1041
- Archeology, 1080
- Archetypal psychology, 115
- Archetypes, **115**
- amplification and, 67
- collective unconscious and, 115, 313
- complexes and, 321
- directed daydreams and, 414
- imago and, 800
- literature and, 986
- midlife crisis and, 1055
- numinous and, 115, 1165
- self and, 115, 1581
- synchronicity and, 1720
- transference and, 1779
- Archimedes, 1683
- Archives de psychologie*, 1620
- Archives de psychologie, Les*, **115–116**, 301–302, 592
- Archivio generale di neurologia e psichiatria*, 963, 1508
- Arcila, G., 315
- Arendt, Hannah, 1439
- Argelander, Hermann, 1602
- Argentine Psychoanalytic Association. *See* Asociación psicoanalítica Argentina
- Argentinian psychoanalysis, **116–119**, 241
- analytic psychodrama and, 78
- Bleger, 118, 193–194
- Cárcamo, 55, 117, 247–248
- Garma and, 665
- International Psychoanalytical Association and, 858
- Langer and, 117, 118, 665, 941
- Mom and, 118, 1068
- Pichon-Rivière and, 117, 118, 193, 1284–1285
- Revista de psicoanálisis*, 1496
- Uruguayan psychoanalysis and, 1829
- Arieti, Silvano, 1541
- Aristotle, 225, 256, 445
- hermeneutics and, 738
- on psyche, 1349
- sexuation and, 1595
- on thought identity, 1749
- Arlow, Jacob, 48, **119–120**, 487, 897, 1148, 1610
- Armand Trousseau Children’s Hospital, **120–121**, 427
- Aron, Raymond, 935
- Aron, W., 1640
- ARPAC (Asociación Regiomontana de Psicoanálisis, L’), 1052
- Arrivé, Michel, 982
- Arrogance, **121–122**, 1141
- Arrué, Omar, 285
- Art. *See* Creativity; Visual arts
- Art of Loving, The* (Fromm), 651
- Art therapy, 985
- Artaud, Antonin, 46, 1152, 1696
- Artaza, Ximena, 284, 285
- Artemis, 1080
- Artesanias psicoanalíticas* (Baranger), 150
- Arthus, Henri, 1395
- Artières, Michel, 1628
- Aryen, son rôle social, L’* (Vacher de Lapouge), 1437
- Ärztgesellschaft für Psychoanalyse (Switzerland), 231
- “As if” personality, **122**, 405
- anality and, 72
- autistic capsule and, 138
- blank psychoses and, 191
- borderline conditions and, 122, 202
- lies and, 972
- Ascher, Jacques, 42, 900, 1439
- Asociación de psicoanalítica de Madrid, 1638
- Asociación psicoanalítica argentina, 1637
- Asociación psicoanalítica Argentina (APA), 4, 118
- Alvarez de Toledo and, 55
- Brazilian psychoanalysis and, 214
- Cárcamo and, 247
- founding of, 117
- Garma and, 665
- Perestrello, Danilo and, 1250
- Pichon-Rivière and, 1284
- Racker and, 1440
- Rascovsky and, 1447
- Revista de psicoanálisis* and, 117, 248, 1447, 1496
- Asociación Psicoanalítica de Buenos Aires (APDEBA), 118
- Asociación Psicoanalítica del Uruguay, 150
- Asociación psicoanalítica du Chili, 284
- Asociación psicoanalítica mexicana (APM), 1051, 1052
- Asociación Regiomontana de Psicoanálisis, L’ (ARPAC), 1052
- Asociación Venezolana de Psicoanálisis (ASOVEP), 1833
- ASOVEP (Asociación Venezolana de Psicoanálisis), 1833
- “Assistant Producer, The” (Nabokov), 493
- Associação Brasileira de Psicanálise (ABP), 215, 1012
- Associação brasileira de psicoterapia analítica de grupo, 217
- Associação jungiana brasileira, 217
- Association, 320, 337–338, 1424, 1680
- See also* Free association
- Association de la Cause freudienne, 455–456, 612
- Association de la fondation du champ freudienne, 455
- Association de santé mentale, 610, 911, 955
- Association des Psychanalystes de Belgique, 157, 956
- Association for Child Psychoanalysis, 925, 1658
- Association for the Advancement of Psychoanalysis, 1558, 1644, 1745–1746
- Association for the Psychiatric Treatment of Offenders, 1543
- Association Freudienne internationale (AFI), 612, 1084
- Association Internationale d’Études Médico-Psychologiques et Religieuses, 156
- Association Internationale d’histoire de la psychanalyse. *See* International Association of the History of Psychoanalysis
- Association Internationale Psychothérapie et de Psychologie Catholique, 290
- Association Médico-Psychologique d’Aide aux Religieux, 156
- Association mondiale de la psychanalyse. *See* World Association of Psychoanalysis
- Association pour une Instance Tierce des Psychanalystes (APUI), 957, 1084
- Association Psychanalytique de France (APF), **122–124**
- Anzieu and, 104
- Berge and, 162
- Confrontation* and, 327
- Congrès des psychanalystes de langue française des pays romans and, 331
- Documents et Débats*, 123, 124, 426
- École de la Cause freudienne and, 455
- École freudienne de Paris and, 458
- Favez and, 122, 561
- Fédida and, 569
- founding of, 611
- Granoff and, 692

Volume 1, pp. 1–662; Volume 2, pp. 663–1344; Volume 3, pp. 1345–1892

- Lagache and, 935  
*Language of Psychoanalysis, The*, 944  
*Nouvelle Revue de psychanalyse* and, 1162  
 recent role of, 613  
 Smirnoff and, 122, 123, 1617  
 Société psychanalytique de Paris and, 1626  
 Assoun, Paul-Laurent  
 on determinism, 401  
 on epistemology, 1370  
 on hatred, 729  
 on parricide, 1239  
 on philosophy, 1270  
 Asthma, 47, **124–125**, 1613, 1665  
 Astor, David, 230  
 Athanassiou, Cléopâtre, 995–996, 1499  
 Atheism, 159  
 Athena, 574  
 Atkinson, James Jasper, 1303, 1320, 1321  
 Attachment, **125–126**  
 adolescence and, 29  
 American Academy of Psychoanalysis and, 59  
 ethology and, 528  
 infant development and, 814–815  
 infantile neurosis and, 821–822  
 maternal care and, 1029–1030  
 Robertson on, 1509  
 skin and, 1612  
*See also* Attachment theory  
 Attachment theory, 125, 126  
 abandonment and, 2  
 experience of satisfaction and, 537  
 Fairbairn and, 546  
 on primary need, 1316  
 Attacks on linking, **983–984**  
 “Attacks on Linking” (Bion), 51, 121, 983  
 Attention, **126–128**  
 alpha function and, 952  
 dismantling and, 419  
 dream-like memory and, 439  
 evenly-suspended, 530–531  
 hypercathexis and, 767  
*Attention and Interpretation* (Bion), 127, 184, 439, 1464  
 Attia, Samia, 1155  
 Attías, Addys, 1833  
 Attunement, 1029  
 Atwood, George E., 1307, 1567, 1827  
 “Au-delà du ‘principe de réalité?’” (Lacan), 799  
 “Au-dessus de la méele” (Rolland), 1511  
*Au vif de l’infantile* (Guignard), 830  
 Aubert–Godart, Anne, 1304  
 Aubry, Carlos, 1  
 Aubry Weiss, Jenny, **128–129**, 195, 610, 1732  
 Auersberg, Alfred, 248  
*Aufhebung*, 1674  
 Aufreiter, Friedl, 243  
 Aufreiter, Hans, 243  
 Augustine, St., 930  
 Aulagnier-Spairani, Piera, 110–111, **129–130**  
 on alienation, 44, 111  
 on autism, 137  
 on autohistorization, 142, 1385  
 on body image, 197  
 Canadian psychoanalysis and, 244  
 on certainty, 266  
 on complementary zone-object, 189  
*Confrontation* and, 327  
 École freudienne de Paris and, 457, 458  
 on ego, 467  
 on ego ideal, 480  
 on encounter, 505  
 Enriquez-Joly and, 506  
 French psychoanalysis and, 129, 613  
 on fusion/defusion, 659  
 on *I*, 110–111, 130, 142, 775–776, 793, 1119, 1170  
 on idealization, 784  
 on ideational representation, 785–786  
 on identificatory project, 790, 793–794  
 on ideology, 795, 796  
*Inconscient, L’* and, 528, 611, 806, 807, 1835  
 on *infans* stage, 812, 813–814  
 on infant development, 815  
 on infantile psychosis, 826–827  
 on intergenerational phenomena, 846  
 on internal/external reality, 848  
 on knowledge instinct, 918  
 on listening, 984  
 on logic, 990  
 on megalomania, 1036–1037  
 on need for causality, 1119–1120  
 on object, 1170  
 on pass, 1243, 1251  
 on passion, 1244  
 on perversion, 1259  
 photograph of, I:pl.5  
 on pictogram, 221, 1285–1287, 1312–1313  
 on primal, 1312–1313  
 on primary/secondary processes, 1328, 1840  
 on process, 1328  
*Psychanalyse, La* and, 1348  
 on psychic causality, 1355  
 on psychic temporality, 1360  
 on psychoses, 192, 1404, 1839–1840  
 on psychotic potential, 1417–1418  
 Quatrième Groupe and, 129, 529, 611, 807, 1429, 1430, 1645  
 on representability, 1477  
 on representation, 782  
 Schilder and, 1538  
 on sense/nonsense, 1584, 1585  
 Société française de psychanalyse and, 1619  
 Société psychanalytique de Paris and, 1628  
 on subject, 1674  
 on time, 1757–1758  
*Topique* and, 130, 807, 1759  
 on truth, 1805  
 on uncanny, 1816  
 on visual, 1841  
 Austin, John, 1153  
 Australian Association of Group Psychotherapists, 132  
 Australian psychoanalysis, **130–132**  
 Austregesilo, Antonio, 214  
 Austrian psychoanalysis, **132–136**, 207  
*See also* Wiener psychoanalytische Vereinigung  
 Austrian Society for the Study of Child Psychoanalysis, 135  
 Authoritarian personality, 1632  
*Authoritarian Personality, The* (Adorno et al.), 32, 1018  
 Autism, **136–138**  
 Abraham, Karl on, 6  
 adhesive identification and, 24, 137  
 Bettelheim on, 136, 173, 502–504  
 birth trauma and, 1803  
 black holes and, 189–190, 218  
 breakdown and, 218  
 defenses and, 139  
 deprivation and, 397  
 dismantling and, 419, 420  
 imaginary and, 799  
 infantile, 71, 136  
 infantile psychosis and, 824, 825, 828  
 Mahler-Schönberger on, 136, 139, 503, 1001  
 Putnam Children’s Center and, 208  
 repetition and, 1474  
 self-mutilation and, 1572, 1573  
 skin and, 1613  
 sucking and, 1682  
 tube-ego and, 1806

## INDEX

Volume 1, pp. 1–662; Volume 2, pp. 663–1344; Volume 3, pp. 1345–1892

- Tustin on, 137, 138, 139, 420, 1809  
*Autism and Childhood Psychosis* (Tustin), 138, 189, 1682  
*Autistic Barriers in Neurotic Patients* (Tustin), 138, 189, 1806  
 Autistic capsule/nucleus, **138–139**  
 Autistic defenses, **139**  
 Autistic object, 1573  
*Autistic States in Children* (Tustin), 420  
*Auto-analyse, L': Son rôle dans la découverte de la psychanalyse par Freud* (Anzieu), 643  
 Auto-sadism, 1577  
 “Autobiographical Study, An” (Freud), **139–140**  
 on Darwinism, 366  
 on fantasy, 551  
 on hypnoid states, 768  
 on latency period, 946  
 on libido, 970  
 on phylogenesis, 1277  
 on repetition compulsion, 1475  
 on seduction scenes, 1565  
 Autobiography, **140–141**  
*Autobiography of a Schizophrenic Girl* (Sechehaye), 1557  
 Autoeroticism, **141–142**  
 alcoholism and, 41  
 anaclysis and, 68, 69, 1752–1753  
 anal-sadistic stage and, 74  
 autism and, 136  
 choice of neurosis and, 288  
 desexualization and, 399  
 dipsomania and, 412, 413  
 enuresis and, 507  
 fragmentation and, 605  
 homosexuality and, 757  
 maternal and, 1027, 1028  
 narcissism and, 1105  
 object loss and, 994  
 Oedipus complex and, 1186  
 substitute formations and, 1680  
 sucking and, 141, 1681–1682  
 suicide and, 1687  
*See also* Masturbation  
 Autohistorization, **142**, 1385  
 Automatic anxiety, 734, 1604, 1639, 1639  
 Automatic writing, 987, 1695  
 Automatism, **142–143**, 323, 386, 1672  
*Automatisme psychologique* (Janet), 1672  
*Automatisme psychologique, L'* (Janet), 769  
*Automatisme psychologique, L'* (Janet), 1685  
 Automization, 473–474  
 Autonomy, 3, 29, 91  
*See also* Ego autonomy  
 Autoplastic behavior, **144**  
*Autoportrait d'une psychanalyste* (Dolto-Marette), 426  
 Autosuggestion, **144**, 1432  
*Autre Écrits* (Lacan), 460, 1552  
*Autumn Sonata* (film), 294  
*Aux carrefours de la haine* (Enriquez-Joly), 506  
 Avant-garde, 45  
 Avery, Tex, 294  
 Avoidance, 1274  
 “Ayahuasca” (Alvarez de Toledo), 55  
 Ayala, Jaime, 1052  
 Ayme, Jean, 1766  
 Ayrosa, Carneiro, 214  
 Azim, Hassan, 244  
 Aziz, Robert, 1720  
 Azoubel, David, 217
- B**  
*Babel of the Unconscious, The* (Mehler), 1086  
 Babies. *See* Infancy  
 Babinski, Joseph, 1414, 1529  
 Babits, Mihály, 765  
 Bach, Helmut, 1131  
 Bachelard, Gaston, **145–146**, 400, 559, 1367–1368, 1550, 1668  
 Bachelard, Pierre, 1350  
 Bachmann, Ingeborg, 706  
*Backward Child and His Mother, The: A Psychoanalysis Study* (Mannoni), 456  
 Badiou, Alain, 241  
 Baer Bahia, Alcyon, 214, 248  
 Baginsky, Adolf, **146**, 842  
 Baginsky, Joseph, 637  
 Bahia, A. A., 215, 216, 217  
 Bahr, Hermann, 1214–1215  
 Baillarger, Jules, 1178  
 Bailly, Jean Sylvain, 84  
 Bailly, René, 458  
 Bak, Robert C., I:pl.6, **146–147**, 391, 764, 1148  
 Bakan, David, 900  
 Balbo, Gabriel, 388–389  
 Baldacci, Jean-Louis, 1630  
 Balderas, R., 1052  
 Balibar, Etienne, 241  
 Balint, Enid  
 Australian psychoanalysis and, 132  
 Balint, Michael and, 148  
 Balint groups and, 147  
 British psychoanalysis and, 699–700  
 Tavistock Clinic and, 1728  
 Balint, Michael, **148–149**  
 on alcoholism, 42  
*amae* and, 56  
 Australian psychoanalysis and, 131, 132  
 Balint groups and, 147, 149  
 Bick and, 177  
 British psychoanalysis and, 697, 699–700  
 on change, 268  
 on character, 273  
 on clinging instinct, 307, 737  
 on counter-transference, 1090  
 on dependence, 392  
*Development of Psycho-Analysis* and, 407  
 on ego-libido/object-libido, 486  
 on elasticity, 494  
 Ferenczi and, 148, 149, 328, 581  
 on frame of psychoanalytic treatment, 607  
 on genital love, 671  
 German psychoanalysis and, 1060  
 Groddeck and, 706  
 Hungarian psychoanalysis and, 765, 766  
 Hungarian School and, 148, 700, 763, 764  
 on id, 779  
 on internal/external reality, 848  
 on libido, 969  
 Main and, 1003  
 on mutual analysis, 1090  
 on narcissism, 97, 148–149, 151, 1111  
 on primary love, 1314–1315  
 on primary narcissism, 148–149, 151, 1315  
*Psychanalyse, La* and, 1348  
*Psyche* and, 1351  
 Raimbault, Émile and, 1442  
 on regression, 160–161, 1709  
 Sachs and, 148, 1523  
 on self, 1582  
 on sucking, 1682  
 Tavistock Clinic and, 1728  
 on tenderness, 1736  
 on transference love, 1785  
 Balint groups, **147–148**, 149, 700, 1003, 1442  
 Balint-Szekely-Kovács, Alice, 148, **149–150**  
 Hungarian psychoanalysis and, 765, 766  
 Hungarian School and, 764  
 on primary narcissism, 1315  
*Zeitschrift für psychoanalytische Pädagogik* and, 1886  
 Balkany, Charlotte, 1653  
 Ball, Benjamin, 306, 1528  
 Ballesteros, López, 1637

Volume 1, pp. 1–662; Volume 2, pp. 663–1344; Volume 3, pp. 1345–1892

- Ballet, Gilbert, 1136  
 Bally, Charles, 1556  
 Bally, Gustav, 1505  
 Bally, Gustave, 1703  
 Balmory, Marie, 1143  
 Balsam, Rosemary H., 898  
 Barag, Gerda, 876  
 Barag, Gershon, 876  
 Barajas, Rafael, 1051  
 Barande, Ilse, 610, 1004, 1499  
 Barande, Robert, 1630  
   CCTP and, 264  
   group analysis and, 610  
   *Inconscient, L'* and, 807  
   on indications/contraindications for psychoanalysis, 809  
   on silence, 1610  
   Société psychanalytique de Paris and, 1626, 1628  
   Viderman and, 1835  
 Baranès, Jean-José, 846, 1266, 1499  
 Baranger, Madeleine, 150  
   Argentinian psychoanalysis and, 118  
   Mom and, 1068  
   Uruguayan psychoanalysis and, 1829  
 Baranger, Willy, **150–151**  
   Argentinian psychoanalysis and, 118–119  
   Federación psicoanalítica de América latina and, 566  
   Italian psychoanalysis and, 881  
   Mom and, 1068  
   Uruguayan psychoanalysis and, 1829  
 Bard, Janet Rioch, 59  
 Bargues, Raymonde, 129  
 Barinbaum, Gisela S., 1146  
 Barker, Pat, 696  
 Barrau, Bernard, 1653  
 Barrett, William G., 1529, 1532  
 Bartemeir, Leo, 242, 725  
 Barthes, Roland, 1099, 1247  
 Barthes, Rolland, 1668  
 Basaglia, Franco, 880  
 Basic anxiety, 90  
 Basic assumptions, **151**, 709–710, 711  
 Basic fallacy, 153  
 Basic fault, **151–152**, 161, 1090  
*Basic Fault, The: Therapeutic Aspects of Regression* (Balint), 148, 151  
*Basic Neurosis, The—Oral Regression and Psychic Masochism* (Bergler), **152–153**, 163  
*Basic Principles of Psychoanalysis* (Brill), 960  
*Basic Problems of Ethnopsychiatry* (Devereux), **153–154**  
 Basic schizoid position, 96–97  
 Basic trust, 1598  
*Basic Writings of Sigmund Freud, The* (Brill), 227  
 Bass, Alan, 241  
 Bassine, Philippe, 277  
 Bastide, Roger, 93, 153, 1774  
 Bataille, Georges, 204  
 Bataille, Laurence, 1211  
 Bataille, Sylvia, 1101  
 Bateson, Gregory, 1720  
   on double bind, 433  
   Lieberman and, 980  
   Mead and, 1035  
   Pankow and, 1222  
   on paradox, 1225  
   U.S. psychoanalysis and, 1825  
 Baudelaire, Charles, 974  
 Baudouin, Charles, **154–155**  
   *Archives de psychologie, Les* and, 302  
   on autosuggestion, 144  
   Belgian psychoanalysis and, 158  
   Desoille and, 400  
   Dubal and, 450  
   Institut Jean-Jacques Rousseau and, 302  
   *Psyché* and, 1350  
   Sechehaye and, 1556  
   on suggestion, 1431–1432  
   Swiss psychoanalysis and, 1700  
 Baudrillard, Jean, 241, 327  
 Baudry, Jean-Louis, 294  
 Bauduin, Andrée, 157  
 Bauer, Ida, **155–156**  
   *See also* “Dora” case  
 Bauleo, Armando, 328  
 Baumeyer, Franz, 677, 679  
 Bayle, Gérard, 1273, 1499, 1628, 1629, 1630  
 Beard, George M., 1135, 1822  
 Beaunis, Henri, 89  
 Bechtereve, Vladimir, 1515  
 Beck-Dvorzak, Maja, 1884  
 Becker, Alois, 133, 1858  
 Beckett, Samuel, 1457, 1568  
*Bedeutung der Psychoanalyse für die Geisteswissenschaften, Die* (Rank and Sachs), 1842  
 Bedwetting. *See* Enuresis  
 Beerholdt, A., 677  
 Beethoven, Ludwig van, 1658, 1659  
*Beethoven and His Nephew* (Sterba and Sterba), 1658  
 Bégoin, Jean  
   on dismantling, 419  
   French psychoanalysis and, 610  
   Martinican psychoanalysis and, 1014  
   Portuguese psychoanalysis and, 1297  
   *Revue française de psychanalyse* and, 1499  
 Bégoin-Guignard, Florence, 610  
*Begriff der “Deutung” in der Psychoanalyse, Der* (Bernfeld), 169  
 Behaviorism, 9, 289, 309, 477  
 Behn-Eschenburg, Hans, 1886  
*Being and Nothingness* (Sartre), 1535  
*Being and Time* (Heidegger), 181  
 Being/having opposition, 788  
 Being/nonbeing opposition, 326  
 Beirnaert, Louis, **156**, 266, 611  
 “Beiträge zur infantilen Sexualität” (Wulff), 1881  
 Bejarano, Angelo, 426, 610  
 Beland, Hermann, 679  
 Belgian psychoanalysis, **156–158**, 450–451, 956  
 Belgische School voor Psychoanalyse (École Belge de Psychanalyse), 158  
 Belgische Vereniging voor Psychoanalyse (Société Belge de Psychanalyse), 157–158, 451  
 Belief, **158–159**  
 Belkin, Aron, 1519  
 Bellak, Leopold, 1395  
 Bellak, Sonya Soral, 1395  
 Bellanova, Piero, 880  
 Bellour, Raymond, 294  
 Ben Rejeb, Riadh, 1156  
 Ben-Tal, Vicky, 876  
 Bénassy, Maurice  
   Dubal and, 450  
   French psychoanalysis and, 609  
   Parcheminey and, 1236  
   *Revue française de psychanalyse* and, 1499  
   Schlumberger and, 1542  
   Société psychanalytique de Paris and, 1625  
 Bencheckroun, Mohammed Fouad, 1155  
 Benchemsi, Zhor, 1156  
 Bender, Lauretta, 1538  
 Benedek, Therese, **159–160**  
   Chicago Psychoanalytic Institute and, 278  
   German psychoanalysis and, 675  
   Hungarian School and, 764  
   on parenthood, 1237  
   Swedish psychoanalysis and, 1699  
 Benedetti, Gaetano, 1404  
 Benedict, Ruth

## INDEX

Volume 1, pp. 1–662; Volume 2, pp. 663–1344; Volume 3, pp. 1345–1892

- on civilization, 299  
 Fromm and, 651  
 Mead and, 1035  
 on Oedipus complex, 1186  
 U.S. psychoanalysis and, 1825
- Benevolence, 8, 531, 1144
- Benhabib, Loufti, 1155
- Benhamou, Hervé, 1520
- Benign/malignant regression, **160–161**
- Benjamin, Harry, 1799
- Benjamin, Jessica, 576, 577
- Benmiloud, Khaled, 1155
- Bennani, Jalil, 1155
- Bennett, Edward A., 80
- Benoit, Pierre, 428
- Benounich, Abdelhag, 1155
- Benová, M., 361
- Benoziglio, Norbert, 1701
- Benslama, Fethi, 1156
- Benveniste, Émile, 4, 981, 982, 1604
- Beratis, Stavroula, 701
- Berdürfnis*. See Need
- Berenstein, Isidoro, 118
- Berg, Charles, 82
- Berge, André, **161–162**  
 Centre psychopédagogique Claude-Bernard and, 161, 265, 559, 560, 609  
 Clark-Williams trial and, 161, 304  
 Laforgue and, 934  
*Psyché* and, 161, 1350  
 Schlumberger and, 1541  
 Société française de psychanalyse and, 161, 162, 1619  
 surrealism and, 1696
- Berger, Margarethe, 287
- Berger, Maurice, 1372
- Bergeret, Jean  
 on character, 270  
 French psychoanalysis and, 613  
 on humor, 763  
 Laforgue and, 934  
 on “Little Hans” case, 820  
 on mastery, 1025  
 on neuroses, 1139  
 North African psychoanalysis and, 1154  
 on psychic structure, 1359  
 on sadism, 1526  
 on self, 1580  
 on violence instinct, 1839
- Bergès, Jean, 388–389
- Berggasse 19, Wien IX, III:pl.10, **162–163**, 642
- Bergler, Edmund, 152–153, **163**, 1022  
 on neutrality, 1144  
 photograph of, I:pl.7  
 on silence, 1610
- Bergman, M., 846
- Bergmann, Martin, 568
- Bergsmann, Mihály. See Balint, Michael
- Bergson, Henri, 485  
*Évolution psychiatrique*, L' and, 532, 539  
 hypnosis and, 769  
 Le Bon and, 953  
 libido and, 968  
 on memory, 1042, 1043  
 Minkowski and, 1057  
 on psychic apparatus, 1351  
 Putnam and, 1425
- Bérillon, Edgar, 331
- Berke, Joseph, 699
- Berkeley, George, 847
- Berlin Group, 322
- Berlin Institute of Psychoanalysis. See Berliner Psychoanalytisches Institut
- Berliner, Bernhard, 1529
- Berliner Psychoanalytische Poliklinik, **164–165**, 492, 493, 675, 1069
- Berliner Psychoanalytische Vereinigung, 674, 1542, 1611
- Berliner Psychoanalytisches Institut (BPI), **165–166**  
 Abraham, Karl and, 5, 6, 165  
 Alexander and, 42, 166  
 Berliner Psychoanalytische Poliklinik and, 164–165  
 Bernfeld and, 166, 169  
 Boehm and, 165, 198, 199  
 Chicago Psychoanalytic Institute and, 277–278  
 founding of, 61  
 Sachs and, 165, 166, 1523  
 Schultz-Hencke and, 1547  
 Simmel and, 165, 166, 1611  
 training model of, 62, 1769, 1771
- Berman, Anne, **166–167**, 608, 1624
- Berman, Annette, 204
- Berman, Antoine, 241
- Berman, Emanuel, 877
- Bermann, Gregorio, 116
- Bernard, Paul, 540
- Bernard, Walter, 1640
- Bernardi, Ricardo, 1829
- Bernays, Edward, 1655
- Bernays, Eli, 634
- Bernays-Freud, Anna, **633–634**
- Bernays-Freud, Minna, **167–168**, 621, 1502
- Berne, Eric, 568
- Berner, Wolfgang, 133, 1858
- Bernfeld, Siegfried, **168–170**  
 on Berliner Psychoanalytisches Institut, 166, 169  
 Fenichel and, 169, 579  
 on Freud, Josef, 627  
 German psychoanalysis and, 675  
 Hietzing Schule and, 745  
 Lampl and, 939  
 Lampl-de Groot and, 938  
 Lehrinstitut der Wiener psychoanalytischen Vereinigung, 959  
 Marxism and, 169, 1017  
 photograph of, I:pl.8  
 San Francisco Psychoanalytic Society and Institute and, 1529  
 Schultz-Hencke and, 1547  
 on *Secrets of a Soul, The*, 1562  
*Sigmund Freud: Life and Work* and, 974  
 U.S. psychoanalysis and, 1824  
 Wiener psychoanalytische Vereinigung and, 1857, 1858  
*Young Girl's Diary*, A and, 1883  
*Zeitschrift für psychoanalytische Pädagogik* and, 1886
- Bernhardt, Ernst, 79
- Bernheim, Hippolyte, **170–171**
- British psychoanalysis and, 695
- “Cécilie M.” case and, 239
- cathartic method and, 225
- Delboeuf and, 144, 384  
 on dreams, 436  
 Freud and, 332  
 Freud's translation, 403  
 on hypnosis, 769  
 Liebeault and, 972  
 on negative hallucination, 1124  
 on suggestion, 1684–1685  
 U.S. psychoanalysis and, 1822
- Bernier, Jean, 37–38
- Bernstein, P., 1157
- Bertalanffy, Ludwig von, 1371
- Bertrand, Alexandre, 85, 973
- Besaçon, Alain, 750
- Besaçon, Guy, 1813
- Besdine, Matthew, 1289
- Besserman Vianna, Helena, 216, 328
- Beta-elements, **171**, 184  
 alpha-elements and, 50, 171  
 beta-screens and, 171–172  
 hallucinosis and, 723

Volume 1, pp. 1–662; Volume 2, pp. 663–1344; Volume 3, pp. 1345–1892

- maternal reverie and, 1030–1031  
 proto-thoughts and, 1343  
 Beta-screen, **171–172**, 340  
 Betlheim, Stjepan, 727, 1884  
 Bettelheim, Bruno, 136, **172–173**, 461, 502–504, 986, 1553  
*Beyond Good and Evil* (Nietzsche), 201  
*Beyond the Pleasure Principle* (Freud), **173–175**, 975  
 on anxiety dreams, 103  
 on automatism, 143  
 on binding/unbinding, 179  
 on castration complex, 254  
 on childhood, 280  
 on children's play, 283  
 collective psychology and, 311  
 on conflict, 326  
 on constancy principle, 1323  
 on death instinct, 371, 372  
 on discharge, 417  
 on disorganization, 420  
 on drives, 445, 446  
 dualism and, 1070  
 on ego, 464  
*Ego and the Id, The* and, 471, 472  
 on ego functions, 478  
 on ego-instincts, 483  
 on ego-libido/object-libido, 485  
 on Eros, 511–512, 513  
 on estrangement, 524  
 excitation and, 534  
 on facilitation, 543  
 on fate neurosis, 556  
 on fear, 563  
 on *Fort-da* game, 599, 927, 994, 1710  
 on free energy/bound energy, 617  
 on fusion/defusion, 658, 659  
 on gifts, 683  
 on hypercathexis, 767  
 on infant observation, 817  
 on libido, 485, 968  
 on masochism, 1021  
 on mythology, 1097  
 on narcissism, 1105  
 on nightmares, 1149–1150  
 on Nirvana principle, 1151  
 “On Narcissism” and, 1191  
 on oral eroticism, 516  
 on orality, 1202  
 on pain, 1281  
 on pleasure, 894  
 on pleasure principle, 1291, 1326  
 on primary masochism, 1315  
 on protective shield, 1340  
 on psychic representative, 1358  
 psychoanalytic research and, 1379  
 publication of, 639–640, 753  
 on punishment dreams, 1422–1423  
 on racism/anti-Semitism, 1438  
 Real and, 1453–1454  
 on repetition, 1473  
 on repetition compulsion, 1470, 1474  
 on repression, 1479  
 on sadism, 1526  
 on sexuality, 1593  
 on topographical point of view, 1760  
 on transference neuroses, 1786  
 on trauma, 1801  
 on wish-fulfillment, 1083, 1865  
 Bianchedi, Elizabeth, 888  
 Bible, 119, 624, 1269  
 Biblioteca de Psicoanálisis, 117  
 Bibliothèque de psychanalyse, 611, 935  
 Bibliothèque Sigmund Freud, 1629  
 Bibring, Edward, **176**  
 on altruism, 54  
 Bornstein and, 205  
 Boston Psychoanalytic Society/Institute and, 207  
 Canadian psychoanalysis and, 242  
 Czech psychoanalysis and, 361  
*Gesammelte Werke*, 680  
 Hartmann and, 727  
 Lehrinstitut der Wiener psychoanalytischen Vereinigung and, 959  
 on therapeutic alliance, 1741  
 Vienna Ambulatorium and, 959  
 Wiener psychoanalytische Vereinigung and, 1857  
 on working-off mechanisms, 1877  
 Bibring-Lehner, Grete, **176–177**  
 on anxiety neurosis, 1137  
 Boston Psychoanalytic Society/Institute and, 207  
 Canadian psychoanalysis and, 242  
 Lehrinstitut der Wiener psychoanalytischen Vereinigung and, 959  
 on parenthood, 1237  
 photograph of, I:pl.9  
 Sterba and, 1659  
 Wiener psychoanalytische Vereinigung and, 1857  
 Bick, Esther, **177–178**  
 on adhesive identification, 24, 125, 419, 815, 1170  
 Anzieu and, 104, 178  
 on autistic capsule, 138  
 on body image, 197  
 on breastfeeding, 221  
 child analysis and, 1732  
 on disintegration anxieties, 418  
 on infant observation, 177, 178, 816, 817, 818–819  
 on infantile psychosis, 825  
 on prematurity, 1304  
 Schilder and, 1538  
 on self, 1567  
 on self-mutilation, 1573  
 on skin, 178, 221, 815, 1170, 1613  
 Tavistock Clinic and, 177, 1728  
 on tenderness, 1736  
 on transitional phenomena, 1794  
 Bicudo, Virginia, 214, 216, 217  
 Bidimensionality, 137  
 Big graph, 1031  
 Big Other, 53, 1202  
 Bigras, Élizabéth, 864  
 Bigras, Julien Joseph Normand, **178–179**, 245, 528, 864, 1623  
 Bilz, Rudolf, 1734  
 Binding/unbinding of the instincts, **179–180**  
 activity/passivity and, 17  
 adolescence and, 27  
 free energy/bound energy and, 617  
 fusion/defusion and, 658, 659  
 tics and, 1756  
 trauma and, 1801  
 Binét, Agnes, 766  
 Binet, Alfred, 89, 460, 769, 871  
 Binger, Carl, 43  
 Binion, Rudolf, 314  
 Binswanger, Herbert, 852  
 Binswanger, Ludwig, **180–182**, 638  
 “Anna O.” case and, 225, 1224  
 on epistemology, 1371  
*Évolution psychiatrique, L'* and, 532  
 Fédida and, 569  
 on German romanticism, 674  
 on Goethe, 686  
 Hirschfeld, Elfriede and, 747  
 Merleau-Ponty and, 1047  
 Minkowski and, 1057  
 on phenomenology, 1267  
 Swiss psychoanalysis and, 1702, 1703  
 Binswanger, Otto, 674, 678  
 Bioenergy, 272



## INDEX

Volume 1, pp. 1–662; Volume 2, pp. 663–1344; Volume 3, pp. 1345–1892

- Biolibidio* (Levi Bianchini), 963
- Biological bedrock, **182–183**, 254, 575, 773, 1278
- “Biological Economy of Birth, The” (Greenacre), 702
- Bion, Wilfred Ruprecht, **183–184**
- on alpha-elements, 50–51, 184, 815
- on alpha function, 51–52, 121, 184, 952, 953
- analytic psychodrama and, 78
- Anzieu and, 104
- Argentinian psychoanalysis and, 118
- on arrogance, 121
- on attacks on linking, 983–984
- on attention, 127–128, 439
- on autobiography, 140
- on basic assumption, 151, 709–710, 711
- on beta-elements, 171, 184
- on beta-screens, 171–172
- on binding/unbinding, 658
- on birth, 185
- on birth trauma, 1803
- on bizarre object, 188
- Bleger and, 194
- Brazilian psychoanalysis and, 217
- British psychoanalysis and, 699
- Canadian psychoanalysis and, 244
- on castration, 1676
- on castration complex, 254
- on catastrophic change, 257, 418
- on change, 268
- on common sense, 419
- on compulsion, 323
- on concepts, 323–324
- on contact-barrier, 339–340
- on container-contained, 184, 340, 850
- Corrao and, 347
- on death instinct, 373
- on deferred action, 380
- definition of psychoanalysis and, 1363
- on disintegration anxieties, 418
- on dream-like memory, 439
- on emotions, 501
- on envy, 508–509
- on fantasy, 551
- feminist views of psychoanalysis and, 577
- Foulkes and, 601
- on frame of psychoanalytic treatment, 606
- on grids, 704, 705, 1031
- on groups, 183, 184, 601, 709, 710–711, 713, 1371
- on hallucinatory, 722
- on hallucinosis, 722–723
- on hatred, 729
- on *infans* stage, 813
- on infant development, 815
- on infant observation, 817
- on infantile psychosis, 824–825, 826
- on intergenerational phenomena, 846
- on internal/external reality, 848
- on internal objects, 849, 850
- on invariant, 871–872
- Israeli psychoanalysis and, 878
- Italian psychoanalysis and, 879, 880, 881
- on lack of differentiation, 932
- Learning from Experience*, 50, 171, 339, 704, 952–953
- on logic, 990
- Los Angeles Psychoanalytic Society/Institute and, 992
- on Love-Hate-Knowledge links, 995–996
- Main and, 1003
- on maternal, 1028
- on memoirs of the future, 1039–1040
- Money-Kyrle and, 1070
- on nameless dread, 90
- on negative capability, 1123–1124
- on nonverbal communication, 1154
- on object, 1170
- on preconception, 1299–1300
- on primal, 1312
- on primary object, 1317
- on projective identification, 1336, 1339
- on protective shield, 1340
- on proto-thoughts, 1343
- psychology and psychoanalysis and, 1398
- on psychotic defenses, 1414
- on psychotic panic, 1416
- on psychotic part of the personality, 1416–1417
- on psychotic transference, 1419
- on puerperal psychoses, 1422
- Racamier and, 1436
- on realization, 1451–1452
- Rees and, 1457
- on relations model, 1464
- on representation, 551, 782
- on resistance, 1489
- on reverie, 5, 127–128, 184, 1030–1031, 1169, 1317
- Rickman and, 183, 1502
- Second World War and, 1558
- on selected facts, 1566–1567
- on self, 1568
- on sense/nonsense, 1585
- Simmel and, 1612
- on skin, 1613
- sociology and, 1632
- on splitting, 1646
- on splitting of the object, 1642
- Swedish psychoanalysis and, 1699
- on symbiosis, 1464, 1706
- on symbolic equation, 1709
- on symbolization, 1714
- Tavistock Clinic and, 1728
- on thought-thinking apparatus, 1749–1750
- on transformations, 1790
- Tustin and, 1809
- on vertex, 1833–1834
- on work of the negative, 1130
- Bios, Psyche, Person* (Caruso), 249
- Biosocial theory, 307
- Biotrauma, 90
- Bipolar self, **184–185**
- Biro, Elisabeth, 1686
- Birraux, Annie, 1275, 1276
- Birth, 185–186, **185**, 1747
- Birth dreams, **185–186**
- “Birth of Intellect, The” (Ferenczi), 1289
- Birth trauma, 641
- anaclitic depression and, 70
- asthma and, 124
- castration complex and, 253
- Laforge on, 933
- Rank on, 124, 253, 641, 833, 834, 1802–1803
- Bisexuality, **186–187**, 1635, 1752
- aggression and, 33
- female sexuality and, 365, 571
- femininity and, 573
- homosexuality and, 757
- masculinity/femininity and, 186–187, 1019
- object-choice and, 187, 1175
- parenthood and, 1237
- pregnancy fantasy and, 1302–1303
- rejection of femininity and, 575
- rivalry and, 1506
- sublimation and, 1679
- superego and, 1691
- symbolization and, 1714
- Weininger and, 1587–1588
- Biting, 6
- Bittencourt de Martins, Zaira, 215, 217, 248
- Bitter, Wilhelm, 677
- Bizarre object, **188**, 850, 851
- Bjerre, Poul, **188–189**, 1697
- Björk, Stig, 584
- Black holes, **189–190**, 218

Volume 1, pp. 1–662; Volume 2, pp. 663–1344; Volume 3, pp. 1345–1892

- Black Skin, White Masks* (Fanon), 549  
 Blacker, Kay Hill, 871  
 Blackett-Milner, Marion, **190–191**  
 Blackmail, 1686  
 Blanc, Claude, 314  
 Blanchot, Maurice, 241  
 Blank psychoses, **191–192**  
 Blankenburg, Wolfgang, 1267  
 Blanton, Smiley, **192–193**, 541, 835, 1729  
 “Blasphemy and the Punishment of Heaven” (Sterba), 1658  
 Blau, Abram, 1137  
 Blazevic, Duska, 1884  
 Bleger, José, **193–194**  
   Argentinian psychoanalysis and, 118, 193–194  
   on frame of psychoanalytic treatment, 606, 1405  
   on group psychotherapies, 713  
   on individual, 811  
   on psychoses, 1405  
 Bleuler, Paul Eugen, **194–195**  
   Abraham, Karl and, 5  
   on ambivalence, 56, 1220  
   on autism, 6, 136  
   Brill and, 227  
   Burghölzli Asylum and, 235  
   complexes and, 319  
   Czech psychoanalysis and, 360  
   on dementia, 389  
   Eitingon and, 492–493  
   *Évolution psychiatrique, L’* and, 532  
   free association and, 616  
   on Hirschfeld, Elfriede, 747  
   on infantile psychosis, 824, 825  
   International Psychoanalytical Association and, 854  
   *Jahrbuch für psychoanalytische und psychopathologische Forschungen* and, 884  
   Jung and, 1398, 1399  
   Lacan and, 37  
   Maeder and, 999  
   Minkowska-Brokman and, 1056  
   Minkowski and, 1057  
   Morgenstern-Kabatschnik and, 1073  
   *Nervous Anxiety States and their Treatment* and, 1132  
   Nunberg and, 1165  
   Oberholzer and, 1167  
   on paranoid psychosis, 1232  
   Pfister and, 1260  
   photograph of, I:pl.11  
   Piaget and, 1282  
   on psychoses, 191, 1403  
   Rorschach and, 1394, 1512–1513  
   Sarasin and, 1534  
   on schizophrenia, 195, 1234, 1540  
   on secondary narcissism, 1110  
   Spielrein and, 1639  
   on *Studies on Hysteria*, 1671  
   Swiss psychoanalysis and, 1702  
   Van Ophuijsen and, 1200  
   Winterstein and, 1863  
*Blind Alley* (film), 292  
 Blindness, psychogenic, 1392–1393  
 Blitzsten, N. Lionel, 277  
*Bloc, Le—Notes de la psychanalyse*, **195**  
 Bloch, Iwan, 674  
 Bloch, Jean-Richard, **195–196**, 1075  
 Blomfield, O. H. D., 131  
 Bloom, Harold, 987  
 Bloomsbury Group, 695, 708, 1662, 1663  
 Blos, Peter, **196–197**  
   on adolescence, 28, 196–197  
   German psychoanalysis and, 1060  
   Hietzing Schule and, 745  
   photograph of, I:pl.10  
 Blow, Susan, 1425  
 “Blue Book” (Quatrième Groupe), 603, 1430  
 Blum, Ernst, 1222, 1703  
 Blum, Harold P., 897, 1228, 1368, 1600, 1601  
 Blushing, fear of. *See* Erythrophobia  
 Boas, Franz, 1035, 1822  
 Body ego, 139, 479, 1571  
 Body image, **197–198**  
   Dolto-Marette on, 428  
   Schilder on, 1538  
   self-image and, 1571  
   tube-ego and, 1806  
 Body schema, 478, 1571  
 Boehm, Felix Julius, **198–199**  
   Abraham, Karl and, 5, 198  
   Berliner Psychoanalytische Poliklinik and, 164  
   Berliner Psychoanalytisches Institut and, 165, 198, 199  
   Deutsche Psychoanalytische Gesellschaft and, 675  
   Göring Institute and, 199, 406, 676, 689  
   Kemper, Werner Walther and, 910  
   Nazi Germany and, 164, 198, 199, 406, 675, 676, 689, 852  
   on phallic woman, 1264  
   Serbian psychoanalysis and, 1884  
   Sokolnicka-Kutner and, 198, 1633  
   Tomasi and, 1758  
 Bofill, P., 331  
 Bofill, Pedro, 1296  
 Bogner, Dieter, 136  
 Bohleber, Werner, 1602  
 Bohomolec, Elzbieta, 1292  
 Bokanowski, Thierry, 1499, 1781–1782  
 Bolk, Ludwig, 1510  
 Bollas, Christopher, 914, 1170–1171, 1580  
 Bölsche, Wilhelm, 1197  
 Bonaparte, Marie Léon, **199–201**  
   on autobiography, 140  
 Belgian psychoanalysis and, 157  
 Berman and, 166  
 Bernays-Freud, Minna and, 168  
 Cárcamo and, 247  
 Congrès des psychanalystes de langue française des pays romans and, 329  
 Dubal and, 450  
 Eitingon and, 493  
 Fliess correspondence and, 642  
 Flournoy, Henri and, 591  
 Freud, Anna and, 619  
*Gesammelte Werke* and, 680  
 Greek psychoanalysis and, 700, 922, 1885  
 Guilbert and, 716  
 Hesnard and, 742  
 Hungarian psychoanalysis and, 765  
 Imago Publishing Company and, 802  
 Internationaler Psychoanalytischer Verlag and, 862  
 Janet and, 886  
 Laurent-Lucas-Championnière-Maugé and, 948  
 Le Bon and, 953  
 Loewenstein and, 291, 989  
 multilingualism and, 1086  
 Nazi Germany and, 681, 893  
 Pichon and, 1283  
   on Poe, 200, 974–975  
   primal scene and, 1310  
*Psyché* and, 1350  
*Psychoanalytic Study of the Child, The* and, 1381  
*Revue française de psychanalyse* and, 200, 934, 988, 1497, 1498, 1499  
*Rivista di psicoanalisi* and, 1508  
 Róheim and, 1510  
 Schilder and, 1538  
 Sechehaye and, 1557  
 Second World War and, 1557  
 Servadio and, 1586

## INDEX

Volume 1, pp. 1–662; Volume 2, pp. 663–1344; Volume 3, pp. 1345–1892

- Sigmund Freud: Life and Work* and, 974  
 Société psychanalytique de Paris and, 199–200, 608, 988, 1623, 1624, 1626, 1629, 1630  
 Sokolnicka-Kutner and, 1634  
 surrealism and, 1696  
 Tegel clinic and, 1734  
 translations by, 887  
*Zeitschrift für psychoanalytische Pädagogik* and, 1886  
 Bondiek, Erika, Chilean psychoanalysis and, 284, 285  
*Bonds of Love* (Benjamin), 577  
 Bondy, Theresa, 361  
 Bonhoeffer, Karl, 646, 665, 1085  
 Bonnafé, Lucien, 1765  
 Bonnafé, Marie, 411  
*Book of the It, The* (Groddeck), **201–202**, 706, 777  
 Borch-Jacobsen, Mikkel, 89, 225, 1224  
 Borderline conditions, **202–203**  
 abandonment and, 2  
 archaic mother and, 113  
 “as if” personality and, 122, 202  
 attacks on linking and, 983  
 basic fault and, 152  
 blank psychoses and, 191, 192  
 character and, 270  
 consciousness and, 334  
 dependence and, 392  
 ego interests and, 484  
 narcissistic injury and, 1113  
 narcissistic neuroses and, 1114  
 narcissistic withdrawal and, 1117  
 pain and, 1220  
 paranoid-schizoid position and, 1233  
 passage to the act and, 19  
 protective shield and, 1341–1342  
 psychic structure and, 1359  
 psychoanalytic nosography and, 1375  
 schizophrenia and, 1540  
 skin-ego and, 1613–1614  
 “Wolf Man” case and, 649  
 work of the negative and, 1130  
*Borderline Conditions and Pathological Narcissism* (Kernberg), 191  
 Boredom, **203–204**, 1757  
 Borel, Adrien Alphonse Alcide, **204–205**  
 Cénac and, 261  
 Claude and, 305  
 Congrès des psychanalystes de langue française des pays romans and, 329, 608  
 French psychoanalysis and, 608  
 Pichon and, 1283  
 Société psychanalytique de Paris and, 1623  
 surrealism and, 1696  
 Borighieri, Paolo, 1199  
 Börne, Ludwig, 356, 616  
 Bornstein, Berta, **205–206**  
 Lehrinstitut der Wiener psychoanalytischen Vereinigung and, 959  
 New York Psychoanalytic Institute/Society and, 1148  
 photograph of, I:pl.12  
 primary identification and, 1314  
 Bornstein, Steffi, 205, 360  
 Bornsztajn, Maurycy, 1292  
 Borowiecki, Stefan, 1292  
 Borromean knot, 916, 917, 1454  
 object *a* and, 1173  
 philosophy and, 1270, 1271  
 structural theories and, 1667  
 subject and, 1673  
 symptoms and, 1718–1719  
 topology and, 1761, 1763–1764  
 Borsoi, Gerson, 215  
 Bose, Girindrasekhar, **206**, 807, 808  
 Boss, Médard, 181, 852, 1703  
 Bossé, Jean, 245, 1621–1622  
 Bosseret, Marguerite, 449  
 Boston Psychoanalytic Society, 1523  
 Boston Psychoanalytic Society/Institute, **206–209**, 1087, 1425, 1444, 1860, 1888  
 Boszormenyi-Nagy, Ivan, 845  
 Botella, César, 722, 1116, 1867  
 Botella, Sára, 722, 1116, 1867  
 Botero, Fernando, 1618  
 Bottle feeding, 222  
 Bouasse, Henri, 1201  
 Boucebcı, Mahfoud, 1155  
 Boucourechliev, André, 1628  
 Boulanger, Françoise, 243, 1623  
 Boulanger, Jean-Baptiste, 243, 245  
 Bound energy. *See* Free energy/bound energy  
 Boundary violations, **209–210**  
 Bourdier, Pierre, 610, 1004  
 Bourgeois, Héliane, 1014  
 Bourget, Paul, 1634  
 Bourguignon, André, 124  
 Bousquet, Joë, 37, 1014  
 Boutonier, Juliette. *See* Favez-Boutonier, Juliette  
 Bouveresse, Jacques, 1271  
 Bouvet, Maurice, 1626  
 Bouvet, Maurice Charles Marie Germain, **210–211**  
 allergic object relationship and, 47  
 Chertok and, 277  
 Choisy and, 290  
 Congrès des psychanalystes de langue française des pays romans and, 331  
 on depersonalization, 393  
 on ego, 467  
 French psychoanalysis and, 609, 610  
 Granoff and, 692  
 Marty and, 211, 1016  
 on neurotic defenses, 1142  
 on object relations, 1170  
 Parcheminey and, 210, 1236  
 Perrier and, 211, 1251  
 on psychic structure, 1359  
 on psychoanalytic treatment, 1385  
 Videman and, 1835  
 Boven, William, 1620  
 Bovet, Lucien, 1442  
 Bovet, Pierre, 116, 1282, 1620  
 Bowlby, Edward John Mostyn, **211–212**  
 on abandonment, 2  
 on *amae*, 56  
 anaclitic depression and, 70, 71  
 on aphanisis, 105–106  
 on attachment, 125, 126, 814–815, 821–822  
 Aubry Weiss and, 129  
 Bick and, 177  
 on Brierley, 226  
 British psychoanalysis and, 697, 699  
 child analysis and, 1732  
 on clinging instinct, 307, 737  
 on developmental processes, 1330  
 ethology and, 528  
 on experience of satisfaction, 537  
 on individual, 811  
 on infant development, 814  
 on infant observation, 817, 818  
 on infantile depression, 71  
 Laing and, 937  
 Lebovici and, 955  
 on maternal care, 1028, 1029  
 on narcissism, 97  
 on primary need, 1316  
*Psychoanalytic Study of the Child, The* and, 1382  
 Riviere-Hodgson Verrall and, 1507  
 Robertson and, 1509  
 on social feeling, 1618  
 on stranger anxiety, 1664

Volume 1, pp. 1–662; Volume 2, pp. 663–1344; Volume 3, pp. 1345–1892

- on sucking, 1682  
 Suttie and, 1457  
 Tavistock Clinic and, 1728  
 on tenderness, 1736  
 Tustin and, 1809  
 BPI. *See* Berliner Psychoanalytisches Institut  
 BPS. *See* British Psycho-Analytical Society  
 Braatøy, Trygve, 1157–1158  
 Braconnier, Alain, 27  
 Bradley, Charles, 824  
 Braid, James, 768, 973, 1684, 1774  
 Brain, 212–213, 389, 1054, 1065  
 Brandao, Teixeira, 614  
 Brandchaft, Bernard, 1307  
 Brandell, Gunnar, 1699  
 Brandschaft, Bernard, 1568  
 Braun, Heinrich, 1609, 1836  
 Braunschweig, Denise  
 on censoring the lover in her, 262, 1174  
*Confrontation* and, 327  
 on hallucinatory wish-fulfillment, 1867  
 on object, 1170  
*Revue française de psychanalyse* and, 1499  
 on typical dreams, 1811  
 Brazelton, T. Barry, 454, 955, 1304, 1382  
 Brazilian psychoanalysis, 213–218  
 Enriquez-Joly and, 507  
 Franco da Rocha and, 614  
 International Psychoanalytical Association  
 and, 214, 216, 858, 955, 1012  
 Kemper, Werner Walther and, 214, 215,  
 217, 910–911  
 Koch and, 919  
 Marcondes and, 214, 215, 216, 217, 919,  
 1012–1013  
 Perestrello, Danilo and, 214, 215, 216, 1250  
 Porto-Carrero and, 214, 1295  
 Brazilian psychoanalytic society. *See*  
 Sociedade brasileira de psicanálise  
 Breakdown, 218, 1420  
 Breast  
 absence of, 323–324, 1749–1750  
 claustrophobia and, 306  
 dream screen and, 440–441  
 encounter and, 505  
 Isakower phenomenon and, 440, 441, 875  
 love and, 994  
 maternal and, 1027–1028  
 object *a* and, 1173  
 object loss and, 993–994  
 oral stage and, 1204  
 privation and, 1326, 1327  
 sexuality and, 1594  
 social feeling and, 1618  
 subject's castration and, 1676  
 sucking and, 1682  
 transitional phenomena and, 1794, 1795  
*See also* Breast as good/bad object;  
 Breastfeeding  
 Breast as good/bad object, 218–220  
 anxiety and, 100  
 archaic mother and, 112, 113  
 beta-elements and, 171  
 concepts and, 323–324  
 disintegration anxieties and, 418  
 orality and, 1203, 1204  
 pictogram and, 1286  
 splitting of the object and, 1642  
 Breastfeeding, 220–222  
 anaclysis and, 68, 69  
 black holes and, 189  
 mourning and, 29  
*See also* Sucking  
 Brecht, Karen, 679  
 Breen, Dana, 577  
 Bregant, Leopold, 1884  
 Brenman-Pick, Irma, 1338  
 Brenner, Charles, 119, 487, 897, 1148  
 Brentano, Franz von, 222–223, 636, 1838  
 internal/external reality and, 847  
 philosophy and, 1268  
 on self-consciousness, 1569  
 Silberstein and, 1609  
 Breton, André, 223–224  
 on Claude, 305  
 Embirikos and, 498  
 French psychoanalysis and, 607  
 Held and, 731  
 Lacan and, 37  
 Martinican psychoanalysis and, 1014  
 surrealism and, 1695–1696  
 Brette, Françoise, 1631  
 Breuer, Josef, 224–226  
 on adolescence, 26  
 on aggression, 33  
 on “Anna O.” case, 87, 1223  
 on autosuggestion, 144  
 “Cäcilie M.” case and, 239  
 cathartic method and, 257–258, 1384  
 on change, 267  
 Charcot and, 1529  
 on complexes, 319, 320  
 on conflict, 325  
 on constancy principle, 1322  
 contact and, 338  
 on daydreams, 555, 1493  
 on dreams, 436  
 “Emmy von N.” case and, 500  
 on facilitation, 543  
 free energy/bound energy and, 617  
 Freud's autobiography and, 139  
 Freud's friendship with, 637, 638  
 on hypnoid states, 768  
 on hypnosis, 769  
 on indications/contraindications for  
 psychoanalysis, 808–809  
 on masochism, 33  
 on neuroses, 287  
 photograph of, I:pl.13  
 on primary/secondary processes, 1318  
 on psychic energy, 1355  
 on remembering, 1467  
 on reminiscences, 1470–1471  
 on repression, 1482  
 on splitting, 1646  
 Swedish psychoanalysis and, 1697  
 transference relationship and, 1787  
 on trauma, 1800  
 on unpleasure, 1826  
 Vienna General Hospital and, 1837  
*See also* *Studies on Hysteria*  
 Bria, Pietro, 1816  
 Briand, Aristide, 204, 953  
 Briceña, Antonio, 1832  
 Bridger, Harold, 601, 1003, 1728  
 Brief, Otta, 361  
 “Brief Notion of Psychoanalysis, A” (Porto-  
 Carrero), 1295  
 Brierley, Marjorie Flowers, 226–227  
 Controversial Discussions and, 226, 343,  
 344, 697  
 feminist views of psychoanalysis and, 577  
 Glover, James and, 685, 696  
 Klein and, 697  
*Brigands* (Schiller), 1539  
 Bril, Blandine, 1775  
 Bril, Jacques, 349  
 Brill, Abraham Arden, 227–228  
 American Psychoanalytic Association and,  
 227, 1823  
 Burghölzli Asylum and, 227, 236  
 Freud U.S. visit and, I:pl.16, 207, 303,  
 587, 1822  
 Frink and, 648, 649  
 Internationaler Psychoanalytischer Verlag  
 and, 862  
 Jelliffe and, 1379  
 Jones and, 892

## INDEX

Volume 1, pp. 1–662; Volume 2, pp. 663–1344; Volume 3, pp. 1345–1892

- Kardiner and, 906  
 on lay analysis, 951, 1432  
 Lehrman and, 960  
 Lorand and, 991  
 Nazi Germany and, 893  
 New York Psychoanalytic Society and, 227, 1147  
 photographs of, I:pl.14,16  
 Rank and, 1445  
*Standard Edition* and, 1655  
 Sullivan and, 1688  
 Swiss psychoanalysis and, 1702  
*Bringing Up Baby* (film), 292  
 Brisset, Charles, Ey and, 540  
 British Confederation of Psychotherapists, 698  
 British Independent Group, Fairbairn and, 546  
 British Institute of Psycho-Analysis, Canadian psychoanalysis and, 1621  
 British Psycho-Analytical Society (BPS), 228–230, 698  
 Australian psychoanalysis and, 132  
 Bowlby and, 212  
 Brazilian psychoanalysis and, 214, 215  
 Brierley and, 226  
 Canadian psychoanalysis and, 242–243  
 Eder and, 461  
 Fairbairn and, 545  
 feminist views of psychoanalysis and, 577  
 Flügel and, 593–594  
 Freud, Anna and, 212, 228, 229, 619, 1245  
 Friedländer-Fränk and, 646  
 Glover, Edward and, 229, 343, 344, 684, 697  
 Glover, James and, 685  
 Heimann and, 730  
 Hellman Noach and, 733  
 Hoffer and, 752, 753  
 infant observation and, 818  
*International Journal of Psychoanalysis, The* and, 853  
 International Psychoanalytical Association and, 856  
 Isaacs-Sutherland and, 873  
 Jones and, 892  
 Khan and, 913–914  
 Klein and, 510, 619, 914–915  
 Limentani and, 230, 978  
 Low and, 997  
 Payne and, 228, 343, 344, 1245  
 Rickman and, 1501, 1502  
 Riviere-Hodgson Verrall and, 1507  
 Rosenfeld, Herbert and, 1514  
 Rycroft and, 1521  
 Sandler and, 1533  
 Schmideberg-Klein and, 1542  
 Sharpe and, 1599  
 Strachey and, 1662  
 Strachey-Sargent and, 1663, 1664  
 Winnicott and, 1861  
*See also* Controversial Discussions  
 British psychoanalysis, 695–700  
 child analysis and, 279, 697–698  
 Controversial Discussions and, 343, 697  
*See also* British Psycho-Analytical Society (BPS); British school; Controversial Discussions  
 British school, 183, 278, 1336  
 Broca, Paul, 106, 212, 1042  
 Brod, Max, 708  
 Brodeur, Claude, 1622  
 Broglie, Louis de, 1350  
 Bromberg, Walter, 41  
 Brookes, R. A., 131  
*Brothers Karamazov, The* (Dostoyevsky), 23, 985  
 Brouillet, André, 275  
 Brown, N., 294  
 Brown, Norman, 1632  
 Browne, William, 696  
 Browne, William J., 413  
 Brücke, Ernst Wilhelm von, 230–231, 637, 1550, 1837, 1838  
 Freud's autobiography and, 139  
 German romanticism and, 673  
*Interpretation of Dreams, The* and, 866  
 psychology and psychoanalysis and, 1397  
 Brudny, Guillermo, 285  
 Bruhl, Cramer, C. von, 412  
 Brun, Rudolf, 231–232, 1549, 1703  
 Bruner, Jerome, 1153  
 Bruno, Giordano, 1243  
 Bruno de Jésus-Marie, Father, 156, 934  
 Brunswick, David, 1529  
 Brunswick, Mark, 232  
 Brunswick, Ruth Mack, 232–233  
 on female sexuality, 571, 1186  
 Gardiner and, 664  
 on phallic woman, 1264  
 Schur and, 232, 233, 1548  
 “Wolf Man” case and, 233, 649, 1221  
 Brunswick Square Clinic, 684, 685, 695  
 Brusset, Bernard, 234, 830, 1406, 1407  
 Brusset, Bruno, 1652  
 Brut, Cyril, 1883  
 Bryan, Douglas, 593, 1664  
 Bryher (Winifred Ellerman), 430  
 Buber, Martin, 999  
*Bubi Caligula* (Sachs), 1523  
 Buchmann, Frank, 999  
 Budapest School. *See* Hungarian School  
*Buddenbrooks* (Mann), 1008  
 Buddhism, 39, 922, 1096  
 Buder, Hildegard, 677  
 Buhler, Charlotte, 177, 733  
 Bühler, Karl, 172  
 Bulemia, 1578  
 Bulimia, 91, 233–234, 413  
 Bullard, Dexter, 1688, 1850  
 Bullard, Dexter M., Sr., 652  
*Bulletin de la Fédération européenne de psychanalyse*, 530  
*Bulletin de la S.P.P.*, 1629  
 Bullitt, William C., 234–235, 608, 641, 681, 1293  
*See also* Thomas Woodrow Wilson, *Twenty-eighth President of the United States. A Psychological Study*  
 Buñuel, Luis, 294, 1067, 1695  
 Burghölzli Asylum, 235–236  
 Binswanger and, 180  
 Brill and, 227  
 Eitingon and, 493  
 Gross and, 607  
 Jung and, 180, 235, 236, 901–902, 1399  
 Lacan and, 929  
 Rittmeister and, 1505  
 schizophrenia and, 1540  
 Sechehaye and, 1557  
 Sokolnicka-Kutner and, 1633  
 Spielrein and, 1639  
 Swiss psychoanalysis and, 1702  
 word association and, 1872  
 Burgner, Marion, 577  
 Burian, Wilhelm, 133, 1859  
 Burke, Mark, 214–215, 910  
 Burlingham-Rosenfeld School. *See* Hietzing Schule  
 Burlingham-Tiffany, Dorothy, 236–237  
 on abandonment, 2  
 Aichhorn and, 36  
 Berggasse 19, Wien IX and, 163  
 Blos and, 196  
 Controversial Discussions and, 343  
 Freud, Anna and, 619, 1514  
 Hampstead Clinic and, 724  
 Hietzing Schule and, 510, 745, 1513  
 Imago Publishing Company and, 802

Volume 1, pp. 1–662; Volume 2, pp. 663–1344; Volume 3, pp. 1345–1892

- on infantile depression, 70–71  
 on latent dream thoughts, 947  
 Lehrinstitut der Wiener  
 psychoanalytischen Vereinigung and, 959  
 Lehrman and, 960  
 Tegel clinic and, 1734  
*Zeitschrift für psychoanalytische Pädagogik*  
 and, 1886  
 Burnhan, Donald L., 1850  
 Burning child dream, 1677  
 Burrow, Trigant, **237–238**, 601, 709, 713  
 Burt, Sir Cyril, 696  
 Buxbaum, Edith, 959  
 Bychowski, Gustav, 1292  
 Bydlowski, Monique, 1297, 1298, 1864
- C**
- Cabanis, Pierre, 795  
 Cabernite, Leão, 216  
*Cabinet of Dr. Caligari, The* (film), 292, 293  
 “Cécilie M.” case, **239–240**  
*Cadernos de psicanálise*, 217  
*Cadernos do Tempo psicanalítico*, 217  
*Caesura* (Bion), 185  
 Cahen, Michèle, 1465  
*Cahiers Confrontation, Les*, **240–241**  
*Cahiers du Centre Alfred-Binet, Les*, 411  
*Cahiers du Cinéma*, 295  
*Cahiers Jungiens de Psychanalyse*, 80  
*Cahiers pour l'analyse*, 611  
 Cahn, Raymond, 27, 806, 1627, 1674  
 Caillaux, Girard de, 1528  
 Caillot, Jean-Pierre, 1226  
 Caïn, Jacques, 1628  
 California Psychoanalytic Society,  
 1529, 1530  
 Callier, Jean, 934  
 Camacho, José, 1052  
 Camara, Domicio A., 910  
 Cameron, Ewen, 242, 243  
 Campos, Claudio de, 216  
 Campos, Murilo de, 214  
 Canadian Institute of Psychoanalysis, 243  
*Canadian Journal of Psychoanalysis/Revue  
 canadienne de psychanalyse*, 245  
 Canadian psychoanalysis, **241–246**, 864,  
 1620–1623  
 Canadian Psychoanalytic Society (CPS),  
 241–242, 243–244, 1620–1623  
 Cancerophobia, 1717  
 Canguilhem, Georges, 401  
 Cannibalistic stage. *See* Incorporation; Oral-  
 sadistic stage  
 Cannon, Walter Bradford, 1323
- Capacity to be alone, 3, **246–247**  
 Capgras, J., 381  
 Capgras, Joseph, 1136  
 Capitalism, 45, 98, 1632  
*Capitalisme et Sexualité* (Capitalism and  
 sexuality) (Allendy & Allendy-nel-  
 Dumouchel), 45, 46  
 Cárcamo, Celes Ernesto, 55, 117, **247–248**,  
 665, 1284  
*Carefree* (film), 292  
 Caretaker self, 1582  
 Carl Gustav Jung Institute/Zürich, 80  
 Carloni, Glauco, 881  
 Carnap, Rudolf, 980  
 Carneiro Leão Vetter, Inaura, 215  
 Carpelan, Henrik, 584  
 Carpenter, William, 768  
 Cartels constituants de l'analyse Freudienne,  
 612, 1083, 1084  
 Caruso, Igor A., **248–249**  
 Austrian psychoanalysis and, 134–135  
 Frankl and, 615  
 International Federation of Psychoanalytic  
 Societies and, 852  
*Psyché* and, 1350  
 Carvajal, Guillermo, 566, 567  
 “Cas de Mme Lefebvre, Le”  
 (Bonaparte), 200  
*Cas de psychose infantile, Un* (McDougall  
 and Lebovici), 828, 955  
 Casas de Peredo, Myrta, 1829  
 Casaula, Eleonora, 285  
 Case histories, **249–251**  
*See also specific cases*  
 “Case of Examination Neurosis, A” (Alvarez  
 de Toledo), 55  
 “Case of Paranoia Running Counter to the  
 Psycho-Analytic Theory of the Disease, A”  
 (Freud), 848, 1234, 1307  
 “Case of Psychogenic Mutism, A”  
 (Morgenstern-Kabatschnik), 1073  
 “Case of Psychogenous Muteness, A”  
 (Morgenstern), 1610  
*Case of Sergeant Grischa, The* (Zweig), 1889  
 “Case of Successful Treatment by  
 Hypnotism, A” (Freud), 220, 341, 448, 1560  
 Caslant, E., 400  
 Cassel Hospital, 230, 700, 1003  
 Cassirer, Ernst, 198, 785, 1119  
 Cassirer-Bernfeld, Suzanne, 974  
 Castel, Pierre-Henri, 401, 1217  
 Castoriadis, Cornelius, 1632  
 Castoriadis-Aulagnier, Piera. *See* Aulagnier-  
 Spairani, Piera
- Castration, primal, 1678  
 Castration anxiety, 251, 253  
 abandonment and, 2  
 biological bedrock and, 182, 254, 773  
 birth dreams and, 186  
 Bose on, 206  
 claustrophobia and, 306  
 dark continent metaphor and, 365  
 dead mother complex and, 369  
 death and, 370  
 fantasy and, 552, 553  
 fetishism and, 582  
 fragmentation anxiety and, 100, 605  
 Haitzmann case and, 1587  
 identification and, 789  
 inferiority feelings and, 831  
 Oedipus complex and, 1185  
 overview of, 101  
 perversion and, 1256  
 phallic mother and, 1261, 1262  
 phobias and, 1274, 1275  
 phobic neurosis and, 1276  
 privation and, 1326–1327  
 sadomasochism and, 1527  
 stammering and, 1653  
 “vagina dentata” fantasy and, 1831  
 Castration complex, **251–256**, 1635  
 Abraham, Nicolas on, 7  
 aphanisis and, 105  
 cinema and, 295  
 disavowal and, 416  
 disintegration anxieties and, 418  
 female sexuality and, 570, 573  
 frustration and, 653  
 gaze and, 990  
 genital stage and, 672  
 “Little Hans” case and, 76, 251, 253, 254  
 penis envy and, 252, 253, 254, 1246  
 phallic stage and, 1262–1263  
 primary narcissism and, 1110  
 self-mutilation and, 1572  
 self psychology on, 1576  
 sexual theories of children and, 1591  
 sexuation and, 1595, 1596  
 splitting of the ego and, 1648  
 subject and, 1676–1677  
 subject's castration and, 1676, 1677  
 superego and, 1691  
 symbolic and, 1711  
 symptoms and, 1717, 1718  
 topology and, 1761  
 Weininger and, 1588

## INDEX

Volume 1, pp. 1–662; Volume 2, pp. 663–1344; Volume 3, pp. 1345–1892

- “Wolf Man” case and, 252, 253, 650  
 Castro, Elena, 285  
 Catastrophe theory, **256–257**, 1665  
 Catastrophic change, **257**, 418  
 Catharsis, 78, 294  
   *See also* Cathartic method  
 Cathartic method, **257–259**, 1384, 1411  
   active technique and, 15  
   “Anna O.” case and, 87–89, 225, 257–258  
   change and, 267  
   cinema on, 1562, 1563  
   conversion and, 345  
   “Emmy von N.” case and, 499  
   remembering and, 1467  
 Cathectic energy, **259**  
 Cathexis, **259–261**, 1663  
   attention and, 127  
   autoeroticism and, 141  
   cathectic energy and, 259  
   change and, 267  
   conflict and, 326  
   death instinct and, 371  
   decathexis and, 373–374  
   displacement and, 421  
   ego and, 464  
   ego-instincts and, 483  
   family and, 548  
   free energy/bound energy and, 617  
   identification and, 788  
   infantile sexual curiosity and, 829  
   melancholia and, 21, 1038  
   narcissism and, 1105  
   primary identification and, 1313  
   representation and, 782  
   rituals and, 1504  
   somasochism and, 1527  
   self-esteem and, 1570  
   self-mutilation and, 1573  
   self-object and, 1575  
   sense/nonsense and, 1585  
   sexual theories of children and, 1590  
   sexualization and, 398  
   skin and, 1613  
   sleep/wakefulness and, 1614  
   somatic compliance and, 1635  
   somniaambulism and, 1636  
   stages and, 1652  
   stammering and, 1653, 1654  
   subject’s desire and, 1677  
   sum of excitation and, 1689  
   superego and, 1690, 1691  
   symbiosis and, 1705  
   symbolization and, 1713  
   thought and, 1746  
   transference and, 1776, 1777  
   turning around and, 1807  
   *See also* Anticathexes; Hypercathexis  
 Catholicism  
   Austrian psychoanalysis and, 134  
   basic assumptions and, 711  
   Beirnaert and, 156  
   Choisy and, 290  
   Delgado and, 385  
   Filipino psychoanalysis and, 1268  
   Italian psychoanalysis and, 879  
   jouissance and, 895–896  
   Lacan and, 611  
   Nodet and, 1152, 1153  
   Pichon and, 1283  
   *See also* Religion  
 Catoire, Gilles, 1731, 1783  
 Cauldwell, D. O., 1799  
*Causalité psychique, La* (Green), 1355  
 Causality, 1720  
 Causality, need for. *See* Need for causality  
 “Ce que tout médecin doit savoir de la psychanalyse” (Cénac), 261  
*Ce sexe qui n’en est pas un* (Irigaray), 578  
 CEFFRAP (Centre d’études françaises pour la formation et la recherche active en psychologie), 104  
 Célérier, Marie-Claire, 233  
*Céleste et le Sublunaire, Le* (Viderman), 1835  
*Célibataire, Le*, 1084  
 Cénac, Michel, **261–262**  
   Aubry Weiss and, 128  
   Centre de diagnostic et de traitements psychanalytiques and, 609  
   Claude and, 305  
   Lacan and, 929  
   Loewenstein and, 989  
   Parcheminey and, 1236  
   Société psychanalytique de Paris and, 261, 1630  
 Cendrars, Blaise, 45, 708  
 Censoring the lover in her, **262**, 1174  
 Censorship, **262–263**, 1677  
   analytic psychodrama and, 78  
   condensation and, 325  
   consciousness and, 333  
   day’s residues and, 367  
   displacement and, 421  
   dreams and, 262, 437, 438, 442, 1559  
   ego and, 464  
   fundamental rule and, 655  
   mentalization and, 1046  
   punishment dreams and, 1422  
   reversal into the opposite and, 1495  
   self-punishment and, 1577  
   symptoms and, 1715  
 Center for Psychoanalytic Training and Research. *See* Centre de consultations et de traitements psychanalytiques Jean-Favreau  
 Central masturbatory fantasy, adolescence and, 27, 29  
 Centre Alfred-Binet, 263, **263–264**, 410, 911, 955  
 Centre Claude Bernard. *See* Centre psychopédagogique Claude-Bernard  
 Centre de consultations et de traitements psychanalytiques Jean-Favreau (CCTP), **264–265**, 562, 1627, 1630, 1645  
 Centre de diagnostic et de traitements psychanalytiques, 609  
 Centre de formation et de recherches psychanalytiques (CFRP), 612, 1009, 1010, 1084  
 Centre d’étude des sciences de l’homme, 609  
 Centre d’études et de recherches freudiennes (CERF), 1083  
 Centre Étienne-Marcel, 347, 427, 428  
 Centre Jean-Favreau, 1630  
 Centre Psychoanalytique Raymond-de-Saussure, 1536, 1701  
 Centre psychopédagogique Claude-Bernard, **265**  
   Berge and, 161, 265, 559, 560, 609  
   Clark-Williams and, 303, 304  
   Favez-Boutonier and, 265, 559, 609  
   French psychoanalysis and, 609  
   Kestemberg-Hassin and, 911  
 Cercle Freudien, 612, 1084  
 CERF (Centre d’études et de recherches freudiennes), 1083  
 Certainty, **265–266**  
 Certeau, Michel de, 195, 241, **266–267**  
 Césaire, Aimé, 1009, 1014  
 Cesar de Castro, João, 214  
 Cesarman, Fernando, 566, 1051, 1052  
 Cesio, Fidas, 118  
 CFRP. *See* Centre de formation et de recherches psychanalytiques  
 Chabane, Mohand, 1156  
 Chabert, Catherine, 1394  
 Chadwick, Mary, 430, 684, 685, 696, 1886  
 Chaeva, Svetlana, 1520  
 Chaigneau, Hélène, 1765–1766  
*Chaînes d’Éros, Les* (Green), 1174  
 Chamberlain, Houston Stewart, 1437

Volume 1, pp. 1–662; Volume 2, pp. 663–1344; Volume 3, pp. 1345–1892

- Champ Freudien, Le, 611, 1010  
 Chance, 1720  
 Change, **267–269**  
   catastrophic, 257, 418  
   cure and, 358–359  
 Chaos theory, 401  
 Character, **269–271**, **272–273**, 1449  
 Character analysis, 1729  
*Character Analysis* (Reich), **271**, 1461  
 “Character and Anal Eroticism” (Freud), 72, 269, 272, 514, 516–517  
 Character neurosis, 48, 270, **273–274**, 557  
 Character resistance, 487  
 Charcot, Jean Martin, **274–276**, 637  
   Andersson on, 82  
   “Anna O.” case and, 88  
   on aphasia, 106  
   on autosuggestion, 144  
   Bernheim and, 170  
   Binet and, 89  
   “Cäcilie M.” case and, 239  
   cathartic method and, 225  
   on dreams, 436  
   Ellenberger on, 497  
   on erotogenicity, 520  
   French psychoanalysis and, 607  
   Freud’s autobiography and, 139  
   Freud’s translation, 403  
   on gaze, 990  
   on heredity of acquired characters, 736  
   on homosexuality, 757  
   on hypnosis, 768, 769  
   on hysteria, 772, 1529  
   on hysterical paralysis, 774  
   Janet and, 885  
   Meyer and, 1052  
   on neuroses, 287, 735  
   photograph of, I:pl.15  
   on psychic causality, 1353  
   Salpêtrière Hospital and, 275, 1527–1528  
   on suggestion, 1684–1685  
   Swedish psychoanalysis and, 1697  
   on trauma, 1800, 1801  
   on traumatic neuroses, 1471  
   U.S. psychoanalysis and, 1822  
   on working over, 1878  
 Chasseguet-Smirgel, Janine  
   on ego ideal, 480  
   on female sexuality, 365, 574  
   feminist views of psychoanalysis and, 576, 578  
   on homosexuality, 757  
   on idealization, 784  
   Schlumberger and, 1542  
   on self-esteem, 1570  
   Société psychanalytique de Paris and, 1626  
   on student protests (1968), 612  
 Chateaubriand, François-René, 203, 795  
 Chaurand, André, 1765  
 Chebel, Malek, 1156  
 Chemistry, 726  
 Chémouni, Jacquy, 900  
 Chentrier, Théodore, 242, 243, **276**  
 Cherkaoui, Leila, 1155  
 Chertok, Léon, **276–277**  
 Chertok, Leon, 1519  
 Chessman, Caryl, 200, 1499  
 Chestnut Lodge, 1540, 1688, 1850  
 Chicago Psychoanalytic Institute, 43, **277–279**  
   Bettelheim and, 173  
   Kohut and, 919–920  
   Los Angeles Psychoanalytic Society/Institute and, 992  
   U.S. psychoanalysis, 1823  
 Chicago Psychoanalytic Society, 43, 278, 279, 492  
*Chien andalou, Un* (film), 294  
*Child, His “Illness,” and the Others, The* (Mannoni), 456  
 Child analysis, **279–280**  
   Aubry Weiss and, 128–129  
   Bornstein on, 205  
   British psychoanalysis and, 279, 697–698  
   counter-transference and, 350, 1733, 1784  
   developmental disorders and, 408–409  
   developmental processes and, 1330  
   Diatkine and, 280, 411, 610, 613, 955, 1731, 1732  
   Diatkine on, 280, 411, 610, 613, 955  
   Dolto-Marette and, 280, 427–428, 592–593, 610, 1347, 1732  
   Erikson and, 510–511  
   Favreau and, 610  
   Favreau on, 562, 610  
   French psychoanalysis and, 610, 613  
   Freud, Anna and, 76, 279, 618–619, 697, 1386–1387, 1731–1732, 1733, 1783  
   Heuyer on, 744  
   Hug-Hellmuth and, 279, 283, 761–762, 1731  
   *Journal de la psychanalyse de l’enfant* and, 896  
   Katan-Rosenberg and, 908  
   Klein and, 76, 279, 280, 283, 618–619, 697–698, 915, 1366, 1731–1732, 1733  
   Lampl-de Groot and, 938  
   Lebovici and, 280, 610, 613, 955, 1732, 1784  
   “Little Hans” case and, 75–76, 279–280, 690, 1366, 1783  
   Moreno and, 1072  
   Morgenstern-Kabatschnik and, 280, 1073  
   Peraldi and, 1247  
   play in, 281, 283  
   prepsychosis and, 1306  
   puberty and, 1420  
   Rambert and, 1442–1443  
   “Richard” case and, 1500–1501  
   silence and, 1610  
   Sterba-Radanowicz-Hartmann, Editha and, 1658  
   technique in, **1731–1734**  
   transference and, 279, 1386–1387, 1732, 1733, 1782–1784, **1782–1784**  
   unconscious fantasies and, 1817  
   See also Klein-anna Freud conflict  
   “Child Is Being Beaten, A” (Freud)  
   amnesia and, 65  
   on castration complex, 253  
   on cruelty, 354  
   on fantasy, 551, 553  
   on inferiority feelings, 831  
   on masochism, 1021  
   on mastery, 1024  
   on perversion, 1258  
   on representation, 782  
   on sadomasochism, 1527  
   on skin, 1612  
   on subject, 1675  
 Childbearing, wish for. See Wish for a baby  
 Childhood, **280–282**  
   abandonment in, 1–3  
   adolescence and, 28–29  
   culture and, 282  
   death and, 370  
   *Fort-da* game and, 280, 283, 599–600  
   Hoffer on, 752, 753  
   hospitalization during, 120  
   individual and, 810  
   nakedness dreams and, 1103  
   phobias in, 1273–1275  
   primitive and, 1319  
   repetition and, 1473–1474  
   *Childhood and After* (Isaacs), 874  
   *Childhood and Society* (Erikson), **282**, 477, 511  
   *Childhood in Contemporary Cultures* (Mead and Wolfenstein), 1870



## INDEX

Volume 1, pp. 1–662; Volume 2, pp. 663–1344; Volume 3, pp. 1345–1892

- Childhood of the Artist, The* (Greenacre), 702  
 Childhood sexuality. *See* Infantile sexuality  
 Children, treatment of  
   analytic psychodrama, 78–79  
   Argentinian psychoanalysis and, 117  
   Baginsky on, 146  
   Centre Alfred-Binet, 263, 263–264, 410, 911, 955  
   Centre psychopédagogique Claude-Bernard and, 265  
   Controversial Discussions and, 343–344  
   Detski Dom, 402–403, 1515, 1518, 1544  
   École expérimentale de Bonneuil and, 456–457  
   group psychotherapy, 5  
   Hellman Noach and, 732–733  
   infant observation and, 818–819  
   Institut Claparède, 841–842  
   Mannoni-Van der Spoel and, 1010  
   psychodrama, 5  
   *See also* Hampstead Clinic  
*Children in Conflict, Twelve Years of Psychoanalytic Practice* (Rambert), 1442  
*Children in Need* (Schmideberg-Klein), 1543  
*Children of Oedipus* (Lapuz), 1268  
*Children of the Dream, The* (Bettelheim), 173  
 Children's Hospital of Michigan, 1658  
 Children's play, **282–284**  
   active imagination and, 14  
   activity/passivity and, 17  
   child analysis and, 279, 281  
   creativity and, 351  
   humor and, 762  
   transitional phenomena and, 1797  
 Chilean psychoanalysis, **284–285**, 1033  
 Chinese psychoanalysis, **285–287**  
 Chiozza, Luis, 118  
 Cho Doo-Young, 921  
 Chodorow, Nancy, 577  
 Choice of neurosis, **287–289**, 345, 435  
 Choisy, Maryse, 211, **289–290**, 609, 1252  
   *See also* *Psyché, revue internationale de psychanalyse et des sciences de l'homme*  
*Chora*, 578  
 Christianity  
   anti-Semitism and, 1437  
   parricide and, 1078, 1092  
   perversion and, 1257  
   Pfister on, 1260  
   rituals and, 1504  
   *See also* Catholicism; Religion  
*Christianity and Fear* (Pfister), 1260  
*Christians and Jews: A Psychoanalytical Study* (Loewenstein), **291**, 988, 1438  
 Christoffel, Hans, 1550, 1703  
*Christus*, 266  
 Chrobak, Rudolf, 239  
 Chronic disorganization, 1409  
 Chrzanowski, Gerard, 852  
 Ciaccia, Antonio di, 880  
 Cid, Sobral, 1296  
 Cifali, Mario, 195, 1701  
 Cifali, Mireille, 195, 1701  
 Cinema, **292–296**  
   Allendy-Nel-Dumouchel on, 45  
   allergic object relationship in, 47  
   definition of psychoanalysis and, 1365  
   documentary films, 1603  
   on Freud, 293, 642, 644–645  
   German psychoanalysis and, 674  
   Lainé and, 937  
   Rank on, 429  
   *Secrets of a Soul, The*, 293, 294, 295, 1365, 1523, 1562–1563  
   *See also* Creativity  
 Círculo brasileiro de psicanálise, 217  
 Cividini-Stranic, Eugenie, 1884  
 Civilization, **298–300**  
   Darwinism and, 367  
   disillusionment and, 1750–1751  
   religion and, 1467  
*Civilization and Its Discontents* (Freud), **296–298**  
   on altruism, 53–54  
   on anal eroticism, 515  
   on anthropology, 93  
   on castration complex, 255  
   collective psychology and, 311  
   on communism, 1519  
   on conflict, 326  
   on death instinct, 372, 983–984  
   definition of psychoanalysis and, 1364  
   on disillusionment, 1750  
   on ego, 466  
   on ego-instincts, 483  
   on ethics, 525  
   on fire, 1367  
   on guilt, 716  
   on incest, 804  
   on individual, 810  
   jouissance and, 894–895  
   on memories, 1040–1041  
   on myth of origins, 1321  
   on narcissism of minor differences, 1109  
   on oceanic feeling, 425, 660, 895, 1181–1182, 1511  
   on organic repression, 1207, 1208  
   on parricide, 1238–1239  
   Pichon and, 1283  
   on politics, 1293  
   publication of, 640–641  
   on racism/anti-Semitism, 1438  
   on repetition compulsion, 1475  
   on repression, 1479  
   on sense of smell, 1616  
   on suffering, 1683  
   on superego, 1690  
   on taboo, 1723  
   on transgression, 1792  
   on urethral eroticism, 517  
   “Why War?” and, 1856  
   “Civilized Sexual Morality and Modern Nervous Illness” (Freud), 298, 299, 311, 797, 804, 1023, 1632, 1750–1751, 1855  
 Cixous, Hélène, 328, 577  
 “Claims of Psycho-Analysis to Scientific Interest, The” (Freud), 93, **300–301**, 462, 1192, 1293, 1632  
 Clair, Jean, 1842  
 Claparède, Édouard, **301–302**  
   *Archives de psychologie, Les* and, 115, 116, 301–302, 592  
   Binet and, 89  
   *Disque vert, Le* and, 423, 424  
   Favez and, 560  
   on mentalization, 1046  
   Odier and, 1182  
   Piaget and, 1282  
   Sechehaye and, 1556  
   Swiss psychoanalysis and, 1620, 1700  
 Clark, Ronald W., 642  
 Clark University, 207, **302–303**, 1424  
 Clark-Williams, Margaret, **303–304**  
   Berge and, 161  
   Bonaparte and, 200  
   Favez-Boutonier and, 560  
   French psychoanalysis and, 609  
   Mauco and, 1034  
   Société psychanalytique de Paris and, 1625  
   Torok and, 1764  
 Clarté movement, 1697  
 Classical school of analytical psychology, 80  
*Classification française des troubles mentaux de l'enfant et de l'adolescent* (Misès), 1276  
 “Classified Index of the Major Concepts” (Miller), 460  
 Claude, Henri Charles Jules, **304–306**

Volume 1, pp. 1–662; Volume 2, pp. 663–1344; Volume 3, pp. 1345–1892

- Allendy and, 46, 305, 1345–1346  
 Borel and, 205  
 Cénac and, 261  
 Congrès des psychanalystes de langue française des pays romans and, 329  
 Dalbiez and, 363  
 Delay and, 305, 382  
*Disque vert, Le* and, 424  
 Ey and, 539  
 French psychoanalysis and, 607  
 Lacan and, 929  
 Laforgue and, 933, 1345–1346  
 Lagache and, 935  
 Nacht and, 305, 1101  
 Nodet and, 1152  
*Revue française de psychanalyse* and, 305, 1497–1498  
 Sainte-anne Hospital and, 1528  
 Société psychanalytique de Paris and, 1624  
 Sokolnicka-Kutner and, 1634  
 Claus, Carl, 1838  
 Claustrophobia, **306–307**  
 Clavreul, Jean  
   on alcoholism, 41, 42  
 Centre d'études et de recherches freudiennes and, 1083  
*Confrontation* and, 327  
 École freudienne de Paris and, 457–458  
 French psychoanalytic establishment split (1964) and, 1619  
*Inconscient, L'* and, 129, 528, 611, 806, 807, 1835  
   on perversion, 1259  
 Clément, Catherine, 327  
 Clément, Louis, 1154, 1155  
 Clementis, Lina Generali, 879  
 Clérambault, Georges de  
   on automatism, 143  
   on erotomania, 522  
 Lacan and, 929  
 Nodet and, 1152  
   on passion, 1243  
   on perversion, 1259  
 Clinging instinct, **307**  
   Hermann on, 307, 737, 1438  
   tenderness and, 1736  
 “Clinical Approach to the Psychoanalytic Theory of the Life and Death Instincts, A” (Rosenfeld), 1515  
 “Clinical Aspects of Psychoanalysis” (Porto-Carrero), 1295  
*Clinical Journal* (Ferenczi), 328, 581, 1090, 1315, 1465, 1781  
 Clinical practice. *See* Psychoanalytic treatment  
*Clinical Studies in Psychoanalysis* (Lorand), 991  
 “Clinique psychanalytique, La. La relation d’objet” (Bouvét), 211  
*Clinique psychanalytique* (Laforgue), 544  
 Clitoris  
   amphimixia and, 66  
   castration complex and, 251, 253  
   female sexuality and, 570, 573, 1753  
   perversion and, 1258  
 Clouzet, Maxime, 1350  
 “Cluster A and Cluster B” (Balint), 160  
 Cobb, Stanley, 43, 208, 405  
*Cobweb, The* (film), 293  
 Cocaine, **307–308**  
 Cocteau, Jean, 45  
*Code Name “Mary”* (Gardiner), 664  
 Codet, Henri, 329, 532, 1624  
 Codet, Odette. *See* Laurent-Lucas-Championnière-Maugé, Odette  
*Cogito*, 44  
 Cognitivism, 65, **308–309**, 380, 1064  
 Cohen, Robert, 1517  
 Cohen, Yecheskiel, 877–878  
 Cold psychoses, 911  
 Cold War, 609, 1519, 1557, 1558, 1602  
*Collected Papers: Through Paediatrics to Psychoanalysis* (Winnicott), 1107, 1796  
*Collected Papers on Schizophrenia and Related Subjects* (Searles), **309–311**  
 Collective hypnosis, 44  
 Collective psychology, 311, **311–312**, 712, 1724  
 Collective unconscious, **312–314**  
   Allendy on, 46  
   amplification and, 67  
   animus/anima and, 87  
   archetypes and, 115, 313  
   numinous and, 1164–1165  
 Collège des Psychanalystes, **314**, 612, 1835  
 Colloque de Bonneval. *See* Colloque sur l’inconscient  
 Colloque sur l’inconscient, **314–315**, 610, 969, 1046  
 Coloma, Jaime, 285  
 Colombian psychoanalysis, **315–316**  
 Colonization  
   Fanon on, 549–550, 1014  
   Indian psychoanalysis and, 808  
   North African psychoanalysis and, 1154, 1155  
   racism and, 1437  
 Colorni, Renata, 1199  
 Columbia University Clinic for Psychoanalytic Training and Research, 906  
 Combined parent figure, **316**, 1188, 1262, 1311  
*Coming of Age in Samoa* (Mead), 1035  
 Commensal relations, 1464  
 “Common Neurotic State, The” (Freud), 20  
 Common sense, 419  
*Communicating Vessels* (Breton), 37, 1695  
 Communication theory, 980  
 Communism  
   Allendy and Allendy-nel-Dumouchel on, 45  
   Althusser and, 53  
   Chinese psychoanalysis and, 286  
   Detski Dom and, 402–403, 1518  
   French psychoanalysis and, 609  
   Hungarian psychoanalysis and, 764, 766  
   Lacan and, 37, 611  
   Lebovici and, 954  
   Polish psychoanalysis and, 1292  
   Poltzer and, 1294  
   Róheim and, 1510  
   Rolland and, 1511  
   Romanian psychoanalysis and, 1511  
   Russian/Soviet psychoanalysis and, 1518–1519  
   surrealism and, 1695  
   Zweig, Arnold and, 1889  
 Compensation, **317**  
   dream interpretation and, 865  
   extroversion/introversion and, 538  
   unconscious and, 538  
 Compensatory structures, **317–318**  
 Complementary series, **318**  
 Complementary zone-object, 189, 505  
 Complexes, **318–321**  
   imago and, 800  
   Jung on, 319, 320–321, 557, 800, 902, 1872  
   structural theories and, 1666  
   *See also* Castration complex; Oedipus complex  
*Complexes familiaux dans la formation de l’individu, Les* (Lacan), 801, 1851  
 Component instincts, 518, 519, 1612, 1752  
 Compromise formations, **321–322**  
   Arlow on, 119–120  
   conflict and, 325  
   contradiction and, 341  
   displacement and, 421  
   fantasy and, 554  
   flight into illness and, 590

## INDEX

Volume 1, pp. 1–662; Volume 2, pp. 663–1344; Volume 3, pp. 1345–1892

- modern conflict theory on, 1066  
 parapraxes and, 1235  
 reaction-formations and, 1449  
 rituals and, 1504  
 substitute formations and, 1681  
**Compulsion, 322–323**  
 “A. Z.” on, 1  
 basic fault and, 151  
 character and, 271  
 dipsomania and, 412  
 obsessional neurosis and, 323, 1180  
 obsessions and, 322, 1178  
 “Compulsive activities and religious exercise” (Freud), 660  
 Comte, Auguste, 159, 1631  
 Concentration camps  
 Bettelheim on, 172, 503  
 Frankl on, 615  
 Freud family and, 634, 635, 641, 899  
 See also Holocaust; Nazi Germany  
*Concepcao Freudiana das Psiconeuroses* (Cesar de Castro), 214  
*Concept of Repression* (Bose), 206  
*Conceptia Psihanalitica* (Popescu-Sibiu), 1511  
*Conceptions of Modern Psychiatry* (Sullivan), 1688  
 Concepts, **323–324**  
 Condemning judgments, **900–901**  
 Condensation, **324–325**  
 day’s residues and, 367  
 dreams and, 437, 438, 441, 442, 1047  
 forgetting and, 597  
 formations of the unconscious and, 598  
 letter and, 961–962  
 metaphor and, 1047  
 primary/secondary processes and, 1318  
 representability and, 1477  
 reversal into the opposite and, 1494  
 secondary revision and, 1559  
 signifier/signified and, 1606  
 slips of the tongue and, 1616  
 subject’s desire and, 1677  
*Conditions of Nervous Anxiety and Their Treatment* (Stekel), 1657  
 Conflict, **325–327**  
 analytic psychodrama and, 78  
 modern conflict theory on, 1065–1066  
 negation and, 1122  
 shadow and, 1596  
*Confrontation*, 240, 314, **327–328**, 611, 612, 1835  
 Confrontation anxiety, 1648  
*Confrontations with Myself* (Deutsch-Rosenbach), 405  
 Confucianism, 285  
 “Confusion of Tongues between Adults and the Child” (Ferenczi), **328–329**, 440, 581, 870, 1465, 1643  
 Congrès des psychanalystes de langue française des pays romans, **329–331**, 608, 609, 1252, 1498, 1499, 1536, 1625  
 Congrès international de l’hypnotisme expérimental et scientifique, Premier (1889), **331–332**  
 Congrès mondial de psychiatrie (1950), 532, 539  
 Congress of Psychiatrists, 329  
*Connaissance de l’enfant par la psychanalyse, La* (Lebovici and Soulé), 955  
*Connaissance de l’inconscient*, 611  
 Connell, E. H., 545  
 Conscious processes, **332–333**  
 Consciousness, **333–334**  
 alpha function and, 50  
 attention and, 127  
 belief and, 158  
 conflict and, 326  
 conscious processes and, 332–333  
 contact-barrier and, 339–340  
 ego and, 464, 469  
 forgetting and, 596, 597  
 mnemonic traces and, 334, 1063–1064, 1065  
 neurophysiology and, 213  
 philosophy and, 1270  
 self and, 1567  
 self-consciousness, 50, 1569–1570  
 Consensual validation, 419  
 “Considérations sur les anomalies du comportement sexuel chez l’animal” (Favreau), 562  
 Consistency, 417  
 Constancy principle, **1322–1323**, 1325  
 anxiety and, 102  
 excitation and, 534  
 Fechner on, 565  
 Nirvana principle and, 1151, 1323  
 Constitution, **334–335**  
 concept and, 324  
 doubt and, 435–436  
 fixation and, 588  
 Lacan on, 37  
 mythomania and, 1098  
*Construction de l’espace analytique, La* (Videman), **335–336**, 848, 1043, 1835  
 Constructions, **336–337**  
 amnesia and, 65  
 anticipatory ideas and, 96  
 Freud on, 336–338  
 interpretation and, 862  
 Videman on, 335  
 “Constructions in Analysis” (Freud), **337–338**  
 on amnesia, 65, 977  
 on anticipatory ideas, 96  
 on historical truth, 749, 750  
 on infantile amnesia, 820  
 on primal scene, 1310  
 on transference relationship, 1787  
 on work, 1876  
 Consumerism, 92  
 Contact, **338–339**  
 body image and, 197  
 mastery and, 1025  
 rituals and, 1504  
 taboo and, 1724  
 tenderness and, 1736  
 Contact-barrier, 50, **339–340**, 340  
 Container-contained, **340–341**  
 alpha function and, 51–52  
 arrogance and, 121  
 Bion on, 184, 340, 850  
 frame of psychoanalytic treatment and, 606  
 internal objects and, 850  
 object and, 1170  
 pain and, 1220  
 thought-thinking apparatus and, 1750  
 Conté, Claude, École freudienne de Paris and, 458  
 “Contra-Indications to the ‘Active’ Psychoanalytical Technique” (Ferenczi), 16  
 Contradiction, **341–342**, 345  
 Contri, Giacomo, 880, 1199  
 “Contribution à l’étude des phobies” (Mallet), 1273, 1275  
 “Contribution to the Analysis of the Negative Therapeutic Reaction, A” (Riviere-Hodgson Verrall), 1507  
 “Contribution to the Pathopsychology of Phenomena Associated with Falling Asleep, A” (Isakower), 874  
 “Contribution to the Understanding of Schizophrenic Speech, A” (Katan), 191  
 “Contribution to the Understanding of the Symbolic Meaning of the Circle, A” (Alvarez de Toledo), 55  
 “Contributions to the Psychology of Love” (Freud), 251–252, **342–343**, 1594, 1725  
 Control analysis, 602–604, **1692–1693**  
 Control analysis. See Supervised analysis

Volume 1, pp. 1–662; Volume 2, pp. 663–1344; Volume 3, pp. 1345–1892

- Control-Mastery Theory, **1532–1533**
- Controversial Discussions, 228, 229, **343–344**, 619, 697, 915, 1644
- Bowlby and, 212
- Brierley and, 226
- definition of psychoanalysis and, 1363
- Envy and Gratitude* and, 509
- Friedländer-Fränk and, 646
- Glover, Edward and, 684
- Heimann and, 730
- Isaacs-Sutherland and, 343, 344, 697, 873–874
- Jones and, 893
- Low and, 997
- Payne and, 343, 344, 697, 1245
- Schmideberg-Klein and, 1543
- Second World War and, 1558
- Winnicott and, 1861
- See also Klein-anna Freud conflict
- Convenience dreams, **344–345**, 1864
- Convention psychanalytique, 612
- Convergence, 1084
- Conversion, **345–346**, 772, 773
- allergies and, 47, 48
- biological bedrock and, 182
- “Cäcilie M.” case and, 240
- as defense neurosis, 19
- discharge and, 418
- excitation and, 534
- hysterical paralysis and, 774
- innervation and, 836
- neurotic defenses and, 1142
- psychosomatic limit and, 1410
- psychosomatics and, 345, 1409
- somatic compliance and, 1635
- stammering and, 1653, 1654
- symptoms and, 1715
- Conversion hysteria. See Conversion
- Cooper, Arnold, 888, 1533
- Cooper, David, 699
- Coordinating Committee for Latin American Psychoanalytic Organizations (COPAL), 150, 216, 565, 1447
- See also Federación psicoanalítica de América latina
- COPAL. See Coordinating Committee for Latin American Psychoanalytic Organizations
- Coppens, Yves, 1739
- Coprophagy, 72
- Coprophilia, **346**, 1616, 1756
- Coq-Héron, Le*, **347**
- Coriat, Isidor, 207
- Corman, Louis, 1395
- Corominas, Julio, 1637
- Corona, Carlos, 1051
- Corps et le politique, Le*, 241
- Corrao, Francesco, **347–348**, 880, 881, 1758
- Cortazar, Julio, 241
- Côrtes de Barros, João, 215
- Corti, Adda, 879
- Costoriadis, Cornélius, 807
- Cotet, Pierre, 124
- Couch in New York, A* (film), 294
- Coué, Émile, 144, 1432
- Counter-cathexes. See Anticathexes
- Counter-identification, **348**
- Counter-Oedipus, **348–349**, 1465
- Counter-transference, **349–351**, 1368
- analysand and, 75
- analytical psychology on, **1779–1780**
- Balint groups on, 147
- boundary violations and, 209
- case histories and, 250
- change and, 268
- child analysis and, 350, 1733, 1784
- complexes and, 321
- constructions and, 335
- container-contained and, 340
- counter-identification and, 348
- dead mother complex and, 368
- direct analysis and, 414
- “Dora” case and, 604
- elasticity and, 494
- empathy and, 502
- Hirschfeld, Elfriede and, 747
- indications/contraindications for psychoanalysis and, 809
- infantile neurosis and, 820
- Jung and, 639, 747
- mother and, 577
- mutual analysis and, 1090
- nonverbal communication and, 1153–1154
- patient physical position and, 542
- psychoanalytic semiology and, 1380
- Racker on, 1440, 1778
- Searles on, 310
- Servadio on, 1586
- silence and, 1610–1611
- termination of treatment and, 77
- Counterfeiters, The* (Gide), 1634
- Counterphobic phenomena, **349**
- “Counting with Psychoanalysis” (Leclaire), 1668
- Cournut, Jean, 1499
- on intervention, 863
- on phantom, 1266
- on secrets, 1560
- Société psychanalytique de Paris and, 1628, 1630, 1631
- on transference hatred, 1782
- Cournut, Monique, 1630
- Cournut-Janin, Monique, 264, 578
- Cours de philosophie positive* (Comte), 1631
- Course of General Linguistics* (Saussure), 1604
- Course of Life, The* (Fliess), 589
- “Couvade und die Psychogenese der Vergeltungsfurcht, Die” (Reik), 1237
- Couvrette, Jean-Jacques, 864
- Couvreur, Catherine, 1782
- Covello, Lucio, 528, 806
- Cox, John, 1297
- CPS (Canadian Psychoanalytic Society), 241–242, 243–244, 1620–1623
- Cramer, Bertrand
- child analysis and, 1784
- on developmental processes, 1330
- on encopresis, 504
- on infantile psychosis, 825
- Psychoanalytic Study of the Child, The* and, 1382
- Swiss psychoanalysis and, 1701
- “Creative Writers and Day-dreaming” (Freud), **351–352**
- Abraham and, 443
- applied psychoanalysis and, 107
- on daydreams, 555, 1494
- on fantasy, 551
- on reader, 985
- Creativity, **352–353**
- action-thought and, 13, 14
- adolescence and, 27
- Allendy-Nel-Dumouchel on, 45
- Anzieu on, 643
- applied psychoanalysis and, 107–108
- Blackett-Milner on, 190
- Borel on, 204
- Brazilian psychoanalysis and, 216–217
- complexes and, 321
- deprivation and, 397
- Freud on, 351
- Greenacre on, 702
- heroic self and, 739–741
- humor and, 352, 890
- infantile omnipotence and, 822
- intellectualization and, 844
- Lacan on, 37

## INDEX

Volume 1, pp. 1–662; Volume 2, pp. 663–1344; Volume 3, pp. 1345–1892

- narcissism and, 14  
 nonintegration and, 843–844  
 popularity of psychoanalysis and, 62  
 reparation and, 1472  
 Rycroft on, 1521  
 sexuality and, 1594  
 sublimation and, 1679  
 sudden involuntary ideas and, 1683  
 surrealism and, 1695–1696  
 symbolization and, 1714  
 transference of, 1787–1788  
 transitional phenomena and, 1794, 1795  
*See also* Cinema; Literature; Visual arts  
 Cremerius, Johannes, 678  
 Crémieux, Rosine, 410  
 Crevel, René, 37, 46, 1695  
 Crews, Frederic C., 987  
 Crichton-Miller, Hugh, 699, 1457, 1727  
*Cries and Whispers* (film), 294  
 “Crime de l’introjection, Le” (Torok and Abraham), 870  
*Crime of Punishment, The* (Menninger), 1045  
*Criminal Sociology* (Ferri), 353  
 “Criminals from a Sense of Guilt” (Freud), 353  
*Criminologia* (Garofalo), 353  
 Criminology, 353–354  
 Alexander, Franz Gabriel on, 43  
 Cénac on, 261  
 Friedländer-Fränk on, 646  
 Glover, Edward on, 684  
 Lacan on, 261  
 Menninger on, 1045  
 passage to the act, 10, 18–19, 1390  
 Schiff on, 1537  
 Crisanto, Carlos, 1254  
*Crise d’originalité juvénile, La* (Debesse), 28  
*Critica*, 116  
*Critical Dictionary of Psychoanalysis, A* (Rycroft), 1521  
 “Critical Notes on the Theory of the Preenital Organization of the Libido” (Balint), 149  
 Critical-paranoia, 1695  
 Critical theory, 30–32  
*Critique de la raison dialectique* (Sartre), 1352  
*Critique des fondements de la psychologie* (Politzer), 1294  
 Croatian psychoanalysis, 1884  
 Croce, Benedetto, 879  
 Cross-cap, 1763  
*Crowd, The* (Le Bon), 953  
 Crowds, 1632  
 Cruelty, 354–356  
 erotogenic zones and, 519  
 mastery and, 354, 355, 917, 1025  
 moral masochism and, 1071  
 superego and, 1691  
 urethral eroticism and, 517  
 Crypt, 7  
 Cryptomnesia, 356–357, 591–592  
 “Cryptomnesia” (Jung), 356  
 Csáth, Géza, 765  
 Csillag, Sidonie, 1391  
*See also* “Psychogenesis of a Case of Homosexuality in a Woman, The”  
 Cullen, William, 1414  
 Cullère, A., 1136  
 Cultural transmission, 357–358  
 Culture  
 amplification and, 67  
 analytical psychology on, 79  
 animus/anima and, 87  
 anthropology and, 92–93  
 Bettelheim on, 173  
 childhood and, 282  
 civilization and, 298  
 in *Civilization and Its Discontents*, 296–297  
 definition of psychoanalysis and, 1364, 1365  
 Devereux on, 154  
 dream symbolism and, 441  
 ego syntony and, 489–490  
 ethics and, 525  
 ethnopsychanalysis and, 526–527  
 family and, 547  
 feminist views of psychoanalysis and, 577  
 Filipino psychoanalysis and, 1268  
 Fornari on, 598  
 Freud on, 296–297, 640, 641  
 heroic self and, 739–740  
 Horney-Danielson on, 58, 59, 759, 1824  
 hypnosis and, 769  
 Indian psychoanalysis and, 807, 808  
 individual and, 810  
 inferiority feelings and, 832  
 Kardiner on, 906  
 Korean psychoanalysis and, 921  
 Martinican psychoanalysis and, 1014  
 Marxism on, 1018  
 Mead on, 1035  
 myth of origins and, 1092  
 mythology and, 1095–1096  
 Oedipus complex and, 1186  
 reaction-formations and, 1449  
 Róheim on, 1510  
 transcultural perspectives, 1774–1775, 1870  
*Weltanschauung* and, 1854–1855  
 Cumulative trauma, 913  
 Cuny, Alain, 934  
 Cupello, Nicolás, 1832  
 Cure, 358–360, 1385, 1777, 1787  
 “Cure-type, La” (Bouvét), 210  
 Curiosity, 121  
*See also* Infantile sexual curiosity  
 Custodio de Faria, Abbé José, 85, 1295  
 Cutting, 1572  
 Cybernetic theory, 1720  
 Cybernetics, 143  
*Cyrano de Bergerac*, 54  
 Cyssau, Catherine, 563  
 Czech psychoanalysis, 78, 360, 360–361, 432–433, 1212  
 Czech Study Group, 360, 361  
 Czinner, Alice, 737
- D**  
 Da Silva, Guy, 245  
 Dadaism, 45, 708  
 Dahl, Hartvig, 1517  
 Dahleim, Luis, 566  
 Dahmer, Helmut, 1351  
 Dai, Bingham, 286  
 Daimonion, 153  
 Dalbiez, Roland, 363–364  
 Claude and, 305  
 Desoille and, 400  
 on epistemology, 1371  
 Ey and, 363, 539  
 French psychoanalysis and, 608  
 Pichon and, 363, 1283  
 Dalí, Salvador, 37, 293, 1695  
 Dallal, Eduardo, 1052  
 Damourette, Jacques, 982, 1283  
 Dane, Paul Greig, 130, 131, 132  
 Danger, 364  
 animistic thought and, 85  
 annihilation anxieties and, 90  
 anxiety and, 102, 364  
 ego functions and, 479  
 fear and, 563  
 war and, 598  
 Daniels, George, 906  
 Danish psychoanalysis, 390–391  
 Danish Psychoanalytic Society, 391

Volume 1, pp. 1–662; Volume 2, pp. 663–1344; Volume 3, pp. 1345–1892

- Dansereau, Michel, 245  
 Dante Alighieri, 986  
 Dare, Christopher, 1533  
 Dark continent metaphor, **365–366**, 1175  
*Dark Wood to White Rose* (Luke), 986  
 Darwinism, **366–367**  
   Breuer and, 224  
   criminology and, 353  
   German romanticism and, 673  
   Hall and, 721  
   heredity of acquired characters and, 736  
   Jelliffe and, 889  
   mnemic traces and, 1064  
   ontogenesis and, 1196–1197  
   phylogenesis and, 366–367, 1277  
   prehistory and, 1303  
   primitive and, 1319  
   primitive horde and, 1320, 1768  
   psychosomatics and, 1408  
*Daseinanalyse*, 181, 231, 615, 1267, 1535  
 Daudet, Alphonse, 1098  
 Daumézon, Georges, 807, 1766  
 Daunou, Pierre, 795  
 Davanzo, Hernán, 284, 285  
 David, Christian  
   Congrès des psychanalystes de langue française des pays romans and, 331  
   on genital love, 671  
   *Inconscient, L'* and, 807  
   Marty and, 1016  
   on masculinity/femininity, 1020  
   on psychosomatics, 610, 1407, 1409  
   *Revue française de psychanalyse* and, 1499  
   Société psychanalytique de Paris and, 1628  
   on state of being in love, 1656  
   on suffering, 1684  
   Viderman and, 1835  
 David, Michel, 881  
 David, Myriam, 129  
 Davidson, Andrew, 130  
 Davidson, Shamaï, 877  
 Dayan, Maurice, 848, 1353  
 Daydreams  
   directed, 414–415  
   illusion and, 796  
   projection and, 1336  
   reverie and, 554–555, 1493–1494  
   secondary revision and, 1559  
   unconscious fantasies and, 1817  
   wish-fulfillment and, 1865  
   *See also* Reverie  
 Daymas, Simone, 1005  
 Day's residues, **367–368**, 437, 438, 442  
   “Irma's injection” dream and, 872  
   latent/manifest dream elements and, 947, 948, 1007  
   *See also* Mnemic traces  
 De Beauvoir, Simone, 576, 644  
 De Boor, Clemens, 1602  
*De la psychanalyse à la médecine psychosomatique* (Held), 731  
*De la psychose paranoïaque dans ses rapports avec la personnalité* (Lacan), 36, 38, 104, 459, 532  
 “De la topic réalitaire: Notations sur une métapsychologie du secret” (Abraham and Torok), 1560  
*De l'angoisse à l'extase* (Janet), 250, 886  
*De l'argent en psychanalyse et au-delà* (Viderman), 1836  
*De l'interprétation, essai sur Freud* (Ricoeur), 459, 611  
 De Ruggiero, Guido, 1508  
 De Sade, Marquis, 905  
 De Sanctis, Sancte, 824, 827, 1832  
 De Zubiría, R., 315  
 “Dead Mother, The” (Green), 1780  
 Dead mother complex, **368–369**  
*Deadly Innocents, The: Portraits of Children Who Kill* (Gardiner), 664  
 Death, **369–371**, 1751  
   amphimixia and, 66–67  
   animistic thought and, 86  
   breastfeeding and, 220  
   certainty and, 266  
   dipsomania and, 412–413  
   dreams and, 370, 1810–1811  
   estrangement and, 524  
   *Fort-da* game and, 600  
   orgasm and, 1209  
 Death drive. *See* Death instinct  
 Death instinct (Thanatos), **371–373**  
   Abraham, Nicolas on, 7  
   activity/passivity and, 17  
   alienation and, 44  
   antinarcissism and, 97, 1114  
   anxiety and, 100  
   attacks on linking and, 983–984  
   autistic capsule and, 138  
   *Beyond the Pleasure Principle* on, 174  
   binding/unbinding and, 179  
   biological bedrock and, 182  
   castration complex and, 254, 255  
   character and, 271  
   conflict and, 326  
   constancy principle and, 1323  
   cruelty and, 355  
   culture and, 297  
   cure and, 359  
   defenses and, 375  
   desexualization and, 399  
   destrudo and, 400  
   dipsomania and, 413  
   discharge and, 417  
   disintegration anxieties and, 418  
   disorganization and, 421  
   drives and, 446, 447  
   dualism and, 449  
   ego and, 372, 464  
   ego-instincts and, 483  
   envy and, 508, 509  
   erotogenic masochism and, 517  
   essential depression and, 523  
   ethics and, 526  
   excitation and, 534  
   externalization-internalization and, 537  
   Fechner and, 565  
   free energy/bound energy and, 617  
   fusion/defusion and, 658, 659  
   guilt and, 716  
   helplessness and, 734  
   id and, 777  
   identification and, 640, 788  
   Klein on, 175, 372, 373, 915, 1139  
   Lacan on, 175, 372, 373  
   libido and, 968  
   life instinct and, 371, 372, 511–512  
   masochism and, 371, 372, 512, 1020–1021, 1022  
   mastery and, 1025  
   moral masochism and, 372, 1072  
   narcissism and, 1107  
   negative therapeutic reaction and, 1126  
   negative transference and, 1127  
   neuroses and, 1139  
   Nirvana principle and, 371, 1151, 1152  
   operational thinking and, 1199  
   paranoid-schizoid position and, 1233  
   parricide and, 1239  
   phobias and, 1274, 1276  
   primary masochism and, 1125  
   projective identification and, 1338, 1339  
   protective shield and, 1341  
   racism/anti-Semitism and, 1439  
   repetition compulsion and, 371, 1474–1475  
   Rosenfeld, Herbert on, 1515

## INDEX

Volume 1, pp. 1–662; Volume 2, pp. 663–1344; Volume 3, pp. 1345–1892

- sadism and, 371, 1526  
 sadomasochism and, 1527  
 Schilder on, 1538  
 secrets and, 1560  
 sexuality and, 1593  
 Spielrein on, 1639  
 splitting and, 1646  
 splitting of the object and, 1642  
 sublimation and, 1679  
 superego and, 372, 1691  
 trauma and, 1801  
 Weiss on, 372, 1854  
 “Why War?” on, 1856  
 Debesse, Maurice, 28  
 Debray-Ritzen, Pierre, 612  
 Decartes, Rene, 1675  
 Decathexis, **373–374**  
 dismantling and, 419  
 paranoia and, 1230  
 pleasure in thinking and, 1289  
 psychotic potential and, 1418  
 Decherf, Gérard, 1226  
 Decobert, Simone, 138, 1247, 1628  
 “Decomposition of the Psychic Personality”  
 (Freud), 1160, 1479  
 Deconditioning, 19  
 Dedekind, Richard, 1816  
*Deep Analysis, the Clinical Study of an  
 Individual Case* (Berg), 82  
*Defeat of Baudelaire, The* (LaFargue), 974  
 Defecation  
 anaclysis and, 68  
 anal eroticism and, 514–515  
 anal-sadistic stage and, 73–74  
 anality and, 72  
 coprophilia, 346  
 encopresis, 504  
 gifts and, 682  
 mastery and, 1024  
 Defenestration phobia, 1272  
 Defense mechanisms, **376–377**  
 alteration of the ego, 469  
 altruism and, 54  
 anxiety and, 100  
 boredom as, 204  
 Bornstein on, 205  
 character and, 269–270  
 choice of neurosis and, 288  
 compensatory structures and, 317–318  
 depression and, 394  
 ego and, 466, 477, 479  
 estrangement and, 524  
 idealization and, 783  
 identification with the aggressor and, 792  
 isolation, 875–876  
 megalomania and, 1036  
 negation as, 1121  
 paranoid-schizoid position and, 375  
 process and, 1328  
 racism and, 1437  
 suppression and, 1693–1694  
 symptoms and, 1715  
 turning around and, 1808  
*See also* Defenses  
 Defense neuroses, **19–20**, 325, 326, 1135  
 Defenses, **374–376**  
 alcoholism and, 41  
 fantasy and, 552, 553, 554  
 Horney-Danielson on, 1140–1141  
 identification with the aggressor, 792–793  
 intellectualization, 844  
 neurotic, 1141–1142  
 psychic structure and, 1359  
 psychotic, 1413–1414  
 psychotic panic and, 1416  
 sexual drive and, 445  
*See also* Defense mechanisms  
 Deferred action, **377–381**  
 adolescence and, 26  
 anaclysis and, 68  
 archaic and, 113  
 child analysis and, 1733  
 displacement and, 422  
 fatherhood and, 558  
 Graph of Desire and, 693  
 incompleteness and, 805  
 mnemonic traces and, 379, 380, 1064  
 primary identification and, 1313  
 repetition and, 1472  
 repression and, 1479, 1483  
 Rosolato on, 613  
 seduction scenes and, 1565  
 seduction theory and, 670, 1592  
 stages and, 1652  
 trauma and, 1801, 1802  
 war neuroses and, 1848, 1849  
 Deflation, 1596  
 Defusion. *See* Fusion/defusion  
 Degeneracy, 37, 1524  
 Deglado, Honorio, 116  
 Degoumois, Claire, 1701  
 Déjà raconté, 382  
 Déjà vécu, 382, 524  
 Déjà vu, 265, **381–382**, 524, 796  
 Déjerine, Jules, 106, 695, 1345, 1414, 1529  
*Del psicoanálisis a la Psicología social*  
 (Pichon-Rivière), 1285  
 Delarai-Chabaux, Catherine, 1572  
 Delay, Jean, **382–383**  
 Claude and, 305, 382  
 Enriquez-Joly and, 506  
 on narco-analysis, 1117  
 Parcheminey and, 383, 1236  
 Pasche and, 1241  
*Psyché* and, 1350  
 Sainte-anne Hospital and, 1528  
 Delboeuf, Joseph Rémi Léopold, **383–384**  
 on autosuggestion, 144  
 Congrès international de l’hypnotisme  
 expérimental et scientifique, 331, 332  
*Disque vert, Le* and, 424  
 on hypnosis, 769, 1685  
 Deleuze, Gilles, 97–99, 612  
 philosophy and, 1271  
 on politics, 1293  
 on Spinoza, 1640  
 on structuralism, 1668–1669  
 Delgado, Gustavo, 1254  
 Delgado, Honorio, **384–385**, 1253, 1496,  
 1497, 1832  
 Delinquency. *See* Criminology  
 Delirium, 1413, 1418  
 Delusions, 21, **385–386**  
 constructions and, 337, 338  
 cryptomnesia and, 356  
 erotomania, 521–522, 1032, 1785–1786  
 estrangement and, 524  
 identification fantasies and, 791  
 illusion and, 797  
 need for causality and, 1119  
 paranoia and, 1228  
 of persecution, 1252  
 rationalization and, 1448  
 superego and, 1690  
*Delusions and Dreams in Jensen’s “Gradiva”*  
 (Freud), 351, **386–387**, 985  
 Abraham and, 443  
 on anxiety dreams, 103  
 applied psychoanalysis and, 107  
 archeological metaphors in, 114  
 on daydreams, 555, 1494  
 on déjà vu, 382  
 on Eros, 513  
 on fantasy, 551  
 on negative hallucination, 1124  
 on passion, 1244  
 publication of, 732

Volume 1, pp. 1–662; Volume 2, pp. 663–1344; Volume 3, pp. 1345–1892

- on repetition, 1474  
 on scientific nature of psychoanalysis, 1551
- Demand, 387–389**
- Démenti*. *See* Disavowal
- Dementia, **389–390**, 462
- Dementia praecox, 6, 389, 1053, 1232, 1540, 1652
- Demonic, 524
- Démoris, René, 1842
- Demos, John, 1393
- Denial  
 alcoholism and, 41, 42  
 defenses and, 375  
 fetishism and, 582–583  
 negation and, 1121  
 negative hallucination and, 1125  
 splitting and, 1650  
*See also* Disavowal
- Denis, Paul  
 on breastfeeding, 221  
 on death instinct, 373  
 on mastery, 1026  
*Revue française de psychanalyse* and, 1499, 1500, 1630  
 on sadism, 1526  
 Société psychanalytique de Paris and, 1631  
 on transference relationship, 1789
- Denmark. *See* Danish psychoanalysis
- Denver Psychoanalytic Society, 1641
- Dependence, 391–393**  
 addiction and, 23–24  
 anorexia nervosa and, 91  
 as basic assumption, 151, 709  
 group analysis and, 709  
 infantile neurosis and, 820  
 psychoanalyst role and, 310
- Dépersonnalisation et relation d'objet* (Bouvet), 393
- Depersonalization, **393–394**  
 “as if” personality and, 122  
 boredom and, 203  
 Bouvet on, 211  
 disintegration anxieties and, 418  
 estrangement and, 524  
 patient physical position and, 541  
 self-consciousness and, 1569
- Depression, 394–395**  
 abandonment and, 3, 394–395  
 adolescence and, 27  
 ambivalence and, 57, 394  
 anaclitic, 70–71, 397, 760  
 antinarcissism and, 1114  
 dead mother complex and, 368  
 deprivation and, 397  
 desexualization and, 399  
 essential, 523, 1409  
 guilt and, 718  
 hypochondria and, 771  
 infantile, 70–71  
 libido and, 969  
 mastery and, 1024  
 mourning and, 394, 1081  
 postnatal, 1297–1298  
 primary narcissism and, 1110  
 psychoanalytic nosography and, 1375  
 Schreber case and, 1545  
 self-mutilation and, 1573  
 suicide and, 1687  
 transference and, 368, 1780–1782  
*See also* Depressive position; Melancholia
- Depression: Comparative Studies of Normal, Neurotic, and Psychotic Conditions* (Jacobson), 883
- Dépression essentielle, La* (Marty), 523
- “Depression in the Schizophrenic” (Segal), 1709
- Depressive position, 394, **395–396**  
 anaclitic depression and, 70  
 anxiety and, 100–101, 102  
 archaic and, 112  
 combined parent figure and, 316  
 disintegration anxieties and, 418  
 early Oedipus complex and, 1188  
 emotions and, 501  
 heroic self and, 740  
 imago and, 800–801  
 infant development and, 815  
 melancholia and, 1039  
 reparation and, 1471–1472  
 Riviere-Hodgson Verrall on, 1507  
 selected facts and, 1566  
 splitting of the object and, 1642  
 thought-thinking apparatus and, 1750
- Depressive threat, 27
- Deprivation, 397–398**  
 disintegration anxieties and, 418  
 encopresis and, 504  
 frustration and, 653  
 hospitalism and, 70, 397, 760–761  
 maternal care and, 1029  
*See also* Abandonment; Environment failure
- Depth psychology  
 alchemy and, 40  
 archaic and, 112  
 Austrian psychoanalysis and, 133, 134  
 British psychoanalysis and, 695  
 German psychoanalysis and, 677  
 Derbolowsky, U., 678  
*Dérèglements de l'humeur, Les* (Delay), 383  
 Deri, Frances, 360, 992, 1529, 1734  
 Derrida, Jacques  
 on cinema, 295  
*Confrontation* and, 327, 328  
 on female sexuality, 365  
 French psychoanalysis and, 613  
 on mystic writing pad, 1160  
 philosophy and, 1271  
 on signifiers, 1605
- Desanti, Jean-Toussaint, 53, 1552
- Descartes, René  
 on doubt, 435  
 on illusion, 796
- Lacan and, 1271  
 on memory, 1043  
 philosophy and, 1268, 1270
- Pichon and, 1283  
 on psyche, 1348, 1349  
 on self-consciousness, 1569
- Descent of Man, The* (Darwin), 367, 1320
- Descobert, Simone, 138, 911
- Descombey, Jean-Paul, 42, 413
- Descoueyte, Luce, 1014
- Description. *See* Case histories
- “Désertion du capitaine Rimbaud, La” (Mijolla), 791
- Desexualization, **398–399**, 473, 1679, 1691
- Désir et la perversion, Le* (Aulagnier-Spairani et al.), 1259
- Desire  
 alcoholism and, 42  
 alienation and, 43  
 altruism and, 54  
 amentia and, 58  
 death instinct and, 372  
 Deleuze/Guattari on, 98  
 demand and, 388  
 family and, 98  
 illusion and, 796  
 Kantianism and, 905–906  
 lack of being and, 1848  
 Law of the Father and, 950  
 literature and, 987  
 maternal and, 1027  
 metonymy and, 1050–1051  
 object *a* and, 1172–1173  
 Other and, 1213



## INDEX

Volume 1, pp. 1–662; Volume 2, pp. 663–1344; Volume 3, pp. 1345–1892

- philosophy and, 1271  
 phobias and, 1272–1273  
 pictogram and, 1286  
 pleasure principle and, 1290  
 primary need and, 1316  
 primary/secondary processes and, 1317  
 prohibition and, 1331  
 representation and, 781–782  
 reverie and, 555  
 sexuation and, 1595  
 signifier/signified and, 1606  
 signifying chain and, 1607  
 subject and, **1677–1678**  
 subject's castration and, 1676  
 Thing and, 1743  
 transgression and, 1791–1793  
*See also* Graph of Desire; Libido; Wish-fulfillment  
*Desire and Its Interpretation* (Lacan), 1172  
 Desnos, Robert, 1696  
 Desoille, Robert, **399–400**, 414, 555, 1494  
 Despair, 1571  
*Destins du plaisir, Les: Aliénation, amour, passion* (Aulagnier), 130, 918  
 “Destruction as the Cause of Becoming” (Spielrein), 1518  
 Destructive drives  
 anality and, 72  
 cruelty and, 355  
 orality and, 1202–1203, 1205  
 repetition compulsion and, 1475  
 skin and, 1612  
 transference hatred and, 1781  
*See also* Death instinct; Oral-sadistic stage  
 Destructuring of thought, 72–73  
 Destrudo, 372, **400**, 1854  
 Destutt de Tracy, Antoine, 795  
 “Detaching a Syndrome of Anxiety Neurosis from Neurasthenia” (Freud), 364, 420, **1135–1138**, 1335, 1878  
 Determinism, 378, **400–402**  
 Detienne, Marcel, 574  
 Détienne, Marcel, 1628  
 Detroit Psychoanalytic Society, 1658, 1659  
 Detski Dom, **402–403**, 1515, 1518, 1544  
*Deuil pathologique, Le* (Lagache), 936  
 Deuticke, Franz, **403–404**, 884  
 Deuticke, Hans, 404  
 Deutsch, Felix, **404**  
 on *American Imago*, 60  
 Boston Psychoanalytic Society/Institute and, 207, 208  
 Deutsch-Rosenbach and, 404, 405  
 Hartmann and, 727  
 Rank-Minzer and, 1444  
*Revue française de psychanalyse* and, 1498  
 Vienna Ambulatorium and, 959  
 Wiener psychoanalytische Vereinigung and, 1857, 1858  
 Deutsch-Rosenbach, Helene, **404–406**  
 Abraham, Karl and, 5  
 on “as if” personality, 72, 122, 138, 191, 405, 972  
 Boston Psychoanalytic Society/Institute and, 207  
 Croatian psychoanalysis and, 1884  
 on false self, 1646  
 on fate neurosis, 556–557  
 on female sexuality, 571, 1186  
 on femininity, 1400–1401  
 Foulkes and, 601  
 Hartmann and, 727  
 Hungarian School and, 766  
 on imposter, 803  
 Kris and, 924  
 on latent dream thoughts, 947  
 Lehrinstitut der Wiener psychoanalytischen Vereinigung and, 959  
 Mahler-Schönberger and, 1001  
 on neurotic defenses, 1142  
 photograph of, I:pl.18  
 Rank-Minzer and, 1444  
 Ross and, 1516  
 Swedish psychoanalysis and, 1698  
 Tausk and, 1727  
 Vienna Ambulatorium and, 568  
 Wagner-Jauregg and, 1846  
 Wiener psychoanalytische Vereinigung and, 1857, 1858  
 Deutsche Gesellschaft für Psychoanalyse, Psychotherapie, Psychosomatik und Tiefenpsychologie, 677  
 Deutsche psychoanalytische Vereinigung (DPV), 677, 679, 852, 1084, 1085, 1602, 1644  
 Schultz-Hencke and, 1547  
 Deutsche Psychoanalytische Gesellschaft (DPG), 42  
 Berliner Psychoanalytische Poliklinik and, 164  
 Boehm and, 199  
 Fenichel and, 579  
 founding of, 675  
 German psychoanalysis and, 1060  
 Happel and, 725  
 International Federation of Psychoanalytic Societies and, 852  
 International Psychoanalytical Association and, 856, 1060  
 medicine and, 678–679  
 Nazi Germany and, 675–677, 1085, 1644  
 neopsychoanalysis and, 679, 1131  
 postwar reestablishment of, 677, 856  
 Schultz-Hencke and, 1547  
 Spanish psychoanalysis and, 1637  
 Spitz and, 1641  
 Deutsches Institut für Psychologische Forschung und Psychotherapie (Göring Institute), 133, 164, 166, **406–407**  
 Boehm and, 199, 406, 676, 689  
 Caruso and, 248  
 French psychoanalysis and, 609  
 Göring and, 406, 676, 689, 1547, 1557  
 Kemper and, 214, 1505  
 Laforgue and, 609, 934  
 Müller-Braunschweig and, 406, 676, 1085  
*Psyche* and, 1351  
 Rittmeister and, 406, 1505–1506  
 Schultz-Hencke and, 406, 676, 1547  
 Second World War and, 1557  
 Wiener psychoanalytische Vereinigung and, 1858  
*Deux Sources consciente et inconsciente de la vie morale, Les* (Odier), 1183  
*Deuxieme sexe, La* (de Beauvoir), 576  
*Development of Psycho-Analysis* (Ferenczi and Rank), **407**, 580–581, 979–980  
*Development of the Psycho-Analytical Theory of the Psychoses, The* (Rickman), 1501, 1502  
 “Development of War, The” (Money-Kyrle), 1070  
 Developmental disorders, **408–409**  
 Developmental point of view. *See* Genetic point of view  
 Developmental processes, **1329–1331**  
*Developments in Psychoanalysis* (Heimann and Riviere), 392  
 Devereux, Georges, 93, 153–154, **409–410**, 527  
 on counter-Oedipus, 1465  
 on individual, 810  
 Röheim and, 1510  
 Schlumberger and, 1542  
 on transcultural perspectives, 1775  
 Di Vitto, Barbara, 1304  
*Diagnostic and Statistical Manual of Mental Illness (DSM)*, 824, 828, 993, 1138, 1178–1179, 1804  
 Diagnostic profile, 724

Volume 1, pp. 1–662; Volume 2, pp. 663–1344; Volume 3, pp. 1345–1892

- Dialectic of Sex, The: The Case for Feminist REvolution* (Firestone), 576
- “Dialectical Materialism and Psychoanalysis” (Reich), 1017–1018
- Diarrhea, 66
- Diary of My Analysis with Freud* (Blanton), 192, 541, 835
- Dias, Flávio, 214, 919
- Diathesis-stress model of schizophrenia, 1541
- Diatkine, Gilbert, 1630, 1631
- Diatkine, René, **410–411**
- on anaclitic depression, 70
  - Association de santé mentale and, 610
  - Belgian psychoanalysis and, 157
  - CCTP and, 264
  - Centre Alfred-Binet and, 263, 410, 955
  - Centre de diagnostic et de traitements psychanalytiques and, 609
  - on character, 274
  - child analysis and, 280, 411, 610, 613, 955, 1731, 1732
  - Colloque sur l’ inconscient and, 314
  - Congrès des psychanalystes de langue française des pays romans and, 330
  - on developmental disorders, 408
  - on developmental processes, 1330
  - on indications/contraindications for psychoanalysis, 809
  - on infantile psychosis, 825, 826
  - Kestemberg-Hassin and, 911
  - Lebovici and, 954
  - Martiničan psychoanalysis and, 1014
  - on maternal reverie, 1031
  - Nacht and, 410, 1102
  - on object, 1168
  - on pregenital stage, 1186
  - on prepsychosis, 1306
  - Racamier and, 1435
  - Revue française de psychanalyse* and, 1500
  - Société psychanalytique de Paris and, 410, 411, 1625, 1628, 1630
  - on stammering, 1653
  - Swiss psychoanalysis and, 1701
- Diaz Conti, Ricardo, 1052
- Dicks, Henry V., 1457, 1728
- Dictionary of Psychology* (Warren), 1553
- Dictionnaire de psychanalyse et de psychotechnique*, 742, 934
- Didier-Weill, Alain, 347
- Die Sprache des Traumes* (Stekel), 1657
- Die Träume der Dichter* (Stekel), 1657
- Diercks, Christine, 133
- Differentiation. *See* Lack of differentiation
- “Differentiation between Concrete and Metaphorical Thinking in the Recovering Schizophrenic Patient, The” (Searles), 786
  - “Differentiation of the Psychotic from the Non-psychotic Personalities, The” (Bion), 188, 1417
  - “Difficulty in the Path of Psycho-Analysis, A” (Freud), 366, 483
- Dilthey, Wilhelm, 181, 704, 1699
- Dionysus, 41
- Dipsomania, **412–414**
- Direct analysis, **414**
- Direct observation. *See* Infant observation
- Directed daydreams, **414–415**, 1494
- Disappointment, 782
- Disavowal, **415–417**
- consciousness and, 334
  - ego and, 466
  - negation and, 1121
  - psychotic defenses and, 1413
  - structural theories and, 1667
  - work of the negative and, 1129
  - See also* Denial
- Discharge, **417–418**
- acting out and, 10, 418
  - constancy principle and, 1322
  - excitation and, 533, 534
  - primary/secondary processes and, 1317, 1318
  - self-mutilation and, 1573
  - thought and, 1747
- Discontinuity, autism and, 137
- Discours psychanalytique*, 1084
- Discourse, 601–602, 813, 931
- Discovery of the Unconscious, The: The History and Evolution of Dynamic Psychiatry* (Ellenberger), 497
- Disillusionment, 1750–1751
- Disintegration anxieties, 90, **418**, 605, 1320
- Disintegration products, **419**
- Dismantling, 137, **419–420**
- Disorganization, **420–421**, 1460
- Displacement, **421–422**
- action-presentations and, 13
  - anxiety and, 101
  - cathexis and, 260
  - condensation and, 324
  - conscious processes and, 333
  - day’s residues and, 367
  - dreams and, 437, 438, 441, 442
  - forgetting and, 597
  - formations of the unconscious and, 598
  - letter and, 961–962
  - metonymy and, 1050
  - neurotic defenses and, 1142
  - primary/secondary processes and, 1318
  - representability and, 1477
  - screen memories and, 1555
  - secondary revision and, 1559
  - signifier/signified and, 1606
  - slips of the tongue and, 1616
  - stranger anxiety and, 1664
  - subject’s desire and, 1677
  - substitute formations and, 1681
- Displacement of the transference, **422–423**
- “Disposition to Obsessional Neurosis, The” (Freud)
- on anal eroticism, 514
  - on anality, 72
  - on character, 269
  - on choice of neurosis, 288
  - Hirschfeld, Elfriede and, 746–747
  - on obsessional neurosis, 1179
  - on organization, 1208
  - on paraphrenia, 1234
  - on pregenital organization, 1301
- Disque vert, Le*, **423–424**, 607
- Disséminaire, Le* (Videman), 1835
- Dissociation, 1645, 1646, 1672
- “Dissolution of the Oedipus Complex, The” (Freud), 1185
- on castration complex, 252–253
  - on identification, 789
  - on penis envy, 1246
  - publication of, 641
  - on repression, 1480
- “Dissolutions de la mémoire” (Delay), 383
- Distance relation, Bouvet on, 211
- “Disturbance of Memory on the Acropolis, A” (Freud), **424–425**
- on déjà vu, 381, 382
  - on depersonalization, 393
  - on disavowal, 416
  - on estrangement, 524
- Freud, Jakob Kolloman and, 625
- Freud’s self-analysis and, 638
- on illusion, 796
  - on memory, 1043
  - Rolland and, 424–425, 638, 1182, 1511
- Divided attention, 127
- Divided Self, The* (Laing), 699, 937–938
- Divine Comedy* (Dante), 986
- “Do delírio em geral” (Franco da Rocha), 614
- Do mito à verdade científica: Estudos psicanalíticos* (Martins), 1015

## INDEX

Volume 1, pp. 1–662; Volume 2, pp. 663–1344; Volume 3, pp. 1345–1892

- Doane, M. A., 294
- Döblin, Alfred, 674
- Doctor, His Patient and the Illness, The* (Balint), 149, 151
- Doctor and the Soul, The* (Frankl), 615
- Doctors of Infamy: The Story of the Nazi Medical Crimes* (Mitscherlich), 1060–1061
- Documents et Débats* (APF), 123, 124, **426**
- Dogma of Christ and Other Essays on Religion, Psychology, and Culture, The* (Fromm), 1017
- Doi, Takeo, 56, 887, 888
- Dolto-Marette, Françoise, **426–429**
- Armand Trousseau Children's Hospital and, 120, 427
- Belgian psychoanalysis and, 158
- Berge and, 161
- Bloc, Le—Notes de la psychanalyse* and, 195
- Centre psychopédagogique Claude-Bernard and, 265
- child analysis and, 280, 427–428, 592–593, 610, 1347, 1732
- on deprivation, 397
- Desoille and, 400
- French psychoanalysis and, 613
- French psychoanalytic establishment split (1953) and, 427, 560, 930, 1619
- French psychoanalytic establishment split (1964) and, 427, 957
- on gaze, 990
- IPA excommunication, 162, 327, 427, 455, 611, 692
- Laforgue and, 934, 1625
- on modesty, 1067
- Morgenstern-Kabatschnik and, 427, 1073, 1346
- Pankow and, 1222
- Peraldi and, 1247
- Psychanalyse et Pédiatrie*, 1346–1347
- Psyché* and, 1350
- psychological tests and, 1395, 1398
- on puberty, 1421
- Schilder and, 1538
- Schlumberger and, 1541
- on self-image, 1572
- on transitional phenomena, 1794
- on weaning, 1851, 1852
- Domingues de Morais, Maria Regina, 217
- Domínguez, Hugo, 1832, 1833
- Dominique: the analysis of an adolescent* (Dolto-Marette), 427
- Don Juan* (Rank), **429**
- Dongier, Maurice, 314
- Donnars, Jacques, 934
- Donnet, Jean-Luc
- on blank psychoses, 191
- CCTP and, 264
- on frame of psychoanalytic treatment, 606
- Inconscient, L'* and, 807
- on intergenerational phenomena, 846
- Société psychanalytique de Paris and, 1626, 1630
- on transference, 1781
- Doolittle-aldington, Hilda (H.D.), **429–431**
- Dopamine hypothesis, 1540
- Dor, Joël, 578
- “Dora” case, **604–605**
- acting out and, 10, 605
- adolescence and, 26
- anxiety dreams and, 103
- conversion and, 345
- cruelty and, 354
- dreams of mourning and, 1083
- enuresis and, 507
- flight into illness and, 590
- free association and, 616
- gain and, 664
- hysteria and, 772
- identification and, 787, 788
- latent dream thoughts and, 948
- Oedipus complex and, 1184
- partial drives and, 1240
- repetitive dreams and, 1476
- resistance and, 1384
- rituals and, 1503
- somatic compliance and, 1635
- transference and, 1384, 1776–1777
- unary trait and, 1814
- urethral eroticism and, 517
- Dorer, Maria, 82
- Dorey, Gabrielle, 1430
- Dorey, Roger, 563, 729, 1024, 1025
- Dorn, Gérard, 811
- Dos Santos, João, 1297
- Dos sueños de analistas* (Langer), 941
- Dostoyevsky, Fyodor, 23, 431–432, 1515
- “Dostoyevsky and Parricide” (Freud), 351, 412, 413, **431–432**, 985, 1071–1072, 1238
- Dosuzkov, Theodor N., 361, **432–433**, 1212, 1292
- Double, the, 429, 434, **434–435**, 1106, 1815
- Double, The* (Rank), **429**
- Double bind, **433–434**, 1720
- Doublethink, 111
- Doubrovsky, Serge, 327
- Doubt, 265, **435–436**, 549
- Doucet, Pierre, 245
- Douki, Saïda, 1155, 1156
- Doumic-Girard, Alice, 1004
- Douville, Olivier, 1156
- Doyle, Arthur Conan, 1181
- Doyle Ferreira, Iracy, 215
- DPG. *See* Deutsche Psychoanalytische Gesellschaft
- DPV. *See* Deutsche psychoanalytische Vereinigung
- Dr. Mabuse* (film), 292, 293
- Dracoulides, Nicolas, 700
- Dräger, Käthe, 676
- “Dragons and Dragon Killers” (Röheim), 1509
- Drang*. *See* Pressure
- Drazien, Muriel, 880
- Dream-confusion disorders, 21
- Dream interpretation, **438–439**, **864–865**
- hermeneutics and, 738
- Kemper, Werner Walther on, 910
- translation and, 1797–1798
- wish-fulfillment and, 1865
- See also* Dream work; Dreams; Interpretation
- Dream-like memory, **439–440**
- “Dream of the Wise Baby, The” (Freud), **440**
- Dream screen, **440–441**
- Dream symbolism, 437, **441–442**, 1798, 1811
- Dream work, 436, 437, **442–443**
- See also* Dreams
- Dreams, **436–438**
- action-presentations and, 12
- adolescence and, 27
- alchemy and, 40
- amentia and, 58
- amnesia and, 64
- amplification and, 67, 865
- anagogical interpretation and, 71
- anticipatory ideas and, 95
- anxiety dreams, 102–103, 1150
- archaic and, 112, 1007
- archetypes and, 115
- birth in, 185–186
- ensorship in, 262
- certainty and, 265
- cinema and, 293, 295
- condensation and, 324–325
- conflict and, 325
- contradiction and, 341
- of convenience, 344–345

Volume 1, pp. 1–662; Volume 2, pp. 663–1344; Volume 3, pp. 1345–1892

- daydreams and, 555, 1494  
 day's residues and, 367–368, 437, 438, 442  
 death and, 370, 1810–1811  
*Delusions and Dreams in Jensen's "Gradiva"* and, 386–387  
 determinism and, 401  
 displacement and, 421–422  
 doubt and, 435  
 "Dream of the Wise Baby, The" on, 440  
 ego and, 462  
 examination dreams, 533, 1811  
 fantasy and, 550  
 Freud's self-analysis and, 436, 438, 533  
 Garma on, 666, 1366–1367  
 German romanticism and, 673  
 hypocritical, 771–772  
 hysteria and, 773  
 incompleteness and, 805  
 infantile and, 830  
 infantile omnipotence and, 822  
 jokes and, 890  
 latent/manifest dream elements, 437, 438, 442, 489, 946–947, 948, 1007, 1007–1008, 1747  
 logic and, 989–990  
 maternal and, 1028  
 "Metapsychological Supplement to the Theory of Dreams, A" on, 1048  
 mnemonic traces and, 1063  
 of mourning, 1083  
 mourning and, 1081, 1082  
 mythology and, 443, 1099  
 of nakedness, 1103, 1810  
 narcissistic withdrawal and, 1116  
 night terrors and, 1149  
 nightmares, 102–103, 1149–1150  
 overdetermination and, 1216  
 phobias and, 1275  
 premonitory, 1305  
 primary/secondary processes and, 1318  
 primitive words and, 4  
 projection and, 1336  
 psychic temporality and, 1359  
 of punishment, 1422–1423, 1577  
 regression and, 1459  
 repetitive, 1476  
 representability and, 1477  
 reversal into the opposite and, 1494–1495  
 screen memories and, 1555  
 self-state, 1579  
 Silberer on, 1608  
 sleep/wakefulness and, 1614–1615  
 slips of the tongue and, 1616  
 somnambulism and, 1636  
 subject's desire, 1677  
 substitute formations and, 1680  
 surrealism and, 1695  
 symbolism and, 437, 441–442, 1798, 1811  
 symbolization and, 441, 442, 654–655  
 thought and, 1747  
 transgression and, 1793  
 wish-fulfillment and, 1866  
*See also* Dream work; Secondary revision  
 "Dreams and Myths" (Abraham), 5, 443, 1099  
 "Dreams and Telepathy" (Freud), 1181, 1476, 1488, 1735  
 "Dreams in Folklore" (Freud), 564  
 Dream's navel, 443, 1453  
 Dreams of convenience. *See* Convenience, dreams of  
*Drei aufsätze über den inneren Konflikt* (Gross), 708  
*Drei Grundelemente des wissenschaftlichen Denkens bei Freud, Die* (Binswanger), 181  
*Dressed to Kill* (film), 292  
 Drive regression, 1687  
 Drives, 444–448  
   action-presentations and, 13  
   activity/passivity and, 17  
   adolescence and, 28, 29  
   aggression and, 34, 35  
   anaclisis and, 69  
   analytic psychodrama and, 78  
   anticathexes and, 94  
   *Beyond the Pleasure Principle* on, 173–175  
   breast as good/bad object and, 220  
   compulsion and, 322, 323  
   cruelty and, 354  
   culture and, 297  
   dualism and, 449  
   ego autonomy and, 474  
   emotions and, 501  
   ethology and, 528  
   excitation and, 534  
   Fairbairn on, 545  
   fixation and, 588  
   idealization and, 783  
   identity and, 795  
   "Instincts and Their Vicissitudes" on, 446, 838, 1674  
   instinctual representative and, 841  
   jouissance and, 894  
   mastery and, 1026  
   object and, 1171  
   object relations theory and, 447, 1176, 1177  
   objects and, 1168  
   operational thinking and, 1198  
   partial drives, 1239–1241, 1257–1258  
   politics and, 1293  
   psychic energy and, 1356  
   psychosexual development and, 1406  
   Schiller on, 1539  
   Schur on, 1548  
   scientific nature of psychoanalysis and, 726  
   self and, 1580  
   self-preservation and, 1575  
   self psychology and, 1576  
   sexualization and, 1595  
   splitting and, 1646  
   subject of the unconscious and, 1675  
   termination of treatment and, 76, 77  
   work of the negative and, 1129  
*See also* Death instinct; Life instinct; Sexual drives; Sexuality  
 Dromomania, 412  
 Drug treatments. *See* Psychopharmacology  
 Drumont, Édouard, 1437  
 Druon, Catherine, 1304  
 Du Bois-Reymond, Emil, 637  
 "Du langage pictorial au langage de l'interprété" (Aulagnier-Spairani), 1477  
 Dualism, 448–449  
   activity/passivity and, 17  
   antinarcissism and, 97  
   *Beyond the Pleasure Principle* on, 174  
   change and, 267  
   conscious processes and, 333  
   contradiction and, 341–342  
   desexualization and, 399  
   drives and, 445–446  
   German romanticism and, 673–674  
   Klein on, 449, 1106  
   monism and, 1070–1071  
   pain and, 1219  
   transgression and, 1793  
*See also* Death instinct; Life instinct  
 Dubal, George, 195, 449–450  
 Dubal, Georges, 1556  
 Dubal, Rosette, 450  
 Dubois, Paul, 1411  
 Dubowitz, Margit, 765  
 Dufour, Roger, 415  
 Dufresne, Roger, 245, 1621, 1622  
 Dugas, Ludovic, 1569  
 Dugautiez, Maurice, 157, 450–451, 450–451, 956  
 Dührssen, Annemarie, 679, 1131

## INDEX

Volume 1, pp. 1–662; Volume 2, pp. 663–1344; Volume 3, pp. 1345–1892

- Dujarrier, Louis, 1628  
 Dukes, Géza, 356, 766  
 Dumas, Didier, 1266  
 Dumas, Georges, 305, 382, 886, 1053, 1054, 1634  
 Dumesnil, F., 1573  
 Dumézil, Claude, 1083, 1084, 1099  
 Dumézil, Georges, 1350  
 Dumont, Louis, 810  
 Dumontpallier, Victor, 331  
 Dunbar, Helen Flanders, 43, 1222, 1408  
 Duparc, François, 423, 1125, 1878  
 Dupont, M. A., 1052  
 Dupré, Ernest, 827, 1098  
 Durand, Father Charles, 156  
*Durcharbeiten*. See Working-through  
 Durkheim, Émile, 1631  
 Durrell, Lawrence, 706  
 Durst, Margarete, 1816  
 Düss, Louisa, 1395  
 Dutch psychoanalysis, **1132–1134**  
 Emden and, 498–499, 1132  
 Lampl-de Groot and, 938  
 Landauer and, 940  
 Leeuw and, 958  
 Van Ophuijsen and, 1133, 1200  
 Dutch Psychoanalytic Institute, 938  
 Dutch Society for Psychoanalysis. See Nederlandsche vereniging voor psychoanalyse  
 Dutourd, Jean, 383  
 D'Waelhens, Alphonse, 315, 1348  
 Dwelshauvers, Georges, 157, 424  
 Dynamic point of view, **451**, 1049  
 aggression and, 35  
 drives and, 447  
 neuroses and, 1138  
 psychic energy and, 1355  
 puberty and, 1421  
 repression and, 1484  
 rituals and, 1504  
 See also Metapsychology  
 “Dynamics of Transference, The” (Freud)  
 on anticipatory ideas, 95  
 on imago, 800  
 on interpretation, 862  
 on negative transference, 1127  
 on resistance, 1488  
 on resolution of the transference, 1490  
 on silence, 1610  
 on transference hatred, 1781  
 Dysmorphophobia, 1578
- E**  
 Eagle, Morris N., 1517  
 “Early Development of Female Sexuality, The” (Jones), 893  
 Early interactions, **453–454**  
 Early Oedipus complex, Klein on, 113, 219, 915, 1174, 1187, 1188  
 “Early Stages of the Oedipus Conflict” (Klein), 517  
 Eating disorders, 54, 91–92, 138, 233–234, 1202, 1578, 1665, 1686  
 Eberwein, Robert, 296  
 EBP (Escola Brasileira de Psicanálise do campo freudiano), 217  
 EBPI (École Belge de Psychanalyse Jungienne), 158  
 ECF (École de la Cause freudienne), **455–456**, 612, 931, 1083, 1519, 1644, 1645  
*Echec de Baudelaire, L'* (Laforgue), 544, 934  
 Eckstein, Emma, **454–455**, 667, 1671  
 École Belge de Psychanalyse (Belgische School voor Psychoanalyse), 158  
 École Belge de Psychanalyse Jungienne (EBPJ), 158  
 École de la Cause freudienne (ECF), **455–456**, 612, 931, 1083, 1519, 1644, 1645  
 École de psychanalyse Sigmund Freud, 456  
 École expérimentale de Bonneuil, **456–457**  
 École freudienne, 1084  
 École freudienne de Paris (Freudian School of Paris), **457–458**, 611  
 Certeau and, 266  
 dissolution of, 612, 931, 1083–1084, 1630, 1631, 1645  
 founding of, 129, 427, 455, 457, 506, 611, 930  
 Italian psychoanalysis and, 880  
 Mannoni and, 1009  
 Miller and, 458, 612  
 pass and, 1242, 1251, 1430  
 Peraldi and, 1247  
 Perrier and, 457, 458, 1251  
 Quatrième Groupe and, 1429–1430  
 training analysis and, 1770  
 See also French psychoanalytic establishment split (1964)  
 École Lacanienne de psychanalyse (ELP), 612, 1084  
 École psychosomatique de Paris, 1016, 1198, 1876  
 Economic point of view, **458–459**, 1049  
 aggression and, 35  
 collective psychology and, 311  
 constancy principle and, 1323  
 derivatives of the repressed and, 1481  
 discharge and, 417  
 drives and, 446–447  
 empathy and, 502  
 excitation and, 533, 534  
 fixation and, 588  
 humor and, 762  
 jokes and, 890, 891  
 language and, 1874  
 libido and, 968–969  
 mourning and, 1081, 1082  
 negative therapeutic reaction and, 1126  
 neuroses and, 1138  
 operational thinking and, 1198  
 perception-consciousness system and, 1248  
 primary/secondary processes and, 1318  
 psychic energy and, 1355, 1356  
 puberty and, 1421  
 repression and, 1483–1484  
 trauma and, 1455, 1801  
 traumatic neuroses and, 1804  
 unpleasure and, 1826–1827  
 See also Metapsychology  
 “Economic Problem of Masochism, The” (Freud)  
 on conflict, 326  
 on death instinct, 372  
 on ego, 465  
*Ego and the Id, The* and, 472  
 on erotogenic masochism, 517–518, 1021  
 on excitation, 1753  
 on feminine masochism, 572, 1258  
 on fusion/defusion, 658  
 on identification, 789  
 on imago, 800  
 on masochism, 1021–1022  
 on moral masochism, 1071  
 on negative therapeutic reaction, 1126  
 on Nirvana principle, 1151–1152  
 on oral eroticism, 516  
 on pairs of opposites, 1220  
 on perversion, 1258  
 on pleasure principle, 1291  
 on punishment dreams, 1423  
 on quantitative/qualitative dimensions, 1428  
 on sadism, 1526  
 on sadomasochism, 1527  
 on turning around, 1807  
*Écrit du temps, L'*, 124, 611  
*Écrits* (Lacan), 37, 38, **459–460**, 571, 611, 612, 930–931, 1552, 1668

Volume 1, pp. 1–662; Volume 2, pp. 663–1344; Volume 3, pp. 1345–1892

- ECRO (*Esquema Conceptual Referencial y Operativo*), 1285
- Eczema, 1665
- Ecumbe, Rose, 577
- Eder, David Montagu, **460–461**  
 British psychoanalysis and, 695, 696, 697  
 Israeli psychoanalysis and, 876  
 Jung and, 460, 461, 695  
 Low and, 997
- Edinger, Edward, 80
- Éducation et psychothérapie institutionnelle* (Tosquelles), 1766
- Éducation familiale, L'* (Berge), 162
- Educational Monograph Series* (IPA), 858, 859
- Effort, L'*, 196
- EFP. *See* École freudienne de Paris
- EFPP (European Federation for Psychoanalytic Psychotherapy), 1412
- Ego, **461–468**  
 abandonment and, 2, 3  
 activity/passivity and, 17  
 adaptation and, 375, 475, 488  
 adolescence and, 26, 29  
 aggression and, 34–35  
 Alexander, Franz Gabriel on, 43  
 allergic object relationship and, 47  
 alteration of, 76, **468–469**  
 amnesia and, 64  
 amphimixia and, 66  
 amplification and, 67  
 anaclitic depression and, 70  
 analytical psychology on, 463, **469–470**  
 antilibidinal, 96–97  
 basic fault and, 152  
 belief and, 158  
 binding/unbinding and, 179  
 blank psychoses and, 191, 192  
 breast as good/bad object and, 219  
 capacity to be alone and, 247  
 cathexis and, 260  
 censorship and, 263  
 character and, 269, 273, 274  
 children's play and, 283  
 choice of neurosis and, 288  
 collective unconscious and, 313  
 compensation and, 317  
 concept development, 461–466, 475–476  
 consciousness and, 334  
 conversion and, 345  
 counter-identification and, 348  
 cruelty and, 355  
 cultural transmission and, 357  
 damage inflicted on, 475  
 death instinct and, 372, 464  
 defenses and, 374, 375, 376, 377  
 depersonalization and, 393  
 depression and, 394, 395  
 depressive position and, 396  
 dipsomania and, 413  
 disavowal and, 415, 416  
 double and, 434  
 dualism and, 449  
*Ego and the Id, The* on, 464–465, 470, 471–472, 476  
 ego boundaries and, 474  
 ego psychology on, **475–477**  
 ego states and, 488–489  
 envy and, 509  
 Erikson on, 282  
 Eros and, 513  
 experience of satisfaction and, 536  
 externalization-internalization and, 537  
 Fairbairn on, 545  
 fascination and, 556  
 Freud, Anna on, 466, 472–473, 476, 477  
 frustration and, 654  
 functions of, 476–477, **478–479**, 482  
 groups and, 712  
 guilt and, 470, 471, 716, 717  
 humor and, 762–763  
*I* and, 775  
 id and, 777  
 idealization and, 783–784  
 identity and, 481–482, 511, 794  
 imaginary and, 799  
 infant development and, 815  
 infantile omnipotence and, 823  
 inhibition and, 833  
 internal objects and, 849  
 introjection and, 870  
 Lacan on, 463, 467, 475, 929  
 “Little Hans” case and, 75–76  
 masochism and, 1022  
 maternal and, 1027  
 melancholia and, 21, 1038, 1039  
 mourning and, 3  
 mystic writing pad and, 1158–1159  
 narcissism and, 1106, 1107  
 narcissistic defenses and, 1111  
 narcissistic neuroses and, 1113–1114  
 negative therapeutic reaction and, 1127  
 object and, 70  
 passage to the act and, 18  
 perception-consciousness system and, 1248–1249  
 primary object and, 1317  
 prohibition and, 1332  
 protective shield and, 1340  
 psychic structure and, 1358  
 psychogenic blindness and, 1392–1393  
 psychoses and, 1404  
 psychosomatic limit and, 1410  
 reality testing and, 1451  
 regression and, 1460  
 repression and, 1479, 1480  
 rituals and, 1504  
 Sartre on, 1534–1535  
 screen memories and, 1556  
 secrets and, 1560  
 self and, 1567, 1568  
 self-consciousness and, 1569–1570  
 self-esteem and, 1570  
 self-image and, 1571  
 self-mutilation and, 1572–1573  
 self-preservation and, 1575, 1576  
 self-punishment and, 1577  
 self-representation and, 1578  
 skin and, 1613  
 somnambulism and, 1636  
 Spitz on, 1641  
 splitting of the object and, 1642, 1648  
 stages and, 1651  
 state of being in love and, 1656  
 subject and, 1673  
 substitute formations and, 1680  
 superego and, 465, 1690  
 symptoms and, 1715  
 synthetic function of, 476–477, 478, 479, 482  
 true/false self and, 1581  
 turning around and, 1807  
 Winnicott on, 1862  
*See also* Skin-ego; Splitting of the ego; Structural theory  
*Ego and the Id, The* (Freud), 174, **470–472**, 640  
 on aggression, 34  
 on bisexuality, 187  
 on cathectic energy, 259  
 on character, 272  
 collective psychology and, 311  
 on cultural transmission, 357  
 on cure, 359  
 on death instinct, 372  
 on defenses, 375  
 on destrudo, 400

## INDEX

Volume 1, pp. 1–662; Volume 2, pp. 663–1344; Volume 3, pp. 1345–1892

- on ego, 464–465, 470, 471–472, 476  
 on ego ideal, 479–480  
 ego psychology and, 486  
 on fusion/defusion, 658, 659  
 Groddeck and, 777  
 on guilt, 717  
 on id, 777–778  
 on infant development, 814, 815  
 on life instinct, 975  
 on melancholia, 21  
 on moral masochism, 1071  
 on narcissism, 1105, 1106  
 on negative therapeutic reaction, 1125–1126  
 on object, 1169  
 on orality, 1202  
 on otherness, 1214  
 on pain, 1219  
 on perception-consciousness system, 1248  
 on primary identification, 1313  
 psychic energy and, 1356  
 on psychic representative, 1358  
 on secondary narcissism, 1111  
 on self-hatred, 1571  
 on stratification, 1665  
 on superego, 471, 479, 1690  
 on suppression, 1694  
 on topographical point of view, 1760  
 U.S. psychoanalysis and, 1825  
 on working-off mechanisms, 1877  
*See also* Structural theory  
*Ego and the Mechanisms of Defense, The* (Anna Freud), 54, 466, 472–473, 619, 792, 1387, 1808  
 Ego autonomy, 466, 473–474, 477  
 Ego boundaries, 474–475, 477–478, 487–488  
 Ego cathexis, 474, 487  
 Ego collapse, 1687  
 Ego-consciousness, 1569–1570  
 “Ego Distortion in Terms of True and False Self” (Winnicott), 1567, 1582  
 Ego feeling, 474, 477–478, 487, 489  
 Ego ideal, 479–480  
 alienation and, 44, 480  
 “as if” personality and, 122  
 ego and, 463  
 groups and, 712  
 ideal ego and, 481  
 idealization and, 783, 784  
 idealized parental imago and, 784  
 identification and, 788, 789  
 identificatory project and, 793  
 imaginary and, 799  
 mania and, 1006, 1007  
 mastery and, 1024  
 megalomania and, 1036  
 narcissism and, 1105, 1106  
 narcissistic injury and, 1113  
 object and, 1169  
 primary narcissism and, 1110  
 prohibition and, 1332  
 secondary narcissism and, 1110–1111  
 self-esteem and, 1570  
*See also* Ideal ego  
 Ego identity, 481–482, 511, 794, 1324  
 “Ego in Freud’s Theory and in the Technique of Psychoanalysis, The” (Lacan), 467, 1453  
 Ego-instincts, 56, 445, 482–484, 975, 1119  
 “Ego-integration in Child Development” (Winnicott), 843  
 Ego interests, 484  
 Ego-libido/object-libido, 463, 484–486, 968  
 ego-instincts and, 483  
 erotogenic zones and, 519  
 hypochondria and, 770  
 identificatory project and, 793  
 mourning and, 1081  
 object *a* and, 1173  
 objects and, 1168  
 “On Narcissism” on, 1191  
 puberty and, 1420  
 self-esteem and, 1570  
 sublimation and, 1678  
 turning around and, 1807  
 Ego psychology, 486–487  
 on adaptation, 22, 475, 989  
 alteration of the ego and, 469  
 Arlow and, 119  
 Bettelheim and, 173  
 cathexis and, 260  
 on defenses, 375  
 definition of psychoanalysis and, 1364  
 development of, 466  
 Dutch psychoanalysis and, 1134  
 on ego, 475–477  
 on ego feeling, 474, 477–478  
 on ego functions, 478  
 on ego syntony, 489–490  
 Federn, Paul and, 466, 475, 476, 477, 487–488, 568  
 Finnish psychoanalysis and, 584  
 Freud, Anna and, 473  
 Hartmann on, 466, 475, 476, 477, 488, 727, 728  
 on id, 779  
 on identity, 794  
 inferiority feelings and, 831  
 on It, 201  
 Kardiner and, 906  
 Kris and, 925  
 Lampl-de Groot and, 938–939  
 Loewenstein and, 989  
 metapsychology and, 1049  
 Nacht and, 1103  
 New York Psychoanalytic Institute/Society and, 1148  
 on projective identification, 1339  
 on psychic energy, 1356  
 psychology and psychoanalysis and, 1397  
 on psychosexual development, 1407  
 Rapaport on, 1446  
 on representation, 781  
 self psychology and, 1576  
 stages and, 1652  
 structural theories and, 1667  
 U.S. psychoanalysis and, 1825  
 Wiener psychoanalytische Vereinigung and, 1857  
*Ego Psychology and the Problem of Adaptation* (Hartmann), 22, 273, 488, 727  
*Ego Psychology and the Psychoses* (Federn), 487–488, 568  
 Ego states, 474, 488–489, 568  
 Ego syntony, 489–490  
 Egotism, 355  
 Egyptian mythology, 1096  
 Ehrenzweig, Anton, 1842  
 Eicholz, Enid. *See* Balint, Enid  
 Eiferman, Rivka, 877  
 Eight-month anxiety, 1186, 1664  
 Eiguer, Alberto, 845, 846  
 Eiminder, Sándor, 1765  
*Einfälle*. *See* Sudden involuntary ideas  
*Einführung*. *See* Empathy  
*Einführung in die Psychoanalyse* (Schultz-Hencke), 1130  
*Einige Ideen zur Schöpfungs- und Entwicklungsgeschichte des Organismen* (Fechner), 565  
*Einleitung in ein Aegyptisch-semitisch indoeuropäisches Wurzelwörterbuch* (Abel), 3  
 Einstein, Albert, 1378, 1550  
*See also* “Why War?”  
 Eisler, József, 765, 766  
 Eissler, Kurt Robert, 490–491  
 Eissler-Selke and, 492

Volume 1, pp. 1–662; Volume 2, pp. 663–1344; Volume 3, pp. 1345–1892

- Italian psychoanalysis and, 879  
*Journal of the American Psychoanalytic Association*, 897  
 Lampl-de Groot and, 938  
 New York Psychoanalytic Institute/Society and, 1148  
 on pleasure in thinking, 1289  
*Sigmund Freud: Life and Work* and, 974  
 Sigmund Freud Archives and, 490, 491, 642, 1600  
 Tausk and, 1727  
 Vienna Ambulatorium and, 959  
 “Wolf Man” case and, 1221  
 Eissler-Selke, Ruth, **491–492**, 919  
 Eitingon, Max, **492–494**, 638  
 Benedek and, 159  
 Berggasse 19, Wien IX and, 162  
 Berliner Psychoanalytische Poliklinik and, 164, 492, 493, 675  
 Berliner Psychoanalytisches Institut and, 165, 166  
 Brazilian psychoanalysis and, 1012  
 Burghölzli Asylum and, 180  
 Congrès des psychanalystes de langue française des pays romans and, 330  
 on counter-transference, 747  
 Deutsche Psychoanalytische Gesellschaft and, 675, 676  
 Dutch psychoanalysis and, 1132–1133  
 German psychoanalysis and, 674, 675  
 Happel and, 725  
 International Psychoanalytical Association and, 854, 855  
*Internationale Zeitschrift für Psychoanalyse* and, 860  
 Israeli psychoanalysis and, 461, 876, 1881  
 lay analysis and, 855, 951  
 “Lines of Advance in Psycho-Analytic Therapy” and, 980  
 Loewenstein and, 988  
 on occultism, 1181  
 photographs of, I:pl.19, III:pl.9  
 on psychoanalytic treatment, 1729  
 Secret Committee and, 493, 1561  
 on *Secrets of a Soul, The*, 1563  
 Swiss psychoanalysis and, 1549, 1702  
 Tegel clinic and, 1734  
 Tomasi and, 1758  
 training analysis and, 1769  
 Van Ophuijsen and, 1200  
 Eitingon, Max, 1611  
 Ekman, Tore, 1699  
 Eksterman, A., 216  
 El Khayat, Ghita, 1155  
*Élan vital*, 485  
 Elasticity, 15, 16, **494–495**, 581  
 “Elasticity of the Psychoanalytic Technique, The” (Ferenczi), 494, 1725  
 Electra, 27  
 Electra complex, 319  
 Electricity, 1181  
*Elementary Structures of Kinship, The* (Lévi-Strauss), 1774  
*Elementi di psicoanalisi* (Weiss), **495**, 878, 1853–1854  
*Elements of Psycho-Analysis* (Bion), 171, 340, 704, 705, 995, 1030, 1031, 1299  
 Elias, Norbert, 601  
 “Elisabeth von R.” case, **495–497**  
 cathartic method and, 258  
 Darwinism and, 366  
 erotogenicity and, 520  
 femininity and, 573  
 phylogenesis and, 1277  
 resistance and, 496, 1488  
 Ellenberger, Henri Frédéric, **497**  
 on “Anna O.” case, 88, 89, 1223  
 Binswanger and, 181  
 on “Emmy von N.” case, 500  
 Pfister and, 497, 1260  
 on psychotherapy, 1411  
 Ellery, Reginald S., 131  
 Ellis, Havelock, 130, 141, 695, 1257, 1671, 1751  
*Éloge de la phobie* (Birraux), 1275  
 ELP (École Lacanienne de psychanalyse), 612, 1084  
 Éluard, Paul, 37, 1695  
 Embirikos, Andreas, **498**, 700, 922, 1696  
 Emde, Robert N., 454, 888  
 Eminescu, Mihai, 1511  
 Emma case  
 memories and, 1041  
 mnemonic symbols and, 1062  
 mnemonic traces and, 1064  
 proton-pseudos and, 1342  
 screen memories and, 1555  
 trauma and, 1801  
 Emminghaus, Hermann, 827  
 “Emmy von N.” case, **499–500**, 1076–1077  
 Andersson on, 82, 497  
 cathartic method and, 258  
 complexes and, 319  
 Darwinism and, 366  
 Delboeuf and, 384  
 Ellenberger on, 497  
 free association and, 616, 1384  
 Emotions, 47, 48, 268, **500–501**  
 Empathy, **501–502**  
 counter-identification and, 348  
 elasticity and, 494  
 Ferenczi on, 59, 494, 502  
 identification and, 790  
 Kohut on, 502, 920  
 projective identification and, 1339  
 tact and, 1725  
 Empedocles of Agrigento, 356, 511–512  
 Empty behavior syndrome, 1665  
*Empty Fortress, The* (Bettelheim), 173, **502–504**  
*Encéphale, L*, 305  
*Enchanted Soul, The* (Rolland), 1511  
 Enckell, Mikael, 584  
 Encopresis, **504–505**  
*Encore* (Lacan), 1595  
 Encounter, **505–506**  
 Encounter group movement, 238  
 Encryption, 1560  
 Endorphins, 1573  
 Energy. *See* Free energy/bound energy; Psychic energy  
*Enfances* (Dolto-Marette), 426  
 “Enfant, l’infantile et la causalité psychique, L” (Brusset), 830  
*Enfant arriéré et sa mère, L* (Mannoni-Vander Spoel), 1010  
*Enfant au caractère difficile, L* (Berge), 162  
*Enfant dans l’adulte ou l’éternelle capacité de rêverie, L* (Diatkine), 1031  
*Enfant et le Psychanalyste, L* (Ferro), 1784  
*Enfant imaginaire, L* (Stein), 613  
 Engel, Pascal, 1271  
 Engel, Werner, 79  
 Engelman, Edmund, 162, 1603  
 Engels, Friedrich, 45  
 Enriquez, Eugène, 1322, 1628, 1632  
 Enriquez-Joly, Micheline, **506–507**, 846, 1560, 1626  
*Ensaïos de psicanálise* (Porto-Carrero), 1295  
*Entertaining Satan* (Demos), 1393  
*Entfremdung*. *See* Alienation  
 “Entretien avec Pierre Geissman à propos de l’observation des bébés” (Green), 818  
 Entropy, 372  
*Entwurf zu einer Psychiatrie auf psychoanalytischer Grundlage* (Schilder), 1538  
 Enuresis, **507–508**, 517, 1636  
 Environment  
 Bowlby on, 211–212



## INDEX

Volume 1, pp. 1–662; Volume 2, pp. 663–1344; Volume 3, pp. 1345–1892

- breastfeeding and, 221  
 disintegration anxieties and, 418  
 early interactions and, 453–454  
 ego autonomy and, 474  
 infantile omnipotence and, 823  
 infantile psychosis and, 826  
 narcissism and, 1107  
 pictogram and, 1287  
 pleasure ego/reality ego and, 1288  
 primitive agony and, 1320  
 protective shield and, 1340  
*See also* Environment failure; Family; Good-enough mother; Mother; Mother-infant bond
- Environment failure, 545–546, 546  
*See also* Deprivation; Environment
- Envy, 56, **508–509**, 509–510, 1203–1204  
*Envy and Gratitude* (Klein), 508, **509–510**, 1203–1204
- EPF. *See* European Psychoanalytical Federation
- Epicurus, 1290
- Epilepsy, 143, 431, 432, 985
- Epistemology, 1369–1371  
 Bion on, 184, 1451  
 interpretation and, 863  
 psychic reality and, 1357  
 realization and, 1451  
 scientific nature of psychoanalysis and, 1551
- Epistemophilia, 1679
- Erickson, Milton, 1685
- Erikson, Erik Homburger, **510–511**  
 Blos and, 196  
 on childhood, 282  
 definition of psychoanalysis and, 1364  
 on “Dora” case, 604  
 on ego, 466, 477, 481–482, 511, 1324  
 Hietzing Schule and, 745  
 on identity, 794, 795  
 on identity preservation principle, 1324  
 on infant development, 814  
 Japanese psychoanalysis and, 888  
 Mead and, 1035  
 photograph of, I:pl.20  
*Psyche* and, 1351  
 psychobiography and, 1388  
 psychohistory and, 1393  
 Rycroft and, 1521  
 San Francisco Psychoanalytic Society and Institute and, 1529  
 on self, 1567  
 on self-representation, 1578  
 on Shakespeare, 1598  
 U.S. psychoanalysis and, 1824, 1825
- Erlich, Shmuel, 877
- Ermakov, Ivan, 402, 1518, 1543, 1881
- Ernet, M., 294
- Ernst, Max, 1695–1696
- Erogenous zones. *See* Erotogenic zones
- Eros, **511–514**  
*See also* Life instinct  
*Eros and Civilization: A Philosophical Inquiry into Freud* (Marcuse), 1013, 1018
- Eroticism  
 amphimixia and, 66–67  
 breastfeeding and, 220–221  
 mother-infant bond and, 220–221, 262  
*See also* Anal eroticism; Oral eroticism; Urethral eroticism
- Erotogenic (primary) masochism, **517–518**, 1021, 1022, 1125, 1130, 1315–1316, 1475
- Erotogenic zones, **518–519**  
 anal-sadistic stage and, 73  
 body image and, 197  
 component instincts and, 1752  
 erotogenicity, 519–521  
 female sexuality and, 571  
 masturbation and, 1026  
 organ pleasure and, 1205–1206  
 organic repression and, 1207  
 sexualization and, 399  
 skin as, 1612
- Erotogenicity, **519–521**
- Erotomania, **521–522**, 1032, 1785–1786
- Erreurs et dignité de la pensée humaine* (Flournoy), 591
- Erinnerungssymbol*. *See* Mnemic symbols
- Erwartungsvorstellungen*. *See* Anticipatory ideas
- Erythrophobia, **522–523**
- Es, das*. *See* Id
- Escape from Freedom* (Fromm), 651
- Escola Brasileira de Psicanálise do campo freudiano (EBP), 217
- Esman, Aaron H., 196
- Espace analytique, L', 611, 612, 1010, 1084
- Espasa, Palacio, 394
- Espinosa, O., 315
- Esquema Conceptual Referencial y Operativo* (ECRO), 1285
- Esquirol, Jean-Étienne, 1178, 1272, 1421, 1528
- Esquisses Psychanalytiques*, 1084
- Essais de psychanalyse* (Freud), 1696
- Essays* (Andreas-Salomé), 83
- Essays on Applied Psychoanalysis* (Jones), 893
- Essential depression, **523–524**, 1409
- Estates General of Psychoanalysis, 328
- Esterson, Arnold, 699
- Estrangement, **524–525**
- Estudios de psicología dinámica* (Matte-Blanco), 284
- Étapes majeures de l'enfance, Les* (Dolto-Marette), 1852
- Etchegoyen, Horacio  
 Argentinian psychoanalysis and, 118, 119  
 Chilean psychoanalysis and, 285  
 International Psychoanalytical Association and, 567, 859  
 on primary identification, 1314
- Eternity's Sunrise* (Blackett-Milner), 190
- Ethics, **525–526**
- Ey on, 540  
 Kantianism and, 905  
 Lainé on, 937
- Ethics of Psychoanalysis, The* (Lacan), 894–895, 1743
- Ethnology  
 Devereux on, 154  
 on parenthood, 1237  
 on primitive horde, 1320  
 totemism and, 1768  
 on transgression, 1791
- Ethnopsychanalysis, **526–527**  
 Devereux on, 154, 409–410
- ethology and, 528  
 on individual, 810
- Ethology, 115, 307, **527–528**, 837
- Être psychanalyste* (Favez), 561
- “Étude des fantasmes chez l'enfant” (Diatkine), 411
- “Étude psychosomatique de dix-huit cas de recto-colite hémorragique” (M'Uzan), 1813
- Études*, 156
- Études de psychologie médicale* (Delay), 383
- Études Freudiennes*, 178, **528–529**, 611, 613, 807
- Études poétiques*, 1696
- Études psychiatriques* (Ey), 22
- Eucharist, alcoholism and, 41
- Eumenides* (Aeschylus), 574
- Euphemism, 4
- European Federation for Psychoanalytic Psychotherapy (EPPP), 1412
- European Psychoanalytical Federation (EPF), **529–530**

Volume 1, pp. 1–662; Volume 2, pp. 663–1344; Volume 3, pp. 1345–1892

- Congrès des psychanalystes de langue française des pays romans and, 331
- Federación psicoanalítica de América latina and, 567
- Fédida and, 569
- Kestemberg-Hassin and, 911
- Leeuw and, 958
- Polish psychoanalysis and, 1292
- Romanian psychoanalysis and, 1512
- Saussure, Raymond de and, 529, 1536
- Société psychanalytique de Paris and, 1626, 1630
- Wiener psychoanalytische Vereinigung and, 1858
- European School of Psychoanalysis—Spain, 1638
- Evang, Karl, 1156
- Evenly-suspended attention, **530–533**, 655, 1299, 1368, 1384
- “Evidential Dream, An” (Freud), 746, 1074
- Evil, envy and, 508
- Évolution psychiatrique, L*, **532**, 539, 608
- Held and, 731
- Hesnard and, 532, 742, 933
- Lacan and, 37, 532
- Laforge and, 532, 933
- Minkowski and, 1057
- Parcheminey and, 1236
- Pichon and, 1283
- Revue française de psychanalyse* and, 1497
- Schiff and, 1537
- Société psychanalytique de Paris and, 532, 539, 1623
- Evolutionary theory, 736  
See also Darwinism; Lamarckianism; Phylogenesis
- Ewer, H. H., 429
- Examination dreams, **533**, 1811
- “Examination of the Earliest Pre-genital Stage of Libido Development” (Abraham), 6
- “Examples of the Active Technique” (Kovács-Prosznitz), 923
- Excitation, **533–535**  
anal eroticism and, 514  
anxiety and, 99  
binding/unbinding and, 179  
claustrophobia and, 306  
conscious processes and, 333  
dipsomania and, 412  
discharge and, 417  
disorganization and, 420  
dreams and, 437  
facilitation and, 542–543  
pain and, 1219  
pleasure principle and, 534, 1290, 1753  
protective shield and, 1340, 1341  
psychosexual development and, 1406  
reciprocal paths of influence and, 1455–1456  
regression and, 1459  
sum of, 1689
- Excretory function. See Defecation
- Exhibitionism, **535**, 1021  
activity/passivity and, 17  
aggression and, 34  
alcoholism and, 41  
nakedness dreams and, 1103  
secrets and, 1560  
sexualization and, 1595  
subject of the unconscious and, 1675  
turning around and, 1807, 1808
- Existential analysis. See *Daseinanalyse*
- Existential psychology: from Analysis to Synthesis* (Caruso), 248–249
- Existential quantifier, 1595
- Existentialism, 1535, 1668
- Exner, Sigmund, 543, 1355, 1838
- Experience, 265  
“Expérience du psychanalyste chez l’enfant et chez l’adulte devant de modèle de la névrose infantile et de la névrose de transfert, L” (Lebovici), 830
- Experience of satisfaction, **535–537**, 1713
- “Experience of Tragedy, Expectations, and the Moral Order, The” (Rubinstein), 1517
- Experiences in Groups* (Bion), 50, 184, 709, 710
- Experiment in Leisure, An* (Blackett-Milner), 190
- Experimental Diagnostics of Drives* (Szondi), 1722
- Experimentelle Untersuchungen über Assoziationen Gesunder* (Jung), 320
- Exploration de l’Affectivité Subconsciente par la Méthode du Rêve-éveillé* (Desoille), 400
- Explorations in Autism* (Meltzer), 419
- Explorations in Personality* (Murray), 1087
- Explorations of Psychoanalysis* (Greenson), 703
- Expression in Philosophy* (Deleuze), 1640
- Expression of the Emotions in Man and Animals, The* (Darwin), 366
- Expressive techniques, 1395, 1398
- External/internal reality. See Internal/external reality
- Externalization-internalization, **537**  
change and, 268  
identification and, 790  
internal objects and, 849, 850  
superego and, 471
- Extreme situation, 136, 503
- Extroversion/introversion, **537–538**, 1396
- Ey, Henri, **538–540**  
on acute psychoses, 22  
on automatism, 143
- Colloque sur l’inconscient and, 314, 315, 610
- Dalbiez and, 363, 539
- Ellenberger and, 497
- Évolution psychiatrique, L* and, 532
- Lacan and, 929
- Nodet and, 1152  
on ontogenesis, 1197  
on organodynamic current, 1392  
on phenomenology, 1267  
on psychosomatics, 1409
- Sainte-anne Hospital and, 1528
- Eye-breast, 1682
- Ezriel, Henry, 601, 699, 709, 1371
- ## F
- Fabre, Nicole, 414, 1654
- Fabric of Affect in the Psychoanalytic Discourse, The* (Green), 541, 722, 1428
- Face-to-face situation, **541–542**, 1412
- Fachinelli, Elvio, 1199
- Facilitation, **542–543**, 1605, 1607
- Fackel, Die*, **543–544**, 924, 1587, 1868–1869
- Fact of Observation in Psychoanalysis, The* (Bernfeld), 169
- Faigenbaum, Dorian, 461
- Failure neurosis, **544–545**, 1401–1402
- Faim et le corps, La: une étude psychanalytique de l’anorexie mentale* (Kestemberg, Kestemberg, and Descobert), 138, 911, 912
- Faimberg, Haydée  
on intergenerational phenomena, 846  
on internal/external reality, 848  
on phantom, 1266  
on secrets, 1560
- Société psychanalytique de Paris and, 1630
- Fain, Michel  
on allergies, 47, 48  
on censoring the lover in her, 262, 1174  
on character, 270, 274  
on child analysis, 280
- Congrès des psychanalystes de langue française des pays romans and, 331  
on death instinct, 372  
French psychoanalysis and, 613

## INDEX

Volume 1, pp. 1–662; Volume 2, pp. 663–1344; Volume 3, pp. 1345–1892

- on hallucinatory wish-fulfillment, 1867  
 on interpretation, 863  
 on object, 1170  
 on psychic causality, 1354  
 on psychosomatics, 610, 1016, 1409  
 Société psychanalytique de Paris and, 1626, 1627, 1628, 1629  
 on typical dreams, 1811  
 Fairbairn, William Ronald Dodds, **545–546**  
 American Psychoanalytic Association and, 992  
 on antilibidinal ego, 96–97  
 Bleger and, 194  
 Brazilian psychoanalysis and, 217  
 on breast as good/bad object and, 220  
 Chodorow and, 577  
 definition of psychoanalysis and, 1363  
 on ego, 467  
 on false self, 546–547  
 on id, 779  
 on internal objects, 849, 850–851  
 Klein and, 697  
 on libido, 969  
 object relations theory and, 546, 1176  
 on quasi-independence/transitional stage, 1429  
 on self, 1582  
 on splitting of the ego, 1233  
 Swedish psychoanalysis and, 1699  
 Winnicott and, 1862  
*Fait de l'analyste, Le*, 124  
*Faith Is the Answer: A Pastor and a Psychiatrist Discuss Your Problems* (Blanton and Peale), 193  
 Faladé, Solange, 455, 458, 1083, 1084  
*Fall of Man, The* (Eissler), 491  
 Falret, Jean-Pierre, 1178  
 False neuroses, 1139  
 False recognition, 524  
 False self, **546–547**, 1579, 1581–1582  
 anality and, 72  
 “as if” personality and, 122  
 autistic capsule and, 138  
 drives and, 1580  
 internal objects and, 850  
 lies and, 972  
 splitting and, 1646  
 Falzeder, Ernst, 746, 747  
 Familial unconscious, 1721  
 “Famille devant Lacan, La” (Pichon), 1284  
 Family, **547–548**  
 adolescence and, 30  
 allergic object relationship and, 47  
 Deleuze/Guattari on, 98  
 failure neurosis and, 544  
 Marxism and, 1018, 1023  
 “Family Adaptation of the Child” (Ferenczi), 494  
 Family homeostasis, 1720  
 Family romance, **548–549**  
 hero myth and, 1094–1095  
 heroic self and, 740  
 mythology and, 1096  
 “Family Romances” (Freud), 555, 1494  
 Family secret, 6  
 Family therapy  
 anorexia nervosa and, 92  
 double bind and, 433–434  
 psychoanalytic, 1371–1372  
 secrets and, 1561  
 Fanon, Frantz, **549–550**, 1009, 1014  
*Fantasias Eternas* (Langer), 941  
 Fantasy, **550–553**  
 act/action and, 9, 552–553  
 action-presentations and, 12–13  
 active imagination and, 14  
 amnesia and, 65  
 anaclysis and, 69  
 anorexia nervosa and, 91  
 anxiety and, 100–101  
 body image and, 197  
 breastfeeding and, 220, 221  
 combined parent figure and, 316  
 creativity and, 351, 352  
 daydreams and, 1493–1494  
 depression and, 394, 395  
 early interactions and, 454  
 early Oedipus complex and, 1188  
 family romance, 548–549  
 historical reality and, 748  
 ideational representation and, 785  
 internal/external reality and, 1451  
 Lacan on, 552, **553–554**  
 memories and, 1041  
 mythology and, 1096, 1099  
 paranoid-schizoid position and, 1233–1234  
 passage to the act and, 18  
 perversion and, 1255–1256  
 of pregnancy, 1302–1303  
 psychic temporality and, 1360  
 psychosexual development and, 1406  
 real trauma and, 1455  
 representation and, 551, 554, 782  
 rescue fantasies, 1487–1488  
 tics and, 1756  
 time and, 1757  
 unconscious, 115, 119–120, 1312, 1817–1818  
 wish-fulfillment and, 1865  
*See also* Primal fantasies; Reverie  
 “Fantasy and the Origins of Sexuality” (Laplanche and Pontalis), 378, 1307  
 Færgeman, Poul, 391  
 Faria, Abbé. *See* Custodio de Faria, Abbé José  
 Fascination, **555–556**  
 Fascism, 1632  
 Italian psychoanalysis and, 879, 1508, 1557, 1800, 1853  
 Reich, Wilhelm on, 271, 1022–1023, 1462  
*See also* Nazi Germany  
 Fast, Irene, 576  
 Fate neurosis, 544, **556–557**  
 Father  
 abandonment and, 3  
 adolescence and, 26, 30  
 belief and, 159  
 Bonaparte on, 200  
 certainty and, 266  
 counter-Oedipus and, 348–349  
 critical theory and, 31, 32  
 erotogenic masochism and, 518  
 female sexuality and, 571, 573  
 feminist views of psychoanalysis and, 576, 577  
*Fort-da* game and, 599, 600  
 holding and, 754  
 homosexuality and, 757  
 identification and, 789  
 individual and, 810  
 Law of the Father and, 950  
 masculine protest and, 1018–1019  
 masturbation and, 1026  
*Moses and Monotheism* on, 1078  
 nostalgia for, 3  
 primary identification and, 1313  
 Real, Symbolic, and Imaginary, 1452–1453  
 religion and, 660  
 superego and, 526  
*See also* Fatherhood; Myth of origins; Oedipus complex; Parricide  
 Father complex, **557**  
*See also* Oedipus complex  
 “Father of the Family, The” (Balint-Szekely-Kovács), 149  
 Fatherhood, **558–559**  
 Faurel, Jean. *See* Delay, Jean

Volume 1, pp. 1–662; Volume 2, pp. 663–1344; Volume 3, pp. 1345–1892

- “Fausse reconnaissance (*déjà raconté*) in Psycho-Analytic Treatment” (Freud), 381
- Faust* (Goethe), 686, 1096, 1690
- Favez, Georges, **560–561**
- Anzieu and, 104
- Association psychanalytique de France and, 122, 561
- Belgian psychoanalysis and, 158
- Documents et Débats* and, 426
- Fédida and, 569
- French psychoanalytic establishment split (1964) and, 122
- Favez-Boutonier, *Psyché* and, 559, 1350
- Favez-Boutonier, Juliette, **559–560**
- Anzieu and, 104
- Association psychanalytique de France and, 122
- Belgian psychoanalysis and, 158
- Berge and, 161
- Centre psychopédagogique Claude-Bernard and, 265, 559, 609
- Clark-Williams trial and, 304
- Desoille and, 400
- Fédida and, 569
- French psychoanalytic establishment split (1953) and, 427, 560, 930, 1619
- French psychoanalytic establishment split (1964) and, 122
- Laforgue and, 934, 1625
- Pankow and, 1222
- Psyché* and, 1350
- Schlumberger and, 1541
- Société française de psychanalyse and, 427
- Favreau, Jean Alphonse, **561–562**
- CCTP and, 264, 562
- child analysis and, 562, 610
- Congrès des psychanalystes de langue française des pays romans and, 330
- Leuba and, 963
- Mâle and, 1004
- Nacht and, 561, 1102
- photograph of, I:pl.21
- Société psychanalytique de Paris and, 1630
- Fear, 364, **562–564**, 1274
- “Fear of Breakdown, The” (Winnicott), 218, 233
- Fear of success, 544
- Feces, **564**
- anal-sadistic stage and, 73–74
- coprophilia and, 346, 1616, 1756
- object *a* and, 1173
- secrets and, 1560
- subject’s castration and, 1676
- subject’s desire and, 1678
- See also* Defecation
- Fechner, Gustav Theodor, **564–565**
- Breuer and, 224
- on constancy principle, 1322
- Ellenberger on, 497
- German romanticism and, 673
- Jokes and their Relation to the Unconscious* and, 891
- on pleasure principle, 1290
- on psychic apparatus, 1352
- on psychic energy, 1355
- psychology and psychoanalysis and, 1397
- on repetition, 1472
- on stability, 174, 371, 417, 449
- Féder, Luis, 1051, 1052
- Federación psicoanalítica de América latina (FePAL), **565–567**, 666, 1051, 1447
- See also* Coordinating Committee for Latin American Psychoanalytic Organizations
- Federn, Ernst, 172, 495, 1165
- Federn, Paul, **567–569**
- Aichhorn and, 36
- allergic object relationship and, 47
- on alteration of the ego, 469
- on altruism, 54
- Argentinian psychoanalysis and, 117
- Bibring and, 176
- Burrow and, 238
- Czech psychoanalysis and, 361
- on depersonalization, 393
- on ego boundaries, 474, 475
- on ego feeling, 474, 477–478
- ego psychology and, 466, 475, 476, 477, 487–488, 568
- on ego states, 488–489
- Fenichel and, 579
- Finnish psychoanalysis and, 584
- Hilferding-Hönigsberg and, 746
- Hollós and, 756
- Isakower and, 874
- Italian psychoanalysis and, 878
- Japanese psychoanalysis and, 887, 888, 921
- Jelliffe and, 889
- Lehrinstitut der Wiener psychoanalytischen Vereinigung, 959
- Lehrinstitut der Wiener psychoanalytischen Vereinigung and, 959
- on libido, 969
- Lorand and, 991
- Marxism and, 1017
- Meng and, 568, 1044
- on narcissism, 97, 1111
- Nunberg and, 1165
- Rivista di psicoanalisi* and, 1508
- Schilder and, 1538
- on schizophrenia, 487, 568, 1540
- Swedish psychoanalysis, 1698
- Urbantschitsch and, 1828
- Vienna Ambulatorium and, 959
- Weiss and, 1853, 1854
- Wiener psychoanalytische Vereinigung and, 1857
- Winternitz-Freud, Rosi and, 635
- Zeitschrift für psychoanalytische Pädagogik* and, 568, 1044, 1886
- Fédida, Pierre, **569–570**
- Favez-Boutonier and, 560, 569
- Groddeck and, 607
- on intergenerational phenomena, 845
- Société psychanalytique de Paris and, 1628
- Feigenbaum, A., 876
- Feigenbaum, Dorothy, 1377
- Feitelberg, Sergei, 939
- Feldmann, H., 91
- Feldmann, Sándor, 765, 766
- Felszeghy, Béla, 765
- Feltzman, Osip, 1518
- Female Eunuch, The* (Greer), 576
- Female sexuality, **570–572**, 1635–1636, 1753
- amphimixia and, 66
- aphanisis and, 105
- Bonaparte on, 200
- castration complex and, 251, 252, 253, 254
- as dark continent, 365, 1175
- Dolto-Marette on, 428
- feminist views of psychoanalysis and, 576–577
- Granoff on, 692
- hysteria and, 773
- Jones on, 697
- jouissance and, 1596
- masculinity/femininity and, 1020
- masochism and, 572
- Nin and, 1150
- object-choice and, 1174–1175
- Oedipus complex and, 1185–1186
- orgasm and, 1209
- perversion and, 1259
- phallic mother and, 1262
- phallic stage and, 570, 1263
- phallus and, 365, 570–571, 578, 1185–1186, 1265
- pregenital organization and, 1301–1302
- Spielrein on, 1639
- See also* Femininity; Penis envy

## INDEX

Volume 1, pp. 1–662; Volume 2, pp. 663–1344; Volume 3, pp. 1345–1892

- Female Sexuality* (Bonaparte), 200  
 “Female Sexuality” (Freud), 254, 516, 641, 1019  
 Feminine masochism, 572–573, 576, 1021, 1022, 1258  
*Feminine Mystique, The* (Friedan), 576  
*Feminine Psychology* (Horney-Danielson), 759  
 Femininity, 573–575  
 Andreas-Salomé on, 84  
 castration complex and, 252, 254  
 Deutsch-Rosenbach on, 1400–1401  
 as hollow space, 573, 574, 575  
 Horney on, 59  
 Lampl-de Groot on, 938  
*New Introductory Lectures on Psychoanalysis* on, 1145  
 object-choice and, 1174–1175  
 pregnancy fantasy and, 1302–1303  
 “Psychogenesis of a Case of Homosexuality in a Woman, The” and, 1389  
 Rascovsky on, 1447  
 rejection of, 113, 574, 575–576, 773, 1018, 1738  
 sexuation and, 1596  
 taboo and, 1724  
 See also Female sexuality; Masculinity/femininity  
 “Femininity as a Masquerade” (Riviere-Hodgson Verrall), 1507  
 Feminism. See Feminist views of psychoanalysis  
 Feminist views of psychoanalysis, 576–578  
 Allendy-Nel-Dumouchel and, 45  
 boundary violations and, 209  
 cinema and, 294, 295, 296  
*Confrontation* and, 612  
 Deutsch-Rosenbach and, 1401  
 female sexuality and, 571  
 Horney-Danielson, 759  
 Leclair and, 957  
 literature and, 987  
 mother goddess and, 1080  
 phallic mother and, 1262  
 Pichon and, 1283  
 Fenichel, Hanna, 1660  
 Fenichel, Otto, 578–579  
 on addiction, 23, 233  
 on *American Imago*, 60  
 on anxiety neurosis, 1137  
 Argentinian psychoanalysis and, 117  
 on asthma, 125  
 Berliner Psychoanalytisches Institut and, 166  
 Bernfeld and, 169, 579  
 Bibring and, 176  
 Bibring-Lehner and, 176  
 on boredom, 203  
 Bornstein and, 205  
 on character, 270  
 on claustrophobia, 306  
 Czech psychoanalysis and, 360, 361  
 on dipsomania, 413  
 Dosuzkov and, 432, 433  
 on early Oedipus complex, 1188  
 on evenly-suspended attention, 531  
 Garma and, 117  
 Greenson and, 703  
 Heimann and, 730  
 on indications/contraindications for psychoanalysis, 809  
 Jacobson and, 883  
 Jekels and, 888  
 Kemper, Werner Walther and, 910  
 Koch and, 214  
 Lehrinstitut der Wiener psychoanalytischen Vereinigung and, 959  
 on narcissism of minor differences, 1109  
 Nazi Germany and, 675–676, 1045  
 on neurotic defenses, 1142  
 Norwegian psychoanalysis and, 1157  
 on oral dependence, 392  
 on politics, 1293  
*Psychoanalytic Theory of Neurosis, The*, 270, 579, 1383  
 Radó and, 1441  
 Reich, Annie and, 1461  
 San Francisco Psychoanalytic Society and Institute and, 1529  
 Schultz-Hencke and, 1547  
 Second World War and, 1558  
 on silence, 1610  
 on stages, 1652  
 on stammering, 1653  
 Swedish psychoanalysis and, 1698  
 on tics, 1756  
 on transference relationship, 1789  
 U.S. psychoanalysis and, 992, 1824  
 Wiener psychoanalytische Vereinigung and, 1857  
 FePAL. See Federación psicoanalítica de América latina  
 Fer, introjection and, 7, 328, 581, 869, 870–871, 1105, 1336  
 Féré, Charles, on anxiety neurosis, 1136  
 Ferenczi, Sándor, 579–582, 638  
 Abraham, Karl and, 6  
 on active technique, 8, 15–16, 581, 607, 1729  
 on alcoholism, 41  
 on altruism, 97  
 American Academy of Psychoanalysis and, 59  
 on amphimixia, 66  
 on analyzability, 81  
 Andreas-Salomé and, 83  
 on anticipatory ideas, 95–96  
 on anxiety neurosis, 1137  
 on archaic mother, 113  
 Australian psychoanalysis and, 131  
 on autoplasmic behavior, 144  
 Balint and, 148, 149, 328, 581  
 Balint-Szekely-Kovács and, 149  
 Benedek and, 159  
 Berggasse 19, Wien IX and, 162  
*Beyond the Pleasure Principle* and, 174  
 Bigras and, 178  
 on boredom, 203  
 Bose and, 808  
 Brazilian psychoanalysis and, 217  
 British Psycho-Analytical Society and, 228  
 Burrow and, 237  
 on castration complex, 254  
 on change, 268  
 on character, 273  
 on child analysis, 279  
 on choice of neurosis, 288  
 on criminology, 354  
 on cryptomnesia, 356  
 death of, 764  
 on deferred action, 380  
 definition of psychoanalysis and, 1363  
 direct analysis and, 414  
 on dreams, 440  
 on drives, 447  
 Dubal and, 450  
 on early Oedipus complex, 1188  
 Eder and, 460, 696  
 on ego, 465  
 Eitingon and, 493  
 on elasticity, 494, 581  
 on empathy, 59, 494, 502  
 on erotogenic zones, 519  
 French psychoanalysis and, 608  
 Freud-Jung split and, 1260  
 Freud U.S. visit and, I:pl.16, 60, 207, 303, 580, 587, 1424  
 Freud’s analysis of, 423, 1781, 1781–1782  
 Fromm-Reichmann and, 652

Volume 1, pp. 1–662; Volume 2, pp. 663–1344; Volume 3, pp. 1345–1892

- Granoff and, 692  
 Groddeck and, 706  
 Gross and, 708  
 on hallucinatory, 722  
 on hallucinatory wish-fulfillment, 1866–1867  
 Hermann and, 737  
 Hesnard and, 741  
 Hoffman and, 157  
 Hogarth Press and, 753  
 Hollós and, 756  
 on homosexuality, 757  
 Hungarian psychoanalysis and, 765, 766  
 Hungarian School and, 763, 764  
 on identification, 787, 789  
 on identification fantasies, 791  
 on intergenerational phenomena, 846  
 on internal objects, 849  
 International Psychoanalytical Association and, 639, 854  
*Internationale Zeitschrift für Psychoanalyse* and, 860, 1445  
 Internationaler Psychoanalytischer Verlag and, 861  
 on introjection, 7, 328, 581, 869, 870–871, 1105, 1336  
 Jones and, 580, 651, 892  
 Klein and, 59, 580, 914  
 on knowledge instinct, 918  
 Kovács-Prosznitz and, 923  
 on libido, 969  
 on lies, 971  
 on lifting of amnesia, 977  
 “Lines of Advance in Psycho-Analytic Therapy” and, 979  
 “Little Arpád” case and, 279, 987–988, 1768  
 “Little Hans” case and, 914  
 Lorand and, 991  
 Mahler-Schönberger and, 1001  
 on Medusa’s head, 556  
 on mutual analysis, 581, 1090  
 Nacht and, 328, 1103  
 on nakedness dreams, 1103  
 on narcissism, 1106  
 on negative hallucination, 1124–1125  
 on negative transference, 1128  
 negative transference and, 77  
 on neutrality, 1144  
 on object, 1169  
 on Oedipus complex, 1322  
 on omnipotence of thoughts, 1189  
 on orgasm, 1210  
 on otherness, 1774  
 Palos and, 209, 747  
 on paranoia, 1229  
 on paranormal phenomena, 640, 1181  
 on partial drives, 1241  
 on passion, 1244  
 on phallic mother, 1261  
 photographs of, I:pl.16,22, III:pl.9  
 on phylogenesis, 1278, 1738–1739  
*Phylogenetic Fantasy*, A and, 1279  
 on pleasure in thinking, 1289  
 on prehistory, 1303  
 on primary love, 1315  
 on primary narcissism, 1315  
 on *Psychanalyse des névroses et des psychoses*, La, 1361  
 on psychic causality, 1354  
 on psychoanalyst role, 160, 268  
 psychoanalytic filiations and, 1373  
*Psychotherapia* and, 1411  
 psychotherapy and, 1412  
 Radó and, 579, 1441  
 on real trauma, 1455  
 on regression, 160, 581, 1739  
 on relaxation principle/neo-catharsis, 1464–1465  
 on repetitive dreams, 1476  
 Róheim and, 580, 1509  
 on Schreber case, 1546  
 Secret Committee and, 1561, 1562  
 on *Secrets of a Soul*, The, 1563  
 on seduction scenes, 1566  
 on seduction theory, 735  
 on silence, 1610  
 Sokolnicka-Kutner and, 1633  
 Spanish psychoanalysis and, 1637  
 Spitz and, 1641  
 splits in psychoanalysis and, 1643  
 on splitting of the ego, 1647  
 on *Studies on Hysteria*, 1671  
 Szondi and, 1722  
 on tact, 1725–1726, 1729  
 on telepathy, 1735  
 on tenderness, 1736  
 on termination of treatment, 1737, 1738  
 Thompson and, 1745  
 on tics, 1756  
 Torok and, 1765  
*Totem and Taboo* and, 1766  
 on totemism, 1768  
 on training analysis, 1769  
 on transference, 407, 422, 1777  
 transference depression and, 1781–1782  
 on transference relationship, 1787  
 on trauma, 328–329, 581  
 Urbantschitsch and, 1828  
 on “vagina dentata” fantasy, 1831  
 on war neuroses, 1848  
 Wiener psychoanalytische Vereinigung and, 1857  
*Zeitschrift für psychoanalytische Pädagogik* and, 1886  
 Ferradini, Franco, 880  
 Ferrari, Pierre, 896  
 Ferrari Hardoy, Guillermo, 117  
 Ferreira, Antonio J., 433  
 Ferreira, Pedro, 215  
 Ferri, Enrico, 353  
 Ferro, Antonino, 1297, 1733, 1784  
 Fetishism, 582–583  
 addiction and, 23  
 castration complex and, 253  
 cinema and, 295, 296  
 consciousness and, 334  
 defenses and, 375  
 exhibitionism and, 535  
 Glover, James on, 686  
 Greenacre on, 702  
 idealization and, 783  
 mnemonic symbols and, 1062  
 perversion and, 1258  
 phallic mother and, 1261  
 repression and, 1485  
 screen memories and, 1555  
 sense of smell and, 1616  
 splitting and, 1646, 1647  
 transitional phenomena and, 1794  
 “Fetishism” (Freud), 582  
*Almanach der Psychoanalyse* and, 50  
 on disavowal, 253, 416  
 “Metapsychological Supplement to the Theory of Dreams, A” and, 1048  
 on perversion, 641, 1258  
 on phallic mother, 1263  
 on psychic causality, 1354  
 on psychoses, 1404  
 on scotomization, 1554  
 on splitting of the ego, 1647  
 “Fetishism and Object Choice in Early Childhood” (Wulff), 877  
 Feuchtersleben, Ernst von, 1403, 1414  
 Feuerbach, Ludwig, 53, 1511  
 Fiasché, Angel, 1700  
 Fiasché, Dora, 1700  
 Fichte, Johann Gottlieb, 401

## INDEX

Volume 1, pp. 1–662; Volume 2, pp. 663–1344; Volume 3, pp. 1345–1892

- Fichti, Paula, 1603  
 Fichtner, Gerhard, 1670  
 Ficino, Marsilio, 1243  
 Fiction. *See* Literature  
 Field, Joanna. *See* Blackett-Milner, Marion  
 Field, Tiffany, 1304  
 Fight/flight, 151, 709  
*Figures de la psychanalyse*, 1084  
*Filigrane*, 245, 1247  
 Filipino psychoanalysis, **1268–1269**  
 Film. *See* Cinema  
*Film, The: A Psychological Study* (Münsterberg), 295  
 Fine, Alain, 348, 1629, 1631  
 Fink, Eugen, 1271  
 Fink, Siegfried, 130  
 Finland. *See* Finnish psychoanalysis  
 Finnish psychoanalysis, **583–585**  
 Finnish Psychoanalytic Society. *See* Suomen Psykoanalyytinen Yhdisytys  
 Finzi, Roberto, 1437  
 Fire, 1367–1368  
 Firestone, Shulamith, 576  
 First World War, **585–587**, 639  
 American Psychoanalytic Association and, 61  
 British psychoanalysis and, 696  
 French psychoanalysis and, 607, 1361  
 Freud, Ernst and, 586, 622  
 Freud, Martin and, 585, 586, 626  
 Freud, Oliver and, 631  
 German psychoanalysis and, 674–675  
 International Psychoanalytical Association and, 854  
 Internationaler Psychoanalytischer Verlag and, 861  
 psychoanalytic treatment and, 1729  
 racism/anti-Semitism and, 1438  
 war neuroses and, 1848  
 Wiener psychoanalytische Vereinigung and, 1857  
*First Year of Life, The* (Spitz & Cobliner), 70, 1641  
 Fischelová, V., 361  
 Fischer, Kuno, 891  
 Fisher, Charles, 242, 897  
 Fisk, Norman, 1799  
*Five Lectures on Psycho-Analysis* (Freud), 303, **587–588**, 868, 900–901, 1119, 1164, 1822–1823, 1877  
*See also* *Introductory Lectures on Psychoanalysis*  
 Fixation, **588–589**  
 cathexis and, 260  
 character and, 270  
 choice of neurosis and, 288  
 constitution and, 335  
 ego states and, 489  
 erotogenic zones and, 518  
 internal objects and, 850  
 libido and, 968  
 narcissism and, 1105  
 obsessional neurosis and, 1179  
 oral stage and, 1205  
 primal repression and, 1309, 1485  
 regression and, 588, 1460  
 stages and, 1652  
 stammering and, 1653  
 “Fixations homosexuelles chez les femmes névrosées, Les” (Saussure), 1536  
 Flagey, Danièle, 157  
 Flaubert, Gustave, 85, 1535  
 Flechsig, Paul, 1524, 1537, 1545  
 Fleischl von Marxow, Ernst, 308, 637, 1838  
 Flescher, Joachim, 879  
 Flexner report, 61, 855  
 Fliess, Robert, 233, 348, 1610  
 Fliess, Wilhelm, **589–590**  
 on bisexuality, 186  
 Deuticke and, 403  
 Eckstein and, 454, 1671  
 “Elisabeth von R.” case and, 496  
 Freud plagiarism accusation, 543, 667, 924, 1704, 1853  
 Freud’s autobiography and, 139, 140  
 Freud’s cryptomnesia and, 356–357  
 Freud’s friendship with, 168, 425, 628, 637–638, 667, 1010, 1190, 1643  
 “Irma’s injection” dream and, 873  
 latency period and, 945  
 libidinal stages and, 966  
 splits in psychoanalysis and, 1643  
 transference of creativity and, 1787–1788  
*See also* Fliess correspondence  
 Fliess correspondence, 158, 689  
 on addiction, 23  
 on alcoholism, 41  
 on anal eroticism, 514  
 on anticathexis, 94  
 on anxiety, 99  
 on applied psychoanalysis, 107  
 on autoeroticism, 141  
 on bisexuality, 1752  
 on “Cäcilie M.” case, 239, 240  
 on cathectic energy, 259  
 on censorship, 262  
 on compulsion, 322  
 on coprophilia, 346  
 on defenses, 374  
 on deferred action, 378  
 on definition of psychoanalysis, 1363, 1364  
 on dipsomania, 412  
 on displacement, 421  
 on “Dora” case, 605  
 on dreams, 436  
 on dreams of convenience, 344  
 on erotogenicity, 520  
 on fantasy, 550  
 on feces, 564  
 on Freud, Emanuel, 633  
 on Freud, Jakob Kolloman, 625  
 on Freud, Joham, 632  
 on Freud, Julius, 633  
 on Freud, Martin, 625–626  
 Freud’s self-analysis and, 589–590, 628, 1568  
 on gain, 664  
 on Gattel, 667  
 German psychoanalysis and, 674  
 on heredity of acquired characters, 736  
 on humor, 762  
 on identification, 787, 790  
 on incest, 804  
 on “Katharina” case, 909  
 on language, 917  
 on Law of the Father, 950  
 on letter, 961  
 on libido, 967–968  
 on lifting of amnesia, 977  
 on masculinity/femininity, 1019  
 on melancholia, 21  
 on memories, 1041  
 on metapsychology, 1049  
 on mnemonic traces, 1063  
 on myth of origins, 1092  
 on nakedness dreams, 1103  
 on narcissistic neuroses, 1113  
 on neurasthenia, 1135  
 on neuroses, 287, 288, 735  
 on neurotica, 1142  
 on Oedipus complex, 1183, 1188  
 on oral eroticism, 515  
 on organic repression, 1207  
 on orgasm, 1209  
 on pain, 1281  
 on pairs of opposites, 1220  
 on parapraxes, 1235  
 on partial drives, 1240

Volume 1, pp. 1–662; Volume 2, pp. 663–1344; Volume 3, pp. 1345–1892

- on preconscious, 1300  
 on primal scene, 1310  
 on primitive, 1319  
 on projection, 1335  
 on proton-pseudos, 1342  
 on psychic causality, 1353  
 on psychoanalytic nosography, 1375  
 publication of, 611, 642  
 Schur and, 628  
 on seduction theory, 1563–1564, 1592, 1754–1755  
 on sense of smell, 1616  
 on sexuality, 1593  
 on Shakespeare, 1597  
 on slips of the tongue, 1615  
 on specific actions, 1638  
 on *Studies on Hysteria*, 1670  
 on supervised analysis, 1692  
 on symptom-formation, 1716  
 on translation, 1797  
 on truth, 1805  
 on unconscious, 1818–1819  
 on undoing, 1821–1822  
 on wish-fulfillment, 1864  
 on wishes, 1867  
 on working over, 1878  
*See also* “Project for a Scientific Psychology, A”  
 Flight into illness, **590**, 664  
 Flooding-dreams, 1559  
 Flora, Francesco, 1508  
 Florenzano, Ramón, 285  
 Flores, Sara, 1254  
 Flournoy, Henri, **590–591**  
*Archives de psychologie*, Les and, 302  
 Baudouin and, 154  
 Sechehaye and, 1556  
 Société psychanalytique de Paris founding and, 591, 608  
 Swiss psychoanalysis and, 1620, 1700, 1703  
 Flournoy, Olivier, 331, 1628, 1701  
 Flournoy, Théodore, **591–592**  
*Archives de psychologie*, Les and, 115–116  
 Claparède and, 301  
 on cryptomnesia, 356, 591–592  
 Jung and, 1399  
 Piaget and, 1282  
 Silberer and, 1608  
 on *Studies on Hysteria*, 1671  
 Swiss psychoanalysis and, 1700  
*Flower Dolls: Essays in Child Psychotherapy* (Dolto-Marette), **592–593**  
 Flügel, John Carl, **593–594**, 697, 873  
 Fluss, Gisela, **594–595**, 1609  
 Flying dreams, 1811  
*Foco*, 217  
*Foi qui guérit, La* (Charcot), 170  
 Foissin, Monique, 934, 1154  
 Folch-Mateu, P., 331  
 Folch Mateu, Pere, 1296  
*Folie chez l'enfant, La* (Moreau de Tours), 827  
 Follin, S., 315  
 Fonagy, Ivan, 982, 1153, 1653  
 Fonagy, Peter, 822, 888, 1030, 1732  
 Fontaine, Roberto, 1014  
 Forced choice (*vel*), 44  
*Forces of Destiny, The* (Bollas), 1580  
 Forclusion, 252  
 Fordham, Michael, 80, 1728  
 Foreclosure, **595–596**  
 disavowal and, 417  
 infantile psychosis and, 826  
 negation and, 1121–1122  
 neuroses and, 1139  
 perceptual identity and, 1249  
 Pichon on, 1284  
 psychoses and, 1404  
 psychotic defenses and, 1413  
 Real and, 1453  
 repudiation and, 1487  
 scotomization and, 1554  
 splitting and, 1646  
 structural theories and, 1667  
 work of the negative and, 1129  
 Forel, August, 194, 231, 235, 1052, 1685, 1702  
 Forgetting, 325, 382, **596–597**, 1402–1403, 1482  
*See also* Amnesia; Parapraxes; Slips of the tongue  
 Forman, E., 1851  
*Formation de l'esprit scientifique, La* (Bachelard), 145  
 Formations of the unconscious, **597–598**  
 interpretation and, 862  
 metaphor and, 1047  
 overdetermination and, 1217  
 wish-fulfillment and, 1864  
*See also* Dreams; Parapraxes; Slips of the tongue  
*Formations of the Unconscious, The* (Lacan), 597, 692–693, 1172  
 Former Yugoslavian psychoanalysis, **1884–1885**  
 “Forms and Transformations of Narcissism” (Kohut), 784, 920, 1423  
 Formula of the signifier, 1031  
 Formulas of sexualization. *See* Sexualization, formulas of  
 “Formulations on the Two Principles of Mental Functioning” (Freud), 9  
 on attention, 127  
 on binding/unbinding, 179  
 on choice of neurosis, 288  
 on condemning judgments, 901  
 on conflict, 326  
 on constancy principle, 1151  
 on developmental processes, 1330  
 on ego, 462, 1048  
 on experience of satisfaction, 536  
 on fantasy, 551  
 grids and, 704  
 on hallucinatory wish-fulfillment, 1866  
 on internal/external reality, 848  
 on logic, 989  
 on maternal care, 1029  
 on mythology, 1095  
 on pleasure principle, 1291, 1325, 1807  
 on primary narcissism, 1110  
 on purified-pleasure-ego, 1423  
 on reality principle, 1450  
 on thought, 1746, 1747  
 on work, 1876  
 Fornari, Franco, 331, **598–599**, 880, 881  
*Forschertrieb*. *See* Knowledge instinct  
 Forsyth, David, 696  
*Fort-da* game  
 capacity to be alone and, 246  
 childhood and, 280, 283, 599–600  
 death instinct and, 371  
 infant observation and, 817  
 language and, 1874  
 metaphor and, 1048  
 object *a* and, 1173  
 object loss and, 994  
 symbolic and, 600, 927  
 symptoms and, 1714  
 thought-thinking apparatus and, 1750  
 Forum (Martinique), 1014  
*Forum der Psychoanalyse*, 679  
 Forums de champ lacanian, 456  
 Forzano, Giovacchino, 879  
 Foucault, Michel, 459, 613, 1380, 1668, 1699  
 Foulkes, Siegmund Heinrich, **600–601**  
 Burrow and, 238  
 on group analysis, 709, 713, 1371



## INDEX

Volume 1, pp. 1–662; Volume 2, pp. 663–1344; Volume 3, pp. 1345–1892

- Italian psychoanalysis and, 880  
 Landauer and, 940  
 Main and, 1003  
 Tavistock Clinic and, 1728  
*Foundations of the Nineteenth Century* (Chamberlain), 1437  
 Fouque, Antoinette, 328, 612, 957  
 Fouquet, Pierre, 40, 413  
 Four discourses, **601–602**, 931, 1031  
*Four Fundamental Concepts of Psychoanalysis, The* (Lacan), 930, 969–970, 1453–1454, 1583, 1674  
*Four Servants* (Bion), 184  
 Fourier, Charles, 1437  
 Fourth analysis, **602–604**, 611, 1430  
 Fourth Group. *See* Quatrième Groupe (Fourth Group)  
 “Fragment of an Analysis of a Case of Hysteria”. *See* “Dora” case  
 Fragmentation, **605–606**  
   anxiety and, 100  
   disintegration anxieties and, 418, 605  
   infant observation and, 816  
   paranoid-schizoid position, 1233  
 Fraiberg, Selma, 139, 821  
 Fraisse, Paul, 89, 90  
 Frame of psychoanalytic treatment, **606–607**, 1405, 1732  
 France. *See* French psychoanalysis  
*France juive, La* (Drumont), 1437  
 Franco da Rocha, Francisco, **614–615**, 1012  
 François, Frédéric, 1153  
 Frank, Jan, 361  
 Frankfurter Psychoanalytisches Institut, 1602  
 “Frankie” case, 205  
 Frankl, Viktor, **615**  
 Franz, Marie Louise von, 80, 903  
 Fraser, Donald, 130  
*Frayages*, 245, 1247  
 Frazer, James George, 85, 339, 1000, 1367, 1768  
 Frederick, Charles, 1044  
 Free association, **615–617**  
   active imagination and, 14  
   active technique and, 15  
   anticipatory ideas and, 95–96  
   binding/unbinding and, 180  
   child analysis and, 1732  
   dreams and, 438  
   Dubal on, 449  
   “emmy von N.” case and, 616, 1384  
   fundamental rule and, 615, 655, 1180  
   Jones on, 207  
   obsessional neurosis and, 1180  
   relaxation principle/neo-catharsis and, 1465  
   self-state dreams and, 1579  
 Free energy/bound energy, 260, 333, **617–618**, 1355–1356, 1878  
   *See also* Psychic energy  
 Free-floating attention. *See* Evenly-suspended attention  
 Freiberg, Selma, 1382  
 Freire de Garbarino, Mercedes, 1829  
 French, Thomas M., 47, 124, 278  
 French Lacanian organizations, 612, **1083–1084**, 1630, 1631, 1645  
   *See also* Lacan, Jacques-Marie Émile  
   *See also specific organizations*  
 French psychoanalysis, **607–614**  
   Centre psychopédagogique Claude-Bernard and, 265  
   Congrès des psychanalystes de langue française des pays romans and, 329, 330  
   *Disque vert, Le* and, 423, 607  
   Ey and, 539  
   feminist views of psychoanalysis and, 577–578  
   Granoff and, 692  
   group analysis and, 710  
   Jankélévitch, 886–887  
   Lacan on, 37, 38  
   *See also* French Lacanian organizations; French psychoanalytic establishment split (1953); French psychoanalytic establishment split (1964); Société française de psychanalyse; Société psychanalytique de Paris  
   French Psychoanalytic Association. *See* Association psychanalytique de France  
   French psychoanalytic establishment split (1953), 427, 609, 929–930, 1644–1645  
   Berge and, 161  
   Bouvet and, 210  
   *Confrontation* and, 327  
   Congrès des psychanalystes de langue française des pays romans and, 330  
   Favez and, 561  
   Favez-Boutonier and, 427, 560  
   Granoff and, 692  
   Hesnard and, 743  
   Laforgue and, 934  
   Laurent-Lucas-Championnière-Maugé and, 949  
   Lebovici and, 954–955  
   Leclaire and, 692, 957  
   Mâle and, 1004  
   Mannoni and, 1009  
   Mannoni-Van der Spoel and, 1010  
   Marty and, 1016  
   Nacht and, 560, 609, 929, 1102, 1644  
   Perrier and, 692, 1251  
   Raimbault, Émile and, 1442  
   Reverchon-Jouve and, 1493  
   *Revue française de psychanalyse* and, 1499  
 French psychoanalytic establishment split (1964), 455, 457, 609, 1619, 1645  
   Anzieu and, 104, 122  
   Aulagnier-Spairani and, 129  
   Belgian psychoanalysis and, 158  
   Berge and, 162  
   *Confrontation* and, 327  
   Dolto-Marette and, 427  
   Enriquez-Joly and, 506  
   Favez and, 561  
   Hesnard and, 743  
   *Inconscient, L’* and, 806  
   Lacan/Dolto excommunication, 162, 327, 427, 455, 611, 692, 930  
   Leclaire and, 611, 957  
   Perrier and, 611, 957, 1251, 1645  
   Smirnoff and, 122, 1617  
 French Psychoanalytic Society. *See* Société française de psychanalyse  
*Freud: Living and Dying* (Schur), **627–628**, 1548  
*Freud: Master and Friend* (Sachs), 1523, 1561  
*Freud* (Mannoni), 1009  
 Freud, Alexander Gotthold Efraim, **635–636**  
 Freud, Anna, **618–620**  
   on abandonment, 2  
   on abstinence, 8  
   on acting out, 11  
   on adaptation, 22  
   on adolescence, 27, 28  
   Aichhorn and, 36  
   on altruism, 54  
   Andreas-Salomé and, 83  
   Aubry Weiss and, 128  
   Austrian psychoanalysis and, 133  
   Bettelheim and, 172  
   on blank psychoses, 192  
   Blos and, 196  
   Bornstein and, 205  
   Bowlby and, 212  
   Burlingham and, 162, 236  
   child analysis and, 76, 279, 618–619, 697, 1386–1387, 1731–1732, 1733, 1783  
   on childhood, 281

Volume 1, pp. 1–662; Volume 2, pp. 663–1344; Volume 3, pp. 1345–1892

- on children's play, 283  
 Chilean psychoanalysis and, 284, 1033  
 cinema and, 293  
 Congrès mondial de psychiatrie and, 532, 539  
 Czech psychoanalysis and, 360  
 on defenses, 375, 377  
 definition of psychoanalysis and, 1363  
 on depression, 70–71  
 Detski Dom and, 402  
 on developmental processes, 1330  
 on ego, 466, 472–473, 476, 477, 486  
 on ego functions, 478  
 on ego psychology, 1652  
 Eissler and, 490  
 Emden and, 498  
 on encopresis, 504  
*Évolution psychiatrique, L'* and, 532  
 on externalization-internalization, 537  
 on fear, 563  
 First World War and, 585  
 Freud, Martin and, 626  
*Freud, The Secret Passion* and, 644  
 Freud and, 641  
 Freud Museum and, 629, 642  
 Freud's analysis of, 618, 640, 1021  
 Freud's Gestapo comment and, 682  
 Friedländer-Fränk and, 646  
 Geleerd and, 668  
*Gesammelte Schriften* and, 680  
*Gesammelte Werke* and, 680  
 Goethe Prize and, 687  
 Greek psychoanalysis and, 700  
 Hampstead Clinic and, 619, 697, 724  
 Hartmann and, 727, 728  
 Hellman Noach and, 733  
 Hietzing Schule and, 745  
 Hoffer and, 752–753  
 Hogarth Press and, 753  
 on homosexuality, 8  
 Hungarian School and, 766  
 on identification, 790  
 on identification with the aggressor, 54, 792–793  
*Imago* and, 803  
 Imago Publishing Company and, 802  
 on infant development, 814  
 on infantile neurosis, 821  
*International Journal of Psychoanalysis, The* and, 229, 853  
 on isolation, 876  
 Japanese psychoanalysis and, 888  
 Jones and, 893  
 on Judaism, 900  
 Katan and, 907  
 Katan-Rosenberg and, 908  
 Klein and, 915  
 Kris-Rie and, 925, 1503  
 Lampl-de Groot and, 938  
 Lebovici and, 955  
 Lehrinstitut der Wiener psychoanalytischen Vereinigung and, 959  
 Lehrman and, 960  
 on "Little Hans" case, 75–76  
 Mahler-Schönberger and, 1001  
 Main and, 1003  
 Mitscherlich and, 1060  
 Morgenstern-Kabatschnik and, 1073  
 Nazi Germany and, 725  
 on neutrality, 1144  
 New York Psychoanalytic Institute/Society and, 1148  
 on paranormal phenomena, 1181, 1735  
 on perversion, 1258  
 on phobias, 1274  
 photographs of, I:pl.23,27  
 on pregenital stage, 1186  
*Psychoanalytic Study of the Child, The* and, 492, 728, 1381  
*Psychoanalytical Treatment of Children, The*, 833, 1386–1387  
 "Rat Man" case and, 821  
 Reich, Annie and, 1461  
 Robertson and, 1509  
 Rosenfeld, Eva Marie and, 1513–1514  
 Ross and, 1516–1517  
 Sandler and, 1533  
 Schilder and, 1538  
 Sechehaye and, 1557  
 Second World War and, 1557  
 Secret Committee and, 1562  
 on self, 1567  
 Servadio and, 1586  
*Sigmund Freud: Life and Work* and, 974  
 Sigmund Freud Archives and, 1600  
 Sigmund Freud Copyrights Limited and, 1601–1602  
 Sigmund Freud Museum and, 1603  
 Sigmund Freud Society and, 136, 163  
 on silence, 1610  
 Spitz and, 528  
 on splits in psychoanalysis, 1645  
 on splitting of the object, 1649  
*Standard Edition* and, 1654–1655  
 Sterba and, 1658, 1659  
 Stone and, 1661  
 Strachey and, 1662–1663  
 on structural theories, 1666  
 Swedish psychoanalysis and, 1698  
 Swiss psychoanalysis and, 1549  
 theme of three and, 1740  
 on transference, 1783  
 on turning around, 1808  
 U.S. psychoanalysis and, 1825  
 Waelder and, 1845  
 Wiener psychoanalytische Vereinigung and, 1857  
 Winternitz-Freud, Rosi and, 635  
*Zeitschrift für psychoanalytische Pädagogik* and, 1886  
 See also Controversial Discussions; Klein-anna Freud conflict  
 Freud, Emanuel, **632–633**  
 Freud, Ernst, **621–623**, 1601  
 Eitingon and, 493  
 First World War and, 586, 622  
 Hampstead Clinic and, 724  
 Freud, Esther Adolfine, **635**  
 Freud, Jakob Kolloman, I:pl.25, **623–625**, 1268  
 Freud, Joham, 632  
 Freud, John, 1539  
 Freud, Josef, 623, **627**  
 Freud, Julius, 425, **633**  
 Freud, Lucie, 1601  
 Freud, Martin, **625–626**  
 Charcot and, 1529  
 First World War and, 585, 586, 626  
 Imago Publishing Company and, 801  
 Internationaler Psychoanalytischer Verlag and, 862  
 Sigmund Freud Copyrights Limited and, 1601  
 Freud, Oliver, **631–632**  
 Freud, Pauline, 632  
 Freud, Philipp, **633**  
 Freud, Sigmund Schlomo, **636–643**  
 Abraham and, 5, 1191  
 on abstinence, 7–8, 1786  
 on acting out, 10  
 on active technique, 15, 16, 640  
 on actual vs. defense neuroses, 19, 1138–1139  
 on addiction, 23  
 addiction and, 42  
 Adler, Alfred and, 25, 639, 1643  
 on adolescence, 28  
 on affectionate current, 56

## INDEX

Volume 1, pp. 1–662; Volume 2, pp. 663–1344; Volume 3, pp. 1345–1892

- on agency, 32–33  
 on aggression, 33–34  
 Aichhorn and, 36  
 Ajase complex and, 39  
 on alcoholism, 40–41, 42  
*Almanach der Psychoanalyse* and, 50  
 on alteration of the ego, 468  
 on altruism, 53–54  
 on ambivalence, 56, 57  
 on amentia, 58  
 on *American Imago*, 60  
 on amnesia, 63–64, 819–820, 976–977  
 on anaclysis, 68–69, 70, 1191  
 on anagogical interpretation, 71  
 on anal eroticism, 514–515  
 on anal-sadistic stage, 73, 74  
 on anality, 72  
 on analysand, 74  
 on analyzability, 81, 1787  
 Andersson on, 82  
 Andreas-Salomé and, 83  
 on animistic thought, 85–86  
 on “Anna O.” case, 88, 225  
 on annihilation anxieties, 90  
 on anthropology, 92–93  
 on anticathexes, 94  
 on anticipatory ideas, 94  
 on anxiety, 99, 100, 779  
 on anxiety dreams, 102–103  
 on anxiety neurosis, 1135–1137  
 on aphasia, 106  
 on applied psychoanalysis, 107–108  
 on archaic, 111–112, 113  
 archeological metaphor use, 111, 112, 113, 114, 336–337, 750, 1040–1041  
 Argentinian psychoanalysis and, 116  
 attacks on linking and, 983–984  
 on attention, 127, 952  
 Australian psychoanalysis and, 130  
 on autism, 136  
 on autoeroticism, 141  
 on automatism, 143  
 on autoplasmic behavior, 144  
 Bachelard and, 1367–1368  
 Baginsky, Adolf and, 146, 842  
 on basic assumption, 711  
 Baudouin and, 154  
 Belgian psychoanalysis and, 156–157  
 Berggasse 19, Wien IX and, 162–163  
 Berliner Psychoanalytisches Institut and, 165  
 Bernays-Freud, Minna and, 167–168, 621  
 Bernfeld and, 168  
 Bernheim and, 170  
 Bettelheim and, 173  
 on *Beyond the Pleasure Principle*, 173–174  
 on binding/unbinding, 179–180  
 Binswanger and, 180–181  
 biographies of, 611, 623, 627–628, 642, 644, 651, 893, 973–974, 1197, 1548, 1869  
 on biological bedrock, 182, 575, 1278  
 Bion and, 184  
 on birth, 185–186  
 on birth trauma, 124, 641  
 on bisexuality, 186–187, 1587, 1660  
 Bjerre and, 188, 189, 1697  
 Blanton and, 192–193  
 Bleuler and, 194  
 on body ego, 139  
 on body image, 197  
 Bonaparte and, 199, 200, 974  
 on boredom, 203  
 Bose and, 206  
 Bouvet and, 210  
 Brazilian psychoanalysis and, 217, 1012  
 on breast as good/bad object and, 219  
 on breastfeeding, 220–221  
 Brentano and, 222–223  
 Breton and, 223, 224, 1695  
 British Psycho-Analytical Society and, 228  
 Brücke and, 231, 637  
 Brunswick and, 232, 233  
 Burghölzli Asylum and, 236  
 Burlingham and, 236  
 Burrow and, 237–238  
 “Cäcilie M.” case and, 239–240  
 on case histories and, 250  
 on castration complex, 251–255  
 on cathartic method, 258  
 on cathectic energy, 259  
 on cathexis, 259–260  
 on censorship, 262  
 on certainty, 265–266  
 on change, 267–268  
 on character, 269–270, 272, 273  
 Charcot and, 170, 275–276, 637, 1528–1529  
 on child analysis, 1731  
 on childhood, 280  
 on children’s play, 282–283  
 on Chilean psychoanalysis, 284  
 on choice of neurosis, 287–288  
 Choisy and, 289  
 on cinema, 292–293  
 on civilization, 298–299  
 Claparède and, 302  
 on claustrophobia, 306  
 on cocaine, 307–308  
 cognitivism and, 309  
 collective psychology and, 311–312  
 on communism, 1519  
 on complementary series, 318  
 on complexes, 318–319  
 on compromise formations, 321, 1066  
 on compulsion, 322  
 on condemning judgments, 900–901  
 on condensation, 324–325  
 on conflict, 325–326  
 Congrès des psychanalystes de langue française des pays romans and, 329  
 Congrès international de l’hypnotisme expérimental et scientifique and, 332  
 on conscious processes, 332–333  
 on consciousness, 333–334  
 on constancy principle, 1322–1323  
 on constitution, 334  
 on constructions, 336–338  
 on contact, 338, 339  
 on contact-barrier, 339  
 on contradiction, 341, 342  
 on conversion, 345  
 on counter-Oedipus, 348  
 on counter-transference, 349–350  
 on creativity, 351  
 on criminology, 353  
 on cruelty, 354–355  
 on cryptomnesia, 356–357  
 on cultural transmission, 357  
 on culture, 296–297, 640, 641  
 on cure, 358  
 Czech psychoanalysis and, 360  
 Dalí and, 1696  
 on danger, 364  
 on Darwinism, 366–367  
 on daydreams, 554–555, 1493, 1817  
 on day’s residues, 367, 437, 438  
 on death, 370, 1751  
 on death instinct, 371–372, 508, 509, 523  
 death of, 344, 619, 621, 641–642, 1557, 1644  
 on decathexis, 374  
 on defense mechanisms, 376  
 on defenses, 374–375  
 on deferred action, 378, 379–380  
 on definition of psychoanalysis, 1362  
 on déjà vu, 381–382

Volume 1, pp. 1–662; Volume 2, pp. 663–1344; Volume 3, pp. 1345–1892

- Delboeuf and, 384  
 Delgado and, 385, 1253  
 on delusions, 385, 791  
 on dementia, 389  
 on dependence, 391–392  
 depersonalization and, 393  
 on depression, 394  
 on deprivation, 397, 760  
 on derivatives of the repressed, 1481, 1484  
 Desoille and, 400  
 on destrudo, 400  
 on determinism, 401–402  
 Deuticke and, 403  
 Deutsch and, 404  
 Deutsch-Rosenbach and, 405  
 on developmental disorders, 408  
 on developmental processes, 1329–1330  
 on dipsomania, 412, 413  
 on disavowal, 415–416  
 on discharge, 417  
 on disillusionment, 1750–1751  
 on disorganization, 420  
 on displacement, 421–422  
*Disque vert, Le* and, 423  
 on double, 429, 434–435  
 on doubt, 435–436  
 on dream symbolism, 437, 441–442, 1811  
 on dream work, 442  
 on dreams, 367, 436–437, 438–439, 443, 866–867, 1190  
 on dream's navel, 443, 1453  
 on dreams of convenience, 344  
 on dreams of mourning, 1083  
 on drives, 444–447  
 on dualism, 448–449  
 Dubal and, 450  
 on dynamic point of view, 451  
 on eating disorders, 91, 233  
 Eckstein and, 454–455, 667  
 Eder and, 461  
 on ego, 461–466, 475–476, 775  
 on ego functions, 478–479  
 on ego ideal, 479–480  
 on ego-instincts, 482–483  
 on ego interests, 484  
 on ego syntony, 489  
 Eitingon and, 493  
 on “Elisabeth von R.” case, 495–496  
 Ellenberger on, 497  
 Emden and, 498  
 on “Emmy von N.” case, 499–500  
 on emotions, 501  
 on encounter, 505  
 on enuresis, 507  
 on envy, 508  
 on epistemology, 1370  
 on Eros, 511–513  
 on erotogenic masochism, 517–518, 1315–1316  
 on erotogenic zones, 518–519, 1205–1206  
 on erotogenicity, 519–521  
 on erotomania, 521–522  
 on erythrophobia, 522–523  
 on estrangement, 524  
 on ethics, 525–526  
 on ethnopsychanalysis, 527  
 on evenly-suspended attention, 530–531  
 on examination dreams, 533  
 on excitation, 533  
 on exhibitionism, 535  
 on experience of satisfaction, 536  
 on externalization-internalization, 537  
 on facilitation, 542–543, 1605, 1607  
*Fackel, Die* and, 543, 924  
 on failure neurosis, 544  
 on family, 547, 547–548  
 on family romance, 548–549, 740  
 on fantasy, 550–552  
 on fascination, 555–556  
 on father, 1452  
 on father complex, 557  
 father of, I:pl.25, 623–625, 1080–1081, 1269  
 Favez-Boutonier and, 559  
 on fear, 562–563  
 on feces, 564  
 Fechner and, 564–565, 1397  
 Federn, Paul and, 568  
 on female sexuality, 570–571, 573–574, 576, 1635–1636, 1753  
 on female sexuality as dark continent, 365, 1175  
 on feminine masochism, 572  
 Ferenczi and, 580, 581, 1781–1782  
 on fetishism, 582, 1258  
 films on, 293, 642, 644–645  
 First World War and, 585–586  
 on fixation, 588  
 on flight into illness, 590, 664  
 Flournoy, Henri and, 591  
 Flournoy, Théodore and, 592  
 Fluss and, 594–595  
 on forgetting, 596–597  
 on formations of the unconscious, 597, 598  
 on *Fort-da* game, 599, 600, 994, 1048  
 fourth analysis and, 603–604  
 on frame of psychoanalytic treatment, 606  
 Frankl and, 615  
 on free association, 615–616  
 on free energy/bound energy, 617–618  
 French psychoanalysis and, 607, 608  
 Freund Töszeghy and, 174, 586, 639, 645  
 on friendship, 646–647  
 on fright, 648  
 Frink and, 648, 649  
 on frustration, 653, 654  
 on functional phenomenon, 654–655  
 on fundamental rule, 655–657  
 on fusion/defusion, 658–659  
 on gain, 664  
 Gattel and, 666–667  
 on gaze, 990  
 on gender identity, 668  
 on genital stage, 672–673  
 German romanticism and, 673–674  
 Gestapo comment, 681–682  
 on gifts, 682–683  
 Goethe and, 686–687, 984, 1838  
 Goethe Prize award, 687, 1044  
 Groddeck and, 200, 705  
 Gross and, 707, 708  
 on group analysis, 237–238  
 on groups, 237–238, 712–713  
 Guilbert and, 715, 716  
 on guilt, 716, 717  
 Halberstadt-Freud, Sophie and, 372, 719–720  
 on hallucinatory, 722  
 on hallucinatory wish-fulfillment, 1865–1866  
 hard science and, 726  
 Hartmann and, 727  
 on hatred, 728–729  
 H.D. and, 429, 430–431  
 Heller and, 732  
 on heredity of acquired characters, 736  
 on hermeneutics, 738  
 on heroic self, 739  
 Hesnard and, 741, 742  
 on heterosexuality, 743–744  
 Hirschfeld, Elfriede and, 746–747  
 on historical reality, 335, 748  
 on historical truth, 749  
 on history, 750  
 Hitschmann and, 751–752  
 Hollitscher-Freud and, 755  
 Hollós and, 756

## INDEX

Volume 1, pp. 1–662; Volume 2, pp. 663–1344; Volume 3, pp. 1345–1892

- on homosexuality, 757, 758, 1389–1391  
on humor, 762–763  
Hungarian School and, 764  
on hypercathexis, 767  
on hypnosis, 332, 769, 1685  
on hypochondria, 770–771  
on hypocritical dreams, 771–772  
on hysteria, 772–773  
on hysterical paralysis, 773–774  
on id, 776, 777–780  
on ideal ego, 481, 1191  
on idealization, 783–784  
on ideational representation, 785  
on ideational representative, 786, 841  
on identification, 56, 787–790, 790, 798, 1314, 1814  
on ideology, 796  
on illusion, 796–797  
on imaginarity, 799  
*Imago* and, 800, 802  
Imago Publishing Company and, 801–802  
on incest, 804  
on incompleteness, 805–806  
Indian psychoanalysis and, 807  
on indications/contraindications for psychoanalysis, 808–809  
on individual, 810  
on inertia principle, 1324–1325  
on infant development, 814  
on infant observation, 817  
on infantile omnipotence, 823  
on infantile sexual curiosity, 829, 1195, 1262, 1590  
on infantile sexuality, 830, 1405, 1752–1755  
on inferiority feelings, 831  
on inhibition, 832–833  
on initial interview, 835  
on innervation, 836  
on instincts, 837–838  
on instinctual impulse, 839–840  
on instinctual representative, 841  
Institut Max-Kassowitz and, 842–843  
on intellectualization, 844–845  
on intergenerational phenomena, 845  
on internal/external reality, 847–848  
on internal objects, 395, 849–850  
International Psychoanalytical Association and, 854  
*Internationale Zeitschrift für Psychoanalyse* and, 860, 1445  
Internationaler Psychoanalytischer Verlag and, 861  
on interpretation, 71, 862–863  
on introjection, 869, 871, 1642  
on isolation, 875–876  
on It, 201  
Italian psychoanalysis and, 878  
Jackson and, 539  
*Jahrbuch der Psychoanalyse* and, 884  
*Jahrbuch für psychoanalytische und psychopathologische Forschungen* and, 884  
Janet and, 886, 1397  
Jankélévitch and, 887  
Japanese psychoanalysis and, 887  
Jekels and, 888  
on jokes, 890, 891–892  
Jones and, 892, 893  
Judaism and, 425, 624, 898–900, 1269  
Jury and, 904  
Kantianism and, 905  
Kardiner and, 906  
on “Katharina” case, 26, 909  
on knowledge instinct, 917–918  
Kris and, 924  
Kris-Rie and, 925  
Lacan and, 38, 930  
Laforge and, 933  
Lampl-de Groot and, 938  
on language, 942–943, 1606  
on latency period and, 945–946  
on latent/manifest dream elements, 947, 948, 1007–1008  
law and, 949–950  
on law and psychoanalysis, 949  
on Law of the Father, 950  
on lay analysis, 855, 951, 1118, 1432–1433  
Le Bon and, 953–954  
on letter, 961  
on libidinal development, 965–967  
on libido, 967–969, 970  
on lies, 971  
on life instinct, 174–175, 297, 511–512, 513, 975  
on lifting of amnesia, 976–977  
on lifting of repression, 1486  
on linguistics, 981  
on literature, 984–985, 986  
on logic, 989–990  
on love, 671, 994–995  
on love trauma, 1656  
Maeder and, 999  
on magical thinking, 1000  
Mahler, Gustav and, 1000–1001  
on mania, 1006, 1007  
Marcinowski and, 1011  
on Marxism, 1017  
on masculinity/femininity, 577, 1019–1020, 1400  
on masochism, 1020–1022, 1315–1316  
on mastery, 1023–1024, 1025  
on masturbation, 1026–1027  
on maternal, 1027–1028  
on maternal care, 1028  
on megalomania, 1036  
on melancholia, 21, 1037–1039, 1082–1083  
on memories, 1040, 1041  
on memory, 1042–1043  
on metapsychology, 1049  
Meynert and, 1054  
*Minutes of the Vienna Psychoanalytic Society* and, 1058  
on mnemonic symbols, 1061–1062  
on mnemonic traces, 1062–1065  
on modesty, 1067  
monism/dualism and, 1070–1071  
on moral masochism, 1071–1072  
Morselli and, 1076  
on mother goddess, 1080  
mother of, 629–630  
on mourning, 3, 21, 1082, 1798  
on multidisciplinary interactions, 108  
on multilingualism, 1086  
on music, 1088  
Mussolini and, 879  
on mystic writing pad, 1158–1159, 1613, 1757, 1819  
on myth of origins, 1092–1093, 1239  
on mythology, 107, 1095–1097, 1099, 1739–1740  
on nakedness dreams, 1103  
on narcissism, 1104–1106, 1190–1191  
on narcissism of minor differences, 1109  
on narcissistic neuroses, 1113  
on narcissistic withdrawal, 1116, 1117  
Nazi Germany and, 681–682  
on need for causality, 1118–1119  
on need for punishment, 1120  
on negation, 1121, 1122–1123  
on negative hallucination, 1124, 1125  
on negative therapeutic reaction, 1125–1127, 1469–1470, 1782  
on negative transference, 1127, 1128  
*Nervous Anxiety States and their Treatment* and, 1131–1132  
on neurasthenia, 1135  
on neuro-psychooses of defense, 1138  
on neurophysiology, 212–213

Volume 1, pp. 1–662; Volume 2, pp. 663–1344; Volume 3, pp. 1345–1892

- on neuroses, 287, 735, 1138–1139
- on neurotic defenses, 1141–1142
- on neurotica, 1142–1143
- on neutrality, 1143–1144
- on nightmares, 1149–1150
- on Nirvana principle, 1151–1152
- on nuclear complex, 1163–1164
- Nunberg and, 1165
- on object, 1168–1169, 1171
- on object-choice, 1174, 1175
- on object loss, 993–994
- on obsessional neurosis, 1179–1180
- on obsessions, 1178
- on oceanic feeling, 265–266, 895, 899, 1091, 1181–1182
- on Oedipus complex, 1183–1186, 1188
- on omnipotence, 822
- on omnipotence of thoughts, 1189, 1339
- on self-consciousness, 1569, 1570
- on ontogenesis, 1196, 1197
- on optical schema, 1200–1201
- on oral eroticism, 515–516
- on oral-sadistic stage, 1203
- on orality, 1202
- on organ pleasure, 1205–1206
- on organic repression, 1206–1208
- on organization, 1208–1209
- on orgasm, 1209–1210
- Other and, 1212–1213
- on otherness, 1214, 1774
- on over-interpretation, 1217
- on overdetermination, 1216–1217
- on pain, 1219–1220, 1280
- on pairs of opposites, 1220–1221
- on paranoia, 1227–1228, 1229–1231
- on paranoid psychosis, 1232
- on paranormal phenomena, 640, 1145, 1181
- on paraphrenia, 1234, 1403
- on partial drives, 1239–1241, 1257–1258, 1332
- on passion, 1243–1244
- on patient physical position, 541, 542
- on payment for treatment, 1068–1069
- on penis envy, 1245–1246
- on perception-consciousness system, 1248–1249
- on perceptual identity, 1249
- Perrotti and, 1251
- on persecution, 1252–1253
- Peruvian psychoanalysis and, 1253
- on perversion, 1255, 1257–1258
- Pfister and, 1260
- on phallic mother, 1261, 1263
- on phallic stage, 1262–1263
- on phallus, 1264
- philosophy and, 1269, 1270
- on phobias, 1178, 1274
- on phobic neurosis, 1276
- photographs of, I:pl.16,24–27, III:pl.9
- on phylogenesis, 1277
- on pictogram, 1285
- on pleasure, 894
- on pleasure ego/reality ego, 1288
- on pleasure in thinking, 1289
- on pleasure principle, 174, 1290–1291, 1325–1326
- on politics, 1293
- popular images of, 62
- on preconscious, 1300
- on pregenital organization, 1301
- on pregnancy fantasy, 1302
- on prehistory, 1303–1304
- on premonitory dreams, 1305
- on prepsychosis, 1305–1306
- on primal, 1286, 1312
- on primal fantasies, 1307–1308
- on primal repression, 1308–1309, 1485
- on primal scene, 1310–1311
- on primary identification, 788–789, 815, 1313–1314
- on primary narcissism, 148–149, 151, 1110
- on primary need, 1316
- on primary object, 1317
- on primary/secondary processes, 1317–1319, 1328
- on primitive, 1319
- on primitive horde, 1320–1322
- on primitive words, 3–4
- on privation, 1326
- on prohibition, 1331–1332
- on projection, 1334, 1335–1336
- on protective shield, 174, 533, 1340, 1341
- on proton-pseudos, 1342
- on psi system, 1345
- on *Psychanalyse des névroses et des psychoses*, La, 1360–1361
- on *Psychanalyse et les névroses*, La, 1346
- on psyche, 1348
- Psyche* and, 1351
- on psychic apparatus, 1351–1352
- on psychic causality, 1353–1354
- on psychic energy, 1355–1356
- on psychic masochism, 153
- on psychic reality, 1356–1357
- on psychic representative, 1358, 1433
- on psychic structure, 1358–1359
- on psychoanalyst role, 160, 1368, 1369
- on psychoanalytic filiations, 1373
- psychoanalytic nosography and, 1374–1375
- on psychoanalytic research, 1378
- Psychoanalytic Theory of Neurosis*, The and, 1383
- on psychoanalytic treatment, 127, 531, 1068, 1181, 1384–1385, 1456–1457, 1469–1470, 1728–1730
- on psychogenesis/organogenesis, 1391–1392
- on psychogenic blindness, 1392–1393
- on psychology and psychoanalysis, 1397
- on psychoses, 1404, 1418
- on psychosexual development, 1405–1406
- on psychosis/neurosis distinction, 1414, 1415
- on psychosomatic limit, 1410
- on psychosomatics, 1408
- Psychotherapia* and, 1411
- on psychotherapy, 1411, 1412
- on psychotic defenses, 1413
- on psychotic transference, 1419
- on puberty, 1420, 1421
- on puerperal psychoses, 1422
- on punishment dreams, 1422
- on purified-pleasure-ego, 1423
- on purpose of psychoanalysis, 20
- on purposive idea, 1424
- Putnam and, 207, 1424–1425
- on quantitative/qualitative dimensions, 1427–1428
- on quota of affect, 1428, 1433
- Radó and, 1441
- Rank and, 1802, 1859–1860
- on rationalization, 1448
- on reaction-formations, 1449
- on real trauma, 1455
- on reality principle, 1450
- on reality testing, 1450–1451
- on reciprocal paths of influence, 1456
- on regression, 160, 1459–1460
- Reik and, 1463
- on rejection of femininity, 575, 773
- on religion, 158–159, 265–266, 312, 660–661, 899, 1181–1182, 1466–1467, 1855
- on remembering, 1467
- on reminiscences, 1470–1471
- on repetition, 1472, 1473
- on repetition compulsion, 1474–1475
- on repetitive dreams, 1476

## INDEX

Volume 1, pp. 1–662; Volume 2, pp. 663–1344; Volume 3, pp. 1345–1892

- on representability, 1477  
 on representation, 780–782  
 on representation of affect, 1477–1478  
 on repression, 1478–1480, 1482–1484, 1485–1486, 1650  
 on repudiation, 1487  
 on rescue fantasies, 1487–1488  
 on resistance, 1488–1489  
 on resolution of the transference, 1490–1491  
 on return of the repressed, 1491–1492  
 on reversal into the opposite, 1494–1495  
*Revista de psicoanálisis* and, 1496  
*Revista de psiquiatría y disciplinas conexas* and, 1497, 1832  
*Revue française de psychanalyse* and, 1497–1498  
 Rie and, 1502–1503  
 on rituals, 1503–1505  
 on rivalry, 1506  
 Riviere-Hodgson Verrall and, 1507  
*Rivista di psicoanalisi* and, 1508  
 Rolland and, 1511  
 Rosenfeld, Eva Marie and, 1514  
 Russian/Soviet psychoanalysis and, 1518  
 Sachs and, 1523  
 Sadger and, 1524–1525  
 on sadism, 1525  
 on sadomasochism, 388, 1527  
 Sarasin and, 1534  
 Sartre and, 1535  
 Saussure and, 1536  
 on *Schaulust*, 1553  
 Schilder and, 1538  
 Schiller and, 1539  
 on schizophrenia, 1540  
 Schur and, 1548  
 on scientific nature of psychoanalysis, 300–301, 1364, 1550–1551  
 on scotomization, 1554  
 on screen memories, 1555–1556  
 Sechehayé and, 1556  
 on secondary narcissism, 1110–1111  
 on secondary revision, 1558–1559  
 secondary schooling, **1836–1837**  
 Secret Committee and, 1561–1562  
 on secrets, 1560  
 on *Secrets of a Soul, The*, 1563  
 on seduction, 490–491, 669–670, 735, 1563–1566  
 on seduction theory, 1563–1564, 1592, 1754–1755  
 on self, 1567, 1579  
 on self-esteem, 1570  
 on self-hatred, 1571  
 on self-preservation, 1575–1576  
 on self-punishment, 1577  
 on sense/nonsense, 1584  
 on sense of smell, 1616  
 on sexual difference recognition, 1588, 1589  
 on sexual drives, 1589  
 on sexual theories of children, 1590–1591  
 on sexuality, 987, 1593–1594  
 on sexualization, 398  
 on sexuation, 1595  
 on Shakespeare, 1597  
 on shame, 1599  
 siblings of, **632–636**  
 on signal anxiety, 119, 1604  
 on signifiers, 1605  
 Silberer and, 1608  
 Silberstein and, 1609–1610  
 on silence, 1610  
 on skin, 1612, 1613  
 on sleep/wakefulness, 1614  
 on slips of the tongue, 1402–1403, 1615–1616  
 Société Psychanalytique de Paris and, 1625, 1625  
 sociology and, 1632  
 Sokolnicka and, 1633–1634  
 on somatic compliance, 1634–1635  
 on somnambulism, 1636  
 on specific action, 9  
 on specific actions, 1638–1639  
 Spielrein and, 1639  
 Spinoza and, 1640  
 on splitting, 1286–1287, 1645–1646  
 on splitting of the ego, 1233, 1404, 1642, 1647, 1647–1648, 1649  
 on stages, 1651–1652  
 on stammering, 1653  
 Stekel and, 1657  
 Sterba and, 1659  
 Storfer and, 1661–1662  
 Strachey and, 1662–1663  
 Strachey-Sargent and, 1664  
 on stratification, 1665  
 on structural theories, 1666  
 structuralism and, 1668  
*Studienausgabe*, **1669–1670**  
 on subconscious, 1672–1673  
 on subject, 1673, 1675  
 subject's castration and, 1676  
 on sublimation, 1678–1679  
 on substitute formations, 1680, 1681  
 on sucking, 1681–1682  
 on sudden involuntary ideas, 1683  
 on suffering, 1683–1684  
 on suicidal behavior, 1686  
 on suicide, 1687  
 on sum of excitation, 1689–1690  
 on supervised analysis, 1692  
 on suppression, 1693–1694  
 surrealism and, 1695, 1696  
 Swedish psychoanalysis and, 1697  
 Swiss psychoanalysis and, 1549–1550, 1700  
 Swoboda and, 1704  
 on symbiotic relation, 1705–1706  
 on symbol, 1706–1708  
 on symbolism, 1712  
 on symbolization, 1712–1713  
 on symptom-formation, 1716–1717, 1718  
 on symptoms, 1714–1715  
 Szondi and, 1721  
 on taboo, 1723  
 on tact, 1725, 1729  
 Tausk and, 642, 1726, 1727  
 Tegel clinic and, 1734  
 on telepathy, 1181, 1457, 1735  
 on temporality, 1359–1360  
 on tenderness, 1735–1736  
 on termination of treatment, 76–77, 1737, 1738  
 on therapeutic alliance, 1740–1741  
 on Thing, 1743  
 on thing-presentations, 1741–1743, 1874  
 on thought, 1746–1747  
 on thought identity, 1749  
 on tics, 1756  
 on time, 1756–1757  
 Tomasi and, 1758  
 on topographical point of view, 1760  
 on totemism, 1768–1769  
 on training analysis, 1457, 1769–1770  
 on training of the psychoanalyst, 1771  
 on transference, 422, 423, 1469, 1490–1491, 1776–1777  
 on transference hatred, 1781  
 on transference love, 1785–1786  
 on transference neuroses, 1786–1787  
 transference of creativity and, 1787–1788  
 on transference relationship, 1787  
 on transgression, 1791, 1792–1793  
 on translation, 1797–1798  
 on trauma, 328, 1800–1801  
 on traumatic neuroses, 1803–1804

Volume 1, pp. 1–662; Volume 2, pp. 663–1344; Volume 3, pp. 1345–1892

- on truth, 1804–1805  
 on turning around, 1494, 1495, 1806–1808  
 on typical dreams, 1810–1811  
 on uncanny, 1815–1816  
 on unconscious, 1673, 1818–1819, 1820–1821  
 on unconscious concepts, 1817  
 on unconscious fantasies, 1817  
 on undoing, 1821–1822  
 University of Vienna and, 1837–1838  
 on unpleasure, 1826–1827  
 on urethral eroticism, 516–517  
 U.S. psychoanalysis and, 648, 1823, 1824–1825  
 U.S. visit (1909), I:pl.16,17, 60–61, 207, 302–303, 580, 587, 721, 1424, 1822–1823  
 on “vagina dentata” fantasy, 1831  
 Vienna General Hospital and, 1837  
 Vienna Psychoanalytic Society and, 132  
 on violence instinct, 1838–1839  
 on visual, 1840  
 on visual arts, 984, 985, 1841, 1842  
 on voyeurism, 1843  
 Wagner-Jauregg and, 1846  
 Walter and, 1847  
 on war neuroses, 1848  
 on weaning, 1851  
 on Weininger, 1587–1588  
 on *Weltanschauung*, 1854–1855  
 Wiener Cottage Sanatorium and, 1828  
 Wiener psychoanalytische Vereinigung and, 1857  
 on “wild analysis”, 1860–1861  
 on wish-fulfillment, 1864–1865  
 on wishes, 1867  
 on Witch metapsychology, 1868  
 on word association, 1872  
 on word-presentations, 1873–1874  
 on work, 1875–1876  
 on work of the negative, 1129  
 on working-off mechanisms, 1877  
 on working over, 1878  
 on working-through, 1879–1880  
 on *Young Girl's Diary, A*, 1883  
*Zeitschrift für psychoanalytische Pädagogik* and, 1886  
*Zentralblatt für Psychoanalyse* and, 1887  
 Zulliger and, 1888  
 Zweig, Arnold and, 1889–1890  
 Zweig, Stefan and, 1890–1891  
 See also Fliess correspondence; Splits in psychoanalysis  
 Freud, Sigmund Schlomo, works  
 “Acquisition and Control of Fire, The”, 107, 299, 348, 517, 1367–1368  
 “Aetiology of Hysteria, The”, 376, 976, 1040, 1061, 1062, 1064, 1657  
 “Analytic Therapy”, 95  
 “Antithetical Meaning of Primal Words, The”, 3–4, 1495, 1585, 1723  
 “Autobiographical Study, An”, 139–140, 366, 551, 768, 946, 970, 1277, 1475, 1565  
 Biblioteca Nueva de Madrid *Obras Completas*, 175  
 “Case of Paranoia Running Counter to the Psycho-Analytic Theory of the Disease, A”, 848, 1234, 1307  
 “Case of Successful Treatment by Hypnotism, A”, 220, 341, 448, 1560  
 “Character and Anal Eroticism”, 72, 269, 272, 514, 516–517  
 “Civilized Sexual Morality and Modern Nervous Illness”, 298, 299, 311, 797, 804, 1023, 1632, 1750–1751, 1855  
 “Claims of Psycho-Analysis to Scientific Interest, The”, 93, 300–301, 462, 1192, 1293, 1632  
 “Compulsive activities and religious exercise”, 660  
 “Constructions in Analysis”, 65, 96, 337–338, 749, 750, 820, 977, 1310, 1787, 1876  
 “Contributions to the Psychology of Love”, 251–252, 342–343, 1594, 1725  
 “Creative Writers and Day-dreaming”, 107, 351, 443, 551, 555, 985, 1494  
 “Criminals from a Sense of Guilt”, 353  
 “Decomposition of the Psychic Personality”, 1160, 1479  
 “Detaching a Syndrome of Anxiety Neurosis from Neurasthenia”, 364, 420, 1135–1138, 1335, 1878  
 “Difficulty in the Path of Psycho-Analysis, A”, 366, 483  
 “Disposition to Obsessional Neurosis, The”, 72, 269, 288, 514, 746–747, 1179, 1208, 1234, 1301  
 “Dissolution of the Oedipus Complex, The”, 252–253, 641, 789, 1185, 1246, 1480  
 “Dostoyevsky and Parricide”, 351, 412, 413, 431–432, 985, 1071–1072, 1238  
 “Dreams and Telepathy”, 1181, 1476, 1488, 1735  
 “Dreams in Folklore”, 564  
 “Dynamics of Transference, The”, 95, 800, 862, 1127, 1488, 1490, 1610, 1781  
 “Evidential Dream, An”, 746, 1074  
 “Family Romances”, 555, 1494  
 “Fausse reconnaissance (*déjà raconté*) in Psycho-Analytic Treatment”, 381  
 “Female Sexuality”, 254, 516, 641, 1019  
*Five Lectures on Psycho-Analysis*, 303, 587–588, 868, 900–901, 1119, 1164, 1822–1823, 1877  
 “Freud’s Psycho-Analytic Procedure”, 272, 541, 655, 809  
 “Future Prospects of Psycho-Analytic Therapy, The”, 95, 557  
*Gesammelte Schriften*, 175, 680, 1662, 1672  
*Gesammelte Werke*, 176, 680–681, 802, 874  
 “Geschlechtstrieb, Der”, 1589  
 “Heredity and the Etiology of the Neuroses”, 287, 412, 653, 735, 736, 1041, 1178, 1363  
 “Humor”, 50  
 “Hypnosis”, 23  
 “Hysterical Phantasies and their Relation to Bisexuality”, 551, 839–840  
 “Infantile Genital Organization, The”, 252, 365, 415–416, 672, 1184–1185, 1208, 1301–1302  
*Klinische Studie über die halbseitiger Cerebrallähmung der Kinder* (with Rie), 916, 1502  
*Letters of Sigmund Freud 1879–1939, The*, 1601  
*Letters of Sigmund Freud and Arnold Zweig, The*, 1601  
 “Libidinal Types”, 969, 1117  
 “Libido Theory, The”, 372, 485, 1105, 1486, 1538  
 “Lines of Advance in Psycho-Analytic Therapy”, 979–980, 1486  
 “Loss of Reality in Neurosis and Psychosis”, 22, 1234, 1404  
*Mass Psychology and the Analysis of the Ego*, 1293  
 “Medusa’s Head”, 556, 990  
 “Metapsychology”, 323, 786, 805, 838, 1257  
 “Moses of Michelangelo, The”, 985, 1079, 1842  
 “Neurosis and Psychosis”, 21, 22, 465, 1048, 1139, 1234  
 “Note on the Prehistory of the Technique of Analysis”, 356, 616  
 “Note upon the ‘Mystic Writing Pad’, A”, 1042, 1063–1064, 1159–1160, 1340, 1819  
 “Notes on Dream Interpretation”, 443  
*Observations and Analyses Drawn from Analytical Practice*, 1246  
 “Observations on Transference-Love”, 7, 350, 1244, 1785  
 “Obsessions and Phobias: Their Psychical Mechanism and Their Aetiology”, 322, 1274, 1680



Volume 1, pp. 1–662; Volume 2, pp. 663–1344; Volume 3, pp. 1345–1892

- “Obsessive Actions and Religious Practices”, 107, 311, 716, 717, 839, 1466, 1503, 1632, 1723
- On Aphasia*, 127, 403, 539, 781, 802, 847, 1042, 1086, 1873
- “On beginning the treatment”, 422, 541, 616, 664, 835, 1068, 1384
- “On Dreams”, 1190, 1302
- “On Psychoanalysis”, 130
- “On Psychotherapy”, 1411
- “On Repression”, 1281
- “On the Psychic Mechanisms of Hysterical Phenomena”, 225, 384, 767, 768, 1689–1690, 1826
- “On the Universal Tendency to Debasement in the Sphere of Love”, 252, 342, 346, 995, 1319, 1597–1598, 1616
- “On Transformations of Instinct as Exemplified in Anal Erotism”, 252, 514–515, 682, 1069
- “On Transience”, 1080, 1081, 1195–1196
- Opere*, 1199
- Origins of Psycho-Analysis, The*, 802
- “Paths of Psychoanalytic therapy, The”, 586
- Phylogenetic Fantasy, A: Overview of the Transference Neuroses*, 366, 750, 1091–1092, 1093, 1137, 1184, 1278, 1279–1280, 1330
- “Preliminary Communication” (with Breuer), 1470, 1483, 1670
- Psych-analysis and Faith: The Letters of Sigmund Freud and Oskar Pfister*, 1601
- “Psychical, or Mental, Treatment”, 556, 1124, 1353
- “Psychical Mechanism of Forgetfulness, The”, 596, 1351
- “Psycho-Analysis”, 321, 489, 531
- “Psycho-Analysis and Telepathy”, 747, 1181, 1735
- “Psycho-Analysis and the Establishment of the Facts in Legal Proceedings”, 107, 319, 616, 1560
- “Psycho-Analytic View of Psychogenic Disturbance of Vision, The”, 482–483, 1392, 1575
- Psychoanalytic Dialogue: The Letters of Sigmund Freud and Karl Abraham, A*, 1601
- “Psychogenesis of a Case of Homosexuality in a Woman, The”, 757, 817, 1389–1391
- “Psychopathic Characters on the Stage”, 351, 985, 1215
- “Recommendations to Physicians Practicing Psychoanalysis”, 127, 531, 1068, 1181, 1456–1457, 1490, 1729
- “Remarks on the Theory and Practice of Dream-Interpretation”, 1475
- “Reply to Criticisms of My Paper on Anxiety Neuroses, A”, 1136
- “Screen Memories”, 169, 551, 594, 632, 1555, 1609
- “Seventeenth-Century Demonological Neurosis, A”, 1587, 1774
- “Sexual Enlightenment Of Children, The”, 1590
- “Sexuality in the Aetiology of the Neuroses”, 19, 41, 412, 525, 653, 1353
- “Short Account of Psycho-Analysis, A”, 385, 415, 674, 1503–1504
- “Significance of Sequences of Vowels, The”, 1723
- “Some Additional Notes on Dream-Interpretation as a Whole”, 747, 1422
- “Some Character-types Met with in Psycho-Analytic Work”, 269, 272, 1239
- “Some General Remarks on Hysterical Attacks”, 1495, 1680
- “Some Neurotic Mechanisms in Jealousy, Paranoia, and Homosexuality”, 38, 376–377, 549, 1506
- “Some Points for a Comparative Study of Organic and Hysterical Motor Paralyses”, 773–774, 1875
- “Some Psychical Consequences of the Anatomical Distinction between the Sexes”, 253, 416, 570, 641, 668, 1125, 1245, 1635–1636
- “Some Reflections on Schoolboy Psychology”, 26, 1836
- “Special Type of Choice of Object Made by Men, A”, 252, 342, 1183, 1487, 1593
- “Splitting of the Ego in the Process of Defense, The”, 415, 582, 641, 1354, 1647–1648, 1665
- Standard Edition of the Complete Psychological Works of Sigmund Freud*, 68, 94, 698, 753–754, 1558, 1654–1656, 1662–1663, 1664
- “Taboo of Virginity, The”, 251, 252, 342–343, 556, 1109, 1724–1725
- “Theme of the Three Caskets, The”, 1080, 1610, 1739–1740
- Thomas Woodrow Wilson: A Psychological Study* (with Bullitt), 234, 235, 311, 485, 750, 1293, 1743–1745, 1856
- Toward the Preparation of a Metapsychology*, 732
- “Transference”, 95
- “Two Lies Told by Children”, 746, 971
- “Types of Onset of Neurosis”, 653
- “Why War?”, 372, 447, 641, 879, 1097, 1855–1856
- “‘Wild’ Psycho-Analysis”, 61, 855, 1860–1861
- See also* “Analysis, Terminable and Interminable”; *Beyond the Pleasure Principle*; “Child Is Being Beaten, A”; *Civilization and Its Discontents*; *Delusions and Dreams in Jensen’s ‘Gradiva’*; “Disturbance of Memory on the Acropolis, A”; *Ego and the Id, The*; “Fetishism”; Fliess correspondence; “Formulations on the Two Principles of Mental Functioning”; “Further Remarks on the Neuro-Psychoses of Defence”; *Future of an Illusion, The*; *Group Psychology and the Analysis of the Ego*; *Inhibitions, Symptoms, and Anxiety*; “Instincts and Their Vicissitudes”; *Interpretation of Dreams, The*; *Introductory Lectures on Psychoanalysis*; *Jokes and their Relation to the Unconscious*; *Leonardo da Vinci and a Memory of his Childhood*; “Little Hans” case; “Metapsychological Supplement to the Theory of Dreams, A”; *Moses and Monotheism*; “Mourning and Melancholia”; “Negation”; “Neuro-Psychoses of Defense, The”; *New Introductory Lectures on Psychoanalysis*; “On Narcissism: An Introduction”; “On the History of the Psychoanalytic Movement”; “On the Sexual Theories of Children”; “Outline of Psychoanalysis, An”; “Project for a Scientific Psychology, A”; *Psychopathology of Everyday Life, The*; *Question of Lay Analysis, The*; “Remembering, Repeating and Working-Through”; “Repression”; *Studies on Hysteria*; “Thoughts for the Times on War and Death”; *Three Essays on the Theory of Sexuality*; *Totem and Taboo*; “‘Uncanny,’ The”; “Wolf Man” case
- Freud, Sophie. *See* Halberstadt-Freud, Sophie
- Freud, The Secret Passion* (film), 293, 611, **644–645**, 1365
- Freud 1930–1939* (film), 1603
- Freud-Bernays, Martha, I:pl.27, **620–621**, 1735
- Freud et son temps*, 611
- Freud-Jung split, 639, 1643
- analytical psychology and, 79
- Archives de psychologie, Les* and, 116
- Austrian psychoanalysis and, 132–133
- complexes and, 319
- deferred action and, 378
- definition of psychoanalysis and, 1363
- dream interpretation and, 865
- ego and, 463, 469
- extroversion/introversion and, 538
- Freud U.S. visit and, 303
- Freud’s autobiography and, 140

Volume 1, pp. 1–662; Volume 2, pp. 663–1344; Volume 3, pp. 1345–1892

- International Psychoanalytical Association and, 854  
*Jahrbuch der Psychoanalyse* and, 884  
 libido and, 485, 486, 902, 968, 1191  
 Morichau-Beauchant and, 1075  
 myth of origins and, 1322  
 narcissism and, 1191  
 Oberholzer and, 1167  
 “On the History of the Psychoanalytic Movement” and, 639, 1191, 1192–1193  
 Pfister and, 1260  
 prehistory and, 1303  
 “Psychology of the Unconscious, The” and, 1399  
 psychotherapy and, 1411–1412  
 Schreber case and, 1376  
 Secret Committee and, 640, 854, 1193, 1561  
 sexual drives and, 1589  
 Spielrein and, 1639  
 Tausk and, 1726  
*Totem and Taboo* and, 1766  
 transference and, 1779  
 Van Ophuijsen and, 1200  
*Freud Made Easy*, 116  
 Freud Museum (London), 230, **628–629**, 642, 1600  
 Freud-Nathanson, Amalia Malka, **629–631**  
*Freud or Jung* (Glover), 684  
 Freud Professorship (University College, London), 230  
 Freud-Maxism, 1632  
*Freud’s Papers on Technique* (Lacan), 1200–1201  
 “Freud’s Psycho-Analytic Procedure” (Freud), 272, 541, 655, 809  
 Freud’s self-analysis, 638, 1568  
 Anzieu on, 643  
 dreams and, 436, 438, 533  
 fatherhood and, 558  
 Fliess and, 589–590, 628, 1568  
 forgetting and, 596–597  
 Freud, Jakob Kolloman and, 625  
 Freud, Julius and, 425, 633  
 Freud, Philipp and, 633  
 Freud-Nathanson, Amalia Malka and, 629–630  
 German romanticism and, 673  
 hysteria and, 772–773  
 introspection and, 871  
 “Irma’s injection” dream and, 573, 628, 872–873, 1032, 1453, 1502, 1864  
 mysticism and, 1091  
 Oedipus complex and, 425, 551  
 “On Dreams” and, 1190  
 punishment dreams and, 1422  
 reversal into the opposite and, 1494–1495  
 Rie and, 1502  
 Rolland and, 1511  
 Schiller and, 1539  
 Schur on, 628  
 transference of creativity and, 1787–1788  
*Freud’s Self-analysis* (Anzieu), **643**, 754  
*Freud’s Theories of Neurosis* (Hitschmann), 752  
*Freud’s Vienna and Other Essays* (Bettelheim), 172–173  
 Frichet, Anne, 1304  
 Friedan, Betty, 576  
 Friedländer, Saul, 750  
 Friedländer-Fränk, Kate, 343, **645–646**, 697  
 Friedrich, Volker, 679  
 Friendship, **646–648**  
 Fries, Ludwig, 1734  
 Fright, 364, 563, **648**, 1275  
 Frink, Horace Westlake, **648–649**, 906  
 Frischauf, Marie, 1461  
 Frois-Wittmann, Jean, 1695  
*From India to the Planet Mars* (Flournoy), 356  
 “From the History of an Infantile Neurosis”.  
 See “Wolf Man” case  
 Fromm, Erich, 31, **650–652**  
 Brazilian psychoanalysis and, 215  
 Foulkes and, 601  
 Fromm-Reichmann and, 652  
 German psychoanalysis and, 675, 940  
 Horney-Danielson and, 759  
 International Federation of Psychoanalytic Societies and, 852  
 Marxism and, 651, 1017  
 Mexican psychoanalysis and, 651, 1051  
 neopsychoanalysis and, 1131  
 photograph of, I:pl.28  
 on politics, 1293  
 Sachs and, 651, 1523  
 Sigmund Freud Institute and, 1602  
 Sullivan and, 1688  
 Swedish psychoanalysis and, 1698, 1699  
 Thompson and, 1745, 1746  
 U.S. psychoanalysis and, 1824  
*Zeitschrift für psychoanalytische Pädagogik* and, 1886  
 Fromm-Reichmann, Frieda, **652–653**  
 Foulkes and, 601  
 Fromm and, 650–651  
 German psychoanalysis and, 675, 940  
 Groddeck and, 706  
 Pankow and, 1222  
 on psychoses, 1404  
 on psychotic transference, 1419  
 on schizophrenia, 1540  
 Sigmund Freud Institute and, 1602  
 Sullivan and, 1688  
 Swedish psychoanalysis and, 1699  
 Thompson and, 1746  
 Washington Psychoanalytic Society and, 1849  
*Zeitschrift für psychoanalytische Pädagogik* and, 1886  
 Frosch, John, 90, 897  
*Fruits of the Earth, The* (Gide), 1656  
 Frustration, **653–654**  
 active technique and, 8  
 civilization and, 299  
 disintegration anxieties and, 418  
 envy and, 509  
 holding and, 754  
 proto-thoughts and, 1343  
 realization and, 1451  
 self-mutilation and, 1573  
 thought-thinking apparatus and, 1749  
 transference love and, 1785  
 transmuted internalization and, 1798  
 Frustration-aggression Test, 1395  
 Fücks, Siegfried, 652  
 Fuchs, Siegmund Heinrich, 1602  
 Fuentes, Carlos, 241  
 “Function and Field” (Lacan), 1710  
*Function of the Orgasm* (Reich), 1354, 1461  
 Functional phenomenon, **654–655**  
 Fundamental rule, 15, 541, 615, **655–658**  
 See also Free association  
 “Funzione dei conflitti preedipici” (Servadio), 1586  
 Furatdo, Diogo, 1296  
*Furcht*. See Fear  
 Furer, Manuel, 1423  
 Furst, Sidney S., 1600  
 “Further Remarks on the Neuro-Psychoses of Defence” (Freud)  
 on choice of neurosis, 287  
 on compromise formations, 321  
 on defense mechanisms, 376  
 on defenses, 374–375  
 on dipsomania, 412  
 on neuroses, 1138  
 on projection, 1335  
 on psychoses, 1404  
 on repression, 374, 735

## INDEX

Volume 1, pp. 1–662; Volume 2, pp. 663–1344; Volume 3, pp. 1345–1892

- on rituals, 1503  
 on seduction theory, 1755  
 on substitute formations, 1680  
 Furtmüller, Carl, 25  
 Fusco, Marie-Claude, 1617  
 Fusion/defusion, 124, 220, 221, **658–660**  
 Fusion transference, 1059–1060, 1115  
*Future Lasts Forever, The* (Althusser), 53  
*Future of an Illusion, The* (Freud), **660–661**  
 on civilization, 298  
 collective psychology and, 311  
 definition of psychoanalysis and, 1364  
 on disillusionment, 1750  
 on frustration, 653  
 on helplessness, 1439  
 on illusion, 796  
 on myth of origins, 1321  
 Pfister and, 660, 1260  
 on politics, 1293  
 on privation, 1326  
 publication of, 640, 660  
 on religion, 1855  
 Rolland on, 296, 660  
 on taboo, 1723  
 on transgression, 1792  
 on *Weltanschauung*, 1854  
 “Future Prospects of Psycho-Analytic Therapy, The” (Freud), 95, 557
- G**
- Gabbard, Glen O., 209, 296, 853, 898, 1109  
 Gabbard, Krin, 296  
 Gabriel, M., 40  
 Gachkel, Victor, 276  
 Gaddini, Eugenio, **663–664**, 881, 1586  
 Gaddini, Renata, 663  
 Gadelius, Bror, 1697  
 Gagey, Jacques, 560  
 Gain (primary and secondary), 590, **664**, 1385, 1635, 1740  
 Gall, Franz Joseph, 1266  
 Galton, Francis, 720  
 Galván Remus, Estela, 1051  
 Gambier, Luisa. *See* Alvarez de Toledo, Luisa Augusta Rebeca Gambier de  
 Games. *See* Children’s play  
 Gammil, James, 610  
 Gampel, Yolanda, 846, 877, 878, 896  
*Gandhi’s Truth* (Erikson), 511, 1388  
 Gantheret, François, 183, 247, 1163  
 Ganzaraín, Ramón, 284, 285, 888  
 Garat, Dominique, 795  
 Garbarino, Héctor, 1829  
 García, Antonio, 1832  
 García, Roger, 1052  
 García Badaracco, Jorge, 118, 1465  
 García Marquez, Gabriel, 241  
 García Reynose, Diego, 118  
 García Reynose, Gilou, 118  
 Gardiner, Muriel M., **664–665**  
 Brunswick and, 233  
 Freud Museum and, 629  
 photograph of, II:pl.1  
 “Wolf Man” case and, 1221  
 GAREFP (Groupe antillais de recherché, d’étude et de formation psychanalytique), 1014  
 Garma, Angel, **665–666**  
 Alvarez de Toledo and, 55  
 Argentinian psychoanalysis and, 117, 118, 665  
 Cárcamo and, 247  
 Colombian psychoanalysis and, 315  
 Congrès des psychanalystes de langue française des pays romans and, 331  
 Dolto-Marette and, 427  
 on dreams, 1366–1367  
 Federación psicoanalítica de América latina and, 566  
 Martins, Cyro and, 1015  
 Pichon-Rivière and, 1284  
 Rascovsky and, 1447  
 Spanish psychoanalysis and, 1637  
 Garofalo, Raffaele, 353  
 Garon, Josette, 245, 864  
 Garza, Cesar, 1052  
 Gasquères, Evelyne-anne, 1430  
 Gattel, Felix, **666–667**, 674, 1136  
 Gaufay, Guy Le, 1084  
 Gaumont, Marcel, 246  
 Gaupp, Robert, 37, 665  
 Gay, Peter, 491, 642, 900, 1743–1744  
 Gaze, **990–991**  
 cinema and, 295  
 fascination and, 555, 556  
 mirror stage and, 1059  
 object *a* and, 1173  
 optical schema, 1201–1202  
 patient physical position and, 542  
 voyeurism and, 1843  
 Geahchan, Dominique  
 Collège des Psychanalystes and, 314, 612, 1835  
*Confrontation* and, 314, 327, 328, 612, 1835  
*Inconscient, L’* and, 807  
 Viderman and, 1835  
 Gebattel, Viktor Emil Freiherr von Caruso and, 248  
*Évolution psychiatrique, L’* and, 532  
 Marcinowski and, 1011  
 on phenomenology, 1267  
 Wiener psychoanalytische Vereinigung and, 1858  
 Geets, Claude, 843  
*Geheimnisse einer Seele*, 674  
*Gehemmte Mensch, Der* (Schultz-Hencke), 1131  
 Geijerstam, Emanuel af, 1697  
 Geissmann, Claudine, 896  
 Geissmann, Pierre, 896  
*Geisteswissenschaften. See* Anthropology  
 Gelb, Adhemar, 600  
 Geleerd, Elisabeth, II:pl.2, **667–668**  
*Gemeinsame Tagträume* (Sachs), 1524  
 Gemelli, Agostino, 879, 1508  
 Gender development, 1660  
 Gender dysphoria, 1799  
 Gender identity, **668–669**  
 homosexuality and, 757–758  
 identity preservation principle and, 1324  
 masculinity/femininity and, 668–669, 1020  
 Gendrot, Jacques, 1442  
*Généalogie de la psychanalyse* (Henry), 1271  
 General theory of seduction, **669–670**, 1197, 1204, 1342, 1566  
 “Genesis of Psychological Conflict in Earliest Infancy” (Riviere-Hodgson Verrall), 1507  
 Genet, Jean, 1535  
*Genetic Field Theory of Ego Formation, A* (Spitz), 1641  
 Genetic point of view, 1049, 1138, 1667  
 Geneva Psychoanalytic Society, 1700  
*Génie des origines, Le: Psychanalyse et psychoses* (Racamier), 1436  
 Genital love, **670–672**  
 Genital stage, **672–673**  
 Aberastury on, 5  
 adolescence and, 28  
 character and, 271  
 demand and, 388  
 erotogenic masochism and, 518  
 genital love and, 671  
 phobias and, 1275  
 sadism and, 1525  
*Genitalità e cultura* (Fornari), 598  
 Genocide, 358  
*See also* Holocaust  
 Gentile, Giovanni, 879  
 Gentis, Roger, 1766

Volume 1, pp. 1–662; Volume 2, pp. 663–1344; Volume 3, pp. 1345–1892

- Géopsychanalyse*, 241
- Gerlach, Alf, 287
- German psychoanalysis, **674–679**  
Allgemeine Ärztliche Gesellschaft für Psychotherapie and, 49, 1131, 1547  
Kemper, Werner Walther and, 910  
Mitscherlich and, 677, 679, 1060  
Money-Kyrle and, 1069  
*See also* Berliner Psychoanalytische Poliklinik; Berliner Psychoanalytisches Institut; Deutsche Psychoanalytische Gesellschaft
- German Psychoanalytic Society. *See* Deutsche Psychoanalytische Gesellschaft
- German romanticism, **673–674**, 686, 1349, 1686
- Germany. *See* German psychoanalysis
- Gerö, George, 242, 390–391, 1529
- Gero-Heymann, Elisabeth, 360
- Gesammelte Schriften* (Freud), 175, **680**, 1662, 1672
- Gesammelte Werke* (Freud), 176, **680–681**, 802, 874
- “Geschlechtstrieb, Der” (Freud), 1589
- Geschlechstrieben*. *See* Sexual drives
- Gestalt, 1668
- Gestalt theory, 709, 713, 1059
- Gestapo, **681–682**  
*See also* Nazi Germany
- Ghorbal, Mohamed, 1156
- Ghost sites, 114
- Giannotti, Adriano, 880, 881
- Gibault, Alain, 911, 1878
- Gibeault, Alain, 423, 613, 1630
- Gibeault, M., 1500
- Gickhorn, Renée, 627
- Gide, André, 1634, 1656
- Gifts, **682–683**
- Gilgamesh, 1095, 1096
- Gill, Merton, 1446, 1447
- Gillespie, William H., 230, 697, 857
- Gillibert, Jean  
Croatian psychoanalysis and, 1884  
group analysis and, 610  
*Inconscient, L’* and, 807  
on mastery, 1025  
on racism/anti-Semitism, 1439  
*Revue française de psychanalyse* and, 1499
- Gilligan, Carol, 577
- Gillot, Hendrik, 83
- Gimes, Miklós, 766
- Ginburg, Mira, 1703
- Girard, Claude, 1499, 1627, 1803
- Girard, Philippe, 957
- Girard, René, 1322
- GIREP (Groupe International du Rêve Eveillé en Psychanalyse), 414
- Girod, F., 294
- Gisbert, Alfonso, 1833
- Gitelson, Max, 692, 857, 1833, 1888
- Glauber, I. Peter, 568
- Gliserman, Martin, 60
- Global ego, 1675
- Glossary of Psychoanalytical Terms* (Jones), 1553, 1654–1655, 1663
- Glover, Edward, **683–685**  
Abraham, Karl and, 5, 684  
British Psycho-Analytical Society and, 229, 343, 344, 684, 697  
British psychoanalysis and, 696, 697  
on character, 272  
Controversial Discussions and, 343, 344, 997  
on dipsomania, 413  
Eder and, 461  
on failure neurosis, 544  
Fairbairn and, 545  
Friedländer-Fränk and, 646  
on indications/contraindications for psychoanalysis, 809  
photograph of, II:pl.3  
*Psychoanalytic Study of the Child, The* and, 1381  
on psychoanalytic treatment, 1729  
on psychotherapy, 1412  
Schmideberg-Klein and, 1542  
on silence, 1610  
on splitting, 1649  
Strachey-Sargent and, 1664
- Glover, James, **685–686**  
Abraham, Karl and, 5, 684, 685  
on alcoholism, 42  
British psychoanalysis and, 696, 697  
Payne and, 685, 1245  
Sharpe and, 1599
- Gnosticism, 313
- Gobineau, Arthur de, 1437
- Gödel, Kurt, 342
- Godelier, Maurice, 1629
- Godfrey, Clarence, 130
- Goeckel, Rudolf, 1349
- Goethe, Johann Wolfgang von, **686–687**, 984  
applied psychoanalysis and, 107  
Breuer and, 224  
on ego, 475
- Freud and, 686–687, 984, 1838
- German romanticism and, 673
- Groddeck and, 705  
on individuation, 811  
Sarasin and, 1534  
Schiller and, 1539  
sublimation and, 1678  
on suicide, 1686  
superego and, 1690
- Goethe Prize, **687–688**, 1044
- Golan, Shmuel, 877
- Goldberg, Arnold, 279
- Goldberg, Susan, 1304
- Goldman, Emma, 303, 1822
- Goldstein, Kurt, 600, 652, 1047
- Goldstein, Néstor, 566
- Golse, Bernard, 1304, 1652, 1756, 1851–1852
- Gomberoff, Mario, 285
- Gombrich, Ernst Hans, 1825
- Gomes, Martim, 214
- Gomperz, Theodor, 223
- Gondolo-Calais, F., 42
- González, Avelino, 566, 1051
- González, José Luis, 1051, 1052
- Gonzalez, M., 315
- González Pineda, Francisco, 1051, 1052
- Good-enough mother, **688**  
false self and, 546  
handling and, 725  
holding and, 754  
maternal care and, 1029  
object and, 1169  
transitional phenomena and, 1794, 1795, 1862  
true/false self and, 1582
- Goode de Garma, Elisabeth, 117, 315
- Goodman, Paul, 1445
- Goodman, Stanley, 1530, 1532
- Goody, Esther, 1237
- Gordy, Louise, 960
- Gorgone, Georg. *See* Urbantschitsch, Rudolf von
- Göring, Herman, 406, 689
- Göring, Matthias Heinrich, **689**  
Claude and, 305  
Göring Institute and, 406, 676, 689, 1547, 1557  
Laforgue and, 544, 1401, 1625
- Göring Institute. *See* Deutsches Institut für Psychologische Forschung und Psychotherapie
- Gorky, Maxim, 282, 1519

## INDEX

Volume 1, pp. 1–662; Volume 2, pp. 663–1344; Volume 3, pp. 1345–1892

- Göteborg Institute for Psychotherapy, 1700
- Gougoulis, Nicolas, 1629
- Gouhier, Henri, 1350
- Gouttali, Boubker, 1155
- Goya, Francisco de, 1870
- Graber, Gustav Hans, 675
- “Gradiva” (Jensen). *See Delusions and Dreams in Jensen’s “Gradiva”*
- Graf, Herbert, **690**, 1847  
*See also* “Little Hans” case
- Graf, Max, 75, 107, 108, 690, **690–691**
- Graf-Freud, Regina Deborah, **634**
- Graham, Frank W., 131, 132
- Grandiose self, **691**  
alter ego and, 52  
bipolar self and, 184–185  
narcissistic transference and, 1115  
object relations and, 1171–1172  
twinship transference and, 1810
- Grandiosity, 1581
- Granel, Julio, 1423
- Granoff, Wladimir Alexandre, **691–692**  
*Confrontation* and, 327  
on femininity, 574  
French psychoanalytic establishment split (1964) and, 122, 610–611, 957  
Perrier and, 1251  
photograph of, II:pl.4  
*Psychanalyse, La* and, 1348  
Schlumberger and, 1542  
Smirnoff and, 1617  
Société française de psychanalyse and, 692, 1619
- Grant-Duff, Iseult, 685, 696
- Graph of Desire, 554, **692–695**, 895
- Grasset, Bernard, 742
- Grasset, Joseph, 106, 381
- Gray, Paul, 487
- Great Britain. *See* British psychoanalysis
- Great Men: Psychoanalytic Studies* (Hitschmann), 752
- Greed. *See* Money
- Greek psychoanalysis, 498, **700–701**, 922, 1885
- Greek Psychoanalytic Society, 1696
- Green, André  
on anal eroticism, 515  
on anality, 72–73  
on archaic, 112  
on blank psychoses, 191  
Bouvet and, 211  
Colloque sur l’inconscient and, 315, 610  
Congrès des psychanalystes de langue française des pays romans and, 331  
on dead mother complex, 368–369  
on death instinct, 372, 373  
Delay and, 383  
on despair, 1571  
on developmental disorders, 409  
on drives, 447  
on exhibitionism, 535  
French psychoanalysis and, 613  
on fusion/defusion, 659  
on hallucinatory, 722  
on hallucinatory wish-fulfillment, 1867  
on heroic self, 739  
*Inconscient, L’* and, 807  
on infant development, 814  
on infant observation, 818  
“Instincts and Their Vicissitudes” and, 839  
on intergenerational phenomena, 846  
on lack of differentiation, 932  
on myth of origins, 1093  
on mythology, 1097  
on narcissism, 97, 1107, 1111, 1117  
on narcissistic injury, 1113  
on narcissistic withdrawal, 1117  
on negative hallucination, 1125  
on negative therapeutic reaction, 1126, 1782  
on nonverbal communication, 1154  
*Nouvelle Revue de psychanalyse* and, 1162  
on object, 1171  
object relations theory and, 1176  
on Oedipus complex, 1174, 1186  
on patient physical position, 541  
on phallic mother, 1262  
on primary/secondary processes, 1328  
on psychic causality, 1354, 1355  
on psychic representative, 1358  
on psychosomatic limit, 1410  
on quantitative/qualitative dimensions, 1428  
on quota of affect, 1433  
on representation, 781  
*Revue française de psychanalyse* and, 1499  
on sadism, 1526  
on self, 1568  
on self-mutilation, 1573  
on sleep/wakefulness, 1614  
Société psychanalytique de Paris and, 1626, 1627, 1628, 1629, 1630  
structuralism and, 1669  
on transference depression, 1780  
on translation, 1798  
on turning around, 1807  
on work of the negative, 1129–1130, 1876
- Green, Maurice, 1746
- Greenacre, Phyllis, **701–702**  
on allergies, 48  
Bak and, 147  
Canadian psychoanalysis and, 242  
on identity, 794  
on imposter, 122, 803  
*Journal of the American Psychoanalytic Association*, 897  
Lampl-de Groot and, 938  
photograph of, II:pl.5  
*Psychoanalytic Study of the Child, The* and, 1381  
Zetzel-Rosenberg and, 1888
- Greenberg, Clement, 1825
- Greenberg, Joanne R., 652, 1176
- Greenson, Daniel, 1531
- Greenson, Ralph, **702–703**  
on boredom, 203  
on change, 268  
on empathy, 502  
on identity, 794  
*Journal of the American Psychoanalytic Association*, 897  
Los Angeles Psychoanalytic Society/Institute and, 992  
on psychoanalytic treatment, 1729  
on repetition, 1473  
San Francisco Psychoanalytic Society and Institute and, 1529  
on silence, 1610  
on therapeutic alliance, 1741  
on transference relationship, 1787–1789
- Greer, Germaine, 576
- Grégoire, Ménie, 934
- Gressot, Michel, 331, **703–704**, 1152, 1536, 1701
- Greve Schlegel, Germán, 116, 284
- Griaule, Marcel, 1350
- Gribinski, Michel, 124, 1163
- Grid, **704–705**, 1031
- Grief. *See* Mourning
- Griesinger, Wilhelm, Burghölzli Asylum and, 235
- Grieving. *See* Mourning
- Grimaldi, Paulo, 566
- Grinberg, León  
on acting out, 11  
Argentinian psychoanalysis and, 18, 117  
Brazilian psychoanalysis and, 217, 1015  
on counter-identification, 348

Volume 1, pp. 1–662; Volume 2, pp. 663–1344; Volume 3, pp. 1345–1892

- Federación psicoanalítica de América latina and, 566  
 on guilt, 718  
 on hallucinosis, 723  
 Liberman and, 964  
 on primary identification, 1314  
 Spanish psychoanalysis and, 1638  
 on suicide, 1688  
 Swedish psychoanalysis and, 1700  
 Venezuelan psychoanalysis and, 1832–1833  
 Grinberg, Rebeca, 118  
 Grinstein, Alexander, 1600, 1658  
 Groddeck, Georg Walther, 200, **705–707**  
 cryptomnesia and, 356  
 Fromm-Reichmann and, 652  
 German psychoanalysis and, 674  
 on id, 777  
 photograph of, II:pl.6  
 on psychic causality, 1354  
 on psychosomatics, 1408  
 on relaxation principle/neo-catharsis, 1465  
*Zeitschrift für psychoanalytische Pädagogik* and, 1886  
 Groen, Jan, 1133  
 Groen-Prakken, Hanna, 1885  
 Groethuysen, Bernard, 1493  
 Groos, Karl, 1472  
 Gros, J.-P. Durand de, 768, 973  
 Grosclaude, Michèle, 390  
 Gross, Alfred, 1734  
 Gross, Otto Hans Adolf, 674, **707–708**, 1293  
 Grote, Louis R., 1044  
 Grotjahn, Martin, 852, 992, 1045, 1348  
 Grotstein, James, 1423, 1852  
 Group (Neri), 709–710  
 Group analysis, **709–710**  
 British psychoanalysis and, 699  
 Burrow on, 237–238  
 family therapy and, 1371  
 Foulkes on, 601, 709  
 French psychoanalysis and, 610, 613  
 Group illusion, 738–739  
 Group phenomenon, **710–711**  
*See also* Group analysis; Groups  
*Group Psychology and the Analysis of the Ego* (Freud), **712–713**  
 on anthropology, 93  
 applied psychoanalysis and, 107  
*Civilization and Its Discontents* and, 297  
 collective psychology and, 311, 712  
 on conflict, 326  
 on death instinct, 372  
 on ego, 464, 712  
 on ego ideal, 1106  
 on fascination, 555–556  
 heroic identification and, 739  
 on identification, 640, 788, 1083, 1314  
 on incest, 804  
 on inferiority feelings, 831  
 Jankélévitch and, 887  
 Le Bon and, 953–954  
 on libido, 967  
 on literature, 1094  
 on mania, 1006  
 on myth of origins, 712, 713, 1321  
 on narcissism of minor differences, 1109  
 on self-consciousness, 1570  
 on otherness, 1214  
 publication of, 753  
 on racism/anti-Semitism, 1438  
 on secondary narcissism, 1111  
 sociology and, 1632  
 structural theory and, 174  
 on superego, 1690  
*Totem and Taboo* and, 1767  
 Group psychotherapies, **713–714**  
 Aberastury's use of, 5  
 analytic psychodrama, 77–78  
 Australian psychoanalysis and, 132  
 Bion on, 184  
 Moreno on, 713, 1072  
*See also* Group analysis  
 Groupe antillais de recherché, d'étude et de formation psychanalytique (GAREFP), 1014  
 Groupe d'études philosophique et scientifiques pour l'examen des idées nouvelles, 45, 46, 204  
*Groupe et le Sujet du groupe, Le* (Kaës), 710  
*Groupe et l'Inconscient, Le* (Anzieu), 710  
 Groupe française de Montréal, 1621  
 Groupe International du Rêve Eveillé en Psychanalyse (GIREP), 414  
 Groups  
 alienation and, 44  
 Anzieu on, 104  
 basic assumptions and, 151, 709–710, 711  
 Bion on, 183, 184, 601, 709, 710–711, 713, 1371  
 collective psychology and, 311  
 ego ideal and, 480  
 family and, 547  
 heroic identification and, 738–739  
 Le Bon on, 953–954  
 paranoia and, 1227  
 relations model and, 1464  
*See also* Balint groups; Group analysis  
 Grubrich-Simitis, Ilse, 623, 681, 1199, 1601, 1669–1670  
 Grünbaum, Adolf, 1271, 1370, 1378, 1517  
 Grunberger, Béla  
 on agency, 33  
 Congrès des psychanalystes de langue française des pays romans and, 330  
 French psychoanalysis and, 613  
 on narcissism, 97, 1107, 1111  
 on narcissistic elation, 1112  
 on narcissistic injury, 1113  
 on narcissistic transference, 1115  
*Psyché* and, 1350  
 on racism/anti-Semitism, 1438–1439  
 on sadism, 1526  
 on silence, 1610  
 Société psychanalytique de Paris and, 1626  
 on student protests (1968), 612  
 Torok and, 1764  
 Viderman and, 1834  
*Grundformen der Angst* (Riemann), 1131  
*Grundformen un Erkenntnis menschlichen Daseins* (Binswanger), 181  
*Grundlagen der Psychoanalyse, Der* (Hartmann), 727  
 Grupo Luso-Español de psicoanálisis, 1637  
*Gruppo e Funzione Analitica*, 347  
 Guattari, Félix, 97–99, 612, 1293  
 Gudden, Bernhard von, 235  
 Guedeny, Colette, 911  
 Guedeny, Nicole, 1297  
 Guedes, P., 216  
 Guex, Germaine, 2, **714–715**, 715, 1536, 1701  
 Guignard, Florence, 830, 1014, 1297  
 Guilbert, Yvette, **715–716**  
 Guild, Julius, 244  
 Guilhot, Jean, 415  
 Guilhot, Marie-aimee, 415  
 Guillaumin, Jean  
 French psychoanalysis and, 613  
 on incompleteness, 805  
 on intergenerational phenomena, 845  
 on internal/external reality, 847, 848  
 on object, 1171, 1172  
 Société psychanalytique de Paris and, 1628  
 Guilt, **716–718**  
 Ajase complex and, 39  
 anxiety and, 100, 101  
 breast as good/bad object and, 219  
 criminology and, 353

## INDEX

Volume 1, pp. 1–662; Volume 2, pp. 663–1344; Volume 3, pp. 1345–1892

- depression and, 394  
depressive position and, 395, 396  
early Oedipus complex and, 1188  
ego and, 470, 471, 716, 717  
ethics and, 525, 526  
identification with the aggressor and, 792–793  
inferiority feelings and, 831  
introjection and, 870  
jouissance and, 894  
masochism and, 717, 1022  
masturbation and, 1026  
melancholia and, 21  
modesty and, 1067  
moral masochism and, 717, 1022, 1071  
myth of origins and, 1321  
mythology and, 1096–1097  
need for punishment and, 1120  
negative therapeutic reaction and, 1125, 1126  
Oedipus complex and, 353  
parricide and, 1078, 1092, 1239  
representation and, 781  
rituals and, 1504  
secrets and, 1561  
self-mutilation and, 1573  
self-punishment and, 1577  
superego and, 297, 471, 716–717, 1690, 1691  
Guimarães Dahlheim, Luiz, 215, 1833  
Guimarães de Almeida, Edgar, 215  
Guiraud, Paul, 314, 1152  
Gulag, 44  
Gull, William, 91  
Gumbel, Erich, 877  
Gundert, Hermann, 675, 677  
Guntrip, Harry, 191, 577  
Gustin, John, 1380  
Gutheil, Thomas G., 209  
Gutton, Philippe, 27, 1420–1421  
Guyomard, Patrick, 526, 611, 612, 1084  
Guyotat, Jean, 845, 846  
*Gyermekszoba pszichológiája, A* (Balint-Szekely-Kovács), 149  
Gyömrői, Edit, 764, 766
- H**  
Haag, Antje, 287  
Haag, Geneviève, 178, 896, 1304, 1682, 1806  
Haag, Michel, 1304, 1794  
Haarstrick, Franz Rudolf, 677  
Haas, Ladislav, 361  
Haass-Wiesegart, Margarethe, 286–287  
Häberlin, Paul, 1702  
Habermas, Jürgen, 31, 1061  
Hacheva Hapsychoanalytit be Israel. *See* Israeli Psychoanalytic Society  
Haddad, Gérard, 900  
Haddadi, Djamilia, 1155  
Hadfield, James Arthur, 686, 1457  
Hadley, Ernest, 1849  
Haeckel, Ernest  
  Darwinism and, 366, 367  
  Ferenczi and, 1738  
  heredity of acquired characters and, 736  
  monism and, 1070  
  myth of origins and, 1322  
  on ontogenesis, 1196–1197, 1277, 1278, 1330  
  on prehistory, 1303  
Haenel-Guttman, Irene, 1734  
Haffani, Fakhredinne, 1155  
Haitzmann case, 1587, 1774  
Hajdu, Lilly, 766  
Halayem, Mohamed, 1155, 1156  
Halberstadt-Freud, Ernst, 719, 745, 818  
Halberstadt-Freud, Sophie, 372, 640, 719–720  
Hale, Nathan G., Jr., 62, 1823  
Haley, Jay, 433  
Haley, Thomas, 853  
Hall, Granville Stanley, 720–721  
  Freud U.S. visit and, I:pl.16, 60, 207, 302–303, 721  
  on ontogenesis, 1197  
  U.S. psychoanalysis and, 1822  
Halliday, James L., 1407  
Hallucinatory, the, 721–722  
  action-presentations and, 12  
  constructions and, 338  
  *déjà vu* and, 381–382  
  delusions and, 386  
  disintegration products and, 419  
  dreams and, 438  
  experience of satisfaction and, 536  
  Ey on, 540  
  good-enough mother and, 1582  
  internal/external reality and, 847  
  negative, 1124–1125, 1130, 1477  
  object and, 1169  
  omnipotence of thoughts and, 1189  
  perceptual identity and, 1249  
  primary need and, 1316  
  psychic reality and, 1357  
  reality testing and, 1451  
  Schreber case and, 1376  
  splitting and, 1646, 1647, 1648  
  subject's desire and, 1677  
  symbiosis and, 1705  
  symbolic equation and, 1709  
  symbolization and, 1713  
  symptoms and, 1715  
  thought identity and, 1749  
  work of the negative and, 1130  
Hallucinatory wish-fulfillment, 1865–1867  
  amentia and, 58  
  Fantasy and, 551  
  primary/secondary processes and, 1318  
  projection and, 1336  
  reality principle and, 1450, 1866  
  word-presentations and, 1873  
Hallucinogenic drugs, 55, 386  
Hallucinoses, 722–723  
Halsmann, Philipp, 353  
*Hamlet* (Shakespeare), 27, 107, 294, 985, 1096, 1238, 1597  
*Hamlet and Oedipus* (Jones), 723–724  
Hampstead Clinic/War Nurseries, 281, 619, 697, 724  
  Burlingham-Tiffany and, 236  
  child analysis and, 1732  
  Friedländer-Fränk and, 646  
  Hellman Noach and, 733  
  Hietzing Schule and, 745  
  Hoffer and, 752  
  Ross and, 1516  
  Sandler and, 1533  
Handling, 724–725, 843  
*Hands of the Living God, The* (Blackett-Milner), 190  
Hann, Fanny, 765  
Hanna Perkins Center for Child Development, 908  
Hanold, Norbert, 103  
Hansen, Erik Bjerg, 391  
Hansen, Finn, 1158  
Happel, Clara, 675, 725–726  
Hard science, 726–727  
  *See also* Scientific nature of psychoanalysis  
Hargreaves, Ronald, 1458, 1728  
Harnack, Arvid, 1506  
Hárník, Jenő, 166, 390, 765, 910  
Harris, Martha, 818, 880, 1728, 1732  
Hart, Bernard, 696, 989  
Hartenberg, Paul, 1136  
Hartmann, Eduard von, 1268, 1349, 1683  
Hartmann, Heinz, 727–728, 1548  
  on adaptation, 22, 475, 488  
  Bak and, 147

Volume 1, pp. 1–662; Volume 2, pp. 663–1344; Volume 3, pp. 1345–1892

- on character, 273  
 on childhood, 281  
 on defenses, 375, 377  
 definition of psychoanalysis and, 1364  
 on desexualization, 399  
 Dolto-Marette and, 427  
 on ego, 466, 468, 477, 486  
 on ego autonomy, 466, 473–474  
 on ego functions, 478, 488  
 on ego interests, 484  
 on ego-libido/object-libido, 486  
 ego psychology and, 466, 475, 476, 477, 727, 728, 1576  
 Favez and, 560  
 French psychoanalysis and, 608  
 Freud, Anna and, 619  
 Greenacre and, 702  
 Hogarth Press and, 753  
 on id, 779  
 on identification, 790  
 on internal/external reality, 848  
 Isakower and, 874  
 Jacobson and, 883  
 Japanese psychoanalysis and, 888, 921–922  
 Kris and, 925  
 Lampl-de Groot and, 938  
 Lehrinstitut der Wiener psychoanalytischen Vereinigung and, 959  
 on libido, 969  
 on metapsychology, 1049  
 Nacht and, 1101  
 on neurotic defenses, 1142  
 on neutrality, 1144  
 New York Psychoanalytic Institute/Society and, 1148  
 on object, 1171  
*Psyche* and, 1351  
*Psychoanalytic Study of the Child, The* and, 492, 728, 1381  
 psychology and psychoanalysis and, 1398  
 on psychosexual development, 1407  
 Radó and, 727, 1441  
 Schilder and, 1538  
 Second World War and, 1557  
 on self, 1567, 1579  
 on self-image, 1571  
 on self-representation, 1578  
 Société psychanalytique de Paris and, 1625  
 on stages, 1652  
 on structural theories, 1667  
 structuralism and, 1669  
 U.S. psychoanalysis and, 1825  
 Wagner-Jauregg and, 1846
- Wiener psychoanalytische Vereinigung and, 1857  
*See also* Ego psychology  
 Hartocollis, Pierre, 701  
 Harzallah, Khalifa, 1155  
 Hassoun, Jacques, 1156  
 “Hate in the Counter-Transference” (Winnicott), 1782  
 Hatred, **728–729**  
 environment and, 1862  
 links of, 995–996  
 narcissism of minor differences and, 1109  
 of self, 41, 1126, 1570–1571, 1588  
 transference and, 1781–1782  
 “Why War?” on, 1856  
 Hattingberg, Hans von, 1011, 1505  
*Haunting Melody, The: Psychoanalytic Experiences in Life and Music* (Reik), 1088  
 Häutler, Adolf, 1091  
 Haynal, André, 1701  
 H.D.. *See* Doolittle-aldington, Hilda  
 Head, Henry, 1538  
 Head banging, 1573  
 Hegel, Georg W. F.  
 on alienation, 43  
 Althusser and, 53  
 Austrian psychoanalysis and, 134  
 Breton and, 224  
 on civilization, 298  
 constructions and, 335, 337  
 Lacan and, 1270–1271  
 monism and, 1070  
 on otherness, 1214, 1271  
 on passion, 1243  
 on phenomenology, 1266  
 pleasure in thinking and, 1289  
 on recognition, 53  
 on self-consciousness, 1569  
 surrealism and, 1695  
 on thought identity, 1749  
 on work of the negative, 1129  
 Heidegger, Martin  
 Binswanger and, 181  
 Brentano and, 222  
 Lacan and, 930, 1270, 1271  
 Marcuse and, 1013  
 on phenomenology, 1266, 1267  
*Psyché* and, 1350  
 Schultz-Hencke and, 1547  
 Swiss psychoanalysis and, 1703  
 Heigl, Franz, 677  
 Heigl-Evers, Anneliese, 677
- Heilborn, Hanna, 360, 992  
 Heimann, Paula, **729–730**  
 Argentinian psychoanalysis and, 118  
 on change, 268  
 child analysis and, 698  
 Controversial Discussions and, 343, 344, 697  
 on counter-transference, 350, 1440  
 on dependence, 392  
 on empathy, 502  
 German psychoanalysis and, 1060  
 Klein and, 510  
 on paranoid position, 1231  
 Heine, Heinrich, 434, 673, 686, 891, 899  
 Heinrich-Schultz, Johannes, 1131  
 Heinroth, J. C. H., 1407  
 Heisenberg, Werner, 401  
 Held, René, **730–732**  
 Congrès des psychanalystes de langue française des pays romans and, 331  
 French psychoanalysis and, 609  
 Måle and, 1004  
 Nacht and, 731, 1102  
 Société psychanalytique de Paris and, 731, 1626  
 Hellens, Franz, 157, 423  
 Heller, Hugo, 351, 404, **732–733**, 860  
 Heller, Maggie, 732  
 Heller, Peter, 745  
 Heller, Theodore, 827  
 Hellman Noach, Ilse, 131, 697, **733–734**  
 Hellmuth, Hermine von. *See* Hug-Hellmuth-Hug von Hugenstein, Hermine  
 Helmholtz, Hermann von, 322, 866  
 Helplessness, 2, **734–735**  
 act/action and, 9  
 annihilation anxieties and, 90  
 dependence and, 392  
 experience of satisfaction and, 536  
 infant development and, 814  
 narcissistic injury and, 1112  
 phobias and, 1275  
 racism/anti-Semitism and, 1439  
 trauma and, 1801  
 Henderson, A. F., 1297  
 Henderson, Joseph L., 1581  
 Henderson Hospital, 700  
 Hendrick, Ives, 207, 1849  
 Henny, René, 1701  
 Henri, Claude, 988  
 Henri-Rousselle Hospital, 1528  
 Henry, Michel, 1271  
*Henry, Portrait of a Serial Killer* (film), 292



## INDEX

Volume 1, pp. 1–662; Volume 2, pp. 663–1344; Volume 3, pp. 1345–1892

- Herbart, Johann Friedrich  
Andersson on, 82  
Brentano and, 222, 223  
Kantianism and, 905  
psychology and psychoanalysis and, 1397  
on repression, 1482  
Swedish psychoanalysis and, 1699
- Hercules, 299
- Herder, Johann, 686
- “Heredity and the Etiology of the Neuroses” (Freud), 287, 412, 653, **735–736**, 1041, 1178, 1363
- Heredity of acquired characters, **736–737**
- Hermann, Imre, **737–738**  
on anti-Semitism, 291, 1438  
Bak and, 146, 147  
on clinging instinct, 307, 737, 1438  
Hungarian psychoanalysis and, 765  
Hungarian School and, 763, 764  
Kovács-Prosznitz and, 923  
Nazi Germany and, 766  
on shame, 1599  
Szondi and, 1721
- Hermanns, Ludger, 679
- Hermeneutics, 68, **738**, 863
- Hernández, Max, 1254
- Hero myth, **1094–1095**
- Heroic identification, **738–739**, 790, 1095
- Heroic self, **739–741**
- Herold, Karl Maria, 1734
- Herrmann, Fábio Antonio, 566
- Hersant, Yves, 1628
- Hertz, Dan, 877
- Herzl, Theodor, 1503
- Hesitation, doubt and, 435
- Hesnard, Angélo Louis Marie, **741–743**  
Claude and, 305  
Congrès des psychanalystes de langue française des pays romans and, 329  
*Disque vert, Le* and, 423, 424  
on ethics, 525  
*Évolution psychiatrique, L’* and, 532, 742, 933
- Favreau and, 561
- French psychoanalysis and, 607–608
- Lacan and, 38
- North African psychoanalysis and, 1155  
*Psychanalyse des névroses et des psychoses, La*, 134, 607, 741, 1345, 1360–1362, 1459  
*Psyché* and, 742, 1350  
*Revue française de psychanalyse* and, 200, 742, 934, 1497, 1498
- Société psychanalytique de Paris and, 742, 1619, 1623, 1624
- Hesse, Hermann, 50, 674
- Heteroglossia, 1643
- Heterosexuality, **743–744**, 1660
- Heuyer, Georges, **744–745**  
analytic psychodrama and, 78  
Berge and, 161  
Borel and, 204  
Clark-Williams and, 303  
Diatkine and, 410  
Favez and, 560  
Favez-Boutonier and, 559  
on infantile psychosis, 824  
on infantile schizophrenia, 827  
Lacan and, 36, 929  
Lebovici and, 954  
Mâle and, 1004  
Morgenstern-Kabatschnik and, 1073  
*Psyché* and, 1350  
Smirnoff and, 1617  
Sokolnicka and, 304–305, 744  
Sokolnicka-Kutner and, 1634
- Heyer, Carl Gustav, 1011
- Hidden Symbolism of Alchemy and the Occult Arts* (Silberer), 71
- Hiding/showing, 1067
- Hietzing Schule, 236, 510, **745**, 1513
- Higgins, John W., 413
- Hilbert, David, 1378, 1550
- Hilferding-Hönigsberg, Margarethe, **746**  
*Hilflosigkeit*. See Helplessness
- Hill, Lewis, 1849
- Hillman, James, 115
- Hinojosa, Ruben, 1052
- Hinshelwood, Robert D., 396, 1339
- Hirschfeld, Elfriede, **746–748**
- Hirschfeld, Magnus, 674, 757, 1799
- Hirschmüller, Albrecht, 89, 1223
- Hirt, Jean-Michel, 1156
- Historical point of view, 1049
- Historical reality, **748–749**  
constructions and, 335, 338  
developmental processes and, 1330  
fantasy and, 552  
mnemonic traces and, 1064
- Historical truth, **749–750**  
amnesia and, 65  
anticipatory ideas and, 96  
constructions and, 338  
“Dora” case and, 604  
remembering and, 1468
- History, **750–751**  
Certeau on, 266–267  
id and, 778  
mythology and, 1096  
psychohistory, 511, 986, 1293, 1393–1394  
*History and Psychoanalysis: An Inquiry into the Possibilities and Limits of Psychohistory* (Friedländer), 750  
History of psychoanalysis, 613, 1058  
See also “On the History of the Psychoanalytic Movement”  
*History of Psychoanalysis in Canada* (Parkin), 244  
Hitchcock, Alfred, 293, 294, 1365  
Hitler, Adolf. See Nazi Germany  
Hitschmann, Eduard, **751–752**  
on Bergler, 163  
Finnish psychoanalysis and, 584  
Foulkes and, 601  
Isakower and, 874  
*Jahrbuch der Psychoanalyse* and, 884  
Lehrinstitut der Wiener psychoanalytischen Vereinigung, 959  
photograph of, II:pl.7  
*Psychoanalytische Bewegung, Die* and, 1387  
Sterba and, 1659  
Swedish psychoanalysis and, 1698  
Vienna Ambulatorium and, 568, 958, 959  
Wiener psychoanalytische Vereinigung and, 1857  
Winterstein and, 1863  
Hitzig, Eduard, 235  
Hobaica, W., 1832  
Hoch, August, 227, 1547  
Hofer, Johannes, 1158  
Hoff, Hans, 133  
Hoffer, Alex, 1144  
Hoffer, Hedwig, 1533  
Hoffer, Willi, **752–753**  
Controversial Discussions and, 343, 697  
German psychoanalysis and, 1060  
*Gesammelte Werke* and, 680  
Hartmann and, 727  
*International Journal of Psychoanalysis, The* and, 853  
Lehrinstitut der Wiener psychoanalytischen Vereinigung and, 959  
Mahler-Schönberger and, 1001  
photograph of, II:pl.8  
Sandler and, 1533  
Sterba-Radanowicz-Hartmann and, 1658  
Vienna Ambulatorium and, 959

Volume 1, pp. 1–662; Volume 2, pp. 663–1344; Volume 3, pp. 1345–1892

- Wiener psychoanalytische Vereinigung and, 1857
- Hoffer-Schaxel, Hedwig, 959
- Hoffman, Ernst, 157, 450, 956
- Hoffmann, E. T. A., 1393, 1815
- Hofstein, Francis, 1552
- Hogarth Press, 698, **753–754**
- Holden, Jeni, 1297
- Holder, Alex, 1533
- Holding, **754–755**  
 dead mother complex and, 369  
 frame of psychoanalytic treatment and, 607  
 integration and, 843  
 true self and, 1582
- Holistic societies, 810
- Holland. *See* Dutch psychoanalysis
- Holland, Norman, 987, 1597
- Hollitscher-Freud, Mathilde, **755–756**
- Hollós, István, 347, 580, **756**, 765–766, 766
- Holman, Portia, 177
- Holmes, Gordon, 1414
- Holmström, Reijo, 584
- Holocaust  
 alienation and, 44  
 anti-Semitism and, 1437  
 Bettelheim on, 172, 173, 503  
 Bick and, 177  
 cultural transmission and, 358  
 failure neurosis and, 544  
 Happel and, 726  
 Israeli psychoanalysis and, 877  
 Judaism and, 900  
*See also* Anti-Semitism; Nazi Germany
- Holstijn, Westerman, 1133
- Holt, E. B., 1860
- Holt, Robert R., 1517
- Holter, Peter Andreas, 1157, 1158
- Holzman, Phillip, 8
- Home for the Heart, A* (Bettelheim), 173
- Home of the Brave* (film), 292
- Homer, 1348
- “Homme au magnétophone, L””, 612
- Homme escave de son infériorité, L* (Odiar), 1182
- Homosexuality, **756–758**  
 abstinence and, 8  
 activity/passivity and, 17  
 alcoholism and, 41  
 altruism and, 54  
 anal eroticism and, 514  
 anality and, 72  
 Boehm on, 199  
 delusions and, 386  
*Diagnostic and Statistical Manual of Mental Illness* on, 993  
 erotomania and, 521–522  
 female sexuality and, 365, 571  
 fetishism and, 583  
 Freud on, 757, 758, 1389–1391  
 friendship and, 647  
 identification and, 787  
 libido and, 969  
 Morselli on, 1076  
 narcissism and, 1190  
 Nazi Germany and, 1438  
 Other and, 1213  
 paranoia and, 757, 1227, 1229–1230, 1231  
 perversion and, 1255  
 phallic mother and, 1261, 1264  
 phobias and, 1274  
 pregnancy fantasy and, 1303  
 projection and, 1335  
 puberty and, 1420  
 Rank on, 1445  
 Sadger on, 1524–1525  
 Saussure, Raymond de on, 1536  
 Schreber case and, 757, 1227, 1229, 1230, 1232, 1377, 1545, 1546, 1587  
 secondary narcissism and, 1111  
 social feeling and, 1618  
 Stoller on, 1660  
 sublimation and, 1679  
 suicide and, 1686, 1687  
 symptom-formation and, 1717  
 term origins, 743, 756–757  
 transsexualism and, 1799  
 Weininger on, 1588
- Honegger, Johann Jakob, 1702
- “Honte comme angoisse sociale, La” (Hermann), 1599
- Hopkins, Juliet, 1732
- Hopkins, Pryn, 1497
- Horkheimer, Max, 31  
 Foulkes and, 601  
 German psychoanalysis and, 675, 677, 940  
 Institute for Social Research and, 1013, 1602  
 Sigmund Freud Institute and, 1602
- Horn, M. W., 300
- Horney-Danielson, Karen, **758–760**  
 Abraham, Karl and, 5  
 Adorno and, 31  
 American Psychoanalytic Institute and, 58  
 Association for the Advancement of Psychoanalysis and, 1558, 1644, 1745–1746  
 Australian psychoanalysis and, 132  
 Berliner Psychoanalytische Poliklinik, 675  
 Berliner Psychoanalytisches Institut and, 166  
 Brazilian psychoanalysis and, 215  
 Croatian psychoanalysis and, 1884  
 on culture, 58, 59, 759, 1824  
 definition of psychoanalysis and, 1364  
 Deutsch-Rosenbach and, 405  
 on female sexuality, 365, 571, 574, 576, 1186  
 on femininity, 59  
 Fromm and, 651  
 German psychoanalysis and, 674  
 Heimann and, 730  
 on memory, 1043  
 neopsychanalysis and, 1131  
*Neurosis and Human Growth*, 759, 1140–1141  
 on penis envy, 1246  
 photograph of, II:pl.9  
*Psyché* and, 1350  
 Sachs and, 1523  
 Schmideberg-Klein and, 1542  
 Swedish psychoanalysis and, 1699  
 Thompson and, 1745  
 U.S. psychoanalysis and, 1824
- Horowitz, Milton, 989
- Hospital (consultation) psychiatry, 208
- Hospitalism, 70, 397, 760, **760–761**, 1641  
 “Hospitalism” (Spitz), 70
- Houzel, Didier  
 on attention, 127, 128  
 Bick and, 178  
 child analysis and, 1731, 1783  
 on infant observation, 817–818  
 on infantile psychosis, 825  
*Journal de la psychanalyse de l'enfant* and, 896  
 on night terrors, 1149  
 Portuguese psychoanalysis and, 1297  
 on sleep/wakefulness, 1615  
 on somnambulism, 1636
- How Does Analysis Cure?* (Kohut), 920, 1574, 1810
- Hsueh Jen Keui*, 285
- Hubback, C. J. M., 861
- Hufeland, C. W., 412
- Hug-Hellmuth-Hug von Hugenstein, Hermine, **761–762**

## INDEX

Volume 1, pp. 1–662; Volume 2, pp. 663–1344; Volume 3, pp. 1345–1892

- child analysis and, 279, 283, 761–762, 1731  
 definition of psychoanalysis and, 1363  
 Klein and, 915  
 Vienna Ambulatorium and, 959  
*Young Girl's Diary, A*, 761–762, 1883
- Hughlings Jackson, John. *See* Jackson, John  
 Huglings
- Huguenin, Gustav, 235
- Human Mind, The* (Menninger), 1045
- Human Motives* (Putnam), 1425
- Human Relations*, 1728
- Humanism, 1668
- Humanist psychology, 26, 615, 759
- Humor, **762–763**  
 creativity and, 352, 890  
 empathy and, 502  
 Freud's Gestapo comment, 681–682  
 jokes, 325, 890–892, 1584–1585  
 repetition and, 1473  
 sense/nonsense and, 1584–1585  
 "Humor" (Freud), 50  
 "Humour et la folie" (Racamier), 1226
- Hungarian psychoanalysis, **764–767**  
 Ferenczi and, 580  
 Hollós and, 756  
 Kovács-Prosznitz and, 923  
 Róheim and, 765, 766, 1510  
*See also* Hungarian School
- Hungarian Psychoanalytic Association, 765, 766, 1441
- Hungarian Psychoanalytic Society, 1661
- Hungarian School, 146–147, 148, 700, **763–764**, 766, 923
- Hunger, 171, 483
- Hunger orgasm, 91
- Huo Datong, 287
- Hupka, Joseph, 353
- Huss, Magnus, 40
- Husserl, Edmund  
 Binswanger and, 181  
 Brentano and, 222  
 on phenomenology, 1266, 1267  
 Sartre and, 1534  
 Schilder and, 1537  
 Schultz-Hencke and, 1547  
 on self-consciousness, 1569  
 Swedish psychoanalysis and, 1699  
 Swiss psychoanalysis and, 1703
- Huston, John, 293, 611, 644, 1365
- Huxley, Aldous, 44
- Hypercathexis, 260, **767**  
 attention and, 127  
 conscious processes and, 332  
 perception-consciousness system and, 1248  
 protective shield and, 1340  
 trauma and, 1801  
 word-presentations and, 1873
- Hypersyntony, 1006
- Hypnagogic processes, 71
- Hypnoid states, **768**
- Hypnoidia, 1671
- Hypnosis, **768–770**  
 alcoholism and, 40  
 alienation and, 44  
 animal magnetism and, 84–85  
 "Anna O." case, 88, 225, 258, 768  
 autosuggestion and, 144  
 Bernheim on, 170  
 Bose on, 206  
 cathartic method and, 258  
 Charcot on, 275  
 Chertok and, 277  
 cinema and, 292, 294  
 Congrès international de l'hypnotisme expérimental et scientifique and, 331–332  
 cure and, 358  
 "Emmy von N." case and, 499, 500  
 fascination and, 555, 556  
 German romanticism and, 673  
 hypnoid states and, 768  
 Liebeault and, 972–973  
 lifting of repression and, 1486  
 "Lucy R." case and, 997–998  
 negative hallucination and, 1124  
 Putnam on, 1424  
 splitting and, 1645  
 sudden involuntary ideas and, 1683  
 superego and, 1690  
 surrealism and, 1695  
 trance and, 1774  
 working-through and, 1879  
 "Hypnosis" (Freud), 23
- Hypnotism, suggestion and, 1684
- Hypochondria, **770–771**  
 as actual neurosis, 19  
 anal eroticism and, 514  
 body image and, 198  
 breast as good/bad object and, 219  
 erotogenic zones and, 519  
 erotogenicity and, 521  
 Freud and, 640
- Hypocritical dreams, **771–772**
- Hyppolite, Jean, 315, 610, 1123
- Hysteria, **771–772**  
 activity/passivity and, 16  
 actual vs. defense neuroses and, 20  
 alcoholism and, 40  
 "Anna O." case, 87–89, 225, 1223–1224  
 anorexia nervosa and, 91  
 autoplasmic behavior and, 144  
 character and, 271  
 Charcot on, 772, 1529  
 complexes and, 318–319  
 as developmental disorder, 408  
 displacement and, 421  
 "Elisabeth von R." case and, 495–496  
 fantasy and, 550  
 feminist views of psychoanalysis and, 578  
 flight into illness and, 590  
 forgetting and, 596  
 innervation and, 837  
 Janet on, 886  
 Jung on, 1396  
 lies and, 971  
 lifting of amnesia and, 976, 977  
 memory and, 1041–1042, 1043  
 mnemonic symbols and, 1062  
 mnemonic traces and, 1063  
 neuroses and, 287  
 psychic reality and, 1356–1357  
 Régis on, 1459  
 reminiscences and, 1470  
 repression and, 1482  
 reversal into the opposite and, 1495  
 somatic compliance and, 1634–1635  
 splitting and, 1645  
 stammering and, 1653  
 stratification and, 1665  
 subconscious and, 1672  
 subject's desire and, 1678  
 trauma and, 1801  
*See also* Conversion; "Dora" case; Seduction theory
- Hysterical conversion. *See* Conversion
- "Hysterical Fate Neurosis" (Deutsch-Rosenbach), 556–557
- Hysterical paralysis, **773–774**
- "Hysterical Phantasies and their Relation to Bisexuality" (Freud), 551, 839–840
- I**  
**I, 775–776**  
 Aulagnier-Spairani on, 110–111, 130, 142, 775–776, 793, 1119, 1170  
 autohistorization and, 142  
 identificatory project and, 793  
 integration and, 843

Volume 1, pp. 1–662; Volume 2, pp. 663–1344; Volume 3, pp. 1345–1892

- need for causality and, 1119  
 object and, 1170  
*I Ching*, 1720  
*I Never Promised You a Rose Garden* (Greenberg), 652  
 I-persona, 238  
 IAAP. *See* International Association for Analytical Psychology  
*Ich, das*. *See* Ego; Self  
 “Ich als Subjekt und Objekt im Narzissismus, Das” (Federn), 568  
*Ich-Psychologie und Anpassungsproblem* (Hartmann), 727  
*Ich und das Denken, Das* (Hermann), 737  
 Id, **776–780**  
 alpha function and, 51  
 archaic and, 111–112  
 Aulagnier-Spairani on, 110  
 cathexis and, 260  
 contradiction and, 341  
 death instinct and, 371–372  
 ego and, 464, 466, 477  
*Ego and the Id, The* on, 470–471  
 ego autonomy and, 473  
 ethics and, 525  
 identification and, 789  
 object relations theory on, 1177  
 subject of the unconscious and, 1675  
 unconscious and, 1819  
 work of the negative and, 1129  
*See also* Structural theory  
*Id and the Regulatory Principles of Psychoanalysis, The* (Schur), 1549  
 Id psychology, 479  
 Idea/representation. *See* Representation  
 Ideal ego, **481**, 577, 1036, 1037, 1191  
*See also* Ego ideal  
 Ideal object, 545  
 Idealization, **783–784**  
 alcoholism and, 41  
 alienation and, 44  
 anagogical interpretation and, 71  
 animus/anima and, 87  
 borderline conditions and, 202  
 desexualization and, 399  
 ego ideal and, 480  
 family romance and, 548  
 Horney-Danielson on, 759  
 passion and, 1243  
 sublimation and, 1679  
 Idealized parental imago, 52, 184–185, **784**, 1810  
 Idealizing transference, 542, **785**, 1116, 1580  
 Ideational representation, **785–786**, 841, 989  
 Ideational representatives, **786–787**, 841, 1433  
*Idee*. *See* Representation  
 Idées fixes, 385, 1178  
 Identification, **787–791**  
 adolescence and, 26, 29  
 alcoholism and, 41  
 allergies and, 47, 48  
 Althusser on, 53  
*amae* and, 56  
 animistic thought and, 86  
 “as if” personality and, 122  
 asthma and, 124  
 Aulagnier-Spairani on, 110, 111  
 autohistorization and, 142  
 bisexuality and, 187  
 body image and, 197  
 Bornstein on, 205  
 breastfeeding and, 221  
 Burrow on, 237  
 character and, 269, 272  
 conflict and, 326  
 counter-identification and, 348  
 criminology and, 354  
 critical theory and, 31  
 cultural transmission and, 357  
 Death instinct and, 640, 788  
 desexualization and, 399  
 ego and, 462, 464, 465  
 ego ideal and, 480  
 empathy and, 502  
 fatherhood and, 558  
 fetishism and, 583  
 heroic, 738–739, 790  
 hysteria and, 773  
 identificatory project, 790, 793–794  
 identity preservation principle and, 1324  
 imaginary and, 799  
 imaginary/symbolic, 798–799  
 literature and, 985  
 mastery and, 1024  
 melancholia and, 1082, 1083  
 midlife crisis and, 1055  
 mirror stage and, 775, 790, 1107  
 narcissism and, 788, 1105, 1107, 1111  
 need for causality and, 1119  
 object relations theory on, 1177  
 Oedipus complex and, 1185  
 operational thinking and, 1198  
 oral eroticism and, 516  
 perversion and, 1257–1258  
 primary, 788–789, 790, 815  
 projection and, 1336  
 psychological tests and, 1395  
 puerperal psychoses and, 1422  
 superego and, 471, 1691  
 unary trait and, 1814  
 work of the negative and, 1129  
*See also* Identification with the aggressor; Primary Identification; Projective identification  
*Identification* (Lacan), 798, 1761, 1814  
 Identification fantasies, **791–792**  
 Identification with the aggressor, 54, **792–793**, 869, 870  
 Identificatory project, 790, **793–794**  
 Identified patient, 1720  
 “Identité et l’identification chez les adolescents, L” (Kestemberg-Hassin), 911  
 Identity, **794–795**  
 ego and, 481–482, 511, 794  
 identity preservation principle, 1323–1324  
 thought identity, 1748–1749  
*Identity and the Life Cycle* (Erikson), 511  
 Identity preservation principle, **1323–1324**  
*Ideología e Idealización* (Langer), 941  
 Ideology, **795–796**  
 “Ideology and Ideological State Apparatuses” (Althusser), 53  
 IFPS. *See* International Federation of Psychoanalytic Societies  
 Igert, Maurice, 1154  
 Ignotus, Hugo, 580, 765  
 Ikonen, Pentti, 584  
 Ilan, Eliezer, 877  
 “Illness of Mourning and the Fantasy of the Exquisite Corpse, The” (Torok), 850, 1765  
 Illusion, **796–798**, 826  
 “Illusion et la désillusion dans la cure psychanalytique, L” (Favez), 561  
*Illusion of a Future, The* (Pfister), 660, 1260  
*Im Dickicht der Sprache* (Storfer), 1662  
*Image and Appearance of the Human Body, The* (Schilder), 1538  
*Image inconsciente du corps, L’* (Dolto-Marette), 1851  
 Imaginary, the, **799–800**  
 death instinct and, 372  
 ethology and, 528  
 Ferenczi and, 1739  
 knot and, 916–917  
 L and R schemas and, 927  
 Real and, 1453  
 subject and, 1673

## INDEX

Volume 1, pp. 1–662; Volume 2, pp. 663–1344; Volume 3, pp. 1345–1892

- See also* Borromean knot
- Imaginary father, 1452
- Imaginary identification/symbolic identification, **798–799**
- Imagination, 414
- Imago, II:pl.10, **800–801**, 850, 1028, 1664  
*See also* Idealized parental imago
- Imago Publishing Company, 680, **801–802**, 997
- Imago. Zeitschrift für die Anwendung der Psychoanalyse auf die Geisteswissenschaften*, 800, **802–803**
- American Imago* and, 60
- applied psychoanalysis and, 107–108
- Heller and, 732
- Hug-Hellmuth and, 761
- Internationale Zeitschrift für Psychoanalyse* and, 860
- Internationaler Psychoanalytischer Verlag and, 802–803, 861
- Kris and, 924, 1845
- Rank and, 107, 800, 802, 1445
- Sachs and, 1523
- Waelder and, 1845
- Imbasciati, Antonio, 880
- Imbeault, Jean, 245
- “Impatience of Hamlet, The” (Sharpe), 723
- “Imperceptible Obvious, The” (Wilson), 1497
- “Importance of the Unconscious in Psychopathology, The” (Jung), 317
- Imposter, 122, **803**
- Impotence, 342
- Impulse, 143, 1677
- Impulsive actions, phobias of, 1272–1273
- In der Schule bei Freud* (Andreas-Salomé), 83
- Inactuel, L'*, 124
- Inanalysé, L'*, 241
- Incest, **803–804**
- adolescence and, 29
- anti-Semitism and, 1437
- castration complex and, 252, 1676
- compulsion and, 322
- counter-Oedipus and, 349
- fantasy and, 552
- frame of psychoanalytic treatment and, 606, 607
- impotence and, 342
- Jung on, 1400
- Lacan on, 526, 1676
- lies and, 971
- myth of origins and, 1092
- prohibition of, 1332
- sexuation and, 1595
- structural theories and, 1667
- suicide and, 1687
- superego and, 1594, 1690, 1691
- symbolic and, 1710
- wish for a baby and, 1864  
*See also* Myth of origins
- Inceste et l'incestuel, L'* (Racamier), 1436
- Incompleteness, **804–806**
- Inconscient, L'*, 129–130, 528–529, 611, **806–807**, 1835
- Inconscient des modernes, L'* (Vaysse), 1271
- “Inconscient et la défense psychologique de l'individu” (Morichau-Beauchant), 196, 1075
- Inconscient et Réalité* (Dayan), 848
- Incorporation
- Abraham, Karl on, 1105
- Abraham, Nicolas on, 7
- allergies and, 48
- dependence and, 392
- identification and, 787
- internal objects and, 849
- introjection and, 869
- melancholia and, 1038
- narcissism and, 1105
- oral-sadistic stage and, 1203
- orality and, 1202
- secrets and, 1560
- sucking and, 1682
- Torok on, 1765
- on ulcerative colitis, 1814
- “vagina dentata” fantasy and, 1831
- Independent Group. *See* British Psycho-Analytical Society
- Index Psycho-Analyticus* (Rickman), 1502
- Indian psychoanalysis, 206, **807–808**
- Indian Psychoanalytic Society, 206, 807, 808
- Indications/contraindications for psychoanalysis, **808–810**
- Individual, 467, **810–811**
- Individual and His Society, The* (Kardiner), 906, 907
- “Individual and Mass Behavior in Extreme Situations” (Bettelheim), 172
- Individual psychology, 25–26  
*See also* Adler, Alfred
- Individuation, **811–812**
- adolescence and, 27
- Blos on, 197
- identity and, 794
- individual and, 811
- infant development and, 814–815
- Mahler-Schönberger on, 1002
- paranoia and, 1228
- self and, 1581
- self-consciousness and, 1569–1570
- Shakespeare and, 1598
- transference and, 1779
- true/false self and, 1582
- weaning and, 1852
- Inequality of Human Races, The* (Gobineau), 1437
- Inertia principle, 1322–1323, **1324–1325**
- Infancy
- adolescence and, 28, 29
- amae* and, 56
- amnesia and, 65
- autism in, 71, 136
- dependence and, 392
- early interactions and, 453–454
- helplessness and, 734, 814
- projective identification in, 51  
*See also* *Infans* stage; Infant development; Infant observation; Infantile sexuality; Mother-infant bond
- Infans* stage, **812–814**
- Infant development, **814–816**  
*See also* Infantile sexuality; Libidinal development
- Infant observation, 281, 815, **816–819**
- adhesive identification and, 24
- Bick on, 177, 178, 816, 817, 818–819
- developmental processes and, 1330
- “Infant Observation: Its Relevance to Psychoanalytic Training” (Freud), 818
- Infante, José Antonio, 284, 285
- Infanticide, 39
- Infantile, the, **830–831**
- Infantile amnesia, 64, 592, **819–820**
- Infantile anxiety, 1646
- Infantile creativity, 190
- Infantile depression, 70–71, 236, 368–369
- “Infantile Genital Organization, The” (Freud)
- on castration complex, 252
- on disavowal, 415–416
- on female sexuality, 365
- on genital stage, 672
- on Oedipus complex, 1184–1185
- on organization, 1208
- on pregenital organization, 1301–1302
- Infantile neurosis, 75–76, **820–822**, 1140
- Infantile omnipotence, **822–823**, 1106, 1189
- Infantile psychosis, **823–827**, 827–828
- Infantile schizophrenia, 823, **827–828**

Volume 1, pp. 1–662; Volume 2, pp. 663–1344; Volume 3, pp. 1345–1892

- Infantile sexual curiosity, **829–830**, 1093, 1195, 1262, 1590
- Infantile sexuality, 1405–1407, 1593, 1752–1755
- activity/passivity and, 17
- anaclisis and, 69
- autoeroticism and, 141
- biological bedrock and, 182
- breastfeeding and, 221
- childhood and, 280
- constitution and, 334
- controversy about, 1751–1752
- criticisms of psychoanalysis and, 639
- curiosity and, 829, 1093, 1195, 1262, 1590
- deferred action and, 380
- drives and, 445
- Eckstein on, 455
- Eros and, 512
- erotogenic zones and, 519, 520
- exhibitionism and, 535
- feces and, 564
- fixation and, 588
- Freud-Jung split and, 1192
- infantile amnesia and, 819, 820
- infantile and, 830
- “Little Hans” case and, 75
- masturbation and, 1026–1027
- ontogenesis and, 1197
- organ pleasure and, 1206
- orgasm and, 1209
- partial drives and, 1240
- pleasure ego/reality ego and, 1288
- primary object and, 1753–1754
- seduction and, 221
- seduction scenes and, 1565–1566
- seduction theory and, 1564, 1592
- sexual drives and, 1589
- superego and, 1690
- Weininger on, 1588
- “Wolf Man” case and, 649
- See also* Libidinal development
- Infants Without Families* (Anna Freud and Burlingham-Tiffany), 236, 619
- Infatuation, 994
- Inferiority feelings, 323, 550, **831–832**, 1246
- “Influence of Oral Erotism on Character Formation, The” (Abraham), 1202
- Influencing machines, 1193–1194
- Informed Heart, The; Autonomy in a Mass Age* (Bettelheim), 172, 173
- Inhibition, **832–833**
- friendship and, 646, 647
- jokes and, 890
- knowledge instinct and, 918
- orgasm and, 1209, 1210
- sublimation and, 1679
- symptoms and, 1715
- thought and, 1747–1748
- Inhibitions, Symptoms, and Anxiety* (Freud), **833–834**
- on abandonment, 2
- on anticathexes, 94
- on anxiety, 99, 100, 101, 102, 1137, 1604
- on automatism, 143
- on castration complex, 251, 253, 254
- on cathexis, 260
- on change, 267
- collective psychology and, 311
- on Darwinism, 366
- on defense mechanisms, 377
- on defenses, 375
- on derivatives of the repressed, 1481
- on ego, 466
- ego psychology and, 486
- on erotogenicity and, 521
- on fear, 563
- on helplessness, 1439
- on inhibition, 832
- on isolation, 876
- on libido, 969
- on object loss, 994
- on obsessional neurosis, 1180
- on pain, 1219
- on phobias, 1276
- on protective shield, 1340
- publication of, 641, 833
- Rank and, 1803
- on representation, 782
- on repression, 1480
- on resistance, 1489
- on rituals, 1504–1505
- on scotomization, 1554
- on substitute formations, 1680, 1681
- on symptom-formation, 1716
- on undoing, 1822
- Inhibitory id, 495
- Initial interview, **834–836**
- “Inner World in Ibsen’s ‘Master-Builder’, The” (Riviere-Hodgson Verrall), 1507–1508
- Innervation, **836**
- Innocence of Dreams, The* (Rycroft), 1521
- Inside/outside. *See* Internal/external reality
- Insight, **836–837**, 871
- Insight and Responsibility* (Erikson), 511
- Instinct theory
- Adorno and, 31
- dualism and, 449, 659
- erotogenicity and, 521
- sexualization and, 398, 399
- See also* Death instinct; Life instinct
- Instincts, **837–838**
- actual vs. defense neuroses and, 20
- alcoholism and, 41
- amae* and, 56
- anaclisis and, 69
- anaclitic depression and, 70
- anthropology and, 93
- anxiety and, 99
- archetypes and, 115
- binding/unbinding of, 179–180
- Chinese psychoanalysis and, 286
- ideational representative and, 786
- impulse and, 839–840
- incompleteness and, 805
- mastery and, 917, 1025
- psychogenic blindness and, 1392
- See also* Death instinct (Thanatos); Drives; Life instinct (Eros)
- “Instincts and Their Vicissitudes” (Freud), **838–839**
- on activity/passivity, 16, 17
- on adaptation, 22
- on binding/unbinding, 179
- on death instinct, 371
- on drives, 446, 838, 1674
- on fantasy, 552
- on hatred, 728–729
- on instinctual impulse, 840
- on introjection, 869
- on love, 995
- on masochism, 1021, 1315
- on mastery, 1025
- on narcissism, 1105
- on object, 1168
- on organ pleasure, 1206
- on primary need, 1316
- on projection, 1335
- on psychic representative, 1358
- on psychosomatic limit, 1410
- on purified-pleasure-ego, 1423
- on quantitative/qualitative dimensions, 1428
- on reaction-formations, 1449
- on reversal into the opposite, 1495
- on sadism, 355, 1525–1526
- on sadomasochism, 1527

## INDEX

Volume 1, pp. 1–662; Volume 2, pp. 663–1344; Volume 3, pp. 1345–1892

- on self, 1579  
 on self-preservation, 1575  
 on splitting, 1287  
 on subject of the unconscious, 1675  
 on turning around, 1495, 1806, 1807  
 on violence instinct, 1838  
 on voyeurism, 1843  
 on working over, 1878  
 Instinctual impulse, **839–840**  
 Instinctual representative, 786, **841**, 1358  
 Institut Claparède, **841–842**  
 Institut de psychanalyse de Paris, 608, 609, **1623–1631**  
 CCTP and, 264  
 Diatkine and, 410–411  
 Favez-Boutonier and, 560  
 Held and, 731  
 Lebovici and, 955  
 Mâle and, 1004  
 Nacht and, 609, 955, 1004  
 Racamier and, 1435  
 Institut de psychosomatique (IPSO), 610, 611, 1016  
 Institut für psychogene Erkrankungen, 165  
 Institut für Sozialforschung. *See* Institute for Social Research  
 Institut Jean-Jacques Rousseau, 302, 1544, 1556  
 Institut Max-Kassowitz, **842–843**  
 Institute for Psychopathology and Psychotherapy, 1547  
 Institute for Social Research, 1013, 1044, 1602  
 Institute of Psychoanalysis and Psychotherapy, 1292  
 Institute of the Freudian Field, 1519  
 Instituto brasileiro de psicanálise, 214  
 Insurance, 679, 1069  
 Integration, **843–844**  
 Intellect. *See* Pleasure in thinking  
*Intellectual Growth in Young Children* (Isaacs), 873  
 Intellectualization, 67–68, **844–845**, 862, 1448  
 Intensity, 324–325  
 Intentionality, 1478, 1482, 1486  
 Interactions of psychoanalysis. *See* Multidisciplinary interactions  
 Interassociatif européen de psychanalyse, 1084  
 Intergenerational phenomena, 357–358, 791, **845–847**  
 Internal/external reality, **847–849**  
 adolescence and, 29, 30  
 Adorno on, 31  
 alcoholism and, 41  
 danger and, 364  
 ego boundaries and, 474  
 fantasy and, 1451  
 historical reality and, 748–749  
 Isakower phenomenon and, 875  
 “Metapsychological Supplement to the Theory of Dreams, A” on, 1048  
 projection and, 1334, 1335–1336  
 psychic reality and, 1357  
 reality testing and, 1450–1451  
 skin-ego and, 1613  
 transitional phenomena and, 1794, 1795  
 Internal objects, **849–851**, 1171  
 blank psychoses and, 191  
 borderline conditions and, 202  
 concepts and, 323–324  
 depressive position and, 395–396  
 emotions and, 501  
 introjection and, 870  
 Klein on, 219, 395–396  
 maternal and, 1027  
 object relations theory on, 1176  
 paranoid position and, 1231  
 paranoid-schizoid position and, 1233  
 pregnancy fantasy and, 1302  
 splitting of, 1642  
 transference displacement and, 423  
 trauma and, 1801  
 Internal saboteur. *See* Antilibidinal ego  
 Internalization. *See* Externalization-internalization  
 International Association for Analytic Psychology, 217  
 International Association for Analytical Psychology (IAAP), 80  
 International Association of the History of Psychoanalysis (Association Internationale d’histoire de la psychanalyse), 507, 613, **851–852**  
*International Classification of Diseases* (WHO), 828, 1138, 1276  
 International Federation of Psychoanalytic Societies (IFPS), 677, **852–853**, 1131  
 Brazilian psychoanalysis and, 217  
 International Federation of Working Groups on Depth Psychology, 134  
*International Forum of Psychoanalysis*, 852–853  
*International Journal of Offender Therapy and Comparative Criminology, The*, 1543  
*International Journal of Psychoanalysis, The*, 229, 698, **853–854**  
 on analysand, 75  
 Brierley and, 226  
 Flügel and, 593  
 Hartmann and, 727  
*Internationale Zeitschrift für Psychoanalyse* and, 860, 861  
 Internationaler Psychoanalytischer Verlag and, 861  
 Jones and, 698, 853, 860, 893  
 Khan and, 913  
 Riviere-Hodgson Verrall and, 229, 593, 1507  
 Sandler and, 853, 1533  
 on *Secrets of a Soul, The*, 1563  
 International Psychoanalytic Press. *See* Internationaler Psychoanalytischer Verlag  
 International Psychoanalytical Association (IPA), **854–860**  
 Abraham presidency, 5  
 Adler founding, 25  
 American Psychoanalytic Association and, 227–228, 856, 857, 858–859, 1531, 1644, 1824, 1825–1826  
 Argentinian psychoanalysis and, 117, 118, 241, 248  
 Association psychanalytique de France and, 122, 123  
 Australian psychoanalysis and, 131–132  
 Austrian psychoanalysis and, 132, 133, 134, 135–136, 1858  
 Belgian psychoanalysis and, 157  
 Berge and, 162  
 Berliner Psychoanalytisches Institut and, 166  
 Brazilian psychoanalysis and, 214, 216, 858, 955, 1012  
 British Psycho-Analytical Society and, 230  
 Canadian psychoanalysis and, 241, 242, 243  
 Chilean psychoanalysis and, 284  
 Chinese psychoanalysis and, 287  
 Colombian psychoanalysis and, 315  
*Confrontation* and, 327  
 Congrès des psychanalystes de langue française des pays romans and, 330  
 Czech psychoanalysis and, 361  
 Danish psychoanalysis and, 390–391  
 Deutsche psychoanalytische Vereinigung and, 1085  
 Dolto-Marette and, 162, 327  
 Dutch psychoanalysis and, 1132–1133, 1200  
 Eissler-Selke and, 492  
 Eitingon and, 492

Volume 1, pp. 1–662; Volume 2, pp. 663–1344; Volume 3, pp. 1345–1892

- European Psychoanalytical Federation and, 529, 530
- Federación psicoanalítica de América latina and, 565, 566, 567
- Fédida and, 569
- Ferenczi and, 580
- Finnish psychoanalysis and, 584
- Flügel and, 593
- founding of, 61, 580
- French psychoanalysis and, 608, 609, 610, 613
- French psychoanalytic establishment split (1953) and, 609, 1251
- French psychoanalytic establishment split (1964) and, 610–611, 957
- Fromm and, 651
- Gaddini and, 663
- Garma and, 665
- German psychoanalysis and, 674, 675, 677, 856, 1060
- Greek psychoanalysis and, 701
- Hartmann and, 728
- Hesnard and, 742
- Hungarian psychoanalysis and, 765, 766
- Indian psychoanalysis and, 807
- International Federation of Psychoanalytic Societies and, 852
- International Journal of Psychoanalysis, The* and, 853
- Internationale Zeitschrift für Psychoanalyse* and, 860
- Internationaler Psychoanalytischer Verlag and, 861, 862
- Israeli psychoanalysis and, 876, 877
- Italian psychoanalysis and, 879, 881, 1854
- Japanese psychoanalysis and, 888
- Jones and, 893
- Jung and, 79, 854, 902
- Kemper, Werner Walther and, 910
- Kohut and, 919
- Korean psychoanalysis and, 921
- Lampl-de Groot and, 938
- lay analysis and, 639, 854–855, 857, 858–859
- Lebovici and, 955
- Leclair and, 957
- Limentani and, 858, 978
- Loewenstein and, 988, 989
- Los Angeles Psychoanalytic Society/Institute and, 993
- Mexican psychoanalysis and, 1051
- Nacht and, 1102
- New York Freudian Society and, 1146–1147
- North African psychoanalysis and, 1155
- Norwegian psychoanalysis and, 1157
- “On the History of the Psychoanalytic Movement” on, 1192
- Peruvian psychoanalysis and, 1254
- Polish psychoanalysis and, 1292
- Portuguese psychoanalysis and, 1296
- psychoanalytic filiations and, 1373
- psychoanalytic treatment and, 1729
- Rank and, 854, 1445
- Reich, Annie and, 1461
- Reich, Wilhelm and, 1462
- Revista de psicoanálisis* and, 1496
- Russian/Soviet psychoanalysis and, 1518, 1519, 1520
- Sandler and, 1533
- Saussure, Raymond de and, 1536
- Secret Committee and, 854, 1561, 1562
- Servadio and, 1586
- Smirmoff and, 1617
- Société française de psychanalyse and, 560, 692, 1251, 1619
- Société psychanalytique de Paris and, 1624, 1630
- Spanish psychoanalysis and, 1637
- Standard Edition* and, 1558, 1663
- supervised analysis and, 1692
- Swedish psychoanalysis and, 1698
- Swiss psychoanalysis and, 1549, 1620, 1700, 1701, 1702
- training analysis and, 1769, 1770
- Uruguayan psychoanalysis and, 1829
- U.S. psychoanalysis and, 1558
- Venezuelan psychoanalysis and, 1832
- Wiener psychoanalytische Vereinigung and, 1857
- Zentralblatt für Psychoanalyse* and, 1887
- Zetzel-Rosenberg and, 1888
- See also* French psychoanalytic establishment split (1964)
- International Review of Psychoanalysis*, 1533
- International Sociological Association, 1632
- International Training Commission (ITC), 855–856
- International Working Group of Psychoanalytic Societies, 134
- Internationale Ärztliche Gesellschaft für Psychotherapie, 49
- Internationale Föderation psychoanalytischer Gesellschaften. *See* International Federation of Psychoanalytic Societies
- Internationale Zeitschrift für ärztliche Psychoanalyse. See* *Internationale Zeitschrift für Psychoanalyse*
- Internationale Zeitschrift für Individualpsychologie*, 25
- Internationale Zeitschrift für Psychoanalyse*, II:pl.11,12, 732, 761, **860–861**
- Abraham and, 5
- Burrow and, 238
- Federn, Paul and, 568
- German psychoanalysis and, 675
- Imago* and, 803
- Internationaler Psychoanalytischer Verlag and, 860, 861
- Marcinowski and, 1011
- Radó and, 860, 1441
- Rank and, 1445
- on *Secrets of a Soul, The*, 1563
- Internationaler Psychoanalytischer Verlag, 732, **861–862**
- Almanach der Psychoanalyse* and, 49–50
- German psychoanalysis and, 675
- Gesammelte Schriften* and, 680
- Imago* and, 802–803, 861
- Internationale Zeitschrift für Psychoanalyse* and, 860, 861
- Jones and, 893
- Rank and, 49, 861, 1445
- Storfer and, 1661
- Van Ophuijsen and, 1200
- Interpersonal analysis, 577, 759, 1688, 1746
- Interpersonal Psychoanalysis: The Selected Papers of Clara Thompson* (Thompson), 1746
- Interprétation*, 178
- Interpretation, **862–864**
- Interprétation*, 864, **864**, 1247
- Interpretation
- amplification and, 68
- anagogical, 71
- analytic psychodrama and, 77–78
- analyzability and, 81
- autobiography and, 140
- Bernfeld on, 169
- Bouvet on, 210
- child analysis and, 1733
- lifting of amnesia and, 977
- negation and, 1122
- over-interpretation, 1217
- vertex and, 1833–1834
- Interpretation of dreams. *See* Dream interpretation
- Interpretation of Dreams, The* (Freud), **866–867**
- action-presentations and, 12
- on adolescence, 28



## INDEX

Volume 1, pp. 1–662; Volume 2, pp. 663–1344; Volume 3, pp. 1345–1892

- on agency, 32, 33
- on amnesia, 64
- on anthropology, 93
- on anticathexes, 94
- on anxiety, 969
- on anxiety dreams, 103
- on attention, 127
- on Bernays-Freud, Minna, 168
- on biological bedrock, 182
- on birth, 185–186
- on breastfeeding, 220
- on castration complex, 251
- on cathectic energy, 259
- on censorship, 262
- on character, 269, 272
- cinema and, 293
- cognitivism and, 309
- on condensation, 324, 325
- on consciousness, 333, 1567
- on constancy principle, 1323
- on contradiction, 341
- on daydreams, 555, 1493
- on day's residues, 367
- on death, 370
- on deferred action, 378
- Delboeuf and, 384
- Delusions and Dreams in Jensen's "Grädiva"* and, 387
- on determinism, 401
- Deuticke and, 403
- on displacement, 421
- on dream symbolism, 441
- on dream work, 442
- on dreams, 436–437, 438
- on dream's navel, 443, 1453
- on dreams of convenience, 344
- on dreams of mourning, 1083
- on ego, 462
- on ego interests, 484
- ego psychology and, 486
- on Eros, 512
- on evenly-suspended attention, 530–531
- on examination dreams, 533
- on excitation, 533
- on experience of satisfaction, 536
- on facilitation, 543
- on fantasy, 550, 551
- on fatherhood, 558
- on fear, 563
- Federn, Paul and, 568
- on free association, 1384
- on free energy/bound energy, 617
- on Freud, Jakob Kolloman, 624
- on Freud, Josef, 623, 627
- on Freud's secondary schooling, 1836
- Freud's self-analysis and, 643
- Gesammelte Schriften* and, 680
- Gesammelte Werke* and, 681
- on hallucinatory wish-fulfillment, 1866
- on hypercathexis, 767
- on hypocritical dreams, 771
- on identification, 787
- on incompleteness, 805
- on infant development, 814
- on infantile amnesia, 820
- on infantile psychosis, 825–826
- on inferiority feelings, 831
- on internal/external reality, 847–848
- on "Irma's injection" dream, 628, 872–873, 1032, 1216, 1453, 1502
- Jokes and their Relation to the Unconscious* and, 891
- Jung and, 864–865
- on language, 440, 942
- on latent/manifest dream elements, 947, 1007
- on logic, 989–990
- on masochism, 1021
- Matte-Blanco on, 1033
- on memory, 1042
- Meyerson and, 1053–1054
- on mnemic traces, 1063–1065
- on mourning, 1081
- on mysticism, 1091
- on nakedness dreams, 1103
- on need for punishment, 1120
- on neurotic defenses, 1142
- New Introductory Lectures on Psychoanalysis* on, 1145
- on nightmares, 1149
- on Nirvana principle, 1151
- on Oedipus complex, 1184
- "On Dreams" and, 1190
- on optical schema, 1201
- on over-interpretation, 1217
- on overdetermination, 1216
- on partial drives, 1240
- on perceptual identity, 1249
- philosophy and, 1271
- on pictogram, 1285
- on pleasure in thinking, 1289
- on pleasure principle, 1290, 1325
- on politics, 1293
- Politzer and, 1294
- on prehistory, 1303
- on premonitory dreams, 1305
- on primal, 1312
- on primal scene, 1310
- on primary need, 1316
- on primary/secondary processes, 1328
- on primitive words, 3
- on psi system, 1345
- on psyche, 1348, 1349
- on psychic apparatus, 1351, 1379
- on psychic causality, 1353–1354
- on psychic energy, 1355
- on psychic reality, 1356
- on psychology and psychoanalysis, 1397
- publication of, 638, 866
- on punishment dreams, 1422
- on purposive idea, 1424
- on quantitative/qualitative dimensions, 1428
- Real and, 1453
- on regression, 1459
- on repetition, 1473
- on representability, 1477
- on repression, 1479, 1485, 1491
- on rescue fantasies, 1488
- on reversal into the opposite, 1494, 1495
- on scientific nature of psychoanalysis, 1551
- on secondary revision, 1558–1559
- on secrets, 1560
- on self-consciousness, 1570
- on self-punishment, 1577
- on sense/nonsense, 1584
- on sexuality, 1593
- on sleep/wakefulness, 1614
- Stekel and, 1657
- on stratification, 1665
- structural theories and, 1666
- on subject of the unconscious, 1675
- on sudden involuntary ideas, 1683
- surrealism and, 1695
- on symbolization, 442
- on thought, 1746, 1747
- on thought identity, 1749
- on time, 1757
- on transgression, 1791
- Trauma of Birth, The* and, 1802
- on typical dreams, 1810–1811
- on unconscious, 1819
- on unpleasure, 1826–1827
- on visual, 1840
- on wish-fulfillment, 1864, 1865
- on wishes, 1867
- on work, 1875–1876

Volume 1, pp. 1–662; Volume 2, pp. 663–1344; Volume 3, pp. 1345–1892

- Interpretation of Dreams, The* (Stekel), 1657  
*Interpretation of Schizophrenia, The* (Arieti), 1541  
*Interprète un quête de sens* (Aulagnier-Spairani), 130  
 Interrelations. *See* Early interactions  
 Intersubjective/intrasubjective dichotomy, **867–868**  
 Intersubjectivity, 546, 821, 867–868, 1307, 1827  
 Intervention, 863  
*Introduction à la théorie des instincts* (Bonaparte), 200  
 “Introduction à l’étude du transfert en clinique psychanalytique” (Schlumberger), 1542  
 “Introduction à une discussion sur le concept d’objet en psychanalyse” (Diatkine), 411  
*Introduction to the Psychoanalytic Theory of the Libido* (Sterba), 1659  
*Introductory Lectures on Psychoanalysis* (Freud), **868–869**  
 on anticipatory ideas, 95  
 on anxiety, 563  
 on anxiety dreams, 103  
 on birth, 185  
 on change, 267  
 on choice of neurosis, 288  
 on complementary series, 318  
 on constitution, 335  
 on day’s residues, 368  
 on definition of psychoanalysis, 1364  
 on disavowal, 415  
 on ego, 463  
 on ego interests, 484  
 First World War and, 586  
*Five Lectures on Psycho-Analysis* (Clark University) and, 207, 302–303, 868  
 on gain, 664  
 on internal/external reality, 847  
 Jankélévitch and, 887  
 on latent dream thoughts, 947, 948  
 on lifting of repression, 1486  
 music and, 1088  
 on ontogenesis, 1197  
 on organ pleasure, 1206  
 on organization, 1208  
 on paraphrenia, 1234  
 on parapraxes, 1235  
 on primal, 1312  
 on primal fantasies, 1307  
 publication of, 732  
 on punishment dreams, 1422  
 on regression, 1460  
 on resistance, 1489  
 on reversal into the opposite, 1495  
 on rituals, 1504  
 on separation, 995  
 on sexuality, 1593  
 on slips of the tongue, 1615  
 on suggestion, 1685  
 on termination of treatment, 1737  
 on traumatic neuroses, 1804  
 on weaning, 1851  
**Introjection, 869–870**  
 Abraham, Karl on, 6, 869  
 anality and, 72  
 anxiety and, 100  
 archaic mother and, 113  
 breast as good/bad object and, 219  
 coprophilia and, 346  
 criminology and, 354  
 depersonalization and, 393  
 depressive position and, 396  
 disintegration anxieties and, 418  
 ego and, 465  
 female sexuality and, 577  
 Ferenczi on, 7, 328, 581, 869, 870–871, 1105, 1336  
*Fort-da* game and, 600  
 heroic self and, 739–740  
 identification and, 789  
 identification fantasies and, 791  
 imago and, 801  
 infantile psychosis and, 826  
 internal objects and, 849, 850  
 libido and, 6  
 narcissism and, 1105  
 oral stage and, 1205  
 paranoid-schizoid position and, 1233  
 pictogram and, 1286  
 projection and, 1336  
 projective identification and, 1338  
 self and, 1579  
 self-punishment and, 1577  
 splitting of the object and, 1642  
 Torok on, 1765  
 trauma and, 7  
 “Introjection and Transference” (Ferenczi), 580, 869, **870–871**, 1106  
**Introspection, 871**  
 Introversión. *See* Extroversión/introversión  
**Invariant, 871–872**  
*Invasion of Compulsory Sexual Morality, The* (Reich), 1461  
*Investigation psychosomatique, L’* (Marty, M’Uzan and David), 1016, 1198, 1407  
*Io legato e la Libertà, L’* (Perrotti), 1252  
 IPA. *See* International Psychoanalytical Association  
 IPSO (Institut de psychosomatique), 610, 611, 1016  
 Irigaray, Luce, 327, 365, 578, 1247  
 “Irma’s injection” dream, **872–873**  
 femininity and, 573  
 Mathilde case and, 1032  
 overdetermination and, 1216  
 Real and, 1453  
 Rie and, 1502  
 Schur on, 628  
 wish-fulfillment and, 1864  
 Irony, 1584–1585  
 Isaacs-Sutherland, Susan, **873–874**  
 Argentinian psychoanalysis and, 118  
 British Psycho-Analytical Society and, 229, 343, 344  
 British psychoanalysis and, 697  
 Controversial Discussions and, 343, 344, 697, 873–874  
 on defense mechanisms, 377  
 on fantasy, 552  
 Glover, James and, 685  
 Hellman Noach and, 733  
 on imago, 801  
 on paranoid position, 1231  
*Psychanalyse, La* and, 1348  
 Riviere-Hodgson Verrall and, 873, 1507  
 Tavistock Clinic and, 1728  
 Tustin and, 1809  
 on unconscious fantasies, 1817  
 Zetzel-Rosenberg and, 1887  
 Isakower, Otto, 680, **874**, 959, 1148  
 Isakower phenomenon, 440, 441, **874–875**  
 Isay, R. A., 757  
 Islam, 1156  
 Islas, J., 1052  
 Isolation, **875–876**, 1141–1142, 1180  
 Israël, Lucien, 807, 957  
 Israël, Paul, 1628, 1630, 1630–1631  
 Israeli psychoanalysis, 461, **876–878**, 1881  
 Israeli Psychoanalytic Society, 876, 877–878  
 Israëls, Hans, 1546  
 Isserlin, Max, 940  
 It, 201  
 Italian psychoanalysis, **878–881**  
 Fornari and, 598  
 Levi Bianchini and, 963  
 Musatti and, 878, 880, 881, 1088, 1800

## INDEX

Volume 1, pp. 1–662; Volume 2, pp. 663–1344; Volume 3, pp. 1345–1892

- Opere* and, 1198  
 pass and, 1243  
 Perrotti and, 878, 879, 881, 1251, 1854  
 Tomasi and, 879, 1758  
 Weiss and, 495, 878, 879, 963, 1508, 1853  
 Italian Psychoanalytic Society. *See* Società Psicoanalitica Italiana  
 ITC. *See* International Training Commission
- J**
- Jabès, Edmond, 1628  
 Jaccard, Roland, 732  
 Jackson, Don D., 433  
 Jackson, Edith, 619, 626  
 Jackson, John Hughlings  
 British psychoanalysis and, 695, 696  
 on epilepsy, 143  
 Ey and, 539  
 Meyer and, 1052, 1053  
 on ontogenesis, 1197  
 on organodynamic current, 1392  
 on phylogenesis, 1277  
 Jacobson, Edith, **883–884**  
 Bak and, 147  
 Canadian psychoanalysis and, 242  
 on ego boundaries, 474  
 on identification, 790  
 on identity, 795  
*Journal of the American Psychoanalytic Association*, 897  
 Mahler-Schönberger and, 1001  
 Nazi Germany and, 676, 883  
 New York Psychoanalytic Institute/Society and, 1148  
 object relations theory and, 1176  
 photograph of, II:pl.13  
 on primary identification, 1314  
*Psyche* and, 1351  
*Psychoanalytic Study of the Child, The* and, 1382  
 on self, 1567  
 on self-representation, 1578  
 Zetzel-Rosenberg and, 1888  
 Jacoby, Russell, 60  
 Jaffe, Ruth, 876, 877  
 Jager, Karl, 743  
*Jahrbuch der Psychoanalyse*, 679, 884, 1887  
*Jahrbuch für psychoanalytische und psychopathologische Forschungen*, 5, 403  
 Jakobson, Roman  
 on contact, 339  
 formations of the unconscious and, 598  
 linguistics and, 982, 986  
 on phallus, 1264  
 on signifiers, 1604  
 structural theories and, 1667  
 structuralism and, 1668  
*Jalousie amoureuse, La* (Lagache), **884–885**, 936  
 Jaloux, Edmond, 423–424, 1350  
 James, Colin, 391  
 James, Henry, 908  
 James, William  
 Flournoy, Théodore and, 592  
 Freud U.S. visit and, 303  
 Hall and, 720  
 Murray and, 1087  
 Putnam and, 1424  
 on self, 1567  
 U.S. psychoanalysis and, 1822  
 Janet, Pierre, **885–886**  
 “Anna O.” case and, 89, 225  
 on automatism, 143  
 on autosuggestion, 144  
 British psychoanalysis and, 695  
 “Cécilie M.” case and, 240  
 case histories and, 250  
 cathartic method and, 225  
 Charcot and, 274, 275  
 on claustrophobia, 306  
 on compulsion, 322  
 on conflict, 325  
 on déjà vu, 381  
 Delay and, 383  
 Desoille and, 400  
 Ellenberger on, 497  
 on estrangement, 524  
 French psychoanalysis and, 607  
 on hypnosis, 769  
 on intellectualization, 844  
 Jung and, 901  
 Lacan and, 37  
 Mâle and, 1004  
 on memory, 1043  
 Meyerson and, 1053, 1054  
 on mythomania, 1098  
 “Neuro-Psychoses of Defense, The” and, 1671  
 on neuroses, 287  
 on obsessions, 1178  
 on ontogenesis, 1197  
 on phobias, 1272, 1273  
 Piaget and, 1282  
 Pichon and, 886, 1283  
 on primary/secondary processes, 1318  
*Psychanalyse des névroses et des psychoses, La* and, 1361  
*Psyché* and, 1350  
 psychology and psychoanalysis and, 1397  
 on psychosis/neurosis distinction, 1414  
 Salpêtrière Hospital and, 1529  
 Sokolnicka-Kutner and, 1633  
 on splitting, 1646  
 on subconscious, 1672, 1673  
 on suggestion, 1685  
 Swedish psychoanalysis and, 1697  
 U.S. psychoanalysis and, 1822  
 Janin, C., 1500  
 Jankélévitch, Samuel, **886–887**, 1634  
*JAPA (Journal of the American Psychoanalytic Association)*, **897–898**, 1548  
 Japan Psychoanalytic Society, 887, 888, 922  
 Japanese psychoanalysis, 887, **887–888**, 888, 920, 921–922  
 Jaques, Elliott, 1055, 1632  
 Jaspers, Karl  
 Delgado and, 385  
 on delusions, 386  
*Évolution psychiatrique, L’* and, 532  
 Lacan and, 37  
 on nostalgia, 1158  
 on phenomenology, 1267  
 on process, 1327  
*Psyché* and, 1350  
 “Je sais bien mais quand même” (Mannoni), 1010  
 Jealousy  
 Lagache on, 884–885, 1230  
 orality and, 1202  
 otherness and, 1214  
 paranoia and, 1230  
 “Jealousy as a Mechanism of Defence” (Riviere-Hodgson Verrall), 1507  
 Jeammet, Philippe, 27, 392, 911, 1686  
 Jeammet, Phillipe, 234  
 Jeanneau, Augustin, 331, 722, 1627, 1628  
 Jeddi, Essedik, 1155, 1156  
 Jekels, Ludwig, **888–889**  
 Bergler and, 163  
 photograph of, II:pl.14  
 Polish psychoanalysis and, 888, 1291  
*Rivista di psicoanalisi* and, 1508  
 on Shakespeare, 1597  
 Swedish psychoanalysis and, 1698  
 Tegel clinic and, 1734  
 Vienna Ambulatorium and, 959

Volume 1, pp. 1–662; Volume 2, pp. 663–1344; Volume 3, pp. 1345–1892

- Wiener psychoanalytische Vereinigung and, 1858
- Jelliffe, Smith Ely, **889–890**  
 photograph of, II:pl.15  
*Psychoanalytic Review, The* and, 1379  
 U.S. psychoanalysis and, 1822
- Jellinek, Edmund, 413
- Jensen, Wilhelm, 103, 107, 108
- Jensen, William, *See also Delusions and Dreams in Jensen's "Gradiva"* (Freud)
- Jessner, Lucie, 207
- Jewish Family Service, 1658
- Jiménez, Juan Pablo, 285
- Jocasta complex, 319
- Jodl, Friedrich, 1852
- Joffe, Walter, 508
- John of the Cross, St., 895
- Johnson, Alvin, 1869
- Jokes, 325, **890–891**, 891–892, 1584–1585  
*See also Humor*
- Jokes and their Relation to the Unconscious* (Freud), 890, **891–892**  
 applied psychoanalysis and, 107  
 collective psychology and, 311  
 on empathy, 502  
 on humor, 762  
 on introjection, 871  
 on pleasure principle, 1291  
 publication of, 638  
 on repetition, 1473  
 on sense/nonsense, 1585  
 on work, 1876
- Jokipaltio, Leena-Maija, 584
- Jokl, Robert Hans, 959, 1659, 1845
- Jones, Ernest, **892–894**  
 on *American Imago*, 801  
 American Psychoanalytic Association and, 61, 227, 237  
 on anagogical interpretation, 71  
 on anal eroticism, 515  
 on “Anna O.” case, 87, 89, 225, 1223, 1224  
 on aphanisis, 90, 105, 1264  
 Argentinian psychoanalysis and, 117  
 Australian psychoanalysis and, 130, 131  
 Belgian psychoanalysis and, 157  
 Berggasse 19, Wien IX and, 162  
 Bernays, Eli and, 634  
 on *Beyond the Pleasure Principle*, 174–175  
 on birth dreams, 186  
 Blanton and, 193  
 Boston Psychoanalytic Society/Institute and, 206–207  
 boundary violations and, 209  
 Brazilian psychoanalysis and, 919  
 British Psycho-Analytical Society and, 228, 229, 230  
 British psychoanalysis and, 695–696, 697  
 Canadian psychoanalysis and, 241, 242  
 on cocaine, 308  
 Congrès des psychanalystes de langue française des pays romans and, 330  
 Controversial Discussions and, 343, 344  
 Danish psychoanalysis and, 390  
 Delgado and, 385  
*Development of Psycho-Analysis* and, 581  
 on “Dora” case, 604  
 Eder and, 460  
 Emden and, 498  
 on empathy, 502  
 on erythrophobia, 523  
 Fairbairn and, 545  
 on female sexuality, 105, 365, 571, 574, 576  
 Ferenczi and, 580, 651, 892  
 First World War and, 585–586  
 Flügel and, 593, 594  
 Freud, Anna and, 619  
 Freud, Ernst and, 622  
 on Freud-Bernays, 620  
 Freud biography by, 611, 642, 643, 644, 651, 893, 973–974  
 Freud-Jung split and, 1200, 1260  
 Freud U.S. visit and, I:pl.16, 207, 587  
 on functional phenomenon, 655  
 German psychoanalysis and, 675  
 Glover, James and, 684, 685, 686  
 Gross and, 707  
*Hamlet and Oedipus*, 723–724  
 on Herbart, 82  
 Hogarth Press and, 753  
 Hungarian psychoanalysis and, 580  
 on *Inhibitions, Symptoms, and Anxiety*, 833  
*International Journal of Psychoanalysis, The* and, 698, 853, 860, 893  
 International Psychoanalytical Association and, 854, 856  
*Internationale Zeitschrift für Psychoanalyse* and, 860  
 Internationaler Psychoanalytischer Verlag and, 861  
 Italian psychoanalysis and, 879  
 Jankélévitch and, 887  
 Kemper, Werner Walther and, 910  
 Klein and, 697  
 on lay analysis, 951, 1432  
 Malinowski and, 1005  
 Nazi Germany and, 681, 725  
 on nightmares, 1150  
 Norwegian psychoanalysis and, 1157  
 on occultism, 1181  
 “Outline of Psychoanalysis, An” and, 1216  
 on phallic mother, 1261  
 photographs of, I:pl.16, II:pl.16, III:pl.9  
 on privation, 1326  
*Psychanalyse, La* and, 1348  
 psychoanalytic filiations and, 1373  
 on *Psychoanalytic Review, The* and, 1380  
*Psychoanalytic Review* and, 889  
 on psychotherapy, 1412  
 Putnam and, 1424  
 Rank and, 1445  
 on rationalization, 1448  
*Revue française de psychanalyse* and, 1498  
 Riviere-Hodgson Verrall and, 893, 1507, 1655  
*Rivista di psicoanalisi* and, 1508  
 Russian/Soviet psychoanalysis and, 1518  
 Rycroft and, 1520  
 Schur and, 628  
 on scopophilia, 1553  
 Second World War and, 1557, 1558  
 Secret Committee and, 640, 854, 1193, 1561  
 on *Secrets of a Soul, The*, 1563  
 Servadio and, 1586  
 on Shakespeare, 1597  
 Silberer and, 1608  
 Société psychanalytique de Paris and, 1624  
 splits in psychoanalysis and, 1644  
*Standard Edition* and, 1654–1655, 1662–1663  
 Sterba and, 1658, 1659  
 on suicide, 1686  
 on symbolism, 190, 442, 1707, 1712  
 Tavistock Clinic and, 1727  
 Walter and, 1847  
 on war neuroses, 1848  
 Wiener psychoanalytische Vereinigung and, 1858
- Jones, Maxwell, 700
- Jordán, Juan Francisco, 285
- Jorn, Asger, 390
- Jornal de psicanálise*, 217
- Joseph, Betty, 132
- Joseph, Edward, 858, 1627, 1833
- Jouissance, **894–896**  
 death instinct and, 372  
 ethics and, 526  
 fantasy and, 552  
 masochism and, 1022

## INDEX

Volume 1, pp. 1–662; Volume 2, pp. 663–1344; Volume 3, pp. 1345–1892

- Name-of-the-Father and, 1104  
 object *a* and, 1173  
 philosophy and, 1271  
 repetition compulsion and, 1475  
 sexuation and, 1596  
 subject's castration and, 1676–1677  
 suffering, 1684  
 symptoms and, 1718  
*Journal de la psychanalyse de l'enfant*, 410, 896, 955, 1084  
*Journal de psychologie normale et pathologique*, 1054  
*Journal d'un médecin malade* (Allendy), 46, 896–897  
*Journal français de psychiatrie, Le*, 1084  
*Journal of Analytical Psychology*, 80, 1581  
*Journal of Psychohistory, The*, 1394  
*Journal of the American Psychoanalytic Association (JAPA)*, 897–898, 1548  
*Journey Within, The* (Rolland), 1182, 1511  
 Jouve, Pierre Jean, 898, 1493, 1537  
 Jouve-Reverchon, Blanche, 330  
 Joyce, James, 38, 986, 1719  
 József, Attila, 146–147  
 Jucovy, M., 846  
 Judaism, 898–900  
 Arlow and, 119  
 Bernays-Freud, Minna and, 168  
 Bleger and, 194  
 Freud, Jakob Kolloman and, 624, 1269  
 Freud-Bernays and, 620  
 Freud's self-analysis and, 425  
 German psychoanalysis and, 675  
 Kraus and, 924  
 mysticism and, 1091  
 parricide and, 1078  
 Wiener psychoanalytische Vereinigung and, 1857  
 Zweig, Arnold and, 1890  
 Judgment of condemnation. *See* Condemning judgments  
 Juelich, Dierk, 679  
 Juillerat, Bernard, 93, 1769  
 Julien, Philippe, 1084  
*Julius Caesar* (Shakespeare), 1597  
 Juliusberger, Otto, 413, 674, 1881  
 Jumpertz, Benedetta, 1014  
 Jung, Carl Gustav, 638, 901–903  
 on active imagination, 14–15  
 on alchemy, 40  
 Allendy and, 46  
 on amplification, 67, 79, 865  
 analytical psychology and, 79  
 on animus/anima, 86–87, 313  
 on archetypes, 115, 414  
*Archives de psychologie, Les* and, 116, 302  
 Australian psychoanalysis and, 130  
 Bachelard and, 145, 1367  
 Baudouin and, 154, 155  
 Belgian psychoanalysis and, 157, 158  
 on belief, 159  
 on Bernays-Freud, Minna, 168  
 Binet and, 89  
 Binswanger and, 180  
 on birth dreams, 186  
 Bjerre and, 188  
 Brazilian psychoanalysis and, 217  
 Brill and, 227  
 British psychoanalysis and, 695  
 Burghölzli Asylum and, 180, 235, 236, 901–902, 1399  
 Burrow and, 237  
 Canadian psychoanalysis and, 246  
 Caruso and, 248  
 on collective unconscious, 67, 313  
 on compensation, 317, 865  
 on complexes, 319, 320–321, 557, 800, 902, 1872  
 counter-transference and, 639, 747  
 on cryptomania, 356  
 Czech psychoanalysis and, 360  
 definition of psychoanalysis and, 1363  
 Delgado and, 385  
*Delusions and Dreams in Jensen's "Gradiva"* and, 386–387  
 Desoille and, 400  
 on determinism, 401  
 Deuticke and, 403, 404  
 on dream interpretation, 864–865  
 Dutch psychoanalysis and, 1132  
 Eder and, 460, 461, 695  
 on ego, 463, 469–470  
 Eitingon and, 493  
 Ellenberger on, 497  
 on extroversion/introversion, 537–538  
 Ferenczi and, 580, 765  
 Flournoy, Henri and, 591  
 free association and, 616  
 Freud U.S. visit and, I:pl.16, 60, 207, 302–303, 587, 1424  
 Galton and, 720  
 German psychoanalysis and, 674  
 Gross and, 607  
 Hirschfeld, Elfriede and, 747  
 on imago, 800  
 on individuation, 811–812  
 International Psychoanalytical Association and, 79, 854, 902  
 Internationale Ärztliche Gesellschaft für Psychotherapie and, 49  
*Jahrbuch für psychoanalytische und psychopathologische Forschungen* and, 884  
 Jelliffe and, 889, 1379  
 Jones and, 892  
 Judaism and, 899  
 Jung-Rauschenbach and, 902, 903  
 Le Bon and, 954  
 on libido, 968  
 on literature, 986  
 Maeder and, 999  
 Marcinowski and, 1011  
 on midlife crisis, 1055  
 monism/dualism and, 1070, 1071  
 on mother goddess, 1080  
 Murray and, 1087  
 on mysticism, 1091, 1643  
 on mythology, 1094  
*Nervous Anxiety States and their Treatment* and, 1132  
 on numinous, 1164–1165  
 Nunberg and, 1165  
 Ossipov and, 1212  
 on paranoia, 1229  
 Pfister and, 1260  
 photographs of, I:pl.16, II:pl.17  
 Piaget and, 1282  
 on projection, 1337–1338  
*Psyche* and, 1351  
 on psychic energy, 1356  
 on psychological types, 1395–1396  
 “Psychology of the Unconscious, The”, 902, 1399–1400  
*Psychoterapia* and, 1411  
 on religion, 660, 1399, 1467  
 Rittmeister and, 1505  
 Rorschach and, 1394, 1513  
 Russian/Soviet psychoanalysis and, 1518  
 on schizophrenia, 1396, 1398–1399, 1540  
 Schneider and, 1544  
 Schreber case and, 1546  
 on self, 1580–1581  
 on self-consciousness, 1569–1570  
 on shadow, 1596–1597  
*Sigmund Freud: Life and Work* on, 973  
 Silberer and, 1608  
 Sokolnicka and, 1633  
 Spielrein and, 639, 747, 1620, 1639–1640  
 structuralism and, 1668  
 on sublimation, 1679

Volume 1, pp. 1–662; Volume 2, pp. 663–1344; Volume 3, pp. 1345–1892

- Swedish psychoanalysis and, 1697  
 Swiss psychoanalysis and, 1702  
 on symbolization, 1714  
 on symptom-formation, 1716  
 on synchronicity, 1719–1720  
 on telepathy, 1735  
 on transference, 1779, 1780  
 transference and, 8  
 Winterstein and, 1863  
 Wolff, Antonia and, 1871–1872  
 on word association, 1872  
*See also* Freud-Jung split  
 Jung-Rauschenbach, Emma, 902, **903–904**  
 Jungian Psychoanalytic Society and Institute, 1531  
 Jury, Paul, 276, **904**  
*Justice intérieure, La* (Interior justice) (Allendy), 46
- K**
- Kächele, Horst, 1520  
 Kadyrov, Igor, 1520  
 Kaes, René, 1632  
 Kaës, René  
 group analysis and, 610, 613, 710, 1371–1372  
 on intergenerational phenomena, 845, 1197  
 North African psychoanalysis and, 1156  
 Kafka, Franz, 708, 899  
 Kafka, John, 1885  
 Kagan, Abraham, 897  
 Kahn, Copelia, 1597  
 Kahn, Laurence, 1163  
*Kain* (Szondi), 1722  
 Kaiser, Hellmuth, 1734  
 Kakar, Sudhir, 808  
 Kalmanson, Denise, 825  
 Kaminer, Isidor, 679  
 Kamm, Bernard A., 1529  
*Kanmuryojukyo*, 39  
 Kann, Loë, 209  
 Kanner, Leo  
 on autism, 71, 136, 139  
 on infantile psychosis, 824, 825, 828  
 Kant, Emmanuel. *See* Kantianism  
 Kantianism, **905–906**  
 on civilization, 298  
 collective unconscious and, 313  
 on determinism, 401  
 grid and, 704  
 internal/external reality and, 847  
 Lacan and, 1271  
 memoirs of the future and, 1039  
 metapsychology and, 1270  
 nostalgia and, 1158, 1159  
 otherness and, 1214  
 preconception and, 1299  
 thing-presentations and, 1742  
 unconscious concepts and, 1817  
 Kantor, Jorge, 1254  
 Kaplan, Abraham, 1640  
 Kaplan, E. Ann, 294  
 Kardiner, Abram, **906–907**  
 American Academy of Psychoanalysis and, 58  
 Brazilian psychoanalysis and, 215  
 on civilization, 299  
 Fromm and, 651  
 Horney-Danielson and, 759  
 Radó and, 1441  
 U.S. psychoanalysis and, 1825  
 Karinthy, Frigyes, 765  
 Karl Abraham Institute, 166  
 Karpe, Richard, 361  
 Karpinska, Louise von, 82  
 Karush, Aaron, 907  
 Kasanin, Jascha, 1529, 1530  
 Kasbaoui, Monique, 1155  
 Kassowitz, Max, 842–843  
 Katan, Maurits, 191, 192, **907–908**, 1133  
 Katan-Rosenberg, Anny, **908–909**  
 Katchalov, Pavel, 1519, 1520  
 “Katharina” case, **909**  
 adolescence in, 26  
 neurasthenia and, 1136  
 primal scene and, 1310  
 Rie and, 1503  
 seduction scenes and, 1565  
 Kaufmann, Pierre, 1321  
 Kawin, Bruce, 296  
 Keats, John, 1124  
 Kehrer, Ferdinand, 1547  
 Keller, Tina, 154  
 Kemper, Katrin, 215, 217  
 Kemper, Werner Walther, **909–911**  
 Berliner Psychoanalytische Poliklinik and, 164  
 Brazilian psychoanalysis and, 214, 215, 217, 910–911  
 German psychoanalysis and, 678, 679  
 Göring and, 689  
 Rittmeister and, 1505  
 Schultz-Hencke and, 1547  
 Kempf, Edward, 1745  
 Kempner, Salomea, 676, 1557  
 Kennedy, Hansi, 1732  
 Kenworthy, Marion, 1445  
 Kernberg, Otto  
 on abandonment, 2  
 on analyzability, 81  
 on blank psychoses, 191–192  
 on borderline conditions, 202  
 Canadian psychoanalysis and, 244  
 on character, 270, 273  
 Chilean psychoanalysis and, 284, 285  
 on dependence, 392  
 on ego, 467  
 ego psychology and, 487  
 Ferenczi and, 766  
 on id, 779  
 International Psychoanalytical Association and, 859–860  
 Japanese psychoanalysis and, 888  
*Journal de la psychanalyse de l'enfant* and, 896  
*Journal of the American Psychoanalytic Association* and, 898  
 on narcissism, 1111, 1171  
 on narcissistic injury, 1113  
 on narcissistic withdrawal, 1117  
 on neutrality, 1144  
 on object relations, 1171–1172  
 object relations theory and, 1176  
 on paranoia, 1228  
 on psychosis/neurosis distinction, 1415  
 Russian/Soviet psychoanalysis and, 1520  
 on self, 1579  
 on suicide, 1687, 1688  
 U.S. psychoanalysis and, 1826  
 Kernberg, Paulina, 285  
 Kertbeny, Károly Mária, 743, 756–757  
 Kesselring, Rudolf, 1292  
 Kestemberg, Jean, **912–913**  
 on autistic capsule, 138  
 Congrès des psychanalystes de langue française des pays romans and, 331  
 group analysis and, 610  
 Kestemberg-Hassin and, 911  
 Lebovici and, 954, 955  
*Revue française de psychanalyse* and, 1499  
 Kestemberg-Hassin, Evelyne, **911–912**  
 on adolescence, 27  
 on anorexia nervosa, 91  
 on autistic capsule, 138  
 Congrès des psychanalystes de langue française des pays romans and, 331

## INDEX

Volume 1, pp. 1–662; Volume 2, pp. 663–1344; Volume 3, pp. 1345–1892

- European Psychoanalytical Federation and, 529
- Lebovici and, 954
- Racamier and, 1435
- Revue française de psychanalyse* and, 1499
- Schmideberg-Klein and, 1542
- Société psychanalytique de Paris and, 911, 1626
- on transference, 423
- Khan, Mohammed Masud Rasa, **913–914**
- on “as if” personality, 122
- on Blackett-Milner, 191
- child analysis and, 698
- on dependence, 392
- Language of Psychoanalysis, The*, 944
- Nouvelle Revue de psychanalyse* and, 1162, 1163
- Rycroft and, 1521
- on self, 1580
- on sleep/wakefulness, 1615
- Smirnoff and, 1617
- on voyeurism, 1843
- Khostov, Alexander, 1519
- Kierkegaard, Søren, 1535
- Kim, Sung Hee, 920
- Kinberg, Olof, 1697
- Kinder, Marsha, 296
- Kinderseminar, 165
- King, Father Leicester, 290
- King, Pearl, 229, 857
- Kirsch, Jean, 79, 1780
- Kitayama, O., 888
- Kizer, Manuel, 1832, 1833
- Klain, Edouard, 1884
- Klajn, Hugo, 1884
- Klajn, Vladislav, 1885
- Klauber, John, 1060
- Klaus, Carl, 1277
- Klein, Georges, 309
- Klein, Hillel, 877
- Klein, Sydney, 132, 138, 189, 960
- Klein-anna Freud conflict, 355, 1783, 1817–1818
- See also Controversial Discussions
- Klein-Reizes, Melanie, **914–916**
- on abandonment, 3
- Aberastury and, 4
- Abraham, Karl and, 5, 914
- on adaptation, 22
- on aggression, 34
- alpha function and, 51
- on ambivalence, 57, 683
- American Academy of Psychoanalysis and, 59
- on anal eroticism, 515
- on anal-sadistic stage, 74
- on anality, 72
- on anorexia nervosa, 91
- on anxiety, 100, 1676
- Anzieu and, 104
- on archaic, 111, 112, 113
- Argentinian psychoanalysis and, 117, 118–119
- on arrogance, 121
- on autism, 1809
- on basic assumptions, 151, 711
- on basic schizoid position, 96
- Berliner Psychoanalytisches Institut and, 166
- on beta-elements, 171
- Bick and, 177
- on biological bedrock, 183
- Bion and, 183, 184
- Bleger and, 194
- Boehm and, 198
- Bowlby and, 211
- Brazilian psychoanalysis and, 217
- on breast as good/bad object, 218–219
- on breastfeeding, 221
- Brierley and, 226
- British psychoanalysis and, 697, 699
- on castration anxiety, 101
- on castration complex, 254
- on change, 268
- Chicago Psychoanalytic Institute and, 278
- child analysis and, 76, 279, 280, 283, 618–619, 697–698, 915, 1366, 1731–1732, 1733
- on childhood, 281
- on children’s play, 281, 283
- Chilean psychoanalysis and, 285
- on claustrophobia, 306
- on combined parent figure, 316, 1262
- on compulsion, 323
- on conflict, 326
- Congrès des psychanalystes de langue française des pays romans and, 330
- Congrès mondial de psychiatrie and, 532, 539
- on container-contained, 340
- Corrao and, 347
- on counter-transference, 350, 1784
- on creativity, 352
- on cruelty, 355
- on death instinct, 175, 372, 373, 915, 1139
- on defenses, 374, 375
- definition of psychoanalysis and, 1363
- on depression, 70, 72, 102, 394, 395
- on depressive position, 395–396
- on developmental processes, 1330
- on dualism, 449, 1106
- on early Oedipus complex, 113, 219, 915, 1174, 1187, 1188
- on ego, 463, 467
- on emotions, 501
- on envy, 56, 508, 509–510
- on erotogenic masochism, 518
- Évolution psychiatrique, L’* and, 532
- on fantasy, 552
- on father, 1346
- on fatherhood, 558
- on female sexuality, 571, 576–577, 1186, 1263
- feminist views of psychoanalysis and, 576–577
- Ferenczi and, 59, 580, 914
- Finnish psychoanalysis and, 584
- on *Fort-da* game, 600
- French psychoanalysis and, 610
- Freund Toszeghy and, 645
- on frustration, 653, 654
- on fusion/defusion, 659
- German psychoanalysis and, 679
- on gifts, 683
- Glover, Edward and, 684
- on guilt, 100, 716–717, 718
- Heimann and, 730
- Hellman Noach and, 733
- on helplessness, 734
- on heroic self, 740
- Hungarian School and, 764
- on hypochondria, 771
- on id, 779
- on idealization, 784
- on idealizing transference, 785
- on identification, 790
- on imago, 800–801
- on *infans* stage, 812
- on infant development, 814, 815
- on infant observation, 817
- on infantile omnipotence, 822–823, 1106
- on infantile psychosis, 824, 826
- on infantile sexual curiosity, 829
- “Instincts and Their Vicissitudes” and, 839
- on internal/external reality, 848
- on internal objects, 849, 850
- on introjection, 870
- Isaacs-Sutherland and, 873–874

Volume 1, pp. 1–662; Volume 2, pp. 663–1344; Volume 3, pp. 1345–1892

- Israeli psychoanalysis and, 878  
 Italian psychoanalysis and, 598, 879, 880, 881  
 Japanese psychoanalysis and, 888  
 Jones and, 893  
 Kemper, Werner Walther and, 910  
 Kestemberg-Hassin and, 912  
 on knowledge instinct, 918  
*Language of Psychoanalysis, The*, 944  
 Lebovici and, 955  
 on libidinal development, 966  
 on logic, 990  
 on Love-Hate-Knowledge links, 996  
 Main and, 1003  
 on manic defenses, 396, 1007  
 on masturbation, 1026  
 on maternal, 1028  
 Mom and, 1068  
 Money-Kyrle and, 1069, 1070  
 Morgenstern-Kabatschnik and, 1073  
 on narcissism, 1106  
 on narcissistic neuroses, 1114  
 on negative transference, 1127–1128  
 on neuroses, 1139  
 on object, 1169  
 on object loss, 218, 994  
 object relations theory and, 1176  
 on omnipotence of thoughts, 1189  
 optical schema and, 1201  
 on oral eroticism, 516  
 on orality, 1202–1204, 1205  
 on paradox, 1226  
 on paranoia, 1227  
 on paranoid position, 1231  
 on paranoid psychosis, 1232  
 on paranoid-schizoid position, 100, 112, 113, 188, 194, 418, 816, 1232, 1233–1234, 1566  
 on part-objects, 1168, 1594  
 on phallic mother, 1261–1262  
 on phallic stage, 1263  
 on phobias, 1274–1275, 1276  
 Portuguese psychoanalysis and, 1297  
 on pregenital stage, 1186  
 on pregnancy fantasy, 1302  
 on primal, 1308, 1312  
 on primal scene, 1311  
 on primary object, 1317  
 on privation, 1326  
 on projection, 1336  
 on psychic energy, 1356  
*Psychoanalytic Study of the Child, The* and, 1381  
 psychology and psychoanalysis and, 1398  
 on psychoses, 21, 1404, 1422  
 on psychotic anxiety, 90  
 on psychotic defenses, 1414  
 on psychotic panic, 1416  
 on psychotic part of the personality, 1417  
 on purified-pleasure-ego, 1423  
 on quota of affect, 1433–1434  
 on reparation, 1472  
 on resistance, 1489  
 “Richard” case and, 1276, 1500–1501  
 Rickman and, 1501  
 Riviere-Hodgson Verrall and, 1507  
 Róheim and, 1510  
 Rosenfeld, Eva Marie and, 1514  
 Rosenfeld, Herbert and, 1514  
 Russian/Soviet psychoanalysis and, 1520  
 on sadism, 1022, 1526  
 on schizophrenia, 1540  
 Schimberg-Klein and, 1542  
 Sechehayé and, 1557  
 on selected facts, 1566  
 on self, 1567, 1579  
 Sharpe and, 1599  
 Simmel and, 1612  
 Smirnov and, 1617  
 on splitting, 984, 1646  
 on splitting of the object, 1642, 1648–1649  
 on stammering, 1653  
 Strachey and, 1663  
 Strachey-Sargent and, 1664  
 on structural theories, 1666  
 on sublimation, 1679  
 on suffering, 1684  
 on suicide, 1686  
 on superego, 1691  
 on suppression, 1694  
 Swedish psychoanalysis and, 1699, 1700  
 Swiss psychoanalysis and, 1701  
 on symbiosis, 1706  
 on symbolism, 1708  
 symbolization, 1713  
 Tausk and, 1727  
 on thought, 1747–1748  
 on tics, 1756  
 Torok and, 1765  
 true/false self and, 1582  
 on turning around, 1807  
 Tustin and, 1809  
 on ulcerative colitis, 1814  
 on unconscious fantasies, 115, 1817  
 on urethral eroticism, 517  
 U.S. psychoanalysis and, 992–993, 1888  
 on “vagina dentata” fantasy, 1831  
 on visual arts, 1842  
 Waelder and, 1845  
 on weaning, 1851  
 Winnicott and, 1861, 1862  
 Wittkower and, 1870  
*Zeitschrift für psychoanalytische Pädagogik* and, 1886  
 Zetzel-Rosenberg and, 1887, 1888  
*See also* Controversial Discussions; Klein-anna Freud conflict; Object relations theory; Paranoid-schizoid position; Projective identification  
 Kleinman, Arthur, 1775  
 Kleinsorge, H., 678  
 Kleist, Heinrich von, 1524, 1656  
*Klinische Studie über die halbseitige Cerebrallähmung der Kinder* (Freud and Rie), **916**, 1502  
 Kluckhohn, Clyde, 1087  
 Knapp, Peter Hobart, 124  
*Kneipzeitung*, 1585  
 Knife phobia, 1272  
 Knight, Robert P., 897  
 Knobel, Mauricio, 217  
 Knöpfmacher, Wolf, 1836  
 Knot, 554, **916–917**  
*See also* Borromean knot  
 Knowledge. *See* Epistemology; Knowledge instinct  
 Knowledge, links of, 995–996  
 Knowledge instinct, **917–918**, 1025, 1119, 1289–1290, 1747  
 Kobal, Milan, 1884  
 Koch, Adelheid Lucy, 214, 910, **918–919**, 1012, 1833  
 Kocourek, Jiri, 361  
 Koechlin, Philippe, 1766  
 Koerber, Heinrich, 674  
 Koffka, Kurt, 1047  
 Kofman, Sarah, 327, 577–578  
 Kogan, Ilani, 877  
 Köhler, Wolfgang, 1047  
 Kohut, Heinz, **919–920**  
 on abandonment, 2  
 on act/action, 9  
 on action-presentations, 13  
 on action-thought, 9, 13–14  
 on agency, 33  
 on alter ego, 52  
 on analyzability, 81  
 on “as if” personality, 122



## INDEX

Volume 1, pp. 1–662; Volume 2, pp. 663–1344; Volume 3, pp. 1345–1892

- Australian psychoanalysis and, 132  
 Bettelheim and, 173  
 on bipolar self, 185  
 on borderline conditions, 203  
 on boredom, 203  
 Brazilian psychoanalysis and, 217  
 Burrow and, 237  
 on castration complex, 254  
 on change, 268  
 Chicago Psychoanalytic Institute and, 277, 278–279  
 on compensatory structures, 318  
 definition of psychoanalysis and, 1364  
 on disintegration anxieties, 90, 418  
 on dreams, 1579  
 on ego, 477  
 on ego-libido/object-libido, 486  
 on empathy, 502, 920  
 on fragmentation, 605  
 on grandiose self, 691, 1171  
 on id, 779  
 on idealized parental imago, 784  
 on idealizing transference, 785, 1116  
 on identity, 795  
 on identity preservation principle, 1324  
 Israeli psychoanalysis and, 878  
 on libido, 969  
 Los Angeles Psychoanalytic Society/Institute and, 993  
 on mirror transference, 1059–1060, 1115  
 on narcissism, 1107, 1111  
 on narcissistic injury, 1113  
 on narcissistic rage, 1113, 1115  
 on narcissistic transference, 920, 1115–1116  
 on narcissistic withdrawal, 1117  
 on progressive neutralization, 1331  
 on psychoanalyst role, 310  
 psychohistory and, 1394  
 psychology and psychoanalysis and, 1398  
 on purified-pleasure-ego, 1423  
 on self, 1567, 1579–1580  
 on self-image, 1572  
 on self-object, 56, 1574–1575  
 on self psychology, 467, 477, 503, 1576–1577  
 on sexualization, 1595  
 on splitting, 1650  
 on transference of creativity, 1787–1788  
 on transmuting internalization, 1798  
 on true/false self, 1582  
 on twinship transference, 52, 1810  
 U.S. psychoanalysis and, 1826, 1851
- See also* Self psychology  
*Koinos*, 347  
 Kojève, Alexandre, 795  
 Köller, Carl, 307  
 Koller, Carl, 1838  
 Komarova, Lola, 1519  
 Koolhaas, Gilberto, 1828, 1829  
 Kopper, Simo, 391  
 Korean psychoanalysis, **920–921**  
 Kosawa, Heisaku, 39, 887, 888, 920, **921–922**  
 Kosuth, Josef, 136  
 Kosztolányi, Dezsö, 765  
 Kotzebue, Otto von, 1723  
 Kouretas, Démétrios, 700, 701, **922**  
 Kovács-Prosznitz, Vilma, **922–923**  
 Ferenczi and, 580  
 Hungarian psychoanalysis and, 765, 766  
 Hungarian School and, 764, 766  
 Lorand and, 991  
 Róheim and, 923, 1509  
 Kraepelin, Emil  
 on acute psychoses, 21  
 Boehm and, 198  
 on delusions, 386  
 on dementia, 389  
 on dementia praecox, 1053, 1057  
 on erotomania, 521  
*Évolution psychiatrique, L'* and, 532  
 Gross and, 707  
 on infantile psychosis, 824  
 Lacan and, 36–37  
 on paranoid psychosis, 1232  
 on paraphrenia, 1234  
 on phobias, 1272  
 on psychosis, 36–37  
 on schizophrenia, 1540  
 Schreber case and, 1545, 1546  
 on secondary narcissism, 1110  
 “Wolf Man” case and, 1221  
 Krafft-Ebbing, Richard von  
 on activity/passivity, 16  
 on anxiety neurosis, 1136  
 on heterosexuality, 743  
 on homosexuality, 757  
 on libidinal development, 965  
 on masochism, 1020  
 on perversion, 1257  
 on sadism, 1525  
 on sadomasochism, 1527  
 on sexual bondage, 556  
 on sexuality, 1751
- Stekel and, 1657  
 Weininger and, 1852  
 Kraus, Karl, 543, **923–924**, 1868–1869  
 Kravtsov, Boris, 1520  
 Kreisler, Léon  
 on allergies, 47, 48  
 on child analysis, 280  
 on deprivation, 397  
 on helplessness, 734  
 on hospitalism, 761  
 on prematurity, 1304  
 on stranger anxiety, 1665  
 Kretschmer, Ernst, 37, 49, 902  
 Kris, Ernst, **924–925**  
 Czech psychoanalysis and, 361  
 definition of psychoanalysis and, 1364  
 ego psychology and, 466, 475  
*Gesammelte Werke* and, 680  
 Greenacre and, 702  
 Hartmann and, 727, 728  
 on identification, 790  
 Imago Publishing Company and, 802  
 Lehrinstitut der Wiener psychoanalytischen Vereinigung and, 959  
 Loewenstein and, 989  
 on metapsychology, 1049  
 on neutrality, 1144  
 New York Psychoanalytic Institute/Society and, 1148  
 photograph of, II:pl.18  
*Psychoanalytic Study of the Child, The* and, 492, 728, 1381  
 on psychosexual development, 1407  
 on self, 1579  
 on Shakespeare, 1598  
 on stages, 1652  
 U.S. psychoanalysis and, 1824, 1825  
 on visual arts, 1842  
 Waelder and, 1845  
 Kris-Rie, Marianne, **925**  
*Freud, The Secret Passion* and, 644  
 Lehrinstitut der Wiener psychoanalytischen Vereinigung and, 959  
 New York Psychoanalytic Institute/Society and, 1148  
 photograph of, II:pl.19  
 Rie and, 1503  
 Kristeva, Julia  
 on alterity, 1774  
 on female sexuality, 365, 571  
 feminist views of psychoanalysis and, 577, 578  
 on literature, 987

Volume 1, pp. 1–662; Volume 2, pp. 663–1344; Volume 3, pp. 1345–1892

- on myth of origins, 1092  
 on nonverbal communication, 1154  
 on pregnancy fantasy, 1303  
 on signifiers, 1605  
 “Kritik der Freudischen Theorien” (Bleuler), 195  
 Kroeber, Alfred Louis, 1321  
 Kronengold, Eduard, 1659  
 Krüll, Marianne, 642, 900, 1143  
 Krusenstern, Adam J. von, 1723  
 Krystal, Henry, 1382  
 Kubie, Lawrence, 227, 897, 1824  
 Kucera, Otakar, 361, 1292  
 Kuchta, Jan, 1292  
 Kuhn, Roland, 569, 1267  
 Kühnel, G., 677, 678  
 Kuiper, Piet, 1060  
 Kulka, Raanan, 878  
 Kulovesi, Yrjö, 584, 1698  
*Kultur*. See Civilization  
 Kumar R. Channi, Robson KM, 1297  
 Künkel, Fritz, 689  
 Kuntzel, T., 294  
 Kunz, Hans, 1061, 1351
- L**
- L and R schemas, **927–928**  
 La Barre, Weston, 1510  
 La Mettrie, Julien Offray de, 143  
 Labrecque, J. P., 243  
 Lacan, Jacques-Marie Émile, **928–932**  
 on adaptation, 22–23  
 “Aimée” case, 37–38, 104  
 on alienation, 43–44  
 Althusser and, 53, 611  
 on anxiety, 18  
 Anzieu and, 104  
 Argentinian psychoanalysis and, 118, 119  
 Aubry Weiss and, 128  
 Aulagnier-Spairani and, 129  
 Austrian psychoanalysis and, 134, 135  
 on autism, 137  
 on automatism, 143  
 Beirnaert and, 156  
 Belgian psychoanalysis and, 158  
 Berge and, 161  
 on biological bedrock, 183  
*Bloc, Le—Notes de la psychanalyse* and, 195  
 on body image, 197  
 Bonaparte and, 974  
 on Borromean knot, 1173, 1270, 1271, 1454, 1761, 1763–1764  
 Bouvet and, 210, 211  
 Brazilian psychoanalysis and, 217–218  
 Canadian psychoanalysis and, 244, 245  
 Caruso and, 249  
 on castration complex, 252, 254  
 Cénac and, 261  
 Certeau and, 266  
 Champ Freudien, Le and, 611  
 on change, 268  
 Chertok and, 277  
 on child analysis, 280  
 on cinema, 294, 295–296  
 Clark-Williams trial and, 304  
 Colloque sur l’ inconscient and, 314, 969  
 on compulsion, 323  
*Confrontation* and, 328  
 Congrès des psychanalystes de langue française des pays romans and, 330  
 Congrès mondial de psychiatrie and, 539  
 on cure, 359, 1385  
 Danish psychoanalysis and, 391  
 on death instinct, 175, 372, 373  
 on deferred action, 378, 381  
 definition of psychoanalysis and, 1363, 1364  
 Delay and, 383  
 on demand, 387–388  
 on determinism, 401  
*Development of Psycho-Analysis* and, 407  
 Diatkine and, 410  
 on disavowal, 417  
 on disintegration anxieties, 418  
 on displacement, 422  
 École de la Cause freudienne and, 455–456, 612, 931, 1083  
 École expérimentale de Bonneuil and, 456  
 École freudienne de Paris and, 266, 327, 457, 458, 930  
 École freudienne de Paris founding and, 457, 506  
*Écrits*, 37, 38, 459–460, 571, 611, 612  
 on ego, 463, 467, 475, 929  
 on Eros, 513  
 on erotogenicity, 521  
 on ethics, 526  
 on ethology, 528  
*Évolution psychiatrique, L’* and, 37, 532  
 Ey and, 539  
 on fantasy, 552, 553–554  
 on fascination, 556  
 on fatherhood, 558  
 on female sexuality, 365, 571, 1265  
 on femininity, 1596  
 feminist views of psychoanalysis and, 577, 578  
 Ferenczi and, 1739  
 on foreclosure, 595–596, 1121–1122, 1139, 1404, 1413, 1453, 1487, 1554, 1646  
 on formations of the unconscious, 597–598  
 on *Fort-da* game, 600  
 on four discourses, 601–602, 931  
 on frame of psychoanalytic treatment, 606  
 French psychoanalysis and, 608, 610–611, 612  
 on Freud, 1710  
 on frustration, 653–654  
 on fundamental rule, 656  
 on fusion/defusion, 659  
 on gaze, 990  
 German psychoanalysis and, 678  
 Granoff and, 692  
 on Graph of Desire, 554, 692–695, 895  
 Greek psychoanalysis and, 701  
 on hallucinatory, 722  
 Held and, 731  
 on heroic self, 739  
 on *I*, 775, 793  
 on id, 779  
 on ideal ego, 481  
 on identification, 787, 790  
 on identificatory project, 794  
 on imaginary, 799  
 on imaginary identification/symbolic identification, 798–799  
 on imago, 801  
*Inconscient, L’* and, 806–807  
 on *infans* stage, 812, 813  
 on infantile psychosis, 826  
 on inhibition, 833  
 “Instincts and Their Vicissitudes” and, 839  
 on intergenerational phenomena, 846  
 on internal/external reality, 848  
 IPA excommunication, 162, 327, 427, 455, 611, 692, 930  
 Italian psychoanalysis and, 880  
 on *Jokes and their Relation to the Unconscious*, 892  
 on jouissance, 372, 552, 894–896, 1271  
 on Kantianism, 905–906  
 on knot, 916–917, 1454  
 on L and R schemas, 927–928  
 on lack of being, 1847–1848  
 Lampl-de Groot and, 938  
*Language of Psychoanalysis, The* and, 944  
 on Law of the Father, 950  
 on lay analysis, 951

## INDEX

Volume 1, pp. 1–662; Volume 2, pp. 663–1344; Volume 3, pp. 1345–1892

- Leclair and, 957  
 on letter, 961–962  
 on libido, 969–970  
 on linguistics, 982  
 on literature, 986, 987  
 Loewenstein and, 989  
 Mannoni and, 1009  
 Mannoni-Van der Spoel and, 1010  
 Martinican psychoanalysis and, 1014  
 Marxism and, 611, 1018  
 on masochism, 1022  
 on matheme, 1031–1032  
 Merleau-Ponty and, 1046  
 on metaphor, 1047–1048  
 on metonymy, 1050–1051  
 on mirror stage, 815, 1058–1059, 1107  
 monism and, 1071  
 mother goddess and, 1080  
 on myth of origins, 1092, 1239  
 Nacht and, 200, 1101, 1102–1103  
 on narcissism, 1107  
 on neuroses, 289  
 Nodet and, 1152  
 on object, 1170  
 on object *a*, 994, 1172–1173  
 on object loss, 994  
 object relations theory and, 1173, 1176  
 on optical schema, 1200–1202  
*Ornicar?* and, 1211, 1552  
 on Other, 1212, 1213  
 on overdetermination, 1217  
 Pankow and, 1222  
 on parade of signifiers, 1225  
 on pass, 1242–1243, 1430, 1770  
 on passage to the act, 18  
 Peraldi and, 1247  
 on perceptual identity, 1249  
 Perrier and, 1251  
 on perversion, 1255, 1259  
 on phallus, 1264–1265  
 philosophy and, 1270–1271  
 on phobias, 1275, 1276  
 photograph of, II:pl.20  
 Pichon and, 1284  
 Portuguese psychoanalysis and, 1297  
 on privation, 1326–1327  
*Psychanalyse, La* and, 1348  
 on psychic causality, 1354  
 on psychic energy, 1356  
 on psychoanalyst role, 1368  
*Psychoanalytic Quarterly, The* and, 1378  
*Psychoanalytic Study of the Child, The*  
 and, 1381  
 on psychoanalytic treatment, 1384,  
 1385, 1729  
 psychology and psychoanalysis and, 1398  
 on psychoses, 36–38, 192, 1404, 1405  
 on puberty, 1421  
 Quatrième Groupe and, 1430, 1645  
 Racamier and, 1436  
 Rimbault, Émile and, 1442  
 on Real, 1453–1454  
 on Real, Symbolic, and Imaginary father,  
 1452–1453  
 on repetition compulsion, 1475  
 on representation, 782  
 Russian/Soviet psychoanalysis and, 1519  
 Sainte-anne Hospital and, 1528  
 San Francisco Psychoanalytic Society and  
 Institute and, 1531  
 on scientific nature of psychoanalysis, 145  
*Scilicet* and, 611, 1552  
 scotomization and, 1554  
 on self-consciousness, 1569  
 on self-image, 1572  
 on self-representation, 1578  
 seminars, **1583–1584**  
 on sense/nonsense, 1584  
 on sexuation, 1588–1589, 1595–1596  
 on Shakespeare, 1598  
 on signifier/signified, 1606–1607  
 on signifiers, 1605  
 on signifying chain, 1607  
 on slips of the tongue, 1616  
 Smirnof and, 1617  
 Société française de psychanalyse founding  
 and, 129, 427, 930  
 Société psychanalytique de Paris and, 1624,  
 1625, 1629  
 Spanish psychoanalysis and, 1638  
 on specularization, 1840  
 on Spinoza, 1640  
 on splitting of the subject, 1649–1650  
 structural theories and, 1667  
 on structuralism, 1668–1669  
 on subject, 1673  
 on subject of the drive, 1674  
 on subject of the unconscious, 1675  
 on subject's castration, 1676–1677  
 on subject's desire, 1677–1678  
 on superego, 1691  
 surrealism and, 1695, 1696  
 Swedish psychoanalysis and, 1699  
 on symbolic, 1710–1711  
 on symbolism, 1708  
 on symbolization, 1714  
 on symptom-formation, 1716  
 on symptom/sinthome, **1718–1719**  
 theory development, 36–37  
 on Thing, 1743, 1814  
 on topology, 1761–1764  
 training analysis and, 1770  
 on truth, 1805  
 on unary trait, 1761, 1814–1815  
 on unconscious, 1307  
 U.S. psychoanalysis and, 1826  
 Venezuelan psychoanalysis and, 1833  
 Videman and, 335, 1835  
 on visual, 1840–1841  
 on voyeurism, 1843  
 on weaning, 1851  
 on “Wolf Man” case, 1139  
 on word-presentations, 1873, 1874  
*See also* French psychoanalytic  
 establishment split (1953); French  
 psychoanalytic establishment split  
 (1964); Mirror stage; Name-of-the-  
 Father  
 Lacava, Marta, 1829  
 Lack, 295  
 Lack of being, **1847–1848**  
 Lack of differentiation, **932–933**  
 Lacoste, Patrick, 294, 295  
 Lacoue-Labarthe, Philippe, 241, 327, 1271  
 Lacretelle, Jacques, 424  
 Ladame, François, 27, 1701  
 Ladame, Paul, 116  
*Lady in the Dark* (film), 293–294  
 Lafora, Gonzalo, 116  
 Laforgue, Délia, 1401  
 Laforgue, Paulette, 1634  
 Laforgue, René, **933–935**, 1625  
 Allendy and, 46, 934  
 on Baudelaire, 974  
 Berge and, 161  
 on Bonaparte, 199  
 Canadian psychoanalysis and, 245  
 Choisy and, 290  
 Claude and, 305  
 Congrès des psychanalystes de langue  
 française des pays romans and, 329  
 on disavowal, 416  
*Disque vert, Le* and, 423  
 Dolto-Marette and, 427  
 Eitingon and, 493  
 Embirikos and, 498  
 Ey and, 539

Volume 1, pp. 1–662; Volume 2, pp. 663–1344; Volume 3, pp. 1345–1892

- on failure neurosis, 544  
 Favez-Boutonier and, 559, 560  
 French psychoanalysis and, 607–608  
 Freud, Oliver and, 631  
 Göring Institute and, 609, 934  
 Hesnard and, 742  
 International Federation of Psychoanalytic Societies and, 852  
 Lacan and, 38  
 Leuba and, 962  
 Loewenstein and, 988  
 Nazi Germany and, 934, 963, 1401, 1557, 1625  
 neopsychanalysis and, 1131  
 North African psychoanalysis and, 1154, 1155  
 on perversion, 1258  
 photograph of, II:pl.21  
 Pichon and, 933, 1283, 1284  
*Psychanalyse et les névroses, La*, 46, 305, 934, 1345–1346  
*Psyché* and, 934, 1350  
*Psychopathologie de l'échec*, 934, 1401–1402  
*Revue française de psychanalyse* and, 200, 934, 1497, 1498  
 Sainte-anne Hospital and, 1528  
 Schlumberger and, 1541  
 on scotomization, 416, 933, 1284, 1553–1554  
 Société psychanalytique de Paris and, 199, 934, 988, 1236, 1623, 1624, 1625  
 Sokolnicka-Kutner and, 1292, 1634  
*Zeitschrift für psychoanalytische Pädagogik* and, 1886  
 Lafortune, Mireille  
 Canadian psychoanalysis and, 245  
 Congrès des psychanalystes de langue française des pays romans and, 329  
 Lagache, Daniel, **935–936**  
 Anzieu and, 104  
 Association psychanalytique de France and, 123, 611  
 Beirnaert and, 156  
 Belgian psychoanalysis and, 158  
 Berge and, 161  
 Bibliothèque de psychanalyse and, 611  
 Bouvet and, 210  
 Clark-Williams and, 303–304  
 Desoille and, 400  
*Documents et Débats* and, 426  
 on ego ideal, 480  
 Favez-Boutonier and, 559  
 French psychoanalysis and, 608, 609  
 French psychoanalytic establishment split (1953) and, 427, 560, 609, 930, 934, 1102, 1618–1619, 1625, 1644  
 French psychoanalytic establishment split (1964) and, 122, 123  
 on heroic self, 739, 740  
 on ideal ego, 481  
 on jealousy, 884–885  
*Language of Psychoanalysis, The* and, 935, 943–944  
 Loewenstein and, 989  
 on neutrality, 1144  
 Nodet and, 1152  
 Pankow and, 1222  
 on paranoia, 1230  
 on passion, 1244  
 Perrier and, 1251  
*Psyché* and, 1350  
 on repetition, 1473  
 on reverie, 555, 1493  
*Revue française de psychanalyse* and, 1499  
 Schiff and, 1537  
 Société française de psychanalyse and, 427, 935, 1618–1619  
 Société psychanalytique de Paris and, 1624  
 on sublimation, 1679  
 on transference, 422–423, 1473  
 Viderman and, 1835  
 on working-off mechanisms, 1877  
 Lagadec, Claude, 864  
 Laignel-Lavastine, Maxime, 382, 1236, 1528  
 Lainé, Tony, **936–937**  
 Laing, Ronald David, **937–938**  
 anti-psychiatry and, 699  
 Deleuze/Guattari and, 98  
 Rycroft and, 1521  
 Tavistock Clinic and, 1728  
 Lairy, Catherine G., 314  
 Laks Eizirik, Cláudio, 566, 567  
 Lamarckianism  
 collective unconscious and, 313  
 Darwinism and, 367  
 Ferenczi and, 1738  
 heredity of acquired characters, 736  
 ontogenesis and, 1197  
 phylogenesis and, 1278  
 prehistory and, 1303  
 Lambert, Johann Heinrich, 1266  
 Lamella, 969–970  
 Lampedusa, Princess of. *See* Tomasi di Palma di Lampedusa-Wolff Somersee, Alessandra  
 Lampérière, Thérèse, 506  
 Lampl, Hans, **939**  
 Bornstein and, 205  
 Dutch psychoanalysis and, 1133  
 Freud, Oliver and, 631  
 Hartmann and, 727  
 Lampl-de Groot, Jeanne, **938–939**  
 Dutch psychoanalysis and, 1133, 1134  
 on female sexuality, 571  
 German psychoanalysis and, 1060  
 Leeuw and, 958  
 Lehrinstitut der Wiener psychoanalytischen Vereinigung and, 959  
 Radó and, 1441  
 Lancashire witches, 1709  
 Landauer, Karl, **939–941**  
 death of, 676  
 Dutch psychoanalysis and, 1133, 1200  
 Foulkes and, 601  
 Fromm-Reichmann and, 652  
 German psychoanalysis and, 675, 725  
 Meng and, 1044  
 Nazi Germany and, 1557  
 Sigmund Freud Institute and, 1602  
*Zeitschrift für psychoanalytische Pädagogik* and, 1886  
 Lang, Andrew, 85, 1320  
 Lang, Jean-Louis  
*Documents et Débats* and, 426  
 French psychoanalytic establishment split (1964) and, 122  
 on infantile psychosis, 825  
 on prepsychosis, 1306  
 on psychogenesis, 610  
 Smirnoff and, 1617  
 Société française de psychanalyse and, 1619  
 Lange, Johannes, 37  
 Langer, Marie Glass Hauser de, **941–942**  
 Argentinian psychoanalysis and, 117, 118, 665, 941  
 Brazilian psychoanalysis and, 910–911  
 Federación psicoanalítica de América latina and, 566  
 Mexican psychoanalysis and, 1051  
*Questionamos* and, 216  
 Racker and, 1440  
 Swedish psychoanalysis and, 1700  
 Venezuelan psychoanalysis and, 1833  
 Langer, William L., 1393  
 Langignon, Colette, 428  
 Langlois, Jean-Louis, 245, 1621  
 Language, **942–943**  
 Abel on, 3–4  
 action-language, 11–12, 13

## INDEX

Volume 1, pp. 1–662; Volume 2, pp. 663–1344; Volume 3, pp. 1345–1892

- Alvarez de Toledo on, 55  
 aphasia, 106, 143, 212, 1042  
 body image and, 198  
 brain and, 212  
 Breton on, 224  
 concepts and, 323  
 dream symbolism and, 441  
 dreams and, 440  
 ethics and, 526  
 female sexuality and, 571  
 feminist views of psychoanalysis and, 578  
 formations of the unconscious and, 598  
 fundamental rule and, 656  
 ideational representation, 785–786  
*infans* stage and, 812–814  
 Judaism and, 900  
 knot and, 917  
 Lacan on, 730  
 lack of being and, 1848  
 literature and, 986  
 love and, 671  
 Merleau-Ponty on, 314  
 metaphor and, 1047–1048  
 mnemonic traces and, 1063  
 modern conflict theory on, 1065  
 multilingualism and, 1085–1086  
 myth of origins and, 1092, 1321  
 negation and, 1121, 1122  
 nonverbal communication and, 1153  
 Other and, 1213  
 parade of signifiers and, 1225  
 quota of affect and, 1433  
 representability and, 1477  
 reversal into the opposite and, 1495  
 seduction theory and, 670  
 signifier/signified and, 1606  
 signifiers and, 1605  
 surrealism and, 1695  
 word-presentations and, 1873–1874  
 work of the negative and, 1129  
*See also* Linguistics; Metaphor; Metonymy  
*Language and Insight* (Schafer), 1571  
*Language of Psychoanalysis, The* (Laplanche and Pontalis), **943–944**  
 on aphanisis, 105  
 on complementary series, 318  
 on contact, 338–339  
 on deferred action, 378  
 on experience of satisfaction, 535–536  
 on fate neurosis, 557  
 on guilt, 716, 717  
 on intentionality, 1478, 1482  
 Lagache and, 935, 943–944  
 on mastery, 1025  
 on psychical representative, 841  
 publication of, 124, 611  
 on self, 1579  
 on stages, 1652  
 on working over, 1878  
 Lantéri-Laura, Georges, 315  
 Lantos, Barbara, 343, 1509  
 Lanzer, Ernst, **944–945**  
*See also* “Rat Man” case  
 Lopicque, Louis, 423, 424  
 Lapinski, Michael, 1292  
 Laplace, Pierre Simon, 401  
 Laplanche, Jean  
 on applied psychoanalysis, 108  
 Bibliothèque de psychanalyse and, 611  
 on breastfeeding, 220, 221  
 Colloque sur l’inconscient and, 314, 315, 610  
 on compulsion, 323  
*Confrontation* and, 327  
 on contact, 338–339  
 on death instinct, 175  
 on deferred action, 381, 613, 1848  
 on destrudo, 400  
*Documents et Débats* and, 426  
 on drives, 447  
 on empathy, 502  
 Fédida and, 569  
 on frame of psychoanalytic treatment, 606  
 French psychoanalysis and, 608  
 French psychoanalytic establishment split (1964) and, 122  
 on fusion/defusion, 658, 659  
 on general theory of seduction, 669, 670, 1197, 1204, 1342, 1566  
 on guilt, 1239  
 on hallucinatory wish-fulfillment, 1866  
 on intergenerational phenomena, 846  
 on knowledge instinct, 918  
 on masochism, 1022  
 on maternal reverie, 1031  
 on object, 1170  
 object relations theory and, 1176  
 on ontogenesis, 1197  
 on oral stage, 1204  
 on parricide, 1239  
 on phobic neurosis, 1276  
 on primal fantasies, 848, 1307, 1308  
 on proton-pseudos, 1342  
*Psychanalyse à l’université* and, 124  
 on psychic representative, 1358  
 on psychosexual development, 1407  
 on reciprocal paths of influence, 1456  
 on remembering, 1467  
 on repetition, 1473  
 on repetition compulsion, 1475  
 on seduction theory, 1143  
 on self-consciousness, 1569  
 Société française de psychanalyse and, 1619  
 on sublimation, 1678, 1679  
 on suffering, 1683  
 on symbolization, 1713  
*See also* *Language of Psychoanalysis, The*  
 Lapuz, Lourdes, 1268  
 Larguier des Bancelles, J., 89  
 Lasègue, Charles, 1528  
 Lasselin, M., 42  
 Laswell, Harold, 1825  
 Latency, 325, 333, 337, 758  
*See also* Latent dream thoughts  
 Latency period, 205, **945–946**  
 Latent dream thoughts, 437, 438, 442, **946–948**, 1747  
 Lateral transference, 422–423, 1777  
 Laufer, Eglé, 29  
 Laufer, Egle, 577  
 Laufer, Moses, 27, 29, 1420  
 Launay, Jacques, 415  
 Laurent, Éric, 137, 458  
 Laurent, Eric, 1638  
 Laurent-Lucas-Championnière-Maugé, Odette, **948–949**  
 Lavie, Jean-Claude, 1008, 1619  
 Law and psychoanalysis, **949–950**  
 Law of the Father, **950**  
 Lawrence, D. H., 708, 1150  
 Lay analysis, 639, 854–855, 857, 858, **950–952**  
 American Psychoanalytic Association and, 61, 62–63, 857, 858–859, 951, 1432, 1644, 1823  
 Dutch psychoanalysis and, 1200  
 Freud on, 855, 951, 1118, 1432–1433  
 International Psychoanalytical Association and, 639, 854–855, 857, 858–859  
 Los Angeles Psychoanalytic Society/Institute and, 992  
 National Psychological Association for Psychoanalysis and, 1118  
 Pichon on, 1283  
 Rank and, 1445  
 Reik and, 951, 1118, 1432, 1463, 1558

Volume 1, pp. 1–662; Volume 2, pp. 663–1344; Volume 3, pp. 1345–1892

- San Francisco Psychoanalytic Society and Institute and, 1529
- Lazar-Geroe, Clara, 130–131
- Laznik-Penot, Marie-Christine, 799
- Le Beuf, Diane, 1330
- Le Bon, Gustave, 291, 555–556, **953–954**, 1214, 1685
- Le Guen, Claude
- on Oedipus complex, 1186
  - on primal repression, 1309
  - on repression, 1479, 1480, 1481, 1486, 1487
- Revue française de psychanalyse* and, 1499, 1500
- Société psychanalytique de Paris and, 1628, 1630
- Le Guillant, Louis, 1350
- Le Lay, Yves, 302, 432
- Le Porta, Ernesto, 215
- Le Rider, Jacques, 298
- Le Surréalisme au service de la Révolution*, 1695
- Leaning. *See* Anaclysis
- Learning from Experience* (Bion), 50, 171, 339, 704, **952–953**, 995, 1030, 1312
- Lebovici, Ruth, 1542
- Lebovici, Serge Sindel Charles, **954–956**
- on anaclitic depression, 70
  - analytic psychodrama and, 78
  - Association de santé mentale and, 610
  - Belgian psychoanalysis and, 157
  - on Berman, 167
  - Brazilian psychoanalysis and, 216
  - Centre Alfred-Binet and, 263, 955
  - child analysis and, 280, 610, 613, 955, 1732, 1784
  - Colloque sur l' inconscient and, 314
  - communism and, 609
  - Congrès des psychanalystes de langue française des pays romans and, 330
  - Croatian psychoanalysis and, 1884
  - on dependence, 392
  - on developmental disorders, 408
  - on developmental processes, 1330
  - Diatkine and, 410
  - Dolto-Marette and, 427
  - on early interactions, 454
  - French psychoanalysis and, 609, 613
  - Greek psychoanalysis and, 700
  - Heuyer and, 744
  - on hospitalism, 760
  - on indications/contraindications for psychoanalysis, 809
  - on infant development, 814
  - on infantile, 830
  - on infantile neurosis, 821
  - on infantile psychosis, 825, 826, 828
  - Institut de psychanalyse de Paris and, 609
  - on intergenerational phenomena, 846
  - International Psychoanalytical Association and, 857
  - Italian psychoanalysis and, 881
  - Japanese psychoanalysis and, 888
  - Journal de la psychanalyse de l'enfant* and, 896, 955
  - Kestenberg-Hassin and, 911
  - Nacht and, 954, 1102
  - on object, 1170
  - on phobias, 1275
  - on pregenital stage, 1186
  - on prematurity, 1305
  - on prepsychosis, 1306
  - on primary narcissism, 1110
  - Psyché* and, 1350
  - on puerperal psychoses, 1422
  - Racamier and, 1435
  - Schlumberger and, 1542
  - on self-consciousness, 1569
  - Société psychanalytique de Paris and, 954–955, 1625, 1626, 1627, 1630
  - on stranger anxiety, 1664
  - structural theories and, 1666
  - on termination of treatment, 1737
  - on tics, 1756
  - Venezuelan psychoanalysis and, 1833
- Lechat, Fernand, 157, 450–451, **956–957**
- Leclaire, Serge, **957–958**
- Association pour une Instance Tierce des Psychanalystes and, 957, 1084
  - Bloc, Le—Notes de la psychanalyse* and, 195
  - Colloque sur l' inconscient and, 314, 610
  - Confrontation* and, 327, 328, 612
  - on doubt, 436
  - École freudienne de Paris and, 457, 458
  - Enriquez-Joly and, 506
  - on erotogenicity, 521
  - French psychoanalysis and, 613
  - French psychoanalytic establishment split (1953) and, 692, 957
  - French psychoanalytic establishment split (1964) and, 611, 957
  - Inconscient, L'* and, 807
  - on pass, 1243
  - Perrier and, 1251
  - Psychanalyse, La* and, 1348
  - on psychogenesis, 610
  - Russian/Soviet psychoanalysis and, 1519
  - Société française de psychanalyse and, 1619
  - Société psychanalytique de Paris and, 1629, 1630
  - structuralism and, 1668
  - student protests (1968) and, 612
  - Leçons cliniques de psychiatrie* (Meynert), 57
  - Leeuw, Pieter Jacob Van der. *See* Van der Leeuw, Pieter Jacob
  - Lefebvre, Henri, 315, 610
  - Lefebvre, Paul, 245
  - Lefort, Robert, 137, 1732
  - Lefort, Rosine, 137, 1732
  - Left-wing philosophers, 37–38
  - Legal issues. *See* Law
  - Legendre, Pierre, 1439, 1632
  - Legros, Hélène, 887
  - Lehmann, Andrée, 156
  - Lehrinstitut der Wiener psychoanalytischen Vereinigung, 61, **959**
  - Lehrman, Philip R., II:pl.22, **960**
  - Leibniz, Gottfried Wilhelm, 1214, 1270, 1271
  - Leigh, Stanley, 1809
  - Leiris, Michel, 204, 1774
  - Leite Lobo, Fabio, 215, 566
  - Lejeune, Philippe, 1628
  - Lemieux, Marcel, 864
  - Lemkin, Raphaël, 1437
  - Lemlij, Moisés, 1254
  - Lemmertz, José, 215, 1015
  - Lenmalm, Frithiof, 1697
  - Lenormand, Henri-René, 607
  - Leonardo da Vinci, 750, 844, 960–961, 1525, 1551, 1679
  - See also Leonardo da Vinci and a Memory of his Childhood*
  - Leonardo da Vinci and a Memory of his Childhood* (Freud), 375, 750, 783, 787, 844–845, **960–961**, 985
  - applied psychoanalysis and, 108
  - on memories, 1041
  - on narcissism, 1105, 1190
  - “On the Sexual Theories of Children” and, 1195
  - on paranoia, 1229
  - on passion, 1243, 1244
  - on phallic mother, 1263–1264
  - as psychobiography, 1388
  - psychohistory and, 1393
  - on repetition, 1473, 1474
  - on screen memories, 1555
  - on secondary narcissism, 1111
  - on Spinoza, 1640

## INDEX

Volume 1, pp. 1–662; Volume 2, pp. 663–1344; Volume 3, pp. 1345–1892

- on thought, 1746, 1747  
 on visual arts, 1841  
 Leone Bicudo, Virginia, 919  
 Lerner, Leila, 1380  
 Leroi-Gourhan, André, 1739  
*Les formations de l'inconscient* (Lacan), 1649  
*Les Lois de l'imitation* (de Tarde), 1685  
 Lesche, Carl, 1699  
 Lester, Eva, 209  
*L'État amoureux* (David), 1656  
*L'État mental des hystériques* (Janet), 1670  
 Letter, the, **961–962**, 1605  
*Letters of Sigmund Freud 1879–1939, The*, 1601  
*Letters of Sigmund Freud and Arnold Zweig, The*, 1601  
*Lettre personnelles à monsieur le Directeur* (Mannoni), 1009  
 Leuba, John, **962–963**  
 Belgian psychoanalysis and, 157  
 Bouvet and, 210  
 Cénac and, 261  
 Clark-Williams and, 303, 304  
 Congrès des psychanalystes de langue française des pays romans and, 330  
 Delay and, 383  
 Dolto-Marette and, 427  
 Dubal and, 450  
 Favez-Boutonier and, 559  
 Favreau and, 561  
 Held and, 731  
 Laforgue and, 934  
 Loewenstein and, 989  
 Pasche and, 963, 1242  
*Psyché* and, 1350  
*Revue française de psychanalyse* and, 1498  
 Schlumberger and, 1541  
 Société psychanalytique de Paris and, 1625  
 Leunbach, J. H., 390  
 Leupold-Löwenthal, Harald, 133, 136, 1858  
 Levi Bianchini, Marco, 878, **963–964**, 1508  
 Lévi-Strauss, Claude  
 on breastfeeding, 222  
 on ethnography, 93  
 French psychoanalysis and, 610, 613  
 on incest, 804  
 on individual, 810  
 Lacan and, 930  
 on myth of origins, 1321–1322  
 on mythology, 1099  
 on Oedipus complex, 1186  
*Psyché* and, 1350  
 on signifiers, 1604  
 structural theories and, 1667  
 structuralism and, 1668  
 on trance, 1774  
 on unconscious, 1307  
 Levinas, Emmanuel, 1214, 1271  
 Levinson, Daniel J., 1055  
 Lévy, André, 1632  
 Lévy, Danièle, 957  
 Levy, David M., 906, 1825  
 Lévy, Kata, 766, 1610  
 Lévy, Lajos, 580, 765  
 Levy, Steven J., 897  
 Lévy-Bruhl, Lucien, 1035, 1337  
 Lévy-Bruhl, Odile, 129  
 Lévy-Valensi, Eliane Amado, 900  
 Lévy-Valensi, Joseph, 382, 1528  
 Lewin, Bertram D.  
 Brill and, 227  
 Canadian psychoanalysis and, 242  
 on claustrophobia, 306  
 on dream screen, 440–441  
 Federn, Paul and, 568  
*Journal of the American Psychoanalytic Association*, 897  
 on negative hallucination, 1125  
*Psychoanalytic Quarterly, The* and, 1377  
 Ross and, 1516  
 on sleep/wakefulness, 1614  
 Lewin, Kurt, 713, 1632  
 Lewinter, Roger, 195, 706  
 Ley, Roberto, 941  
 Lhermitte, Jean, 1350  
 Liapounov, Alexandre, 256  
 Liberman, David, 117, 118, 566, 964, **964**, 980–981  
 Libidinal development, **964–967**  
 Abraham, Karl on, 5–6, 38, 56–57, 966, 967, 1038  
 activity/passivity and, 17  
 adolescence and, 28, 29  
 ambivalence and, 56–57  
 anality and, 72  
 breastfeeding and, 221  
 choice of neurosis and, 288  
 erotogenic masochism and, 517–518  
 erotogenic zones and, 518  
 ideational representation and, 785–786  
 Klein on, 915  
 Lacan on, 38  
 melancholia and, 1038  
 ontogenesis and, 1198  
 organization and, 1208  
 sadism and, 1205  
 subject's castration and, 1676  
*See also* Infantile sexuality; Psychosexual development  
*See also specific stages*  
 Libidinal stages, **966–967**, 1184–1185  
*See also* Libidinal development  
 “Libidinal Types” (Freud), 969, 1117  
 Libido, **967–971**  
 Aberastury on, 5  
 Adler on, 25  
 adolescence and, 27  
 alcoholism and, 41  
 altruism and, 54  
 analytical psychology on, 79  
 Andreas-Salomé on, 84  
 anticathexes and, 94  
 biological bedrock and, 182  
 boredom and, 203  
 cathexis and, 260  
 character and, 271  
 Dolto-Marette on, 1346  
 drives and, 444  
 ego and, 463  
 ego-instincts and, 483  
 ego-libido/object-libido, 484–486  
 envy and, 508, 509  
 Freud-Jung split and, 485, 486, 902, 968, 1191  
 hypochondria and, 770  
 id and, 778  
 Jung on, 1400  
 Kardiner on, 907  
 masculinity/femininity and, 1594  
 psychic energy and, 1356  
 regression and, 968, 1460  
 Sartre on, 1535  
 Schultz-Hencke on, 1547  
 sexual drive and, 444  
 skin and, 1612  
 Spinoza and, 1640  
 stages and, 1651, 1652  
 stammering and, 1653  
 transitional phenomena and, 1794  
 unused, 1604  
*See also* Libidinal development; Sexual drives  
 “Libido, La” (Allendy), 46  
 “Libido Theory, The” (Freud), 372, 485, 1105, 1486, 1538  
 “Library of Psychology and Psychoanalysis”, 1543  
 Lichtenberg, Georg, 891

Volume 1, pp. 1–662; Volume 2, pp. 663–1344; Volume 3, pp. 1345–1892

- Lichtenberg, Joseph, 1851
- Lichtenstein, Heinz, 794–795, 1323, 1324, 1567
- Liebeault, Ambroise Auguste, 170, 332, 768–769, **972–973**  
on suggestions, 1684, 1685
- Liebermann, David, 285
- Liebermann, H., 1758
- Liégeois, Jules, 331
- Lien social, Le*, 241
- Lies, **971–972**
- Life and Work of Sigmund Freud* (Jones). *See Sigmund Freud: Life and Work*
- Life and Works of Edgar Allen Poe: A Psychoanalytic Interpretation* (Bonaparte), **974–975**
- Life drive, 1646
- Life instinct (Eros), **975–976**  
*Beyond the Pleasure Principle* on, 179  
biological bedrock and, 182  
castration complex and, 255  
conflict and, 326  
culture and, 297  
death instinct and, 371, 372, 511–512  
drives and, 446  
dualism and, 449  
Eros and, 511–512, 513  
excitation and, 534  
Freud on, 174–175, 297, 511–512, 513, 975  
fusion/defusion and, 658, 659  
guilt and, 716  
id and, 777  
identification and, 788  
libido and, 1589  
sexual drives and, 975, 1589  
sexuality and, 1593
- Life Narcissism, Death Narcissism* (Green), 1107, 1117, 1807
- Life of One's Own, A* (Field), 190
- Life of Ramakrishna, The* (Rolland), 1181
- Life of Vivekananda and the Universal Gospel, The* (Rolland), 1181
- Lifting of amnesia, **976–977**
- Lifton, Robert Jay, 1393, 1445
- Lifwynn Institute, 238
- Lijtenstein, Marcos, 1829
- Lilith* (film), 292
- Limentani, Adam, **978–979**  
Australian psychoanalysis and, 131  
British Psycho-Analytical Society and, 230, 978  
International Psychoanalytical Association and, 858, 978
- Khan and, 914  
photograph of, II:pl.23  
on Société psychanalytique de Paris, 1627
- Lindeman, Eduard, 242
- Lindemann, Erich, 208
- Lindner, S., 518
- “Lines of Advance in Psycho-Analytic Therapy” (Freud), 979–980, 1486
- Linguisteria, 1606
- Lingüística, Interacción comunicativa y Proceso psicoanalítico* (Lieberman), **980–981**
- Linguistics, **981–983**  
Abel, 3–4  
amphimixia and, 66  
Lieberman and, 964  
representation and, 782  
signifiers and, 1604  
*See also* Language
- Linking. *See* Attacks on linking
- Links, 983–984, **995–996**
- Linton, Ralph, 410, 651
- Lipiner, Salomon, 1836
- Lipps, Theodor, 502, 673, 891
- List, E., 135
- Listening, **984**
- Listening with the Third Ear* (Reik), 1118
- Literary creation, 1524
- Literature, **984–985, 986–987**  
Anzieu and, 105  
applied psychoanalysis and, 107–108  
Bachelard on, 145  
Bonaparte on, 200, 974  
Brazilian psychoanalysis and, 213–214  
Breton and, 223–224  
death and, 370  
Dostoyevsky, 351, 412, 413, 431–432, 985  
double in, 429, 434–435  
family romance and, 549  
First World War and, 696  
Freud on, 107, 351, 431–432, 984–985  
H.D., 429–431  
hero in, 1094  
infantile omnipotence and, 823  
Jouve, 898  
Katan on, 908  
Laforgue on, 974  
Mann, 50, 673, 674, 1008–1009  
Murray on, 1087  
passion and, 1244  
Reik on, 1463  
Rolland, 1510–1511
- Sharpe on, 1599–1600
- Littérature*, 1695
- “Littérature moderne et psychanalyse” (Allendy-Nel-Dumouchel), 45
- Little, Margaret, 1728
- “Little Arpád” case, 279, 787, **987–988**, 988, 1768
- “Little Hans” case, **75–76**  
aggression and, 34  
anticipatory ideas and, 95  
anxiety dreams and, 103  
castration complex and, 76, 251, 253, 254  
child analysis and, 75–76, 279–280, 690, 1366, 1783  
childhood and, 280  
condemning judgments and, 901  
cure and, 359  
defenses and, 375  
deferred action and, 378  
developmental disorders and, 408  
developmental processes and, 1329  
disavowal and, 415  
Eder and, 460  
family and, 547  
fatherhood and, 558  
identification and, 787  
incest and, 804  
infant observation and, 817  
infantile neurosis and, 75–76, 820–821  
infantile sexual curiosity and, 829, 1590  
inhibition and, 833  
“Little Arpád” case and, 988  
Name-of-the-Father and, 1104  
nuclear complex and, 1164  
Oedipus complex and, 76, 1184, 1185, 1322  
“On the Sexual Theories of Children” and, 1194–1195  
phobias and, 1274, 1276  
on pregenital organization, 1301  
primal scene and, 1310  
prohibition and, 1332  
psychology and psychoanalysis and, 1397  
Real, Symbolic, and Imaginary father and, 1452  
Real and, 1453  
representation of affect and, 1478  
sexual theories of children and, 1591  
substitute formations and, 1680  
thought and, 1746, 1747  
transference and, 1783  
Weininger and, 1587–1588, 1853
- Littoral*, 1084
- Lizarazo, Arturo, 315



## INDEX

Volume 1, pp. 1–662; Volume 2, pp. 663–1344; Volume 3, pp. 1345–1892

- Lobo Moreira da Silva, Amilcar, 215–216
- Lockett, Regine, 679
- Loewald, Hans, 1176
- Loewenfeld, Heinrich, 360
- Loewenfeld, Yela, 360
- Loewenstein, Rudolph M., **988–989**  
on abstinence, 8  
on anti-Semitism, 291  
Canadian psychoanalysis and, 242  
Cárcamo and, 117, 247  
Cénac and, 261  
Chentrier and, 276  
Congrès des psychanalystes de langue française des pays romans and, 329, 330, 331  
definition of psychoanalysis and, 1364  
Dolto-Marette and, 427  
on ego-libido/object-libido, 486  
ego psychology and, 466, 475  
French psychoanalysis and, 608  
Geleerd and, 668  
Hartmann and, 728  
on homosexuality, 8  
on identification, 790  
Kris and, 925  
Lacan and, 608, 929  
Lagache and, 935  
Leuba and, 962  
on metapsychology, 1049  
Nacht and, 989, 1101, 1103  
Nazi Germany and, 1557  
on neutrality, 1144  
New York Psychoanalytic Institute/Society and, 1148  
Parcheminey and, 989, 1236  
photograph of, II:pl.24  
*Psychoanalytic Study of the Child, The* and, 1381  
on psychosexual development, 1407  
on racism/anti-Semitism, 1438  
*Revue française de psychanalyse* and, 988, 1498  
Sachs and, 988, 1523  
Saussure, Raymond de and, 1536  
on self, 1579  
on silence, 1610  
Société psychanalytique de Paris founding and, 199, 988, 1623  
on stages, 1652  
on training analysis, 1770  
U.S. psychoanalysis and, 1825  
Loewy, Emanuel, 163  
Logic, 738, **989–990**, 1816  
*Logic of Fantasy, The* (Lacan), 554  
“Logical Time and the Assertion of Anticipated Certainty” (Lacan), 929  
*Logique des sentiments, La* (Ribot), 1672  
*Logiques de l'inconscient, Les* (Neyraut), 990  
“Logos” (Heidegger), 930  
Logotherapy, 615  
Lomas, Peter, 1521  
Lombard, Pearl, 331, 1610–1611, 1628  
Lombroso, Cesare, 353, 1076  
Long, Constance, 685  
Longinus, 1678  
Look. *See* Gaze  
Loomie, Leo S., 1610  
López, M. I., 1052  
López-Ballesteros y de Torres, Luis, 175  
López-Corvo, Rafael E., 1833  
Lorand, Sándor, 242, 329, 764, **991–992**  
*L'Ordinaire du psychanalyste*, 1552  
Lorenz, Karl, 115, 528, 799  
Lorenz, Konrad, 1739  
Los Angeles Psychoanalytic Institute, Simmel and, 1611–1612  
Los Angeles Psychoanalytic Society and Institute, 1660  
Los Angeles Psychoanalytic Society/Institute, **992–993**  
Loss. *See* Mourning; Object loss  
“Loss of Reality in Neurosis and Psychosis” (Freud), 22, 1234, 1404  
Lost object. *See* Mourning; Object loss  
Lothane, Zvi, 1546  
Love, **994–995**  
Eros and, 513  
fascination and, 555–556  
genital, 670–671  
hatred and, 729  
jealousy and, 885  
links of, 995–996  
narcissism and, 1105  
narcissism of minor differences and, 1109  
passion and, 1243  
schizophrenia and, 310  
state of being in, 1656  
therapeutic alliance and, 1740  
transference and, 77, 513, 1785–1786  
*Love Against Hate* (Menninger), 1045  
“Love for the Mother and Mother Love” (Balint-Szekely-Kovács), 149  
Love-Hate-Knowledge links, **995–996**  
Love/hate opposition, 995  
depressive position and, 396  
fantasy and, 552  
Klein on, 326, 375, 396  
melancholia and, 1038  
negative therapeutic reaction and, 1126, 1782  
Oedipus complex and, 1187  
orality and, 1203  
subject of the unconscious and, 1675  
*Love Is Not Enough: A Treatment of Emotionally Disturbed Children* (Bettelheim), 173, 502–503  
Love object, renunciation of, 2  
Love trauma, 1656  
Loveland, Ruth, 960  
Lover's censure, 1170  
*Lovesick* (film), 293  
*Loving, Hating, and Living Well* (Greenson), 703  
Low, Barbara, 371, 417, 801, **996–997**, 1151, 1291  
Lowenfeld, Henry, 1825  
Löwenfeld, Leopold, 1136  
Löwenstein, Rudolph M.. *See* Loewenstein, Rudolph M.  
LSD, 55  
“Lucy R.” case, 495, **997–998**, 1086, 1488  
Ludwig, Ernst, 1838  
Luke, Helen M., 986  
Luquet, Pierre  
Congrès des psychanalystes de langue française des pays romans and, 331, 1625, 1628  
Leuba and, 963  
Portuguese psychoanalysis and, 1297  
on silence, 1610  
Société psychanalytique de Paris and, 1627  
Luquet-Parat, Catherine J., 576, 578  
Luria, Alexander, 1518  
Lussana, Pierandrea, 879  
Lussier, André, 243, 245, 1621  
Lustgarten, Siegmund, 1836, 1838  
*Lustprinzip*. *See* Pleasure principle  
Lutz, Jacob, 824, 827  
Luzes, Pedro, 1296, 1297  
Lyotard, Jean-François, 241, 1271  
Lyra, M. T., 215, 217
- ## M
- Maberino de Prego, Vida, 1829  
Mabille, Pierre, 1395  
*Macbeth* (Shakespeare), 1597  
MacCurdy, John, 1849  
Mach, Ernst, 704, 732, 1378, 1550, 1852  
MacLeod, Alastair, 242, 243  
Macrostructures, 1576

Volume 1, pp. 1–662; Volume 2, pp. 663–1344; Volume 3, pp. 1345–1892

- Maeder, Alphonse E., **999–1000**  
*Année psychologique, L'* and, 89  
*Archives de psychologie, Les* and, 116, 302  
 Pfister and, 1260  
 on Schreber case, 1546  
 Swedish psychoanalysis and, 189  
 Swiss psychoanalysis and, 1702  
*Magic Mountain, The* (Mann), 1008  
 Magical thinking, **1000**  
 animistic thought and, 85  
 archaic and, 112  
 contact and, 339  
 fundamental rule and, 657  
 omnipotence of thoughts and, 1189  
 taboo and, 1724  
 See also Superstition
- Magnan, Valentin, 143, 381, 412, 757, 827, 1528
- Magnetism. See Animal magnetism
- Magritte, René, 1618
- Mahler, Gustav, **1000–1001**, 1847
- Mahler-Schönberger, Margaret, **1001–1003**  
 on adolescence, 28  
 on autism, 136, 139, 503, 1001  
 Bak and, 147  
 Blos and, 197  
 boundary violations and, 209  
 Burrow and, 237  
 Canadian psychoanalysis and, 244  
 on developmental processes, 1330  
 on ego, 467  
 Hungarian School and, 764  
 on id, 779  
 on identity, 794  
 on individuation, 811, 815, 1598  
 on infantile psychosis, 824, 825  
*Journal of the American Psychoanalytic Association*, 897  
 Katan-Rosenberg and, 908  
 on lack of differentiation, 932  
 on negative hallucination, 1125  
 New York Psychoanalytic Institute/Society and, 1148  
 object relations theory and, 1176  
 on paranoia, 1228  
 photograph of, II:pl.25  
 on pregenital stage, 1186  
*Psychoanalytic Study of the Child, The* and, 1382  
 on purified-pleasure-ego, 1423  
 on self, 1582  
 on self-mutilation, 1573  
 on separation anxiety, 102  
 structural theories and, 1666  
 on symbiosis, 1705–1706  
 on tics, 1756  
 on unconscious fantasies, 1818
- Mahoney, Patrick J., 245
- Maiello, Suzanne, 896
- Mailloux, Father Noël, 242
- Main, Mary, 126, 822
- Main, Thomas Forrest, 601, 699, **1003–1004**, 1728
- Maison verte de Paris, 428
- Major, René  
*Cahiers Confrontation, Les* and, 240  
*Confrontation* and, 314, 327, 328, 612  
 Société psychanalytique de Paris and, 1627  
 Viderman and, 1835
- Malamoud, Charles, 241
- Malandrin, Marie-Hélène, 428
- Maldavsky, D., 419
- Mâle, Pierre, **1004–1005**  
 on adolescence, 27  
 child analysis and, 610  
 Claude and, 305  
 Ey and, 539  
 Held and, 731  
 Lacan and, 929  
 Loewenstein and, 989
- Malewski, Jan, 1292
- Malinowski, Bronislaw Kaspar, **1005–1006**  
 ethnopsychanalysis and, 527  
 on Oedipus complex, 1186  
 Reich, Wilhelm and, 1461  
 Róheim and, 1005, 1510
- Mallet, Jean, 1273, 1275
- Malomar Lund Edelweiss, Father, 217
- Man a Machine* (La Mettrie), 143
- Man Against Himself* (Menninger), 1045
- Man for Himself* (Fromm), 651
- Mänchen, Anna, 1529, 1530
- Mandalas, 812
- “Mangeur de rêves, Le” (Lenormand), 607
- Mania, **1006–1007**  
 acute episodes of, 21  
 manic defenses and, 396, 1007  
 melancholia and, 1082  
 self-representation and, 1578
- Manic defenses, 396, **1007**, 1036
- Manic-depressive disorders  
 acute psychoses and, 21  
 cocaine addiction and, 308  
 dipsomania and, 413  
 introjection and, 870  
 melancholia and, 1038  
 neuroses and, 1139  
 superego and, 1690
- Manifest dream elements, 437, 438, 442, 947, 948, **1007–1008**
- ego states and, 489  
 secondary revision and, 1007, 1559  
 thought and, 1747
- Mann, Thomas, 50, 673, 674, **1008–1009**, 1387, 1889
- Mannheim, Hermann, 684
- Mannoni, Dominique-Octave, **1009–1010**  
 Centre de formation et de recherches psychanalytiques and, 612, 1009, 1010, 1084  
*Confrontation* and, 327  
 Fanon and, 549  
 French psychoanalysis and, 612, 613  
 Groddeck and, 706  
*Psychanalyse, La* and, 1348  
*Psyché* and, 1009, 1350
- Mannoni-Van der Spoel, Maud, **1010–1011**  
 on autism, 137  
 Centre de formation et de recherches psychanalytiques and, 612, 1009, 1010, 1084  
 child analysis and, 610  
*Confrontation* and, 327  
 Dolto-Marette and, 427  
 École expérimentale de Bonneuil and, 456  
 Espace analytique, L' and, 611, 612, 1010, 1084  
 French psychoanalysis and, 612, 613  
 on infantile psychosis, 826  
 on pass, 1243  
*Psychanalyse, La* and, 1348
- Manquant, Marcel, 1014
- Manquant, Mrs. Marcel, 1014
- Man's Search for Meaning* (Frankl), 615
- Manta, Neves, 214
- Manuel alphabétique de psychiatrie* (Porot), 1098
- Manuel de psychiatrie* (Ey, Bernard, and Brisset), 540
- Manzano, Juan, 1701
- Mapelli, James, 247
- Marcano, Seráprio, 567
- Marcé, Louis-Victor, 91, 1298, 1421
- Marcinowski, Johannes, 674, **1011–1012**, 1411
- Marcondes, Durval Bellegarde, **1012–1013**  
 Brazilian psychoanalysis and, 214, 215, 216, 217, 919, 1012–1013, 1295  
 Franco da Rocha and, 614–615, 1012

## INDEX

Volume 1, pp. 1–662; Volume 2, pp. 663–1344; Volume 3, pp. 1345–1892

- Marcuse, Herbert, 31, **1013**  
 Austrian psychoanalysis and, 134  
 on capitalism, 1632  
 French psychoanalysis and, 612  
 Marxism and, 1013, 1018  
 philosophy and, 1271  
 on politics, 1293
- Marcuse, L., 1703
- Maréchal, J., 157
- Marette, Françoise. *See* Dolto-Marette, Françoise
- Marette, Philippe, 934
- Mariátegui, José Carlos, 1253, 1832
- Marie, Pierre, 106, 1529
- Marinescu, Gheorghe, 1511
- Mario and the Magician* (Mann), 1009
- Maritain, Jacques, 363, 1152
- Markovic, Aleksandr, 1884
- Markuszewicz, Roman, 1292
- Marmor, Judd, 993
- Marnie* (film), 293
- Marquez, J. A., 315
- Marr, Wilhelm, 1437
- Marseilles, Walter, 919
- Martin, I. H., 131
- Martin, R., 131
- Martinet, André, 1153
- Martinican psychoanalysis, **1013–1015**
- Martinique. *See* Martinican psychoanalysis
- Martins, Cyro, 215, 216, 566, 1015, **1015**
- Martins, Mário, 215, 216, 217, 1015
- Martins, Zaira. *See* Bittencourt de Martins, Zaira
- Marty, Pierre, **1015–1017**  
 on actual vs. defense neuroses, 20  
 on allergies, 47, 48  
 on anxiety neurosis, 1137  
 on asthma, 124  
 Bouvet and, 211, 1016  
 on character, 270, 273–274  
 on disintegration anxieties, 418  
 on disorganization, 420–421, 1460  
 on essential depression, 523  
 on excitation, 534  
 on fixation, 588  
 on fusion/defusion, 659  
 on mentalization, 1046  
 on operational thinking, 1198–1199  
 on organodynamic current, 1392  
 on preconscious, 1300–1301  
 on psychic causality, 1354  
 on psychic energy, 1356  
 on psychosomatic limit, 1409–1410  
 on psychosomatics, 610, 1016, 1198, 1407, 1408, 1409  
 Schlumberger and, 1016, 1542  
 Société psychanalytique de Paris and, 1016, 1626  
 on stranger anxiety, 1664  
 on work of the negative, 1130
- Marui, Kiyoyasu, 887, 921
- Marxism, **1017–1018**  
 Adler and, 1643  
 Adorno and, 31, 1018  
 on alienation, 43, 44  
 Althusser and, 53  
 Austrian psychoanalysis and, 134  
 Bernfeld and, 169, 1017  
 Bleger and, 193  
 Caruso and, 249  
 Deleuze/Guattari and, 98  
 Detski Dom and, 402  
 Fenichel and, 579  
 French psychoanalysis and, 612  
 Fromm and, 651, 1017  
 Gross and, 708  
 on ideology, 795–796  
 Lacan and, 611, 1018  
 Marcuse and, 1013, 1018  
 Morgenthaler and, 1074  
 philosophy and, 1271  
 politics and, 1293  
 Politzer and, 1294  
 Rittmeister and, 1505  
 surrealism and, 1695  
*Weltanschauung* and, 1855
- Masciangelo, Pier Mario, 1701
- Masculine protest, **1018–1019**  
 castration complex and, 252  
 narcissism and, 1105  
 penis envy and, 1246  
 primary narcissism and, 1110  
 rejection of femininity and, 575, 1018
- Masculinity/femininity, **1019–1020**  
 activity/passivity and, 16, 17, 576, 1020  
 animus/anima and, 86–87  
 bisexuality and, 186–187, 1019  
 castration complex and, 252  
 container-contained and, 340  
 feminist views of psychoanalysis and, 576, 577  
 gender identity and, 668–669, 1020  
 homosexuality and, 757  
 libido and, 1594  
*See also* Femininity
- Masks of Love and Life* (Sachs), 1524
- Masochism, **1020–1022**  
 active technique and, 16  
 activity/passivity and, 17, 1021  
 aggression and, 33  
 alcoholism and, 41  
 anal-sadistic stage and, 74, 518, 1021  
 anorexia nervosa and, 91  
 Bergler on, 153  
 character and, 271  
 conflict and, 326  
 death instinct and, 371, 372, 512  
 desexualization and, 399  
 Deutsch-Rosenbach on, 405  
 dismantling and, 420  
 Enriquez-Joly on, 506  
 Eros and, 513  
 erotogenic, 517–518, 1021, 1022, 1125, 1130, 1315–1316, 1475  
 ethics and, 526  
 feminine, 572, 576, 1021, 1022, 1258  
 fundamental rule and, 657  
 fusion/defusion and, 659  
 guilt and, 717, 1022  
 melancholia and, 1039  
 Nacht on, 1101  
 negative therapeutic reaction and, 1126  
 orality and, 1202  
 orgasm and, 1210  
 paranoia and, 1230  
 perversion and, 1258  
 sadism and, 1020, 1021, 1022, 1315, 1525–1526  
 self-mutilation and, 1572  
 self-punishment and, 1577  
 skin and, 1612, 1613  
 subject's castration and, 1676  
 suffering and, 1684  
 turning around and, 1806–1807, 1808  
*See also* Moral masochism; Sadomasochism
- Masochisme mortifère et Masochisme gardien de la vie* (Rosenberg), 1807
- Masotta, Oscar, 1638
- Mass Psychology and the Analysis of the Ego* (Freud), 1293
- Mass Psychology of Fascism, The* (Reich), 1018, **1022–1023**, 1461
- Massachusetts Institute of Psychoanalysis (MIP), 208
- Masserman, Jules, 58
- Massière, Jacqueline, 1350
- Masson, André, 1696

Volume 1, pp. 1–662; Volume 2, pp. 663–1344; Volume 3, pp. 1345–1892

- Masson, Jeffrey, 735, 1143  
 Master/slave dialectic, 43–44  
 Mastery, **1023–1026**  
   breastfeeding and, 221  
   cruelty and, 354, 355, 917, 1025  
   dipsomania and, 412, 413  
   erotogenic zones and, 519  
   knowledge instinct and, 917, 1025  
   mirror stage and, 1058, 1059  
   music and, 1088  
   patient physical position and, 541–542  
   sadism and, 1024, 1025, 1526  
 Masturbation, **1026–1027**  
   activity/passivity and, 17  
   addiction and, 23  
   adolescence and, 27, 29  
   Bornstein on, 205  
   dipsomania and, 412  
   dream symbolism and, 441  
   Eckstein case and, 454  
   feces and, 564  
   female sexuality and, 1635  
   jouissance and, 894  
   knowledge instinct and, 1747  
   mastery and, 1025  
   orgasm and, 1209  
   prohibition of, 1332  
   rituals and, 1503  
   sexual theories of children and, 1591  
   superego and, 205, 1026  
   tics and, 1756  
 Matecki, Wladislaw, 1292  
 Maternal, **1027–1028**, 1092  
 Maternal care, 136, **1028–1030**  
   *See also* Environment; Good-enough mother; Mother-infant bond  
 Maternal reverie, capacity for, 52, 127–128, **1030–1031**, 1169, 1317, 1340  
 Maternity, 1298  
 Matheme, **1031–1032**  
 Mathieu, Michel, 162  
 Mathieu, Pierre, 864  
 Mathilde case, **1032–1033**  
 Matic, Vojin, 1885  
 Matrix, 601  
 Matte-Blanco, Ignacio, **1033**  
   Chilean psychoanalysis and, 284, 285  
   Federación psicoanalítica de América latina and, 565  
   Italian psychoanalysis and, 881  
   on unconscious, 1816  
*Matter and Memory* (Bergson), 1042, 1043, 1351  
 Maturation, **1033–1034**, 1757  
*Maturational Processes and the Facilitating Environment*, The (Winnicott), 1107  
 Mauco, Georges, **1034–1035**  
   Berge and, 161  
   Centre psychopédagogique Claude-Bernard and, 265, 559, 609  
   Clark-Williams and, 304  
   Laforgue and, 934  
   *Psyché* and, 1350  
   Société française de psychanalyse and, 1619  
 Maudsley, Henry, 131, 695  
 Mauger, Jacques, 245  
 Maurey, Gilbert, 415  
 Maurois, André, 1350, 1387  
 Maurras, Charles, 661, 1283, 1624  
 Mauss, Marcel, 153, 1000, 1631  
 May, Rollo, 181, 1445  
 Maylan, Charles E., 1891  
 MBTI (Myers-Briggs Type Indicator), 1396  
 McCarthyism, 511  
 McDougall, Joyce  
   on alcoholism, 42  
   on anti-analysis, 75  
   on anxiety neurosis, 1137  
   on bulimia, 233  
   feminist views of psychoanalysis and, 576, 578  
   French psychoanalysis and, 613  
   *Inconscient, L'* and, 807  
   on indications/contraindications for psychoanalysis, 809  
   on infantile psychosis, 828  
 Lebovici and, 955  
   on perversion, 1256  
 Schlumberger and, 1542  
 Société psychanalytique de Paris and, 1626, 1628  
 McDougall, William, 696  
 McFarlane, Donald, 1529  
 Mead, George Herbert, 1567  
 Mead, Margaret, **1035–1036**  
   Devereux and, 410  
   Fromm and, 651  
   on Oedipus complex, 1186  
   U.S. psychoanalysis and, 1825  
   Wolfenstein and, 1870  
 Meaning, 1584  
 “Médecine ou philosophie?” (Poltzer), 1294  
 Mediation, 43, 44, 78  
 Mediator figures, 30  
*Médications psychologiques, Les* (Janet), 886  
 Medicine and psychoanalysis  
   Allgemeine Ärztliche Gesellschaft für Psychotherapie and, 49  
   American Psychoanalytic Association and, 61, 62–63, 856, 858–859  
   analyzability and, 81  
   Balint groups and, 147–148  
   Belgian psychoanalysis and, 157  
   Boston Psychoanalytic Society/Institute and, 207, 208  
   Brazilian psychoanalysis and, 217  
   British Psycho-Analytical Society and, 229–230  
   British psychoanalysis and, 696  
   Cénac on, 261  
   Clark-Williams trial and, 304, 609, 1034  
   École expérimentale de Bonneuil and, 456  
   Ey on, 539  
   German psychoanalysis and, 678–679  
   hysteria and, 773  
   lay analysis and, 950–951  
   payment for treatment and, 1069  
   *See also* Lay analysis  
   “Medusa’s Head” (Freud), 556, 990  
 Megalomania, **1036–1037**  
   borderline conditions and, 203  
   heroic self and, 740–741  
   mania and, 1006  
   narcissism and, 1106  
 Mehler, Anati, 1086  
 Mehler, Jacqueline Amati, 859  
 Meier, Carl A., 80  
 Meissner, William W., 1314  
 Melancholia, **1037–1039**, 1082–1083  
   abandonment and, 3  
   Abraham, Karl on, 6, 1037, 1038, 1039, 1082  
   acute episodes of, 21  
   ambivalence and, 21, 57, 1038, 1082  
   anal eroticism and, 514  
   anality and, 72  
   anorexia nervosa and, 91  
   anxiety and, 100  
   coprophilia and, 346  
   death instinct and, 372  
   ego and, 465  
   internal objects and, 849–850  
   mania and, 1006  
   megalomania and, 1036  
   mourning and, 21, 394, 1037–1038  
   narcissism and, 1106  
   object loss and, 994, 1037–1038  
   oral-sadistic stage and, 1038, 1082, 1203

## INDEX

Volume 1, pp. 1–662; Volume 2, pp. 663–1344; Volume 3, pp. 1345–1892

- self-punishment and, 1577  
 self-representation and, 1578  
 social feeling and, 1618  
 suicide and, 1687  
 ulcerative colitis and, 1813  
*See also* Depression  
 “Melancholia and Obsessional Neurosis” (Abraham), 1038  
 Melancholic depression. *See* Melancholia  
*Melancholy* (Botero), 1618  
 Mello Filho, J., 216  
 Melman, Charles  
 on alcoholism, 42  
 Association Freudienne internationale and, 1084  
 Centre d'études et de recherches freudiennes and, 1083  
 on dipsomania, 413  
 École de la Cause freudienne and, 455  
 École freudienne de Paris and, 458  
 Meltzer, Donald  
 on adhesive identification, 24, 137  
 on anality, 72  
 Argentinian psychoanalysis and, 118  
 on autism, 137, 138, 139  
 child analysis and, 1732, 1733, 1783  
 on dismantling, 419  
 on fantasy, 552  
 on hatred, 729  
 on infantile psychosis, 825  
 Italian psychoanalysis and, 879, 880  
 on Love-Hate-Knowledge links, 996  
 Portuguese psychoanalysis and, 1297  
 on postnatal depression, 1297  
 on pregenital stage, 1186  
 on psychotic defenses, 1414  
 on reparation, 1472  
 Simmel and, 1612  
 on splitting of the object, 1642  
 structural theories and, 1666, 1666  
 on sucking, 1682  
 Melville, Herman, 1087  
*Memoir of the Future, A* (Bion), 184, 1039–1040  
*Mémoire sur la découverte du magnétisme animal* (Mesmer), 84  
*Memoirs of My Nervous Illness* (Schreber). *See* Schreber case  
 Memoirs of the future, **1039–1040**  
 Memories, **1040–1042**  
 reminiscences, 1470–1471  
 screen memories, 26, 702, 1040, 1042, 1467, 1555–1556  
*See also* Memory  
*Memories, Dreams, and Reflections* (Jung), 902  
 Memory, **1042–1043**  
 constructions and, 335–338  
 cryptomnesia, 356–357, 591–592  
 dream-like, 439  
 Enriquez-Joly on, 506–507  
 fantasy and, 554  
 Greenacre on, 702  
 historical reality and, 748  
 “Note upon the ‘Mystic Writing Pad’, A” on, 1063–1064, 1160, 1340  
 remembering, 1467–1468  
*See also* Amnesia; Memories; Mnemic traces  
 Memory chains, 1040  
 Memory traces. *See* Mnemic traces  
 Menahem, Ruth, 1309, 1500, 1629  
 Menaker, Esther, 1445  
 Mendel, Gérard, 611, 612, 731, 1629, 1632  
 Mendes, Henrique, 215  
 Mendilaharsu, Carlos, 1829  
 Mendonça Uchôa, Darcy, 214, 216, 566  
 Mendoza, Josefina, 1052  
 Meng, Heinrich, **1044**  
 Federn, Paul and, 568  
 Fromm-Reichmann and, 652  
 German psychoanalysis and, 675, 940  
 Goethe Prize and, 687, 1044  
*Psyché* and, 1350  
*Rivista di psicoanalisi* and, 1508  
 Schneider and, 1544  
 Sigmund Freud Institute and, 1602  
 Swiss psychoanalysis and, 1703  
*Zeitschrift für psychoanalytische Pädagogik* and, 1886  
 Menninger, Karl A., **1045–1046**  
 on abstinence, 8  
 Brunswick and, 233  
 Devereux and, 409  
 Ellenberger and, 497  
 Kosawa and, 921–922  
 Menninger Clinic and, 1044  
 photograph of, II:pl.26  
 San Francisco Psychoanalytic Society and Institute and, 1529  
 on self-mutilation, 1572  
 Menninger, Will, 1529  
 Menninger Clinic, **1044–1045**, 1268, 1661  
 Menschik-Bendele, J., 135  
 Menstruation, 1616  
 Mentalization, 18, 69, 274, **1046**  
 Menzerath, Paul, 116  
 Mercier, Charles, 696  
 Merger transference. *See* Fusion transference  
 Meringer, Rudolf, 981  
 Merleau-Ponty, Maurice, **1046–1047**  
 Colloque sur l’ inconscient and, 314, 610  
 Dalbiez and, 363  
 French psychoanalysis and, 613  
 on phenomenology, 1047, 1266  
 philosophy and, 1271  
 Politzer and, 1294  
 Mesmer, Franz, 84, 497, 713  
*Metamorphoses of the Soul and its Symbols* (Jung), 1766  
 Metaphor, **1047–1048**  
 Arlow on, 119  
 cathexis and, 260  
 contact and, 339  
 displacement and, 422  
 formations of the unconscious and, 598  
 Freud’s use of, 260, 324, 367–368  
 linguistics and, 982  
 Sharpe on, 1600  
 signifier/signified and, 1606  
 signifying chain and, 1607  
 subject’s desire and, 1677  
 symptoms and, 1718  
 Metaphysics, 1640  
 “Metapsychological Supplement to the Theory of Dreams, A” (Freud), **1048–1049**  
 on amentia, 58  
 on day’s residues, 368  
 on hallucinatory wish-fulfillment, 1866  
 myth of origins and, 1092  
 on negative hallucination, 1124, 1477  
 on reality testing, 1451  
 on regression, 1116, 1460  
 on sleep/wakefulness, 1614  
 on somnambulism, 1636  
*Métapsychologie du sens* (Widlöcher), 13  
 Metapsychology, **1049–1050**  
 agency and, 33  
 amnesia and, 65  
 anticathexes and, 94  
 Aulagnier-Spairani on, 130  
 bipolar self and, 185  
 Bowlby on, 212  
 censorship and, 262  
 character and, 269  
 claustrophobia and, 306  
 compulsion and, 322  
 constructions and, 335

Volume 1, pp. 1–662; Volume 2, pp. 663–1344; Volume 3, pp. 1345–1892

- conversion and, 345  
deferred action and, 380  
dependence and, 392  
discharge and, 417  
*Ego and the Id, The* and, 470  
emotions and, 501  
empathy and, 502  
on excitation, 533  
experience of satisfaction and, 536  
Favreau on, 562  
fundamental rule and, 656, 657  
fusion/defusion and, 659  
hallucinatory and, 722  
hypnoid states and, 768  
id and, 779–780  
idealized parental imago and, 784  
incompleteness and, 805  
“Instincts and Their Vicissitudes” on, 838  
interpretation and, 863  
intersubjective/intrasubjective dichotomy and, 867  
It and, 201  
lay analysis and, 1432  
Marty on, 1016  
mnemic traces and, 1065  
myth of origins and, 1092  
mythomania and, 1098  
narcissistic injury and, 1112  
neurophysiology and, 213  
operational thinking and, 1198  
orgasm and, 1209  
pairs of opposites and, 1220–1221  
perception-consciousness system and, 1248  
perversion and, 1257–1259  
phantom and, 1265–1266  
philosophy and, 1270  
on preconscious, 1300–1301  
psychic causality and, 1354  
psychic energy and, 1355  
psychic representative and, 1358  
psychoanalytic research and, 1379  
psychobiography and, 1388  
puberty and, 1421  
“Remembering, Repeating and Working-Through” and, 1469  
repetition compulsion and, 1475  
representation and, 780, 781  
repression and, 1479–1480, 1483–1484  
Rubinstein on, 1517  
Schultz-Hencke on, 1547  
self-object and, 1575  
self psychology and, 1576  
semiology and, 1380–1381  
stages and, 1652  
structural theories and, 1666  
sublimation and, 1679  
substitute formations and, 1681  
superego and, 1691  
suppression and, 1694  
symbolization and, 442  
termination of treatment and, 77  
twinsip transference and, 1810  
unconscious and, 1820–1821  
as Witch, 1868  
work of the negative and, 1129  
*See also* Dynamic point of view; Economic point of view; Topographical point of view  
“Metapsychology” (Freud), 323, 786, 805, 838, 1257  
“Metapsychology of Pleasure, The” (Saussure), 1536  
“Méthode psychanalyse et les ‘Abwehr-Neuropsychosen’ de Freud” (Claude), 304  
*Méthode psychoanalytique, La* (Saussure), 1536  
*Métier des parents, Le* (Berge), 162  
Metonymy, **1050–1051**  
condensation and, 324  
contact and, 339  
demand and, 388  
displacement and, 422  
formations of the unconscious and, 598  
linguistics and, 982  
object *a* and, 1173  
signifier/signified and, 1606  
signifying chain and, 1607  
subject’s desire and, 1677  
Métraux, Alfred, 1774  
Mette, Alexander, 677  
Metz, Christian, 294, 295  
Mexican psychoanalysis, 651, **1051–1052**  
Mexican Psychoanalytic Association. *See* Asociación psicoanalítica mexicana  
“Mexican War Hieroglyphs” (Balint-Szekely-Kovács), 149  
Meyer, Adolf F., **1052–1053**  
Brill and, 227  
Burghölzli Asylum and, 236  
Burrow and, 237  
Freud U.S. visit and, 1822  
Frink and, 649  
Greenacre and, 702  
Hartmann and, 727  
Japanese psychoanalysis and, 887  
photograph of, II:pl.27  
Schilder and, 1538  
on schizophrenia, 1053, 1540  
Thompson and, 1745  
Washington Psychoanalytic Society and, 1849  
Meyer, J. E., 91  
Meyer-Palmedo, Ingeborg, 1669–1670  
Meyerson, Ignace, 887, **1053–1054**, 1677  
Meynert, Theodor, 637, **1054–1055**, 1837  
on amentia, 57–58, 1054  
Freud’s autobiography and, 139  
Kantianism and, 905  
Mathilde case and, 1032  
Mezzan, Renato, 216  
Michaux, Henri, 157  
Michaux, Léon, 824  
Michelangelo, 107, 985, 1079, 1659, 1842  
Michigan Association for Psychoanalysis, 1658  
Microstructures, 1576  
Midlife crisis, 30, 1055, **1055–1056**  
Mieres de Pizzolanti, Gloria, 1829  
Mijolla, Alain de  
on alcoholism, 42  
on cinema, 295  
*Confrontation* and, 327  
on Goethe, 687  
on heroic self, 739  
on identification, 790  
on identification fantasies, 791  
on individual, 811  
on intergenerational phenomena, 846  
International Association of the History of Psychoanalysis and, 851  
on phantom, 1266  
on primal fantasies, 1308  
on psychoanalytic treatment, 1729  
on secrets, 1560  
Société française de psychanalyse and, 1619  
Société psychanalytique de Paris and, 1628, 1629  
Mijolla-Mellor, Sophie de  
on certainty, 266  
on cinema, 294  
on drives, 447  
on ideology, 795, 796  
on jokes, 890  
on knowledge instinct, 918  
on parricide, 1239  
on passion, 1244  
on pleasure in thinking, 1289  
on Quatrième Groupe, 1430

## INDEX

Volume 1, pp. 1–662; Volume 2, pp. 663–1344; Volume 3, pp. 1345–1892

- on sense/nonsense, 1585  
 on thought identity, 1749  
*Topique* and, 1759  
 on truth, 1805  
 on uncanny, 1816  
 on work, 1876  
 Mikota, Vaclav, 361  
 Milieu therapy, 172  
 Military, 711, 1458  
 Milk. *See* Breastfeeding  
 Mill, John Stuart, 223, 1290, 1873  
 Miller, Emanuel, 684  
 Miller, Jacques-alain  
   Brazilian psychoanalysis and, 217  
   Champ Freudien, Le and, 611  
   École de la Cause freudienne and, 455, 612  
   École freudienne de Paris and, 458, 612  
   *Écrits* (Lacan) and, 460, 612  
   Italian psychoanalysis and, 880  
   Lacan and, 931  
   Lacan seminars and, 1583  
   *Ornicar?* and, 458, 1211  
   *Scilicet* and, 1552  
   Spanish psychoanalysis and, 1638  
   student protests (1968) and, 612  
 Miller, Jean Baker, 577  
 Miller, Judith, 455  
 Millet, Jack, 852  
 Millet, Kate, 576  
 Milner, Jean Claude, 327, 982  
 Milner, Marion, 937  
 Mind, 1348  
*Mind and Its Disorders* (Stoddart), 696  
 “Mind and its Relation to the Psyche-Soma” (Winnicott), 688  
 Minde, Klaus, 1304  
 Minkowska-Brokman, Françoise, 261, **1056**  
 Minkowski, Eugène, **1056–1057**  
   arrest of, 261  
   Colloque sur l’ inconscient and, 314, 315, 610  
   *Évolution psychiatrique, L’* and, 532, 539, 1283  
   French psychoanalysis and, 607–608  
   Minkowska-Brokman and, 1056  
   on mythomania, 1098  
   on phenomenology, 1057, 1267  
 Minkowski, Jeanine, 261  
*Minotaure*, 1695  
*Minutes of the Vienna Psychoanalytic Society*, **1057–1058**  
 MIP (Massachusetts Institute of Psychoanalysis), 208  
*Miracle grec, Le* (Saussure), 1536  
 Miró, Joan, 1695  
 Miró Quesada, Oscar, 1253  
 Mirror stage, **1058–1059**  
   child analysis and, 280  
   ego and, 467  
   ethology and, 528  
   *I* and, 775–776  
   ideal ego and, 481  
   identification and, 775, 790, 1107  
   identificatory project and, 793  
   infant development and, 815  
   infantile psychosis and, 826  
   L and R schemas and, 927  
   lack of being and, 1848  
   narcissism and, 1107  
   optical schema and, 1201  
   pictogram and, 1286  
   self-image and, 1572  
   Shakespeare and, 1598  
   visual and, 1840–1841  
 “Mirror Stage” (Lacan), 798, 813, 1578  
   on self-consciousness, 1569  
 Mirror transference, 52, **1059–1060**, 1115, 1580  
 Mirroring, 601  
 Mirski, Joseph, 1292  
*Mischung/Entmischung*. *See* Fusion/defusion  
 Misès, Roger  
   child analysis and, 280, 610  
   on infantile psychosis, 825  
   on phobias, 1276  
   on prepsychosis, 1306  
 Missenard, André, 610, 947  
 Mitchell, Juliet, 328, 576  
 Mitchell, Stephen, 1176  
 Mitrani, Judith, 125  
 Mitscherlich, Alexander, **1060–1061**  
   German psychoanalysis and, 677, 679, 1060  
   Marxism and, 1018  
   *Psyche* and, 1351  
   Sigmund Freud Institute and, 1602  
   Swedish psychoanalysis and, 1699  
   Swiss psychoanalysis and, 1703  
 Mitscherlich-Nielson, Margarete, 131, 677, 1351  
 Mnemic image, 1677  
 Mnemic symbols, 58, 179, 345, 1041, **1061–1062**  
 Mnemic traces, **1062–1065**  
   amnesia and, 64  
   biological bedrock and, 182  
   character and, 272  
   collective psychology and, 312  
   consciousness and, 334, 1063–1064, 1065  
   constructions and, 338  
   day’s residues, 367–368  
   deferred action and, 379, 380, 1064  
   *Development of Psycho-Analysis* on, 407  
   experience of satisfaction and, 536  
   fear and, 563  
   id and, 778  
   ideational representative and, 786  
   infantile amnesia and, 820  
   lifting of amnesia and, 976  
   maternal and, 1027  
   memories and, 1041  
   mentalization and, 1046  
   mnemic symbols, 58, 179, 345, 1041, 1061–1062  
   myth of origins and, 1093  
   representation and, 781  
   wishes and, 1867  
   word-presentations and, 1874  
   working over and, 1878  
   *See also* Day’s residues; Mnemic symbols  
 Möbius, August Ferdinand, 225  
 Möbius, Paul Julius, 1657  
 Möbius strip, 1667, 1761, 1814  
*Modelli psicoanalitici: Mito, Passione, Memoria* (Corrao), 347  
 Modern conflict theory, **1065–1067**  
*Modern Treatment of Nervous and Mental Diseases, The* (Jelliffe and White), 889  
 Modesty, **1067**  
 Moebius, Paul J., 1587  
*Moi-peau*. *See* Skin-ego  
*Mois chez les filles, Un* (Choisy), 290  
 Moll, Albert, 757, 965, 967  
 Mom, Jorge Mario, 118, **1067–1068**  
 “Moments d’une psychanalyse” (Jouve and Reverchon-Jouve), 898, 1493  
 Momogliano, Nissim, 881  
 Monakow, Constantin von, 195  
 Moncy, René de, 82, 1698–1699, 1831  
 Monette, Lise, 245  
 Money, **1068–1069**  
   anal eroticism and, 514, 519  
   erotogenic zones and, 519  
   feces and, 564  
   sublimation and, 1679  
 Money, John, 668  
 Money-Kyrle, Roger Earle, 696, 697, **1069–1070**, 1338  
 Monism, 20, 975, **1070–1071**, 1106

Volume 1, pp. 1–662; Volume 2, pp. 663–1344; Volume 3, pp. 1345–1892

- Moniz, Egas, 1295–1296  
 Monjauze, M., 42  
 Monod, Mireille, 78  
 Monroe, Marilyn, 644, 1503  
 Montagner, Hubert, 1618  
 Montaigne, Michel de, 1026  
 Montessori, Maria, 131  
 Montgrain, Noël, 245  
 Montrelay, Michèle  
   *Confrontation* and, 327  
   École freudienne de Paris and, 458  
   on female sexuality, 365, 574  
   feminist views of psychoanalysis and, 577  
   Peraldi and, 1247  
 Morais, Deodato de, 214, 1295  
 Moral anxiety, 1690, 1691  
 Moral ego, 1596  
 Moral masochism, 1021–1022, **1071–1072**  
   death instinct and, 372, 1072  
   Eros and, 513  
   erotogenicity and, 521  
   guilt and, 717, 1022, 1071  
   sadomasochism and, 1527  
   self-punishment and, 1577  
   superego and, 1071, 1072, 1691  
 Morane, George, 1732  
 Moreau de Tours, Jacques, 386, 827  
 Moreau de Tours, Jean-Jacques, 1672  
 Moreigne, Jean-Paul, 1430  
 Moreira, Julian, 213, 214, 1295  
 Morel, Bénédicte-augustin, 1178  
 Morel, Ferdinand, 1620  
 Moreno, Jacob Levy, **1072–1073**  
   analytic psychodrama and, 78  
   on group psychotherapies, 713, 1072, 1371  
   Kestemberg-Hassin and, 911  
   Lebovici and, 954  
 Moreno Robles, Alfonso, 1052  
 Morgan, Christiana, 1087  
 Morgenstern, Sophie, 1610  
 Morgenstern-Kabatschnik, Sophie,  
   **1073–1074**  
   child analysis and, 280, 1073  
   death of, 608  
   Dolto-Marette and, 427, 1073, 1346  
   Heuyer and, 744  
   *Rivista di psicoanalisi* and, 1508  
 Morgenthaler, Fritz, 1060, **1074**, 1703  
 Morichau-Beauchant, Pierre Ernest René,  
   196, 607, **1074–1075**  
 Moritz-Freud, Maria, **634–635**  
 Moro, Marie-Rose, 1775, 1849  
 Moroccan psychoanalysis, 1154, 1155  
 Morpurgo, Enzo, 880  
 Morra, Mauro, 879  
 Morselli, Enrico, 878, **1075–1076**  
   “Mort d’Œdipe, La” (Bloch), 196  
 Morton, Richard, 91  
 Mosbacher, Eric, 802  
 Moscovici, Marie, 124, 1078, 1628  
 Moscovici, Serge, 611, 1322, 1632  
 Moscow Psychoanalytic Institute, 1639  
 Moscow Psychoanalytic Society, 1520,  
   1543, 1881  
 Mose (Szondi), 1722  
 Moser-van Sulzer-Wart, Fanny Louise,  
   **1076–1077**  
   *See also* “Emmy von N.” case  
 Moses, 1595  
 Moses (Michelangelo), 107, 985, 1079, 1842  
 Moses, Raphael, 877  
*Moses and Monotheism* (Freud), **1077–1079**  
   anthropology and, 93  
   applied psychoanalysis and, 107, 108  
   on castration complex, 251  
   collective psychology and, 311  
   on complemental series, 318  
   on compromise formations, 321  
   on cultural transmission, 357  
   definition of psychoanalysis and, 1365  
   on ethics, 525–526  
   on femininity, 574  
   on historical truth, 749–750  
   on history, 750  
   *Imago* and, 802  
   Judaism and, 899–900  
   Loewenstein on, 291  
   on mnemonic traces, 1064  
   on myth of origins, 1321  
   mythology and, 1096  
   on negation, 1123  
   on politics, 1293  
   on primitive, 1319  
   on psychic causality, 1354  
   publication of, 641  
   on racism/anti-Semitism, 1438  
   on repression, 1491, 1492  
   sexuation and, 1595  
   sociology and, 1632  
   on superego, 1690  
   on taboo, 1723  
   on totemism, 1769  
   on visual, 1840  
   Zweig, Arnold and, 1890  
 Moses-Hrushevski, Rina, 877  
 “Moses of Michelangelo, The” (Freud), 985,  
   **1079**, 1842  
*Most Dangerous Game, The* (film), 294  
 Mother  
   abandonment and, 2–3  
   Ajase complex and, 39, 922  
   alcoholism and, 41  
   allergies and, 48  
   *amae* and, 56  
   anal-sadistic stage and, 73  
   anality and, 72  
   anxiety and, 99, 102  
   archaic, 112–113  
   capacity to be alone and, 247  
   counter-Oedipus and, 349  
   dead mother complex, 368–369  
   female sexuality and, 571, 573, 574  
   feminist views of psychoanalysis and,  
     577, 578  
   good-enough mother, 546, 688  
   jouissance and, 895  
   masculine protest and, 1019  
   maternal care and, 1028–1030  
   myth of origins and, 552  
   perversion and, 1255  
   phallic, 573, 1261–1262, 1263–1264  
   projective identification and, 51, 52,  
     121, 306  
   as prostitute, 342  
   *See also* Breastfeeding; Mother-infant bond;  
     Object relations; Oedipus complex  
 Mother goddess, **1079–1080**  
 Mother-infant bond  
   affect and, 1176  
   Bowlby on, 211–212  
   Brunswick on, 232–233  
   Burrow on, 237  
   censoring the lover in her and, 262  
   certainty and, 266  
   children’s play and, 283  
   clinging instinct and, 307  
   deprivation and, 397  
   ego and, 476  
   ego damage and, 475  
   ethology and, 528  
   false self and, 546  
   father and, 1346  
   good-enough mother and, 546, 688  
   handling and, 724–725, 843  
   holding and, 369, 607, 754, 843, 1582  
   *I* and, 775  
   illusion and, 797–798



## INDEX

Volume 1, pp. 1–662; Volume 2, pp. 663–1344; Volume 3, pp. 1345–1892

- individuation and, 811  
*infans* stage and, 812–814  
 infant observation and, 818  
 lover's censure and, 1170  
 maternal care and, 1028–1030  
 narcissism and, 1107  
 object and, 1170, 1171  
 object relations and, 843  
 passion and, 1244  
 postnatal depression and, 1297  
 primary love and, 1315  
 Rank on, 232  
 reverie and, 52, 127–128, 1030–1031, 1169, 1317, 1340  
 sense/nonsense and, 1584  
 skin-ego and, 1613  
 thought-thinking apparatus and, 1750  
 transference and, 1144  
 weaning and, 1851  
 Winnicott on, 1862  
 Zetzel-Rosenberg on, 1887–1888  
*See also* Breast; Breastfeeding; Symbiosis
- Motherhood, 1237, 1851  
*See also* Breastfeeding; Mother-infant bond; Parenthood  
*Motherhood and Sexuality* (Langer), 941  
 “Motives of Paranoiac Crime” (Lacan), 929  
*Mots et les choses, Les* (Foucault), 459  
 Mouchet, Enrique, 116  
 Mounier, Emmanuel, 363  
 Mourning, **1080–1082**  
 abandonment and, 2, 3  
 acting out and, 11  
 adolescence and, 28, 29  
 Certeau on, 266–267  
 cocaine addiction and, 308  
 coprophilia and, 346  
 dead mother complex and, 368–369  
 depression and, 394, 1081  
 dreams of, **1083**  
 internal objects and, 849–850  
 melancholia and, 21, 394, 1037–1038  
 “On Transience” on, 1195–1196  
 oral-sadistic stage and, 1203  
 Racamier on, 1436  
 self-object and, 1574  
 vs. separation, 3  
 time and, 1757  
 transmuted internalization and, 1798  
 war casualties and, 697  
 wish for a baby and, 1864  
 Wolfenstein on, 1870  
 work of the negative and, 1129  
*See also* Mourning disorder  
 “Mourning and Its Relation to Manic States” (Klein), 850, 994  
 “Mourning and Melancholia” (Freud), **1082–1083**  
 on abandonment, 3  
 on anal eroticism, 514  
 on anality, 72  
 on cultural transmission, 357  
 on decathexis, 374  
 on depression, 394  
 on ego ideal, 1106  
 on identification, 787–788  
 internal objects and, 849–850  
 on introjection, 869  
 on mania, 1006, 1007  
 on melancholia, 21, 1037, 1038  
 on memories, 1041  
 on mourning, 1080  
 on narcissistic withdrawal, 1116  
 on object loss, 994  
 on oral eroticism, 516  
 on orality, 1202  
 on pain, 1281  
 Schreber case and, 1546  
 on secondary narcissism, 1111  
 on self-hatred, 1571  
 on Shakespeare, 1598  
 on suffering, 1684  
 on work, 1876
- Mourning disorder, 6–7  
 Moury, Raoul, 426  
 “Mouth, Hand and Ego-Integration” (Hoffer), 752  
 Mouvement du coût Freudien, 612, 1084  
 Mouvement Freudien Internationale, 880  
*Mouvements individuels de vie et de mort, Les* (Marty), 421, 523, 1016  
*Mr. Deeds Goes to Town* (film), 292  
 “M[ ]re et l'enfant dans les psychoses du postpartum” (Racamier), 1422  
 “Mrs. C” case, 1532  
 Müller, Christian, 1557, 1701  
 Müller, F. von, 198  
 Müller-Braunschweig, Carl, **1084–1085**  
 Abraham, Karl and, 5  
 Berliner Psychoanalytische Poliklinik and, 675  
 German psychoanalysis and, 677  
 Göring Institute and, 406, 676, 1085  
 Karl Abraham Institute and, 166  
 Kemper, Werner Walther and, 910  
 Kemper and, 214  
 Nazi Germany and, 406, 675, 676, 689, 1085  
 Schultz-Hencke and, 1547  
 splits in psychoanalysis and, 1644  
 Multi-referential analysis, 603  
 Multidisciplinary interactions, **108–109**, 300–301, 309  
 Multilingualism, **1085–1086**  
 Multiple personalities, 1646  
 Miltzer, D., 1330  
 Mulvey, Laura, 294, 295  
 Munier, Alexandre, 1629  
 Munro, Lois, 131  
 Münsterberg, Hugo, 295  
 Münsterberger, Werner, 1510  
 Murder of the father. *See* Myth of origins; Parricide  
 Murray, Henry A., 511, **1087**, 1395, 1445  
 Murray, Jessie, 684, 685, 1599  
 Musatti, Cesare, **1087–1088**  
 Italian psychoanalysis and, 878, 880, 881, 1088, 1199, 1800  
*Rivista di psicoanalisi* and, 1508  
 Servadio and, 1586  
 Tomasi and, 1758
- Music, **1088–1089**  
 Deutsch and, 404  
 nostalgia and, 1159  
 Walter and, 1847  
 Mussolini, Benito, 879  
 Mutative interpretation, **1089–1090**  
 Muthmann, Arthur, 674  
 Mutilation. *See* Self-mutilation  
 Mutism, 1852  
 Mutual analysis, 581, **1090–1091**  
 M'Uzan, Michel de  
 on allergies, 48  
 Bouvet and, 211  
 Gressot and, 703  
*Inconscient, L'* and, 807  
 on latent dream thoughts, 947  
 Marty and, 1016  
 on operational thinking, 1198  
 on psychosomatics, 610, 1407, 1409  
*Revue française de psychanalyse* and, 1499  
 Videman and, 1835  
*My Analysis with Freud* (Kardiner), 907  
*My Farewell from the Yellow House* (Hollós), 765  
 “My Relationship with Psychoanalysis” (Mann), 1009  
 Myers, Frederick W. H.

Volume 1, pp. 1–662; Volume 2, pp. 663–1344; Volume 3, pp. 1345–1892

- British psychoanalysis and, 695  
 Flournoy, Théodore and, 592  
 Flügel and, 593  
*Studies on Hysteria* and, 1670  
 on subconscious, 1672  
 on telepathy, 1181  
 Myers-Briggs Type Indicator (MBTI), 1396  
 Mynard, Jacques, 327  
*Mysteries of a Soul, The. See Secrets of a Soul, The*  
*Mysterium Conjunctionis* (Jung), 902  
 Mystic writing pad, 1042, 1158–1159, 1613, 1757  
 Mysticism, **1091**  
 anagogical interpretation and, 71  
 Freud-Jung split and, 1643  
 jouissance and, 895–896  
 oceanic feeling and, 1091, 1181  
 paranoia and, 1230  
 Rolland on, 1511  
 Silberer and, 1608  
 Myth of origins, **1091–1093**, 1238, 1279–1280, 1321–1322  
 castration complex and, 251  
 dipsomania and, 413  
 Dostoyevsky and, 431–432  
 family and, 547  
 fantasy and, 552  
 father complex and, 557  
 Ferenczi and, 1739  
*Group Psychology and the Analysis of the Ego* on, 712, 713, 1321  
 identification and, 789  
 Oedipus complex and, 1184, 1322  
 ontogenesis and, 1197  
 organic repression and, 1207, 1208  
 otherness and, 1214  
 phylogenesis and, 1278  
 racism/anti-Semitism and, 1438  
 superego and, 1690  
 taboo and, 1723  
 totemism and, 1768  
 transgression and, 1792  
 Wednesday Society and, 667  
*See also* Parricide; Phylogenesis  
*Myth of the Birth of the Hero, The* (Rank), 185, 1077, **1093–1094**  
 Myth of the hero, **1094–1095**  
 “Myth of the Unconscious Mind, The” (Shaw-Bolton), 696  
 “Mythe de l’antipsychanalyse, Le” (Politzer), 1294  
 “Mythical Representations of the Anima, The” (Jung-Rauschenbach), 903–904  
 Mythology, **1095–1098**, **1099–1100**  
 archaic mother and, 113  
 archetypes and, 115  
 Arlow on, 120  
 bisexuality and, 186  
 death and, 370  
 Deleuze/Guattari on, 98  
 double and, 435  
 dream interpretation and, 865  
 dreams and, 443, 1099  
 femininity and, 573  
 Freud on, 107, 1095–1097, 1099, 1739–1740  
 Greek psychoanalysis and, 701  
 hero and, 1094–1095  
 heroic identification and, 739  
 latent dream thoughts and, 947  
 literature and, 986  
 pregnancy fantasy and, 1303  
 primal fantasies and, 1096, 1308  
 psyche and, 1348  
 Rank on, 443, 1093–1094, 1095  
 reversal into the opposite and, 1495  
 theme of three in, 1739–1740  
 typical dreams and, 1811  
 Mythomania, **1098–1099**  
**N**  
 Nabokov, Vladimir, 493  
 Nachin, Claude, 846, 1266  
 Nacht, Sacha Emanol, **1101–1103**  
 Aubry Weiss and, 128  
 Belgian psychoanalysis and, 157  
 Bonaparte and, 200  
 Bouvet and, 210  
 CCTP and, 264  
 Cénac and, 261  
 Centre de diagnostic et de traitements psychanalytiques and, 609–610  
 Claude and, 305, 1101  
 Congrès des psychanalystes de langue française des pays romans and, 330–331  
 on cure, 359  
 on death instinct, 372  
 Diatkine and, 410, 1102  
 Favez and, 560  
 Favreau and, 561, 1102  
 Ferenczi and, 328, 1103  
 French psychoanalysis and, 608, 609–610  
 French psychoanalytic establishment split (1953) and, 560, 609, 929, 1102, 1644  
 Held and, 731, 1102  
 on indications/contraindications for psychoanalysis, 809  
 Institut de psychanalyse de Paris and, 609, 955, 1004  
 on lay analysis, 951  
 Lebovici and, 954, 1102  
 Loewenstein and, 989, 1101, 1103  
 Marty and, 1016  
 Nazi Germany and, 1557–1558  
 on neutrality, 1144  
 Nodet and, 1152  
 on psychogenesis, 610  
 Racamier and, 1102, 1435  
 Schlumberger and, 1541  
 Société française de psychanalyse and, 1618  
 Société psychanalytique de Paris and, 1101, 1102, 1624, 1625–1626, 1629, 1630  
 on tact, 1725  
 on termination of treatment, 1737, 1738  
 on training analysis, 1770  
 Viderman and, 1834–1835  
*Nachträglichkeit. See* Deferred action  
 Näcke, Paul, 1105, 1190, 1525  
 Næsgaard, Sigurd, 390, 391, 1698  
 Nagler, Shmuel, 877  
*Naissance du psychanalyse, de Mesmer à Freud* (Chertok and Saussure), 277  
 Nakedness dreams, **1103–1104**, 1810  
 Name-of-the-Father, **1104**  
 fatherhood and, 558  
 foreclosure and, 595–596, 1487  
 imaginary identification/symbolic identification and, 798  
 infantile psychosis and, 826  
 metaphor and, 1048  
 metonymy and, 1050  
 myth of origins and, 1092  
 parade of signifiers and, 1225  
 phobias and, 1275  
 psychoses, 1404  
 Real, Symbolic, and Imaginary father and, 1452  
 Real and, 1453  
 signifier/signified and, 1607  
 signifying chain and, 1607  
 Nameless dread, 90  
 Namnun, Alfredo, 1051  
 Nancy, Jean-Luc, 241, 327, 1271  
 Nancy school, 144, 170, 1685  
 Nannun, Alfredo, 1833  
 Napoleon Bonaparte, 795, 1402  
 Narcissism, **1104–1109**

## INDEX

Volume 1, pp. 1–662; Volume 2, pp. 663–1344; Volume 3, pp. 1345–1892

- abandonment and, 2–3  
 action-thought and, 13, 14  
 activity/passivity and, 17  
 adolescence and, 29, 30  
 aggression and, 34  
 alcoholism and, 41  
 allergies and, 48  
 alter ego and, 52  
 anality and, 73  
 Andreas-Salomé on, 84, 1106, 1107  
 animus/anima and, 87  
 antinarcissism and, 97, 1114  
 Balint on, 97, 148–149, 151, 1111  
 bipolar self and, 185  
 borderline conditions and, 202, 203  
 cathexis and, 260  
 character and, 271  
 civilization and, 299  
 creativity and, 14  
 cruelty and, 355  
 dead mother complex and, 369  
 delusions and, 386  
 dependence and, 392  
 depersonalization and, 393  
 depression and, 394  
 deprivation and, 397  
 desexualization and, 399  
 dipsomania and, 413  
 disavowal and, 416–417  
 disintegration products and, 419  
 double and, 429, 434–435  
 ego and, 463, 465  
 ego ideal and, 479  
 ego-instincts and, 483  
 ego interests and, 484  
 erotogenic zones and, 519  
 ethics and, 526  
 fetishism and, 583  
 fragmentation and, 605  
 free energy/bound energy and, 617–618  
 gifts and, 682  
 grandiose self and, 691  
 guilt and, 717  
 heroic self and, 740  
 homosexuality and, 757  
 Horney-Danielson on, 1141  
 humor and, 762, 763  
 ideal ego and, 481  
 idealized parental imago and, 784  
 idealizing transference and, 785  
 identification and, 788, 1105, 1107, 1111  
 identity and, 795, 1324  
 infantile neurosis and, 821  
 infantile omnipotence and, 822, 1106  
 introjection and, 869–870  
 Kohut on, 278–279  
 Lampl-de Groot on, 938–939  
 magical thinking and, 1000  
 megalomania and, 1036  
 monism and, 1070  
 narcissistic injury and, 1112–1113  
 narcissistic withdrawal, 1116–1117  
 object-choice and, 70, 1105–1106, 1175  
 object relations and, 1107, 1171  
 oceanic feeling and, 296  
 omnipotence of thoughts and, 1189  
 oral stage and, 1205  
 paranoia and, 1228  
 paranoid-schizoid position and, 1233  
 patient physical position and, 541  
 penis envy and, 570  
 pleasure in thinking and, 1289  
 psychoanalytic nosography and, 1375  
 puberty and, 1420  
 racism/anti-Semitism and, 1438  
 reverie and, 555  
 rituals and, 1504  
 Róheim on, 1510  
 Rosenfeld, Herbert on, 1106–1107, 1515  
 Sadger on, 1525  
 sadism and, 1526  
 secondary, **1110–1111**  
 self and, 1580  
 self-image and, 1571  
 self-mutilation and, 1573  
 self-object and, 1574  
 self-preservation and, 1674  
 self psychology on, 1576  
 silence and, 1611  
 skin and, 1612  
 sleep/wakefulness and, 1614  
 social feeling and, 1618  
 stages and, 1652  
 state of being in love and, 1656  
 subject of the unconscious and, 1675  
 sublimation and, 1679  
 suicide and, 1686  
 superego and, 1691  
 symbiosis and, 1706  
 taboo and, 1724  
 tics and, 1756  
 transference hatred and, 1782  
 transsexualism and, 1799  
 trauma and, 1801–1802  
 twinship transference and, 1810  
 ulcerative colitis and, 1813  
 visual and, 1840–1841  
 wish for a baby and, 1864  
 work of the negative and, 1130  
*See also* Primary narcissism  
*Narcissism: Psychoanalytic Essays* (Grunberger), 33  
 “Narcissism in the Structure of the Ego” (Federn), 568  
 Narcissism of minor differences, **1109–1110**  
 Narcissistic defenses, **1111–1112**  
 Narcissistic elation, **1112**  
 “Narcissistic Evaluation of Excretory Processes in Dreams and Neuroses, The” (Abraham), 517  
 Narcissistic injury, **1112–1113**, 1114  
 Narcissistic neuroses, 21, 464, **1113–1114**, 1139  
 Narcissistic personality disorders, 2, 1117  
 Narcissistic rage, 1113, **1114–1115**, 1228  
 Narcissistic transference, **1115–1116**  
 idealizing transference and, 785  
 Kohut on, 920, 1115–1116  
 self-object and, 1574  
 self psychology on, 1576  
 twinship transference and, 1810  
 Narcissistic withdrawal, **1116–1117**  
 Narcissus, 27, 429, 1096, 1112  
 Narco-analysis, **1117–1118**  
 Narjani, A. E.. *See* Bonaparte, Marie Léon  
*Narrative of a Child Analysis* (Klein), 1501  
*Narzissmus als Doppelrichtung* (Andreas-Salomé), 84  
 Nasio, Nelba, 428  
 Natahi, Okba, 1156  
 Nathan, Tobie, 527, 1775  
 National Association for the Welfare of Children in Hospital, 1509  
 National Psychological Association for Psychoanalysis (NPAP), **1118**, 1146, 1644  
 “Nature and Function of Phantasy, The” (Isaacs), 873–874  
 “Nature of the Child’s Tie to his Mother, The” (Bowlby), 212  
 “Nature of the Therapeutic Action of Psycho-Analysis, The” (Strachey), 1663  
*Naturphilosophie*, 673, 674, 686  
*Nazi Doctors, The* (Lifton), 1393  
 Nazi Germany, 1557–1558  
 AÄGP and, 49  
 analytical psychology and, 79  
 anti-Semitism and, 1437, 1438  
 Aubrey Weiss and, 128

Volume 1, pp. 1–662; Volume 2, pp. 663–1344; Volume 3, pp. 1345–1892

- Austrian psychoanalysis and, 133, 135, 1858  
 Belgian psychoanalysis and, 157  
 Berliner Psychoanalytische Poliklinik and, 164  
 Berliner Psychoanalytisches Institut and, 166  
 Bernfeld and, 169  
 Bettelheim and, 172, 173  
 Bibring and, 176  
 Bibring-Lehner and, 177  
 Bjerre on, 189  
 Blois and, 196  
 Boehm and, 164, 198, 199, 406, 675, 676, 689, 852  
 Bonaparte and, 200  
 Boston Psychoanalytic Society/Institute and, 207  
 British psychoanalysis and, 228, 343, 697  
 Burlingham and, 236  
 Caruso and, 248  
 Chertok and, 276  
 Claude and, 305  
 Czech psychoanalysis and, 361  
 Delay and, 382  
 Dutch psychoanalysis and, 1133, 1200  
 Erikson on, 282  
 Fenichel and, 579  
 former Yugoslavian psychoanalysis and, 1884  
 French psychoanalysis and, 608  
 Freud, Anna and, 619  
 Freud family escape from, 133, 235, 343, 608, 621, 622, 626, 631, 641, 893, 899  
 Freud's Gestapo comment and, 681–682  
 Freud's views on Judaism and, 899–900  
 Friedländer-Fränk and, 646  
 Friedländer on, 750  
 Gardiner and, 664  
 German psychoanalysis and, 675–676, 679, 852, 1602  
 Göring and, 689  
 Göring Institute and, 406  
 Groddeck and, 705  
 Happel and, 725  
 Hartmann and, 727  
 H.D. and, 430  
 Held and, 731  
 Hellman Noach and, 734  
 Hilferding-Hönigsberg and, 746  
 history and, 750  
 Hirschmann and, 752  
 Hollós and, 756  
 Hungarian psychoanalysis and, 766  
 Hungarian School and, 764  
 International Psychoanalytical Association and, 856, 858  
*Internationale Zeitschrift für Psychoanalyse* and, 860–861  
 Internationaler Psychoanalytischer Verlag and, 801, 803, 862  
 Isakower and, 874  
 Jacobson and, 676, 883  
 Japanese psychoanalysis and, 887  
 Jones and, 893  
 Jung and, 902  
 Katan-Rosenberg and, 908  
 Kemper, Werner Walther and, 910  
 Kohut and, 919  
 Kraus and, 923  
 Kris and, 924  
 Kris-Rie and, 925  
 Laforgue and, 934, 963, 1401, 1625  
 Lampl and, 939  
 Lampl-de Groot and, 938  
 Landauer and, 940  
 Lebovici and, 954  
 Lehrinstitut der Wiener psychoanalytischen Vereinigung and, 959  
 Loewenstein on, 291  
 Mahler-Schönberger and, 1001  
 Mann on, 1009  
 Marcuse and, 1013  
 Menninger and, 1045  
 Mexican psychoanalysis and, 1051  
 Mitscherlich and, 1060–1061  
 Money-Kyrle on, 1070  
 Morgenstern-Kabatschnik and, 1073  
 Müller-Braunschweig and, 406, 675, 676, 689, 1085  
 New York Psychoanalytic Institute/Society and, 1148  
 Norwegian psychoanalysis and, 1157  
 Pappenheim and, 1224  
*Psyche* and, 1351  
 psychohistory and, 1393  
*Psychoanalytische Bewegung, Die* and, 1387–1388  
 Reich and, 675–676, 1018, 1022–1023, 1461  
 Reik and, 1463  
 Rickman and, 1501–1502  
 Rittmeister and, 1505, 1506  
 Rolland and, 1511  
 Romanian psychoanalysis and, 1511  
 Sadger and, 1524, 1525  
 Sainte-anne Hospital and, 1528  
 Saussure, Raymond de and, 1536  
 Schultz-Hencke and, 406, 676, 852, 1547  
 Secret Committee and, 1562  
 Simmel and, 1611  
 Société psychanalytique de Paris and, 1624–1625  
 Sokolnicka-Kutner and, 1633  
 Spielrein and, 1518, 1639  
 splits in psychoanalysis and, 1644  
 Sterba and, 172, 1659  
*Studienausgabe*, 1670  
 Swedish psychoanalysis and, 1699  
 Szondi and, 1721  
 U.S. psychoanalysis and, 1529, 1824  
 Viderman and, 1834  
 Wiener psychoanalytische Vereinigung and, 1857–1858  
 Winterstein and, 1858, 1863  
 Zweig, Arnold and, 1889  
 Zweig, Stefan and, 1891  
 Nederlandsche vereeniging voor psychoanalyse, 498, 1132–1133, 1200  
 Need for causality, **1118–1120**  
 Need for punishment, 37, 38, **1120–1121**, 1126, 1577–1578  
 Needs, 1575  
 Negation, **1121–1122**, 1122–1123  
 binding/unbinding and, 180  
 contradiction and, 341  
 defenses and, 375  
 myth of origins and, 1093  
 work of the negative and, 1129  
 “Negation” (Freud), **1122–1123**  
 on binding/unbinding, 180, 219  
 on death instinct, 372  
 on ego, 465  
 on experience of satisfaction, 536  
 on femininity, 573  
 on hatred, 729  
 on infant development, 814  
 on internal/external reality, 847  
 on myth of origins, 1092  
 on negation, 1121  
 on phobias, 1275  
 on primal, 1286  
 publication of, 641  
 on purified-pleasure-ego, 1423  
 Real and, 1453  
 on representation, 782  
 on reversal into the opposite, 1495  
 on Shakespeare, 1598  
 on Thing, 1743

## INDEX

Volume 1, pp. 1–662; Volume 2, pp. 663–1344; Volume 3, pp. 1345–1892

- on thought, 1746  
 on work of the negative, 1129  
 on working-through, 1880  
 Negative, work of, **1129–1130**, 1560, 1822, 1876  
 Negative capability, **1123–1124**  
 Negative hallucination, **1124–1125**, 1130, 1477  
 Negative therapeutic reaction, **1125–1127**, 1469–1470  
 cure and, 359  
 pain and, 1219  
 self-punishment and, 1577  
 transference hatred and, 1782  
 work of the negative and, 1130  
 Negative transference, 77, **1127–1129**, 1777, 1781–1782  
 Nel-Dumouchel, Colette, 45, 46  
 Nelson, Marie Colemand, 1380  
 Nemes, Livia, 766  
 Neo-catharsis, 1464–1465  
 Neo-Freudian movement, 651  
*Neopsychanalyse* (Schultz-Hencke), 1131  
 Neopsychoanalysis, **1130–1131**, 1547  
 German psychoanalysis and, 676, 677, 678, 679  
 individual psychology and, 26  
 Müller-Braunschweig and, 1085  
 Neosexualities, 1256, 1259  
 Neri, Claudio, 709–710  
*Nervous Anxiety States and their Treatment* (Stekel), **1131–1132**  
 Netherlands. *See* Dutch psychoanalysis  
*Neue Quellen* (Andreas-Salomé), 83  
 Neumann, Ernst, 79  
 Neurasthenia, 19, 306, 1135, **1135**, 1822  
 “Neurasthenia and ‘Anxiety Neurosis’”. *See* “Detaching a Syndrome of Anxiety Neurosis from Neurasthenia”  
 Neuro-psychoses of defense, **1138**  
 “Neuro-Psychoses of Defense, The” (Freud), 19, 1138, 1646  
 on conversion, 345  
 on decathexis, 374  
 on defense mechanisms, 376  
 on ego, 461–462  
 on excitation, 533  
 on guilt, 716, 717  
 on isolation, 875  
 on mnemonic symbols, 1061  
 on obsessional neurosis, 1179  
 on phobic neurosis, 1276  
 on psychoses, 1404  
 on psychotic defenses, 1413  
 on quantitative/qualitative dimensions, 1427  
 on repression, 1483, 1485  
*Studies on Hysteria* and, 1671  
 on substitute formations, 1680, 1681  
 Neurobiology, 59, 1064  
 Neurophysiology  
 archetypes and, 115  
 automatism and, 143  
 brain, 212–213  
 British psychoanalysis and, 695  
 Brücke and, 231  
 facilitation and, 542–543  
 Meynert on, 1054  
 mnemonic traces and, 1062  
 nonverbal communication and, 1153  
 U.S. psychoanalysis and, 59  
 Neuroses, **1138–1140**  
 actual vs. defense, 19–20, 231, 326, 345, 420, 1138–1139  
 anal-sadistic stage and, 74  
 anxiety, 19, 420, 1135–1137, 1681  
 autoplasmic behavior and, 144  
 Bergler on, 152–153, 163  
 body image and, 197  
 change and, 268  
 character and, 271, 273–274  
 Charcot on, 287, 735  
 choice of neurosis, 287–289, 345, 435  
 civilization and, 299  
 complementary series and, 318  
 complexes and, 319  
 as developmental disorders, 408  
 encopresis and, 504  
 Eros and, 512  
 erotogenic zones and, 518  
 ethics and, 525  
 fate neurosis, 544, 556–557  
 flight into illness and, 590  
 forgetting and, 596  
 gaze and, 990  
 Horney-Danielson on, 759  
 incompleteness and, 805  
 infantile, 75–76, 820–821, 1140  
 inferiority feelings and, 832  
 introjection and, 869, 871  
 mnemonic traces and, 1063  
 narcissistic, 21, 464, 1113–1114, 1139  
 neuro-psychoses of defense and, 1138  
 neurotica, 1142–1143  
 omnipotence of thoughts and, 1189  
 Other and, 1213  
 perversion and, 326, 1255  
 phobic, 19, 306, 1276  
 process and, 1328  
 psychosis/neurosis distinction, 1414–1416  
 rationalization and, 1448  
 representation and, 781  
 seduction theory and, 669–670, 735, 1142–1143  
 self psychology on, 1576  
 symptoms and, 1715  
 trauma and, 1801  
*See also* Obsessional neurosis; Traumatic neuroses  
*Neurosis and Human Growth* (Horney), 759, **1140–1141**  
 “Neurosis and Psychosis” (Freud), 21, 22, 465, 1048, 1139, 1234  
*Neurotic Constitution, The* (Adler), 25, 831, 832  
 Neurotic defenses, **1141–1142**  
 “Neurotic Mechanisms in Jealousy, Paranoia, and Homosexuality” (Freud). *See* “Some Neurotic Mechanisms in Jealousy, Paranoia, and Homosexuality”  
*Neurotic Personality of Our Time, The* (Horney), 759  
 Neurotica, **1142–1143**  
*See also* Seduction theory  
 Neutrality, 339, 531, **1143–1144**  
 Neutralization, 473  
*Névrose d’abandon, La* (Guex), 2, 715  
 “Névrose de caractère et mentalisation” (Fain), 270, 274  
*Névroses de guerre et Traumatisme psychique* (Simmel), 586  
*Névroses de Idées fixes* (Janet), 886  
*New Fields of Psychoanalysis* (Levy), 1825  
*New Foundations for Psychoanalysis* (Laplanche), 1566  
*New German-English Psychoanalytical Vocabulary, A* (Strachey), 1654, 1664  
*New Introductory Lectures on Psychoanalysis* (Freud), **1144–1146**  
 on ambivalence, 57  
 on anality, 72  
 on anxiety, 563  
 on anxiety dreams, 103  
 on automatism, 143  
 on castration complex, 254  
 on change, 268  
 on character, 269, 273  
 on cultural transmission, 357  
 on culture, 641

Volume 1, pp. 1–662; Volume 2, pp. 663–1344; Volume 3, pp. 1345–1892

- on death instinct, 372  
 on ego, 466  
 on ego ideal, 479, 1106  
 on ego-instincts, 483  
 on feces, 564  
 on female sexuality, 571, 1753  
 Hirschfeld, Elfriede and, 747  
 on identification, 789  
 on incompleteness, 805–806  
 on instinctual impulse, 840  
 on intergenerational phenomena, 845  
 Kosawa and, 922  
 on Marxism, 1017  
 on masculinity/femininity, 572, 1019  
 on orality, 1202  
 on phallic mother, 1263  
 on politics, 1293  
 on psychic apparatus, 1351, 1352  
 on psychic causality, 1354  
 on psychic structure, 1358–1359  
 on punishment dreams, 1422  
 on repetition compulsion, 1475  
 on repression, 1479, 1487, 1491  
 on subject, 1673  
 on telepathy, 1735  
 on *Weltanschauung*, 1146, 1854  
 on wish-fulfillment, 1865  
*New Language for Psychoanalysis, A* (Schafer), 13  
*New Ways in Psychoanalysis* (Horney), 759  
*New Ways to the Understanding of Youth* (Hug-Hellmuth), 762  
 New York Freudian Society, **1146–1147**  
 New York Psychoanalytic Institute/Society, **1147–1148**  
 American Academy of Psychoanalysis and, 58  
 American Psychoanalytic Association and, 61  
 Bak and, 146  
 Brill and, 227, 1147  
 Eissler-Selke and, 492  
 Geleerd and, 668  
 Greenacre and, 702  
 Hartmann and, 728  
 Horney and, 1644  
 Horney-Danielson and, 1558, 1824  
 Isakower and, 874  
 Kardiner and, 906  
 Lehrman and, 960  
 Loewenstein and, 988  
 Lorand and, 991  
 Radó and, 1441  
 Reich, Annie and, 1461  
 Reik and, 1463  
 Saussure, Raymond de and, 1536  
 Schilder and, 1538  
 Schur and, 1548  
 Stone and, 1661  
 U.S. psychoanalysis and, 1823, 1824  
 Wittels and, 1869  
 Neyraut, Michel  
*Confrontation* and, 327  
*Inconscient, L'* and, 807  
 on logic, 990  
 Martinican psychoanalysis and, 1014  
 on mythomania, 1098  
 Société psychanalytique de Paris and, 1628  
 on transference, 422–423  
 Viderman and, 1835, 1836  
 Neyraut-Suttermann, Marie-Thérèse, 48  
 Nicolaïdis, Graziella, 1096, 1097, 1701  
 Nicolaïdis, Nicos, 372–373, 1096, 1097, 1701  
 Nicoll, Morris, 1457  
 Niederland, William G., 1060, 1546  
 Nield, Janet, 131, 132  
 Nielsen, Nils, 391  
 Nieto, Marta, 1829  
 Nietzsche, Friedrich, 1271  
 Andreas-Salomé and, 83  
 on civilization, 298  
 cryptomnesia and, 356  
 Groddeck and, 705  
 Groddeck on, 201  
 Gross and, 707  
 id and, 777  
 on individuation, 811  
 philosophy and, 1270  
 on self-consciousness, 1569  
 Zweig, Arnold and, 1889–1890  
 Night terrors, **1149**, 1231, 1636  
*Nightmare Alley* (film), 293  
 Nightmares, 102–103, **1149–1150**  
 Nihilism, 1855  
 Nikolic, S., 1884  
 Nin, Anaïs, 46, **1150–1151**, 1443  
*1984* (Orwell), 111  
*Nineteen-Nineteen* (film), 293, 294  
 Nipple. *See* Breast as good/bad object; Breastfeeding; Sucking  
 Nirvana principle, **1151–1152**, 1325  
 constancy principle and, 1151, 1323  
 death instinct and, 371, 1151, 1152  
 desexualization and, 399  
 discharge and, 417  
 erotogenic masochism and, 517  
 excitation and, 534  
 pleasure principle and, 1151, 1291  
 protective shield and, 1341  
 quantitative/qualitative dimensions and, 1428  
 Nishizono, Masahisa, 887  
 Nitzschke, Bernd, 1608, 1751  
 Nizan, Paul, 37, 935  
*No and Yes: On the Genesis of Human Communication* (Spitz), 1641  
 Nocturnal enuresis, 1636  
 Nodet, Charles-Henri, 156, 305, **1152–1153**  
 Nodier, Charles, 1624  
 Noizet, Joseph, 85, 973  
 Nominalism, 1270  
 Non-rapid eye movement (NREM) sleep, 1614, 1636  
 Non-selectivity, 127, 250  
 Non-transmission, 1560  
 Nondelusional psychoses. *See* Blank psychoses  
 Nonidentity, 31  
 Nonintegration, 843–844  
 Nonsense, 1584–1585  
 Nonverbal communication, 152, **1153–1154**, 1732–1733  
 Nordisk Psychoanalytisk Samfund, 1698  
 Norell, Margit, 1699  
*Normality and Pathology in Childhood, Assessments of Development* (Anna Freud), 537, 619, 1387  
 North African psychoanalysis, **1154–1156**  
*North by Northwest* (film), 294  
 Norwegian psychoanalysis, **1156–1158**  
 Nosography. *See* Psychoanalytic nosography  
 Nostalgia, 3, 526, **1158–1159**  
 “Note on the Prehistory of the Technique of Analysis” (Freud), 356, 616  
 “Note on the Unconscious in Psycho-Analysis, A” (Freud), 1662  
 “Note upon the ‘Mystic Writing Pad’, A” (Freud), 1042, 1063–1064, **1159–1160**, 1340, 1819  
 “Notes on an unusual form of perversion” (Glover), 686  
 “Notes on Dream Interpretation” (Freud), 443  
 “Notes on Infant Observation in Psycho-Analytic Training” (Bick), 817, 818  
 “Notes on Some Schizoid Mechanisms” (Klein), 418  
 “Notes on Symbol Formation” (Segal), 1708

Volume 1, pp. 1–662; Volume 2, pp. 663–1344; Volume 3, pp. 1345–1892

- “Notes on the Psycho-Analytical Investigation and Treatment of Manic-Depressive Insanity and Allied Conditions” (Abraham), 21
- “Notes upon a Case of Obsessional Neurosis”. *See* “Rat Man” case
- Nothnagel, Hermann, 567, 843, 1837
- Nourrisson, la mère et le psychanalyste, Le* (Lebovici and Stoléru), 955
- Nousiainen, Tapio, 584
- “Nouveaux développements sur l'hallucination négative et la représentation” (Duparc), 1125
- Nouvelle Revue de psychanalyse*, 124, 611, 913, **1162–1163**, 1617
- Nouvelle Revue française*, 1634
- Noy, Pinchas, 877
- NPAP (National Psychological Association for Psychoanalysis), **1118**, 1146, 1644
- Nuclear complex, **1163–1164**  
*See also* Oedipus complex
- Nudity dreams. *See* Nakedness dreams
- Nuevos Aportaciones al psicoanálisis de los sueños* (Garma), 666
- Numinous, 115, **1164–1165**, 1165
- Nunberg, Hermann, **1165–1166**  
Argentinian psychoanalysis and, 117  
Bibring-Lehner and, 177  
Burghölzli Asylum and, 180  
on character, 273  
on depersonalization, 393  
on ego, 476–477  
ego psychology and, 476  
Federn, Paul and, 568  
Flournoy, Henri and, 591  
Foulkes and, 601  
on heroic self, 739  
Hoffer and, 752  
on ideal ego, 481  
Lehrinstitut der Wiener psychoanalytischen Vereinigung, 959  
photograph of, II:pl.28  
Polish psychoanalysis and, 1291  
Reich, Annie and, 1461  
Swiss psychoanalysis and, 1700, 1702  
on training analysis, 1769  
Vienna Ambulatorium and, 959  
Waelder and, 1845  
Wiener psychoanalytische Vereinigung and, 1857
- Nunes, Portella, 216
- Nuñez, Carlos, 284
- Nuovi orientamenti nella psicoanalisi* (Fornari), 598
- Nursing mother. *See* Breastfeeding  
*Nyugat*, 765
- O**
- Oberdorf, Clarence, 393
- Oberholzer, Emil, **1167–1168**  
Brun and, 231  
Burghölzli Asylum and, 236  
Pfister and, 1167, 1260  
Sarasin and, 1534  
Swiss psychoanalysis and, 1513, 1549, 1550, 1700, 1703
- Oberholzer, Mira, 1513, 1700
- Oberndorf, Clarence, 207–208
- Obholzer, Karin, 665
- Object, **1168–1172**  
anaclitic depression and, 70  
autoeroticism and, 141  
signifiers and, 1605  
splitting of, 1642, 1645, 1648–1649  
structuralism and, 1668  
*See also* Cathexis; Object-choice; Object loss; Object relations
- Object, change of, 1174–1175, 1185–1186, 1736  
*See also* Female sexuality; Penis envy
- Object, choice of. *See* Object-choice
- Object *a*, 323, 994, **1172–1174**
- Object-cathexis. *See* Cathexis
- Object-choice, 1168, **1174–1175**  
allergic object relationship and, 47  
anaclitic depression and, 70  
autoeroticism and, 141  
bisexuality and, 187, 1175  
character and, 269  
genital stage and, 672  
homosexuality and, 1389–1390  
love and, 994–995  
melancholia and, 1038  
narcissism and, 70, 1105–1106, 1175
- Object-libido. *See* Ego-libido/object-libido
- Object loss, **993–994**  
abandonment and, 2, 3  
acting out and, 11  
anality and, 72  
anorexia nervosa and, 91, 92  
anxiety and, 99, 101, 102  
autism and, 1809  
boredom and, 203  
breakdown and, 218  
cathexis and, 260  
decathexis and, 374  
depression and, 394  
deprivation and, 397  
ego and, 464  
fear and, 563  
feces and, 564  
guilt and, 716  
identification and, 787–788  
internal objects and, 849  
lack of being and, 1847–1848  
mastery and, 1023–1024  
maternal and, 1027  
megalomania and, 1036–1037  
melancholia and, 994, 1037–1038  
metonymy and, 1050  
mourning and, 21, 849  
orality and, 1202  
pain and, 1219, 1281  
subject's desire and, 1677  
Thing and, 1743  
trauma and, 1801–1802  
ulcerative colitis and, 1813  
work of the negative and, 1129  
*See also* Mourning
- Object phobias, 1273
- Object-presentations, 12
- Object-presenting, 843
- “Object Relation Theory of the Personality, An” (Fairbairn), 545
- Object relations  
aggression and, 34  
anal eroticism and, 515  
anorexia nervosa and, 92  
Bleger and, 194  
Bouvet on, 211, 1170  
British psychoanalysis and, 697  
conflict and, 326  
dead mother complex and, 369  
depersonalization and, 393  
depressive position and, 396  
ego and, 465, 467  
emotions and, 501  
family and, 547, 548  
feminist views of psychoanalysis and, 577  
Ferenczi on, 581  
genital love and, 671  
heroic self and, 740  
id and, 779  
infantile sexuality and, 1753–1754  
Kernberg on, 1171–1172  
masturbation and, 1026  
melancholia and, 1038  
mother-infant bond and, 843  
mourning and, 697

Volume 1, pp. 1–662; Volume 2, pp. 663–1344; Volume 3, pp. 1345–1892

- narcissism and, 1107, 1171  
 ontogenesis and, 1198  
 orality and, 1202  
 organization and, 1209  
 phobias and, 1275  
 primary love and, 1315  
 psychic causality and, 1354  
 quasi-independence/transitional stage and, 1429  
 tenderness and, 1736  
 thing-presentations and, 1743  
 transitional phenomena and, 1794, 1795, 1796  
 work of the negative and, 1130  
*Object Relations* (Lacan), 553, 1452, 1453  
 Object relations theory, **1175–1177**  
 antilibidinal ego and, 96  
 birth trauma and, 1803  
 change and, 268  
 drives and, 447, 1176, 1177  
 ego psychology and, 487  
 Fairbairn and, 546, 1176  
 feminist views of psychoanalysis and, 576  
 Japanese psychoanalysis and, 888  
 Kardiner and, 906  
 object *a* and, 1173  
*Psychoanalytic Study of the Child, The* and, 1382  
 Sandler and, 1176, 1533  
 subject's castration and, 1676  
 U.S. psychoanalysis and, 1826  
 Winnicott and, 1176, 1862  
 Objectalizing function, 1171  
*Obras Completas* (Freud) (Biblioteca Nueva de Madrid), 175  
 O'Brien, D., 131  
 "Observation of Infants in a Set Situation, The" (Winnicott), 688, 817  
*Observations and Analyses Drawn from Analytical Practice* (Freud), 1246  
 "Observations on Transference-Love" (Freud), 7, 350, 1244, 1785  
 Obsessional neurosis, 735, **1179–1180**  
 activity/passivity and, 16–17  
 anal-sadistic stage and, 74, 211  
 animistic thought and, 86  
 Bouvet on, 211  
 compromise formations and, 321  
 compulsion and, 323, 1180  
 coprophilia and, 346  
 death and, 370  
 as defense neurosis, 19  
 demand and, 388  
 as developmental disorder, 408  
 doubt and, 435  
 infantile psychosis and, 828  
 instinctual impulse and, 839  
 isolation and, 875–876  
 libido and, 969  
 melancholia and, 1037  
 neurotic defenses and, 1141–1142  
 omnipotence of thoughts and, 1189  
 phobias and, 1274  
 "Rat Man" case and, 821, 1178, 1179  
 religion and, 660  
 rituals and, 1503, 1504  
 sadomasochism and, 1527  
 seduction theory and, 1755  
 self-punishment and, 1577  
 substitute formations and, 1681  
 taboo and, 1724  
 turning around and, 1808  
 undoing and, 1180, 1821–1822  
 "Wolf Man" case and, 649  
 Obsessions, **1177–1179**  
 action vs. thought in, 18  
 compulsion and, 322, 1178  
 vs. delusions, 385  
 dismantling and, 419  
 doubt and, 435–436  
 psychic structure and, 1359  
 "Rat Man" case and, 1161  
*See also* Obsessional neurosis  
 "Obsessions and Phobias: Their Psychological Mechanism and Their Aetiology" (Freud), 322, 1274, 1680  
*Obsessions et les Impulsions, Les* (Pitres and Régis), 1272, 1459  
 "Obsessive Actions and Religious Practices" (Freud), 107, 311, 716, 717, 839, 1466, 1503, 1632, 1723  
 Obstructive object, 121  
 Occultism, 640, 1145, **1180–1181**, 1735  
 Oceanic feeling, 265, 296, 660, 899, **1181–1182**, 1511  
 Freud's self-analysis and, 425  
 jouissance and, 895  
 mysticism and, 1091, 1181  
 narcissism and, 296  
 Ochonisky, Jean, 1573  
 Ocnophilic behavior, 149  
 Odette, case of, 110–111  
 Odgen, Thomas, on self, 1568  
 Odier, Charles, **1182–1183**  
*Archives de psychologie, Les* and, 302  
 Baudouin and, 154  
 Cárcamo and, 117, 247  
 Congrès des psychanalystes de langue française des pays romans and, 329  
 Dubal and, 450  
 Flournoy, Henri and, 591  
 Gressot and, 703  
 Guex and, 715  
 Nodet and, 1152  
*Psyché* and, 1350  
*Revue française de psychanalyse* and, 1182, 1497, 1498  
 Saussure, Raymond de and, 1536  
 Sechehaye and, 1556  
 Société psychanalytique de Paris founding and, 608  
 Swiss psychoanalysis and, 1620, 1700, 1703  
 Oedipus, 27, 1093, 1393, 1712  
*See also* Oedipus complex  
*Oedipus and Hamlet* (Jones), 893  
*Oedipus and the Devil* (Roper), 1393  
 Oedipus complex, **1183–1187**, 1593, 1635  
 abandonment and, 2  
 Abraham, Nicolas on, 7  
 adolescence and, 26, 28, 29  
 aggression and, 34, 35  
 allergic object relationship and, 47  
 ambivalence and, 57  
 animus/anima and, 87  
 anthropology and, 93  
 anxiety and, 100, 101  
 archaic mother and, 112, 113  
 basic assumptions and, 151  
 biological bedrock and, 182  
 bisexuality and, 187  
 blank psychoses and, 191  
 borderline conditions and, 202  
 breast as good/bad object and, 219  
 castration anxiety and, 101  
 castration complex and, 252–253, 254  
 censoring the lover in her and, 262, 1174  
 Chinese psychoanalysis and, 285  
 claustrophobia and, 306  
 collective psychology and, 311  
 combined parent figure and, 316  
 conflict and, 326  
 counter-Oedipus and, 348–349  
 cultural transmission and, 357  
 cultural variations in, 59  
 dead mother complex and, 369  
 Deleuze/Guattari on, 98  
 depression and, 395  
 depressive position and, 396



## INDEX

Volume 1, pp. 1–662; Volume 2, pp. 663–1344; Volume 3, pp. 1345–1892

- Dolto-Marette on, 1347  
 dreams and, 438, 442  
 early, 113, 219, 915, 1174, **1187–1189**  
 encopresis and, 504  
 Eros and, 512–513  
 estrangement and, 524  
 ethnopsychanalysis and, 527  
 failure neurosis and, 544  
 family romance and, 548, 1494  
 fantasy and, 551  
 father complex and, 557  
 fatherhood and, 558  
 female sexuality and, 570, 571, 573, 576  
 feminist views of psychoanalysis and, 578  
 fetishism and, 583  
 Freud's self-analysis and, 425, 551  
 genital love and, 671  
 grid and, 704  
 guilt and, 353, 716–717  
 homosexuality and, 1390  
 idealization and, 783–784  
 identification and, 788, 789  
 imposter and, 803  
 incest and, 804  
 individual and, 810  
 infantile amnesia and, 819, 820  
 infantile and, 830  
 Kantianism and, 905  
 Korean psychoanalysis and, 921  
 L and R schemas and, 927–928  
 lack of being and, 1848  
 latency period and, 945, 946  
 Law of the Father and, 950  
 libidinal development and, 965  
 literature and, 986  
 “Little Hans” case and, 76, 1184, 1185, 1322  
 Malinowski on, 1005  
 Martinican psychoanalysis and, 1014  
 mother as prostitute and, 342  
 myth of origins and, 1184, 1322  
 mythology and, 1096, 1097  
 Name-of-the-Father and, 1104  
 neuroses and, 1138, 1139  
 ontogenesis and, 1197  
 paranoia and, 1227  
 parricide and, 1238, 1239  
 penis envy and, 1185, 1246  
 phallic stage and, 1262, 1263  
 phobias and, 1274  
 pregnancy fantasy and, 1302  
 primal, 1186  
 prohibition and, 1332  
 psychogenic blindness and, 1393  
 “Rat Man” case and, 1161, 1184  
 rescue fantasies and, 1487–1488  
 “Richard” case and, 1500–1501  
 rivalry and, 1506  
 sadomasochism and, 1527  
 secrets and, 1561  
 self psychology on, 1576  
 sense/nonsense and, 1584  
 sexual difference recognition and, 1588  
 Shakespeare and, 1597  
 signifiers and, 1605  
 sociology and, 1632  
 stages and, 1651  
 stammering and, 1653  
 Stoller on, 1660  
 subject's desire and, 1678  
 superego and, 471, 1690, 1691  
 symbolic and, 1710  
 symptoms and, 1718  
 totemism and, 1768  
 transference neuroses and, 1786  
 transgression and, 1792  
 unconscious fantasies and, 1817  
 violence instinct and, 1839  
 wish for a baby and, 1864  
 Oedipus conflict. *See* Oedipus complex  
*Oedipus Rex* (Sophocles), 1593  
*Oedipus the King* (Sophocles), 107, 985  
 Ogden, Thomas, 849, 850, 1339  
 Ohlmeier, Dieter, 1602  
 Okonogi, Keigo, 39, 887, 888  
 Olagaray, Jorge, 285  
 Olender, Maurice, 1628  
 Olfactory theory, 1207  
 Olivares, Juan Antonio, 1832  
 Oliveira, Walderedo Ismael de, 214, 215, 216, 217  
 Ombredane, André, 157  
 Omnipotence  
 borderline conditions and, 202–203  
 ideal ego and, 481  
 infantile, 822–823, 1106, 1189  
 megalomania and, 1036, 1037  
 transitional phenomena and, 1797  
 Omnipotence of thoughts, **1189–1190**  
 amplification and, 68  
 animistic thought and, 85, 86, 1189  
 projective identification and, 1339  
 rituals and, 1504  
 taboo and, 1724  
 thought and, 1748  
 uncanny and, 1815  
*On Adolescence: A Psychoanalytic Interpretation* (Blos), 196–197  
*On Aphasia* (Freud)  
 on attention, 127  
 Deuticke and, 403  
 on internal/external reality, 847  
 Jackson and, 539  
 on memory, 1042  
 on multilingualism, 1086  
 publication of, 802  
 on representation, 781  
 on word-presentations, 1873  
 “On Arrogance” (Bion), 51, 121  
 “On beginning the treatment” (Freud), 422, 541, 616, 664, 835, 1068, 1384  
*On Countertransference* (Heimann), 1440  
 “On Dreams” (Freud), **1190**, 1302  
 “On Forced Phantasies” (Ferenczi), 95–96  
*On Hate in Love Relationships: The Narcissism of Minor Differences Revisited* (Gabbard), 1109  
 On Jung, Carl Gustav and, 660, 1467  
 “On Narcissism: An Introduction” (Freud), **1190–1192**  
 on alteration of the ego, 468  
 on autoeroticism, 141  
 on castration complex, 252  
 collective psychology and, 311  
 on conflict, 326  
 on dementia, 389  
 on drives, 445  
 on ego, 463  
 on ego ideal, 479  
 on Eros, 513  
 on erotogenicity, 519–520  
 on female sexuality, 573  
 First World War and, 585  
 Freud-Jung split and, 639  
 on functional phenomenon, 654–655  
 on heroic self, 739  
 on homosexuality, 757  
 on hypochondria, 770  
 on ideal ego, 481  
 on infant development, 814  
*Jahrbuch der Psychoanalyse* and, 884  
 on libido, 484–485, 968  
 on masculinity/femininity, 1400  
 on monism, 1071  
 “Mourning and Melancholia” and, 1082  
 on narcissism, 1104–1105, 1106  
 on narcissistic withdrawal, 1116

Volume 1, pp. 1–662; Volume 2, pp. 663–1344; Volume 3, pp. 1345–1892

- on object-choice, 1175  
 on omnipotence of thoughts, 1189  
 on organ pleasure, 1205  
 on paraphrenia, 1234  
 on penis envy, 1246  
 on primary narcissism, 1110  
 on psychoses, 1404  
 on racism/anti-Semitism, 1438  
 on secondary narcissism, 1110–1111  
 on self-consciousness, 1570  
 on self-esteem, 1570  
 on Shakespeare, 1598  
 on Silberer, 1608  
 on superego, 471, 1690  
 on turning around, 1807  
*On Not Being Able to Paint* (Blackett-Milner), 190  
 “On Parapraxes in Korsakov Psychosis” (Hartmann), 727  
 “On Psychic Causality” (Lacan), 929  
 “On Psychoanalysis” (Freud), 130  
 “On Psychoanalysis. Sexuality in the Neuroses” (Aragão de Souza Pinto), 213  
 “On Psychotherapy” (Freud), 1411  
 “On Repression” (Balint-Szekely-Kovács), 149  
 “On Repression” (Freud), 1281  
 “On the Grounds for Detaching a Particular Syndrome from Neurasthenia under the Description ‘Anxiety Neurosis’”. *See* “Detaching a Syndrome of Anxiety Neurosis from Neurasthenia”  
 “On the History of the Psychoanalytic Movement” (Freud), **1192–1193**  
 on “Anna O.” case, 88  
 on Chilean psychoanalysis, 284  
 on complexes, 319  
 Delgado and, 385  
 Freud-Jung split and, 639, 1191, 1192–1193  
 on Hesnard and Régis, 741  
 on hypnoid states, 768  
*Jahrbuch der Psychoanalyse* and, 884  
 on Marcinowski, 1011  
 on Morichau-Beauchant, 1075  
 on *Psychanalyse des névroses et des psychoses, La*, 1361  
 on repression, 1482, 1485  
 on *Revista de psiquiatria y disciplinas conexas*, 1497  
 on *Studies on Hysteria*, 1671–1672  
 on Swedish psychoanalysis, 1697  
 “On the Incapacity to Bear Depression” (Zetzel-Rosenberg), 1888  
 “On the Mechanism of Sleep and Dreaming” (Alvarez de Toledo), 55  
 “On the Nature and Function of Phantasy” (Isaacs-Sutherland), 552, 801  
*On the Nightmare* (Jones), 893, 1150  
 “On the Origin of the ‘Influencing Machine’ in Schizophrenia” (Tausk), 971, 1106, **1193–1194**, 1727  
 “On the Psychic Mechanisms of Hysterical Phenomena” (Freud and Breuer), 225, 384, 768, 1689–1690, 1826  
*On the Psychoanalysis of War Neuroses* (Simmel), 1612  
 “On the Psychology and Pathology of So-Called Occult Phenomena” (Jung), 356  
 “On the Psychotherapies, for the Practicing Physician” (Balint), 149  
 “On the Sexual Theories of Children” (Freud), **1194–1195**  
 on castration complex, 251  
 on disavowal, 415  
 on fantasy, 551  
 on female sexuality, 574  
 on infantile sexual curiosity, 1590  
 on knowledge instinct, 917  
 on penis envy, 1245–1246  
 on primal scene, 1310  
 on secrets, 1560  
 on thought, 1746  
 “On the Universal Tendency to Debasement in the Sphere of Love” (Freud), 252, 342, 346, 995, 1319, 1597–1598, 1616  
 “On Transformations of Instinct as Exemplified in Anal Erotism” (Freud), 252, 514–515, 682, 1069  
 “On Transience” (Freud), 1080, 1081, **1195–1196**  
 Onanism. *See* Masturbation  
*One Dimensional Man* (Marcuse), 1013  
*One Flew Over the Cuckoo’s Nest* (film), 292  
 Ontogenesis, 297, **1196–1198**  
 archaic and, 112  
 maternal reverie and, 1030–1031  
 phylogenesis and, 1196, 1197, 1277, 1278  
 Operational thinking, **1198–1199**, 1409  
 Operative thinking. *See* Operational thinking  
*Opere* (writings of Sigmund Freud), **1199**  
 Ophelia, 27  
 Ophuijsen, Johan H. W. Van. *See* Van Ophuijsen, Johan H. W.  
 OPLF (Organisation psychanalytique de langue française), 129  
 Oppenheimer, Agnès, 447, 830, 1785  
 Oppenheimer, Hermann, 1803  
 Oppenheimer, Robert, 1529  
 Opposites. *See* Pairs of opposites  
 Optical schema, **1200–1202**, 1840–1841  
 Oraison, Abby Marc, 156  
 Oral dependence, 392  
 Oral eroticism, **515–516**  
 Oral fixation, 41, 91, 394  
 Oral-sadistic stage, **1203–1204**  
 Abraham, Karl on, 6, 1038, 1082, 1114, 1203  
 activity/passivity and, 17  
 anal eroticism and, 515  
 breastfeeding and, 220, 221  
 cruelty and, 355  
 identification and, 787  
 melancholia and, 1038, 1082, 1203  
 narcissistic neuroses and, 1114  
 sadism and, 1525  
 “vagina dentata” fantasy and, 1831  
 weaning and, 1851–1852  
 Oral stage, **1204–1205**  
 Abraham, Karl on, 6, 57, 516, 1203, 1204–1205  
 activity/passivity and, 17  
 ambivalence and, 57  
 erotogenic masochism and, 517, 518  
 oral eroticism and, 516  
 wish for a baby and, 1864  
*See also* Cannibalistic stage; Oral-sadistic stage  
 Orality, **1202–1203**  
 ambivalence and, 57, 1202  
 Bergler on, 153  
 bulimia and, 233  
 conflict and, 326  
 demand and, 388  
 pregnancy fantasy and, 1302  
*See also* Oral-sadistic stage; Oral stage  
 Orchard, William, 132  
*Ordalia*, 1686  
*Ordre psychosomatique, L’* (Marty), 421, 1016  
 Orestes, 27  
 Organ pleasure, **1205–1206**  
 Organic dysfunctions, 22  
 Organic psychoses, **1206**  
 Organic repression, **1206–1208**  
 Organicism, 37, 539  
 Organisation psychanalytique de langue française (OPLF), 129  
 Organization, **1208–1209**  
 castration complex and, 254  
 ethology and, 528

## INDEX

Volume 1, pp. 1–662; Volume 2, pp. 663–1344; Volume 3, pp. 1345–1892

- genital stage and, 672  
 psychosexual development and, 1407  
 Organization of Independent Medically Qualified Analysts, 1657  
 Organizer principle, 1664  
 Organodynamic current, 1392  
 Organogenesis. *See* Psychogenesis/organogenesis  
 Orgasm, 26, **1209–1210**, 1594  
 Orgone energy, **1210–1211**  
*Orientations des idées médicales* (Orientations of medical ideas) (Allendy), 46  
*Origin of Species, The* (Darwin), 366  
 Original narcissism. *See* Primary narcissism  
*Origins of Love and Hate, The* (Suttie), 1457–1458  
*Origins of Psycho-Analysis, The* (Freud), 802  
 “Origins of the Fetishistic Plaything of Sexual Perversions, The” (Meltzer), 419  
*Ornicar?*, 458, 611, **1211**, 1552  
 Orphism, 1097  
 Orr, Douglass W., 1529  
 Ortega y Gasset, José, 175, 1637  
 Orwell, George, 44, 111  
 O’Shaughnessy, Edna, 132  
 Osipov, Nikolai, 1518  
 Osofsky, Joy, 888  
 Ossipov, Nikolai Legrafovitch, 360, 432, **1211–1212**, 1411  
 Österreichische Arbeitskreise für Psychanalyse, 134  
 Ostow, Mortimer, 877  
 Ostwald, Wilhelm, 1070  
 “Othello” (Green), 1669  
 Other, the, 930, **1212–1214**  
 alienation and, 43–44  
 autohistorization and, 142  
 Big Other, 53, 1202  
 Certeau on, 266  
 demand and, 388  
 ego and, 465  
 erotogenicity and, 521  
 ethics and, 526  
 fantasy and, 554  
 foreclosure and, 595  
 Graph of Desire and, 693–695, 895  
 hatred and, 729  
 hysteria and, 773  
 ideational representation, 785  
 imaginary and, 799  
 L and R schemas and, 927  
 listening and, 984  
 mirror stage and, 1058–1059  
 optical schema and, 1200, 1201–1202  
 phallus and, 1264–1265  
 repetition compulsion and, 1475  
 signifiers and, 1605  
 splitting of the subject and, 1649  
 subject and, 1673  
 subject of the drive and, 1674  
 subject of the unconscious and, 1675  
 subject’s castration and, 1676  
 subject’s desire and, 1678  
 unary trait and, 1814  
*Other, The* (Bahr), 1215  
 “Other Side of Psychoanalysis, The” (Lacan), 601–602, 931  
 Otherness, **1214–1215**, 1271, 1774  
 Other’s object, 1186  
 Ottalagano, Cesar Augusto, 1832  
 Otto, Rudolf, 1164  
 Ouaknin, Marc-alain, 241  
 “Our Adult World and Its Roots in Infancy” (Klein), 1567  
*Our Inner Conflicts* (Horney), 759  
 Oury, Jean, 1765, 1766  
 “Outline of Psychoanalysis, An” (Freud), **1215–1216**  
 on acting out, 11  
 on adaptation, 22  
 on agency, 33  
 alcoholism and, 42  
 on attention, 127  
 on binding/unbinding, 180  
 on breastfeeding, 221  
 on compulsion, 322, 323  
 on dreams of convenience, 344  
 on ego, 466  
 on genital stage, 672  
 on internal/external reality, 848  
 on latent/manifest dream elements, 947, 1007  
 on libido, 969, 970  
 on life instinct, 975  
 on lifting of repression, 1486  
 on myth of origins, 1092  
 on perception-consciousness system, 1248  
 on pregenital organization, 1302  
 on psychic apparatus, 1351  
 on psychic causality, 1354  
 on scientific nature of psychoanalysis, 1550  
 on seduction theory, 1564  
 on splitting of the ego, 1647–1648  
 on sucking, 1682  
 on therapeutic alliance, 1740  
 on word-presentations, 1873  
 on working-through, 1880  
 Over-interpretation, **1217**  
 Overdetermination, 325, **1216–1217**  
 Ovesey, Lionel, 907  
 Oxford Group, 999  
 Oxford ruling, 1550
- ## P
- Pabst, Georg Wilhelm, 674, 1365, 1523, 1562  
 Pacella, Bernard L., 1600  
 Pache, Francis, 1640  
 Pacheco de Almeida Prado, Mario, 215  
 Pagès, Max, 1632  
 Pailthorpe, Grace, 684  
 Pain, **1219–1220**, **1280–1281**  
 pleasure principle and, 1290  
 “Project for a Scientific Psychology, A” on, 1219, 1280, 1333  
 self-mutilation and, 1573  
 skin and, 1613  
 Pairing, as basic assumption, 151, 709, 711  
 Pairs of opposites, 3–4, 1020, **1220–1221**, 1495  
*See also* Dualism  
*See also specific pairs*  
 Paiva, Miller de, 216  
 Pakesch, Eric, 135  
 Pakesch, Peter, 136  
 Palacio, Paco, 1701  
 Palacio Espasa, Francisco, 1039  
 Palmade, Guy, 1632  
 Palmstierna, Vera, 1698  
 Palo Alto group, 1720–1721  
 Palos, Elma, 209, 747  
 Pankejeff, Serguei, **1221–1222**  
*See also* “Wolf Man” case  
 Pankow, Gisela, **1222–1223**, 1348, 1404, 1538  
 Pansexualism, 1593  
*Pansexualismo na doutrina de Freud, O* (Franco da Rocha), 614  
 Pantophobia, 1273–1274  
 Pappadis, Thomas, 279  
 Pappenheim, Bertha, 338, **1223–1225**  
*See also* “Anna O.” case  
 Paracelsus, 46  
 Parade of signifiers, **1225**  
 Paradigmatic axis, 1606  
 Paradox, 433–434, 1127, **1225–1226**, 1720  
 “Paradoxes des schizophrènes” (Racamier), 1226

Volume 1, pp. 1–662; Volume 2, pp. 663–1344; Volume 3, pp. 1345–1892

- Paradoxical (REM) sleep, 1614
- Paranoia, **1226–1231**  
 creativity and, 352  
 Enriquez-Joly on, 506  
 homosexuality and, 757, 1227, 1229–1230, 1231  
 hypochondria and, 770–771  
 identification and, 790  
 Kraepelin on, 36–37  
 Lacan on, 37–38  
 megalomania and, 1036  
 melancholia and, 1037  
 passage to the act and, 18–19  
 psychoses and, 1403–1404  
 Schreber case and, 1227, 1229, 1230, 1545  
 social feeling and, 1618  
 splitting of the ego and, 1227, 1647
- Paranoid position, 396, **1231–1232**, 1326  
*See also* Paranoid-schizoid position
- Paranoid psychosis, **1232**
- Paranoid-schizoid position, **1233–1234**  
 adhesive identification and, 24  
 anal eroticism and, 515  
 anxiety and, 100–101  
 archaic and, 112, 113  
 bizarre object and, 188  
 Bleger on, 194  
 defense mechanisms and, 375  
 disintegration anxieties and, 418  
 emotions and, 501  
 Fairbairn on, 697  
 helplessness and, 734  
 infant observation and, 816  
 infantile psychosis and, 826  
 introjection and, 870  
 paradox and, 1226  
 paranoid position and, 1231  
 paranoid psychosis and, 1232  
 projective identification and, 1233, 1338  
 selected facts and, 1566  
 splitting and, 1646  
 splitting of the object and, 1642  
 stammering and, 1653  
 thought-thinking apparatus and, 1750
- Paranormal phenomena, 112, 640, 1145, 1180–1181, 1586, 1816, 1854  
*See also* Telepathy; Uncanny, the
- Paraphasia, 1615
- Paraphrenia, **1234–1235**  
 delusions and, 386  
 hypochondria and, 770  
 paranoid psychosis and, 1232
- psychoses and, 1403  
 secondary narcissism and, 1110
- Parapraxes, **1235–1236**  
 conflict and, 325  
 constructions and, 338  
 forgetting as, 596, 597  
 language and, 942  
 symptoms and, 1715  
*See also* Slips of the tongue
- Parasitic relations, 1464
- Parat, Catherine, 327, 671, 1174–1175, 1789
- Parcheminey, Georges, **1236–1237**  
 Bouvet and, 210, 1236  
 Clark-Williams trial and, 304  
 Congrès des psychanalystes de langue française des pays romans and, 329, 330  
 Delay and, 383, 1236  
 French psychoanalysis and, 608  
 Loewenstein and, 989, 1236  
 Schlumberger and, 1541  
 Société psychanalytique de Paris and, 1236, 1623
- Parent-infant psychotherapy, 1382, 1784
- Parenthood, 160, **1237–1238**, 1304–1305  
*Parenthood and Social Reproduction* (Goody), 1237  
*Parenthood as a Developmental Phase* (Benedek), 160
- Parin, Paul, 1060, 1703
- Paris Psychoanalytic Society. *See* Société psychanalytique de Paris
- Parkin, Alan, 244
- Parmenides, 313, 1070
- Paroxysmality theory, 1722
- Parres, Ramón, 1051
- Parricide, 431–432, 526, **1238–1239**  
 castration complex and, 251  
 family and, 547  
 fantasy and, 552  
 identification and, 789  
*Moses and Monotheism* on, 1077, 1078  
 myth of origins and, 1091–1092  
 phobias and, 1274  
*See also* Myth of origins
- Parsons, Talcott, 31, 1087, 1825
- Part, Arturo, 284
- Part-objects, 1168  
 castration complex and, 252  
 internal objects and, 850  
 melancholia and, 1038, 1039  
 paranoia and, 1228  
 self-mutilation and, 1573  
 sexuality and, 1594
- splitting of the object and, 1649  
 transference and, 1783  
*See also* Object loss
- Partial drives, **1239–1241**, 1257–1258, 1332, 1506  
 “Participation mystique”, 1337–1338, 1779
- Pasche, Francis Léopold Philippe, **1241–1242**  
 on antinarcissism, 97, 1114  
 Congrès des psychanalystes de langue française des pays romans and, 330  
 on counter-Oedipus, 348  
 on excitation, 534  
 French psychoanalysis and, 609  
 Granoff and, 692  
*Inconscient, L’* and, 807  
 Leuba and, 963, 1242  
 Marty and, 1016  
 on moral masochism, 1072  
 on narcissism, 1111, 1114  
 on paradox, 1226  
 Racamier and, 1435  
 on repetition compulsion, 534  
 Société psychanalytique de Paris and, 1626, 1628
- Pass, the, 458, **1242–1243**, 1251  
 École de psychanalyse Sigmund Freud and, 456  
 École Lacanienne de psychanalyse and, 1084  
 Leclaire on, 957  
 Quatrième Groupe and, 1430  
 training analysis and, 1770
- Passage à l’acte*. *See* Passage to the act
- Passage à l’acte* (film), 292, 294
- Passage to the act, 10, **18–19**, 1390
- Passeron, René, 1696
- Passion, 386, **1243–1244**
- Passivity. *See* Activity/passivity
- Pathologie d’l’imagination et de l’émotivité* (Dupré), 1098
- “Paths of Psychoanalytic therapy, The” (Freud), 586
- Patio*, 178
- “Paul” (Schlumberger), 1542
- Paul, Jean, 673, 891, 1857
- Paula, Aloysio de, 214
- Pauli, Wolfgang, 1720
- Pauluan, Liliana, 285
- Paumelle, Philippe  
 Association de santé mentale and, 610, 911, 955  
 Diatkine and, 410

## INDEX

Volume 1, pp. 1–662; Volume 2, pp. 663–1344; Volume 3, pp. 1345–1892

- Kestenberg-Hassin and, 911  
 Racamier and, 1435  
 Pavlov, Ivan, 286, 414, 678  
 Payment for treatment, 1068–1069, 1732  
 Payne, Sylvia May, **1245**  
 Blackett-Milner and, 190  
 British Psycho-Analytical Society and, 228, 343, 344, 1245  
 Controversial Discussions and, 343, 344, 697, 1245  
 on femininity, 577  
 Glover, James and, 685, 1245  
 Rycroft and, 1520  
 Strachey-Sargent and, 1664  
 Tavistock Clinic and, 1728  
 Paz, Octavio, 241  
 Pazmany-Peter University Medical School, 1721  
 Pcpt.-Cs. system. *See* Perception-consciousness (Pcpt.-Cs.) system  
 Peale, Norman Vincent, 193  
 Pedersen, Stefi, 1698  
 Pedophilia, 1595  
*Peeping Tom* (film), 294  
 Peña, Saul, 566, 1253–1254  
 Penis, 1676  
 breastfeeding and, 220  
 disavowal and, 415–416  
 as good/bad object, 219, 418  
*See also* Castration anxiety; Castration complex; Penis envy; Phallus  
 Penis envy, 570, 573, **1245–1246**, 1635  
 aphanisis and, 105  
 biological bedrock and, 182, 254  
 castration complex and, 252, 253, 254, 1246  
 death instinct and, 508  
 disavowal and, 415  
 feminist views of psychoanalysis and, 576, 578  
 fetishism and, 582  
 object-choice and, 1174  
 Oedipus complex and, 1185, 1246  
 Perrier on, 574  
 phallic stage and, 1263  
 pregnancy fantasy and, 1302  
 primary narcissism and, 1110  
 rejection of femininity and, 575  
 sexual difference recognition and, 1594  
 termination of treatment and, 1738  
 wish for a baby and, 571, 1864  
*Pensée opératoire, La* (Marty and M'Uzan), 1016  
*Penser, Le: Du Moi-peau au Moi-pensant* (Anzieu), 1341  
*Penthesilea* (Kleist), 1656  
 Peraldi, François, 245, 864, **1247–1248**  
 Perception  
 consciousness and, 333, 334  
 dismantling and, 419–420  
 estrangement and, 524  
 mnemonic traces and, 1062, 1063  
 mystic writing pad and, 1159–1160  
 perception-consciousness system and, 1248–1249  
 representation and, 781  
 surrealism and, 1696  
 Perception-consciousness (Pcpt.-Cs.) system, **1248–1249**  
 Perceptual identity, 536, **1249–1250**  
 Pereda, Alberto, 566, 1829  
 Pereira Anavitarte, Juan, 1829  
 Perelberg, Rosine, 577  
 Perestrello, Danilo, **1250**  
 Brazilian psychoanalysis and, 214, 215, 216, 1250  
 Cárcamo and, 248  
 Perestrello, Marialzira, 214, 215, 216–217, 248  
 Péret, Benjamin, 1695–1696  
 Pérez Pastorini, Valentin, 1828  
 Pérez Sánchez, Manuel, 933, 1638  
 Perfectionism, 1141  
 Perls, Fritz, 1200  
 Pernambuco, Ulisses, 214  
 Perotti, Nicola, 330  
 Perret, William, 449  
 Perrier, François, **1250–1251**  
 on alcoholism, 42  
 Aulagnier-Spairani and, 129  
*Bloc, Le—Notes de la psychanalyse* and, 195  
 Bouvet and, 211, 1251  
 on claustrophobia, 306  
 Colloque sur l' inconscient and, 314, 610  
*Confrontation* and, 327  
 École freudienne de Paris and, 457, 458, 1251  
 on female sexuality, 574  
 French psychoanalysis and, 613  
 French psychoanalytic establishment split (1953) and, 692, 1251  
 French psychoanalytic establishment split (1964) and, 611, 957, 1251, 1645  
*Inconscient, L'* and, 807  
 on pass, 1242, 1243, 1251  
 on perversion, 1259  
*Psychanalyse, La* and, 1348  
 on psychogenesis, 610  
 Quatrième Groupe and, 611, 807, 1251, 1429–1430, 1645  
 Société française de psychanalyse and, 1619  
 Perron, Roger  
 on developmental processes, 1330  
 on genital love, 671  
 on libidinal stages, 967  
 on phylogenesis, 1278  
 psychological tests and, 1395  
 on psychology and psychoanalysis, 1398  
 on psychosexual development, 1406, 1407  
 on representation, 782  
 Société psychanalytique de Paris and, 1629  
 on working over, 1878  
 Perron-Borelli, Michèle  
 on fantasy, 552–553  
 on genital love, 671  
 on libidinal stages, 967  
 on psychosexual development, 1406, 1407  
 on representation, 782  
 Société psychanalytique de Paris and, 1627, 1630, 1631  
 on specific actions, 1639  
 on stages, 1652  
 on working over, 1878  
 Perrotti, Nicola, **1251–1252**  
 Corrao and, 347  
 Italian psychoanalysis and, 878, 879, 881, 1251, 1854  
*Psyché* and, 1350  
*Rivista di psicoanalisi* and, 1508  
 Servadio and, 1586  
 Tomasi and, 1758  
 Weiss and, 1251, 1854  
 Perse, J., 506  
 Persecution, **1252–1253**  
 anxiety and, 100, 826, 1039  
 guilt and, 718  
 phobias and, 1275  
*See also* Paranoia  
 Person, Ethel, 576  
 Persona, 1596  
*Persona* (film), 294  
 Personality, 32, 37, 38, 334, 350  
*Personality in Nature, Culture, and Society* (Murray and Kluckhohn), 1087  
 “Personification in the play of children” (Klein), 1648  
*Perspectives de la psychanalyse* (Ferenczi and Rank), 1729  
 Pertejo, J., 1637

Volume 1, pp. 1–662; Volume 2, pp. 663–1344; Volume 3, pp. 1345–1892

- Peruvian psychoanalysis, 384–385, **1253–1255**, 1496–1497, 1831–1832
- Peruvian Psychoanalytic Society, 1254
- Pervasive developmental disorders, 828
- Perversion, **1255–1259**
- alienation and, 44
  - amphimixia and, 66
  - Bak on, 147
  - component instincts and, 1752
  - dismantling and, 419
  - Fornari on, 598
  - gaze and, 990
  - mastery and, 1024
  - neuroses and, 326
  - psychosis/neurosis distinction and, 1415–1416
  - splitting and, 1646
  - Stoller on, 1660
  - voyeurism, 17, 1021, 1675, 1807, 1808, 1842–1843
- See also* Exhibitionism; Fetishism; Masochism; Polymorphous perversity; Sadism
- Perversion* (Stoller), 1660
- Peterfreund, Emanuel, 1517
- Petersen, P. C., 390
- Peterson, Frederick, 227
- Petitot, Jean, 327
- Peto, Andrew, 131, 393
- Petot, Jean-Michel, 112, 653, 1326
- Pfeifer, Zsigmond, 765, 766
- Pfister, Oskar Robert, **1259–1261**
- altruism and, 53
  - Danish psychoanalysis and, 390
  - Delgado and, 385
  - Ellenberger and, 497, 1260
  - Future of an Illusion, The* and, 660, 1260
  - Hirschfeld, Elfriede and, 747
  - Institut Jean-Jacques Rousseau and, 302
  - lay analysis and, 1644
  - Oberholzer and, 1167, 1260
  - photograph of, III:pl.2
  - Piaget and, 1260, 1282
  - on religion, 1467
  - Schneider and, 1260, 1544
  - on sublimation, 1679
  - Swedish psychoanalysis and, 1698
  - Swiss psychoanalysis and, 1260, 1513, 1549, 1550, 1700, 1702, 1703
  - Zeitschrift für psychoanalytische Pädagogik* and, 1886
  - Zulliger and, 1260, 1888
- Phallic mother, 573, **1261–1262**, 1263–1264
- “Phallic Phase and its Disturbances in Young Girls, The” (Bibring-Lehner), 177
- Phallic stage, **1262–1263**
- castration anxiety and, 101
  - conflict and, 326
  - disavowal and, 415
  - erotogenic masochism and, 518
  - female sexuality and, 570, 1263
  - genital stage and, 672
  - “Little Hans” case and, 75
  - object-choice and, 1174
  - pregenital organization and, 1302
  - urethral eroticism and, 517
- Phallic woman, **1263–1264**
- See also* Phallic mother
- Phallus, **1264–1265**
- castration complex and, 252
  - female sexuality and, 365, 570–571, 578, 1185–1186, 1265
  - feminist views of psychoanalysis and, 578
  - gaze and, 990
  - jouissance and, 895
  - masculinity/femininity and, 1019–1020
  - modesty and, 1067
  - Name-of-the-Father and, 1104
  - perversion and, 1258
  - sexual difference recognition and, 1588, 1589
  - sexuation and, 1595
  - subject’s castration and, 1676–1677
  - subject’s desire and, 1678
  - symbolic and, 1264, 1710
  - symptoms and, 1718
- See also* Penis
- Phantasie*. *See* Fantasy; Reverie
- Phantom, **1265–1266**, 1560
- Phantom of Liberty, The* (Buñuel), 1067
- Phenomenology, **1266–1268**
- amnesia and, 64, 65
  - Fédida and, 569
  - intersubjective/intrasubjective dichotomy and, 867
  - lack of differentiation and, 933
  - lifting of amnesia and, 976, 977
  - Merleau-Ponty on, 1047, 1266
  - Minkowski on, 1057, 1267
  - Pankow and, 1222
- Phenomenology of Perception* (Merleau-Ponty), 1047
- Phenothiazine, 1540
- Philadelphia Association, 699
- Philippe case, 110
- Philippines. *See* Filipino psychoanalysis
- Philippson Bible, 624, **1269**
- Philips, Frank, 214, 217, 919
- Philipson, T., 390
- Phillips, A. R., 131
- Philobatism, 149, 152
- Philosophy, **1269–1272**
- Favez-Boutonier and, 559
  - French psychoanalysis and, 613
  - monism, 1070
  - thought identity and, 1749
  - Weltanschauung* and, 1855
- See also* Phenomenology
- See also specific philosophers*
- Phobia, 1678
- Phobia of impulsive acts, **1272–1273**
- Phobias
- active technique and, 15
  - in children, **1273–1276**
  - claustrophobia, 306
  - counterphobic phenomena and, 349
  - delusions and, 385
  - desexualization and, 398
  - obsessions and, 1178
  - phobia of impulsive acts, 1272–1273
  - phobic neurosis and, 19, 306, 1276
- Phobic neurosis, 19, 306, 1276
- Phobic signifier, 1275, 1276
- Phylogenesis, **1277–1279**
- archaic and, 111–112, 113, 358
  - cultural transmission and, 357–358
  - Darwinism and, 366–367, 1277
  - developmental processes and, 1330
  - externalization-internalization and, 537
  - fantasy and, 551
  - fatherhood and, 558
  - Ferenczi on, 1278, 1738–1739
  - history and, 750
  - internal/external reality and, 848
  - latency period and, 946
  - mnemic traces and, 1064
  - mythology and, 1095–1096
  - Oedipus complex and, 1184
  - ontogenesis and, 1196, 1197, 1277, 1278
  - organic repression and, 1206, 1208
  - primal and, 1312
  - primal fantasies and, 1308
  - primal repression and, 1309
  - primitive and, 1319
- See also* Myth of origins
- Phylogenetic Fantasy, A: Overview of the Transference Neuroses* (Freud), 1278, **1279–1280**

## INDEX

Volume 1, pp. 1–662; Volume 2, pp. 663–1344; Volume 3, pp. 1345–1892

- on anxiety neurosis, 1137  
 on Darwinism, 366  
 on developmental processes, 1330  
 on history, 750  
 on myth of origins, 1091–1092, 1093, 1184  
 Physical pain. *See* Pain  
 Piaget, Jean, **1281–1282**  
   Caruso and, 248  
   cognitivism and, 308  
   Congrès des psychanalystes de langue française des pays romans and, 330  
   on ego, 477  
   on epistemology, 1369  
   Guex and, 714  
   Isaacs-Sutherland and, 873  
   Mead and, 1035  
   Odier and, 1182  
   Pfister and, 1260, 1282  
   Rambert and, 1442  
   Sechehaye and, 1556  
   on stages, 1651  
   structuralism and, 1669  
   Swiss psychoanalysis and, 1620  
   on unconscious, 1307  
   on unconscious fantasies, 1818  
 Pichon, Édouard Jean Baptiste, **1282–1284**  
   Allendy and, 46  
   Claude and, 305  
   Congrès des psychanalystes de langue française des pays romans and, 329, 608  
   Dalbiez and, 363, 1283  
   Delay and, 383  
   Dolto-Marette and, 427, 1346  
   Dugautiez and, 450  
   Ey and, 539  
   French psychoanalysis and, 608  
   on group psychotherapies, 713  
   on intergenerational phenomena, 846  
   Janet and, 886, 1283  
   Laforgue and, 933, 1283, 1284  
   Lieberman and, 964  
   on linguistics, 982  
   Martins, Cyro and, 1015  
   Maurras and, 1283, 1624  
   Minkowska-Brokman and, 1056  
   Parcheminey and, 1236  
   *Revue française de psychanalyse* and, 200, 1283, 1497, 1498  
   on scotomization, 1554  
   Société psychanalytique de Paris and, 200, 1623, 1624  
   Sokolnicka-Kutner and, 1283, 1292, 1634  
   Pichon-Rivière, Enriqué, **1284–1285**  
   Aberastury and, 4  
   Alvarez de Toledo and, 55  
   Argentinian psychoanalysis and, 117, 118, 193, 1284–1285  
   Baranger and, 150  
   Swedish psychoanalysis and, 1700  
 Pichot, Pierre, 506  
 Picht, Carl, 154  
 Pick, Arnold, 1538  
 Pictogram, **1285–1287**  
   breastfeeding and, 221  
   ideational representation and, 785  
   *infans* stage and, 813  
   primal and, 1312–1313  
   visual and, 1841  
*Picture of Dorian Gray, The* (Wilde), 429  
 Pierce, Charles Sanders, 1708  
 Pieringer, W., 135  
 Piéron, Henri, 89, 90  
 Piers, Gerhart, 278  
 Pinchon, Édouard, 1528  
 PINE (Psychoanalytic Institute of New England), 208  
 Pine, Fred, 1382  
 Pinel, Philippe, 389, 1178, 1272, 1528  
 Pines, Dinora, 577  
 Pines, Malcolm, 391  
 Piñol-Douriez, Monique, 815  
 Pinsky, Leon, 291  
 Piralissn, Hélène, 1439  
 Pitres, Albert  
   on claustrophobia, 306  
   Hesnard and, 741  
   on phobias, 1272, 1273  
   Régis and, 1458, 1459  
 Pitt, B., 1297  
 Pius XII (Pope), 879  
 Pivaz, Élisabeth, 933  
 Placheta, Krista, 133  
*Plaisir de pensée, Le* (Mijolla-Mellor), 1749  
 Planck, Max, 401  
*Plans and the Structure of Behavior* (Miller, Galanter, and Pribram), 308  
 Plata Mújica, Carlos, 315, 566  
 Plato  
   collective unconscious and, 313  
   on Eros, 512, 513  
   ideology and, 795  
   on illusion, 796  
   on linguistics, 982  
   memoirs of the future and, 1039  
   on memory, 1042, 1043  
   mythology and, 1097  
   on Other, 1213  
   on otherness, 1214, 1271  
   on passion, 1243  
   pleasure in thinking and, 1289  
   on psyche, 1348–1349  
 Platonic types, 1588  
 Play. *See* Children's play  
*Playing and Reality* (Winnicott), 1793, 1794, 1796  
 Plé, Father Albert, 156  
 Pleasure  
   amphimixia and, 66–67  
   erotogenic zones and, 518  
   jouissance and, 894, 1475  
   sexualization and, 1595  
   skin and, 1613  
   splitting of the object and, 1642  
   *See also* Jouissance; Pleasure principle  
 Pleasure ego/reality ego, 729, 1027, **1288–1289**, 1423  
 Pleasure in thinking, **1289–1290**, 1456  
 Pleasure principle, 16, **1290–1291**, 1325–1326  
   act/action and, 9  
   alcoholism and, 42  
   Bion on, 952  
   children's play and, 282  
   conflict and, 326  
   conscious processes and, 332, 333  
   constancy principle and, 1323  
   death instinct and, 371  
   dependence and, 391–392  
   discharge and, 417  
   erotogenic masochism and, 517  
   excitation and, 534, 1290, 1753  
   fantasy and, 551  
   Fechner on, 565  
   Freud on, 174, 1290–1291, 1325–1326  
   hallucinatory wish-fulfillment and, 1866  
   historical reality and, 748  
   id and, 778  
   Nirvana principle and, 1151, 1291  
   primary object and, 1317  
   primary/secondary processes and, 1290, 1318  
   “Project for a Scientific Psychology, A” on, 1325, 1332–1333  
   psychic reality and, 1357  
   quantitative/qualitative dimensions and, 1428  
   reality principle and, 1291, 1450  
   repetition compulsion and, 1474

Volume 1, pp. 1–662; Volume 2, pp. 663–1344; Volume 3, pp. 1345–1892

- Schur on, 1549  
 scientific nature of psychoanalysis and, 1551  
 self-preservation and, 1575  
 suffering and, 1684  
 transgression and, 1792–1793  
 turning around and, 1807  
 Pleasure/unpleasure principle. *See* Pleasure principle  
 Ploëtz, Alfred, 1437  
 Plosa, Isabel, 1829  
 Plotinus, 1352  
 PM. *See* Psychic masochism  
 Poe, Edgar Allan, 200, 927, 974, 1669  
 Poetry. *See* Literature  
 Poincaré, Henri  
 catastrophe theory and, 256  
 Le Bon and, 953  
 on selected facts, 1123–1124, 1566, 1750  
 on thought-thinking apparatus, 1750  
 Poincaré, Raymond, 953  
*Point de capiton*, 1607  
 Poisson, Jacques. *See* Allendy-Nel-Dumouchel, Yvonne  
 Poland. *See* Polish psychoanalysis  
 Polarities. *See* Activity/passivity  
 Polish psychoanalysis, 888, 1291, **1291–1293**  
 Polish Society for the Development of Psychoanalysis, 1292  
 Politics, **1293–1294**  
 belief and, 159  
 Bullitt and, 234–235  
 International Psychoanalytical Association and, 858  
 Rolland and, 1511  
 Silberstein and, 1609–1610  
*Weltanschauung* and, 1855  
 “Politics of Experience, The” (Laing and Esterson), 699  
 Politzer, Georges, **1294**  
 French psychoanalysis and, 609  
 philosophy and, 1271  
 on psychic apparatus, 1352  
 on scientific nature of psychoanalysis, 704  
 Pollaiuolo circle, 347  
 Pollitzer, Georges, 1047  
 Pollock, George, 278, 279  
 Polymorphous perversity, 1593, 1753  
 amnesia and, 64  
 drives and, 445  
 genital stage and, 672  
 libidinal development and, 965  
 metapsychology and, 1257  
 ontogenesis and, 1197  
 partial drives and, 1240  
 sublimation and, 1679  
 “Polysexuality” (Peraldi), 1247  
 Pontalis, Jean-Bertrand  
 on cinema, 294–295  
*Confrontation* and, 327  
*Connaissance de l'inconscient* and, 611  
 on contact, 338–339  
 on drives, 447  
 French psychoanalysis and, 613  
 French psychoanalytic establishment split (1964) and, 122  
 on Freud, *The Secret Passion*, 645  
 Groddeck and, 706  
 group analysis and, 610, 710, 1371  
 “Homme au magnétophone, L” and, 612  
 Khan and, 913  
 on negative therapeutic reaction, 1126  
*Nouvelle Revue de psychanalyse* and, 124, 611, 913, 1162, 1163  
 on pain, 1219  
 on primal fantasies, 848, 1307, 1308  
 on psychosexual development, 1407  
 Société française de psychanalyse and, 1619  
 Société psychanalytique de Paris and, 1628  
 on suffering, 1684  
 surrealism and, 1696  
*See also Language of Psychoanalysis, The*  
 Pontes, Gernandes, 216  
 Popescu-Sibiu, Ion, 1511  
 Popper, Karl  
 definition of psychoanalysis and, 1364  
 on epistemology, 1370  
 philosophy and, 1271  
 on psychic causality, 1354  
 on psychoanalytic research, 1378  
 Rubinstein and, 1517  
 Popper-Lynkeus, Josef, 356, 1869  
 Porge, Erik, 1084  
 Porot, Antoine, 1098, 1155  
 Portella Nunes, Eustachio, 566  
 Portillo, R. del, 1637  
 Porto-Carrero, Julio Pires, 214, **1295**  
*Portrait métapsychologique de la haine* (Assoun), 729  
 Portugal. *See* Portuguese psychoanalysis  
 Portuguese psychoanalysis, **1295–1297**  
 Portuguese Psychoanalytic Society, 1296–1297  
*Portuguese Review of Psychoanalysis*, 1297  
*Posición y objeto en la obra del Melanie Klein* (Baranger), 150  
 “Position du problème de l'adaptation réciproque entre la société et les psychismes exceptionnels” (Pichon), 1283  
 Positivism, 401, 1378, 1468, 1550–1551  
*Post Card, The*, 328  
 Postnatal depression, **1297–1298**  
 Postpartum depression. *See* Postnatal depression  
 Postpartum psychoses. *See* Puerperal psychoses  
 Posttraumatic stress disorders, 1804, 1849  
 Postural scheme, 1571  
 Potamianou, Anna, 700, 701  
 Potapova, Victoria, 1519  
 Potentiality, 505  
 Potter, Howard, 824  
 Pötzl, Otto, **1298–1299**, 1846  
 Pouillon, Jean, 1162  
 Power, will to, 483  
*See also* Mastery  
*Practice and Theory of Individual Psychology, The* (Adler), 25, 1618  
 Prado de Oliveira, Luiz Eduardo, 1230  
 Prados, Miguel, 242  
 Praeger, Norbert, 1292  
 Pragier, Georges, 1330, 1628  
 Pratt, J. H., 713  
 Pre-oedipal stage  
 acting out and, 11  
 Brunswick on, 232–233  
 female sexuality and, 576, 578  
 paranoia and, 1228  
 passage to the act and, 18  
 Simmel on, 1612  
*Précis de psychiatrie* (Régis), 223, 1459  
 Precocious appearance, 47  
 Preconception, 323, **1299–1300**, 1451–1452  
 Preconscious, the, **1300–1301**  
 Burrow on, 237  
 consciousness and, 333  
 derivatives of the repressed and, 1481  
 forgetting and, 596, 597  
 hypercathexis and, 767  
 insight and, 837  
 perception-consciousness system and, 1248  
 primary/secondary processes and, 1318  
 protective shield and, 1340  
 secondary revision and, 1559  
 somnambulism and, 1636  
 subject's desire and, 1677  
 sudden involuntary ideas and, 1683



## INDEX

Volume 1, pp. 1–662; Volume 2, pp. 663–1344; Volume 3, pp. 1345–1892

- word-presentations and, 1873  
 Preda, Gheorghe, 1511  
 “Predisposition to Anxiety, The” (Greenacre), 702  
 Pregenital organization, 6, **1301–1302**  
 Pregenital stage  
 allergies and, 48  
 anal eroticism and, 514  
 archaic and, 111  
 asthma and, 124  
 fetishism and, 583  
 melancholia and, 1038  
 narcissism and, 1106  
 Oedipus complex and, 1186  
 oral eroticism and, 516  
 perversion and, 1255  
 phallic mother and, 1262  
 Pregnancy fantasy, **1302–1303**  
 Prego Silva, Luis E., 1829  
 Prehistory, 111, **1303–1304**  
 “Preliminary Communication” (Freud and Breuer), 1470, 1483, 1670  
*See also Studies on Hysteria*  
 Prematurity, **1304–1305**  
 Premonitory dreams, **1305**  
 Prepsychosis, 191, **1305–1307**  
 Prereflective unconscious, **1307**  
 Pressure, 323, 446  
 Prevalent ideas, 1178  
 Prévost, Claude, 560  
 Primal, the, 113, 1286, 1308, **1311–1313**  
 Primal cavity, 1682  
 Primal fantasies, 552, **1307–1308**  
 Diatkine on, 411  
 internal/external reality and, 848  
 myth of origins and, 1093  
 mythology and, 1096, 1308  
 ontogenesis and, 1197  
 Perron-Borelli on, 553  
 preconception and, 1299  
 primal scene and, 1310  
 unconscious fantasies and, 1817–1818  
 Primal horde. *See* Myth of origins; Primitive horde  
*Primal Law* (Atkinson), 1320  
 Primal Oedipus complex, 1186  
 Primal repression, 1050, **1308–1310**, 1483, 1485  
 Primal scene, **1310–1311**  
 combined parent figure and, 316  
 constructions and, 336  
 dead mother complex and, 369  
 deferred action and, 380  
 early Oedipus complex and, 1188  
 infantile sexual curiosity and, 829  
 invariant and, 872  
 perversion and, 1255–1256  
 primary narcissism and, 1110  
 primitive and, 1319  
 Róheim on, 1510  
 seduction scenes and, 1565–1566  
 sexual theories of children and, 1591  
 superego and, 1691  
 swastika and, 1023  
 “Wolf Man” case and, 336, 639, 650, 821, 829, 1310, 1565–1566  
 word-presentations and, 1874  
 Primal Scream therapy, 258  
 Primary (erotogenic) masochism, 517–518, 1021, 1022, 1125, 1130, 1315–1316, **1315–1316**, 1475  
 Primary anxiety, 90  
 Primary envy, 915  
 “Primary Femininity” (Stoller), 1660  
 Primary gain, 590, **664**  
 Primary genital stage, 5  
 Primary identification, 788–789, 790, 815, 869, 1028, **1313–1314**, 1799  
 Primary love, 152, 307, **1314–1315**, 1736  
*Primary Love and Psychoanalytic Technique* (Balint), 148, 1736  
 Primary masochism. *See* Primary (erotogenic) masochism  
 “Primary Maternal Preoccupation” (Winnicott), 247, 1029, 1582  
 Primary narcissism, **1110**  
 antinarcissism and, 97  
 Balint on, 148–149, 151, 1315  
 ego and, 466  
 infantile omnipotence and, 822  
 megalomania and, 1036  
 narcissistic defenses and, 1111  
 Oedipus complex and, 1186  
 pictogram and, 1286, 1287  
 sleep and, 1614  
 Winnicott on, 1107  
 Primary need, **1316**  
 Primary object, 24, 323, 369, **1317**, 1736, 1753–1754  
 Primary processes  
 binding/unbinding and, 179  
 condensation and, 324, 325  
 day’s residues and, 367  
 dreams and, 437, 438, 441, 442  
 free energy/bound energy and, 617  
 passage to the act and, 18  
 perceptual identity and, 1249  
 pleasure principle and, 1290, 1318  
 primitive words and, 4  
 taboo and, 1724  
*See also* Primary/secondary processes  
 Primary/secondary processes, **1317–1319**  
 Aulagnier-Spaurani on, 1328, 1840  
 constancy principle and, 1151  
 language and, 1874  
 perceptual identity and, 1249  
 prepsychosis and, 1305–1306  
 primal and, 1312  
 thought identity and, 1749  
 working over and, 1877–1878  
*Primer for Mothers* (Stekel), 1657  
*Primeval Instincts of Man, The* (Hermann), 307, 737  
 Primitive, 370, 434, 1098, **1319–1320**, 1748  
*See also* Animistic thought; Archaic; Magical thinking; Myth of origins; Omnipotence of thoughts; Primal; Totemism  
 Primitive agony, **1320**  
 “Primitive Emotional Development” (Winnicott), 843  
 Primitive horde, 1243–1244, 1319, **1320–1322**, 1768  
*See also* Myth of origins  
 Primitive-psychotic body image, 197–198  
 Primitive words, 3–4  
*Primitivo e locura* (Ramos), 214  
 Prince, Morton, 1672  
 Boston Psychoanalytic Society/Institute and, 206–207  
 Jones and, 892  
 Putnam and, 1424  
 U.S. psychoanalysis and, 1822  
 “Prince Hal’s Conflict” (Kris), 1598  
 Principle of constancy. *See* Constancy principle  
 Principle of identity preservation. *See* Identity preservation principle  
 Principle of inertia. *See* Inertia principle  
 “Principle of Relaxation and Neo-Catharsis” (Ferenczi), 1465  
 “Principles and Modalities of Functioning” (Quatrième Groupe). *See* “Blue Book”  
*Principles of Intensive Psychotherapy* (Fromm-Reichmann), 652, 1540–1541, 1850  
 Principles of mental functioning, **1325–1326**  
*See also* Pleasure principle; Reality principle

Volume 1, pp. 1–662; Volume 2, pp. 663–1344; Volume 3, pp. 1345–1892

- Principles of Psychoanalysis* (Nunberg), 1165
- Prinzhorn, Hanz, 1624
- Privacy of the Self, The* (Khan), 913, 1580
- Privation, 418, 653, **1326–1327**
- “Problem of the Animus, The” (Jung-Rauschenbach), 903–904
- “Problem of the End of Analysis, The” (Ferenczi), 494
- “Problem of the Genesis of Psychical Conflict, The” (Waelder), 1845
- Problemas del campo psicoanalítico* (Baranger and Baranger), 150
- “Problématique du Psycho-Somatique, La” (Parcheminey), 1236
- Problème de la destinée, Le* (The problem of destiny) (Allendy), 46
- Problems of Mysticism and Its Symbolism* (Silberer), 1608
- Problems of Neurosis: A Book of case Histories* (Adler), 1618
- Process, **1327–1329**
- Processes of development, **1329–1331**
- Prochiantz, Alain, 183
- Progress and Revolution* (Waelder), 1845
- “Progress in Analytic Technique” (Ferenczi), 1465
- Progressive neutralization, **1331**
- Prohibition, **1331–1332**
- “Project for a Scientific Psychology, A” (Freud), **1332–1334**
- on act/action, 9
- on adaptation, 22
- on attention, 127
- on binding/unbinding, 179
- on compulsion, 322
- on constancy principle, 1151, 1322
- on displacement, 421
- on dreams, 436
- on Eckstein case, 454
- on ego, 462
- ego psychology and, 486
- on experience of satisfaction, 536
- on facilitation, 543
- on free energy/bound energy, 617, 618
- on hallucinatory wish-fulfillment, 1865
- on helplessness, 734
- on hypercathexis, 767
- on illusion, 796
- on incompleteness, 805
- on inertia principle, 1324
- on internal/external reality, 847
- on jokes, 890
- Jokes and their Relation to the Unconscious* and, 891
- on lies, 971
- on maternal, 1027
- on memories, 1040
- on memory, 1042
- on mnemonic symbols, 1061, 1062
- on mnemonic traces, 1062, 1063, 1064
- on mythology, 1096
- neurophysiology and, 59, 213
- on pain, 1219, 1280, 1333
- on perception-consciousness system, 1248
- on perceptual identity, 1249
- on pleasure principle, 1325, 1332–1333
- on primary identification, 1313
- on primary object, 1317
- on primary/secondary processes, 1317, 1328
- on primitive, 1319
- on protective shield, 1340
- on proton-pseudos, 1342
- on psi system, 1345
- on psychic causality, 1353
- on psychic energy, 1355
- on psychic representative, 1358
- on psychology and psychoanalysis, 1397
- on quantitative/qualitative dimensions, 1427
- on reality principle, 1450
- on representation and, 781–782
- on screen memories, 1555
- on self-preservation, 1575
- on specific actions, 1638
- structural theories and, 1666
- on sum of excitation, 1689
- on symbolism, 1706–1707
- on systems, 32–33
- on Thing, 1743
- on thought, 1746–1747
- on topographical point of view, 1760
- on unconscious, 1818
- on word-presentations, 1873
- on working over, 1878
- Projection, **1334–1337**
- allergies and, 47, 48
- altruism and, 54
- animistic thought and, 85–86
- animus/anima and, 87
- certainty and, 265
- critical theory and, 31
- envy and, 509
- estrangement and, 524
- internal objects and, 850
- “participation mystique” and, **1337–1338**
- persecution and, 1252–1253
- phobias and, 1275
- psychological tests and, 1395
- psychotic defenses and, 1413
- self and, 1579
- splitting of the object and, 1642
- symptom-formation and, 1717
- symptoms and, 1715
- Projective duplication, 1198
- Projective identification, **1338–1340**
- aggression and, 34
- alpha function and, 51, 52
- anality and, 72, 1338
- archaic mother and, 113
- arrogance and, 121
- asthma and, 124
- beta-elements and, 171
- bizarre object and, 188
- breastfeeding and, 221
- claustrophobia and, 306
- container-contained and, 340
- counter-transference and, 350
- disavowal and, 417
- female sexuality and, 577
- hallucinoses and, 722–723
- heroic self and, 739–740
- infantile psychosis and, 826
- internal objects and, 850
- introjection and, 869–870
- negative capability and, 1123–1124
- nonverbal communication and, 1154
- paranoid-schizoid position and, 1233, 1338
- “participation mystique” and, 1779
- projection and, 1336
- psychotic defenses and, 1414
- purified-pleasure-ego and, 1423
- selected facts and, 953, 1123–1124, 1750
- splitting of the object and, 1642
- thought-thinking apparatus and, 1750
- Tomasi on, 1758–1759
- transference and, 1783
- Weiss on, 1854
- work of the negative and, 1129
- Prometheus, 299, 348, 1241, 1368
- Propaganda, 924–925
- Prophylaxis, 19
- “Proposal for a Regulating Institution for Psychoanalysts, A” (Leclaire), 957
- Prospero and Caliban: The Psychology of Colonization* (Mannoni), 1009

## INDEX

Volume 1, pp. 1–662; Volume 2, pp. 663–1344; Volume 3, pp. 1345–1892

- Prostitute, mother as, 342  
*Protective Shell in Children and Adults, The* (Tustin), 138  
 Protective shield, **1340–1342**  
 excitation and, 533  
 Freud on, 174, 533, 1340, 1341  
 maternal and, 1027  
 mnemonic traces and, 1062  
 pain and, 1219  
 Proto-mental phenomena, 711  
 Proto-thoughts, **1343**  
*Protocols of the Elders of Zion*, 1438  
 Proton-pseudos, 1313, 1333, **1342**  
 Proudhon, Pierre-Joseph, 1437  
 Proust, Marcel, 875, 986  
 Provotelle, R., 304  
 Prunes, Celestino, 215, 216, 1015  
 Pseudomaturity, 72  
*Pseudos*, 1555  
 Psi system, **1345**  
*Psicanálise na Educacao, A* (Morais), 214  
*Psicanalisi, La* (Morselli), 1076  
*Psiche*, 879, 881, 1252  
*Psicoanálisis de los sueños* (Garma). See *Psychoanalysis of Dreams*  
*Psicoanalisi*, 879  
*Psicoanálisis* (Peru), 1254  
*Psicoanálisis* (Venezuela), 1833  
 “Psicoanálisis, ciencia problemática” (Ortega y Gasset), 1637  
*Psicoanálisis y dialéctica materialista* (Bleger), 194  
*Psicoterapia*, 116  
*Psíquico y Naturaleza humana, Lo* (Matte-Blanco), 284  
*Psiquismo fetal, El* (Rascovsky), 1447  
*Psychanalyse: Ratsel des Unbewussten* (film), III:pl.1  
*Psychanalyse, doctrine et application, La* (Psychoanalysis: theory and application) (Allendy), 46  
*Psychanalyse, La*, 610, 935, **1347–1348**, 1619  
 “Psychanalyse, La: Son image et son public” (Moscovici), 611  
*Psychanalyse, La* (Delgado), 384  
*Psychanalyse à l’université*, 124  
*Psychanalyse à l’école, La* (Zulliger), 1888  
*Psychanalyse d’aujourd’hui, La* (Nacht), 1626  
*Psychanalyse des névroses et des psychoses, La* (Régis and Hesnard), 134, 607, 741, 1345, **1360–1362**, 1459  
*Psychanalyse du diable, La* (Dubal), 450  
*Psychanalyse et anthropologie* (Bonaparte), 200  
*Psychanalyse et apocalypse*, 241  
*Psychanalyse et biologie* (Bonaparte), 200  
*Psychanalyse et connaissance* (Dubal), 450  
*Psychanalyse et les névroses, La* (Allendy & Laforgue), 46, 305, 934, **1345–1346**  
*Psychanalyse et Pédiatrie* (Dolto-Marette), **1346–1347**  
*Psychanalyse infantile Symbolisme et valeur clinique des créations imaginatives chez l’enfant* (Morgenstern-Kabatschnik), 1073  
*Psychanalyse pour la Personne* (Caruso), 249  
*Psychanalyse précoce, La* (Diatkine), 411  
*Psychanalyse sans divan, Le* (Racamier et al.), 1435  
*Psychanalysten*, 314  
 Psychasthenia, 322, 1179  
 Psyche, **1348–1349**, 1650, 1665, 1680  
*Psyché, revue internationale de psychanalyse et des sciences de l’homme*, 290, **1349–1350**  
 Berge and, 161, 1350  
 Favez-Boutonier and, 559, 1350  
 French psychoanalysis and, 609  
 Hesnard and, 742, 1350  
 Laforgue and, 934  
 Mannoni and, 1009, 1350  
*Psyche and Eros*, 1608  
*Psyche. Zeitschrift für Psychanalyse und ihr Anwendungen*, 679, 1018, 1061  
*Psychiatre, son “fou” et la psychanalyse* (Mannoni), 456  
*Psychiatric Interview, The* (Sullivan), 1689  
*Psychiatrie de l’enfant, La. See Journal de la psychanalyse de l’enfant*  
 “Psychiatrie et psychanalyse: L’apport de la psychanalyse à la psychiatrie” (Cénac), 261  
*Psychiatrist and the Dying Patient, The* (Eissler), 490  
*Psychiatry*, 1688  
*Psychiatry and Anti-Psychiatry* (Cooper), 699  
 Psychic apparatus, **1351–1353**, 1379  
 Psychic birth, 185  
 Psychic body, 540  
 Psychic causality, **1353–1355**, 1719  
 Psychic energy, **1355–1356**  
 cathexis and, 259, 260  
 Freud-Jung split and, 1105  
 psychic apparatus and, 1352  
 working over and, 1878  
 See also Free energy/bound energy  
 Psychic envelopes, 739, 1020  
 Psychic fossilization, 1560  
 Psychic masochism, 153  
 Psychic pain. See Pain  
 Psychic reality, 439, **1356–1358**, 1819  
 Psychic representative, **1358**, 1433  
 Psychic structure, **1358–1359**  
 Psychic temporality, **1359–1360**, 1757  
 “Psychical, or Mental, Treatment” (Freud), 556, 1124, 1353  
 “Psychical Mechanism of Forgetfulness, The” (Freud), 596, 1351  
*Psychische Bedingtheit und psychoanalytische Behandlung organischer Leiden* (Groddeck), 705  
*Psycho-Analysis: A Brief Account of the Freudian Theory* (Low), 997  
 “Psycho-Analysis” (Freud), 321, 489, 531  
*Psycho-Analysis and Faith: The Letters of Sigmund Freud and Oskar Pfister*, 1601  
 “Psycho-Analysis and Telepathy” (Freud), 747, 1181, 1735  
 “Psycho-Analysis and the Establishment of the Facts in Legal Proceedings” (Freud), 107, 319, 616, 1560  
 “Psycho-Analytic Contribution to Aesthetics, A” (Segal), 1708  
 “Psycho-Analytic Notes on an Autobiographical Account of a Case of Paranoia (Dementia Paranoides)” (Freud). See Schreber case  
 “Psycho-Analytic Play Technique, The” (Klein), 1501  
 “Psycho-Analytic View of Psychogenic Disturbance of Vision, The” (Freud), 482–483, 1392, 1575  
*Psycho-Analytical Process, The* (Meltzer), 1783  
 Psycho-sociology, 1632  
*Psychoanalyse* (Belgium), 158  
*Psychoanalyse der Gesamtpersönlichkeit* (Psychoanalysis of the total personality) (Alexander), 42–43  
 “Psychoanalyse Freuds, Die” (Bleuler), 195  
*Psychoanalyse und ihre Anwendungen* (Simmel), 1612  
*Psychoanalyse und Logik* (Hermann), 737  
*Psychoanalyse und Synthese der Existenz* (Caruso), 134  
 Psychoanalysis, **1362–1366**  
*Psychoanalysis*, 1380  
 Psychoanalysis  
 defined, 1362–1365  
 purpose of, 20  
 “Psychoanalysis” (Janet), 886  
*Psychoanalysis and Culture* (Lorand), 991

Volume 1, pp. 1–662; Volume 2, pp. 663–1344; Volume 3, pp. 1345–1892

- Psychoanalysis and Feminism* (Mitchell), 576  
 “Psychoanalysis and Pedagogy” (Ferenczi), 580, 971  
*Psychoanalysis and Politics* (Money-Kyrle), 1070  
 “Psychoanalysis and Telepathy” (Servadio), 1586  
 “Psychoanalysis Applied to Education” (Porto-Carrero), 1295  
 “Psychoanalysis in Its Relations with Child Psychology” (Piaget), 1282  
*Psychoanalysis of Children, The* (Klein), 4, 74, 281, **1366**  
*Psychoanalysis of Dreams* (Garma), 666, **1366–1367**  
*Psychoanalysis of Fire, The* (Bachelard), 145, **1367–1368**  
 “Psychoanalysis of Primitive Cultural Types” (Róheim), 1510  
 “Psychoanalysis of the Family” (Flugel), 697  
*Psychoanalysis of the Prostitute* (Choisy), 290  
 “Psychoanalysis of the Psychoanalytic Frame” (Bleger), 606  
*Psychoanalysis of War, The* (Fornari), 598  
 Psychoanalyst role, **1368–1369**  
 abstinence rule, 7–8, 11, 1385, 1786  
 analysand and, 74–75  
 analysand aspiration to, 77, 122  
 analytical psychology on, 79  
 anticipatory ideas and, 95–96  
 attention and, 127, 128  
 benevolence and, 8, 531, 1144  
 boredom and, 203  
 boundary violations and, 209–210  
 change and, 268  
 child analysis and, 1733  
 contact and, 338–339  
 contradiction and, 341  
 direct analysis and, 414  
 evenly-suspended attention and, 530–531, 655, 1299, 1368, 1384  
 Ferenczi on, 160, 268  
 Filipino psychoanalysis and, 1268  
 listening and, 984  
 mutative interpretation and, 1089–1090  
 neutrality and, 339, 531, 1143–1144  
 non-selectivity, 127  
 preconception and, 1299  
 relaxation psychotherapy and, 1466  
 tact and, 1725–1726, 1729  
 therapeutic alliance and, 1732, 1733, 1740–1741  
 See also Counter-transference; Psychoanalytic treatment; Transference  
*Psychoanalytic Approach to Juvenile Delinquency, The* (Friedländer-Fränk), 646  
 Psychoanalytic Association of France. See Association psychanalytique de France  
 “Psychoanalytic classification of character pathology, A” (Kernberg), 270, 273  
 Psychoanalytic Consortium, 58, 59  
*Psychoanalytic Dialogue: The Letters of Sigmund Freud and Karl Abraham, A*, 1601  
*Psychoanalytic Education in the United States* (Ross and Lewin), 1516  
 Psychoanalytic epistemology, **1369–1371**  
 Psychoanalytic family therapy, **1371–1372**  
 Psychoanalytic filiations, **1372–1374**  
 Psychoanalytic Institute, 1557  
 Psychoanalytic Institute of New England (PINE), 208  
 Psychoanalytic Institute of Northern California, 1531  
*Psychoanalytic Method and the Doctrine of Freud* (Dalbiez), 363, 539  
 Psychoanalytic nosography, **1374–1375**  
*Psychoanalytic Quarterly, The*, **1377–1378**, 1498  
 Psychoanalytic research, **1378–1379**  
*Psychoanalytic Review, The*, 889, **1379–1380**  
*Psychoanalytic Revolution, The: The Life and Work of Sigmund Freud*, 611  
 Psychoanalytic semiology, **1380–1381**  
*Psychoanalytic Situation: An Examination of Its Development and Essential Nature, The* (Stone), 1661  
*Psychoanalytic Studies of the Personality* (Fairbairn), 545  
*Psychoanalytic Study of the Child, The*, 492, 728, 925, **1381–1383**  
 “Psychoanalytic Theory and the Mind-Body Problem” (Rubinstein), 1517  
*Psychoanalytic Theory of Neurosis, The* (Fenichel), 270, 579, **1383**  
 Psychoanalytic Training and Research Center. See Centre de formation et de recherches psychanalytiques  
 Psychoanalytic Training Institute (Berlin), 6  
 Psychoanalytic treatment, **1383–1386**, **1728–1731**  
 active technique, 8, 15–16, 407, 581, 607, 640, 923, 1729  
 acute psychoses and, 22  
 allergies and, 48  
 in analytical psychology, 79  
 analyzability and, 81, 1787  
 basic fault and, 152  
 capacity to be alone and, 246  
 change and, 257, 267–268  
 constructions and, 335–338  
 cure and, 358–359, 1385, 1777, 1787  
 definition of psychoanalysis and, 1363  
 derivatives of the repressed and, 1484  
 directed daydreams and, 414–415, 1494  
 dream interpretation, 438–439  
 dream-like memory and, 439  
 ego psychology and, 487  
 elasticity and, 494, 581  
 ethics and, 525  
 face-to-face situation and, 541–542, 1412  
 fantasy and, 554  
 frame of, 606–607, 1405, 1412, 1732  
 grid and, 704, 705  
 guilt and, 718  
 holding and, 754  
 id and, 779  
 identification and, 790  
 identification fantasies and, 791  
 incompleteness and, 805–806  
 indications/contraindications for, 808–809  
 initial interview and, 834–836  
 insight and, 836–837  
 lifting of repression and, 1486–1487  
 “Lines of Advance in Psycho-Analytic Therapy” on, 979–980  
 Marty on, 1016  
 mastery and, 1024  
 memories and, 1041–1042  
 multilingualism and, 1086  
 Nacht on, 1102–1103  
 negative therapeutic reaction and, 359, 1125–1127, 1219, 1469–1470  
 over-interpretation and, 1217  
 patient physical position in, 541–542, 835, 990  
 payment for, 1068–1069, 1732  
 psychotherapy and, 1411–1413  
 Rank on, 1445  
 “Recommendations to Physicians Practicing Psychoanalysis” on, 127, 531, 1068, 1181, 1456–1457, 1490, 1729  
 regression and, 160  
 relaxation principle/neo-catharsis and, 1464–1465  
 repetition compulsion and, 1475  
 representation and, 782–783  
 repression and, 1479–1480  
 resolution of the transference, 1490–1491  
 silence and, 1610–1611  
 transgression and, 1791  
 vertex and, 1833–1834

## INDEX

Volume 1, pp. 1–662; Volume 2, pp. 663–1344; Volume 3, pp. 1345–1892

- working-off mechanisms and, 1877  
 See also Child analysis; Free association; Interpretation; Lay analysis; Psychoanalyst role; “Remembering, Repeating and Working-Through”; Resistance; Termination of treatment  
 “Psychoanalytic Treatment of Narcissistic Personality Disorders, The” (Kohut), 605, 785, 920, 1059, 1574  
*Psychoanalytical Treatment of Children, The* (Anna Freud), 833, **1386–1387**  
*Psychoanalyticky sbornik*, 361  
*Psychoanalytische Method, Die* (Pfister), 1260  
*Psychoanalytische Volksbuch, Das* (Federn and Meng), 568, 1044  
*Psychoanalyzing* (Leclaire), 957  
 Psychobiography, **1388–1389**, 1402, 1743–1745, 1841  
*Psychobiology: A Science of Man* (Meyer), 1053  
 Psychodermatology, 1613  
*Psychodiagnostics* (Rorschach), 1513  
 Psychodrama  
 Aberastury’s use of, 5  
 analytic psychodrama, 77–79  
 cathartic method and, 258  
 French psychoanalysis and, 610  
 Kestemberg-Hassin on, 911  
 Moreno on, 1072  
*Psychodrame psychanalytique, Le* (Kestemberg-Hassin and Jeammet), 911  
 “Psychogenesis of a Case of Homosexuality in a Woman, The” (Freud), 757, 817, **1389–1391**  
 Psychogenesis/organogenesis, **1391–1392**  
 Psychogenic blindness, **1392–1393**  
 Psychogeny, Lacan on, 37  
 Psychohistory, 511, 986, 1293, **1393–1394**  
*Psychohistory Review, The*, 1394  
 “Psychological Analysis of the Causes of War, A” (Money-Kyrle), 1070  
 “Psychological Aspects of International Affairs, The” (Waelder), 1845  
*Psychological Aspects of War and Peace* (Waelder), 1845  
*Psychological Birth of the Human Infant, The* (Mahler-Schönberger), 1002  
 Psychological tests, 1087, **1394–1395**, 1398  
 Psychological types, **1395–1397**  
*Psychological Types* (Jung), 86, 812, 902, 1396  
*Psychologie* (Algeria), 1155  
 “Psychologie, La” (Piaget), 1669  
*Psychologie Collective*, 1537  
*Psychologie de la Colonisation* (Mannoni), 549  
 “Psychologie de la Vie Quotidienne” (Chentrier), 276  
*Psychologie des Foules* (Le Bon), 556, 1685  
*Psychologie des Säglings* (Bernfeld), 169  
 “Psychologie génétique et psychanalyse” (Saussure), 1536  
*Psychologie vom empirischen Standpunkt* (Brentano), 222  
*Psychologies des rêves éveillés, La* (Varendonck), 157  
 Psychology and psychoanalysis, 62–63, **1397–1398**  
*Psychology of Anti-Semitism, The* (Hermann), 737  
*Psychology of Dementia Praecox* (Jung), 902, **1398–1399**  
*Psychology of Insanity, The* (Hart), 696  
*Psychology of Nationhood, The* (Strachey), 1664  
 “Psychology of the Individual” symposium (Brussels, 1954), 134  
*Psychology of the Transference, The* (Jung), 902, 1779  
 “Psychology of the Unconscious, The” (Jung), 1337, **1399–1400**  
*Psychology of Women, The. A Psychoanalytic Interpretation* (Deutsch-Rosenbach), 405, **1400–1401**  
 Psychoneuroses. See Neuroses; Transference neuroses  
 “Psychopathic Characters on the Stage” (Freud), 351, 985, 1215  
*Psychopathologie de l’échec* (Laforgue), 544, 934, **1401–1402**  
*Psychopathologie du bébé, La* (Lebovici and Weil-Halpern), 955  
*Psychopathology of Everyday Life, The* (Freud), **1402–1403**, 1551, 1686  
 on Bernays-Freud, Minna, 168  
 on castration complex, 251  
 Claude on, 304  
 cryptomnesia and, 356–357  
 on déjà vu, 381  
 on estrangement, 524  
 on forgetting, 596  
 on illusion, 796  
 Jankélévitch and, 887  
 on language, 942  
 on masochism, 1021  
 on negative hallucination, 1124  
 on parapraxes, 1235  
 publication of, 638  
 on *Revista de psiquiatria y disciplinas conexas*, 1497  
 on Schiller, 1539  
 on slips of the tongue, 1615  
 on time, 1757  
 on wishes, 1867  
 Psychopharmacology, 1528, 1540  
 Psychoses, **1403–1405**  
 acute, 21–22  
 anal-sadistic stage and, 74  
 arrogance and, 121  
 attacks on linking and, 983–984  
 autoeroticism and, 141  
 autoplasmic behavior and, 144  
 blank, 191–192  
 body image and, 197–198  
 constructions and, 338  
 counter-transference and, 350  
 death instinct and, 373  
 as developmental disorders, 408  
 differential diagnosis, 36–37  
 disintegration anxieties and, 418  
 ego states and, 489  
 Federn, Paul on, 487–488, 568  
 fetishism and, 583  
 forgetting and, 596  
 Garma on, 665  
 gaze and, 990  
 hallucinatory wish-fulfillment and, 1866  
 hallucinosis and, 722–723  
 infantile, 823–827  
 internal/external reality and, 847  
 introjection and, 871  
 Katan on, 907  
 Lacan on, 36–38, 192, 1404, 1405  
 memory and, 1043  
 narcissism and, 1105, 1106  
 narcissistic neuroses and, 1113  
 need for causality and, 1119  
 negative hallucination and, 1124–1125  
 obsessional neurosis and, 1180  
 organic, 1206  
 panic and, 1416  
 perversion and, 1258  
 pictogram and, 1285  
 primal and, 1313  
 primitive agony and, 1320  
 protective shield and, 1341–1342  
 psychic structure and, 1359  
 psychic temporality and, 1360  
 psychoanalytic nosography and, 1375  
 psychosis/neurosis distinction, 1414–1416

Volume 1, pp. 1–662; Volume 2, pp. 663–1344; Volume 3, pp. 1345–1892

- psychotic potential and, 1417–1418  
 puerperal, 1421–1422  
 Racamier on, 1421–1422, 1435–1436  
 Rosenfeld, Herbert on, 1514  
 self-representation and, 1578  
 sense/nonsense and, 1585  
 signifier/signified and, 1606  
 suicide and, 1687  
 symptoms and, 1715  
 time and, 1758  
 transference and, 487, 568, 1405, 1419  
 Psychosexual development, 79, 326, **1405–1407**  
*See also* Infantile sexuality; Libidinal development  
*See also specific stages*  
*Psychosexuelle Differenz der Hysterie und der Dementia Praecox* (Psychosexual Differences between Hysteria and Dementia Praecox) (Abraham), 6  
 “Psychosis and Child Care” (Winnicott), 1287  
 Psychosis/neurosis distinction, **1414–1416**  
 Psychosomatic economy, 420  
 Psychosomatic limit, **1409–1410**  
*Psychosomatic Medicine*, 43  
 Psychosomatic School of Paris. *See* École psychosomatique de Paris  
 Psychosomatics, **1407–1409**  
 actual vs. defense neuroses and, 20  
 Alexander, Franz Gabriel on, 43, 208, 1408–1409  
 allergic object relationship and, 47  
 allergies and, 47  
 asthma and, 124, 125  
 body image and, 198  
 Boston Psychoanalytic Society/Institute and, 208  
 Chicago Psychoanalytic Institute and, 278  
 conflict and, 326  
 conversion and, 345, 1409  
 excitation and, 534  
 French psychoanalysis and, 610  
 instincts and, 838  
 Jelliffe on, 889  
 Marty on, 610, 1016, 1198, 1407, 1408, 1409  
 mentalization and, 1046  
 narcissistic neuroses and, 1114  
 operational thinking and, 1198  
 Perestrello, Danilo and, 1250  
 state of being in love and, 1656  
 ulcerative colitis and, 1813–1814  
*Psychotherapia*, **1411**  
*Psychotherapja* (Croatia), 1884  
*Psychothérapie de l'adolescent* (Mâle), 1004  
 “Psychothérapie des schizophrènes, La” (Perrier), 1251  
*Psychothérapie et Psychanalyse* (Held), 731  
*Psychothérapies, Les* (Berge), 162  
 Psychotherapy, **1411–1413**  
 Control-Mastery Theory and, 1532  
 face-to-face situation and, 541, 1412  
 relaxation and, 1465–1466  
*See also* Psychodrama  
 Psychotic anxiety, 90  
 Psychotic defenses, **1413–1414**  
 Psychotic panic, 722, **1416**  
 Psychotic part of the personality, **1416–1417**  
 Psychotic potential, **1416–1419**  
*Psychotic States* (Rosenfeld), 1515  
 Psychotic transference, **1419**  
 Psychotropic drugs, 1117  
*Psyke*, 188  
 Psykoanalytisk Samfund (Denmark), 1698  
*Pszichoanalizis, mint módszer* (Hermann), 737  
 Puberty, **1419–1421**  
 adolescence and, 26  
 alcoholism and, 41  
 proton-pseudos and, 1342  
 seduction theory and, 1420, 1592  
 suicide and, 1687  
*See also* Adolescence  
 Pubic hair, 574  
 Puerperal psychoses, **1421–1422**, 1435–1436, 1618  
 Pujol, René, 122  
 Punishment, need for, **1120–1121**, 1126, 1577–1578  
 Punishment dreams, **1422–1423**, 1577  
 Puppet therapy, 1442  
 Purified-pleasure-ego, 850, **1423**  
 “Purloined Letter, The” (Poe), 1669  
 Purposive idea, **1424**  
*Pursued* (film), 293  
 Putnam, James Jackson, **1424–1425**  
 American Psychoanalytic Association and, 207, 227, 1425, 1823  
 Boston Psychoanalytic Society/Institute and, 206–207  
 photograph of, III:pl.3  
 on sublimation, 1679  
 U.S. psychoanalysis and, 1822, 1823  
 Putnam, Marian C., 208, 1444, 1809  
 Putnam Children’s Center, 208  
 Puysegur, Armand de, 84–85  
*Psychoanalytische Bewegung, Die*, 861, **1387–1388**  
 Pythagoras, 381, 1348  
**Q**  
 Qualitative dynamics, 727  
 Quantitative/qualitative dimensions, **1427–1429**  
 Quantum physics, 401, 1064  
 Quasi-independence/transitional stage, **1429**  
 Quatrième Groupe (Fourth Group) (OPLF), **1429–1431**  
 Aulagnier-Spairani and, 129, 529, 611, 807, 1429, 1430, 1645  
*Confrontation* and, 327  
 Enriquez-Joly and, 506  
 fourth analysis and, 602–604, 611  
*Inconscient, L’* and, 807  
 Perrier and, 611, 807, 1251, 1429–1430, 1645  
 Smirnov and, 1617  
 Société psychanalytique de Paris and, 1626  
 supervised analysis and, 1693  
*Topique* and, 529, 807, 1430, 1759  
 “Quelques aperçus sur l’expression du sentiment de culpabilité dans les rêves des enfants” (Morgenstern-Kabatschnik), 1073  
*Qu’est-ce que la suggestion?* (Baudouin), **1431–1432**  
*Question of Lay Analysis, The* (Freud), 951, **1432–1433**  
*Confrontation* and, 328  
 on definition of psychoanalysis, 1364  
 on female sexuality, 365  
*Future of an Illusion, The* and, 660  
 on multidisciplinary interactions, 108  
 on psychic apparatus, 1352  
 publication of, 802  
 Reik and, 1432, 1463  
 splits in psychoanalysis and, 1644  
 on U.S. psychoanalysis, 1823  
 on “wild analysis”, 1861  
 “Question of the Psychological Types, The” (Jung), 538  
*Questionamos*, 216  
 Quijada, Herman, 315, 1832  
 Quinidoz, Danièle, 1701  
 Quinidoz, Jean-Michel, 1701  
 Quiniou, Yolaine, 1304  
 Quota of affect, 786, 1428, **1433–1434**, 1875

## INDEX

Volume 1, pp. 1–662; Volume 2, pp. 663–1344; Volume 3, pp. 1345–1892

**R**

- Rabain, Jean-François, 1476, 1500  
 Rabanal, César Rodríguez, 1254  
 Rabaud, Étienne, 424  
 Racamier, Paul-Claude, **1435–1436**  
   on ambivalence, 57  
 Congrès des psychanalystes de langue française des pays romans and, 330–331  
 on delusions, 385  
 on hermeneutics, 738  
 on incest, 804  
 on infantile psychosis, 825  
 Nacht and, 1102, 1435  
 on paradox, 434, 1225, 1226  
 on parenthood, 1237  
 on postnatal depression, 1298  
 on psychogenesis, 610  
 on psychoses, 1421–1422, 1435–1436  
 on tenderness, 1736  
 on weaning, 1852  
 Racine, Yves, 1766  
 Racism, **1436–1437**  
   cinema and, 294  
   Fanon on, 549–550  
   Kardiner on, 907  
   Mauco on, 1035  
   narcissism of minor differences and, 1109  
 Racker, Heinrich, **1439–1440**  
   Argentinian psychoanalysis and, 117–118, 119  
   Brazilian psychoanalysis and, 911, 1015  
   on change, 268  
   on counter-transference, 1440, 1778  
   on empathy, 502  
   Kemper, Werner Walther and, 910  
 Radin, Paul, 1321  
 Radó, Sándor, **1440–1442**  
   Abraham, Karl and, 5  
   on addiction, 23  
   on alcoholism, 42  
   American Academy of Psychoanalysis and, 58  
   Berliner Psychoanalytische Poliklinik, 675  
   Berliner Psychoanalytisches Institut and, 166  
   Burrow and, 238  
   Croatian psychoanalysis and, 1884  
   on dipsomania, 413  
   Fenichel and, 579, 1441  
   Ferenczi and, 329  
   Happel and, 725  
   Hartmann and, 727, 1441  
   Heimann and, 730  
   Hungarian psychoanalysis and, 580, 765  
   Hungarian School and, 764  
   International Federation of Psychoanalytic Societies and, 852  
   *Internationale Zeitschrift für Psychoanalyse* and, 860, 1441  
   Kardiner and, 906, 907  
   on melancholia, 1039  
   New York Psychoanalytic Institute/Society and, 1147, 1823  
   Schultz-Hencke and, 1547  
   U.S. psychoanalysis and, 1825  
 Raffalovitch, Marc-andré, 743  
 Raimbault, Émile, **1442**  
 Raimbault, Ginette, 129, 1243, 1442  
 Rajka, Theodor, 1446  
 Rajka, Tibor, 766  
 Rallo Romero, José, 1296  
 Rambert, Madeleine, **1442–1443**, 1701  
 Ramirez, Santiago, 566, 1051, 1052  
 Ramos, Arthur, 214  
 Ramuz, Charles Ferdinand, 561  
 Rand, Nicholas, 1765  
 Ranefeld, Johannes, 135  
 Rangell, Leo, 131, 857, 992, 1137  
 Rank, Otto, **1444–1446**  
   anaclitic depression and, 70  
   anthropology and, 93  
   on applied psychoanalysis, 108  
   on birth, 185  
   on birth dreams, 186  
   on birth trauma, 124, 253, 641, 833, 834, 1802–1803  
   on castration complex, 254  
   definition of psychoanalysis and, 1363  
   Deuticke and, 404  
   *Development of Psycho-Analysis*, 407, 580–581, 979–980  
   on double, 429, 434, 1106, 1815  
   on dreams, 443  
   First World War and, 586  
   *Gesammelte Schriften* and, 680  
   Heller and, 732  
   *Imago* and, 107, 800, 802, 1445  
   *Inhibitions, Symptoms, and Anxiety* and, 833, 834  
   International Psychoanalytical Association and, 854, 1445  
   *Internationale Zeitschrift für Psychoanalyse* and, 860  
   Internationaler Psychoanalytischer Verlag and, 49, 861, 1445  
   Jankélévitch and, 887  
   Jones on, 651  
   Kantianism and, 905  
   Kardiner and, 906  
   Laforge and, 933  
   “Lines of Advance in Psycho-Analytic Therapy” and, 979–980  
   on melancholia, 1082  
   *Minutes of the Vienna Psychoanalytic Society* and, 1057–1058  
   *Moses and Monotheism* and, 1077  
   on mother-infant bond, 232  
   on mythology, 443, 1093–1094, 1095  
   on narcissism, 1190–1191  
   on neutrality, 1144  
   Nin and, 1150, 1443  
   Nunberg and, 1165  
   photograph of, III:pl.4,9  
   on prehistory, 1303  
   on psychic causality, 1354  
   on psychoanalytic treatment, 1384, 1729  
   *Psychotherapia* and, 1411  
   psychotherapy and, 1412  
   Rank-Minzer and, 1443  
   on repression, 1485  
   Sachs and, 1523  
   Schmidt, Vera and, 1544  
   Secret Committee and, 1445, 1561, 1562  
   on signal anxiety, 1604  
   Sokolnicka and, 1633  
   splits in psychoanalysis and, 1643  
   Sterba and, 1658  
   on termination of treatment, 1738  
   on training analysis, 1769  
   on transference, 407  
   on visual arts, 1842  
   Weininger and, 1587  
   Wiener psychoanalytische Vereinigung and, 1444, 1857  
   Wilbur and, 1859–1860  
 Rank-Minzer, Beata, 207, 208, **1443–1444**  
 Ranschburg, Paul, 1721  
 Raoul-Duval, Anne, 1297  
 Rapaport, Danièle, 764  
 Rapaport, David, **1446–1447**  
   cognitivism and, 309  
   on ego autonomy, 474  
   ego psychology and, 466  
   on ego states, 488  
   Hartmann and, 488  
   Rubinstein and, 1517  
 Rapaport, Samuel, 1446

Volume 1, pp. 1–662; Volume 2, pp. 663–1344; Volume 3, pp. 1345–1892

- Raphael-Leff, Joan, 577
- Rappard, Philippe, 1766
- Rascovsky, Arnaldo, **1447–1448**
- Alvarez de Toledo and, 55
- Argentinian psychoanalysis and, 117, 118, 1447–1448
- Colombian psychoanalysis and, 315
- Federación psicoanalítica de América latina and, 566
- Martins, Cyro and, 1015
- Pichon-Rivière and, 1284
- Revista de psicoanálisis*, 1496
- Rascovsky, Matilde, 55, 1447
- Rasmussen, Elisabeth Goode, 666
- Rassial, Jean-Jacques, 1421
- “Rat Man” case, 944–945, **1160–1162**
- ambivalence and, 56
- archeological metaphors and, 114
- case history process and, 250
- cathartic method and, 258
- compulsion and, 322
- constructions and, 336
- delusions and, 791
- developmental disorders and, 408
- doubt and, 435
- Fluss and, 595
- frame of psychoanalytic treatment and, 639
- identification and, 787
- infantile neurosis and, 821
- inferiority feelings and, 831
- instinctual impulse and, 840
- intellectualization and, 844
- International Psychoanalytical Association and, 854
- isolation and, 875–876
- mastery and, 1025
- negation and, 1121
- nuclear complex and, 1164
- obsessional neurosis and, 821, 1178, 1179
- Oedipus complex and, 1161, 1184
- omnipotence of thoughts and, 1189, 1339, 1748
- “On the Sexual Theories of Children” and, 1195
- on organic repression, 1207
- patient physical position and, 541
- premonitory dreams and, 1305
- projective identification and, 1339
- psychoanalytic treatment and, 1384, 1729
- sadism and, 1525
- sadomasochism and, 1527
- screen memories and, 1555
- sense of smell and, 1616
- Silberstein and, 1609
- stages and, 1652
- structuralism and, 1669
- symbolism and, 1712
- therapeutic alliance and, 1740
- undoing and, 1822
- Rathbun, C., 1640
- Rationalization, 368–369, 892, **1448**, 1559
- Ray, Man, 1695
- Ray, Robert B., 296
- Raymond, Fulgence, 304, 886
- Rayner, Eric, 1816
- Reaction-formations, **1448–1450**
- alcoholism and, 41
- anticathexes and, 94, 1449
- desexualization and, 398
- negative transference and, 1127
- rivalry and, 1507
- sublimation and, 1449, 1679
- substitute formations and, 1449, 1681
- turning around and, 1806
- urethral eroticism and, 517
- Reading “Capital”* (Althusser), 53
- Real, Symbolic, and Imaginary father, **1452–1453**
- Real, the, **1453–1455**
- death instinct and, 372
- ethology and, 528
- Ferenczi and, 1739
- internal/external reality and, 848
- privation and, 1327
- See also* Borromean knot
- Real father, 1452
- Real trauma, 318, **1455**
- Realangst*. *See* Realistic anxiety
- “Realidad exterior y los instintos en la esquizofrenia” (Garma), 666
- “Réalisation de désir et de symbolisme dans le conte” (Riklin), 443
- Realistic anxiety, 102, 447, 563
- “Realität und das Es in der Schizophrenie, Die” (Garma), 665
- Reality ego. *See* Pleasure ego/reality ego
- Reality principle, 1325–1326, **1450**
- act/action and, 9
- Bion on, 952
- conflict and, 326
- conscious processes and, 333
- death instinct and, 371
- ego and, 464
- ego-instincts and, 483
- experience of satisfaction and, 536
- frustration and, 653
- hallucinatory wish-fulfillment and, 1450, 1866
- historical reality and, 748
- humor and, 763
- hypercathexis and, 767
- identity and, 795
- mythology and, 1095
- pleasure principle and, 1291, 1450
- primary/secondary processes and, 1318
- projection and, 1336
- representation and, 551
- self-preservation and, 1575
- transgression and, 1792–1793
- transitional phenomena and, 1794
- Reality testing, **1450–1451**
- depressive position and, 396
- dreams and, 1048
- experience of satisfaction and, 536
- groups and, 710
- illusion and, 797, 798
- object loss and, 99
- truth and, 1804
- Realization, **1451–1452**
- “Realization symbolique, La” (Sechehaye), 1709–1710
- Reassurance, 1274
- Rebus, 942
- Recalled memory, 439
- Rechart, Eero, 584
- Reciprocal paths of influence, **1455–1456**
- Recognition, 53
- “Recommendations to Physicians Practicing Psychoanalysis” (Freud), 1068, **1456–1457**, 1729
- on attention, 127, 531
- on resolution of the transference, 1490
- on telepathy, 1181, 1457
- Reconstruction, 169, **336–337**
- See also* Constructions
- Redlich, Emil, 843
- Rée, Paul, 83
- Rees, John Rawlings, **1457–1458**
- British psychoanalysis and, 699
- Main and, 1003
- Psyché* and, 1350
- Tavistock Clinic and, 1457–1458, 1728
- Refente*, 1649
- “Reflections on the Concept of Mathesis” (Desanti), 1552
- Reflexes, 307, 1324, 1736
- “Réflexions sur la Valeur Scientifique et Morale de la Psychanalyse” (Ey), 363, 539
- Refoulement, Le* (Le Guen), 1479, 1480, 1481



## INDEX

Volume 1, pp. 1–662; Volume 2, pp. 663–1344; Volume 3, pp. 1345–1892

- Régis, Emmanuel Jean-Baptiste Joseph, **1458–1459**  
 Breton and, 223  
 on claustrophobia, 306  
 French psychoanalysis and, 607  
 Hesnard and, 741  
 on phobias, 1272, 1273  
*Psychanalyse des névroses et des psychoses, La*, 134, 607, 741, 1345, 1360–1362, 1459
- Regression, **1459–1460**  
 addiction and, 23  
 alcoholism and, 41  
 allergies and, 48  
 amphimixia and, 66–67  
 analytical psychology on, 79  
 anorexia nervosa and, 91  
 basic fault and, 152  
 benign/malignant, 160–161  
 character and, 273  
 choice of neurosis and, 288  
 disorganization and, 420, 421  
 ego states and, 489  
 exhibitionism and, 535  
 false self and, 547  
 Ferenczi on, 160, 581, 1739  
 fetishism and, 583  
 fixation and, 588, 1460  
 groups and, 710  
 identification and, 788  
 imago and, 800  
 libido and, 968, 1460  
 maternal and, 1028  
 maternity and, 1298  
 narcissistic withdrawal and, 1116, 1117  
 neurotic defenses and, 1142  
 obsessional neurosis and, 1179  
 psychic temporality and, 1360  
 psychoses and, 1404  
 repetition and, 1473  
 representability and, 1477  
 rituals and, 1504  
 sleep/wakefulness and, 1614  
 stages and, 1652  
 suicide and, 1687  
 symbolic realization and, 1709  
 true/false self and, 1582  
 weaning and, 1852  
 Winnicott on, 1460, 1709, 1862  
 “Régression et instinct de mort” (Marty), 420–421  
 “Régressions impossibles, Les?” (Aisenstein), 1460  
 Reich, Annie, **1460–1461**  
 Czech psychoanalysis and, 360, 361  
 Dosuzkov and, 432  
 Jacobson and, 883  
*Journal of the American Psychoanalytic Association*, 897  
 on termination of treatment, 1737  
 Reich, Wilhelm, **1461–1462**  
 Argentinian psychoanalysis and, 117  
 Berliner Psychoanalytisches Institut and, 166  
 Bernfeld on, 169  
 Brazilian psychoanalysis and, 217  
 on character, 270, 271, 272, 273  
 Danish psychoanalysis and, 390, 391  
 Dubal and, 450  
 French psychoanalysis and, 612  
 Fromm and, 651  
 on indications/contraindications for psychoanalysis, 809  
 Lehrinstitut der Wiener psychoanalytischen Vereinigung, 959  
 Marxism and, 1017–1018, 1023  
 Nazi Germany and, 675–676, 1018, 1022–1023, 1461  
 Norwegian psychoanalysis and, 1157  
 on orgasm, 1210  
 on orgone energy, 1210–1211  
 photograph of, III:pl.5  
 on politics, 1293  
 on psychic causality, 1354  
 on psychic energy, 1352  
 on psychoanalytic treatment, 1729  
 Radó and, 1441  
 Reich, Annie and, 1461  
 on relaxation principle/neo-catharsis, 1465  
 on resistance, 487  
 Russian/Soviet psychoanalysis and, 1518–1519  
 on silence, 1610  
 sociology and, 1632  
 splits in psychoanalysis and, 1643  
 Sterba and, 1659  
 Swedish psychoanalysis and, 1698  
 on termination of treatment, 1737  
 Vienna Ambulatorium and, 959  
 Vienna Seminar on Sexology and, 176  
 Wiener psychoanalytische Vereinigung and, 1857, 1858  
*Zeitschrift für psychoanalytische Pädagogik* and, 1886  
 Reichenbach, Hans, 169  
 Reichenstein, Eva, 285  
 Reider, Norman, 1529, 1530  
 Reiff, Philip, 1826  
 Reik, Theodor, **1462–1463**  
 Abraham, Karl and, 5, 1462, 1463  
 anthropology and, 93  
 on applied psychoanalysis, 108  
 Belgian psychoanalysis and, 157  
 Berliner Psychoanalytisches Institut and, 166  
 Burlingham and, 236  
 Dostoyevsky and, 432  
 on dreams, 443  
 Dutch psychoanalysis and, 1133  
 Eissler-Selke and, 492  
 on evenly-suspended attention, 531  
 Garma and, 117, 665  
 Heimann and, 730  
 Heller and, 732  
 on identification, 788  
 on *Jokes and their Relation to the Unconscious*, 892  
 lay analysis and, 951, 1118, 1432, 1463, 1558  
*Minutes of the Vienna Psychoanalytic Society* and, 1058  
 on music, 1088  
 on mythology, 443, 1093  
 National Psychological Association for Psychoanalysis and, 1118, 1146  
 on paranormal phenomena, 1181  
 on parenthood, 1237  
 photograph of, III:pl.5  
*Psychoanalysis* and, 1380  
*Psychoterapia* and, 1411  
 on religion, 899  
 on Shakespeare, 1597  
 splits in psychoanalysis and, 1643–1644  
 U.S. psychoanalysis and, 1824  
 Vienna Ambulatorium and, 959  
 Reinach, Salomon, 1000  
 Rejection, 101, 394–395, 1286  
 “Relation d’emprise, La” (Dorey), 1024  
 “Relation of Beating Fantasies to a Daydream, The” (Anna Freud), 1258  
*Relations between the Ego and the Unconscious, The* (Jung), 812  
 Relations model, **1464**  
 Relaxation principle/neo-catharsis, 15, 16, 407, **1464–1465**  
 Relaxation psychotherapy, **1465–1466**  
 Religion, **1466–1467**  
 animistic thought and, 86  
 archetypes and, 115  
 Arlow on, 119

Volume 1, pp. 1–662; Volume 2, pp. 663–1344; Volume 3, pp. 1345–1892

- Austrian psychoanalysis and, 134  
 Beirnaert and, 156  
 belief and, 158, 159  
 bisexuality and, 186  
 Brentano and, 223  
 certainty and, 265–266  
 Choisy and, 290  
*Civilization and Its Discontents* on, 296, 297  
 collective psychology and, 312  
 dualism and, 448  
 ethics and, 525–526  
 Freud's self-analysis and, 425  
*Future of an Illusion, The* on, 660–661  
 illusion and, 797  
 Indian psychoanalysis and, 808  
 jouissance and, 1104  
 Jung on, 660, 1399, 1467  
 Lacan and, 930  
 Marxism and, 1017  
*Moses and Monotheism* on, 1077–1078  
 mother goddess, 1079–1080  
 mysticism and, 1091  
 myth of origins and, 1092  
 numinous and, 1165  
 oceanic feeling and, 265, 296, 425, 660, 899, 1181–1182, 1511  
 projection and, 1337  
 Schreber case and, 1376  
 totemism and, 1768–1769  
*Weltanschauung* and, 1855  
*Religions of the Semites, The* (Smith), 1097, 1321  
 Religious belief, 1691  
 Religious reality, 1718  
 REM (paradoxical) sleep, 1614  
 “Remarks about the Formation of the Self” (Kohut), 605  
 “Remarks on the Theory and Practice of Dream-Interpretation” (Freud), 1475  
 Remembering, 10, **1467–1468**  
 “Remembering, Repeating and Working-Through” (Freud), 5, 10, **1469–1470**  
 on fundamental rule, 656–657  
 on infantile amnesia, 820  
 on lifting of amnesia, 977  
 on memories, 1041  
 on memory, 1043  
 on repetition, 1473  
 on resistance, 1488–1489  
 on screen memories, 1555  
 on silence, 1610  
 on termination of treatment, 76  
 on transference, 422  
 on transference neuroses, 1786  
 on working-through, 1879, 1880  
 Reminiscences, **1470–1471**  
*Reminiscences of a Viennese Psychoanalyst* (Sterba), 1659  
 Remus, José, 1051, 1052  
 Renaud, André, 246  
 Reparation, **1471–1472**  
 Repetition, **1472–1474**  
 acting out and, 10, 267  
 amnesia and, 65  
 children's play and, 283  
 constructions and, 338  
 cure and, 359  
*Development of Psycho-Analysis* on, 407  
 protective shield and, 1341  
 psychic temporality and, 1360  
 Real and, 1454  
 rivalry and, 1507  
 symbolic and, 1710  
 time and, 1757  
 transference and, 1469, 1777  
 traumatic neuroses and, 1804  
 Repetition compulsion, **1474–1476**  
 activity/passivity and, 17  
 death instinct and, 371, 1474–1475  
 dreams and, 437  
 dualism and, 449  
 ego and, 464  
 excitation and, 534  
 Fairbairn on, 546  
*Fort-da* game and, 599–600  
 identity and, 795  
 mnemonic traces and, 1064  
 negative transference and, 1127  
 punishment dreams and, 1422–1423  
 reality principle and, 1450  
 Schur on, 1549  
 suffering and, 1684  
 “Repetition in Analysis Worse than Original Trauma” (Ferenczi), 1726  
 Repetitive dreams, **1476**  
 “Reply to Criticisms of My Paper on Anxiety Neuroses, A” (Freud), 1136  
 Répond, A., Guex and, 714–715  
 Repond, André, 1700  
 “Report on a Method of Eliciting and Observing Certain Symbolic Hallucination-Phenomena” (Silberer), 1608  
*Repräsentant*. See Representation  
 Representability, 78, 437, 441, 442, **1476–1477**  
 Representation, **780–783**  
 act/action and, 9  
 action-presentations and, 12–13  
 aphasia and, 106  
 compulsion and, 322  
 condensation and, 324, 325  
 conscious processes and, 333  
 creativity and, 352  
 cultural transmission and, 358  
 day's residues and, 367  
 death and, 369, 370  
 deferred action and, 380  
 dreams and, 437, 438, 441, 442  
 experience of satisfaction and, 536  
 fantasy and, 551, 554, 782  
 functional phenomenon and, 654  
 hallucinatory and, 722  
 hysterical paralysis and, 774  
 ideational, 785–786, 841, 989  
 ideology and, 796  
*infans* stage and, 813  
 instinctual, 786, 841  
 object *a* and, 1173  
 pain and, 1220  
 pictogram, 221, 785, 813, 1285–1287, 1312–1313, 1841  
 primal and, 1311–1312  
 primary/secondary processes and, 1318–1319  
 prohibition and, 1331  
 quantitative/qualitative dimensions and, 1428  
 repression and, 1482–1483  
 symptoms and, 1715  
 unconscious fantasies and, 1817  
 visual and, 1840–1841  
 work of the negative and, 1129  
 working over and, 1877–1878  
 working-through and, 1880  
 Representation of affect, **1477–1478**  
 Repressed, derivatives of the, 1478–1479, **1481**, 1484, 1491  
 See also Return of the repressed  
 Repressed, the, **1478–1481**  
 return of, 321, 325, 1478, 1481, 1491–1492  
 See also Repression  
 Repressed memories, 1689  
 Repression, **1481–1485**  
 activity/passivity and, 17  
 adolescence and, 28  
 alcoholism and, 42  
 alpha-elements and, 50  
 amnesia and, 63, 64, 65

## INDEX

Volume 1, pp. 1–662; Volume 2, pp. 663–1344; Volume 3, pp. 1345–1892

- anti-Semitism, 291  
 anticathexes and, 94, 1309, 1478, 1482, 1492  
 antilibidinal ego and, 96  
 Aulagnier-Spairani on, 111  
 automatism and, 143  
 bisexuality and, 186  
 censorship and, 262–263  
 character and, 269  
 condemning judgments and, 900–901  
 conflict and, 325  
 consciousness and, 333  
 constructions and, 335  
 contradiction and, 341  
 dead mother complex and, 369  
 decathexis and, 374  
 defense mechanisms and, 377  
 defense neuroses and, 19  
 defenses and, 374, 375  
 deferred action and, 380  
 déjà vu and, 382  
 Deleuze/Guattari on, 98  
 depression and, 395  
 derivatives of the repressed and, 1478–1479, 1481, 1484, 1491  
 desexualization and, 398–399  
 doubt and, 435  
 dreams and, 436, 437  
 drives and, 446  
 dynamic point of view and, 451  
 ego and, 463, 464  
 erotogenic zones and, 518  
 feminist views of psychoanalysis and, 578  
 flight into illness and, 590  
 forgetting and, 596, 597  
 fundamental rule and, 656  
 German romanticism and, 673  
 history and, 750  
 hysteria and, 773  
 id and, 778  
 imago and, 800  
 incest and, 804  
 infantile amnesia and, 819  
 lifting of, 976, 977, **1486–1487**  
 memory and, 1043  
 myth of origins and, 1092–1093  
 negation and, 1122–1123  
 negative hallucination and, 1124  
 neurotic defenses and, 1141  
 organic, 1206–1208  
 paranoia and, 1229–1231  
 perception-consciousness system and, 1249  
 persecution and, 1252–1253  
 phobias and, 1273  
 primal, 1050, 1308–1309, 1308–1310, 1483, 1485  
 primary narcissism and, 1110  
 “Project for a Scientific Psychology, A” on, 1332  
 rivalry and, 1506  
 scotomization and, 1554  
 seduction theory and, 1592  
 sense of smell and, 1616  
 shame and, 1599  
 signifying chain and, 1607  
 splitting and, 1646, 1650  
 splitting of the object and, 1642  
 subject and, 1673  
 suppression and, 1693–1694  
 symbolic equation and, 1708  
 symptom-formation and, 1717  
 symptoms and, 1715  
 transgression and, 1792  
 translation and, 1797  
 word association and, 1872  
 work and, 1875  
 work of the negative and, 1129  
 working-through and, 1879  
*See also* Reaction-formations  
 “Repression” (Freud), **1485–1486**  
 action-presentations and, 12  
 on adaptation, 22  
 on defenses, 375  
 on derivatives of the repressed, 1481, 1484  
 on instinctual representative, 841  
 on neurotic defenses, 1142  
 on psychic representative, 1358  
 on quantitative/qualitative dimensions, 1428  
 on representation, 781  
 on repression, 1478–1479, 1483, 1484  
 on return of the repressed, 1492  
 on substitute formations, 1681  
*Reproduction of Mothering: Psychoanalysis and the Sociology of Gender* (Chodorow), 577  
 Repudiation, **1487**  
 Réquet, A., 450  
 Rescue fantasies, **1487–1488**  
 Research. *See* Psychoanalytic research  
 Research instinct. *See* Knowledge instinct  
 Resistance, **1488–1490**  
 acting out and, 10  
 censorship and, 262, 263  
 change and, 267, 268  
 character and, 269  
 character neurosis and, 273  
 child analysis and, 1733  
 death instinct and, 371  
*Development of Psycho-Analysis* on, 407  
 “Dora” case and, 1384  
 doubt and, 435  
 ego and, 464  
 ego psychology and, 487  
 “Elisabeth von R.” case and, 496, 1488  
 ethics and, 525  
 failure neurosis and, 544  
 fundamental rule and, 656–657  
 group psychotherapies and, 714  
 id and, 778–779  
 interpretation and, 862, 863  
 latent/manifest dream elements and, 1008  
 repression and, 1479  
 sadomasochism and, 1527  
 therapeutic alliance and, 1740  
 transference and, 1488, 1777  
 transgression and, 1792  
 working-through and, 1489, 1879, 1880  
*Résistance dans l’analyse, La* (Favez), 561  
 Resnik, Salomón, 118  
 Resolution of the transference, **1490–1491**  
 Resonance, 601  
*Restoration of the Self, The* (Kohut), 13, 185, 318, 691, 784, 1060, 1324, 1574, 1576  
 Retardation, mental, 1572  
 Return of the repressed, 321, 325, 1478, 1481, **1491–1492**  
*See also* Parapraxes; Repressed, derivatives of the  
 “Rêve, illusion et connaissance” (Diatkine), 411  
*Rêve-éveillé en Psychothérapie, Le* (Desoille), 400  
 Reverchon-Jouve, Blanche, 887, 898, 930, **1492–1493**, 1619, 1634  
 Reverdy, Pierre, 223  
 Reverie, **554–555**, **1493–1494**  
 attention and, 127–128  
 Bion on, 5, 52, 127–128, 184, 1030–1031, 1169, 1317  
 boredom and, 203  
 capacity for, 52, 127–128, 1030–1031, 1169, 1317, 1340  
 heroic self and, 739  
 infantile psychosis and, 826  
 negative capability and, 1124  
 projective identification and, 52  
 protective shield and, 1340

Volume 1, pp. 1–662; Volume 2, pp. 663–1344; Volume 3, pp. 1345–1892

- Reversal into the opposite, **1494–1495**  
 activity/passivity and, 17  
 death instinct and, 372  
 sleep and, 1614  
 turning around and, 1494, 1495, 1807–1808
- Reversed perspective, 184
- Rêves et leur Interprétation psychanalytique, Les* (Dreams and their psychoanalytic interpretation) (Allendy), 46
- Révész, Erzsébet, 765
- Révész, Géza, 737
- Révész, László, 766
- Rêveurs éveillés* (Borel), 205
- Review of Psychoanalytic Teaching. See Zeitschrift für psychoanalytische Pädagogik*
- Revista Brasileira de Psicanálise*, 919, 1012, 1015
- Revista de la Sociedad Colombiana de Psicoanálisis*, 315
- Revista de psicanálise de Porto Alegre*, 217
- Revista de psicanálisis*, 117, 248, 1447, **1496**
- Revista de psiquiatria y disciplinas conexas*, 1, 384, 1253, **1496–1497**, 1832
- Revista Latinoamericana de Psicoanálisis*, 567
- Revista psicanalítica*, 217
- Revista uruguaya de psicanálisis*, 150
- Révolte contre le père, La* (Mendel), 612
- Révolution surréaliste, La*, 1695
- Revue belge de psychanalyse*, 158
- Revue de Genève*, 1620
- Revue de médecine psychosomatique*, 277
- Revue de pédagogie psychanalytique* (Review of Psychoanalytic Pedagogy), 36
- Revue française de psychanalyse*, 608, **1497–1500**  
 Bonaparte and, 200, 934, 988, 1497, 1498, 1499  
 Claude and, 305, 1497–1498  
 French psychoanalysis and, 609  
 Hesnard and, 200, 742, 934, 1497, 1498  
 Kestemberg-Hassin and, 911  
 Laforgue and, 200, 934, 1497, 1498  
 Loewenstein and, 988, 1498  
 Odier and, 1182, 1497, 1498  
 Pichon and, 200, 1283, 1497, 1498  
*Psyché* and, 1350  
 recent role of, 613  
 Saussure, Raymond de and, 1536  
 Schlumberger and, 1541  
 Second World War and, 1557
- Société psychanalytique de Paris and, 1497, 1498, 1499, 1624, 1625, 1630  
 surrealism and, 1695  
 Swiss psychoanalysis and, 1700
- Revue Internationale de psychopathologie*, 569
- Rey, Henri, 1507
- Rey, Jean Carlos, 1828, 1829
- Rey, Jean-Michel, 692
- Rey de Castro, Álvaro, 1254
- Reyes, Baltazar, 1268
- Reynolds, P. Guy, 131
- Rhode-Dachser, Christa, 678
- Rhythmic behavior, 1573
- Ribas, D., 419
- Ribot, Théodule, 1672  
 on doubt, 435  
 Janet and, 885  
 Le Bon and, 953  
 on memory, 1042  
 on self-consciousness, 1569
- Ricciardi von Platen, Alice, 880
- Richard, Gustave, 449, 1556
- Richard, Hélène, 1247
- Richard, Henri, 245
- “Richard” case, 1276, **1500–1501**
- Richard Sterba: The Collected Papers*, 1659
- Richards, Angela, 681, 1137, 1199, 1654, 1669–1670
- Richards, Arnold, 897
- Richet, Charles, 768
- Richman, John, 601
- Richter, Horst-Eberhard, 677, 1602
- Rickert, Heinrich, 1547
- Rickman, John, **1501–1502**  
 Bion and, 183, 1502  
 British psychoanalysis and, 699, 1501  
 on group analysis, 709
- International Journal of Psychoanalysis, The* and, 593, 853
- Jones and, 893, 1655
- Khan and, 913
- Second World War and, 1558
- Tavistock Clinic and, 1728
- Ricoeur, Paul  
 Colloque sur l’ inconscient and, 315, 610
- Dalbiez and, 364  
 on epistemology, 1371  
 French psychoanalysis and, 611  
 on hermeneutics, 738
- Lacan and, 459  
 philosophy and, 1271
- Riddle of the Sphinx, The* (Róheim), 1510
- Rie, Oskar, 667, 916, 924, **1502–1503**
- Rieder, Ines, 1391
- Riemann, Fritz, 1131
- Riesenberg, Ruth, 284, 285
- Rigaud, A., 42
- “Righophobia, Die” (Perrotti), 1251
- Riklin, Franz, 180, 320, 443, 1260, 1534, 1702
- Rilke, Rainer Maria, 586, 674, 1195
- Rimbaud, Arthur, 1695
- “Ring of Polycrates, The” (Schiller), 1539
- Rioch, David, 1688
- Rioch, Janet, 1688, 1746
- Risk-taking, 1686
- Rites. *See* Rituals
- Rittmeister, John, 1557
- Rittmeister, John Friedrich Karl, 406, 676, 689, 910, **1505–1506**
- Rituals, **1503–1505**, 1504, 1724
- Ritvo, Samuel, 205
- Rivalry, **1506–1507**
- Rivers, William Halse, 696, 1501
- Rivière, Jacques, 1634
- Riviere-Hodgson Verrall, Joan, **1507–1508**  
 Australian psychoanalysis and, 130  
 British psychoanalysis and, 696, 697  
 Controversial Discussions and, 343, 697  
 on dependence, 392  
 on femininity, 577
- International Journal of Psychoanalysis, The* and, 229, 593, 1507
- Isaacs-Sutherland and, 873, 1507
- Jones and, 893, 1507, 1655  
 on negative therapeutic reaction, 1126
- Psychanalyse, La* and, 1348
- Standard Edition* and, 1655, 1663
- Winnicott and, 1507, 1861
- Zetzel-Rosenberg and, 1887
- Rivista di psicoanalisi*, 663, 878, 879, 881, **1508**, 1854
- Rizzo, Francis, 690
- Roazen, Paul, 642, 1608, 1727
- Robant, Claude, 807
- Robert, François, 124
- Robert, Marthe, 611, 871, 900
- Robertson, George, 696
- Robertson, James, **1508–1509**, 1728
- Robin, Gilbert, 204, 205, 305, 329
- Robinson, Shalom, 877
- Roboz, V., 131
- Roch, Michel, 703
- Roch-Meyerhof, Etienne, 1701
- Roche, Jean-François, 1572

## INDEX

Volume 1, pp. 1–662; Volume 2, pp. 663–1344; Volume 3, pp. 1345–1892

- Rocking, 1573  
 Rodker, John, 801  
 Rodrigué, Emilio, 117, 217  
 Rodriguez, Diego, 1052  
 Rogers, Carl, 759, 1445  
 Róheim, Géza, **1509–1510**  
 anthropology and, 93, 1000, 1509–1510  
 on dreams, 443  
 ethnopschoanalysis and, 527  
 Ferenczi and, 580, 1509  
 Hungarian psychoanalysis and, 765, 766, 1510  
 Hungarian School and, 764  
 Kovács-Prosznitz and, 923, 1509  
 lay analysis and, 1558  
 Lorand and, 991  
 Malinowski and, 1005, 1510  
 on myth of origins, 1321  
 on mythology, 443, 1094, 1099  
 on Oedipus complex, 1186  
 on otherness, 1774  
 on prehistory, 1303  
 sociology and, 1632  
 Rojas, Nerio, 116  
 Role-actualization, 1339  
 Rolla, Edgardo, 118  
 Rolland, Romain Edme Paul-Émile, **1510–1512**  
 “Disturbance of Memory on the Acropolis, A” and, 424–425, 638, 1182, 1511  
 on *Future of an Illusion, The*, 296, 660  
 German romanticism and, 674  
 on religion, 265, 296, 1091, 1181–1182, 1511  
 Schiff and, 1537  
 Zweig, Stefan and, 1890  
 Romanian psychoanalysis, **1512**  
 Romanian Psychoanalytic Society, 1512  
 Romanticism. *See* German romanticism  
 “Rome Report” (Lacan), 930  
 Romeo and Juliet, adolescence and, 27  
 Romm, May, 992, 1529  
 Rondepierre, André, 1083  
*Roots of Crime, The* (Glover), 684  
 Roper, Lindal, 1393  
 Rorschach, Hermann, 1394, 1398, **1512–1513**  
 Minkowska-Brokman and, 1056  
 Oberholzer and, 1167  
 Pfister and, 1260  
 photograph of, III:pl.7  
 Swiss psychoanalysis and, 1703  
 Rosanes, Ignaz, 1836  
 Rosen, John N., 414, 1404  
 Rosenberg, Benno  
 on dismantling, 420  
 on fusion/defusion, 658, 659  
 Kestemberg-Hassin and, 911–912  
 on life instinct, 975  
 on masochism, 1022, 1315–1316  
 on sadism, 1526  
 on turning around, 1807  
 Rosenfeld, David, 138, 896, 1806  
 Rosenfeld, Eva Marie, **1513–1514**  
 Blos and, 196  
 Hietzing Schule and, 236, 510, 745, 1513  
 Tegel clinic and, 1734  
 Rosenfeld, Herbert Alexander, **1514–1515**  
 on addiction, 23  
 on alcoholism, 42  
 Argentinian psychoanalysis and, 118  
 on envy, 508  
 on infantile psychosis, 824  
 Italian psychoanalysis and, 879  
 Los Angeles Psychoanalytic Society/Institute and, 992  
 on narcissism, 1106–1107, 1515  
 on paranoia, 1231  
 on paranoid-schizoid position, 1233  
 on projective identification, 1338  
 on psychotic transference, 1419  
 Riviere-Hodgson Verrall and, 1507  
 Rosenkötter, Lutz, 1351  
 Rosenthal, Tatiana, 674, **1515–1516**, 1518  
 Rosenzweig, Saul, 1395  
 Rosolato, Guy  
*Cahiers Confrontation, Les* and, 241  
 on cinema, 294  
 on displacement, 422  
 École freudienne de Paris and, 457, 458  
 on exhibitionism, 535  
 on experience of satisfaction, 536  
 French psychoanalysis and, 613  
*Inconscient, L’* and, 807  
 on intergenerational phenomena, 846  
 on nonverbal communication, 1154  
*Nouvelle Revue de psychanalyse* and, 1162  
 on perversion, 1259  
*Psychanalyse, La* and, 1348  
 on psychogenesis, 610  
 on repetition, 1474  
 surrealism and, 1696  
 Ross, Helen, 724, **1516–1517**  
 Ross, Nathaniel, 897, 898  
 Roth, Marcel, 1701  
 Rothfield, Rose, 131  
 Rotter, Lilian, 765, 766  
 Rouart, Julien, 539, 1152  
 Roublef, Irène, 458, 807  
 Rouchy, Jean-Claude, 1632  
 Roudinesco, Elisabeth, 327, 742  
 Rouget, Gilbert, 1774  
 Rousillon, René, 1226, 1412, 1674  
 Rousseau, Jean-Jacques, 354, 544, 1021, 1158, 1159  
 Rousseau-Dujardin, Jacqueline, 611  
 Roussillon, René, 1126, 1170, 1412, 1413  
 Roustang, François, 266  
 Collège des Psychanalystes and, 314, 1835  
*Confrontation* and, 327  
 on evenly-suspended attention, 531  
 Groddeck and, 706  
*Inconscient, L’* and, 807  
 Viderman and, 1835  
 Roux, Marie-Lise, 1466, 1499  
 Roux, Wilhelm, 1197  
 Roxo, Henrique, 214  
 Royal Hungarian Institute for Psychopathology and Psychotherapy, 1721  
*Royaume intermédiaire, Le* (Gressot), 703  
 Royce, Josiah, 1424  
 Rubinstein, Benjamin B., **1517–1518**  
 Ruddick, Bruce, 242, 243  
 Rudhart, Jean, 1095  
 Rudolfer, Noemy, 215  
 Ruhs, August, 135  
 Ruiz, Ma Teresa, 1637  
 Ruiz-Castillo, José, 175  
 Rule of abstinence. *See* Abstinence  
*Rules of Sociological Method* (Durkheim), 1631  
 Rumination, 844, 918  
 Russell, Bertrand, grid and, 704  
 Russian Psychoanalytic Association, 1519, 1544  
 Russian/Soviet psychoanalysis, **1518–1520**  
 analytic psychodrama and, 78  
 Chertok and, 277  
 Chinese psychoanalysis and, 286  
 Detski Dom and, 402–403, 1515  
 Ossipov and, 1212  
*Psychoterapia* and, 1411  
 Spielrein and, 1639  
 Wulff and, 1518, 1519, 1881  
 Rycroft, Charles Frederick, 937, **1520–1521**
- S**  
 Saba, Umberto, 1853

Volume 1, pp. 1–662; Volume 2, pp. 663–1344; Volume 3, pp. 1345–1892

- Sábato, Ernesto, 247
- Sacher-Masoch, Leopold von, 1020, 1024
- Sachs, Hanns, **1523–1524**
- Alexander, Franz Gabriel and, 42, 1523
- American Imago* and, 60, 801, 803
- Balint and, 148, 1523
- Balint-Szekely-Kovács and, 149
- Berliner Psychoanalytisches Institut and, 165, 166, 1523
- Bernfeld and, 169
- Boston Psychoanalytic Society/Institute and, 207
- British Psycho-Analytical Society and, 228
- cinema and, 293, 295
- Delgado and, 385
- Deutsche Psychoanalytische Gesellschaft and, 675
- Dutch psychoanalysis and, 1132–1133
- First World War and, 586
- Fromm and, 651, 1523
- Fromm-Reichmann and, 652
- Groddeck and, 706
- Happel and, 725
- H.D. and, 430
- Heimann and, 730
- Imago* and, 107, 800, 802, 1445
- International Psychoanalytical Association and, 854
- Loewenstein and, 988, 1523
- Low and, 997
- Meng and, 1044
- Müller-Braunschweig and, 1085
- Payne and, 1245
- photographs of, III:pl.8,9
- Psychotherapia* and, 1411
- Sarasin and, 1534
- Secret Committee and, 1561, 1562
- Secrets of a Soul, The* and, 1562, 1563
- on Shakespeare, 1597
- Sharpe and, 1599
- Société psychanalytique de Paris and, 1624
- training analysis and, 1769
- Van Ophuijsen and, 1200
- on visual arts, 1842
- Wiener psychoanalytische Vereinigung and, 1858
- Wilbur and, 1860
- Sachvorstellungen*. See Thing-presentations
- Sadger, Isidor Isaak, **1524–1525**
- on applied psychoanalysis, 107
- on homosexuality, 757, 1524–1525
- Hug-Hellmuth and, 761
- Vienna Ambulatorium and, 959
- Sadism, **1525–1526**
- activity/passivity and, 17, 1021
- aggression and, 33
- allergies and, 48
- ambivalence and, 56
- anal-sadistic stage and, 74, 1525
- anality and, 72
- anorexia nervosa and, 91
- archaic mother and, 112
- breastfeeding and, 221
- compulsion and, 322
- conflict and, 326
- cruelty and, 355
- death instinct and, 371, 1526
- dismantling and, 420
- fusion/defusion and, 659
- hatred and, 729
- jouissance and, 894
- libido and, 969
- masochism and, 1020, 1021, 1022, 1315, 1525–1526
- mastery and, 1024, 1025, 1526
- melancholia and, 1082
- need for punishment and, 1120
- object-choice and, 1174
- orality and, 1202
- phobias and, 1274–1275
- self-punishment and, 1577
- skin and, 1612, 1613
- turning around and, 1806–1807, 1808
- urethral eroticism and, 517
- See also Anal-sadistic stage; Oral-sadistic stage; Sadomasochism
- Sadomasochism, **1526–1527**
- anal-sadistic stage and, 73
- demand and, 388
- dipsomania and, 413
- pain and, 1281
- subject of the unconscious and, 1675
- See also Masochism; Sadism
- Safouan, Moustapha, 327, 1348, 1542
- Saint-Jean, André, 864
- Saint-Louis Augustin, Mrs. Raymond, 1014
- Saint-Simon, Henri de, 1631
- Sainte-anne Hospital, **1527–1528**
- Bonaparte and, 200
- Borel and, 204
- Claude and, 304–305
- Congrès des psychanalystes de langue française des pays romans and, 329
- Delay and, 382
- Évolution psychiatrique, L'* and, 1283
- Ey and, 539
- Inconscient, L'* and, 807
- Lacan and, 929, 930, 1583
- narco-analysis and, 1117
- Psychanalyse et les névroses, La* and, 1346
- Schiff and, 1537
- Schlumberger and, 1541
- Sokolnicka-Kutner and, 1634
- Sakellaropoulos, Pangiotis, 700
- Salles, M., 1052
- Salpêtrière Hospital, La, **1528–1529**
- Bernheim on, 170
- Charcot and, 275, 1528–1529
- Claude and, 304
- hysteria and, 772
- Smirnoff and, 1617
- Sameroff, A. J., 454
- Samiksa, the Journal of the Indian Psychoanalytical Society*, 808
- Sampson, Harold, 1532
- Samson, Father Henri, 246
- San Francisco Institute and Society for Psychoanalysis and Psychotherapy, 1531
- San Francisco Psychoanalytic Foundation, 1532
- San Francisco Psychoanalytic Society, 1612
- San Francisco Psychoanalytic Society and Institute, **1529–1532**
- San Francisco Psychotherapy Research Group, **1532–1533**
- Sandler, Anne-Marie, 132, 230, 877, 1533, 1732
- Sandler, Joseph, **1533–1534**
- British Psycho-Analytical Society and, 230
- child analysis and, 697, 1732
- on Counter-transference, 1368
- on evenly-suspended attention, 531
- Freud Professorship and, 230
- history of psychoanalysis and, 613
- on identification, 790
- International Journal of Psychoanalysis, The* and, 853, 1533
- International Psychoanalytical Association and, 857, 859
- Israeli psychoanalysis and, 877
- Japanese psychoanalysis and, 888
- object relations theory and, 1176, 1533
- on primary identification, 1314
- on projective identification, 1339
- Tavistock Clinic and, 1728
- therapeutic alliance and, 1741
- Sandman, The* (Hoffmann), 1393
- Sandplay, 14

## INDEX

Volume 1, pp. 1–662; Volume 2, pp. 663–1344; Volume 3, pp. 1345–1892

- Sane Society, The* (Fromm), 651  
 Santerre, Laurent, 864  
 Santiago, Virgilio, 1268  
 Santiago Wagner, José Maria, 215  
 Sarasin, Philipp, 1442, **1534**, 1549–1550, 1620, 1700, 1703  
 Sarró, Ramon, 1637  
 Sartiaux, Felix, 1080  
 Sartre, Jean-Paul, **1534–1535**  
 action-language and, 12  
 on determinism, 401  
 French psychoanalysis and, 613  
*Freud, The Secret Passion* and, 611, 644, 1365  
 “Homme au magnétophone, L” and, 612  
 Lagache and, 935  
 on phenomenology, 1266, 1267  
 philosophy and, 1271  
 Politzer and, 1294  
 on psychic apparatus, 1352  
 Sassoon, Siegfried, 696  
 Satgé, P., 1304  
 Satisfaction, experience of, **535–537**, 1713  
 Saucier, Jean-Louis, 1622  
 Sauget, Henri, 274, 1625  
 Saugy, Daisy de, 1701  
 Saussure, Ariane de, 305, 329, 608  
 Saussure, Ferdinand de  
 Lacan and, 982  
 on linguistics, 981–983  
 literature and, 986  
 on Name-of-the-Father, 1104  
 on Other, 1213  
 Pichon and, 1283  
 on signifier/signified, 1606–1607  
 on signifiers, 1604, 1605, 1761, 1814  
 structural theories and, 1666  
 structuralism and, 1668  
 on symbolism, 1708  
 on thing-presentations, 1742  
 Saussure, Janice de, 1701  
 Saussure, Raymond de, **1535–1536**  
*Archives de psychologie, Les* and, 302  
 Chertok and, 277  
 Clark-Williams and, 303  
 Claude and, 305  
 Congrès des psychanalystes de langue française des pays romans and, 329, 330, 608  
 European Psychoanalytical Federation and, 529, 1536  
 Flournoy, Henri and, 591  
 Flournoy, Théodore and, 592  
 Gressot and, 703  
 Kestenberg-Hassin and, 911  
 Nodet and, 1152  
 Portuguese psychoanalysis and, 1296, 1297  
*Psychoanalytic Study of the Child, The* and, 1381  
 Rambert and, 1442  
 representation and, 782  
 Sechehayé and, 1556  
 Société psychanalytique de Paris and, 608, 1497, 1536  
 Swiss psychoanalysis and, 1536, 1620, 1700, 1703  
 Tegel clinic and, 1734  
 Sauvagnat, François, 353  
 Savard, Rémi, 864  
 SBPA (Société Belge de Psychologie Analytique), 158  
*Scandinavian Psychoanalytic Review*, 391, 1157  
 Scarfone, Dominique, 245  
 Schachtel, Ernest, 759  
 Schaeffer, Jacqueline  
 on femininity, 574, 575  
 feminist views of psychoanalysis and, 578  
*Revue française de psychanalyse* and, 1500  
 Société psychanalytique de Paris and, 1629, 1630  
 Schafer, Roy  
 on act/action, 9  
 on action-language, 11–12  
 on action-presentations, 13  
 on change, 268  
 on failure neurosis, 544  
 on interpretation, 863  
 Rapaport and, 1446  
 on self-hatred, 1571  
 Schalin, Lars-Johan, 584  
 Schalit, Ilja, 876, 1734  
 Schapiro, Meyer, 1842  
 Scharff, David E., 1851  
 Scharff, Jill Savage, 1851  
*Schaulust*, 1553  
 Schegel, August Wilhelm von, 673  
 Scheler, Max, 1047, 1266  
 Schelling, Friedrich, 524, 1560  
*Schéma corporel, La* (Schilder), 1538  
 Schema L, 1031  
 Scherner, Karl, 673  
 Scheunert, Gerhard, 406, 676  
 Schib, Karl, 82  
*Schicksalanalyse* (Szondi), 1721–1722  
*Schicksalanalytische Therapie* (Szondi), 1722  
 Schiff, Paul, **1537**  
 Cárcamo and, 117, 247  
 Claude and, 305  
 Congrès des psychanalystes de langue française des pays romans and, 330  
 French psychoanalysis and, 608  
 Nazi Germany and, 1558, 1625  
 Sokolnicka-Kutner and, 1634  
 Schilder, Paul Ferdinand, **1537–1539**  
 on alcoholism, 41  
 on depersonalization, 393  
 on ego feeling, 478  
 on ego states, 488  
 former Yugoslavian psychoanalysis and, 1884  
 Foulkes and, 601  
 Freud, Anna and, 619  
 Hartmann and, 727  
 Isakower and, 874  
 on self-image, 1571  
 Vienna Ambulatorium and, 959  
 Wagner-Jauregg and, 1846  
 Schiller, Johann Christoph Friedrich von, 444, 479, 686, **1539–1540**, 1683  
 Schindler, Raoul, 134, 852  
 Schindler, Walter, 1131  
 Schizo-analysis, 98  
 Schizoid-paranoid position. *See* Paranoid-schizoid position  
 Schizoid personality, 1582  
 Schizoid position, 96–97  
*See also* Paranoid-schizoid position  
 “Schizonoïa, La” (Laforgue), 933  
*Schizophrènes, Les* (Racamier), 1435  
 Schizophrenia, **1540–1541**  
 Abraham, Karl on, 6, 1540  
 ambivalence and, 56, 57  
 anti-psychiatry on, 699  
 autism and, 136  
 autohistorization and, 142  
 Bak on, 146–147  
 Bleuler on, 195, 1234, 1540  
 Deleuze/Guattari on, 98–99  
 delusions and, 386  
 dementia and, 389  
 direct analysis and, 414  
 disintegration anxieties and, 418  
 double bind and, 433  
 Federn, Paul on, 487, 568, 1540  
 infantile, 823, 827–828  
 Jung on, 1396, 1398–1399, 1540

Volume 1, pp. 1–662; Volume 2, pp. 663–1344; Volume 3, pp. 1345–1892

- Khan on, 913  
 Meyer on, 1053, 1540  
 paranoid-schizoid position and, 1233  
 paraphrenia and, 1234  
 passage to the act and, 18  
 psychoses and, 1403  
 Rosenfeld, Herbert on, 1514–1515  
 scotomization and, 1553–1554  
 Searles on, 309–310  
 secondary narcissism and, 1110  
 self-mutilation and, 1572  
 self-representation and, 1578  
 social feeling and, 1618  
 splitting and, 389, 1647  
 stages and, 1652  
 symbolic realization and, 1556, 1709–1710  
 symptom-formation and, 1717  
 systems and, 1720  
 transference and, 310  
 word-presentations and, 1874  
 Schjelderup, Harald, 1156, 1157, 1260, 1698  
 Schjelderup, Kristin, 1260  
 Schkolnik, Fanny, 1829  
 “Schlagenphantasie und Tagtraum” (Anna Freud), 83  
 Schleiermacher, Friedrich, 181, 673  
 Schlemihl de Chamisso, Peter, 1597  
 Schlick, Moritz, 169, 1070  
 Schloss Tegel. *See* Tegel clinic  
 Schlumberger, Marc, **1541–1542**  
 Centre psychopédagogique Claude-Bernard and, 265  
 Chertok and, 277  
 Delay and, 383  
 Favreau and, 561  
 Granoff and, 692  
 Kestemberg-Hassin and, 911  
 Marty and, 1016, 1542  
 Racamier and, 1435  
 Schmideberg, Walter, 166, 284, 430  
 Schmideberg-Klein, Melitta, 284, 343, **1542–1543**, 1738  
 Schmidt, Gérard, 508  
 Schmidt, Otto, 402, 1518, 1519, 1543  
 Schmidt, Vera Federovna, 402, 1461, 1518, **1543–1544**, 1544  
 Schmidt, Vladimir (“Volik”), 1544  
 Schmiergeld, Adolf, 304  
 Schneider, Ernst, 302, 1260, **1544–1545**, 1702, 1886  
 Schneider, Michel, 1163, 1628  
 Schneider, Monique, 195, 574, 1271  
 Schneider, Pierre-Bernard, 1701  
 Schnitzler, Arthur, 732, 1132  
 Schoen, Alberto, 881  
*Scholastique freudienne, La* (Debray-Ritzen), 612  
 Scholz-Strasser, Inge, 136  
 School of the Freudian Cause. *See* École de la Cause freudienne  
 School phobias, 1275  
 Schopenhauer, Arthur, 313, 497, 811, 905, 1271, 1485  
*See also* Kantianism  
 Schotte, Jacques, 158, 1348  
 Schottlaender, Felix, 677, 1061, 1351  
 Schreber, Daniel Paul, 141, **1545–1547**  
*See also* Schreber case  
 Schreber case, **1375–1377**, 1545–1546  
 choice of neurosis and, 288  
 collective psychology and, 311  
 decathexis and, 374  
 dementia and, 389  
 depersonalization and, 393  
 drives and, 445–446  
 dualism and, 1070  
 ego and, 462  
 ego-instincts and, 483  
 fixation and, 588  
 foreclosure and, 595–596  
 friendship and, 647  
 homosexuality and, 757, 1227, 1229, 1230, 1232, 1377, 1545, 1546, 1587  
 hypochondria and, 770–771  
 identification and, 790  
 inferiority feelings and, 831  
 Katan on, 907  
 masochism and, 1021  
 megalomania and, 1036  
 narcissism and, 1105, 1113  
 paranoia and, 1227, 1229, 1230, 1545  
 paranoid psychosis and, 1232  
 paraphrenia and, 1234  
 persecution and, 1252  
 pregnancy fantasy and, 1302  
 projection and, 1335  
 psychic causality and, 1354  
 psychoses and, 1404  
 psychosis/neurosis distinction and, 1415  
 rationalization and, 1448  
 Real and, 1453  
 stages and, 1652  
 symptom-formation and, 1717  
 totemism and, 1768  
 Schreck. *See* Fright  
 Schülein, Johannes, 136  
 Schulman, Martin, 1380  
 Schulte, R. W., 677  
 Schultz, Johannes H., 678, 1465  
 Schultz-Hencke, Harald Julius Alfred Carl-Ludwig, 677, **1547–1548**, 1644  
 Berliner Psychoanalytische Poliklinik and, 164  
 German psychoanalysis and, 676, 678, 679  
 Göring Institute and, 406, 676, 1547  
 Kemper, Werner Walther and, 910  
 Müller-Braunschweig and, 1085  
 Nazi Germany and, 406, 676, 852, 1547  
 neopsychoanalysis and, 676, 679, 1130–1131, 1547, 1644  
*Psyche* and, 1351  
 Swedish psychoanalysis and, 1698  
 Schulze-Boysen, Harro, 1506  
 Schur, Helen, 233  
 Schur, Max, 296, 641, **1548–1549**  
 Brunswick and, 232, 233, 1548  
 on coprophilia, 346  
 Freud biography by, 627–628, 642  
*Journal of the American Psychoanalytic Association* and, 897  
 on primary anxiety, 90  
 Wiener psychoanalytische Vereinigung and, 1548, 1858  
 Schüssler, G., 135  
 Schuster, Peter, 133, 1858  
 Schwaber, Paul, 898  
 Schwartz, Murray, 1597  
 Schweizerische Ärztgesellschaft für Psychoanalyse, **1549–1550**  
 Schwenger, Ernst, 777  
 Schwidder, Werner, 677, 678, 852, 1131  
*Science and Method* (Poincaré), 1566  
 Science de l’homme, 611  
*Scientia*, 300  
 Scientific nature of psychoanalysis, **1550–1552**  
 American Academy of Psychoanalysis and, 59  
 Bachelard on, 145  
 Bernfeld on, 169  
 Binswanger on, 181  
 Brücke and, 230–231  
 catastrophe theory, 256  
 child analysis and, 1731  
 definition of psychoanalysis and, 1364  
 determinism and, 401  
 epistemology and, 1370  
 Freud, Anna on, 472  
 grid and, 704



## INDEX

Volume 1, pp. 1–662; Volume 2, pp. 663–1344; Volume 3, pp. 1345–1892

- hard scientific nature of psychoanalysis, 726–727
- Judaism and, 899
- multidisciplinary interactions, 108–109, 300–301, 309
- philosophy and, 1270, 1271
- remembering and, 1468
- research and, 1378
- selected facts and, 1566–1567
- Scilicet*, 611, **1552–1553**
- Scolni, Flora, 117
- Scope of Child Analysis, The* (Smirnoff), 1617
- Scopophilia, 541, 829, 1025, **1553**, 1843
- Scoptophobia. *See* Scopophilia
- Scoptophobia, 433
- Scotomization, 416, 933, 1284, **1553–1554**
- Scott, W. Clifford M., 243, 245, 853
- Screen dreams, 1614
- Screen-identifications, 791
- Screen memories, 26, 702, 1040, 1042, 1467, **1555–1556**
- “Screen Memories” (Freud), 169, 551, 594, 632, 1555, 1609
- Scritti* (Gaddini), 663
- SE. *See* Superego
- Searle, Nina, 685, 696, 697
- Searles, Harold F., 309–310
- Bigras and, 178
- Development of Psycho-Analysis* and, 407
- Ferenczi and, 328
- on ideational representation, 786
- on negative therapeutic reaction, 1126
- Nouvelle Revue de psychanalyse* and, 1163
- on schizophrenia, 1540
- Šebek, M., 361
- Sechehayé, Marguerite A., 1404, **1556–1557**, 1700, 1709–1710
- Second individuation process, 197
- Second Manifesto of Surrealism* (Breton), 1695
- Second topography. *See* Structural theory
- Second World War, **1557–1558**
- abandonment and, 2
- Boston Psychoanalytic Society/Institute and, 208
- cinema and, 292
- Congrès des psychanalystes de langue française des pays romans and, 330
- French psychoanalysis and, 608
- Imago Publishing Company and, 802
- Main and, 1003
- New York Psychoanalytic Institute/Society and, 1147–1148
- Société psychanalytique de Paris and, 1625
- Storfer and, 1659, 1662
- Swiss psychoanalysis and, 1701
- Tavistock Clinic and, 1728
- Winnicott and, 1861
- Secondary gain, 590, **664**, 1385, 1635, 1740
- Secondary narcissism, **1110–1111**
- Secondary revision, 437, 438, 441–442, **1558–1560**
- anticipatory ideas and, 95
- evenly-suspended attention and, 530–531
- jokes and, 890
- manifest dream elements and, 1007, 1559
- Secret Beyond the Door* (film), 293
- Secret Committee, The, **1561–1562**
- Abraham and, 5, 1561
- Eitingon and, 493, 1561
- Freud-Jung split and, 640, 854, 1193, 1561
- International Psychoanalytical Association and, 854, 1561, 1562
- photograph of, III:pl.9
- psychoanalytic filiations and, 1373
- Rank and, 1445, 1561, 1562
- Secret of the Totem, The* (Lang), 1320
- Secrets, 6, 358, **1560–1561**
- Secrets of a Soul, The* (film), 293, 294, 295, 1365, 1523, **1562–1563**
- Sédat, Jacques, 314, 957, 1251, 1835
- Seduction, **1563–1565**
- activity/passivity and, 16–17
- anaclysis and, 69
- breastfeeding and, 221
- deferred action and, 378
- general theory of, 669–670, 1197, 1204, 1342, 1566
- introjection and, 870
- scenes of, 1061–1062, 1563, 1565–1566
- Seduction scenes, 1061–1062, 1563, **1565–1566**
- Seduction theory, 669–670, 735, 1183–1184, 1563, 1754–1755
- amnesia and, 65
- childhood and, 280
- choice of neurosis and, 287–288
- conversion and, 345
- developmental processes and, 1329
- Eissler on, 490–491
- family and, 547
- homosexuality and, 757
- memories and, 1040
- mnemonic symbols and, 1061–1062
- mnemonic traces and, 1063, 1064
- neuroses and, 669–670, 735, 1142–1143
- psychic reality and, 1357
- puberty and, 1420, 1592
- real trauma and, 1455
- stages and, 1652
- trauma and, 1801
- Seele und Leben* (Schilder), 1538
- Seelensucher, Der: ein psychoanalytische roman* (Groddeck), 706
- Segal, Hanna
- Argentinian psychoanalysis and, 118
- child analysis and, 1732, 1733
- on infantile psychosis, 825
- Italian psychoanalysis and, 879, 880
- Journal de la psychanalyse de l'enfant* and, 896
- on lack of differentiation, 933
- on melancholia, 1039
- Money-Kyrle and, 1070
- on neuroses, 1139
- on paranoid-schizoid position, 1233
- on phobias, 1276
- Polish psychoanalysis and, 1292
- on psychotic transference, 1419
- on reparation, 1472
- Riviere-Hodgson Verrall and, 1507
- on symbolic equation, 1708–1709
- on symbolization, 1713
- on “vagina dentata” fantasy, 1831
- on visual arts, 1842
- Segal, Perry, 244
- Segalla, Rosemary, 1851
- Segantini, Giovanni, 1841
- Seglas, Jules, 143
- Seguin, Carlos Alberto, 1253
- Seif, Leonhard, 689, 1011
- Seitter, Walter, 135
- Seitz, Philip, 1331
- Selbst*. *See* Self
- “Selbst, Das” (Róheim), 1510
- Selbstanalyse*. *See* Self-analysis
- Selected facts, 953, 1123–1124, **1566–1567**, 1750
- “Selected Problems of Self Psychological Theory” (Kohut), 1574, 1787–1788
- Self, **1567–1568**, **1579–1580**
- disintegration products and, 419
- ego and, 467, 477
- identity and, 1324
- Klein on, 467
- narcissistic transference and, 1115
- pictogram and, 1286
- primary identification and, 1314
- true/false, **1581–1583**

Volume 1, pp. 1–662; Volume 2, pp. 663–1344; Volume 3, pp. 1345–1892

- See also* False self
- Self (analytical psychology), **1580–1581**  
 as archetype, 115, 1581  
 compensation and, 317  
 ego and, 469–470  
 individuation and, 812  
 unconscious and, 1400
- Self-analysis, 985, **1568**, 1769  
*See also* Freud's self-analysis
- Self-analysis* (Horney), 759
- Self and the Object World, The* (Jacobson), 883
- Self-consciousness, 50, **1569–1570**
- Self-esteem, 1038, 1227, **1570**, 1687
- Self-hatred, 41, 1126, **1570–1571**, 1588
- Self-identification, 52
- Self-image, 238, **1571–1572**
- Self-mutilation, **1572–1574**, 1687
- Self-object, **1574–1575**, 1595  
*amae* and, 56  
 compensatory structures and, 317  
 disintegration products, 419  
 ego boundaries and, 474  
 sexualization and, 1595
- Self-preservation, **1575–1576**  
 aggression and, 34  
 anaclisis and, 68–69, 521  
 conflict and, 326  
 drives and, 446  
 ego functions and, 478  
 ego-instincts and, 482  
 erotogenic zones and, 518, 520, 521  
 hatred and, 729  
 life instinct and, 975  
 masochism and, 1022  
 narcissism and, 1105, 1674  
 primary need and, 1316  
 suicide and, 1688  
 tenderness and, 1736
- “Self-Preservation and the Death Instinct” (Simmel), 1612
- Self psychology, **1576–1577**  
 action-thought and, 14  
 analytical psychology and, 1581  
 Bettelheim on, 173, 503  
 bipolar self and, 185  
 ego and, 467, 477  
 Fairbairn and, 546  
 fragmentation and, 605  
 identity and, 795  
 Los Angeles Psychoanalytic Society/Institute and, 993
- narcissistic injury and, 1113
- self-image and, 1572
- true/false self and, 1582
- Self-punishment, 37, 38, **1577–1578**  
*See also* Punishment, need for
- Self-representation, 883, **1578–1579**
- Self-sabotage, 27
- Self-soothing behaviors, 420, 1341
- Self-state dreams, **1579**
- Selfobject. *See* Self-object
- Selye, Hans, 125
- “Séméologie des obsessions et idées fixes” (Pitres and Régis), 1459
- Séminaires psychanalytiques de Paris, 612
- “Seminar on the Purloined Letter” (Lacan), 328
- Seminars (Lacan), 192, **1583–1584**  
*See also specific seminars*
- Semiology, 1716
- Semiology. *See* Psychoanalytic semiology
- Semiophysics: a sketch* (Thom), 256
- Semiotics, 295–296
- Sens de la psychanalyse, Le* (Pasche), 1242
- Sense and Non-Sense of Revolt, The* (Kristeva), 1303
- Sense/nonsense, **1584–1586**
- Separation  
 abandonment and, 3  
 asthma and, 124  
 Bowlby on, 212  
 love and, 994–995  
 Mahler-Schönberger on, 1002  
 vs. mourning, 3  
 object *a* and, 1173  
 paranoia and, 1228  
*See also* Individuation
- Separation anxiety, 102, 105–106, 1664–1665, 1682
- Serbian psychoanalysis, 1884–1885
- Serbski, Vladimir P., 1411, 1518
- Sergent, Émile, 744
- Serlin, Carlo, 864
- Servadio, Emilio, **1586–1587**  
 Congrès des psychanalystes de langue française des pays romans and, 330  
 Gaddini and, 663  
 Indian psychoanalysis and, 807  
 Italian psychoanalysis and, 878, 879, 881  
*Psyché* and, 1350  
*Rivista di psicoanalisi* and, 1508  
 Tomasi and, 1758  
 Weiss and, 1854  
 Sesser, Miguel, 1828
- Setting, 606
- Seulin, Christian, 1476
- Seven* (film), 292
- Seven-Percent Solution, The* (film), 293
- Seven Sermons to the Dead* (Jung), 811
- “Seventeenth-Century Demonological Neurosis, A” (Freud), **1587**, 1774
- Seventh Heaven* (film), 293, 294
- Severn, Elizabeth, 328, 1465
- Sex and Character* (Weininger), **1587–1588**, 1852, 1853
- Sex and Gender* (Stoller), 1660
- Sex and Repression in Savage Society* (Malinowski), 1005
- Sex and the Single Girl* (film), 293
- Sex reassignment, 1799
- Sexual abuse. *See* Seduction; Seduction theory
- Sexual difference recognition, **1588–1589**, 1594  
*See also* Castration anxiety; Oedipus complex; Penis envy
- Sexual drives, **1589–1590**, 1752  
 anaclisis and, 68–69  
 biological bedrock and, 182  
 conflict and, 326  
 ego-instincts and, 445, 482, 483  
 erotogenic zones and, 518  
 groups and, 712  
 imaginary and, 799  
 life instinct and, 975, 1589  
 overview of, 444–445  
 self-preservation and, 1575  
 subject and, 1674  
 subject of the drive and, 1674  
 “Sexual Enlightenment Of Children, The” (Freud), **1590**
- Sexual etiology theory, 1670
- Sexual excitement, 1660
- Sexual Excitement* (Stoller), 1660
- Sexual instincts. *See* Sexual drives
- Sexual inversion, 1685
- Sexual Life (Physiology and Pathology)* (Moniz), 1296
- Sexual Life of Savages in Northwestern Melanesia, The* (Malinowski), 1005
- Sexual Politics* (Millet), 576
- Sexual Revolution, The, toward a Self-Governing Character Structure* (Reich), 1018
- Sexual States of Mind* (Meltzer), 419
- Sexual Struggle of the Young, The* (Reich), 1461
- Sexual theories of children, **1590–1592**

## INDEX

Volume 1, pp. 1–662; Volume 2, pp. 663–1344; Volume 3, pp. 1345–1892

- genital stage and, 672  
 Oedipus complex and, 1185  
 truth and, 1805  
 “vagina dentata” fantasy and, 1831  
 visual and, 1841  
 Sexual traumas, **1592–1593**  
   *See also* Seduction theory; Trauma  
*Sexualité d’aujourd’hui, La* (Berge), 162  
 Sexuality, **1593–1595**  
   actual vs. defense neuroses and, 19, 20  
   adolescence and, 26  
   aggression and, 33  
   alcoholism and, 41  
   animal magnetism and, 85  
   anorexia nervosa and, 91  
   anxiety and, 99  
   aphanisis, 105–106  
   basic assumptions and, 151  
   belief and, 159  
   boundary violations and, 209, 210  
   cultural changes in, 60–61  
   defenses and, 374  
   deferred action and, 379–381  
   Eros and, 512–513  
   intellectualization and, 844  
   literature and, 987  
   Merleau-Ponty on, 1047  
   nightmares and, 1149  
   “On the Sexual Theories of Children” on, 1194–1195  
   “Project for a Scientific Psychology, A” on, 1333–1334  
   specific actions and, 1638  
   *See also* Drives; Libidinal development; Sexual drives  
 “Sexuality in the Aetiology of the Neuroses” (Freud), 19, 41, 412, 525, 653, 1353  
 Sexualization, 398, **1595**  
 Sexuation, 1031, 1588–1589, **1595–1596**  
 Shadow, 812, **1596–1597**  
 Shakespeare, William, 107, **1597–1598**, 1600, 1739  
 Shamanism, 921  
 Shame, 1067, **1598–1599**, 1680  
 Shapiro, Kenneth, 1396  
 Shapiro, Theodore, 897  
 Sharpe, Ella Freeman, **1599–1600**  
   British psychoanalysis and, 697  
   Controversial Discussions and, 343, 344, 697  
   Glover, Edward and, 684  
   Glover, James and, 685, 696  
   *Hamlet and Oedipus* and, 723  
   Khan and, 913  
   Rycroft and, 1520  
   on silence, 1610  
   Sheehan-Dare, Helen, 284  
   *Shell and the Kernel, The* (Abraham and Torok), 7, 1265–1266, 1765  
   Shell shock. *See* War neuroses  
   Shengold, Leonard, 515  
   Shentoub, Salem A.  
     on alcoholism, 42  
   Lebovici and, 954  
   Nacht and, 1102  
   on self-mutilation, 1572  
   Société psychanalytique de Paris and, 1626  
   Sheppard-Pratt Hospital (Maryland), 1688  
   Sherman, Murray, 1380  
   Sherozia, A. E., 277  
   Shields, Clarence, 237  
   Shlossberg, Teodoro, 117  
   Shoah. *See* Holocaust  
   *Shock Corridor* (film), 292  
   Shope, Robert, 1517  
   “Short Account of Psycho-Analysis, A” (Freud), 385, 415, 674, 1503–1504  
   “Short Study of the Development of the Ego, Based on an Analysis of Mental Problems, A” (Abraham), 516  
   “Short Study of the Development of the Libido, Viewed in the Light of Mental Disorders, A” (Abraham), 5–6, 270, 288, 869, 1106  
   Sibony, Daniel, 1156  
   “Sich Anklammern und Auf-SuchGehen” (Hermann), 307  
   Sidhoum, Mohand A. Ait, 1155  
   Sidis, Boris, 1822  
   Sif, Smiljka, 1155  
   *Sigmund Freud: His Family and Colleagues, 1928–1947* (film), 1603  
   *Sigmund Freud: His Life in Pictures and Words* (Freud and Grubrich-Simitis), 623  
   *Sigmund Freud: His Life in Pictures and Words* (Grubrich-Simitis), 1601  
   *Sigmund Freud: His Personality, His Teaching, His School* (Wittels), 1869  
   *Sigmund Freud: Life and Work* (Jones), 611, 642, 643, 644, 651, 893, 973–974, **973–974**  
   *Sigmund Freud: Man and Father* (Freud), 626  
   Sigmund Freud Archives, 490, 491, 642, **1600–1601**  
   *Sigmund Freud as Consultant* (Weiss), 1854  
   Sigmund Freud Copyrights Limited, **1601–1602**  
   Sigmund Freud Gesellschaft. *See* Sigmund Freud Society  
   Sigmund Freud Institute (Frankfurt), 677, 1061, **1602–1603**  
   Sigmund Freud Museum (Berggasse 19, Vienna), III:pl.10, 136, 163, 958, **1603**, 1859  
   Sigmund Freud Society, 133, 136, 163, 1859  
   *Sigmund Freud’s Mission* (Fromm), 651  
   Signal anxiety, 99, **1604**  
     Arlow on, 119  
     castration complex and, 251  
     guilt and, 718  
     helplessness and, 734  
     protective shield and, 1341  
     quota of affect and, 1433  
     specific actions and, 1639  
     suppression and, 1694  
   *Significance of Psychoanalysis for the Mental Sciences, The* (Sachs), 1523  
   “Significance of Sequences of Vowels, The” (Freud), 1723  
   Signifier/signified, **1606–1607**  
     displacement and, 422  
     fantasy and, 554  
     foreclosure and, 595  
     letter and, 961–962  
     sense/nonsense and, 1584  
     slips of the tongue and, 1615–1616  
     thing-presentations and, 1742  
   Signifiers, **1604–1606**  
     cinema and, 294  
     formula of, 1031  
     music and, 1089  
     nightmares and, 1150  
     parade of, 1225  
     phallus as, 1264–1265  
     philosophy and, 1270  
     phobias and, 1275, 1276  
     psychic causality and, 1354  
     splitting of the subject and, 1649  
     subject and, 1673  
     subject of the drive and, 1674  
     subject’s castration and, 1676  
     substitution of, 1047, 1048  
     symptoms and, 1718  
     topology and, 1761  
     unary trait and, 1814  
     *See also* Signifier/signified  
   Signifying chain, 1354, **1607**  
   Signs, 864, 1380  
   Siksou, Joyceline, 1304  
   Silberberg, M. D., 131

Volume 1, pp. 1–662; Volume 2, pp. 663–1344; Volume 3, pp. 1345–1892

- Silberer, Herbert, **1608–1609**  
 on alchemy, 40  
 on analogical interpretation, 71  
 on functional phenomenon, 654–655  
 on representability, 1477
- Silberstein, Eduard, 565, **1609–1610**, 1836, 1838
- Silence, 119, **1610–1611**
- Silence, The* (film), 294
- Silence of the Lambs, The* (film), 292
- “Silence of the Mother, The, or: Twenty Years Later” (Lombard), 1611
- Silent zones, 41
- Silveira, Nise da, 217
- Silverberg, William, 1745
- Simatos, Christian, 458, 1084
- Simbiosis y ambigüedad* (Bleger), 194
- Simenauer, Erich, 229
- Simmel, Ernst, **1611–1612**  
 Abraham, Karl and, 5, 6, 1611  
 on anti-Semitism, 291  
 Berliner Psychoanalytische Poliklinik and, 164, 493, 675  
 Berliner Psychoanalytisches Institut and, 165, 166, 1611  
 Bernfeld and, 169  
 Deutsche Psychoanalytische Gesellschaft and, 675  
 Eitingon and, 493  
 First World War and, 586  
 Freud’s medical treatment and, 640  
 Groddeck and, 706  
 on indications/contraindications for psychoanalysis, 809  
 Kemper, Werner Walther and, 910  
 “Lines of Advance in Psycho-Analytic Therapy” and, 980  
 Nazi Germany and, 676, 1045  
 on payment for treatment, 1069  
 on psychoanalytic treatment, 1729  
 on relaxation principle/neo-catharsis, 1465  
 Rosenfeld, Eva Marie and, 1514  
 San Francisco Psychoanalytic Society and Institute and, 1529  
 Tegel clinic and, 1734, 1881  
 Urbantschitsch and, 1828  
 U.S. psychoanalysis and, 992  
 on war neuroses, 1848
- Simmel, Georg, 1631
- Simon, Herbert, 308
- Simon, Janine, 280, 411
- Simon, Théodore, 460
- Simonsen, Hjordis, 1157, 1158
- Sinthome, 1719  
*See also* Symptoms
- Sirk, Douglas, 294
- Sisyphos* (Bernfeld), 169
- Situation phobias, 1273
- Situazione psicoanalitica come campo bipersonale, La* (Baranger), 150
- Sizková, A., 361
- Sjöstrand, Wilhelm, 1699
- Sketches in Psychosomatic Medicine* (Jelliffe), 889
- Skhiri, Taoufik, 1155
- Skin, **1612–1613**  
 adhesive identification and, 24  
 autoeroticism and, 141  
 Bick on, 178, 221, 815, 1170, 1613  
 body image and, 197  
 breastfeeding and, 221  
 cruelty and, 354  
 infant observation and, 816  
 mastery and, 1025  
 tenderness and, 1736  
*See also* Adhesive identification
- Skin-ego, 104–105, **1613–1614**  
 adhesive identification and, 24  
 Bick and, 178  
 body image and, 197  
 dream screen and, 441  
 ego and, 465  
 heroic identification and, 739  
 infant observation and, 816  
 maternal and, 1028  
 object and, 1170  
 protective shield and, 1341  
 psychic envelopes and, 739  
 self-consciousness and, 1569  
 tenderness and, 1736  
*Skin-Ego, The* (Anzieu), 1569  
*See also* Skin-ego
- Slavery, 1437
- Sleep, 1048, 1677  
 Isakower phenomenon and, 440, 441, 874–875  
 night terrors and, 1149, 1231, 1636  
 somnambulism, 84–85, 1636–1637  
 wakefulness and, **1614–1615**  
 “Sleep, the Mouth and the Dream Screen” (Lewin), 440
- Sleepwalking. *See* Somnambulism
- Slipp, Samuel, American Academy of Psychoanalysis and, 59
- Slips of the tongue, 942, 1402–1403, **1615–1616**  
 condensation and, 325  
 conflict and, 325  
 linguistics and, 981  
 substitute formations and, 1681  
*See also* Parapraxes
- Slochower, Harry, 60
- Slow sleep, 1614, 1636
- Smadja, Claude, 420, 1341
- Smelianski, Anna, 876
- Smell, sense of, **1616**
- Smirnoff, Victor Nikolaïevitch, **1617**  
 Association psychanalytique de France and, 122, 123, 1617  
 child analysis and, 610  
*Documents et Débats* and, 426  
 French psychoanalytic establishment split (1964) and, 122, 1617  
*Nouvelle Revue de psychanalyse* and, 1162  
 Société française de psychanalyse and, 1619
- Smith, W. Robertson, 1097, 1321, 1768
- Snake Pit, The* (film), 293
- Snejnevsky, Paval, 1520
- “So-Called Good Hysteric, The” (Zetzel-Rosenberg), 1888
- Sobre psicología y psicoterapia de ciertos estados angustiosos* (Greve Schlegel), 284
- Sobres de Souza, Decio, 215, 217
- Socarras, José Francisco, 315
- Social action, 31
- Social change, 450, 549–550
- Social constructionism, 115
- Social Darwinism, 367, 1278
- Social Development of Young Children* (Isaacs), 873
- Social feeling, **1617–1618**
- Social Interest: A Challenge to Mankind* (Adler), 1018
- Social link, 1632
- Social psychiatry, 238
- Social work, 37
- Sociedad Colombiana de Psicoanálisis, 315
- Sociedad Española de psicoanálisis, 1637
- Sociedad Luso-Español de psicoanálisis, 1637
- Sociedad Psicoanalítica Mexicana, International Federation of Psychoanalytic Societies and, 852
- Sociedade brasileira de psicanálise, 214, 1012, 1250, 1295
- Sociedade brasileira de psicologia analítica, 217
- Sociedade brasileira de psicoterapia de grupo, 217
- Sociedade de psicologia clinica, 217

## INDEX

Volume 1, pp. 1–662; Volume 2, pp. 663–1344; Volume 3, pp. 1345–1892

- Società Psicoanalitica Italiana (SPI), 878, 879–881
- Corrao and, 347–348
- Fornari and, 598
- Gaddini and, 663
- Levi Bianchini and, 963
- Musatti and, 1088
- Rivista di psicoanalisi* and, 663, 878, 879, 881, 1508, 1854
- Servadio and, 1586
- Weiss and, 1854
- Société Belge de Psychanalyse (Belgische Vereniging voor Psychoanalyse), 157–158
- Société Belge de Psychologie Analytique (SBPA), 158
- Société de psychanalyse Freudienne, 612, 1084
- Société de Psychothérapie Nazie, Claude and, 305
- Société française de médecine psychosomatique, 277
- Société française de psychanalyse (SFP), **1618–1620**
- Association psychanalytique de France and, 122, 123
- Berge and, 161, 162, 1619
- child analysis and, 610
- dissolution of, 123, 1348
- Favez and, 561
- founding of, 427, 455, 560, 609, 930, 1618–1619
- Granoff and, 692, 1619
- Lagache and, 427, 935, 1618–1619
- Psychanalyse, La* and, 1347
- Quatrième Groupe and, 1430
- Revue française de psychanalyse* and, 1499
- See also French psychoanalytic establishment split (1953)
- Société psychanalytique de Genève, **1620**
- Société psychanalytique de Montréal, 241–242, 243, 245, **1620–1623**
- Société psychanalytique de Paris (Paris Psychoanalytic Society), 38, 46, **1623–1631**
- Belgian psychoanalysis and, 157, 158
- Berge and, 161, 162
- Berman and, 166–167
- Bernfeld and, 169
- Bonaparte and, 199–200, 608, 988, 1623, 1624, 1626, 1629, 1630
- Borel and, 204
- Bouvet and, 210
- Canadian psychoanalysis and, 242, 243
- Cárcamo and, 247
- CCTP and, 264
- Cénac and, 261, 1630
- Chentrier and, 276
- Chertok and, 277
- child analysis and, 610
- Chilean psychoanalysis and, 284
- Collège de Psychanalystes and, 314
- Confrontation* and, 327
- Congrès des psychanalystes de langue française des pays romans and, 330
- Diatkine and, 410, 411, 1625, 1628, 1630
- Évolution psychiatrique, L'* and, 532, 539, 1623
- Ey and, 539
- Favez and, 560
- Favez-Boutonier and, 559
- founding of, 199–200, 591, 608, 988, 1236
- Granoff and, 692
- Greek psychoanalysis and, 498, 700, 1885
- Held and, 731, 1626
- Hesnard and, 742, 1619, 1623, 1624
- Jury and, 904
- Kestemberg-Hassin and, 911, 1626
- Lacan membership, 608, 929
- Laforgue and, 199, 934, 988, 1236, 1623, 1624, 1625
- Laurent-Lucas-Championnière-Maugé and, 948
- Lebovici and, 954–955, 1625, 1626, 1627, 1630
- Mâle and, 1004
- Marty and, 1016, 1626
- Nacht and, 1101, 1102, 1624, 1625–1626, 1629, 1630
- Nodet and, 1152
- Parcheminey and, 1236, 1623
- Portuguese psychoanalysis and, 1297
- on psychoanalyst role, 1368–1369
- Racamier and, 1435
- recent role of, 612–613
- relaxation psychotherapy and, 1465
- Reverchon-Jouve and, 1493
- Revue française de psychanalyse* and, 1497, 1498, 1499, 1624, 1625, 1630
- Saussure, Raymond de and, 608, 1497, 1536
- Schiff and, 1537
- Schlumberger and, 1541
- Sokolnicka-Kutner and, 1292, 1634
- Spitz and, 1625, 1641
- supervised analysis and, 1693
- Swiss psychoanalysis and, 1700
- Torok and, 1764
- training analysis and, 1770
- Viderman and, 1626, 1627, 1628, 1835
- See also Institut de psychanalyse de Paris
- Société Suisse de Psychanalyse. See Swiss Psychoanalytic Society
- Society for Free Psychoanalytic Research. See Verein für Freie Psychoanalytische Forschung
- Society for Individual Psychology. See Verein für Individualpsychologie
- Society for Psychical Research, 1662
- Society of Analytical Psychology (London), 80
- Sociobiology, archetypes and, 115
- Sociology, **1631–1633**
- Fenichel and, 579
- Fromm and, 651
- magical thinking and, 1000
- Sociometry, 1072
- analytic psychodrama and, 78
- Sociopsychanalysis, 1631
- See also Sociology
- Sogni d'oro* (film), 293
- Sokolik, Zbigniew, 1292
- Sokolnicka-Kutner, Eugénie, **1633–1634**
- Boehm and, 198, 1633
- child analysis and, 1731
- Claude and, 304–305
- Congrès des psychanalystes de langue française des pays romans and, 329
- French psychoanalysis and, 607, 608
- Heuyer and, 304–305, 744
- Laforgue and, 933
- Morgenstern-Kabatschnik and, 1073
- Pichon and, 1283, 1292, 1634
- Polish psychoanalysis and, 1292
- Reverchon-Jouve and, 1493
- Schiff and, 1537
- Société psychanalytique de Paris and, 1623, 1624
- Société psychanalytique de Paris founding and, 199, 988
- Soler, Colette, 1638
- Solidarity International Experimental Home. See Detski Dom
- Solis, Hernan, 1052
- Solitude, 3, 246–247
- Solms-Rödelheim, Wilhelm, Austrian psychoanalysis and, 133, 1858
- Solnit, Albert, Israeli psychoanalysis and, 877
- Somalcoholosis, 413
- Somatic compliance, **1634–1635**
- actual vs. defense neuroses and, 20

Volume 1, pp. 1–662; Volume 2, pp. 663–1344; Volume 3, pp. 1345–1892

- discharge and, 418  
*Somatisation, psychanalyse et science du vivant* (Green), 1410  
 Somatization, 1408  
 disorganization and, 420–421  
 excitation and, 534  
 pain and, 1220  
 passage to the act and, 18  
 reciprocal paths of influence and, 1456  
 Schur on, 1548  
*See also* Psychosomatics  
 Somatognosia, 1571  
 Somatopsyché, 1571  
 Sombart, Werner, 1437  
 “Some Additional Notes on Dream-Interpretation as a Whole” (Freud), 747, 1422  
 “Some Aspects of the Analysis of a Schizophrenic” (Segal), 1708  
 “Some Character-types Met with in Psycho-Analytic Work” (Freud), 269, 272, 1239  
 “Some General Remarks on Hysterical Attacks” (Freud), 1495, 1680  
 “Some Neurotic Mechanisms in Jealousy, Paranoia, and Homosexuality” (Freud), 38, 376–377, 549, 1506  
 “Some Points for a Comparative Study of Organic and Hysterical Motor Paralyses” (Freud), 773–774, 1875  
 “Some Practical Aspects of Psychoanalytic Treatment” (Jones), 130  
 “Some Psychological Consequences of the Anatomical Distinction between the Sexes” (Freud)  
 on castration complex, 253  
 on disavowal, 416  
 on female sexuality, 570  
 on gender identity, 668  
 on negative hallucination, 1125  
 on penis envy, 1245  
 publication of, 641  
 “Some Reflections on Schoolboy Psychology” (Freud), 26, 1836  
 “Some Theoretical Conclusions Regarding the Emotional Life of the Infant” (Klein), 1127–1128  
 “Some Variations in Ego-Feeling” (Federn), 568  
*Sommeil et les Rêves, Le* (Delboeuf), 384  
 Somnambulism, 84–85, **1636–1637**  
 Sonneck, G., 135  
 Sophocles, 107, 984, 985, 986, 1238, 1593  
 Soullairac, André, 1572  
 Soulé, Michel  
 child analysis and, 280, 610, 613, 955, 1732  
 on developmental disorders, 408  
 on encopresis, 504  
 on enuresis, 508  
 on hospitalism, 760  
 on prematurity, 1304  
 on self-consciousness, 1569  
 Soupault, Philippe, Allendy-Nel-Dumouchel on, 45  
 Sources, excitation and, 534  
 Southern California Psychoanalytic Society/Institute, 992, 993  
 Southwood, Harry, 131, 132  
 Soviet Union. *See* Russian/Soviet psychoanalysis  
*Soziale Aspekte der Psychoanalyse* (Caruso), 249  
 Spanish psychoanalysis, **1637–1638**  
 Spatula game, 1651  
 “Special Type of Choice of Object Made by Men, A” (Freud), 252, 342, 1183, 1487, 1593  
 Specific actions, **1638–1639**  
 Specific reaction, 1638  
 Specular relation, 53  
 Specularization, 1840  
 Speer, Ernst, 678  
*Spektrum*, 1698  
*Spellbound* (film), 292, 293, 1365  
 Spencer, Herbert, 85, 539  
 Sperber, Hans, 981, 1707  
 Sperling, Melitta, 48, 1794, 1814  
 SPI. *See* Società Psicoanalitica Italiana  
*Spiegelzauber* (Róheim), 1509–1510  
 Spielrein, Sabina, 8, **1639–1640**, 1702  
 Claparède and, 302  
 Detski Dom and, 402  
 Institut Jean-Jacques Rousseau and, 302  
 Jung and, 639, 747  
 Piaget and, 1282  
 Russian/Soviet psychoanalysis and, 1518, 1519  
 Sechehaye and, 1556  
 Swiss psychoanalysis and, 1620  
*Zeitschrift für psychoanalytische Pädagogik* and, 1886  
 Spinoza, Baruch, 1271, **1640–1641**  
 Althusser and, 53  
 Andreas-Salomé and, 83, 84  
 Breuer and, 224  
 on determinism, 401  
 on doubt, 435  
 Freud’s self-analysis and, 425  
 Goethe and, 686  
 on oceanic feeling, 1181  
 pleasure in thinking and, 1289  
 Rolland and, 1511  
 Spira, Marcelle, 1536, 1701  
 Gressot and, 703  
 Portuguese psychoanalysis and, 1297  
*Spirit of Geometry, The* (Magritte), 1618  
 Spiritualism, 356, 1181  
 Spitteler, Carl, 800, 801, 802, 1523  
 Spitz, René Arpad, **1641–1642**, 1706  
 on abandonment, 2  
 on allergic object relationship, 47  
 on anaclitic depression, 70–71, 760  
 Brazilian psychoanalysis and, 1012  
 Canadian psychoanalysis and, 242  
 on child analysis, 280  
 on clinging instinct, 307, 737  
 Congrès des psychanalystes de langue française des pays romans and, 330  
 Czech psychoanalysis and, 361  
 on defenses, 375  
 on developmental processes, 1330  
 Dolto-Marette and, 427  
 on eight-month anxiety, 1186  
 ethology, 528  
 on fear, 563  
 French psychoanalysis and, 508  
 German psychoanalysis and, 1060  
 on hospitalism, 70, 760  
 Hungarian School and, 764  
 on infant development, 814  
 on infant observation, 817  
 International Federation of Psychoanalytic Societies and, 852  
 Lebovici and, 955  
 on masturbation, 1026  
 on maternal care, 1029  
 on maturation, 1034  
 Nazi Germany and, 1557  
 on oral stage, 1204  
 on phobias, 1275, 1276  
 on primary identification, 1314  
*Psyché* and, 1350  
*Psychoanalytic Study of the Child, The* and, 1382  
 on repetition, 1474  
 Sechehaye and, 1557  
 Second World War and, 1557  
 on social feeling, 1618  
 Société psychanalytique de Paris and, 1625, 1641  
 stages and, 1652  
 on stranger anxiety, 1664

## INDEX

Volume 1, pp. 1–662; Volume 2, pp. 663–1344; Volume 3, pp. 1345–1892

- on sucking, 1682  
 Swiss psychoanalysis and, 1701  
 Tegel clinic and, 1734  
 on uncanny, 1816  
 Split ego. *See* Splitting of the ego  
 Split object. *See* Splitting of the object  
 Splits in psychoanalysis, 25–26, **1643–1645**  
*See also* French psychoanalytic establishment split (1953); French psychoanalytic establishment split (1964); Quatrième Groupe  
 Splitting, **1645–1646**  
 allergies and, 48  
 amnesia and, 64  
 anaclisis and, 69  
 attacks on linking and, 984  
 bizarre object and, 188  
 borderline conditions and, 202  
 castration complex and, 254  
 consciousness and, 334  
 disintegration anxieties and, 418  
 fetishism and, 582–583  
 internal objects and, 850  
 metapsychology and, 1049  
 of the object, 1642  
 pictogram and, 1286–1287  
 Rosenfeld, Herbert on, 1514–1515  
 schizophrenia and, 389, 1647  
 vertical/horizontal, **1650**  
 work of the negative and, 1129, 1130  
*See also* Breast as good/bad object; Splitting of the ego  
 Splitting (Stoller), 1660  
 Splitting of the ego, 466, 1645, **1647**, 1659  
 disavowal and, 415, 416  
 internal objects and, 850  
 paranoia and, 1227, 1647  
 paranoid-schizoid position and, 1233, 1338  
 psychoses and, 1404  
 purified-pleasure-ego and, 1423  
 scotomization and, 1554  
 self and, 1579  
 voyeurism and, 1843  
*See also* Projective identification  
 “Splitting of the Ego in the Process of Defense, The” (Freud), 415, 582, 641, 1354, **1647–1648**, 1665  
 Splitting of the object, **1642–1643**, 1645, **1648–1649**  
 Splitting of the personality, 1672  
 Splitting of the subject, **1649–1650**  
 Althusser on, 53  
 Spock, Benjamin, 1851  
 SPP. *See* Société psychanalytique de Paris  
 Springer-Kremser, Marianne, Austrian psychoanalysis and, 135  
 Springthorpe, John William, Australian psychoanalysis and, 130  
 Squiggle game, **1650–1651**  
 Staabs, Gertrude von, 1395  
 Stability  
 death instinct and, 371  
 discharge and, 417  
 dualism and, 449  
 pleasure principle and, 174  
 “Stade du miroir, Le” (Lacan), 608  
 Staff, Clement, *Psychoanalysis* and, 1380  
 Stages, **966–967**, 1184–1185, **1651–1653**  
*See also* Libidinal development  
*See also specific stages*  
 “Stages in the Development of the Sense of Reality” (Ferenczi), 288  
*Stages of Life, The* (Jung), 1055  
 Stajner-Popovic, Tamara, 1885  
 Stammering, **1653–1654**  
*Standard Edition of the Complete Psychological Works of Sigmund Freud*, **1654–1656**, 1662–1663, 1664  
 on anaclisis, 68, 698, 753–754  
 on anticathexes, 94  
 International Psychoanalytical Association and, 1558, 1663  
 “Standards and Principles of Psychoanalytic Education” (APA), 62  
 Stärcke, August, Dutch psychoanalysis and, 1132, 1676  
 State of being in love, **1656**  
*Statut de l’affect dans la psychothérapie des démences* (Grosclaude), 390  
 Staub, Hugo, 43, 1734  
 Steele, Bernard, 934  
 Stegmann, Arnold Georg, 674  
 Stegmann, Margarete, 674  
 Steimback, M., 1637  
 Stein, Conrad  
*Bloc, Le—Notes de la psychanalyse* and, 195  
 Collège des Psychanalystes and, 314, 1835  
 Colloque sur l’inconscient and, 314, 315, 610  
*Confrontation* and, 327  
 on ethics, 526  
*Études Freudiennes* and, 528, 613, 807  
 on female sexuality, 574  
 French psychoanalysis and, 613  
*Inconscient, L’* and, 129–130, 611, 806, 807, 1835  
 on infantile psychosis, 825  
*Interprétation* and, 864  
 Schlumberger and, 1542  
 Société psychanalytique de Paris and, 1626, 1628  
 on training analysis, 1770  
 Videman and, 1835  
 Stein, Franz, 652  
 Stein, Ruth, 877  
 Steiner, Maximilian, 959  
 Steiner, Riccardo, 698, 739–741, 1233  
 Stekel, Wilhelm, 638, 1643, **1656–1658**  
 Adler, Alfred and, 25  
 on anxiety, 1131–1132  
 on anxiety neurosis, 1136–1137  
 on applied psychoanalysis, 108  
 on cryptomnesia, 356  
 Greenson and, 702  
 Gross and, 708  
 International Psychoanalytical Association and, 854, 860  
 neopsychoanalysis and, 1131  
 on ontogenesis, 1197  
*Psychoterapia* and, 1411  
 psychotherapy and, 1411  
 Silberer and, 1608  
 Wittels and, 1869  
*Zentralblatt für Psychoanalyse* and, 884, 1887  
*Stellung-da*. *See* Representability  
 Stengel, Erwin  
 Lehrinstitut der Wiener psychoanalytischen Vereinigung and, 959  
 on multilingualism, 1086  
 Stengers, Isabelle, 277, 1628, 1774  
 Stephanotos, Gerosimos, Greek psychoanalysis and, 701  
 Stephen, Adrian Leslie  
 Bloomsbury Group and, 695  
*International Journal of Psychoanalysis, The* and, 853  
 Stephen, Karen  
 Bloomsbury Group and, 695  
 Tavistock Clinic and, 1728  
 Sterba, Richard F., **1658–1659**  
 Argentinian psychoanalysis and, 117  
 Bettelheim and, 172  
 on Bibring, 176  
 Canadian psychoanalysis and, 242  
 Eissler-Selke and, 492  
 Happel and, 725  
 Japanese psychoanalysis and, 887, 921  
 Langer and, 941

Volume 1, pp. 1–662; Volume 2, pp. 663–1344; Volume 3, pp. 1345–1892

- Lehrinstitut der Wiener psychoanalytischen Vereinigung and, 959  
 on therapeutic alliance, 1741, 1789  
 Waelder and, 1845  
 Walter and, 1847  
 Wiener psychoanalytische Vereinigung and, 1857  
*Zeitschrift für psychoanalytische Pädagogik* and, 1886
- Sterba-Radanowicz-Hartmann, Editha, **1658**, 1659  
 Canadian psychoanalysis and, 242  
 Happel and, 725  
 Lehrinstitut der Wiener psychoanalytischen Vereinigung and, 959  
 Vienna Ambulatorium and, 959  
*Zeitschrift für psychoanalytische Pädagogik* and, 1886
- Stern, Alfred K., Chicago Psychoanalytic Institute and, 278
- Stern, Anne-Lise, Aubry Weiss and, 129
- Stern, Daniel N.  
 on biotrauma, 90  
 on developmental processes, 1330  
 on early interactions, 454  
 on infant development, 815  
 on infantile neurosis, 822  
 on intersubjective/intrasubjective dichotomy, 867  
 on lack of differentiation, 932, 933  
 Lebovici and, 955  
 on maternal care, 1029  
 on music, 1089  
 on nonverbal communication, 1154  
 on object, 1170  
 on pregenital stage, 1186  
*Psychoanalytic Study of the Child, The* and, 1382  
 on puerperal psychoses, 1422  
 on secrets, 1560–1561  
 on self, 1567  
 on true/false self, 1582  
 on unconscious fantasies, 1818
- Stevenson, Robert Louis, 429
- Stittelman, Lucette, Martinican psychoanalysis and, 1014
- Stittelman, Pierre, Martinican psychoanalysis and, 1014
- Stöcker, Helene, German psychoanalysis and, 675
- Stoddart, Henry Butter, British psychoanalysis and, 696
- Stoléro, Serge, Lebovici and, 955
- Stoller, Robert J., **1659–1660**  
 on gender identity, 668–669, 757, 1324  
*Nouvelle Revue de psychanalyse* and, 1163  
 on perversion, 1256  
 on transsexualism, 1799  
 on voyeurism, 1843
- Stolorow, Robert  
 on prereflective unconscious, 1307  
 on unvalidated unconscious, 1827
- Stolorow, Robert D., on self, 1567
- Stone, Leo, III:pl.11, **1660–1661**, 1885
- Storer, Adolf Josef, Internationaler Psychoanalytischer Verlag and, 861
- Storfer, Adolf Josef, 1659, **1661–1662**  
*Almanach der Psychoanalyse* and, 49–50  
*Gesammelte Schriften* and, 680  
*Psychoanalytische Bewegung, Die* and, 1387  
*Secrets of a Soul, The* and, 1562
- Stork, Hélène, 1775
- Stork, Jochen, *Journal de la psychanalyse de l'enfant* and, 896
- Störungen der Liebesfähigkeit beim Weibe, Die* (Kemper), 910
- Störungen des Trieb- und Affektlebens* (Stekel), 1657
- “Stottern eine psychoneurose und seine Behandlung durch die Psychoanalyse” (Eder), 461
- Strachey, James Beaumont, 1654–1655, **1662–1663**, 1669–1670  
 Bettelheim on, 173  
 Bloomsbury Group and, 695  
 British psychoanalysis and, 696–697  
 Burke and, 214  
 Controversial Discussions and, 343, 344, 697  
 on disavowal, 415  
 on drives, 444, 446  
 on empathy, 502  
 on evenly-suspended attention, 531  
 Hogarth Press and, 753  
 Imago Publishing Company and, 802  
*International Journal of Psychoanalysis, The* and, 229, 853  
 Internationaler Psychoanalytischer Verlag and, 861  
 Jones and, 893  
 Lanzer and, 944  
 on libido, 969  
 Matte-Blanco and, 1033  
 on maturation, 1034  
 on mutative interpretation, 1089–1090  
 photograph of, III:pl.13  
 on primary identification, 1314  
 on “Project for a Scientific Psychology, A”, 1333, 1334  
 on resolution of the transference, 1491  
*Sigmund Freud: Life and Work* and, 974  
 on socopophilia, 1553  
 Spanish psychoanalysis and, 1637  
 on time, 1757  
 Winnicott and, 1861
- Strachey, Lytton, 695, 1662
- Strachey-Sargent, Alix, 1654–1655, 1662–1663, **1663–1664**  
 Bloomsbury Group and, 695  
 Hogarth Press and, 753  
*Inhibitions, Symptoms, and Anxiety* and, 833  
 Jones and, 893  
 Klein and, 697, 914  
 photograph of, III:pl.12  
 “Stradanie i tvortchestvo v Dostoïevskoni” (Rosenthal), 1515
- Strange situation, 125, 822
- Stranger anxiety, 563, **1664–1665**
- Stranger’s-face phobia, 1664
- Strata. *See* Stratification
- Stratification, 111, 112, **1665–1666**
- Straus, Erwin, 1267
- Strauss, David Friedrich, 1511
- Strauss, Marianne, 1465
- Stricker, Salomon, 1838
- Strindberg, August, 1697
- “Striving for Autonomy and Regressive Object Relationship, The” (Spock), 1851
- Strohmayer, Wilhelm, German psychoanalysis and, 674
- Stromme, Irgens, 1698
- Strotzka, Hans, Austrian psychoanalysis and, 133, 135
- Strozier, Charles B., Chicago Psychoanalytic Institute and, 278, 279
- Structural anthropology, 1604
- “Structural Forms of the Feminine Psyche” (Wolff), 1872
- Structural Stability and Morphogenesis* (Thom), 256
- Structural theories, **1666–1668**  
*See also* Structural theory
- Structural theory, 476, 777–778, 1049  
 activity/passivity and, 17  
 agency and, 33  
 cathexis and, 260  
 censorship and, 263  
 change and, 267  
 character and, 269, 270  
 collective psychology and, 311  
 conflict and, 326



## INDEX

Volume 1, pp. 1–662; Volume 2, pp. 663–1344; Volume 3, pp. 1345–1892

- defenses and, 375  
*Ego and the Id, The* on, 470–471  
 ego psychology and, 486  
 Freud, Anna on, 472  
 fusion/defusion and, 659  
 latent/manifest dream elements and, 1008  
 modern conflict theory and, 1065, 1066  
*New Introductory Lectures on Psychoanalysis* on, 1145  
 object relations theory on, 1177  
 operational thinking and, 1198  
 orality and, 1202  
 Other and, 1212–1213  
 progressive neutralization and, 1331  
 prohibition and, 1332  
 psychic apparatus and, 1351  
 psychic causality and, 1354  
 repression and, 1482  
 Schur on, 1548  
 self-hatred and, 1571  
 self-preservation and, 1576  
 topographical point of view and, 1760  
 U.S. psychoanalysis and, 1825, 1826  
*See also* Metapsychology  
 Structural truth, 1468  
 Structuralism, **1668–1669**  
 Deleuze/Guattari and, 98  
 French psychoanalysis and, 610  
 perversion and, 1258–1259  
*Structuration dynamique dans la schizophrénie* (Pankow), 1222  
 Structure, 1666  
 Stuchlik, Jaroslav, Czech psychoanalysis and, 360  
*Student of Prague, The*, 429  
 Student protests (1960s), 612, 699, 931  
*Studien über Hysterie* (Bleuler), 194  
*Studienausgabe* (Freud), **1669–1670**  
 Studiengesellschaft für praktische Psychologie, 678  
*Studies in a Dying Colonialism* (Fanon), 550  
 “Studies in the Prehistory of Psychoanalysis” (Andersson), 82  
*Studies in Word Association* (Jung), 1779  
*Studies on Hysteria* (Freud and Breuer), 87, **1670–1672**, 1672, 1714, 1716  
 on adolescence, 26, 28  
 on amnesia, 63  
 archeological metaphors in, 114  
 on belief, 158  
 Bernheim on, 170  
 Breuer and, 225  
 “Cécilie M.” case, 239  
 case histories in, 250  
 on cathexis, 259  
 on censorship, 262  
 on change, 267  
 cinema and, 293  
 on complexes, 319  
 on compulsion, 322  
 on creativity, 352  
 on cure, 358–359  
 on Darwinism, 366  
 on daydreams, 555, 1493–1494  
 Delboeuf and, 384  
 Deuticke and, 403  
 on developmental disorders, 408  
 on developmental processes, 1329  
 on “Elisabeth von R.” case, 495–496  
 on “Emmy von N.” case, 499–500, 1076–1077  
 on ethics, 525  
 on facilitation, 543  
 on fantasy, 550  
 on free association, 616  
 on fright, 648  
 on heredity of acquired characters, 736  
 on hypnoid states, 768  
 on indications/contraindications for psychoanalysis, 808–809  
 on “Katharina” case, 26, 909  
 on “Lucy R.” case, 495, 997–998  
 on memory, 1041–1042  
 on mnemonic symbols, 1061  
 on mnemonic traces, 1064  
 on modesty, 1067  
 on negative transference, 1127  
 on Oedipus complex, 1183–1184  
 on orgasm, 1209  
 on overdetermination, 1216  
 on pain, 1280  
 on phylogenesis, 1277  
 on pleasure principle, 1290  
 on primal scene, 1310  
 on prohibition, 1331  
 on psychic energy, 1355  
 on psychoanalyst role, 74  
 psychoanalytic nosography and, 1374  
 on psychoanalytic treatment, 1384  
 on psychosomatic limit, 1410  
 on puberty, 1420  
 on quantitative/qualitative dimensions, 1427  
 on religion, 1466  
 on repetition, 1472  
 on repression, 1482  
 on resistance, 1488  
 on seduction scenes, 1565  
 on stratification, 1665  
 on tics, 1756  
 on transference relationship, 1788  
 on unconscious, 1818  
 on wishes, 1867  
 on work, 1875  
 on working over, 1878  
*See also* “Anna O.” case  
*Study of Organ Inferiority and its Psychological Compensation, A* (Adler), 25  
*Study of Psychopathology, A* (Lapuz), 1268  
 Stupidity, arrogance and, 121  
 Stuttering, Eder on, 461  
 Subconscious, **1672–1673**  
 Subject, **1673–1674**  
 castration of, 1676–1677  
 incompleteness and, 806  
 philosophy and, 1271  
 signifiers and, 1605  
 truth and, 1805  
 Subject of the drive, **1674–1675**  
 Subject of the unconscious, **1675–1676**  
 Subjectification, 1656, 1674  
 Subject’s castration, **1676–1677**  
 Subject’s desire, **1677–1678**  
 Sublimation, **1678–1680**  
 anal eroticism and, 514  
 Bornstein on, 205  
 character and, 269  
 civilization and, 298, 299  
 defenses and, 375  
 desexualization and, 399  
 directed daydreams and, 414  
 on drives, 447  
 ego and, 463, 464  
 ego ideal and, 480  
 fatherhood and, 558  
 Freud’s self-analysis and, 425  
 friendship and, 647  
 identification with the aggressor and, 792  
 incest and, 804  
 latency period and, 945  
 mastery instinct and, 917  
 neurotic defenses and, 1142  
 pleasure in thinking and, 1289  
 reaction-formations and, 1449, 1679  
 reciprocal paths of influence and, 1456  
 reparation and, 1471–1472

Volume 1, pp. 1–662; Volume 2, pp. 663–1344; Volume 3, pp. 1345–1892

- repetition and, 1474  
 rituals and, 1505  
 sexual theories of children and, 1591  
 sexuality and, 1594  
 Sharpe on, 1599  
 thought and, 1747  
 unconscious fantasies and, 1817  
 urethral eroticism and, 517  
 work and, 1876  
 Substitute formations, **1680–1681**  
   displacement and, 422  
   metaphor and, 1047, 1048  
   reaction-formations and, 1449, 1681  
 “Subversion of the Subject and the Dialectic of Desire in the Freudian Unconscious, The” (Lacan), 554, 693, 895  
 Sucking, **1681–1683**  
   Abraham, Karl on, 6, 1682  
   anaclysis and, 1682, 1752–1753  
   autoeroticism and, 141, 1681–1682  
   erotogenic zones and, 518  
   oral eroticism and, 515  
   orality and, 1202, 1203, 1204  
   self-preservation and, 1575  
   *See also* Breast; Breastfeeding  
   Suckling. *See* Breastfeeding  
   Sudden involuntary ideas, **1683**  
   *Suddenly, Last Summer* (film), 293  
   Suffering, **1683–1684**  
   Sugar, Nikola, 1884–1885  
   Suggestibility, 1684  
   Suggestion, **1684–1686**  
     autosuggestion, 144  
     Baudouin on, 1431–1432  
     Bernheim on, 170  
     cure and, 358  
     fundamental rule and, 655  
     Liebeault on, 973  
     lies and, 971  
     transference and, 1776  
   *Suggestion and Autosuggestion* (Baudouin), 155, 1432  
   Suicidal behavior, **1686–1687**  
   Suicide, **1687–1688**  
     Bettelheim and, 173  
     megalomania and, 1036  
     melancholia and, 1082  
     paranoia and, 1230  
     passage to the act and, 1390  
     self-punishment and, 1577  
     *See also* Suicidal behavior  
   Sullivan, Harry Stack, **1688–1689**  
     Association for the Advancement of Psychoanalysis and, 1558  
     Brazilian psychoanalysis and, 215  
     Chinese psychoanalysis and, 286  
     on consensual validation, 419  
     definition of psychoanalysis and, 1364  
     Fromm and, 651  
     Fromm-Reichmann and, 652  
     Horney-Danielson and, 759  
     object relations theory and, 1176  
     photograph of, III:pl.14  
     on schizophrenia, 1540  
     Swedish psychoanalysis and, 1699  
     Thompson and, 1745, 1746  
     Washington Psychoanalytic Society and, 1849, 1850  
   Sulloway, Frank  
     on biological bedrock, 183  
     Freud biography by, 642, 1197  
   Sum of excitation, **1689–1690**  
   Suomen Psykoanalyttinen Yhdistys, 584  
   Superego, 1610, 1678, **1690–1692**  
     alcoholism and, 41  
     allergies and, 48  
     altruism and, 54  
     antilibidinal ego and, 96, 97  
     anxiety and, 100  
     archaic and, 111, 112  
     archaic mother and, 113  
     “as if” personality and, 122  
     Bergler on, 153  
     Bornstein on, 205  
     breast as good/bad object and, 219  
     castration complex and, 254–255  
     censorship and, 263  
     character and, 269, 274  
     *Civilization and Its Discontents* on, 297  
     cruelty and, 355  
     cultural transmission and, 357  
     death instinct and, 372, 1691  
     delusions and, 386  
     depression and, 394  
     early Oedipus complex and, 1188  
     ego and, 465, 1690  
     *Ego and the Id, The* on, 471, 479  
     ego ideal and, 479–480, 1106  
     ethics and, 525, 526  
     failure neurosis and, 544  
     father and, 526  
     fatherhood and, 558  
     female sexuality and, 1636  
     fusion/defusion and, 658  
     guilt and, 297, 471, 716–718  
     humor and, 762–763  
     id and, 778  
     idealization and, 783  
     identification and, 789  
     identification with the aggressor and, 792–793  
     imago and, 801  
     incest and, 1594  
     internal objects and, 849–850  
     jouissance and, 895  
     Klein on, 915  
     latency period and, 946  
     masturbation and, 205, 1026  
     melancholia and, 1038  
     modesty and, 1067  
     moral masochism and, 1071, 1072, 1691  
     narcissistic neuroses and, 1113–1114  
     object-choice and, 1174  
     paranoid position and, 1231  
     penis envy and, 1246  
     pleasure ego/reality ego and, 1288  
     projective identification and, 121  
     punishment dreams and, 1422  
     religion and, 297  
     repression and, 1479  
     self-hatred and, 1571  
     self-punishment and, 1577  
     sucking and, 1682  
     symptoms and, 1715  
     *See also* Structural theory  
   Superego anxiety, death and, 370  
   Superiority, masculine protest and, 1018  
   Supersession, 1674  
   Superstition  
     animistic thought and, 86  
     belief and, 158  
     death and, 370  
     déjà vu and, 381  
     repetition and, 1473  
   Supervised (control) analysis, 602–604, **1692–1693**  
   *Suppressed Madness of Sane Men, The* (Blackett-Milner), 190  
   Suppression, **1693–1694**  
   *Sur*, 116  
   “*Sur le mouvement psychoanalytique*” (Maeder), 89  
   “*Sur les Traitements Psychotherapiques Courts d’Inspiration Freudienne chez les Enfants*” (Parcheminey and Pichon), 1236  
   “*Sur l’israélisme de Freud*” (Hesnard), 742  
   Suréna, Guillaume, 1014

## INDEX

Volume 1, pp. 1–662; Volume 2, pp. 663–1344; Volume 3, pp. 1345–1892

- Surin, Jean-Joseph, 266
- Surplus repression, 1018
- Surrealism, **1695–1696**  
Breton and, 223–224  
Choisy on, 290  
Embirikos and, 498  
Held and, 731  
literature and, 987  
Martinican psychoanalysis and, 1014  
Société psychanalytique de Paris and, 1624  
*Surrealist Manifesto* (Breton), 224, 290, 1695  
*Surviving and Other Essays* (Bettelheim), 173
- Survivor guilt, failure neurosis and, 544
- Suspended attention, 127
- Sutherland, John D.  
British psychoanalysis and, 699  
*International Journal of Psychoanalysis, The* and, 853  
Laing and, 937  
Tavistock Clinic and, 1728
- Suttie, Ian, 1457–1458
- Svenska Psykoanalytiska Förening (Swedish Psychoanalytic Society), 82, 1698–1699
- Svevo, Italo, 1853  
*Psychoanalytische Bewegung, Die* and, 1387
- Swales, Peter, on “Cäcilie M.” case, 239, 240
- Swastika, 1023
- Sweden, 188–189
- Swedish psychoanalysis, **1697–1700**  
Andersson and, 81–83  
Jekels and, 888
- Swedish Psychoanalytic Society. *See* Svenska Psykoanalytiska Förening
- Swedish Society for Holistic Psychotherapy and Psychoanalysis, 1699
- Swift and Carroll* (Greenacre), 702
- Swiss Medical Society for Psychoanalysis, 1549–1550, 1644
- Swiss psychoanalysis  
Claparède and, 302  
Flournoy, Henri and, 591  
French-speaking, **1700–1702**  
German-speaking, **1702–1704**  
Gressot and, 703  
Pfister and, 1260, 1513, 1549, 1550, 1700, 1702, 1703  
Société psychanalytique de Genève and, 1620  
*See also* Swiss Psychoanalytic Society
- Swiss Psychoanalytic Society (SGPsa), 1700, 1703  
Brun and, 231  
Chilean psychoanalysis and, 284  
Claparède and, 302  
Flournoy, Henri and, 591  
Gressot and, 703  
Oberholzer and, 1167  
Pfister and, 1260, 1513  
Rambert and, 1442  
Rorschach and, 1513  
Sarasin and, 1534  
Saussure, Raymond de and, 1536  
Schneider and, 1544  
Schweizerische Ärztgesellschaft für Psychoanalyse and, 1549–1550  
Second World War and, 1557  
Spanish psychoanalysis and, 1637  
Switzerland (French-speaking), 449–450, 608  
*See also* Swiss psychoanalysis  
Switzerland (German-speaking)  
Meng and, 1044  
*See also* Swiss psychoanalysis
- Swoboda, Hermann, 667, 1587, **1704–1705**
- Sydenham, Thomas, 1414
- Sydow, Eckhard von, 198
- Symbiosis, **1705–1706**  
Benedek on, 160  
Bion on, 1464, 1706  
individuation and, 811  
infantile psychosis and, 825, 826  
Mahler-Schönberger on, 1001  
self-mutilation and, 1573
- Symbiotic relation. *See* Symbiosis
- Symbolic, the, **1710–1711**  
death instinct and, 372  
Ferenczi and, 1739  
*Fort-da* game and, 600, 927  
L and R schemas and, 927  
phallus and, 1264, 1710  
Real and, 1453  
*See also* Borromean knot
- Symbolic castration, 428
- Symbolic equation, **1708–1709**, 1711
- Symbolic father, 1452  
*See also* Name-of-the-Father
- Symbolic identification. *See* Imaginary identification/symbolic identification
- Symbolic mother, 1452–1453
- Symbolic order, 1139, 1327  
*See also* Symbolic, the
- Symbolic realization, 1556, **1709–1710**
- Symbolic Wounds: Puberty Rites and the Envious Male* (Bettelheim), 173
- “Symbolique, l’imaginaire et le réel, L” (Lacan), 1453
- Symbolism, **1706–1708, 1711–1712**  
alcoholism and, 41  
analytical psychology and, 79, 80  
archaic and, 112  
Blackett-Milner on, 190  
breastfeeding and, 220  
Caruso and, 249  
death and, 370  
dreams and, 437, 441–442, 1559, 1798, 1811  
feminist views of psychoanalysis and, 578  
individuation and, 812  
Jung on, 864  
representation and, 782
- Symbolization, **1712–1714**  
act/action and, 9  
anagogical interpretation and, 71  
anxiety and, 101  
autism and, 137  
“Cäcilie M.” case and, 240  
dementia and, 389  
dream symbolism and, 441, 442, 654–655  
encopresis and, 504  
ethology and, 528  
female sexuality and, 365  
frame of psychoanalytic treatment and, 606  
functional phenomenon and, 654  
object and, 1170, 1171  
phallus and, 365  
primitive words and, 4  
Real and, 1454  
representation and, 782  
somatic compliance and, 1635  
suffering and, 1684
- Symptom-formation, **1716–1718**  
flight into illness and, 590  
reciprocal paths of influence and, 1456  
repression and, 1491–1492  
reversal into the opposite and, 1495
- Symptoms, **1714–1715**  
condensation and, 325  
conflict and, 325  
inhibition and, 832, 833  
Lacan on, 38, 1454, **1718–1719**  
*See also* Symptom-formation
- Synchronicity, 1029, **1719–1720**
- “Synchronicity: An Acausal connecting principle” (Jung), 1720
- Syntagmatic axis, 1606
- Synthesis, 1672

Volume 1, pp. 1–662; Volume 2, pp. 663–1344; Volume 3, pp. 1345–1892

- Systems, 32–33, 1297, 1371, **1720–1721**
- Szasz, Thomas, 277
- Székács, István, 766
- Székely, Béla, 116–117
- Székely, Edith, 1698
- Székely, Lajos, 1698
- Szondi, Leopold, III:pl.15, 1395, **1721–1722**
- Szondi Institute, 1721
- Szondi Society, 1721
- Szondiana* (Szondi), 1722
- Szwec, Gérard, 48, 420, 1341
- T**
- Taboo, 85, 434, 1504, **1723–1724**
- “Taboo of Virginité, The” (Freud), 342–343, **1724–1725**
- on castration complex, 251, 252
- on fascination, 556
- on narcissism of minor differences, 1109
- on taboo, 1724
- Tact, **1725–1726**, 1729
- Tadmor, Gad, 877
- Tagtraum-Traumdichtung* (Andreas-Salomé and Anna Freud), 83
- Taguieff, Pierre-andré, 1436–1437
- Tähkä, Veikko, 584
- Taine, Hippolyte, 1569
- Tallaferro, Alberto, 117
- Tames, Ruben, 1052
- Tamez Morales, Alejandro, 566
- Tamm, Alfhild, 584, 1157, 1698, 1699
- Tandler, Julius, 1432
- Tannenbaum, Samuel, 1608
- Tantum, Digby, 699
- Taoism, 921
- Tarde, Gabriel de, 1685
- Tartarin de Tarascon* (Daudet), 1098
- TAT (Thematic Apperception Test), 1087, 1395, 1398
- “Taucher, Der” (Schiller), 1539
- Tausk, Viktor, **1726–1727**
- on alcoholism, 41, 42
- Andreas-Salomé and, 83
- Eder and, 460
- on ego boundaries, 474
- epistemology and, 1370
- on lies, 971
- on narcissism, 1106, 1111
- Nunberg and, 1165
- Roazen on, 642
- on schizophrenia, 1193–1194
- on splitting, 1647
- on training analysis, 1769
- Tautermann, P., 361
- Tavistock Clinic, **1727–1728**
- analytic psychodrama and, 78
- Balint groups and, 147
- Bick and, 177, 1728
- British Psycho-Analytical Society and, 230, 1502
- British psychoanalysis and, 698, 699, 700
- child analysis and, 1732
- Italian psychoanalysis and, 880
- Journal de la psychanalyse de l'enfant* and, 896
- Raimbault, Émile and, 1442
- Rees and, 1457–1458, 1728
- Robertson and, 1509
- Tustin and, 1809
- Wittkower and, 1728, 1870
- Tchertok, Lejb. *See* Chertok, Léon
- Teaching of Dynamic Psychiatry, The* (Bibring-Lehner), 177
- Tears, allergies and, 47, 48
- Technik der Individualpsychologie, Die* (Adler), 25
- Technik der Psychoanalyse* (Rank), 1729
- Technique. *See* Child analysis; Psychoanalytic treatment
- Technique and Practice of Psychoanalysis, The* (Greenson), 703
- Technique of Analytical Psychotherapy* (Stekel), 1657
- Technique of Psycho-Analysis, The* (Glover), 684
- Tegel clinic, **1734**, 1881
- Teilhard de Chardin, Pierre, 290, 609, 1350, 1739
- Telepathy, 112, 1180–1181, 1457, **1735**
- Temple, Nicholas, 1727
- Tempo psicanalítico*, 217
- Temporality. *See* Time
- Temps modernes, Les*, 612, 1009
- Temps vécu, Le* (Minkowski), 532, 1057
- “Tendance convergente de la regression narcissique, La” (Botella and Botella), 1116
- Tenderness, **1735–1737**
- “Termination of Analysis” (Ferenczi), 1737
- Termination of treatment, 76–77, 1385, **1737–1738**
- active technique and, 16
- frame of psychoanalytic treatment and, 606–607
- “Lines of Advance in Psycho-Analytic Therapy” and, 979–980
- Real and, 1454
- weaning and, 1852
- “Wolf Man” case and, 76, 650, 979, 1738
- working-through and, 1880
- Terr, Lenore, 1382
- Terror. *See* Fright
- Teruel, Guillermo, 1832, 1833
- Texte: Psychoanalyse, Ästhetik, Kulturkritik*, 135
- Thackeray, William, 224
- Thalassa*, 766
- Thalassa: A Theory of Genitality* (Ferenczi), 66–67, 113, 447, 581, **1738–1739**
- Thanatos. *See* Death instinct
- Theiler, Pauline, 1609
- Thematic Apperception Test (TAT), 1087, 1395, 1398
- “Theme of the Three Caskets, The” (Freud), 1080, 1610, **1739–1740**
- Thenon, Jorge, 116
- Théorie et Pratique du Rêve-éveillé* (Desoille), 400
- Theory of Psychoanalytic Technique* (Menninger), 1045
- “Theory of Symbolism, The” (Jones), 655, 893, 1608, 1707
- “Theory of the parent-infant relationship, The” (Schur), 1549
- “Theory of the Parent-Infant Relationship, The” (Winnicott), 813
- Theory of Thinking, A* (Bion), 50, 51, 121, 171, 1566–1567, 1749
- Therapeutic alliance, **1740–1741**, 1888
- child analysis and, 1732, 1733, 1783–1784
- transference relationship and, 1789
- See also* Counter-transference; Psychoanalyst role; Transference
- Therapeutic Experience and Its Setting, The* (Stone), 1661
- Therapeutic Group Analysis* (Foulkes), 601, 709
- Thibaudet, Albert, 424
- Thiesson, Gaston, 196
- Thing, the, **1743**, 1814
- Thing-presentations, 106, 847, **1741–1743**, 1873, 1874
- Thinking, Feeling and Being* (Matte-Blanco), 284, 1033
- Third area, 1650
- This, Bernard, 428, 984
- This, Claude, 428
- Thom, René, 241, 256, 1055
- Thomä, Helmut, 1520
- Thomas, Madeleine, 1395
- Thomas Woodrow Wilson, Twenty-eighth President of the United States. A*

## INDEX

Volume 1, pp. 1–662; Volume 2, pp. 663–1344; Volume 3, pp. 1345–1892

- Psychological Study* (Freud and Bullitt), 234, 235, 311, 485, 750, 1293, **1743–1745**, 1856
- Thompson, Clara M., **1745–1746**  
American Academy of Psychoanalysis and, 58  
Association for the Advancement of Psychoanalysis and, 1558, 1745–1746  
Ferenczi and, 59, 329  
Fromm and, 651  
Horney-Danielson and, 759  
Stone and, 1661  
Sullivan and, 1688  
Tavistock Clinic and, 1728  
Washington Psychoanalytic Society and, 1849, 1850
- Thompson, Francis, 1599
- Thought, 44, 332, **1746–1748**
- Thought identity, 536, 1249, **1748–1749**
- Thought-thinking apparatus, **1749–1750**
- Thought vs. action, 18
- “Thoughts for the Times on War and Death” (Freud), 639, **1750–1751**  
on altruism, 53  
on character formation, 272  
First World War and, 586  
on instinctual impulse, 840  
on knowledge instinct, 918  
on mourning, 1080  
on racism/anti-Semitism, 1438  
on reaction-formations, 1449  
“Why War?” and, 1856
- “Three Areas of the Mind, The” (Balint), 151
- Three Essays on the Theory of Sexuality* (Freud), **1751–1755**  
on activity/passivity, 17  
on adolescence, 26  
on aggression, 33  
on amnesia, 63–64, 819–820, 820  
on anaclysis, 68  
on anal eroticism, 514  
on anality, 72  
on autoeroticism, 141  
Balint and, 1314  
on biological bedrock, 182  
on castration complex, 251, 252  
on character, 269, 272  
childhood and, 280  
on choice of neurosis, 288  
on conflict, 326  
on constitution, 334  
on coprophilia, 346  
on cruelty, 354  
on drives, 445, 446  
on ego, 463  
on ego-libido/object-libido, 485  
on Eros, 512–513  
on erotogenic masochism, 517  
on erotogenic zones, 1205–1206  
on erotogenicity, 520  
on exhibitionism, 535  
*Fackel, Die* and, 924  
on fascination, 556  
on feces, 564  
on fetishism, 582, 1485, 1616  
on fixation, 588  
on heterosexuality, 743–744  
on homosexuality, 757, 758  
on idealization, 783  
on identification, 787  
on incest, 804  
on infant development, 814  
on infantile sexual curiosity, 1590  
on infantile sexuality, 1593  
on instinctual impulse, 840  
on knowledge instinct, 917, 918  
on libidinal development, 965  
on libidinal stages, 967  
on libido, 967, 968, 970  
“Little Hans” case and, 75  
Mâle and, 1004  
on masculinity/femininity, 572, 1019  
on masochism, 1021  
on mastery, 1023, 1025  
on masturbation, 1026  
on narcissism, 1105  
on object-choice, 1174  
on object loss, 993–994  
on ontogenesis, 1197  
on oral eroticism, 516  
on oral-sadistic stage, 1203  
on orality, 1202  
on organic repression, 1207  
on organization, 1208  
on orgasm, 1209  
on otherness, 1214  
on pairs of opposites, 1220  
on partial drives, 1240  
on perversion, 1255, 1257  
on pleasure principle, 1290–1291  
on pregnancy fantasy, 1302  
on primary need, 1316  
on psychic representative, 1358  
on psychosexual development, 1405–1406  
on psychosomatic limit, 1410  
on puberty, 1420  
publication of, 638, 802  
on reaction-formations, 1449  
on reciprocal paths of influence, 1456  
on regression, 1460  
on repression, 1483  
on rituals, 1503  
on sadism, 1525  
on sadomasochism, 1527  
on screen memories, 1555  
on seduction scenes, 1565–1566  
on seduction theory, 1564  
on sense of smell, 1616  
on sexual drives, 1589  
on shame, 1599  
on signal anxiety, 1604  
on skin, 1612  
on thought, 1746  
on thumbsucking, 1681  
on trauma, 328  
on urethral eroticism, 517  
on violence instinct, 1839  
on voyeurism, 1843  
on work, 1876
- Three Faces of Eve, The* (film), 293
- Thrills and Regression* (Balint), 148, 160
- Thumbsucking. *See* Sucking
- Tics, **1755–1756**
- Tieck Prize, 1663
- Time, **1756–1758**  
autohistorization and, 142  
deferred action and, 377–381  
historical truth and, 749  
history and, 751  
psychic temporality, 1359–1360, 1757  
*See also* Termination of treatment
- Tinbergen, Nikolaas, 799
- Tisseron, Serge, 846, 1266
- Tissot, Samuel Auguste David, 1026
- Titchener, Edward Bradford, 502, 871, 1822
- To Have or to Be?* (Fromm), 651
- Tom, René, 1739
- Toman, Edward, 308
- Tomasi di Palma di Lampedusa-Wolff Somersee, Alessandra, 347, 879, 1758, **1758–1759**
- Tonic dialogue, 1465–1466
- Topique*, 529, 611, **1759–1760**  
Aulagnier-Spairani and, 130, 807, 1759  
Enriquez-Joly and, 507  
Perrier and, 1251

Volume 1, pp. 1–662; Volume 2, pp. 663–1344; Volume 3, pp. 1345–1892

- Quatrième Groupe and, 529, 807, 1430, 1759
- Topographical point of view, 640, 1049, **1760**
- aggression and, 34
- collective psychology and, 311
- ego psychology and, 486–487
- fixation and, 588
- on humor, 762–763
- ideational representative and, 786
- identification and, 788
- incompleteness and, 805
- lack of differentiation and, 932–933
- mania and, 1006
- modern conflict theory and, 1065, 1066
- negation and, 1123
- neuroses and, 1138
- Other and, 1212–1213
- perception-consciousness system and, 1248
- preconscious and, 1300
- primary/secondary processes and, 1318–1319
- psychic apparatus and, 1351
- psychic energy and, 1355
- puberty and, 1421
- reality principle and, 1450
- regression and, 1460
- repression and, 1483
- resistance and, 1488
- rituals and, 1504
- seduction theory and, 670
- taboo and, 1724
- See also* Metapsychology; Structural theory
- Topology, **1760–1764**, 1814
- Topology and Time* (Lacan), 931
- Torasi, Lydia, 1155
- Törngren, Per Henrik, 1698
- Torok, Maria, **1764–1765**
- Abraham, Nicolas and, 6, 1764–1765
- Cahiers Confrontation, Les* and, 241
- Confrontation* and, 327
- on cultural transmission, 358
- feminist views of psychoanalysis and, 576, 578
- on intergenerational phenomena, 846
- on internal objects, 850
- on introjection, 870
- on object loss, 994
- on phantom, 1265–1266
- on secrets, 1560
- on wish for a baby, 1864
- Toronto Psychoanalytic Society, 1622
- Torres, A., 1833
- Torrubia, Horace, 1766
- Torus, 1762–1763, 1814
- Tosquelles, François, **1765–1766**
- Tostain, René, 129
- Totem and Taboo* (Freud), **1766–1767**
- on act/action, 9
- on ambivalence, 56
- on animistic thought, 85–86
- anthropology and, 93
- applied psychoanalysis and, 107
- Balint and, 1314
- on castration complex, 251
- on collective psychology, 311
- on contact, 338, 339
- on cultural transmission, 357
- on Darwinism, 366
- definition of psychoanalysis and, 1365
- on developmental processes, 1330
- on estrangement, 524
- on ethics, 526
- on family romance, 549
- on fantasy, 551, 552
- on father, 1452
- on father complex, 557
- Group Psychology and the Analysis of the Ego* and, 712
- on heredity of acquired characters, 736
- on history, 750
- on identification, 787
- Imago* and, 802
- on incest, 804
- on individual, 810
- Jankélévitch and, 887
- Jung and, 639
- “Little Arpåd” case and, 988
- on magical thinking, 1000
- on melancholia, 1083
- on myth of origins, 1091–1092, 1238, 1321–1322, 1438
- on mythology, 1096–1097
- on narcissism, 1105
- on Oedipus complex, 1184
- on omnipotence of thoughts, 1189
- on organic repression, 1207, 1208
- on otherness, 1214
- on parenthood, 1237
- on parricide, 1078
- philosophy and, 1270
- on phylogenesis, 1277–1278
- on politics, 1293
- on primitive, 1319
- on primitive horde, 1320, 1321
- on prohibition, 1332
- on projection, 1335
- publication of, 640, 732
- Putnam and, 1425
- on religion, 1855
- on rituals, 1503, 1504
- sexuation and, 1595
- sociology and, 1632
- on suicide, 1687
- on superego, 471, 1690
- on taboo, 1723–1724
- on thought, 1746
- on totemism, 1769
- on transcultural perspectives, 1775
- on transgression, 1792
- on uncanny, 1815
- Totemism, **1768–1769**
- collective psychology and, 311
- dipsomania and, 413
- double and, 434
- “Little Arpåd” case and, 988, 1768
- mythology and, 1097
- oral-sadistic stage and, 1203
- substitute formations and, 1680
- taboo and, 1723
- Touching. *See* Contact
- Toulouse, Édouard, 1350, 1528, 1537
- Tourette, Gilles de la, 331
- Tourneur, Zacharie, 104
- Toussenel, Alphonse, 1437
- Toward a Theory of Schizophrenia* (Bateson, Jackson, Haley, and Weakland), 433
- Toward the African Revolution* (Fanon), 550
- Toward the Preparation of a Metapsychology* (Freud), 732
- Toxological theory, 42
- Trace, 1605
- Tragheit*. *See* Inertia principle
- Traill, Lorna, 131
- Training analysis, 1430, 1457, 1627, **1769–1771**, 1771–1772
- “Training Analysis and Control Analysis” (Kovács-Prosznitz), 923
- Training of the psychoanalyst, **1771–1774**
- American Psychoanalytic Association and, 61–62
- Association psychanalytique de France and, 123
- Balint groups, 147–148, 149, 700, 1003, 1442
- British Psycho-Analytical Society and, 228–229
- Canadian psychoanalysis and, 243

## INDEX

Volume 1, pp. 1–662; Volume 2, pp. 663–1344; Volume 3, pp. 1345–1892

- European institutes, 61  
 fourth analysis, 602–604, 611  
 Hungarian School and, 146–147, 148, 764, 766, 923  
 infant observation and, 818  
 International Psychoanalytical Association and, 855–856, 857  
 Kovács-Prosznitz on, 923  
 Lacan and, 613, 1430  
 psychoanalytic filiations and, 1372–1374  
 psychosis/neurosis distinction and, 1415  
 Quatrième Groupe and, 1430–1431  
 Real and, 1453  
 Ross on, 1516  
 second fundamental rule and, 655  
 supervised (control) analysis, 602–604, 1692–1693  
 training analysis, 1430, 1457, 1627, 1769–1772  
 “wild analysis” and, 1860–1861  
*See also* Lay analysis; Pass, the; Training analysis
- Traité de psychiatrie de l'enfant et de l'adolescent* (Lebovici, Diatkine, and Soulé), 408, 532, 539–540, 744, 955  
*Traité de psychopathologie* (Minkowski), 1057  
*Traité des hallucinations* (Ey), 540  
 “Traitement psychanalytique du caractère, Le” (Ferenczi), 273  
*Trajectoire du rêve*, 1695  
 Tran Duc Thao, 53  
 Trance, 160, **1774**  
 Trans, 245  
 Transactional analysis, 568  
*Transcendence of the Ego, The* (Sartre), 1534–1535  
 Transcendent function, 14, 317  
 “Transcendent Function, The” (Jung), 14  
 Transcultural perspectives, **1774–1776**, 1870  
 “Transfer paradoxal” (Anzieu), 1226  
 Transference, 1384, **1776–1778**  
 abstinence and, 8, 1786  
 acting out and, 10, 11, 657, 1786  
 Aichhorn on, 36  
 alchemy and, 40  
 allergies and, 48  
 alter ego and, 52  
 amplification and, 68  
 analysand and, 75  
 analytical psychology on, 79, 80, **1779–1780**  
 “Anna O.” case and, 88, 89, 225, 1787  
 Anzieu on, 104  
 archaic mother and, 113  
 Arlow on, 120  
 arrogance and, 121  
 attachment and, 126  
 autism and, 137  
 Balint groups on, 147  
 belief and, 159  
 Bigras on, 178–179  
 bipolar self and, 185  
 Breton on, 224  
 cathartic method and, 258  
 change and, 267  
 child analysis and, 279, 1386–1387, 1732, 1733, 1782–1784, **1782–1784**  
 Claude on, 305  
 complexes and, 321  
 conscious processes and, 333  
 container-contained and, 340  
 cruelty and, 354  
 dead mother complex and, 368  
 death instinct and, 371  
 dependence and, 392  
 depression and, 368, 1780–1782  
*Development of Psycho-Analysis* on, 407  
 displacement and, 422–423  
 dreams and, 439  
 ethics and, 525  
 femininity and, 573  
 Freud’s self-analysis and, 425  
 fundamental rule and, 656, 657  
 Gattel and, 667  
 gifts and, 682, 683  
 group psychotherapies and, 714  
 Guex on, 715  
 Hirschfeld, Elfriede and, 747  
 hypochondria and, 770  
 idealizing, 542, 785, 1116, 1580  
 identification and, 790  
 indications/contraindications for psychoanalysis and, 809  
 interpretation and, 862, 863  
 introjection and, 871  
 invariant and, 872  
 Kemper, Werner Walther on, 910  
 latent/manifest dream elements and, 1008  
 lateral, 422–423, 1777  
 love and, 77, 513  
 mirror transference, 52, 1059–1060, 1115, 1580  
 mother and, 577  
 mutative interpretation and, 1089–1090  
 Nacht on, 1103  
 narcissistic, 785, 920, 1115–1116, 1574, 1576, 1810  
 need for causality and, 1119  
 negative, 77, 1127–1128, 1777, 1781–1782  
 object relations theory and, 1177  
 oceanic feeling and, 1182  
 pairs of opposites and, 1220  
 paradox and, 1226  
 paranormal phenomena and, 1181  
 patient physical position and, 541  
 primary love and, 1315  
 projective identification and, 1338, 1339  
 psychoanalytic semiology and, 1380  
 psychoses and, 487, 568, 1405, 1419  
 psychotherapy and, 1412  
 psychotic, 1419  
 “Rat Man” case and, 821  
 remembering and, 1468  
 repetition and, 1469  
 resistance and, 1488, 1777  
 resolution of, 1490–1491  
 Schlumberger on, 1542  
 Schur and, 628  
 Searles on, 310  
 sexuality and, 1594  
 on sexuation, 1595  
 Silberer on, 1608  
 subject of the unconscious and, 1676  
 termination of treatment and, 77  
 transference relationship and, 1788–1789  
 translation and, 1797  
 twinship, 52, 1060, 1115–1116, 1580, 1810  
 unconscious fantasies and, 120  
 violence and, 178–179  
*See also* Transference neuroses  
 “Transference” (Freud), 95  
*Transference* (Lacan), 554, 1201  
*Transference and Countertransference* (Racker), **1778–1779**  
*Transference and Its Context* (Stone), 1661  
 Transference depression, 368, **1780–1781**, 1781–1782  
 Transference hatred, **1781–1782**  
 Transference love, 77, 513, **1785–1786**  
 Transference neuroses, 1140, 1385, 1777, **1786–1787**  
 actual vs. defense neuroses and, 20, 1139  
 change and, 268  
 child analysis and, 1732  
 dualism and, 448  
 ethics and, 525  
 Nacht on, 1103  
 patient physical position and, 542

Volume 1, pp. 1–662; Volume 2, pp. 663–1344; Volume 3, pp. 1345–1892

- phobias and, 1274  
 repetition and, 1473  
 therapeutic alliance and, 1741  
 Transference of creativity, **1787–1788**  
 Transference psychoses, 1514  
 Transference relationship, **1788–1790**  
*Transfert paradoxal* (Anzieu), 434  
*Transformation and Symbolism of the Libido* (Jung), 968  
 Transformational object, 30, 1170–1171  
 Transformations, **1790–1791**  
   hallucinosis and, 722, 723  
   ideational representative and, 786  
   invariant and, 871–872  
*Transformations: Change from Learning to Growth* (Bion), 704, 871, 995, 1030, 1791, 1833  
 Transgenerational phenomena  
   Abraham, Nicolas on, 7  
   Benedek on, 160  
   counter-Oedipus and, 349  
   cultural transmission and, 357–358  
   family romance and, 548  
   identification and, 789–790  
   identification fantasies and, 791  
   intergenerational phenomena and, 845, 846  
   ontogenesis and, 1197  
   prematurity and, 1305  
 Transgression, 524, 657, 1037, **1791–1793**  
 Transience, 1195–1196  
 Transitional analysis, 1614  
 Transitional objects. *See* Transitional phenomena  
 “Transitional objects and the process of individuation” (Gaddini and Gaddini), 663  
 “Transitional Objects and Transitional Phenomena” (Winnicott), 1793, 1795, 1796  
 Transitional phenomena, 698, **1793–1797**, 1862  
   addiction and, 23  
   Blackett-Milner on, 190  
   children’s play and, 283  
   infantile omnipotence and, 823  
   object *a* and, 1173  
   object and, 1169  
   primary object and, 1317  
   psychosomatic limit and, 1410  
   reparation and, 1472  
   Shakespeare and, 1598  
   splitting of the object and, 1642  
   Transitional space. *See* Transitional phenomena  
   Translation, 379, 862, **1797–1798**  
   Transmission of the inert, 1560  
   Transmuting internalization, **1798**  
   Transsexualism, 669, 1578, 1660, **1798–1800**  
   Transvestism, 1546, 1799  
   “Tratamiento psicoanalítico de un caso de neurosis compulsiva” (Psychoanalytic treatment of a case of compulsive neurosis) (A. Z.), 1  
*Tratato mayor del psicoanálisis de los sueños* (Garma), 666  
*Trattato di psicoanalisi* (Musatti), 1088, **1800**  
*Traum und seine Bedeutung, Die* (Kemper), 910  
 Trauma, **1800–1802**  
   Abraham, Nicolas on, 7  
   amnesia and, 64  
   choice of neurosis and, 287–288  
   complemental series and, 318  
   Control-Mastery Theory and, 1532  
   cultural transmission and, 358  
   deferred action and, 379–381  
   family and, 547–548  
   Ferenczi on, 328–329, 581  
   fixation and, 588  
   fright and, 648  
   helplessness and, 734  
   paranoia and, 1227  
   pleasure in thinking and, 1289  
   protective shield and, 1341  
   *Psychoanalytic Study of the Child, The* on, 1382  
   real, 318, 1455  
   Real and, 1454  
   termination of treatment and, 76  
   war neuroses and, 1848  
   *See also* Birth trauma; Seduction theory  
   *Trauma of Birth, The* (Rank), 833, 861, 1445, 1643, 1729, 1738, **1802–1803**  
 Traumatic neuroses, **1803–1804**  
   fixation and, 588  
   fright and, 563  
   Kardiner on, 907  
   reminiscences and, 1471  
   repetition compulsion and, 1474  
*Travail du deuil, Le* (Lagache), 936  
 Treatment. *See* Child analysis; Children, treatment of; Psychoanalytic treatment  
 Treatment duration. *See* Termination of treatment  
 Tremblais-Dupré, Thérèse, Mâle and, 1004  
*Trends in Psycho-Analysis* (Brierley), 226  
*Trennung der Liebenden, Die* (Caruso), 249  
 Trevarthen, C., on nonverbal communication, 1153  
 Trial by ordeal, 1686  
 Triandafillidis, Alexandra, 1688  
 Triangulation. *See* Oedipus complex  
*Tribute to Freud* (H.D.), 429  
*Tribute to the World* (H.D.), 431  
*TRIEB*, 217  
*Trieben*. *See* Drives  
*Triebpathologie* (Szondi), 1722  
*Triebpathologie II* (Szondi), 1722  
*Triebtheorie*. *See* Instinct theory  
 Trilling, Diana, 1503  
 Trilling, Lionel, 1825  
*Trimestre psychanalytique, Le*, 1084  
*Tristes Tropiques* (Lévi-Strauss), 93  
*Triumph of the Therapeutic, The* (Reiff), 1826  
 Troisier, H., 1500  
 Trombetta, Carlo, 302  
 Tronick, Edward, 1382  
 Trotsky, Leon, 1519  
 Trousseau, Armand, 106, 120  
*Truants from Life* (Bettelheim), 173  
 True self, 1581–1582  
 Trümpell, Adolf, 1671  
 Truth, 65, 140, **1804–1806**  
   *See also* Historical truth  
 Tube-ego, **1806**  
 Tuckett, David, 853  
 Tuke, Hack, 769  
 Tunisian psychoanalysis, 1155–1156  
 Tuovinen, Matti, 584  
 Turner, Julia, 684, 685  
 Turning around, **1806–1808**  
   reversal into the opposite and, 1494, 1495, 1807–1808  
 Turquet, Pierre M., 24, 692, 816  
 Tustin, Frances, **1808–1810**  
   on autism, 137, 138, 139, 420, 1809  
   on birth trauma, 1803  
   on black holes, 189–190, 218  
   on developmental processes, 1330  
   on dismantling, 420  
   on helplessness, 734  
   on infantile psychosis, 825  
*Journal de la psychanalyse de l’enfant* and, 896  
   on lack of differentiation, 932  
   on negative hallucination, 1125  
   on pregenital stage, 1186



## INDEX

Volume 1, pp. 1–662; Volume 2, pp. 663–1344; Volume 3, pp. 1345–1892

- on self-mutilation, 1573  
 on skin, 815  
 on splitting of the object, 1642  
 structural theories and, 1666  
 on sucking, 1682  
 on tube-ego, 1806  
*Twelfth Night* (Shakespeare), 1598  
 “Twenty-four Hours in the Life of a Woman” (Zweig), 432  
 Twins, double and, 435  
*Twins: A Study of Three Pairs of Identical Twins* (Burlingham), 802  
 Twinship transference, 52, 1060, 1115–1116, 1580, **1810**  
 “Two Analyses of Mr. Z, The” (Kohut), 920, 1107  
 “Two Lies Told by Children” (Freud), 746, 971  
 “Two Principles of Mental Functioning, The”. See “Formulations on the Two Principles of Mental Functioning”  
 Tyler, Edward Burnett, 85, 1000  
 “Types of Onset of Neurosis” (Freud), 653  
 Typical dreams, 185–186, 344–345, 441, 533, 1103, **1810–1811**  
 Tyson, Alan, 753, 1521, 1654  
 Tyson, Phyllis, 897  
 Tyson, Robert, 860  
 Tzavaras, Athanase, 701  
 Tzavaras, Hélène, 701
- U**  
 “Über Coitus im Kindesalter” (Stekel), 1657  
 “Über das Unbewusste und seine Inhalte” (Jung), 313  
*Über das Wesen der Hypnose* (Schilder), 1538  
 “Über den Gegensinn der Urworte” (Abel), 4  
 “Über die Psychogenese von Organstörungen und ihre psychoanalytische Behandlung” (Simmel), 1612  
 “Über einen Typus der Pseudoaffektivität (‘Als ob’)” (Deutsch), 972  
 “Über latent, negative Übertragung” (Sterba), 1659  
*Über psychopathische Minderwertigkeiten* (Gross), 707–708  
 “Überlegungen zum Begriff der Verdrängung” (Laforgue), 1554  
*Übersetzung*. See Translation  
 Uchoa, Darcy M., 566  
 Ulcerative colitis, **1813–1814**  
 Ulriksen de Viñar, Maren, 1829  
*Ulysses* (Joyce), 986  
 Unary trait, 1761, **1814–1815**  
 Unbinding. See Binding/unbinding of the instincts  
 Uncanny, the  
 certainty and, 265  
 double and, 429, 434, 1815  
 femininity and, 573  
 German romanticism and, 673  
 maternal and, 1028  
 premonitory dreams and, 1305  
 psychogenic blindness and, 1393  
 racism/anti-Semitism and, 1437, 1438  
 “‘Uncanny,’ The” (Freud), 341, 351, **1815–1816**  
 on depersonalization, 393  
 on double, 429, 434, 1106  
 on estrangement, 524  
 on fascination, 556  
 on narcissism, 1106  
 on racism/anti-Semitism, 1438  
 on repetition, 1473  
 on Schiller, 1539  
 on secrets, 1560  
 Uncertainty, doubt and, 435  
*Unconscious Today: Essays in Honor of Max Schur, The*, 1548  
 Unconscious, symptoms and, 1715  
 Unconscious, derivatives of. See Repressed, derivatives of the  
 Unconscious, the, **1818–1820**  
 active imagination and, 14  
 amnesia and, 64, 65  
 analytical psychology on, 79, 80  
 animistic thought and, 86  
 breastfeeding and, 221–222  
 character and, 272  
 collective unconscious and, 313  
 Colloque sur l’inconscient and, 314–315  
 compensation and, 317  
 complexes and, 320  
 conflict and, 326  
 contact-barrier and, 339–340  
 contradiction and, 341  
 counter-transference and, 350  
 defenses and, 374  
 determinism and, 401  
 directed daydreams and, 414  
 double and, 434  
 dreams and, 438–439  
 ego and, 469  
*Ego and the Id, The* on, 470  
 ego psychology and, 486  
 extroversion/introversion and, 538  
 female sexuality and, 571  
 feminist views of psychoanalysis and, 577  
 forgetting and, 596, 597  
 formations of, **597–598**  
 guilt and, 717–718, 781  
 id and, 778  
 ideational representative and, 786  
 individuation and, 812  
 as infinite sets, 1816  
 intergenerational phenomena and, 846  
 Jung on, 1400  
 Kantianism and, 905  
 L and R schemas and, 927  
 latent dream thoughts and, 947  
 logic and, 989  
 Matte-Blanco on, 1033  
 melancholia and, 21  
 memory and, 1040, 1041, 1063  
 multidisciplinary interactions and, 109  
 myth of origins and, 1092  
 Nazi Germany and, 1023  
 Nodet on, 1152–1153  
 object relations theory and, 1176  
 partial drives and, 1241  
 perversion and, 1255  
 philosophy and, 1271  
 politics and, 1293  
 preconscious and, 1300  
 prereflective, 1307  
 primary/secondary processes and, 1318  
 projection and, 1337  
 psyche and, 1348, 1349  
 psychic reality and, 1356–1357  
 purpose of psychoanalysis and, 20  
 remembering and, 1467–1468  
 repression and, 1478, 1482, 1485, 1487  
 Searles on, 310  
 seduction theory and, 669, 670  
 sexualization and, 399  
 subject of, 1675–1676  
 taboo and, 1724  
 time and, 1757  
 transgression and, 1792  
 unvalidated, 1827  
 See also Repression  
 “Unconscious, The” (Freud), **1820–1821**  
 action-presentations and, 12, 13  
 on anticathexes, 94  
 on binding/unbinding, 179  
 on consciousness, 333  
 on derivatives of the repressed, 1481  
 on free energy/bound energy, 617

Volume 1, pp. 1–662; Volume 2, pp. 663–1344; Volume 3, pp. 1345–1892

- on hypercathexis, 767  
 on ideational representation, 785, 786  
 on language, 943  
 Matte-Blanco on, 1033  
 on paraphrenia, 1234  
 on preconscious, 1300  
 on primary/secondary processes, 1318  
 on psychic representative, 1358  
 on representation, 781  
 on repression, 1484  
 on substitute formations, 1681  
 suppression and, 1694  
 on thing-presentations, 1741–1742  
*Unconscious as Infinite Sets, The: An Essay in Bi-logic* (Matte-Blanco), 284, 1033, **1816**  
 Unconscious concepts, **1817**  
 Unconscious fantasies, 115, 119–120, 1312, **1817–1818**  
*Unconscious Motives of War, The* (Strachey), 1664  
*Understanding Human Nature* (Adler), 25, 1019  
*Understanding Your Family* (Grinstein and Sterba), 1658  
 Undoing, 1180, 1821–1822, **1821–1822**  
*Unebévue, L'*, 1084  
 Unfulfilled mourning, 1560  
*Ungeschehenmachten*. See Undoing  
*Unheimlichkeit*. See Uncanny, the  
 Union of Psychoanalysts and Psychologists, 1034  
 Unitarianism, 1425  
 United Kingdom Council for Psychotherapy, 698  
*Univers contestationnaire, L'* (Grunberger and Chasseguet-Smirgel), 612  
 Universal quantifier, 1595  
 University of Vienna, 1659, **1837–1838**  
 Unpleasure, 729, 1066, 1315, **1826–1827**  
 Unpleasure principle. See Pleasure principle  
 Unthinkable anxiety, 90, 1320  
 Unvalidated unconscious, **1827**  
*Uomo Delinquente, L'* (Lombroso), 353  
 Urbantschitsch, Rudolf von, **1827–1828**, 1869  
 Urethral eroticism, **516–517**, 1679  
 Urges, 323  
 Urinary retention, 66  
 Urination, 66, 507–508, 1347, 1367  
*Urphnomen*, 687  
 Urribarri, Rodolfo, 946  
 Urtubey, Luisa de, 1610  
 Uruguay Psychoanalytic Association, 55, 1829  
 Uruguayan psychoanalysis, 55, **1828–1830**  
*Urverdrängung*. See Primal repression  
 U.S. psychoanalysis, **1822–1826**  
 Brunswick and, 232  
 cinema and, 292  
 Filipino psychoanalysis and, 1268  
 Frink and, 648, 649  
 Japanese psychoanalysis and, 887  
 Jones and, 696  
 Klein and, 992–993, 1888  
 Kohut and, 920  
 Los Angeles Psychoanalytic Society/Institute and, 992–993  
 Menninger Clinic and, 1044–1045  
 New York Psychoanalytic Institute/Society and, 1147  
*Psychoanalytic Quarterly, The* and, 1377–1378  
 Second World War and, 1558  
 Washington Psychoanalytic Society and, 1849–1851  
 See also American Psychoanalytic Association; Chicago Psychoanalytic Institute  
 “Use of an Object and Relating Through Identifications, The” (Winnicott), 1796  
*Uses of Enchantment, The: The Meaning and Importance of Fairy Tales* (Bettelheim), 173, 986  
*Utilitarianism* (Mill), 1290  
 Utraquism, 66  
 Uznadze, Dmitri, 1519
- V**  
 Vacher de Lapouge, Georges, 1437  
 Vacillation, 1605  
 Vacková, B., 361  
 Vadilieva, Nima, 1520  
 “Vagina dentata” fantasy, **1831**  
 Vaginal eroticism, 66, 574  
 Valabrega, Jean-Paul, 77  
 Aulagnier-Spairani and, 129  
 École freudienne de Paris and, 457, 458, 611  
 on excitation, 534  
 on fourth analysis, 603  
 French psychoanalysis and, 613  
 on incompleteness, 805  
*Inconscient, L'* and, 807  
 on latent dream thoughts, 947  
 on mythology, 1099  
 on pass, 1243, 1251  
 on psychosomatics, 610, 1409  
 Quatrième Groupe and, 611, 807, 1429–1430, 1645  
 on somatic compliance, 1635  
*Topique* and, 1759  
 on working-through, 1880  
 Valdizán, Hermilio, 1, 384, 1253, 1496, 1497, **1831–1832**  
 Valéry, Paul, 223, 953  
 “Value of Psychoanalysis, The” (Porto-Carrero), 1295  
 Values, 159  
 Vampirism, 138, 220  
 Van Bockstaele, Jacques, 1632  
 Van Bockstaele, Maria, 1632  
 Van der Heide, Carel, 1610  
 Van der Leeuw, Pieter Jacob, 857, **958**, 1133  
 Van des Walls, H. G., 330  
 Van Eeden, Frederik, 1685  
 Van Emden, Jan Egbert Gustaaf, **498–499**, 1132, 1133  
 Van Merlen, Thérèse Jacobs, 157  
 Van Ophuijsen, Johan H. W., **1200**  
 Dutch psychoanalysis and, 1133, 1200  
 Flournoy, Henri and, 591  
 Secret Committee and, 1562  
 Swiss psychoanalysis and, 1549, 1700, 1702  
 Vanggaard, Thorkil, 391  
 Varendonck, Julien, 157  
 Varias, Rudolfo, 1268  
 Vaysse, Jean-Marie, 1271  
*Vel* (forced choice), 44  
 Veldman, Franz, 339  
 Venezuelan psychoanalysis, **1832–1833**  
*Verbrecher und seine Richter, Der* (The Criminal, the judge, and the Public: A Psychological Analysis) (Alexander & Staub), 43  
*Verdichtung*. See Condensation  
 Verdiglione, Armando, 880  
*Verdrängung*. See Repression  
 “Verdrängung und Skotomisation” (Laforgue), 1554  
 Verein für Freie Psychoanalytische Forschung, 25, 1857  
 Verein für Individualpsychologie, 25, 1857  
 Vergote, Antoine, 158  
*Verleugnung*. See Denial; Disavowal  
 Vermorel, Henri, 1499  
*Verneinung*. See Negation  
*Versagung*. See Frustration; Privation  
*Verschiebung*. See Displacement  
 Vertex, **1833–1834**  
 Vertigo, 1365  
*Verwahrloste Jugend* (Wayward Youth) (Aichhorn), 2, 36

## INDEX

Volume 1, pp. 1–662; Volume 2, pp. 663–1344; Volume 3, pp. 1345–1892

- Verwerfung*. See Foreclosure
- Veszy-Wagner, Lilla, 680
- Viderman, Serge, **1834–1836**  
on anticipatory ideas, 96  
*Cahiers Confrontation, Les* and, 241  
on change, 268  
Collège des Psychanalystes and, 314, 1835  
*Confrontation* and, 327, 1835  
on constructions, 335, 337  
on developmental processes, 1330  
Enriquez-Joly and, 506  
on history, 751  
*Inconscient, L'* and, 807, 1835  
on internal/external reality, 848  
on memory, 1043  
*Revue française de psychanalyse* and, 1499  
Société psychanalytique de Paris and, 1626, 1627, 1628, 1835  
on truth, 1805  
*Vie et la Mort des instincts, La* (Hesnard), 742  
“Vie mentale, La” (Lacan), 459  
Vienna, University of, **1837–1838**  
Vienna Ambulatorium, 568, **958–959**  
Vienna General Hospital, **1837**  
Vienna Psychoanalytic Association, 36  
Vienna Psychoanalytic Society. See Wiener psychoanalytische Vereinigung  
Vienna Seminar on Sexology, 176  
Vienna Working Group on Depth Psychology. See Wiener Arbeitskreise für Tiefenpsychologie  
Vietnam War, 208  
Vietnamese psychoanalysis, 78  
Vikár, György, 766  
Villar, A., 315  
Viñar, Marcelo, 567, 1829  
Vincent, Jean-Didier, 183  
Vindreau, Christine, 234  
Violence  
vs. aggression, 33–34  
Bigras on, 178–179  
envy and, 509  
instinct of, 1838–1839  
Klein on, 509  
*Violence et la vie, La* (Bergeret), 1359  
*Violence fondamentale, La* (Bergeret), 1839  
Violence instinct, **1838–1839**  
*Violence of Interpretation, The: From Pictogram to Statement* (Castoriadis-Aulagnier), 130, 613, **1839–1840**  
on ideational representation, 785  
on identificatory project, 793  
on *infans* stage, 813  
on pictogram, 1286, 1287, 1312  
on psychotic potential, 1418  
on sense/nonsense, 1584  
Virág, Teréz, 766  
Virginal anxiety, 1136  
Virginity, 342–343, 1725  
Virilio, Paul, 241  
Vischer, Robert, 502  
Vischer, Theodor, 891  
Visual, the, **1840–1841**  
Visual arts, **985, 1841–1842**  
Anzieu and, 105  
applied psychoanalysis and, 107–108  
Arlow on, 119  
Blackett-Milner and, 190  
illusion and, 797  
“Moses of Michelangelo, The”, 985, 1079, 1842  
Sigmund Freud Society and, 136  
*Weltanschauung* and, 1855  
Wolfenstein on, 1870  
*Vital Balance, The* (Menninger), 1045  
Vital fluids, 41  
Vlad, Constantin, 1511  
*Vocabulaire de la psychanalyse* (Laplanche and Pontalis). See *Language of Psychoanalysis, The*  
Vocabulary, 3–4  
Vogt, O., 678  
Vogt, Ragnar, 1156  
Voice, 1173  
Voigt, Diana, 1391  
Voitel, Karl H., 675  
Volney, Constantin- François, 795  
Von Freund Toszeghy, Anton, **645**  
Freud and, 174, 586, 639, 645  
Hungarian psychoanalysis and, 765  
Internationaler Psychoanalytischer Verlag and, 861  
Von Lieben, Anna. See “Cäcilie M.” case  
*Vorlesungen über Physiologie* (Brücke), 231  
*Vorstellung*. See Representation  
*Vorstellungsmechanik*, 82  
Voss, Hans, 1832  
Voyeurism, 17, 1021, 1675, 1807, 1808, **1842–1843**  
Vulpian, Alfred, 106  
Vuoristo, Gunvor, 584  
Vyroubov, Nikolai A., 1411
- W**  
Waal, Nic, 1157, 1158  
Waelder, Robert, **1845–1846**  
Boston Psychoanalytic Society/Institute and, 207  
Czech psychoanalysis and, 361  
on ego functions, 478  
Filipino psychoanalysis and, 1268  
Foulkes and, 601  
*Gesammelte Schriften* and, 680  
Hartmann and, 727  
*Journal of the American Psychoanalytic Association*, 897  
U.S. psychoanalysis and, 1825  
Waelder-Hall, Jenny  
Boston Psychoanalytic Society/Institute and, 207  
on identification with the aggressor, 792  
Lehrinstitut der Wiener psychoanalytischen Vereinigung and, 959  
Washington Psychoanalytic Society and, 1849, 1850, 1851  
Wagner, Richard, 1437  
Wagner-Jauregg, Julius, 1836, **1846**  
Burrow and, 237  
Deutsch-Rosenbach and, 404–405  
Freud, Anna and, 619  
Isakower and, 874  
Lampl-de Groot and, 938  
Landauer and, 940  
Nunberg and, 1165  
photograph of, III:pl.16  
Pöttl and, 1299  
“Rat Man” case and, 1161  
Schilder and, 1538  
Tausk and, 1726  
Wahl, François, 459  
Wahle, Richard, 1836  
*Wahn und Erkenntnis* (Schilder), 1538  
Wakefulness/sleep, **1614–1615**  
Walewska, Katarzyna, 1292  
Walker, Janet, 294  
Wallerstein, Robert, 858, 859, 888, 1412, 1530–1532  
Wallon, Henri  
on act/action, 9  
on early interactions, 451  
Mâle and, 1004  
on mirror stage, 1058, 1107  
on self-image, 1571  
Viderman and, 1835  
Walter, Bruno, **1847**  
Wangh, Martin, 877, 1597  
Wanke, Georg, 674  
Want of being. See Lack of being

Volume 1, pp. 1–662; Volume 2, pp. 663–1344; Volume 3, pp. 1345–1892

- War  
 Bion and, 183  
 civilization and, 299  
 disillusionment and, 1750–1751  
 Fornari on, 598  
 Freud on, 1855–1856  
 Money-Kyrle on, 1070  
*War, Sadism, and Pacifism* (Glover), 684  
*War and Children* (Freud and Burlingham), 960  
 War neuroses, **1848–1849**  
 British psychoanalysis and, 696, 697  
 German psychoanalysis and, 674–675  
 Hungarian psychoanalysis and, 765  
 Israeli psychoanalysis and, 877  
 Kardiner on, 906–907  
 New York Psychoanalytic Institute/Society and, 1147–1148  
 Tavistock Clinic and, 1727  
 Tosquelles and, 1765  
 trauma and, 1801  
 U.S. psychoanalysis and, 61  
 Wagner-Jauregg on, 1846  
*War-shock* (Eder), 460–461  
 Warburg, Otto, 160  
 Warda, Wolfgang, 674  
 Warren, Howard C., 1553  
 Washington Psychoanalytic Society, 1688, **1849–1851**  
 Waterhouse, I., 131  
 Watermann, August, 675, 676, 725, 1133  
 Watterson, Donald, 244  
 Watzlawick, Paul, 433, 980, 1720  
 Weakland, John H., 433  
 Weaning, 1346–1347, 1406, 1594, **1851–1852**  
*See also* Breast; Breastfeeding  
 Weber, Guido, 1545  
 Weber, Max, 159, 660, 708, 1631  
 Weber, Samuel, 241  
 Wednesday Society, 638  
 Berggasse 19, Wien IX and, 162  
 Graf, Max and, 690  
 Heller and, 732  
 Rie and, 1503  
 Rosenthal and, 1515  
 transference and, 667  
 Wiener psychoanalytische Vereinigung and, 1857  
 Wittels and, 1868  
 Weigert-Vowinkel, Edith, 852, 1734  
 Weil, Eva, 1629  
 Weil-Halpern, Françoise, 955  
 Weininger, Otto, 1587–1588, 1704, **1852–1853**  
 Weinschel, Edward M., 169, 858, 1530, 1532  
 Weinstein, S., 1052  
 Weismann, August, 371  
 Weiss, Daniel, 900  
 Weiss, Edoardo, 495, **1853–1854**  
 on death instinct, 372, 1854  
 Federn, Paul and, 568  
 Italian psychoanalysis and, 495, 878, 879, 963, 1508, 1853  
 on libido, 969  
 Musatti and, 1088  
*Opere* and, 1199  
 Perrotti and, 1251, 1854  
*Rivista di psicoanalisi* and, 1508  
 Servadio and, 1586  
 Tomasi and, 1758  
 Weiss, Ilona. *See* “Elisabeth von R.” case  
 Weiss, Joseph, 1532  
 Weiss, Naomi, 877  
 Weissenberg, Siegfried, 504  
 Weissman, Stephen, 1610  
 Weizmann, Chaim, 461  
 Weizsäcker-Hoss, Kate, 1222  
 Welldon, Estela V., 1259  
 Weller, Gertrud, 1085  
*Weltanschauung*, **1854–1855**  
 animistic thought and, 85–86  
 illusion and, 797  
 Kantianism and, 905  
 need for causality and, 1119  
*New Introductory Lectures on Psychoanalysis* on, 1146, 1854  
 Wencelblat, Matilde, 117  
 Wencelblat, Simon, 117  
 Werneck, Luiz L., 215  
 Wernicke, Carl, 106, 212, 707, 1042  
 West Indian psychoanalysis. *See* Martinican psychoanalysis  
 Westphal, Karl Friedrich, 322, 1272, 1273  
 Wetterstrand, Otto, 188  
 Weygandt, Wilhelm, 824  
*When Spring Comes* (Khan), 913  
 Whitaker, Carl, 1445  
 White, William Alanson, 889, 1379, 1540, 1688, 1745, 1849  
 Whiting, Carlos D’Andurain, 284, 566  
 Whole-object love, 218  
 “Why War?” (Freud) (Letter to Einstein), 372, 447, 641, 879, 1097, **1855–1857**  
 “Widening scope of indications for psychoanalysis, The” (Stone), 1661  
*Widerspruchlosigkeit*. *See* Contradiction  
 Widlöcher, Daniel  
 on act/action, 9  
 on action-presentations, 13  
 on borderline conditions, 202  
 on change, 267, 268  
 on economic point of view, 459  
 on emotions, 501  
 French psychoanalysis and, 613  
 French psychoanalytic establishment split (1964) and, 123  
 on internal/external reality, 848  
 International Psychoanalytical Association and, 613  
 on latent dream thoughts, 947  
*Psychanalyse, La* and, 1348  
 on psychic representative, 1358  
 on psychic structure, 1359  
*Revue Internationale de psychopathologie* and, 569  
 Smirnoff and, 1617  
 Société française de psychanalyse and, 1619  
 Société psychanalytique de Paris and, 1627, 1630  
 Venezuelan psychoanalysis and, 1833  
 Wiene, R., 292  
 Wiener Arbeitskreise für Psychanalyse, 135–136  
 Wiener Arbeitskreise für Tiefenpsychologie, 134, 135, 248, 852  
*See also* Wiener Arbeitskreise für Psychanalyse  
 Wiener Cottage Sanatorium, 1828, 1869  
 Wiener-Lehrman, Lynne, 960  
 Wiener psychoanalytische Vereinigung (WPV), **1857–1859**  
 Andreas-Salomé and, 83  
 Austrian psychoanalysis and, 132–133, 134  
 Bibring-Lehner and, 176–177  
 Caruso and, 248  
 Croatian psychoanalysis and, 1884  
 Federn, Paul and, 568  
 Fenichel and, 579  
 Freud, Anna and, 619  
 Hartmann and, 727  
 Hilferding-Hönigsberg and, 746  
 Hug-Hellmuth and, 761  
 International Psychoanalytical Association and, 854  
 Isakower and, 874  
 Jekels and, 888  
 Laforgue and, 933  
 Lehrinstitut and, 959

## INDEX

Volume 1, pp. 1–662; Volume 2, pp. 663–1344; Volume 3, pp. 1345–1892

- minutes of, 1057–1058  
Pötzl and, 1299  
Rank and, 1444, 1857  
Reik and, 1462–1463  
Rie and, 1503  
Sadger and, 1525  
Schilder and, 1538  
Schur and, 1548, 1858  
Silberer and, 1608  
Sokolnicka-Kutner and, 1633  
Spitz and, 1641  
Stekel and, 1657  
Sterba and, 1659  
Sterba-Radanowicz-Hartmann, Editha and, 1658  
Storfer and, 1662  
supervised analysis and, 1692  
Swedish psychoanalysis and, 1698  
Urbantschitsch and, 1828  
Vienna Ambulatorium and, 958–959  
Waelder and, 1845  
Winterstein and, 1858, 1863  
Wittels and, 1869  
Wulff and, 1881  
Wilbern, D., 1597  
Wilbur, George B., 60, 1859, **1859–1860**  
“Wild analysis”  
AÄGP and, 49  
abstinence and, 8  
Berliner Psychoanalytisches Institut and, 165  
International Psychoanalytical Association and, 639, 855  
Porto-Carrero and, 1295  
“‘Wild’ Psycho-Analysis” (Freud), 61, 855, **1860–1861**  
Wilde, Oscar, 429  
Wilgowicz, Pérel, 846, 1439, 1629  
Wilhelm, Richard, 902, 1720  
William Alanson White Institute, 1688  
William Alanson White Psychoanalytic Society, 852, 1746, 1850  
William of Ockham, 1270  
Williams, Frankwood, 1377  
Williams, Paul, 853  
Willis, Thomas, 1414  
Wilson, C. Philip, 1728  
Wilson, Paul, 1497, 1832  
Wilson, Philip C., 48  
Wilson, Woodrow, 234, 235, 311, 750, 1743–1745  
Windholz, Emanuel, 1529  
Windholz, Eugen, 360, 361, 1212  
Winer, Jerome, 279  
Winicott, Donald W., 1557  
Winn, Roy Coupland, 130, 131  
Winnicott, Donald Woods, **1861–1863**  
on abandonment, 2, 3  
on addiction, 23  
on adolescence, 26  
American Psychoanalytic Association and, 992  
Anzieu and, 104  
on autism, 136  
Bettelheim and, 503  
Bigras and, 178  
Blackett-Milner and, 190, 191  
Brazilian psychoanalysis and, 217  
on breakdown, 218, 1420  
on breastfeeding, 221  
British psychoanalysis and, 697  
on bulimia, 233  
on capacity to be alone, 246  
on castration complex, 254  
on change, 268  
child analysis and, 280, 698, 1731–1732, 1733  
on childhood, 280  
on children’s play, 283  
Chodorow and, 577  
on collective unconscious, 313  
on compulsion, 323  
on consciousness, 334  
Controversial Discussions and, 697  
on creativity, 351, 352  
on cruelty, 355  
on deferred action, 380  
definition of psychoanalysis and, 1363  
on demand, 388  
on dependence, 392  
deprivation and, 397  
*Development of Psycho-Analysis* and, 407  
on developmental processes, 1330  
on disintegration anxieties, 418  
on false self, 72, 122, 138, 546–547, 850, 972, 1579, 1580, 1581–1582  
on family, 548  
family therapy and, 1372  
on father, 1346  
feminist views of psychoanalysis and, 577  
Finnish psychoanalysis and, 584  
on *Fort-da* game, 600  
on frame of psychoanalytic treatment, 606  
Gaddini and, 663  
on gaze, 990  
on good-enough mother, 688  
on hallucinatory wish-fulfillment, 1867  
on handling, 724–725, 843  
on hatred, 729  
Hellman Noach and, 733  
on holding, 369, 607, 754, 843, 1582  
on id, 779  
on illusion, 797–798  
on *infans* stage, 812–813  
on infant development, 814, 815  
on infant observation, 817  
on infantile omnipotence, 823  
on infantile psychosis, 825, 826  
on integration, 843–844  
on intergenerational phenomena, 846  
on internal/external reality, 848  
on internal objects, 849, 850  
on intersubjective/intrasubjective dichotomy, 867  
Israeli psychoanalysis and, 878  
Italian psychoanalysis and, 879  
on jokes, 890  
Khan and, 913  
Klein and, 510  
on lack of differentiation, 932  
Lainé and, 937  
Laing and, 937  
Lampl-de Groot and, 938  
Lebovici and, 955  
on maternal, 1028  
on maternal care, 1029  
on maternity, 1298  
on maturation, 1034  
on mutual analysis, 1090  
on narcissism, 1107  
on narcissistic withdrawal, 1116  
on negative therapeutic reaction, 1126–1127  
*Nouvelle Revue de psychanalyse* and, 1163  
on object, 1169, 1170  
on object *a*, 1173  
object relations theory and, 1176, 1862  
on omnipotence of thoughts, 1189  
photograph of, III:pl.18  
on pictogram, 1287  
on pleasure principle, 1291  
on pregenital stage, 1186  
on primary identification, 1314  
on primary object, 1317  
on primitive agony, 1320  
on projection, 1336  
on protective shield, 1340, 1342

Volume 1, pp. 1–662; Volume 2, pp. 663–1344; Volume 3, pp. 1345–1892

- on psychosomatic limit, 1410  
 on puberty, 1420  
 on puerperal psychoses, 1422  
 Racamier and, 1436  
 on reality testing, 1451  
 on regression, 1460, 1709, 1862  
 on reparation, 1472  
 on representation, 782  
 Riviere-Hodgson Verrall and, 1507, 1861  
 Rycroft and, 1521  
 Schilder and, 1538  
 Sechehayé and, 1557  
 on secrets, 1561  
 on self, 1567  
 on self-consciousness, 1569  
 on self-image, 1571–1572  
 on sexuality, 1594  
 on Shakespeare, 1598  
 on silence, 1610  
 on splitting, 1646  
 on splitting of the object, 1642  
 on squiggle game, 1650  
 structural theories and, 1666  
 on suffering, 1684  
 Suttie and, 1457  
 Swedish psychoanalysis and, 1699  
 on symbiosis, 1706  
 on symbolization, 1713, 1714  
 on transference depression, 1780  
 on transference hatred, 1782  
 on unthinkable anxiety, 90  
 on visual arts, 1842  
 on work of the negative, 1130  
 Zetzel-Rosenberg and, 1887–1888  
 Winnik, Heinz, 877  
 Winternitz-Freud, Pauline Regine, **635**  
 Winternitz-Freud, Rosi, 635  
 Winterstein, Alfred Freiherr von, 133, 163, 732, 1858, **1863–1864**  
 Wirth, Louis, 1632  
 Wise, Ursula. *See* Isaacs-Sutherland, Susan  
 Wisel, Adam, 1292  
 Wish for a baby, 252, 253, 571, **1864**  
 Wish-fulfillment, **1864–1865**  
 action-presentations and, 12  
 day's residues and, 367  
 dreams and, 436–437, 438, 442, 1083  
 fantasy and, 550, 551  
 flight into illness and, 590  
 hypocritical dreams and, 771–772  
 illusion and, 796  
 “Irma’s injection” dream and, 873  
 nightmares and, 1149  
 psychic reality and, 1357  
 punishment dreams and, 1422  
 rituals and, 1504  
*See also* Desire; Hallucinatory wish-fulfillment  
 Wish to be an analyst, 77, 122  
 Wishes, **1867–1868**  
*Wissenschaft*, 1550  
*Wisstrieb*. *See* Knowledge instinct  
 Wit. *See* Humor; Jokes  
 Witch metapsychology, **1868**  
 Wittels, Fritz, **1868–1869**  
 on applied psychoanalysis, 108  
 on death instinct, 372  
*Fackel, Die* and, 543, 924  
 Freud biography by, 642, 1869  
 photograph of, III:pl.17  
 prehistory and, 1303  
 Schilder and, 1538  
 Urbantschitsch and, 1828, 1869  
 Wiener psychoanalytische Vereinigung and, 1858  
 Wittgenstein, Ludwig  
 action-language and, 12  
 on epistemology, 1370  
 grid and, 704  
 on hermeneutics, 738  
 philosophy and, 1271  
 on psychic causality, 1354  
 Wittkower, Eric, 242, 1728, **1869–1870**  
*Witze*, 673, 682, 762  
 Wolf, Alexander, 601  
 Wolf, Ernest, 279  
 Wolf, Werner, 1765  
*Wolf Man, 60 Years Later, The* (Obholzer), 665  
*Wolf-Man by the Wolf-Man, The* (Gardiner), 665  
 “Wolf Man” case, **649–650**, 1221  
 activity/passivity and, 17  
 aggression and, 34  
 anxiety dreams and, 102, 103  
 Brunswick and, 233, 649, 1221  
 castration complex and, 252, 253, 650  
 constructions and, 336  
 Darwinism and, 366  
 deferred action and, 378, 380  
 déjà vu and, 381, 382  
 depersonalization and, 393  
 developmental disorders and, 408  
 developmental processes and, 1329  
 disavowal and, 415, 416, 1121  
 dream’s navel and, 443  
 fantasy and, 551, 552, 553  
 feces and, 564  
 Freud-Jung split and, 639  
 Gardiner and, 665  
 gifts and, 683  
 Hirschfeld, Elfriede and, 747  
 identification and, 787  
 infantile neurosis and, 821  
 infantile sexual curiosity and, 829  
 inferiority feelings and, 831  
 latent dream thoughts and, 948  
 letter and, 961  
 masturbation and, 1026  
 memories and, 1041  
 multilingualism and, 1086  
 narcissism and, 1105–1106  
 negative hallucination and, 1125  
 neuroses and, 1139  
 Oedipus complex and, 1184  
 payment for treatment and, 1069  
 phobias and, 1274  
 pleasure in thinking and, 1289  
 primal fantasies and, 1307  
 primal scene and, 336, 639, 650, 821, 829, 1310, 1565–1566  
 psychology and psychoanalysis and, 1397  
 psychoses and, 1404  
 Real and, 1453  
 repetitive dreams and, 1476  
 repudiation and, 1487  
 reversal into the opposite and, 1494  
 rumination and, 918  
 sadism and, 1525  
 symptom-formation and, 1717  
 termination of treatment and, 76, 650, 979, 1738  
 thought and, 1747  
 unconscious concepts and, 1817  
 Wiener Cottage Sanatorium and, 1828  
*Wolf Man’s Last Years, The* (Gardiner), 665  
*Wolf Man’s Magic Word, The* (Abraham), 7  
 Wolf-Somerset, Alessandra. *See* Tomasi di Palma di Lampedusa-Wolff Somerset, Alessandra  
 Wolfe, Theodore, 1462  
 Wolfenstein, Martha, **1870–1871**  
 Wolff, Antonia Anna, **1871–1872**  
 Wolff, Christian, 448, 1070, 1349  
 Wolffheim, Nelly, 1886  
 Wolowicz, Leopold, 1292  
 Women  
 civilization and, 299

## INDEX

Volume 1, pp. 1–662; Volume 2, pp. 663–1344; Volume 3, pp. 1345–1892

- Deutsch-Rosenbach on, 405  
 jouissance and, 895  
 phobias and, 306  
*See also* Female sexuality; Femininity;  
 Feminist views of psychoanalysis; Mother
- Woolf, Leonard, 695, 698, 753–754  
 Woolf, Virginia, 698, 753  
 Word association, 319, **1872–1873**  
 Word-presentations, 106, 1318, 1840, **1873–1875**  
 fundamental rule and, 656  
 thing-presentations and, 1742, 1874  
 Work, **1875–1877**  
 Work (W) group, 151, 710–711  
 Work of the negative, **1129–1130**, 1560, 1822, 1876  
 Working-off mechanisms, **1877**  
 Working over, **1877–1879**  
 Working-through, 1385, **1879–1880**  
 conscious processes and, 333  
 counter-transference and, 350  
 frame of psychoanalytic treatment and, 607  
 humor and, 763  
 memories and, 1041  
 memory and, 1043  
 negation and, 1123  
 resistance and, 1489, 1879, 1880  
 World Association of Psychoanalysis, 217, 455, 539  
 World Health Organization (WHO), 129, 828, 1138, 1276  
 World War I. *See* First World War  
 World War II. *See* Second World War  
*Wörter und ihre Schicksale* (Storfer), 1662  
 Wotan (Jung), 902  
*Wretched of the Earth, The* (Fanon), 550  
 Wride, Fanny, 131  
*Written on the Wind* (film), 294  
 Wulff, Mosche, **1881**  
 German psychoanalysis and, 674  
 Israeli psychoanalysis and, 876, 877  
*Psychotherapia* and, 1411  
 Russian/Soviet psychoanalysis and, 1518, 1519, 1881  
 Tegel clinic and, 1734, 1881  
 Wundt, Wilhelm M., 85, 319, 720  
*Wunsch*, 1677
- Y**
- Yalom, Irving, 1445  
 Yamamura, Michio, 887  
 Yanitskaia, Elisaveta, 1543  
 Yayhaoui, Abdesselam, 1156  
 Yearning. *See* Wishes  
 Yeltsin, Boris, 1520  
 Yerushalmi, Yosef Hayim, 900  
 Yonqin, 285  
 Yorke, Clifford, 1382  
*Young Abe Lincoln* (film), 292  
*Young Children in Wartime* (Freud and Burlingham-Tiffany), 619  
*Young Girl's Diary, A* (Hug-Hellmuth), 761–762, **1883**  
*Young Man Luther* (Erikson), 511, 1393  
 Yuan, Teresa, 287  
 Yugoslavian psychoanalysis. *See* Former Yugoslavian psychoanalysis
- Z**
- Zac, Joel, 118, 566  
 Zalkind, Aron, 403  
 Zaltzman, Nathalie, 327  
 Zamora, Carolina, 1637  
 Zapparoli, Giovanni Carlo, 880  
 Zappert, Julius, 843  
 Zavitzianos, Georges, 242, 245, 700, 701, **1885–1886**  
 Zeilinger, G. F., 135  
*Zeitschrift für Analytische Psychologie*, 80  
*Zeitschrift für Individualpsychologie*, 25  
*Zeitschrift für psychoanalytische Pädagogik*, 568, 861, 1044, 1544, **1886**, 1888–1889  
*Zeitschrift für psychoanalytische Theorie und Praxis*, 679  
*Zelig* (film), 47  
 Zeligs, Meyer A., 1610  
*Zentralblatt für Psychoanalyse*, **1887**  
 Abraham and, 5  
 on Chilean psychoanalysis, 284  
 International Psychoanalytical Association and, 854  
*Internationale Zeitschrift für Psychoanalyse* and, 860  
 Marcinowski and, 1011  
 Stekel and, 25, 884, 1657, 1887  
*Zentralblatt für Psychotherapie*, 49  
 Zentralinstitut für psychogene Erkrankungen, 164–165, 1547  
*Zeremoniell*. *See* Rituals  
 Zetzel-Rosenberg, Elizabeth, **1887–1888**  
 on analyzability, 81  
 on anxiety neurosis, 1137  
 International Psychoanalytical Association and, 857  
 on therapeutic alliance, 1741, 1789, 1888  
 Zeus, 348  
 Zilboorg, Gregory, 1377  
 Zimmermann, David, 216, 566, 1833  
 Zionism, 460  
 Žižek, Slavoj, 987  
 Zulliger, Hans, **1888–1889**  
 Pfister and, 1260, 1888  
 Schneider and, 1544  
 Swiss psychoanalysis and, 1550, 1702, 1703  
*Zeitschrift für psychoanalytische Pädagogik* and, 1886  
*Zum Kampf um die Psychoanalyse* (Pfister), 1260  
*Zum Typus Weib* (Andreas-Salomé), 84  
 “Zur Frage der Sexualaufklärung” (Annie Reich), 1461  
*Zur Menschenkenntnis: Ein psypsychoanalytischer Wegweiser für den Umgang mit sich selbst und anderen* (Sachs), 1523  
*Zur Psychopathologie der Revolution: die Vaterlose Gesellschaft* (Federn), 568  
*Zur Psychopathologie des Alltagslebens. The Psychopathology of Everyday Life, The* “Zur Sonderstellung des Vatermordes” (Storfer), 1661  
 “Zur Überwindung der kulturellen Krise” (Gross), 708  
 Zürich School, 79, 1282  
*See also* Jung, Carl Gustav  
*Zwang*. *See* Compulsion  
*Zwangneurose*. *See* Obsessional neurosis  
 Zweig, Arnold, **1889–1890**  
 Freud, Ernst and, 622  
 Freud, Oliver and, 631–632  
*Psychoanalytische Bewegung, Die* and, 1387  
 surrealism and, 1695  
 Zweig, Stefan, **1890–1891**  
*Almanach der Psychoanalyse* and, 50  
 Argentinian psychoanalysis and, 116  
 death of, 726  
 Freud on, 432  
 Goethe Prize and, 687  
 Happel and, 726  
*Psychoanalytische Bewegung, Die* and, 1387  
 Reverchon-Jouve and, 1493  
 surrealism and, 1696  
 Zygouris, Radmila, 1552